



**DFS PORTION of FCC 47 CFR PART 15 SUBPART E
DFS PORTION of INDUSTRY CANADA RSS-247 ISSUE 1**

CERTIFICATION TEST REPORT

FOR

802.11a/b/g/n/ac WIRELESS ROUTER

MODEL NUMBER: MX65W-HW

FCC ID: UDX-60047015

IC: 6961A-60047015

REPORT NUMBER: 15U22276-E2V1

ISSUE DATE: FEBRUARY 19, 2016

Prepared for
**CISCO SYSTEMS, INC.
170 WEST TASMAN DRIVE
SAN JOSE, CA, 95134, USA**

Prepared by
**UL VERIFICATION SERVICES INC.
47173 BENICIA STREET
FREMONT, CA 94538, U.S.A.
TEL: (510) 771-1000
FAX: (510) 661-0888**



NVLAP LAB CODE 200065-0

Revision History

<u>Rev.</u>	<u>Issue Date</u>	<u>Revisions</u>	<u>Revised By</u>
V1	02/19/16	Initial Issue	C. Cheung

TABLE OF CONTENTS

1. ATTESTATION OF TEST RESULTS	4
2. TEST METHODOLOGY	5
3. FACILITIES AND ACCREDITATION	5
4. CALIBRATION AND UNCERTAINTY	5
4.1. <i>MEASURING INSTRUMENT CALIBRATION</i>	<i>5</i>
4.2. <i>SAMPLE CALCULATION</i>	<i>5</i>
4.3. <i>MEASUREMENT UNCERTAINTY</i>	<i>5</i>
5. DYNAMIC FREQUENCY SELECTION.....	6
5.1. <i>OVERVIEW</i>	<i>6</i>
5.1.1. <i>LIMITS</i>	<i>6</i>
5.1.2. <i>TEST AND MEASUREMENT SYSTEM</i>	<i>10</i>
5.1.3. <i>SETUP OF EUT</i>	<i>13</i>
5.1.4. <i>DESCRIPTION OF EUT</i>	<i>14</i>
5.2. <i>RESULTS FOR 20 MHz BANDWIDTH</i>	<i>16</i>
5.2.1. <i>TEST CHANNEL</i>	<i>16</i>
5.2.2. <i>RADAR WAVEFORMS AND TRAFFIC.....</i>	<i>16</i>
5.2.3. <i>CHANNEL AVAILABILITY CHECK TIME.....</i>	<i>25</i>
5.2.4. <i>OVERLAPPING CHANNEL TESTS.....</i>	<i>30</i>
5.2.5. <i>MOVE AND CLOSING TIME</i>	<i>30</i>
5.2.6. <i>DETECTION BANDWIDTH.....</i>	<i>35</i>
5.2.7. <i>IN-SERVICE MONITORING</i>	<i>37</i>
5.3. <i>RESULTS FOR 40 MHz BANDWIDTH</i>	<i>44</i>
5.3.1. <i>TEST CHANNEL</i>	<i>44</i>
5.3.2. <i>RADAR WAVEFORMS AND TRAFFIC.....</i>	<i>44</i>
5.3.3. <i>CHANNEL AVAILABILITY CHECK TIME.....</i>	<i>53</i>
5.3.1. <i>OVERLAPPING CHANNEL TESTS.....</i>	<i>58</i>
5.3.2. <i>MOVE AND CLOSING TIME</i>	<i>58</i>
5.3.1. <i>NON-OCCUPANCY PERIOD</i>	<i>63</i>
5.3.2. <i>DETECTION BANDWIDTH.....</i>	<i>64</i>
5.3.3. <i>IN-SERVICE MONITORING</i>	<i>66</i>
5.4. <i>RESULTS FOR 80 MHz BANDWIDTH</i>	<i>73</i>
5.4.1. <i>TEST CHANNEL</i>	<i>73</i>
5.4.2. <i>RADAR WAVEFORMS AND TRAFFIC.....</i>	<i>73</i>
5.4.1. <i>CHANNEL AVAILABILITY CHECK TIME.....</i>	<i>82</i>
5.4.2. <i>OVERLAPPING CHANNEL TESTS.....</i>	<i>87</i>
5.4.3. <i>MOVE AND CLOSING TIME</i>	<i>87</i>
5.4.1. <i>NON-OCCUPANCY PERIOD</i>	<i>92</i>
5.4.2. <i>DETECTION BANDWIDTH.....</i>	<i>93</i>
5.4.3. <i>IN-SERVICE MONITORING</i>	<i>95</i>
6. BRIDGE MODE RESULTS.....	103
7. SETUP PHOTOS.....	104

1. ATTESTATION OF TEST RESULTS

COMPANY NAME: CISCO SYSTEMS, INC.
170 WEST TASMAN DRIVE
SAN JOSE, CA, 95134, USA

EUT DESCRIPTION: 802.11 a/b/g/n/ac WIRELESS ROUTER

MODEL: MX65W-HW

SERIAL NUMBER: Q2RN-YUYC-DNJE

DATE TESTED: FEBRUARY 3, 2016 & FEBRUARY 8, 2016

APPLICABLE STANDARDS	
STANDARD	TEST RESULTS
DFS Portion of CFR 47 Part 15 Subpart E	Pass
INDUSTRY CANADA RSS-247 Issue 1	Pass

UL Verification Services Inc. tested the above equipment in accordance with the requirements set forth in the above standards. All indications of Pass/Fail in this report are opinions expressed by UL Verification Services Inc. based on interpretations and/or observations of test results. Measurement Uncertainties were not taken into account and are published for informational purposes only. The test results show that the equipment tested is capable of demonstrating compliance with the requirements as documented in this report.

Note: The results documented in this report apply only to the tested sample, under the conditions and modes of operation as described herein. This document may not be altered or revised in any way unless done so by UL Verification Services Inc. and all revisions are duly noted in the revisions section. Any alteration of this document not carried out by UL Verification Services Inc. will constitute fraud and shall nullify the document. This report must not be used by the client to claim product certification, approval, or endorsement by NVLAP, NIST, any agency of the Federal Government, or any agency of any government.

Approved & Released For
UL Verification Services Inc. By:

Tested By:



CONAN CHEUNG
PROJECT LEAD
UL Verification Services Inc.

HENRY LAU
EMC ENGINEER
UL Verification Services Inc.

2. TEST METHODOLOGY

The tests documented in this report were performed in accordance with the DFS portion of FCC CFR 47 Part 2, FCC CFR 47 Part 15, FCC 06-96, FCC KDB 789033, KDB 905462 D02 and D03, ANSI C63.10-2013, RSS-247 Issue 1.

3. FACILITIES AND ACCREDITATION

The test sites and measurement facilities used to collect data are located at 47173 Benicia Street, Fremont, California, USA.

UL Verification Services, Inc. is accredited by NVLAP, Laboratory Code 200065-0. The full scope of accreditation can be viewed at <http://ts.nist.gov/standards/scopes/2000650.htm>.

4. CALIBRATION AND UNCERTAINTY

4.1. MEASURING INSTRUMENT CALIBRATION

The measuring equipment utilized to perform the tests documented in this report has been calibrated in accordance with the manufacturer's recommendations, and is traceable to recognized national standards.

4.2. SAMPLE CALCULATION

Where relevant, the following sample calculation is provided:

$$\begin{aligned} \text{Field Strength (dBuV/m)} &= \text{Measured Voltage (dBuV)} + \text{Antenna Factor (dB/m)} + \\ &\text{Cable Loss (dB)} - \text{Preamp Gain (dB)} \\ 36.5 \text{ dBuV} + 18.7 \text{ dB/m} + 0.6 \text{ dB} - 26.9 \text{ dB} &= 28.9 \text{ dBuV/m} \end{aligned}$$

4.3. MEASUREMENT UNCERTAINTY

Where relevant, the following measurement uncertainty levels have been estimated for tests performed on the apparatus:

PARAMETER	UNCERTAINTY
Conducted Disturbance, 0.15 to 30 MHz	± 3.52 dB
Radiated Disturbance, 30 to 1000 MHz	± 4.94 dB
Radiated Disturbance, 1 to 6 GHz	± 3.86 dB
Radiated Disturbance, 6 to 18 GHz	± 4.23 dB
Radiated Disturbance, 18 to 26 GHz	± 5.30 dB
Radiated Disturbance, 26 to 40 GHz	± 5.23 dB

Uncertainty figures are valid to a confidence level of 95%.

5. DYNAMIC FREQUENCY SELECTION

5.1. OVERVIEW

5.1.1. LIMITS

INDUSTRY CANADA

IC RSS-247 is closely harmonized with FCC Part 15 DFS rules. The deviations are as follows:

RSS-247 Issue 1

Note: For the band 5600–5650 MHz, no operation is permitted.

Until further notice, devices subject to this annex shall not be capable of transmitting in the band 5600–5650 MHz. This restriction is for the protection of Environment Canada weather radars operating in this band.

FCC

§15.407 (h), FCC KDB 905462 D02 “COMPLIANCE MEASUREMENT PROCEDURES FOR UNLICENSED-NATIONAL INFORMATION INFRASTRUCTURE DEVICES OPERATING IN THE 5250-5350 MHz AND 5470-5725 MHz BANDS INCORPORATING DYNAMIC FREQUENCY SELECTION” and KDB 905462 D03 “U-NII CLIENT DEVICES WITHOUT RADAR DETECTION CAPABILITY”.

Table 1: Applicability of DFS requirements prior to use of a channel

Requirement	Operational Mode		
	Master	Client (without radar detection)	Client (with radar detection)
Non-Occupancy Period	Yes	Not required	Yes
DFS Detection Threshold	Yes	Not required	Yes
Channel Availability Check Time	Yes	Not required	Not required
U-NII Detection Bandwidth	Yes	Not required	Yes

Table 2: Applicability of DFS requirements during normal operation

Requirement	Operational Mode		
	Master	Client (without DFS)	Client (with DFS)
DFS Detection Threshold	Yes	Not required	Yes
Channel Closing Transmission Time	Yes	Yes	Yes
Channel Move Time	Yes	Yes	Yes
U-NII Detection Bandwidth	Yes	Not required	Yes

Additional requirements for devices with multiple bandwidth modes	Master Device or Client with Radar DFS	Client (without DFS)
<i>U-NII Detection Bandwidth and Statistical Performance Check</i>	All BW modes must be tested	Not required
<i>Channel Move Time and Channel Closing Transmission Time</i>	Test using widest BW mode available	Test using the widest BW mode available for the link
<i>All other tests</i>	Any single BW mode	Not required
Note: Frequencies selected for statistical performance check (Section 7.8.4) should include several frequencies within the radar detection bandwidth and frequencies near the edge of the radar detection bandwidth. For 802.11 devices it is suggested to select frequencies in all 20 MHz channel blocks and a null frequency between the bonded 20 MHz channel blocks.		

Table 3: Interference Threshold values, Master or Client incorporating In-Service Monitoring

Maximum Transmit Power	Value (see notes)
E.I.R.P. \geq 200 mill watt	-64 dBm
E.I.R.P. < 200 mill watt and power spectral density < 10 dBm/MHz	-62 dBm
E.I.R.P. < 200 mill watt that do not meet power spectral density requirement	-64 dBm
<p>Note 1: This is the level at the input of the receiver assuming a 0 dBi receive antenna Note 2: Throughout these test procedures an additional 1 dB has been added to the amplitude of the test transmission waveforms to account for variations in measurement equipment. This will ensure that the test signal is at or above the detection threshold level to trigger a DFS response. Note 3: E.I.R.P. is based on the highest antenna gain. For MIMO devices refer to KDB publication 662911 D01.</p>	

Table 4: DFS Response requirement values

Parameter	Value
<i>Non-occupancy period</i>	30 minutes
<i>Channel Availability Check Time</i>	60 seconds
<i>Channel Move Time</i>	10 seconds (See Note 1)
<i>Channel Closing Transmission Time</i>	200 milliseconds + approx. 60 milliseconds over remaining 10 second period. (See Notes 1 and 2)
<i>U-NII Detection Bandwidth</i>	Minimum 100% of the U-NII 99% transmission power bandwidth. (See Note 3)
<p>Note 1: <i>Channel Move Time</i> and the <i>Channel Closing Transmission Time</i> should be performed with Radar Type 0. The measurement timing begins at the end of the Radar Type 0 burst. Note 2: The <i>Channel Closing Transmission Time</i> is comprised of 200 milliseconds starting at the beginning of the <i>Channel Move Time</i> plus any additional intermittent control signals required to facilitate a <i>Channel</i> move (an aggregate of 60 milliseconds) during the remainder of the 10 second period. The aggregate duration of control signals will not count quiet periods in between transmissions. Note 3: During the <i>U-NII Detection Bandwidth</i> detection test, radar type 0 should be used. For each frequency step the minimum percentage of detection is 90 percent. Measurements are performed with no data traffic.</p>	

Table 5 – Short Pulse Radar Test Waveforms

Radar Type	Pulse Width (usec)	PRI (usec)	Pulses	Minimum Percentage of Successful Detection	Minimum Trials
0	1	1428	18	See Note 1	See Note 1
1	1	Test A: 15 unique PRI values randomly selected from the list of 23 PRI values in table 5a	Roundup: $\{(1/360) \times (19 \times 10^6 \text{ PRI}_{\text{usec}})\}$	60%	30
		Test B: 15 unique PRI values randomly selected within the range of 518-3066 usec. With a minimum increment of 1 usec, excluding PRI values selected in Test A			
2	1-5	150-230	23-29	60%	30
3	6-10	200-500	16-18	60%	30
4	11-20	200-500	12-16	60%	30
Aggregate (Radar Types 1-4)				80%	120
Note 1: Short Pulse Radar Type 0 should be used for the <i>Detection Bandwidth</i> test, <i>Channel Move Time</i> , and <i>Channel Closing Time</i> tests.					

Table 6 – Long Pulse Radar Test Signal

Radar Waveform Type	Pulse Width (μsec)	Chirp Width (MHz)	PRI (μsec)	Pulses per Burst	Number of Bursts	Minimum Percentage of Successful Detection	Minimum Trials
5	50-100	5-20	1000-2000	1-3	8-20	80%	30

Table 7 – Frequency Hopping Radar Test Signal

Radar Waveform Type	Pulse Width (μsec)	PRI (μsec)	Pulses per Hop	Hopping Rate (kHz)	Hopping Sequence Length (msec)	Minimum Percentage of Successful Detection	Minimum Trials
6	1	333	9	0.333	300	70%	30

5.1.2. TEST AND MEASUREMENT SYSTEM

RADIATED METHOD SYSTEM BLOCK DIAGRAM

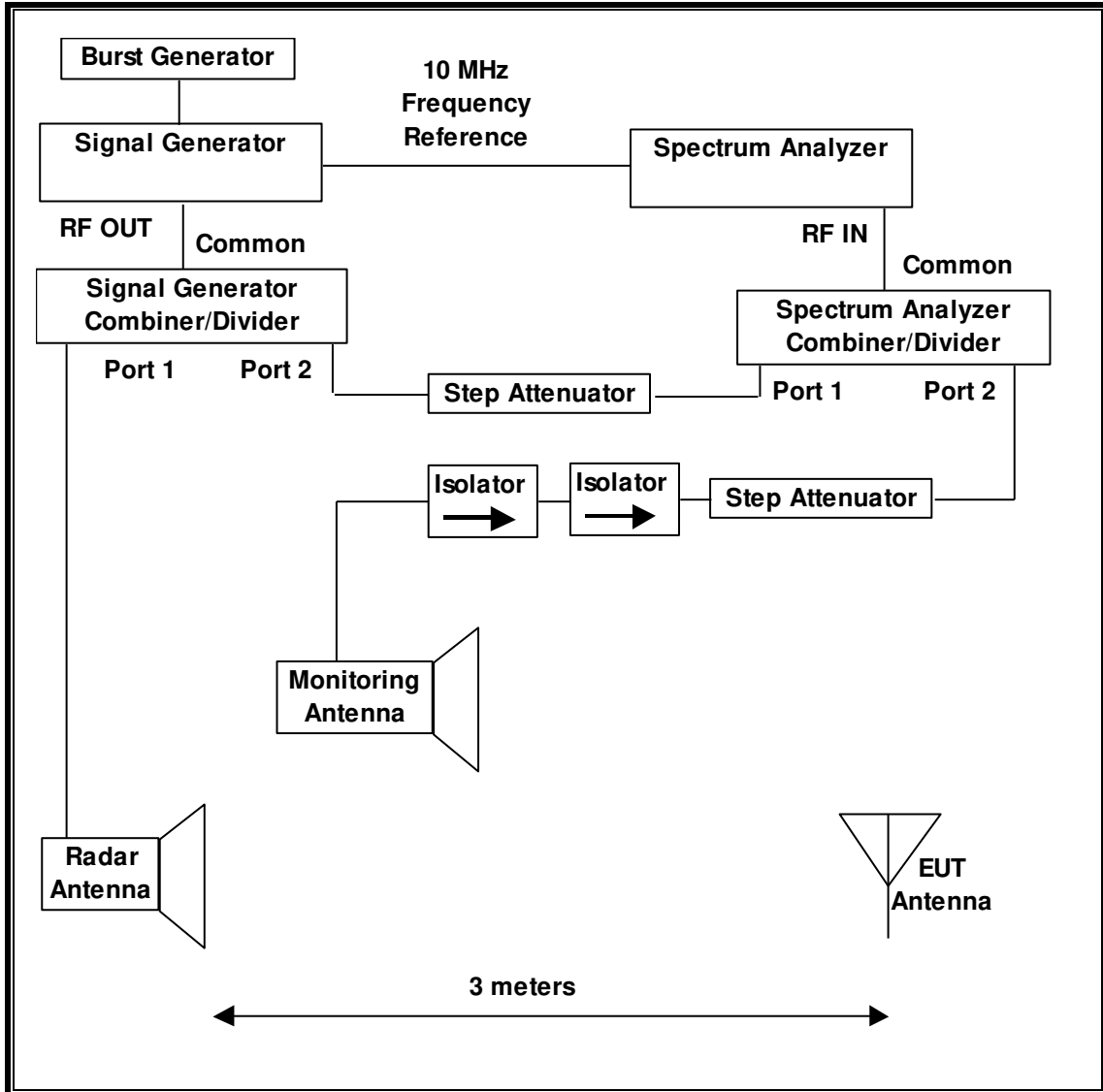

SYSTEM OVERVIEW

The short pulse and long pulse signal generating system utilizes the NTIA software. The Vector Signal Generator has been validated by the NTIA. The hopping signal generating system utilizes the CCS simulated hopping method and system, which has been validated by the DoD, FCC and NTIA. The software selects waveform parameters from within the bounds of the signal type on a random basis using uniform distribution.

The short pulse types 1, 2, 3 and 4, and the long pulse type 5 parameters are randomized at run-time.

The hopping type 6 pulse parameters are fixed while the hopping sequence is based on the August 2005 NTIA Hopping Frequency List. The initial starting point randomized at run-time and each subsequent starting point is incremented by 475. Each frequency in the 100-length segment is compared to the boundaries of the EUT Detection Bandwidth and the software creates a hopping burst pattern in accordance with Section 7.4.1.3 Method #2 Simulated Frequency Hopping Radar Waveform Generating Subsystem of KDB 905462 D02. The frequency of the signal generator is incremented in 1 MHz steps from F_L to F_H for each successive trial. This incremental sequence is repeated as required to generate a minimum of 30 total trials and to maintain a uniform frequency distribution over the entire Detection Bandwidth.

The signal monitoring equipment consists of a spectrum analyzer. The aggregate ON time is calculated by multiplying the number of bins above a threshold during a particular observation period by the dwell time per bin, with the analyzer set to peak detection and max hold.

SYSTEM CALIBRATION

A 50-ohm load is connected in place of the spectrum analyzer, and the spectrum analyzer is connected to a horn antenna via a coaxial cable, with the reference level offset set to (horn antenna gain – coaxial cable loss). The signal generator is set to CW mode. The amplitude of the signal generator is adjusted to yield a level of –64 dBm as measured on the spectrum analyzer.

Without changing any of the instrument settings, the spectrum analyzer is reconnected to the Common port of the Spectrum Analyzer Combiner/Divider. The Reference Level Offset of the spectrum analyzer is adjusted so that the displayed amplitude of the signal is –64 dBm.

The spectrum analyzer displays the level of the signal generator as received at the antenna ports of the Master Device. The interference detection threshold may be varied from the calibrated value of –64 dBm and the spectrum analyzer will still indicate the level as received by the Master Device.

ADJUSTMENT OF DISPLAYED TRAFFIC LEVEL

A link is established between the Master and Slave and the distance between the units is adjusted as needed to provide a suitable received level at the Master and Slave devices. The video test file is streamed to generate WLAN traffic. The monitoring antenna is adjusted so that the WLAN traffic level, as displayed on the spectrum analyzer, is at lower amplitude than the radar detection threshold.

TEST AND MEASUREMENT EQUIPMENT

The following test and measurement equipment was utilized for the DFS tests documented in this report:

TEST EQUIPMENT LIST				
Description	Manufacturer	Model	Serial Number	Cal Due
Spectrum Analyzer, PXA, 3Hz to 44GHz	Keysight	N9030A	US51350187	06/01/16
Signal Generator, MXG X-Series RF Vector	Agilent	N5172B	MY51350337	02/17/16
Arbitrary Waveform Generator	Agilent / HP	33220A	MY44037572	04/08/16

5.1.3. SETUP OF EUT

RADIATED METHOD EUT TEST SETUP

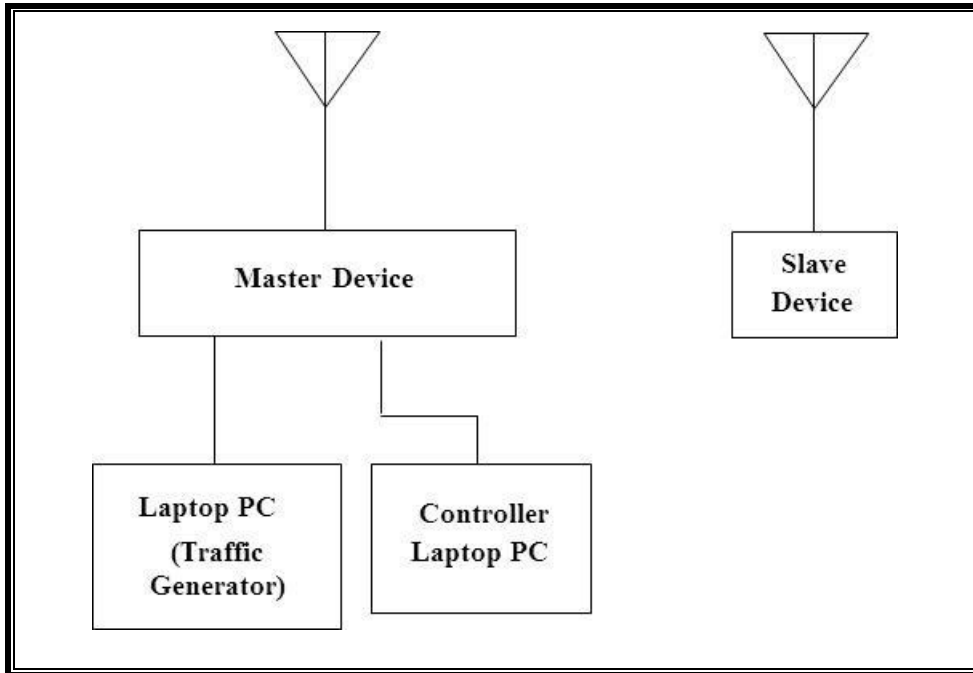

SUPPORT EQUIPMENT

The following support equipment was utilized for the DFS tests documented in this report:

PERIPHERAL SUPPORT EQUIPMENT LIST				
Description	Manufacturer	Model	Serial Number	FCC ID
AC Adapter (EUT)	Cisco	MA-PWR-90WAC	HSQD5AC003N	DoC
Laptop PC (Controller)	Lenovo	TYPE 3249-2HU	R9-AWVWD 11/01	DoC
AC Adapter (Controller)	Lenovo	ADLX65NLT2A	11S36200291ZZ300345B5 X	DoC
Laptop PC (Slave Device)	Apple	A1502	C02NT1VTG3QR	QDS-BRCM1069
AC Adapter (Slave Device)	Apple	A1435	D39433601B4FTC0A1	DoC
Laptop PC (Traffic Generator)	Lenovo	TYPE 4287-5TU	R9-PLM9D 12/06	QDS-BRCM1046
AC Adapter (Traffic Generator)	Lenovo	45N0121	11S45N0121Z1ZH XU213D MG	DoC

5.1.4. DESCRIPTION OF EUT

For FCC the EUT operates over the 5250-5350 MHz and 5470-5725 MHz ranges.

For IC the EUT operates over the 5250-5350 MHz and 5470-5725 MHz ranges, excluding the 5600-5650 MHz range.

The EUT is a Master Device.

The highest power level within these bands is 25.18 dBm EIRP in the 5250-5350 MHz band and 24.96 dBm EIRP in the 5470-5725 MHz band.

The highest gain antenna assembly utilized with the EUT has a gain of 3.3 dBi in the 5250-5350 MHz band and 3.3 dBi in the 5470-5725 MHz band. The lowest gain antenna assembly utilized with the EUT has a gain of 3.3 dBi in the 5250-5350 MHz band and 3.3 dBi in the 5470-5725 MHz band.

Two antennas are utilized to meet the diversity and MIMO operational requirements. The antenna 1 of the EUT has a gain of 3.3 dBi, and antenna 2 of the EUT has a gain of 3.3 dBi.

The rated output power of the Master unit is $> 23\text{dBm}$ (EIRP). Therefore the required interference threshold level is -64 dBm . After correction for procedural adjustments, the required radiated threshold at the antenna port is $-64 + 1 = -63\text{ dBm}$.

The calibrated radiated DFS Detection Threshold level is set to -64 dBm . The tested level is lower than the required level hence it provides a margin to the limit.

The EUT uses two transmitter/receiver chains, each connected to an antenna to perform radiated tests.

The Slave device associated with the EUT during these tests does not have radar detection capability.

WLAN traffic that meets or exceeds the minimum required loading was generated by transferring a data stream from the Master Device to the Slave Device using iPerf version 2.0.5 software package.

TPC is not required since the maximum EIRP is less than 500 mW (27 dBm), however TPC is implemented.

The EUT utilizes the 802.11ac architecture. Three nominal channel bandwidths are implemented: 20 MHz, 40 MHz and 80 MHz.

The software installed in the EUT is "firmware_wired_arm_nap_version wired-12-188894."

UNIFORM CHANNEL SPREADING

This function is not required per KDB 905462.

This is requirement not applicable to Slave Devices.

5.2. RESULTS FOR 20 MHz BANDWIDTH

5.2.1. TEST CHANNEL

All tests were performed at a channel center frequency of 5500 MHz.

5.2.2. RADAR WAVEFORMS AND TRAFFIC

RADAR WAVEFORMS

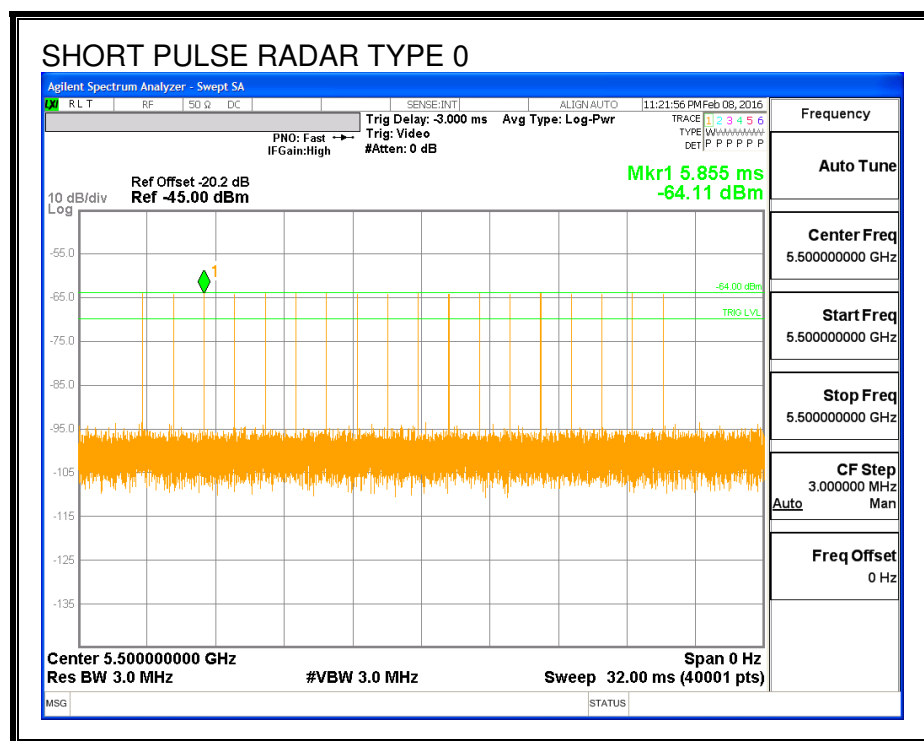

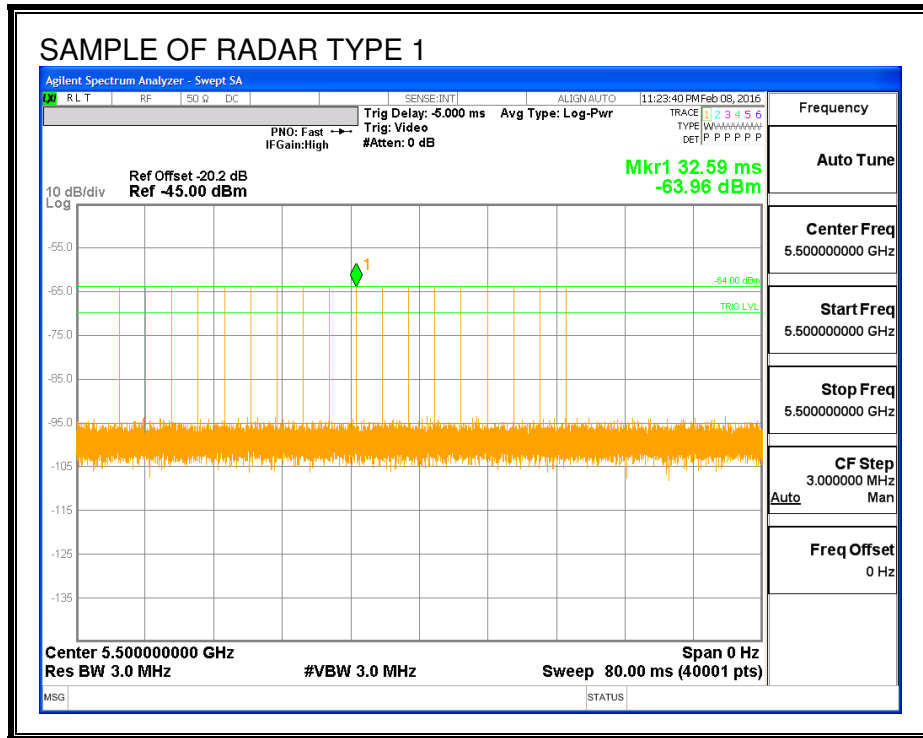

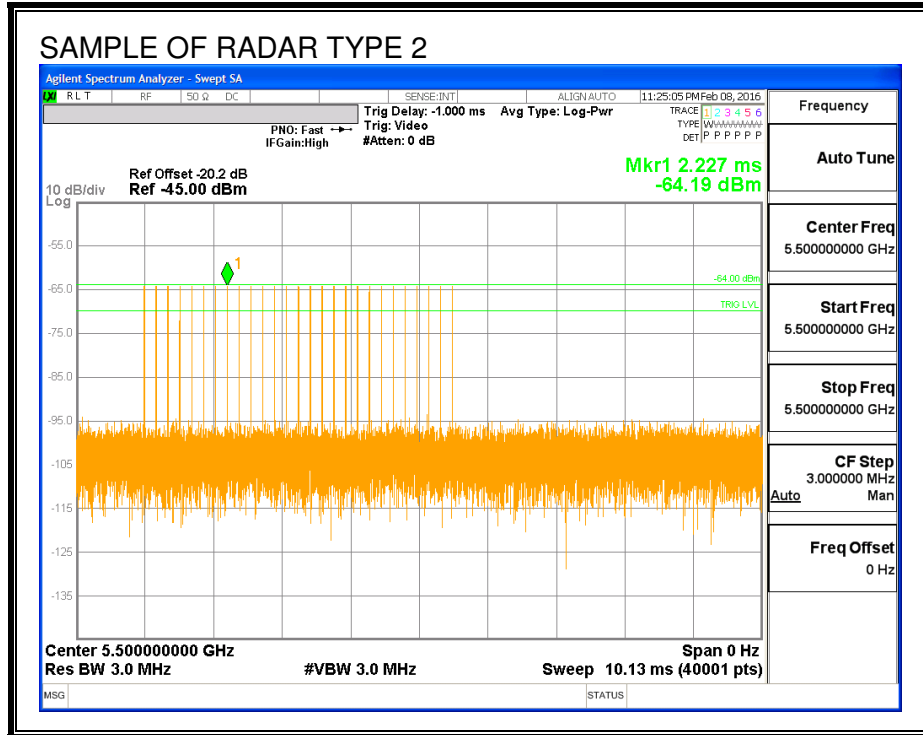

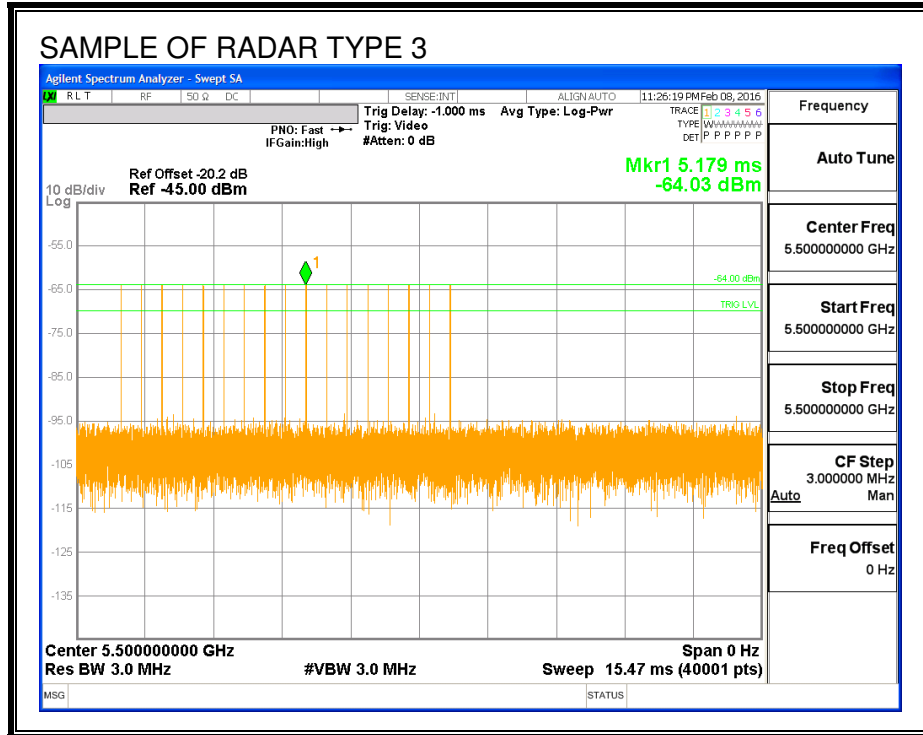

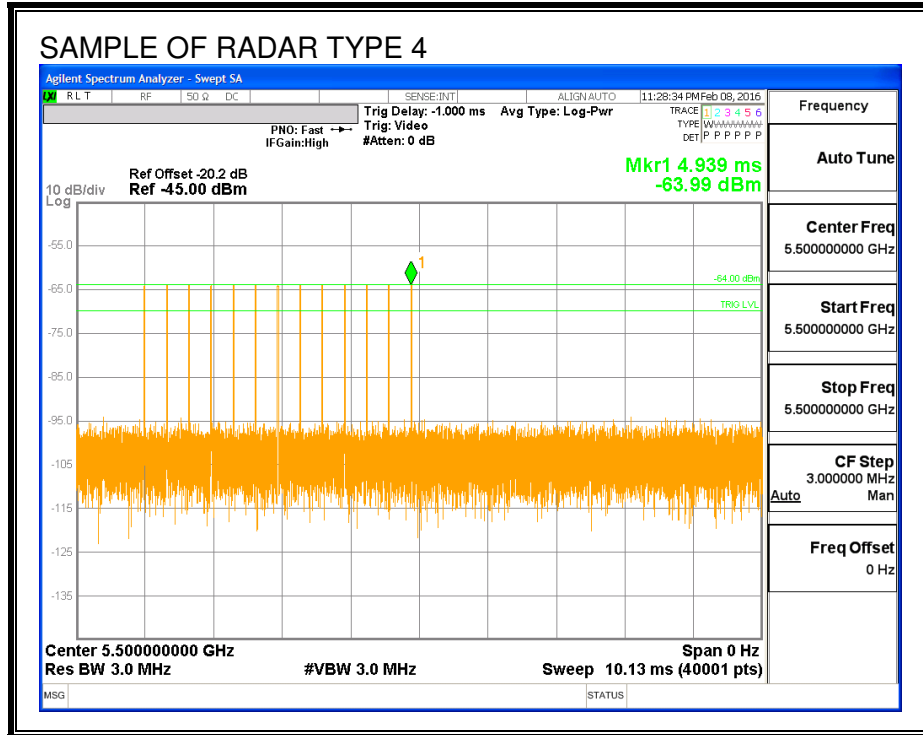

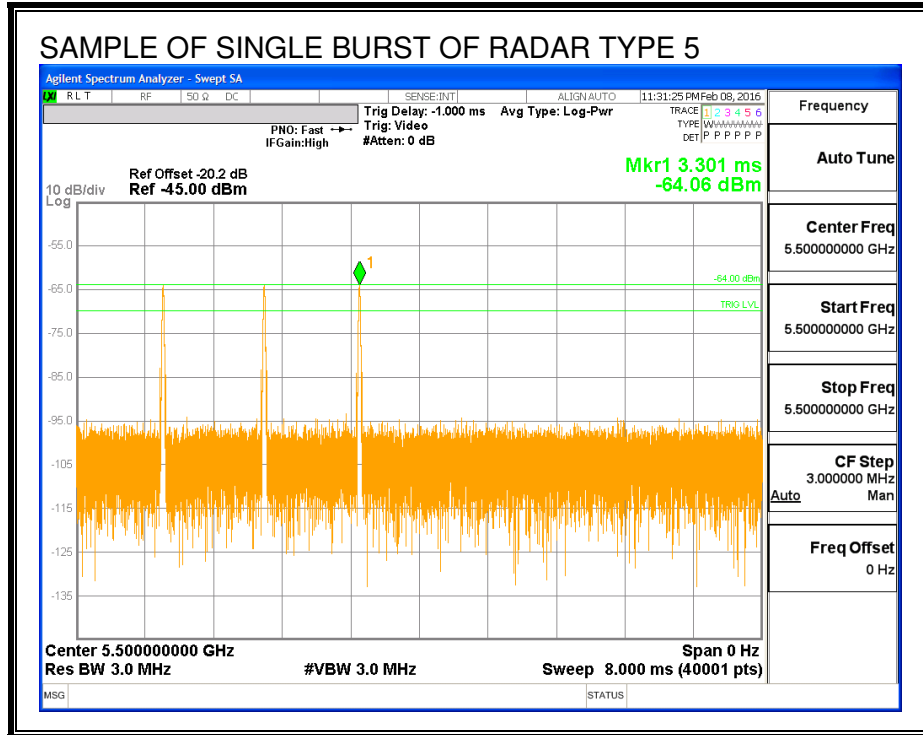

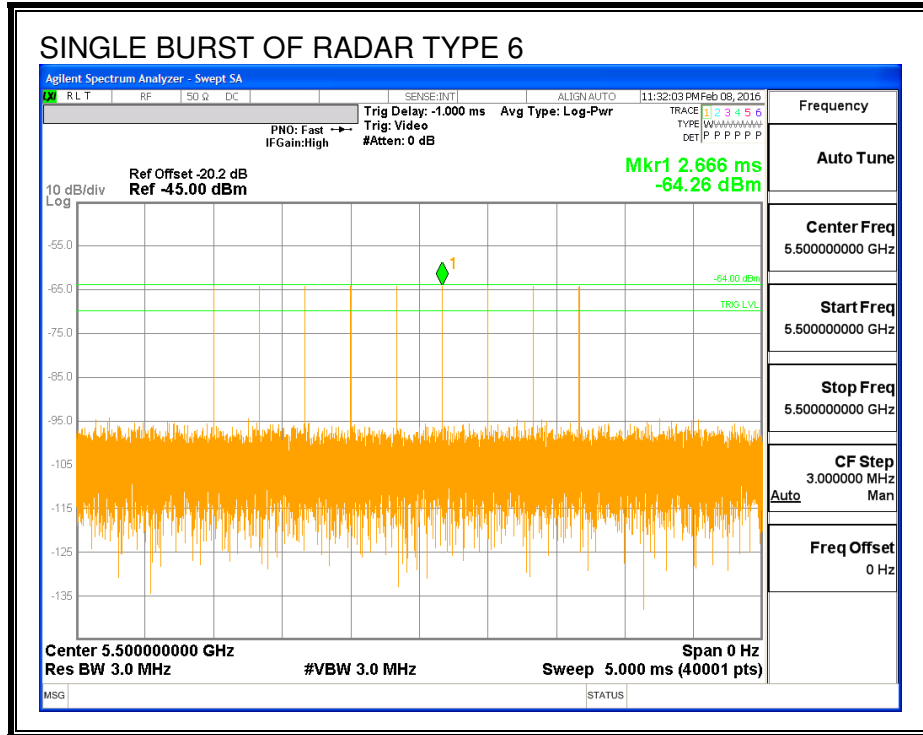

TRAFFIC

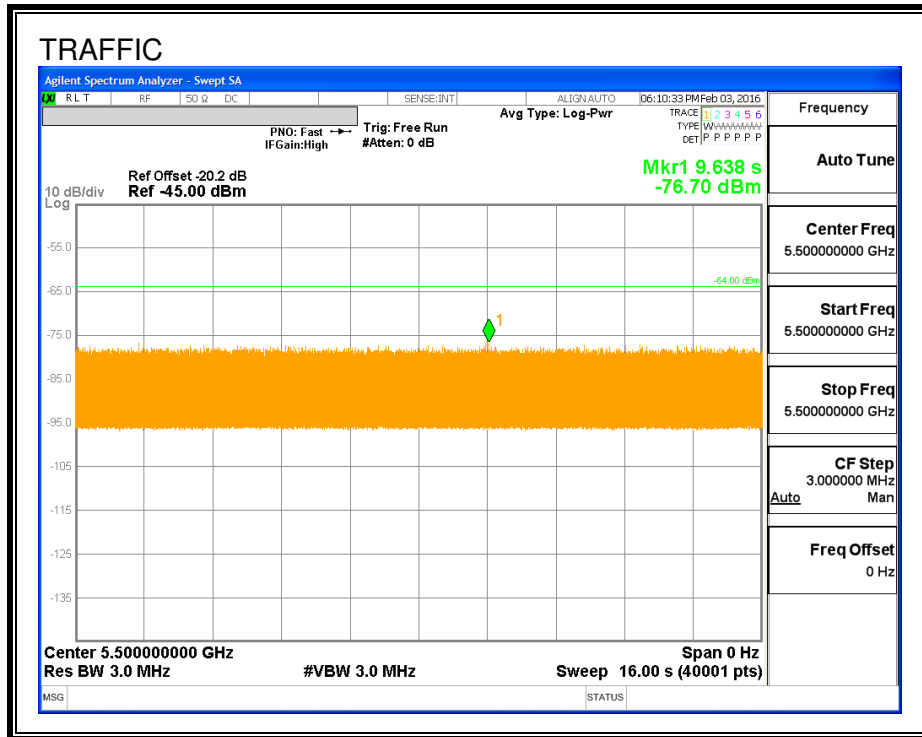

CHANNEL LOADING

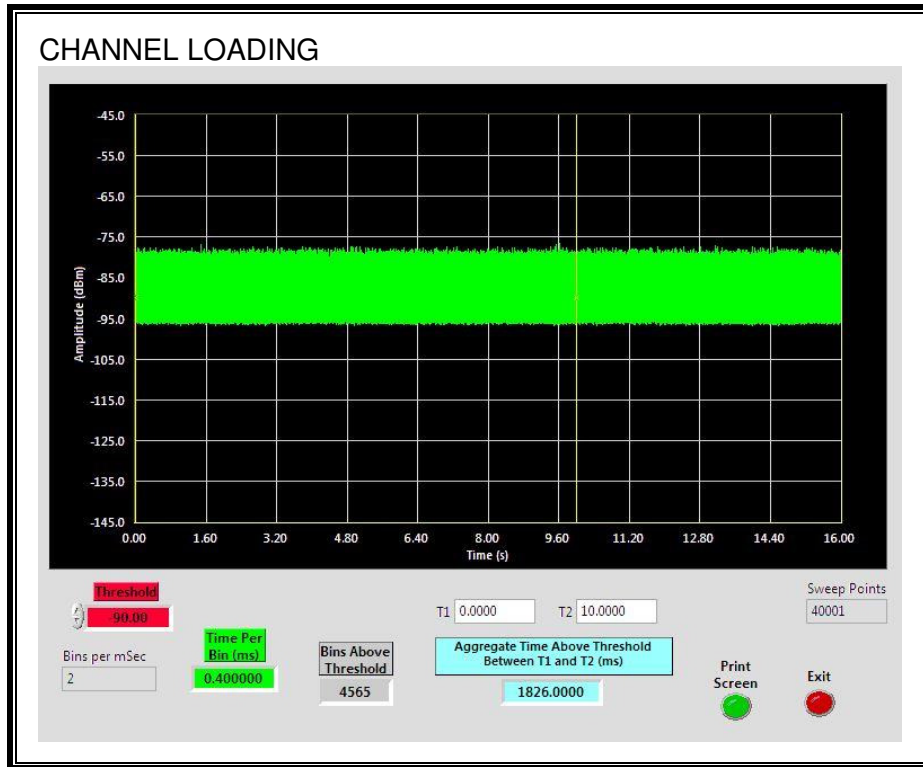

The level of traffic loading on the channel by the EUT is 18.26%

5.2.3. CHANNEL AVAILABILITY CHECK TIME

PROCEDURE TO DETERMINE INITIAL POWER-UP CYCLE TIME

A link was established on channel then the EUT was rebooted. The time from the cessation of traffic to the re-initialization of traffic was measured as the time required for the EUT to complete the total power-up cycle. The time to complete the initial power-up period is 60 seconds less than this total power-up time.

PROCEDURE FOR TIMING OF RADAR BURST

With a link established on channel, the EUT was rebooted. A radar signal was triggered within 0 to 6 seconds after the initial power-up period, and transmissions on the channel were monitored on the spectrum analyzer.

The Non-Occupancy list was cleared. With a link established on channel, the EUT was rebooted. A radar signal was triggered within 54 to 60 seconds after the initial power-up period, and transmissions on the channel were monitored on the spectrum analyzer.

QUANTITATIVE RESULTS

No Radar Triggered

Timing of Reboot (sec)	Timing of Start of Traffic (sec)	Total Power-up Cycle Time (sec)	Initial Power-up Cycle Time (sec)
30.35	160.0	129.7	69.7

Radar Near Beginning of CAC

Timing of Reboot (sec)	Timing of Radar Burst (sec)	Radar Relative to Reboot (sec)	Radar Relative to Start of CAC (sec)
29.95	100.7	70.8	1.1

Radar Near End of CAC

Timing of Reboot (sec)	Timing of Radar Burst (sec)	Radar Relative to Reboot (sec)	Radar Relative to Start of CAC (sec)
30.53	159.0	128.5	58.8

QUALITATIVE RESULTS

Timing of Radar Burst	Display on Control Computer	Spectrum Analyzer Display
No Radar Triggered	EUT marks Channel as active	Transmissions begin on channel after completion of the initial power-up cycle and the CAC
Within 0 to 6 second window	EUT indicates radar detected	No transmissions on channel
Within 54 to 60 second window	EUT indicates radar detected	No transmissions on channel

TIMING WITHOUT RADAR DURING CAC

AP is rebooted
 Traffic ceases
 Start of Initial Power-up cycle

End of Initial Power-up cycle
 Start of CAC

End of CAC
 Traffic is Initiated

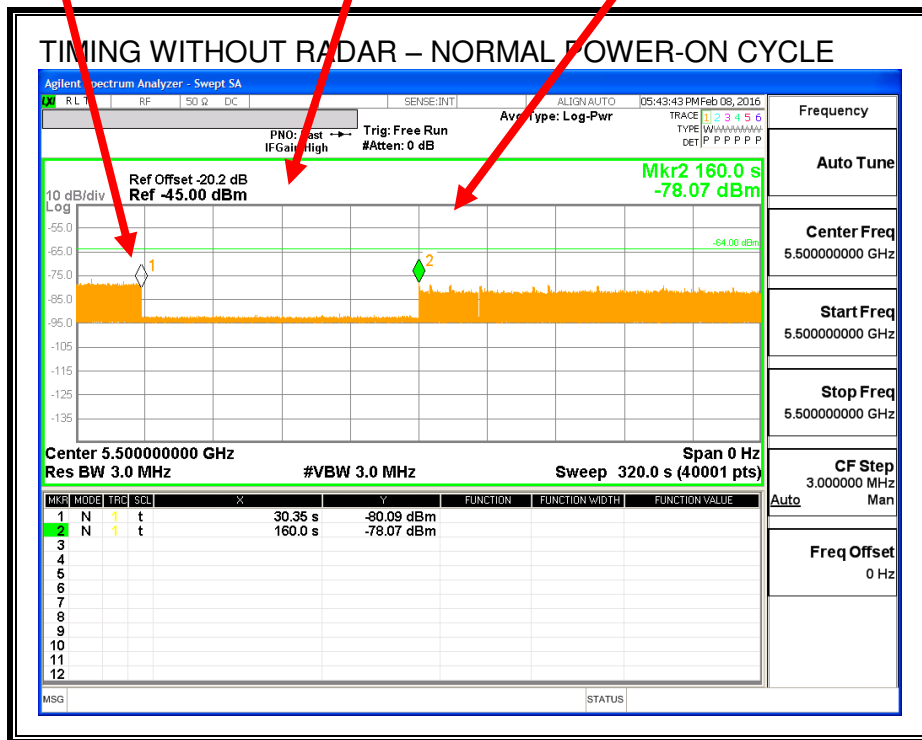

Transmissions begin on channel after completion of the initial power-up cycle and the CAC.

TIMING WITH RADAR NEAR BEGINNING OF CAC

AP is rebooted
 Traffic ceases
 Start of Initial Power-up cycle

End of Initial Power-up cycle
 Start of CAC

Radar Signal Applied

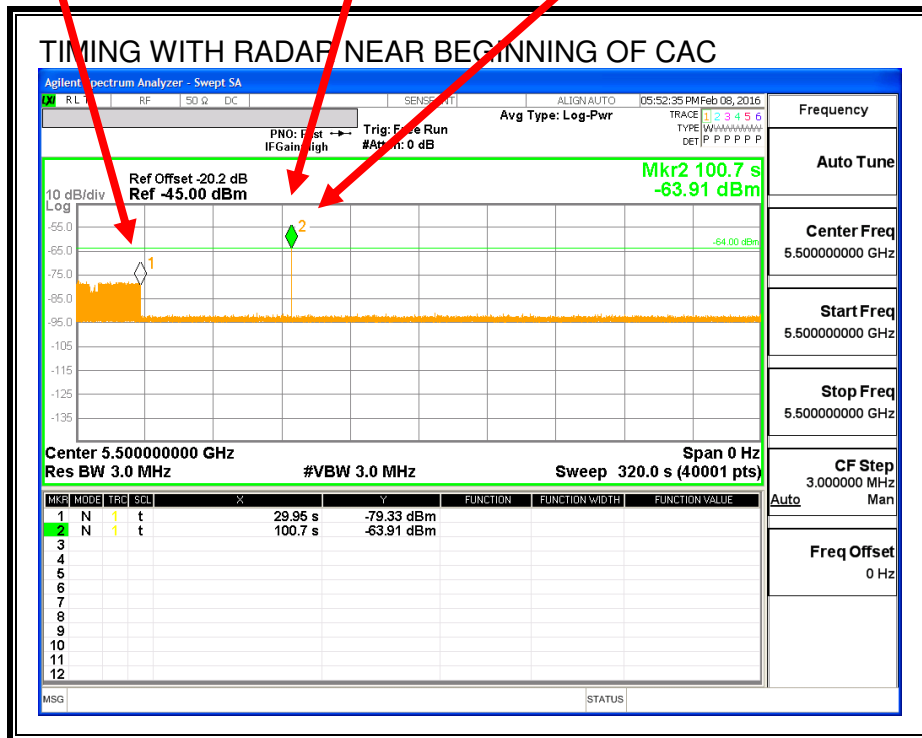

No EUT transmissions were observed after the radar signal.

TIMING WITH RADAR NEAR END OF CAC

AP is rebooted
 Traffic ceases
 Start of Initial Power-up cycle

End of Initial Power-up cycle
 Start of CAC

Radar Signal Applied

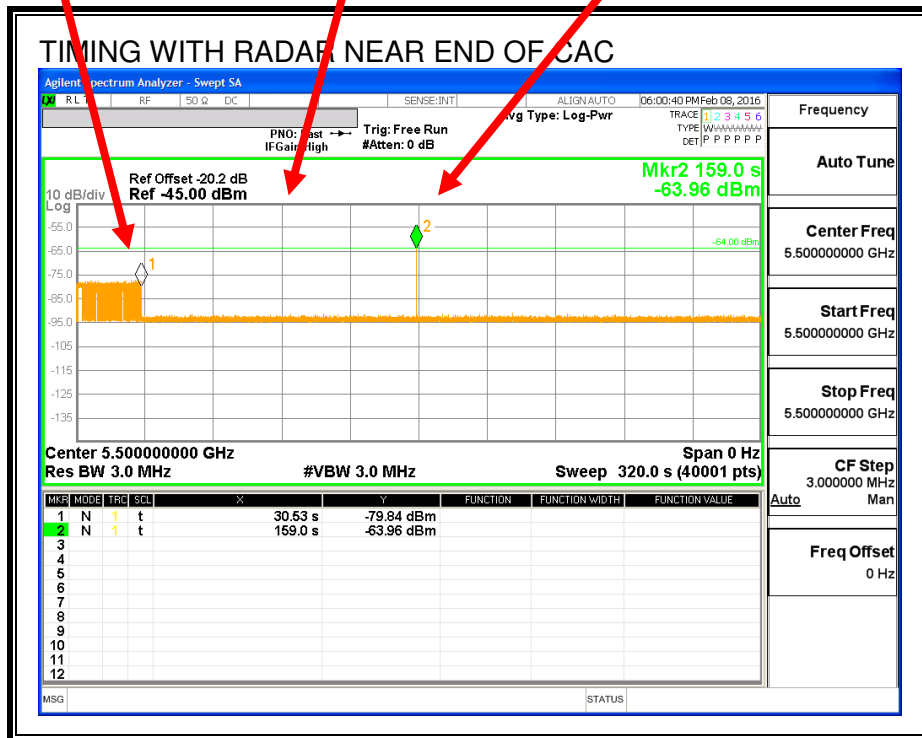

No EUT transmissions were observed after the radar signal.

5.2.4. OVERLAPPING CHANNEL TESTS

RESULTS

The channel spacing is not less than the channel bandwidth therefore the EUT does not have an overlapping channel plan.

These tests are not applicable.

5.2.5. MOVE AND CLOSING TIME

REPORTING NOTES

The reference marker is set at the end of last radar pulse.

The delta marker is set at the end of the last WLAN transmission following the radar pulse. This delta is the channel move time.

The aggregate channel closing transmission time is calculated as follows:

Aggregate Transmission Time =
(Number of analyzer bins showing transmission) * (dwell time per bin)

The observation period over which the aggregate time is calculated begins at (Reference Marker + 200 msec) and ends no earlier than (Reference Marker + 10 sec).

RESULTS

Channel Move Time (sec)	Limit (sec)
0.024	10

Aggregate Channel Closing Transmission Time (msec)	Limit (msec)
0.0	60

MOVE TIME

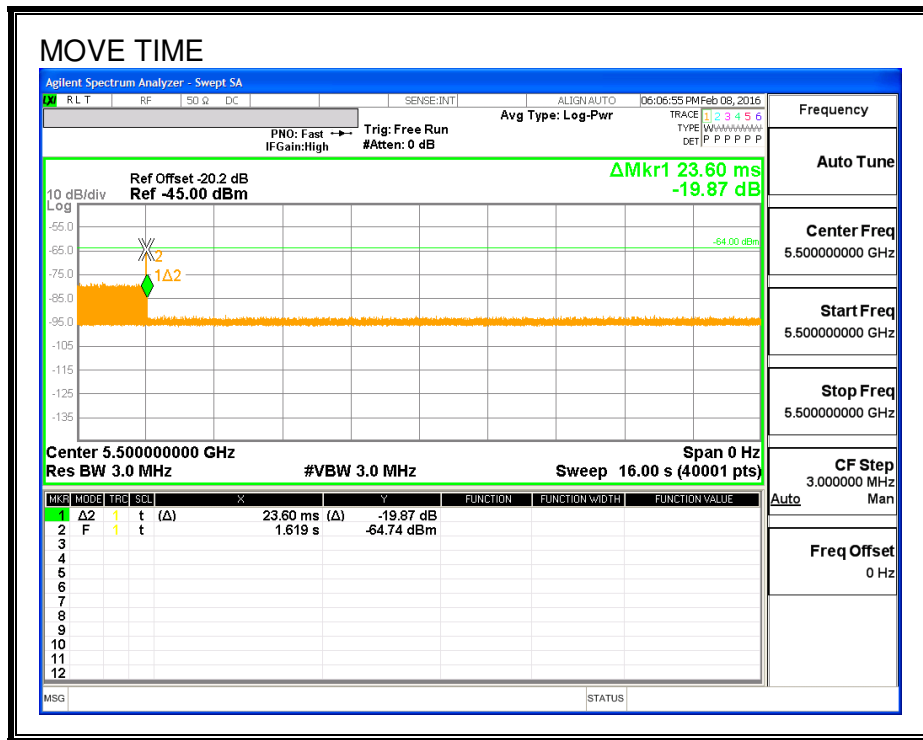

CHANNEL CLOSING TIME

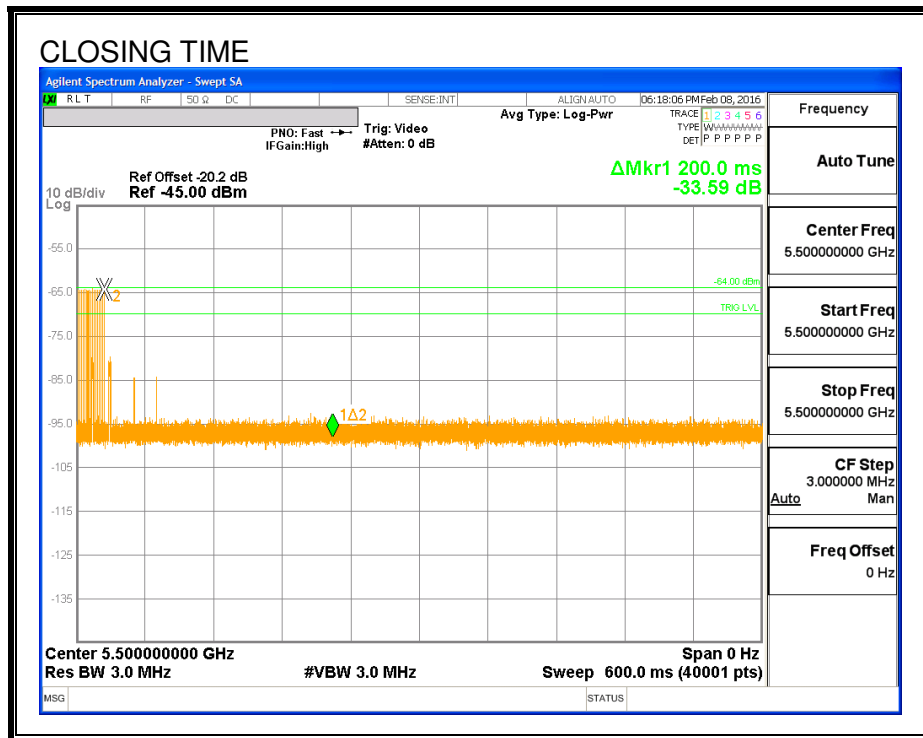

AGGREGATE CHANNEL CLOSING TRANSMISSION TIME

No transmissions are observed during the aggregate monitoring period.

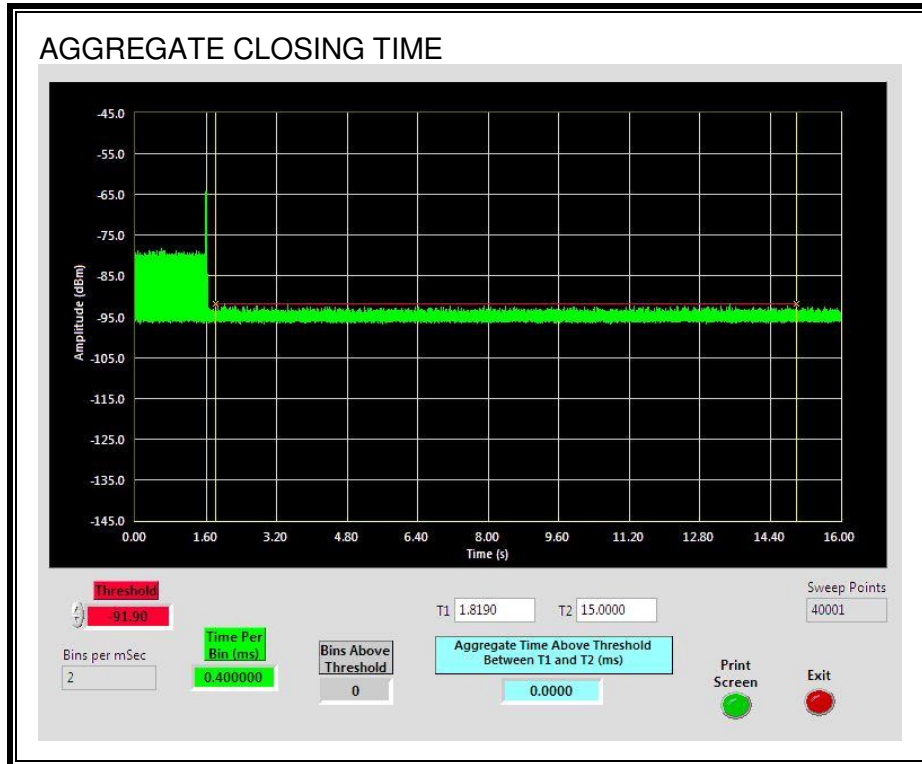

LONG PULSE CHANNEL MOVE TIME

The traffic ceases prior to 10 seconds after the end of the radar waveform.

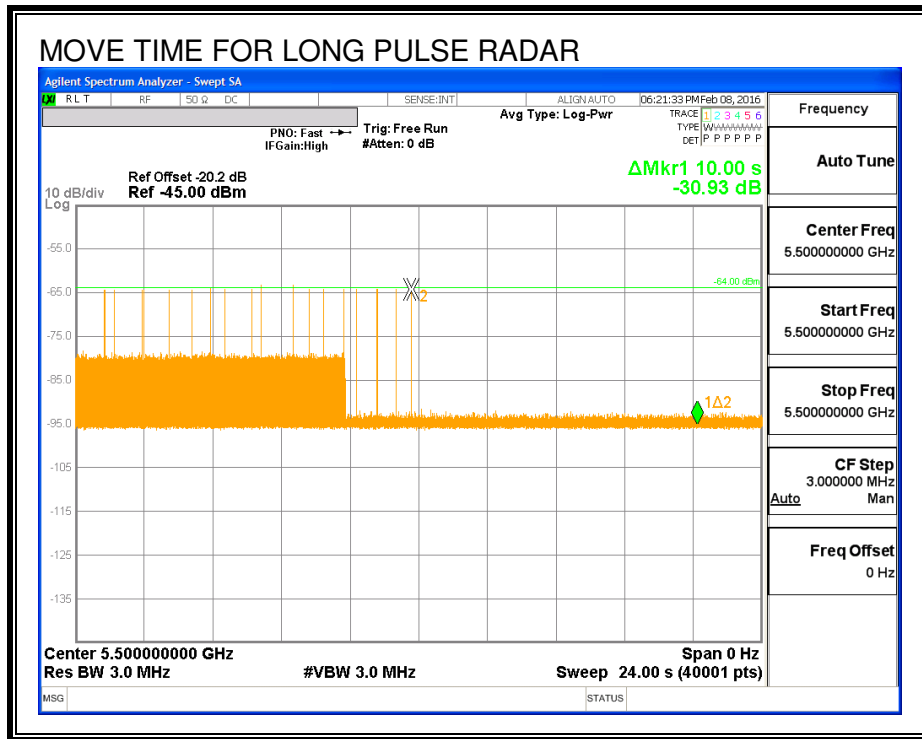

5.2.6. DETECTION BANDWIDTH

REFERENCE PLOT OF 99% POWER BANDWIDTH

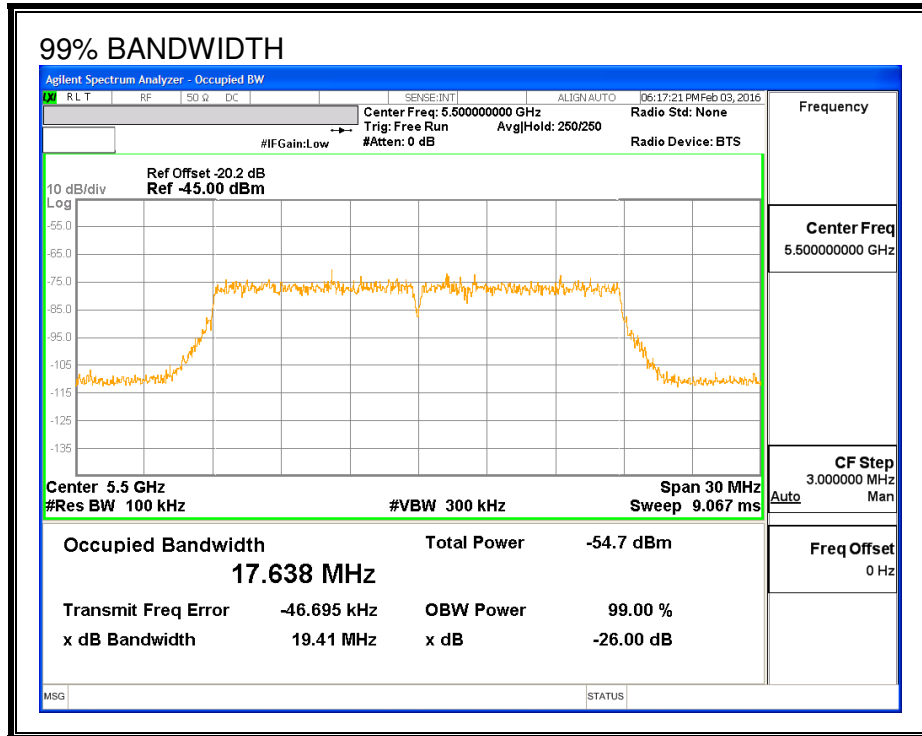

RESULTS

FL	FH	Detection Bandwidth	99% Power Bandwidth	Ratio of Detection BW to 99% Power BW	Minimum Limit
(MHz)	(MHz)	(MHz)	(MHz)	(%)	(%)
5491	5509	18	17.638	102.1	100

DETECTION BANDWIDTH PROBABILITY

DETECTION BANDWIDTH PROBABILITY RESULTS				
Detection Bandwidth Test Results				
FCC Type 0 Waveform: 1 us Pulse Width, 1428 us PRI, 18 Pulses per Burst				
Frequency (MHz)	Number of Trials	Number Detected	Detection (%)	Mark
5490	10	0	0	
5491	10	10	100	FL
5492	10	10	100	
5493	10	10	100	
5494	10	10	100	
5495	10	10	100	
5500	10	10	100	
5505	10	10	100	
5506	10	10	100	
5507	10	10	100	
5508	10	10	100	
5509	10	10	100	FH
5510	10	0	0	

5.2.7. IN-SERVICE MONITORING

RESULTS

FCC Radar Test Summary								
Signal Type	Number of Trials	Detection (%)	Limit (%)	Pass/Fail	Detection Bandwidth		80% of Det BW	
					FL	FH	FL5	FH5
FCC Short Pulse Type 1	30	100.00	60	Pass	5491	5509		
FCC Short Pulse Type 2	30	93.33	60	Pass	5491	5509		
FCC Short Pulse Type 3	30	86.67	60	Pass	5491	5509		
FCC Short Pulse Type 4	30	93.33	60	Pass	5491	5509		
Aggregate		93.33	80	Pass				
FCC Long Pulse Type 5	30	86.67	80	Pass	5491	5509	5493	5507
FCC Hopping Type 6	38	100.00	70	Pass	5491	5509		

TYPE 1 DETECTION PROBABILITY

Data Sheet for FCC Short Pulse Radar Type 1						
Waveform	Pulse Width (us)	PRI (us)	Pulses Per Burst	Test (A/B)	Frequency (MHz)	Successful Detection (Yes/No)
1001	1	3066	18	A	5500	Yes
1002	1	758	70	A	5500	Yes
1003	1	738	72	A	5500	Yes
1004	1	558	95	A	5500	Yes
1005	1	658	81	A	5500	Yes
1006	1	918	58	A	5500	Yes
1007	1	798	67	A	5500	Yes
1008	1	638	83	A	5500	Yes
1009	1	858	62	A	5500	Yes
1010	1	578	92	A	5500	Yes
1011	1	698	76	A	5500	Yes
1012	1	818	65	A	5500	Yes
1013	1	678	78	A	5500	Yes
1014	1	938	57	A	5500	Yes
1015	1	598	89	A	5500	Yes
1016	1	2711	20	B	5500	Yes
1017	1	925	58	B	5500	Yes
1018	1	2687	20	B	5500	Yes
1019	1	2384	23	B	5500	Yes
1020	1	534	99	B	5500	Yes
1021	1	1555	34	B	5500	Yes
1022	1	1187	45	B	5500	Yes
1023	1	1143	47	B	5500	Yes
1024	1	2099	26	B	5500	Yes
1025	1	990	54	B	5500	Yes
1026	1	881	60	B	5500	Yes
1027	1	2449	22	B	5500	Yes
1028	1	2470	22	B	5500	Yes
1029	1	2973	18	B	5500	Yes
1030	1	575	92	B	5500	Yes

TYPE 2 DETECTION PROBABILITY

Data Sheet for FCC Short Pulse Radar Type 2					
Waveform	Pulse Width (us)	PRI (us)	Pulses Per Burst	Frequency (MHz)	Successful Detection (Yes/No)
2001	4.9	175	27	5500	Yes
2002	3.1	217	28	5500	Yes
2003	3.9	211	28	5500	Yes
2004	2.3	220	26	5500	No
2005	1.5	218	23	5500	No
2006	2.3	150	29	5500	Yes
2007	3.5	195	29	5500	Yes
2008	2.6	213	25	5500	Yes
2009	2.2	224	29	5500	Yes
2010	3.4	164	26	5500	Yes
2011	1.2	179	23	5500	Yes
2012	4.8	167	24	5500	Yes
2013	2.9	186	25	5500	Yes
2014	2.6	178	29	5500	Yes
2015	4.9	163	28	5500	Yes
2016	2.9	159	25	5500	Yes
2017	3.6	230	24	5500	Yes
2018	1.8	192	26	5500	Yes
2019	2.6	229	29	5500	Yes
2020	1	195	24	5500	Yes
2021	4.3	155	27	5500	Yes
2022	1	206	27	5500	Yes
2023	4.4	170	23	5500	Yes
2024	1.3	187	23	5500	Yes
2025	5	198	27	5500	Yes
2026	4.3	220	23	5500	Yes
2027	4	154	24	5500	Yes
2028	3.5	222	28	5500	Yes
2029	1.6	161	23	5500	Yes
2030	1.3	152	27	5500	Yes

TYPE 3 DETECTION PROBABILITY

Data Sheet for FCC Short Pulse Radar Type 3					
Waveform	Pulse Width (us)	PRI (us)	Pulses Per Burst	Frequency (MHz)	Successful Detection (Yes/No)
3001	5.9	464	17	5500	Yes
3002	5.8	451	16	5500	No
3003	6.6	419	18	5500	Yes
3004	9.4	301	18	5500	Yes
3005	5.4	415	17	5500	Yes
3006	6.1	310	18	5500	Yes
3007	7.5	437	17	5500	Yes
3008	8.4	344	16	5500	Yes
3009	7.7	484	18	5500	No
3010	8.9	420	18	5500	Yes
3011	8.4	321	16	5500	Yes
3012	7.4	387	18	5500	Yes
3013	7.2	434	18	5500	Yes
3014	6.5	396	17	5500	No
3015	9.2	456	18	5500	Yes
3016	8.8	430	17	5500	Yes
3017	9.4	385	16	5500	Yes
3018	9.3	254	16	5500	Yes
3019	5	473	17	5500	Yes
3020	7.8	424	16	5500	Yes
3021	7.9	287	16	5500	Yes
3022	8.6	433	17	5500	Yes
3023	10	309	18	5500	Yes
3024	5.8	467	18	5500	Yes
3025	5.1	489	16	5500	Yes
3026	6.3	292	16	5500	No
3027	5.8	444	18	5500	Yes
3028	9.9	392	16	5500	Yes
3029	9.7	306	17	5500	Yes
3030	9	268	16	5500	Yes

TYPE 4 DETECTION PROBABILITY

Data Sheet for FCC Short Pulse Radar Type 4					
Waveform	Pulse Width (us)	PRI (us)	Pulses Per Burst	Frequency (MHz)	Successful Detection (Yes/No)
4001	13.3	328	13	5500	Yes
4002	17.9	435	16	5500	Yes
4003	13.6	257	15	5500	Yes
4004	18.7	377	16	5500	Yes
4005	15	345	15	5500	Yes
4006	10.5	478	16	5500	Yes
4007	12.7	459	15	5500	Yes
4008	14.1	354	15	5500	Yes
4009	16.7	480	14	5500	Yes
4010	18.6	270	14	5500	Yes
4011	17.1	410	16	5500	Yes
4012	19.5	463	16	5500	Yes
4013	18.5	364	16	5500	Yes
4014	16.6	313	16	5500	Yes
4015	16.1	478	12	5500	Yes
4016	14.8	439	15	5500	Yes
4017	10.1	382	16	5500	Yes
4018	14.7	356	12	5500	Yes
4019	10.4	429	13	5500	Yes
4020	15.5	298	14	5500	Yes
4021	11.8	266	13	5500	No
4022	17.4	399	14	5500	Yes
4023	14.8	379	14	5500	Yes
4024	10.9	274	13	5500	Yes
4025	13.5	401	13	5500	Yes
4026	15.4	442	12	5500	Yes
4027	13.9	330	15	5500	Yes
4028	16.3	384	14	5500	No
4029	15.3	285	15	5500	Yes
4030	13.5	485	15	5500	Yes

TYPE 5 DETECTION PROBABILITY

Data Sheet for FCC Long Pulse Radar Type 5		
Trial	Frequency (MHz)	Successful Detection (Yes/No)
1	5501	Yes
2	5500	No
3	5495	Yes
4	5499	Yes
5	5495	Yes
6	5496	Yes
7	5495	No
8	5499	Yes
9	5499	No
10	5506	Yes
11	5505	Yes
12	5498	Yes
13	5504	Yes
14	5495	Yes
15	5502	Yes
16	5501	Yes
17	5504	Yes
18	5502	Yes
19	5507	Yes
20	5504	Yes
21	5502	Yes
22	5494	Yes
23	5495	Yes
24	5505	Yes
25	5505	Yes
26	5506	Yes
27	5497	Yes
28	5505	No
29	5504	Yes
30	5500	Yes

Note: The Type 5 randomized parameters tested are shown in a separate document.

TYPE 6 DETECTION PROBABILITY

Data Sheet for FCC Hopping Radar Type 6				
1 us Pulse Width, 333 us PRI, 9 Pulses per Burst, 1 Burst per Hop				
NTIA August 2005 Hopping Sequence				
Trial	Starting Index Within Sequence	Signal Generator Frequency (MHz)	Hops within Detection BW	Successful Detection (Yes/No)
1	70	5491	4	Yes
2	545	5492	5	Yes
3	1020	5493	5	Yes
4	1495	5494	4	Yes
5	1970	5495	5	Yes
6	2445	5496	6	Yes
7	2920	5497	7	Yes
8	3395	5498	2	Yes
9	3870	5499	4	Yes
10	4345	5500	4	Yes
11	4820	5501	5	Yes
12	5295	5502	6	Yes
13	5770	5503	3	Yes
14	6245	5504	6	Yes
15	6720	5505	3	Yes
16	7195	5506	4	Yes
17	7670	5507	4	Yes
18	8145	5508	3	Yes
19	8620	5509	4	Yes
20	9095	5491	4	Yes
21	9570	5492	3	Yes
22	10045	5493	5	Yes
23	10520	5494	1	Yes
24	10995	5495	4	Yes
25	11470	5496	5	Yes
26	11945	5497	10	Yes
27	12420	5498	3	Yes
28	12895	5499	6	Yes
29	13370	5500	5	Yes
30	13845	5501	2	Yes
31	14320	5502	6	Yes
32	14795	5503	2	Yes
33	15270	5504	4	Yes
34	15745	5505	3	Yes
35	16220	5506	2	Yes
36	16695	5507	4	Yes
37	17170	5508	2	Yes
38	17645	5509	5	Yes

5.3. RESULTS FOR 40 MHz BANDWIDTH

5.3.1. TEST CHANNEL

All tests were performed at a channel center frequency of 5510 MHz.

5.3.2. RADAR WAVEFORMS AND TRAFFIC

RADAR WAVEFORMS

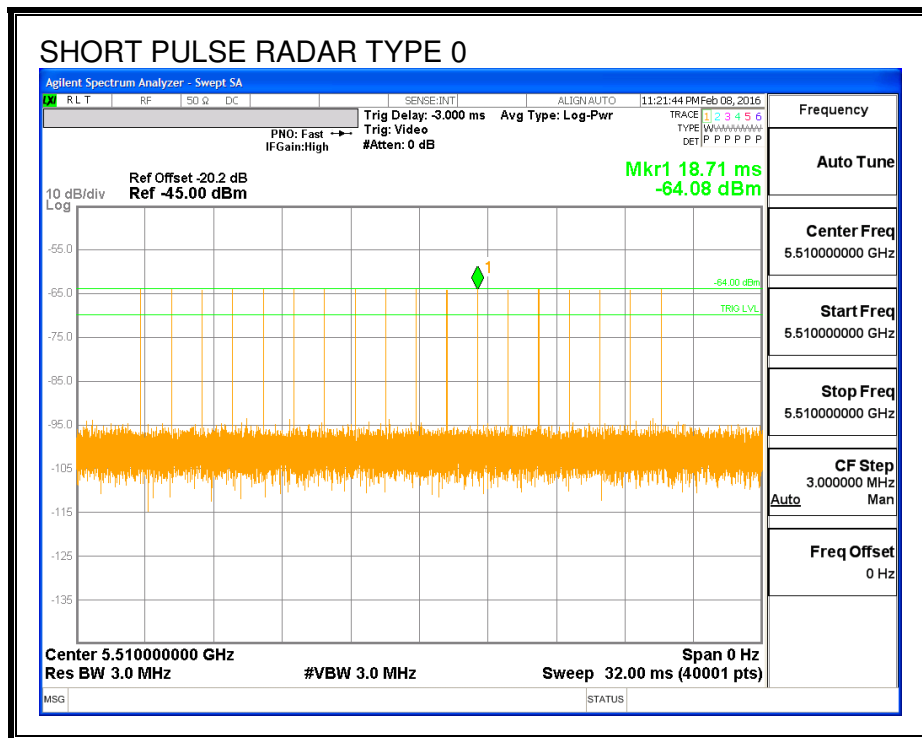

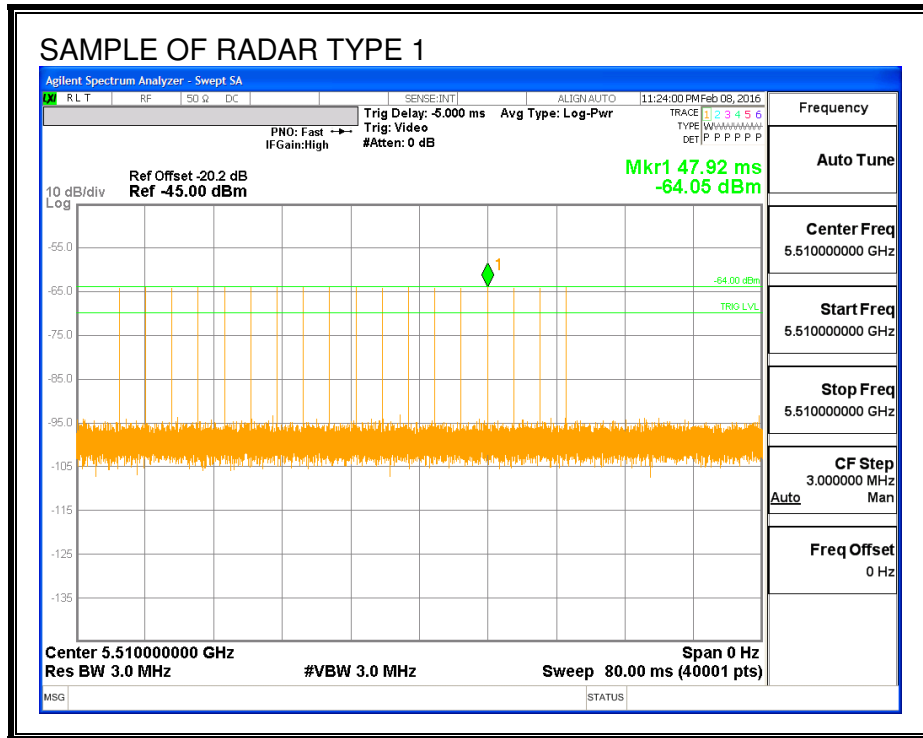

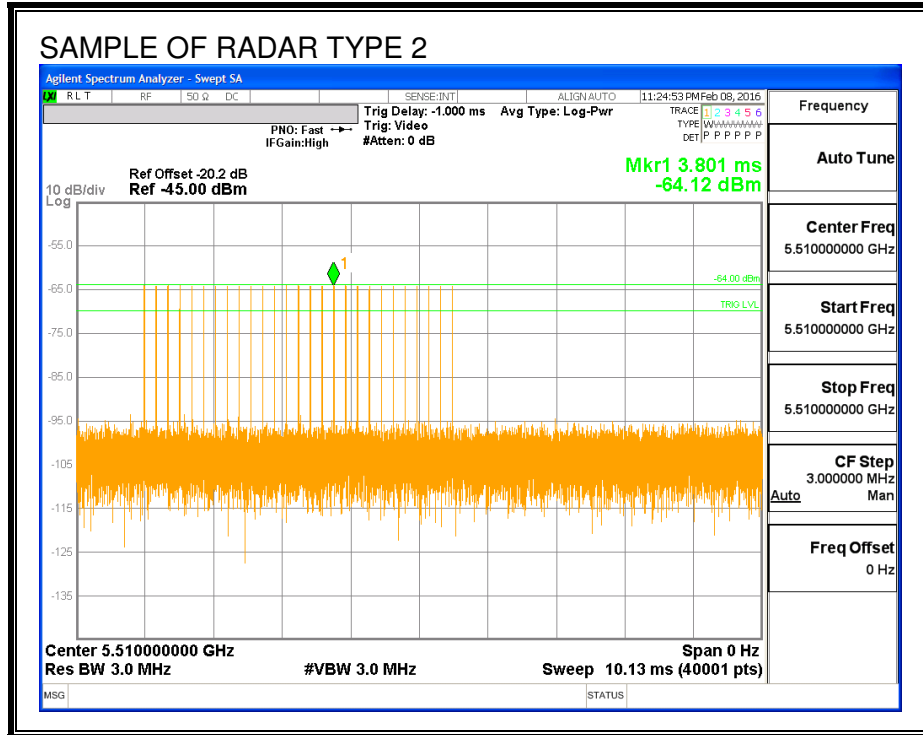

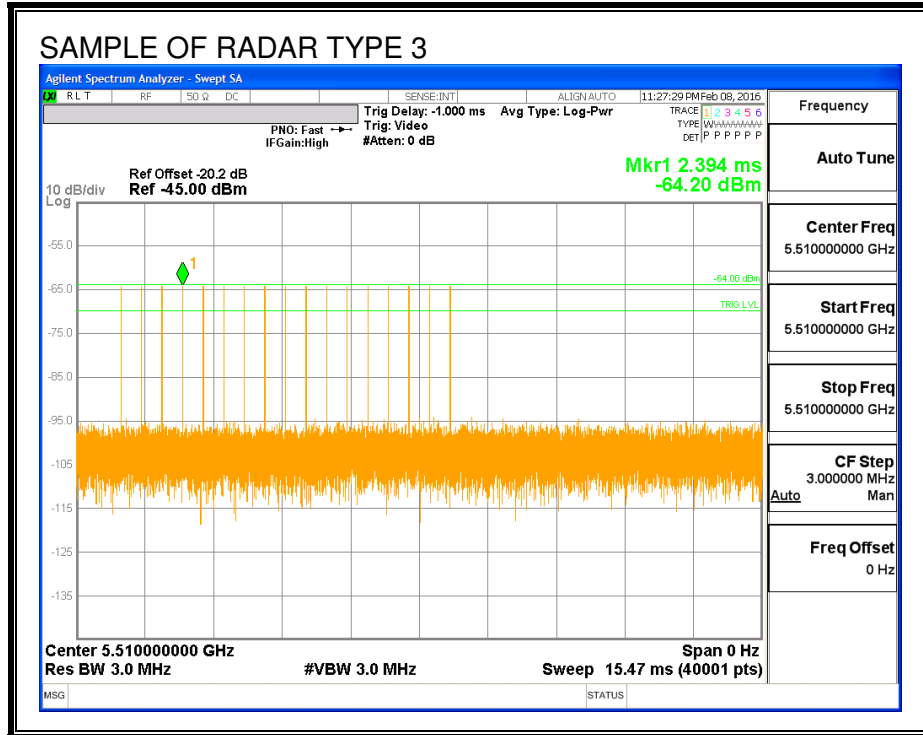

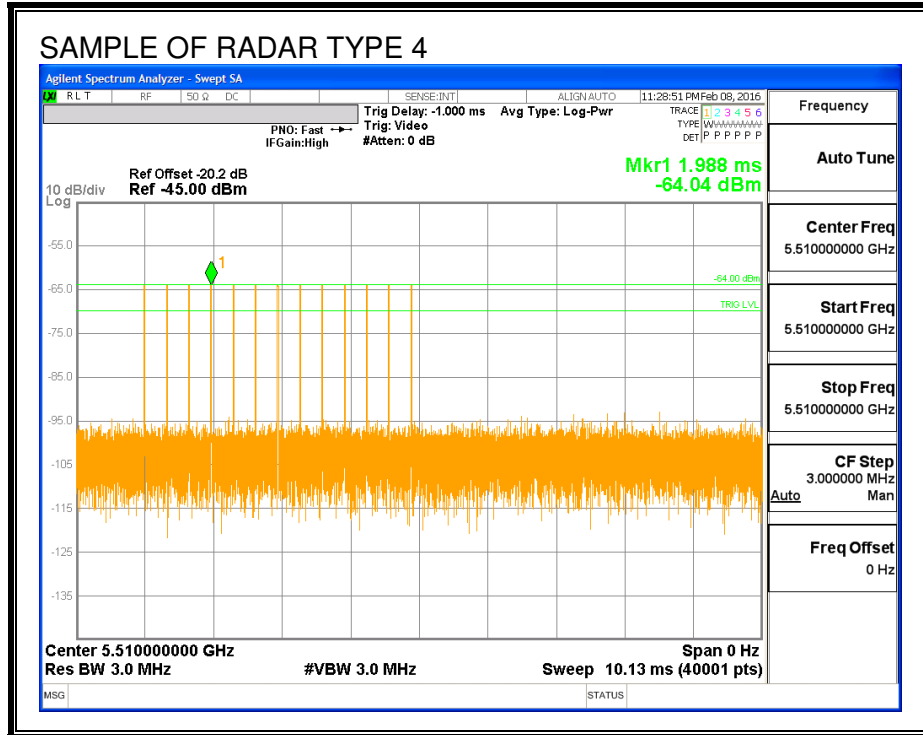

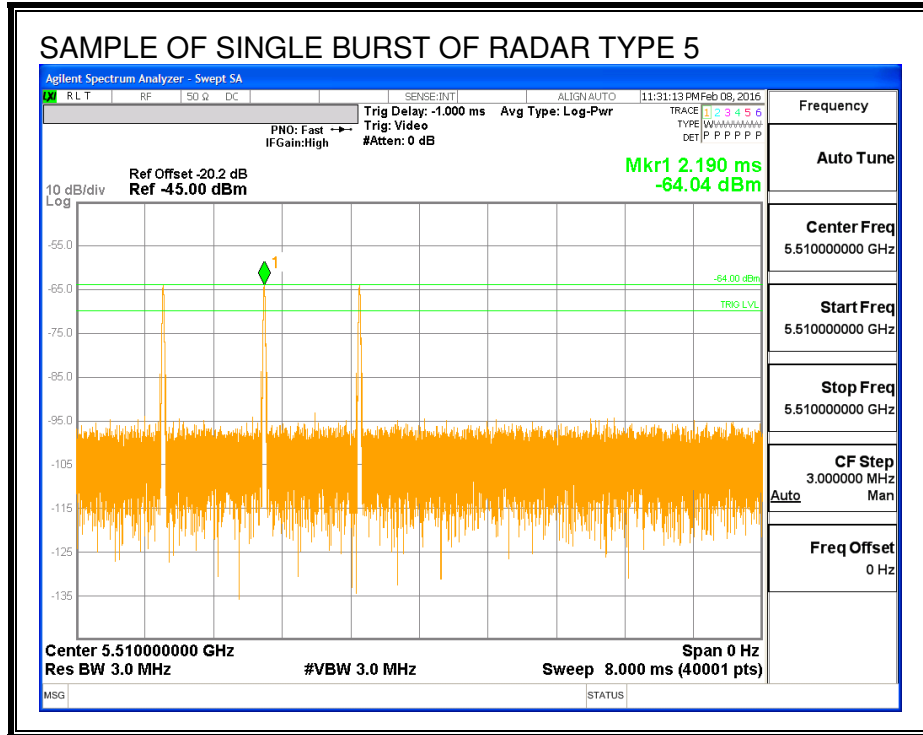

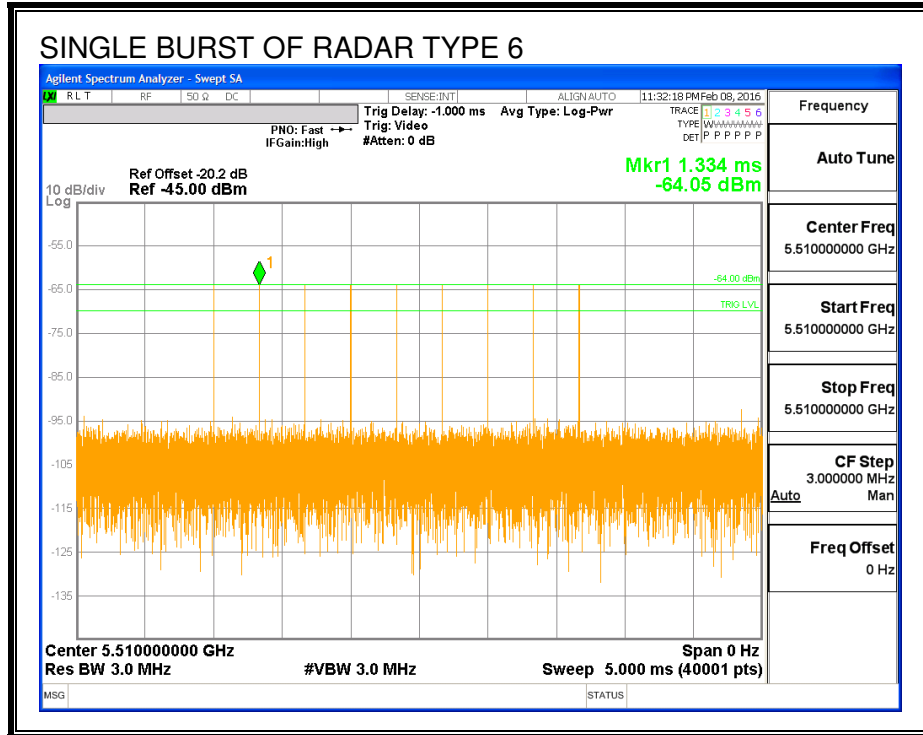

TRAFFIC

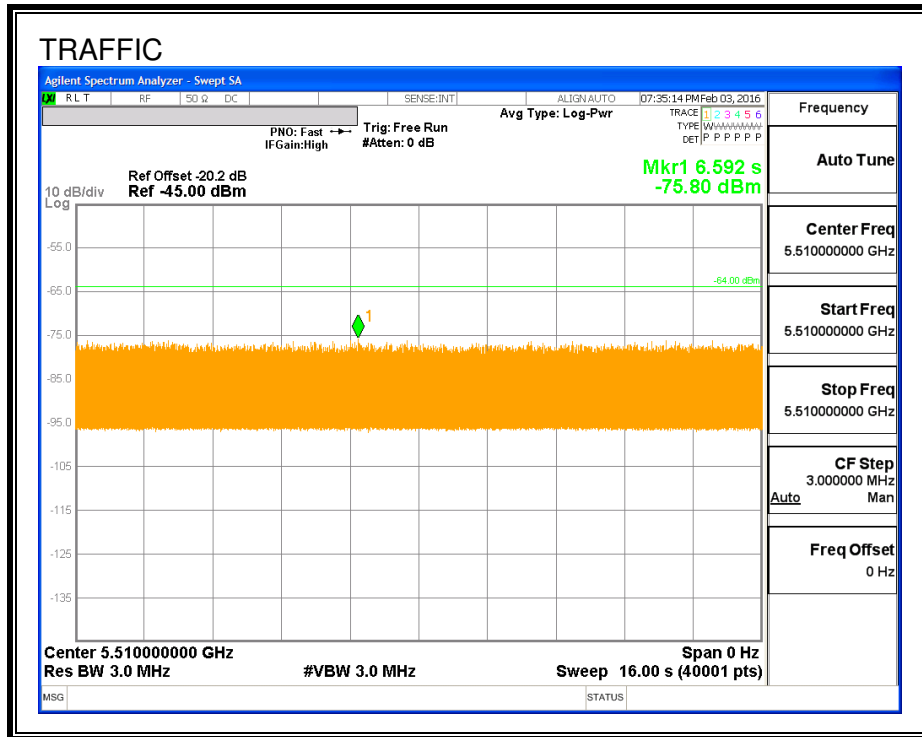

CHANNEL LOADING

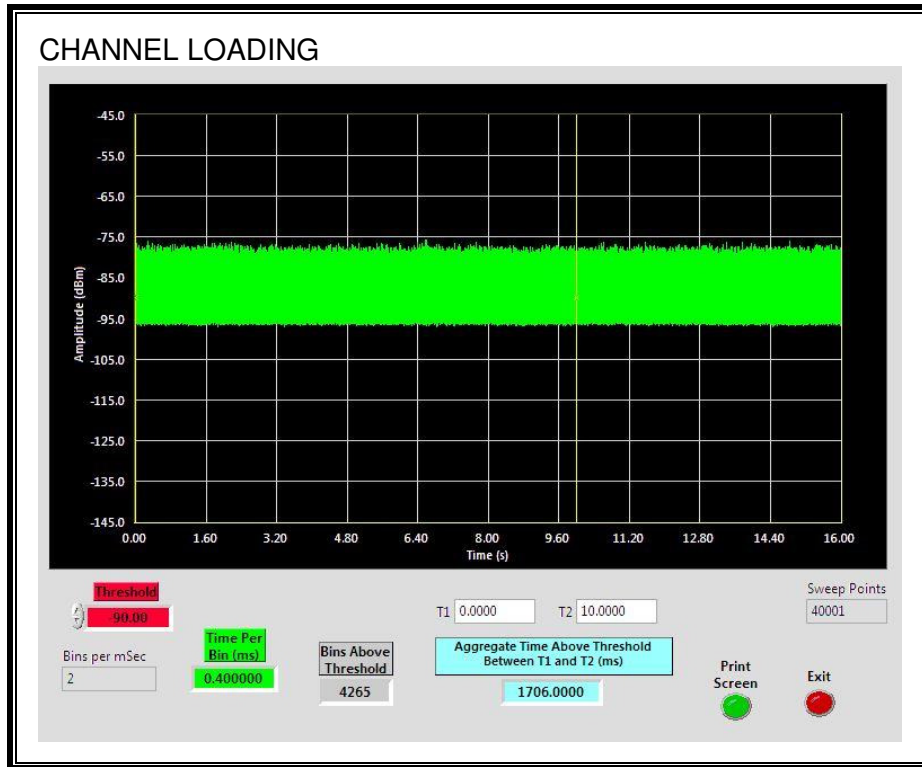

The level of traffic loading on the channel by the EUT is 17.06%

5.3.3. CHANNEL AVAILABILITY CHECK TIME

PROCEDURE TO DETERMINE INITIAL POWER-UP CYCLE TIME

A link was established on channel then the EUT was rebooted. The time from the cessation of traffic to the re-initialization of traffic was measured as the time required for the EUT to complete the total power-up cycle. The time to complete the initial power-up period is 60 seconds less than this total power-up time.

PROCEDURE FOR TIMING OF RADAR BURST

With a link established on channel, the EUT was rebooted. A radar signal was triggered within 0 to 6 seconds after the initial power-up period, and transmissions on the channel were monitored on the spectrum analyzer.

The Non-Occupancy list was cleared. With a link established on channel, the EUT was rebooted. A radar signal was triggered within 54 to 60 seconds after the initial power-up period, and transmissions on the channel were monitored on the spectrum analyzer.

QUANTITATIVE RESULTS

No Radar Triggered

Timing of Reboot (sec)	Timing of Start of Traffic (sec)	Total Power-up Cycle Time (sec)	Initial Power-up Cycle Time (sec)
29.99	159.6	129.6	69.6

Radar Near Beginning of CAC

Timing of Reboot (sec)	Timing of Radar Burst (sec)	Radar Relative to Reboot (sec)	Radar Relative to Start of CAC (sec)
30.34	100.9	70.6	1.0

Radar Near End of CAC

Timing of Reboot (sec)	Timing of Radar Burst (sec)	Radar Relative to Reboot (sec)	Radar Relative to Start of CAC (sec)
30.22	158.4	128.2	58.6

QUALITATIVE RESULTS

Timing of Radar Burst	Display on Control Computer	Spectrum Analyzer Display
No Radar Triggered	EUT marks Channel as active	Transmissions begin on channel after completion of the initial power-up cycle and the CAC
Within 0 to 6 second window	EUT indicates radar detected	No transmissions on channel
Within 54 to 60 second window	EUT indicates radar detected	No transmissions on channel

TIMING WITHOUT RADAR DURING CAC

AP is rebooted
 Traffic ceases
 Start of Initial Power-up cycle

End of Initial Power-up cycle
 Start of CAC

End of CAC
 Traffic is Initiated

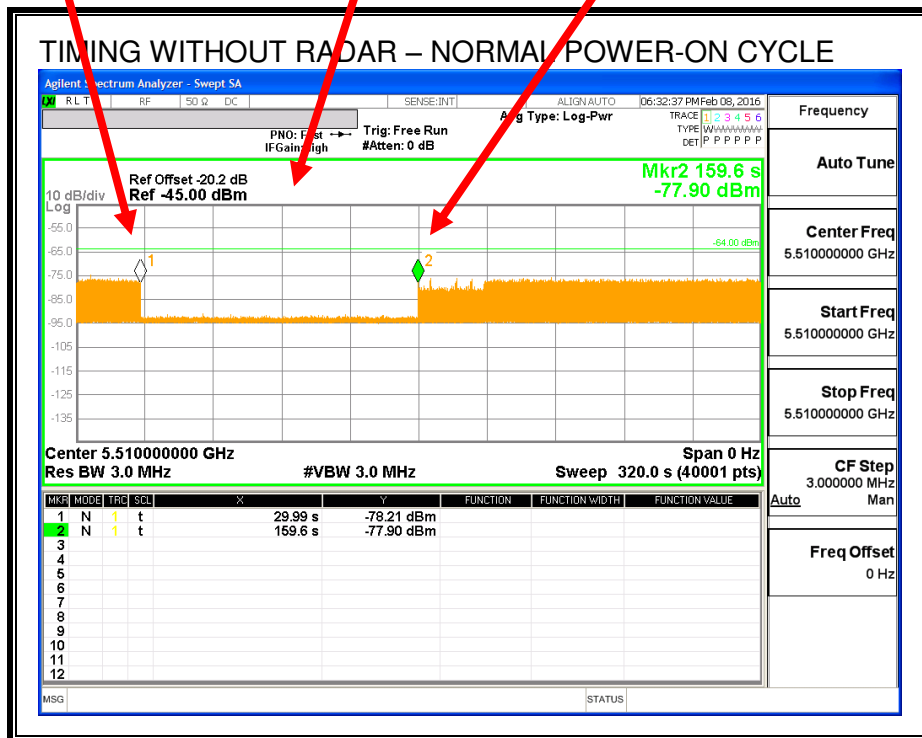

Transmissions begin on channel after completion of the initial power-up cycle and the CAC.

TIMING WITH RADAR NEAR BEGINNING OF CAC

AP is rebooted
 Traffic ceases
 Start of Initial Power-up cycle

End of Initial Power-up cycle
 Start of CAC

Radar Signal Applied

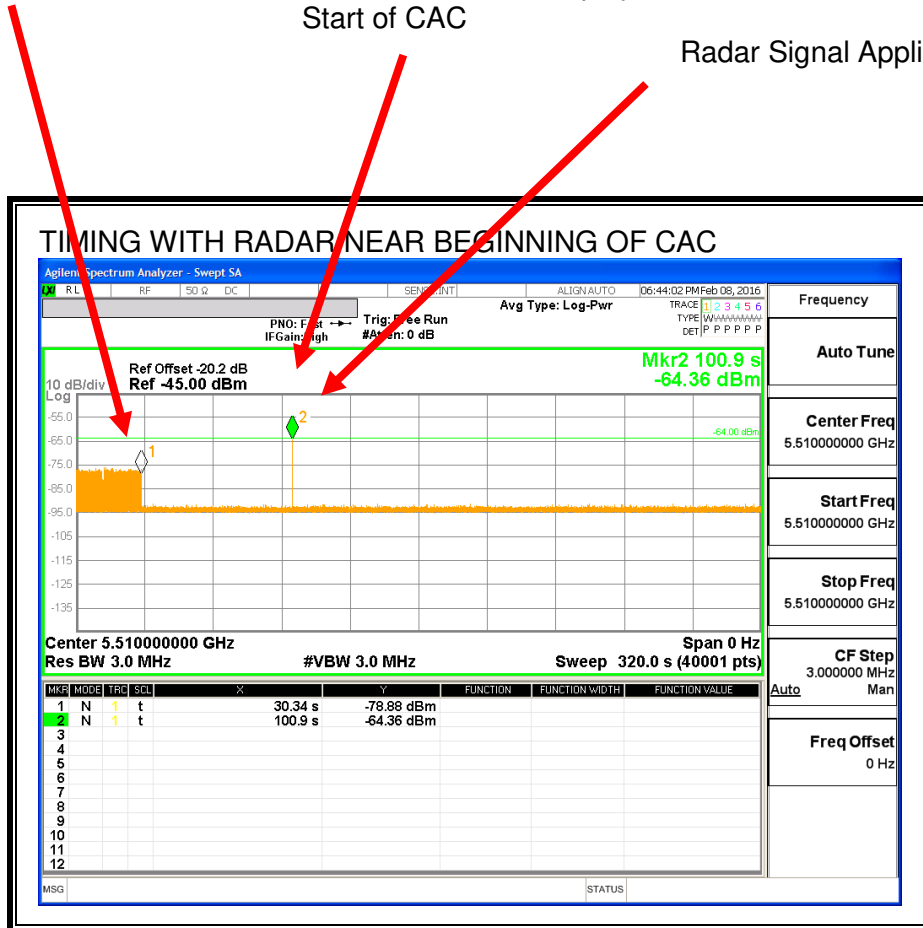

No EUT transmissions were observed after the radar signal.

TIMING WITH RADAR NEAR END OF CAC

AP is rebooted
 Traffic ceases
 Start of Initial Power-up cycle

End of Initial Power-up cycle
 Start of CAC

Radar Signal Applied

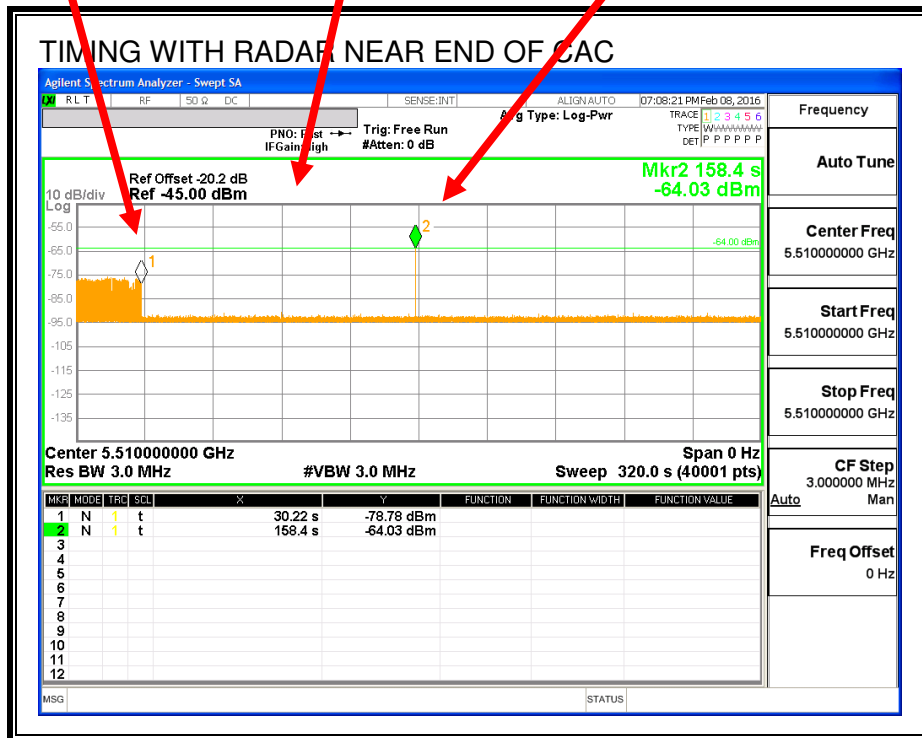

No EUT transmissions were observed after the radar signal.

5.3.1. OVERLAPPING CHANNEL TESTS

RESULTS

The channel spacing is not less than the channel bandwidth therefore the EUT does not have an overlapping channel plan.

These tests are not applicable.

5.3.2. MOVE AND CLOSING TIME

REPORTING NOTES

The reference marker is set at the end of last radar pulse.

The delta marker is set at the end of the last WLAN transmission following the radar pulse. This delta is the channel move time.

The aggregate channel closing transmission time is calculated as follows:

Aggregate Transmission Time =
(Number of analyzer bins showing transmission) * (dwell time per bin)

The observation period over which the aggregate time is calculated begins at (Reference Marker + 200 msec) and ends no earlier than (Reference Marker + 10 sec).

RESULTS

Channel Move Time (sec)	Limit (sec)
0.224	10

Aggregate Channel Closing Transmission Time (msec)	Limit (msec)
1.6	60

MOVE TIME

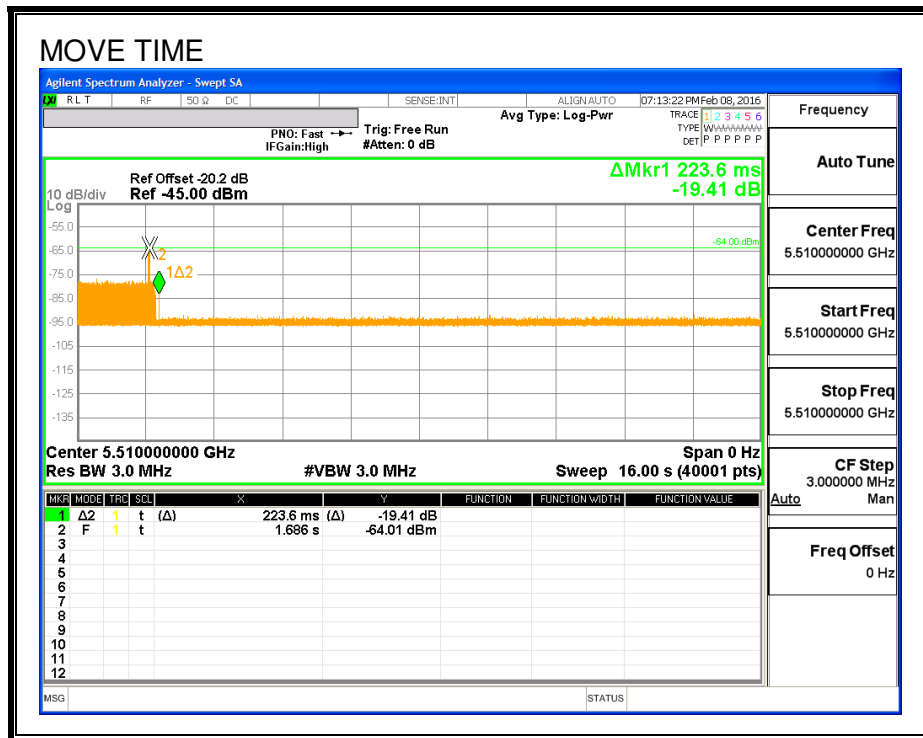

CHANNEL CLOSING TIME

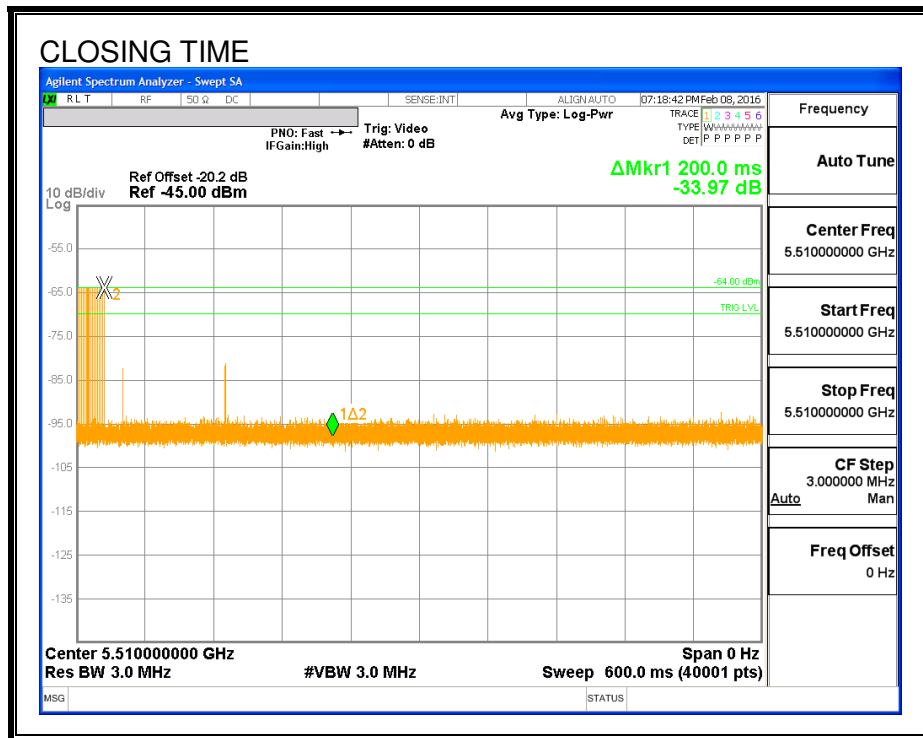

AGGREGATE CHANNEL CLOSING TRANSMISSION TIME

Only intermittent transmissions are observed during the aggregate monitoring period.

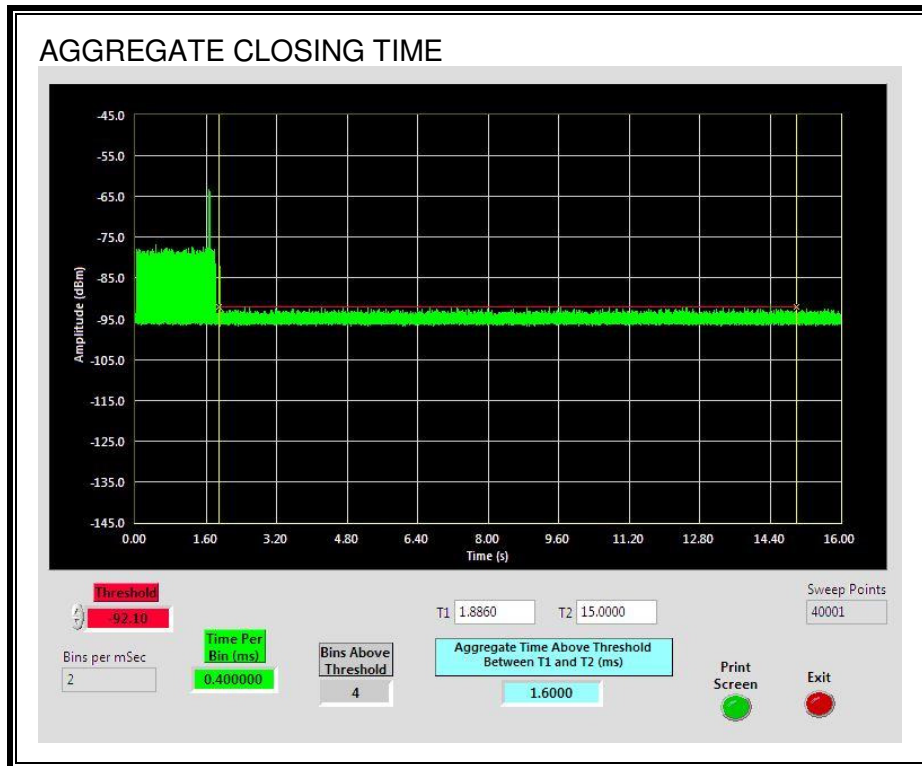

LONG PULSE CHANNEL MOVE TIME

The traffic ceases prior to 10 seconds after the end of the radar waveform.

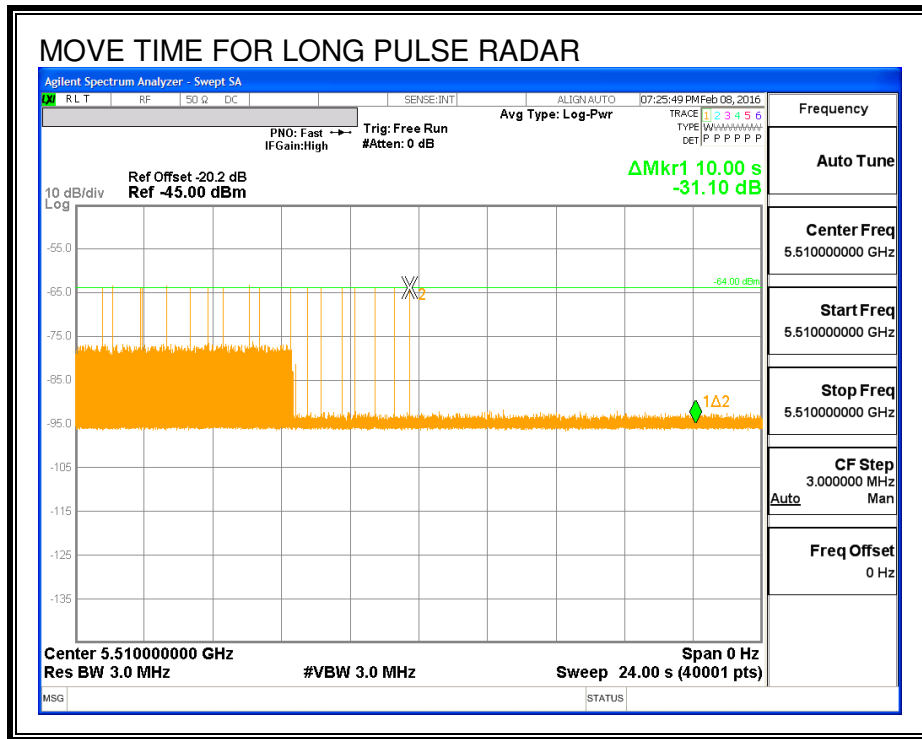

5.3.1. NON-OCCUPANCY PERIOD

RESULTS

No EUT transmissions were observed on the test channel during the 30-minute observation time.

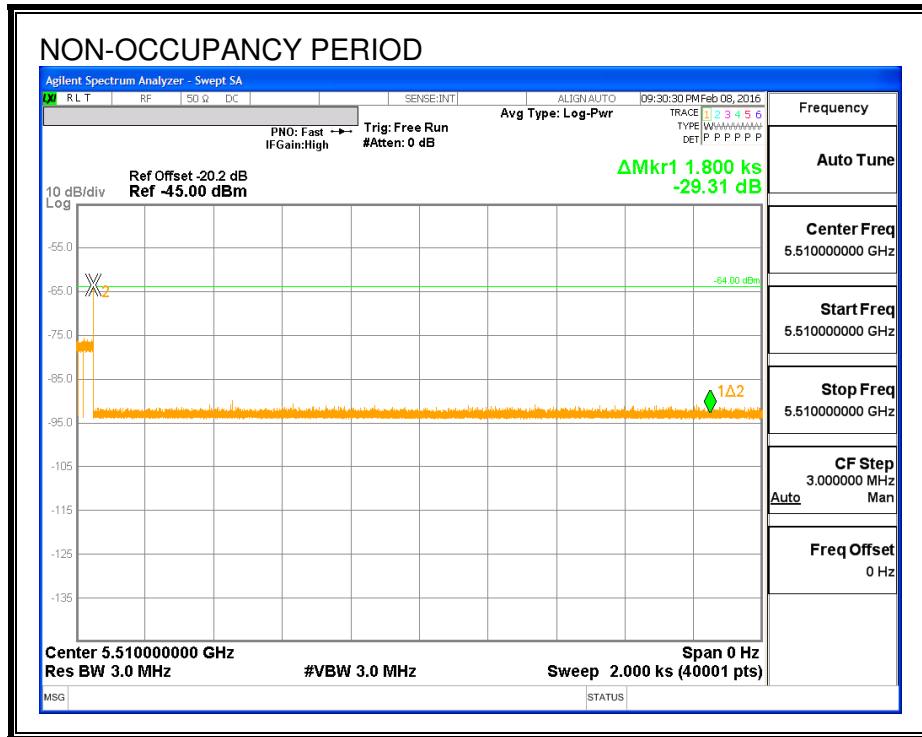

5.3.2. DETECTION BANDWIDTH

REFERENCE PLOT OF 99% POWER BANDWIDTH

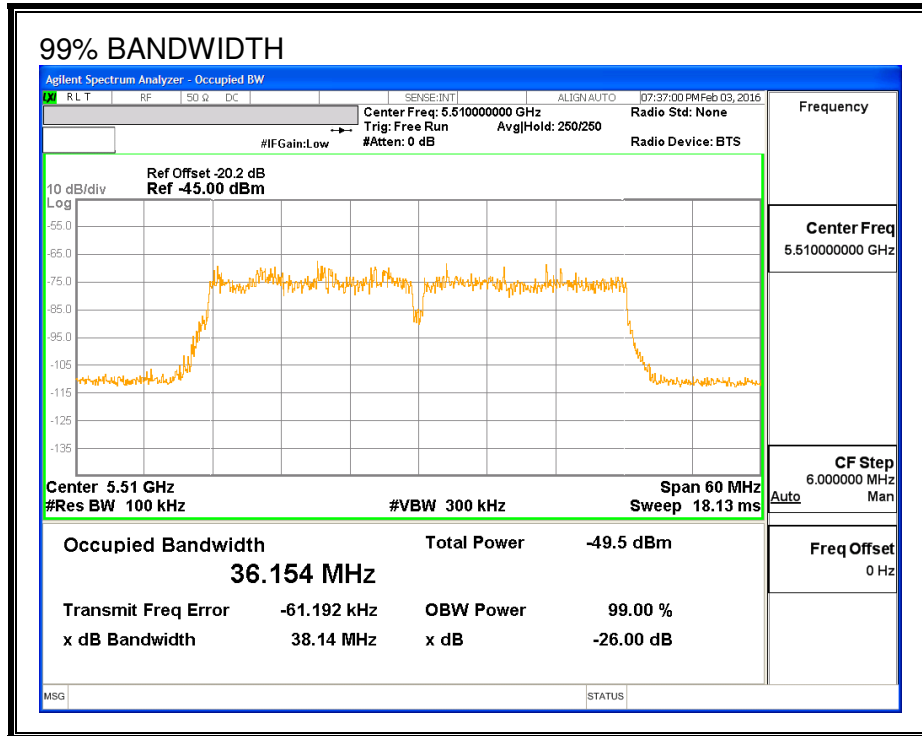

RESULTS

FL	FH	Detection Bandwidth	99% Power Bandwidth	Ratio of Detection BW to 99% Power BW	Minimum Limit
(MHz)	(MHz)	(MHz)	(MHz)	(%)	(%)
5491	5528	37	36.154	102.3	100

DETECTION BANDWIDTH PROBABILITY

DETECTION BANDWIDTH PROBABILITY RESULTS				
Detection Bandwidth Test Results				
FCC Type 0 Waveform: 1 us Pulse Width, 1428 us PRI, 18 Pulses per Burst				
Frequency (MHz)	Number of Trials	Number Detected	Detection (%)	Mark
5490	10	0	0	
5491	10	10	100	FL
5492	10	10	100	
5493	10	10	100	
5494	10	10	100	
5495	10	10	100	
5500	10	10	100	
5505	10	10	100	
5510	10	9	90	
5515	10	10	100	
5520	10	10	100	
5525	10	10	100	
5526	10	10	100	
5527	10	10	100	
5528	10	10	100	FH
5529	10	5	50	

5.3.3. IN-SERVICE MONITORING

RESULTS

FCC Radar Test Summary								
Signal Type	Number of Trials	Detection (%)	Limit (%)	Pass/Fail	Detection Bandwidth		80% of Det BW	
					FL	FH	FL5	FH5
FCC Short Pulse Type 1	30	96.67	60	Pass	5491	5528		
FCC Short Pulse Type 2	30	93.33	60	Pass	5491	5528		
FCC Short Pulse Type 3	30	93.33	60	Pass	5491	5528		
FCC Short Pulse Type 4	30	96.67	60	Pass	5491	5528		
Aggregate		95.00	80	Pass				
FCC Long Pulse Type 5	30	96.67	80	Pass	5491	5528	5495	5524
FCC Hopping Type 6	38	100.00	70	Pass	5491	5528		

TYPE 1 DETECTION PROBABILITY

Data Sheet for FCC Short Pulse Radar Type 1						
Waveform	Pulse Width (us)	PRI (us)	Pulses Per Burst	Test (A/B)	Frequency (MHz)	Successful Detection (Yes/No)
1001	1	3066	18	A	5510	No
1002	1	758	70	A	5510	Yes
1003	1	738	72	A	5510	Yes
1004	1	558	95	A	5510	Yes
1005	1	658	81	A	5510	Yes
1006	1	918	58	A	5510	Yes
1007	1	798	67	A	5510	Yes
1008	1	638	83	A	5510	Yes
1009	1	858	62	A	5510	Yes
1010	1	578	92	A	5510	Yes
1011	1	698	76	A	5510	Yes
1012	1	818	65	A	5510	Yes
1013	1	678	78	A	5510	Yes
1014	1	938	57	A	5510	Yes
1015	1	598	89	A	5510	Yes
1016	1	2711	20	B	5510	Yes
1017	1	925	58	B	5510	Yes
1018	1	2687	20	B	5510	Yes
1019	1	2384	23	B	5510	Yes
1020	1	534	99	B	5510	Yes
1021	1	1555	34	B	5510	Yes
1022	1	1187	45	B	5510	Yes
1023	1	1143	47	B	5510	Yes
1024	1	2099	26	B	5510	Yes
1025	1	990	54	B	5510	Yes
1026	1	881	60	B	5510	Yes
1027	1	2449	22	B	5510	Yes
1028	1	2470	22	B	5510	Yes
1029	1	2973	18	B	5510	Yes
1030	1	575	92	B	5510	Yes

TYPE 2 DETECTION PROBABILITY

Data Sheet for FCC Short Pulse Radar Type 2					
Waveform	Pulse Width (us)	PRI (us)	Pulses Per Burst	Frequency (MHz)	Successful Detection (Yes/No)
2001	4.9	175	27	5510	No
2002	3.1	217	28	5510	Yes
2003	3.9	211	28	5510	Yes
2004	2.3	220	26	5510	Yes
2005	1.5	218	23	5510	Yes
2006	2.3	150	29	5510	No
2007	3.5	195	29	5510	Yes
2008	2.6	213	25	5510	Yes
2009	2.2	224	29	5510	Yes
2010	3.4	164	26	5510	Yes
2011	1.2	179	23	5510	Yes
2012	4.8	167	24	5510	Yes
2013	2.9	186	25	5510	Yes
2014	2.6	178	29	5510	Yes
2015	4.9	163	28	5510	Yes
2016	2.9	159	25	5510	Yes
2017	3.6	230	24	5510	Yes
2018	1.8	192	26	5510	Yes
2019	2.6	229	29	5510	Yes
2020	1	195	24	5510	Yes
2021	4.3	155	27	5510	Yes
2022	1	206	27	5510	Yes
2023	4.4	170	23	5510	Yes
2024	1.3	187	23	5510	Yes
2025	5	198	27	5510	Yes
2026	4.3	220	23	5510	Yes
2027	4	154	24	5510	Yes
2028	3.5	222	28	5510	Yes
2029	1.6	161	23	5510	Yes
2030	1.3	152	27	5510	Yes

TYPE 3 DETECTION PROBABILITY

Data Sheet for FCC Short Pulse Radar Type 3					
Waveform	Pulse Width (us)	PRI (us)	Pulses Per Burst	Frequency (MHz)	Successful Detection (Yes/No)
3001	5.9	464	17	5510	Yes
3002	5.8	451	16	5510	Yes
3003	6.6	419	18	5510	Yes
3004	9.4	301	18	5510	Yes
3005	5.4	415	17	5510	Yes
3006	6.1	310	18	5510	Yes
3007	7.5	437	17	5510	Yes
3008	8.4	344	16	5510	Yes
3009	7.7	484	18	5510	Yes
3010	8.9	420	18	5510	Yes
3011	8.4	321	16	5510	Yes
3012	7.4	387	18	5510	Yes
3013	7.2	434	18	5510	Yes
3014	6.5	396	17	5510	Yes
3015	9.2	456	18	5510	Yes
3016	8.8	430	17	5510	Yes
3017	9.4	385	16	5510	Yes
3018	9.3	254	16	5510	Yes
3019	5	473	17	5510	Yes
3020	7.8	424	16	5510	Yes
3021	7.9	287	16	5510	Yes
3022	8.6	433	17	5510	Yes
3023	10	309	18	5510	No
3024	5.8	467	18	5510	Yes
3025	5.1	489	16	5510	Yes
3026	6.3	292	16	5510	Yes
3027	5.8	444	18	5510	Yes
3028	9.9	392	16	5510	Yes
3029	9.7	306	17	5510	No
3030	9	268	16	5510	Yes

TYPE 4 DETECTION PROBABILITY

Data Sheet for FCC Short Pulse Radar Type 4					
Waveform	Pulse Width (us)	PRI (us)	Pulses Per Burst	Frequency (MHz)	Successful Detection (Yes/No)
4001	13.3	328	13	5510	Yes
4002	17.9	435	16	5510	Yes
4003	13.6	257	15	5510	No
4004	18.7	377	16	5510	Yes
4005	15	345	15	5510	Yes
4006	10.5	478	16	5510	Yes
4007	12.7	459	15	5510	Yes
4008	14.1	354	15	5510	Yes
4009	16.7	480	14	5510	Yes
4010	18.6	270	14	5510	Yes
4011	17.1	410	16	5510	Yes
4012	19.5	463	16	5510	Yes
4013	18.5	364	16	5510	Yes
4014	16.6	313	16	5510	Yes
4015	16.1	478	12	5510	Yes
4016	14.8	439	15	5510	Yes
4017	10.1	382	16	5510	Yes
4018	14.7	356	12	5510	Yes
4019	10.4	429	13	5510	Yes
4020	15.5	298	14	5510	Yes
4021	11.8	266	13	5510	Yes
4022	17.4	399	14	5510	Yes
4023	14.8	379	14	5510	Yes
4024	10.9	274	13	5510	Yes
4025	13.5	401	13	5510	Yes
4026	15.4	442	12	5510	Yes
4027	13.9	330	15	5510	Yes
4028	16.3	384	14	5510	Yes
4029	15.3	285	15	5510	Yes
4030	13.5	485	15	5510	Yes

TYPE 5 DETECTION PROBABILITY

Data Sheet for FCC Long Pulse Radar Type 5		
Trial	Frequency (MHz)	Successful Detection (Yes/No)
1	5502	No
2	5519	Yes
3	5516	Yes
4	5507	Yes
5	5505	Yes
6	5520	Yes
7	5511	Yes
8	5506	Yes
9	5511	Yes
10	5501	Yes
11	5524	Yes
12	5511	Yes
13	5501	Yes
14	5524	Yes
15	5503	Yes
16	5510	Yes
17	5517	Yes
18	5522	Yes
19	5499	Yes
20	5500	Yes
21	5504	Yes
22	5495	Yes
23	5509	Yes
24	5498	Yes
25	5521	Yes
26	5520	Yes
27	5522	Yes
28	5497	Yes
29	5508	Yes
30	5512	Yes

Note: The Type 5 randomized parameters tested are shown in a separate document.

TYPE 6 DETECTION PROBABILITY

Data Sheet for FCC Hopping Radar Type 6				
1 us Pulse Width, 333 us PRI, 9 Pulses per Burst, 1 Burst per Hop				
NTIA August 2005 Hopping Sequence				
Trial	Starting Index Within Sequence	Signal Generator Frequency (MHz)	Hops within Detection BW	Successful Detection (Yes/No)
1	281	5491	8	Yes
2	756	5492	10	Yes
3	1231	5493	10	Yes
4	1706	5494	8	Yes
5	2181	5495	5	Yes
6	2656	5496	12	Yes
7	3131	5497	8	Yes
8	3606	5498	8	Yes
9	4081	5499	6	Yes
10	4556	5500	7	Yes
11	5031	5501	4	Yes
12	5506	5502	8	Yes
13	5981	5503	8	Yes
14	6456	5504	8	Yes
15	6931	5505	8	Yes
16	7406	5506	6	Yes
17	7881	5507	8	Yes
18	8356	5508	9	Yes
19	8831	5509	10	Yes
20	9306	5510	9	Yes
21	9781	5511	10	Yes
22	10256	5512	11	Yes
23	10731	5513	7	Yes
24	11206	5514	11	Yes
25	11681	5515	7	Yes
26	12156	5516	8	Yes
27	12631	5517	6	Yes
28	13106	5518	7	Yes
29	13581	5519	6	Yes
30	14056	5520	13	Yes
31	14531	5521	7	Yes
32	15006	5522	4	Yes
33	15481	5523	7	Yes
34	15956	5524	10	Yes
35	16431	5525	8	Yes
36	16906	5526	6	Yes
37	17381	5527	7	Yes
38	17856	5528	10	Yes

5.4. RESULTS FOR 80 MHz BANDWIDTH

5.4.1. TEST CHANNEL

All tests were performed at a channel center frequency of 5530 MHz.

5.4.2. RADAR WAVEFORMS AND TRAFFIC

RADAR WAVEFORMS

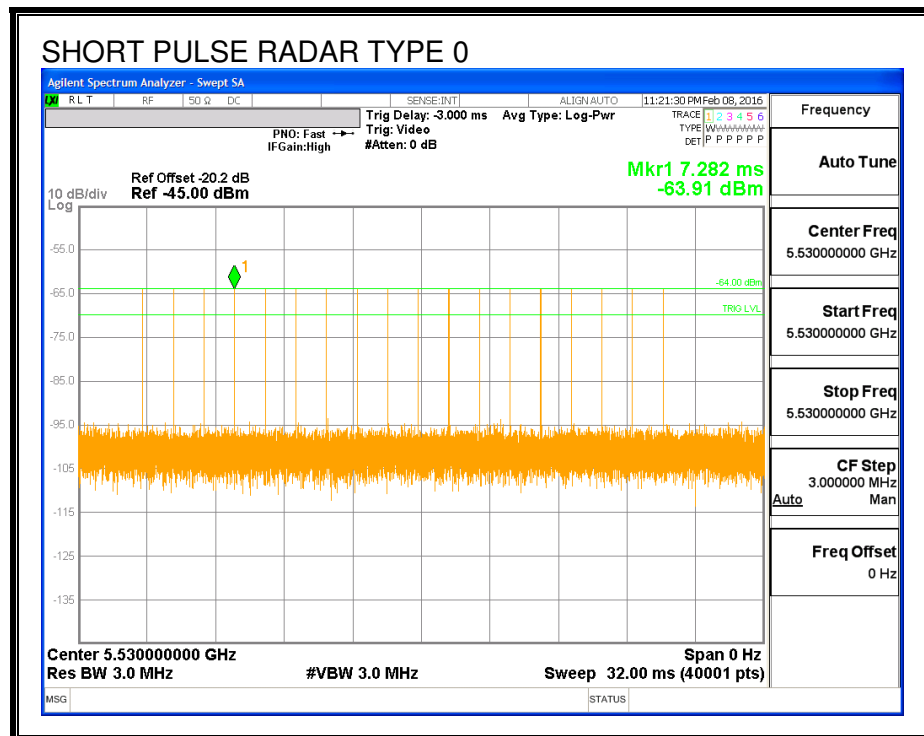

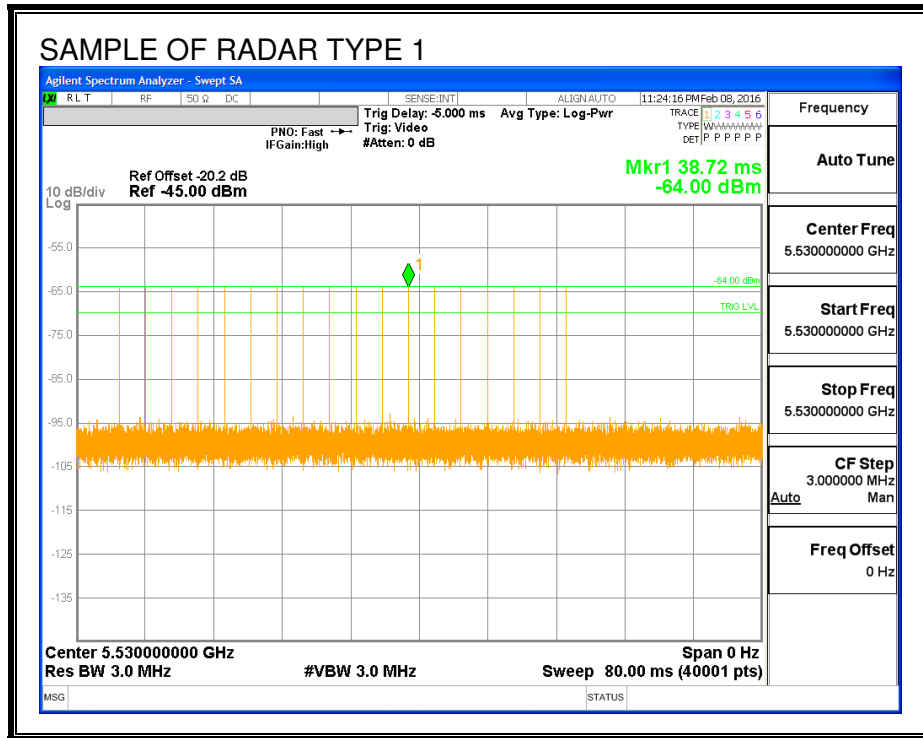

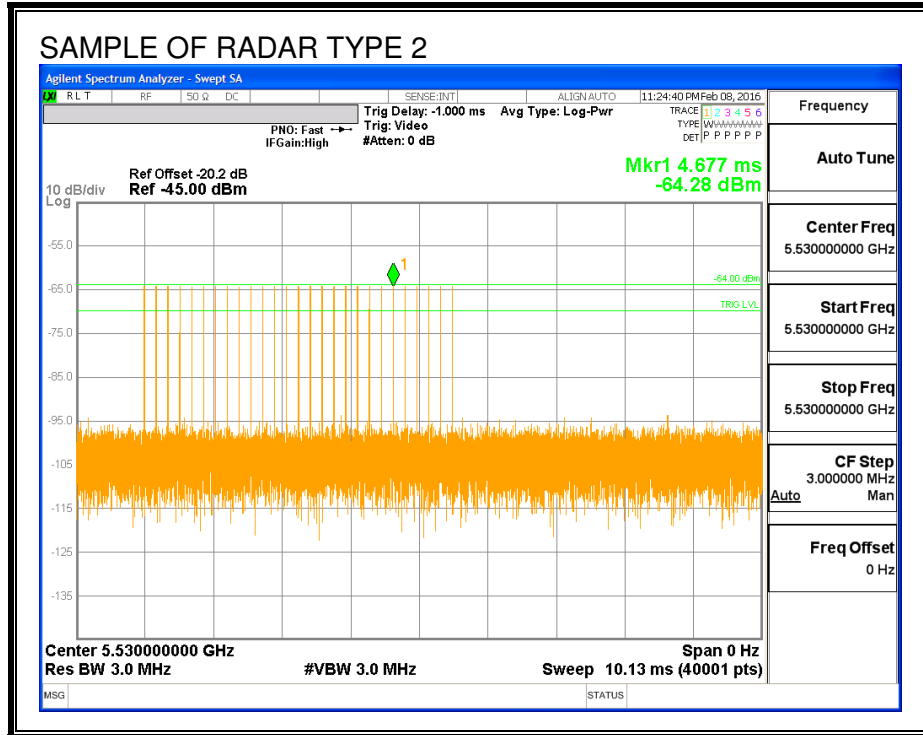

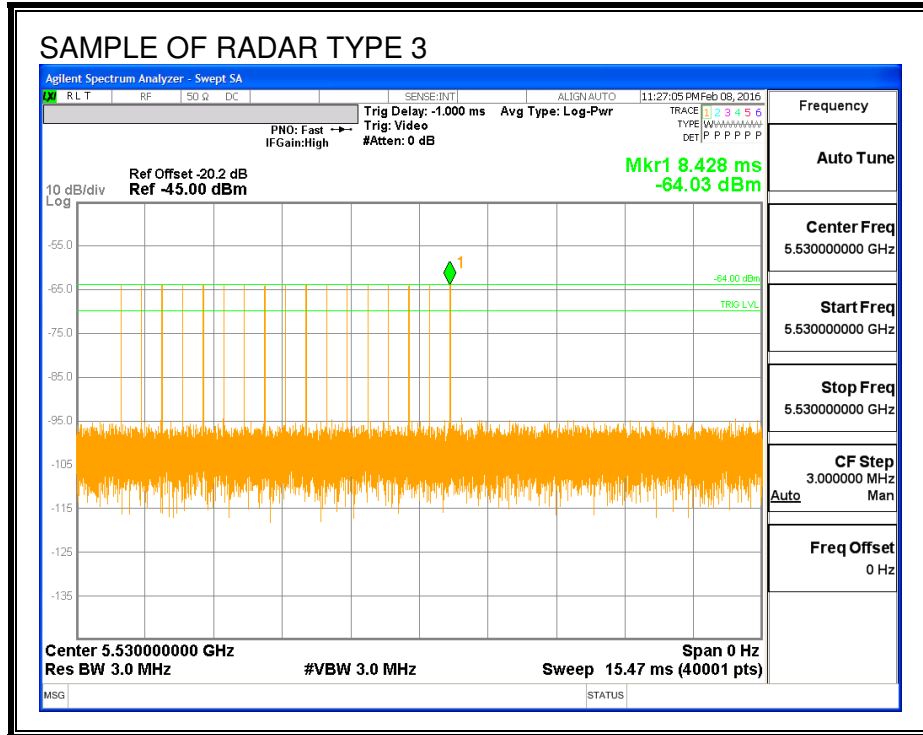

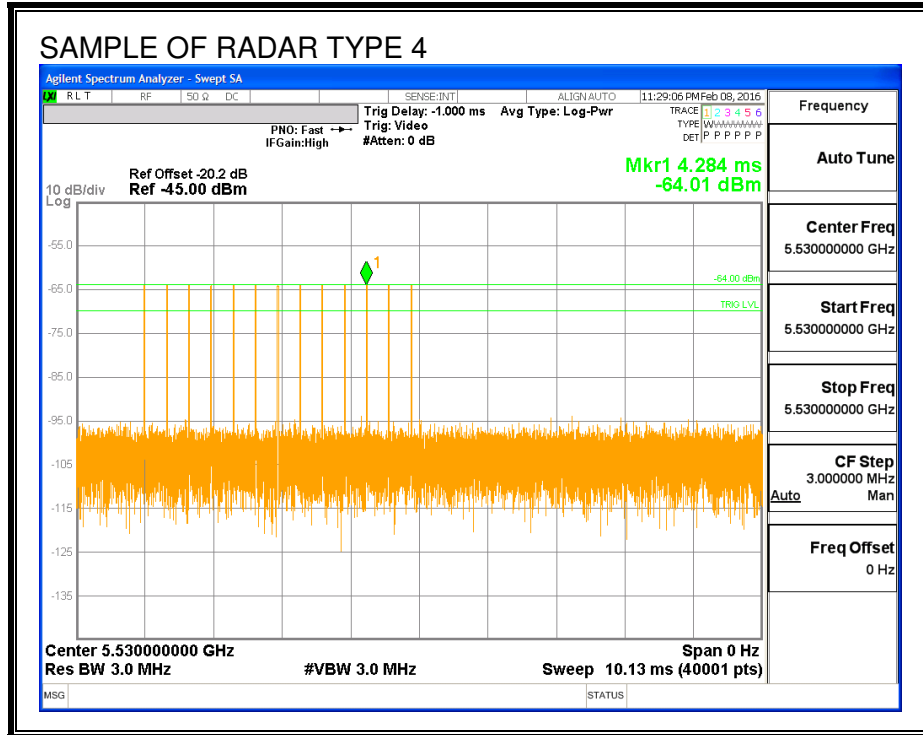

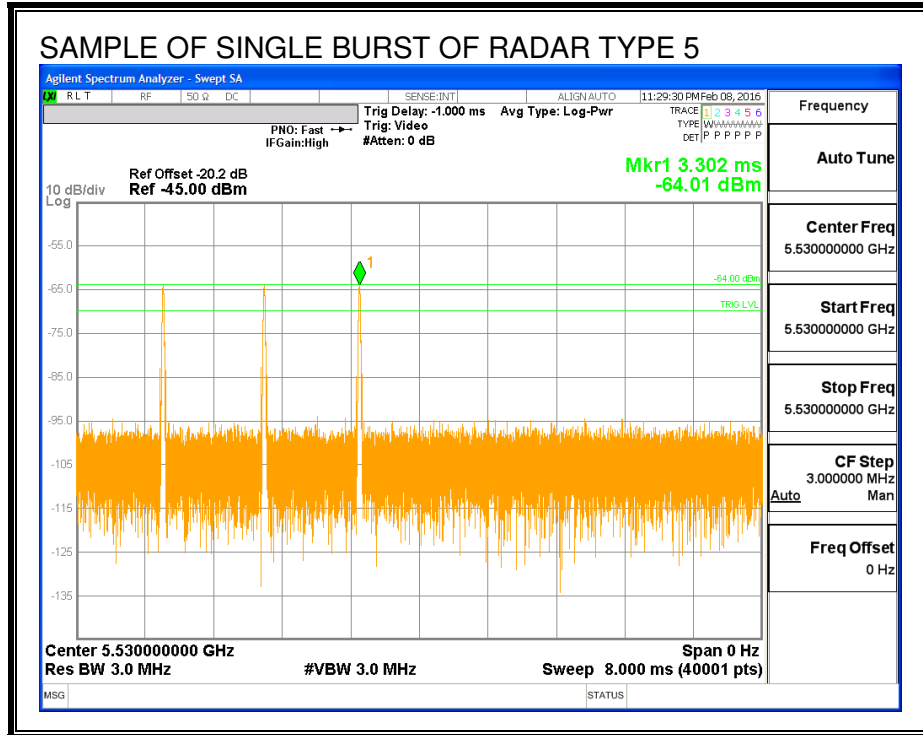

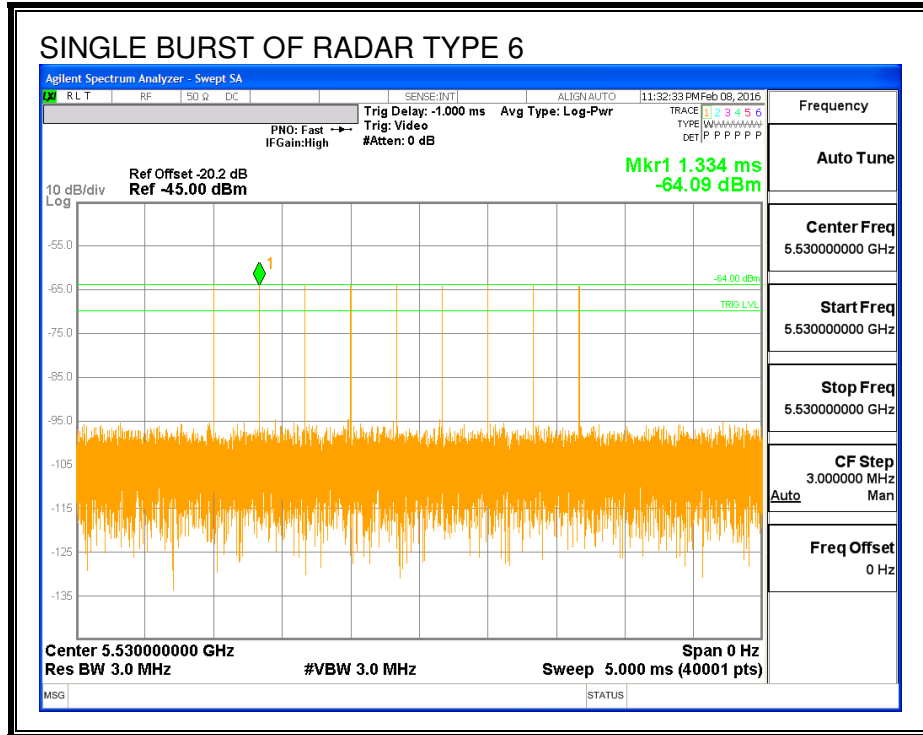

TRAFFIC

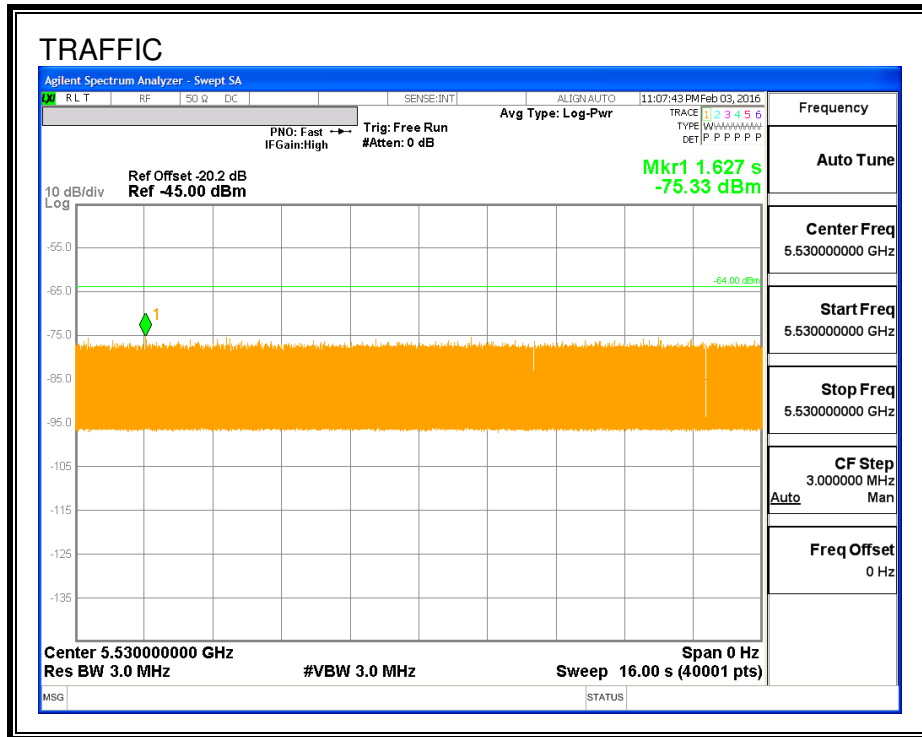

CHANNEL LOADING

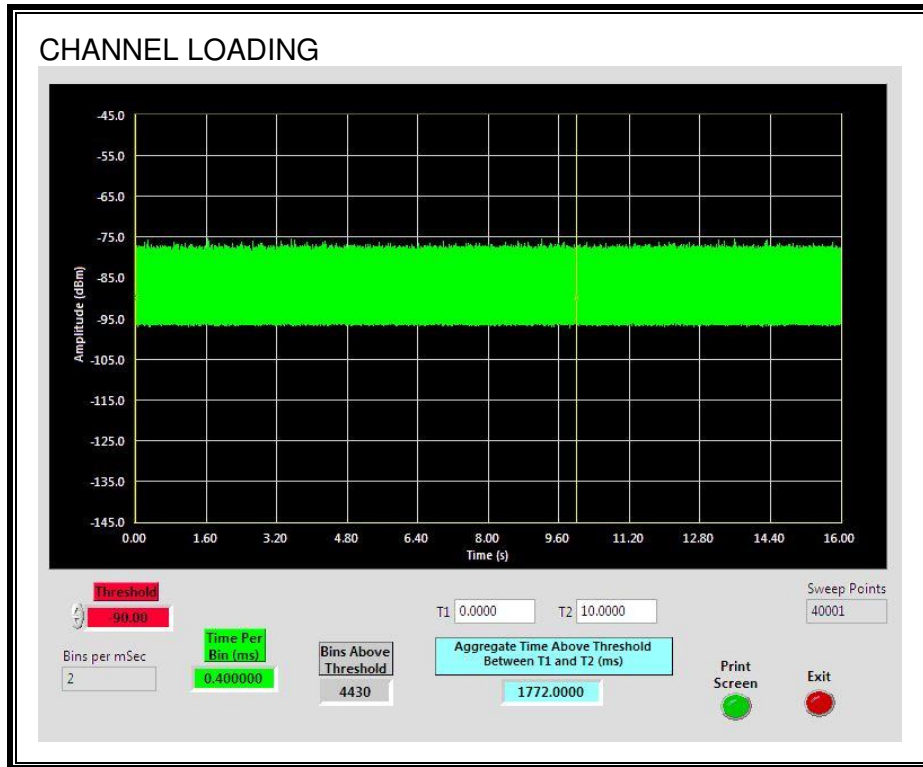

The level of traffic loading on the channel by the EUT is 17.72%.

5.4.1. CHANNEL AVAILABILITY CHECK TIME

PROCEDURE TO DETERMINE INITIAL POWER-UP CYCLE TIME

A link was established on channel then the EUT was rebooted. The time from the cessation of traffic to the re-initialization of traffic was measured as the time required for the EUT to complete the total power-up cycle. The time to complete the initial power-up period is 60 seconds less than this total power-up time.

PROCEDURE FOR TIMING OF RADAR BURST

With a link established on channel, the EUT was rebooted. A radar signal was triggered within 0 to 6 seconds after the initial power-up period, and transmissions on the channel were monitored on the spectrum analyzer.

The Non-Occupancy list was cleared. With a link established on channel, the EUT was rebooted. A radar signal was triggered within 54 to 60 seconds after the initial power-up period, and transmissions on the channel were monitored on the spectrum analyzer.

QUANTITATIVE RESULTS

No Radar Triggered

Timing of Reboot (sec)	Timing of Start of Traffic (sec)	Total Power-up Cycle Time (sec)	Initial Power-up Cycle Time (sec)
30.45	160.4	130.0	70.0

Radar Near Beginning of CAC

Timing of Reboot (sec)	Timing of Radar Burst (sec)	Radar Relative to Reboot (sec)	Radar Relative to Start of CAC (sec)
30.05	100.9	70.9	0.9

Radar Near End of CAC

Timing of Reboot (sec)	Timing of Radar Burst (sec)	Radar Relative to Reboot (sec)	Radar Relative to Start of CAC (sec)
30.3	159.2	128.9	59.0

QUALITATIVE RESULTS

Timing of Radar Burst	Display on Control Computer	Spectrum Analyzer Display
No Radar Triggered	EUT marks Channel as active	Transmissions begin on channel after completion of the initial power-up cycle and the CAC
Within 0 to 6 second window	EUT indicates radar detected	No transmissions on channel
Within 54 to 60 second window	EUT indicates radar detected	No transmissions on channel

TIMING WITHOUT RADAR DURING CAC

AP is rebooted
 Traffic ceases
 Start of Initial Power-up cycle

End of Initial Power-up cycle
 Start of CAC

End of CAC
 Traffic is Initiated

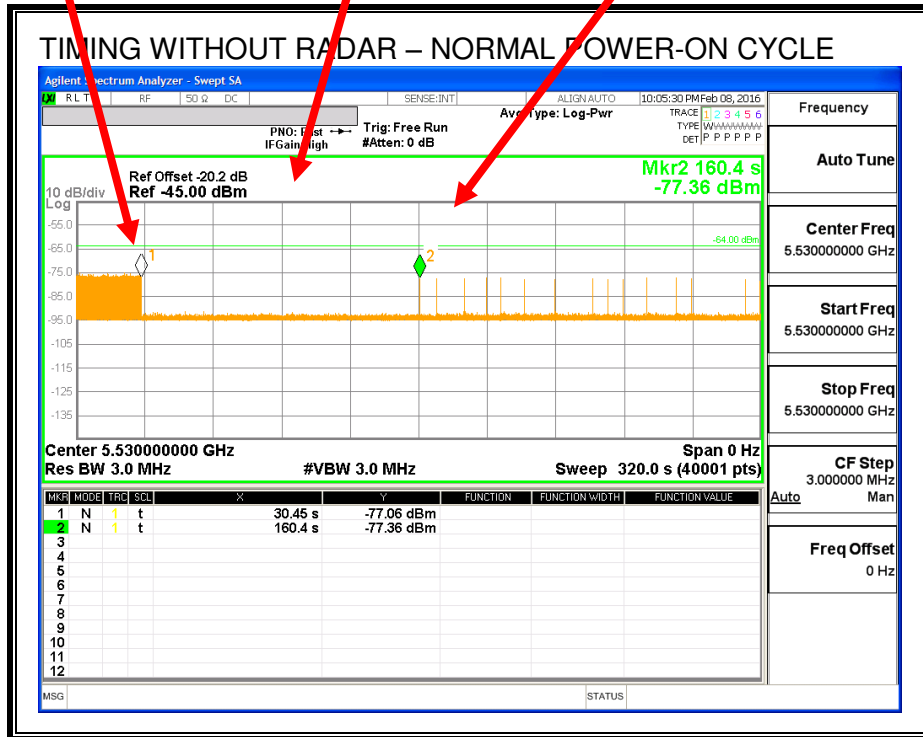

Transmissions begin on channel after completion of the initial power-up cycle and the CAC.

TIMING WITH RADAR NEAR BEGINNING OF CAC

AP is rebooted
 Traffic ceases
 Start of Initial Power-up cycle

End of Initial Power-up cycle
 Start of CAC

Radar Signal Applied

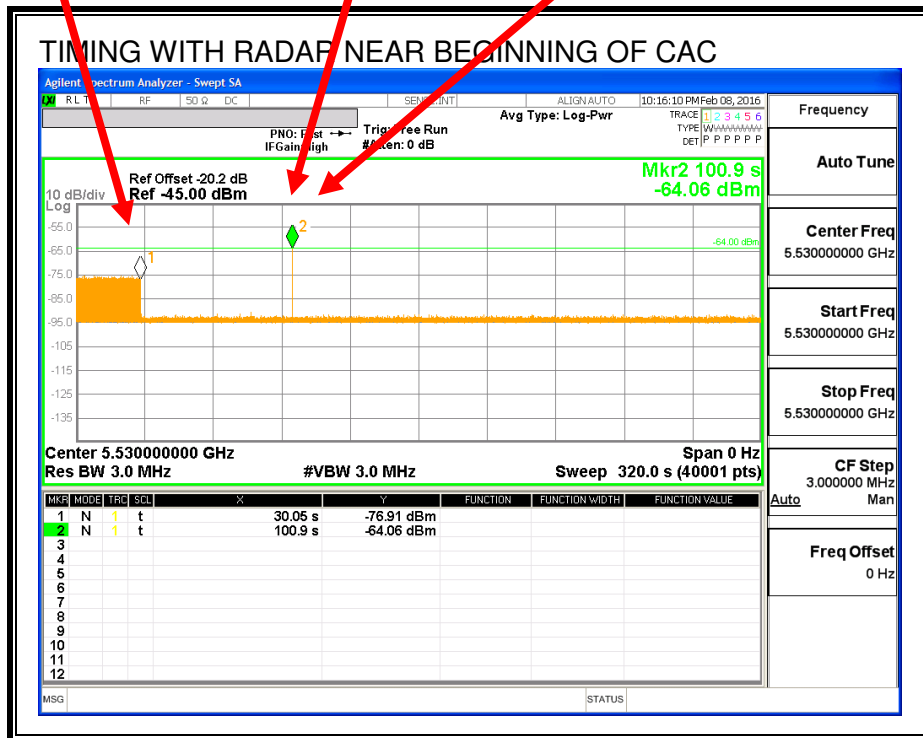

No EUT transmissions were observed after the radar signal.

TIMING WITH RADAR NEAR END OF CAC

AP is rebooted
 Traffic ceases
 Start of Initial Power-up cycle

End of Initial Power-up cycle
 Start of CAC

Radar Signal Applied

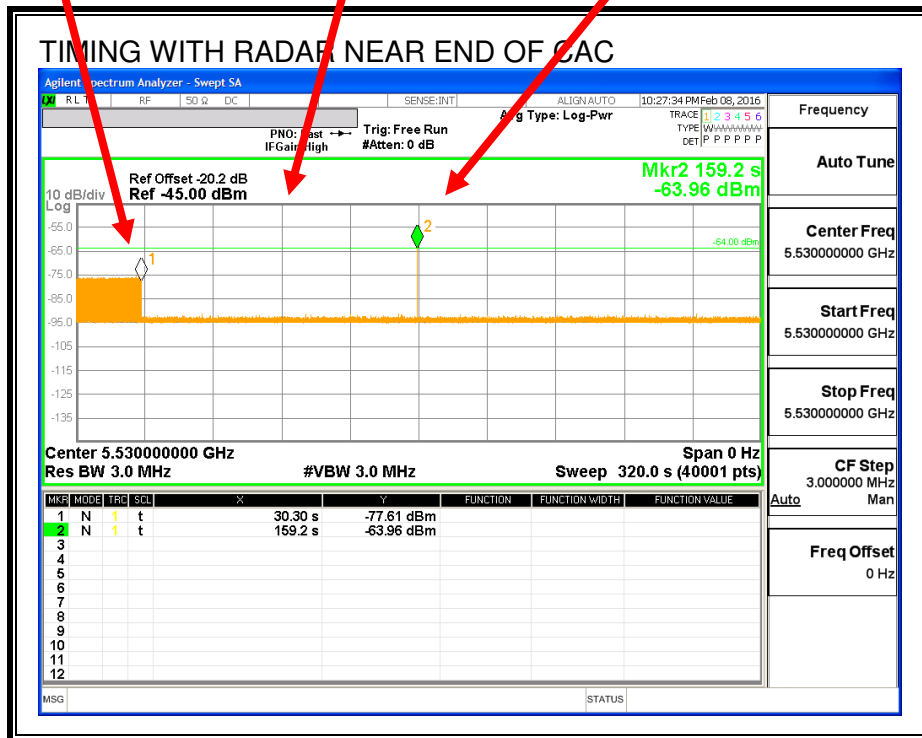

No EUT transmissions were observed after the radar signal.

5.4.2. OVERLAPPING CHANNEL TESTS

RESULTS

The channel spacing is not less than the channel bandwidth therefore the EUT does not have an overlapping channel plan.

These tests are not applicable.

5.4.3. MOVE AND CLOSING TIME

REPORTING NOTES

The reference marker is set at the end of last radar pulse.

The delta marker is set at the end of the last WLAN transmission following the radar pulse. This delta is the channel move time.

The aggregate channel closing transmission time is calculated as follows:

Aggregate Transmission Time =
(Number of analyzer bins showing transmission) * (dwell time per bin)

The observation period over which the aggregate time is calculated begins at (Reference Marker + 200 msec) and ends no earlier than (Reference Marker + 10 sec).

RESULTS

Channel Move Time (sec)	Limit (sec)
0.050	10

Aggregate Channel Closing Transmission Time (msec)	Limit (msec)
0.0	60

MOVE TIME

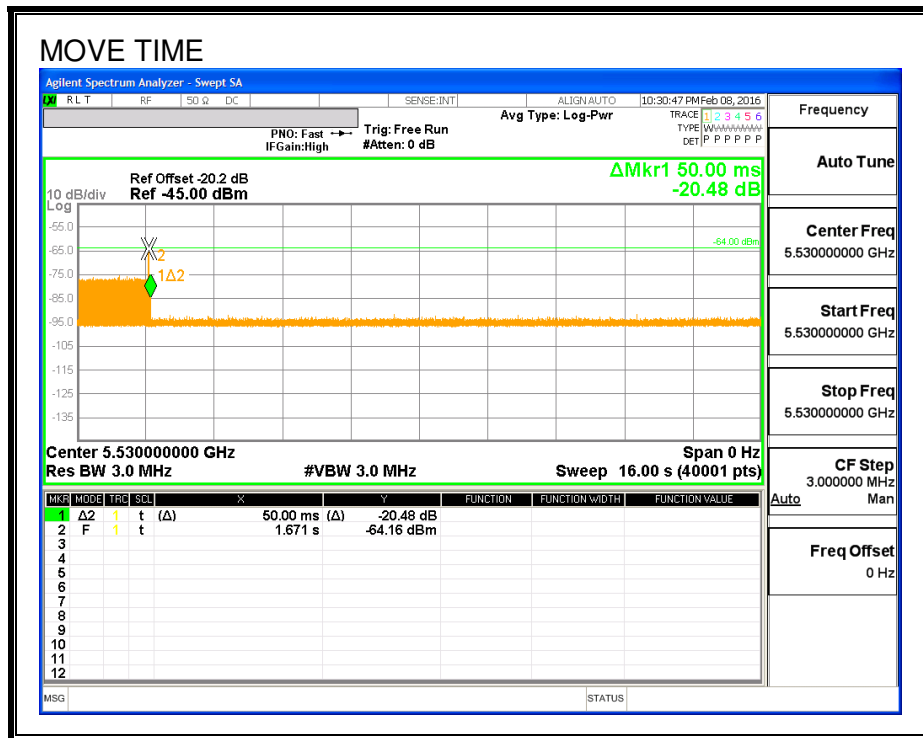

CHANNEL CLOSING TIME

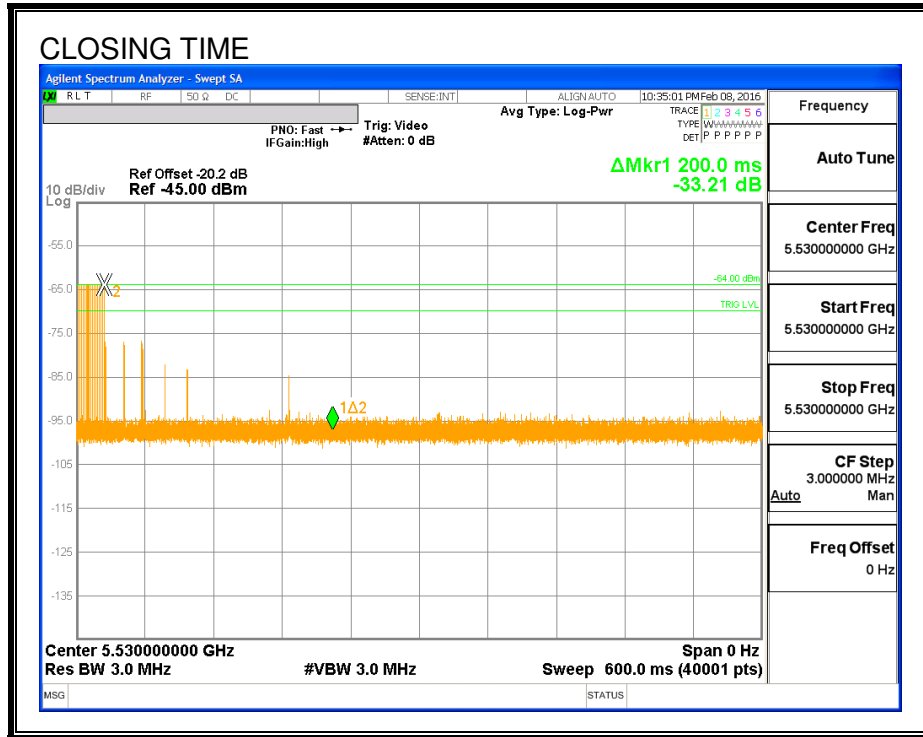

AGGREGATE CHANNEL CLOSING TRANSMISSION TIME

No transmissions are observed during the aggregate monitoring period.

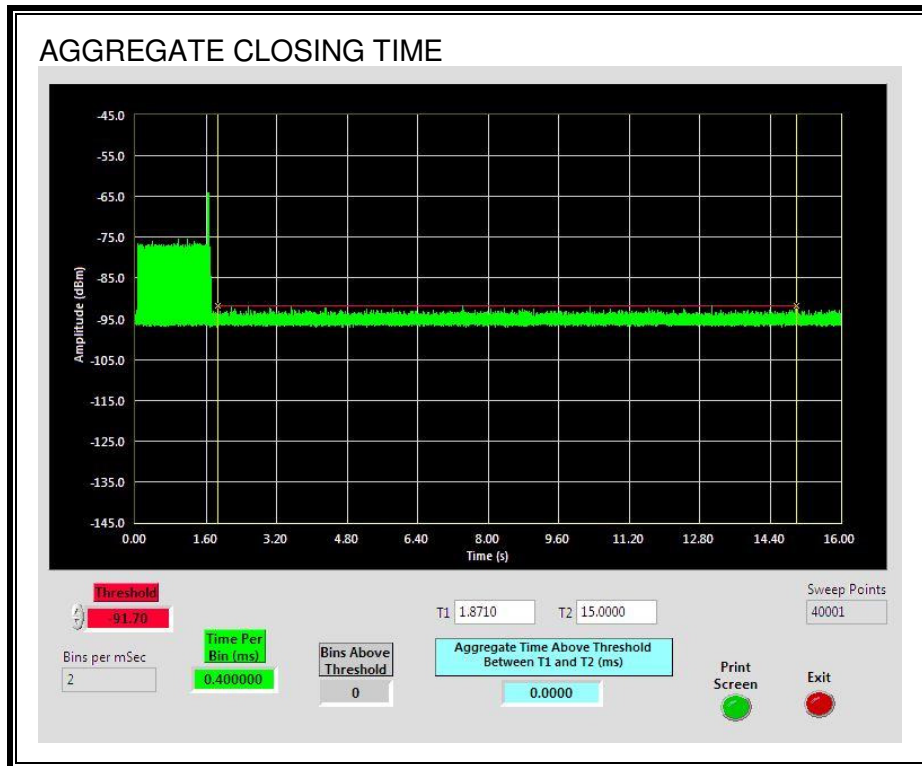

LONG PULSE CHANNEL MOVE TIME

The traffic ceases prior to 10 seconds after the end of the radar waveform.

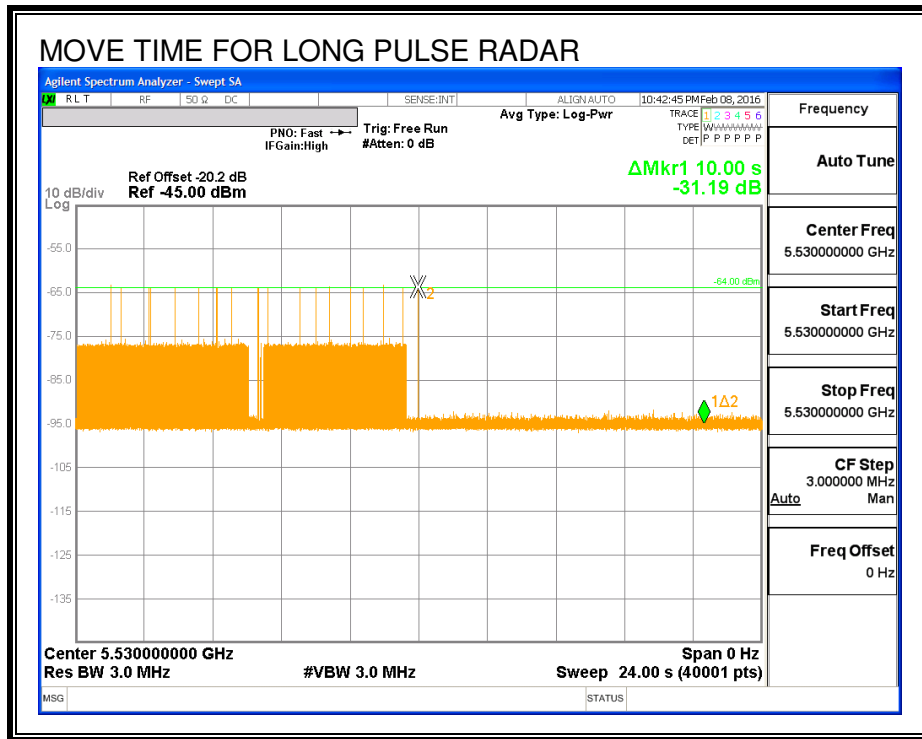

5.4.1. NON-OCCUPANCY PERIOD

RESULTS

No EUT transmissions were observed on the test channel during the 30-minute observation time.

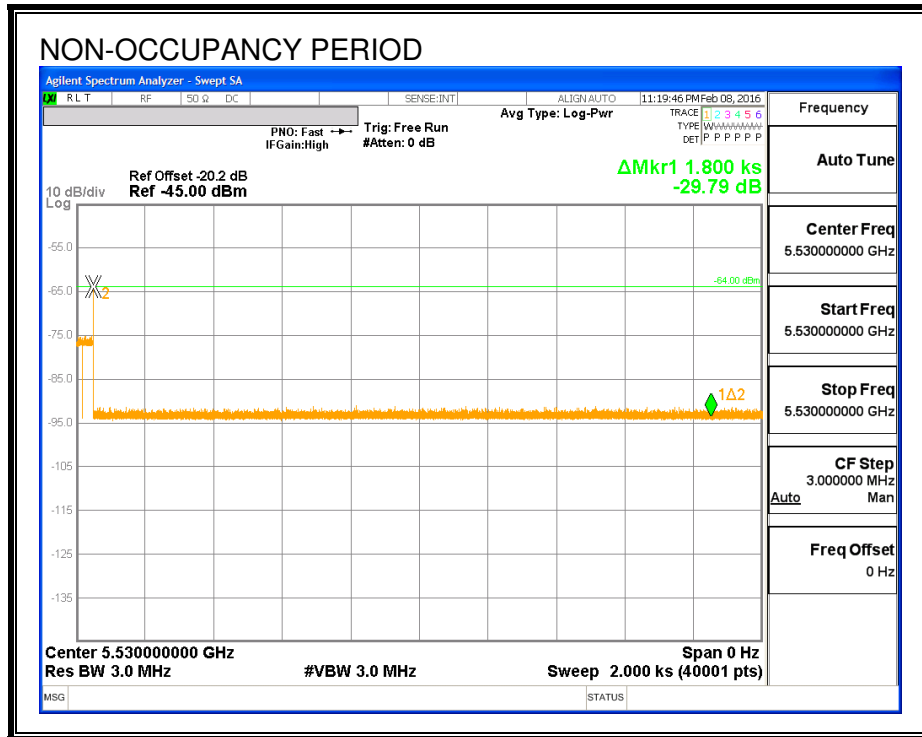

5.4.2. DETECTION BANDWIDTH

REFERENCE PLOT OF 99% POWER BANDWIDTH

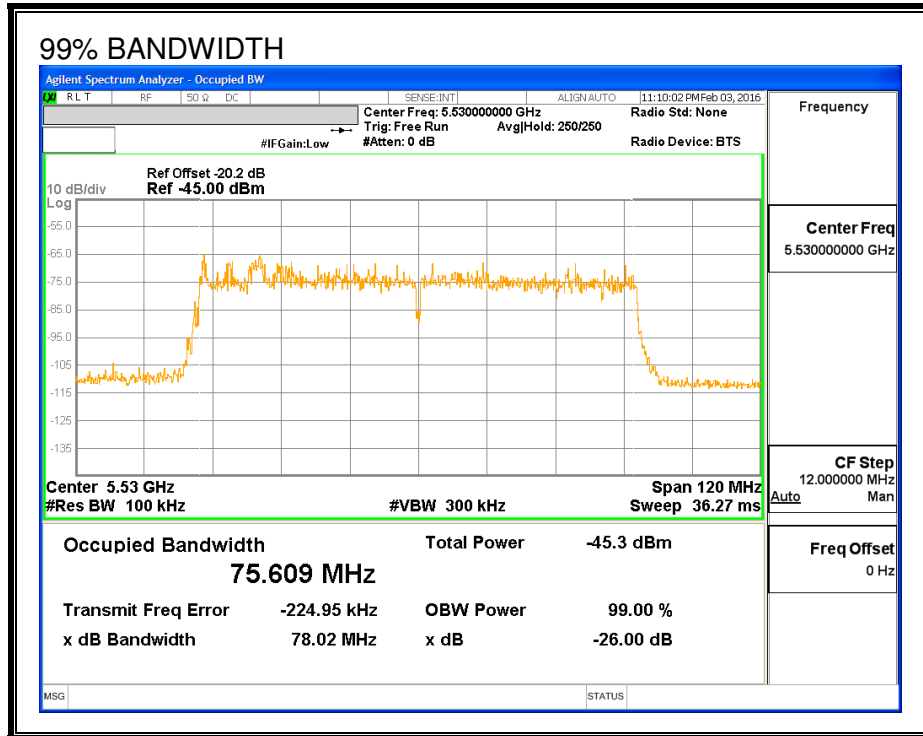

RESULTS

FL	FH	Detection Bandwidth	99% Power Bandwidth	Ratio of Detection BW to 99% Power BW	Minimum Limit
(MHz)	(MHz)	(MHz)	(MHz)	(%)	(%)
5491	5569	78	75.609	103.2	100

DETECTION BANDWIDTH PROBABILITY

DETECTION BANDWIDTH PROBABILITY RESULTS				
Detection Bandwidth Test Results				
FCC Type 0 Waveform: 1 us Pulse Width, 1428 us PRI, 18 Pulses per Burst				
Frequency (MHz)	Number of Trials	Number Detected	Detection (%)	Mark
5490	10	0	0	
5491	10	10	100	FL
5492	10	9	90	
5493	10	10	100	
5494	10	10	100	
5495	10	10	100	
5500	10	10	100	
5505	10	10	100	
5510	10	10	100	
5515	10	10	100	
5520	10	10	100	
5525	10	10	100	
5530	10	10	100	
5535	10	10	100	
5540	10	10	100	
5545	10	10	100	
5550	10	10	100	
5555	10	10	100	
5560	10	10	100	
5565	10	9	90	
5566	10	10	100	
5567	10	9	90	
5568	20	18	90	
5569	20	18	90	FH
5570	10	0	0	

5.4.3. IN-SERVICE MONITORING

RESULTS

FCC Radar Test Summary								
Signal Type	Number of Trials	Detection (%)	Limit (%)	Pass/Fail	Detection Bandwidth		80% of Det BW	
					FL	FH	FL5	FH5
FCC Short Pulse Type 1	30	86.67	60	Pass	5491	5569		
FCC Short Pulse Type 2	30	86.67	60	Pass	5491	5569		
FCC Short Pulse Type 3	30	96.67	60	Pass	5491	5569		
FCC Short Pulse Type 4	30	93.33	60	Pass	5491	5569		
Aggregate		90.83	80	Pass				
FCC Long Pulse Type 5	30	83.33	80	Pass	5491	5569	5499	5561
FCC Hopping Type 6	79	100.00	70	Pass	5491	5569		

TYPE 1 DETECTION PROBABILITY

Data Sheet for FCC Short Pulse Radar Type 1						
Waveform	Pulse Width (us)	PRI (us)	Pulses Per Burst	Test (A/B)	Frequency (MHz)	Successful Detection (Yes/No)
1001	1	3066	18	A	5530	No
1002	1	758	70	A	5530	Yes
1003	1	738	72	A	5530	Yes
1004	1	558	95	A	5530	Yes
1005	1	658	81	A	5530	Yes
1006	1	918	58	A	5530	Yes
1007	1	798	67	A	5530	Yes
1008	1	638	83	A	5530	Yes
1009	1	858	62	A	5530	Yes
1010	1	578	92	A	5530	Yes
1011	1	698	76	A	5530	Yes
1012	1	818	65	A	5530	Yes
1013	1	678	78	A	5530	No
1014	1	938	57	A	5530	Yes
1015	1	598	89	A	5530	Yes
1016	1	2711	20	B	5530	Yes
1017	1	925	58	B	5530	Yes
1018	1	2687	20	B	5530	Yes
1019	1	2384	23	B	5530	Yes
1020	1	534	99	B	5530	Yes
1021	1	1555	34	B	5530	Yes
1022	1	1187	45	B	5530	Yes
1023	1	1143	47	B	5530	Yes
1024	1	2099	26	B	5530	Yes
1025	1	990	54	B	5530	Yes
1026	1	881	60	B	5530	Yes
1027	1	2449	22	B	5530	No
1028	1	2470	22	B	5530	No
1029	1	2973	18	B	5530	Yes
1030	1	575	92	B	5530	Yes

TYPE 2 DETECTION PROBABILITY

Data Sheet for FCC Short Pulse Radar Type 2					
Waveform	Pulse Width (us)	PRI (us)	Pulses Per Burst	Frequency (MHz)	Successful Detection (Yes/No)
2001	4.9	175	27	5530	No
2002	3.1	217	28	5530	Yes
2003	3.9	211	28	5530	Yes
2004	2.3	220	26	5530	Yes
2005	1.5	218	23	5530	Yes
2006	2.3	150	29	5530	Yes
2007	3.5	195	29	5530	Yes
2008	2.6	213	25	5530	Yes
2009	2.2	224	29	5530	Yes
2010	3.4	164	26	5530	Yes
2011	1.2	179	23	5530	Yes
2012	4.8	167	24	5530	Yes
2013	2.9	186	25	5530	Yes
2014	2.6	178	29	5530	Yes
2015	4.9	163	28	5530	Yes
2016	2.9	159	25	5530	Yes
2017	3.6	230	24	5530	Yes
2018	1.8	192	26	5530	No
2019	2.6	229	29	5530	Yes
2020	1	195	24	5530	No
2021	4.3	155	27	5530	Yes
2022	1	206	27	5530	Yes
2023	4.4	170	23	5530	Yes
2024	1.3	187	23	5530	No
2025	5	198	27	5530	Yes
2026	4.3	220	23	5530	Yes
2027	4	154	24	5530	Yes
2028	3.5	222	28	5530	Yes
2029	1.6	161	23	5530	Yes
2030	1.3	152	27	5530	Yes

TYPE 3 DETECTION PROBABILITY

Data Sheet for FCC Short Pulse Radar Type 3					
Waveform	Pulse Width (us)	PRI (us)	Pulses Per Burst	Frequency (MHz)	Successful Detection (Yes/No)
3001	5.9	464	17	5530	Yes
3002	5.8	451	16	5530	Yes
3003	6.6	419	18	5530	Yes
3004	9.4	301	18	5530	Yes
3005	5.4	415	17	5530	Yes
3006	6.1	310	18	5530	Yes
3007	7.5	437	17	5530	Yes
3008	8.4	344	16	5530	Yes
3009	7.7	484	18	5530	Yes
3010	8.9	420	18	5530	Yes
3011	8.4	321	16	5530	Yes
3012	7.4	387	18	5530	Yes
3013	7.2	434	18	5530	Yes
3014	6.5	396	17	5530	Yes
3015	9.2	456	18	5530	Yes
3016	8.8	430	17	5530	Yes
3017	9.4	385	16	5530	Yes
3018	9.3	254	16	5530	No
3019	5	473	17	5530	Yes
3020	7.8	424	16	5530	Yes
3021	7.9	287	16	5530	Yes
3022	8.6	433	17	5530	Yes
3023	10	309	18	5530	Yes
3024	5.8	467	18	5530	Yes
3025	5.1	489	16	5530	Yes
3026	6.3	292	16	5530	Yes
3027	5.8	444	18	5530	Yes
3028	9.9	392	16	5530	Yes
3029	9.7	306	17	5530	Yes
3030	9	268	16	5530	Yes

TYPE 4 DETECTION PROBABILITY

Data Sheet for FCC Short Pulse Radar Type 4					
Waveform	Pulse Width (us)	PRI (us)	Pulses Per Burst	Frequency (MHz)	Successful Detection (Yes/No)
4001	13.3	328	13	5530	Yes
4002	17.9	435	16	5530	Yes
4003	13.6	257	15	5530	Yes
4004	18.7	377	16	5530	Yes
4005	15	345	15	5530	Yes
4006	10.5	478	16	5530	Yes
4007	12.7	459	15	5530	Yes
4008	14.1	354	15	5530	Yes
4009	16.7	480	14	5530	Yes
4010	18.6	270	14	5530	Yes
4011	17.1	410	16	5530	Yes
4012	19.5	463	16	5530	Yes
4013	18.5	364	16	5530	Yes
4014	16.6	313	16	5530	Yes
4015	16.1	478	12	5530	Yes
4016	14.8	439	15	5530	Yes
4017	10.1	382	16	5530	Yes
4018	14.7	356	12	5530	Yes
4019	10.4	429	13	5530	Yes
4020	15.5	298	14	5530	No
4021	11.8	266	13	5530	Yes
4022	17.4	399	14	5530	Yes
4023	14.8	379	14	5530	Yes
4024	10.9	274	13	5530	Yes
4025	13.5	401	13	5530	Yes
4026	15.4	442	12	5530	Yes
4027	13.9	330	15	5530	Yes
4028	16.3	384	14	5530	Yes
4029	15.3	285	15	5530	No
4030	13.5	485	15	5530	Yes

TYPE 5 DETECTION PROBABILITY

Data Sheet for FCC Long Pulse Radar Type 5		
Trial	Frequency (MHz)	Successful Detection (Yes/No)
1	5531	Yes
2	5547	No
3	5532	Yes
4	5514	Yes
5	5523	Yes
6	5553	Yes
7	5557	Yes
8	5559	No
9	5558	Yes
10	5518	Yes
11	5543	Yes
12	5500	Yes
13	5547	Yes
14	5512	Yes
15	5525	Yes
16	5532	Yes
17	5549	Yes
18	5545	Yes
19	5529	Yes
20	5505	Yes
21	5511	Yes
22	5518	Yes
23	5505	Yes
24	5553	Yes
25	5514	Yes
26	5548	Yes
27	5530	No
28	5539	No
29	5523	No
30	5508	Yes

Note: The Type 5 randomized parameters tested are shown in a separate document.

TYPE 6 DETECTION PROBABILITY

Data Sheet for FCC Hopping Radar Type 6				
1 us Pulse Width, 333 us PRI, 9 Pulses per Burst, 1 Burst per Hop				
NTIA August 2005 Hopping Sequence				
Trial	Starting Index Within Sequence	Signal Generator Frequency (MHz)	Hops within Detection BW	Successful Detection (Yes/No)
1	338	5491	9	Yes
2	813	5492	15	Yes
3	1288	5493	20	Yes
4	1763	5494	21	Yes
5	2238	5495	21	Yes
6	2713	5496	12	Yes
7	3188	5497	13	Yes
8	3663	5498	11	Yes
9	4138	5499	16	Yes
10	4613	5500	14	Yes
11	5088	5501	12	Yes
12	5563	5502	13	Yes
13	6038	5503	11	Yes
14	6513	5504	16	Yes
15	6988	5505	16	Yes
16	7463	5506	13	Yes
17	7938	5507	14	Yes
18	8413	5508	18	Yes
19	8888	5509	24	Yes
20	9363	5510	14	Yes
21	9838	5511	15	Yes
22	10313	5512	19	Yes
23	10788	5513	20	Yes
24	11263	5514	18	Yes
25	11738	5515	11	Yes
26	12213	5516	14	Yes
27	12688	5517	25	Yes
28	13163	5518	15	Yes
29	13638	5519	13	Yes
30	14113	5520	19	Yes
31	14588	5521	12	Yes
32	15063	5522	14	Yes
33	15538	5523	15	Yes
34	16013	5524	17	Yes
35	16488	5525	18	Yes
36	16963	5526	14	Yes
37	17438	5527	12	Yes
38	17913	5528	14	Yes

TYPE 6 DETECTION PROBABILITY (CONTINUED)

39	18388	5529	14	Yes
40	18863	5530	19	Yes
41	19338	5531	22	Yes
42	19813	5532	16	Yes
43	20288	5533	15	Yes
44	20763	5534	11	Yes
45	21238	5535	23	Yes
46	21713	5536	16	Yes
47	22188	5537	10	Yes
48	22663	5538	15	Yes
49	23138	5539	11	Yes
50	23613	5540	15	Yes
51	24088	5541	13	Yes
52	24563	5542	14	Yes
53	25038	5543	17	Yes
54	25513	5544	17	Yes
55	25988	5545	14	Yes
56	26463	5546	16	Yes
57	26938	5547	15	Yes
58	27413	5548	21	Yes
59	27888	5549	18	Yes
60	28363	5550	17	Yes
61	28838	5551	19	Yes
62	29313	5552	19	Yes
63	29788	5553	13	Yes
64	30263	5554	14	Yes
65	30738	5555	15	Yes
66	31213	5556	18	Yes
67	31688	5557	13	Yes
68	32163	5558	20	Yes
69	32638	5559	21	Yes
70	33113	5560	19	Yes
71	33588	5561	20	Yes
72	34063	5562	22	Yes
73	34538	5563	17	Yes
74	35013	5564	25	Yes
75	35488	5565	18	Yes
76	35963	5566	23	Yes
77	36438	5567	17	Yes
78	36913	5568	17	Yes
79	37388	5569	16	Yes

6. BRIDGE MODE RESULTS

Per KDB 905462, Section 5.1 (footnote 1):

Networks Access Points with Bridge and/or MESH modes of operation are permitted to operate in the DFS bands but must employ a DFS function. The functionality of the Bridge mode as specified in §15.403(a) must be validated in the DFS test report. Devices operating as relays must also employ DFS function. The method used to validate the functionality must be documented and validation data must be documented. Bridge mode can be validated by performing a test statistical performance check (Section 7.8.4) on any one of the radar types. This is an abbreviated test to verify DFS functionality. MESH mode operational methodology must be submitted in the application for certification for evaluation by the FCC.

This device does not support Bridge Mode, therefore this test was not performed.