



# RADIO TEST REPORT

**FCC ID** : UDX-600200010  
**Equipment** : Cisco Wireless 9178I Series Wi-Fi 7 Access Point  
**Brand Name** : CISCO  
**Model Name** : CW9178I  
**Applicant** : Cisco Systems, Inc.  
170 West Tasman Drive, San Jose, CA 95134 USA  
**Manufacturer** : Cisco Systems, Inc.  
170 West Tasman Drive, San Jose, CA 95134 USA  
**Standard** : 47 CFR FCC Part 15.247

The product was received on Jan. 17, 2024, and testing was started from Feb. 21, 2024 and completed on Jun. 11, 2024. We, Sporton International Inc. Hsinchu Laboratory, would like to declare that the tested sample has been evaluated in accordance with the procedures given in ANSI C63.10-2013 and shown compliance with the applicable technical standards.

The test results in this report apply exclusively to the tested model / sample. Without written approval of Sporton International Inc. Hsinchu Laboratory, the test report shall not be reproduced except in full.

Approved by: Rex Liao

**Sporton International Inc. Hsinchu Laboratory**

No.8, Ln. 724, Bo'ai St., Zhubei City, Hsinchu County 302010, Taiwan (R.O.C.)



## Table of Contents

**History of this test report.....3**

**Summary of Test Result.....4**

**1 General Description .....5**

1.1 Information.....5

1.2 Applicable Standards .....13

1.3 Testing Location Information .....13

1.4 Measurement Uncertainty .....14

**2 Test Configuration of EUT .....15**

2.1 Test Channel Mode .....15

2.2 The Worst Case Measurement Configuration .....16

2.3 EUT Operation during Test .....18

2.4 Accessories .....18

2.5 Support Equipment.....19

2.6 Test Setup Diagram .....20

**3 Transmitter Test Result .....23**

3.1 AC Power-line Conducted Emissions .....23

3.2 DTS Bandwidth.....25

3.3 Maximum Conducted Output Power .....26

3.4 Power Spectral Density .....29

3.5 Emissions in Non-restricted Frequency Bands .....31

3.6 Emissions in Restricted Frequency Bands.....32

**4 Test Equipment and Calibration Data .....36**

**Appendix A. Test Results of AC Power-line Conducted Emissions**

**Appendix B. Test Results of DTS Bandwidth**

**Appendix C. Test Results of Maximum Conducted Output Power**

**Appendix D. Test Results of Power Spectral Density**

**Appendix E. Test Results of Emissions in Non-restricted Frequency Bands**

**Appendix F. Test Results of Emissions in Restricted Frequency Bands**

**Appendix G. Test Photos**

### Photographs of EUT v01





### Summary of Test Result

Report Clause	Ref Std. Clause	Test Items	Result (PASS/FAIL)	Remark
1.1.2	15.203	Antenna Requirement	PASS	-
3.1	15.207	AC Power-line Conducted Emissions	PASS	-
3.2	15.247(a)	DTS Bandwidth	PASS	-
3.3	15.247(b)	Maximum Conducted Output Power	PASS	-
3.4	15.247(e)	Power Spectral Density	PASS	-
3.5	15.247(d)	Emissions in Non-restricted Frequency Bands	PASS	-
3.6	15.247(d)	Emissions in Restricted Frequency Bands	PASS	-

**Conformity Assessment Condition:**

1. The test results (PASS/FAIL) with all measurement uncertainty excluded are presented against the regulation limits or in accordance with the requirements stipulated by the applicant/manufacture who shall bear all the risks of non-compliance that may potentially occur if measurement uncertainty is taken into account.
2. The measurement uncertainty please refer to each test result in the chapter "Measurement Uncertainty".

**Disclaimer:**

The product specifications of the EUT presented in the test report that may affect the test assessments are declared by the manufacturer who shall take full responsibility for the authenticity.

Reviewed by: **Sam Chen**  
Report Producer: **Cathy Chiu**



# 1 General Description

## 1.1 Information

### 1.1.1 RF General Information

Frequency Range (MHz)	Bluetooth Mode	Ch. Frequency (MHz)	Channel Number
2400-2483.5	LE	2402-2480	0-39 [40]

Band	Mode	BWch (MHz)	Nant
2400-2483.5	BT-LE(1Mbps)	1	1TX/1RX
2400-2483.5	BT-LE(500Kb/s)	1	1TX/1RX
2400-2483.5	BT-LE(125Kb/s)	1	1TX/1RX
2400-2483.5	BT-LE(2Mbps)	2	1TX/1RX

Note:

- ◆ Bluetooth LE uses a GFSK modulation.
- ◆ BWch is the nominal channel bandwidth.

**1.1.2 Antenna Information**

Ant.	Brand Name	Model Name	Antenna Type	Connector	Support Function	Gain (dBi)
1	WNC	95XEAK15.G98	PIFA	I-PEX	Radio 1 2.4GHz and Radio 2 5GHz UNII 1~2A	Note2
2	WNC	95XEAK15.G96	PCB	I-PEX	Radio 1 2.4GHz and Radio 2 5GHz UNII 1~2A	
3	WNC	95XEAK15.G97	PCB	I-PEX	Radio 1 2.4GHz and Radio 2 5GHz UNII 1~2A	
4	WNC	95XEAK15.G99	PIFA	I-PEX	Radio 1 2.4GHz and Radio 2 5GHz UNII 1~2A	
5	WNC	95XEAK15.GA3	PIFA	I-PEX	Radio 3 5GHz UNII 1~3	
6	WNC	95XEAK15.GA1	PCB	I-PEX	Radio 3 5GHz UNII 1~3	
7	WNC	95XEAK15.GA2	PCB	I-PEX	Radio 3 5GHz UNII 1~3	
8	WNC	95XEAK15.GA4	PIFA	I-PEX	Radio 3 5GHz UNII 1~3	
9	WNC	95XEAK15.GA7	PIFA	I-PEX	Radio 4 6GHz UNII 5~8	
10	WNC	95XEAK15.GA5	PCB	I-PEX	Radio 4 6GHz UNII 5~8	
11	WNC	95XEAK15.GA6	PCB	I-PEX	Radio 4 6GHz UNII 5~8	
12	WNC	95XEAK15.GA8	PIFA	I-PEX	Radio 4 6GHz UNII 5~8	
13	WNC	95XEAK15.GAB	PIFA	I-PEX	Radio 5 2.4GHz, 5GHz UNII 1~3 and 6GHz UNII 5~8	
14	WNC	95XEAK15.GAC	PIFA	I-PEX	Radio 5 2.4GHz, 5GHz UNII 1~3 and 6GHz UNII 5~8	
15	WNC	95XEAK15.GA9	PIFA	I-PEX	Radio 6 Bluetooth and Zigbee	
16	WNC	95XEAK15.GBM	PIFA	I-PEX	Radio 7 UWB	
17	WNC	95XEAK15.GBD	PCB	I-PEX	Radio 7 UWB	
18	WNC	95XEAK15.GAA	PIFA	I-PEX	Radio 8 GPS	



Ant.	Port															
	R1: WLAN 2.4GHz			R2: WLAN 5GHz UNII 1~2A			R3: WLAN 5GHz UNII 1~3			R4: WLAN 6GHz UNII 5~8			R5: WLAN 2.4GHz, WLAN 5GHz UNII 1~3, WLAN 6GHz UNII 5~8	R6: Bluetooth /Zigbee	R7: UWB	R8: GPS
	1TX	2TX	4TX	1TX	2TX	4TX	1TX	2TX	4TX	1TX	2TX	4TX	1TX	1TX	2TX	1RX
1	1	1	1	1	1	1	-	-	-	-	-	-	-	-	-	-
2	-	-	4	-	-	4	-	-	-	-	-	-	-	-	-	-
3	-	2	2	-	2	2	-	-	-	-	-	-	-	-	-	-
4	-	-	3	-	-	3	-	-	-	-	-	-	-	-	-	-
5	-	-	-	-	-	-	-	2	2	-	-	-	-	-	-	-
6	-	-	-	-	-	-	1	1	1	-	-	-	-	-	-	-
7	-	-	-	-	-	-	-	-	3	-	-	-	-	-	-	-
8	-	-	-	-	-	-	-	-	4	-	-	-	-	-	-	-
9	-	-	-	-	-	-	-	-	-	-	-	4	-	-	-	-
10	-	-	-	-	-	-	-	-	-	-	-	3	-	-	-	-
11	-	-	-	-	-	-	-	-	-	1	1	1	-	-	-	-
12	-	-	-	-	-	-	-	-	-	-	2	2	-	-	-	-
13	-	-	-	-	-	-	-	-	-	-	-	-	1	-	-	-
14	-	-	-	-	-	-	-	-	-	-	-	-	2	-	-	-
15	-	-	-	-	-	-	-	-	-	-	-	-	-	1	-	-
16	-	-	-	-	-	-	-	-	-	-	-	-	-	-	1	-
17	-	-	-	-	-	-	-	-	-	-	-	-	-	-	2	-
	-	-	-	-	-	-	-	-	-	-	-	-	-	-	3	-
	-	-	-	-	-	-	-	-	-	-	-	-	-	-	4	-
18	-	-	-	-	-	-	-	-	-	-	-	-	-	-	-	1

Note 1: R means Radio.



Note 2:

Ant.	Antenna Gain (dBi)								
	R1: WLAN 2.4GHz			R2: WLAN 5GHz UNII 1~2A					
				5.2G			5.3G		
1	2.85			3.51				3.24	
2	3.82			3.53				2.9	
3	3.85			3.93				3.85	
4	2.41			4.97				3.73	
Ant.	R3: WLAN 5GHz UNII 1~3								
	5.2G			5.3G			5.6G		5.785G
5	3.19			2.63			3.54		3.53
6	4.83			3.89			4.03		3.86
7	4.73			3.86			4.54		3.48
8	3.64			2.51			3.91		3.45
Ant.	R4: WLAN 6GHz UNII 5~8								
	6.175G			6.475G			6.695G		6.995G
9	4.69			3.74			4.57		5.38
10	4.68			5.42			5.56		4.3
11	4.77			4.82			4.67		4.42
12	4.7			2.33			3.23		3.98
Ant.	R5: WLAN 2.4GHz/5GHz UNII 1~3/WLAN 6GHz UNII 5~8								
	2.45G	5.2G	5.3G	5.6G	5.785G	6.175G	6.475G	6.695G	6.995G
13	2.17	2.74	3.39	4.78	3.51	3.96	4.67	4.31	4.8
14	1.83	5.46	4.17	6.68	6.06	5.1	4.49	4.37	4.7
Ant.	R6: Bluetooth/Zigbee								
	2.91								
15									
Ant.	R7: UWB								
	6.3								
16									
17	6.5								
Ant.	R8: GPS								
	1.16GHz~1.19GHz					1.56GHz~1.59GHz			
18	2.3					4.9			

Note 3:

Item	Directional Gain (dBi)								
	R1: WLAN 2.4GHz			R2: WLAN 5GHz UNII 1~2A					
				5.2G			5.3G		
2T1S	4.47			3.93				3.85	
2T2S	3.85			3.93				3.85	
4T1S	7.01			5.11				4.06	
4T2S	4.01			4.97				3.85	
4T4S	3.85			4.97				3.85	
Item	R3: WLAN 5GHz UNII 1~3 / R4: WLAN 6GHz UNII 5~8								
	5.2G	5.3G	5.6G	5.785G	6.175G	6.475G	6.695G	6.995G	
2T1S	4.83	3.89	4.03	3.86	4.97	4.82	4.67	4.42	
2T2S	4.83	3.89	4.03	3.86	4.77	4.82	4.67	4.42	
4T1S	6.96	5.69	6.34	5.28	6.14	6.09	6.02	5.46	
4T2S	4.83	3.89	4.54	3.86	4.77	5.42	5.56	5.38	
4T4S	4.83	3.89	4.54	3.86	4.77	5.42	5.56	5.38	

Note 4: The above information (excepting antenna gain of Radio 1~6) was declared by manufacturer.

Note 5: Radio 1~5: Maximum Directional Gain following KDB662911 D03.

**For WLAN 2.4GHz function (Radio 1):**

**For IEEE 802.11b/g/n/VHT/ax/be mode (1TX,2TX,4TX/4RX):**

For 1TX

Only Port 1 can be use as transmitting antenna.

For 2TX

Only Port 1 and Port 2 can be use as transmitting antenna.

Port 1 and Port 2 could transmit simultaneously.

For 4TX

Port 1, Port 2, Port 3 and Port 4 can be use as transmitting antenna.

Port 1, Port 2, Port 3 and Port 4 could transmit simultaneously.





For 4RX

Port 1, Port 2, Port 3 and Port 4 can be used as receiving antennas.

Port 1, Port 2, Port 3 and Port 4 could receive simultaneously.

**For WLAN 5GHz UNII 1~2A function (Radio 2):**

**For IEEE 802.11a/n/ac/ax/be mode (1TX,2TX,4TX/4RX):**

For 1TX

Only Port 1 can be use as transmitting antenna.

For 2TX

Only Port 1 and Port 2 can be use as transmitting antenna.

Port 1 and Port 2 could transmit simultaneously.

For 4TX

Port 1, Port 2, Port 3 and Port 4 can be use as transmitting antenna.

Port 1, Port 2, Port 3 and Port 4 could transmit simultaneously.

For 4RX

Port 1, Port 2, Port 3 and Port 4 can be used as receiving antennas.

Port 1, Port 2, Port 3 and Port 4 could receive simultaneously.

**For WLAN 5GHz UNII 1~3 function (Radio 3):**

**For IEEE 802.11a/n/ac/ax/be mode (1TX,2TX,4TX/4RX)**

For 1TX

Only Port 1 can be use as transmitting antenna.

For 2TX

Only Port 1 and Port 2 can be use as transmitting antenna.

Port 1 and Port 2 could transmit simultaneously.

For 4TX

Port 1, Port 2, Port 3 and Port 4 can be use as transmitting antenna.

Port 1, Port 2, Port 3 and Port 4 could transmit simultaneously.

For 4RX

Port 1, Port 2, Port 3 and Port 4 can be used as receiving antennas.

Port 1, Port 2, Port 3 and Port 4 could receive simultaneously.

**For WLAN 6GHz UNII 5~8 function (Radio 4):**

**For IEEE 802.11ax/be mode (1TX,2TX,4TX/4RX)**

For 1TX

Only Port 1 can be use as transmitting antenna.

For 2TX

Only Port 1 and Port 2 can be use as transmitting antenna.

Port 1 and Port 2 could transmit simultaneously.

For 4TX

Port 1, Port 2, Port 3 and Port 4 can be use as transmitting antenna.

Port 1, Port 2, Port 3 and Port 4 could transmit simultaneously.

For 4RX

Port 1, Port 2, Port 3 and Port 4 can be used as receiving antennas.

Port 1, Port 2, Port 3 and Port 4 could receive simultaneously.

**For Scanning Radio 5:**

**For WLAN 2.4GHz function:**

**For IEEE 802.11b/g/n/VHT/ax mode (1TX/2RX):**

For 1TX

Only Port 1 can be use as transmitting antenna.

For 2RX

Port 1 and Port 2 can be used as receiving antennas.

Port 1 and Port 2 could receive simultaneously.

**For WLAN 5GHz UNII 1~3 function:**

**For IEEE 802.11a/n/ac/ax mode (1TX/2RX):**

For 1TX



Only Port 1 can be use as transmitting antenna.

For 2RX

Port 1 and Port 2 can be used as receiving antennas.

Port 1 and Port 2 could receive simultaneously.

**For WLAN 6GHz UNII 5~8:**

**For IEEE 802.11ax mode (1TX/2RX):**

For 1TX

Only Port 1 can be use as transmitting antenna.

For 2RX

Port 1 and Port 2 can be used as receiving antennas.

Port 1 and Port 2 could receive simultaneously.

**For Bluetooth/Zigbee function (Radio 6):**

**For Bluetooth/Zigbee mode (1TX/1RX):**

Only Port 1 can be used as transmitting/receiving antenna.

**For UWB function (Radio 7):**

**For UWB mode (2TX/4RX):**

For 2TX

Port 1 and Port 2 can be use as transmitting antenna.

Port 1 and Port 2 could transmit simultaneously.

For 4RX

Port 1, Port 2, Port 3 and Port 4 can be used as receiving antennas.

Port 1, Port 2, Port 3 and Port 4 could receive simultaneously.

**For GPS function (Radio 8):**

**For GPS mode (1RX):**

Only Port 1 can be used as receiving antenna.

**1.1.3 Mode Test Duty Cycle**

Mode	DC	DCF(dB)	T(s)	VBW(Hz)_1/T
BT-LE(1Mbps)	0.635	1.97	401.25u	3k
BT-LE(2Mbps)	0.34	4.69	212.5u	10k

**Note:**

- ◆ DC is Duty Cycle.
- ◆ DCF is Duty Cycle Factor.



1.1.4 EUT Operational Condition

<b>EUT Power Type</b>	From PoE	
<b>Test Software Version</b>	Tera Term v4.75	
<b>Support Mode</b>	<input checked="" type="checkbox"/>	LE 1M PHY: 1 Mb/s
	<input checked="" type="checkbox"/>	LE Coded PHY (S=2): 500 Kb/s
	<input checked="" type="checkbox"/>	LE Coded PHY (S=8): 125 Kb/s
	<input checked="" type="checkbox"/>	LE 2M PHY: 2 Mb/s

Note: The above information was declared by manufacturer.

1.1.5 Table for EUT Support Function

Function	Supports Band
AP	2.4GHz, 5GHz UNII 1~3, 6GHz UNII 5~8, Bluetooth, Zigbee, UWB and GPS
Mesh	6GHz UNII 5~8

Note: The above information was declared by manufacturer.

1.1.6 Table for Multiple Listing

Equipment Name	Model Name	Software	Frequencies supported by 320MHz
Cisco Wireless 9178I Series Wi-Fi 7 Access Point	CW9178I	Cisco	6105, 6265, 6425, 6745 MHz
		Meraki	6105, 6265, 6425, 6585, 6745, 6905 MHz

Note: The above information was declared by manufacturer.

1.1.7 Table for Radio function

Radio \ Function	WLAN 2.4GHz	WLAN 5GHz	WLAN 6GHz	Bluetooth	Zigbee	UWB	GPS
1	V	-	-	-	-	-	-
2	-	V (UNII 1~2A)	-	-	-	-	-
3	-	V (UNII 2C~3/UNII 1~3)	-	-	-	-	-
4	-	-	V	-	-	-	-
5 (Scanning Radio)	V	V (UNII 1~3)	V	-	-	-	-
6	-	-	-	V	V	-	-
7	-	-	-	-	-	V	-
8	-	-	-	-	-	-	V

Note1: The above information was declared by manufacturer.

Note2: For WLAN 2.4GHz: The Radio 1 and Radio 5 can't operate at the same frequency.

For WLAN 5GHz: The Radio 2, 3, 5 can't operate at the same frequency.

For WLAN 6GHz: The Radio 4 and Radio 5 can't operate at the same frequency simultaneously.



**1.1.8 Table for EUT Operation Function**

<b>Mode</b>	<b>Operation Function</b>
1	R1: 2.4GHz+R2: 5GHz Low Band+R3: 5GHz Full Band/High band+R4: 6GHz+R5: 2.4GHz+R6: Bluetooth+R7: UWB
2	R1: 2.4GHz+R2: 5GHz Low Band+R3: 5GHz Full Band/High band+R4: 6GHz+R5: 5GHz+R6: Bluetooth+R7: UWB
3	R1: 2.4GHz+R2: 5GHz Low Band+R3: 5GHz Full Band/High band+R4: 6GHz+R5: 6GHz+R6: Bluetooth+R7: UWB
4	R1: 2.4GHz+R2: 5GHz Low Band+R3: 5GHz Full Band/High band+R4: 6GHz+R5: 2.4GHz+R6: Zigbee+R7: UWB
5	R1: 2.4GHz+R2: 5GHz Low Band+R3: 5GHz Full Band/High band+R4: 6GHz+R5: 5GHz+R6: Zigbee+R7: UWB
6	R1: 2.4GHz+R2: 5GHz Low Band+R3: 5GHz Full Band/High band+R4: 6GHz+R5: 6GHz+R6: Zigbee+R7: UWB

Note: The above information was declared by manufacturer.



### 1.2 Applicable Standards

According to the specifications of the manufacturer, the EUT must comply with the requirements of the following standards:

- ◆ 47 CFR FCC Part 15.247
- ◆ ANSI C63.10-2013

The following reference test guidance is not within the scope of accreditation of TAF.

- ◆ FCC KDB 558074 D01 v05r02
- ◆ FCC KDB 414788 D01 v01r01

### 1.3 Testing Location Information

Testing Location Information	
Test Lab. : Sporton International Inc. Hsinchu Laboratory	
Hsinchu (TAF: 3787)	ADD: No.8, Ln. 724, Bo'ai St., Zhubei City, Hsinchu County 302010, Taiwan (R.O.C.) TEL: 886-3-656-9065 FAX: 886-3-656-9085 Test site Designation No. TW3787 with FCC. Conformity Assessment Body Identifier (CABID) TW3787 with ISED.

Test Condition	Test Site No.	Test Engineer	Test Environment (°C / %)	Test Date
RF Conducted	TH03-CB	Ken Yeh	21.4~22.7 / 66~69	Mar. 04, 2024~ May 24, 2024
Radiated (below 1GHz)	03CH05-CB	Gordon Hung	21.6-22.7 / 56-59	May 30, 2024
Radiated (above 1GHz)	03CH04-CB	Gordon Hung	22.7-23.8 / 56-59	Feb. 21, 2024~ Apr. 24, 2024
AC Conduction	CO01-CB	Bob Chang	22~23 / 55~56	Jun. 06, 2024~ Jun. 11, 2024



### 1.4 Measurement Uncertainty

ISO/IEC 17025 requires that an estimate of the measurement uncertainties associated with the emissions test results be included in the report. The measurement uncertainties given below are based on a 95% confidence level (based on a coverage factor (k=2))

**Test Date: Date Before May 28, 2024**

Test Items	Uncertainty	Remark
Radiated Emission (1GHz ~ 18GHz)	4.1 dB	Confidence levels of 95%
Radiated Emission (18GHz ~ 40GHz)	4.2 dB	Confidence levels of 95%
Conducted Emission	3.1 dB	Confidence levels of 95%
Output Power Measurement	0.8 dB	Confidence levels of 95%
Power Density Measurement	3.1 dB	Confidence levels of 95%
Bandwidth Measurement	2.2%	Confidence levels of 95%

**Test Date: Date After May 27, 2024**

Test Items	Uncertainty	Remark
Conducted Emission (150kHz ~ 30MHz)	3.4 dB	Confidence levels of 95%
Radiated Emission (9kHz ~ 30MHz)	4.1 dB	Confidence levels of 95%
Radiated Emission (30MHz ~ 1,000MHz)	4.2 dB	Confidence levels of 95%



## 2 Test Configuration of EUT

### 2.1 Test Channel Mode

Mode
BT-LE(1Mbps)
2402MHz
2440MHz
2480MHz
BT-LE(2Mbps)
2402MHz
2440MHz
2478MHz
2480MHz



## 2.2 The Worst Case Measurement Configuration

The Worst Case Mode for Following Conformance Tests	
<b>Tests Item</b>	AC power-line conducted emissions
<b>Condition</b>	AC power-line conducted measurement for line and neutral Test Voltage: 120Vac / 60Hz
<b>Operating Mode</b>	CTX
1	EUT + Radio 1(2.4GHz) + LAN 0 port + PoE 1
2	EUT + Radio 1(2.4GHz) + LAN 1 port + PoE 1
Mode 2 has been evaluated to be the worst case among Mode 1~2, thus measurement for Mode 3~9 will follow this same test mode.	
3	EUT + Radio 1(2.4GHz) + LAN 1 port + PoE 2
4	EUT + Radio 1(2.4GHz) + LAN 1 port + PoE 3
5	EUT + Radio 1(2.4GHz) + LAN 1 port + PoE 4
6	EUT + Radio 1(2.4GHz) + LAN 1 port + PoE 5
7	EUT + Radio 1(2.4GHz) + LAN 1 port + PoE 6
8	EUT + Radio 1(2.4GHz) + LAN 1 port + PoE 7
9	EUT + Radio 1(2.4GHz) + LAN 1 port + PoE 8
Mode 5 has been evaluated to be the worst case among Mode 1~9, thus measurement for Mode 10~17 will follow this same test mode.	
10	EUT + Radio 2(5GHz Low Band) + LAN 1 port + PoE 4
11	EUT + Radio 3(5GHz Full Band/High Band) + LAN 1 port + PoE 4
12	EUT + Radio 4(6GHz Full Band) + LAN 1 port + PoE 4
13	EUT + Scanning Radio 5(2.4GHz) + LAN 1 port + PoE 4
14	EUT + Scanning Radio 5(5GHz Full Band) + LAN 1 port + PoE 4
15	EUT + Scanning Radio 5(6GHz Full Band) + LAN 1 port + PoE 4
16	EUT + Radio 6(Bluetooth) + LAN 1 port + PoE 4
17	EUT + Radio 6(Zigbee) + LAN 1 port + PoE 4
For operating mode 5 is the worst case and it was record in this test report.	

The Worst Case Mode for Following Conformance Tests	
<b>Tests Item</b>	DTS Bandwidth Maximum Conducted Output Power Power Spectral Density Emissions in Non-restricted Frequency Bands
<b>Test Condition</b>	Conducted measurement at transmit chains
1	Radio 6





<b>The Worst Case Mode for Following Conformance Tests</b>	
<b>Tests Item</b>	Emissions in Restricted Frequency Bands
<b>Test Condition</b>	Radiated measurement If EUT consist of multiple antenna assembly (multiple antenna are used in EUT regardless of spatial multiplexing MIMO configuration), the radiated test should be performed with highest antenna gain of each antenna type.
<b>Operating Mode &lt; 1GHz</b>	CTX
After evaluating, the worst case was found at as below for Emissions in Restricted Frequency Bands above 1GHz. Thus, the measurement will follow this same test configuration.	
1	EUT in Y-axis + Radio 1(2.4GHz) + LAN0 port + PoE 1
2	EUT in Y-axis + Radio 1(2.4GHz) + LAN1 port + PoE 1
Mode 2 has been evaluated to be the worst case among Mode 1~2, thus measurement for Mode 3~9 will follow this same test mode.	
3	EUT in Y-axis + Radio 1(2.4GHz) + LAN1 port + PoE 2
4	EUT in Y-axis + Radio 1(2.4GHz) + LAN1 port + PoE 3
5	EUT in Y-axis + Radio 1(2.4GHz) + LAN1 port + PoE 4
6	EUT in Y-axis + Radio 1(2.4GHz) + LAN1 port + PoE 5
7	EUT in Y-axis + Radio 1(2.4GHz) + LAN1 port + PoE 6
8	EUT in Y-axis + Radio 1(2.4GHz) + LAN1 port + PoE 7
9	EUT in Y-axis + Radio 1(2.4GHz) + LAN1 port + PoE 8
Mode 6 has been evaluated to be the worst case among Mode 1~9, thus measurement for Mode 10~17 will follow this same test mode.	
10	EUT in X-axis + Radio 2(5GHz Low Band) + LAN1 port + PoE 5
11	EUT in Z-axis + Radio 3(5GHz Full Band/High Band) + LAN1 port + PoE 5
12	EUT in X-axis + Radio 4(6GHz Full Band) + LAN1 port + PoE 5
13	EUT in Z-axis + Scanning Radio 5(2.4GHz) + LAN1 port + PoE 5
14	EUT in Y-axis + Scanning Radio 5(5GHz Full Band) + LAN1 port + PoE 5
15	EUT in Z-axis + Scanning Radio 5(6GHz Full Band) + LAN1 port + PoE 5
16	EUT in X-axis + Radio 6(Bluetooth) + LAN1 port + PoE 5
17	EUT in X-axis + Radio 6(Zigbee) + LAN1 port + PoE 5
For operating mode 15 is the worst case and it was record in this test report.	
<b>Operating Mode &gt; 1GHz</b>	CTX
After evaluating, and the worst case was found at X-axis, so it was selected to perform test and its test result was written in the report.	
1	EUT in X-axis + Radio 6(Bluetooth)



The Worst Case Mode for Following Conformance Tests	
<b>Tests Item</b>	Simultaneous Transmission Analysis - Co-location RF Exposure Evaluation
<b>Operating Mode</b>	
1	Radio 1(2.4GHz) + Radio 2(5GHz Low Band) + Radio 3(5GHz Full Band/High Band) + Radio 4(6GHz Full Band) + Scanning Radio 5(2.4GHz) + Radio 6(Bluetooth) + Radio 7(UWB)
2	Radio 1(2.4GHz) + Radio 2(5GHz Low Band) + Radio 3(5GHz Full Band/High Band) + Radio 4(6GHz Full Band) + Scanning Radio 5(5GHz) + Radio 6(Bluetooth) + Radio 7(UWB)
3	Radio 1(2.4GHz) + Radio 2(5GHz Low Band) + Radio 3(5GHz Full Band/High Band) + Radio 4(6GHz Full Band) + Scanning Radio 5(6GHz) + Radio 6(Bluetooth) + Radio 7(UWB)
4	Radio 1(2.4GHz) + Radio 2(5GHz Low Band) + Radio 3(5GHz Full Band/High Band) + Radio 4(6GHz Full Band) + Scanning Radio 5(2.4GHz) + Radio 6(Zigbee) + Radio 7(UWB)
5	Radio 1(2.4GHz) + Radio 2(5GHz Low Band) + Radio 3(5GHz Full Band/High Band) + Radio 4(6GHz Full Band) + Scanning Radio 5(5GHz) + Radio 6(Zigbee) + Radio 7(UWB)
6	Radio 1(2.4GHz) + Radio 2(5GHz Low Band) + Radio 3(5GHz Full Band/High Band) + Radio 4(6GHz Full Band) + Scanning Radio 5(6GHz) + Radio 6(Zigbee) + Radio 7(UWB)
Refer to Sporton Test Report No.: FA411617 for Co-location RF Exposure Evaluation.	

Note: The PoEs are for measurement only, would not be marketed.  
 The information of PoE as below:

Power	Brand Name	Model Name
PoE 1	Microsemi	PD-9001GR/AT/AC
PoE 2	PHIHONG	POE29U-1AT(PL)
PoE 3	DELTA	ADH-65AR B
PoE 4	PHIHONG	POEA33U-1ATE
PoE 5	PHIHONG	POE60U-1BT-X
PoE 6	PHIHONG	POE60U-BTA(X66M-R)
PoE 7	PHIHONG	POE60U-BTA(X664-R)
PoE 8	DELTA	ADH-65AR P

### 2.3 EUT Operation during Test

The EUT was programmed to be in continuously transmitting mode.

### 2.4 Accessories

Accessories
Bracket 1*1
Bracket 2*1



## 2.5 Support Equipment

For AC Conduction:

Support Equipment				
No.	Equipment	Brand Name	Model Name	FCC ID
A	PoE 4	PHIHONG	POEA33U-1ATE	N/A
B	PC	ASUS	S300TA	TX2-RTL8821CE
C	Flash disk3.0	Transcend	JetFlash-703	N/A

For Radiated:

Support Equipment				
No.	Equipment	Brand Name	Model Name	FCC ID
A	Notebook	DELL	E4300	N/A
B	PoE 5	PHIHONG	POE60U-1BT-X	N/A

For RF Conducted:

Support Equipment				
No.	Equipment	Brand Name	Model Name	FCC ID
A	Notebook	Lenovo	L440	N/A
B	PoE 2	PHIHONG	POE29U-1AT(PL)	N/A

## 2.6 Test Setup Diagram

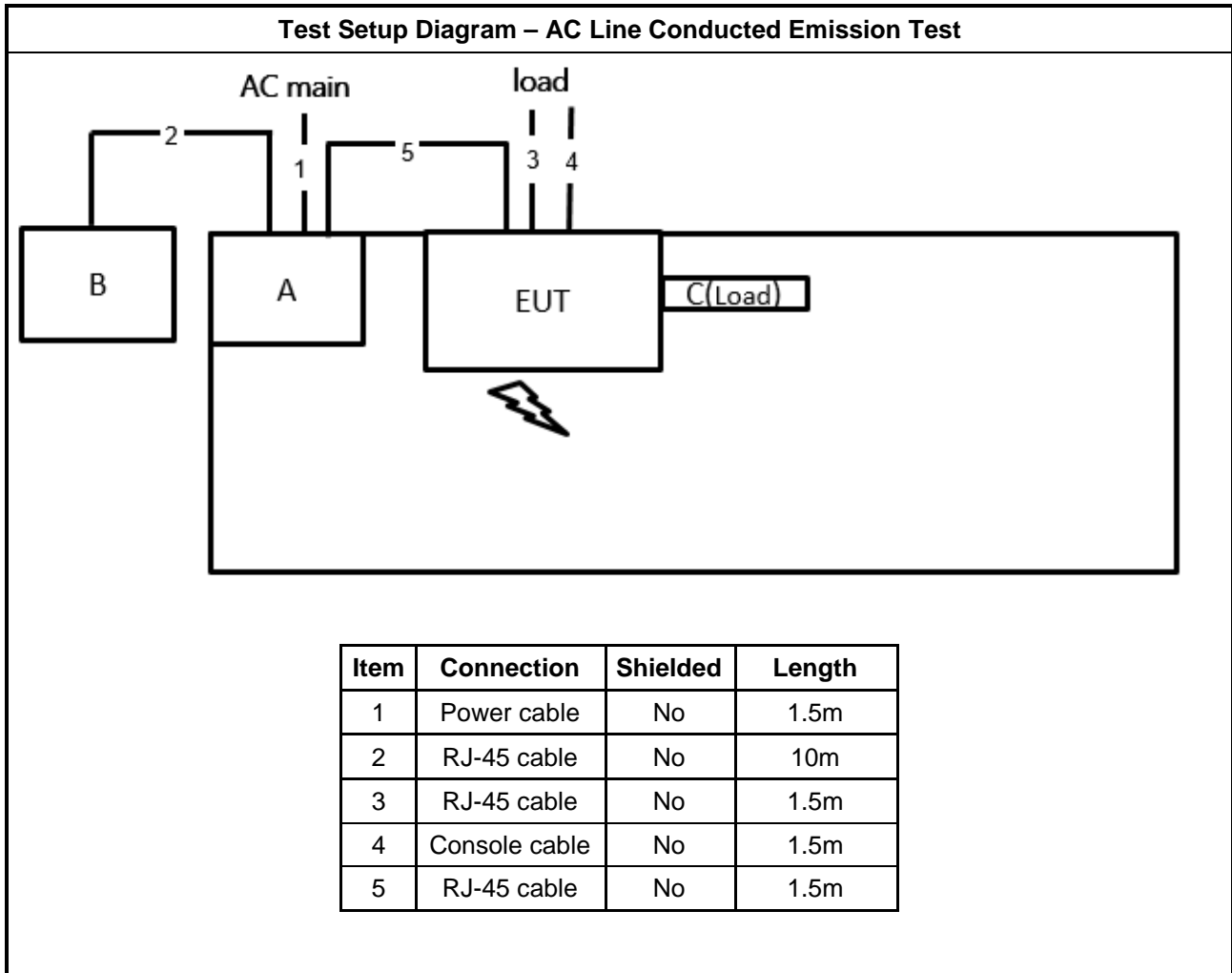



**Test Setup Diagram - Radiated Test < 1GHz**

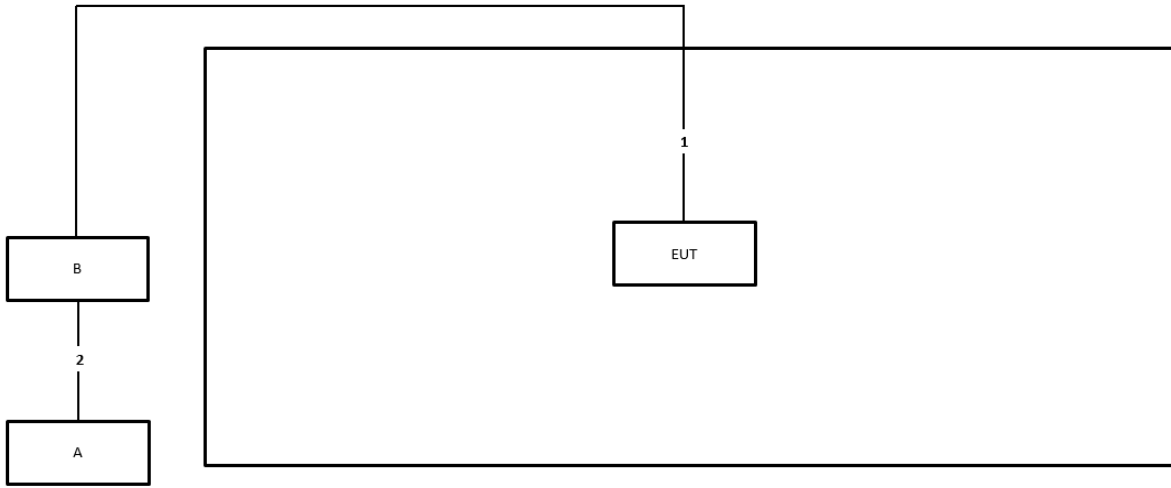

Item	Connection	Shielded	Length
1	RJ-45 cable	No	10m
2	RJ-45 cable	No	1m

**Test Setup Diagram - Radiated Test > 1GHz**

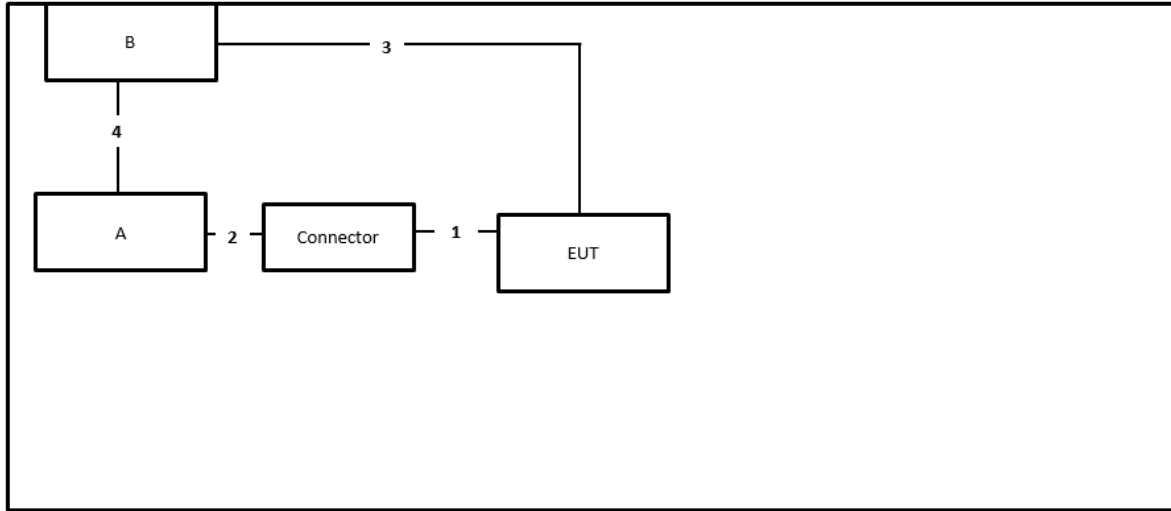

Item	Connection	Shielded	Length
1	Console cable (RS232 to RJ45)	No	1m
2	Console cable (RS232 to USB)	No	1m
3	RJ-45 cable	No	1m
4	RJ-45 cable	No	1m



### 3 Transmitter Test Result

#### 3.1 AC Power-line Conducted Emissions

##### 3.1.1 AC Power-line Conducted Emissions Limit

AC Power-line Conducted Emissions Limit		
Frequency Emission (MHz)	Quasi-Peak	Average
0.15-0.5	66 - 56 *	56 - 46 *
0.5-5	56	46
5-30	60	50

Note 1: \* Decreases with the logarithm of the frequency.

##### 3.1.2 Measuring Instruments

Refer a test equipment and calibration data table in this test report.

##### 3.1.3 Test Procedures

Test Method
▪ Refer as ANSI C63.10-2013, clause 6.2 for AC power-line conducted emissions.

### 3.1.4 Test Setup

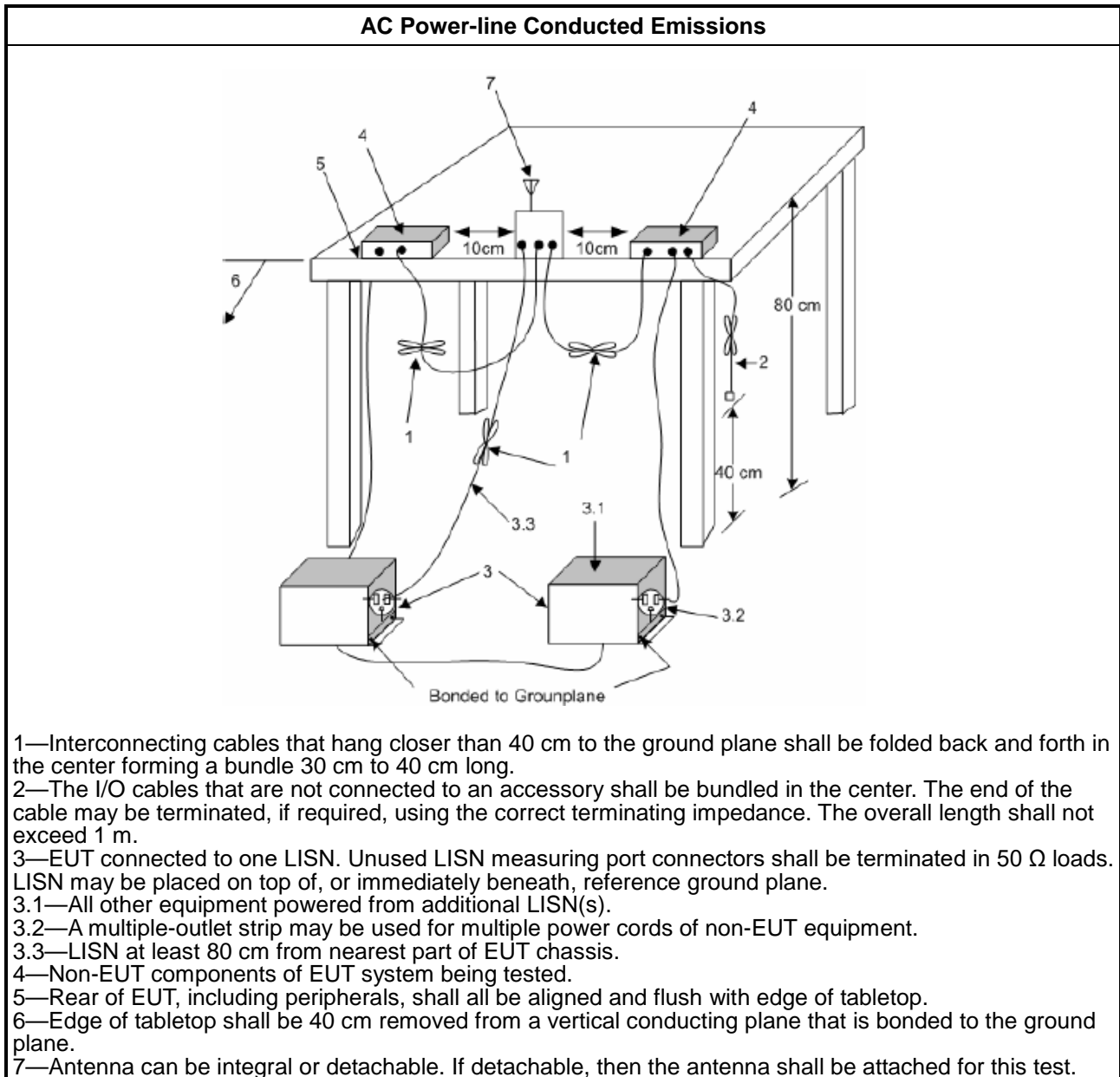

#### 1.1.1. Measurement Results Calculation

The measured Level is calculated using:

- a. Corrected Reading: LISN Factor (LISN) + Attenuator (AT/AUX) + Cable Loss (CL) + Read Level (Raw) = Level
- b. Margin = -Limit + Level

### 3.1.5 Test Result of AC Power-line Conducted Emissions

Refer as Appendix A



### 3.2 DTS Bandwidth

#### 3.2.1 6dB Bandwidth Limit

6dB Bandwidth Limit
<b>Systems using digital modulation techniques:</b>
<ul style="list-style-type: none"> <li>▪ 6 dB bandwidth <math>\geq</math> 500 kHz.</li> </ul>

#### 3.2.2 Measuring Instruments

Refer a test equipment and calibration data table in this test report.

#### 3.2.3 Test Procedures

Test Method
<ul style="list-style-type: none"> <li>▪ For the emission bandwidth shall be measured using one of the options below:</li> </ul>
<input checked="" type="checkbox"/> Refer as FCC KDB 558074, clause 8.2 & C63.10 clause 11.8.1 Option 1 for 6 dB bandwidth measurement.
<input type="checkbox"/> Refer as FCC KDB 558074, clause 8.2 & C63.10 clause 11.8.2 Option 2 for 6 dB bandwidth measurement.
<input type="checkbox"/> Refer as ANSI C63.10, clause 6.9.1 for occupied bandwidth testing.

#### 3.2.4 Test Setup

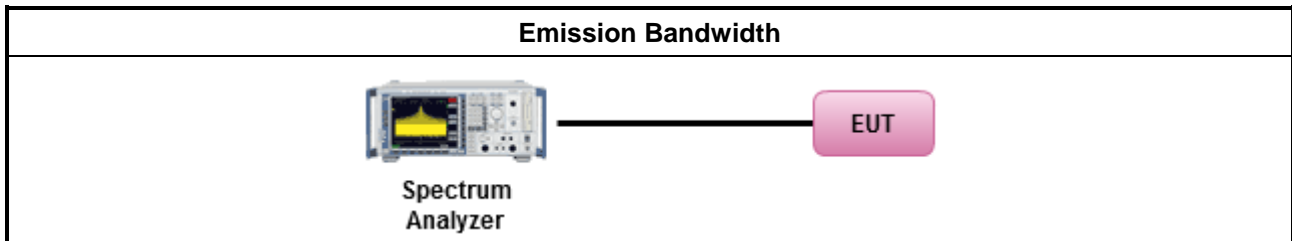

#### 3.2.5 Test Result of Emission Bandwidth

Refer as Appendix B



### 3.3 Maximum Conducted Output Power

#### 3.3.1 Maximum Conducted Output Power Limit

Maximum Conducted Output Power Limit	
	<ul style="list-style-type: none"><li>▪ If <math>G_{TX} \leq 6</math> dBi, then <math>P_{Out} \leq 30</math> dBm (1 W)</li></ul>
	<ul style="list-style-type: none"><li>▪ If <math>G_{TX} &gt; 6</math> dBi, then <math>P_{Out} = 30 - (G_{TX} - 6)</math> dBm</li></ul>
$P_{Out}$ = maximum peak conducted output power or maximum conducted output power in dBm, $G_{TX}$ = the maximum transmitting antenna directional gain in dBi.	

#### 3.3.2 Measuring Instruments

Refer a test equipment and calibration data table in this test report.

**3.3.3 Test Procedures**

Test Method	
<ul style="list-style-type: none"> <li>▪ Maximum Peak Conducted Output Power</li> </ul>	
	<input type="checkbox"/> Refer as FCC KDB 558074, clause 8.3.1.1 & C63.10 clause 11.9.1.1 (RBW ≥ EBW method).
	<input type="checkbox"/> Refer as FCC KDB 558074, clause 8.3.1.3 & C63.10 clause 11.9.1.3 (peak power meter).
<ul style="list-style-type: none"> <li>▪ Maximum Conducted Output Power</li> </ul>	
[duty cycle ≥ 98% or external video / power trigger]	
	<input type="checkbox"/> Refer as FCC KDB 558074, clause 8.3.2.2 & C63.10 clause 11.9.2.2.2 Method AVGSA-1.
	<input type="checkbox"/> Refer as FCC KDB 558074, clause 8.3.2.2 & C63.10 clause 11.9.2.2.3 Method AVGSA-1A. (alternative)
duty cycle < 98% and average over on/off periods with duty factor	
	<input type="checkbox"/> Refer as FCC KDB 558074, clause 8.3.2.2 & C63.10 clause 11.9.2.2.4 Method AVGSA-2.
	<input type="checkbox"/> Refer as FCC KDB 558074, clause 8.3.2.2 & C63.10 clause 11.9.2.2.5 Method AVGSA-2A (alternative)
	<input type="checkbox"/> Refer as FCC KDB 558074, clause 8.3.2.2 & C63.10 clause 11.9.2.2.6 Method AVGSA-3
	<input type="checkbox"/> Refer as FCC KDB 558074, clause 8.3.2.2 & C63.10 clause 11.9.2.2.7 Method AVGSA-3A (alternative)
Measurement using a power meter (PM)	
	<input type="checkbox"/> Refer as FCC KDB 558074, clause 8.3.2.3 & C63.10 clause 11.9.2.3.1 Method AVGPM (using an RF average power meter).
	<input checked="" type="checkbox"/> Refer as FCC KDB 558074, clause 8.3.2.3 & C63.10 clause 11.9.2.3.2 Method AVGPM-G (using an gate RF average power meter).
<ul style="list-style-type: none"> <li>▪ For conducted measurement.</li> </ul>	
	<ul style="list-style-type: none"> <li>▪ If the EUT supports multiple transmit chains using options given below: Refer as FCC KDB 662911, In-band power measurements. Using the measure-and-sum approach, measured all transmit ports individually. Sum the power (in linear power units e.g., mW) of all ports for each individual sample and save them.</li> </ul>
	<ul style="list-style-type: none"> <li>▪ If multiple transmit chains, EIRP calculation could be following as methods:  <math>P_{total} = P_1 + P_2 + \dots + P_n</math>            (calculated in linear unit [mW] and transfer to log unit [dBm])  <math>EIRP_{total} = P_{total} + DG</math> </li> </ul>

**3.3.4 Test Setup**

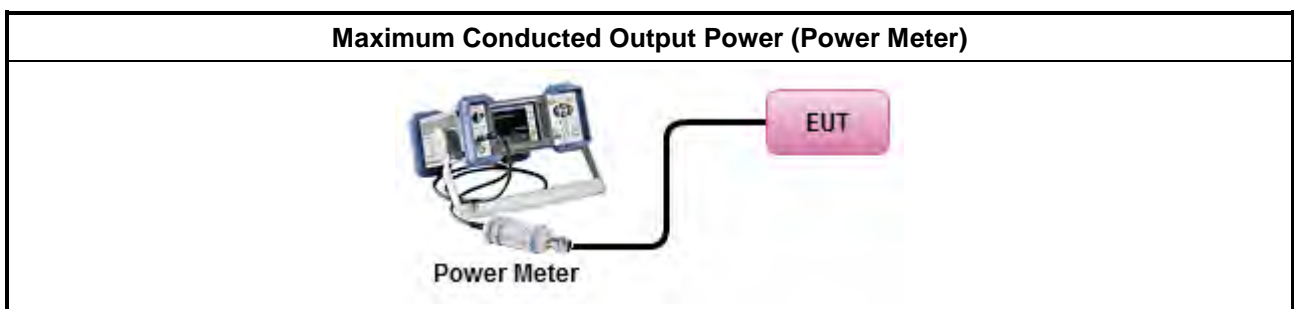



### **3.3.5 Test Result of Maximum Conducted Output Power**

Refer as Appendix C



### 3.4 Power Spectral Density

#### 3.4.1 Power Spectral Density Limit

Power Spectral Density Limit
<ul style="list-style-type: none"> <li>Power Spectral Density (PSD) ≤ 8 dBm/3kHz</li> </ul>

#### 3.4.2 Measuring Instruments

Refer a test equipment and calibration data table in this test report.

#### 3.4.3 Test Procedures

Test Method
<ul style="list-style-type: none"> <li>Peak power spectral density procedures that the same method as used to determine the conducted output power. If maximum peak conducted output power was measured to demonstrate compliance to the output power limit, then the peak PSD procedure below (Method PKPSD) shall be used. If maximum conducted output power was measured to demonstrate compliance to the output power limit, then one of the average PSD procedures shall be used, as applicable based on the following criteria (the peak PSD procedure is also an acceptable option).</li> </ul>
<input checked="" type="checkbox"/> Refer as FCC KDB 558074, clause 8.4 & C63.10 clause 11.10 Method Max. PSD. [duty cycle ≥ 98% or external video / power trigger]
<ul style="list-style-type: none"> <li>For conducted measurement.</li> </ul>
<ul style="list-style-type: none"> <li>If The EUT supports multiple transmit chains using options given below: <ul style="list-style-type: none"> <li><input type="checkbox"/> Option 1: Measure and sum the spectra across the outputs. Refer as FCC KDB 662911, In-band power spectral density (PSD). Sample all transmit ports simultaneously using a spectrum analyzer for each transmit port. Where the trace bin-by-bin of each transmit port summing can be performed. (i.e., in the first spectral bin of output 1 is summed with that in the first spectral bin of output 2 and that from the first spectral bin of output 3, and so on up to the NTX output to obtain the value for the first frequency bin of the summed spectrum.). Add up the amplitude (power) values for the different transmit chains and use this as the new data trace.</li> <li><input type="checkbox"/> Option 2: Measure and sum spectral maxima across the outputs. With this technique, spectra are measured at each output of the device at the required resolution bandwidth. The maximum value (peak) of each spectrum is determined. These maximum values are then summed mathematically in linear power units across the outputs. These operations shall be performed separately over frequency spans that have different out-of-band or spurious emission limits,</li> <li><input type="checkbox"/> Option 3: Measure and add 10 log(N) dB, where N is the number of transmit chains. Refer as FCC KDB 662911, In-band power spectral density (PSD). Performed at each transmit chains and each transmit chains shall be compared with the limit have been reduced with 10 log(N). Or each transmit chains shall be add 10 log(N) to compared with the limit.</li> </ul> </li> </ul>

### 3.4.4 Test Setup

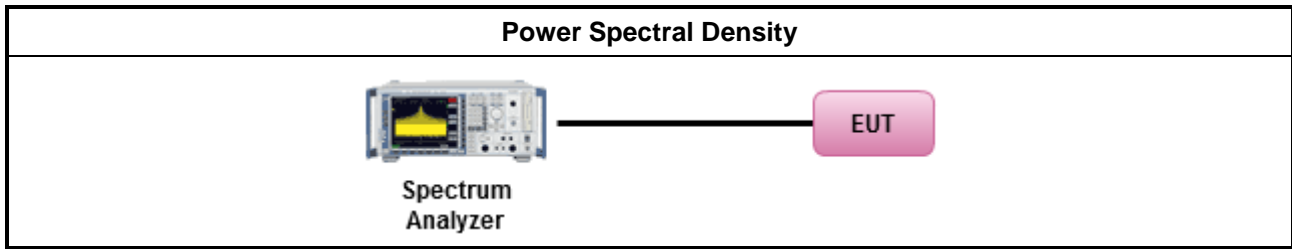

### 3.4.5 Test Result of Power Spectral Density

Refer as Appendix D

### 3.5 Emissions in Non-restricted Frequency Bands

#### 3.5.1 Emissions in Non-restricted Frequency Bands Limit

Un-restricted Band Emissions Limit	
RF output power procedure	Limit (dBc)
Peak output power procedure	20
Average output power procedure	30

Note 1: If the peak output power procedure is used to measure the fundamental emission power to demonstrate compliance to requirements, then the peak conducted output power measured within any 100 kHz outside the authorized frequency band shall be attenuated by at least 20 dB relative to the maximum measured in-band peak PSD level.

Note 2: If the average output power procedure is used to measure the fundamental emission power to demonstrate compliance to requirements, then the power in any 100 kHz outside of the authorized frequency band shall be attenuated by at least 30 dB relative to the maximum measured in-band average PSD level.

#### 3.5.2 Measuring Instruments

Refer a test equipment and calibration data table in this test report.

#### 3.5.3 Test Procedures

Test Method
<ul style="list-style-type: none"> <li>Refer as FCC KDB 558074, clause 8.5 for unwanted emissions into non-restricted bands.</li> </ul>

#### 3.5.4 Test Setup

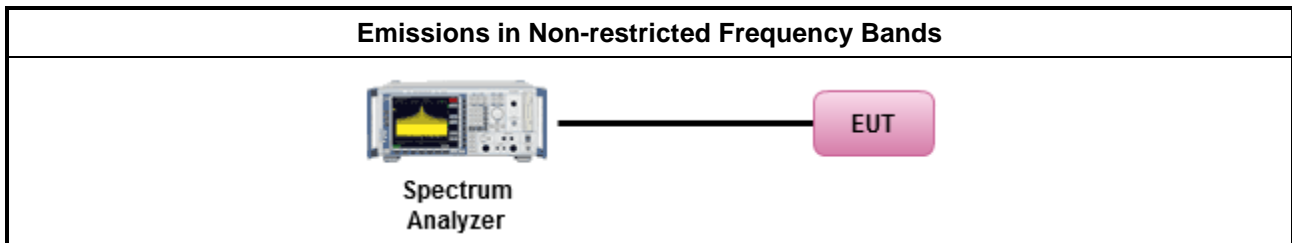

#### 3.5.5 Test Result of Emissions in Non-restricted Frequency Bands

Refer as Appendix E



### 3.6 Emissions in Restricted Frequency Bands

#### 3.6.1 Emissions in Restricted Frequency Bands Limit

Restricted Band Emissions Limit			
Frequency Range (MHz)	Field Strength (uV/m)	Field Strength (dBuV/m)	Measure Distance (m)
0.009~0.490	2400/F(kHz)	48.5 - 13.8	300
0.490~1.705	24000/F(kHz)	33.8 - 23	30
1.705~30.0	30	29	30
30~88	100	40	3
88~216	150	43.5	3
216~960	200	46	3
Above 960	500	54	3

Note 1: Test distance for frequencies at or above 30 MHz, measurements may be performed at a distance other than the limit distance provided they are not performed in the near field and the emissions to be measured can be detected by the measurement equipment. When performing measurements at a distance other than that specified, the results shall be extrapolated to the specified distance using an extrapolation factor of 20 dB/decade (inverse of linear distance for field-strength measurements, inverse of linear distance-squared for power-density measurements).

Note 2: Test distance for frequencies at below 30 MHz, measurements may be performed at a distance closer than the EUT limit distance; however, an attempt should be made to avoid making measurements in the near field. When performing measurements below 30 MHz at a closer distance than the limit distance, the results shall be extrapolated to the specified distance by either making measurements at a minimum of two or more distances on at least one radial to determine the proper extrapolation factor or by using the square of an inverse linear distance extrapolation factor (40 dB / decade). The test report shall specify the extrapolation method used to determine compliance of the EUT.

Note 3: Using the distance of 1m during the test for above 18 GHz, and the test value to correct for the distance factor at 3m.

#### 3.6.2 Measuring Instruments

Refer a test equipment and calibration data table in this test report.





**3.6.3 Test Procedures**

<b>Test Method</b>	
<ul style="list-style-type: none"> <li>▪ The average emission levels shall be measured in [duty cycle <math>\geq</math> 98 or duty factor].</li> </ul>	
<ul style="list-style-type: none"> <li>▪ Refer as ANSI C63.10, clause 6.10.3 band-edge testing shall be performed at the lowest frequency channel and highest frequency channel within the allowed operating band.</li> </ul>	
<ul style="list-style-type: none"> <li>▪ For the transmitter unwanted emissions shall be measured using following options below:</li> </ul>	
	<ul style="list-style-type: none"> <li>▪ Refer as FCC KDB 558074, clause 8.6 for unwanted emissions into restricted bands.</li> </ul>
	<input type="checkbox"/> Refer as FCC KDB 558074, clause 8.6 & C63.10 clause 11.12.2.5.1(trace averaging for duty cycle $\geq$ 98%).
	<input type="checkbox"/> Refer as FCC KDB 558074, clause 8.6 & C63.10 clause 11.12.2.5.2(trace averaging + duty factor).
	<input checked="" type="checkbox"/> Refer as FCC KDB 558074, clause 8.6 & C63.10 clause 11.12.2.5.3(Reduced VBW $\geq$ 1/T).
	<input type="checkbox"/> Refer as ANSI C63.10, clause 11.12.2.5.3 (Reduced VBW). VBW $\geq$ 1/T, where T is pulse time.
	<input type="checkbox"/> Refer as ANSI C63.10, clause 7.5 average value of pulsed emissions.
	<input checked="" type="checkbox"/> Refer as FCC KDB 558074, clause 8.6 & C63.10 clause 11.12.2.4 measurement procedure peak limit.
<ul style="list-style-type: none"> <li>▪ For the transmitter band-edge emissions shall be measured using following options below:</li> </ul>	
	<ul style="list-style-type: none"> <li>▪ Refer as FCC KDB 558074 clause 8.7 &amp; c63.10 clause 11.13.1, When the performing peak or average radiated measurements, emissions within 2 MHz of the authorized band edge may be measured using the marker-delta method described below.</li> </ul>
	<ul style="list-style-type: none"> <li>▪ Refer as FCC KDB 558074, clause 8.7 (ANSI C63.10, clause 6.10.6) for marker-delta method for band-edge measurements.</li> </ul>
	<ul style="list-style-type: none"> <li>▪ Refer as FCC KDB 558074, clause 8.7 for narrower resolution bandwidth (100kHz) using the band power and summing the spectral levels (i.e., 1 MHz).</li> </ul>
	<ul style="list-style-type: none"> <li>▪ For conducted unwanted emissions into restricted bands (absolute emission limits). Devices with multiple transmit chains using options given below:                (1) Measure and sum the spectra across the outputs or                (2) Measure and add 10 log(N) dB             </li> </ul>
	<ul style="list-style-type: none"> <li>▪ For FCC KDB 662911 The methodology described here may overestimate array gain, thereby resulting in apparent failures to satisfy the out-of-band limits even if the device is actually compliant. In such cases, compliance may be demonstrated by performing radiated tests around the frequencies at which the apparent failures occurred.</li> </ul>

**3.6.4 Test Setup**

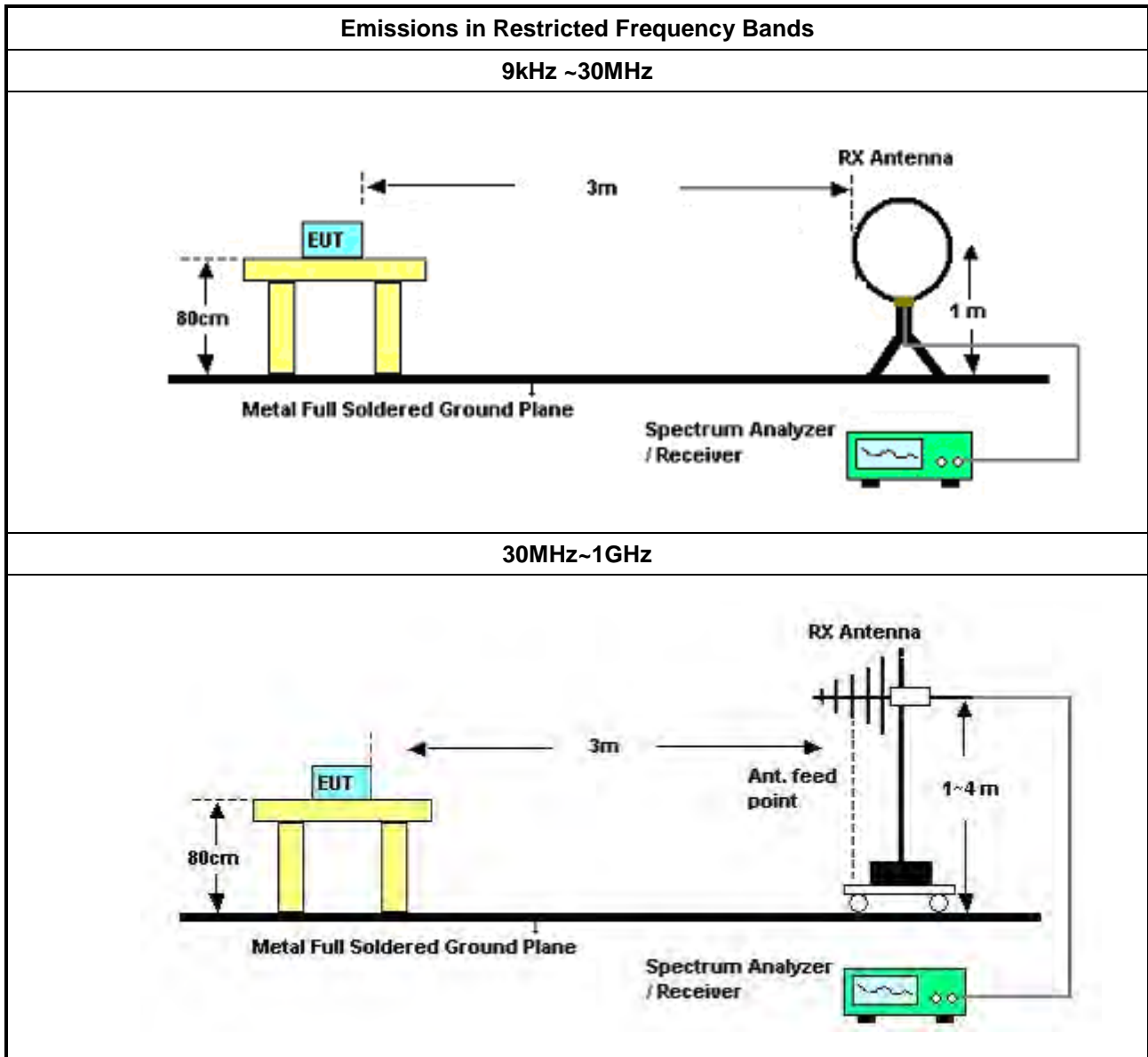

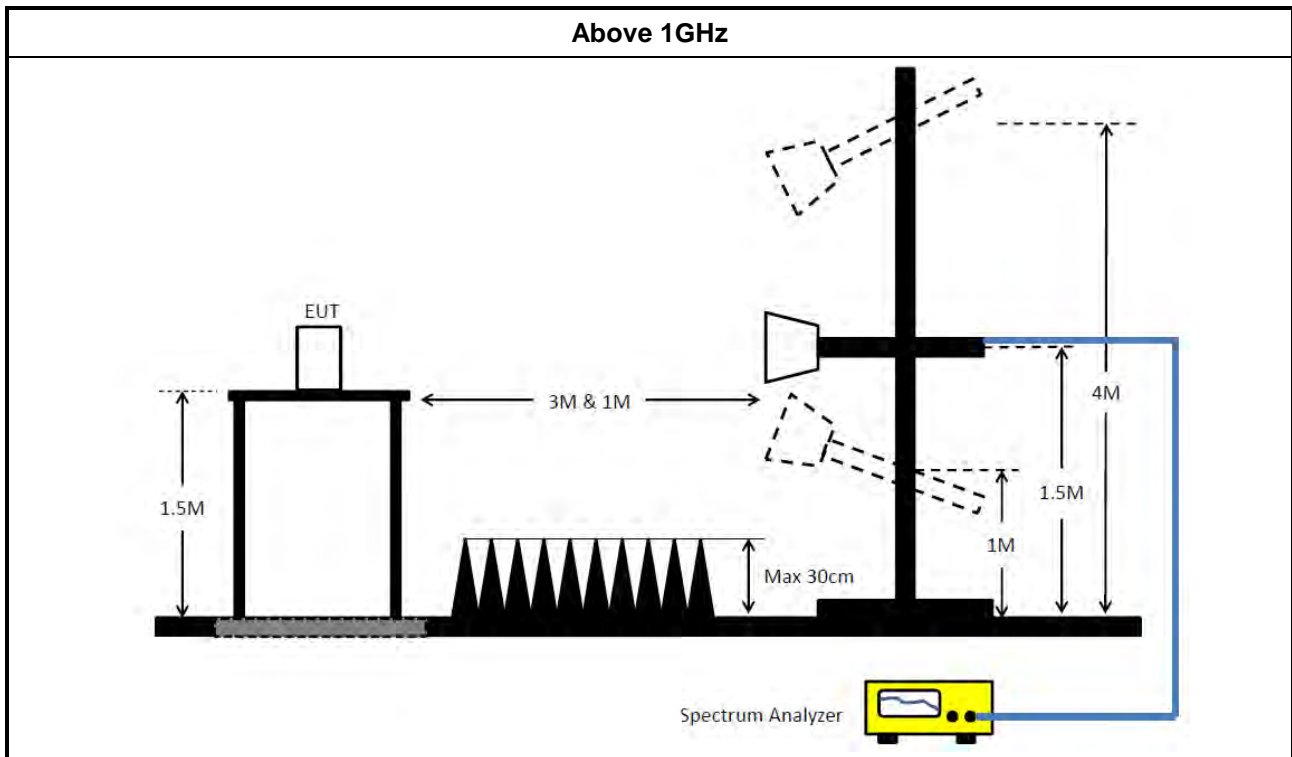

### 3.6.5 Measurement Results Calculation

The measured Level is calculated using:

Corrected Reading: Antenna factor (AF) + Cable loss (CL) + Read level (Raw) - Preamp factor (PA)(if applicable) = Level.

### 3.6.6 Emissions in Restricted Frequency Bands (Below 30MHz)

There is a comparison data of both open-field test site and alternative test site - semi-Anechoic chamber according to KDB414788 Radiated Test Site, and the result came out very similar.

All amplitude of spurious emissions that are attenuated by more than 20 dB below the permissible value has no need to be reported.

The radiated emissions were investigated from 9 kHz or the lowest frequency generated within the device, up to the 10th harmonic or 40 GHz, whichever is appropriate.

### 3.6.7 Test Result of Emissions in Restricted Frequency Bands

Refer as Appendix F



## 4 Test Equipment and Calibration Data

Instrument	Brand	Model No.	Serial No.	Characteristics	Calibration Date	Calibration Due Date	Remark
EMI Receiver	Agilent	N9038A	My52260123	9kHz ~ 8.4GHz	Mar. 01, 2024	Feb. 28, 2025	Conduction (CO01-CB)
LISN	F.C.C.	FCC-LISN-5 0-16-2	04083	150kHz ~ 100MHz	Feb. 19, 2024	Feb. 18, 2025	Conduction (CO01-CB)
LISN	Schwarzbeck	NSLK 8127	8127647	9kHz ~ 30MHz	Apr. 24, 2024	Apr. 23, 2025	Conduction (CO01-CB)
Pulse Limiter	Rohde&Schwarz	ESH3-Z2	100430	9kHz ~ 30MHz	Feb. 08, 2024	Feb. 07, 2025	Conduction (CO01-CB)
COND Cable	Woken	Cable	Low cable-CO01	9kHz ~ 30MHz	Oct. 17, 2023	Oct. 16, 2024	Conduction (CO01-CB)
Software	SPORTON	SENSE	V5.10	-	N.C.R.	N.C.R.	Conduction (CO01-CB)
Loop Antenna	Teseq	HLA 6121	65417	9kHz - 30 MHz	Oct. 13, 2023	Oct. 12, 2024	Radiation (03CH05-CB)
3m Semi Anechoic Chamber NSA	TDK	SAC-3M	03CH05-CB	30 MHz ~ 1 GHz	Aug. 02, 2023	Aug. 01, 2024	Radiation (03CH05-CB)
Bilog Antenna with 6dB Attenuator	TESEQ & EMCI	CBL 6112D & N-6-06	35236 & AT-N0610	30MHz ~ 2GHz	Mar. 23, 2024	Mar. 22, 2025	Radiation (03CH05-CB)
Amplifier	EMCI	EMC330N	980331	20MHz ~ 3GHz	May 02, 2024	May 01, 2025	Radiation (03CH05-CB)
Spectrum Analyzer	R&S	FSP40	100304	9kHz ~ 40GHz	Apr. 17, 2024	Apr. 16, 2025	Radiation (03CH05-CB)
EMI Test Receiver	R&S	ESCS	826547/017	9kHz ~ 2.75GHz	Jun. 13, 2023	Jun. 12, 2024	Radiation (03CH05-CB)
RF Cable-low	Woken	RG402	Low Cable-04+23	30MHz~1GHz	Dec. 06, 2023	Dec. 05, 2024	Radiation (03CH05-CB)
Test Software	SPORTON	SENSE	V5.10	-	N.C.R.	N.C.R.	Radiation (03CH05-CB)
3m Semi Anechoic Chamber VSWR	TDK	SAC-3M	03CH04-CB	1GHz ~18GHz 3m	Feb. 23, 2023	Feb. 22, 2024	Radiation (03CH04-CB)
3m Semi Anechoic Chamber VSWR	TDK	SAC-3M	03CH04-CB	1GHz ~18GHz 3m	Feb. 22, 2024	Feb. 21, 2025	Radiation (03CH04-CB)
Horn Antenna	ETS-Lindgren	3115	00143147	750MHz~18GHz	Oct. 04, 2023	Oct. 03, 2024	Radiation (03CH04-CB)
Horn Antenna	Schwarzbeck	BBHA 9170	BBHA9170252	15GHz ~ 40GHz	Sep. 04, 2023	Sep. 03, 2024	Radiation (03CH04-CB)
Pre-Amplifier	Agilent	83017A	MY53270063	0.5GHz ~ 26.5GHz	Jun. 30, 2023	Jun. 29, 2024	Radiation (03CH04-CB)



Instrument	Brand	Model No.	Serial No.	Characteristics	Calibration Date	Calibration Due Date	Remark
Spectrum Analyzer	R&S	FSP40	100142	9kHz~40GHz	Mar. 21, 2023	Mar. 20, 2024	Radiation (03CH04-CB)
Spectrum Analyzer	R&S	FSP40	100142	9kHz~40GHz	Mar. 19, 2024	Mar. 18, 2025	Radiation (03CH04-CB)
RF Cable-high	Woken	RG402	High Cable-21	1GHz - 18GHz	Oct. 02, 2023	Oct. 01, 2024	Radiation (03CH04-CB)
RF Cable-high	Woken	RG402	High Cable-21+67	1GHz - 18GHz	Oct. 02, 2023	Oct. 01, 2024	Radiation (03CH04-CB)
High Cable	Woken	WCA0929M	40G#5+6	1GHz ~ 40 GHz	Jan. 11, 2024	Jan. 10, 2025	Radiation (03CH04-CB)
Test Software	SPORTON	SENSE	V5.10	-	N.C.R.	N.C.R.	Radiation (03CH04-CB)
Spectrum analyzer	R&S	FSV40	101028	9kHz~40GHz	Dec. 22, 2023	Dec. 21, 2024	Conducted (TH03-CB)
Power Sensor	Anritsu	MA2411B	1726195	300MHz~40GHz	Sep. 04, 2023	Sep. 03, 2024	Conducted (TH03-CB)
Power Meter	Anritsu	ML2495A	1035008	300MHz~40GHz	Sep. 04, 2023	Sep. 03, 2024	Conducted (TH03-CB)
RF Cable	Woken	RG402	High Cable-11	30MHz ~18 GHz	Oct. 02, 2023	Oct. 01, 2024	Conducted (TH03-CB)
RF Cable	Woken	RG402	High Cable-12	30MHz ~18 GHz	Oct. 02, 2023	Oct. 01, 2024	Conducted (TH03-CB)
RF Cable	Woken	RG402	High Cable-13	30MHz ~18 GHz	Oct. 02, 2023	Oct. 01, 2024	Conducted (TH03-CB)
RF Cable-high	Woken	RG402	High Cable-14	1 GHz ~18 GHz	Oct. 02, 2023	Oct. 01, 2024	Conducted (TH03-CB)
RF Cable-high	Woken	RG402	High Cable-15	1 GHz ~18 GHz	Oct. 02, 2023	Oct. 01, 2024	Conducted (TH03-CB)
Switch	SPTCB	SP-SWI	SWI-03	1 ~26.5 GHz	Oct. 03, 2023	Oct. 02, 2024	Conducted (TH03-CB)
Test Software	SPORTON	SENSE	V5.10	-	N.C.R.	N.C.R.	Conducted (TH03-CB)

Note: Calibration Interval of instruments listed above is one year.  
NCR means Non-Calibration required.



**Summary**

Mode	Result	Type	Freq (Hz)	Level (dBuV)	Limit (dBuV)	Margin (dB)	Condition
Mode 5	Pass	QP	154.5k	61.65	65.75	-4.10	Line

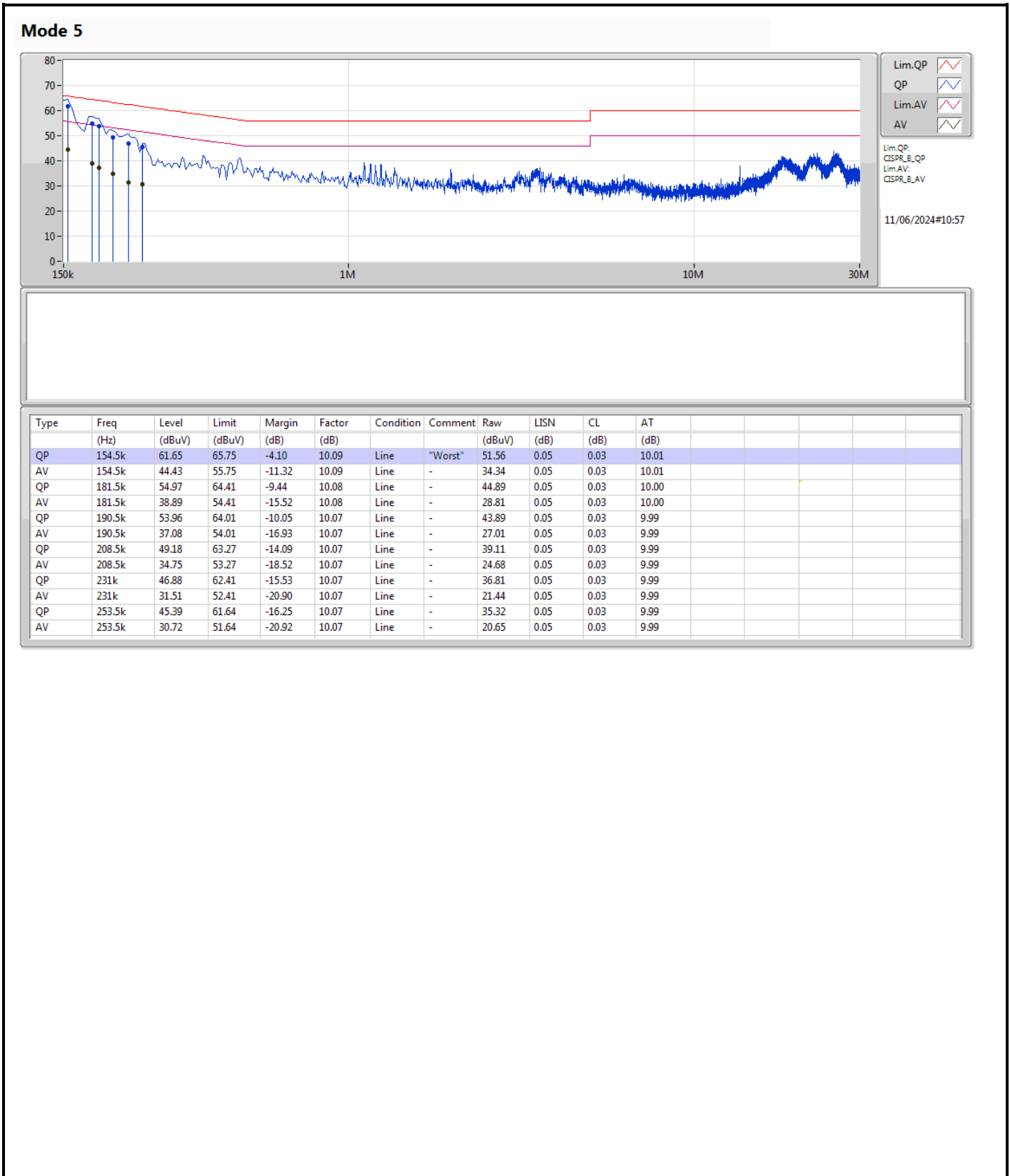

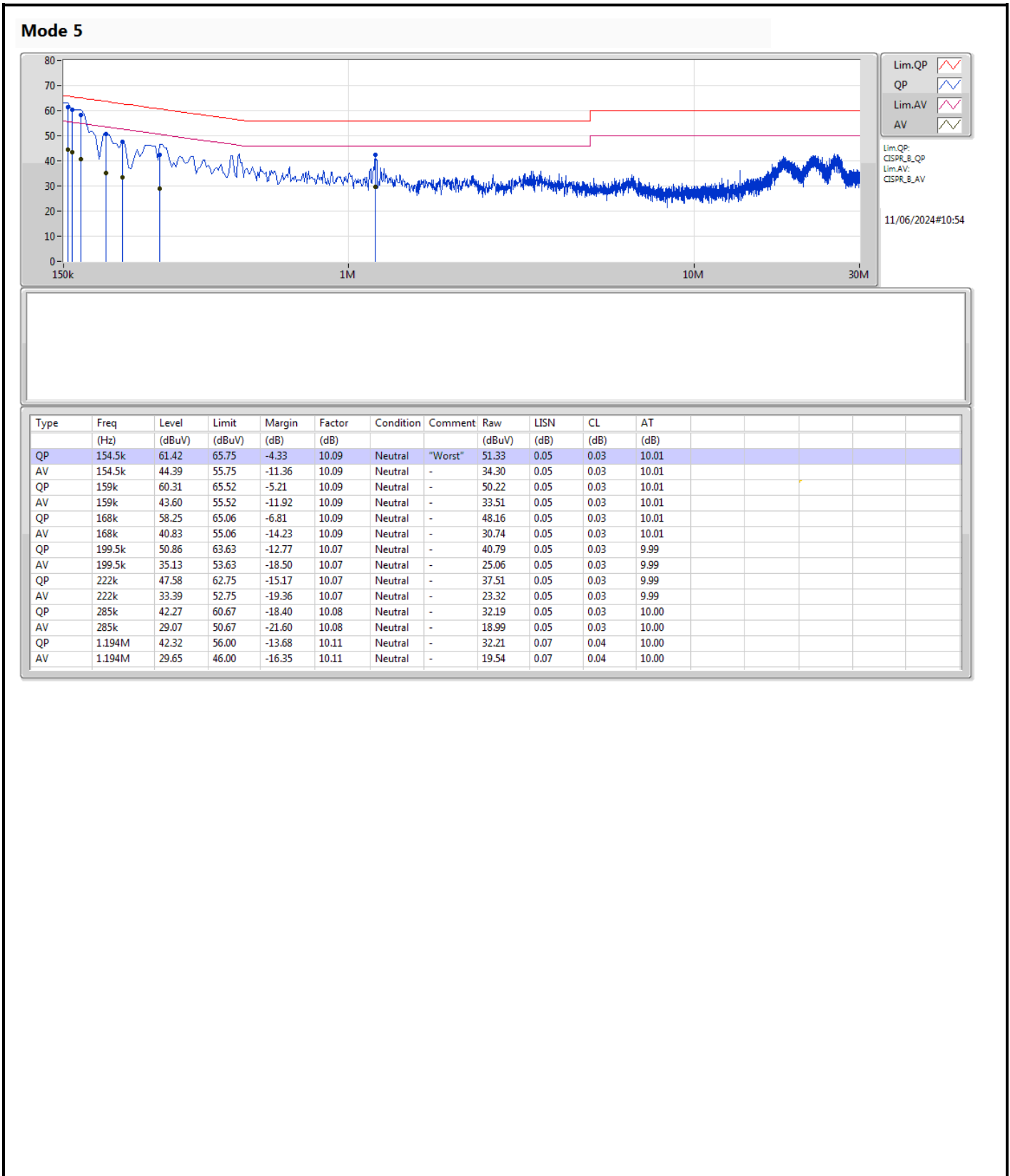





Summary

Mode	Max-N dB (Hz)	Max-OBW (Hz)	ITU-Code	Min-N dB (Hz)	Min-OBW (Hz)
2.4-2.4835GHz	-	-	-	-	-
BT-LE(1Mbps)	681.25k	1.034M	1M03F1D	676.25k	1.029M
BT-LE(2Mbps)	592.5k	2.074M	2M07F1D	590k	2.061M

Max-N dB = Maximum 6dB down bandwidth; Max-OBW = Maximum 99% occupied bandwidth;  
Min-N dB = Minimum 6dB down bandwidth; Min-OBW = Minimum 99% occupied bandwidth



Result

Mode	Result	Limit (Hz)	Port 1-N dB (Hz)	Port 1-OBW (Hz)
BT-LE(1Mbps)	-	-	-	-
2402MHz	Pass	500k	680k	1.034M
2440MHz	Pass	500k	676.25k	1.029M
2480MHz	Pass	500k	681.25k	1.03M
BT-LE(2Mbps)	-	-	-	-
2402MHz	Pass	500k	592.5k	2.061M
2440MHz	Pass	500k	590k	2.073M
2480MHz	Pass	500k	592.5k	2.074M

Port X-N dB = Port X 6dB down bandwidth;  
Port X-OBW = Port X 99% occupied bandwidth

2.4-2.4835GHz\_BT-LE(1Mbps)

EBW-DTS

2402MHz

14/03/2024

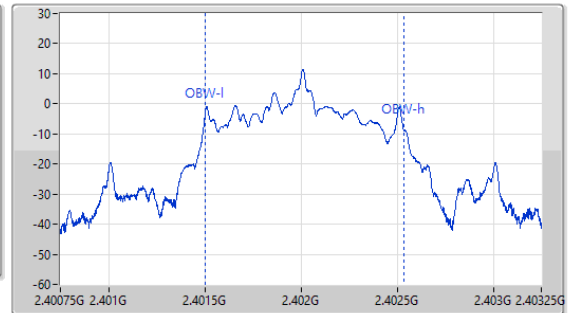
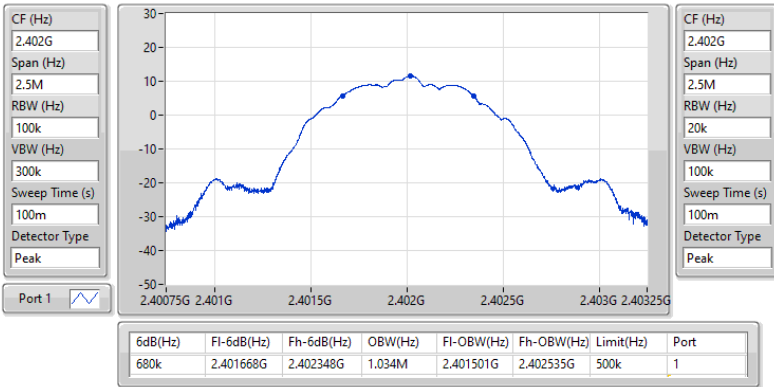

2.4-2.4835GHz\_BT-LE(1Mbps)

EBW-DTS

2440MHz

14/03/2024

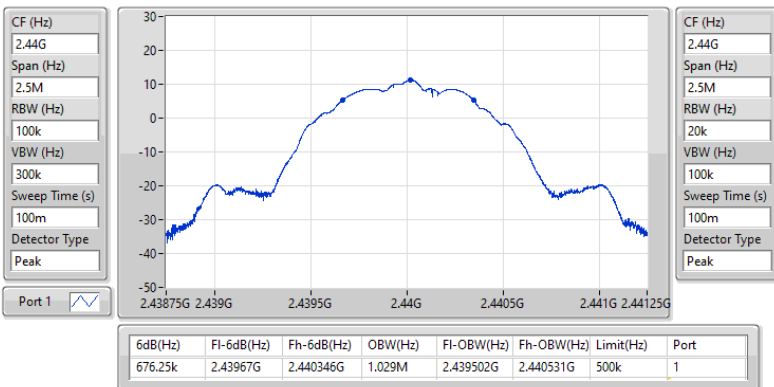

2.4-2.4835GHz\_BT-LE(1Mbps)

EBW-DTS

2480MHz

14/03/2024

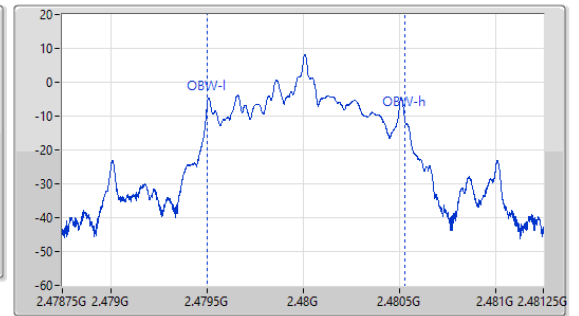
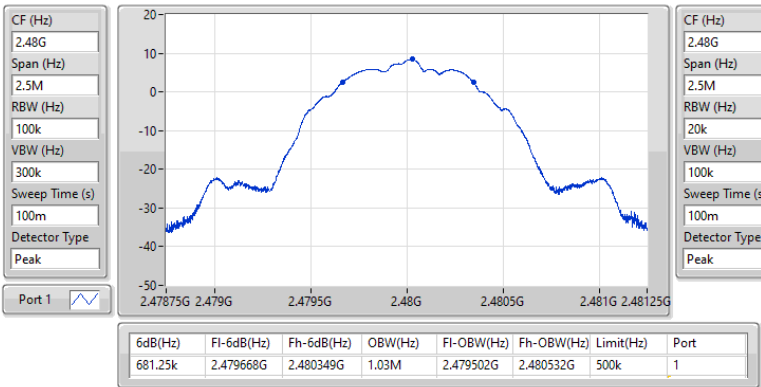

2.4-2.4835GHz\_BT-LE(2Mbps)

EBW-DTS

2402MHz

14/03/2024

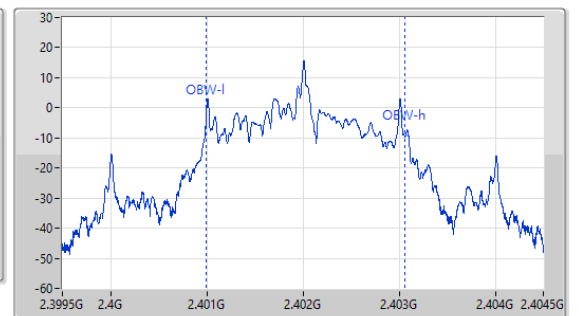
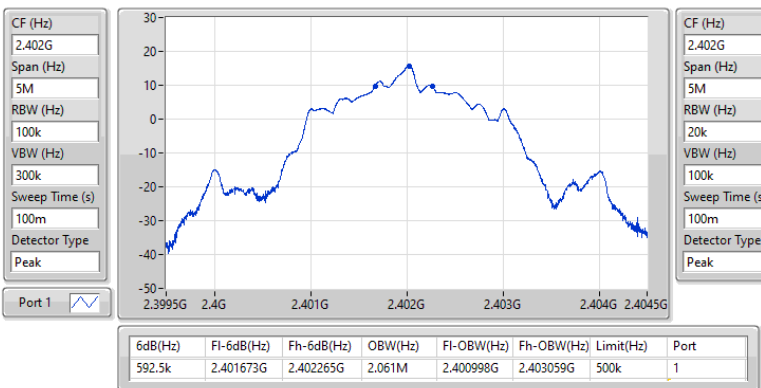

2.4-2.4835GHz\_BT-LE(2Mbps)

EBW-DTS

2440MHz

14/03/2024

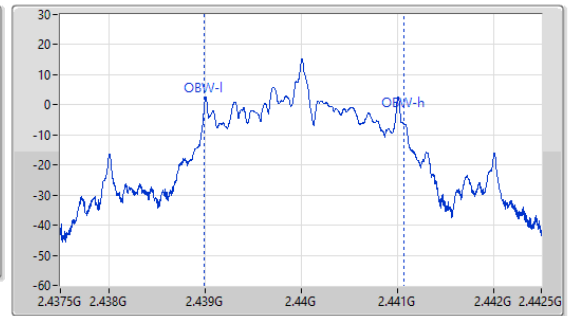
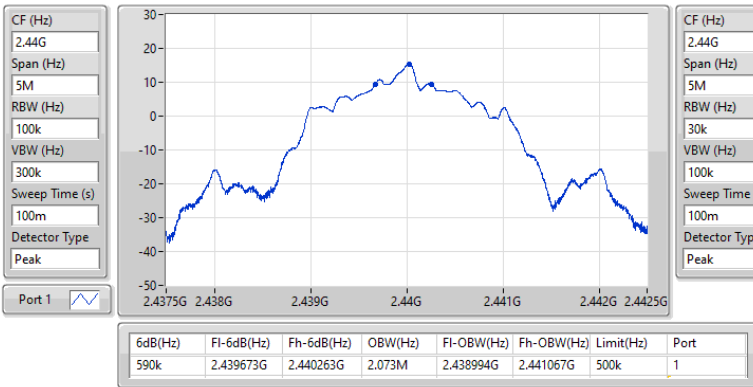

2.4-2.4835GHz\_BT-LE(2Mbps)

EBW-DTS

2480MHz

15/03/2024

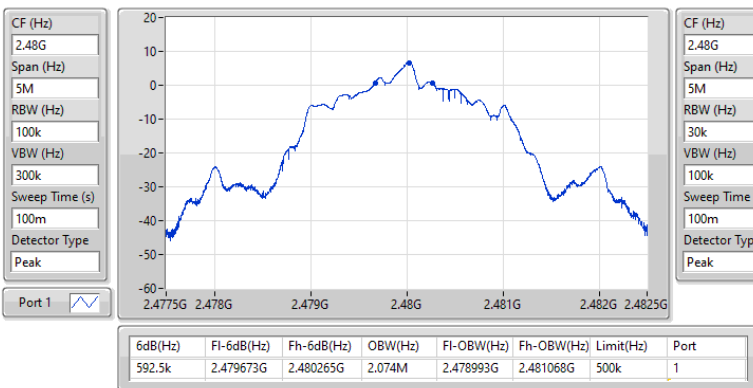



**Summary**

Mode	Total Power (dBm)	Total Power (W)
2.4-2.4835GHz	-	-
BT-LE(1Mbps)	11.84	0.01528
BT-LE(2Mbps)	15.88	0.03873



Result

Mode	Result	DG (dBi)	Total Power (dBm)	Power Limit (dBm)
BT-LE(1Mbps)	-	-	-	-
2402MHz	Pass	2.91	11.84	30.00
2440MHz	Pass	2.91	11.39	30.00
2480MHz	Pass	2.91	8.58	30.00
BT-LE(2Mbps)	-	-	-	-
2402MHz	Pass	2.91	15.88	30.00
2440MHz	Pass	2.91	15.71	30.00
2478MHz	Pass	2.91	15.24	30.00
2480MHz	Pass	2.91	4.13	30.00

DG = Directional Gain; Port X = Port X output power



Summary

Mode	PD (dBm/RBW)
2.4-2.4835GHz	-
BT-LE(1Mbps)	7.82
BT-LE(2Mbps)	7.80

RBW = 3kHz;





Result

Mode	Result	DG (dBi)	PD (dBm/RBW)	PD Limit (dBm/RBW)
BT-LE(1Mbps)	-	-	-	-
2402MHz	Pass	2.91	7.75	8.00
2440MHz	Pass	2.91	7.82	8.00
2480MHz	Pass	2.91	7.35	8.00
BT-LE(2Mbps)	-	-	-	-
2402MHz	Pass	2.91	7.80	8.00
2440MHz	Pass	2.91	7.65	8.00
2480MHz	Pass	2.91	-0.72	8.00

DG = Directional Gain; RBW = 3kHz;  
PD = trace bin-by-bin of each transmits port summing can be performed maximum power density; Port X = Port X Power Density;

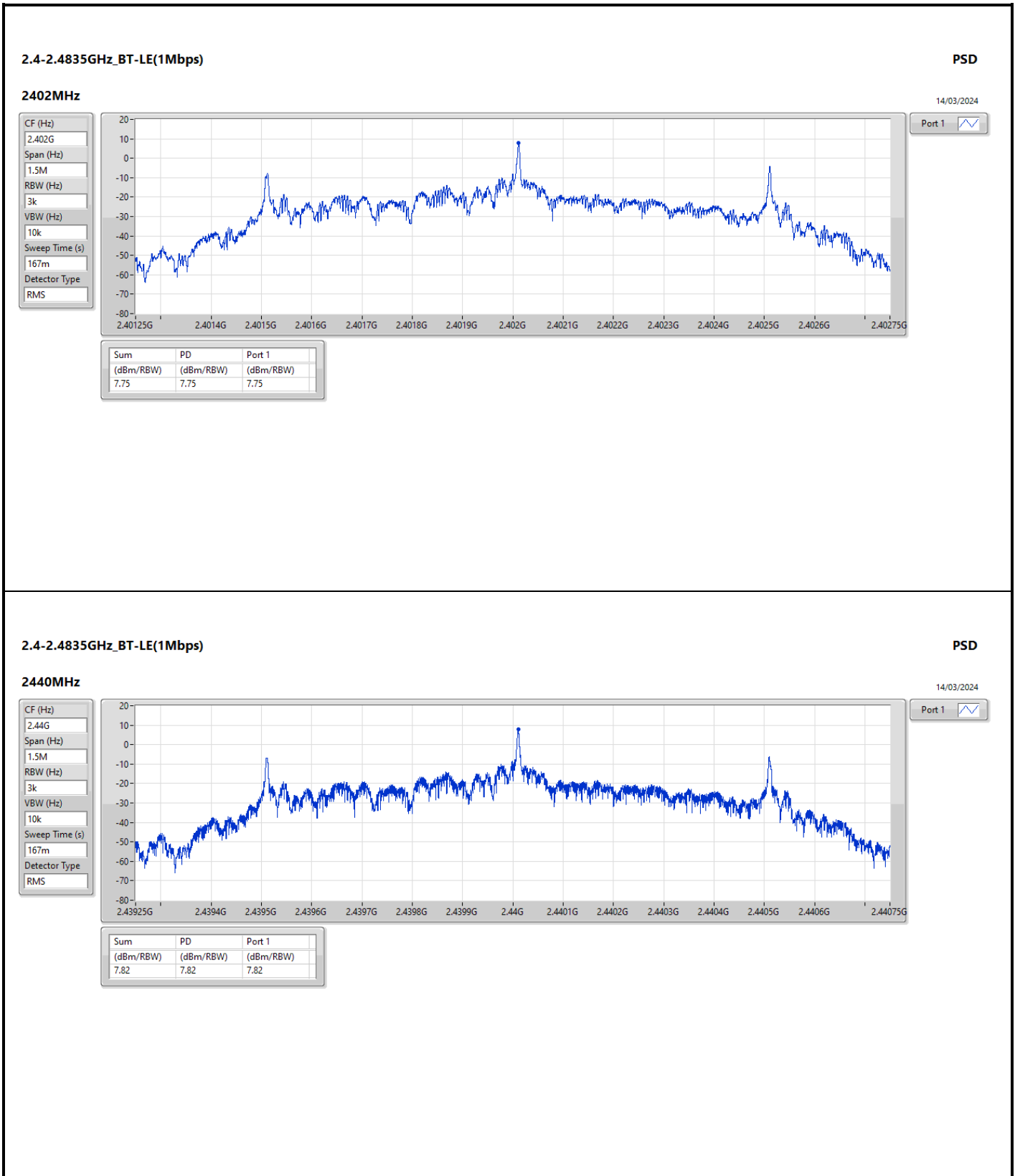

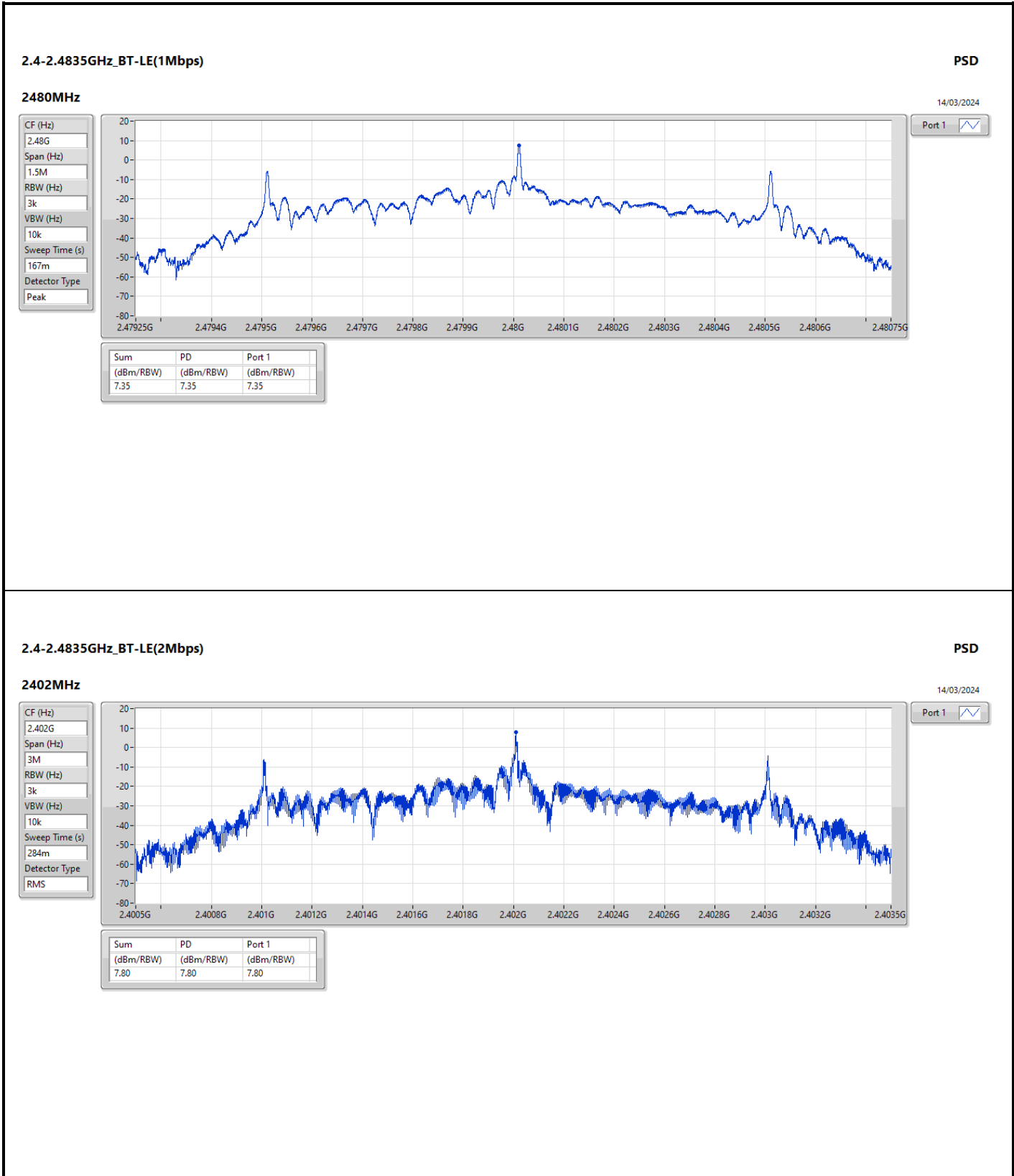

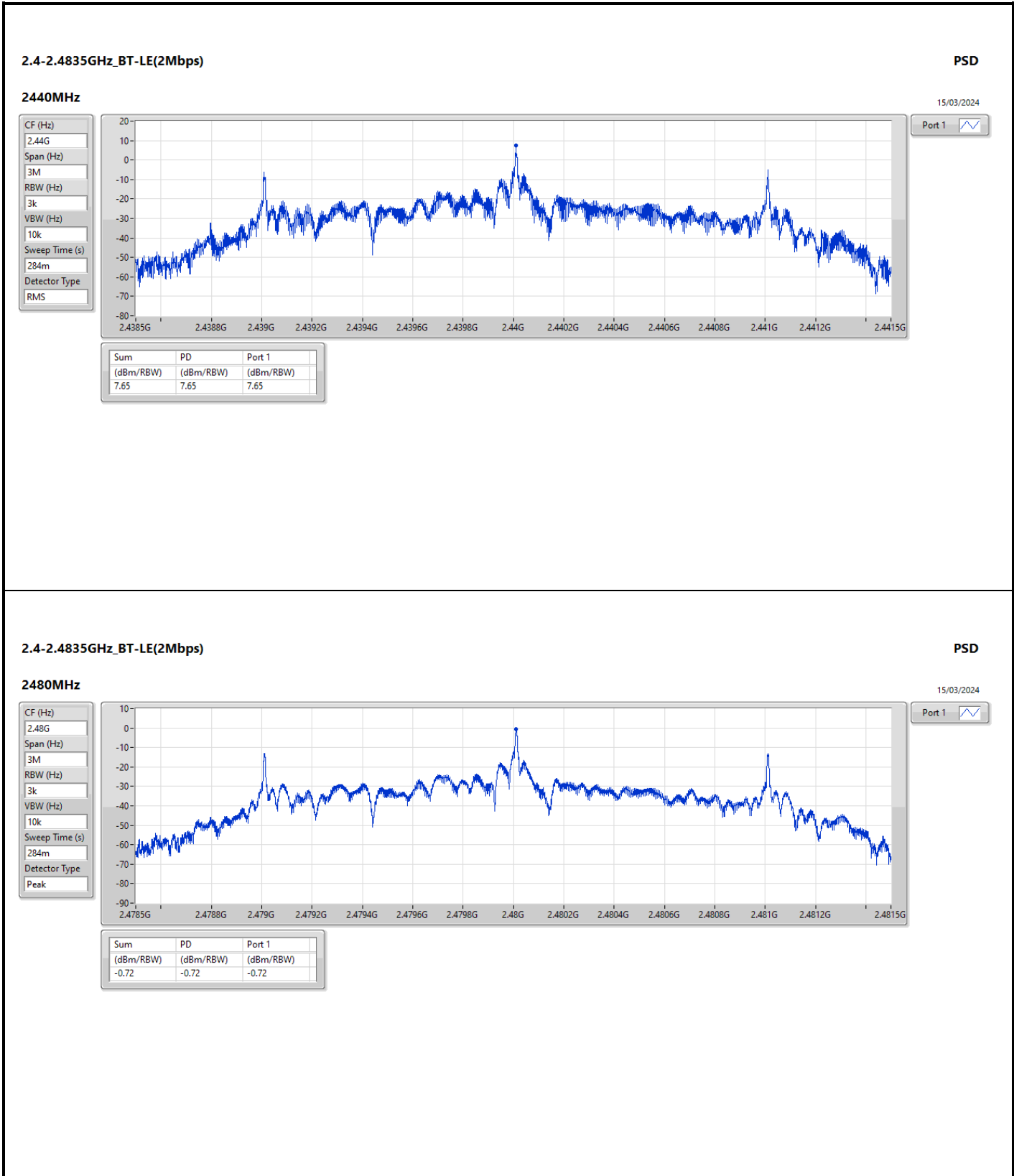



Summary

Mode	Result	Ref (Hz)	Ref (dBm)	Limit (dBm)	Freq (Hz)	Level (dBm)	Freq (Hz)	Level (dBm)	Freq (Hz)	Level (dBm)	Freq (Hz)	Level (dBm)	Freq (Hz)	Level (dBm)	Port
2.4-2.4835GHz	-	-	-	-	-	-	-	-	-	-	-	-	-	-	-
BT-LE(1Mbps)	Pass	2.402G	11.43	-18.57	1.76665G	-53.61	2.39992G	-40.41	2.4G	-41.31	2.5021G	-52.65	21.66771G	-47.39	1
BT-LE(2Mbps)	Pass	2.402G	15.60	-14.40	2.0933G	-53.66	2.4G	-15.72	2.4G	-15.03	2.50026G	-51.85	21.92079G	-47.00	1

Result

Mode	Result	Ref (Hz)	Ref (dBm)	Limit (dBm)	Freq (Hz)	Level (dBm)	Freq (Hz)	Level (dBm)	Freq (Hz)	Level (dBm)	Freq (Hz)	Level (dBm)	Freq (Hz)	Level (dBm)	Port
BT-LE(1Mbps)	-	-	-	-	-	-	-	-	-	-	-	-	-	-	-
2402MHz	Pass	2.402G	11.43	-18.57	1.76665G	-53.61	2.39992G	-40.41	2.4G	-41.31	2.5021G	-52.65	21.66771G	-47.39	1
2440MHz	Pass	2.402G	11.43	-18.57	2.02398G	-53.62	2.39852G	-52.19	2.4G	-57.34	2.50066G	-52.17	21.99953G	-47.06	1
2480MHz	Pass	2.402G	11.43	-18.57	2.14853G	-53.20	2.39428G	-52.10	2.4G	-57.27	2.50318G	-52.30	21.75207G	-48.54	1
BT-LE(2Mbps)	-	-	-	-	-	-	-	-	-	-	-	-	-	-	-
2402MHz	Pass	2.402G	15.60	-14.40	2.0933G	-53.66	2.4G	-15.72	2.4G	-15.03	2.50026G	-51.85	21.92079G	-47.00	1
2440MHz	Pass	2.402G	15.60	-14.40	1.74198G	-53.80	2.39052G	-51.80	2.4G	-55.11	2.5027G	-52.49	21.99109G	-48.43	1
2480MHz	Pass	2.402G	15.60	-14.40	1.84773G	-54.21	2.39252G	-51.64	2.4G	-56.81	2.50002G	-51.70	21.90954G	-48.34	1

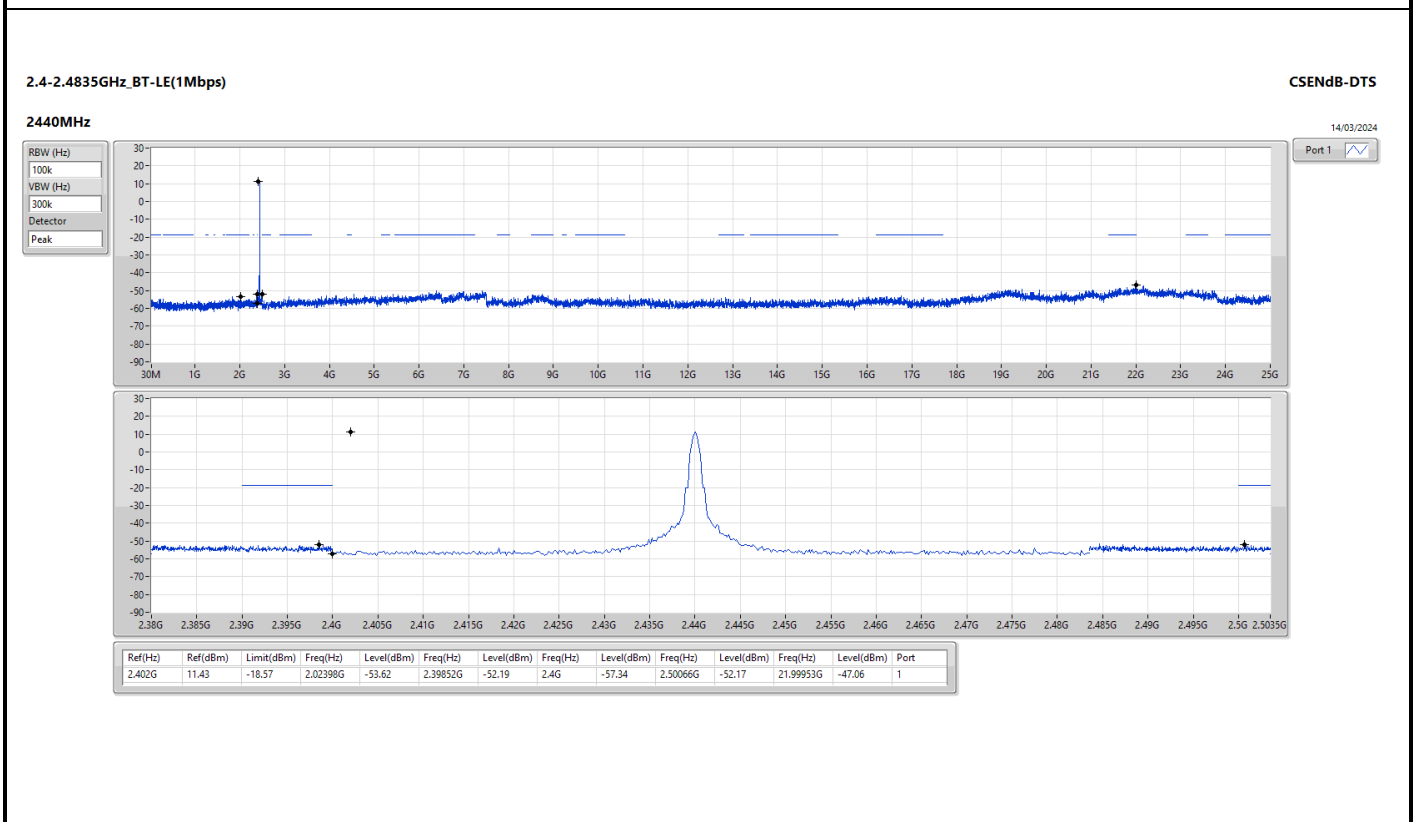
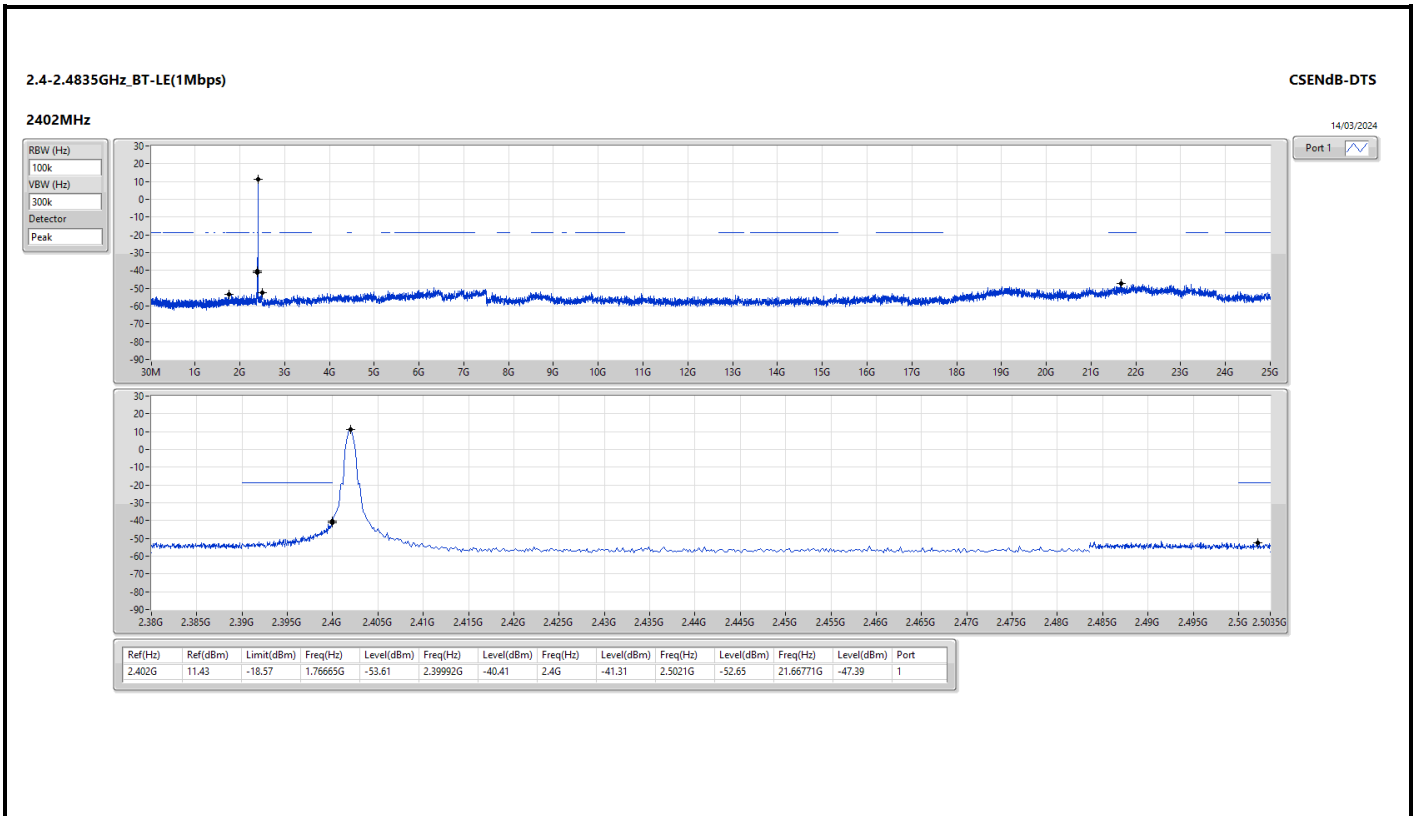

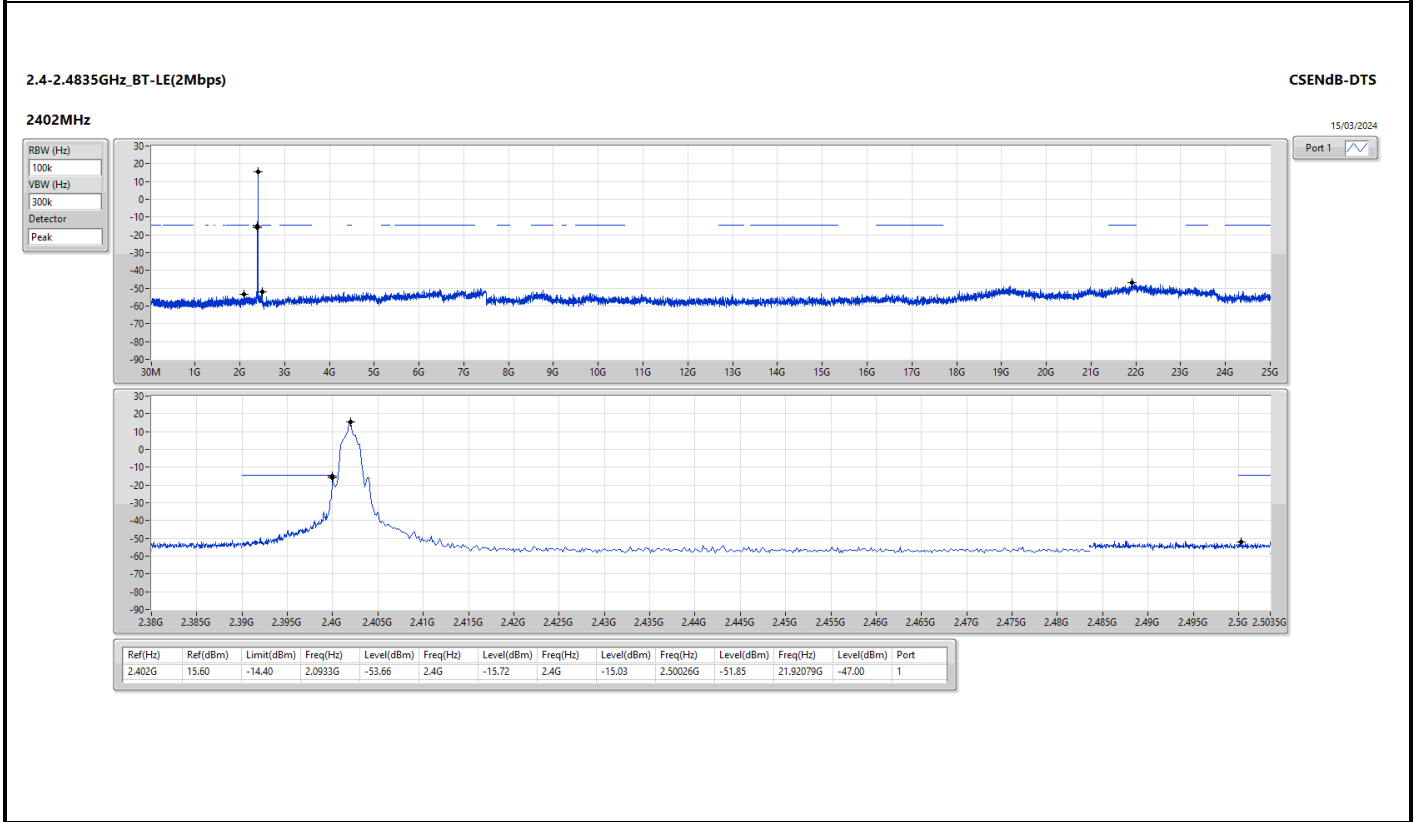
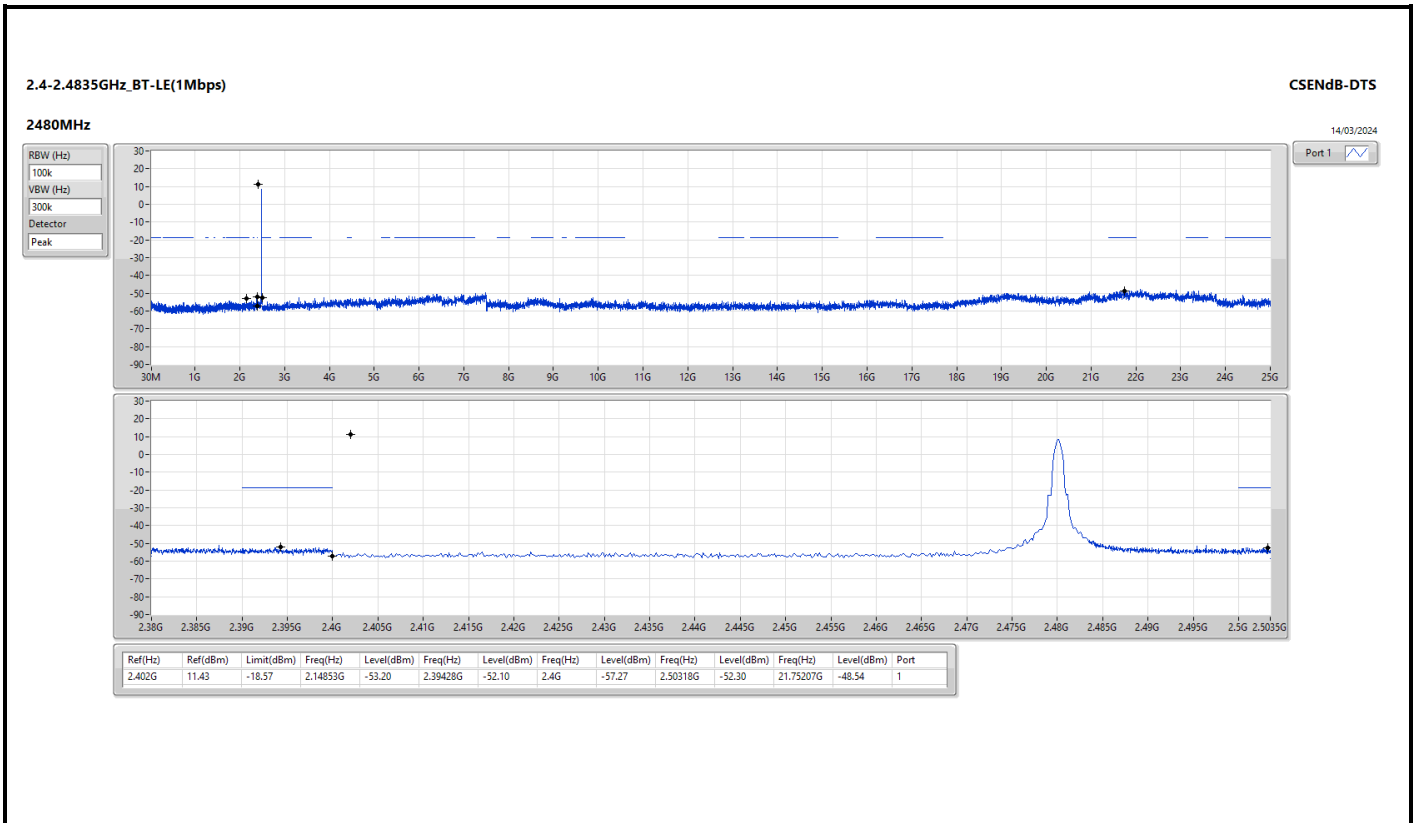



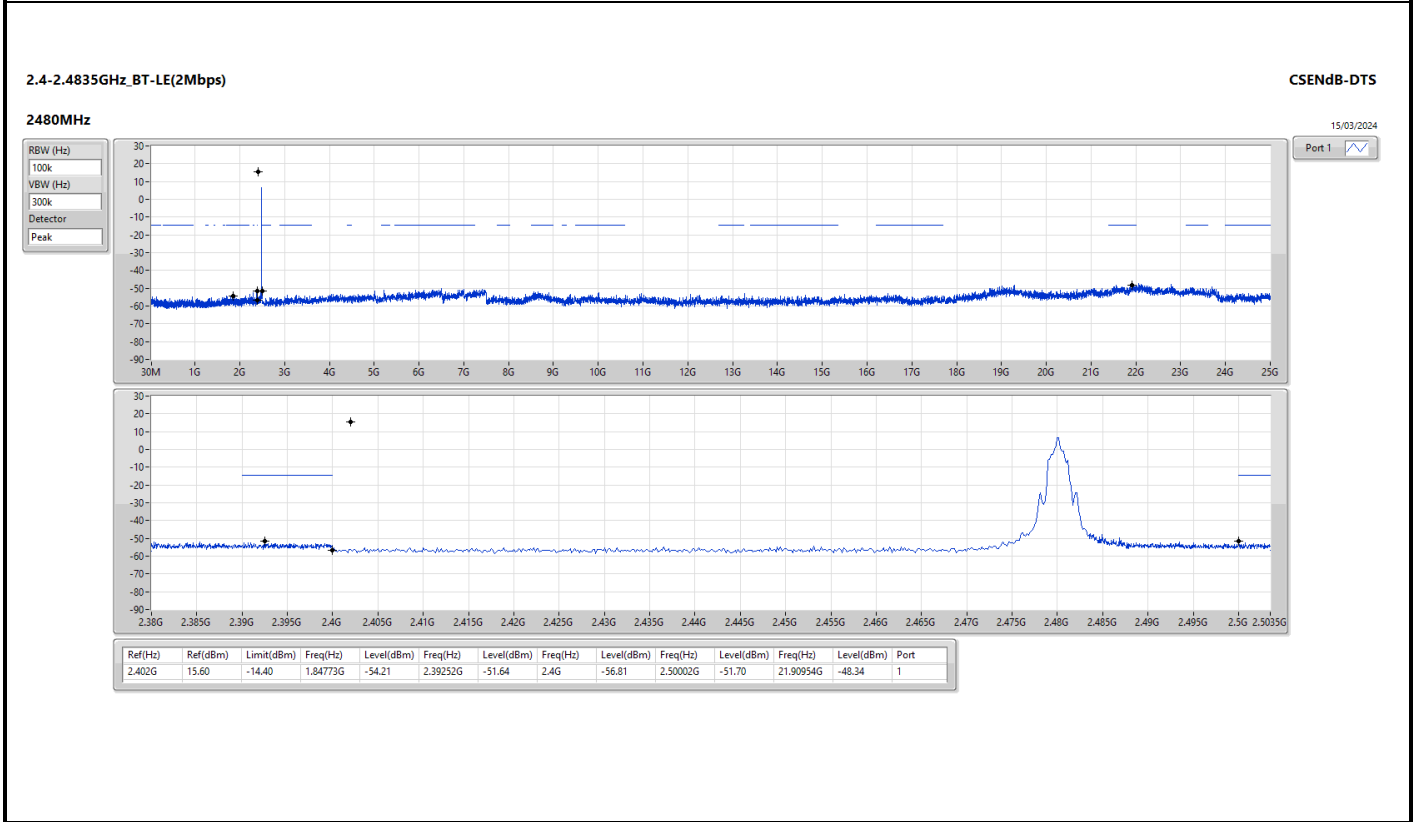
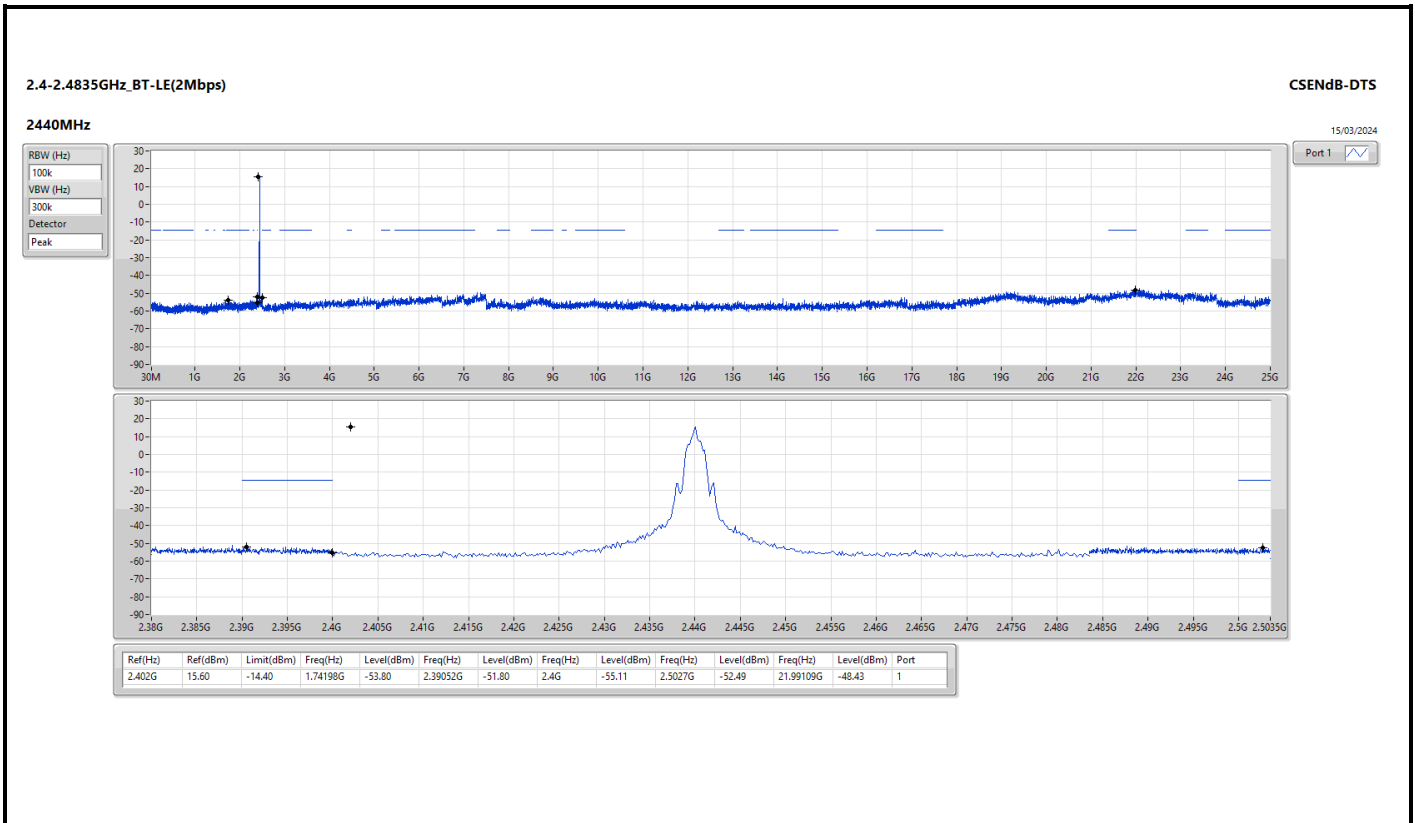



**Summary**

Mode	Result	Type	Freq (Hz)	Level (dBuV/m)	Limit (dBuV/m)	Margin (dB)	Condition
Mode 15	Pass	PK	101.78M	39.47	43.50	-4.03	Horizontal

Mode 15

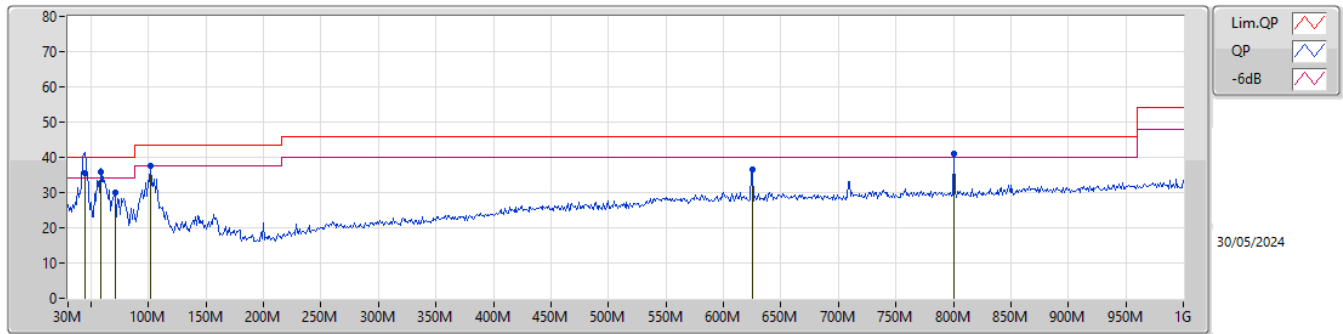

Type	Freq (Hz)	Level (dBuV/m)	Limit (dBuV/m)	Margin (dB)	Factor (dB/m)	Dist (m)	Condition	Azimuth (°)	Height (m)	Comment	Raw (dBuV/m)	AF (dB/m)	CL (dB)	PA (dB)
QP	44.55M	35.45	40.00	-4.55	-13.75	3	Vertical	32	1.00	-	49.20	16.63	1.22	31.60
QP	58.13M	35.81	40.00	-4.19	-17.62	3	Vertical	358	1.00	"Worst"	53.43	12.68	1.37	31.67
PK	70.74M	30.16	40.00	-9.84	-17.69	3	Vertical	120	1.00	-	47.85	12.51	1.50	31.70
PK	101.78M	37.71	43.50	-5.79	-12.93	3	Vertical	188	1.50	-	50.64	17.04	1.77	31.74
PK	625.58M	36.65	46.00	-9.35	-2.92	3	Vertical	193	1.50	-	39.57	24.64	4.72	32.28
PK	800.18M	40.98	46.00	-5.02	-1.04	3	Vertical	182	1.00	-	42.02	25.87	5.43	32.34

Mode 15

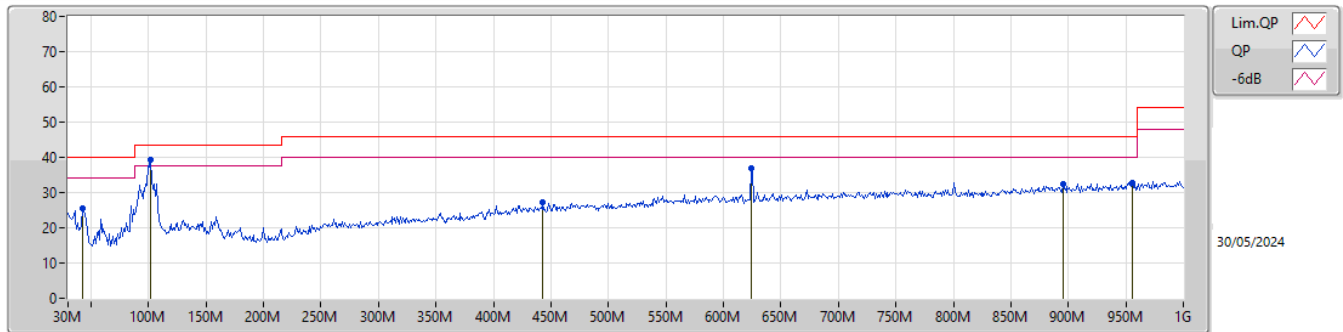

Type	Freq (Hz)	Level (dBuV/m)	Limit (dBuV/m)	Margin (dB)	Factor (dB/m)	Dist (m)	Condition	Azimuth (°)	Height (m)	Comment	Raw (dBuV/m)	AF (dB/m)	CL (dB)	PA (dB)
PK	42.61M	25.66	40.00	-14.34	-12.77	3	Horizontal	267	1.50	-	38.43	17.61	1.20	31.58
PK	101.78M	39.47	43.50	-4.03	-12.93	3	Horizontal	258	1.50	"Worst"	52.40	17.04	1.77	31.74
PK	443.22M	27.26	46.00	-18.74	-5.67	3	Horizontal	106	1.00	-	32.93	22.45	3.91	32.03
PK	624.61M	36.99	46.00	-9.01	-2.92	3	Horizontal	253	1.50	-	39.91	24.64	4.71	32.27
PK	895.24M	32.58	46.00	-13.42	-0.14	3	Horizontal	144	1.00	-	32.72	26.40	5.82	32.36
PK	955.38M	32.74	46.00	-13.26	0.39	3	Horizontal	75	1.00	-	32.35	26.70	6.00	32.31



Summary

Mode	Result	Type	Freq (Hz)	Level (dBuV/m)	Limit (dBuV/m)	Margin (dB)	Dist (m)	Condition	Azimuth (°)	Height (m)	Comments
2.4-2.4835GHz	-	-	-	-	-	-	-	-	-	-	-
BT-LE(2Mbps)	Pass	AV	2.4835G	53.65	54.00	-0.35	3	Horizontal	49	2.68	-

2.4-2.4835GHz\_BT-LE(1Mbps)

2402MHz\_TX

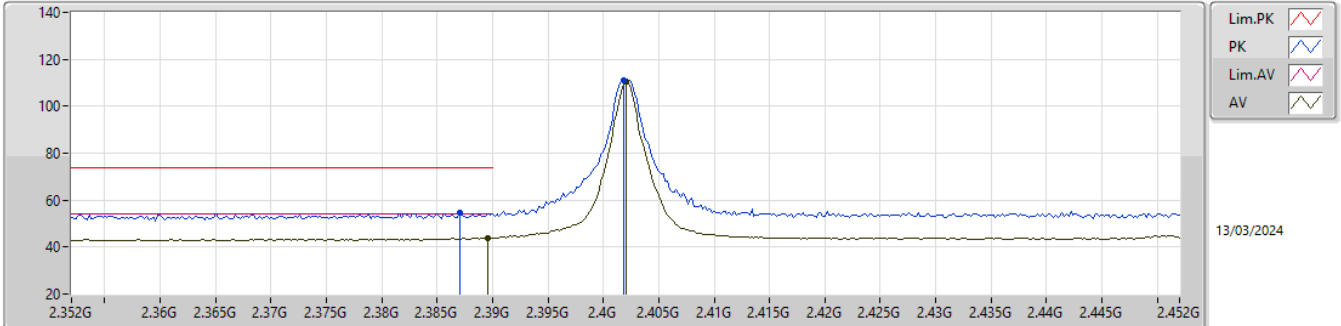

EUT\_X\_1TX  
Setting 200  
04-E-G-5

Type	Freq (Hz)	Level (dBuV/m)	Limit (dBuV/m)	Margin (dB)	Raw (dBuV)	Dist (m)	Condition	Azimuth (°)	Height (m)	Comment	AF (dB)	CL (dB)	PA (dB)
PK	2.387G	54.47	74.00	-19.53	23.73	3	Vertical	321	2.20	-	27.40	3.34	-
AV	2.3896G	43.86	54.00	-10.14	13.11	3	Vertical	321	2.20	-	27.40	3.35	-
PK	2.4018G	111.22	Inf	-Inf	80.37	3	Vertical	321	2.20	-	27.50	3.35	-
AV	2.402G	110.35	Inf	-Inf	79.50	3	Vertical	321	2.20	-	27.50	3.35	-

2.4-2.4835GHz\_BT-LE(1Mbps)

2402MHz\_TX

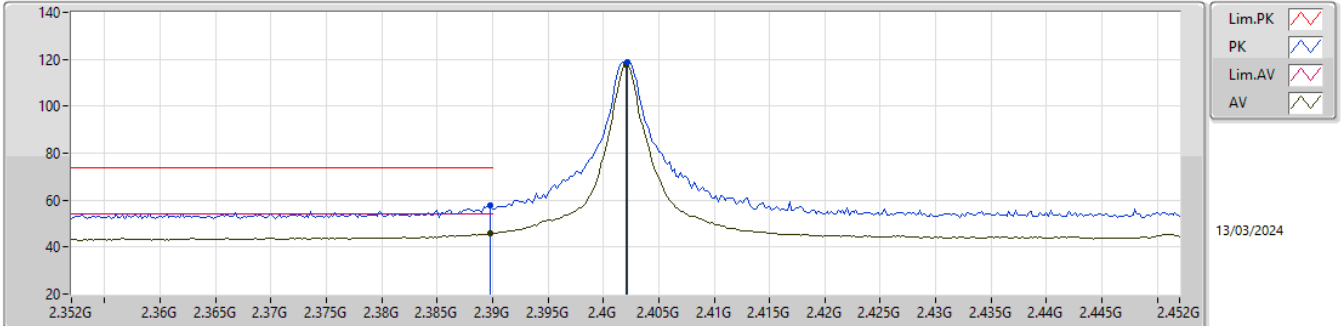

EUT\_X\_1TX  
Setting 200  
04-E-G-5

Type	Freq (Hz)	Level (dBuV/m)	Limit (dBuV/m)	Margin (dB)	Raw (dBuV)	Dist (m)	Condition	Azimuth (°)	Height (m)	Comment	AF (dB)	CL (dB)	PA (dB)
PK	2.3898G	57.59	74.00	-16.41	26.84	3	Horizontal	328	1.97	-	27.40	3.35	-
AV	2.3898G	45.80	54.00	-8.20	15.05	3	Horizontal	328	1.97	-	27.40	3.35	-
PK	2.4022G	118.64	Inf	-Inf	87.79	3	Horizontal	328	1.97	-	27.50	3.35	-
AV	2.402G	117.82	Inf	-Inf	86.97	3	Horizontal	328	1.97	-	27.50	3.35	-

2.4-2.4835GHz\_BT-LE(1Mbps)

2402MHz\_TX

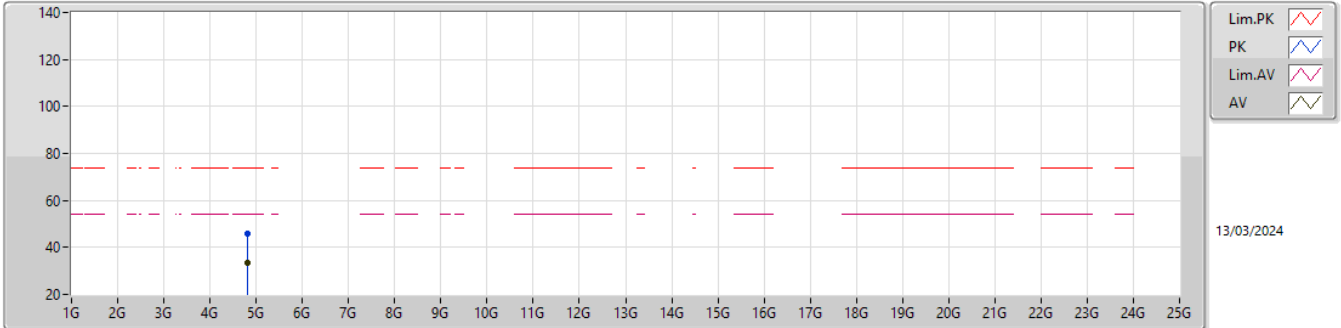

EUT\_X\_1TX  
Setting 200  
04-E-G-5

Type	Freq (Hz)	Level (dBuV/m)	Limit (dBuV/m)	Margin (dB)	Raw (dBuV)	Dist (m)	Condition	Azimuth (°)	Height (m)	Comment	AF (dB)	CL (dB)	PA (dB)
PK	4.79904G	45.74	74.00	-28.26	41.07	3	Vertical	9	2.58	-	32.30	5.65	33.28
AV	4.8063G	33.68	54.00	-20.32	28.99	3	Vertical	9	2.58	-	32.31	5.66	33.28



2.4-2.4835GHz\_BT-LE(1Mbps)

2402MHz\_TX

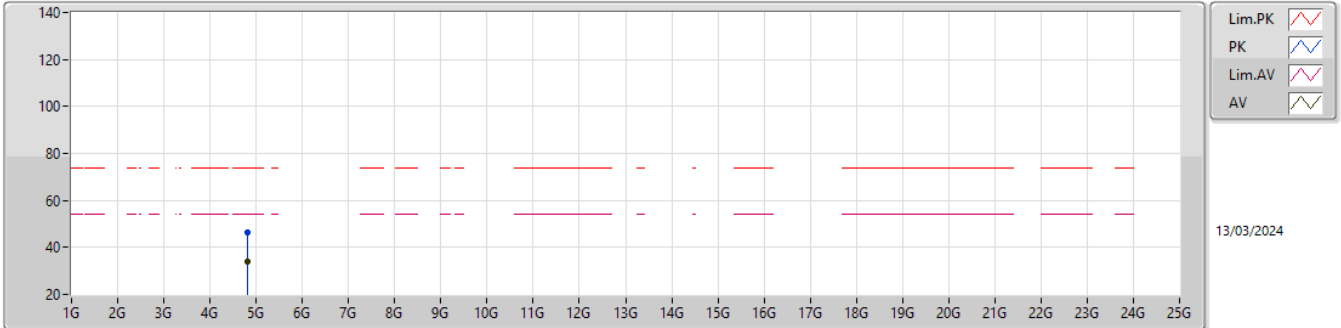

EUT\_X\_1TX  
 Setting 200  
 04-E-G-5

Type	Freq (Hz)	Level (dBuV/m)	Limit (dBuV/m)	Margin (dB)	Raw (dBuV)	Dist (m)	Condition	Azimuth (°)	Height (m)	Comment	AF (dB)	CL (dB)	PA (dB)
PK	4.80304G	46.21	74.00	-27.79	41.53	3	Horizontal	338	1.80	-	32.31	5.65	33.28
AV	4.80856G	33.76	54.00	-20.24	29.06	3	Horizontal	338	1.80	-	32.32	5.66	33.28

2.4-2.4835GHz\_BT-LE(1Mbps)

2440MHz\_TX

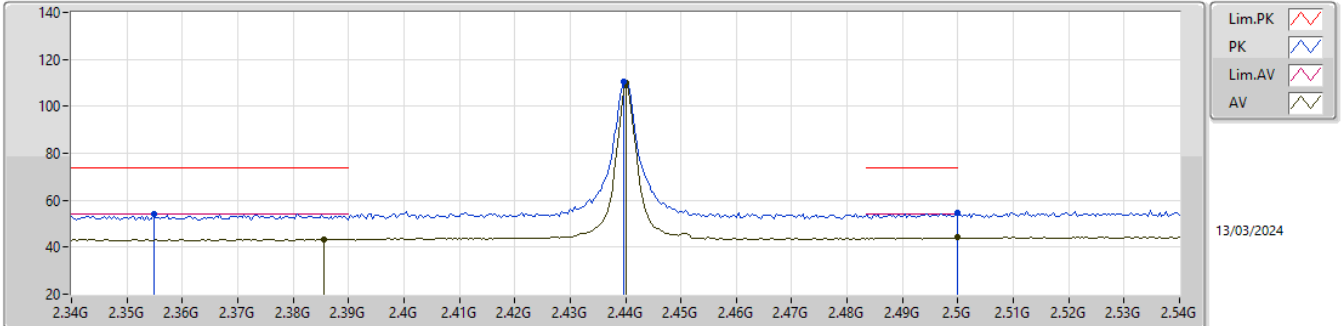

EUT\_X\_1TX  
Setting 200  
04-E-G-5

Type	Freq (Hz)	Level (dBuV/m)	Limit (dBuV/m)	Margin (dB)	Raw (dBuV)	Dist (m)	Condition	Azimuth (°)	Height (m)	Comment	AF (dB)	CL (dB)	PA (dB)
PK	2.3548G	54.00	74.00	-20.00	23.27	3	Vertical	333	2.70	-	27.40	3.33	-
AV	2.3856G	43.46	54.00	-10.54	12.72	3	Vertical	333	2.70	-	27.40	3.34	-
PK	2.4396G	110.77	Inf	-Inf	79.80	3	Vertical	333	2.70	-	27.60	3.37	-
AV	2.44G	109.96	Inf	-Inf	78.99	3	Vertical	333	2.70	-	27.60	3.37	-
PK	2.5G	54.41	74.00	-19.59	23.30	3	Vertical	333	2.70	-	27.70	3.41	-
AV	2.5G	44.06	54.00	-9.94	12.95	3	Vertical	333	2.70	-	27.70	3.41	-

2.4-2.4835GHz\_BT-LE(1Mbps)

2440MHz\_TX

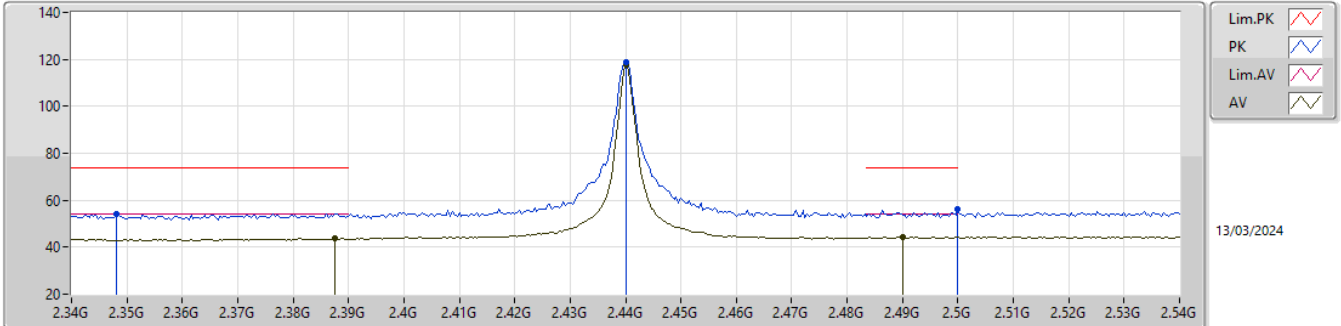

EUT\_X\_1TX  
Setting 200  
04-E-G-5

Type	Freq (Hz)	Level (dBuV/m)	Limit (dBuV/m)	Margin (dB)	Raw (dBuV)	Dist (m)	Condition	Azimuth (°)	Height (m)	Comment	AF (dB)	CL (dB)	PA (dB)
PK	2.348G	54.36	74.00	-19.64	23.63	3	Horizontal	324	2.37	-	27.40	3.33	-
AV	2.3876G	43.58	54.00	-10.42	12.83	3	Horizontal	324	2.37	-	27.40	3.35	-
PK	2.44G	118.71	Inf	-Inf	87.74	3	Horizontal	324	2.37	-	27.60	3.37	-
AV	2.44G	117.92	Inf	-Inf	86.95	3	Horizontal	324	2.37	-	27.60	3.37	-
PK	2.5G	56.09	74.00	-17.91	24.98	3	Horizontal	324	2.37	-	27.70	3.41	-
AV	2.49G	44.42	54.00	-9.58	13.32	3	Horizontal	324	2.37	-	27.70	3.40	-

2.4-2.4835GHz\_BT-LE(1Mbps)

2440MHz\_TX

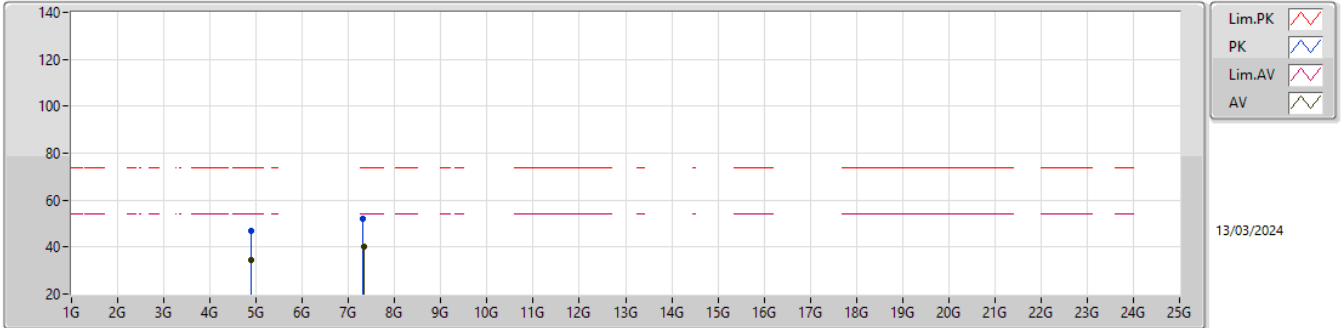

EUT\_X\_1TX  
Setting 200  
04-E-G-5

Type	Freq (Hz)	Level (dBuV/m)	Limit (dBuV/m)	Margin (dB)	Raw (dBuV)	Dist (m)	Condition	Azimuth (°)	Height (m)	Comment	AF (dB)	CL (dB)	PA (dB)
PK	4.88236G	46.70	74.00	-27.30	41.70	3	Vertical	162	2.32	-	32.53	5.72	33.25
AV	4.87874G	34.26	54.00	-19.74	29.28	3	Vertical	162	2.32	-	32.51	5.72	33.25
PK	7.31814G	52.05	74.00	-21.95	41.83	3	Vertical	247	1.39	-	37.20	7.12	34.10
AV	7.32428G	40.36	54.00	-13.64	30.13	3	Vertical	247	1.39	-	37.20	7.13	34.10

2.4-2.4835GHz\_BT-LE(1Mbps)

2440MHz\_TX

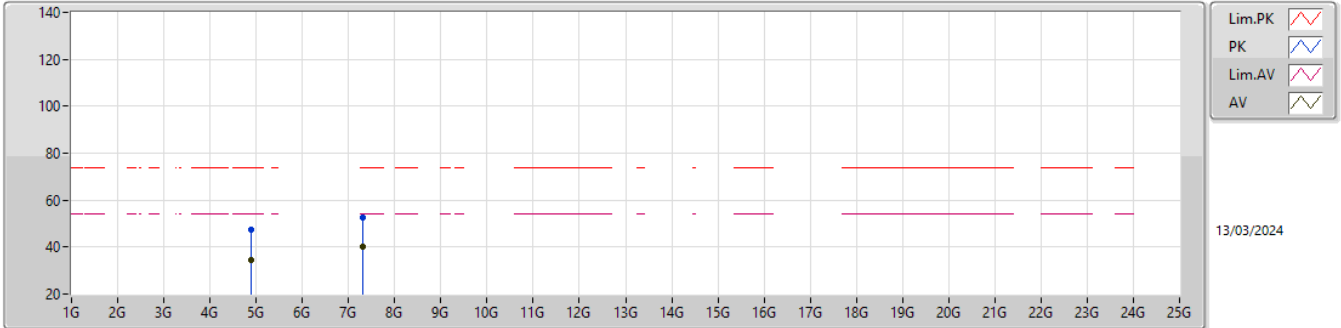

EUT\_X\_1TX  
Setting 200  
04-E-G-5

Type	Freq (Hz)	Level (dBuV/m)	Limit (dBuV/m)	Margin (dB)	Raw (dBuV)	Dist (m)	Condition	Azimuth (°)	Height (m)	Comment	AF (dB)	CL (dB)	PA (dB)
PK	4.88118G	47.22	74.00	-26.78	42.23	3	Horizontal	352	2.06	-	32.52	5.72	33.25
AV	4.88074G	34.56	54.00	-19.44	29.57	3	Horizontal	352	2.06	-	32.52	5.72	33.25
PK	7.31794G	52.49	74.00	-21.51	42.27	3	Horizontal	87	2.46	-	37.20	7.12	34.10
AV	7.32036G	40.27	54.00	-13.73	30.04	3	Horizontal	87	2.46	-	37.20	7.13	34.10

2.4-2.4835GHz\_BT-LE(1Mbps)

2478MHz\_TX

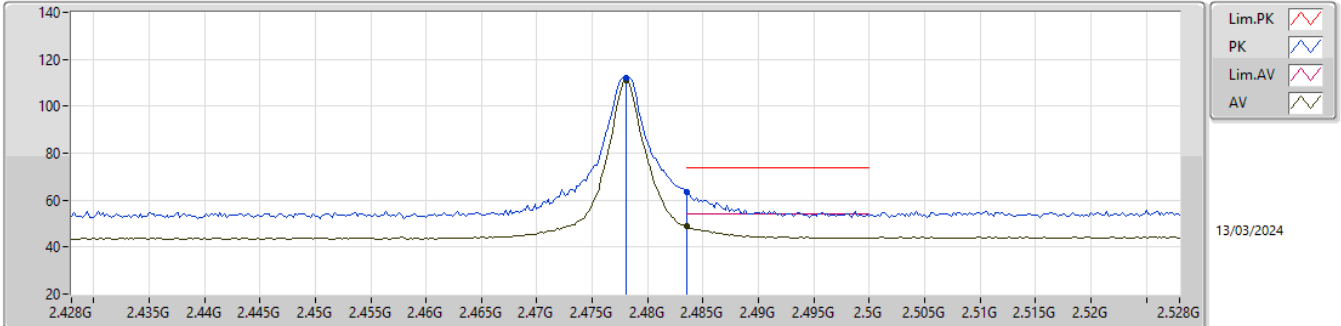

EUT\_X\_1TX  
 Setting 180  
 04-E-R-7

Type	Freq (Hz)	Level (dBuV/m)	Limit (dBuV/m)	Margin (dB)	Raw (dBuV)	Dist (m)	Condition	Azimuth (°)	Height (m)	Comment	AF (dB)	CL (dB)	PA (dB)
PK	2.478G	112.15	Inf	-Inf	81.16	3	Vertical	353	2.19	-	27.60	3.39	-
AV	2.478G	111.27	Inf	-Inf	80.28	3	Vertical	353	2.19	-	27.60	3.39	-
PK	2.4835G	63.25	74.00	-10.75	32.21	3	Vertical	353	2.19	-	27.64	3.40	-
AV	2.4835G	49.00	54.00	-5.00	17.96	3	Vertical	353	2.19	-	27.64	3.40	-

2.4-2.4835GHz\_BT-LE(1Mbps)

2478MHz\_TX

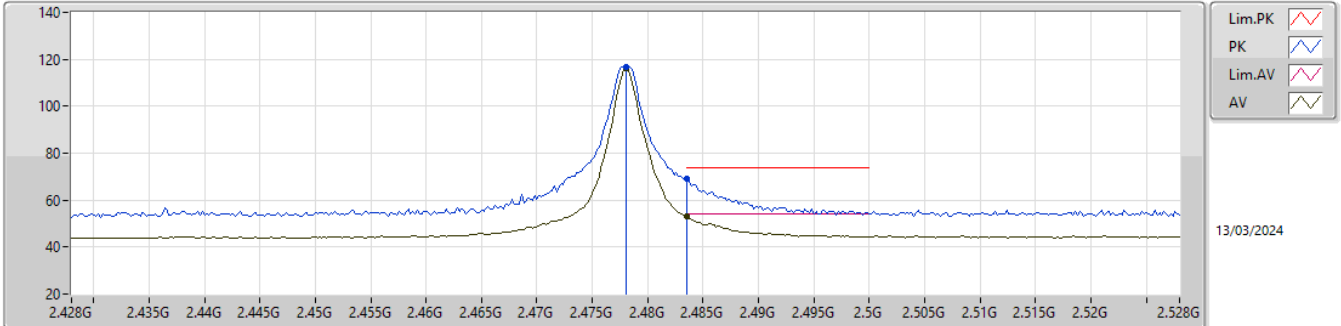

EUT\_X\_1TX  
Setting 180  
04-E-R-7

Type	Freq (Hz)	Level (dBuV/m)	Limit (dBuV/m)	Margin (dB)	Raw (dBuV)	Dist (m)	Condition	Azimuth (°)	Height (m)	Comment	AF (dB)	CL (dB)	PA (dB)
PK	2.478G	116.98	Inf	-Inf	85.99	3	Horizontal	35	2.75	-	27.60	3.39	-
AV	2.478G	116.07	Inf	-Inf	85.08	3	Horizontal	35	2.75	-	27.60	3.39	-
PK	2.4835G	69.20	74.00	-4.80	38.16	3	Horizontal	35	2.75	-	27.64	3.40	-
AV	2.4835G	52.92	54.00	-1.08	21.88	3	Horizontal	35	2.75	-	27.64	3.40	-

2.4-2.4835GHz\_BT-LE(1Mbps)

2480MHz\_TX

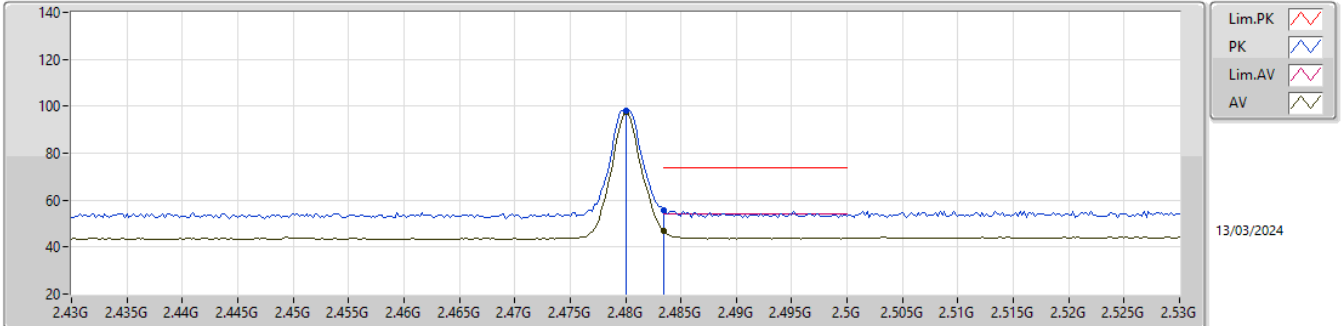

EUT\_X\_1TX  
Setting 90  
04-E-G-5

Type	Freq (Hz)	Level (dBuV/m)	Limit (dBuV/m)	Margin (dB)	Raw (dBuV)	Dist (m)	Condition	Azimuth (°)	Height (m)	Comment	AF (dB)	CL (dB)	PA (dB)
PK	2.48G	98.18	Inf	-Inf	67.19	3	Vertical	314	2.35	-	27.60	3.39	-
AV	2.48G	97.38	Inf	-Inf	66.39	3	Vertical	314	2.35	-	27.60	3.39	-
PK	2.4835G	55.87	74.00	-18.13	24.83	3	Vertical	314	2.35	-	27.64	3.40	-
AV	2.4835G	46.77	54.00	-7.23	15.73	3	Vertical	314	2.35	-	27.64	3.40	-



2.4-2.4835GHz\_BT-LE(1Mbps)

2480MHz\_TX

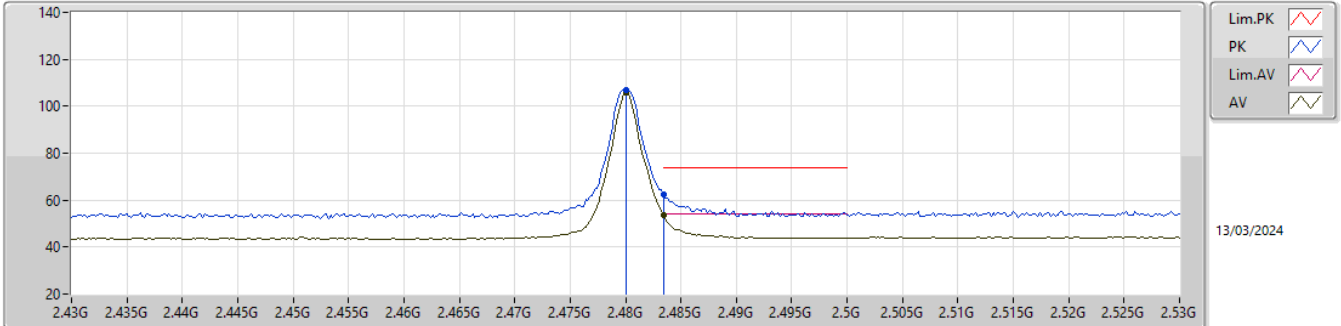

EUT\_X\_1TX  
 Setting 90  
 04-E-G-5

Type	Freq (Hz)	Level (dBuV/m)	Limit (dBuV/m)	Margin (dB)	Raw (dBuV)	Dist (m)	Condition	Azimuth (°)	Height (m)	Comment	AF (dB)	CL (dB)	PA (dB)
PK	2.48G	106.81	Inf	-Inf	75.82	3	Horizontal	321	2.06	-	27.60	3.39	-
AV	2.48G	106.00	Inf	-Inf	75.01	3	Horizontal	321	2.06	-	27.60	3.39	-
PK	2.4835G	62.17	74.00	-11.83	31.13	3	Horizontal	321	2.06	-	27.64	3.40	-
AV	2.4835G	53.65	54.00	-0.35	22.61	3	Horizontal	321	2.06	-	27.64	3.40	-

2.4-2.4835GHz\_BT-LE(1Mbps)

2480MHz\_TX

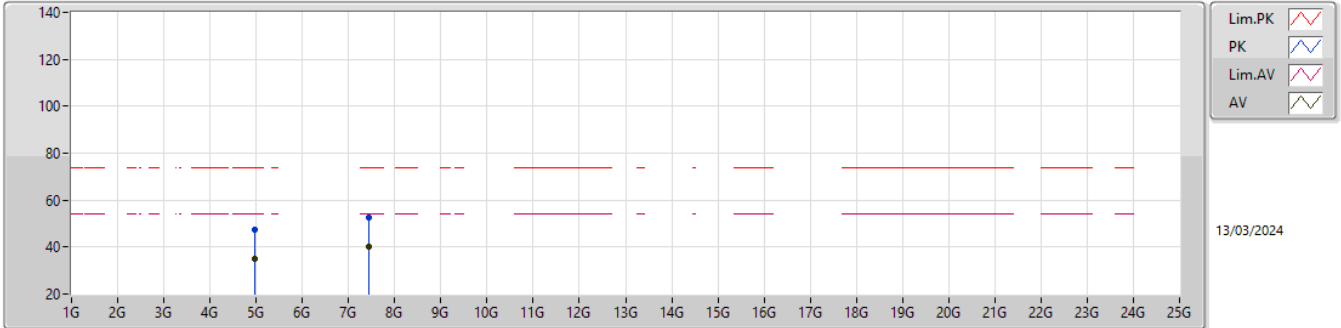

EUT\_X\_1TX  
Setting 90  
04-E-G-5

Type	Freq (Hz)	Level (dBuV/m)	Limit (dBuV/m)	Margin (dB)	Raw (dBuV)	Dist (m)	Condition	Azimuth (°)	Height (m)	Comment	AF (dB)	CL (dB)	PA (dB)
PK	4.96334G	47.40	74.00	-26.60	42.12	3	Vertical	352	2.54	-	32.70	5.80	33.22
AV	4.96312G	35.23	54.00	-18.77	29.95	3	Vertical	352	2.54	-	32.70	5.80	33.22
PK	7.4449G	52.82	74.00	-21.18	42.55	3	Vertical	209	2.71	-	37.20	7.22	34.15
AV	7.44338G	40.42	54.00	-13.58	30.15	3	Vertical	209	2.71	-	37.20	7.22	34.15

2.4-2.4835GHz\_BT-LE(1Mbps)

2480MHz\_TX

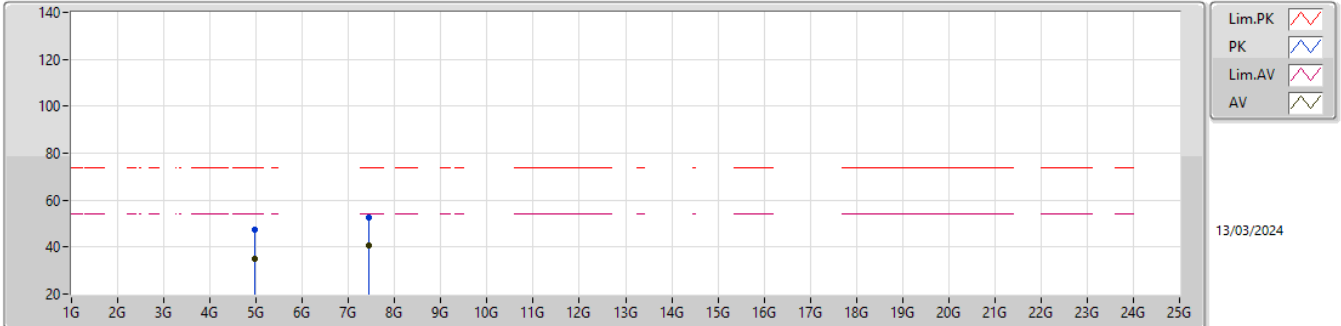

EUT\_X\_1TX  
Setting 90  
04-E-G-5

Type	Freq (Hz)	Level (dBuV/m)	Limit (dBuV/m)	Margin (dB)	Raw (dBuV)	Dist (m)	Condition	Azimuth (°)	Height (m)	Comment	AF (dB)	CL (dB)	PA (dB)
PK	4.96488G	47.46	74.00	-26.54	42.18	3	Horizontal	292	1.45	-	32.70	5.80	33.22
AV	4.96424G	35.15	54.00	-18.85	29.87	3	Horizontal	292	1.45	-	32.70	5.80	33.22
PK	7.4439G	52.68	74.00	-21.32	42.41	3	Horizontal	261	2.67	-	37.20	7.22	34.15
AV	7.43612G	40.46	54.00	-13.54	30.19	3	Horizontal	261	2.67	-	37.20	7.21	34.14

2.4-2.4835GHz\_BT-LE(2Mbps)

2402MHz\_TX

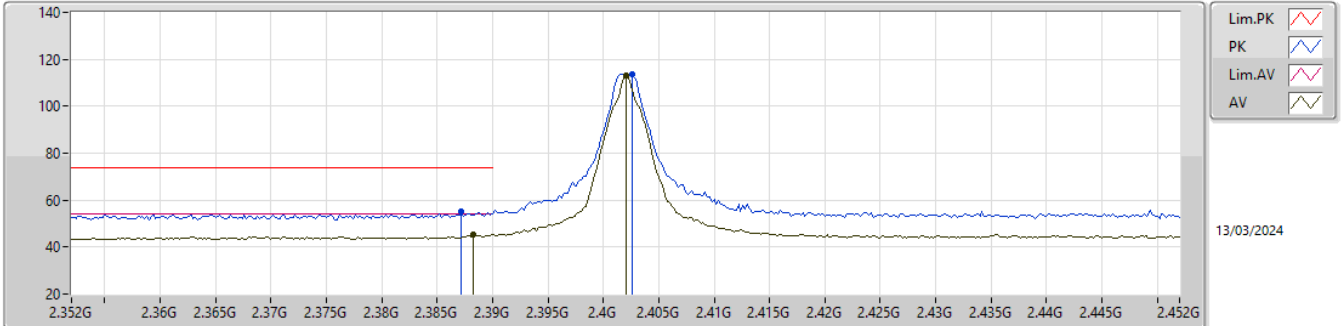

EUT\_X\_1TX  
Setting 200  
04-E-R-7

Type	Freq (Hz)	Level (dBuV/m)	Limit (dBuV/m)	Margin (dB)	Raw (dBuV)	Dist (m)	Condition	Azimuth (°)	Height (m)	Comment	AF (dB)	CL (dB)	PA (dB)
PK	2.3872G	54.99	74.00	-19.01	24.25	3	Vertical	350	2.28	-	27.40	3.34	-
AV	2.3882G	45.30	54.00	-8.70	14.55	3	Vertical	350	2.28	-	27.40	3.35	-
PK	2.4026G	113.68	Inf	-Inf	82.83	3	Vertical	350	2.28	-	27.50	3.35	-
AV	2.402G	112.89	Inf	-Inf	82.04	3	Vertical	350	2.28	-	27.50	3.35	-

2.4-2.4835GHz\_BT-LE(2Mbps)

2402MHz\_TX

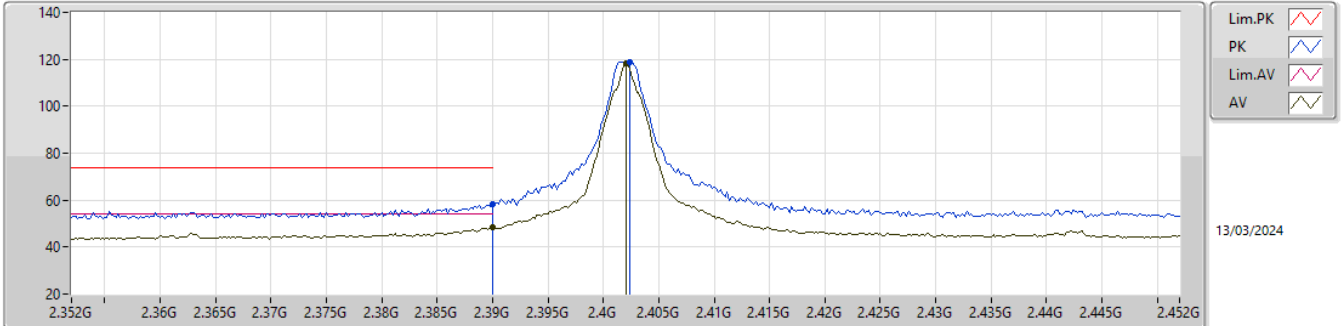

EUT\_X\_1TX  
Setting 200  
04-E-R-7

Type	Freq (Hz)	Level (dBuV/m)	Limit (dBuV/m)	Margin (dB)	Raw (dBuV)	Dist (m)	Condition	Azimuth (°)	Height (m)	Comment	AF (dB)	CL (dB)	PA (dB)
PK	2.39G	58.38	74.00	-15.62	27.63	3	Horizontal	39	2.83	-	27.40	3.35	-
AV	2.39G	48.20	54.00	-5.80	17.45	3	Horizontal	39	2.83	-	27.40	3.35	-
PK	2.4024G	118.99	Inf	-Inf	88.14	3	Horizontal	39	2.83	-	27.50	3.35	-
AV	2.402G	118.27	Inf	-Inf	87.42	3	Horizontal	39	2.83	-	27.50	3.35	-

2.4-2.4835GHz\_BT-LE(2Mbps)

2402MHz\_TX

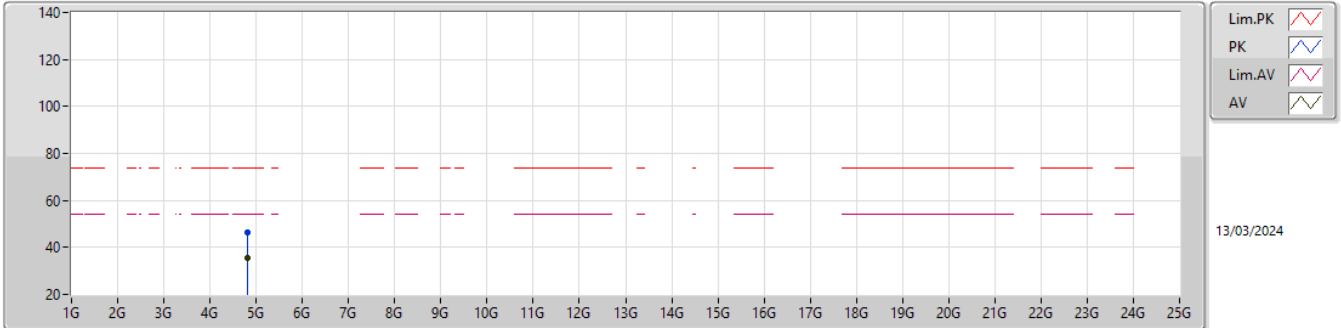

EUT\_X\_1TX  
Setting 200  
04-E-R-7

Type	Freq (Hz)	Level (dBuV/m)	Limit (dBuV/m)	Margin (dB)	Raw (dBuV)	Dist (m)	Condition	Azimuth (°)	Height (m)	Comment	AF (dB)	CL (dB)	PA (dB)
PK	4.7992G	46.33	74.00	-27.67	41.66	3	Vertical	106	1.48	-	32.30	5.65	33.28
AV	4.81864G	35.76	54.00	-18.24	31.03	3	Vertical	106	1.48	-	32.34	5.67	33.28

2.4-2.4835GHz\_BT-LE(2Mbps)

2402MHz\_TX

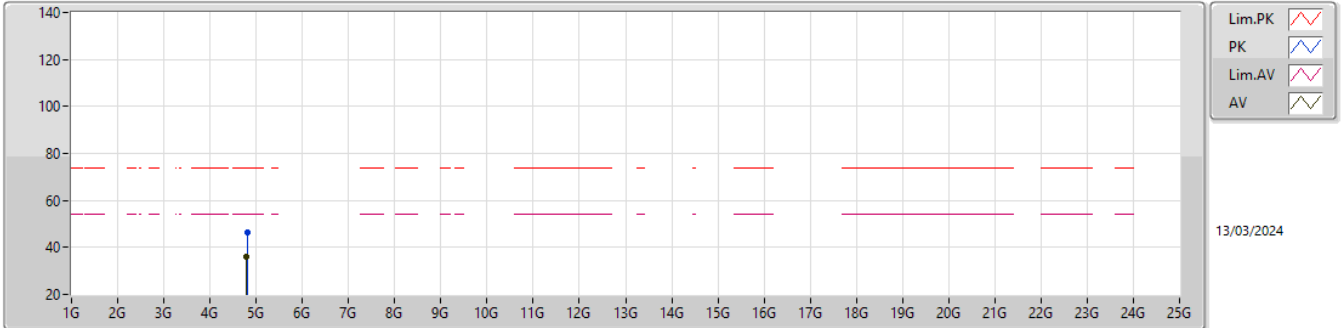

EUT\_X\_1TX  
Setting 200  
04-E-R-7

Type	Freq (Hz)	Level (dBuV/m)	Limit (dBuV/m)	Margin (dB)	Raw (dBuV)	Dist (m)	Condition	Azimuth (°)	Height (m)	Comment	AF (dB)	CL (dB)	PA (dB)
PK	4.81816G	46.17	74.00	-27.83	41.44	3	Horizontal	251	1.19	-	32.34	5.67	33.28
AV	4.79164G	35.91	54.00	-18.09	31.24	3	Horizontal	251	1.19	-	32.32	5.64	33.29

2.4-2.4835GHz\_BT-LE(2Mbps)

2440MHz\_TX

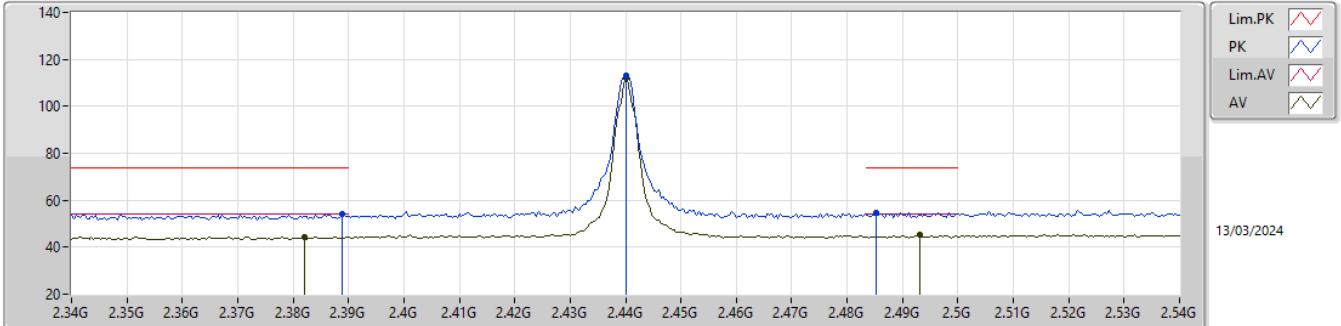

EUT\_X\_1TX  
Setting 200  
04-E-R-7

Type	Freq (Hz)	Level (dBuV/m)	Limit (dBuV/m)	Margin (dB)	Raw (dBuV)	Dist (m)	Condition	Azimuth (°)	Height (m)	Comment	AF (dB)	CL (dB)	PA (dB)
PK	2.3888G	54.23	74.00	-19.77	23.48	3	Vertical	354	1.83	-	27.40	3.35	-
AV	2.382G	44.46	54.00	-9.54	13.72	3	Vertical	354	1.83	-	27.40	3.34	-
PK	2.44G	112.89	Inf	-Inf	81.92	3	Vertical	354	1.83	-	27.60	3.37	-
AV	2.44G	112.10	Inf	-Inf	81.13	3	Vertical	354	1.83	-	27.60	3.37	-
PK	2.4852G	54.79	74.00	-19.21	23.74	3	Vertical	354	1.83	-	27.65	3.40	-
AV	2.4932G	45.14	54.00	-8.86	14.04	3	Vertical	354	1.83	-	27.70	3.40	-



2.4-2.4835GHz\_BT-LE(2Mbps)

2440MHz\_TX

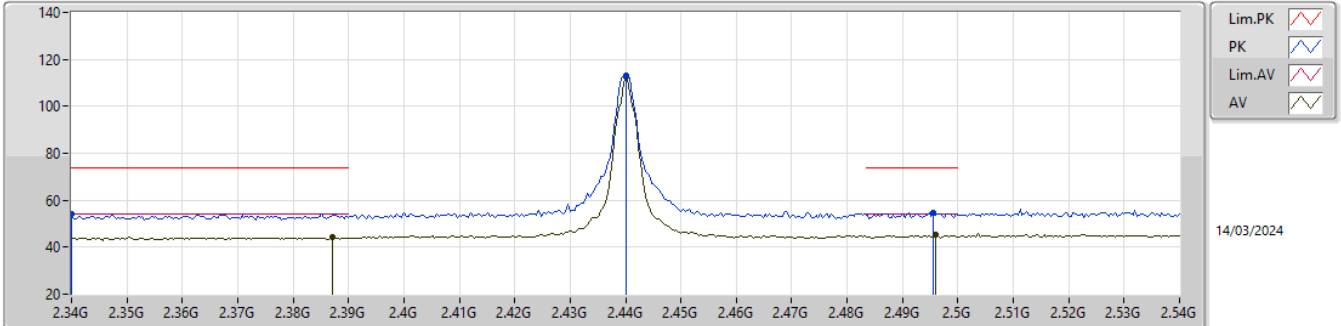

EUT\_X\_1TX  
Setting 200  
04-E-R-7

Type	Freq (Hz)	Level (dBuV/m)	Limit (dBuV/m)	Margin (dB)	Raw (dBuV)	Dist (m)	Condition	Azimuth (°)	Height (m)	Comment	AF (dB)	CL (dB)	PA (dB)
PK	2.34G	54.15	74.00	-19.85	23.42	3	Horizontal	0	1.80	-	27.40	3.33	-
AV	2.3872G	44.49	54.00	-9.51	13.75	3	Horizontal	0	1.80	-	27.40	3.34	-
PK	2.44G	112.24	Inf	-Inf	82.27	3	Horizontal	0	1.80	-	27.60	3.37	-
AV	2.44G	112.48	Inf	-Inf	81.51	3	Horizontal	0	1.80	-	27.60	3.37	-
PK	2.4956G	54.78	74.00	-19.22	23.68	3	Horizontal	0	1.80	-	27.70	3.40	-
AV	2.496G	45.10	54.00	-8.90	14.00	3	Horizontal	0	1.80	-	27.70	3.40	-

2.4-2.4835GHz\_BT-LE(2Mbps)

2440MHz\_TX

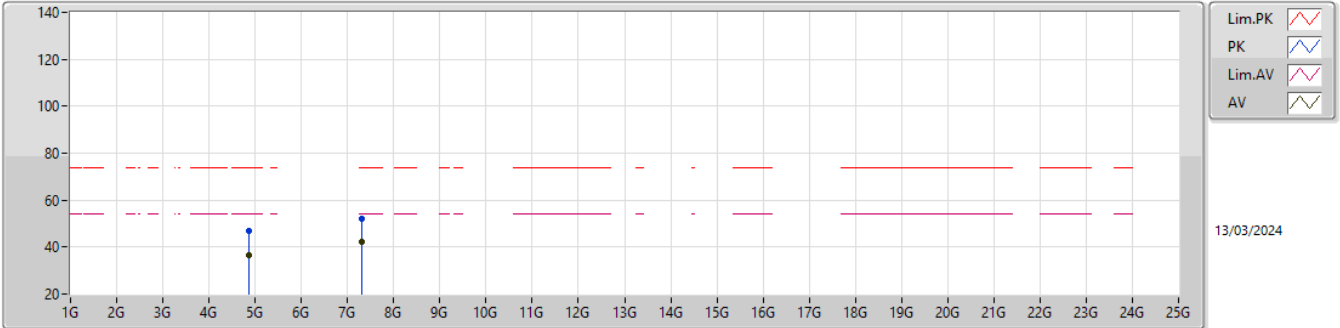

EUT\_X\_1TX  
Setting 200  
04-E-R-7

Type	Freq (Hz)	Level (dBuV/m)	Limit (dBuV/m)	Margin (dB)	Raw (dBuV)	Dist (m)	Condition	Azimuth (°)	Height (m)	Comment	AF (dB)	CL (dB)	PA (dB)
PK	4.87514G	47.00	74.00	-27.00	42.03	3	Vertical	56	2.31	-	32.50	5.72	33.25
AV	4.8752G	36.45	54.00	-17.55	31.48	3	Vertical	56	2.31	-	32.50	5.72	33.25
PK	7.3113G	52.25	74.00	-21.75	42.02	3	Vertical	121	2.49	-	37.20	7.12	34.09
AV	7.31352G	42.41	54.00	-11.59	32.19	3	Vertical	121	2.49	-	37.20	7.12	34.10

2.4-2.4835GHz\_BT-LE(2Mbps)

2440MHz\_TX

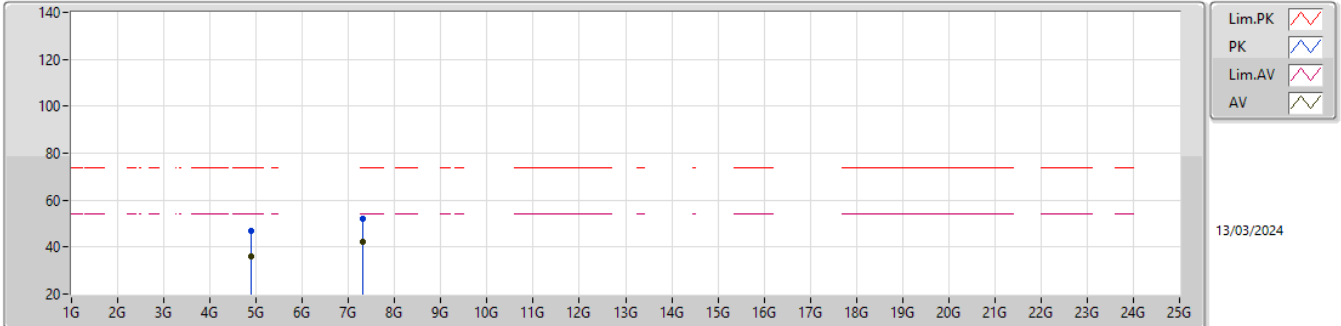

EUT\_X\_1TX  
Setting 200  
04-E-R-7

Type	Freq (Hz)	Level (dBuV/m)	Limit (dBuV/m)	Margin (dB)	Raw (dBuV)	Dist (m)	Condition	Azimuth (°)	Height (m)	Comment	AF (dB)	CL (dB)	PA (dB)
PK	4.8833G	46.69	74.00	-27.31	41.69	3	Horizontal	184	2.44	-	32.53	5.72	33.25
AV	4.88588G	36.08	54.00	-17.92	31.06	3	Horizontal	184	2.44	-	32.54	5.73	33.25
PK	7.31652G	52.31	74.00	-21.69	42.09	3	Horizontal	341	1.29	-	37.20	7.12	34.10
AV	7.31196G	42.22	54.00	-11.78	31.99	3	Horizontal	341	1.29	-	37.20	7.12	34.09

2.4-2.4835GHz\_BT-LE(2Mbps)

2478MHz\_TX

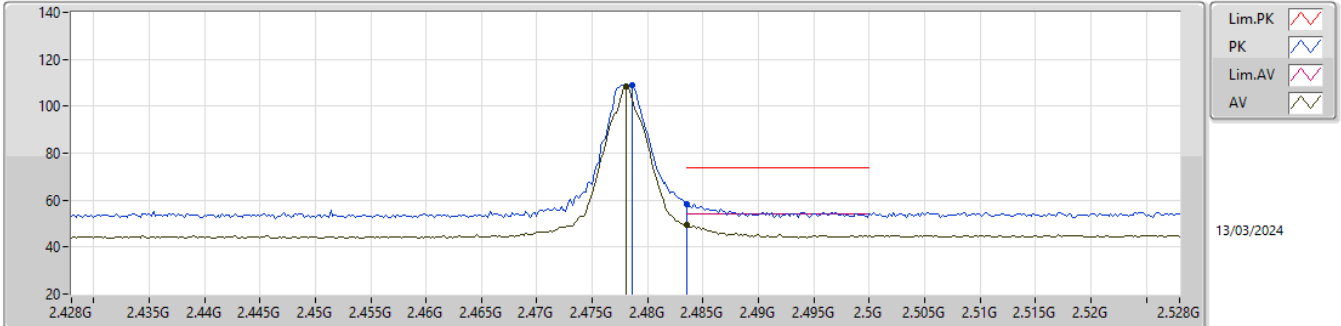

EUT\_X\_1TX  
Setting 160  
04-E-R-7

Type	Freq (Hz)	Level (dBuV/m)	Limit (dBuV/m)	Margin (dB)	Raw (dBuV)	Dist (m)	Condition	Azimuth (°)	Height (m)	Comment	AF (dB)	CL (dB)	PA (dB)
PK	2.4786G	109.19	Inf	-Inf	78.20	3	Vertical	348	1.95	-	27.60	3.39	-
AV	2.478G	108.41	Inf	-Inf	77.42	3	Vertical	348	1.95	-	27.60	3.39	-
PK	2.4835G	58.39	74.00	-15.61	27.35	3	Vertical	348	1.95	-	27.64	3.40	-
AV	2.4835G	49.30	54.00	-4.70	18.26	3	Vertical	348	1.95	-	27.64	3.40	-

2.4-2.4835GHz\_BT-LE(2Mbps)

2478MHz\_TX

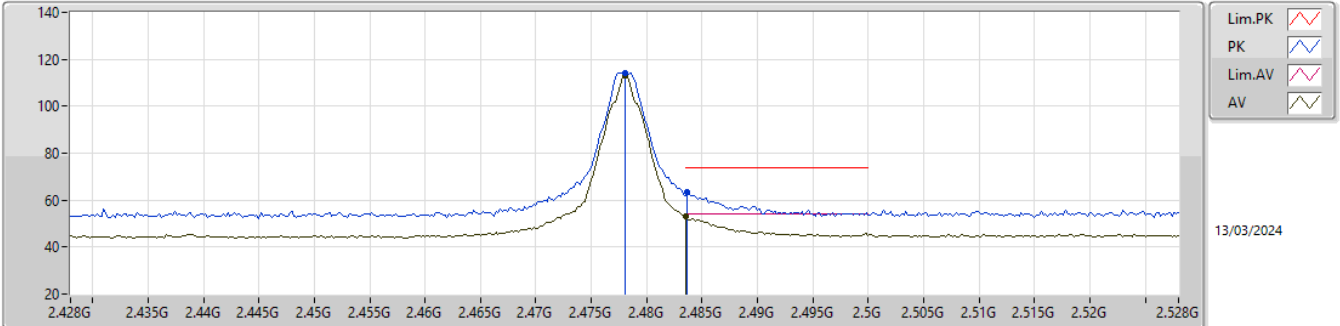

EUT\_X\_1TX  
Setting 160  
04-E-R-7

Type	Freq (Hz)	Level (dBuV/m)	Limit (dBuV/m)	Margin (dB)	Raw (dBuV)	Dist (m)	Condition	Azimuth (°)	Height (m)	Comment	AF (dB)	CL (dB)	PA (dB)
PK	2.478G	114.12	Inf	-Inf	83.13	3	Horizontal	35	2.43	-	27.60	3.39	-
AV	2.478G	113.35	Inf	-Inf	82.36	3	Horizontal	35	2.43	-	27.60	3.39	-
PK	2.4836G	63.36	74.00	-10.64	32.32	3	Horizontal	35	2.43	-	27.64	3.40	-
AV	2.4835G	53.17	54.00	-0.83	22.13	3	Horizontal	35	2.43	-	27.64	3.40	-

2.4-2.4835GHz\_BT-LE(2Mbps)

2480MHz\_TX

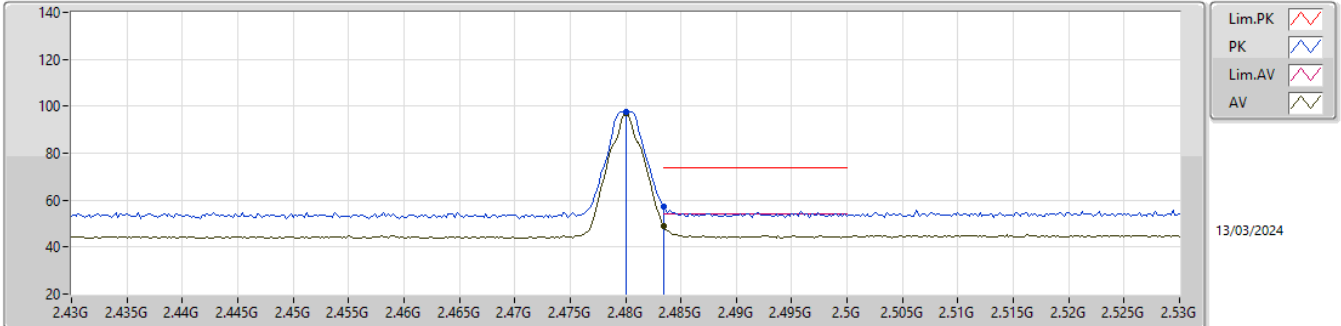

EUT\_X\_1TX  
Setting 50  
04-E-R-7

Type	Freq (Hz)	Level (dBuV/m)	Limit (dBuV/m)	Margin (dB)	Raw (dBuV)	Dist (m)	Condition	Azimuth (°)	Height (m)	Comment	AF (dB)	CL (dB)	PA (dB)
PK	2.48G	97.65	Inf	-Inf	66.66	3	Vertical	345	1.68	-	27.60	3.39	-
AV	2.48G	96.93	Inf	-Inf	65.94	3	Vertical	345	1.68	-	27.60	3.39	-
PK	2.4835G	57.50	74.00	-16.50	26.46	3	Vertical	345	1.68	-	27.64	3.40	-
AV	2.4835G	49.18	54.00	-4.82	18.14	3	Vertical	345	1.68	-	27.64	3.40	-

2.4-2.4835GHz\_BT-LE(2Mbps)

2480MHz\_TX

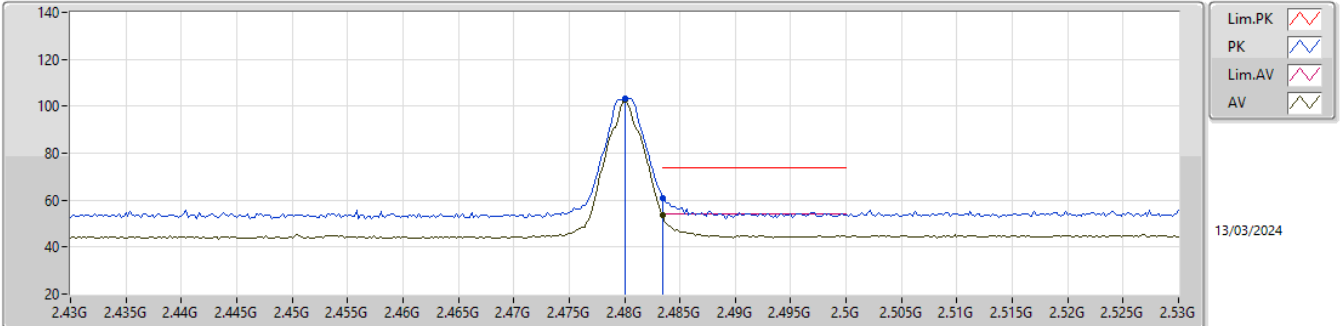

EUT\_X\_1TX  
Setting 50  
04-E-R-7

Type	Freq (Hz)	Level (dBuV/m)	Limit (dBuV/m)	Margin (dB)	Raw (dBuV)	Dist (m)	Condition	Azimuth (°)	Height (m)	Comment	AF (dB)	CL (dB)	PA (dB)
PK	2.48G	103.22	Inf	-Inf	72.23	3	Horizontal	49	2.68	-	27.60	3.39	-
AV	2.48G	102.51	Inf	-Inf	71.52	3	Horizontal	49	2.68	-	27.60	3.39	-
PK	2.4835G	60.86	74.00	-13.14	29.82	3	Horizontal	49	2.68	-	27.64	3.40	-
AV	2.4835G	53.65	54.00	-0.35	22.61	3	Horizontal	49	2.68	-	27.64	3.40	-

2.4-2.4835GHz\_BT-LE(2Mbps)

2480MHz\_TX

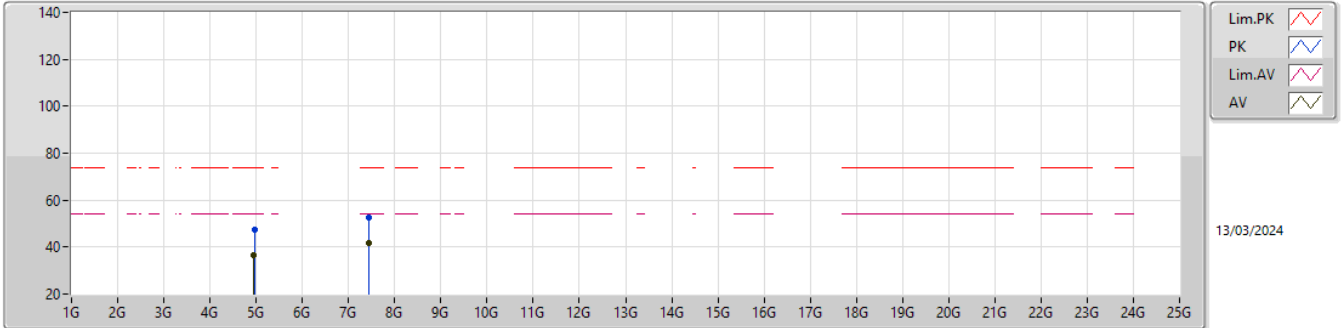

EUT\_X\_1TX  
Setting 50  
04-E-R-7

Type	Freq (Hz)	Level (dBuV/m)	Limit (dBuV/m)	Margin (dB)	Raw (dBuV)	Dist (m)	Condition	Azimuth (°)	Height (m)	Comment	AF (dB)	CL (dB)	PA (dB)
PK	4.96552G	47.20	74.00	-26.80	41.92	3	Vertical	318	1.58	-	32.70	5.80	33.22
AV	4.9489G	36.63	54.00	-17.37	31.38	3	Vertical	318	1.58	-	32.70	5.78	33.23
PK	7.44888G	52.47	74.00	-21.53	42.20	3	Vertical	70	1.50	-	37.20	7.22	34.15
AV	7.45176G	41.68	54.00	-12.32	31.41	3	Vertical	70	1.50	-	37.20	7.22	34.15



2.4-2.4835GHz\_BT-LE(2Mbps)

2480MHz\_TX

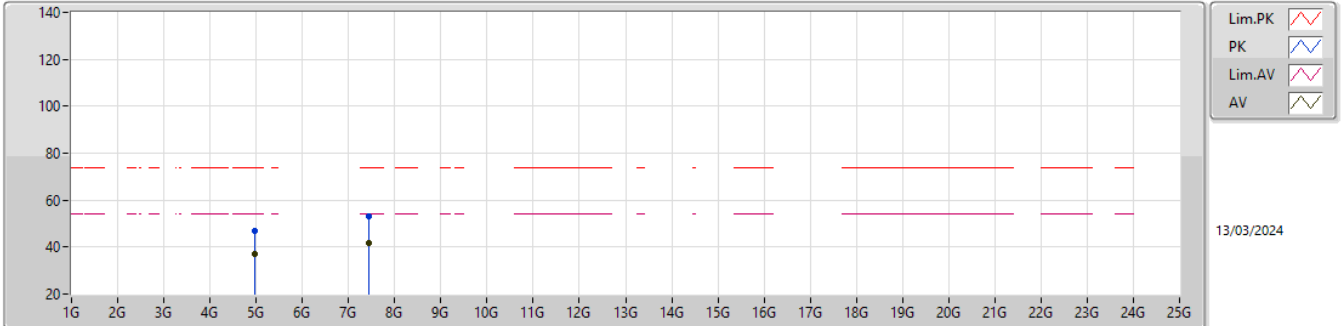

EUT\_X\_1TX  
Setting 50  
04-E-R-7

Type	Freq (Hz)	Level (dBuV/m)	Limit (dBuV/m)	Margin (dB)	Raw (dBuV)	Dist (m)	Condition	Azimuth (°)	Height (m)	Comment	AF (dB)	CL (dB)	PA (dB)
PK	4.97458G	47.15	74.00	-26.85	41.86	3	Horizontal	156	1.98	-	32.70	5.81	33.22
AV	4.95916G	36.89	54.00	-17.11	31.62	3	Horizontal	156	1.98	-	32.70	5.79	33.22
PK	7.44942G	52.90	74.00	-21.10	42.63	3	Horizontal	91	1.12	-	37.20	7.22	34.15
AV	7.44756G	41.84	54.00	-12.16	31.57	3	Horizontal	91	1.12	-	37.20	7.22	34.15