



Mike Wazowski

Antenna Test Report

(DVT1 Pre-build unit)

Date : Jun. 22, 2021
Prepared by : AK Chen



Outline

- Antenna Structure & Placement
- Test Case Definition
- Case 1 Antenna Performance
- Case 2 Antenna Performance
- Case 3 Antenna Performance
- Case 4 Antenna Performance
- Case 5 Antenna Performance
- Peak Gain & Efficiency Comparison
- Pattern Comparison

- Brand: SERCOMM
- Model Name: HC910

Antenna Structure & Placement

Ant No.	Operating Band	Type	Material	Feeding	Dimension
Ant 1	WiFi Dual Band / BT	PIFA	FPC	Cable	30(L) x 31(W) x 0.15(T) mm ³
Ant 2	WiFi Dual Band / BT	PIFA	FPC	Cable	30(L) x 31(W) x 0.15(T) mm ³

Case 1

	Tilt angle of lens	Rotation angle of lens holder
Case 1	0 degree	0 degree
Case 2	Middle angle	0 degree
Case 3	Middle angle	180 degree
Case 4	Max angle	0 degree
Case 5	Max angle	180 degree

Case 1 : Return Loss – Ant 1

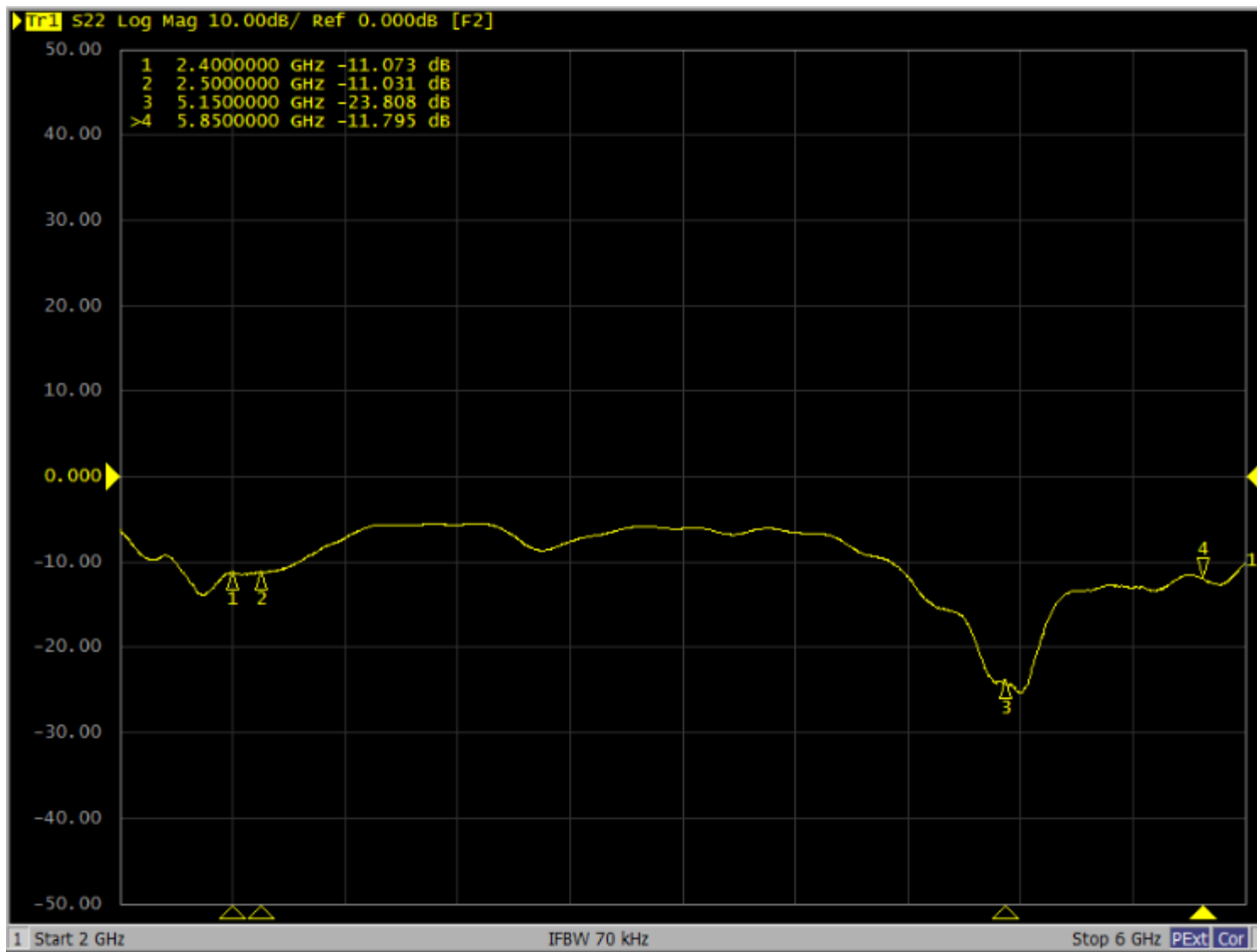

Case 1 : Return Loss – Ant 2

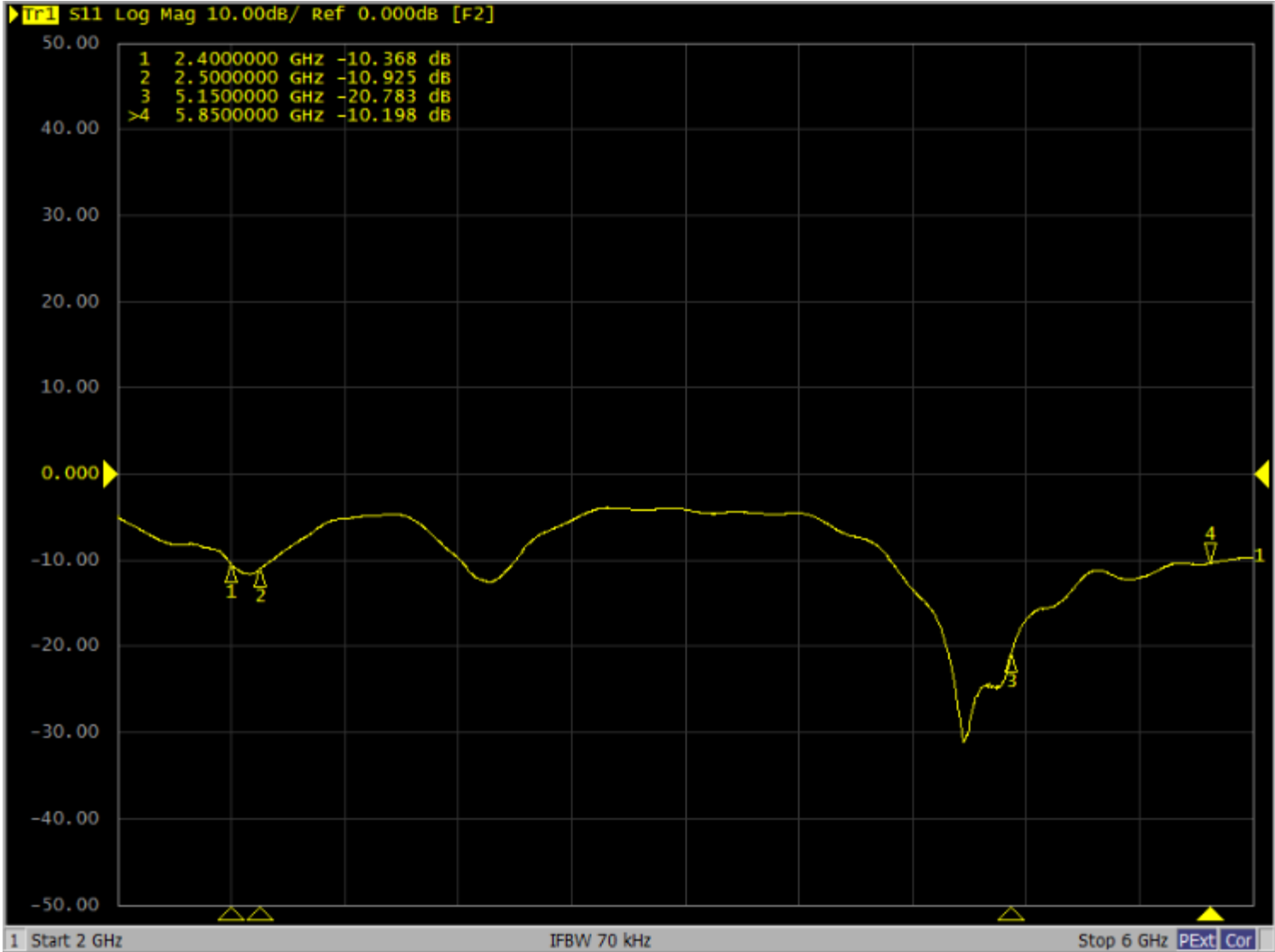

Case 1 : Isolation – Ant 1 & Ant 2

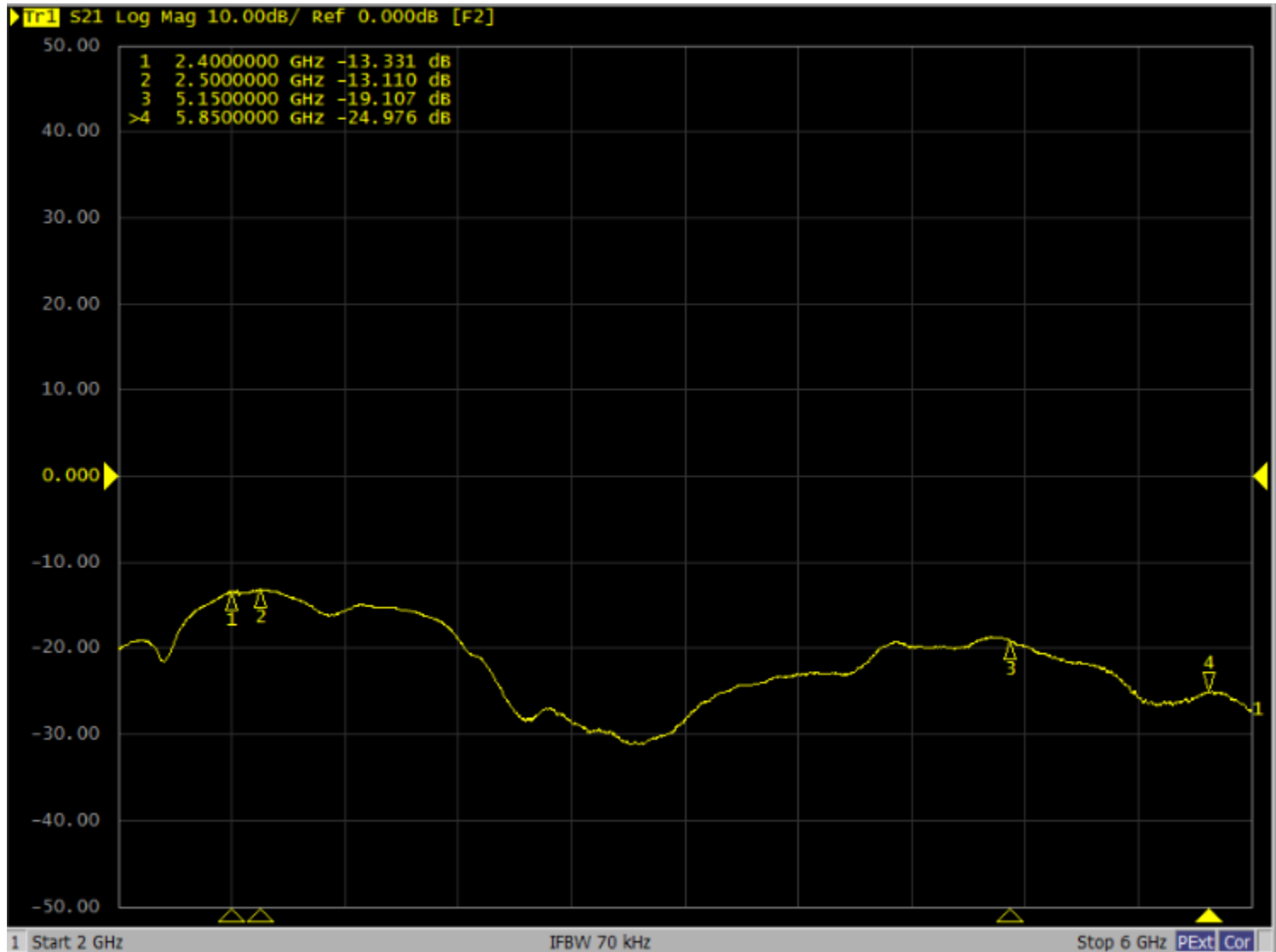

Case 1 : Radiation Pattern – Ant 1 @WiFi 2.4G/BT

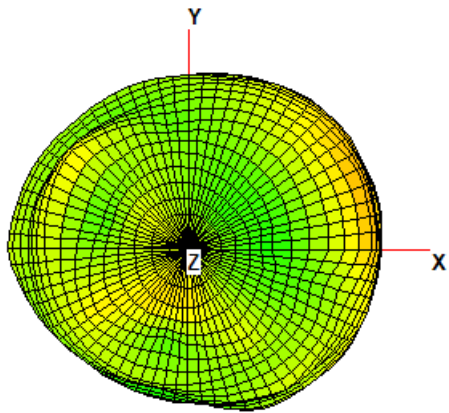
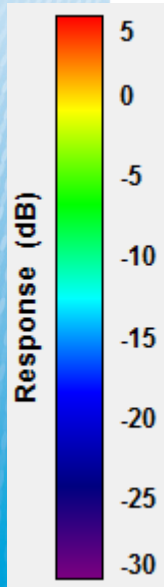

XY-Plane

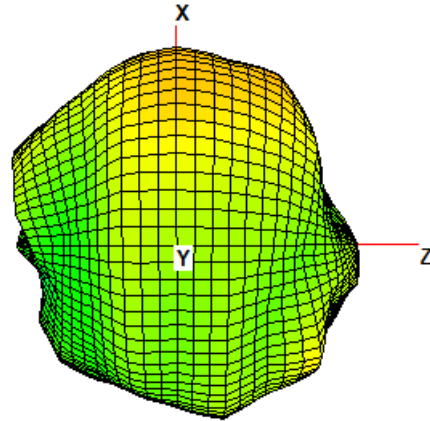

XZ-Plane

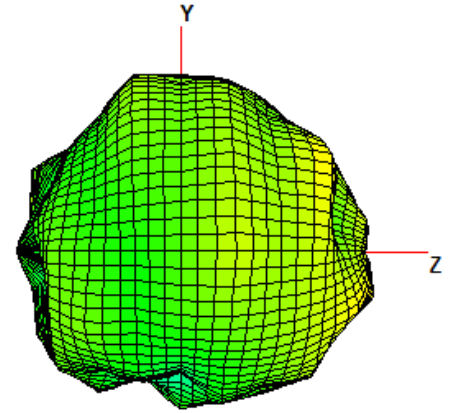

YZ-Plane

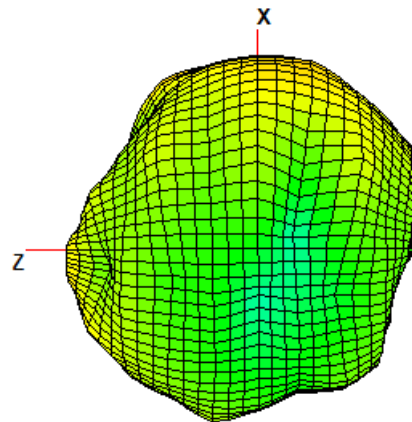

XZ-Plane

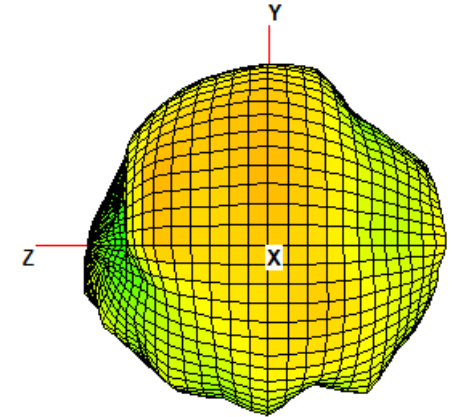

YZ-Plane

Case 1 : Radiation Pattern – Ant 1 @WiFi 5G

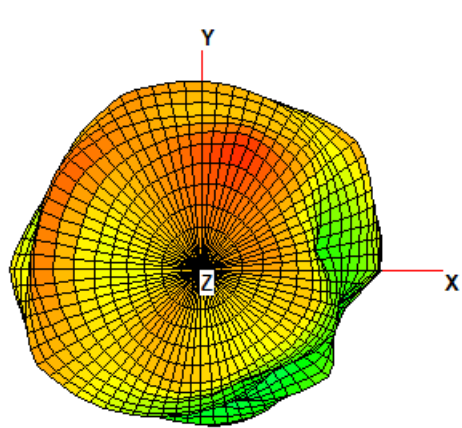
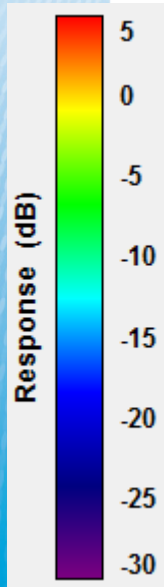

XY-Plane

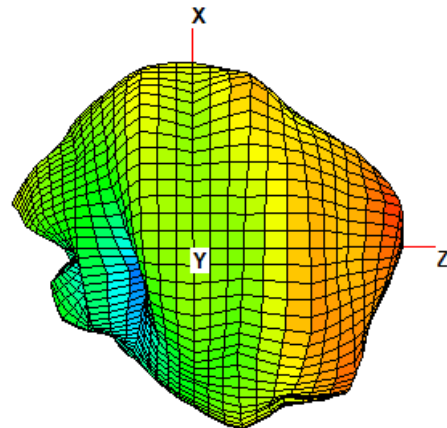

XZ-Plane

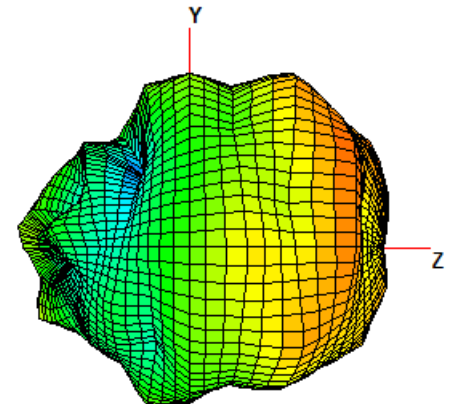

YZ-Plane

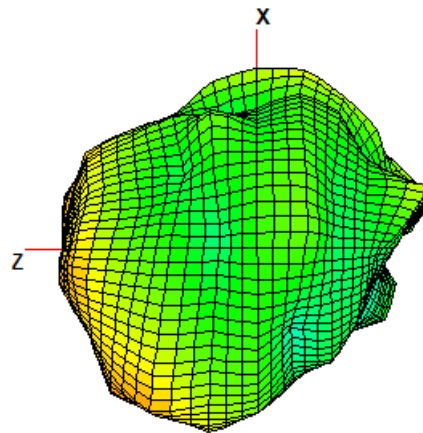

XZ-Plane

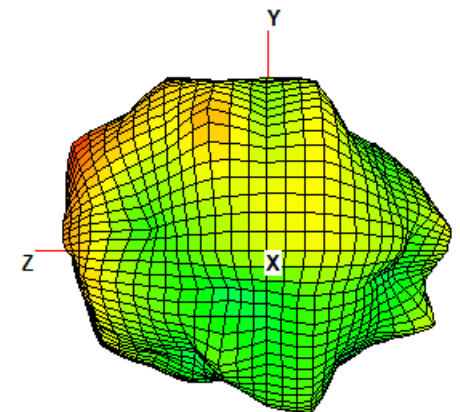

YZ-Plane

Case 1 : Radiation Pattern – Ant 2 @WiFi 2.4G/BT

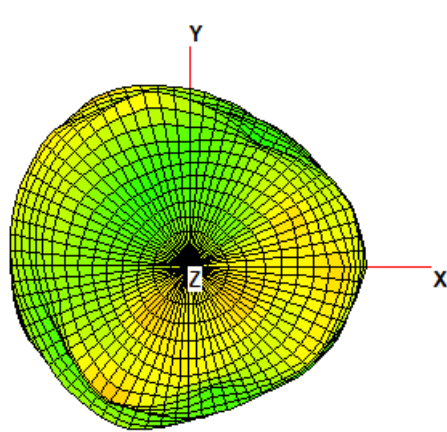
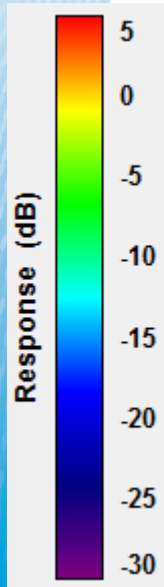

XY-Plane

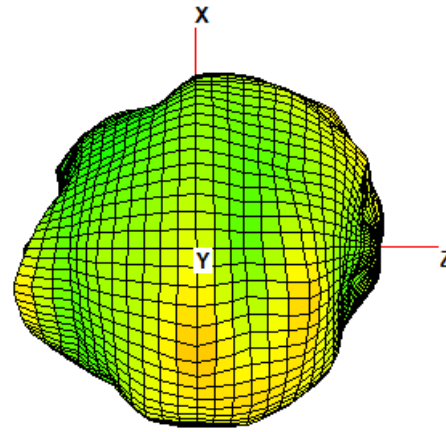

XZ-Plane

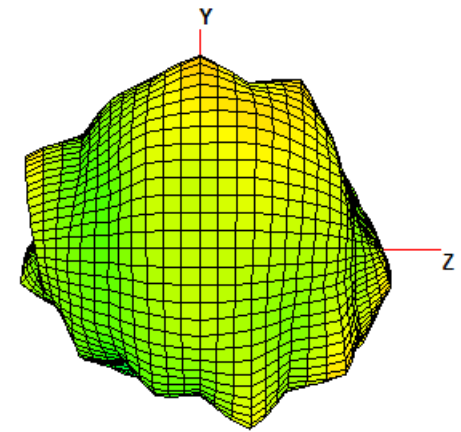

YZ-Plane

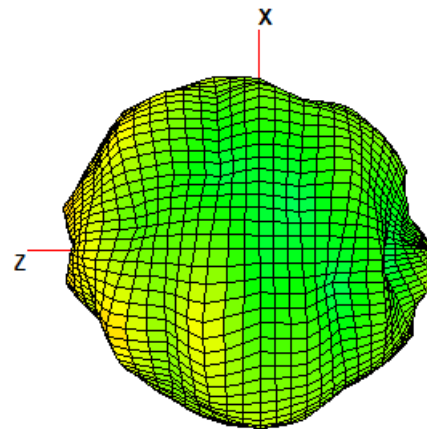

XZ-Plane

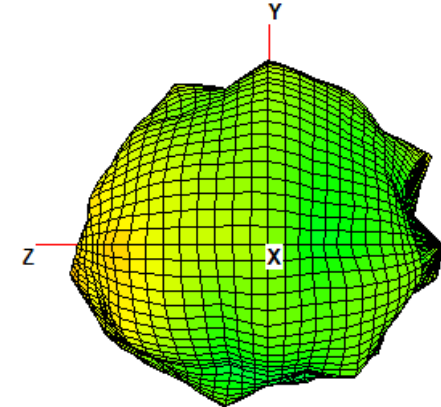

YZ-Plane

Case 1 : Radiation Pattern – Ant 2 @WiFi 5G

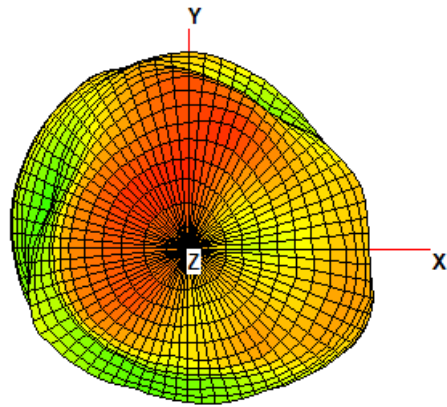
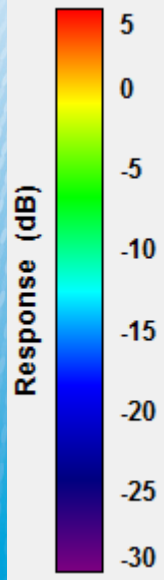

XY-Plane

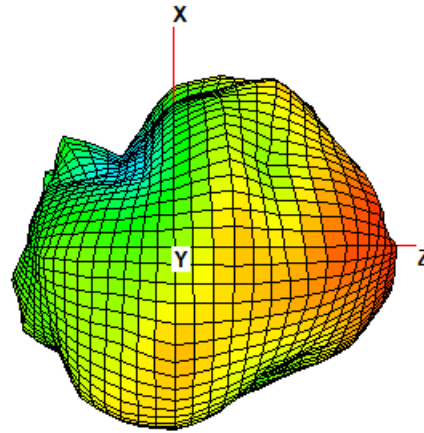

XZ-Plane

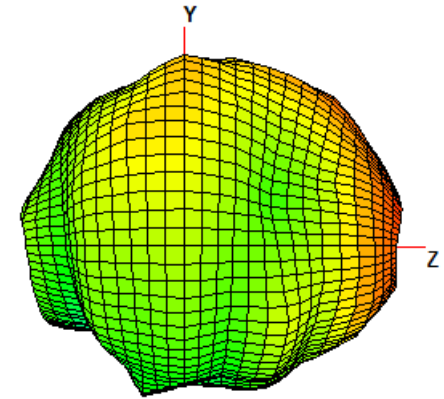

YZ-Plane

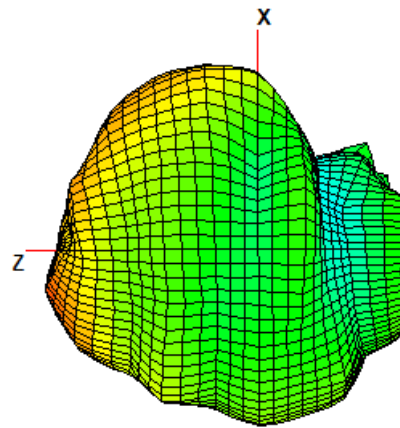

XZ-Plane

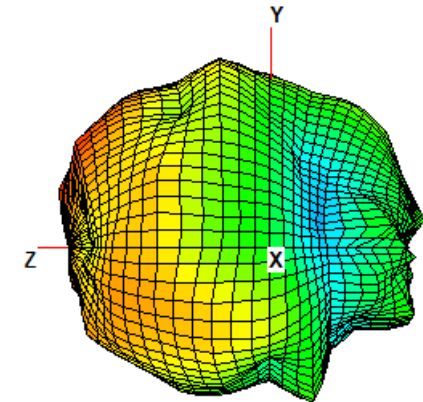

YZ-Plane

Case 2

	Tilt angle of lens	Rotation angle of lens holder
Case 1	0 degree	0 degree
Case 2	Middle angle	0 degree
Case 3	Middle angle	180 degree
Case 4	Max angle	0 degree
Case 5	Max angle	180 degree

Case 2 : Return Loss – Ant 1

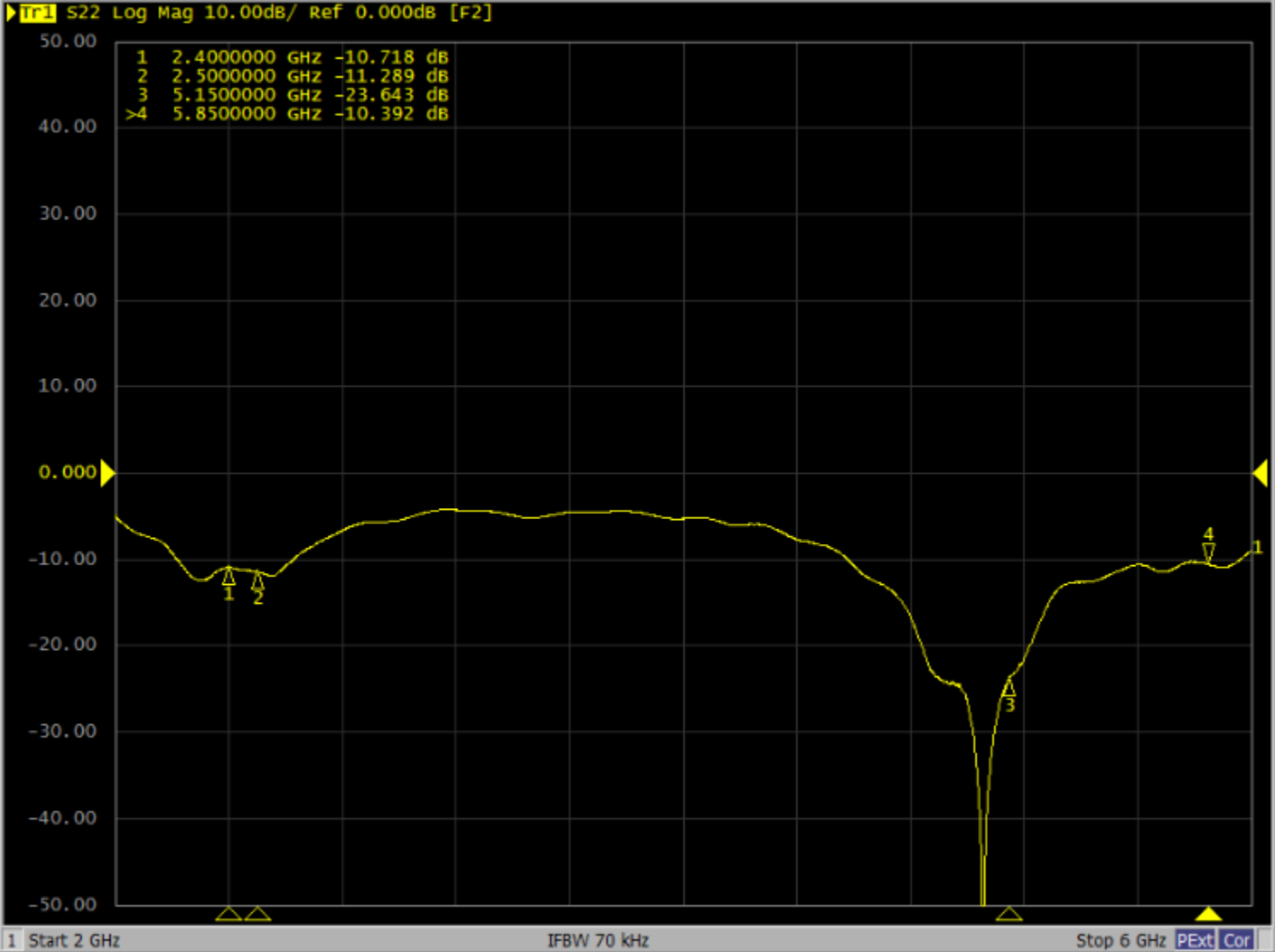

Case 2 : Return Loss – Ant 2

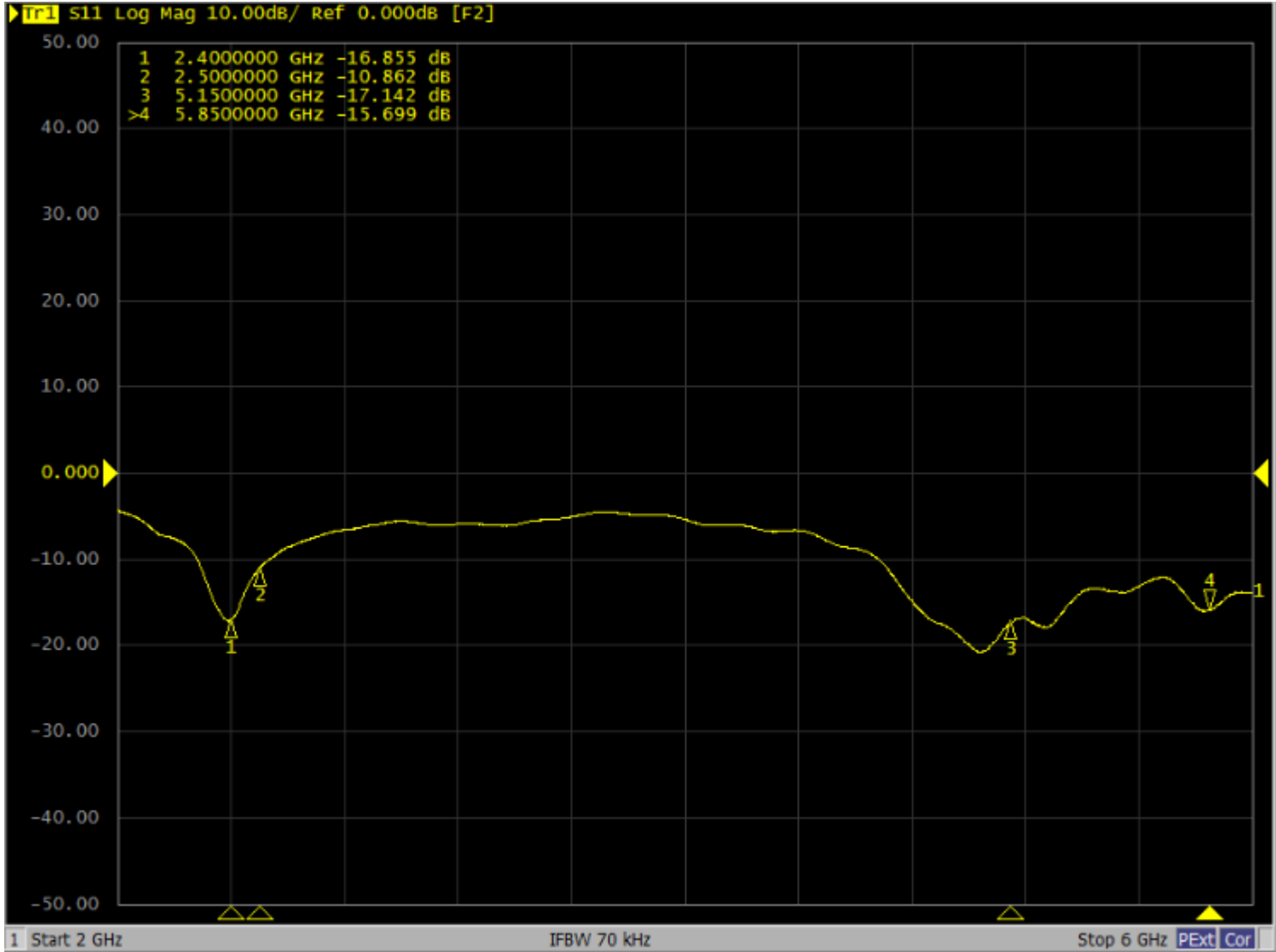

Case 2 : Isolation – Ant 1 & Ant 2

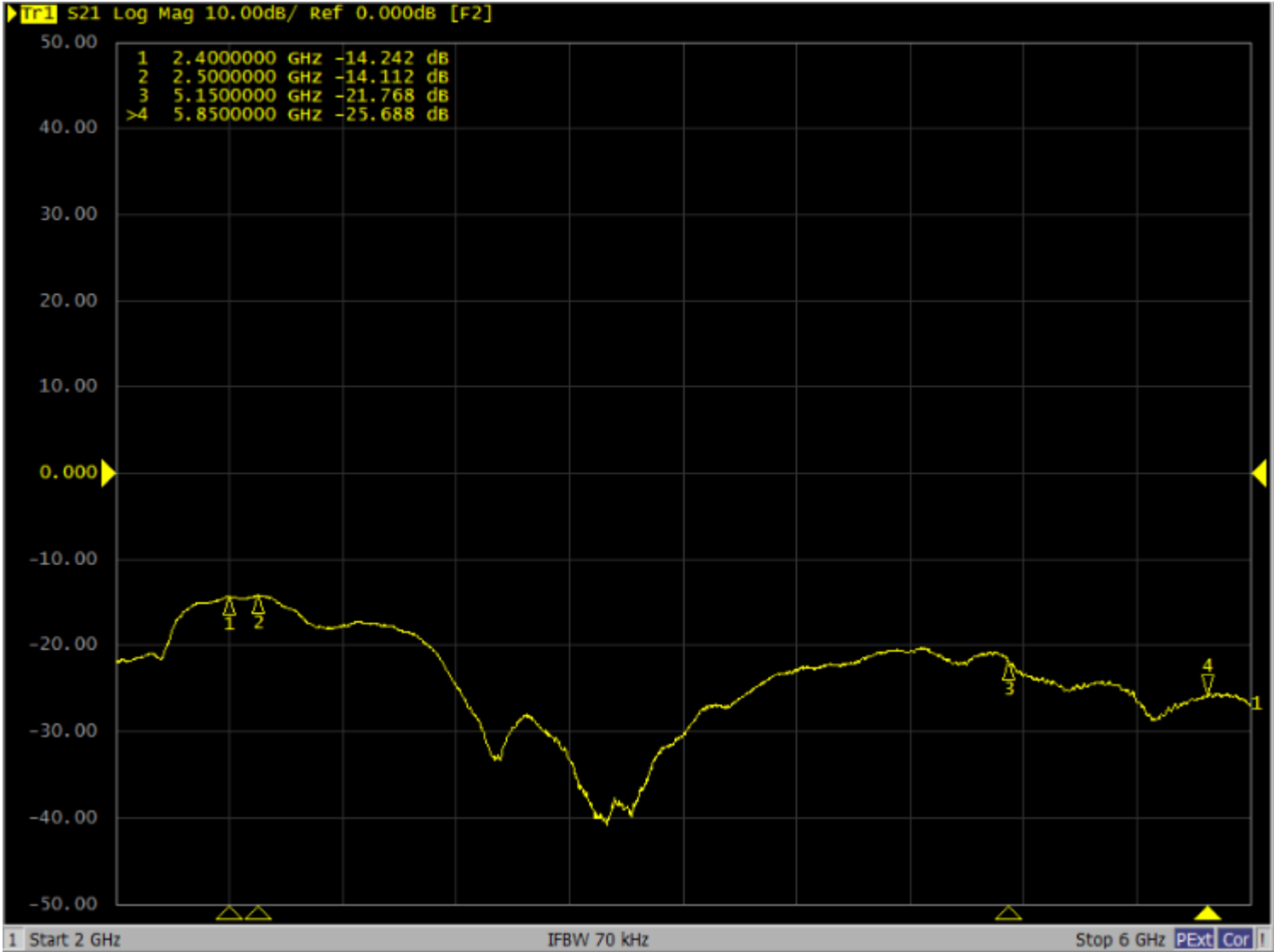

Case 2 : Radiation Pattern – Ant 1 @WiFi 2.4G/BT

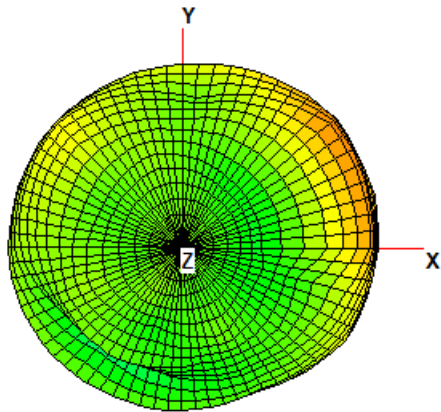
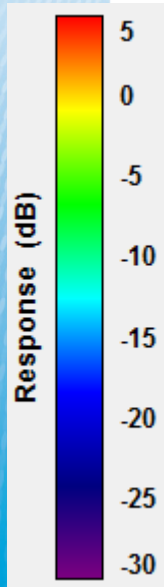

XY-Plane

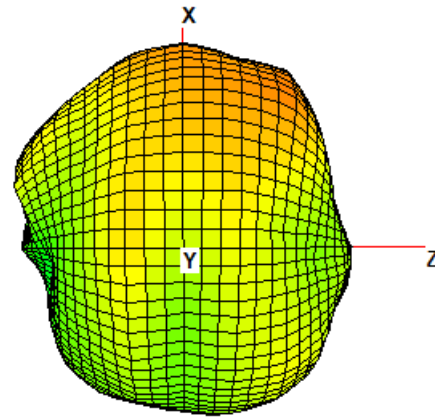

XZ-Plane

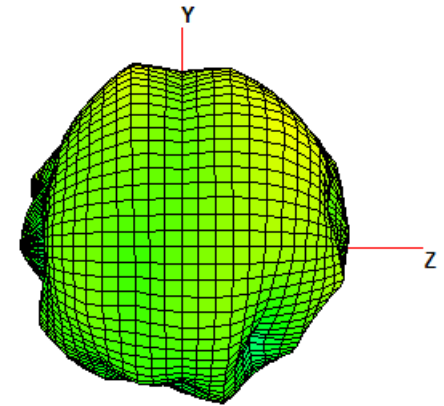

YZ-Plane

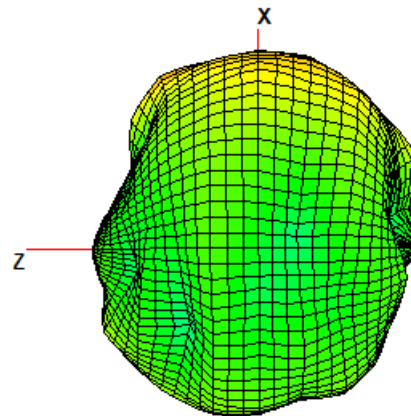

XZ-Plane

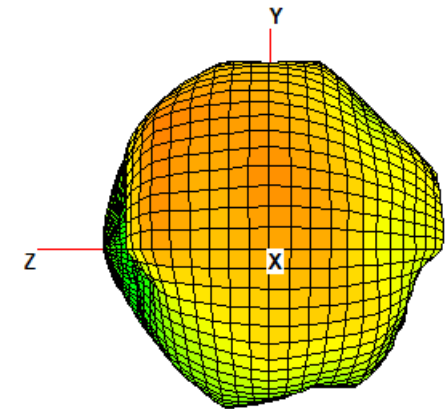

YZ-Plane

Case 2 : Radiation Pattern – Ant 1 @WiFi 5G

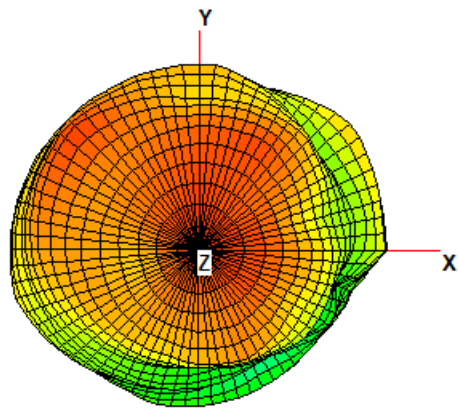
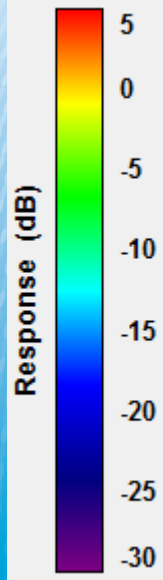

XY-Plane

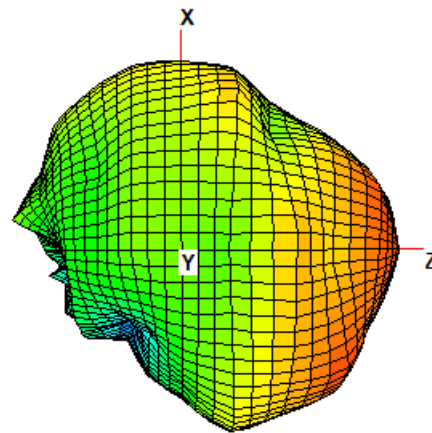

XZ-Plane

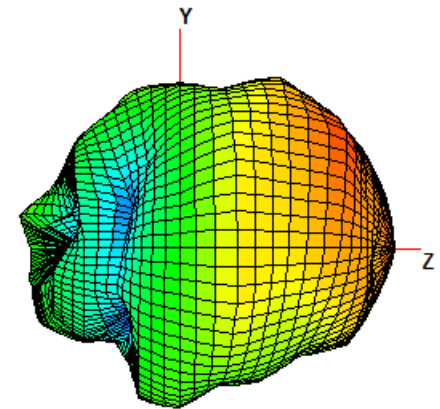

YZ-Plane

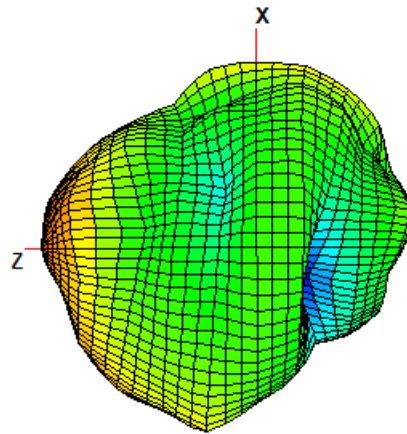

XZ-Plane

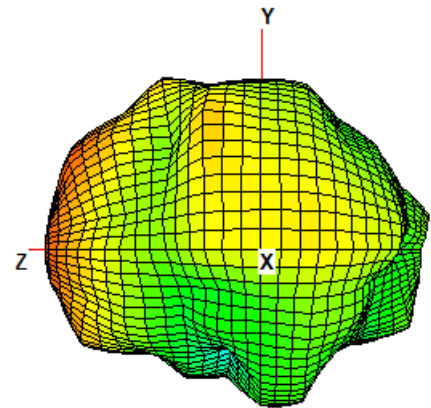

YZ-Plane

Case 2 : Radiation Pattern – Ant 2 @WiFi 2.4G/BT

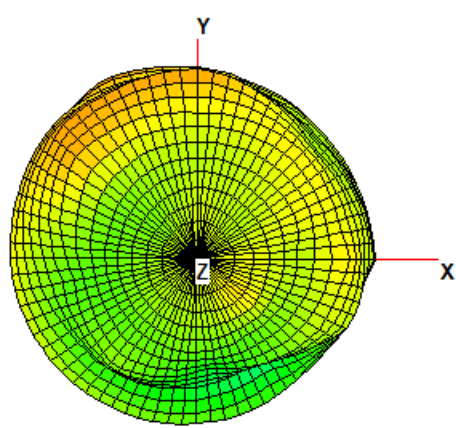
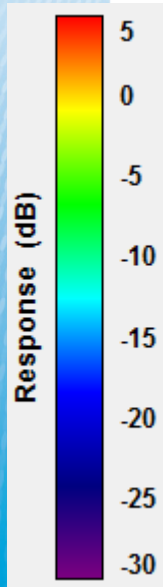

XY-Plane

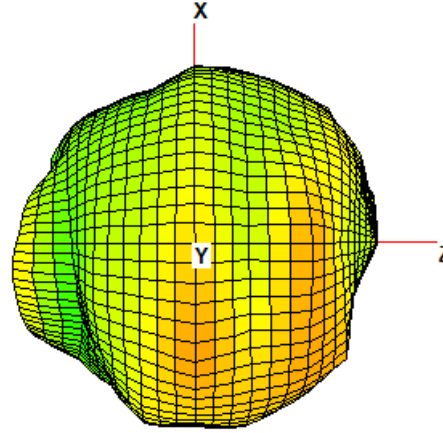

XZ-Plane

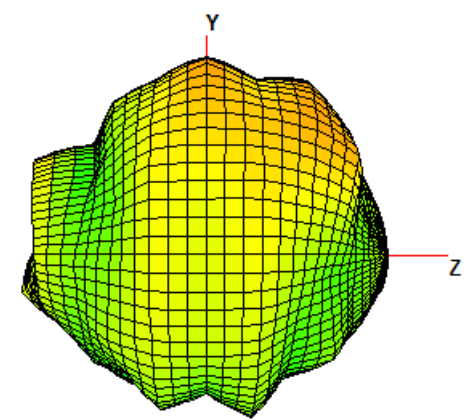

YZ-Plane

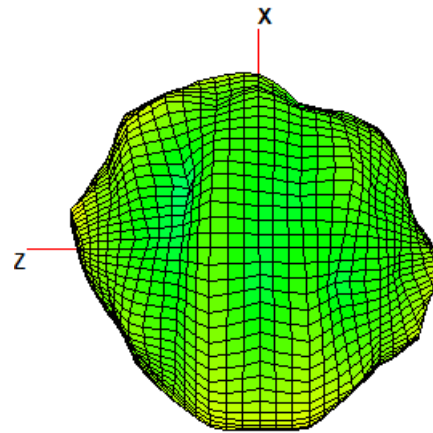

XZ-Plane

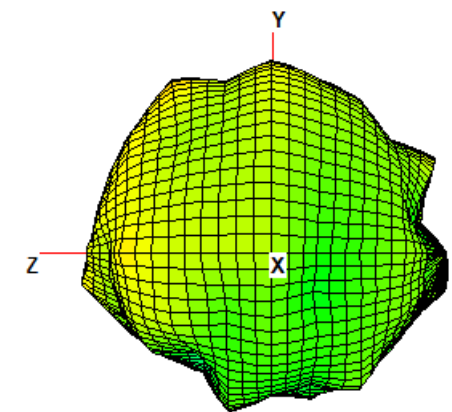

YZ-Plane

Case 2 : Radiation Pattern – Ant 2 @WiFi 5G

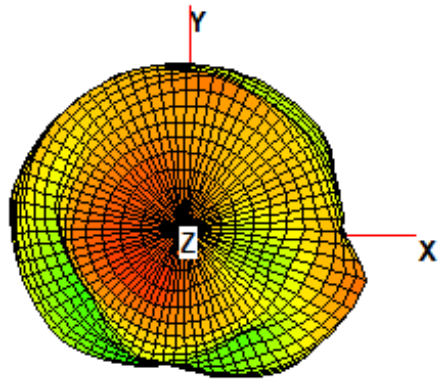
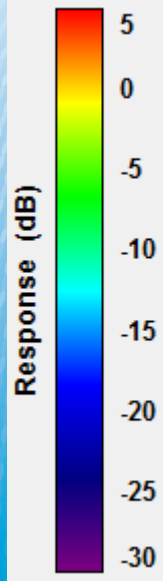

XY-Plane

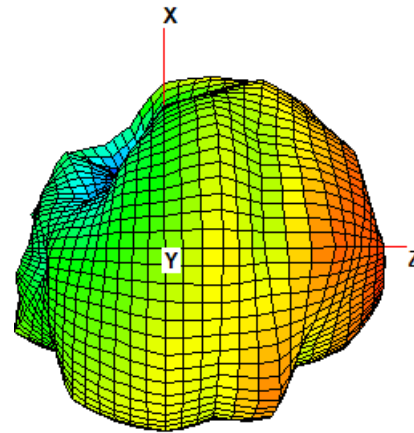

XZ-Plane

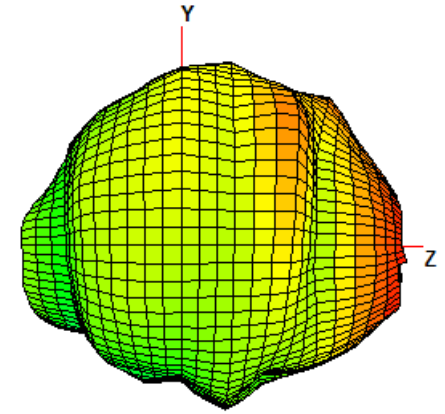

YZ-Plane

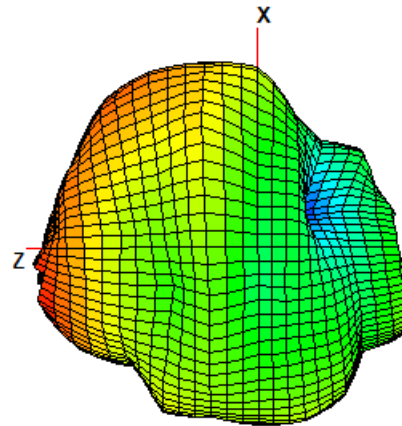

XZ-Plane

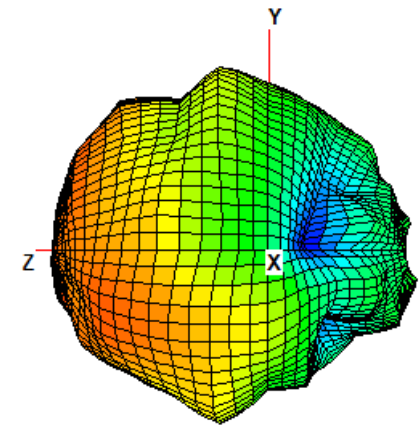

YZ-Plane

Case 3

	Tilt angle of lens	Rotation angle of lens holder
Case 1	0 degree	0 degree
Case 2	Middle angle	0 degree
Case 3	Middle angle	180 degree
Case 4	Max angle	0 degree
Case 5	Max angle	180 degree

Case 3 : Return Loss – Ant 1

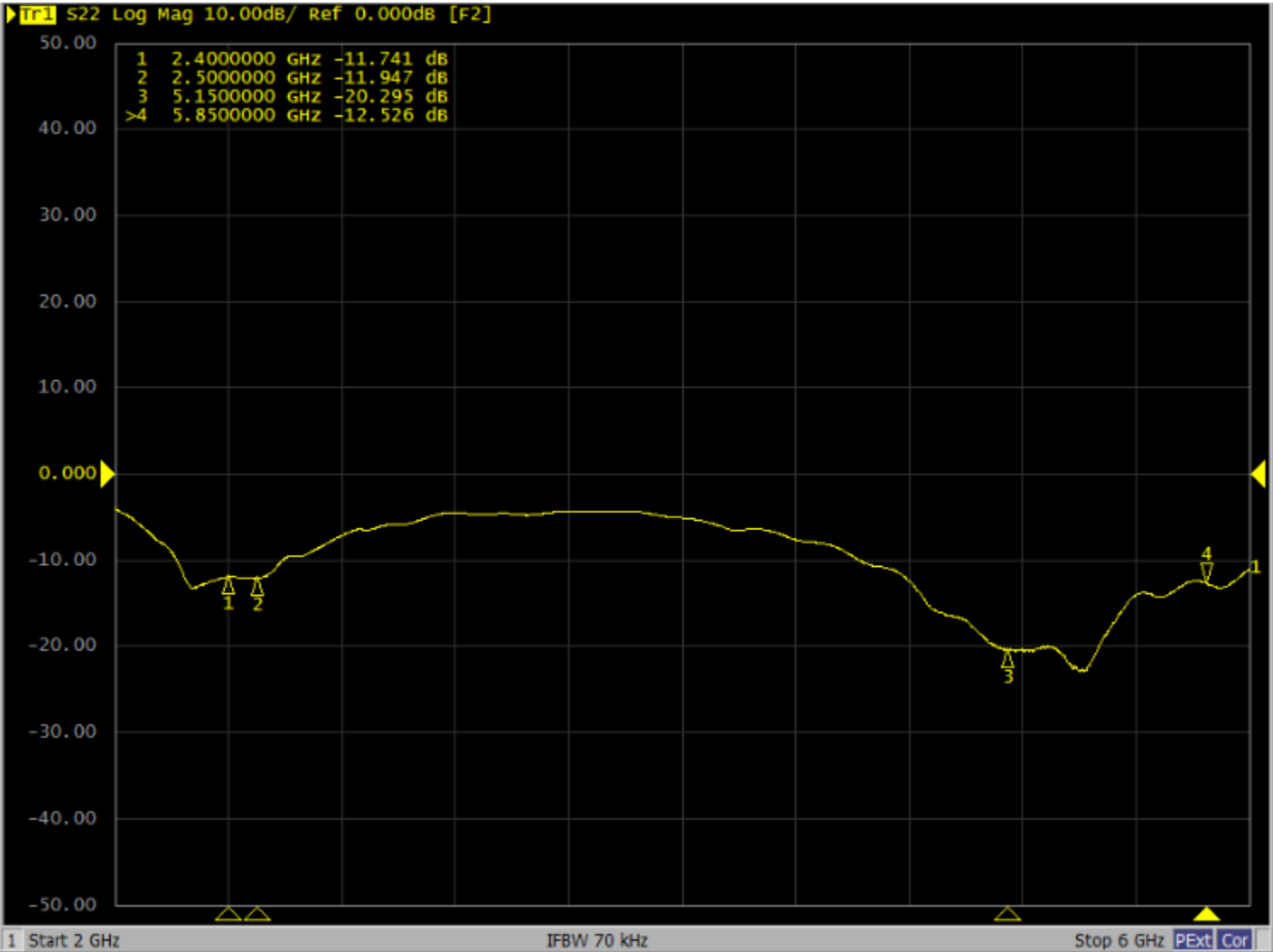

Case 3 : Return Loss – Ant 2

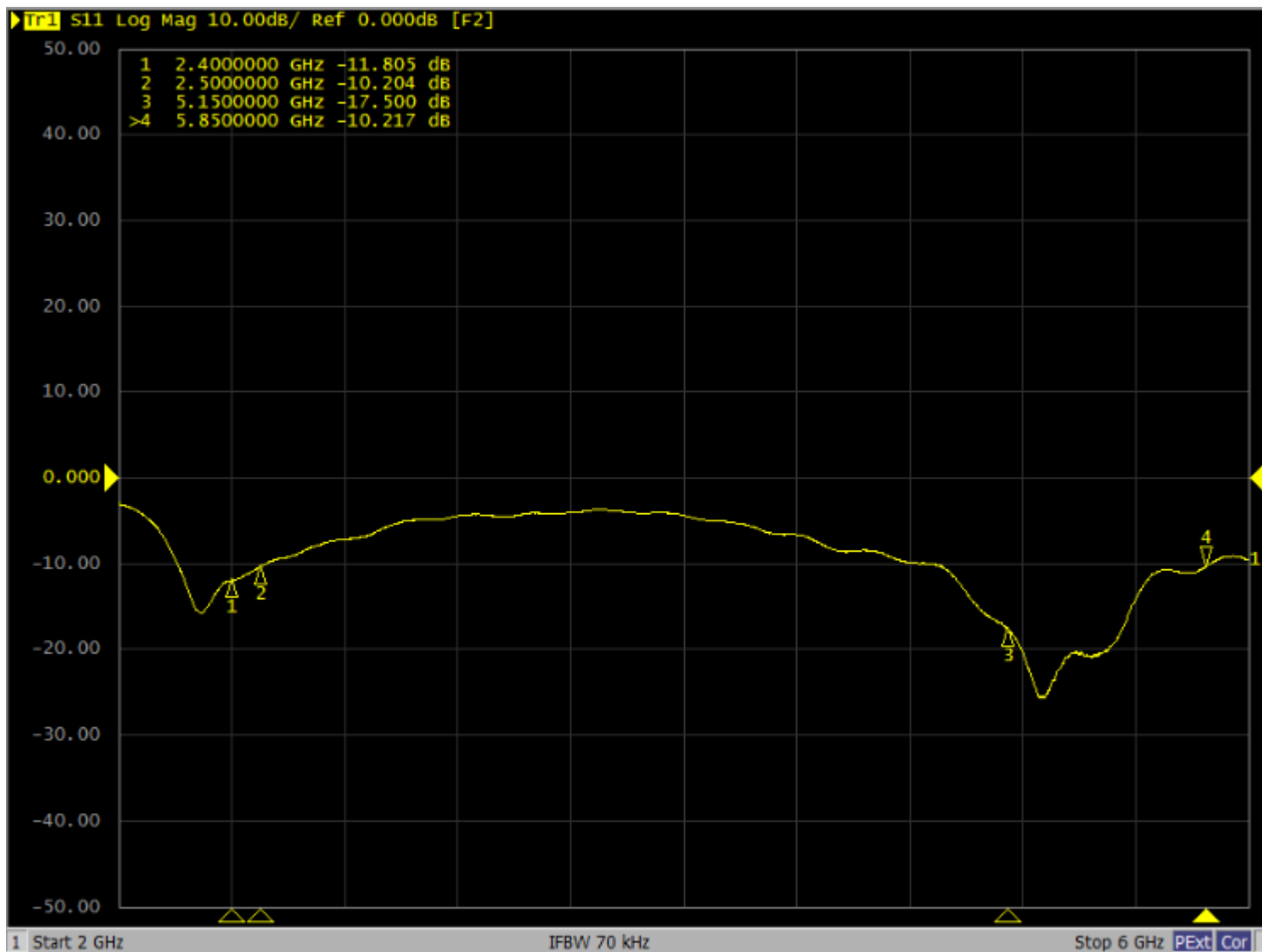

Case 3 : Isolation – Ant 1 & Ant 2

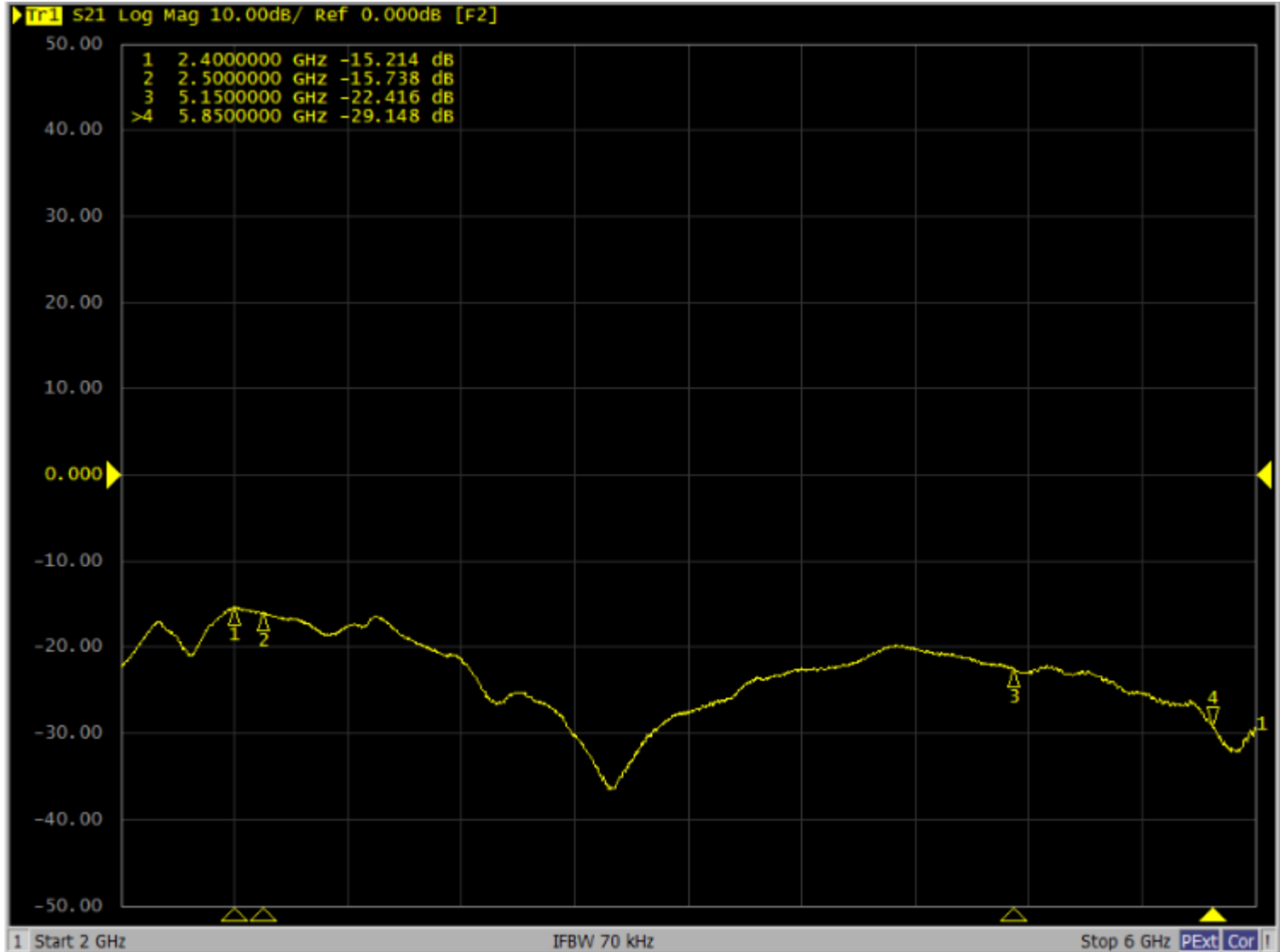

Case 3 : Radiation Pattern – Ant 1 @WiFi 2.4G/BT

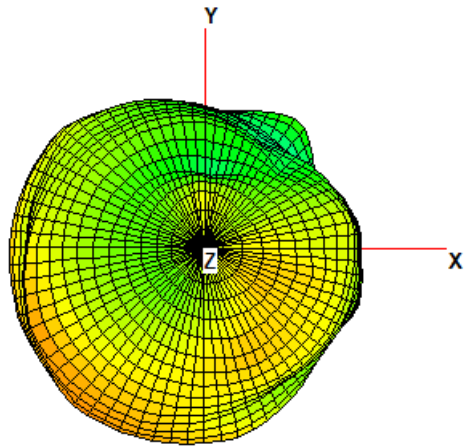
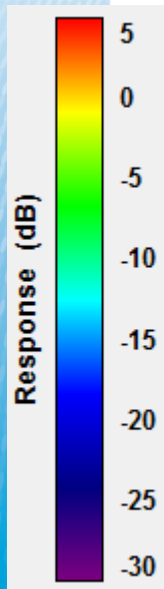

XY-Plane

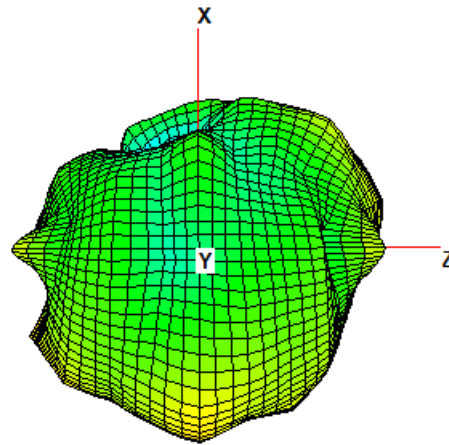

XZ-Plane

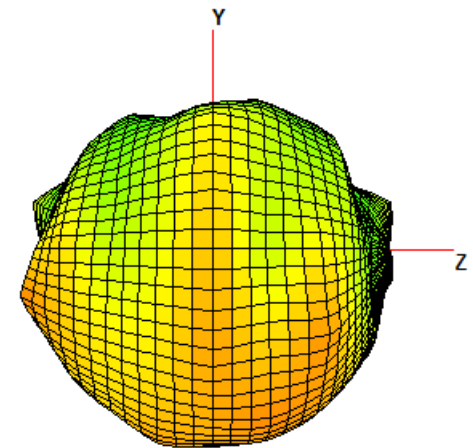

YZ-Plane

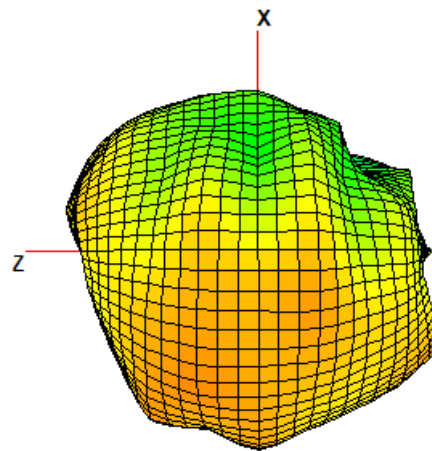

XZ-Plane

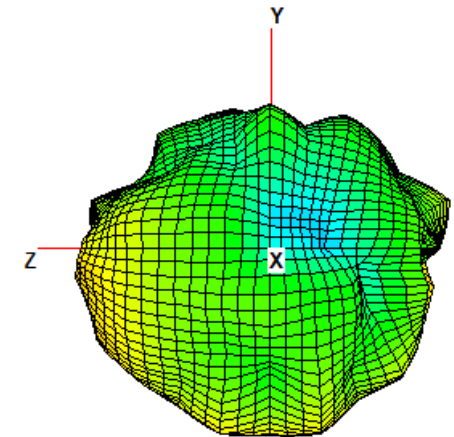

YZ-Plane

Case 3 : Radiation Pattern – Ant 1 @WiFi 5G

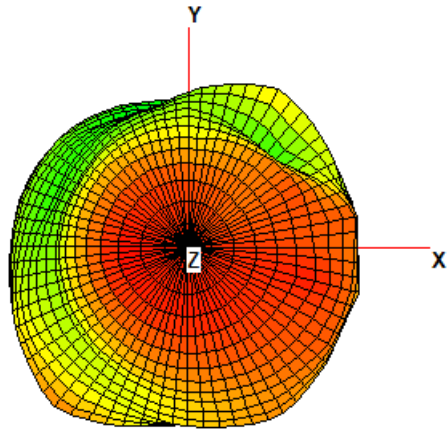
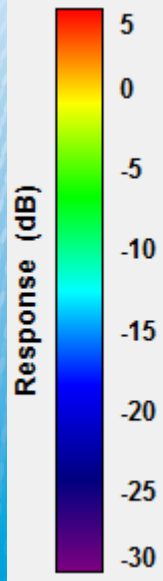

XY-Plane

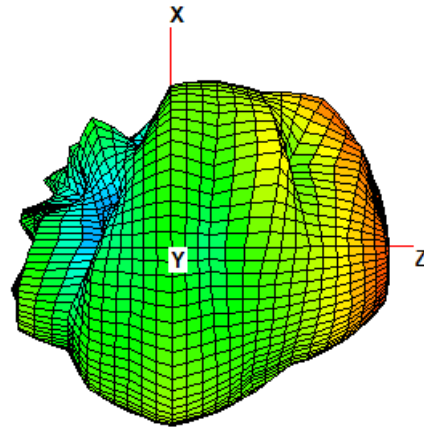

XZ-Plane

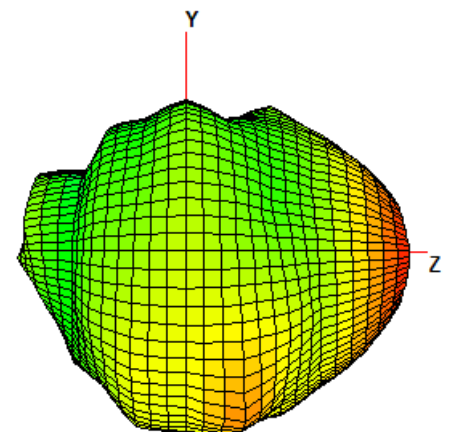

YZ-Plane

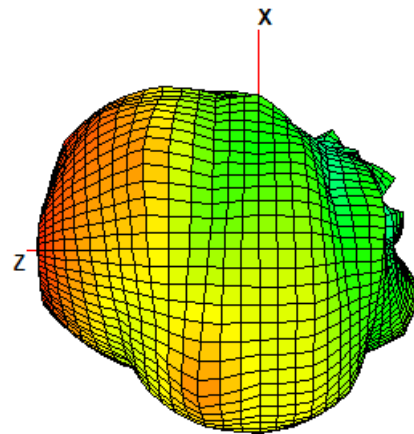

XZ-Plane

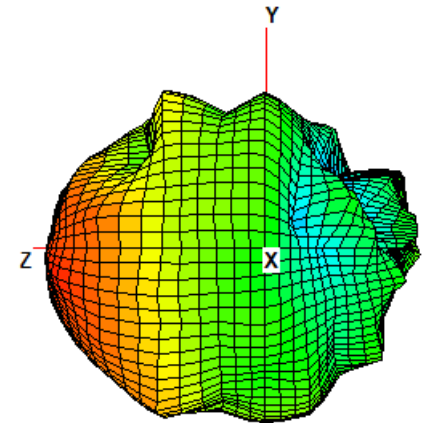

YZ-Plane

Case 3 : Radiation Pattern – Ant 2 @WiFi 2.4G/BT

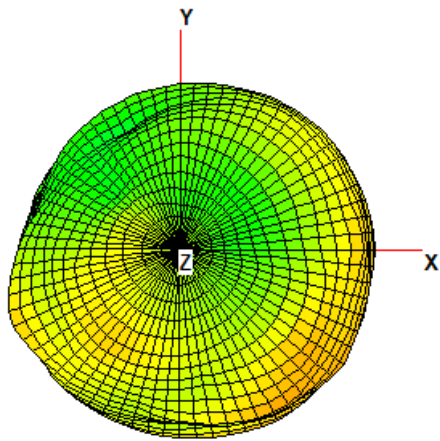
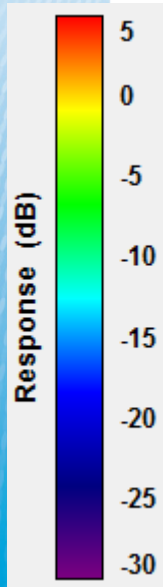

XY-Plane

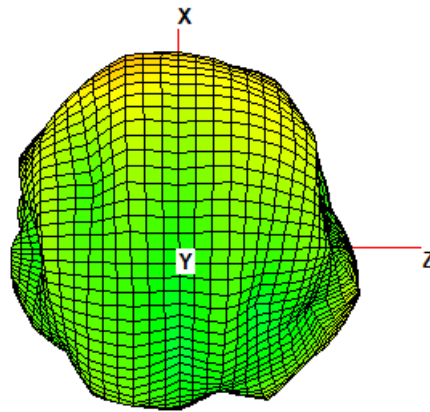

XZ-Plane

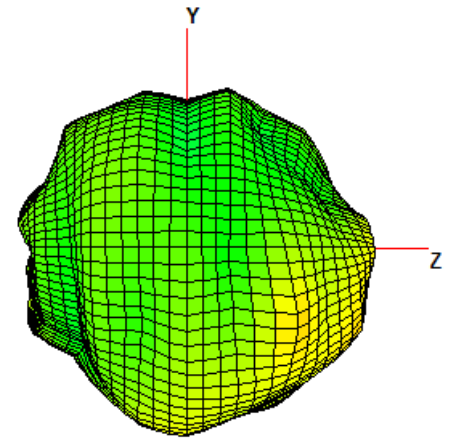

YZ-Plane

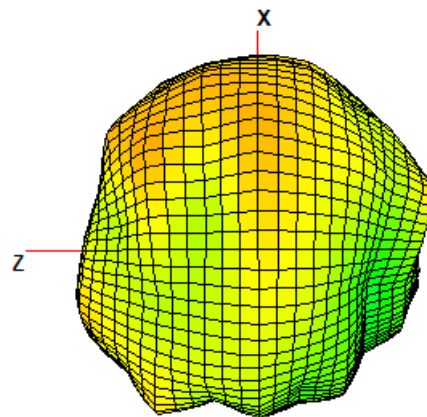

XZ-Plane

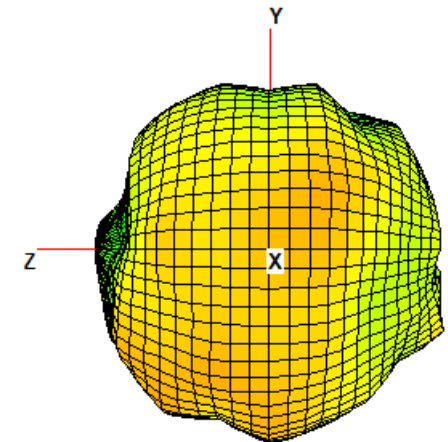

YZ-Plane

Case 3 : Radiation Pattern – Ant 2 @WiFi 5G

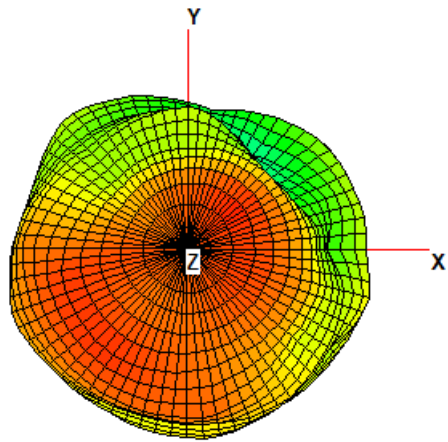
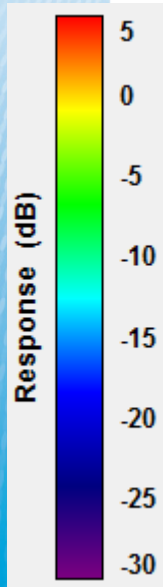

XY-Plane

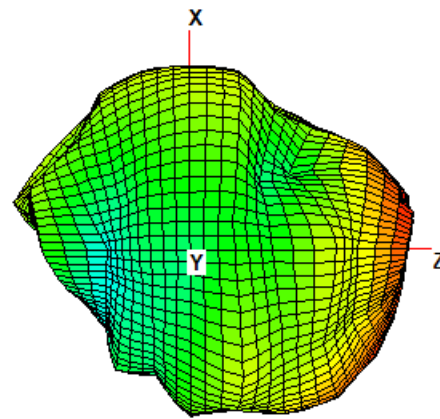

XZ-Plane

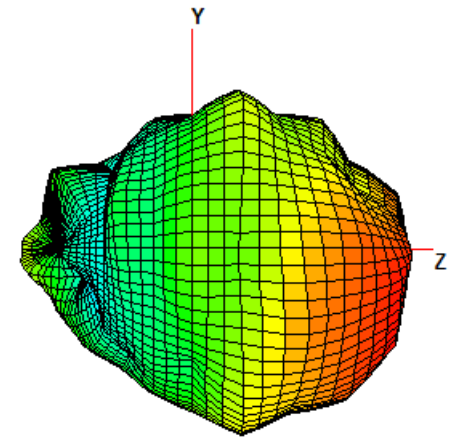

YZ-Plane

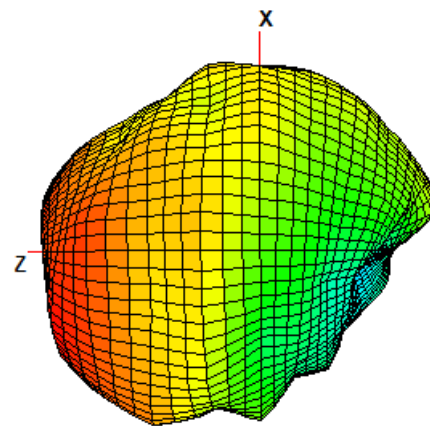

XZ-Plane

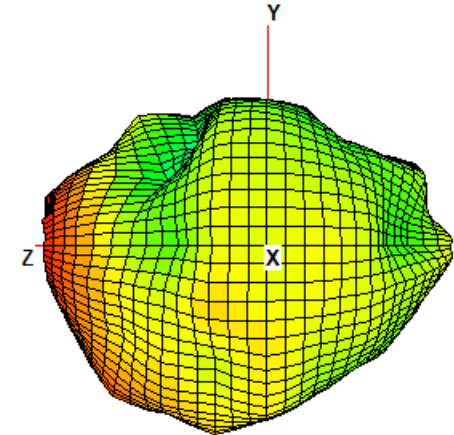

YZ-Plane

Case 4

	Tilt angle of lens	Rotation angle of lens holder
Case 1	0 degree	0 degree
Case 2	Middle angle	0 degree
Case 3	Middle angle	180 degree
Case 4	Max angle	0 degree
Case 5	Max angle	180 degree

Case 4 : Return Loss – Ant 1

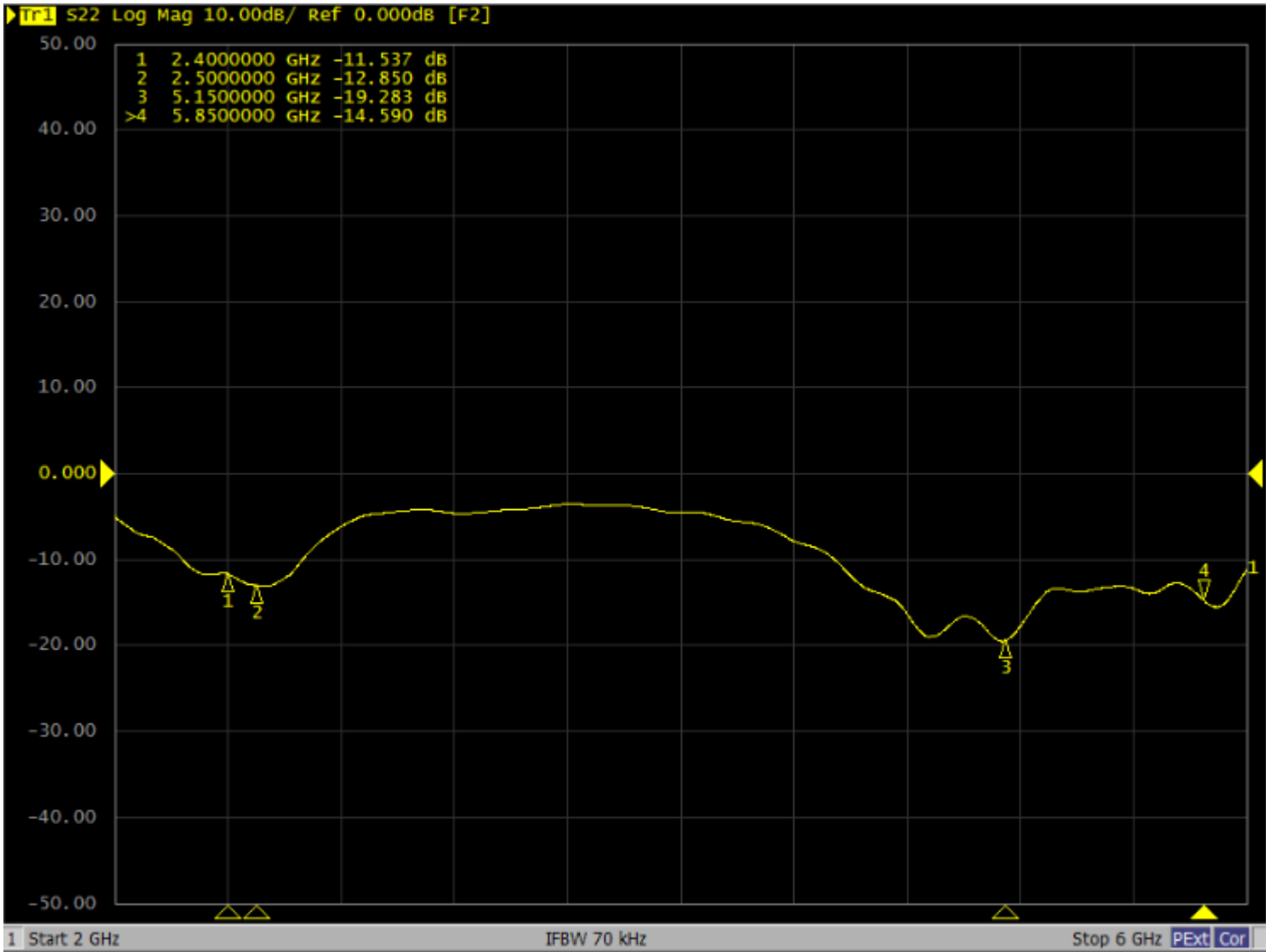

Case 4 : Return Loss – Ant 2

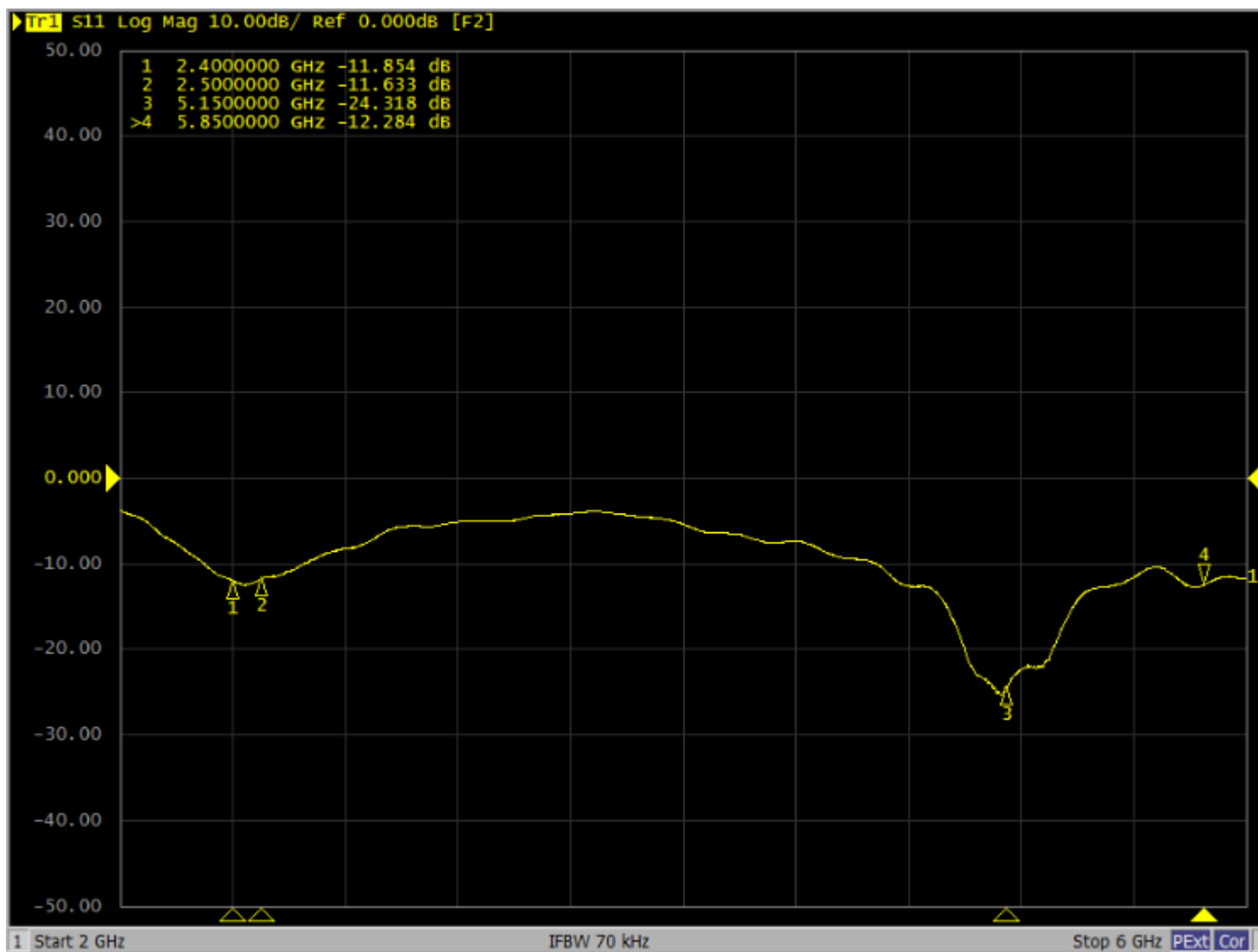

Case 4 : Radiation Pattern – Ant 1 @WiFi 2.4G/BT

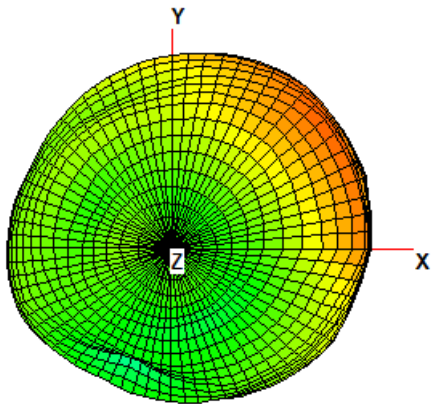
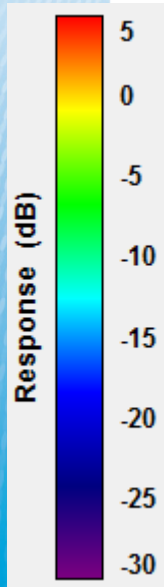

XY-Plane

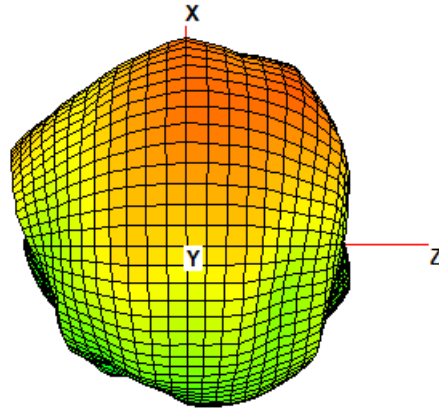

XZ-Plane

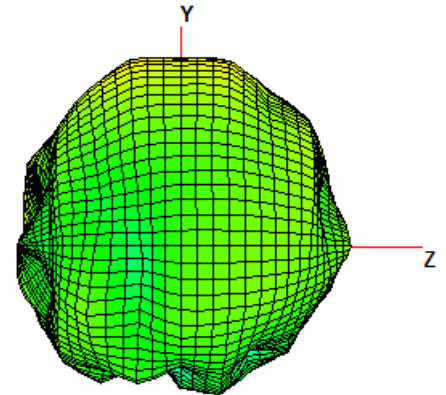

YZ-Plane

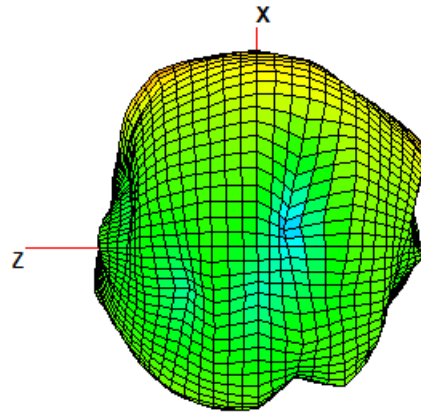

XZ-Plane

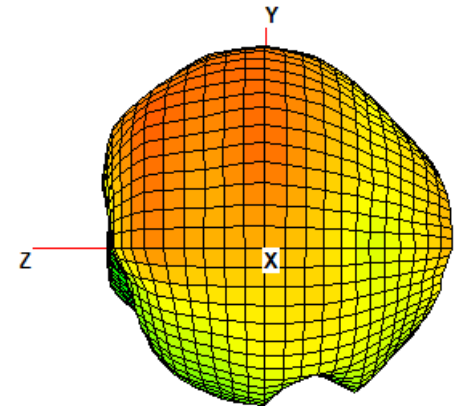

YZ-Plane

Case 4 : Radiation Pattern – Ant 1 @WiFi 5G

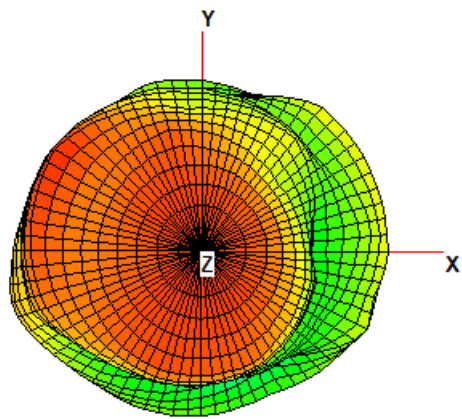
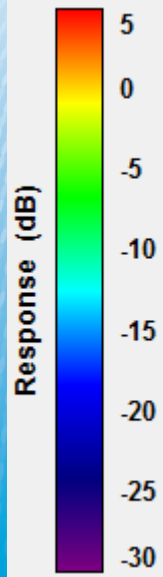

XY-Plane

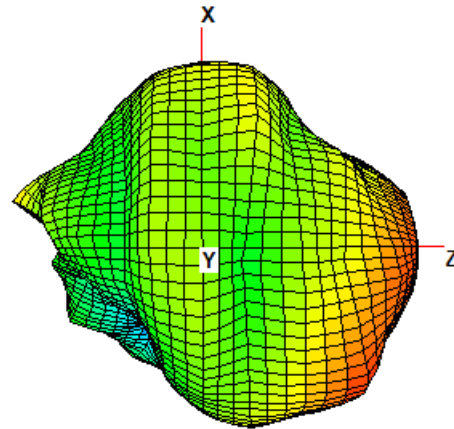

XZ-Plane

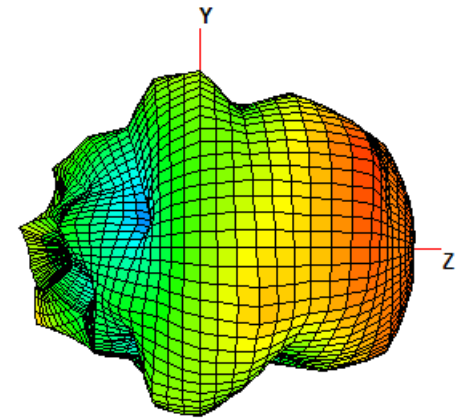

YZ-Plane

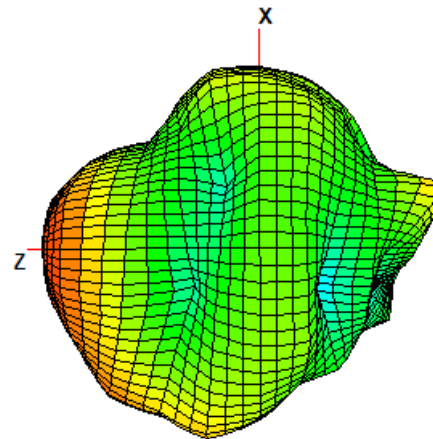

XZ-Plane

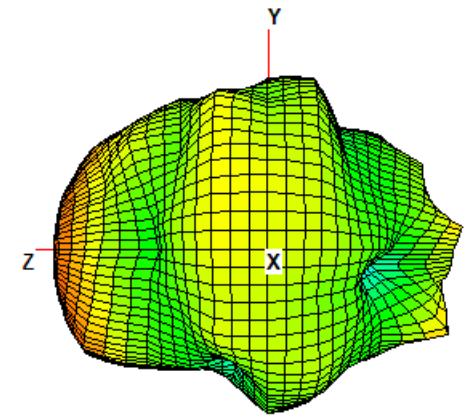

YZ-Plane

Case 4 : Radiation Pattern – Ant 2 @WiFi 2.4G/BT

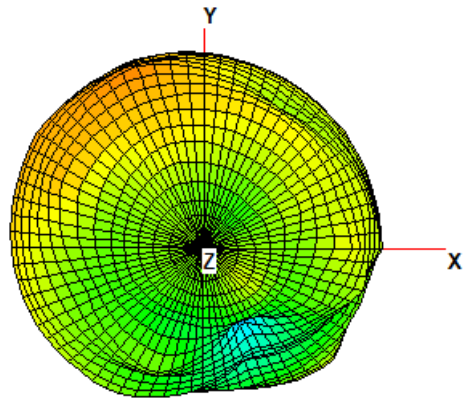
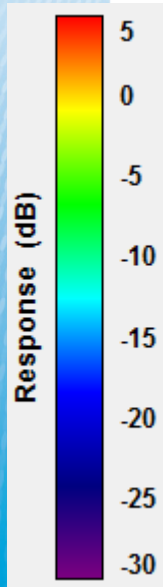

XY-Plane

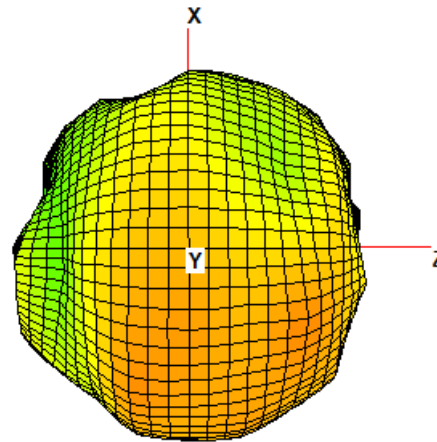

XZ-Plane

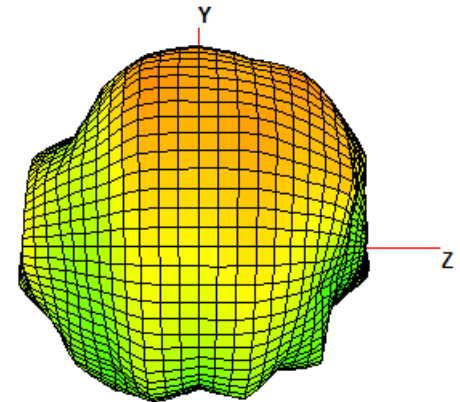

YZ-Plane

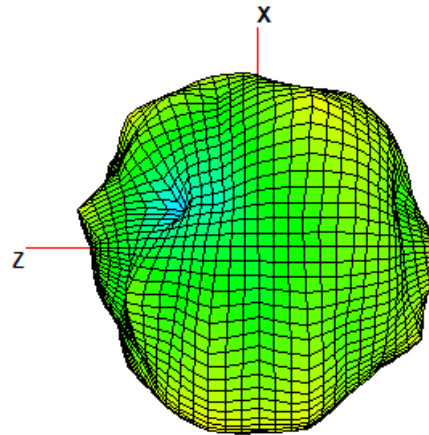

XZ-Plane

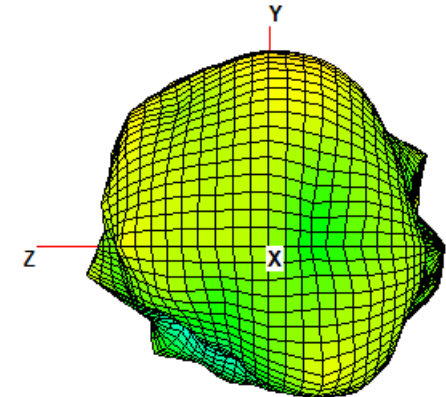

YZ-Plane

Case 4 : Radiation Pattern – Ant 2 @WiFi 5G

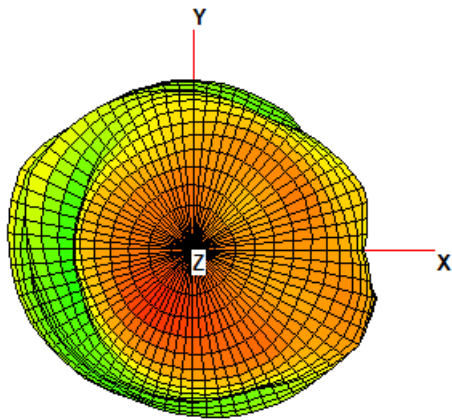
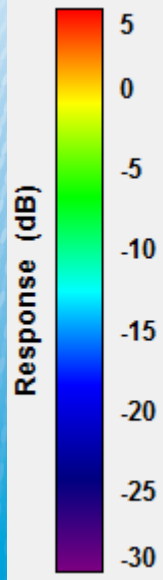

XY-Plane

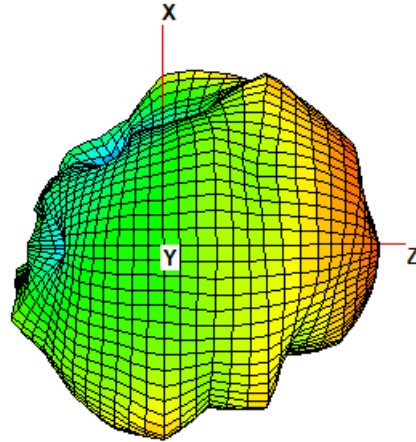

XZ-Plane

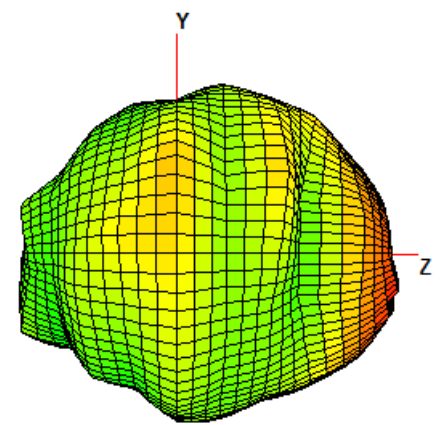

YZ-Plane

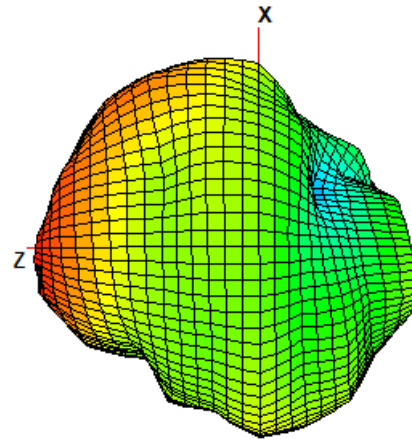

XZ-Plane

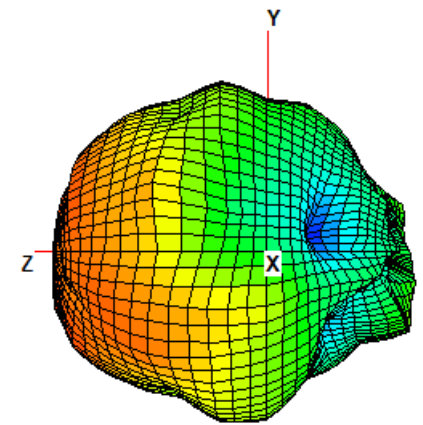

YZ-Plane

Case 5

	Tilt angle of lens	Rotation angle of lens holder
Case 1	0 degree	0 degree
Case 2	Middle angle	0 degree
Case 3	Middle angle	180 degree
Case 4	Max angle	0 degree
Case 5	Max angle	180 degree

Case 5 : Return Loss – Ant 1

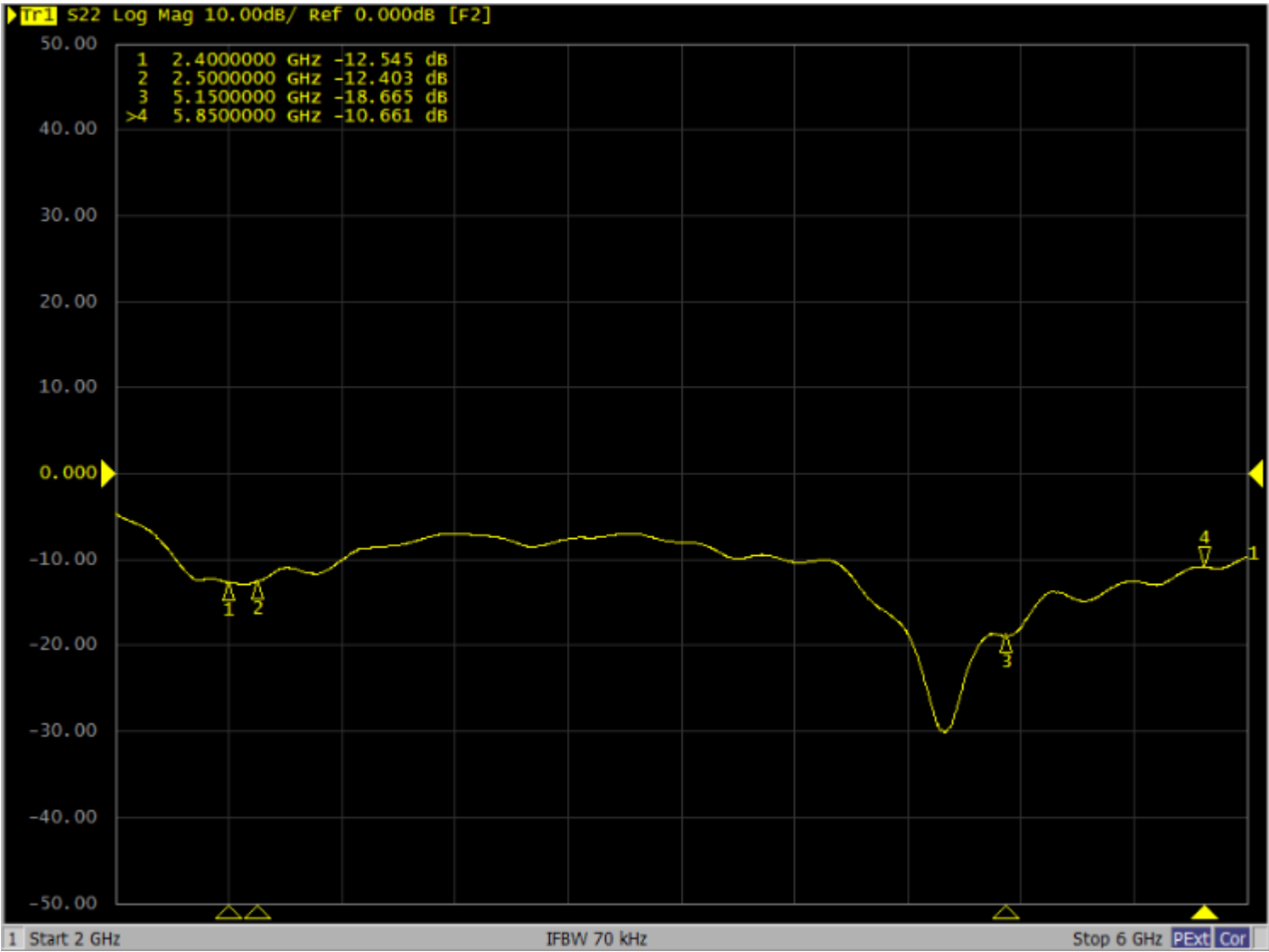

Case 5 : Return Loss – Ant 2

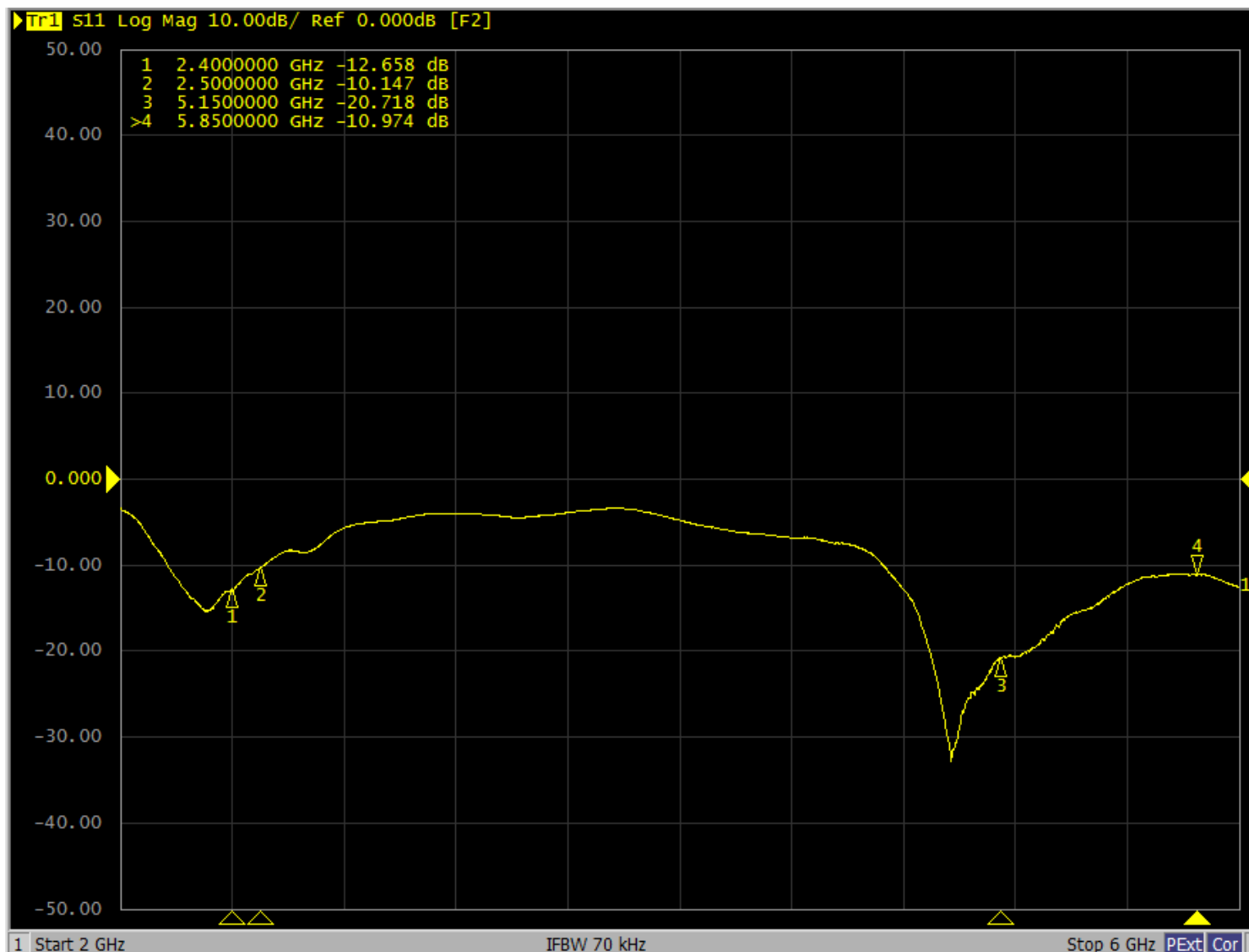

Case 5 : Isolation – Ant 1 & Ant 2

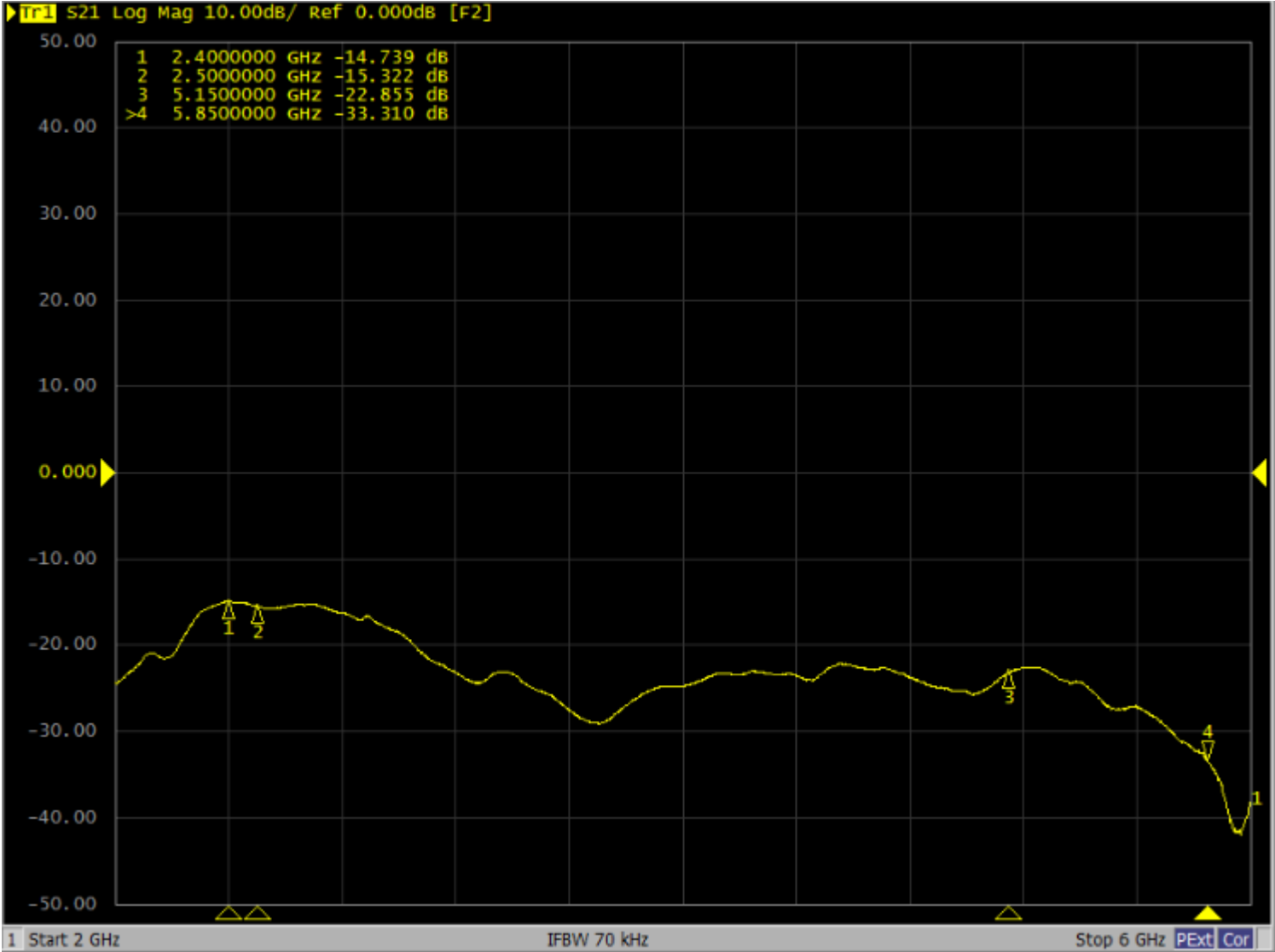

Case 5 : Radiation Pattern – Ant 1 @WiFi 2.4G/BT

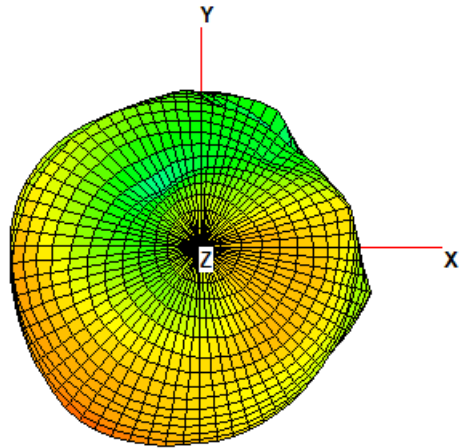
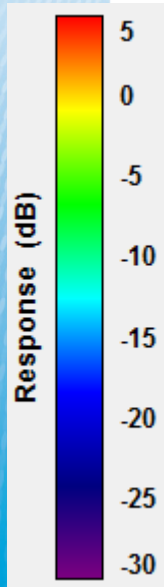

XY-Plane

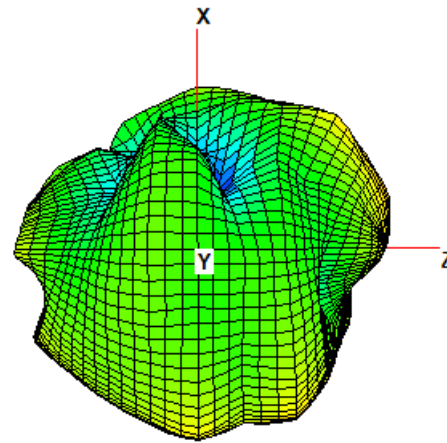

XZ-Plane

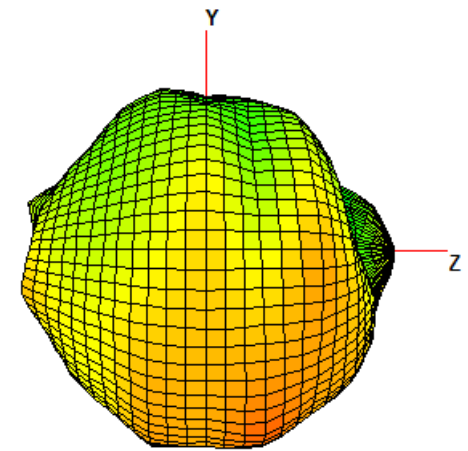

YZ-Plane

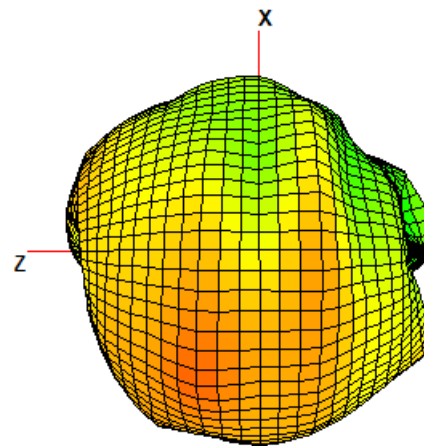

XZ-Plane

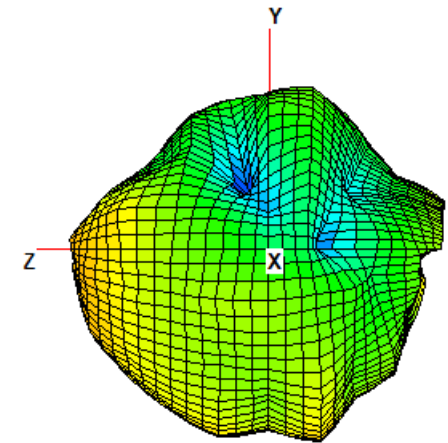

YZ-Plane

Case 5 : Radiation Pattern – Ant 1 @WiFi 5G

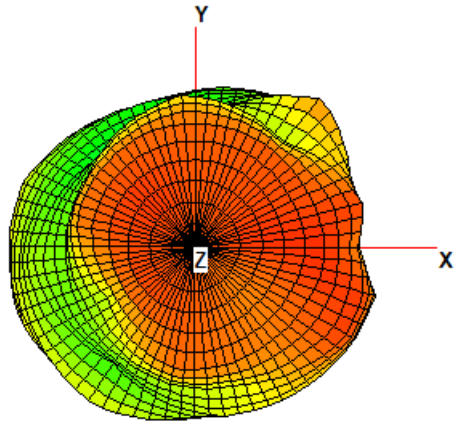
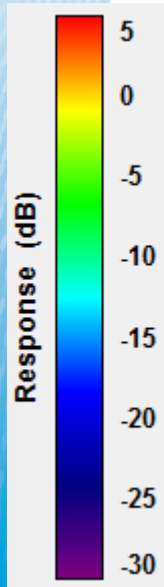

XY-Plane

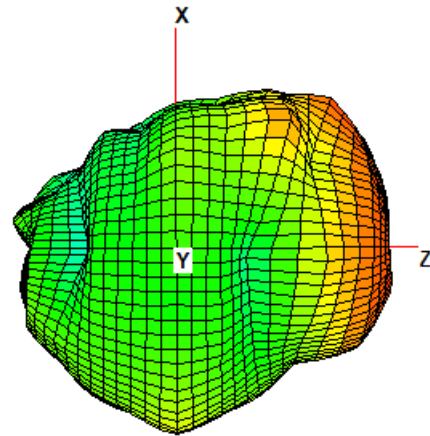

XZ-Plane

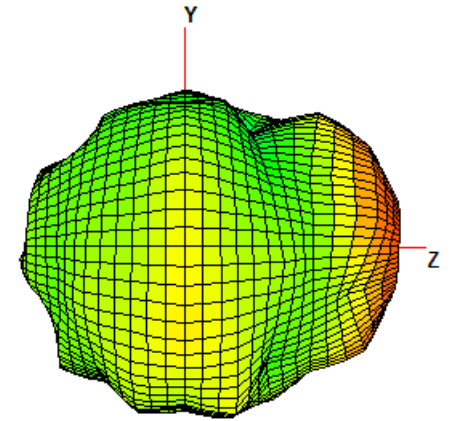

YZ-Plane

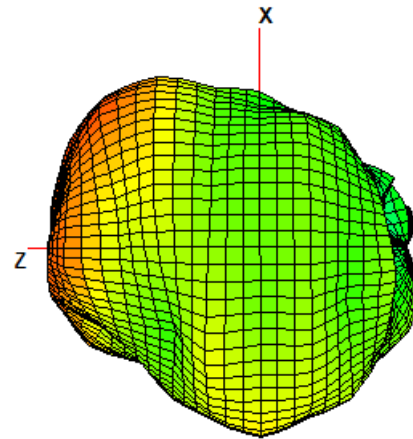

XZ-Plane

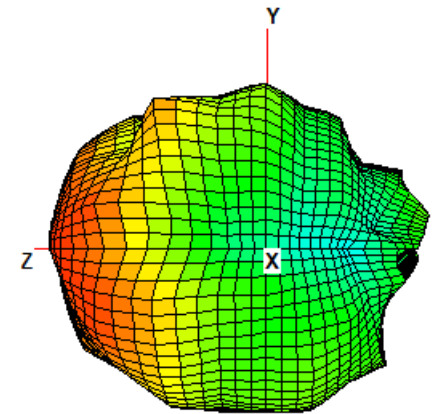

YZ-Plane

Case 5 : Radiation Pattern – Ant 2 @WiFi 2.4G/BT

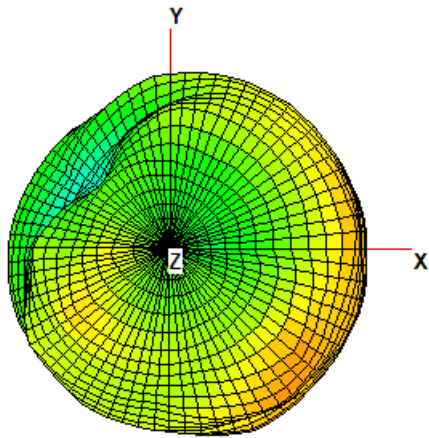
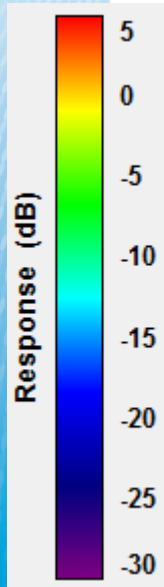

XY-Plane

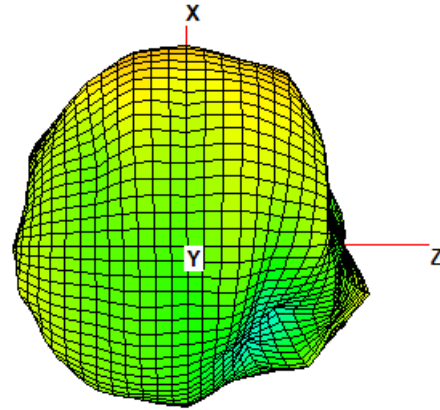

XZ-Plane

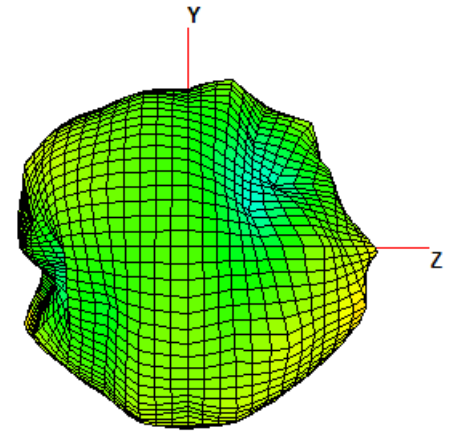

YZ-Plane

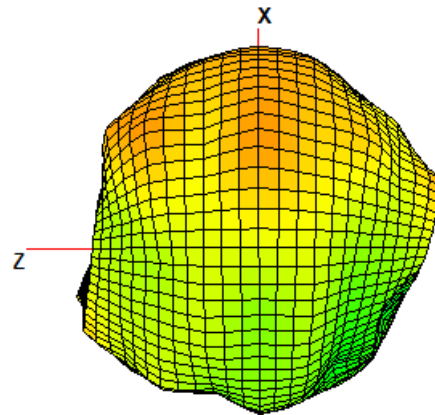

XZ-Plane

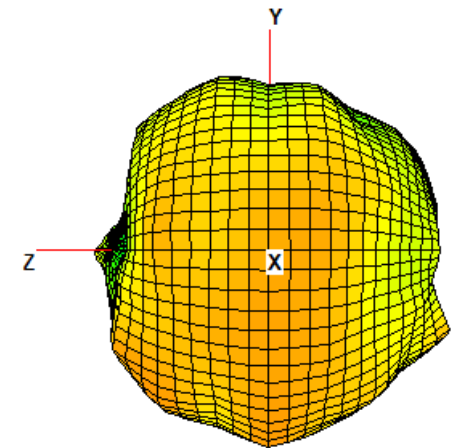

YZ-Plane

Case 5 : Radiation Pattern – Ant 2 @WiFi 5G

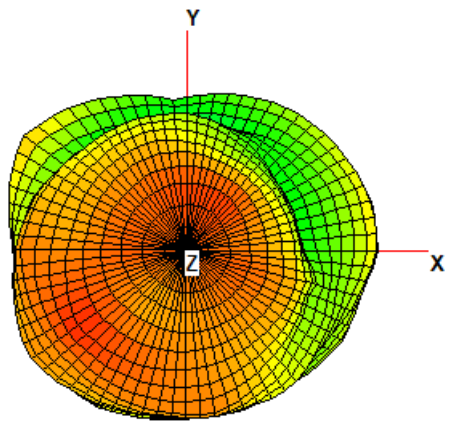
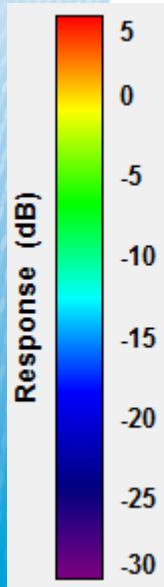

XY-Plane

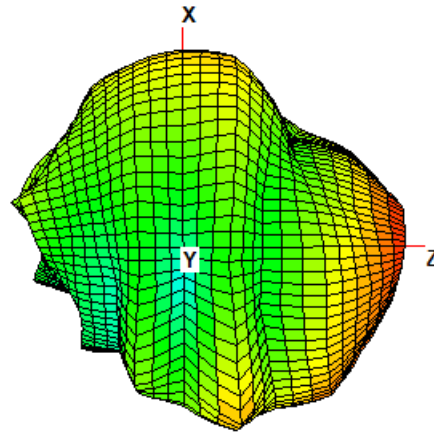

XZ-Plane

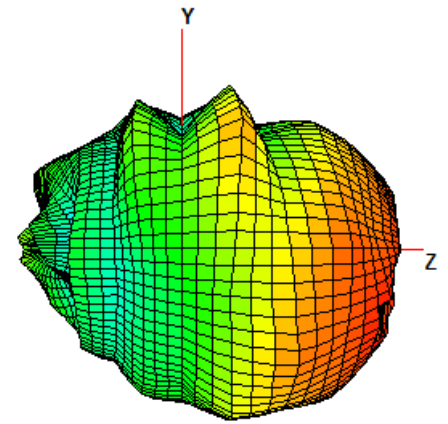

YZ-Plane

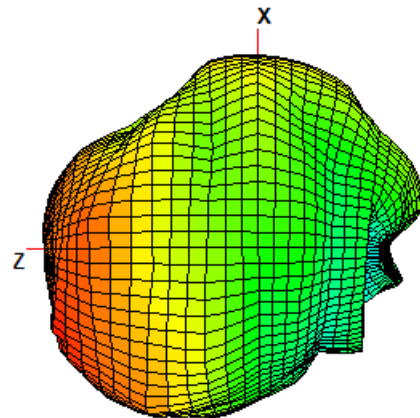

XZ-Plane

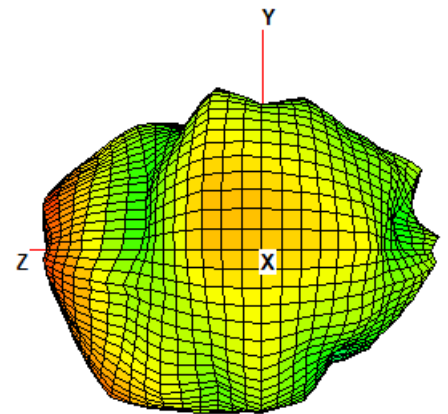

YZ-Plane

Case 1 : Peak Gain & Efficiency

Ant 1			
Frequency (MHz)	Peak Gain (dBi)	Efficiency (%)	Avg. Gain (dB)
2400	1.09	51.0	-2.92
2450	1.04	51.8	-2.86
2500	1.25	54.6	-2.63
5150	5.17	60.3	-2.20
5500	4.47	53.0	-2.76
5850	3.96	53.6	-2.71

Ant 2			
Frequency (MHz)	Peak Gain (dBi)	Efficiency (%)	Avg. Gain (dB)
2400	1.02	50.6	-2.96
2450	1.20	51.2	-2.91
2500	1.60	54.7	-2.62
5150	5.07	66.8	-1.75
5500	4.40	57.2	-2.43
5850	4.63	55.5	-2.56

Case 2 : Peak Gain & Efficiency

Ant 1			
Frequency (MHz)	Peak Gain (dBi)	Efficiency (%)	Avg. Gain (dB)
2400	1.96	52.7	-2.79
2450	2.14	53.5	-2.72
2500	2.44	54.6	-2.63
5150	4.63	54.0	-2.71
5500	3.96	53.4	-2.72
5850	4.54	56.3	-2.50

Ant 2			
Frequency (MHz)	Peak Gain (dBi)	Efficiency (%)	Avg. Gain (dB)
2400	1.51	50.0	-3.00
2450	1.83	53.9	-2.69
2500	2.28	57.5	-2.41
5150	5.31	69.0	-1.61
5500	6.64	62.7	-2.03
5850	5.48	52.6	-2.79

Case 3 : Peak Gain & Efficiency

Ant 1			
Frequency (MHz)	Peak Gain (dBi)	Efficiency (%)	Avg. Gain (dB)
2400	2.06	52.8	-2.77
2450	2.21	55.6	-2.55
2500	2.11	60.0	-2.22
5150	5.07	62.3	-2.05
5500	4.79	58.1	-2.36
5850	5.17	56.0	-2.52

Ant 2			
Frequency (MHz)	Peak Gain (dBi)	Efficiency (%)	Avg. Gain (dB)
2400	2.13	54.1	-2.67
2450	2.54	58.0	-2.36
2500	2.12	59.5	-2.25
5150	4.91	69.9	-1.56
5500	5.44	64.6	-1.90
5850	5.68	51.9	-2.85

Case 4 : Peak Gain & Efficiency

Ant 1			
Frequency (MHz)	Peak Gain (dBi)	Efficiency (%)	Avg. Gain (dB)
2400	3.18	56.0	-2.52
2450	3.13	58.7	-2.31
2500	3.38	62.3	-2.06
5150	5.50	57.5	-2.41
5500	4.35	57.2	-2.43
5850	3.99	60.4	-2.19

Ant 2			
Frequency (MHz)	Peak Gain (dBi)	Efficiency (%)	Avg. Gain (dB)
2400	2.27	54.3	-2.65
2450	2.18	59.7	-2.24
2500	2.37	63.3	-1.98
5150	5.33	60.3	-2.19
5500	5.43	58.8	-2.31
5850	4.74	53.8	-2.69

Case 5 : Peak Gain & Efficiency

Ant 1			
Frequency (MHz)	Peak Gain (dBi)	Efficiency (%)	Avg. Gain (dB)
2400	2.39	54.8	-2.61
2450	3.16	58.8	-2.31
2500	3.14	63.5	-1.98
5150	4.86	63.1	-2.00
5500	4.00	57.7	-2.39
5850	4.57	53.5	-2.72

Ant 2			
Frequency (MHz)	Peak Gain (dBi)	Efficiency (%)	Avg. Gain (dB)
2400	2.04	56.0	-2.52
2450	2.07	59.5	-2.25
2500	2.39	63.1	-2.00
5150	5.19	66.8	-1.75
5500	5.45	62.3	-2.05
5850	5.05	55.4	-2.57

Peak Gain & Efficiency Comparison

Ant 1 : Peak Gain & Efficiency Comparison

Ant 1 Peak Gain (dBi)					
Frequency (MHz)	Case 1	Case 2	Case 3	Case 4	Case 5
2400	1.09	1.96	2.06	3.18	2.39
2450	1.04	2.14	2.21	3.13	3.16
2500	1.25	2.44	2.11	3.38	3.14
5150	5.17	4.63	5.07	5.50	4.86
5500	4.47	3.96	4.79	4.35	4.00
5850	3.96	4.54	5.17	3.99	4.57

Ant 1 Efficiency (%)					
Frequency (MHz)	Case 1	Case 2	Case 3	Case 4	Case 5
2400	51.0	52.7	52.8	56.0	54.8
2450	51.8	53.5	55.6	58.7	58.8
2500	54.6	54.6	60.0	62.3	63.5
5150	60.3	54.0	62.3	57.5	63.1
5500	53.0	53.4	58.1	57.2	57.7
5850	53.6	56.3	56.0	60.4	53.5



Ant 1 : Avg. Gain Comparison

Ant 1 Avg. Gain (dB)					
Frequency (MHz)	Case 1	Case 2	Case 3	Case 4	Case 5
2400	-2.92	-2.79	-2.77	-2.52	-2.61
2450	-2.86	-2.72	-2.55	-2.31	-2.31
2500	-2.63	-2.63	-2.22	-2.06	-1.98
5150	-2.20	-2.71	-2.05	-2.41	-2.00
5500	-2.76	-2.72	-2.36	-2.43	-2.39
5850	-2.71	-2.50	-2.52	-2.19	-2.72

Ant 2 : Peak Gain & Efficiency Comparison

Ant 2 Peak Gain (dBi)					
Frequency (MHz)	Case 1	Case 2	Case 3	Case 4	Case 5
2400	1.02	1.51	2.13	2.27	2.04
2450	1.20	1.83	2.54	2.18	2.07
2500	1.60	2.28	2.12	2.37	2.39
5150	5.07	5.31	4.91	5.33	5.19
5500	4.40	6.64	5.44	5.43	5.45
5850	4.63	5.48	5.68	4.74	5.05

Ant 2 Efficiency (%)					
Frequency (MHz)	Case 1	Case 2	Case 3	Case 4	Case 5
2400	50.6	50.0	54.1	54.3	56.0
2450	51.2	53.9	58.0	59.7	59.5
2500	54.7	57.5	59.5	63.3	63.1
5150	66.8	69.0	69.9	60.3	66.8
5500	57.2	62.7	64.6	58.8	62.3
5850	55.5	52.6	51.9	53.8	55.4



Ant 2 : Avg. Gain Comparison

Ant 2 Avg. Gain (dB)					
Frequency (MHz)	Case 1	Case 2	Case 3	Case 4	Case 5
2400	-2.96	-3.00	-2.67	-2.65	-2.52
2450	-2.91	-2.69	-2.36	-2.24	-2.25
2500	-2.62	-2.41	-2.25	-1.98	-2.00
5150	-1.75	-1.61	-1.56	-2.19	-1.75
5500	-2.43	-2.03	-1.90	-2.31	-2.05
5850	-2.56	-2.79	-2.85	-2.69	-2.57

Pattern Comparison

Ant 1 @ 2.4G_XY-Plane

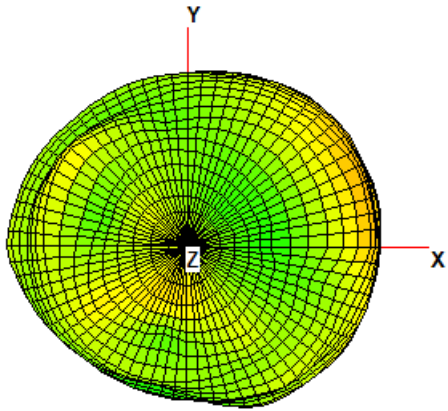
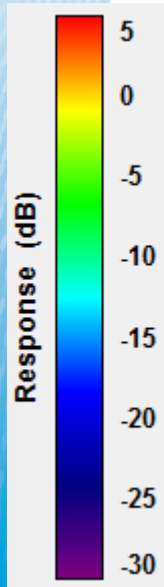

Case 1

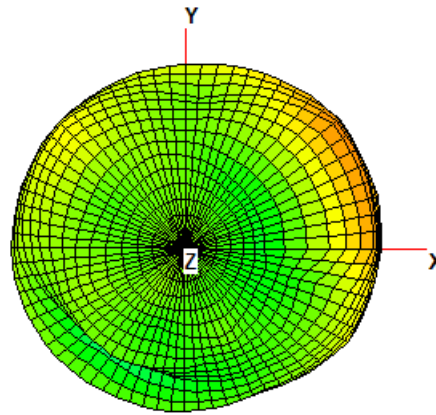

Case 2

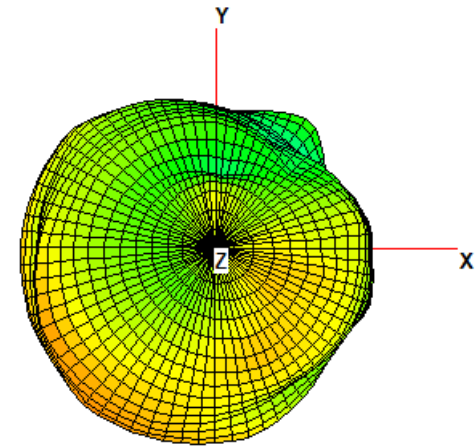

Case 3

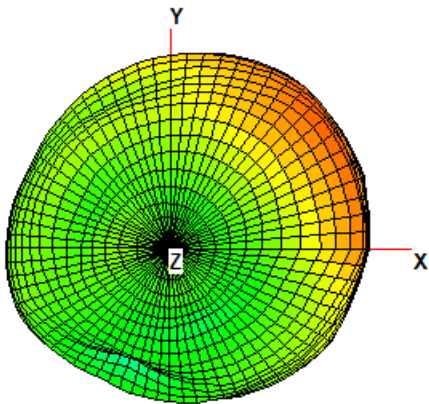

Case 4

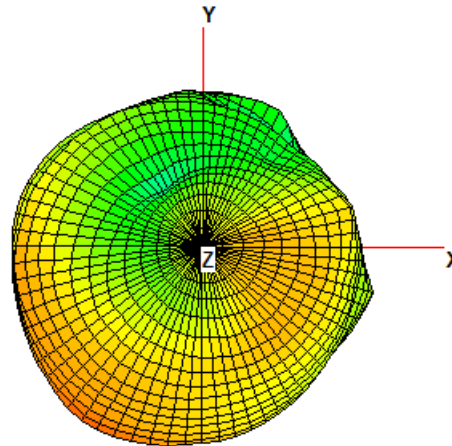

Case 5

Ant 1 @ 2.4G_XZ-Plane (View 1)

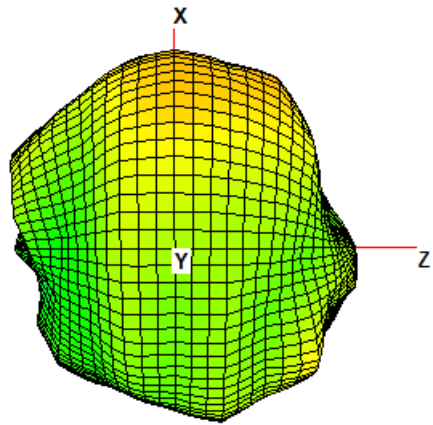
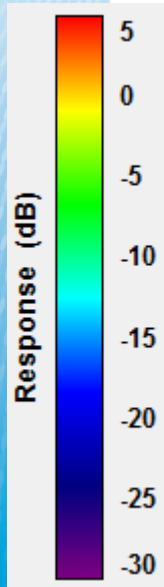

Case 1

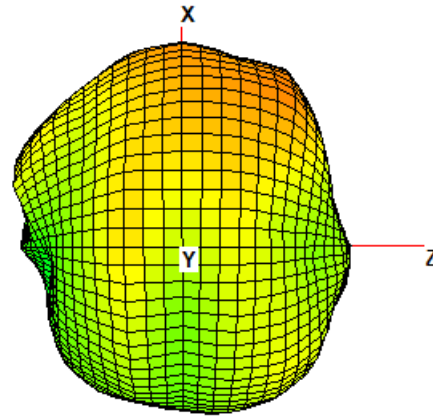

Case 2

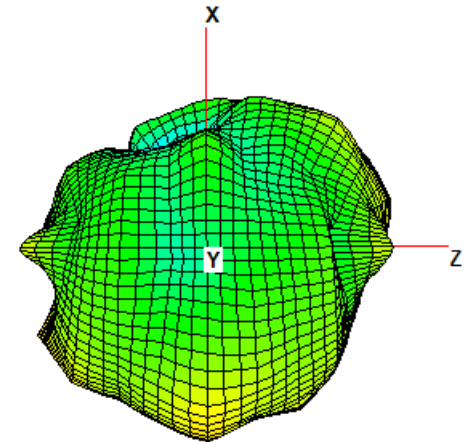

Case 3

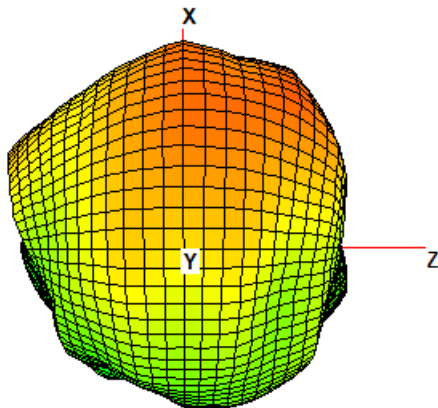

Case 4

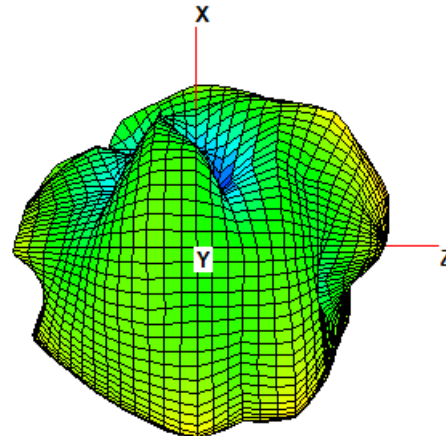

Case 5

Ant 1 @ 2.4G_XZ-Plane (View 2)

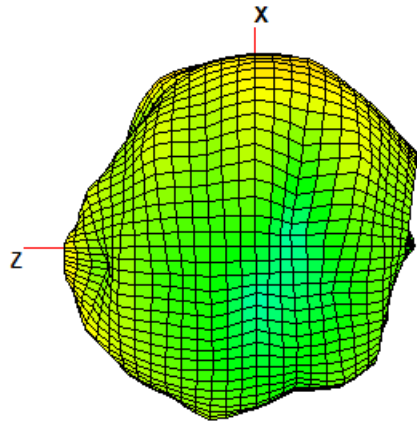
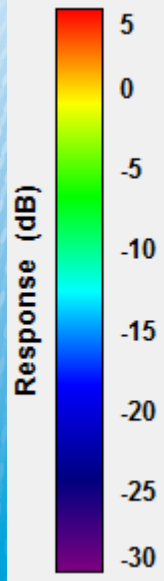

Case 1

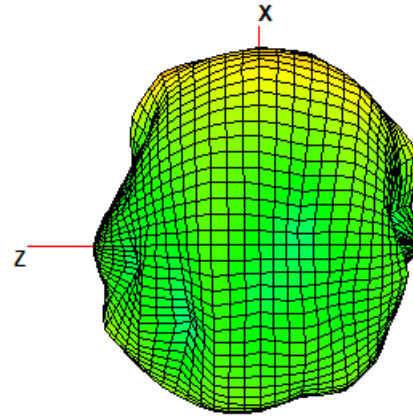

Case 2

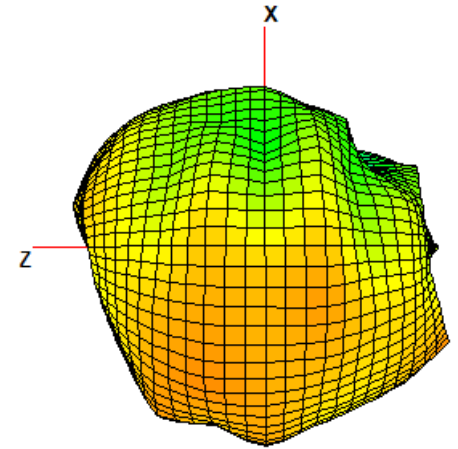

Case 3

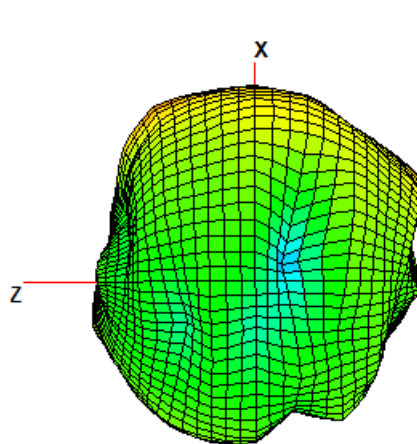

Case 4

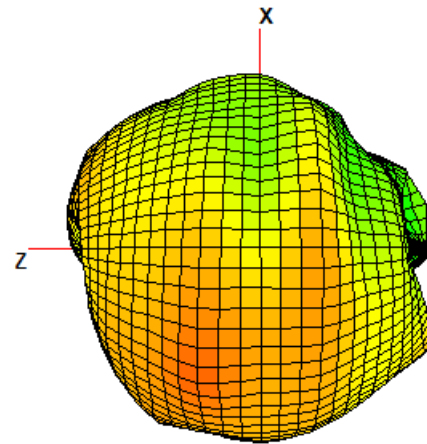

Case 5

Ant 1 @ 2.4G_YZ-Plane (View 1)

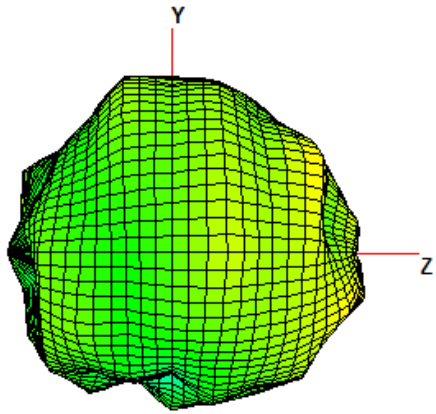
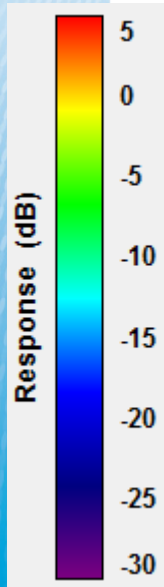

Case 1

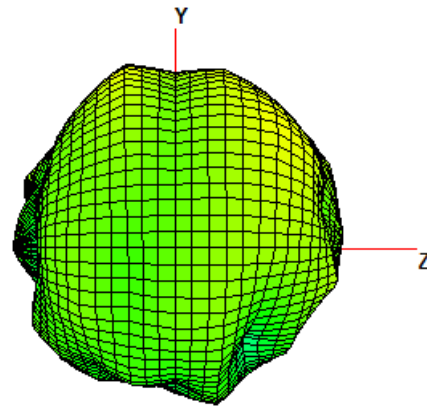

Case 2

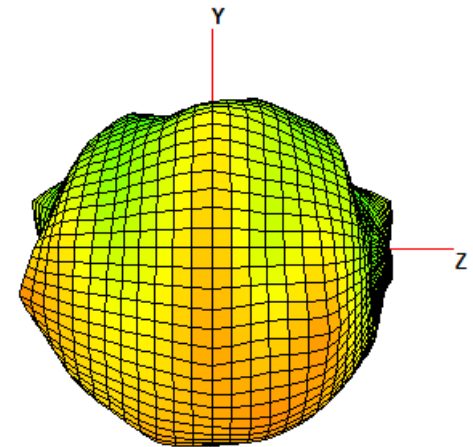

Case 3

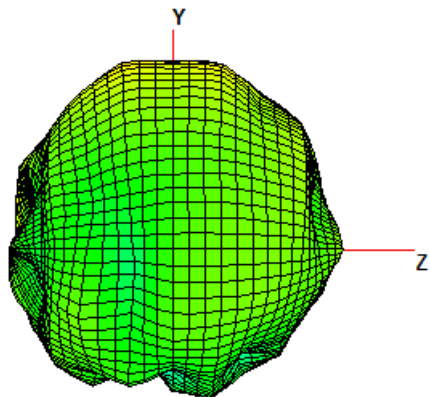

Case 4

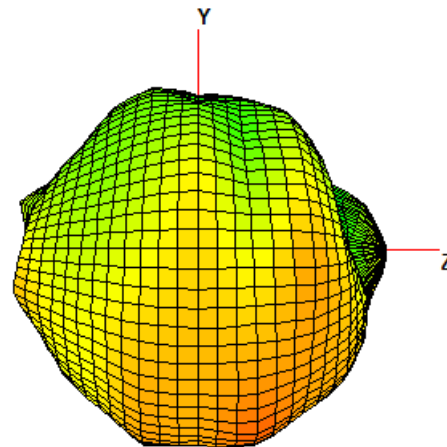

Case 5

Ant 1 @ 2.4G_YZ-Plane (View 2)

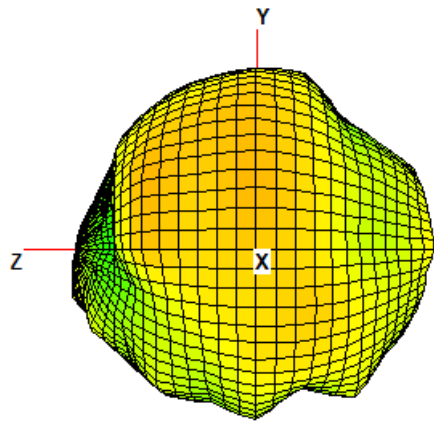
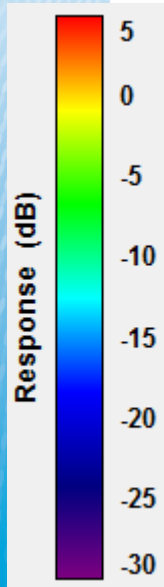

Case 1

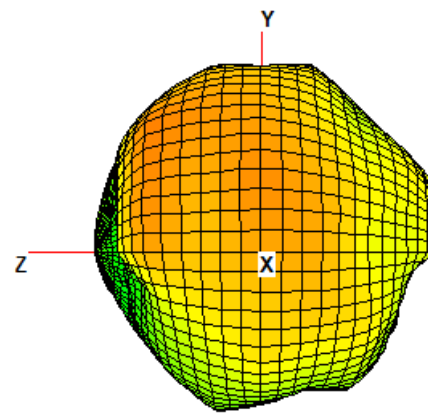

Case 2

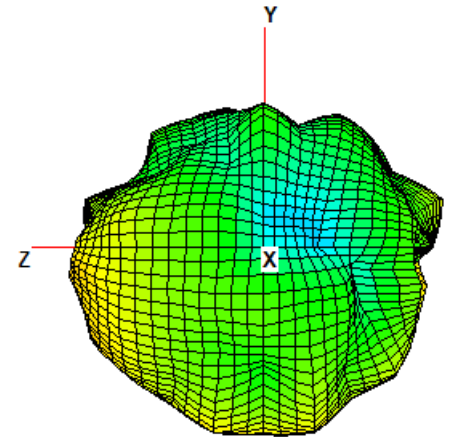

Case 3

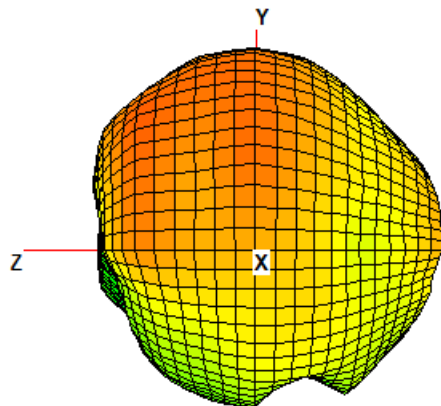

Case 4

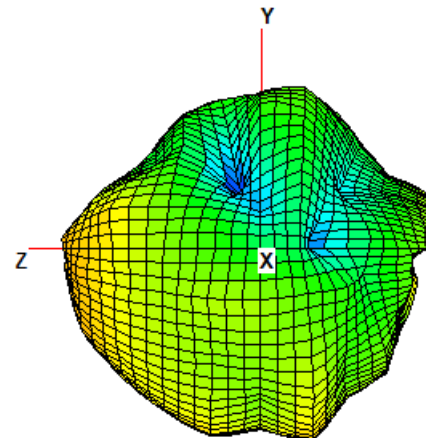

Case 5

Ant 1 @ 5G_XY-Plane

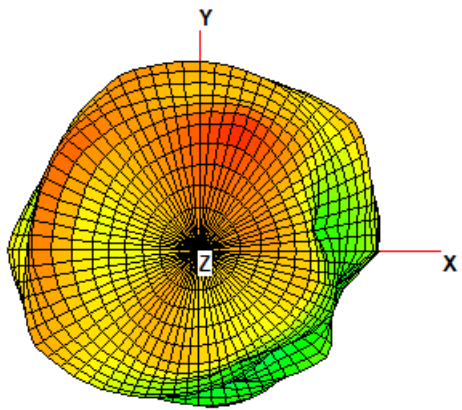
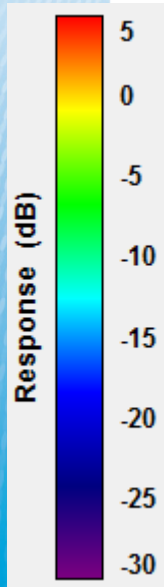

Case 1

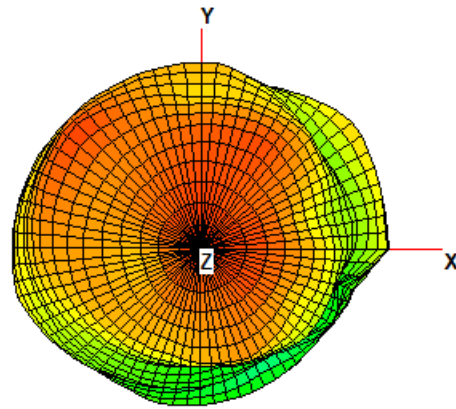

Case 2

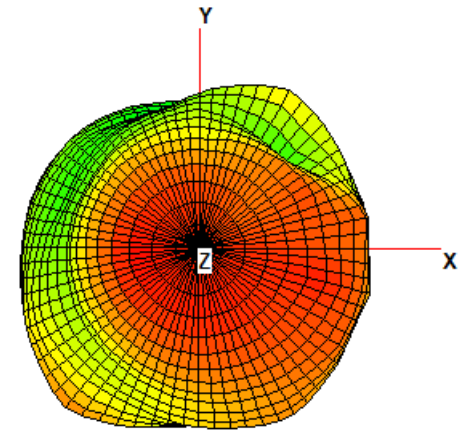

Case 3

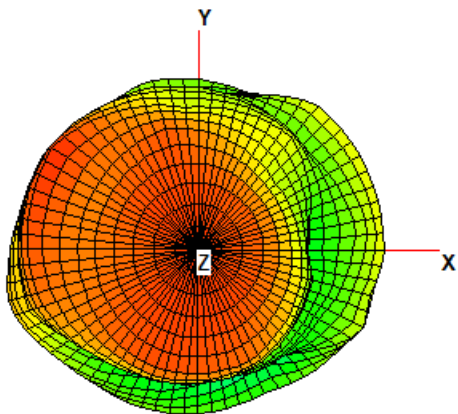

Case 4

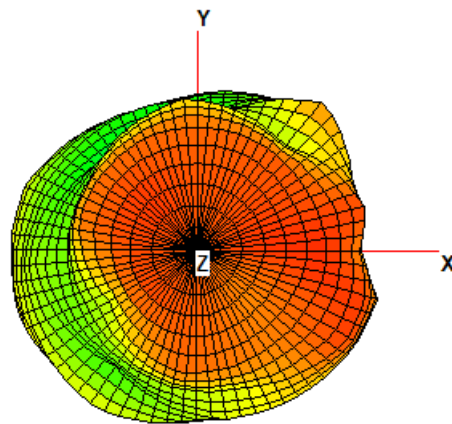

Case 5

Ant 1 @ 5G_XZ-Plane (View 1)

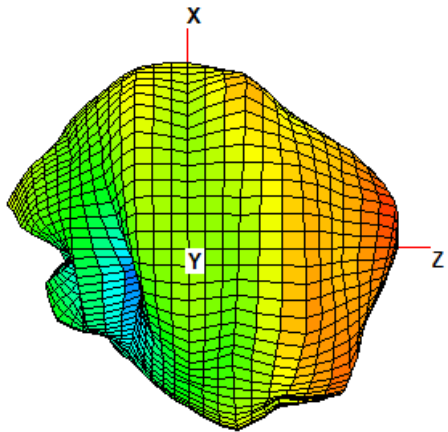
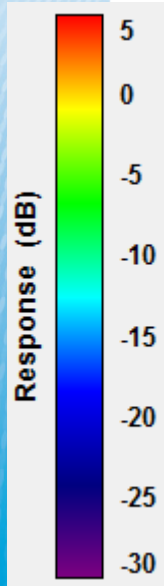

Case 1

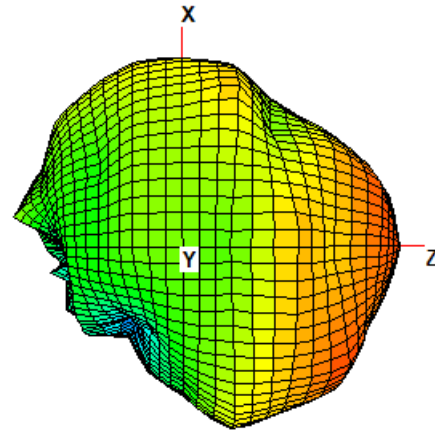

Case 2

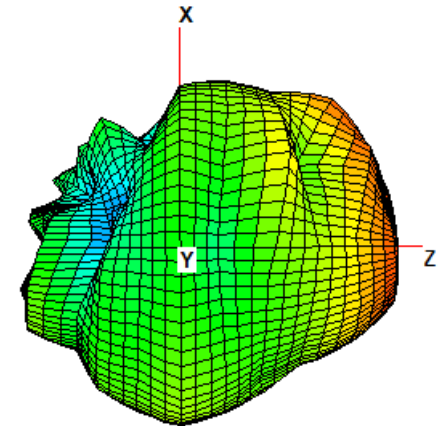

Case 3

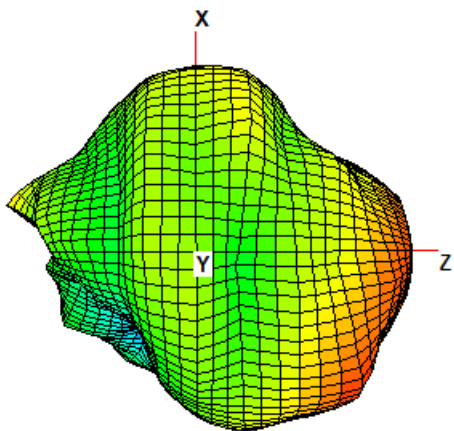

Case 4

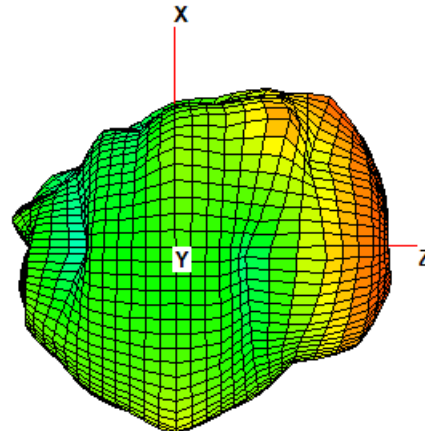

Case 5

Ant 1 @ 5G_XZ-Plane (View 2)

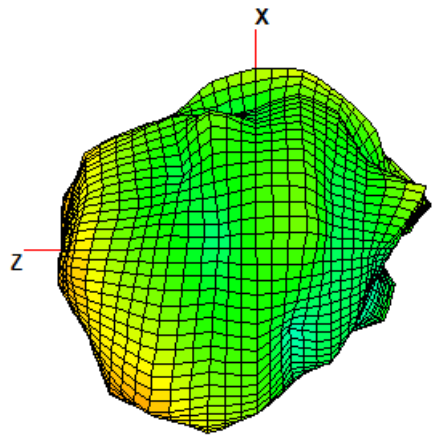
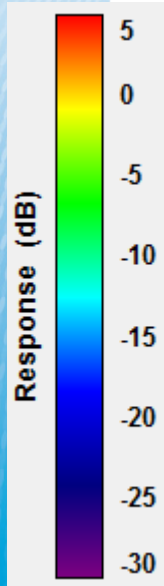

Case 1

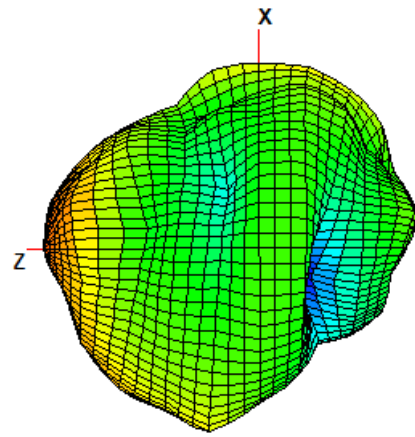

Case 2

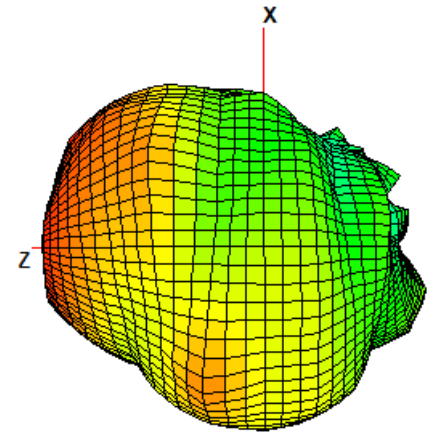

Case 3

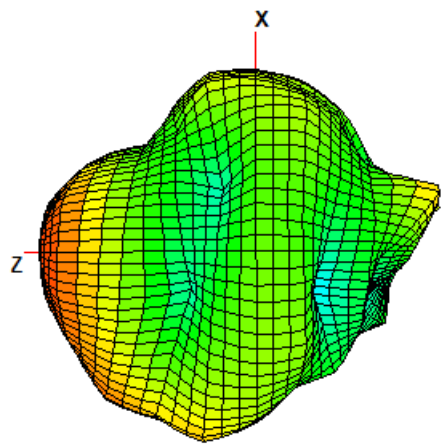

Case 4

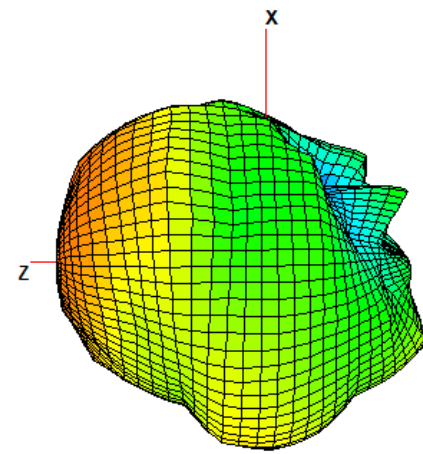

Case 5

Ant 1 @ 5G_YZ-Plane (View 1)

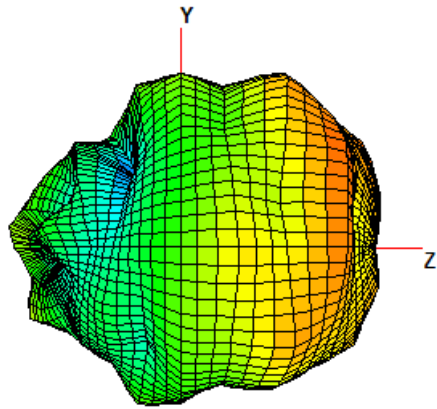
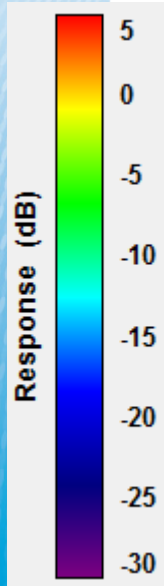

Case 1

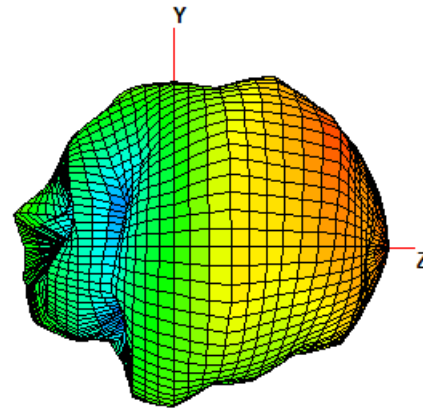

Case 2

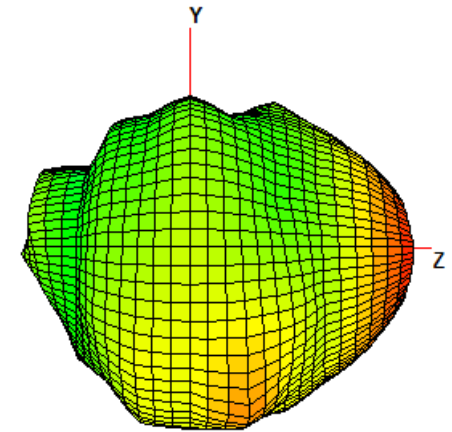

Case 3

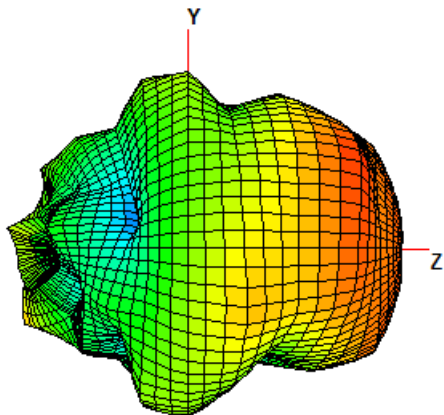

Case 4

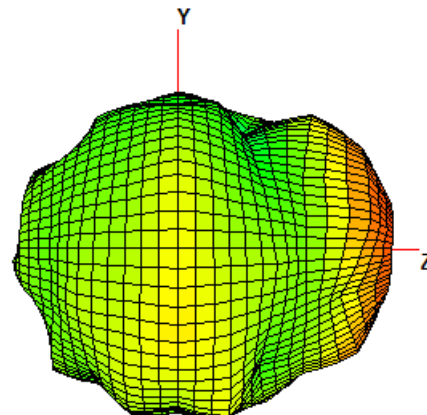

Case 5

Ant 1 @ 5G_YZ-Plane (View 2)

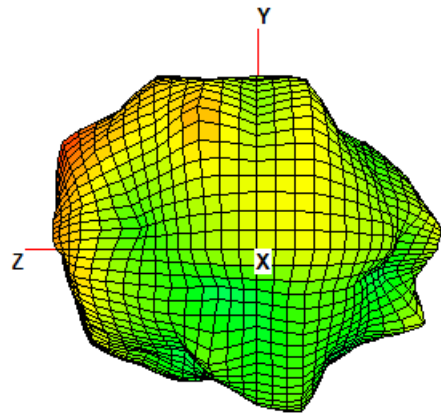
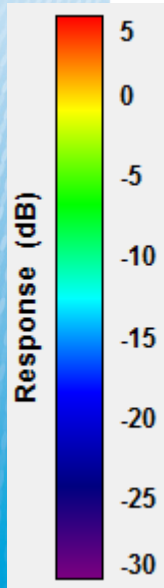

Case 1

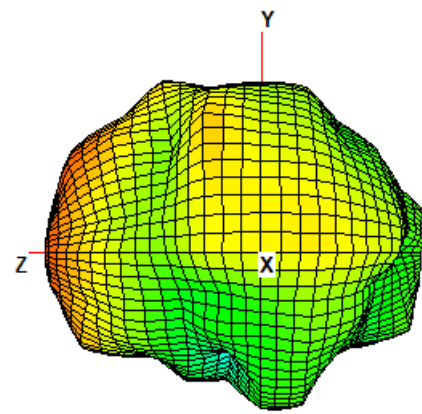

Case 2

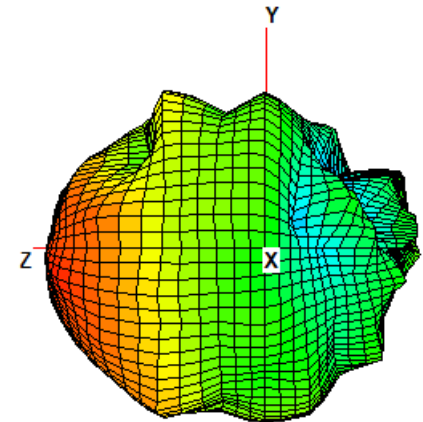

Case 3

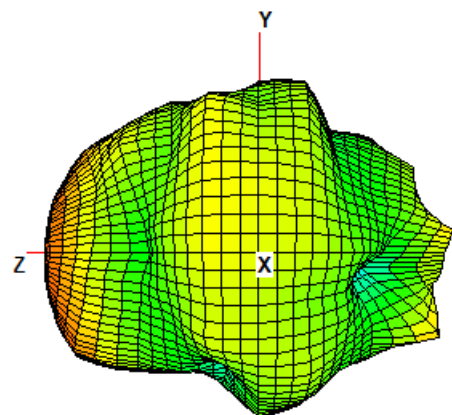

Case 4

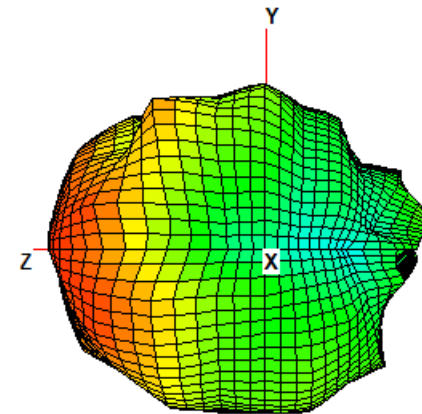

Case 5

Ant 2 @ 2.4G_XY-Plane

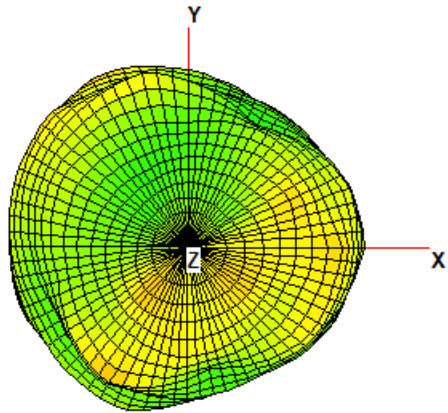
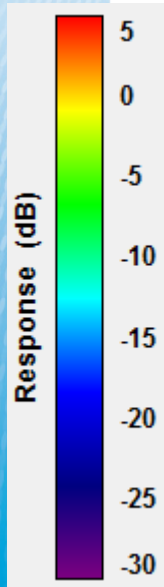

Case 1

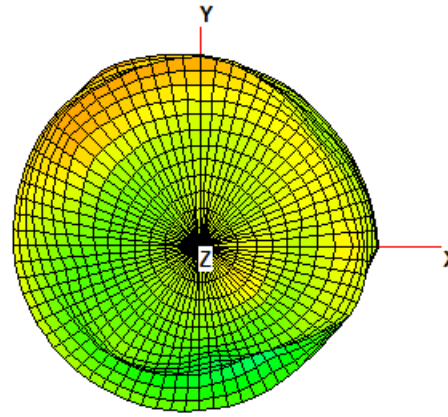

Case 2

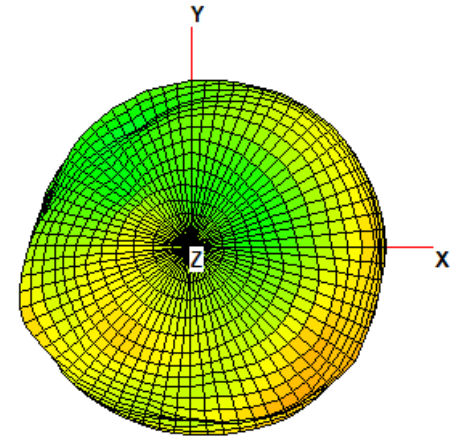

Case 3

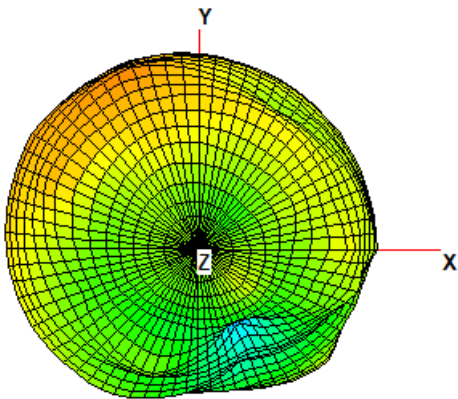

Case 4

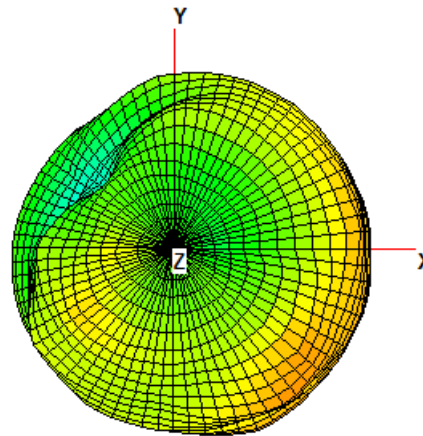

Case 5

Ant 2 @ 2.4G_XZ-Plane (View 1)

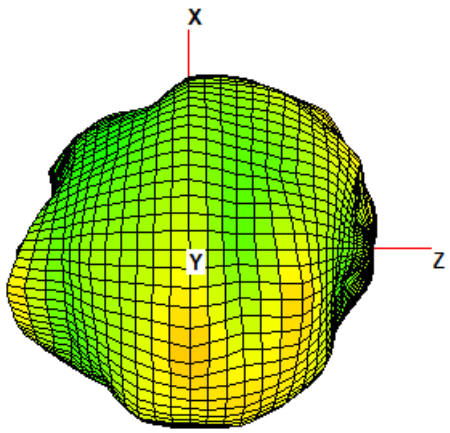
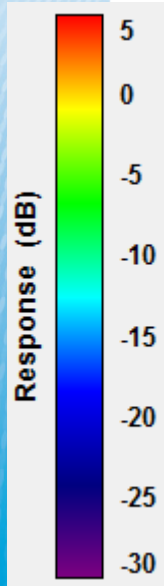

Case 1

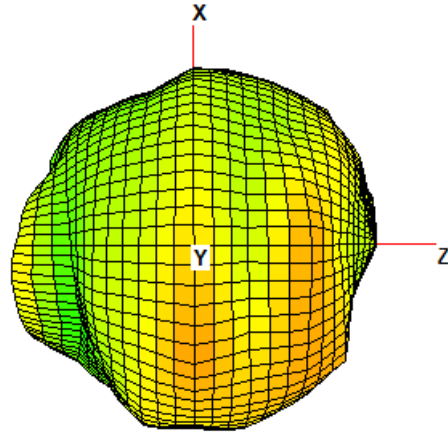

Case 2

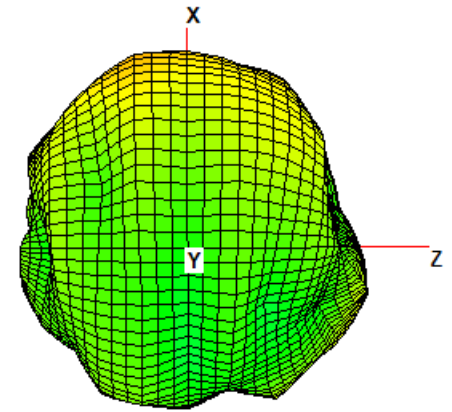

Case 3

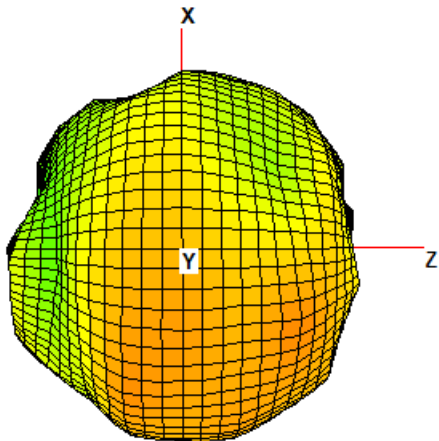

Case 4

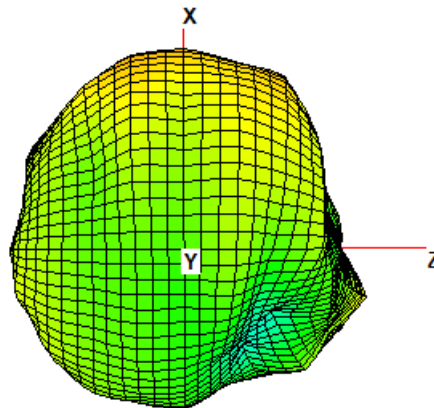

Case 5

Ant 2 @ 2.4G_XZ-Plane (View 2)

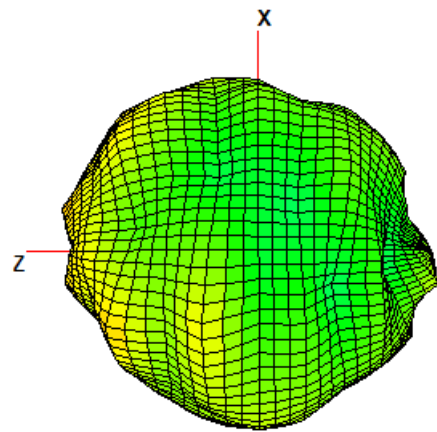
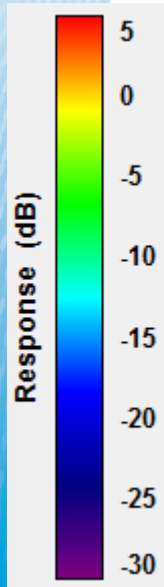

Case 1

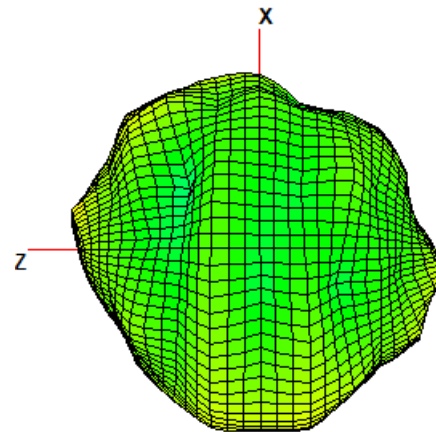

Case 2

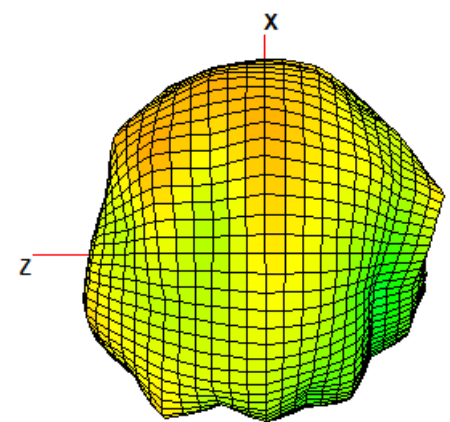

Case 3

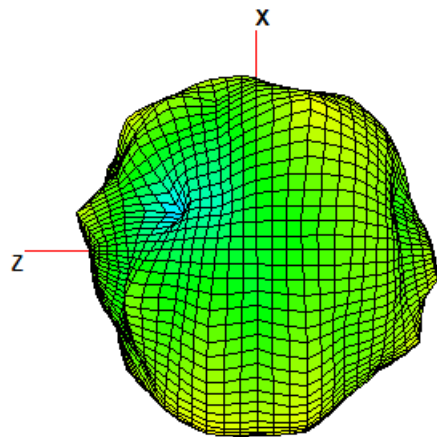

Case 4

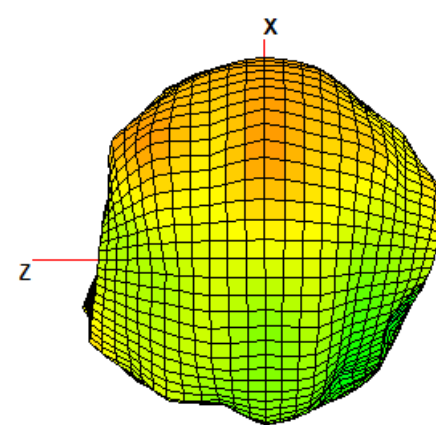

Case 5

Ant 2 @ 2.4G_YZ-Plane (View 1)

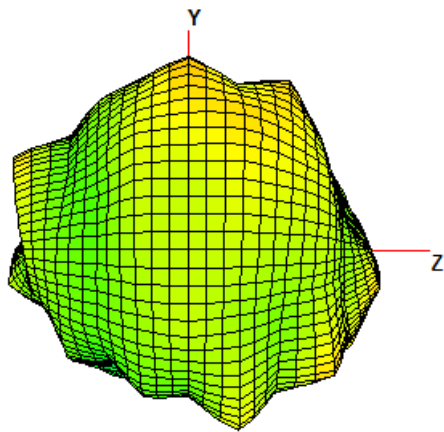
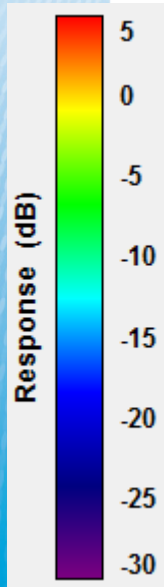

Case 1

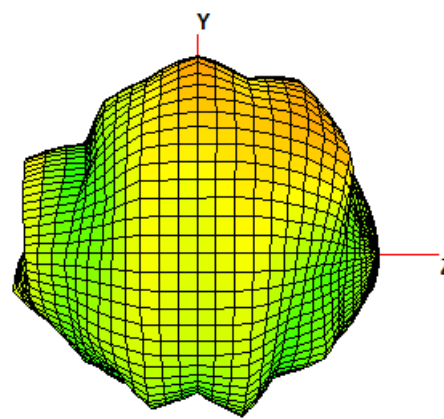

Case 2

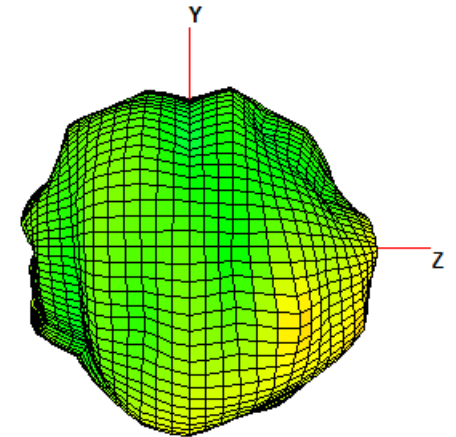

Case 3

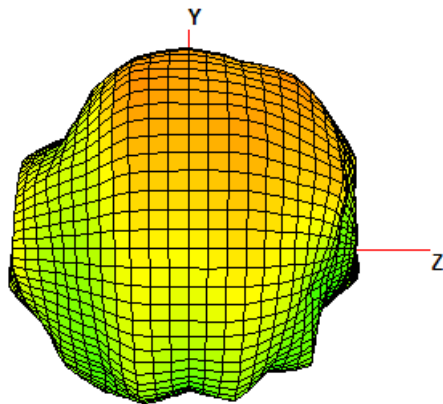

Case 4

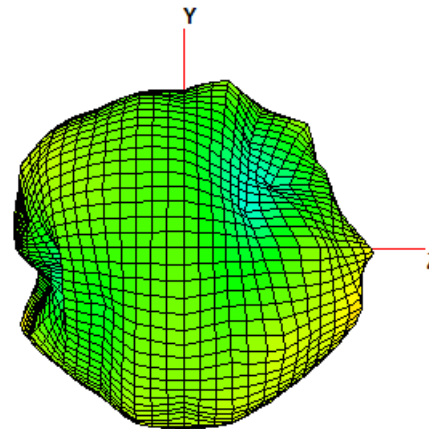

Case 5

Ant 2 @ 2.4G_YZ-Plane (View 2)

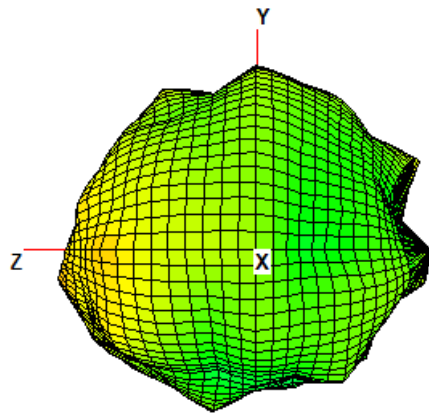
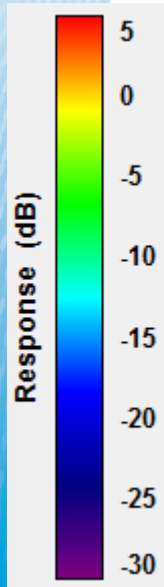

Case 1

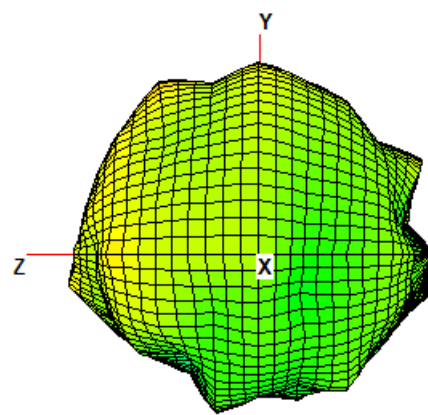

Case 2

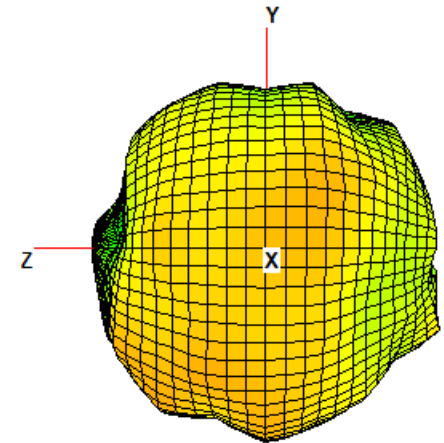

Case 3

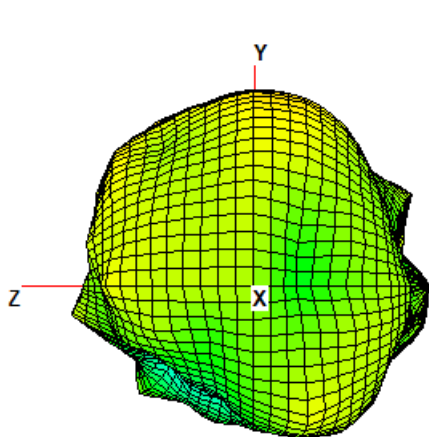

Case 4

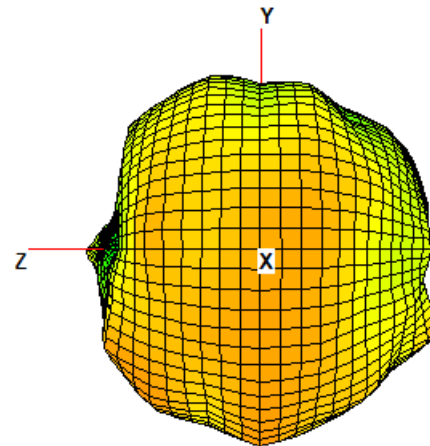

Case 5

Ant 2 @ 5G_XY-Plane

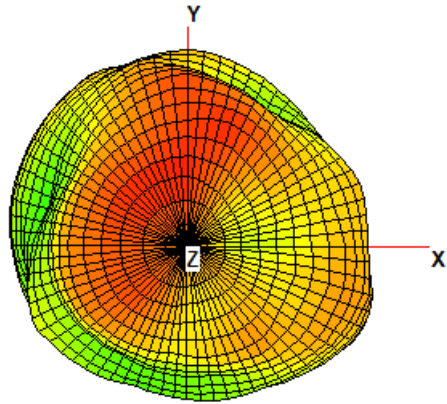
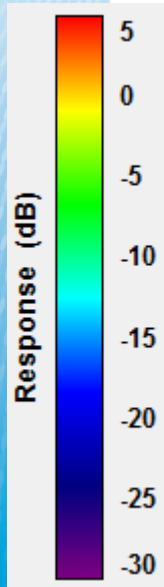

Case 1

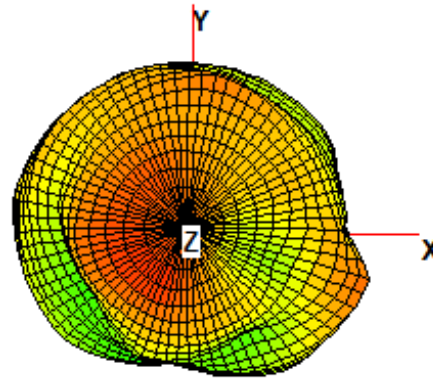

Case 2

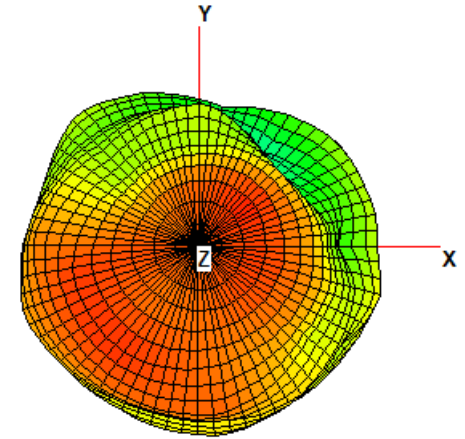

Case 3

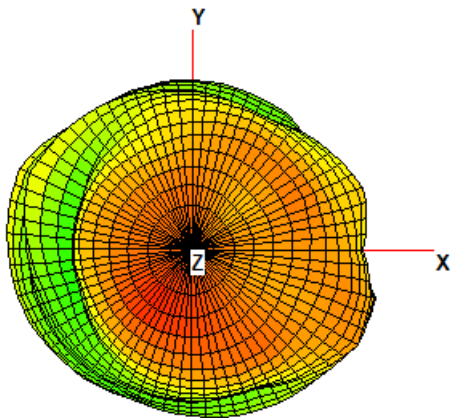

Case 4

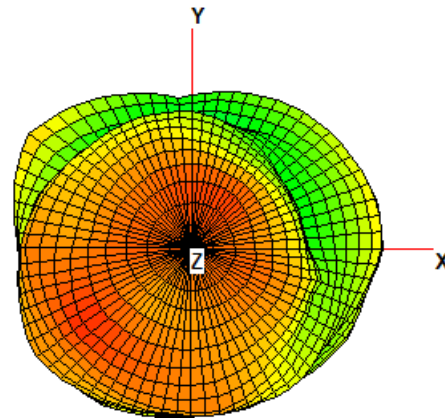

Case 5

Ant 2 @ 5G_XZ-Plane (View 1)

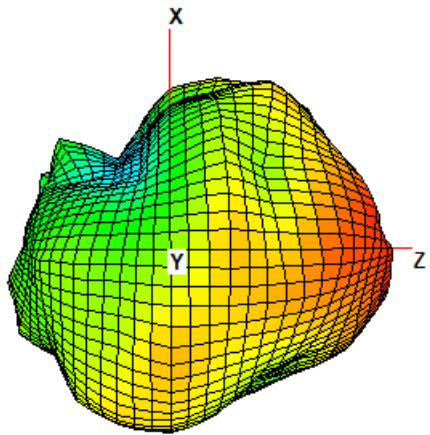
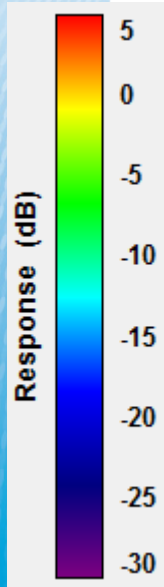

Case 1

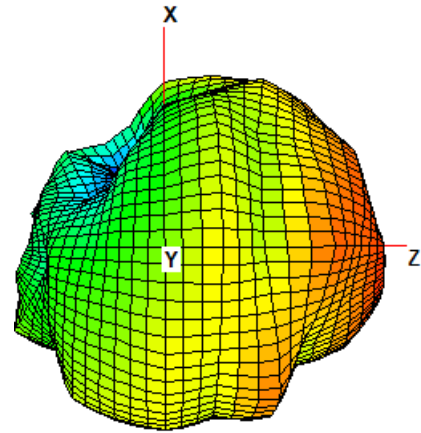

Case 2

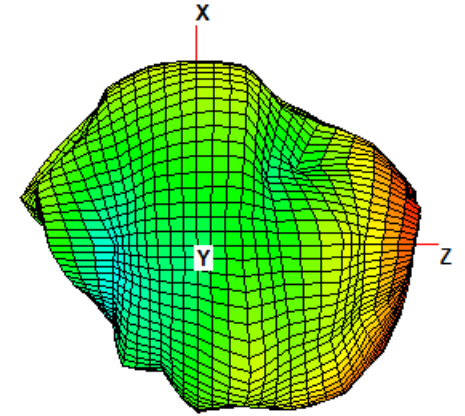

Case 3

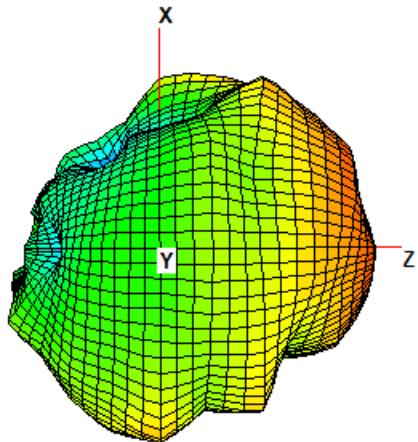

Case 4

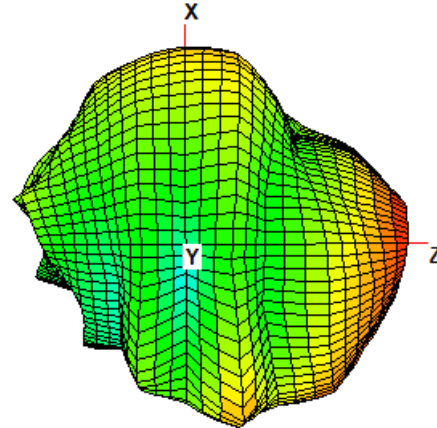

Case 5

Ant 2 @ 5G_XZ-Plane (View 2)

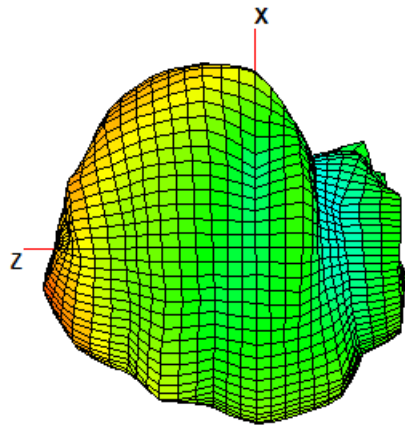
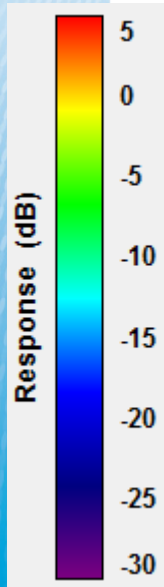

Case 1

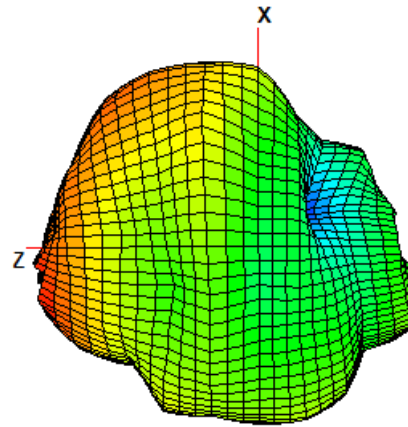

Case 2

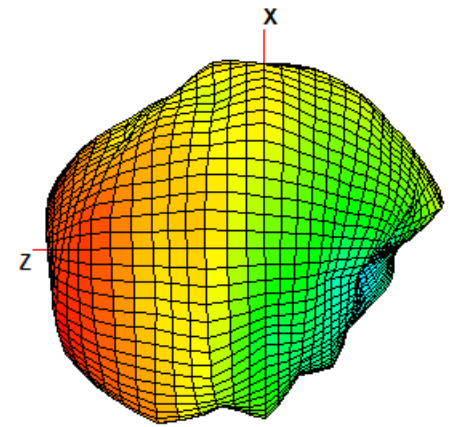

Case 3

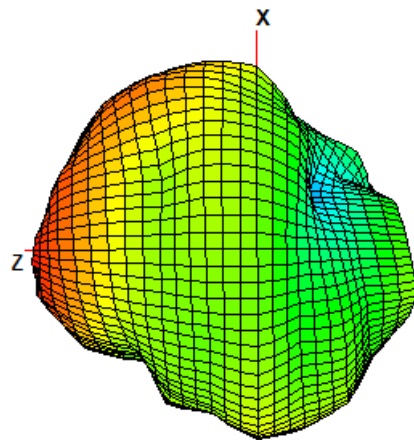

Case 4

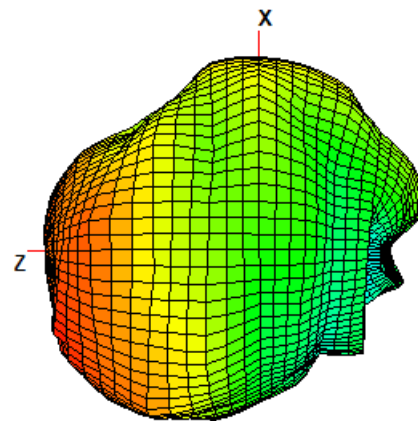

Case 5

Ant 2 @ 5G_YZ-Plane (View 1)

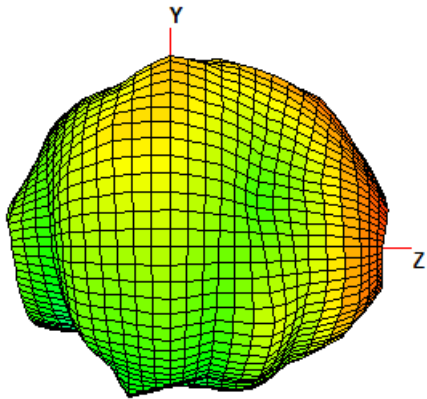
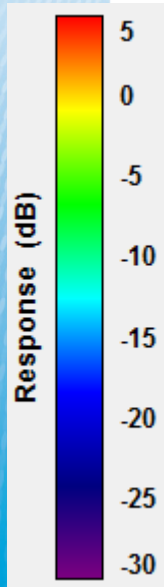

Case 1

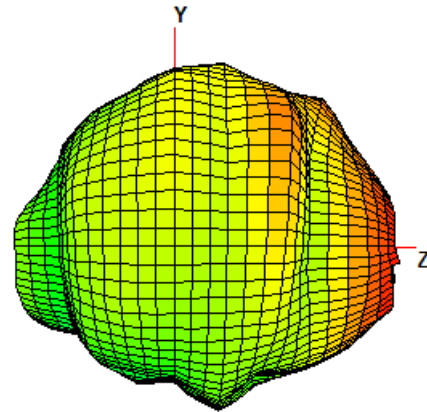

Case 2

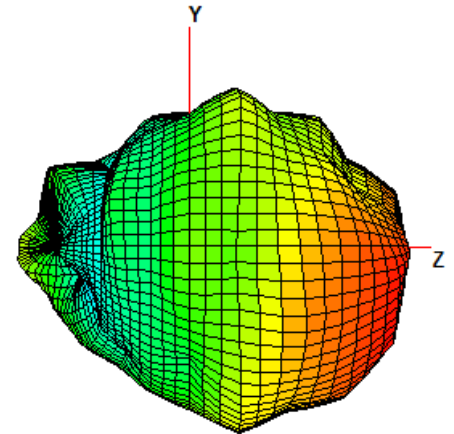

Case 3

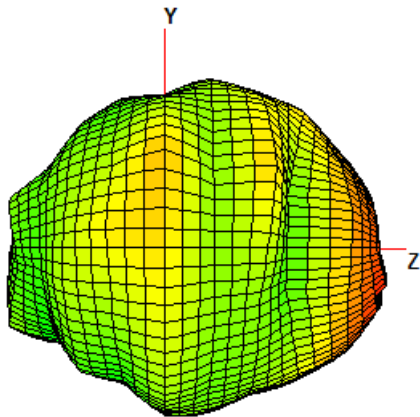

Case 4

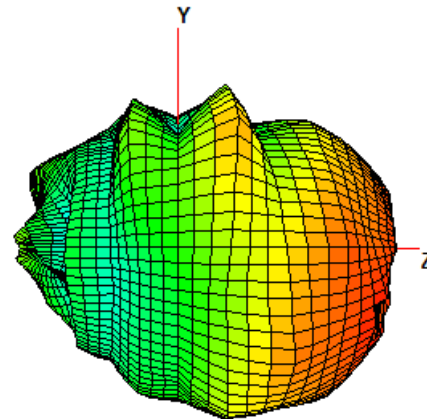

Case 5

Ant 2 @ 5G_YZ-Plane (View 2)

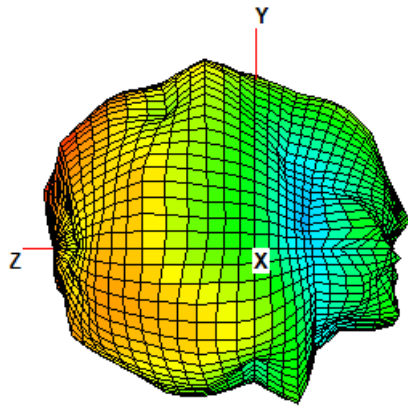
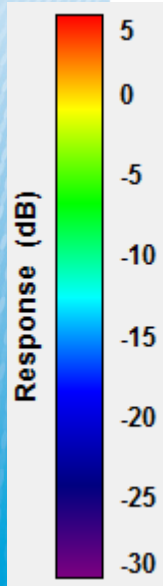

Case 1

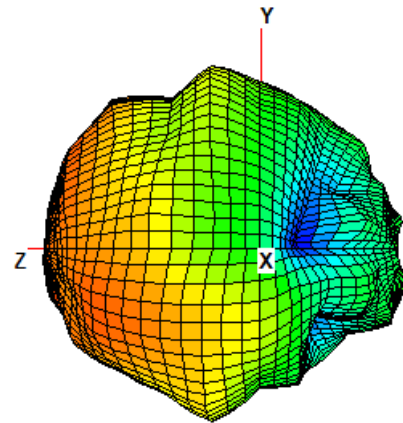

Case 2

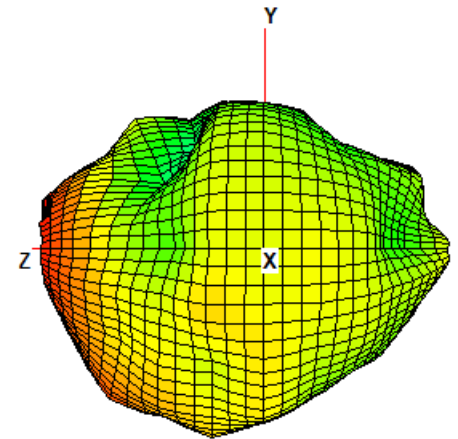

Case 3

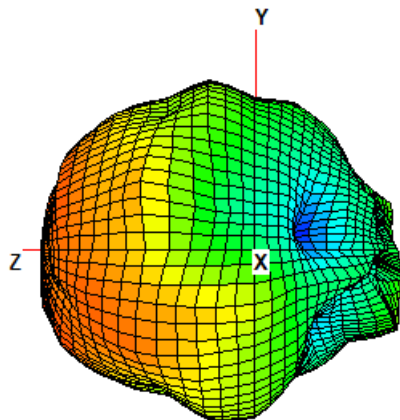

Case 4

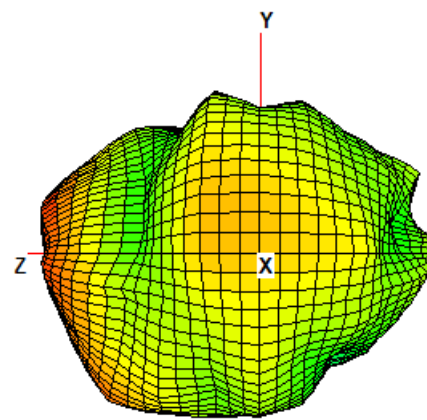

Case 5

Combined Radiation Pattern @ 2.4G_XY-Plane

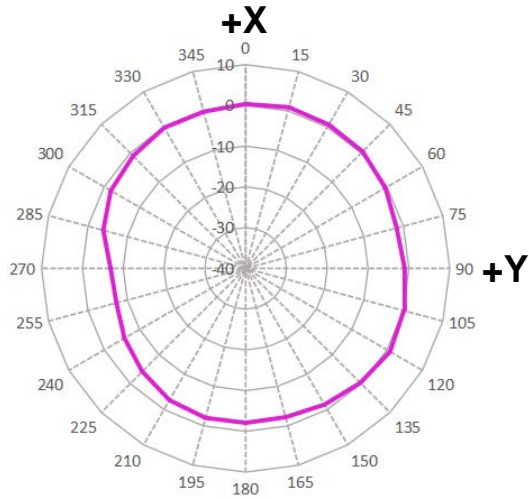

Case 1

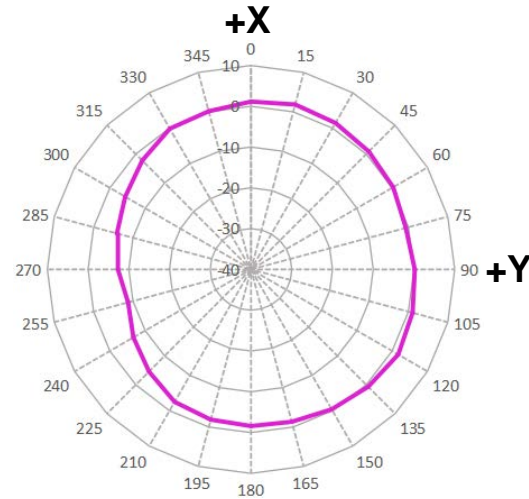

Case 2

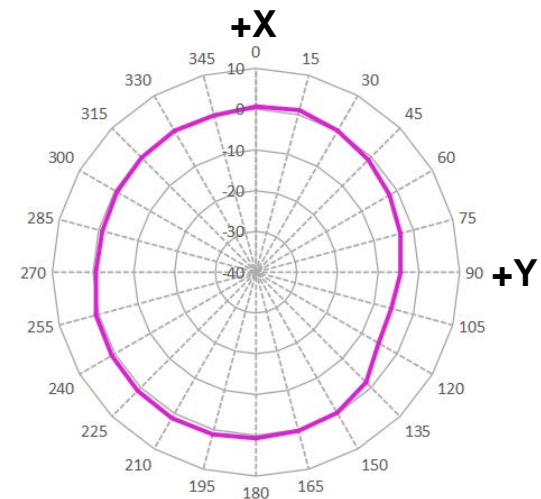

Case 3

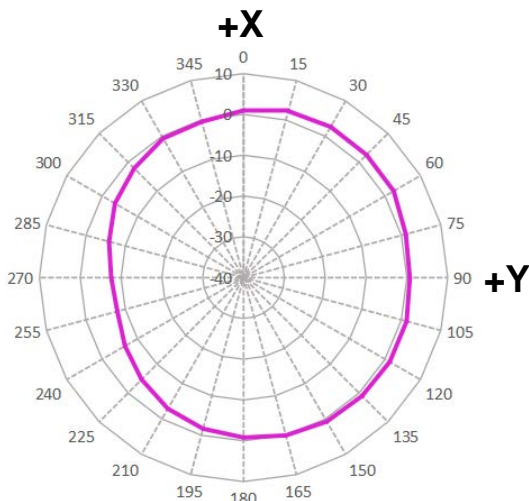

Case 4

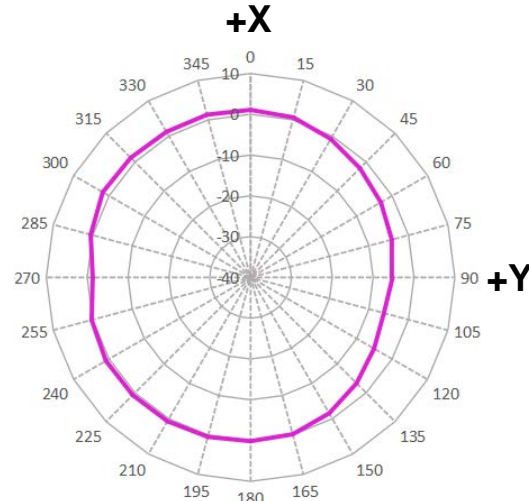

Case 5

Combined Radiation Pattern @ 2.4G_XZ-Plane

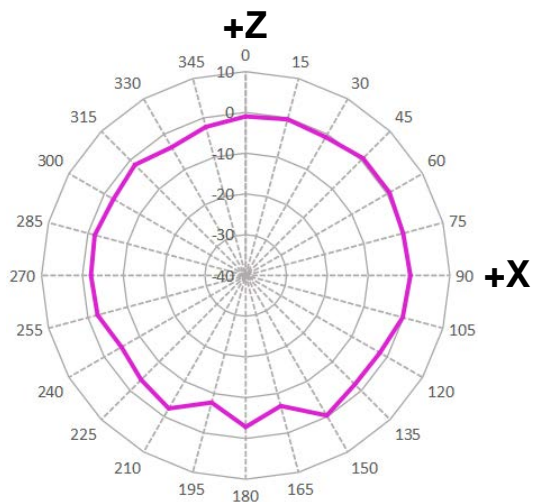

Case 1

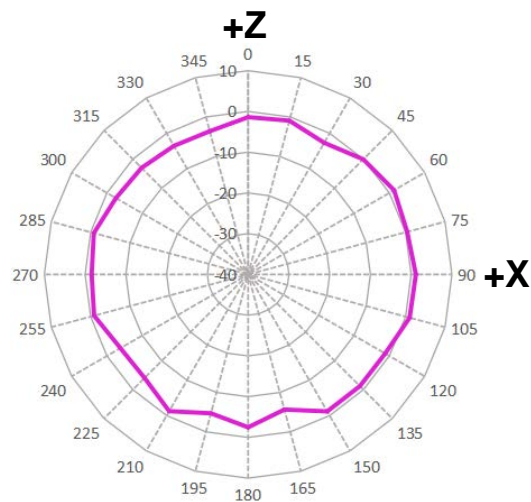

Case 2

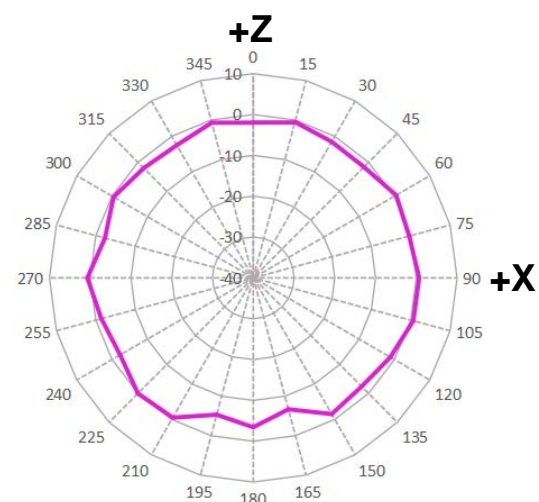

Case 3

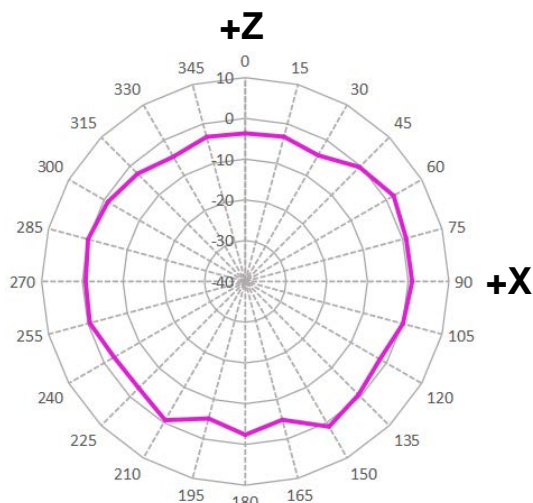

Case 4

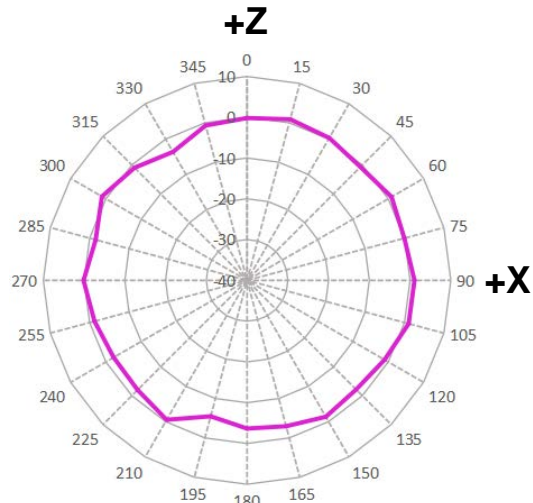

Case 5

Combined Radiation Pattern @ 2.4G_YZ-Plane

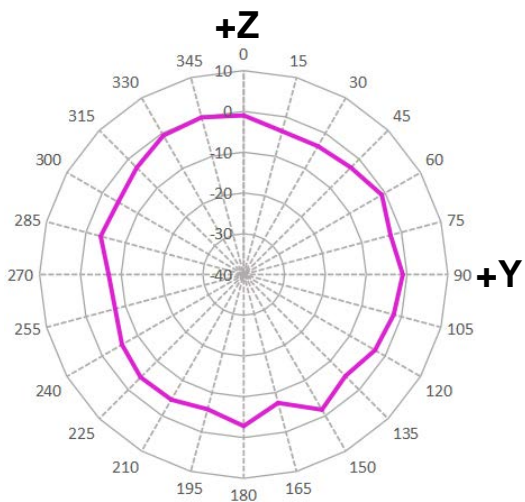

Case 1

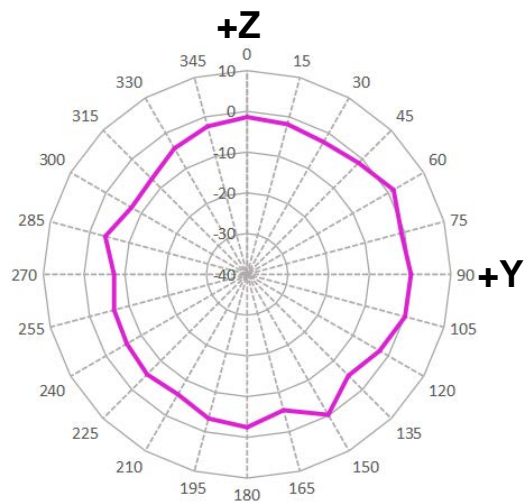

Case 2

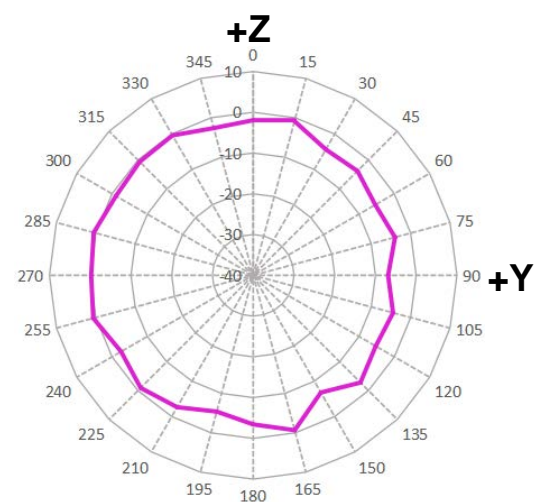

Case 3

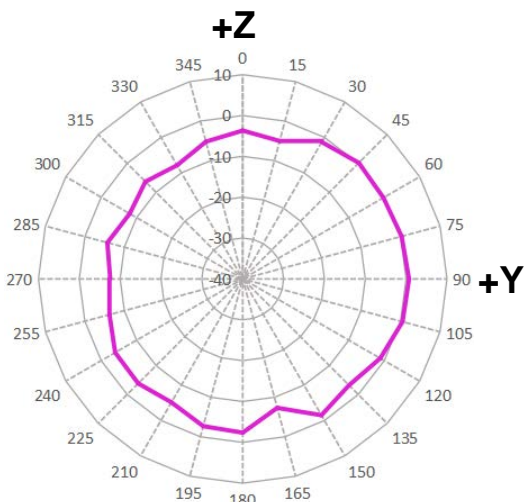

Case 4

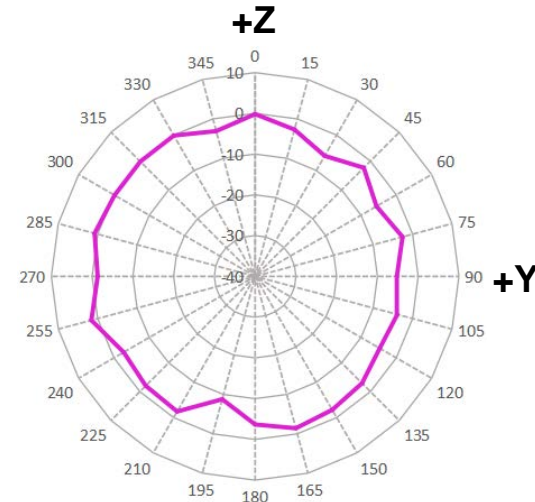

Case 5

Combined Radiation Pattern @ 5G_XY-Plane

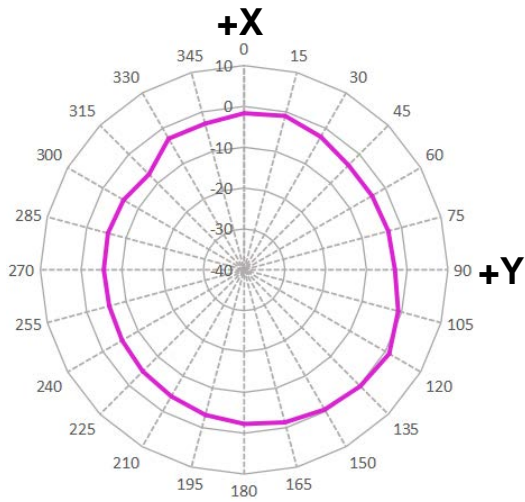

Case 1

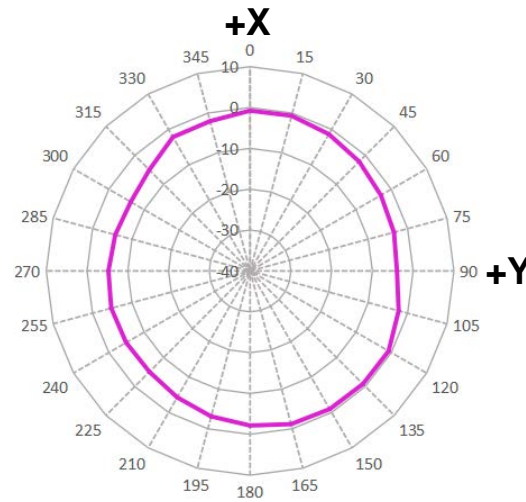

Case 2

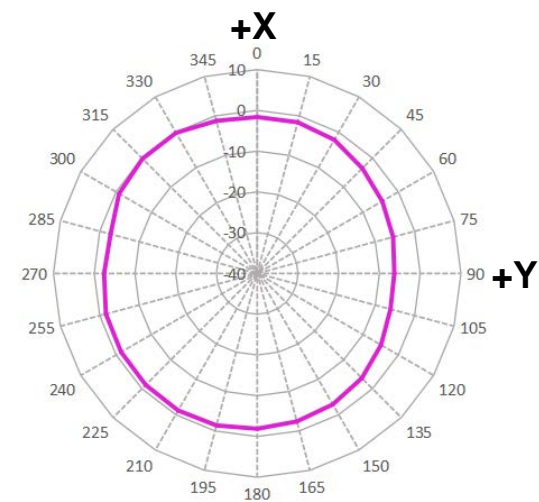

Case 3

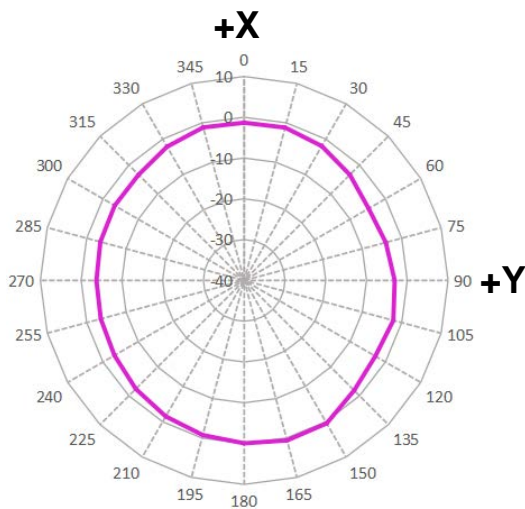

Case 4

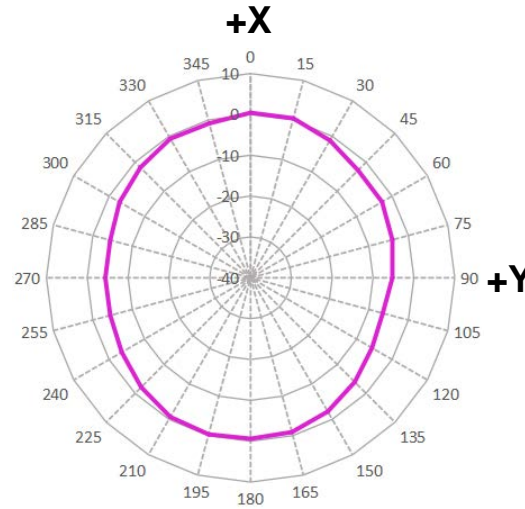

Case 5

Combined Radiation Pattern @ 5G_XZ-Plane

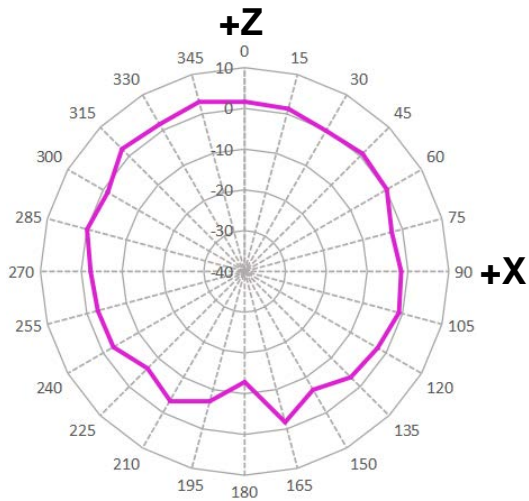

Case 1

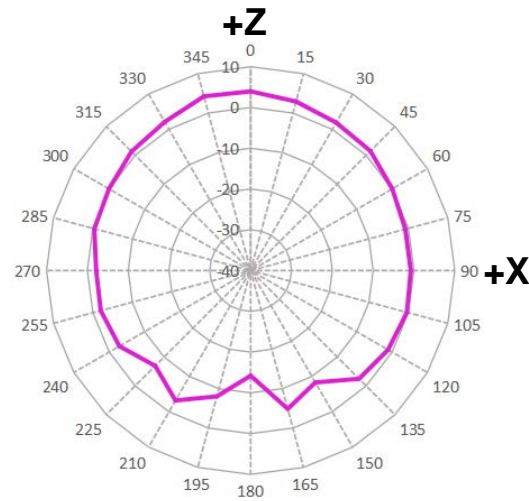

Case 2

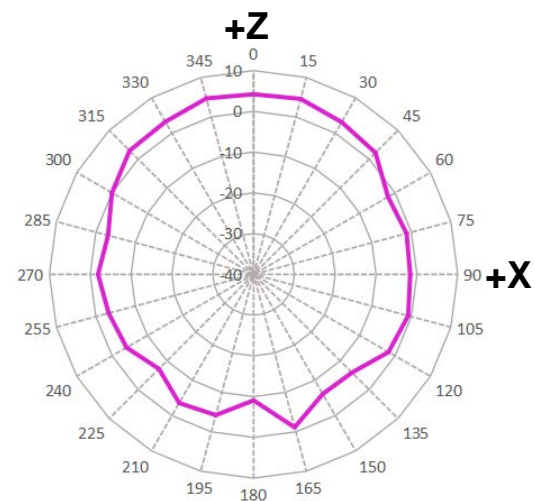

Case 3

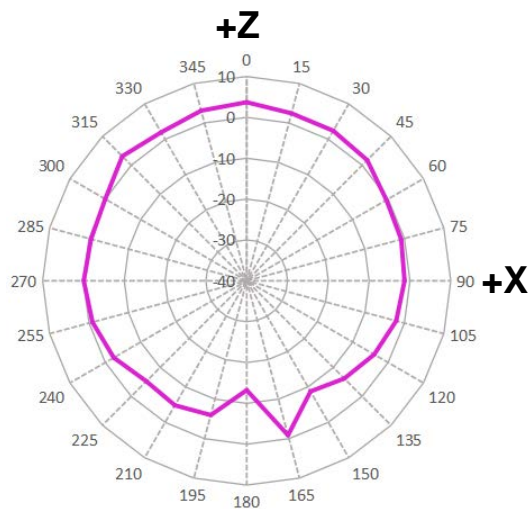

Case 4

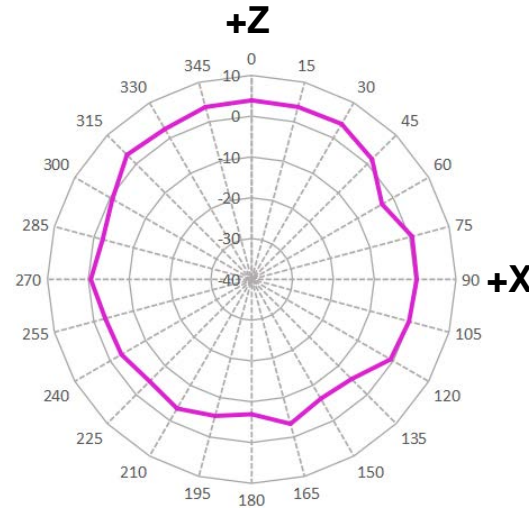

Case 5

Combined Radiation Pattern @ 5G_YZ-Plane

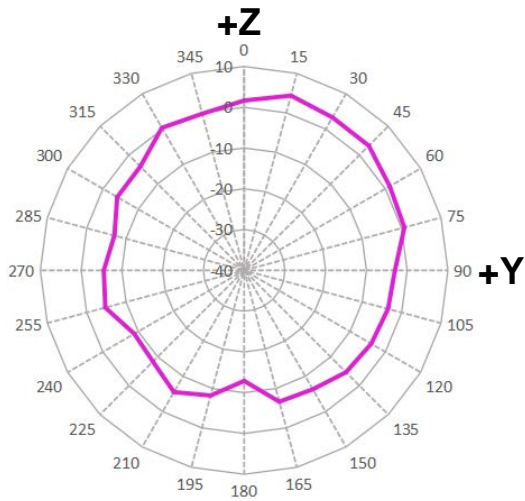

Case 1

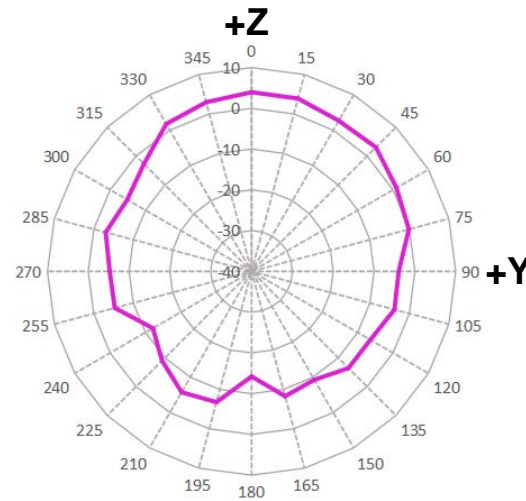

Case 2

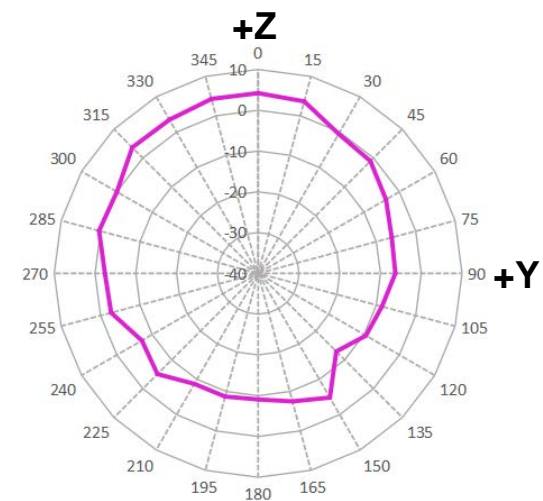

Case 3

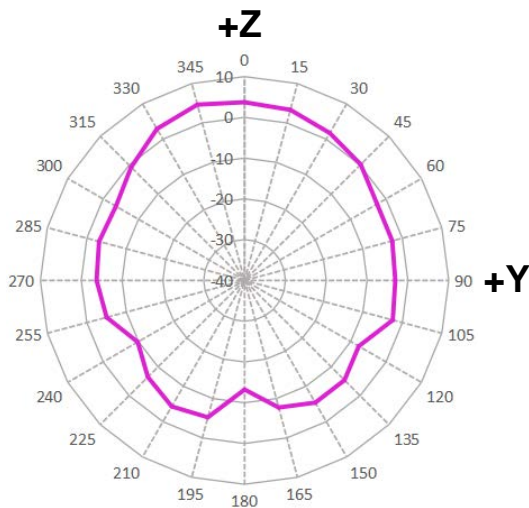

Case 4

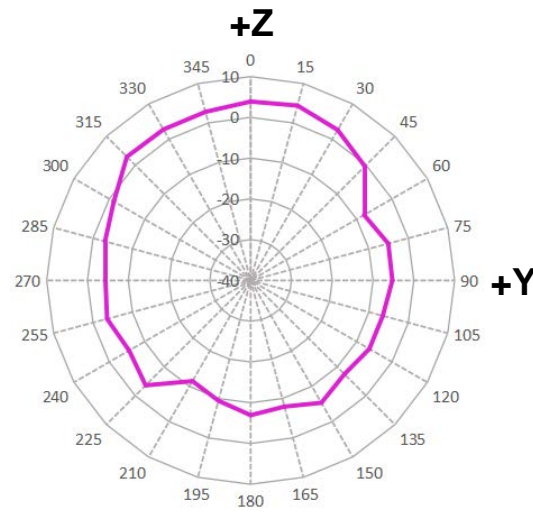

Case 5

SERCOMM

www.sercomm.com