

FCC Test Report

Equipment : IP Wireless Camera
Brand Name : FLIR SECURE
Model No. : FXCx3xxxxx (x= 0-9, A-Z, or blank)
FCC ID : UCZFXC23V
Standard : 47 CFR FCC Part 15.247
Operating Band : 2400 MHz – 2483.5 MHz
Function : Point-to-multipoint; Point-to-point
Applicant : Lorex Technology Inc
250 Royal Crest Court, Markham, Ontario,
L3R 3S1 Canada
Manufacturer : Chicony Electronics (Dong Guan) Co.,Ltd.
San Zhong Guan Li Qu, Qingxi Town,
Dongguan City Guangdong 523651 China

The product sample received on Feb. 06, 2017 and completely tested on Mar. 09, 2017. We, SPORTON, would like to declare that the tested sample has been evaluated in accordance with the procedures given in ANSI C63.10-2013 and shown compliance with the applicable technical standards.

The test results in this report apply exclusively to the tested model / sample. Without written approval of SPORTON INTERNATIONAL INC., the test report shall not be reproduced except in full.

Phoenix Chen
SPORTON INTERNATIONAL INC.





Table of Contents

- 1 GENERAL DESCRIPTION5**
- 1.1 Information.....5
- 1.2 Testing Applied Standards6
- 1.3 Testing Location Information7
- 1.4 Measurement Uncertainty7
- 2 TEST CONFIGURATION OF EUT.....8**
- 2.1 Test Condition8
- 2.2 Test Channel Mode8
- 2.3 The Worst Case Measurement Configuration.....9
- 2.4 Accessories10
- 2.5 Support Equipment.....10
- 2.6 Test Setup Diagram11
- 3 TRANSMITTER TEST RESULT12**
- 3.1 AC Power-line Conducted Emissions12
- 3.2 DTS Bandwidth.....13
- 3.3 Maximum Conducted Output Power14
- 3.4 Power Spectral Density16
- 3.5 Emissions in Non-restricted Frequency Bands17
- 3.6 Emissions in Restricted Frequency Bands.....18
- 4 TEST EQUIPMENT AND CALIBRATION DATA21**

APPENDIX A. TEST RESULTS OF AC POWER-LINE CONDUCTED EMISSIONS

APPENDIX B. TEST RESULTS OF DTS BANDWIDTH

APPENDIX C. TEST RESULTS OF MAXIMUM CONDUCTED OUTPUT POWER

APPENDIX D. TEST RESULTS OF POWER SPECTRAL DENSITY

APPENDIX E. TEST RESULTS OF EMISSIONS IN NON-RESTRICTED FREQUENCY BANDS

APPENDIX F. TEST RESULTS OF EMISSIONS IN RESTRICTED FREQUENCY BANDS

APPENDIX H. TEST PHOTOS

PHOTOGRAPHS OF EUT V01



Summary of Test Result

Conformance Test Specifications				
Report Clause	Ref. Std. Clause	Description	Limit	Result
1.1.2	15.203	Antenna Requirement	FCC 15.203	Complied
3.1	15.207	AC Power-line Conducted Emissions	FCC 15.207	Complied
3.2	15.247(a)	DTS Bandwidth	≥500kHz	Complied
3.3	15.247(b)	Maximum Conducted Output Power	Power [dBm]:30	Complied
3.4	15.247(e)	Power Spectral Density	PSD [dBm/3kHz]:8	Complied
3.5	15.247(d)	Emissions in Non-restricted Frequency Bands	Non-Restricted Bands: > 20 dBc	Complied
3.6	15.247(d)	Emissions in Restricted Frequency Bands	Restricted Bands: FCC 15.209	Complied

Revision History

Report No.	Version	Description	Issued Date
FR671802-01AC	Rev. 01	Initial issue of report	May 03, 2017
FR671802-01AC	Rev. 02	Revise typo	May 08, 2017

1 General Description

1.1 Information

1.1.1 RF General Information

Frequency Range (MHz)	IEEE Std. 802.11	Ch. Frequency (MHz)	Channel Number
2400-2483.5	b, g	2412-2462	1-11 [11]

Band	Mode	BWch (MHz)	Nant
2.4-2.4835GHz	802.11b	20	1TX
2.4-2.4835GHz	802.11g	20	1TX

Note:

- ♦ 11b mode uses a combination of DSSS-DBPSK, DQPSK, CCK modulation.
- ♦ 11g use a combination of OFDM-BPSK, QPSK, 16QAM, 64QAM modulation.
- ♦ BWch is the nominal channel bandwidth.

1.1.2 Antenna Information

Ant.	Port	Brand	Antenna Type	Connector	Gain (dBi)
1	1	-	PIFA	Fixed	1.38
2	2	-	PIFA	I-PEX	1.22

Note 1: EUT can match with above antennas for using. Higher gain in each type of antenna was used to perform the worst configuration and result of that was recorded as the final test result.

Note 2: IEEE 802.11b/g only includes 1TX and Port1 for emission.

1.1.3 EUT Information

Identify EUT	
Presentation of Equipment	<input checked="" type="checkbox"/> Production ; <input type="checkbox"/> Pre-Production ; <input type="checkbox"/> Prototype
Operational Condition	
EUT Power Type	From AC Adapter
Beamforming Function	<input type="checkbox"/> With beamforming <input checked="" type="checkbox"/> Without beamforming
Type of EUT	
<input checked="" type="checkbox"/>	Stand-alone
<input type="checkbox"/>	Combined (EUT where the radio part is fully integrated within another device)
	Combined Equipment - Brand Name / Model No.: ...
<input type="checkbox"/>	Plug-in radio (EUT intended for a variety of host systems)
	Host System - Brand Name / Model No.: ...
<input type="checkbox"/>	Other:



1.1.4 Mode Test Duty Cycle

Mode	DC	DCF(dB)	T(s)	VBW(Hz) ≥ 1/T
802.11b	0.99	0.044	n/a (DC>=0.98)	n/a (DC>=0.98)
802.11g	0.92	0.362	1.421m	1k

1.1.5 Table for Existing Change

This product is an extension of original one reported under Sporton project number: FR671802AC

Below is the table for the change of the product with respect to the original one.

Modifications	Performance Checking
Antenna 1 was modified	All test items
Antenna 2 was Added	NA

1.2 Testing Applied Standards

According to the specifications of the manufacturer, the EUT must comply with the requirements of the following standards:

- ♦ 47 CFR FCC Part 15
- ♦ ANSI C63.10-2013
- ♦ KDB 558074 D01 v03r05

1.3 Testing Location Information

Testing Location		
<input checked="" type="checkbox"/>	HWA YA	ADD : No. 52, Hwa Ya 1st Rd., Kwei-Shan District, Tao Yuan City, Taiwan, R.O.C. TEL : 886-3-327-3456 FAX : 886-3-327-0973
Test site Designation No. 553509 with FCC.		
<input type="checkbox"/>	JHUBEI	ADD : No.8, Lane 724, Bo-ai St., Jhubei City, HsinChu County 302, Taiwan, R.O.C. TEL : 886-3-656-9065 FAX : 886-3-656-9085
Test site Designation No. TW0006 with FCC.		

Test Condition	Test Site No.	Test Engineer	Test Environment	Test Date
RF Conducted	TH01-HY	Ryan	22.5°C / 64%	17/Feb/2017
Radiated	03CH02-HY	Lynus	23.5°C / 65%	09/Mar/2017
AC Conduction	CO04-HY	Bear	22.7°C / 56%	09/Mar/2017

1.4 Measurement Uncertainty

ISO/IEC 17025 requires that an estimate of the measurement uncertainties associated with the emissions test results be included in the report. The measurement uncertainties given below are based on a 95% confidence level (based on a coverage factor (k=2))

Test Items	Uncertainty	Remark
Conducted Emission (150kHz ~ 30MHz)	3.6 dB	Confidence levels of 95%
Radiated Emission (30MHz ~ 1,000MHz)	2.1 dB	Confidence levels of 95%
Radiated Emission (1GHz ~ 18GHz)	2.6 dB	Confidence levels of 95%
Radiated Emission (18GHz ~ 40GHz)	2.9 dB	Confidence levels of 95%
Conducted Emission	1.3 dB	Confidence levels of 95%



2 Test Configuration of EUT

2.1 Test Condition

RF Conducted	Abbreviation	Remark
TnomVnom	Tnom	20°C
-	Vnom	120V

2.2 Test Channel Mode



Test Software	Putty
---------------	-------

Mode	Power Setting
802.11b_(1Mbps)_1TX	-
2412MHz	20
2437MHz	20
2462MHz	20
802.11g_(6Mbps)_1TX	-
2412MHz	18
2437MHz	20
2462MHz	18

2.3 The Worst Case Measurement Configuration

The Worst Case Mode for Following Conformance Tests	
Tests Item	AC power-line conducted emissions
Condition	AC power-line conducted measurement for line and neutral
Operating Mode	CTX
1	Adapter mode

The Worst Case Mode for Following Conformance Tests	
Tests Item	DTS Bandwidth Maximum Conducted Output Power Power Spectral Density Emissions in Non-restricted Frequency Bands
Test Condition	Conducted measurement at transmit chains

The Worst Case Mode for Following Conformance Tests		
Tests Item	Emissions in Restricted Frequency Bands	
Test Condition	Radiated measurement If EUT consist of multiple antenna assembly (multiple antenna are used in EUT regardless of spatial multiplexing MIMO configuration), the radiated test should be performed with highest antenna gain of each antenna type.	
Operating Mode < 1GHz	CTX	
1	Adapter mode	
Operating Mode > 1GHz	CTX	
Orthogonal Planes of EUT	Y Plane	Z Plane
		
Worst Planes of EUT	V	



2.4 Accessories

Accessories				
AC Adapter	Brand Name	Sunny	Model Name	SYS1561-1212
	Power Rating	I/P: 100 – 240 Vac, 1.0 A, O/P: 12 Vdc, 1 A		
	Power Cord	2.99 meter, non-shielded cable, with w/o ferrite core		

2.5 Support Equipment

Support Equipment – RF Conducted				
No.	Equipment	Brand Name	Model Name	FCC ID
1	Notebook	DELL	E5530	DOC
2	Adapter for Notebook	DELL	HA65NM130	DOC
3	Fixture	-	-	-

Note: Support equipment No.3 was provided by customer.

Support Equipment – Radiated Emission				
No.	Equipment	Brand Name	Model Name	FCC ID
1	-	-	-	-

Support Equipment – AC Conduction				
No.	Equipment	Brand Name	Model Name	FCC ID
1	-	-	-	-

2.6 Test Setup Diagram

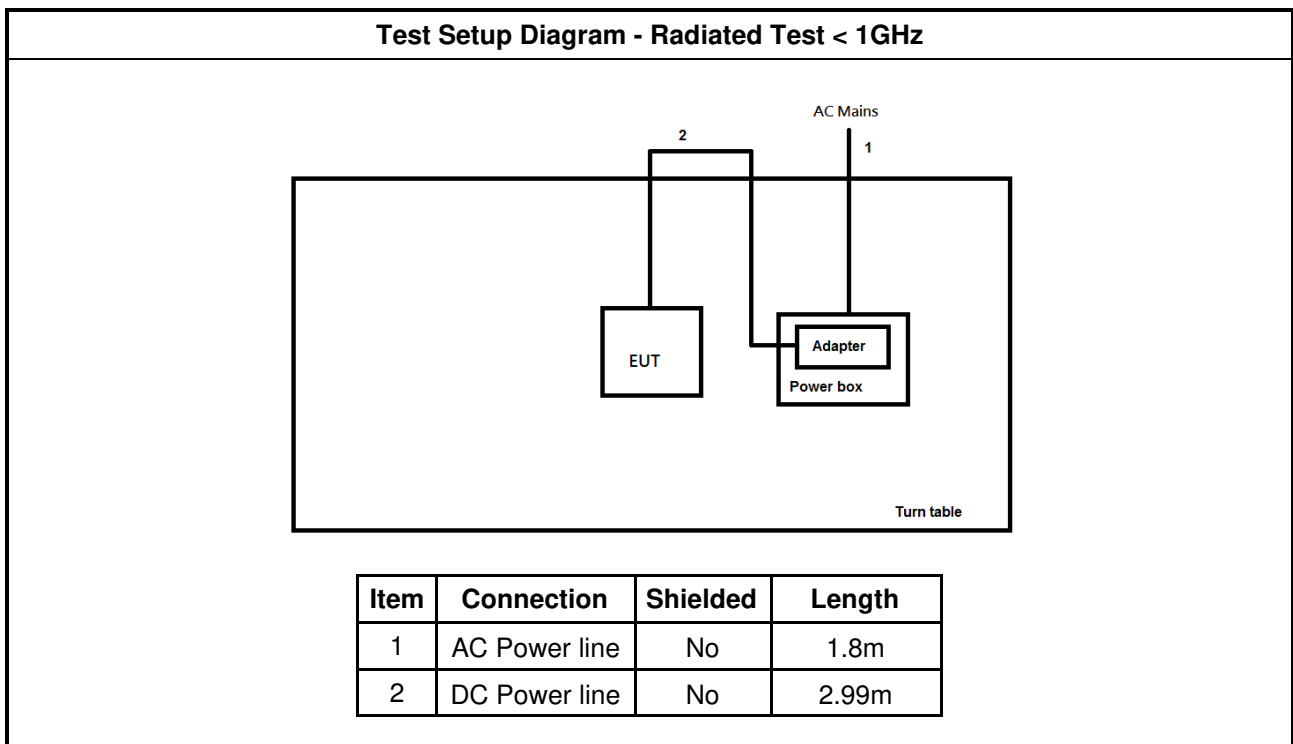
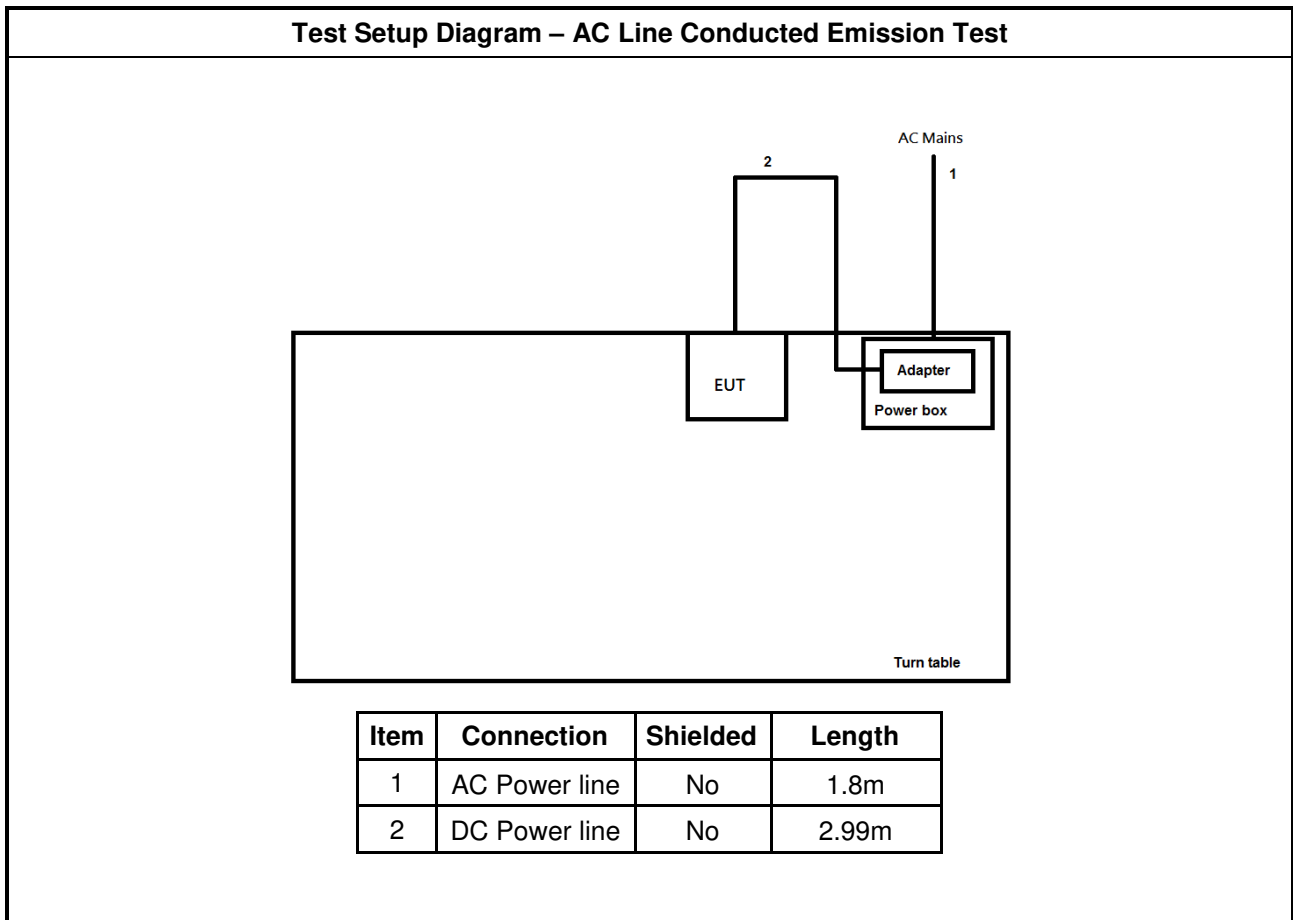

3 Transmitter Test Result

3.1 AC Power-line Conducted Emissions

3.1.1 AC Power-line Conducted Emissions Limit

AC Power-line Conducted Emissions Limit		
Frequency Emission (MHz)	Quasi-Peak	Average
0.15-0.5	66 - 56 *	56 - 46 *
0.5-5	56	46
5-30	60	50

Note 1: * Decreases with the logarithm of the frequency.

3.1.2 Measuring Instruments

Refer a test equipment and calibration data table in this test report.

3.1.3 Test Procedures

Test Method
<input checked="" type="checkbox"/> Refer as ANSI C63.10-2013, clause 6.2 for AC power-line conducted emissions.

3.1.4 Test Setup

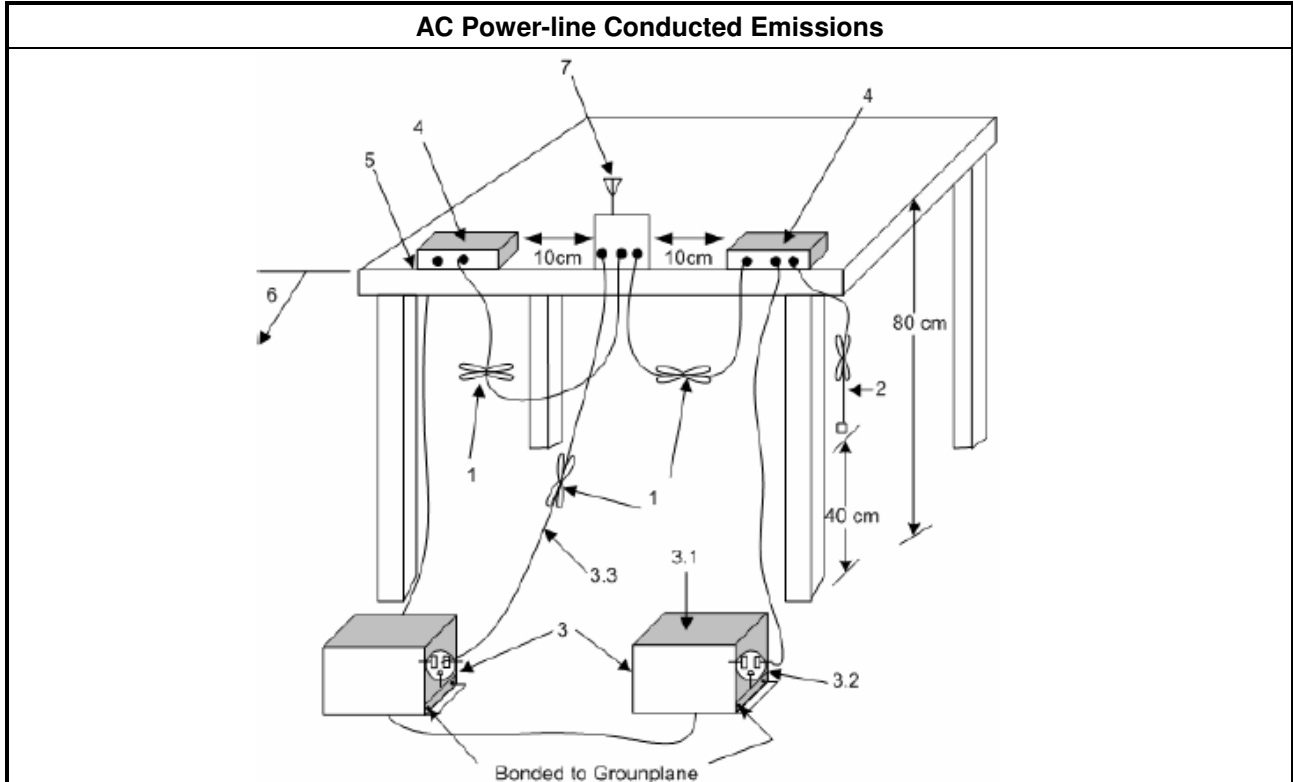

3.1.5 Test Result of AC Power-line Conducted Emissions

Refer as Appendix A

3.2 DTS Bandwidth

3.2.1 6dB Bandwidth Limit

6dB Bandwidth Limit
Systems using digital modulation techniques:
<ul style="list-style-type: none"> ▪ 6 dB bandwidth \geq 500 kHz.

3.2.2 Measuring Instruments

Refer a test equipment and calibration data table in this test report.

3.2.3 Test Procedures

Test Method
<ul style="list-style-type: none"> ▪ For the emission bandwidth shall be measured using one of the options below:
<input checked="" type="checkbox"/> Refer as KDB 558074, clause 8.1 Option 1 for 6 dB bandwidth measurement.
<input type="checkbox"/> Refer as KDB 558074, clause 8.2 Option 2 for 6 dB bandwidth measurement.
<input type="checkbox"/> Refer as ANSI C63.10, clause 6.9.3 for occupied bandwidth testing.

3.2.4 Test Setup

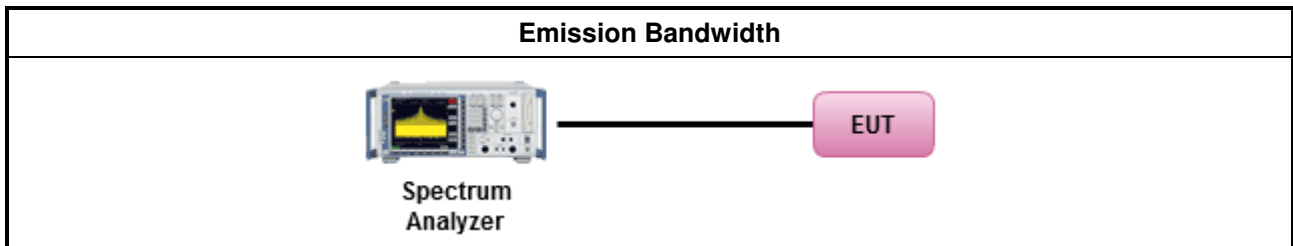

3.2.5 Test Result of Emission Bandwidth

Refer as Appendix B

3.3 Maximum Conducted Output Power

3.3.1 Maximum Conducted Output Power Limit

Maximum Conducted Output Power Limit	
	<ul style="list-style-type: none"> ▪ If $G_{TX} \leq 6$ dBi, then $P_{Out} \leq 30$ dBm (1 W)
	<ul style="list-style-type: none"> ▪ Point-to-multipoint systems (P2M): If $G_{TX} > 6$ dBi, then $P_{Out} = 30 - (G_{TX} - 6)$ dBm
	<ul style="list-style-type: none"> ▪ Point-to-point systems (P2P): If $G_{TX} > 6$ dBi, then $P_{Out} = 30 - (G_{TX} - 6)/3$ dBm
	<ul style="list-style-type: none"> ▪ Smart antenna system (SAS):
	<ul style="list-style-type: none"> - Single beam: If $G_{TX} > 6$ dBi, then $P_{Out} = 30 - (G_{TX} - 6)/3$ dBm
	<ul style="list-style-type: none"> - Overlap beam: If $G_{TX} > 6$ dBi, then $P_{Out} = 30 - (G_{TX} - 6)/3$ dBm
	<ul style="list-style-type: none"> - Aggregate power on all beams: If $G_{TX} > 6$ dBi, then $P_{Out} = 30 - (G_{TX} - 6)/3 + 8$ dBm
e.i.r.p. Power Limit:	
	<ul style="list-style-type: none"> ▪ 2400-2483.5 MHz Band
	<ul style="list-style-type: none"> ▪ Point-to-multipoint systems (P2M): $P_{eirp} \leq 36$ dBm (4 W)
	<ul style="list-style-type: none"> ▪ Point-to-point systems (P2P): $P_{eirp} \leq \text{MAX}(36, [P_{Out} + G_{TX}])$ dBm
	<ul style="list-style-type: none"> ▪ Smart antenna system (SAS)
	<ul style="list-style-type: none"> - Single beam: $P_{eirp} \leq \text{MAX}(36, P_{Out} + G_{TX})$ dBm
	<ul style="list-style-type: none"> - Overlap beam: $P_{eirp} \leq \text{MAX}(36, P_{Out} + G_{TX})$ dBm
	<ul style="list-style-type: none"> - Aggregate power on all beams: $P_{eirp} \leq \text{MAX}(36, [P_{Out} + G_{TX} + 8])$ dBm
<p>P_{Out} = maximum peak conducted output power or maximum conducted output power in dBm, G_{TX} = the maximum transmitting antenna directional gain in dBi.</p>	

3.3.2 Measuring Instruments

Refer a test equipment and calibration data table in this test report.

3.3.3 Test Procedures

Test Method	
<ul style="list-style-type: none"> ▪ Maximum Peak Conducted Output Power 	
<input type="checkbox"/>	Refer as KDB 558074, clause 9.1.1 Option 1 (RBW ≥ EBW method).
<input checked="" type="checkbox"/>	Refer as KDB 558074, clause 9.1.2 Option 2 (peak power meter for VBW ≥ DTS BW)
<ul style="list-style-type: none"> ▪ Maximum Average Conducted Output Power 	
Duty cycle ≥ 98%	
<input type="checkbox"/>	Refer as KDB 558074, clause 9.2.2.4 Method AVGSA-2 (spectral trace averaging).
Duty cycle < 98%	
<input type="checkbox"/>	Refer as KDB 558074, clause 9.2.2.5 Method AVGSA-2 Alt. (slow sweep speed)
RF power meter and average over on/off periods with duty factor or gated trigger	
<input checked="" type="checkbox"/>	Refer as KDB 558074, clause 9.2.3.1 Method AVGPM (using an RF average power meter).
<ul style="list-style-type: none"> ▪ For conducted measurement. 	
<ul style="list-style-type: none"> ▪ If the EUT supports multiple transmit chains using options given below: Refer as KDB 662911, In-band power measurements. Using the measure-and-sum approach, measured all transmit ports individually. Sum the power (in linear power units e.g., mW) of all ports for each individual sample and save them. 	
<ul style="list-style-type: none"> ▪ If multiple transmit chains, EIRP calculation could be following as methods: $P_{total} = P_1 + P_2 + \dots + P_n$ (calculated in linear unit [mW] and transfer to log unit [dBm]) $EIRP_{total} = P_{total} + DG$ 	

3.3.4 Test Setup

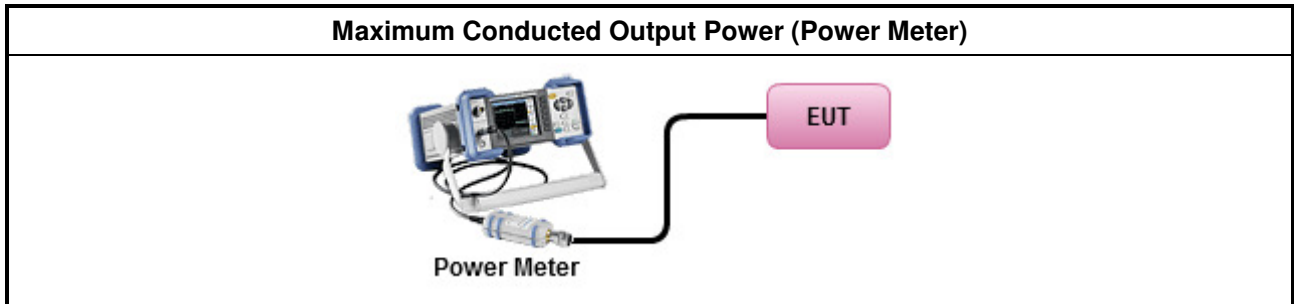

3.3.5 Test Result of Maximum Conducted Output Power

Refer as Appendix C

3.4 Power Spectral Density

3.4.1 Power Spectral Density Limit

Power Spectral Density Limit
<ul style="list-style-type: none"> Power Spectral Density (PSD) \leq 8 dBm/3kHz

3.4.2 Measuring Instruments

Refer a test equipment and calibration data table in this test report.

3.4.3 Test Procedures

Test Method	
<ul style="list-style-type: none"> Peak power spectral density procedures that the same method as used to determine the conducted output power. If maximum peak conducted output power was measured to demonstrate compliance to the output power limit, then the peak PSD procedure below (Method PKPSD) shall be used. If maximum conducted output power was measured to demonstrate compliance to the output power limit, then one of the average PSD procedures shall be used, as applicable based on the following criteria (the peak PSD procedure is also an acceptable option). 	
<input checked="" type="checkbox"/> Refer as KDB 558074, clause 10.2 Method PKPSD (RBW=3-100kHz; Detector=peak).	
<ul style="list-style-type: none"> For conducted measurement. 	
<ul style="list-style-type: none"> If The EUT supports multiple transmit chains using options given below: 	
<input type="checkbox"/>	Measure and sum the spectra across the outputs. Refer as KDB 662911, In-band power spectral density (PSD). Sample all transmit ports simultaneously using a spectrum analyzer for each transmit port. Where the trace bin-by-bin of each transmit port summing can be performed. (i.e., in the first spectral bin of output 1 is summed with that in the first spectral bin of output 2 and that from the first spectral bin of output 3, and so on up to the NTX output to obtain the value for the first frequency bin of the summed spectrum.). Add up the amplitude (power) values for the different transmit chains and use this as the new data trace.

3.4.4 Test Setup

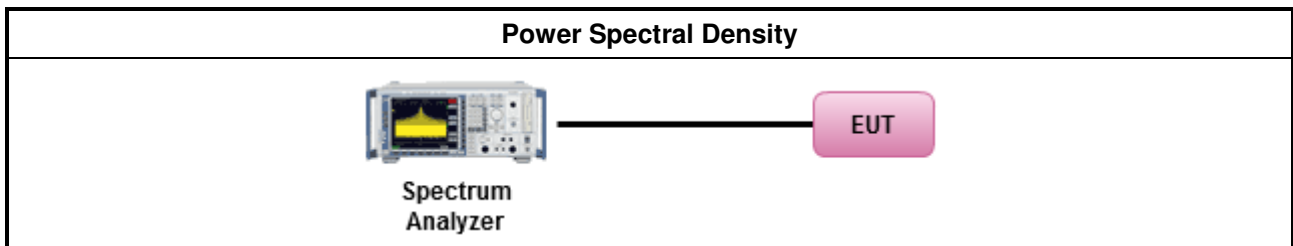

3.4.5 Test Result of Power Spectral Density

Refer as Appendix D

3.5 Emissions in Non-restricted Frequency Bands

3.5.1 Emissions in Non-restricted Frequency Bands Limit

Un-restricted Band Emissions Limit	
RF output power procedure	Limit (dB)
Peak output power procedure	20
Average output power procedure	30

Note 1: If the peak output power procedure is used to measure the fundamental emission power to demonstrate compliance to requirements, then the peak conducted output power measured within any 100 kHz outside the authorized frequency band shall be attenuated by at least 20 dB relative to the maximum measured in-band peak PSD level.

Note 2: If the average output power procedure is used to measure the fundamental emission power to demonstrate compliance to requirements, then the power in any 100 kHz outside of the authorized frequency band shall be attenuated by at least 30 dB relative to the maximum measured in-band average PSD level.

3.5.2 Measuring Instruments

Refer a test equipment and calibration data table in this test report.

3.5.3 Test Procedures

Test Method
<ul style="list-style-type: none"> Refer as KDB 558074, clause 11 for unwanted emissions into non-restricted bands.

3.5.4 Test Setup

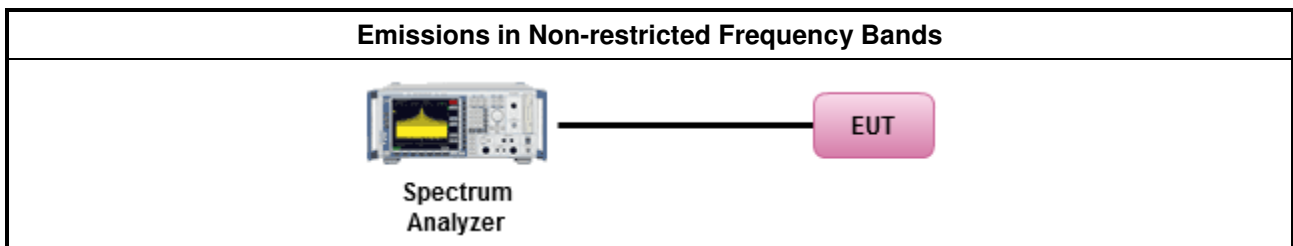

3.5.5 Test Result of Emissions in Non-restricted Frequency Bands

Refer as Appendix E

3.6 Emissions in Restricted Frequency Bands

3.6.1 Emissions in Restricted Frequency Bands Limit

Restricted Band Emissions Limit			
Frequency Range (MHz)	Field Strength (uV/m)	Field Strength (dBuV/m)	Measure Distance (m)
0.009~0.490	2400/F(kHz)	48.5 - 13.8	300
0.490~1.705	24000/F(kHz)	33.8 - 23	30
1.705~30.0	30	29	30
30~88	100	40	3
88~216	150	43.5	3
216~960	200	46	3
Above 960	500	54	3

Note 1: Test distance for frequencies at or above 30 MHz, measurements may be performed at a distance other than the limit distance provided they are not performed in the near field and the emissions to be measured can be detected by the measurement equipment. When performing measurements at a distance other than that specified, the results shall be extrapolated to the specified distance using an extrapolation factor of 20 dB/decade (inverse of linear distance for field-strength measurements, inverse of linear distance-squared for power-density measurements).

Note 2: Test distance for frequencies at below 30 MHz, measurements may be performed at a distance closer than the EUT limit distance; however, an attempt should be made to avoid making measurements in the near field. When performing measurements below 30 MHz at a closer distance than the limit distance, the results shall be extrapolated to the specified distance by either making measurements at a minimum of two or more distances on at least one radial to determine the proper extrapolation factor or by using the square of an inverse linear distance extrapolation factor (40 dB/decade). The test report shall specify the extrapolation method used to determine compliance of the EUT.

3.6.2 Measuring Instruments

Refer a test equipment and calibration data table in this test report.

3.6.3 Test Procedures

Test Method	
<ul style="list-style-type: none"> ▪ The average emission levels shall be measured in [duty cycle \geq 98 or duty factor]. 	
<ul style="list-style-type: none"> ▪ Refer as ANSI C63.10, clause 6.10.3 band-edge testing shall be performed at the lowest frequency channel and highest frequency channel within the allowed operating band. 	
<ul style="list-style-type: none"> ▪ For the transmitter unwanted emissions shall be measured using following options below: 	
<ul style="list-style-type: none"> ▪ Refer as KDB 558074, clause 12 for unwanted emissions into restricted bands. 	
	<ul style="list-style-type: none"> <input checked="" type="checkbox"/> Refer as KDB 558074, clause 12.2.5.3 (ANSI C63.10, clause 4.1.4.2.3), Reduced VBW\geq1/T.
	<ul style="list-style-type: none"> <input checked="" type="checkbox"/> Refer as KDB 558074, clause 12.2.4 measurement procedure peak limit.
<ul style="list-style-type: none"> ▪ For the transmitter band-edge emissions shall be measured using following options below: 	
<ul style="list-style-type: none"> ▪ Refer as KDB 558074 clause 13.1, When the performing peak or average radiated measurements, emissions within 2 MHz of the authorized band edge may be measured using the marker-delta method described below. 	
<ul style="list-style-type: none"> ▪ Refer as KDB 558074, clause 13.2 (ANSI C63.10, clause 6.10.6) for marker-delta method for band-edge measurements. 	
<ul style="list-style-type: none"> ▪ Refer as KDB 558074, clause 13.3 for narrower resolution bandwidth (100kHz) using the band power and summing the spectral levels (i.e., 1 MHz). 	
<ul style="list-style-type: none"> ▪ For conducted and cabinet radiation measurement, refer as KDB 558074, clause 12.2.2. 	
<ul style="list-style-type: none"> ▪ For conducted unwanted emissions into restricted bands (absolute emission limits). Devices with multiple transmit chains using options given below: (1) Measure and sum the spectra across the outputs or (2) Measure and add 10 log(N) dB 	
<ul style="list-style-type: none"> ▪ For KDB 662911 The methodology described here may overestimate array gain, thereby resulting in apparent failures to satisfy the out-of-band limits even if the device is actually compliant. In such cases, compliance may be demonstrated by performing radiated tests around the frequencies at which the apparent failures occurred. 	

3.6.4 Test Setup

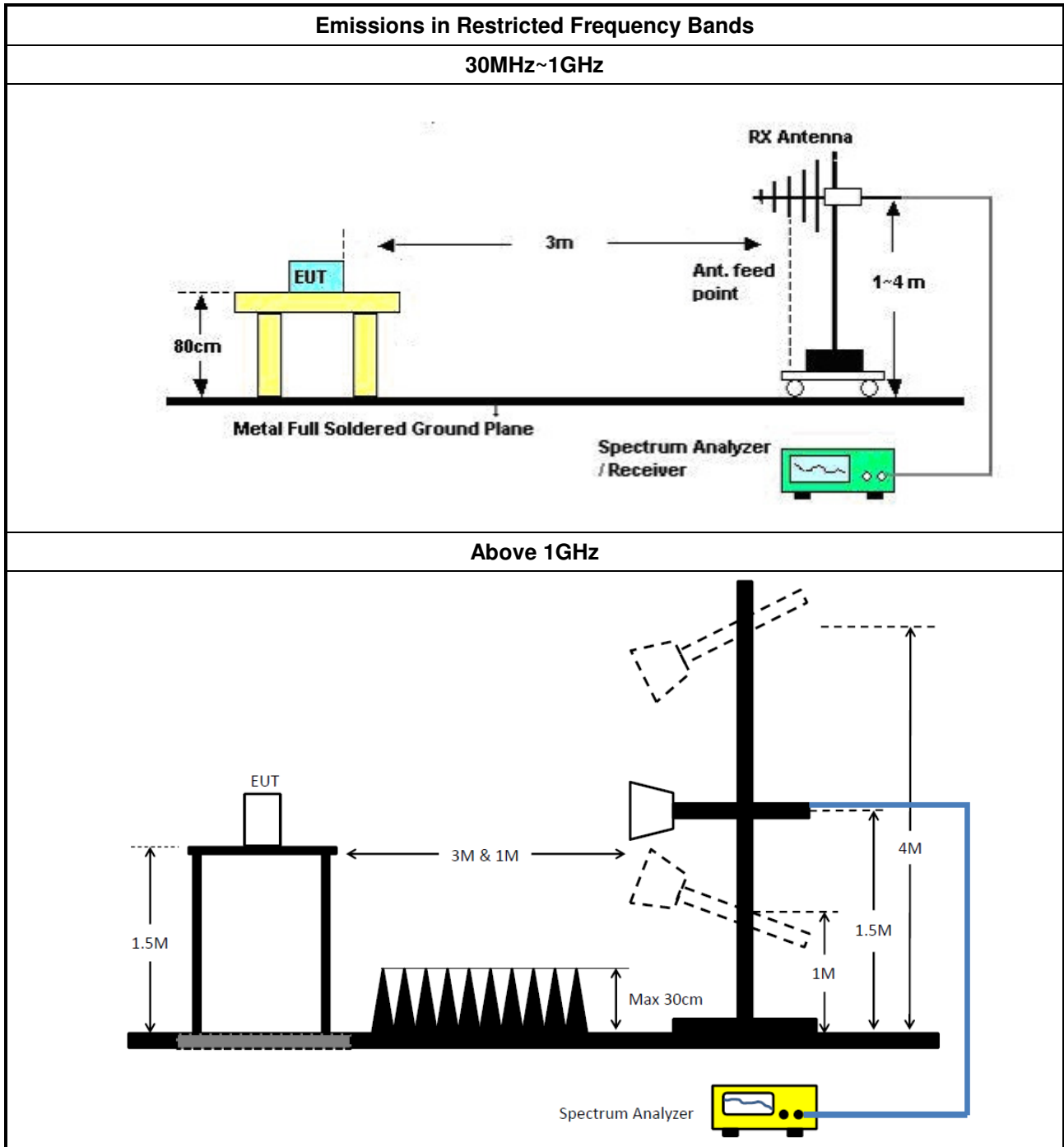

3.6.5 Test Result of Emissions in Restricted Frequency Bands (Below 30MHz)

The amplitude of spurious emissions which are attenuated by more than 20dB below the permissible value has no need to be reported. All amplitude of spurious emissions that are attenuated by more than 20 dB below the permissible value has no need to be reported.

3.6.6 Test Result of Emissions in Restricted Frequency Bands

Refer as Appendix F



4 Test Equipment and Calibration Data

Instrument for AC Conduction

Instrument	Manufacturer	Model No.	Serial No.	Spec.	Calibration Date	Calibration Due Date
EMC Receiver	R&S	ESR3	102051	9KHz ~ 3.6GHz	15/Apr/2016	14/Apr/2017
LISN	R&S	ENV216	101295	9kHz ~ 30MHz	15/Nov/2016	14/Nov/2017
RF Cable-CON	HUBER+SUHNER	RG213/U	07611832020001	9kHz ~ 30MHz	24/Oct/2016	23/Oct/2017

Instrument for Radiated Test

Instrument	Manufacturer	Model No.	Serial No.	Spec.	Calibration Date	Calibration Due Date
Spectrum Analyzer	R&S	FSP40	100593	9KHz~40GHz	26/Oct/2016	25/Oct/2017
3m Semi Anechoic	SIDT FRANKONIA	SAC-3M	03CH02-HY	30MHz~1GHz	03/Jun/2016	02/Jun/2017
3m Semi Anechoic	SIDT FRANKONIA	SAC-3M	03CH02-HY	1GHz~18GHz	12/Dec/2016	11/Dec/2017
Amplifier	Agilent	8447D	2944A11149	100KHz~1.3GHz	01/Jul/2016	30/Jun/2017
Amplifier	Agilent	8449B	3008A02373	1GHz~26.5GHz	02/Sep/2016	01/Sep/2017
Horn Antenna	SCHWARZBECK	BBHA9120D	BBHA9120D 01543	1GHz~18GHz	22/Apr/2016	21/Apr/2017
Horn Antenna	SCHWARZBECK	BBHA9170	BBHA9170339	15GHz~40GHz	10/Mar/2016	09/Mar/2017
Bilog Antenna	SCHAFFNER	CBL6112B	2723	30MHz~1GHz	01/Oct/2016	30/Sep/2017
Loop Antenna	TESEQ	HLA 6120	24155	9KHz~30MHz	16/Mar/2016	15/Mar/2017
RF Cable-high	SUHNER	SUCOFLEX104	MY34918/4	1GHz~40GHz	26/Jan/2017	25/Jan/2018
RF Cable-R03m	Jye Bao	RG142	CB017	9kHz~1GHz	26/Jan/2017	25/Jan/2018

Instrument for Conducted Test

Instrument	Manufacturer	Model No.	Serial No.	Spec.	Calibration Date	Calibration Due Date
Spectrum Analyzer	R&S	FSV 40	101500	9kHz~40GHz	12/May/2016	11/May/ 2017
Power Sensor	Anritsu	MA2411B	1027452	300MHz ~ 40GHz	22/Feb/2016	21/Feb/2017
Power Meter	Anritsu	ML2495A	1124009	300MHz ~ 40GHz	22/Feb/2016	21/Feb/2017
Signal Generator	R&S	SMR40	100116	10MHz ~ 40GHz	21/Jul/2016	20/Jul/2017
RF Cable-0.2m	HUBER+SUHNER	SUCOFLEX_104	MY10709/4	30MHz ~ 26.5GHz	02/Oct/2016	01/Oct/2017
RF Cable-0.2m	HUBER+SUHNER	SUCOFLEX_104	MY10710/4	30MHz ~ 26.5GHz	02/Oct/2016	01/Oct/2017
RF Cable-0.5m	HUBER+SUHNER	SUCOFLEX_104	MY10713/4	30MHz ~ 26.5GHz	02/Oct/2016	01/Oct/2017



AC Power-line Conducted Emissions Result

Operating Mode	1	Power Phase	Neutral
Operating Function	Adapter Mode		

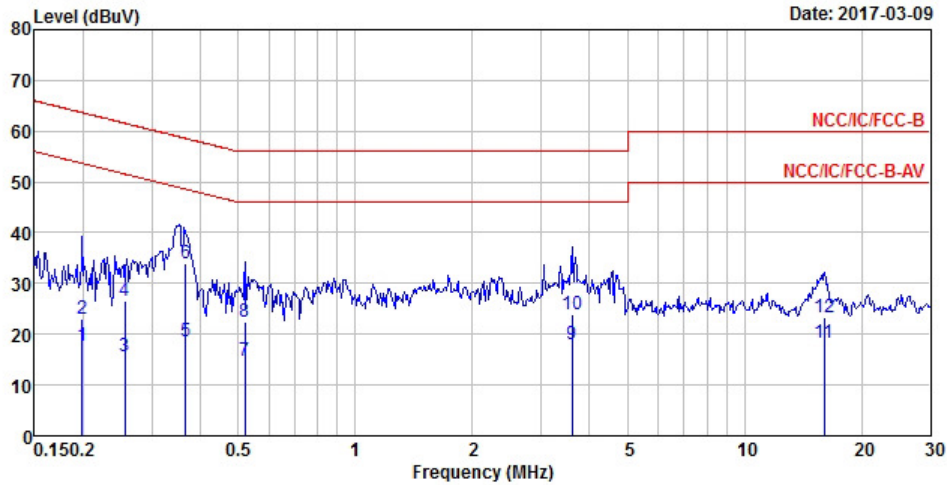

	Freq	Level	Over	Limit	Read	LISN	Cable	
	MHz	dBuV	Limit	Line	Level	Factor	Loss	Remark
			dB	dBuV	dBuV	dB	dB	
1	0.20	17.76	-35.91	53.67	7.79	9.67	0.30	Average
2	0.20	23.09	-40.58	63.67	13.12	9.67	0.30	QP
3	0.26	15.73	-35.84	51.57	5.84	9.66	0.23	Average
4	0.26	26.61	-34.96	61.57	16.72	9.66	0.23	QP
5	0.37	18.65	-29.92	48.57	8.88	9.64	0.13	Average
6 MAX	0.37	34.00	-24.57	58.57	24.23	9.64	0.13	QP
7	0.52	14.87	-31.13	46.00	5.15	9.62	0.10	Average
8	0.52	22.31	-33.69	56.00	12.59	9.62	0.10	QP
9	3.60	18.14	-27.86	46.00	8.31	9.70	0.13	Average
10	3.60	23.81	-32.19	56.00	13.98	9.70	0.13	QP
11	16.05	18.36	-31.64	50.00	8.32	9.84	0.20	Average
12	16.05	23.35	-36.65	60.00	13.31	9.84	0.20	QP

Note 1: ">20dB" means emission levels that exceed the level of 20 dB below the applicable limit.
 Note 2: "N/F" means Nothing Found emissions (No emissions were detected.)



AC Power-line Conducted Emissions Result

Operating Mode	1	Power Phase	Line
Operating Function	Adapter Mode		

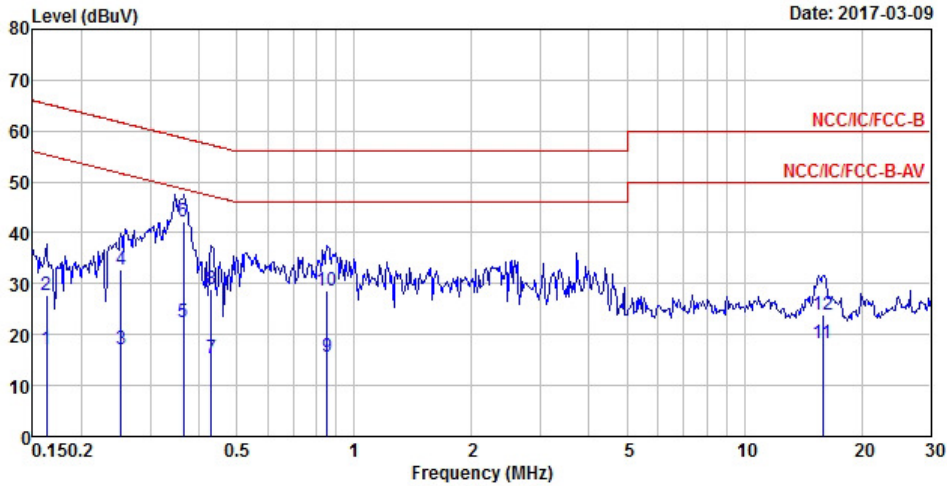

	Freq	Level	Over Limit	Limit Line	Read Level	LISN Factor	Cable Loss	Remark
	MHz	dBuV	dB	dBuV	dBuV	dB	dB	
1	0.16	17.20	-38.14	55.34	7.34	9.62	0.24	Average
2	0.16	27.82	-37.52	65.34	17.96	9.62	0.24	QP
3	0.25	16.98	-34.71	51.69	7.09	9.66	0.23	Average
4	0.25	32.71	-28.98	61.69	22.82	9.66	0.23	QP
5	0.36	22.53	-26.10	48.63	12.76	9.64	0.13	Average
6 MAX	0.36	42.17	-16.46	58.63	32.40	9.64	0.13	QP
7	0.43	15.34	-31.90	47.24	5.61	9.63	0.10	Average
8	0.43	29.02	-28.22	57.24	19.29	9.63	0.10	QP
9	0.85	15.58	-30.42	46.00	5.88	9.60	0.10	Average
10	0.85	28.54	-27.46	56.00	18.84	9.60	0.10	QP
11	15.89	18.32	-31.68	50.00	8.28	9.84	0.20	Average
12	15.89	23.83	-36.17	60.00	13.79	9.84	0.20	QP

Note 1: ">20dB" means emission levels that exceed the level of 20 dB below the applicable limit.
 Note 2: "N/F" means Nothing Found emissions (No emissions were detected.)



Summary

Mode	Max-N dB (Hz)	Max-OBW (Hz)	ITU-Code	Min-N dB (Hz)	Min-OBW (Hz)
802.11b_(1Mbps)_1TX	-	-	-	-	-
2.4-2.4835GHz	8.525M	14.268M	14M3G1D	8.5M	14.143M
802.11g_(6Mbps)_1TX	-	-	-	-	-
2.4-2.4835GHz	15.45M	16.442M	16M4D1D	15M	16.317M

Max-N dB = Maximum 6dB down bandwidth; **Max-OBW** = Maximum 99% occupied bandwidth;
Min-N dB = Minimum 6dB down bandwidth; **Min-OBW** = Minimum 99% occupied bandwidth;

Result

Mode	Result	Limit (Hz)	Port 1-N dB (Hz)	Port 1-OBW (Hz)
802.11b_(1Mbps)_1TX	-	-	-	-
2412MHz	Pass	500k	8.525M	14.168M
2437MHz	Pass	500k	8.5M	14.268M
2462MHz	Pass	500k	8.5M	14.143M
802.11g_(6Mbps)_1TX	-	-	-	-
2412MHz	Pass	500k	15M	16.317M
2437MHz	Pass	500k	15.45M	16.442M
2462MHz	Pass	500k	15.25M	16.317M

Port X-N dB = Port X 6dB down bandwidth; **Port X-OBW** = Port X 99% occupied bandwidth;

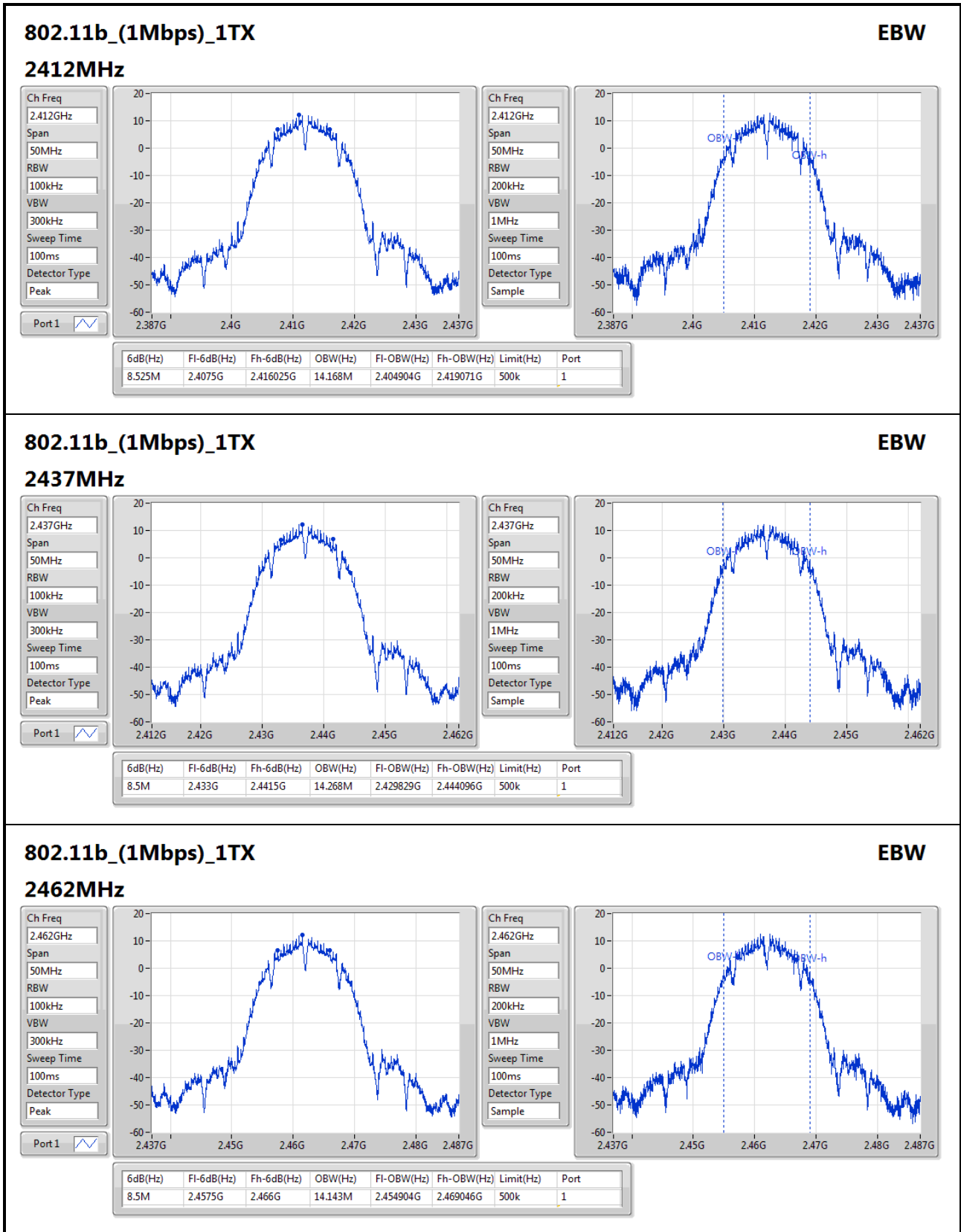

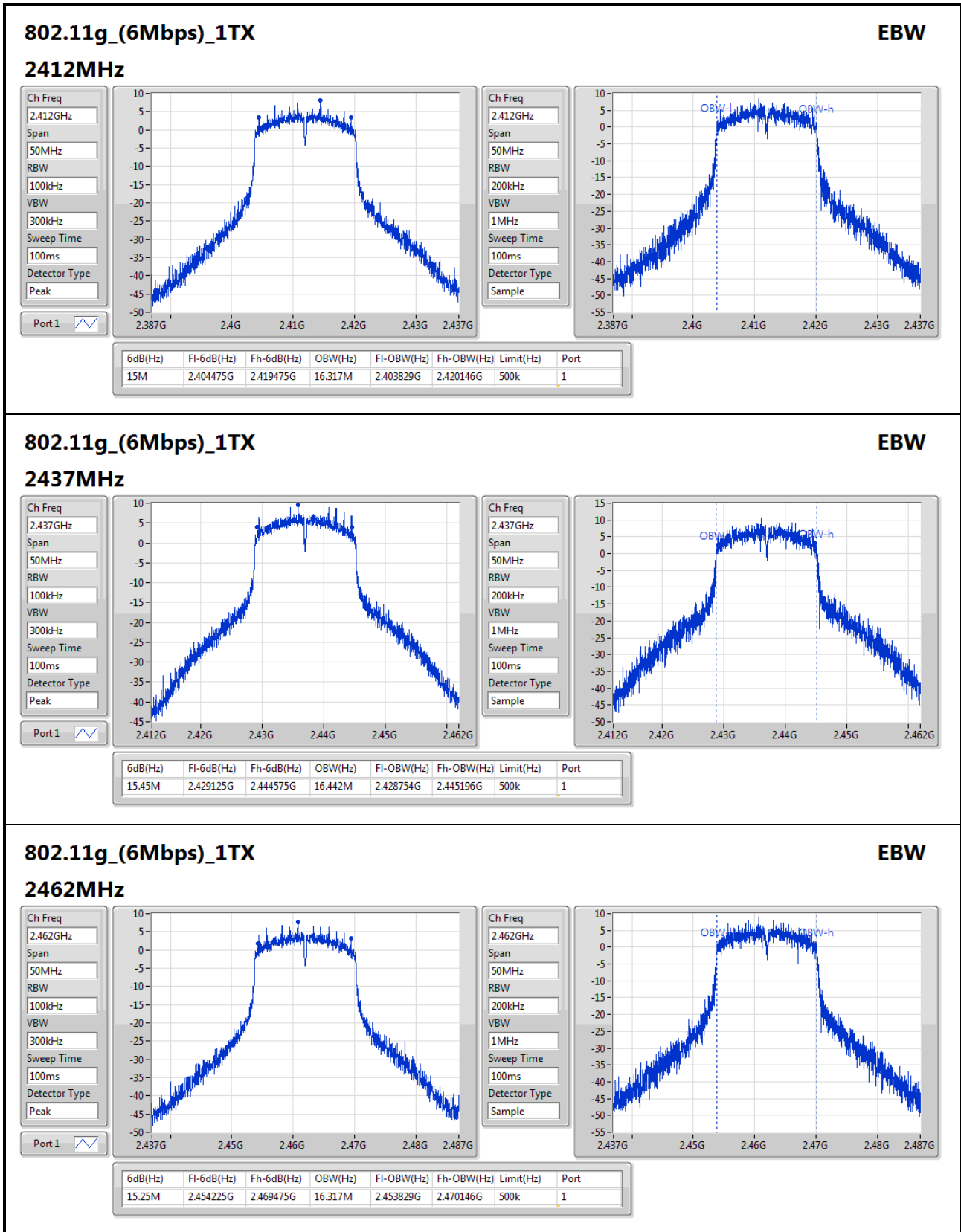



Summary

Mode	Total Power (dBm)	Total Power (W)
802.11b_(1Mbps)_1TX	-	-
2.4-2.4835GHz	21.78	0.15066
802.11g_(6Mbps)_1TX	-	-
2.4-2.4835GHz	24.67	0.29309

Result

Mode	Result	DG (dBi)	Port 1 (dBm)	Total Power (dBm)	Power Limit (dBm)
802.11b_(1Mbps)_1TX	-	-	-	-	-
2412MHz	Pass	1.38	21.78	21.78	30.00
2437MHz	Pass	1.38	21.67	21.67	30.00
2462MHz	Pass	1.38	21.65	21.65	30.00
802.11g_(6Mbps)_1TX	-	-	-	-	-
2412MHz	Pass	1.38	24.47	24.47	30.00
2437MHz	Pass	1.38	24.67	24.67	30.00
2462MHz	Pass	1.38	24.06	24.06	30.00

DG = Directional Gain; Port X = Port X output power



Summary

Mode	Total Power (dBm)	Total Power (W)
802.11b_(1Mbps)_1TX	-	-
2.4-2.4835GHz	19.48	0.08872
802.11g_(6Mbps)_1TX	-	-
2.4-2.4835GHz	19.25	0.08414

Result

Mode	Result	DG (dBi)	Port 1 (dBm)	Total Power (dBm)	Power Limit (dBm)
802.11b_(1Mbps)_1TX	-	-	-	-	-
2412MHz	Pass	1.38	19.47	19.47	30.00
2437MHz	Pass	1.38	19.48	19.48	30.00
2462MHz	Pass	1.38	19.30	19.30	30.00
802.11g_(6Mbps)_1TX	-	-	-	-	-
2412MHz	Pass	1.38	17.42	17.42	30.00
2437MHz	Pass	1.38	19.25	19.25	30.00
2462MHz	Pass	1.38	17.16	17.16	30.00

DG = Directional Gain; Port X = Port X output power



Summary

Mode	PD (dBm/RBW)
802.11b_(1Mbps)_1TX 2.4-2.4835GHz	- -0.85
802.11g_(6Mbps)_1TX 2.4-2.4835GHz	- -5.33

RBW=3kHz.

Result

Mode	Result	DG (dBi)	Port 1 (dBm/RBW)	PD (dBm/RBW)	PD Limit (dBm/RBW)
802.11b_(1Mbps)_1TX	-	-	-	-	-
2412MHz	Pass	1.38	-1.63	-1.63	8.00
2437MHz	Pass	1.38	-1.53	-1.53	8.00
2462MHz	Pass	1.38	-0.85	-0.85	8.00
802.11g_(6Mbps)_1TX	-	-	-	-	-
2412MHz	Pass	1.38	-7.16	-7.16	8.00
2437MHz	Pass	1.38	-5.33	-5.33	8.00
2462MHz	Pass	1.38	-7.86	-7.86	8.00

DG = Directional Gain; RBW=3kHz;

PD = trace bin-by-bin of each transmits port summing can be performed maximum power density; Port X = Port X power density;

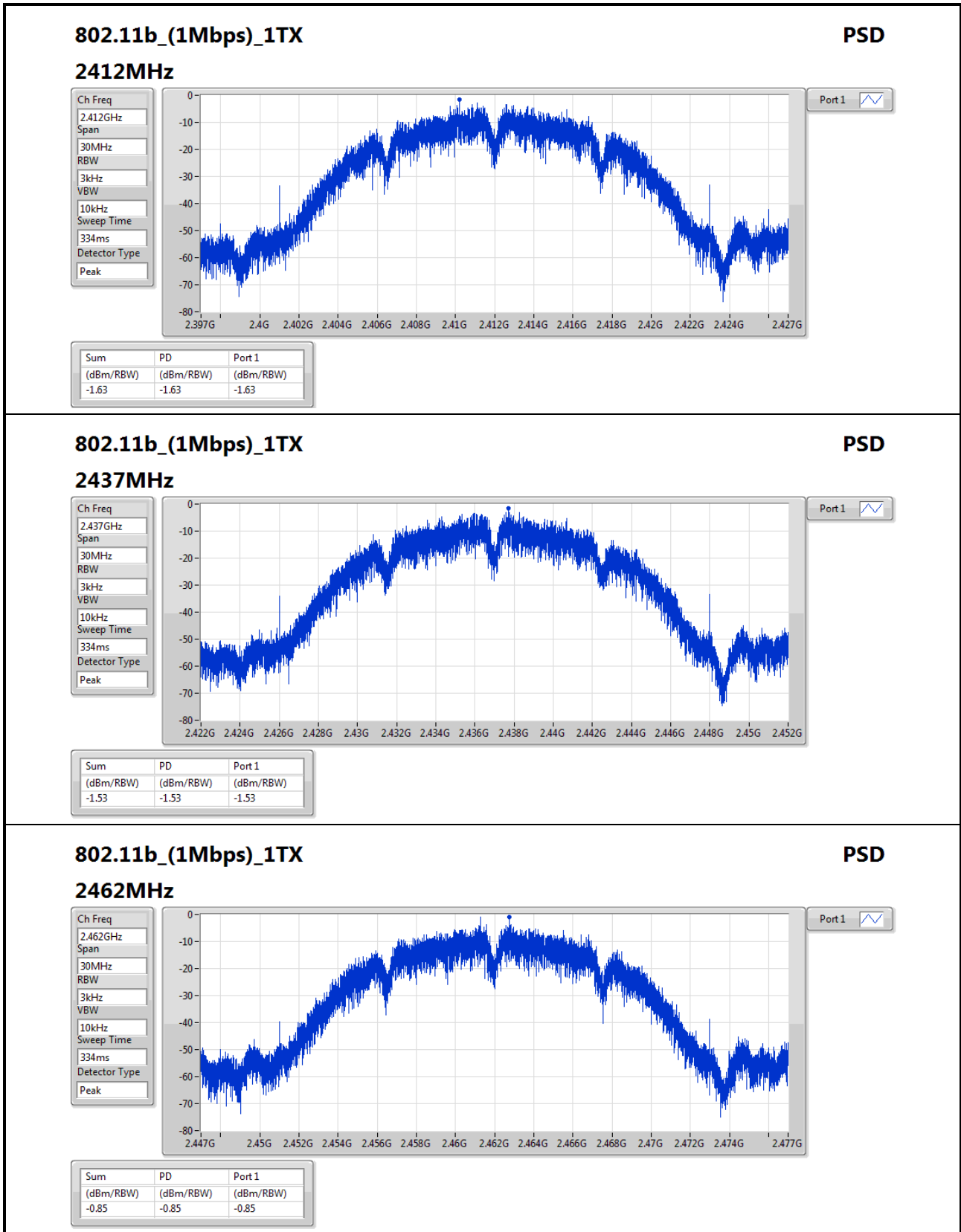

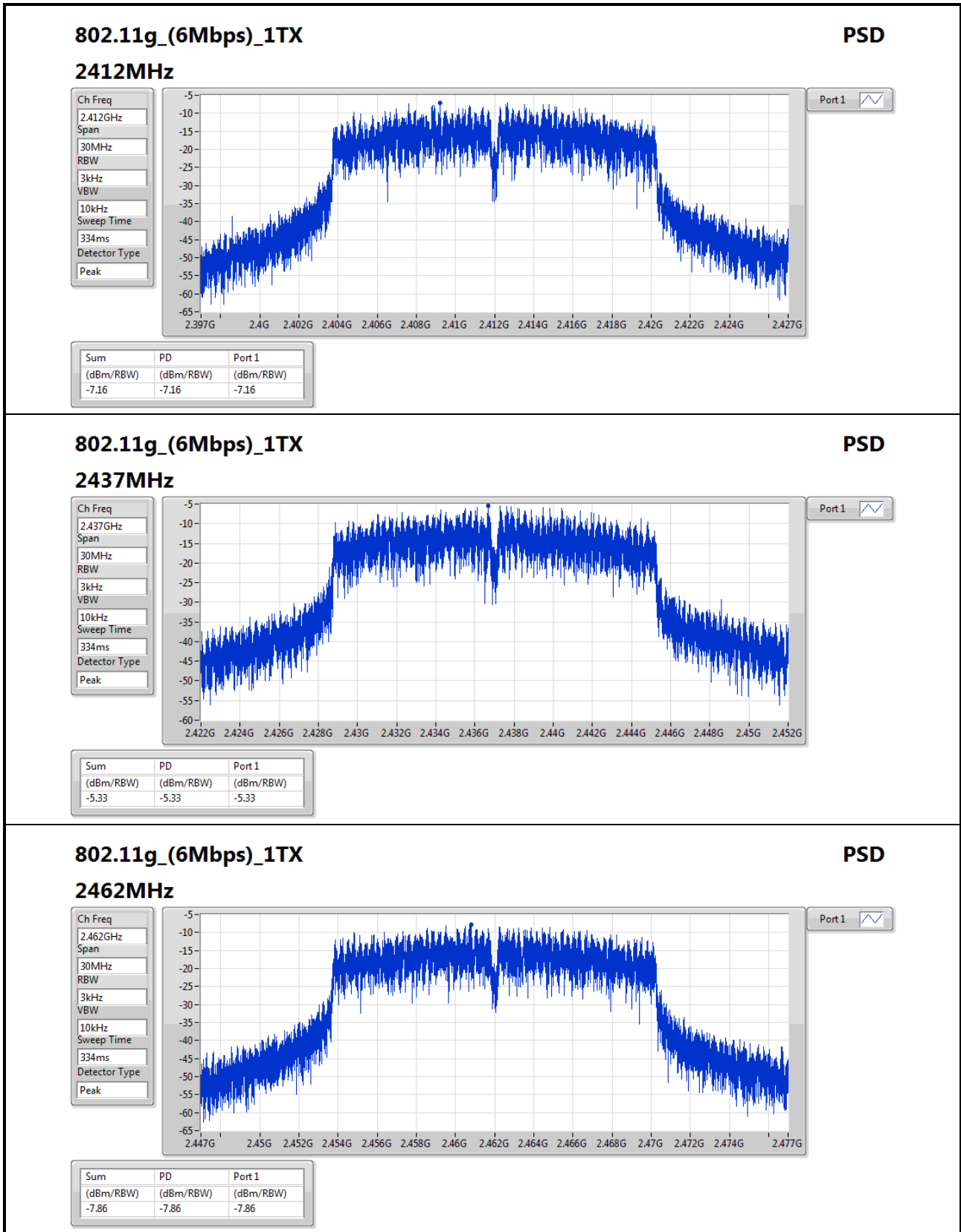



Summary

Mode	Result	Ref (Hz)	Ref (dBm)	Limit (dBm)	Freq (Hz)	Level (dBm)	Freq (Hz)	Level (dBm)	Freq (Hz)	Level (dBm)	Freq (Hz)	Level (dBm)	Port
802.11g_(6Mbps)_1TX	-	-	-	-	-	-	-	-	-	-	-	-	-
2.4-2.4835GHz	Pass	2.41002G	5.03	-14.97	2.18991G	-57.28	2.3996G	-24.05	2.48798G	-55.40	7.235136G	-44.54	1

Result

Mode	Result	Ref (Hz)	Ref (dBm)	Limit (dBm)	Freq (Hz)	Level (dBm)	Freq (Hz)	Level (dBm)	Freq (Hz)	Level (dBm)	Freq (Hz)	Level (dBm)	Port
802.11b_(1Mbps)_1TX	-	-	-	-	-	-	-	-	-	-	-	-	-
2412MHz	Pass	2.413026G	12.25	-7.75	2.18758G	-53.66	2.39808G	-35.35	2.48582G	-52.66	7.235136G	-39.71	1
2437MHz	Pass	2.437408G	11.89	-8.11	2.137485G	-56.99	2.398G	-46.05	2.51278G	-52.29	9.746885G	-43.21	1
2462MHz	Pass	2.461623G	11.23	-8.77	2.309905G	-50.96	2.39024G	-52.98	2.49046G	-43.61	9.848029G	-41.74	1
802.11g_(6Mbps)_1TX	-	-	-	-	-	-	-	-	-	-	-	-	-
2412MHz	Pass	2.41002G	5.03	-14.97	2.18991G	-57.28	2.3996G	-24.05	2.48798G	-55.40	7.235136G	-44.54	1
2437MHz	Pass	2.440748G	9.08	-10.92	2.139815G	-58.64	2.39768G	-47.14	2.48478G	-50.07	6.816512G	-54.03	1
2462MHz	Pass	2.459619G	6.63	-13.37	2.309905G	-55.47	2.39392G	-50.29	2.48358G	-38.83	6.971037G	-52.63	1

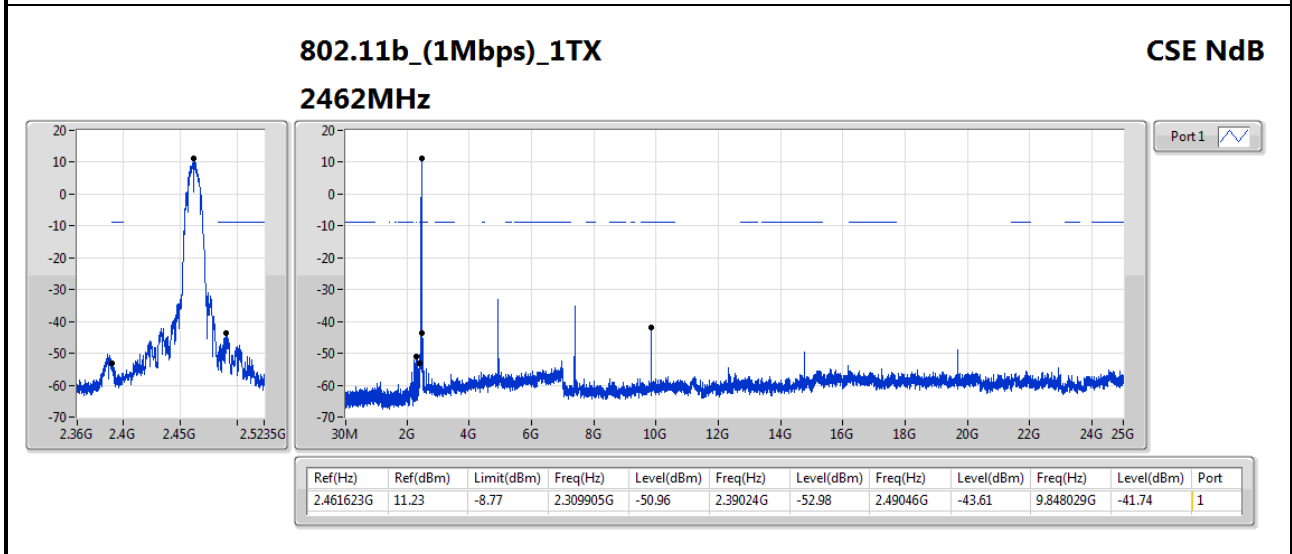
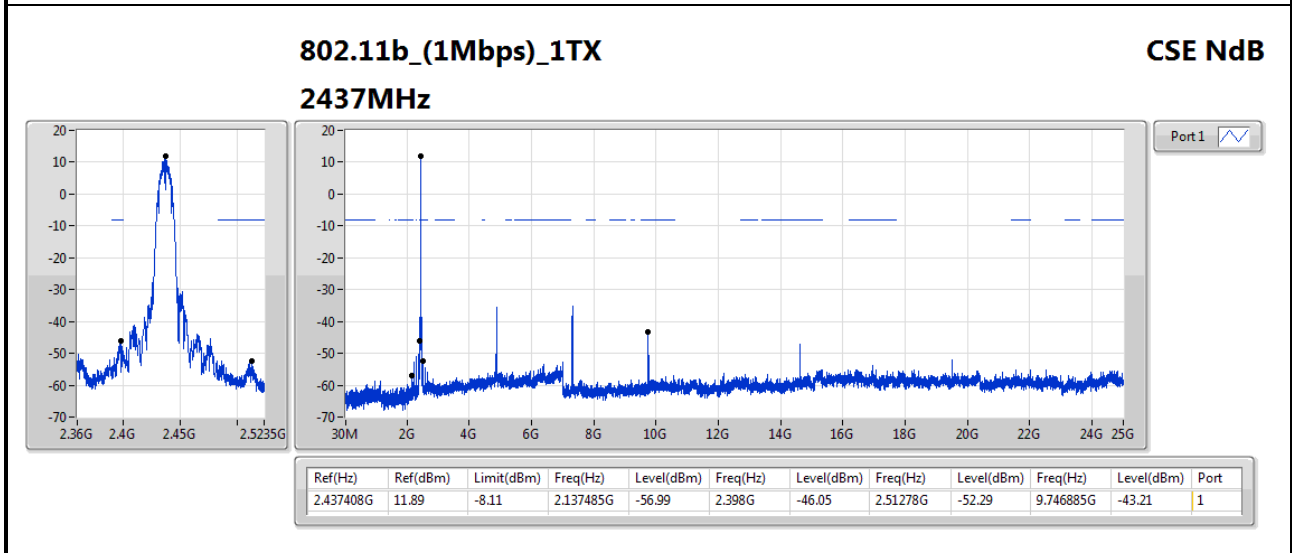
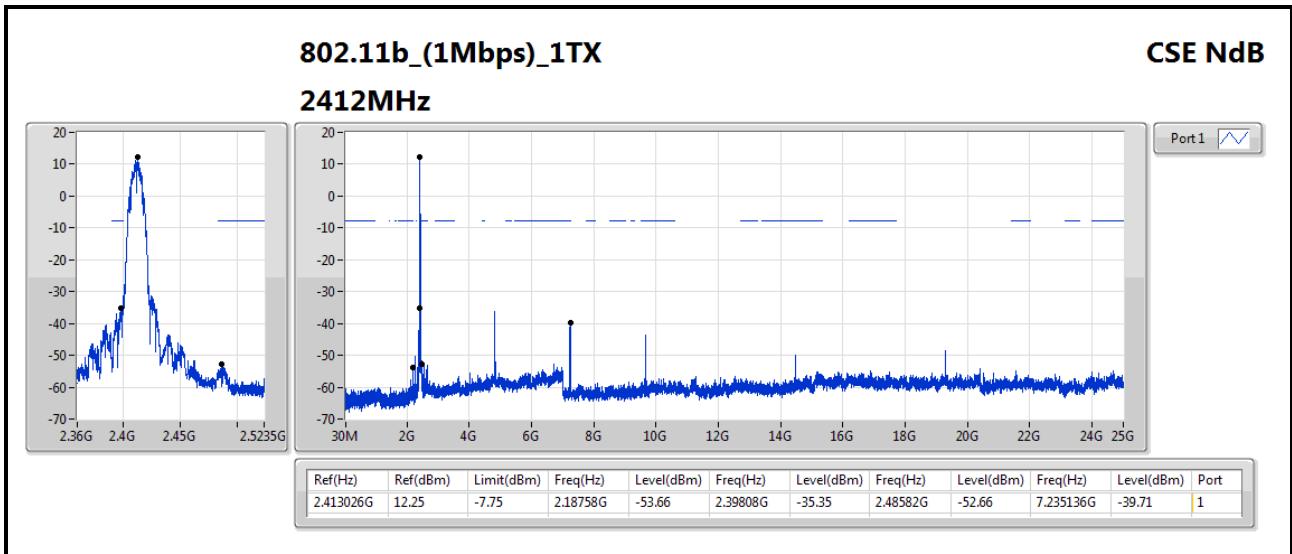

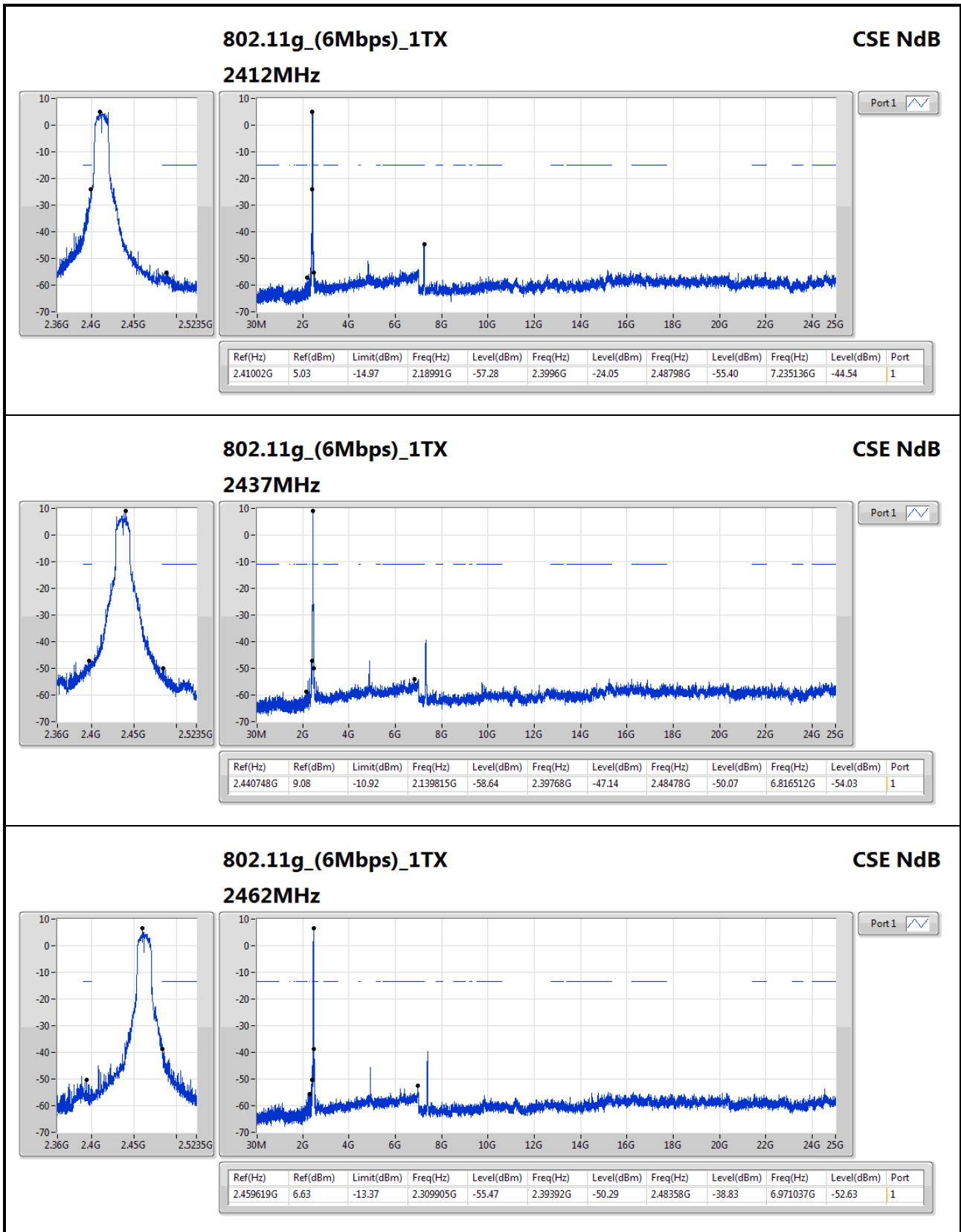



Summary

Mode	Result	Type	Freq (Hz)	Level (dBuV/m)	Limit (dBuV/m)	Margin (dB)	Factor (dB)	Dist (m)	Pol. (H/V)	Azimuth (°)	Height (m)	Comments
802.11g_(6Mbps)_1TX	-	-	-	-	-	-	-	-	-	-	-	-
2.4-2.4835GHz	Pass	QP	328.76M	42.88	46.00	-3.12	-6.03	3	H	94	1.00	-



Result

Mode	Result	Type	Freq (Hz)	Level (dBuV/m)	Limit (dBuV/m)	Margin (dB)	Factor (dB)	Dist (m)	Pol. (H/V)	Azimuth (°)	Height (m)	Comments
802.11g_(6Mbps)_1TX	-	-	-	-	-	-	-	-	-	-	-	-
2437MHz	Pass	PK	198.78M	33.00	43.50	-10.50	-10.90	3	H	360	1.00	-
2437MHz	Pass	PK	216.24M	33.38	46.00	-12.62	-10.96	3	H	360	1.00	-
2437MHz	Pass	PK	249.22M	39.29	46.00	-6.71	-7.56	3	H	360	1.00	-
2437MHz	Pass	PK	383.08M	41.86	46.00	-4.14	-4.45	3	H	360	1.00	-
2437MHz	Pass	PK	419.94M	42.07	46.00	-3.93	-3.60	3	H	360	1.00	-
2437MHz	Pass	QP	328.76M	42.88	46.00	-3.12	-6.03	3	H	94	1.00	-
2437MHz	Pass	PK	144.46M	32.64	43.50	-10.86	-10.06	3	V	0	1.00	-
2437MHz	Pass	PK	198.78M	31.76	43.50	-11.74	-10.90	3	V	0	1.00	-
2437MHz	Pass	PK	216.24M	38.43	46.00	-7.57	-10.96	3	V	0	1.00	-
2437MHz	Pass	PK	322.94M	39.93	46.00	-6.07	-6.04	3	V	0	1.00	-
2437MHz	Pass	PK	371.44M	39.24	46.00	-6.76	-4.78	3	V	0	1.00	-
2437MHz	Pass	PK	439.34M	41.17	46.00	-4.83	-3.23	3	V	0	1.00	-

802.11g_(6Mbps)_1TX

2437MHz_Adapter

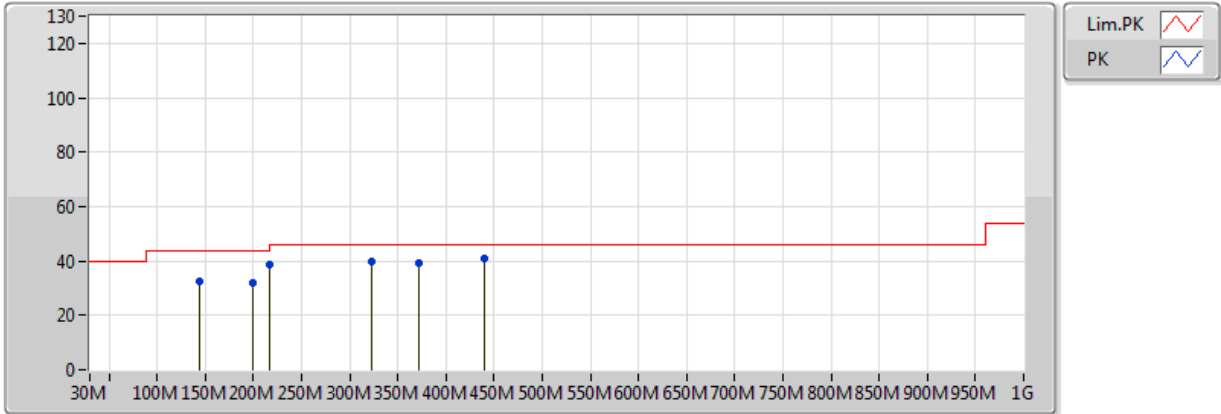

EUT = Y

Type	Freq(Hz)	Level(dBuV/m)	Limit(dBuV/m)	Margin(dB)	Factor(dB)	Dist(m)	Pol.(H/V)	Azimuth(°)	Height(m)	Comments
PK	144.46M	32.64	43.50	-10.86	-10.06	3	V	0	1.00	-
PK	198.78M	31.76	43.50	-11.74	-10.90	3	V	0	1.00	-
PK	216.24M	38.43	46.00	-7.57	-10.96	3	V	0	1.00	-
PK	322.94M	39.93	46.00	-6.07	-6.04	3	V	0	1.00	-
PK	371.44M	39.24	46.00	-6.76	-4.78	3	V	0	1.00	-
PK	439.34M	41.17	46.00	-4.83	-3.23	3	V	0	1.00	-

802.11g_(6Mbps)_1TX

2437MHz_Adapter

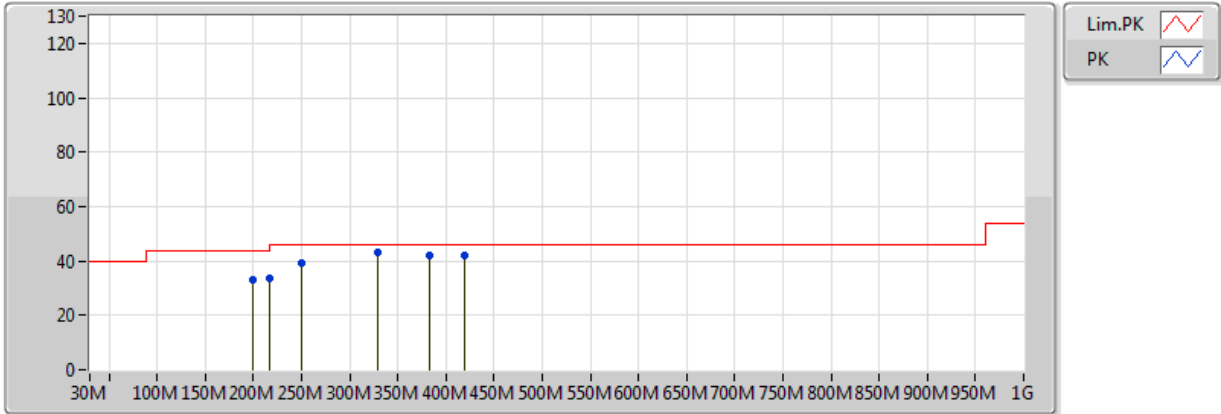

EUT = Y

Type	Freq(Hz)	Level(dBuV/m)	Limit(dBuV/m)	Margin(dB)	Factor(dB)	Dist(m)	Pol.(H/V)	Azimuth(°)	Height(m)	Comments
PK	198.78M	33.00	43.50	-10.50	-10.90	3	H	360	1.00	-
PK	216.24M	33.38	46.00	-12.62	-10.96	3	H	360	1.00	-
PK	249.22M	39.29	46.00	-6.71	-7.56	3	H	360	1.00	-
QP	328.76M	42.88	46.00	-3.12	-6.03	3	H	94	1.00	-
PK	383.08M	41.86	46.00	-4.14	-4.45	3	H	360	1.00	-
PK	419.94M	42.07	46.00	-3.93	-3.60	3	H	360	1.00	-



Summary

Mode	Result	Type	Freq (Hz)	Level (dBuV/m)	Limit (dBuV/m)	Margin (dB)	Factor (dB)	Dist (m)	Pol. (H/V)	Azimuth (°)	Height (m)	Comments
802.11g_(6Mbps)_1TX	-	-	-	-	-	-	-	-	-	-	-	-
2.4-2.4835GHz	Pass	PK	2.483502G	73.38	74.00	-0.62	30.53	3	H	120	1.32	-



Result

Mode	Result	Type	Freq (Hz)	Level (dBuV/m)	Limit (dBuV/m)	Margin (dB)	Factor (dB)	Dist (m)	Pol. (H/V)	Azimuth (°)	Height (m)	Comments
802.11b_(1Mbps)_1TX	-	-	-	-	-	-	-	-	-	-	-	-
2412MHz	Pass	AV	2.3852G	51.65	54.00	-2.35	30.21	3	H	132	3.45	-
2412MHz	Pass	AV	2.4112G	104.77	Inf	-Inf	30.30	3	H	132	3.45	-
2412MHz	Pass	PK	2.3846G	59.54	74.00	-14.46	30.21	3	H	132	3.45	-
2412MHz	Pass	PK	2.413G	109.65	Inf	-Inf	30.30	3	H	132	3.45	-
2412MHz	Pass	AV	2.3852G	52.19	54.00	-1.81	30.21	3	V	54	2.51	-
2412MHz	Pass	AV	2.4112G	104.86	Inf	-Inf	30.30	3	V	54	2.51	-
2412MHz	Pass	PK	2.3858G	60.41	74.00	-13.59	30.22	3	V	54	2.51	-
2412MHz	Pass	PK	2.4108G	109.56	Inf	-Inf	30.29	3	V	54	2.51	-
2412MHz	Pass	AV	4.824G	34.17	54.00	-19.83	0.95	3	H	207	1.47	-
2412MHz	Pass	PK	4.824G	48.69	74.00	-39.83	0.95	3	H	207	1.47	-
2412MHz	Pass	AV	4.824G	34.61	54.00	-19.39	0.95	3	V	184	1.37	-
2412MHz	Pass	PK	4.824G	44.28	74.00	-29.72	0.95	3	V	184	1.37	-
2437MHz	Pass	AV	2.3886G	43.20	54.00	-10.80	30.22	3	H	106	1.54	-
2437MHz	Pass	AV	2.4362G	104.08	Inf	-Inf	30.38	3	H	106	1.54	-
2437MHz	Pass	AV	2.4874G	44.01	54.00	-9.99	30.54	3	H	106	1.54	-
2437MHz	Pass	PK	2.373G	54.74	74.00	-19.26	30.18	3	H	106	1.54	-
2437MHz	Pass	PK	2.4382G	108.89	Inf	-Inf	30.38	3	H	106	1.54	-
2437MHz	Pass	PK	2.4894G	55.37	74.00	-18.63	30.55	3	H	106	1.54	-
2437MHz	Pass	AV	2.3882G	43.25	54.00	-10.75	30.22	3	V	45	1.80	-
2437MHz	Pass	AV	2.4362G	103.94	Inf	-Inf	30.38	3	V	45	1.80	-
2437MHz	Pass	AV	2.499998G	43.85	54.00	-10.15	30.58	3	V	45	1.80	-
2437MHz	Pass	PK	2.3614G	54.83	74.00	-19.17	30.14	3	V	45	1.80	-
2437MHz	Pass	PK	2.4382G	108.76	Inf	-Inf	30.38	3	V	45	1.80	-
2437MHz	Pass	PK	2.4958G	55.94	74.00	-18.06	30.57	3	V	45	1.80	-
2437MHz	Pass	AV	4.874G	34.09	54.00	-19.91	1.06	3	H	166	1.47	-
2437MHz	Pass	PK	4.874G	44.97	74.00	-29.03	1.06	3	H	166	1.47	-
2437MHz	Pass	AV	4.874G	32.61	54.00	-21.39	1.06	3	V	197	1.29	-
2437MHz	Pass	PK	4.874G	44.96	74.00	-29.04	1.06	3	V	197	1.29	-
2462MHz	Pass	AV	2.4612G	105.77	Inf	-Inf	30.46	3	H	120	1.44	-
2462MHz	Pass	AV	2.4906G	48.14	54.00	-5.86	30.55	3	H	120	1.44	-
2462MHz	Pass	PK	2.461G	109.81	Inf	-Inf	30.46	3	H	120	1.44	-
2462MHz	Pass	PK	2.4894G	59.00	74.00	-15.00	30.55	3	H	120	1.44	-
2462MHz	Pass	AV	2.4612G	103.14	Inf	-Inf	30.46	3	V	187	1.15	-
2462MHz	Pass	AV	2.4876G	46.50	54.00	-7.50	30.54	3	V	187	1.15	-
2462MHz	Pass	PK	2.463G	107.30	Inf	-Inf	30.46	3	V	187	1.15	-
2462MHz	Pass	PK	2.4864G	57.71	74.00	-16.29	30.54	3	V	187	1.15	-
2462MHz	Pass	AV	4.924G	33.37	54.00	-20.63	1.17	3	H	348	2.61	-
2462MHz	Pass	PK	4.924G	43.77	74.00	-30.23	1.17	3	H	348	2.61	-
2462MHz	Pass	AV	4.924G	34.72	54.00	-19.28	1.12	3	V	198	1.52	-
2462MHz	Pass	PK	4.924G	44.83	74.00	-29.17	1.17	3	V	198	1.52	-
802.11g_(6Mbps)_1TX	-	-	-	-	-	-	-	-	-	-	-	-
2412MHz	Pass	AV	2.39G	52.06	54.00	-1.94	30.23	3	H	115	1.55	-
2412MHz	Pass	AV	2.4134G	98.50	Inf	-Inf	30.30	3	H	115	1.55	-
2412MHz	Pass	PK	2.3884G	73.23	74.00	-0.77	30.22	3	H	115	1.55	-
2412MHz	Pass	PK	2.4118G	109.95	Inf	-Inf	30.30	3	H	115	1.55	-
2412MHz	Pass	AV	2.39G	48.93	54.00	-5.07	30.23	3	V	52	3.34	-
2412MHz	Pass	AV	2.4136G	98.06	Inf	-Inf	30.30	3	V	52	3.34	-



RSE TX above 1GHz Result

Appendix F

Mode	Result	Type	Freq (Hz)	Level (dBuV/m)	Limit (dBuV/m)	Margin (dB)	Factor (dB)	Dist (m)	Pol. (H/V)	Azimuth (°)	Height (m)	Comments
2412MHz	Pass	PK	2.39G	68.40	74.00	-5.60	30.23	3	V	52	3.34	-
2412MHz	Pass	PK	2.4166G	109.72	Inf	-Inf	30.31	3	V	52	3.34	-
2412MHz	Pass	AV	4.824G	28.46	54.00	-25.54	0.95	3	H	0	1.50	-
2412MHz	Pass	PK	4.824G	42.96	74.00	-31.04	0.95	3	H	0	1.50	-
2412MHz	Pass	AV	4.824G	28.45	54.00	-25.55	0.95	3	V	360	1.50	-
2412MHz	Pass	PK	4.824G	42.11	74.00	-31.89	0.95	3	V	360	1.50	-
2437MHz	Pass	AV	2.389998G	42.96	54.00	-11.04	30.23	3	H	NaN	NaN	-
2437MHz	Pass	AV	2.4382G	99.32	Inf	-Inf	30.38	3	H	NaN	NaN	-
2437MHz	Pass	AV	2.4846G	44.10	54.00	-9.90	30.53	3	H	NaN	NaN	-
2437MHz	Pass	PK	2.3878G	62.36	74.00	-11.64	30.22	3	H	NaN	NaN	-
2437MHz	Pass	PK	2.437G	110.47	Inf	-Inf	30.38	3	H	NaN	NaN	-
2437MHz	Pass	PK	2.4858G	63.93	74.00	-10.07	30.53	3	H	NaN	NaN	-
2437MHz	Pass	AV	2.389998G	42.28	54.00	-11.72	30.23	3	V	190	1.15	-
2437MHz	Pass	AV	2.4402G	95.55	Inf	-Inf	30.39	3	V	190	1.15	-
2437MHz	Pass	AV	2.4846G	43.10	54.00	-10.90	30.53	3	V	190	1.15	-
2437MHz	Pass	PK	2.3858G	58.71	74.00	-15.29	30.22	3	V	190	1.15	-
2437MHz	Pass	PK	2.4402G	107.32	Inf	-Inf	30.39	3	V	190	1.15	-
2437MHz	Pass	PK	2.485G	59.63	74.00	-14.37	30.53	3	V	190	1.15	-
2437MHz	Pass	AV	4.874G	28.52	54.00	-25.48	1.06	3	H	0	1.50	-
2437MHz	Pass	PK	4.874G	42.63	74.00	-31.37	1.06	3	H	0	1.50	-
2437MHz	Pass	AV	4.874G	28.70	54.00	-25.30	1.06	3	V	360	1.50	-
2437MHz	Pass	PK	4.874G	42.68	74.00	-31.32	1.06	3	V	360	1.50	-
2462MHz	Pass	AV	2.4608G	97.86	Inf	-Inf	30.45	3	H	120	1.32	-
2462MHz	Pass	AV	2.483502G	51.67	54.00	-2.33	30.53	3	H	120	1.32	-
2462MHz	Pass	PK	2.462G	110.06	Inf	-Inf	30.46	3	H	120	1.32	-
2462MHz	Pass	PK	2.483502G	73.38	74.00	-0.62	30.53	3	H	120	1.32	-
2462MHz	Pass	AV	2.463G	94.39	Inf	-Inf	30.46	3	V	187	1.39	-
2462MHz	Pass	AV	2.483502G	49.04	54.00	-4.96	30.53	3	V	187	1.39	-
2462MHz	Pass	PK	2.4622G	105.75	Inf	-Inf	30.46	3	V	187	1.39	-
2462MHz	Pass	PK	2.4836G	68.30	74.00	-5.70	30.53	3	V	187	1.39	-
2462MHz	Pass	AV	4.924G	28.84	54.00	-25.16	1.17	3	H	360	1.50	-
2462MHz	Pass	PK	4.924G	42.80	74.00	-31.20	1.17	3	H	360	1.50	-
2462MHz	Pass	AV	4.924G	28.82	54.00	-25.18	1.17	3	V	0	1.50	-
2462MHz	Pass	PK	4.924G	43.20	74.00	-30.80	1.17	3	V	0	1.50	-

802.11b_(1Mbps)_1TX

2412MHz_TX

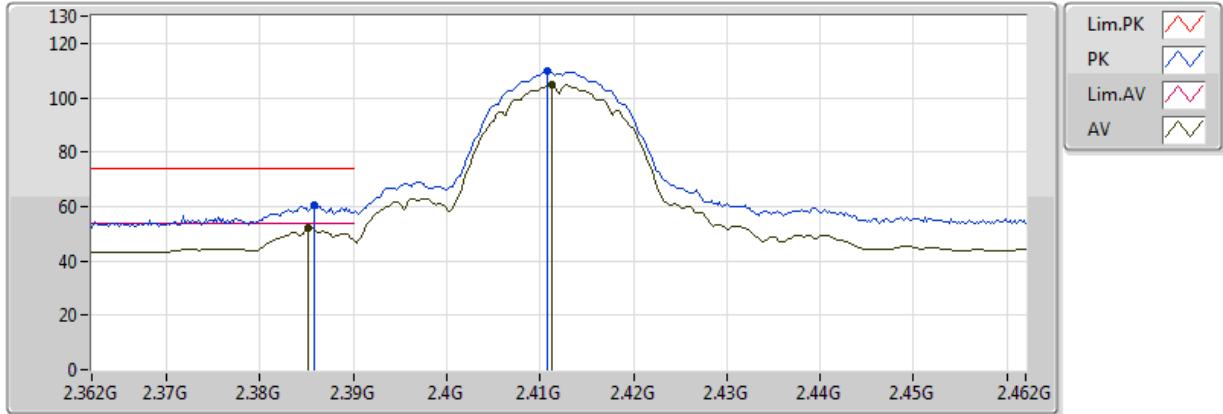

EUT = Y

Type	Freq(Hz)	Level(dBuV/m)	Limit(dBuV/m)	Margin(dB)	Factor(dB)	Dist(m)	Pol.(H/V)	Azimuth(°)	Height(m)	Comments
AV	2.3852G	52.19	54.00	-1.81	30.21	3	V	54	2.51	-
AV	2.4112G	104.86	Inf	-Inf	30.30	3	V	54	2.51	-
PK	2.3858G	60.41	74.00	-13.59	30.22	3	V	54	2.51	-
PK	2.4108G	109.56	Inf	-Inf	30.29	3	V	54	2.51	-

802.11b_(1Mbps)_1TX

2412MHz_TX

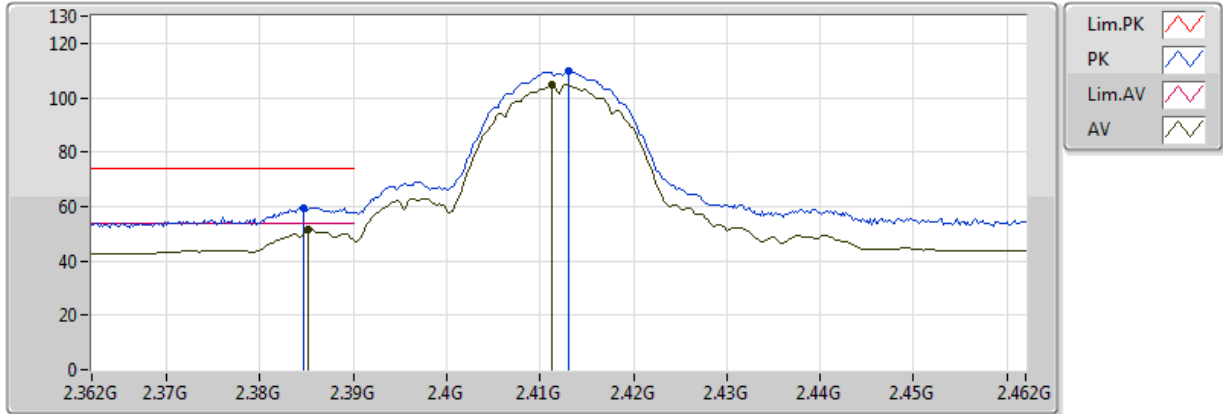

EUT = Y

Type	Freq(Hz)	Level(dBuV/m)	Limit(dBuV/m)	Margin(dB)	Factor(dB)	Dist(m)	Pol.(H/V)	Azimuth(°)	Height(m)	Comments
AV	2.3852G	51.65	54.00	-2.35	30.21	3	H	132	3.45	-
AV	2.4112G	104.77	Inf	-Inf	30.30	3	H	132	3.45	-
PK	2.3846G	59.54	74.00	-14.46	30.21	3	H	132	3.45	-
PK	2.413G	109.65	Inf	-Inf	30.30	3	H	132	3.45	-



802.11b_(1Mbps)_1TX

2412MHz_TX

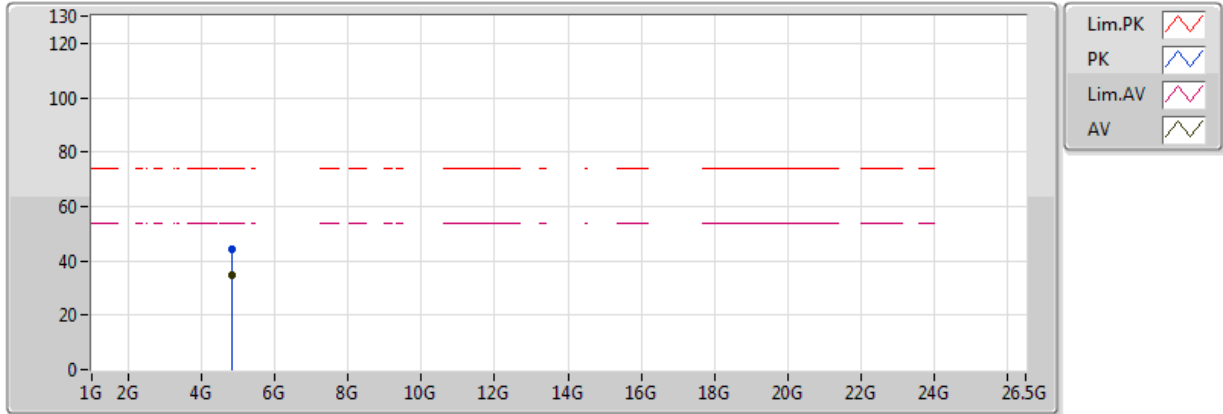

EUT = Y

Type	Freq(Hz)	Level(dBuV/m)	Limit(dBuV/m)	Margin(dB)	Factor(dB)	Dist(m)	Pol.(H/V)	Azimuth(°)	Height(m)	Comments
AV	4.824G	34.61	54.00	-19.39	0.95	3	V	184	1.37	-
PK	4.824G	44.28	74.00	-29.72	0.95	3	V	184	1.37	-

802.11b_(1Mbps)_1TX

2412MHz_TX

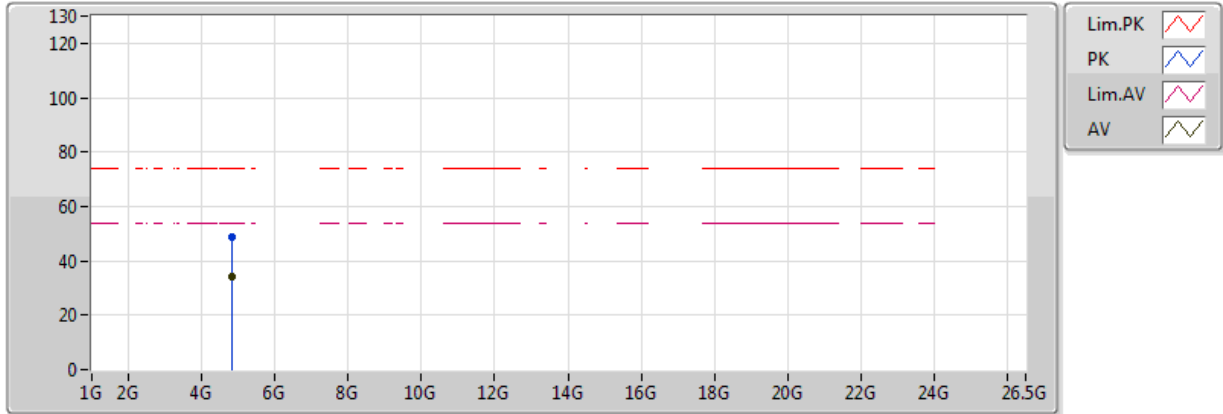

EUT = Y

Type	Freq(Hz)	Level(dBuV/m)	Limit(dBuV/m)	Margin(dB)	Factor(dB)	Dist(m)	Pol.(H/V)	Azimuth(°)	Height(m)	Comments
AV	4.824G	34.17	54.00	-19.83	0.95	3	H	207	1.47	-
PK	4.824G	48.69	74.00	-39.83	0.95	3	H	207	1.47	-

802.11b_(1Mbps)_1TX

2437MHz_TX

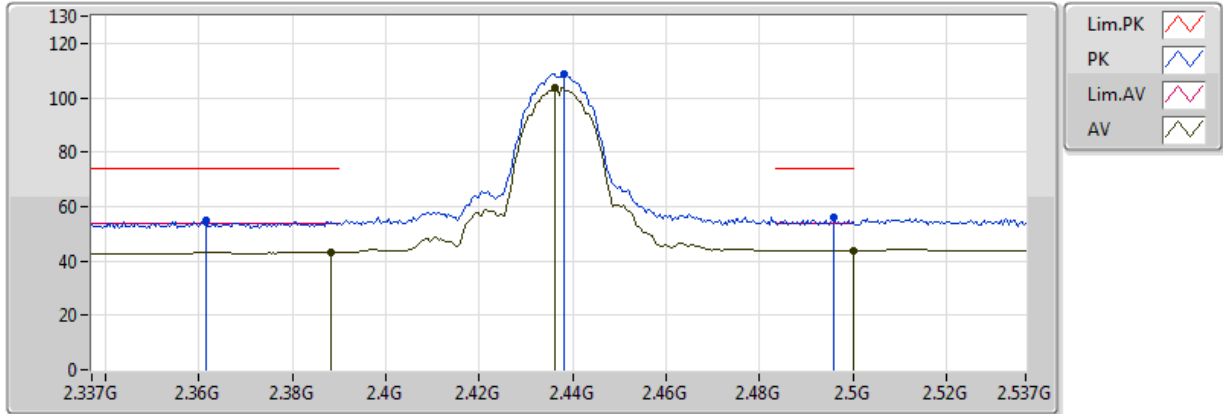

EUT = Y

Type	Freq(Hz)	Level(dBuV/m)	Limit(dBuV/m)	Margin(dB)	Factor(dB)	Dist(m)	Pol.(H/V)	Azimuth(°)	Height(m)	Comments
AV	2.3882G	43.25	54.00	-10.75	30.22	3	V	45	1.80	-
AV	2.4362G	103.94	Inf	-Inf	30.38	3	V	45	1.80	-
AV	2.499998G	43.85	54.00	-10.15	30.58	3	V	45	1.80	-
PK	2.3614G	54.83	74.00	-19.17	30.14	3	V	45	1.80	-
PK	2.4382G	108.76	Inf	-Inf	30.38	3	V	45	1.80	-
PK	2.4958G	55.94	74.00	-18.06	30.57	3	V	45	1.80	-

802.11b_(1Mbps)_1TX

2437MHz_TX

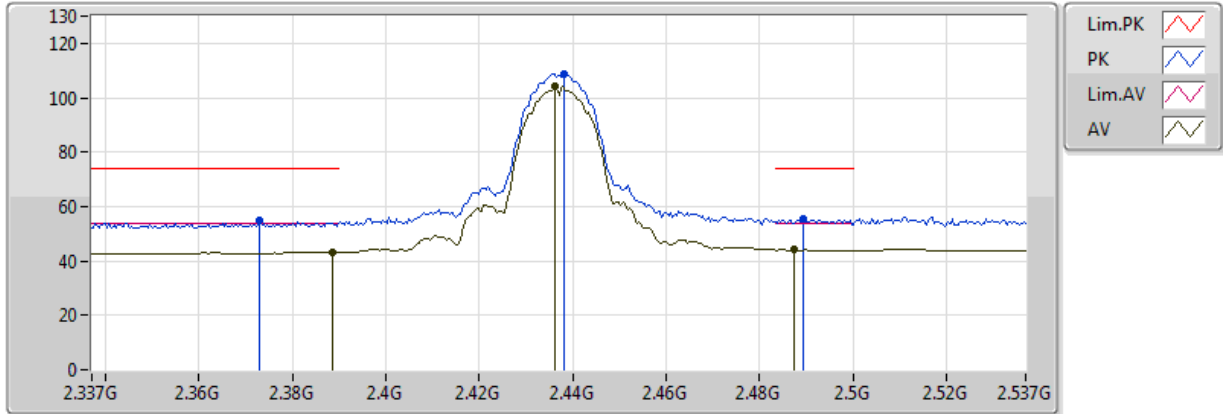

EUT = Y

Type	Freq(Hz)	Level(dBuV/m)	Limit(dBuV/m)	Margin(dB)	Factor(dB)	Dist(m)	Pol.(H/V)	Azimuth(°)	Height(m)	Comments
AV	2.3886G	43.20	54.00	-10.80	30.22	3	H	106	1.54	-
AV	2.4362G	104.08	Inf	-Inf	30.38	3	H	106	1.54	-
AV	2.4874G	44.01	54.00	-9.99	30.54	3	H	106	1.54	-
PK	2.373G	54.74	74.00	-19.26	30.18	3	H	106	1.54	-
PK	2.4382G	108.89	Inf	-Inf	30.38	3	H	106	1.54	-
PK	2.4894G	55.37	74.00	-18.63	30.55	3	H	106	1.54	-

802.11b_(1Mbps)_1TX

2437MHz_TX

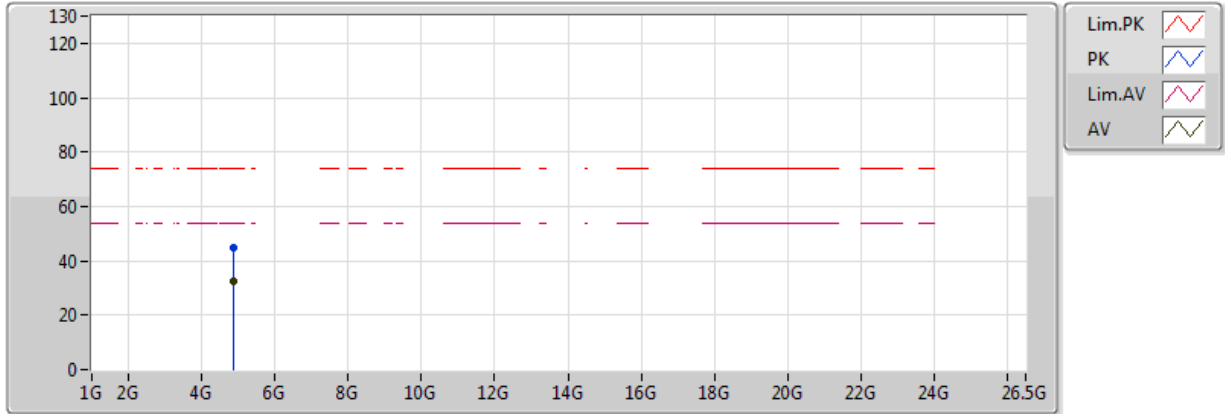

EUT = Y

Type	Freq(Hz)	Level(dBuV/m)	Limit(dBuV/m)	Margin(dB)	Factor(dB)	Dist(m)	Pol.(H/V)	Azimuth(°)	Height(m)	Comments
AV	4.874G	32.61	54.00	-21.39	1.06	3	V	197	1.29	-
PK	4.874G	44.96	74.00	-29.04	1.06	3	V	197	1.29	-

802.11b_(1Mbps)_1TX

2437MHz_TX

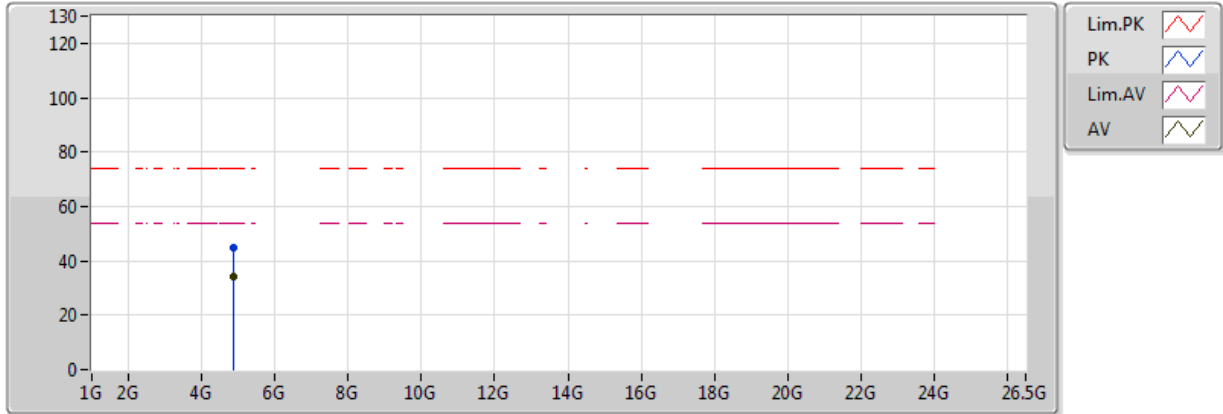

EUT = Y

Type	Freq(Hz)	Level(dBuV/m)	Limit(dBuV/m)	Margin(dB)	Factor(dB)	Dist(m)	Pol.(H/V)	Azimuth(°)	Height(m)	Comments
AV	4.874G	34.09	54.00	-19.91	1.06	3	H	166	1.47	-
PK	4.874G	44.97	74.00	-29.03	1.06	3	H	166	1.47	-

802.11b_(1Mbps)_1TX

2462MHz_TX

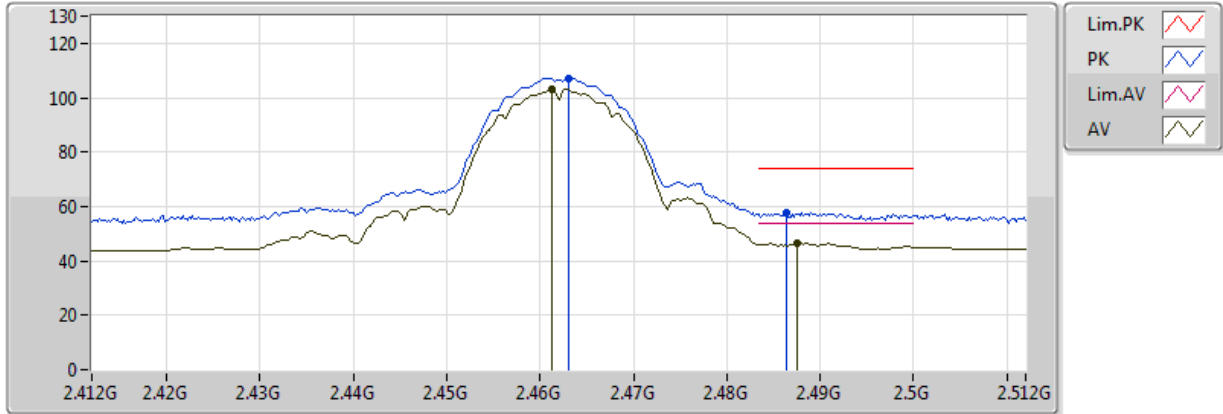

EUT = Y

Type	Freq(Hz)	Level(dBuV/m)	Limit(dBuV/m)	Margin(dB)	Factor(dB)	Dist(m)	Pol.(H/V)	Azimuth(°)	Height(m)	Comments
AV	2.4612G	103.14	Inf	-Inf	30.46	3	V	187	1.15	-
AV	2.4876G	46.50	54.00	-7.50	30.54	3	V	187	1.15	-
PK	2.463G	107.30	Inf	-Inf	30.46	3	V	187	1.15	-
PK	2.4864G	57.71	74.00	-16.29	30.54	3	V	187	1.15	-

802.11b_(1Mbps)_1TX

2462MHz_TX

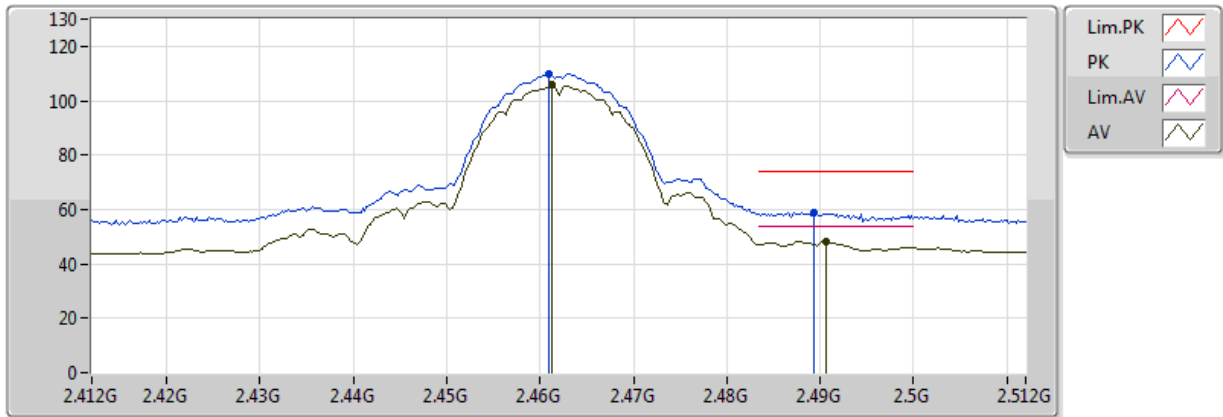

EUT = Y

Type	Freq(Hz)	Level(dBuV/m)	Limit(dBuV/m)	Margin(dB)	Factor(dB)	Dist(m)	Pol.(H/V)	Azimuth(°)	Height(m)	Comments
AV	2.4612G	105.77	Inf	-Inf	30.46	3	H	120	1.44	-
AV	2.4906G	48.14	54.00	-5.86	30.55	3	H	120	1.44	-
PK	2.461G	109.81	Inf	-Inf	30.46	3	H	120	1.44	-
PK	2.4894G	59.00	74.00	-15.00	30.55	3	H	120	1.44	-

802.11b_(1Mbps)_1TX

2462MHz_TX

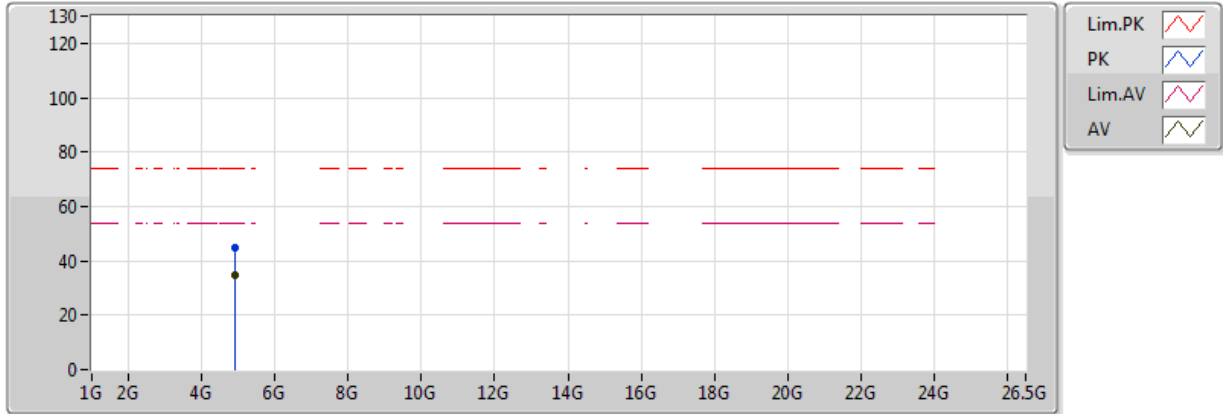

EUT = Y

Type	Freq(Hz)	Level(dBuV/m)	Limit(dBuV/m)	Margin(dB)	Factor(dB)	Dist(m)	Pol.(H/V)	Azimuth(°)	Height(m)	Comments
AV	4.924G	34.72	54.00	-19.28	1.17	3	V	198	1.52	-
PK	4.924G	44.83	74.00	-29.17	1.17	3	V	198	1.52	-

802.11b_(1Mbps)_1TX

2462MHz_TX

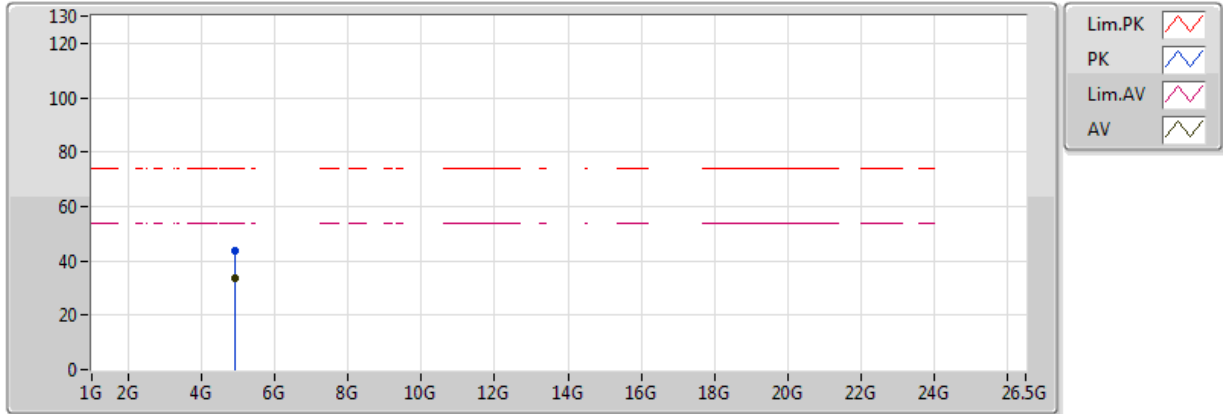

EUT = Y

Type	Freq(Hz)	Level(dBuV/m)	Limit(dBuV/m)	Margin(dB)	Factor(dB)	Dist(m)	Pol.(H/V)	Azimuth(°)	Height(m)	Comments
AV	4.924G	33.37	54.00	-20.63	1.17	3	H	348	2.61	-
PK	4.924G	43.77	74.00	-30.23	1.17	3	H	348	2.61	-

802.11g_(6Mbps)_1TX

2412MHz_TX

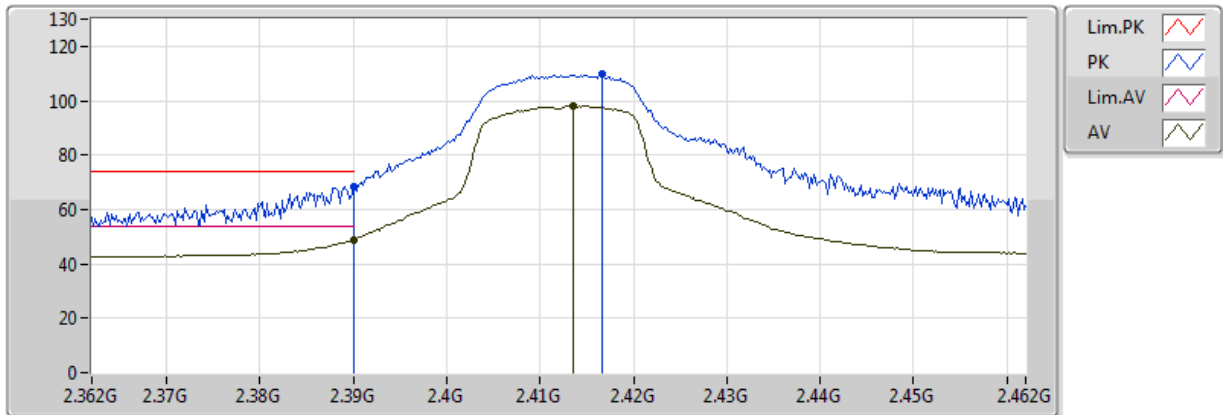

EUT = Y

Type	Freq(Hz)	Level(dBuV/m)	Limit(dBuV/m)	Margin(dB)	Factor(dB)	Dist(m)	Pol.(H/V)	Azimuth(°)	Height(m)	Comments
AV	2.39G	48.93	54.00	-5.07	30.23	3	V	52	3.34	-
AV	2.4136G	98.06	Inf	-Inf	30.30	3	V	52	3.34	-
PK	2.39G	68.40	74.00	-5.60	30.23	3	V	52	3.34	-
PK	2.4166G	109.72	Inf	-Inf	30.31	3	V	52	3.34	-

802.11g_(6Mbps)_1TX

2412MHz_TX

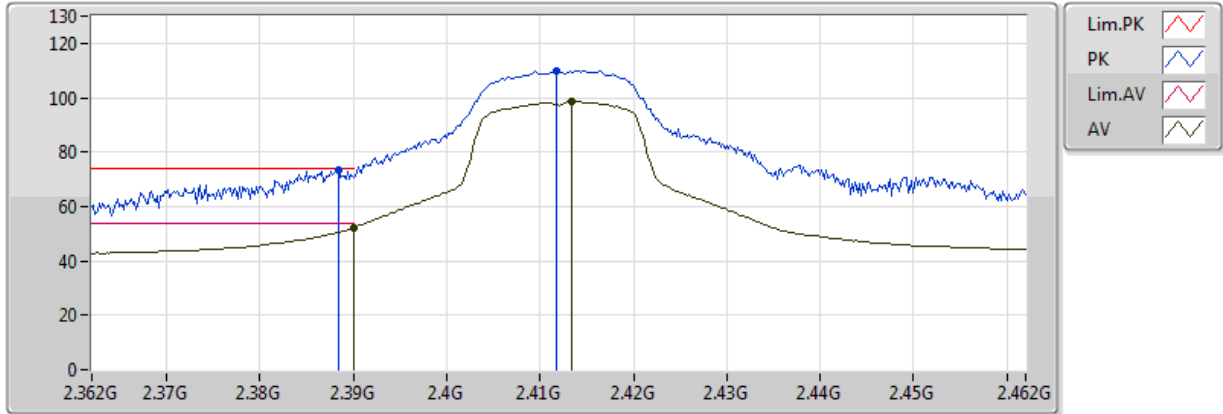

EUT = Y

Type	Freq(Hz)	Level(dBuV/m)	Limit(dBuV/m)	Margin(dB)	Factor(dB)	Dist(m)	Pol.(H/V)	Azimuth(°)	Height(m)	Comments
AV	2.39G	52.06	54.00	-1.94	30.23	3	H	115	1.55	-
AV	2.4134G	98.50	Inf	-Inf	30.30	3	H	115	1.55	-
PK	2.3884G	73.23	74.00	-0.77	30.22	3	H	115	1.55	-
PK	2.4118G	109.95	Inf	-Inf	30.30	3	H	115	1.55	-

802.11g_(6Mbps)_1TX

2412MHz_TX

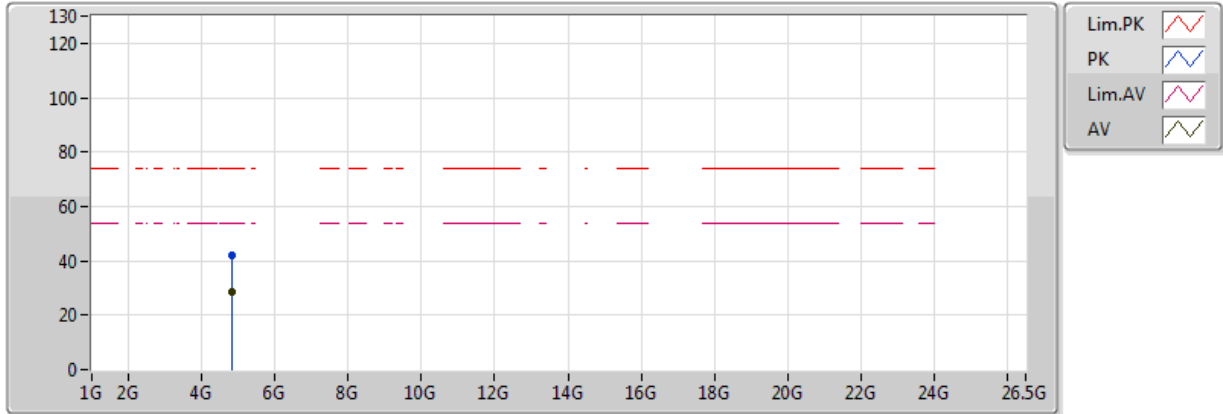

EUT = Y

Type	Freq(Hz)	Level(dBuV/m)	Limit(dBuV/m)	Margin(dB)	Factor(dB)	Dist(m)	Pol.(H/V)	Azimuth(°)	Height(m)	Comments
AV	4.824G	28.45	54.00	-25.55	0.95	3	V	360	1.50	-
PK	4.824G	42.11	74.00	-31.89	0.95	3	V	360	1.50	-

802.11g_(6Mbps)_1TX

2412MHz_TX

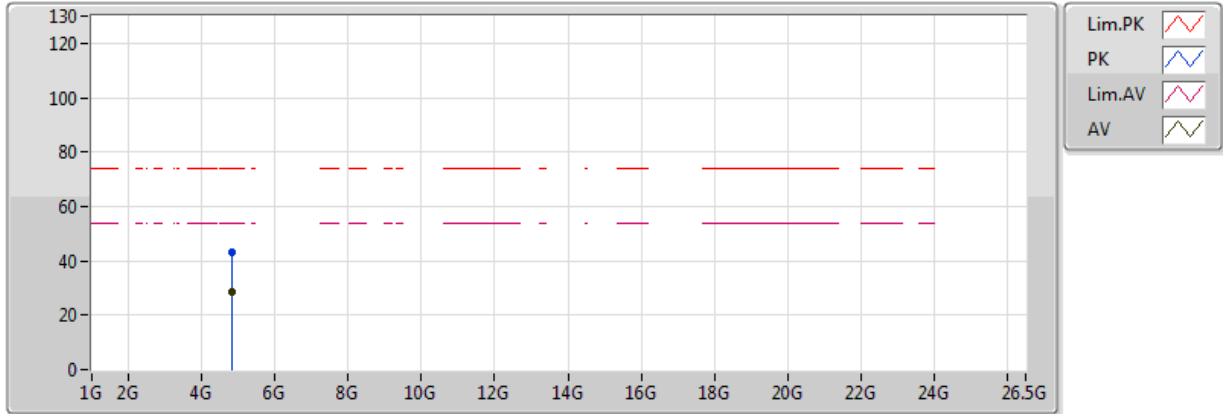

EUT = Y

Type	Freq(Hz)	Level(dBuV/m)	Limit(dBuV/m)	Margin(dB)	Factor(dB)	Dist(m)	Pol.(H/V)	Azimuth(°)	Height(m)	Comments
AV	4.824G	28.46	54.00	-25.54	0.95	3	H	0	1.50	-
PK	4.824G	42.96	74.00	-31.04	0.95	3	H	0	1.50	-

802.11g_(6Mbps)_1TX

2437MHz_TX

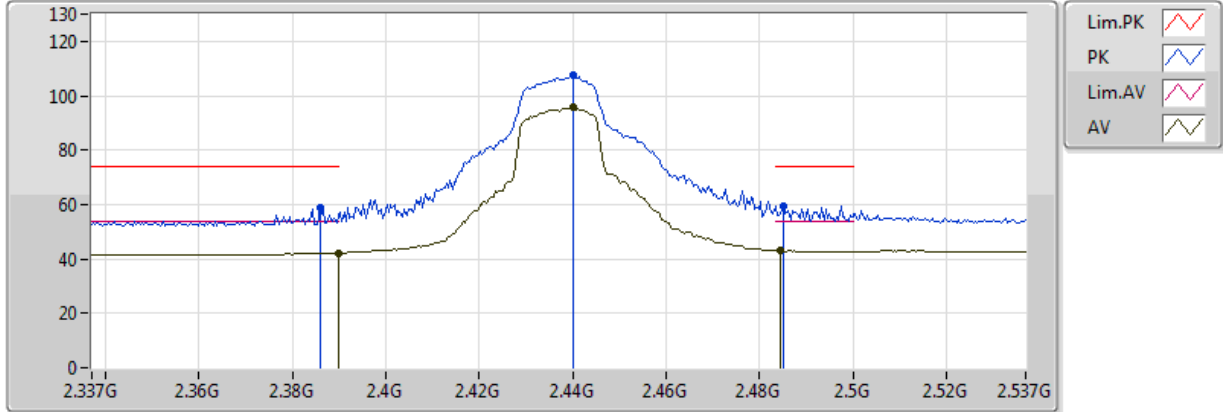

EUT = Y

Type	Freq(Hz)	Level(dBuV/m)	Limit(dBuV/m)	Margin(dB)	Factor(dB)	Dist(m)	Pol.(H/V)	Azimuth(°)	Height(m)	Comments
AV	2.389998G	42.28	54.00	-11.72	30.23	3	V	190	1.15	-
AV	2.4402G	95.55	Inf	-Inf	30.39	3	V	190	1.15	-
AV	2.4846G	43.10	54.00	-10.90	30.53	3	V	190	1.15	-
PK	2.3858G	58.71	74.00	-15.29	30.22	3	V	190	1.15	-
PK	2.4402G	107.32	Inf	-Inf	30.39	3	V	190	1.15	-
PK	2.485G	59.63	74.00	-14.37	30.53	3	V	190	1.15	-

802.11g_(6Mbps)_1TX

2437MHz_TX

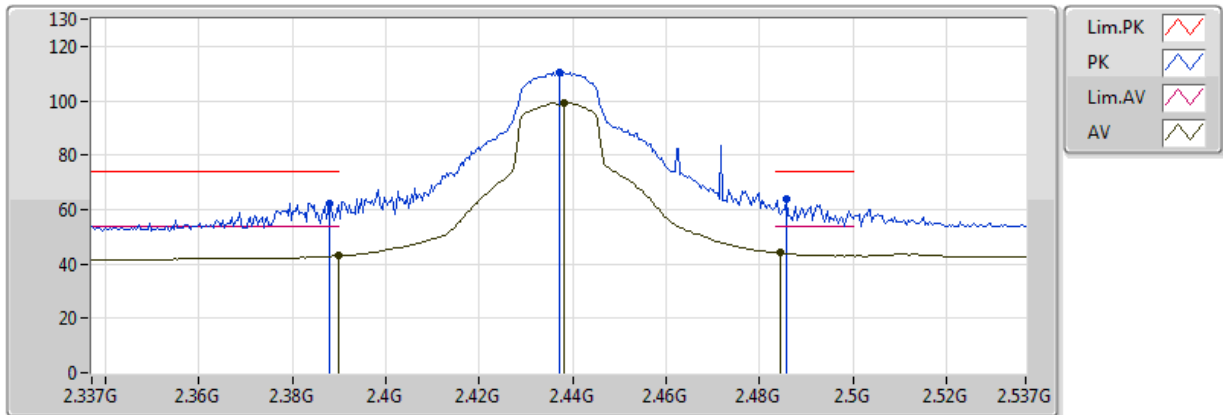

EUT = Y

Type	Freq(Hz)	Level(dBuV/m)	Limit(dBuV/m)	Margin(dB)	Factor(dB)	Dist(m)	Pol.(H/V)	Azimuth(°)	Height(m)	Comments
AV	2.4382G	99.32	Inf	-Inf	30.38	3	H	114	1.01	-
AV	2.389998G	42.96	54.00	-11.04	30.23	3	H	114	1.01	-
AV	2.4846G	44.10	54.00	-9.90	30.53	3	H	114	1.01	-
PK	2.437G	110.47	Inf	-Inf	30.38	3	H	114	1.01	-
PK	2.3878G	62.36	74.00	-11.64	30.22	3	H	114	1.01	-
PK	2.4858G	63.93	74.00	-10.07	30.53	3	H	114	1.01	-

802.11g_(6Mbps)_1TX

2437MHz_TX

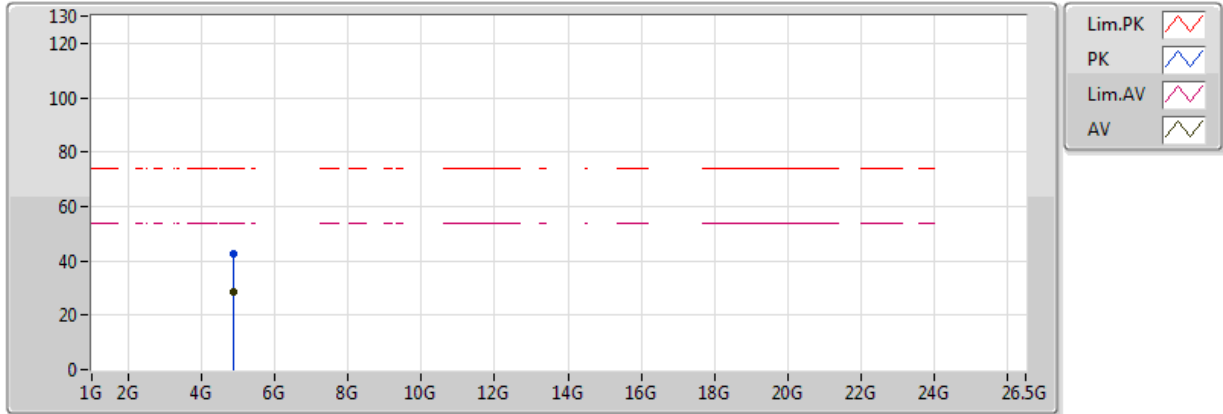

EUT = Y

Type	Freq(Hz)	Level(dBuV/m)	Limit(dBuV/m)	Margin(dB)	Factor(dB)	Dist(m)	Pol.(H/V)	Azimuth(°)	Height(m)	Comments
AV	4.874G	28.70	54.00	-25.30	1.06	3	V	360	1.50	-
PK	4.874G	42.68	74.00	-31.32	1.06	3	V	360	1.50	-

802.11g_(6Mbps)_1TX

2437MHz_TX

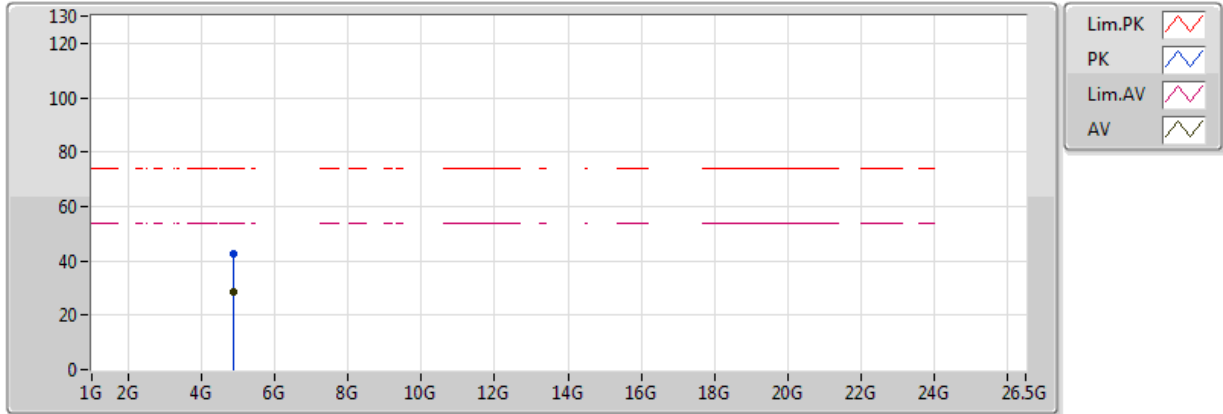

EUT = Y

Type	Freq(Hz)	Level(dBuV/m)	Limit(dBuV/m)	Margin(dB)	Factor(dB)	Dist(m)	Pol.(H/V)	Azimuth(°)	Height(m)	Comments
AV	4.874G	28.52	54.00	-25.48	1.06	3	H	0	1.50	-
PK	4.874G	42.63	74.00	-31.37	1.06	3	H	0	1.50	-

802.11g_(6Mbps)_1TX

2462MHz_TX

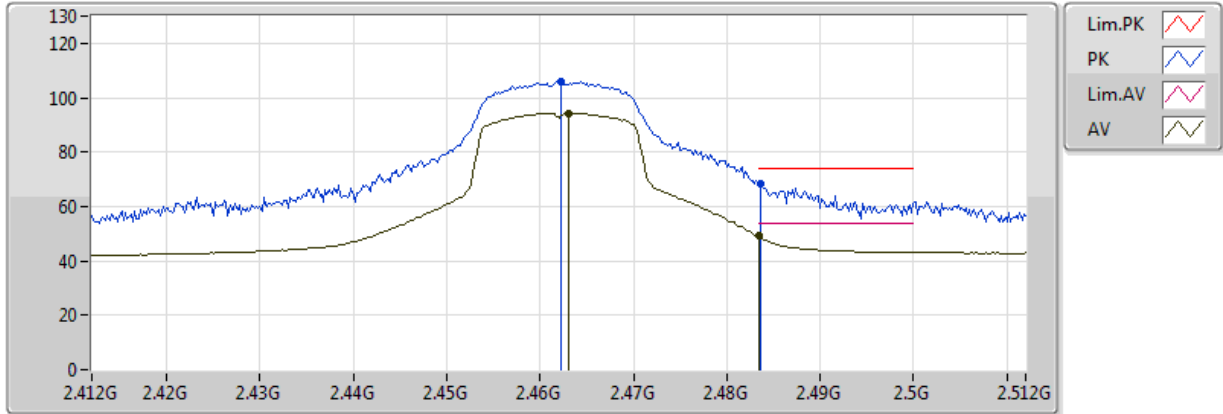

EUT = Y

Type	Freq(Hz)	Level(dBuV/m)	Limit(dBuV/m)	Margin(dB)	Factor(dB)	Dist(m)	Pol.(H/V)	Azimuth(°)	Height(m)	Comments
AV	2.463G	94.39	Inf	-Inf	30.46	3	V	187	1.39	-
AV	2.483502G	49.04	54.00	-4.96	30.53	3	V	187	1.39	-
PK	2.4622G	105.75	Inf	-Inf	30.46	3	V	187	1.39	-
PK	2.4836G	68.30	74.00	-5.70	30.53	3	V	187	1.39	-

802.11g_(6Mbps)_1TX

2462MHz_TX

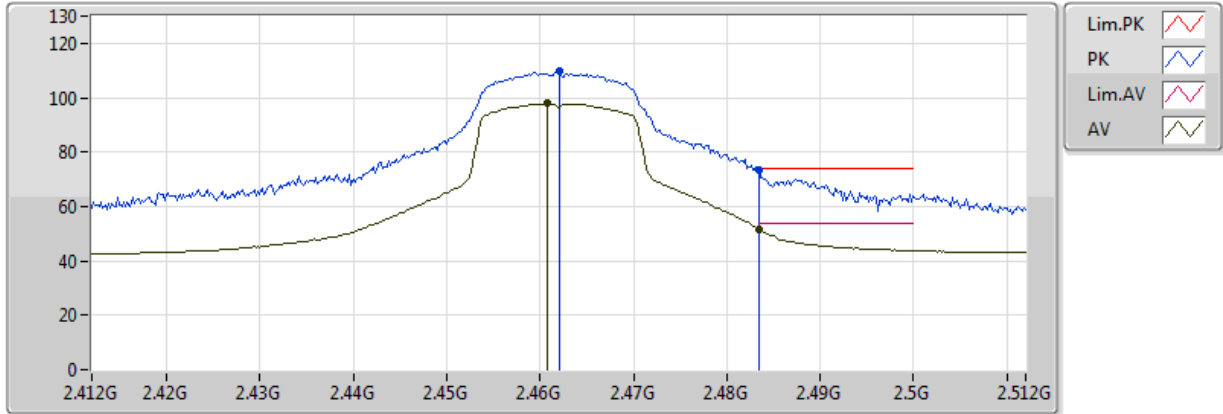

EUT = Y

Type	Freq(Hz)	Level(dBuV/m)	Limit(dBuV/m)	Margin(dB)	Factor(dB)	Dist(m)	Pol.(H/V)	Azimuth(°)	Height(m)	Comments
AV	2.4608G	97.86	Inf	-Inf	30.45	3	H	120	1.32	-
AV	2.483502G	51.67	54.00	-2.33	30.53	3	H	120	1.32	-
PK	2.462G	110.06	Inf	-Inf	30.46	3	H	120	1.32	-
PK	2.483502G	73.38	74.00	-0.62	30.53	3	H	120	1.32	-

802.11g_(6Mbps)_1TX

2462MHz_TX

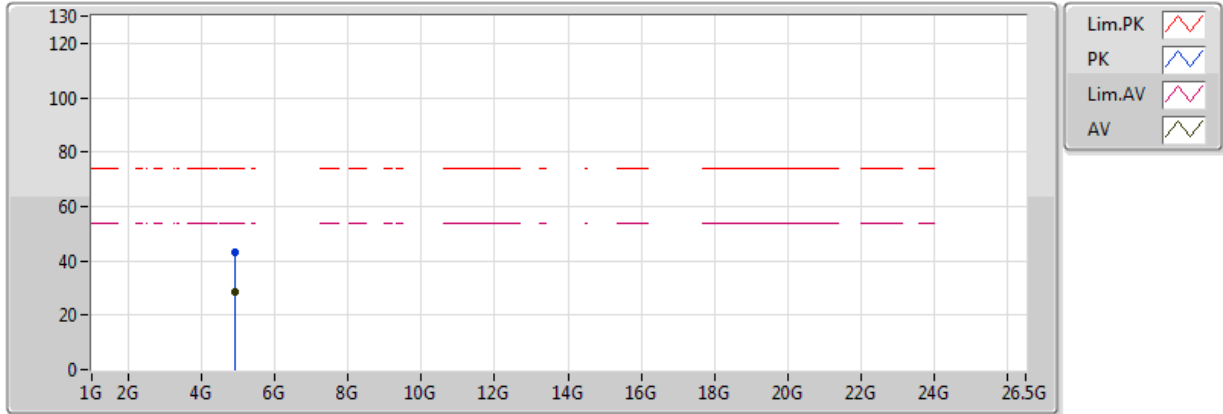

EUT = Y

Type	Freq(Hz)	Level(dBuV/m)	Limit(dBuV/m)	Margin(dB)	Factor(dB)	Dist(m)	Pol.(H/V)	Azimuth(°)	Height(m)	Comments
AV	4.924G	28.82	54.00	-25.18	1.17	3	V	0	1.50	-
PK	4.924G	43.20	74.00	-30.80	1.17	3	V	0	1.50	-

802.11g_(6Mbps)_1TX

2462MHz_TX

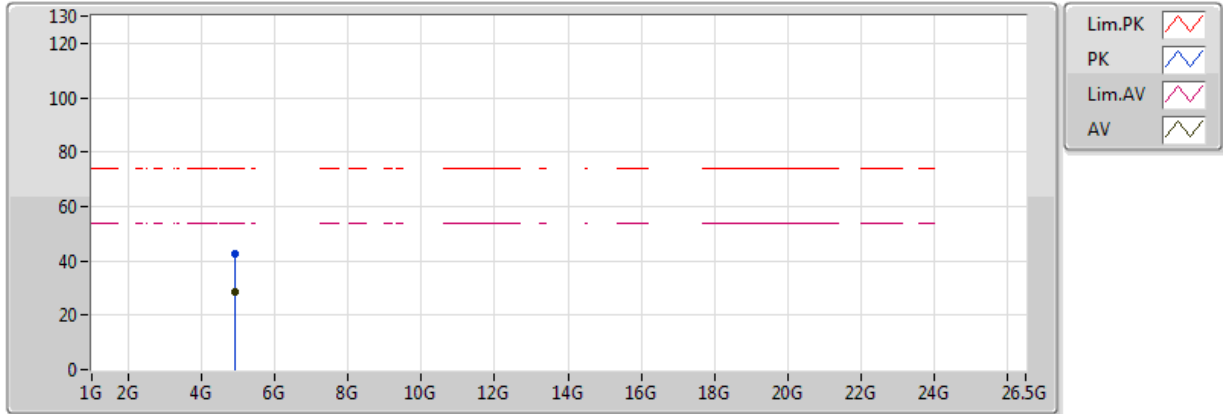

EUT = Y

Type	Freq(Hz)	Level(dBuV/m)	Limit(dBuV/m)	Margin(dB)	Factor(dB)	Dist(m)	Pol.(H/V)	Azimuth(°)	Height(m)	Comments
AV	4.924G	28.84	54.00	-25.16	1.17	3	H	360	1.50	-
PK	4.924G	42.80	74.00	-31.20	1.17	3	H	360	1.50	-