



We help ideas meet the real world

---

## Photos of Test setups

### Performed for DeLaval International AB

REC- E703806\_2 FCC photos

Project no.: E703806

Page 1 of 8

22 March 2016

**DELTA Development  
Technology AB**

Finnslätten  
Elektronikgatan 47  
721 36 Västerås  
Sweden

Tel. 021-31 44 80  
Fax 021-31 44 81  
info@delta-dt.se  
www.delta-dt.se

Bankgiro 5534-7728  
VAT SE 556556207001

DELTA Development  
Technology AB  
is a subsidiary company of  
DELTA

<b>Title</b>	Photos of Test setups
<b>Test object</b>	In Place Reader IPR
<b>Document no.</b>	REC-E703806_2 FCC photos
<b>Project no.</b>	E703806

<b>Table of contents</b>		<b>Page</b>
<b>1.</b>	<b>Test setup during test</b>	<b>3</b>
1.1	Auxiliary equipment	4
<b>2.</b>	<b>Photos of test set-up</b>	<b>5</b>
2.1	Measurement of radio frequency voltage on mains	5
2.2	Measurement of spurious emission 0.09 – 30 MHz	6
2.3	Measurement of spurious emission 30 – 1000 MHz	8

## 1. Test setup during test

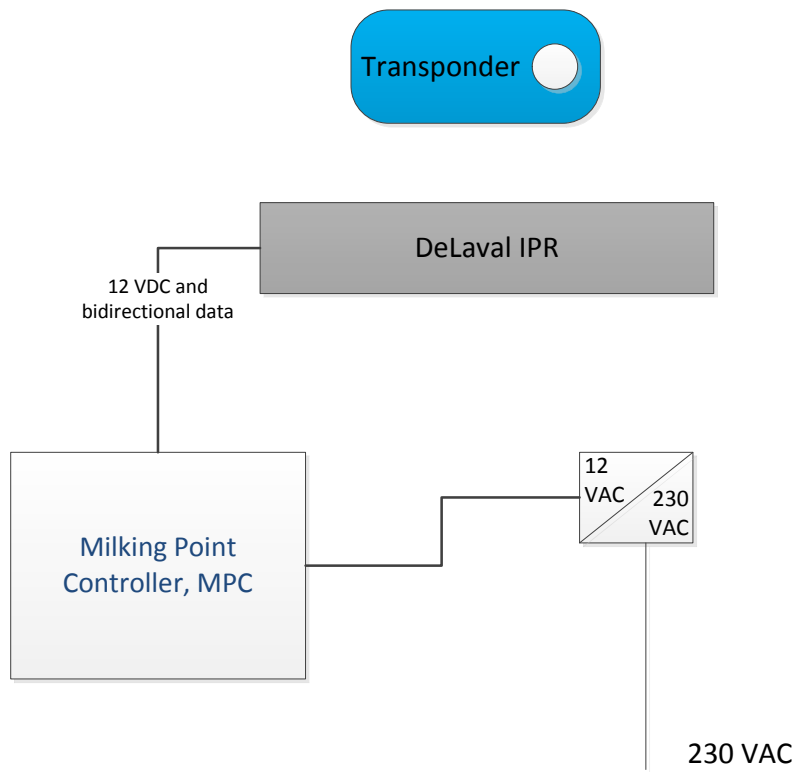

Figure 1.1 Block diagram of test object(s) with cables and auxiliary equipment.

## 1.1 Auxiliary equipment

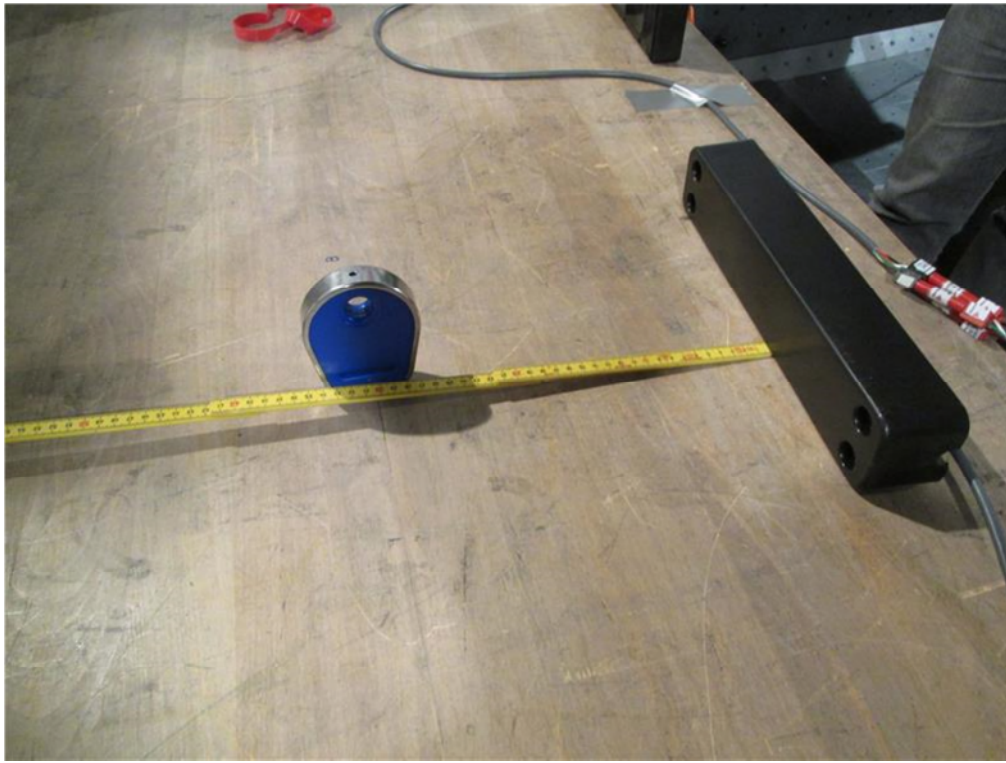

Photo 1.1.1 Auxiliary equipment. DeLaval transponder (left)

## 2. Photos of test set-up

### 2.1 Measurement of radio frequency voltage on mains



Photo 2.1.1 Test setup regarding measurement of radio frequency voltage on mains.



Photo 2.1.2 Test setup regarding measurement of radio frequency voltage on mains.





## 2.2 Measurement of spurious emission 0.09 – 30 MHz



Photo 2.2.1 Test setup regarding measurement of radio frequency electromagnetic field. Preview measurement in shielded room



Photo 2.2.2 Test setup regarding measurement of radio frequency electromagnetic field. Preview measurement in shielded room





Photo 2.2.3 Test setup regarding measurement of radio frequency electromagnetic field. Verification measurement outdoors. 30 m measurement distance.



Photo 2.2.4 Test setup regarding measurement of radio frequency electromagnetic field. Verification measurement outdoors. 30 m measurement distance.





### 2.3 Measurement of spurious emission 30 – 1000 MHz



Photo 2.3.1 Test setup regarding measurement of radio frequency electromagnetic field.



Photo 2.3.1 Test setup regarding measurement of radio frequency electromagnetic field.

