



FCC RF Test Report

APPLICANT : Panasonic Mobile Communications
Development of Europe Ltd

EQUIPMENT : Mobile Phone

BRAND NAME : NTT docomo

MODEL NAME : Panasonic EB-4070

MARKETING NAME : P-01J

FCC ID : UCE216065A

STANDARD : FCC Part 15 Subpart C §15.247

CLASSIFICATION : (DTS) Digital Transmission System

The product was received on Jul. 13, 2016 and testing was completed on Aug. 12, 2016. We, SPORTON INTERNATIONAL INC., would like to declare that the tested sample has been evaluated in accordance with the test procedures and has been in compliance with the applicable technical standards.

The test results in this report apply exclusively to the tested model / sample. Without written approval of SPORTON INTERNATIONAL INC., the test report shall not be reproduced except in full.

Reviewed by: Joseph Lin / Supervisor

Approved by: Jones Tsai / Manager



SPORTON INTERNATIONAL INC.

No. 52, Hwa Ya 1st Rd., Hwa Ya Technology Park, Kwei-Shan District, Tao Yuan City, Taiwan, R.O.C.



TABLE OF CONTENTS

REVISION HISTORY..... 3

SUMMARY OF TEST RESULT 4

1 GENERAL DESCRIPTION 5

 1.1 Applicant 5

 1.2 Manufacturer 5

 1.3 Product Feature of Equipment Under Test..... 5

 1.4 Product Specification of Equipment Under Test..... 6

 1.5 Modification of EUT 6

 1.6 Testing Location 7

 1.7 Applicable Standards..... 7

2 TEST CONFIGURATION OF EQUIPMENT UNDER TEST 8

 2.1 Carrier Frequency Channel 8

 2.2 Test Mode 9

 2.3 Connection Diagram of Test System 11

 2.4 Support Unit used in test configuration and system 12

 2.5 EUT Operation Test Setup 12

 2.6 Measurement Results Explanation Example..... 12

3 TEST RESULT 13

 3.1 6dB and 99% Bandwidth Measurement 13

 3.2 Output Power Measurement..... 15

 3.3 Power Spectral Density Measurement 17

 3.4 Conducted Band Edges and Spurious Emission Measurement 19

 3.5 Radiated Band Edges and Spurious Emission Measurement 29

 3.6 AC Conducted Emission Measurement..... 33

 3.7 Antenna Requirements 39

4 LIST OF MEASURING EQUIPMENT 40

5 UNCERTAINTY OF EVALUATION 41

APPENDIX A. CONDUCTED TEST RESULTS

APPENDIX B. RADIATED SPURIOUS EMISSION

APPENDIX C. RADIATED SPURIOUS EMISSION PLOTS

APPENDIX D. DUTY CYCLE PLOTS

**SUMMARY OF TEST RESULT**

Report Section	FCC Rule	Description	Limit	Result	Remark
3.1	15.247(a)(2)	6dB Bandwidth	$\geq 0.5\text{MHz}$	Pass	-
3.1	-	99% Bandwidth	-	Pass	-
3.2	15.247(b)	Power Output Measurement	$\leq 30\text{dBm}$	Pass	-
3.3	15.247(e)	Power Spectral Density	$\leq 8\text{dBm}/3\text{kHz}$	Pass	-
3.4	15.247(d)	Conducted Band Edges	$\leq 20\text{dBc}$	Pass	-
		Conducted Spurious Emission		Pass	-
3.5	15.247(d)	Radiated Band Edges and Radiated Spurious Emission	15.209(a) & 15.247(d)	Pass	Under limit 0.46 dB at 2390.000 MHz
3.6	15.207	AC Conducted Emission	15.207(a)	Pass	Under limit 5.70 dB at 0.470 MHz
3.7	15.203 & 15.247(b)	Antenna Requirement	N/A	Pass	-



1 General Description

1.1 Applicant

Panasonic Mobile Communications Development of Europe Ltd
Willoughby Road, Bracknell, Berkshire RG12 8FP, UK

1.2 Manufacturer

Panasonic Mobile Communications Development of Europe Ltd
Willoughby Road, Bracknell, Berkshire RG12 8FP, UK

1.3 Product Feature of Equipment Under Test

Product Feature	
Equipment	Mobile Phone
Brand Name	NTT docomo
Model Name	Panasonic EB-4070
Marketing Name	P-01J
FCC ID	UCE216065A
EUT supports Radios application	WCDMA/HSPA/LTE/NFC WLAN 11b/g/n HT20 Bluetooth v4.1 BR/EDR/LE
HW Version	Rev C
SW Version	ACPU: amethyst-lp-12-0088, CCPU: AMET.1200C1100034.1013.00
EUT Stage	Production Unit

Remark: The above EUT's information was declared by manufacturer. Please refer to the specifications or user's manual for more detailed description.

Specification of Accessory		
AC Adapter	Brand Name	NTT docomo
	Model Name	AC Adaptor 04
Battery	Brand Name	Sanyo
	Model Name	P33
Earphone	Brand Name	NTT docomo
	Model Name	Stereo Earphone Type 02
USB Cable	Brand Name	NTT docomo
	Model Name	Micro USB Cable Type 01



1.4 Product Specification of Equipment Under Test

Standards-related Product Specification	
Tx/Rx Channel Frequency Range	802.11b/g/n : 2412 MHz ~ 2462 MHz
Maximum (Peak) Output Power to Antenna	802.11b : 14.89 dBm (0.0308 W) 802.11g : 21.22 dBm (0.1324 W) 802.11n HT20 : 21.34 dBm (0.1361 W)
99% Occupied Bandwidth	802.11b : 13.49MHz 802.11g : 18.63MHz 802.11n HT20 : 19.48MHz
Antenna Type	Monopole Antenna type with gain 1.50 dBi
Type of Modulation	802.11b : DSSS (DBPSK / DQPSK / CCK) 802.11a/g/n : OFDM (BPSK / QPSK / 16QAM / 64QAM)

1.5 Modification of EUT

No modifications are made to the EUT during all test items.



1.6 Testing Location

Sporton Lab is accredited to ISO 17025 by Taiwan Accreditation Foundation (TAF code : 1190) and the FCC designation No. TW1022 under the FCC 2.948(e) by Mutual Recognition Agreement (MRA) in FCC Test.

Test Site	SPORTON INTERNATIONAL INC.		
Test Site Location	No. 52, Hwa Ya 1 st Rd., Hwa Ya Technology Park, Kwei-Shan District, Tao Yuan City, Taiwan, R.O.C. TEL: +886-3-327-3456 FAX: +886-3-328-4978		
Test Site No.	Sporton Site No.		
	TH02-HY	CO05-HY	03CH07-HY

Note: The test site complies with ANSI C63.4 2014 requirement.

1.7 Applicable Standards

According to the specifications of the manufacturer, the EUT must comply with the requirements of the following standards:

- ♦ FCC Part 15 Subpart C §15.247
- ♦ FCC KDB Publication No. 558074 D01 DTS Meas. Guidance v03r05
- ♦ ANSI C63.10-2013

Remark:

1. All test items were verified and recorded according to the standards and without any deviation during the test.
2. This EUT has also been tested and complied with the requirements of FCC Part 15, Subpart B, recorded in a separate test report.



2 Test Configuration of Equipment Under Test

The EUT has been associated with peripherals and configuration operated in a manner tended to maximize its emission characteristics in a typical application. Frequency range investigated: conducted emission (150 kHz to 30 MHz) and radiated emission (9 kHz to the 10th harmonic of the highest fundamental frequency or to 40 GHz, whichever is lower). For radiated measurement, pre-scanned in three orthogonal panels, X, Y, Z. The worst cases (Y plane) were recorded in this report.

2.1 Carrier Frequency Channel

Frequency Band	Channel	Freq. (MHz)	Channel	Freq. (MHz)
2400-2483.5 MHz	1	2412	7	2442
	2	2417	8	2447
	3	2422	9	2452
	4	2427	10	2457
	5	2432	11	2462
	6	2437	-	-



2.2 Pre-Scanned RF Power

Preliminary tests were performed in different data rate and data rate associated with the highest power were chosen for full test shown in the following tables.

2.4GHz 802.11b mode				
Data Rate (MHz)	1M bps	2M bps	5.5M bps	11M bps
Peak Power (dBm)	14.89	14.60	14.50	14.60

2.4GHz 802.11g mode								
Data Rate (MHz)	6M bps	9M bps	12M bps	18M bps	24M bps	36M bps	48M bps	54M bps
Peak Power (dBm)	21.22	21.10	21.20	21.11	21.17	21.16	21.20	21.19

2.4GHz 802.11n HT20 mode								
Data Rate (MHz)	MCS0	MCS1	MCS2	MCS3	MCS4	MCS5	MCS6	MCS7
Peak Power (dBm)	21.34	21.26	21.20	21.30	21.27	21.28	21.25	21.30



2.3 Test Mode

Final test mode of conducted test items and radiated spurious emissions are considering the modulation and worse data rates as below table.

<2.4GHz>

Modulation	Data Rate
802.11b	1 Mbps
802.11g	6 Mbps
802.11n HT20	MCS0

Test Cases	
AC Conducted Emission	Mode 1 : Bluetooth Link + WLAN Link + SD Card + MPEG4 + USB Cable (Data Link with Notebook)

2.4 Connection Diagram of Test System

<WLAN Tx Mode>

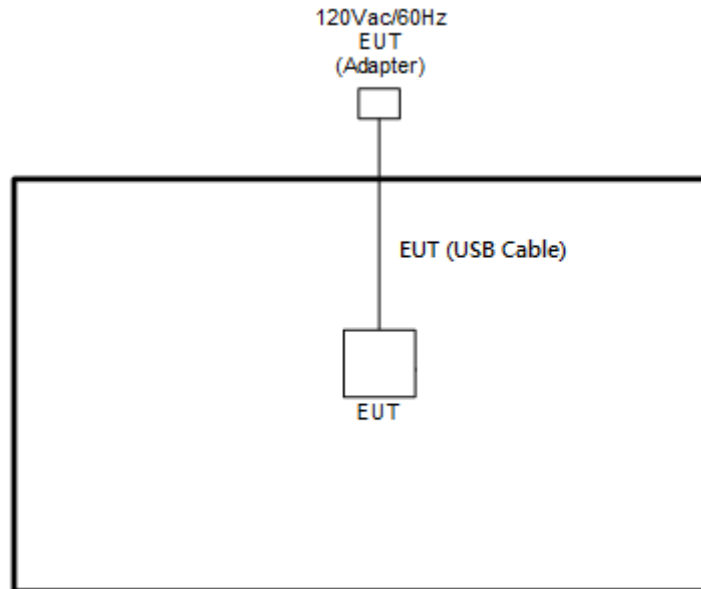

<AC Conducted Emission Mode>

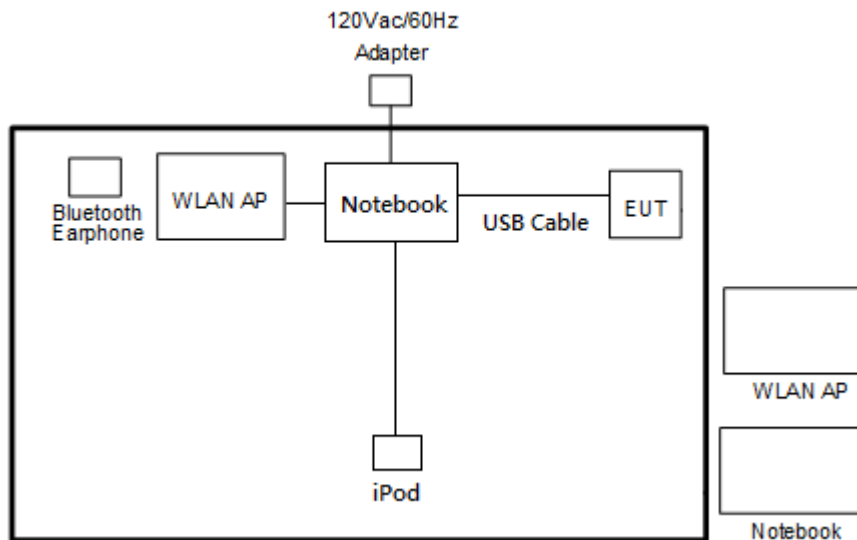



2.5 Support Unit used in test configuration and system

Item	Equipment	Trade Name	Model Name	FCC ID	Data Cable	Power Cord
1.	WLAN AP	D-Link	DIR-628	KA2DIR628A2	N/A	Unshielded, 1.8 m
2.	Notebook	DELL	P20G	FCC DoC	N/A	AC I/P: Unshielded, 1.2 m DC O/P: Shielded, 1.8 m
3.	Notebook	DELL	Latitude E6320	FCC DoC/ Contains FCC ID: QDS-BRCM1054	N/A	AC I/P: Unshielded, 1.2 m DC O/P: Shielded, 1.8 m
4.	Bluetooth Earphone	Sony Ericsson	MW600	PY7DDA-2029	N/A	N/A
5.	SD Card	SanDisk	MicroSD HC	FCC DoC	N/A	N/A
6.	iPod	Apple	A1285	FCC DoC	Shielded, 1.0 m	N/A

2.6 EUT Operation Test Setup

For WLAN function, programmed RF utility, “QRCT” installed in the notebook make the EUT provide functions like channel selection and power level for continuous transmitting and receiving signals.

2.7 Measurement Results Explanation Example

For all conducted test items:

The offset level is set in the spectrum analyzer to compensate the RF cable loss and attenuator factor between EUT conducted output port and spectrum analyzer. With the offset compensation, the spectrum analyzer reading level is exactly the EUT RF output level.

Example :

The spectrum analyzer offset is derived from RF cable loss and attenuator factor.

Offset = RF cable loss + attenuator factor.

Following shows an offset computation example with cable loss 4.2 dB and 10dB attenuator.

$$\begin{aligned} \text{Offset(dB)} &= \text{RF cable loss(dB)} + \text{attenuator factor(dB)}. \\ &= 4.2 + 10 = 14.2 \text{ (dB)} \end{aligned}$$

3 Test Result

3.1 6dB and 99% Bandwidth Measurement

3.1.1 Limit of 6dB and 99% Bandwidth

The minimum 6 dB bandwidth shall be at least 500 kHz.

3.1.2 Measuring Instruments

The measuring equipment is listed in the section 4 of this test report.

3.1.3 Test Procedures

1. The testing follows FCC KDB Publication No. 558074 DTS D01 Meas. Guidance v03r05.
2. The RF output of EUT was connected to the spectrum analyzer by RF cable and attenuator. The path loss was compensated to the results for each measurement.
3. Set to the maximum power setting and enable the EUT transmit continuously.
4. Make the measurement with the spectrum analyzer's resolution bandwidth (RBW) = 100 kHz. Set the Video bandwidth (VBW) = 300 kHz. In order to make an accurate measurement. The 6 dB bandwidth must be greater than 500 kHz.
5. For 99% Bandwidth Measurement, the spectrum analyzer's resolution bandwidth (RBW) = 1MHz and set the Video bandwidth (VBW) = 3MHz.
6. Measure and record the results in the test report.

3.1.4 Test Setup





3.1.5 Test Result of 6dB and 99% Occupied Bandwidth

Please refer to Appendix A of this test report.

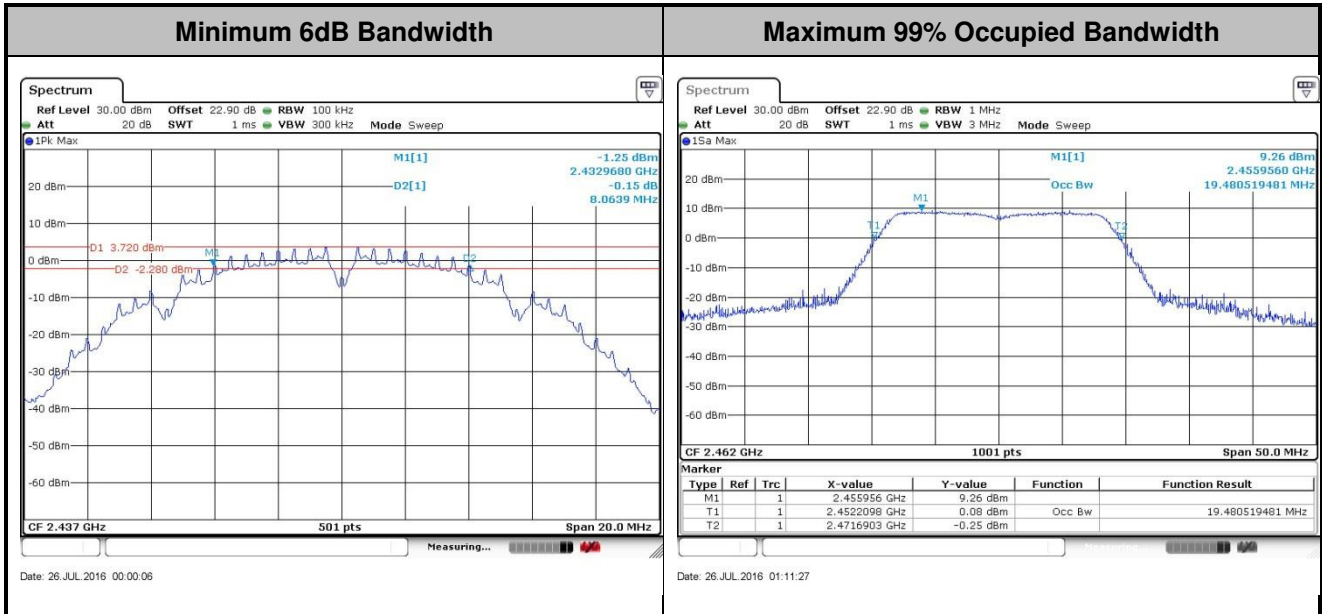

Note: The occupied channel bandwidth is maintained within the band of operation for all of the modulations.

3.2 Output Power Measurement

3.2.1 Limit of Output Power

For systems using digital modulation in the 2400-2483.5MHz, the limit for peak output power is 30dBm. If transmitting Antenna of directional gain greater than 6dBi are used the peak output power from the intentional radiator shall be reduced below the above stated value by the amount in dB that the directional gain of the Antenna exceeds 6 dBi. In case of point-to-point operation, the limit has to be reduced by 1dB for every 3dB that the directional gain of the Antenna exceeds 6dBi.

3.2.2 Measuring Instruments

The measuring equipment is listed in the section 4 of this test report.

3.2.3 Test Procedures

1. The testing follows the Measurement Procedure of FCC KDB No. 558074 DTS D01 Meas. Guidance v03r05 section 9.1.2 PKPM1 Peak power meter method.
2. The RF output of EUT was connected to the power meter by RF cable and attenuator. The path loss was compensated to the results for each measurement.
3. Set to the maximum power setting and enable the EUT transmit continuously.
4. Measure the conducted output power and record the results in the test report.

3.2.4 Test Setup

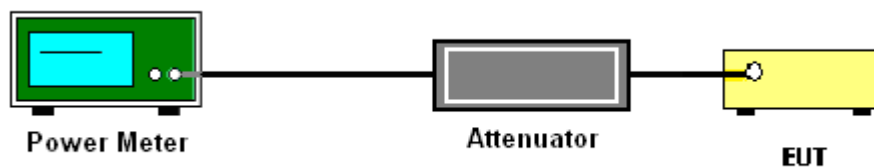



3.2.5 Test Result of Peak Output Power

Please refer to Appendix A of this test report.

3.2.6 Test Result of Average output Power (Reporting Only)

Please refer to Appendix A of this test report.

3.3 Power Spectral Density Measurement

3.3.1 Limit of Power Spectral Density

The peak power spectral density shall not be greater than 8dBm in any 3kHz band at any time interval of continuous transmission.

3.3.2 Measuring Instruments

The measuring equipment is listed in the section 4 of this test report.

3.3.3 Test Procedures

1. The testing follows Measurement Procedure 10.2 Method PKPSD of FCC KDB Publication No. 558074 D01 DTS Meas. Guidance v03r05
2. The RF output of EUT was connected to the spectrum analyzer by RF cable and attenuator. The path loss was compensated to the results for each measurement.
3. Set to the maximum power setting and enable the EUT transmit continuously.
4. Make the measurement with the spectrum analyzer's resolution bandwidth (RBW) = 3 kHz. Video bandwidth VBW = 10 kHz In order to make an accurate measurement, set the span to 1.5 times DTS Channel Bandwidth. (6dB BW)
5. Detector = peak, Sweep time = auto couple, Trace mode = max hold, Allow trace to fully stabilize. Use the peak marker function to determine the maximum power level.
6. Measure and record the results in the test report.

3.3.4 Test Setup

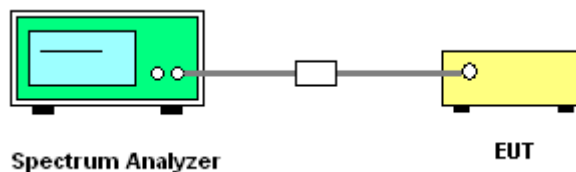



3.3.5 Test Result of Power Spectral Density

Please refer to Appendix A of this test report.

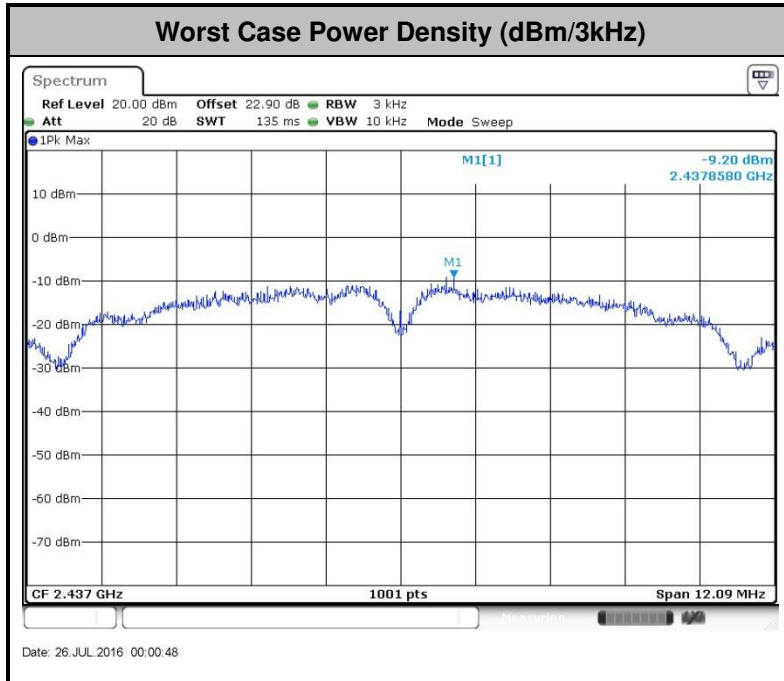

3.4 Conducted Band Edges and Spurious Emission Measurement

3.4.1 Limit of Conducted Band Edges and Spurious Emission Measurement

In any 100 kHz bandwidth outside of the authorized frequency band, the emissions which fall in the non-restricted bands shall be attenuated at least 20 dB / 30dB relative to the maximum PSD level in 100 kHz by RF conducted measurement and radiated emissions which fall in the restricted bands, as defined in Section 15.205(a), must also comply with the radiated emission limits specified in Section 15.209(a).

3.4.2 Measuring Instruments

The measuring equipment is listed in the section 4 of this test report.

3.4.3 Test Procedures

1. The testing follows FCC KDB Publication No. 558074 D01 DTS Meas. Guidance v03r05.
2. The RF output of EUT was connected to the spectrum analyzer by RF cable and attenuator. The path loss was compensated to the results for each measurement.
3. Set to the maximum power setting and enable the EUT transmit continuously.
4. Set RBW = 100 kHz, VBW=300 kHz, Peak Detector. Unwanted Emissions measured in any 100 kHz bandwidth outside of the authorized frequency band shall be attenuated by at least 20 dB relative to the maximum in-band peak PSD level in 100 kHz when maximum peak conducted output power procedure is used. If the transmitter complies with the conducted power limits based on the use of RMS averaging over a time interval, the attenuation required under this paragraph shall be 30 dB instead of 20 dB per 15.247(d).
5. Measure and record the results in the test report.
6. The RF fundamental frequency should be excluded against the limit line in the operating frequency band.

3.4.4 Test Setup

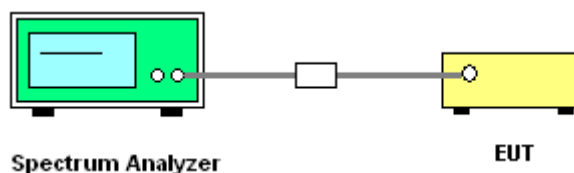



3.4.5 Test Result of Conducted Band Edges and Spurious Emission

Test Mode :	802.11b	Temperature :	21~25°C
Test Band :	2.4GHz Low	Relative Humidity :	51~54%
Test Channel :	01	Test Engineer :	Aking Chang

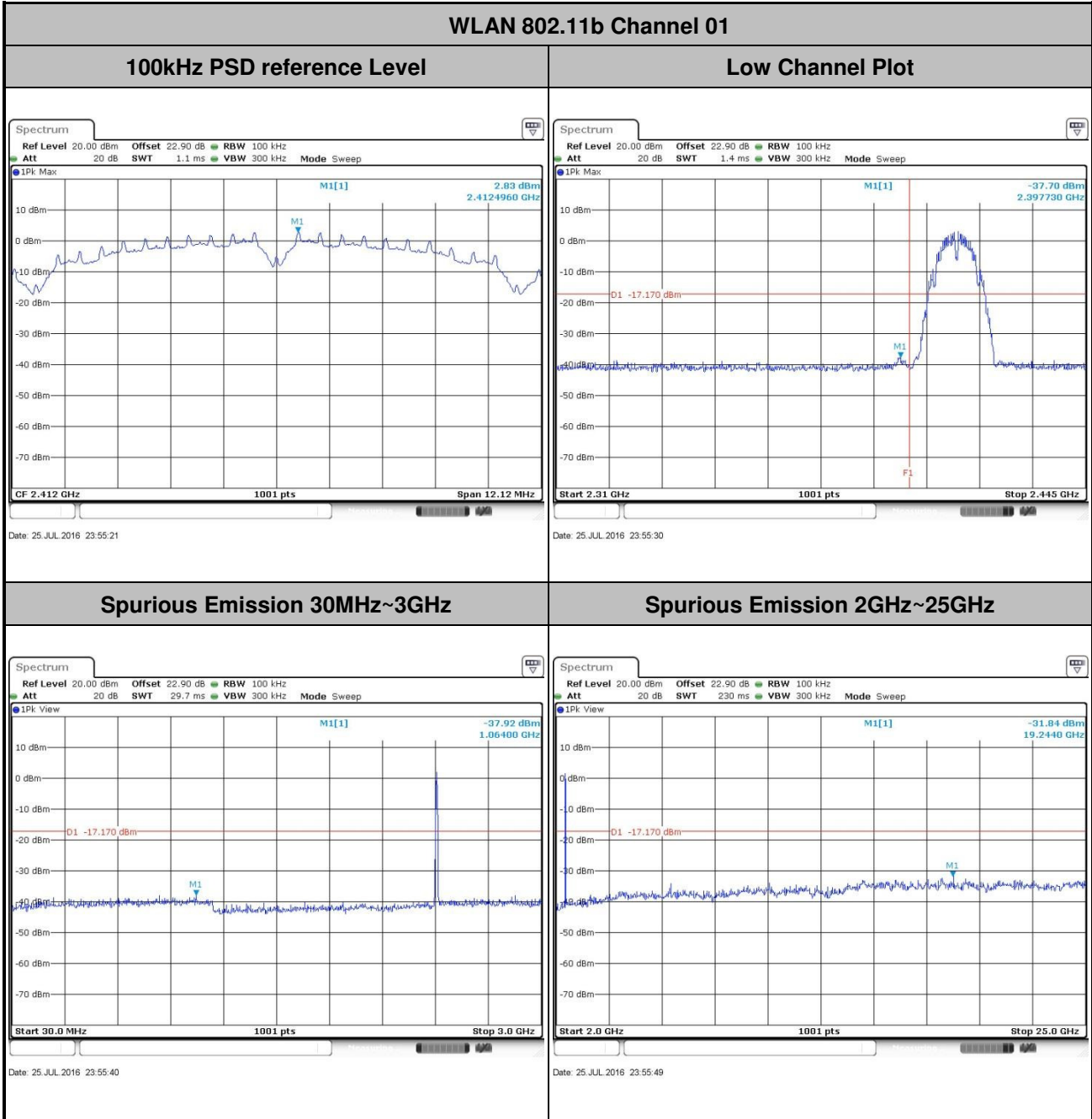



Test Mode :	802.11b	Temperature :	21~25°C
Test Band :	2.4GHz Mid	Relative Humidity :	51~54%
Test Channel :	06	Test Engineer :	Aking Chang

WLAN 802.11b Channel 06

100kHz PSD reference Level

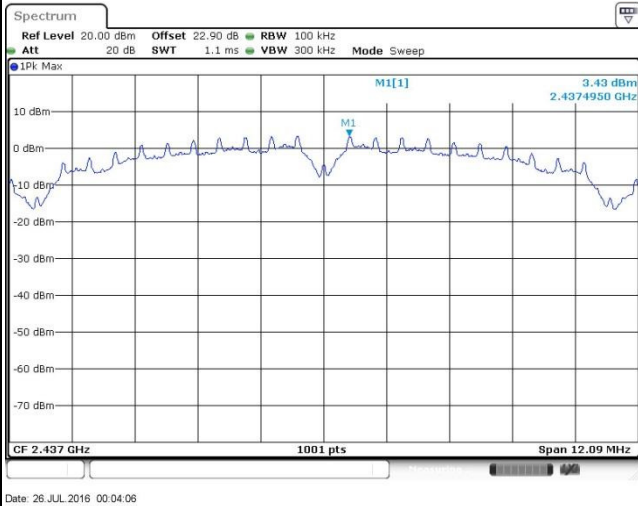

Spurious Emission 30MHz~3GHz

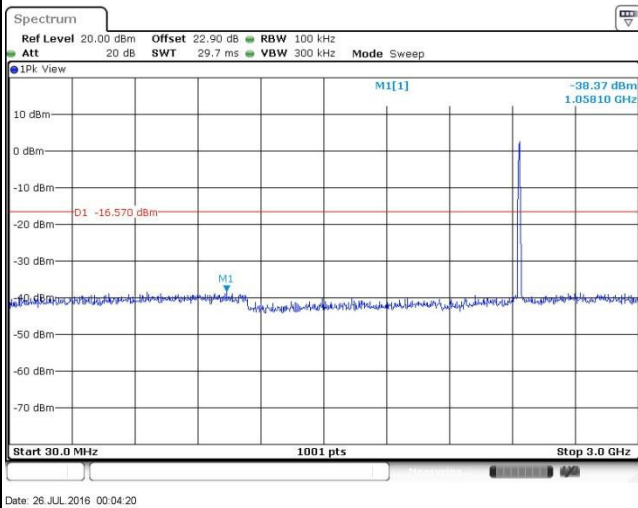

Spurious Emission 2GHz~25GHz

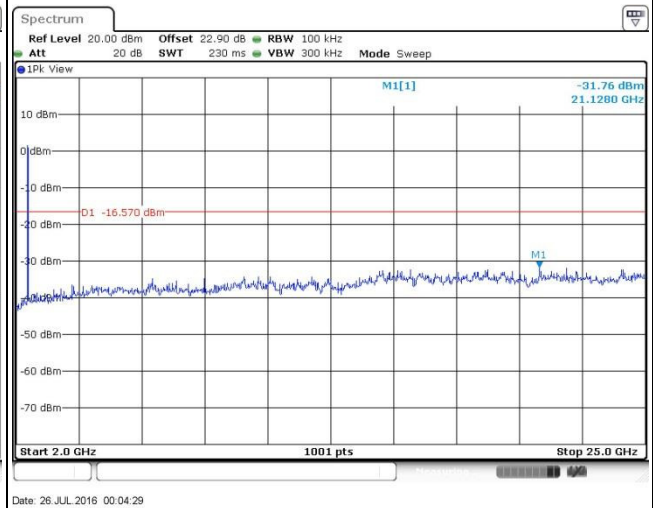



Test Mode :	802.11b	Temperature :	21~25°C
Test Band :	2.4GHz High	Relative Humidity :	51~54%
Test Channel :	11	Test Engineer :	Aking Chang

WLAN 802.11b Channel 11

100kHz PSD reference Level

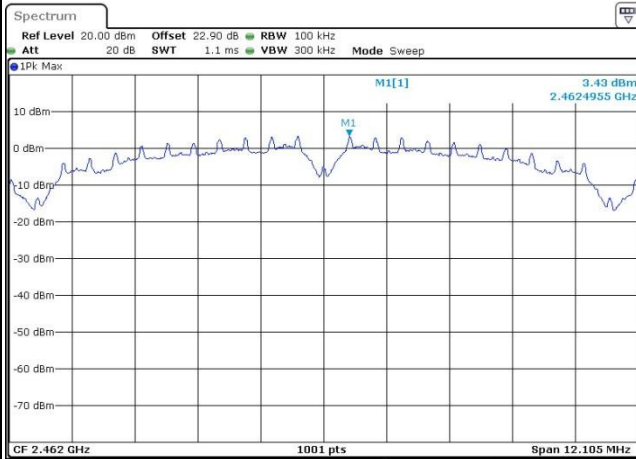

Date: 26 JUL 2016 00:12:59

High Channel Plot

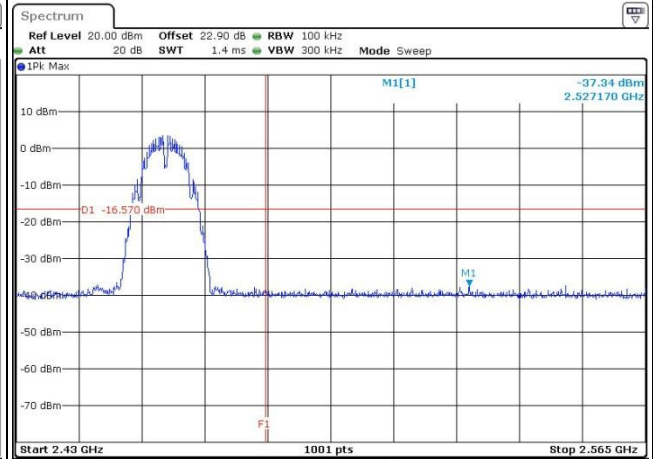

Date: 26 JUL 2016 00:13:29

Spurious Emission 30MHz~3GHz

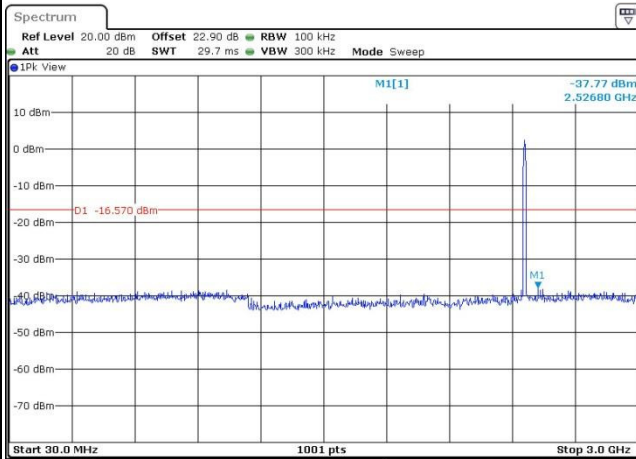

Date: 26 JUL 2016 00:13:44

Spurious Emission 2GHz~25GHz

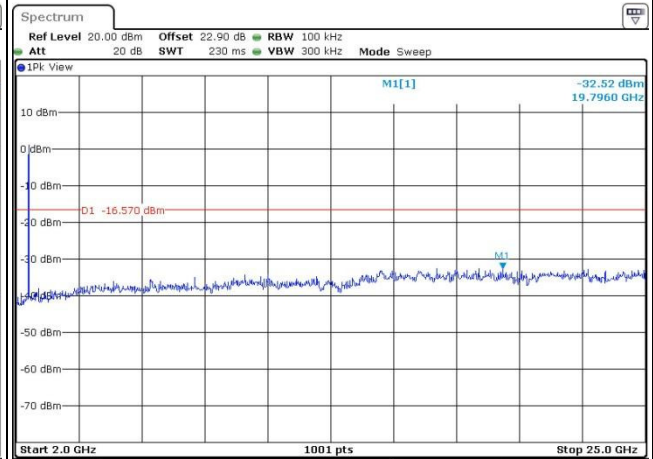

Date: 26 JUL 2016 00:13:52



Test Mode :	802.11g	Temperature :	21~25°C
Test Band :	2.4GHz Low	Relative Humidity :	51~54%
Test Channel :	01	Test Engineer :	Aking Chang

WLAN 802.11g Channel 01

100kHz PSD reference Level

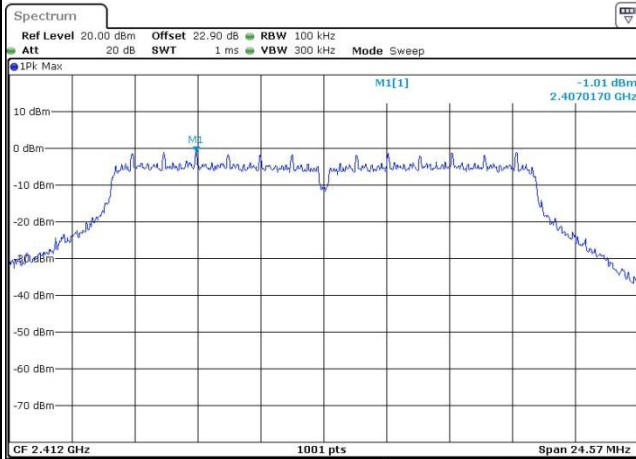

Date: 26 JUL 2016 00:29:24

Low Channel Plot

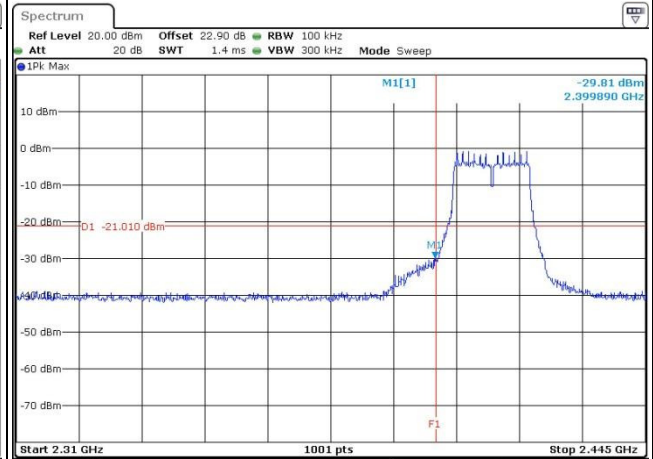

Date: 26 JUL 2016 00:31:43

Spurious Emission 30MHz~3GHz

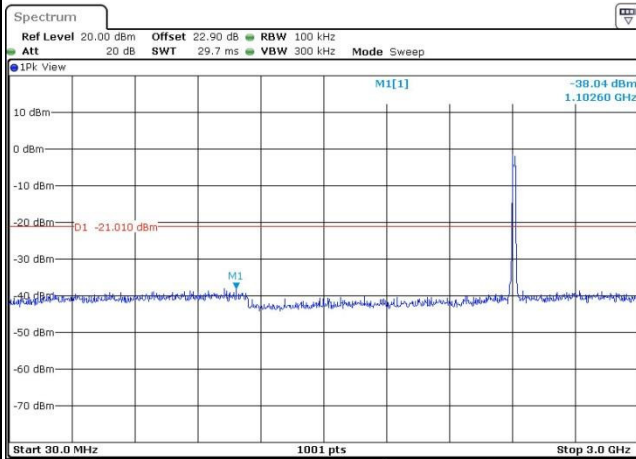

Date: 26 JUL 2016 00:32:17

Spurious Emission 2GHz~25GHz

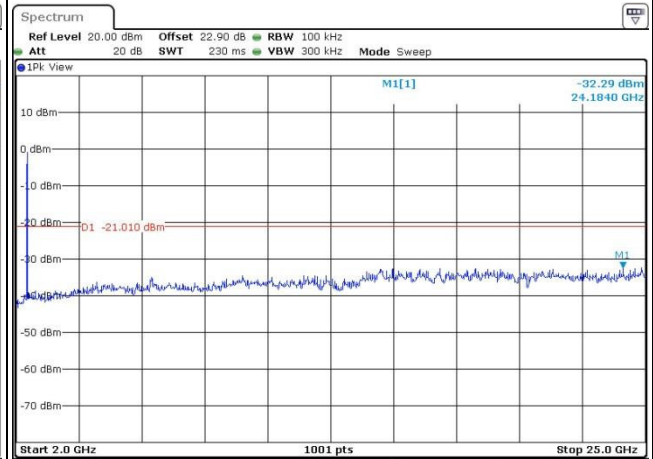

Date: 26 JUL 2016 00:32:25



Test Mode :	802.11g	Temperature :	21~25°C
Test Band :	2.4GHz Mid	Relative Humidity :	51~54%
Test Channel :	06	Test Engineer :	Aking Chang

WLAN 802.11g Channel 06

100kHz PSD reference Level

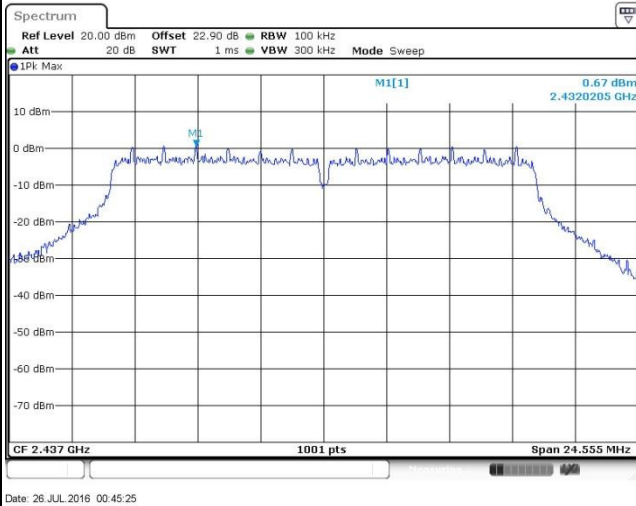

Spurious Emission 30MHz~3GHz

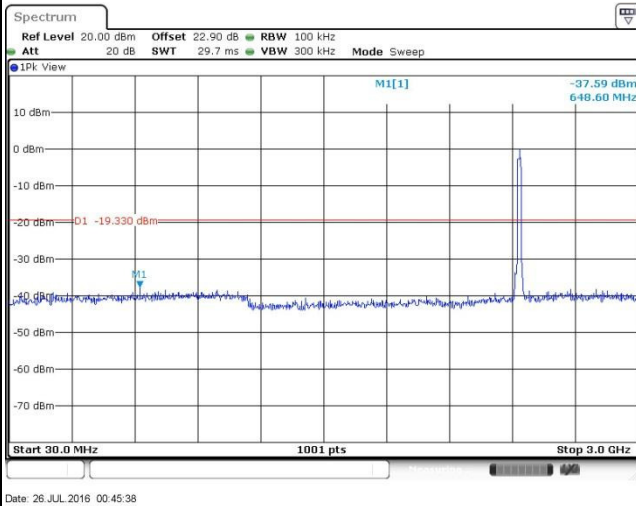

Spurious Emission 2GHz~25GHz

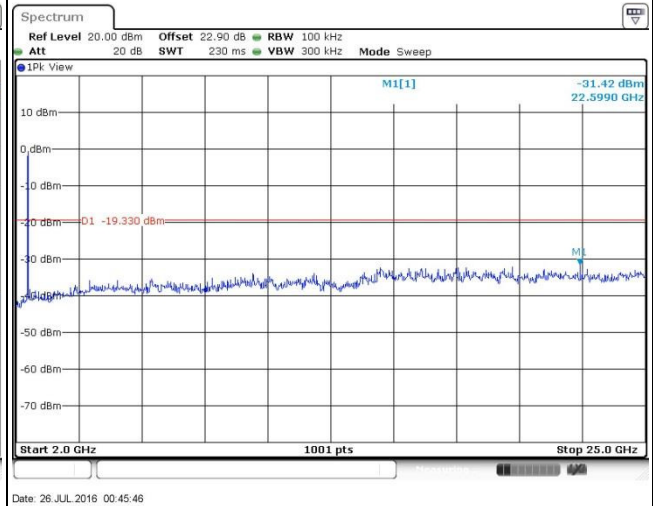



Test Mode :	802.11g	Temperature :	21~25°C
Test Band :	2.4GHz High	Relative Humidity :	51~54%
Test Channel :	11	Test Engineer :	Aking Chang

WLAN 802.11g Channel 11

100kHz PSD reference Level

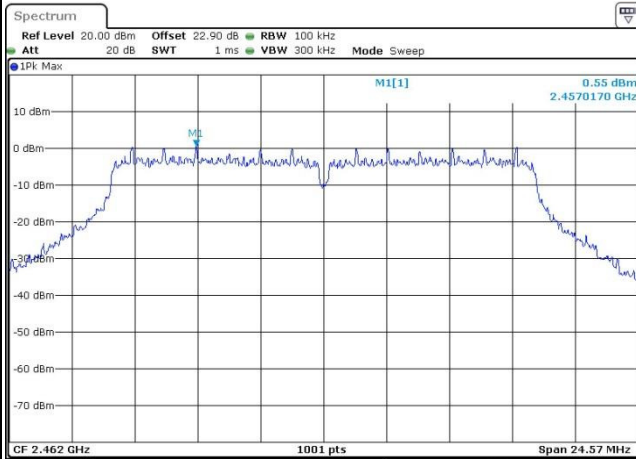

Date: 26 JUL 2016 00:50:12

High Channel Plot

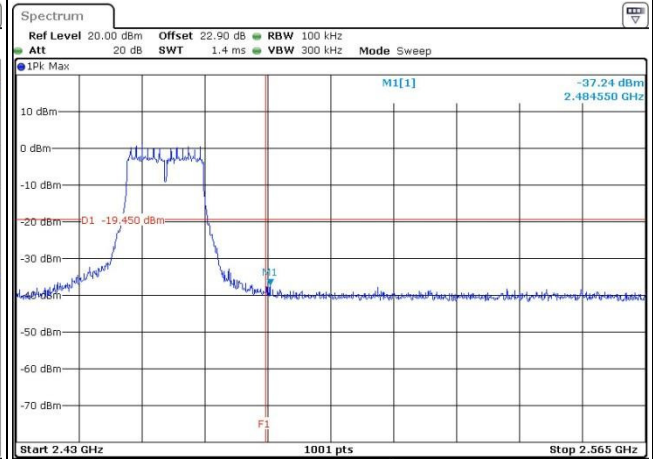

Date: 26 JUL 2016 00:50:31

Spurious Emission 30MHz~3GHz

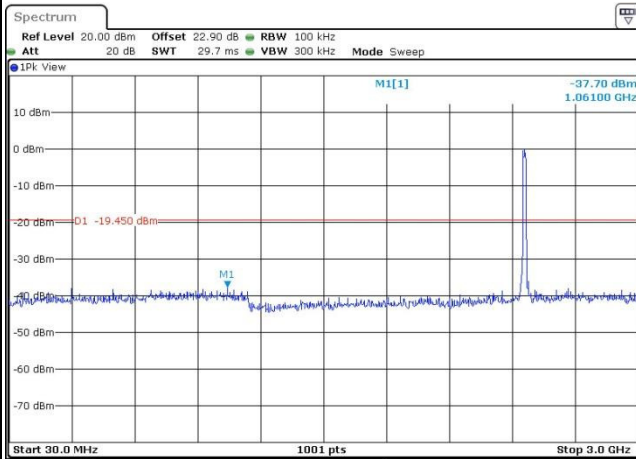

Date: 26 JUL 2016 00:51:19

Spurious Emission 2GHz~25GHz

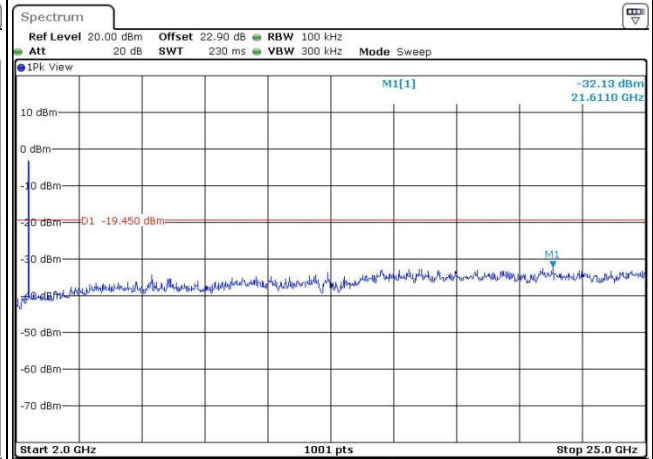

Date: 26 JUL 2016 00:51:28



Test Mode :	802.11n HT20	Temperature :	21~25°C
Test Band :	2.4GHz Low	Relative Humidity :	51~54%
Test Channel :	01	Test Engineer :	Aking Chang

WLAN 802.11n HT20 Channel 01

100kHz PSD reference Level

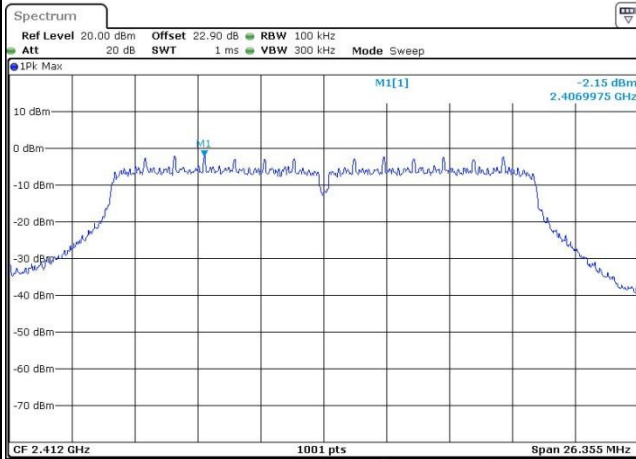

Date: 26 JUL 2016 00:57:22

Low Channel Plot

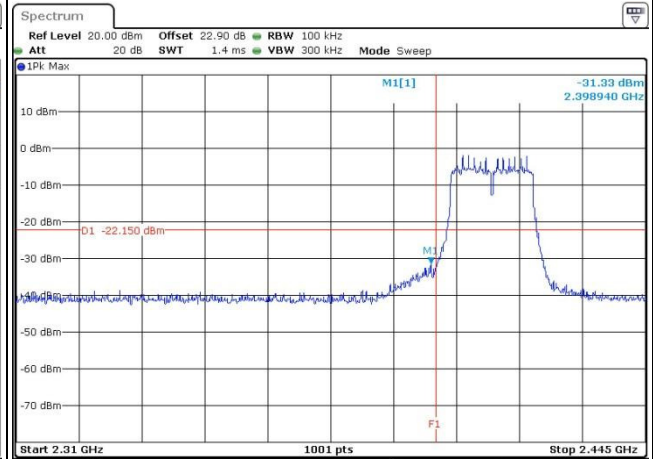

Date: 26 JUL 2016 00:57:34

Spurious Emission 30MHz~3GHz

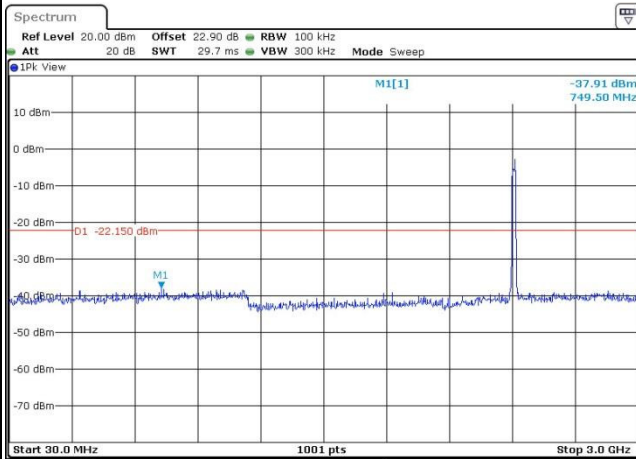

Date: 26 JUL 2016 00:57:47

Spurious Emission 2GHz~25GHz

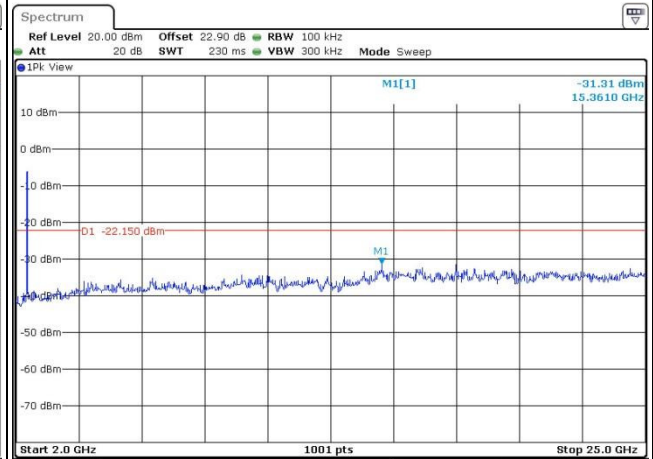

Date: 26 JUL 2016 00:57:56



Test Mode :	802.11n HT20	Temperature :	21~25°C
Test Band :	2.4GHz Mid	Relative Humidity :	51~54%
Test Channel :	06	Test Engineer :	Aking Chang

WLAN 802.11n HT20 Channel 06

100kHz PSD reference Level

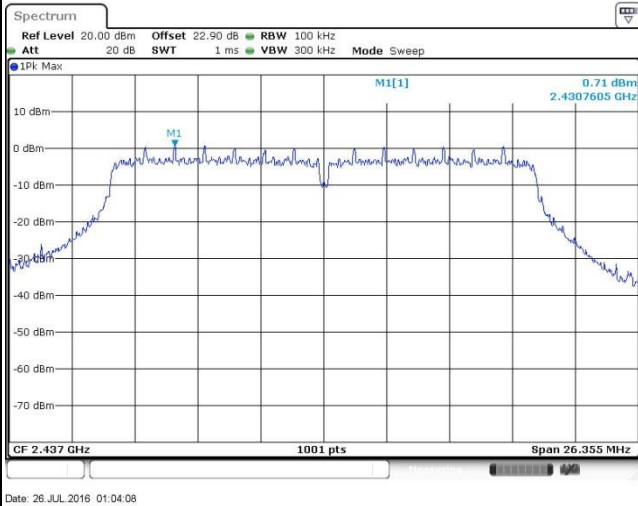

Spurious Emission 30MHz~3GHz

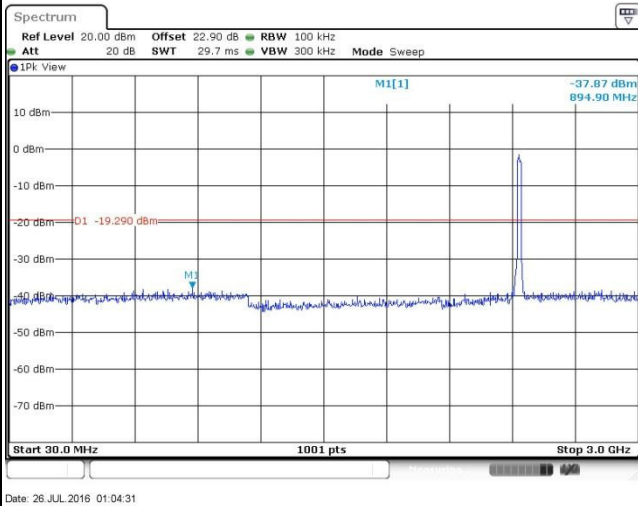

Spurious Emission 2GHz~25GHz

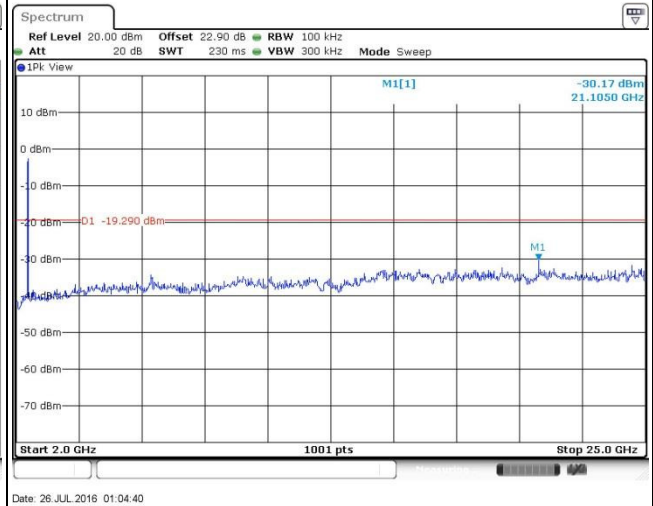



Test Mode :	802.11n HT20	Temperature :	21~25°C
Test Band :	2.4GHz High	Relative Humidity :	51~54%
Test Channel :	11	Test Engineer :	Aking Chang

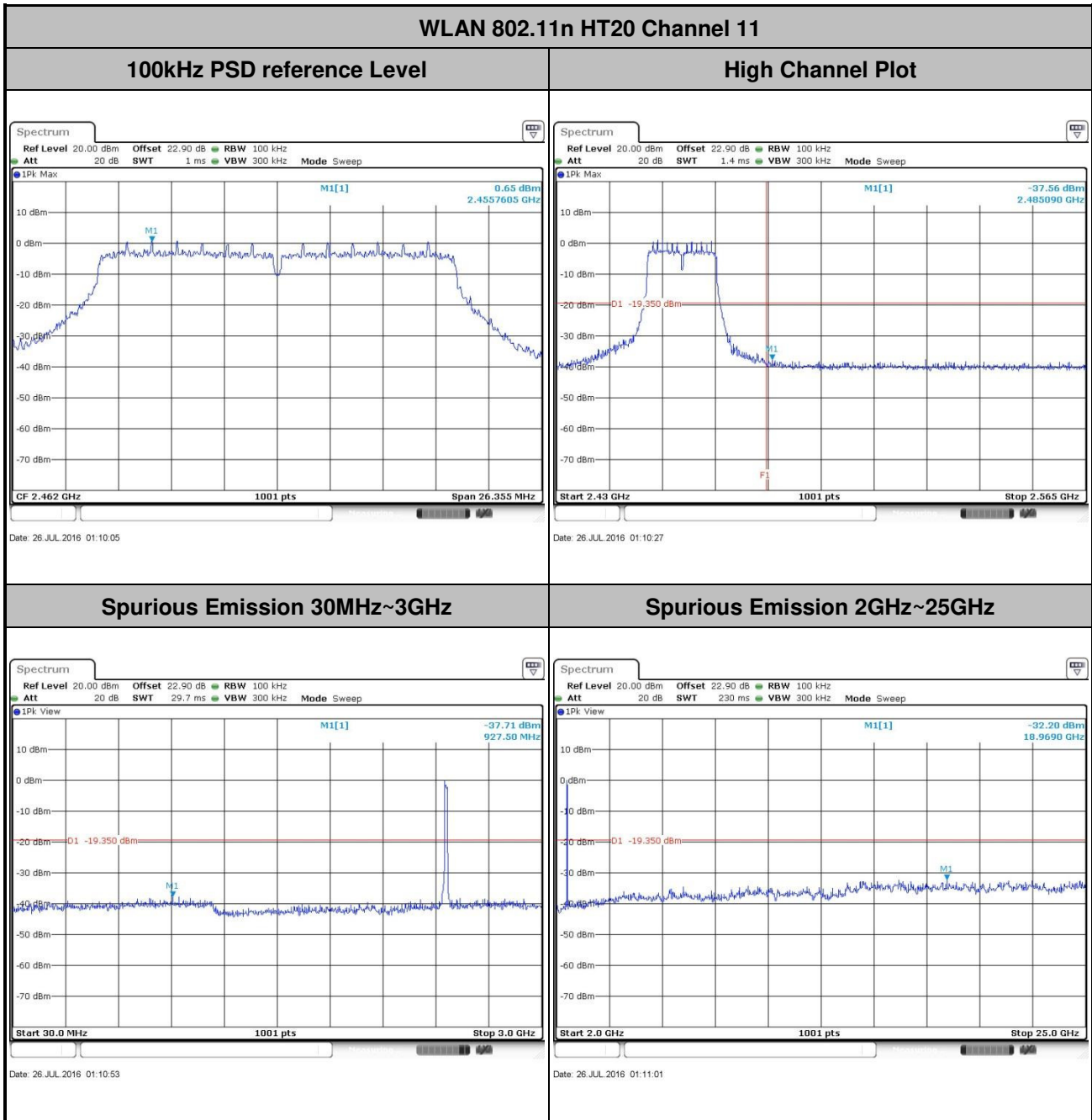



3.5 Radiated Band Edges and Spurious Emission Measurement

3.5.1 Limit of Radiated band edge and Spurious Emission Measurement

In any 100 kHz bandwidth outside the intentional radiator frequency band, all harmonics/spurious must be at least 20 dB below the highest emission level within the authorized band. If the output power of this device was measured by spectrum analyzer, the attenuation under this paragraph shall be 30 dB instead of 20 dB. In addition, radiated emissions which fall in the restricted bands must also comply with the FCC section 15.209 limits as below.

Frequency (MHz)	Field Strength (microvolts/meter)	Measurement Distance (meters)
0.009 – 0.490	2400/F(kHz)	300
0.490 – 1.705	24000/F(kHz)	30
1.705 – 30.0	30	30
30 – 88	100	3
88 – 216	150	3
216 - 960	200	3
Above 960	500	3

3.5.2 Measuring Instruments

The measuring equipment is listed in the section 4 of this test report.



3.5.3 Test Procedures

1. The testing follows FCC KDB Publication No. 558074 D01 DTS Meas. Guidance v03r05.
2. The EUT was arranged to its worst case and then tune the antenna tower (from 1 m to 4 m) and turntable (from 0 degree to 360 degrees) to find the maximum reading. A pre-amp and a high pass filter are used for the test in order to get better signal level.
3. The EUT was placed on a turntable with 0.8 meter for frequency below 1GHz and 1.5 meter for frequency above 1GHz respectively above ground.
4. The EUT was set 3 meters from the interference receiving antenna, which was mounted on the top of a variable height antenna tower.
5. Corrected Reading: Antenna Factor + Cable Loss + Read Level - Preamp Factor = Level
6. For measurement below 1GHz, If the emission level of the EUT measured by the peak detector is 3 dB lower than the applicable limit, the peak emission level will be reported. Otherwise, the emission measurement will be repeated using the quasi-peak detector and reported.
7. Use the following spectrum analyzer settings:
 - (1) Span shall wide enough to fully capture the emission being measured;
 - (2) Set RBW=100 kHz for $f < 1$ GHz; VBW \geq RBW; Sweep = auto; Detector function = peak; Trace = max hold;
 - (3) Set RBW = 1 MHz, VBW= 3MHz for $f \geq 1$ GHz for peak measurement.
For average measurement:
 - VBW = 10 Hz, when duty cycle is no less than 98 percent.
 - VBW $\geq 1/T$, when duty cycle is less than 98 percent where T is the minimum transmission duration over which the transmitter is on and is transmitting at its maximum power control level for the tested mode of operation.

3.5.4 Test Setup

For radiated emissions below 30MHz

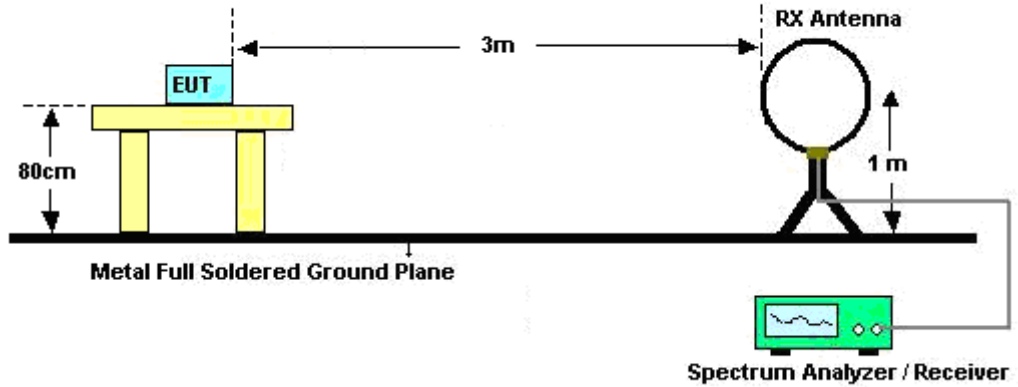

For radiated emissions from 30MHz to 1GHz

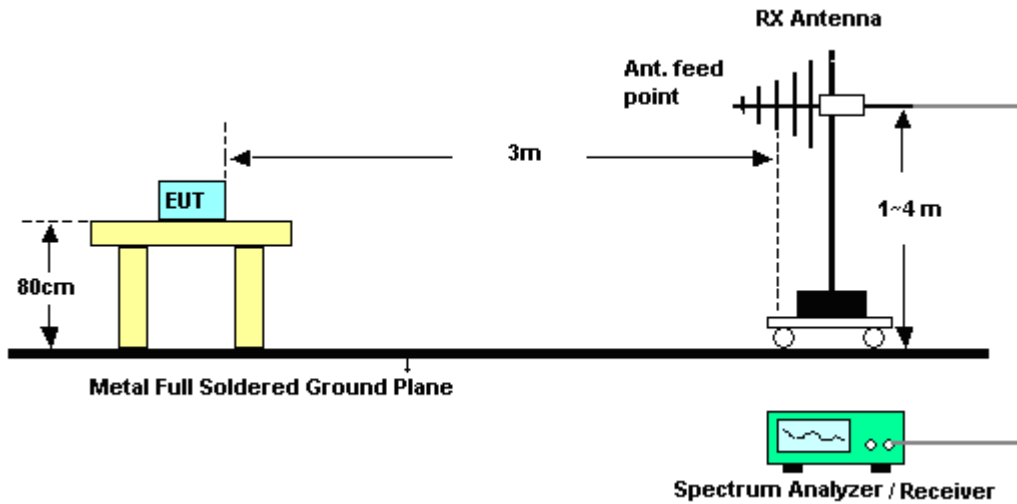

For radiated emissions above 1GHz

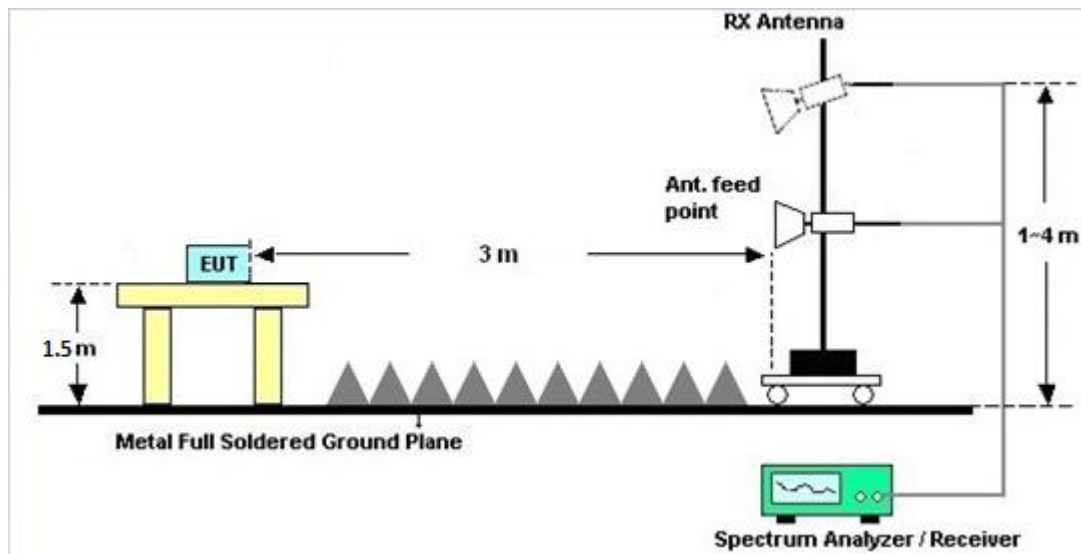

3.5.5 Test Results of Radiated Spurious Emissions (9kHz ~ 30MHz)

The low frequency, which started from 9 kHz to 30MHz, was pre-scanned and the result which was 20dB lower than the limit line per 15.31(o) was not reported.

3.5.6 Test Result of Radiated Spurious at Band Edges

Please refer to Appendix B and C.

3.5.7 Duty Cycle

Please refer to Appendix D.

3.5.8 Test Result of Radiated Spurious Emission (30MHz ~ 10th Harmonic)

Please refer to Appendix B and C.



3.6 AC Conducted Emission Measurement

3.6.1 Limit of AC Conducted Emission

For equipment that is designed to be connected to the public utility (AC) power line, the radio frequency voltage that is conducted back onto the AC power line on any frequency or frequencies within the band 150 kHz to 30 MHz shall not exceed the limits in the following table.

Frequency of Emission (MHz)	Conducted Limit (dB μ V)	
	Quasi-Peak	Average
0.15-0.5	66 to 56*	56 to 46*
0.5-5	56	46
5-30	60	50

*Decreases with the logarithm of the frequency.

3.6.2 Measuring Instruments

The measuring equipment is listed in the section 4 of this test report.

3.6.3 Test Procedures

1. The EUT was placed 0.4 meter from the conducting wall of the shielding room, and it was kept at least 80 centimeters from any other grounded conducting surface.
2. Connect EUT to the power mains through a line impedance stabilization network (LISN).
3. All the support units are connecting to the other LISN.
4. The LISN provides 50 ohm coupling impedance for the measuring instrument.
5. The FCC states that a 50 ohm, 50 microhenry LISN should be used.
6. Both sides of AC line were checked for maximum conducted interference.
7. The frequency range from 150 kHz to 30 MHz was searched.
8. Set the test-receiver system to Peak Detect Function and specified bandwidth (IF bandwidth = 9kHz) with Maximum Hold Mode.

3.6.4 Test Setup

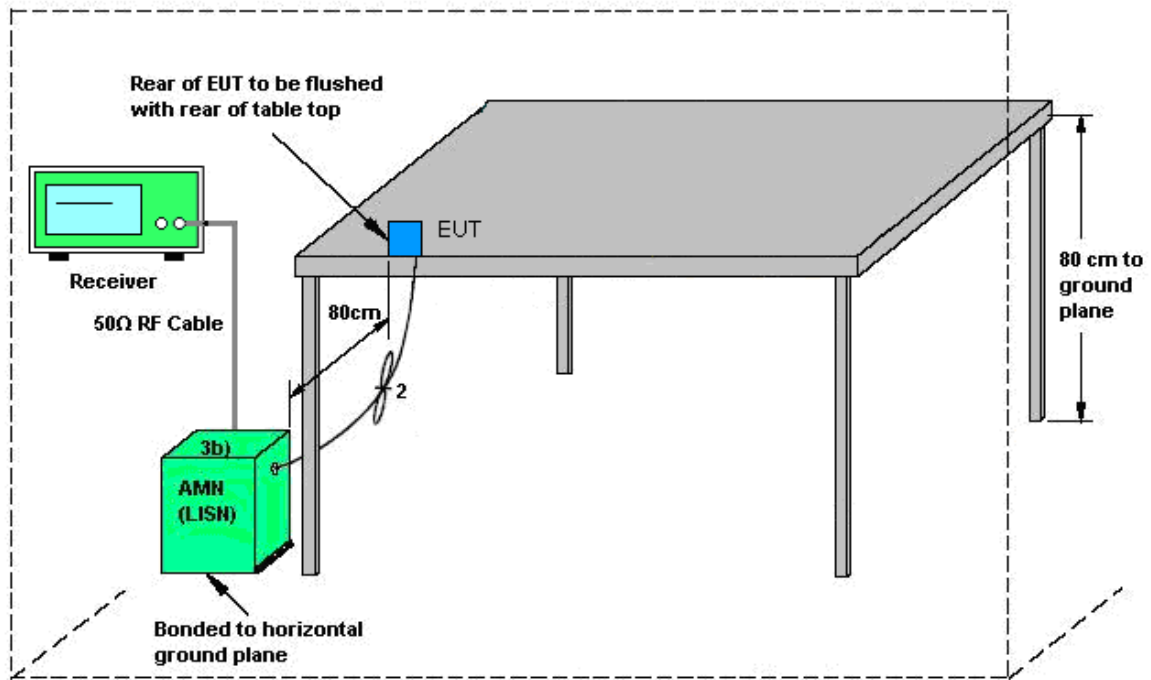

AMN = Artificial mains network (LISN)
AE = Associated equipment
EUT = Equipment under test
ISN = Impedance stabilization network

3.6.5 Test Result of AC Conducted Emission

Test Mode :	Mode 1	Temperature :	23~24°C
Test Engineer :	Arthur Hsieh	Relative Humidity :	51~52%
Test Voltage :	120Vac / 60Hz	Phase :	Line
Function Type :	Bluetooth Link + WLAN Link + SD Card + MPEG4 + USB Cable (Data Link with Notebook)		

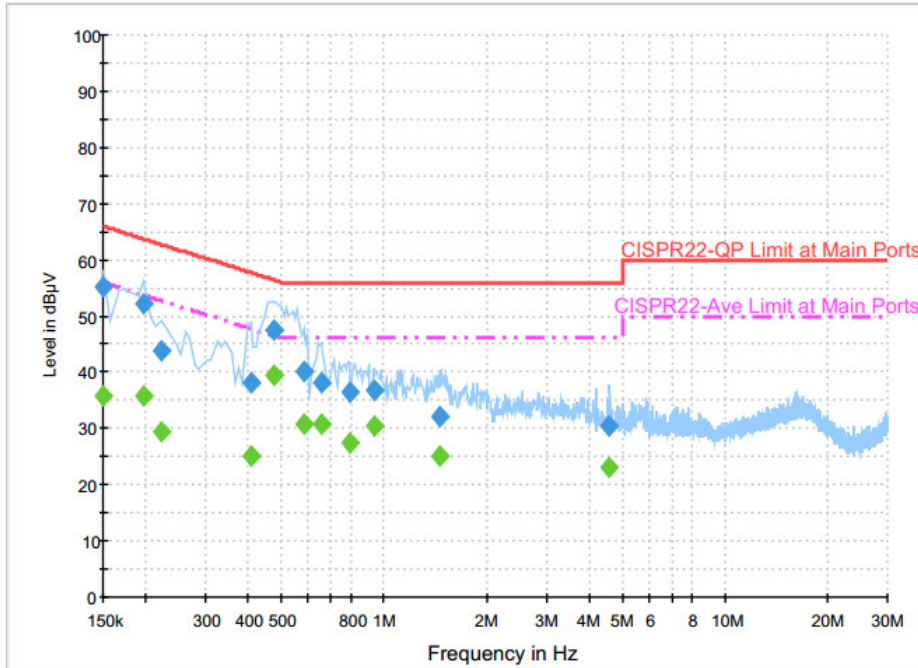

Final Result : Quasi-Peak

Frequency (MHz)	Quasi-Peak (dBµV)	Filter	Line	Corr. (dB)	Margin (dB)	Limit (dBµV)
0.150000	55.1	Off	L1	19.6	10.9	66.0
0.198000	52.3	Off	L1	19.6	11.4	63.7
0.222000	43.7	Off	L1	19.6	19.0	62.7
0.406000	38.3	Off	L1	19.6	19.4	57.7
0.478000	47.4	Off	L1	19.6	9.0	56.4
0.582000	40.1	Off	L1	19.6	15.9	56.0
0.654000	38.3	Off	L1	19.6	17.7	56.0
0.790000	36.4	Off	L1	19.6	19.6	56.0
0.934000	36.7	Off	L1	19.6	19.3	56.0
1.454000	32.1	Off	L1	19.6	23.9	56.0
4.598000	30.3	Off	L1	19.7	25.7	56.0



Test Mode :	Mode 1	Temperature :	23~24°C
Test Engineer :	Arthur Hsieh	Relative Humidity :	51~52%
Test Voltage :	120Vac / 60Hz	Phase :	Line
Function Type :	Bluetooth Link + WLAN Link + SD Card + MPEG4 + USB Cable (Data Link with Notebook)		

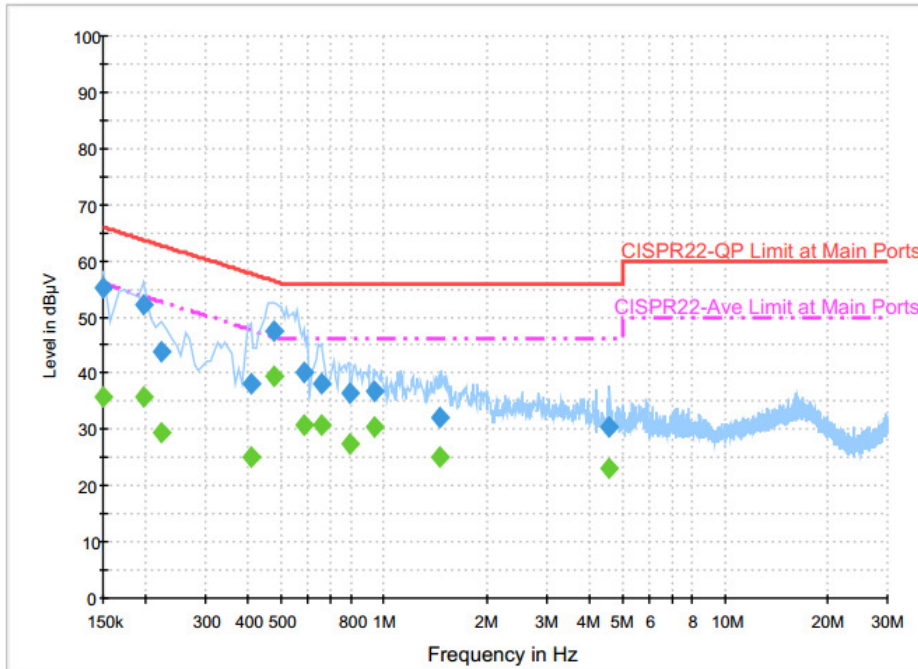

Final Result : Average

Frequency (MHz)	Average (dBµV)	Filter	Line	Corr. (dB)	Margin (dB)	Limit (dBµV)
0.150000	35.9	Off	L1	19.6	20.1	56.0
0.198000	35.6	Off	L1	19.6	18.1	53.7
0.222000	29.3	Off	L1	19.6	23.4	52.7
0.406000	25.2	Off	L1	19.6	22.5	47.7
0.478000	39.6	Off	L1	19.6	6.8	46.4
0.582000	30.9	Off	L1	19.6	15.1	46.0
0.654000	30.7	Off	L1	19.6	15.3	46.0
0.790000	27.3	Off	L1	19.6	18.7	46.0
0.934000	30.6	Off	L1	19.6	15.4	46.0
1.454000	25.0	Off	L1	19.6	21.0	46.0
4.598000	23.1	Off	L1	19.7	22.9	46.0



Test Mode :	Mode 1	Temperature :	23~24°C
Test Engineer :	Arthur Hsieh	Relative Humidity :	51~52%
Test Voltage :	120Vac / 60Hz	Phase :	Neutral
Function Type :	Bluetooth Link + WLAN Link + SD Card + MPEG4 + USB Cable (Data Link with Notebook)		

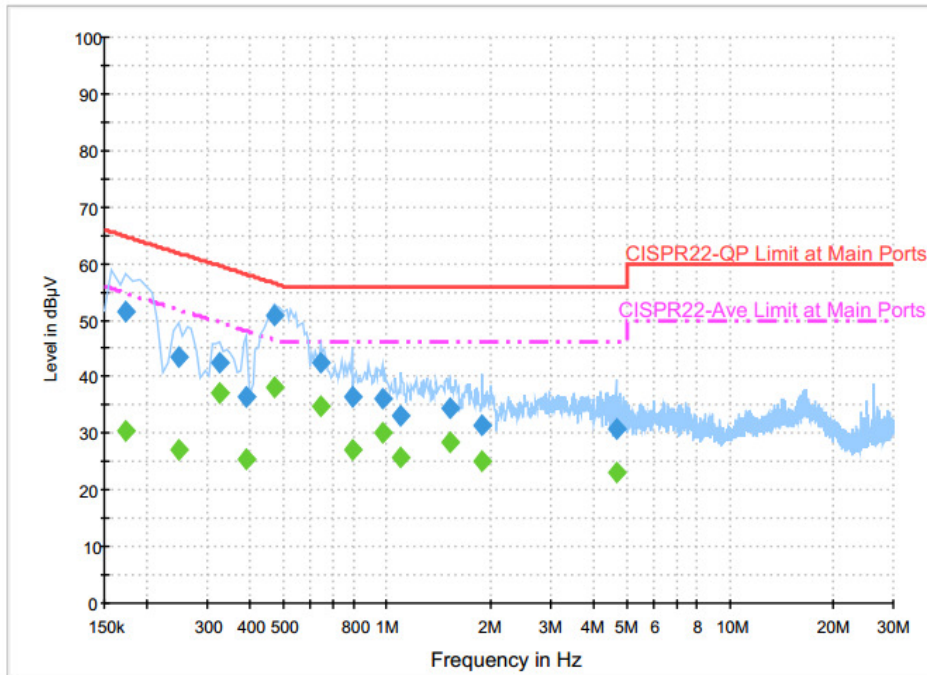

Final Result : Quasi-Peak

Frequency (MHz)	Quasi-Peak (dBµV)	Filter	Line	Corr. (dB)	Margin (dB)	Limit (dBµV)
0.174000	51.5	Off	N	19.6	13.3	64.8
0.246000	43.3	Off	N	19.6	18.6	61.9
0.326000	42.6	Off	N	19.6	17.0	59.6
0.390000	36.4	Off	N	19.6	21.7	58.1
0.470000	50.8	Off	N	19.6	5.7	56.5
0.638000	42.6	Off	N	19.6	13.4	56.0
0.790000	36.4	Off	N	19.6	19.6	56.0
0.974000	36.2	Off	N	19.6	19.8	56.0
1.102000	33.2	Off	N	19.6	22.8	56.0
1.526000	34.3	Off	N	19.6	21.7	56.0
1.894000	31.5	Off	N	19.6	24.5	56.0
4.662000	30.8	Off	N	19.7	25.2	56.0



Test Mode :	Mode 1	Temperature :	23~24°C
Test Engineer :	Arthur Hsieh	Relative Humidity :	51~52%
Test Voltage :	120Vac / 60Hz	Phase :	Neutral
Function Type :	Bluetooth Link + WLAN Link + SD Card + MPEG4 + USB Cable (Data Link with Notebook)		

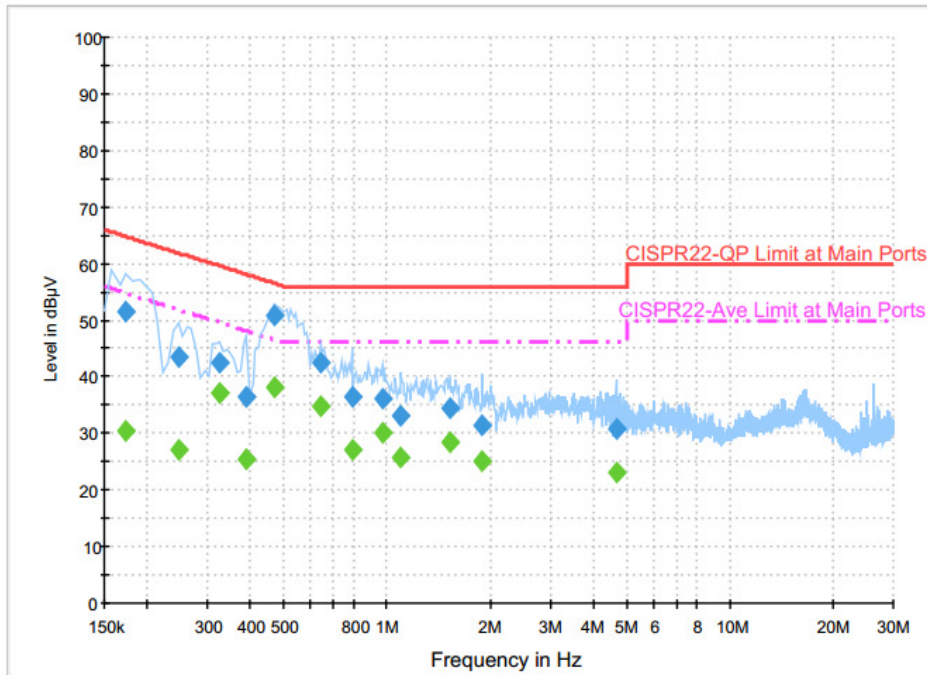

Final Result : Average

Frequency (MHz)	Average (dBµV)	Filter	Line	Corr. (dB)	Margin (dB)	Limit (dBµV)
0.174000	30.4	Off	N	19.6	24.4	54.8
0.246000	27.1	Off	N	19.6	24.8	51.9
0.326000	37.0	Off	N	19.6	12.6	49.6
0.390000	25.5	Off	N	19.6	22.6	48.1
0.470000	38.2	Off	N	19.6	8.3	46.5
0.638000	34.9	Off	N	19.6	11.1	46.0
0.790000	26.9	Off	N	19.6	19.1	46.0
0.974000	30.0	Off	N	19.6	16.0	46.0
1.102000	25.7	Off	N	19.6	20.3	46.0
1.526000	28.5	Off	N	19.6	17.5	46.0
1.894000	25.2	Off	N	19.6	20.8	46.0
4.662000	23.1	Off	N	19.7	22.9	46.0



3.7 Antenna Requirements

3.7.1 Standard Applicable

If directional gain of transmitting antennas is greater than 6dBi, the power shall be reduced by the same level in dB comparing to gain minus 6dBi. For the fixed point-to-point operation, the power shall be reduced by one dB for every 3 dB that the directional gain of the antenna exceeds 6 dBi. The use of a permanently attached antenna or of an antenna that uses a unique coupling to the intentional radiator shall be considered sufficient to comply with the FCC rule.

3.7.2 Antenna Anti-Replacement Construction

An embedded-in antenna design is used.

3.7.3 Antenna Gain

The antenna peak gain of EUT is less than 6 dBi. Therefore, it is not necessary to reduce maximum peak output power limit.



4 List of Measuring Equipment

Instrument	Manufacturer	Model No.	Serial No.	Characteristics	Calibration Date	Test Date	Due Date	Remark
Power Meter	Anritsu	ML2495A	0932001	300MHz~40GHz	Oct. 05, 2015	Jul. 19, 2016 ~ Aug. 12, 2016	Oct. 04, 2016	Conducted (TH05-HY)
Power Sensor	Anritsu	MA2411B	0846202	300MHz~40GHz	Oct. 05, 2015	Jul. 19, 2016 ~ Aug. 12, 2016	Oct. 04, 2016	Conducted (TH05-HY)
Spectrum Analyzer	Rohde & Schwarz	FSP40	100057	9kHz-40GHz	Nov. 23, 2015	Jul. 19, 2016 ~ Aug. 12, 2016	Nov. 22, 2016	Conducted (TH05-HY)
AC Power Source	ChainTek	APC-1000W	N/A	N/A	N/A	Jul. 20, 2016	N/A	Conduction (CO05-HY)
EMI Test Receiver	Rohde & Schwarz	ESCI 7	100724	9kHz~7GHz	Aug. 26, 2015	Jul. 20, 2016	Aug. 25, 2016	Conduction (CO05-HY)
LISN	Rohde & Schwarz	ENV216	100080	9kHz~30MHz	Dec. 02, 2015	Jul. 20, 2016	Dec. 01, 2016	Conduction (CO05-HY)
LISN	Rohde & Schwarz	ENV216	100081	9kHz~30MHz	Dec. 14, 2015	Jul. 20, 2016	Dec. 13, 2016	Conduction (CO05-HY)
Bilog Antenna	TESEQ	CBL 6111D	35419	30MHz to 1GHz	Jan. 13, 2016	Jul. 23, 2016 ~ Jul. 25, 2016	Jan. 12, 2017	Radiation (03CH07-HY)
Double Ridge Horn Antenna	ESCO	3117	00075962	1GHz ~ 18GHz	Aug. 21, 2015	Jul. 23, 2016 ~ Jul. 25, 2016	Aug. 20, 2016	Radiation (03CH07-HY)
EMI Test Receiver	Keysight	N9038A(MXE)	MY54130085	20Hz ~ 8.4GHz	Nov. 04, 2015	Jul. 23, 2016 ~ Jul. 25, 2016	Nov. 03, 2016	Radiation (03CH07-HY)
Loop Antenna	Rohde & Schwarz	HFH2-Z2	100315	9 kHz~30 MHz	Sep. 02, 2015	Jul. 23, 2016 ~ Jul. 25, 2016	Sep. 01, 2016	Radiation (03CH07-HY)
Preamplifier	MITEQ	AMF-7D-0010 1800-30-10P	1590075	1GHz ~ 18GHz	Apr. 15, 2016	Jul. 23, 2016 ~ Jul. 25, 2016	Apr. 14, 2017	Radiation (03CH07-HY)
Preamplifier	COM-POWER	PA-103A	161241	10MHz-1GHz	Mar. 18, 2016	Jul. 23, 2016 ~ Jul. 25, 2016	Mar. 17, 2017	Radiation (03CH07-HY)
Preamplifier	Agilent	8449B	3008A02362	1GHz~ 26.5GHz	Oct. 19, 2015	Jul. 23, 2016 ~ Jul. 25, 2016	Oct. 18, 2016	Radiation (03CH07-HY)
Spectrum Analyzer	Agilent	N9010A	MY53470118	10Hz~44GHz	Feb. 27, 2016	Jul. 23, 2016 ~ Jul. 25, 2016	Feb. 26, 2017	Radiation (03CH07-HY)
Antenna Mast	Max-Full	MFA520BS	N/A	1m~4m	N/A	Jul. 23, 2016 ~ Jul. 25, 2016	N/A	Radiation (03CH07-HY)
Turn Table	ChainTek	Chaintek 3000	N/A	0~360 Degree	N/A	Jul. 23, 2016 ~ Jul. 25, 2016	N/A	Radiation (03CH07-HY)
Loop Cable	Rohde & Schwarz	N/A	N/A	9KHz~30MHz	Dec. 03, 2015	Jul. 23, 2016 ~ Jul. 25, 2016	Dec. 02, 2016	Radiation (03CH07-HY)
Preamplifier	MITEQ	TTA0204	1872107	2GHz~40GHz	Feb. 15, 2015	Jul. 23, 2016 ~ Jul. 25, 2016	Feb. 14, 2017	Radiation (03CH07-HY)
SHF-EHF Horn Antenna	SCHWARZBECK	BBHA 9170	BBHA9170584	18GHz- 40GHz	Nov. 02, 2015	Jul. 23, 2016 ~ Jul. 25, 2016	Nov. 01, 2016	Radiation (03CH07-HY)



5 Uncertainty of Evaluation

Uncertainty of Conducted Emission Measurement (150kHz ~ 30MHz)

Measuring Uncertainty for a Level of Confidence of 95% ($U = 2Uc(y)$)	2.26
-------------------------------------------------------------------------	------

Uncertainty of Radiated Emission Measurement (30 MHz ~ 1000 MHz)

Measuring Uncertainty for a Level of Confidence of 95% ($U = 2Uc(y)$)	5.70
-------------------------------------------------------------------------	------



Appendix A. Conducted Test Results

A1 - DTS Part

Test Engineer:	Aking Chang	Temperature:	21~25	°C
Test Date:	2016/07/19 ~ 2016/08/12	Relative Humidity:	51~54	%

TEST RESULTS DATA
6dB and 99% Occupied Bandwidth

2.4GHz Band								
Mod.	Data Rate	N _{TX}	CH.	Freq. (MHz)	99% Occupied BW (MHz)	6dB BW (MHz)	6dB BW Limit (MHz)	Pass/Fail
11b	1Mbps	1	1	2412	13.35	8.00	0.50	Pass
11b	1Mbps	1	6	2437	13.39	8.06	0.50	Pass
11b	1Mbps	1	11	2462	13.49	8.07	0.50	Pass
11g	6Mbps	1	1	2412	18.35	16.32	0.50	Pass
11g	6Mbps	1	6	2437	18.63	16.37	0.50	Pass
11g	6Mbps	1	11	2462	18.58	16.38	0.50	Pass
HT20	MCS0	1	1	2412	19.38	17.58	0.50	Pass
HT20	MCS0	1	6	2437	19.33	17.57	0.50	Pass
HT20	MCS0	1	11	2462	19.48	17.58	0.50	Pass

TEST RESULTS DATA
Peak Power Table

2.4GHz Band										
Mod.	Data Rate	N _{TX}	CH.	Freq. (MHz)	Peak Conducted Power (dBm)	Conducted Power Limit (dBm)	DG (dBi)	EIRP Power (dBm)	EIRP Power Limit (dBm)	Pass /Fail
11b	1Mbps	1	1	2412	14.15	30.00	1.50	15.65	36.00	Pass
11b	1Mbps	1	6	2437	14.46	30.00	1.50	15.96	36.00	Pass
11b	1Mbps	1	11	2462	14.89	30.00	1.50	16.39	36.00	Pass
11g	6Mbps	1	1	2412	20.45	30.00	1.50	21.95	36.00	Pass
11g	6Mbps	1	6	2437	21.17	30.00	1.50	22.67	36.00	Pass
11g	6Mbps	1	11	2462	21.22	30.00	1.50	22.72	36.00	Pass
HT20	MCS0	1	1	2412	19.90	30.00	1.50	21.40	36.00	Pass
HT20	MCS0	1	6	2437	21.21	30.00	1.50	22.71	36.00	Pass
HT20	MCS0	1	11	2462	21.34	30.00	1.50	22.84	36.00	Pass

TEST RESULTS DATA
Average Power Table
(Reporting Only)

2.4GHz Band						
Mod.	Data Rate	N _{TX}	CH.	Freq. (MHz)	Duty Factor (dB)	Average Conducted Power (dBm)
11b	1Mbps	1	1	2412	0.13	9.10
11b	1Mbps	1	6	2437	0.13	11.67
11b	1Mbps	1	11	2462	0.13	12.00
11g	6Mbps	1	1	2412	0.65	8.95
11g	6Mbps	1	6	2437	0.65	11.65
11g	6Mbps	1	11	2462	0.65	12.15
HT20	MCS0	1	1	2412	0.70	9.35
HT20	MCS0	1	6	2437	0.70	11.75
HT20	MCS0	1	11	2462	0.70	12.20

TEST RESULTS DATA
Peak Power Density

2.4GHz Band								
Mod.	Data Rate	N _{TX}	CH.	Freq. (MHz)	Peak PSD (dBm /3kHz)	DG (dBi)	Peak PSD Limit (dBm /3kHz)	Pass/Fail
11b	1Mbps	1	1	2412	-14.18	1.50	8.00	Pass
11b	1Mbps	1	6	2437	-9.20	1.50	8.00	Pass
11b	1Mbps	1	11	2462	-10.76	1.50	8.00	Pass
11g	6Mbps	1	1	2412	-16.45	1.50	8.00	Pass
11g	6Mbps	1	6	2437	-13.17	1.50	8.00	Pass
11g	6Mbps	1	11	2462	-11.90	1.50	8.00	Pass
HT20	MCS0	1	1	2412	-16.00	1.50	8.00	Pass
HT20	MCS0	1	6	2437	-13.11	1.50	8.00	Pass
HT20	MCS0	1	11	2462	-13.49	1.50	8.00	Pass



Appendix B. Radiated Spurious Emission

Test Engineer :	Luke Chang, Jesse Wang, Derreck Chen,	Temperature :	21~23°C
	James Chiu	Relative Humidity :	60~63%

2.4GHz 2400~2483.5MHz

WIFI 802.11b (Band Edge @ 3m)

WIFI	Note	Frequency	Level	Over	Limit	Read	Antenna	Cable	Preamp	Ant	Table	Peak	Pol.
Ant.				Limit	Line	Level	Factor	Loss	Factor	Pos	Pos	Avg.	
1		(MHz)	(dBμV/m)	(dB)	(dBμV/m)	(dBμV)	(dB/m)	(dB)	(dB)	(cm)	(deg)	(P/A)	(H/V)
802.11b CH 01 2412MHz		2350.635	55.25	-18.75	74	50.61	31.8	7.24	34.4	100	7	P	H
		2382.45	44.56	-9.44	54	39.71	31.89	7.31	34.35	100	7	A	H
		2412	96.4	-34.9	131.3	91.41	31.98	7.31	34.3	100	7	P	H
		2412	93.23	-38.07	131.3	88.24	31.98	7.31	34.3	100	7	A	H
		2388.54	55.88	-18.12	74	50.98	31.93	7.31	34.34	102	7	P	V
		2390	46.11	-7.89	54	41.2	31.93	7.31	34.33	102	7	A	V
		2412	104.2	-27.1	131.3	99.21	31.98	7.31	34.3	102	7	P	V
		2412	100.94	-30.36	131.3	95.95	31.98	7.31	34.3	102	7	A	V
802.11b CH 06 2437MHz		2381.68	55.41	-18.59	74	50.56	31.89	7.31	34.35	289	114	P	H
		2387.42	44.58	-9.42	54	39.68	31.93	7.31	34.34	289	114	A	H
		2437	96.06	-35.24	131.3	90.88	32.07	7.36	34.25	289	114	P	H
		2437	92.81	-38.49	131.3	87.63	32.07	7.36	34.25	289	114	A	H
		2484.81	56.09	-17.91	74	50.71	32.16	7.4	34.18	289	114	P	H
		2493	45.06	-8.94	54	39.62	32.2	7.4	34.16	289	114	A	H
		2369.92	55.69	-18.31	74	50.93	31.89	7.24	34.37	124	6	P	V
		2381.54	45.52	-8.48	54	40.67	31.89	7.31	34.35	124	6	A	V
		2437	101.68	-29.62	131.3	96.5	32.07	7.36	34.25	124	6	P	V
		2437	98.4	-32.9	131.3	93.22	32.07	7.36	34.25	124	6	A	V
		2483.83	55.36	-18.64	74	49.98	32.16	7.4	34.18	124	6	P	V
		2490.55	45.05	-8.95	54	39.62	32.2	7.4	34.17	124	6	A	V



802.11b CH 11 2462MHz		2462	94.48	-36.82	131.3	89.18	32.11	7.4	34.21	228	13	P	H
		2462	91.26	-40.04	131.3	85.96	32.11	7.4	34.21	228	13	A	H
		2484.92	55.38	-18.62	74	50	32.16	7.4	34.18	228	13	P	H
		2499.6	45.05	-8.95	54	39.6	32.2	7.4	34.15	228	13	A	H
		2462	99.91	-31.39	131.3	94.61	32.11	7.4	34.21	103	8	P	V
		2462	96.68	-34.62	131.3	91.38	32.11	7.4	34.21	103	8	A	V
		2484.32	55.11	-18.89	74	49.73	32.16	7.4	34.18	103	8	P	V
		2496.48	45.05	-8.95	54	39.61	32.2	7.4	34.16	103	8	A	V
Remark	1. No other spurious found. 2. All results are PASS against Peak and Average limit line.												



2.4GHz 2400~2483.5MHz

WIFI 802.11b (Harmonic @ 3m)

WIFI Ant. 1	Note	Frequency (MHz)	Level (dBμV/m)	Over Limit (dB)	Limit Line (dBμV/m)	Read Level (dBμV)	Antenna Factor (dB/m)	Cable Loss (dB)	Preamp Factor (dB)	Ant Pos (cm)	Table Pos (deg)	Peak Avg. (P/A)	Pol. (H/V)
802.11b CH 01 2412MHz		4824	40.19	-33.81	74	53.35	34.2	11.68	59.04	100	0	P	H
		4824	40.64	-33.36	74	53.8	34.2	11.68	59.04	100	0	P	V
802.11b CH 06 2437MHz		4872	39.86	-34.14	74	53.04	34.23	11.53	58.94	100	0	P	H
		7308	39.7	-34.3	74	48.22	35.6	13.81	57.93	100	0	P	H
		4872	40.22	-33.78	74	53.4	34.23	11.53	58.94	100	0	P	V
		7308	39.34	-34.66	74	47.86	35.6	13.81	57.93	100	0	P	V
802.11b CH 11 2462MHz		4926	39.8	-34.2	74	53.01	34.26	11.37	58.84	100	0	P	H
		7386	40.27	-33.73	74	48.78	35.6	13.95	58.06	100	0	P	H
		4926	41.81	-32.19	74	55.02	34.26	11.37	58.84	100	0	P	V
		7386	39.47	-34.53	74	47.98	35.6	13.95	58.06	100	0	P	V
Remark	1. No other spurious found. 2. All results are PASS against Peak and Average limit line.												



2.4GHz 2400~2483.5MHz

WIFI 802.11g (Band Edge @ 3m)

WIFI Ant. 1	Note	Frequency (MHz)	Level (dBμV/m)	Over Limit (dB)	Limit Line (dBμV/m)	Read Level (dBμV)	Antenna Factor (dB/m)	Cable Loss (dB)	Preamp Factor (dB)	Ant Pos (cm)	Table Pos (deg)	Peak Avg. (P/A)	Pol. (H/V)
802.11g CH 01 2412MHz		2389.485	56.22	-17.78	74	51.31	31.93	7.31	34.33	100	6	P	H
		2389.8	46.3	-7.7	54	41.39	31.93	7.31	34.33	100	6	A	H
		2412	98.99	-32.31	131.3	94	31.98	7.31	34.3	100	6	P	H
		2412	89.58	-41.72	131.3	84.59	31.98	7.31	34.3	100	6	A	H
		2390	68.27	-5.73	74	63.36	31.93	7.31	34.33	102	7	P	V
		2390	53.54	-0.46	54	48.63	31.93	7.31	34.33	102	7	A	V
		2412	105.35	-25.95	131.3	100.36	31.98	7.31	34.3	102	7	P	V
		2412	97.3	-34	131.3	92.31	31.98	7.31	34.3	102	7	A	V
802.11g CH 06 2437MHz		2371.6	54.62	-19.38	74	49.85	31.89	7.24	34.36	288	114	P	H
		2388.68	45.22	-8.78	54	40.31	31.93	7.31	34.33	288	114	A	H
		2437	98.04	-33.26	131.3	92.86	32.07	7.36	34.25	288	114	P	H
		2437	90.13	-41.17	131.3	84.95	32.07	7.36	34.25	288	114	A	H
		2484.46	55.16	-18.84	74	49.78	32.16	7.4	34.18	288	114	P	H
		2496.22	45.5	-8.5	54	40.06	32.2	7.4	34.16	288	114	A	H
		2385.04	56.98	-17.02	74	52.12	31.89	7.31	34.34	100	5	P	V
		2384.9	48.42	-5.58	54	43.56	31.89	7.31	34.34	100	5	A	V
		2437	103.19	-28.11	131.3	98.01	32.07	7.36	34.25	100	5	P	V
		2437	95.24	-36.06	131.3	90.06	32.07	7.36	34.25	100	5	A	V
		2486.49	55.41	-18.59	74	50.02	32.16	7.4	34.17	100	5	P	V
		2489.5	45.58	-8.42	54	40.15	32.2	7.4	34.17	100	5	A	V



802.11g CH 11 2462MHz		2462	96.56	-34.74	131.3	91.26	32.11	7.4	34.21	227	357	P	H
		2462	87.37	-43.93	131.3	82.07	32.11	7.4	34.21	227	357	A	H
		2484.52	55.72	-18.28	74	50.34	32.16	7.4	34.18	227	357	P	H
		2490.32	45.58	-8.42	54	40.15	32.2	7.4	34.17	227	357	A	H
		2462	101.84	-29.46	131.3	96.54	32.11	7.4	34.21	105	22	P	V
		2462	93.2	-38.1	131.3	87.9	32.11	7.4	34.21	105	22	A	V
		2483.6	57.54	-16.46	74	52.16	32.16	7.4	34.18	105	22	P	V
		2483.52	45.87	-8.13	54	40.49	32.16	7.4	34.18	105	22	A	V
Remark	<ol style="list-style-type: none">1. No other spurious found.2. All results are PASS against Peak and Average limit line.												



2.4GHz 2400~2483.5MHz

WIFI 802.11g (Harmonic @ 3m)

WIFI Ant. 1	Note	Frequency (MHz)	Level (dBμV/m)	Over Limit (dB)	Limit Line (dBμV/m)	Read Level (dBμV)	Antenna Factor (dB/m)	Cable Loss (dB)	Preamp Factor (dB)	Ant Pos (cm)	Table Pos (deg)	Peak Avg. (P/A)	Pol. (H/V)
802.11g CH 01 2412MHz		4824	40.88	-33.12	74	54.04	34.2	11.68	59.04	100	0	P	H
		4824	40.65	-33.35	74	53.81	34.2	11.68	59.04	100	0	P	V
802.11g CH 06 2437MHz		4872	40.42	-33.58	74	53.6	34.23	11.53	58.94	100	0	P	H
		7308	40.74	-33.26	74	49.26	35.6	13.81	57.93	100	0	P	H
		4872	40.42	-33.58	74	53.6	34.23	11.53	58.94	100	0	P	V
		7308	40.03	-33.97	74	48.55	35.6	13.81	57.93	100	0	P	V
802.11g CH 11 2462MHz		4926	39.48	-34.52	74	52.69	34.26	11.37	58.84	100	0	P	H
		7386	40.17	-33.83	74	48.68	35.6	13.95	58.06	100	0	P	H
		4926	39.36	-34.64	74	52.57	34.26	11.37	58.84	100	0	P	V
		7386	40.4	-33.6	74	48.91	35.6	13.95	58.06	100	0	P	V
Remark	1. No other spurious found. 2. All results are PASS against Peak and Average limit line.												



2.4GHz 2400~2483.5MHz

WIFI 802.11n HT20 (Band Edge @ 3m)

WIFI Ant. 1	Note	Frequency (MHz)	Level (dBμV/m)	Over Limit (dB)	Limit Line (dBμV/m)	Read Level (dBμV)	Antenna Factor (dB/m)	Cable Loss (dB)	Preamp Factor (dB)	Ant Pos (cm)	Table Pos (deg)	Peak Avg. (P/A)	Pol. (H/V)
802.11n HT20 CH 01 2412MHz		2389.38	55.82	-18.18	74	50.91	31.93	7.31	34.33	100	7	P	H
		2389.38	46.15	-7.85	54	41.24	31.93	7.31	34.33	100	7	A	H
		2412	96.1	-35.2	131.3	91.11	31.98	7.31	34.3	100	7	P	H
		2412	88.21	-43.09	131.3	83.22	31.98	7.31	34.3	100	7	A	H
		2389.8	64.95	-9.05	74	60.04	31.93	7.31	34.33	100	7	P	V
		2390	52.98	-1.02	54	48.07	31.93	7.31	34.33	100	7	A	V
		2412	103.78	-27.52	131.3	98.79	31.98	7.31	34.3	100	7	P	V
		2412	95.9	-35.4	131.3	90.91	31.98	7.31	34.3	100	7	A	V
802.11n HT20 CH 06 2437MHz		2382.52	54.34	-19.66	74	49.49	31.89	7.31	34.35	289	113	P	H
		2384.2	45.15	-8.85	54	40.29	31.89	7.31	34.34	289	113	A	H
		2437	97.63	-33.67	131.3	92.45	32.07	7.36	34.25	289	113	P	H
		2437	89.83	-41.47	131.3	84.65	32.07	7.36	34.25	289	113	A	H
		2497.9	54.85	-19.15	74	49.4	32.2	7.4	34.15	289	113	P	H
		2492.72	45.5	-8.5	54	40.06	32.2	7.4	34.16	289	113	A	H
		2385.74	57.5	-16.5	74	52.6	31.93	7.31	34.34	100	6	P	V
		2385.46	48.85	-5.15	54	43.99	31.89	7.31	34.34	100	6	A	V
		2437	103.47	-27.83	131.3	98.29	32.07	7.36	34.25	100	6	P	V
		2437	95.68	-35.62	131.3	90.5	32.07	7.36	34.25	100	6	A	V
		2487.75	55.25	-18.75	74	49.82	32.2	7.4	34.17	100	6	P	V
	2489.57	45.71	-8.29	54	40.28	32.2	7.4	34.17	100	6	A	V	



802.11n HT20 CH 11 2462MHz		2462	96.25	-35.05	131.3	90.95	32.11	7.4	34.21	226	14	P	H
		2462	88.47	-42.83	131.3	83.17	32.11	7.4	34.21	226	14	A	H
		2488.92	55.56	-18.44	74	50.13	32.2	7.4	34.17	226	14	P	H
		2483.88	45.84	-8.16	54	40.46	32.16	7.4	34.18	226	14	A	H
		2462	101.76	-29.54	131.3	96.46	32.11	7.4	34.21	108	6	P	V
		2462	94.08	-37.22	131.3	88.78	32.11	7.4	34.21	108	6	A	V
		2483.6	61.6	-12.4	74	56.22	32.16	7.4	34.18	108	6	P	V
		2483.56	46.71	-7.29	54	41.33	32.16	7.4	34.18	108	6	A	V
Remark	1. No other spurious found. 2. All results are PASS against Peak and Average limit line.												



2.4GHz 2400~2483.5MHz

WIFI 802.11n HT20 (Harmonic @ 3m)

WIFI Ant. 1	Note	Frequency (MHz)	Level (dBμV/m)	Over Limit (dB)	Limit Line (dBμV/m)	Read Level (dBμV)	Antenna Factor (dB/m)	Cable Loss (dB)	Preamp Factor (dB)	Ant Pos (cm)	Table Pos (deg)	Peak Avg. (P/A)	Pol. (H/V)
802.11n HT20 CH 01 2412MHz		4824	40.32	-33.68	74	53.48	34.2	11.68	59.04	100	0	P	H
		4824	40.6	-33.4	74	53.76	34.2	11.68	59.04	100	0	P	V
802.11n HT20 CH 06 2437MHz		4872	39.96	-34.04	74	53.14	34.23	11.53	58.94	100	0	P	H
		7308	39.94	-34.06	74	48.46	35.6	13.81	57.93	100	0	P	H
		4872	39.49	-34.51	74	52.67	34.23	11.53	58.94	100	0	P	V
		7308	40.22	-33.78	74	48.74	35.6	13.81	57.93	100	0	P	V
802.11n HT20 CH 11 2462MHz		4926	39.82	-34.18	74	53.03	34.26	11.37	58.84	100	0	P	H
		7386	39.89	-34.11	74	48.4	35.6	13.95	58.06	100	0	P	H
		4926	39.55	-34.45	74	52.76	34.26	11.37	58.84	100	0	P	V
		7386	40.05	-33.95	74	48.56	35.6	13.95	58.06	100	0	P	V
Remark	1. No other spurious found. 2. All results are PASS against Peak and Average limit line.												



2.4GHz 2400~2483.5MHz

Emission below 1GHz

2.4GHz WIFI 802.11g (LF)

WIFI Ant.	Note	Frequency	Level	Over Limit	Limit Line	Read Level	Antenna Factor	Cable Loss	Preamp Factor	Ant Pos	Table Pos	Peak Avg.	Pol.
1		(MHz)	(dBμV/m)	(dB)	(dBμV/m)	(dBμV)	(dB/m)	(dB)	(dB)	(cm)	(deg)	(P/A)	(H/V)
2.4GHz 802.11g LF		30	27.71	-12.29	40	31.99	26	1.07	31.35	100	0	P	H
		127.74	20.36	-23.14	43.5	32.1	18.22	1.55	31.51			P	H
		256.8	21.73	-24.27	46	31.32	19.7	2.07	31.36			P	H
		449.8	26.23	-19.77	46	31.34	23.1	2.89	31.1			P	H
		712.3	29.76	-16.24	46	30.13	26.59	3.74	30.7			P	H
		994.4	34.65	-19.35	54	30.9	30.29	3.98	30.52			P	H
		30.27	27.18	-12.82	40	31.46	26	1.07	31.35			P	V
		133.14	19.78	-23.72	43.5	31.53	18.21	1.55	31.51			P	V
		259.23	21.83	-24.17	46	31.22	19.9	2.07	31.36			P	V
		538	27.03	-18.97	46	30.32	24.51	3.14	30.94			P	V
		768.3	30.96	-15.04	46	30.39	27.38	3.82	30.63			P	V
	946.1	34.34	-11.66	46	30.69	30.11	4.07	30.53	100	0	P	V	
Remark	1. No other spurious found. 2. All results are PASS against limit line.												



Note symbol

*	Fundamental Frequency which can be ignored. However, the level of any unwanted emissions shall not exceed the level of the fundamental frequency.
!	Test result is over limit line.
P/A	Peak or Average
H/V	Horizontal or Vertical



A calculation example for radiated spurious emission is shown as below:

WIFI	Note	Frequency	Level	Over	Limit	Read	Antenna	Cable	Preamp	Ant	Table	Peak	Pol.
Ant.				Limit	Line	Level	Factor	Loss	Factor	Pos	Pos	Avg.	
1		(MHz)	(dBμV/m)	(dB)	(dBμV/m)	(dBμV)	(dB/m)	(dB)	(dB)	(cm)	(deg)	(P/A)	(H/V)
802.11b		2390	55.45	-18.55	74	54.51	32.22	4.58	35.86	103	308	P	H
CH 01													
2412MHz		2390	43.54	-10.46	54	42.6	32.22	4.58	35.86	103	308	A	H

- Level(dBμV/m) =
Antenna Factor(dB/m) + Cable Loss(dB) + Read Level(dBμV) - Preamp Factor(dB)
- Over Limit(dB) = Level(dBμV/m) – Limit Line(dBμV/m)

For Peak Limit @ 2390MHz:

- Level(dBμV/m)
= Antenna Factor(dB/m) + Cable Loss(dB) + Read Level(dBμV) - Preamp Factor(dB)
= 32.22(dB/m) + 4.58(dB) + 54.51(dBμV) – 35.86 (dB)
= 55.45 (dBμV/m)
- Over Limit(dB)
= Level(dBμV/m) – Limit Line(dBμV/m)
= 55.45(dBμV/m) – 74(dBμV/m)
= -18.55(dB)

For Average Limit @ 2390MHz:

- Level(dBμV/m)
= Antenna Factor(dB/m) + Cable Loss(dB) + Read Level(dBμV) - Preamp Factor(dB)
= 32.22(dB/m) + 4.58(dB) + 42.6(dBμV) – 35.86 (dB)
= 43.54 (dBμV/m)
- Over Limit(dB)
= Level(dBμV/m) – Limit Line(dBμV/m)
= 43.54(dBμV/m) – 54(dBμV/m)
= -10.46(dB)

Both peak and average measured complies with the limit line, so test result is “PASS”.



Appendix C. Radiated Spurious Emission Plots

Test Engineer :	Luke Chang, Jesse Wang, Derreck Chen,	Temperature :	21~23°C
	James Chiu	Relative Humidity :	60~63%

Note symbol

-L	Low channel location
-R	High channel location



2.4GHz 2400~2483.5MHz
WIFI 802.11b (Band Edge @ 3m)

WIFI	2.4GHz 2400~2483.5MHz Band Edge @ 3m	
ANT	802.11b CH01 2412MHz	
1	Horizontal	Fundamental
Peak	<p>Site : 03CH07.HY Condition : 15.209(PEAK) 3m HF-ANT_130829 HORIZONTAL RBW:1000.000kHz VBW:3000.000kHz SWT:Auto Detector : Peak</p>	<p>Site : 03CH07.HY Condition : 15.209(PEAK) 3m HF-ANT_130829 HORIZONTAL RBW:1000.000kHz VBW:3000.000kHz SWT:Auto Detector : Peak</p>
Avg.	<p>Site : 03CH07.HY Condition : 15.209(AVG) 3m HF-ANT_130829 HORIZONTAL RBW:1000.000kHz VBW:0.300kHz SWT:Auto Detector : Peak</p>	<p>Site : 03CH07.HY Condition : 15.209(AVG) 3m HF-ANT_130829 HORIZONTAL RBW:1000.000kHz VBW:0.300kHz SWT:Auto Detector : Peak</p>



WIFI	2.4GHz 2400~2483.5MHz Band Edge @ 3m	
ANT	802.11b CH01 2412MHz	
1	Vertical	Fundamental
Peak	<p> Date: 2016-07-24 15.209(PEAK) </p> <p> Site : 03CH07-HY Condition : 15.209(PEAK) 3m HF-ANT_130829 VERTICAL RBW: 1000.000kHz VBW:3000.000kHz SWT:Auto Detector : Peak </p>	<p> Date: 2016-07-24 15.209(PEAK) </p> <p> Site : 03CH07-HY Condition : 15.209(PEAK) 3m HF-ANT_130829 VERTICAL RBW: 1000.000kHz VBW:3000.000kHz SWT:Auto Detector : Peak </p>
Avg.	<p> Date: 2016-07-24 15.209(AVG) </p> <p> Site : 03CH07-HY Condition : 15.209(AVG) 3m HF-ANT_130829 VERTICAL RBW: 1000.000kHz VBW:0.300kHz SWT:Auto Detector : Peak </p>	<p> Date: 2016-07-24 15.209(AVG) </p> <p> Site : 03CH07-HY Condition : 15.209(AVG) 3m HF-ANT_130829 VERTICAL RBW: 1000.000kHz VBW:0.300kHz SWT:Auto Detector : Peak </p>



WIFI	2.4GHz 2400~2483.5MHz Band Edge @ 3m	
ANT	802.11b CH06 2437MHz - L	
1	Horizontal	Fundamental
Peak	<p>Site : 03CH07-HY Condition : 15.209(PEAK) 3m HF-ANT_130829 HORIZONTAL Detector : Peak</p>	<p>Site : 03CH07-HY Condition : 15.209(PEAK) 3m HF-ANT_130829 HORIZONTAL Detector : Peak</p>
Avg.	<p>Site : 03CH07-HY Condition : 15.289(AVG) 3m HF-ANT_130829 HORIZONTAL Detector : Peak</p>	<p>Site : 03CH07-HY Condition : 15.209(AVG) 3m HF-ANT_130829 HORIZONTAL Detector : Peak</p>



WIFI	2.4GHz 2400~2483.5MHz Band Edge @ 3m	
ANT	802.11b CH06 2437MHz - R	
1	Horizontal	Fundamental
Peak	<p>Site : 03CH07.HY Condition : 15.209(PEAK) 3m HF-ANT_130829 HORIZONTAL RBW: 1000.000kHz VBW:3000.000kHz SWT:Auto Detector : Peak</p>	Left blank
Avg.	<p>Site : 03CH07.HY Condition : 15.209(AVG) 3m HF-ANT_130829 HORIZONTAL RBW: 1000.000kHz VBW:0.300kHz SWT:Auto Detector : Peak</p>	Left blank



WIFI	2.4GHz 2400~2483.5MHz Band Edge @ 3m	
ANT	802.11b CH06 2437MHz - L	
1	Vertical	Fundamental
Peak	<p> Date: 2016-07-24 Level: 15.209(PEAK) Site : 03CH07-HY Condition : 15.209(PEAK) 3m HF-ANT_130829 VERTICAL RBW: 1000.000kHz VBW:3000.000kHz SWT:Auto Detector : Peak </p>	<p> Date: 2016-07-24 Level: 15.209(PEAK) Site : 03CH07-HY Condition : 15.209(PEAK) 3m HF-ANT_130829 VERTICAL RBW: 1000.000kHz VBW:3000.000kHz SWT:Auto Detector : Peak </p>
Avg.	<p> Date: 2016-07-24 Level: 15.209(AVG) Site : 03CH07-HY Condition : 15.209(AVG) 3m HF-ANT_130829 VERTICAL RBW: 1000.000kHz VBW:3000.000kHz SWT:Auto Detector : Peak </p>	<p> Date: 2016-07-24 Level: 15.209(AVG) Site : 03CH07-HY Condition : 15.209(AVG) 3m HF-ANT_130829 VERTICAL RBW: 1000.000kHz VBW:3000.000kHz SWT:Auto Detector : Peak </p>

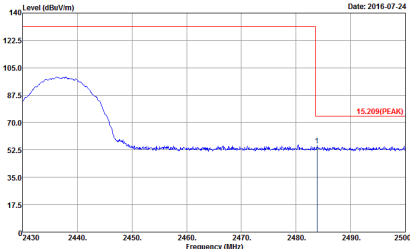
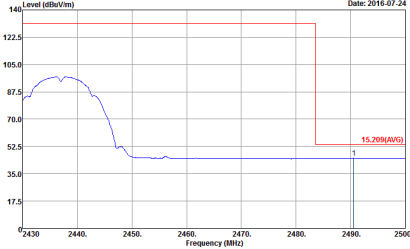

WIFI	2.4GHz 2400~2483.5MHz Band Edge @ 3m	
ANT	802.11b CH06 2437MHz - R	
1	Vertical	Fundamental
Peak	 <p>Date: 2016-07-24</p> <p>Site : 03CH074YY Condition : 15.209(PEAK) 3m HF-ANT_130829 VERTICAL RBW: 1000.000kHz VBW: 3000.000kHz SWT: Auto Detector : Peak</p>	Left blank
Avg.	 <p>Date: 2016-07-24</p> <p>Site : 03CH074YY Condition : 15.209(AVG) 3m HF-ANT_130829 VERTICAL RBW: 1000.000kHz VBW: 3000.000kHz SWT: Auto Detector : Peak</p>	Left blank



WIFI	2.4GHz 2400~2483.5MHz Band Edge @ 3m	
ANT	802.11b CH11 2462MHz	
1	Horizontal	Fundamental
Peak	<p>Level (dBuV/m) vs Frequency (MHz) graph for Horizontal antenna. The y-axis ranges from 17.5 to 140 dBuV/m, and the x-axis ranges from 2460 to 2500 MHz. A peak is observed at 15.209(MPEAK) dBuV/m. The graph shows a blue line representing the signal level, which starts at approximately 87.5 dBuV/m at 2460 MHz and drops to about 52.5 dBuV/m by 2475 MHz. A red box highlights the peak at 15.209(MPEAK) dBuV/m.</p> <p>Site : 03CH07-HY Condition : 15.209(MPEAK) 3m HF-ANT_130829 HORIZONTAL RBW: 1000.000kHz VBW:3000.000kHz SWT:Auto Detector : Peak</p>	<p>Level (dBuV/m) vs Frequency (MHz) graph for Fundamental antenna. The y-axis ranges from 17.5 to 140 dBuV/m, and the x-axis ranges from 1000 to 3000 MHz. A peak is observed at 15.209(MPEAK) dBuV/m. The graph shows a blue line representing the signal level, which is relatively flat around 52.5 dBuV/m until approximately 2450 MHz, where it rises sharply to the peak at 15.209(MPEAK) dBuV/m. A red box highlights the peak.</p> <p>Site : 03CH07-HY Condition : 15.209(MPEAK) 3m HF-ANT_130829 HORIZONTAL RBW: 1000.000kHz VBW:3000.000kHz SWT:Auto Detector : Peak</p>
Avg.	<p>Level (dBuV/m) vs Frequency (MHz) graph for Horizontal antenna. The y-axis ranges from 17.5 to 140 dBuV/m, and the x-axis ranges from 2460 to 2500 MHz. A peak is observed at 15.209(AVG) dBuV/m. The graph shows a blue line representing the signal level, which starts at approximately 87.5 dBuV/m at 2460 MHz and drops to about 52.5 dBuV/m by 2475 MHz. A red box highlights the peak at 15.209(AVG) dBuV/m.</p> <p>Site : 03CH07-HY Condition : 15.209(AVG) 3m HF-ANT_130829 HORIZONTAL RBW: 1000.000kHz VBW:0.300kHz SWT:Auto Detector : Peak</p>	<p>Level (dBuV/m) vs Frequency (MHz) graph for Fundamental antenna. The y-axis ranges from 17.5 to 140 dBuV/m, and the x-axis ranges from 1000 to 3000 MHz. A peak is observed at 15.209(AVG) dBuV/m. The graph shows a blue line representing the signal level, which is relatively flat around 52.5 dBuV/m until approximately 2450 MHz, where it rises sharply to the peak at 15.209(AVG) dBuV/m. A red box highlights the peak.</p> <p>Site : 03CH07-HY Condition : 15.209(AVG) 3m HF-ANT_130829 HORIZONTAL RBW: 1000.000kHz VBW:0.300kHz SWT:Auto Detector : Peak</p>



WIFI	2.4GHz 2400~2483.5MHz Band Edge @ 3m	
ANT	802.11b CH11 2462MHz	
1	Vertical	Fundamental
Peak	<p>Level (dBuV/m) vs Frequency (MHz) graph for Vertical antenna. The y-axis ranges from 17.5 to 140 dBuV/m, and the x-axis ranges from 2450 to 2500 MHz. A peak is observed at 2462 MHz with a level of 15.209 dBuV/m. The graph shows a noise floor that decreases from approximately 90 dBuV/m at 2450 MHz to about 55 dBuV/m at 2462 MHz, then remains relatively flat.</p> <p>Site : 03CH07-HY Condition : 15.209(PEAK) 3m HF-ANT_130829 VERTICAL RBW: 1000.000kHz VBW:3000.000kHz SWT:Auto Detector : Peak</p>	<p>Level (dBuV/m) vs Frequency (MHz) graph for Fundamental antenna. The y-axis ranges from 17.5 to 140 dBuV/m, and the x-axis ranges from 1000 to 3000 MHz. A sharp peak is observed at 2462 MHz with a level of 15.209 dBuV/m. The noise floor is significantly lower than in the vertical graph, around 55 dBuV/m.</p> <p>Site : 03CH07-HY Condition : 15.209(PEAK) 3m HF-ANT_130829 VERTICAL RBW: 1000.000kHz VBW:3000.000kHz SWT:Auto Detector : Peak</p>
Avg.	<p>Level (dBuV/m) vs Frequency (MHz) graph for Vertical antenna (Average). The y-axis ranges from 17.5 to 140 dBuV/m, and the x-axis ranges from 2450 to 2500 MHz. A peak is observed at 2462 MHz with a level of 15.209 dBuV/m. The noise floor is smoother than in the peak graph.</p> <p>Site : 03CH07-HY Condition : 15.209(AVG) 3m HF-ANT_130829 VERTICAL RBW: 1000.000kHz VBW:0.300kHz SWT:Auto Detector : Peak</p>	<p>Level (dBuV/m) vs Frequency (MHz) graph for Fundamental antenna (Average). The y-axis ranges from 17.5 to 140 dBuV/m, and the x-axis ranges from 1000 to 3000 MHz. A sharp peak is observed at 2462 MHz with a level of 15.209 dBuV/m. The noise floor is very low and flat across the frequency range.</p> <p>Site : 03CH07-HY Condition : 15.209(AVG) 3m HF-ANT_130829 VERTICAL RBW: 1000.000kHz VBW:0.300kHz SWT:Auto Detector : Peak</p>



2.4GHz 2400~2483.5MHz
WIFI 802.11g (Band Edge @ 3m)

WIFI	2.4GHz 2400~2483.5MHz Band Edge @ 3m	
ANT	802.11g CH01 2412MHz	
1	Horizontal	Fundamental
Peak	<p>Site : 03CH07.HY Condition : 15.209(Peak) 3m HF-ANT_130829 HORIZONTAL RBW:1000.000kHz VBW:3000.000kHz SWT:Auto Detector : Peak</p>	<p>Site : 03CH07.HY Condition : 15.209(Peak) 3m HF-ANT_130829 HORIZONTAL RBW:1000.000kHz VBW:3000.000kHz SWT:Auto Detector : Peak</p>
Avg.	<p>Site : 03CH07.HY Condition : 15.209(Avg) 3m HF-ANT_130829 HORIZONTAL RBW:1000.000kHz VBW:1.000kHz SWT:Auto Detector : Peak</p>	<p>Site : 03CH07.HY Condition : 15.209(Avg) 3m HF-ANT_130829 HORIZONTAL RBW:1000.000kHz VBW:1.000kHz SWT:Auto Detector : Peak</p>



WIFI	2.4GHz 2400~2483.5MHz Band Edge @ 3m	
ANT	802.11g CH01 2412MHz	
1	Vertical	Fundamental
Peak	<p>Level (dBuV/m) vs Frequency (MHz) plot. The y-axis ranges from 17.5 to 140 dBuV/m. The x-axis ranges from 2310 to 2415 MHz. A sharp peak is observed at 2412 MHz, reaching a level of 15.209(PK). The date is 2016-07-24.</p> <p>Site : 03CH07-HY Condition : 15.209(PK) 3m HF-ANT_130829 VERTICAL RBW: 1000.000kHz VBW: 3000.000kHz SWT: Auto Detector : Peak</p>	<p>Level (dBuV/m) vs Frequency (MHz) plot. The y-axis ranges from 17.5 to 140 dBuV/m. The x-axis ranges from 1000 to 3000 MHz. A sharp peak is observed at 2412 MHz, reaching a level of 15.209(PK). The date is 2016-07-24.</p> <p>Site : 03CH07-HY Condition : 15.209(PK) 3m HF-ANT_130829 VERTICAL RBW: 1000.000kHz VBW: 3000.000kHz SWT: Auto Detector : Peak</p>
Avg.	<p>Level (dBuV/m) vs Frequency (MHz) plot. The y-axis ranges from 17.5 to 140 dBuV/m. The x-axis ranges from 2310 to 2415 MHz. A sharp peak is observed at 2412 MHz, reaching a level of 15.209(AVG). The date is 2016-07-24.</p> <p>Site : 03CH07-HY Condition : 15.209(AVG) 3m HF-ANT_130829 VERTICAL RBW: 1000.000kHz VBW: 1.000kHz SWT: Auto Detector : Peak</p>	<p>Level (dBuV/m) vs Frequency (MHz) plot. The y-axis ranges from 17.5 to 140 dBuV/m. The x-axis ranges from 1000 to 3000 MHz. A sharp peak is observed at 2412 MHz, reaching a level of 15.209(AVG). The date is 2016-07-24.</p> <p>Site : 03CH07-HY Condition : 15.209(AVG) 3m HF-ANT_130829 VERTICAL RBW: 1000.000kHz VBW: 1.000kHz SWT: Auto Detector : Peak</p>



WIFI	2.4GHz 2400~2483.5MHz Band Edge @ 3m	
ANT	802.11g CH06 2437MHz - L	
1	Horizontal	Fundamental
Peak	<p>Site : 03CH07-HY Condition : 15.209(PEAK) 3m HF-ANT_130829 HORIZONTAL RBW:1000.000kHz VBW:3000.000kHz SWT:Auto Detector : Peak</p>	<p>Site : 03CH07-HY Condition : 15.209(PEAK) 3m HF-ANT_130829 HORIZONTAL RBW:1000.000kHz VBW:3000.000kHz SWT:Auto Detector : Peak</p>
Avg.	<p>Site : 03CH07-HY Condition : 15.209(AVG) 3m HF-ANT_130829 HORIZONTAL RBW:1000.000kHz VBW:1.000kHz SWT:Auto Detector : Peak</p>	<p>Site : 03CH07-HY Condition : 15.209(AVG) 3m HF-ANT_130829 HORIZONTAL RBW:1000.000kHz VBW:1.000kHz SWT:Auto Detector : Peak</p>



WIFI	2.4GHz 2400~2483.5MHz Band Edge @ 3m	
ANT	802.11g CH06 2437MHz - R	
1	Horizontal	Fundamental
Peak	<p>Level (dBuV/m)</p> <p>Date: 2016-07-24</p> <p>15.209(PK)</p> <p>Frequency (MHz)</p> <p>Site : 03CH07-1Y Condition : 15.209(PK) 3m HF-ANT_130829 HORIZONTAL RBW: 1000.000kHz VBW: 3000.000kHz SWT: Auto Detector : Peak</p>	Left blank
Avg.	<p>Level (dBuV/m)</p> <p>Date: 2016-07-24</p> <p>15.209(AVG)</p> <p>Frequency (MHz)</p> <p>Site : 03CH07-1Y Condition : 15.209(AVG) 3m HF-ANT_130829 HORIZONTAL RBW: 1000.000kHz VBW: 1.000kHz SWT: Auto Detector : Peak</p>	Left blank

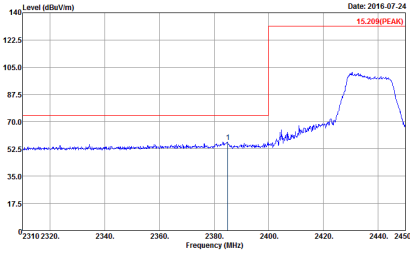
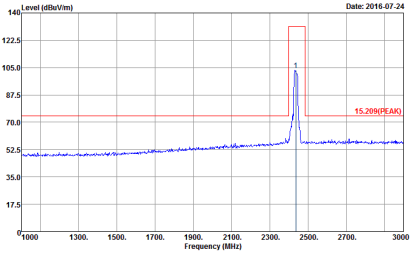
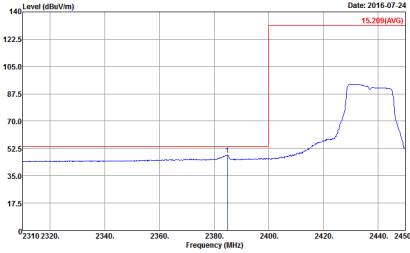
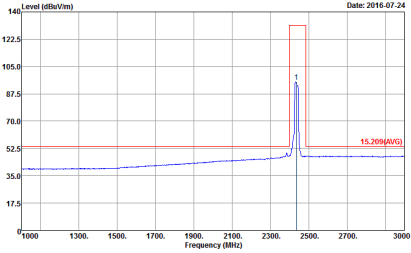

WIFI	2.4GHz 2400~2483.5MHz Band Edge @ 3m	
ANT	802.11g CH06 2437MHz - L	
1	Vertical	Fundamental
Peak	 <p>Date: 2016-07-24 15.209(PEAK)</p> <p>Site : 03CH07.HY Condition : 15.209(PEAK) 3m HF-ANT_130829 VERTICAL RBW: 1000.000kHz VBW: 3000.000kHz SWT: Auto Detector : Peak</p>	 <p>Date: 2016-07-24 15.209(PEAK)</p> <p>Site : 03CH07.HY Condition : 15.209(PEAK) 3m HF-ANT_130829 VERTICAL RBW: 1000.000kHz VBW: 3000.000kHz SWT: Auto Detector : Peak</p>
Avg.	 <p>Date: 2016-07-24 15.209(AVG)</p> <p>Site : 03CH07.HY Condition : 15.209(AVG) 3m HF-ANT_130829 VERTICAL RBW: 1000.000kHz VBW: 1.000kHz SWT: Auto Detector : Peak</p>	 <p>Date: 2016-07-24 15.209(AVG)</p> <p>Site : 03CH07.HY Condition : 15.209(AVG) 3m HF-ANT_130829 VERTICAL RBW: 1000.000kHz VBW: 1.000kHz SWT: Auto Detector : Peak</p>



WIFI	2.4GHz 2400~2483.5MHz Band Edge @ 3m	
ANT	802.11g CH06 2437MHz - R	
1	Vertical	Fundamental
Peak	<p>Level (dBuV/m)</p> <p>Frequency (MHz)</p> <p>Date: 2016.07.24</p> <p>15.209(PEAK)</p> <p>Site : 03CH07-HY Condition : 15.209(PEAK) 3m HF-ANT_130829 VERTICAL RBW: 1000.000kHz VBW: 3000.000kHz SWT: Auto Detector : Peak</p>	Left Blank
Avg.	<p>Level (dBuV/m)</p> <p>Frequency (MHz)</p> <p>Date: 2016.07.24</p> <p>15.209(AVG)</p> <p>Site : 03CH07-HY Condition : 15.209(AVG) 3m HF-ANT_130829 VERTICAL RBW: 1000.000kHz VBW: 1.000kHz SWT: Auto Detector : Peak</p>	Left Blank



WIFI	2.4GHz 2400~2483.5MHz Band Edge @ 3m	
ANT	802.11g CH11 2462MHz	
1	Horizontal	Fundamental
Peak	<p>Level (dBuV/m) vs Frequency (MHz) graph for Horizontal orientation. The signal level is 15.209 dBm at 2462 MHz. The y-axis ranges from 0 to 140 dBuV/m, and the x-axis ranges from 2460 to 2500 MHz.</p> <p>Site : 03CH07.HY Condition : 15.209(PEAK) 3m HF-ANT_130829 HORIZONTAL RBW:1000.000kHz VBW:3000.000kHz SWT:Auto Detector : Peak</p>	<p>Level (dBuV/m) vs Frequency (MHz) graph for Fundamental orientation. The signal level is 15.209 dBm at 2462 MHz. The y-axis ranges from 0 to 140 dBuV/m, and the x-axis ranges from 1000 to 3000 MHz.</p> <p>Site : 03CH07.HY Condition : 15.209(PEAK) 3m HF-ANT_130829 HORIZONTAL RBW:1000.000kHz VBW:3000.000kHz SWT:Auto Detector : Peak</p>
Avg.	<p>Level (dBuV/m) vs Frequency (MHz) graph for Horizontal orientation. The signal level is 15.209 dBm at 2462 MHz. The y-axis ranges from 0 to 140 dBuV/m, and the x-axis ranges from 2460 to 2500 MHz.</p> <p>Site : 03CH07.HY Condition : 15.209(AVG) 3m HF-ANT_130829 HORIZONTAL RBW:1000.000kHz VBW:1.000kHz SWT:Auto Detector : Peak</p>	<p>Level (dBuV/m) vs Frequency (MHz) graph for Fundamental orientation. The signal level is 15.209 dBm at 2462 MHz. The y-axis ranges from 0 to 140 dBuV/m, and the x-axis ranges from 1000 to 3000 MHz.</p> <p>Site : 03CH07.HY Condition : 15.209(AVG) 3m HF-ANT_130829 HORIZONTAL RBW:1000.000kHz VBW:1.000kHz SWT:Auto Detector : Peak</p>



WIFI	2.4GHz 2400~2483.5MHz Band Edge @ 3m	
ANT	802.11g CH11 2462MHz	
1	Vertical	Fundamental
Peak	<p>Level (dBuV/m) vs Frequency (MHz) plot for Vertical antenna. The plot shows a peak at 2462 MHz with a level of 15.209(PK). The x-axis ranges from 2460 to 2500 MHz, and the y-axis ranges from 17.5 to 140 dBuV/m.</p> <p>Site : 03CH07-HY Condition : 15.209(PK) 3m HF-ANT_130829 VERTICAL RBW: 1000.000kHz VBW:3000.000kHz SWT:Auto Detector : Peak</p>	<p>Level (dBuV/m) vs Frequency (MHz) plot for Fundamental antenna. The plot shows a peak at 2462 MHz with a level of 15.209(PK). The x-axis ranges from 1000 to 3000 MHz, and the y-axis ranges from 17.5 to 140 dBuV/m.</p> <p>Site : 03CH07-HY Condition : 15.209(PK) 3m HF-ANT_130829 VERTICAL RBW: 1000.000kHz VBW:3000.000kHz SWT:Auto Detector : Peak</p>
Avg.	<p>Level (dBuV/m) vs Frequency (MHz) plot for Vertical antenna. The plot shows a peak at 2462 MHz with a level of 15.209(AVG). The x-axis ranges from 2460 to 2500 MHz, and the y-axis ranges from 17.5 to 140 dBuV/m.</p> <p>Site : 03CH07-HY Condition : 15.209(AVG) 3m HF-ANT_130829 VERTICAL RBW: 1000.000kHz VBW:1.000kHz SWT:Auto Detector : Peak</p>	<p>Level (dBuV/m) vs Frequency (MHz) plot for Fundamental antenna. The plot shows a peak at 2462 MHz with a level of 15.209(AVG). The x-axis ranges from 1000 to 3000 MHz, and the y-axis ranges from 17.5 to 140 dBuV/m.</p> <p>Site : 03CH07-HY Condition : 15.209(AVG) 3m HF-ANT_130829 VERTICAL RBW: 1000.000kHz VBW:1.000kHz SWT:Auto Detector : Peak</p>



2.4GHz 2400~2483.5MHz
WIFI 802.11n HT20 (Band Edge @ 3m)

WIFI	2.4GHz 2400~2483.5MHz Band Edge @ 3m	
ANT	802.11n HT20 CH01 2412MHz	
1	Horizontal	Fundamental
Peak	<p>Site : 03CH07.HY Condition : 15.209(PEAK) 3m HF-ANT_130829 HORIZONTAL Detector : Peak</p>	<p>Site : 03CH07.HY Condition : 15.209(PEAK) 3m HF-ANT_130829 HORIZONTAL Detector : Peak</p>
Avg.	<p>Site : 03CH07.HY Condition : 15.209(AVG) 3m HF-ANT_130829 HORIZONTAL Detector : Peak</p>	<p>Site : 03CH07.HY Condition : 15.209(AVG) 3m HF-ANT_130829 HORIZONTAL Detector : Peak</p>



WIFI	2.4GHz 2400~2483.5MHz Band Edge @ 3m	
ANT	802.11n HT20 CH01 2412MHz	
1	Vertical	Fundamental
Peak	<p>Site : 03CH07-HY Condition : 15.209(PEAK) 3m HF-ANT_130829 VERTICAL RBW: 1000.000kHz VBW: 3000.000kHz SWT: Auto Detector : Peak</p>	<p>Site : 03CH07-HY Condition : 15.209(PEAK) 3m HF-ANT_130829 VERTICAL RBW: 1000.000kHz VBW: 3000.000kHz SWT: Auto Detector : Peak</p>
Avg.	<p>Site : 03CH07-HY Condition : 15.209(AVG) 3m HF-ANT_130829 VERTICAL RBW: 1000.000kHz VBW: 1.000kHz SWT: Auto Detector : Peak</p>	<p>Site : 03CH07-HY Condition : 15.209(AVG) 3m HF-ANT_130829 VERTICAL RBW: 1000.000kHz VBW: 1.000kHz SWT: Auto Detector : Peak</p>



WIFI	2.4GHz 2400~2483.5MHz Band Edge @ 3m	
ANT	802.11n HT20 CH06 2437MHz - L	
1	Horizontal	Fundamental
Peak	<p>Site : 03CH07-HY Condition : 15.209(PEAK) 3m HF-ANT_130829 HORIZONTAL RBW: 1000.000kHz VBW:3000.000kHz SWT:Auto Detector : Peak</p>	<p>Site : 03CH07-HY Condition : 15.209(PEAK) 3m HF-ANT_130829 HORIZONTAL RBW: 1000.000kHz VBW:3000.000kHz SWT:Auto Detector : Peak</p>
Avg.	<p>Site : 03CH07-HY Condition : 15.209(AVG) 3m HF-ANT_130829 HORIZONTAL RBW: 1000.000kHz VBW:1.000kHz SWT:Auto Detector : Peak</p>	<p>Site : 03CH07-HY Condition : 15.209(AVG) 3m HF-ANT_130829 HORIZONTAL RBW: 1000.000kHz VBW:1.000kHz SWT:Auto Detector : Peak</p>



WIFI	2.4GHz 2400~2483.5MHz Band Edge @ 3m	
ANT	802.11n HT20 CH06 2437MHz - R	
1	Horizontal	Fundamental
Peak	<p>Site : 03CH07.HY Condition : 15.209(PEAK) 3m HF-ANT_130829 HORIZONTAL RBW: 1000.000kHz VBW: 3000.000kHz SWT: Auto Detector : Peak</p>	Left blank
Avg.	<p>Site : 03CH07.HY Condition : 15.209(AVG) 3m HF-ANT_130829 HORIZONTAL RBW: 1000.000kHz VBW: 1.000kHz SWT: Auto Detector : Peak</p>	Left blank



WIFI	2.4GHz 2400~2483.5MHz Band Edge @ 3m	
ANT	802.11n HT20 CH06 2437MHz - L	
1	Vertical	Fundamental
Peak	<p>Level (dBm/Vm) vs Frequency (MHz) plot for Peak Vertical. The plot shows a signal level of 15.209 dBm (PEAK) at 2437 MHz. The x-axis ranges from 2310 to 2450 MHz, and the y-axis ranges from 17.5 to 140 dBm/Vm.</p> <p>Site : 03CH07-HY Condition : 15.209(PEAK) 3m HF-ANT_130829 VERTICAL RBW:1000.000kHz VBW:3000.000kHz SWT:Auto Detector : Peak</p>	<p>Level (dBm/Vm) vs Frequency (MHz) plot for Peak Fundamental. The plot shows a signal level of 15.209 dBm (PEAK) at 2437 MHz. The x-axis ranges from 1000 to 3000 MHz, and the y-axis ranges from 17.5 to 140 dBm/Vm.</p> <p>Site : 03CH07-HY Condition : 15.209(PEAK) 3m HF-ANT_130829 VERTICAL RBW:1000.000kHz VBW:3000.000kHz SWT:Auto Detector : Peak</p>
Avg.	<p>Level (dBm/Vm) vs Frequency (MHz) plot for Avg Vertical. The plot shows an average signal level of 15.209 dBm (AVG) at 2437 MHz. The x-axis ranges from 2310 to 2450 MHz, and the y-axis ranges from 17.5 to 140 dBm/Vm.</p> <p>Site : 03CH07-HY Condition : 15.209(AVG) 3m HF-ANT_130829 VERTICAL RBW:1000.000kHz VBW:1.000kHz SWT:Auto Detector : Peak</p>	<p>Level (dBm/Vm) vs Frequency (MHz) plot for Avg Fundamental. The plot shows an average signal level of 15.209 dBm (AVG) at 2437 MHz. The x-axis ranges from 1000 to 3000 MHz, and the y-axis ranges from 17.5 to 140 dBm/Vm.</p> <p>Site : 03CH07-HY Condition : 15.209(AVG) 3m HF-ANT_130829 VERTICAL RBW:1000.000kHz VBW:1.000kHz SWT:Auto Detector : Peak</p>

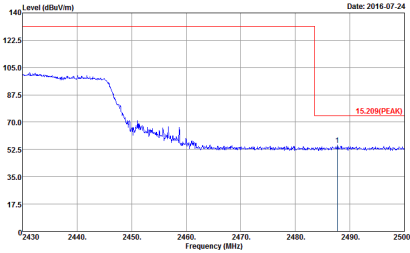
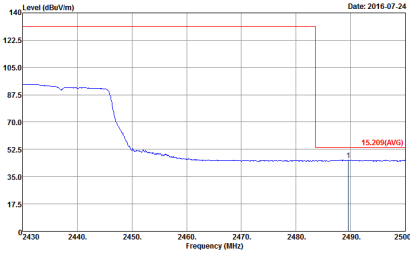

WIFI	2.4GHz 2400~2483.5MHz Band Edge @ 3m	
ANT	802.11n HT20 CH06 2437MHz - R	
1	Vertical	Fundamental
Peak	 <p>Date: 2016-07-24</p> <p>Level (dBuV/m)</p> <p>Frequency (MHz)</p> <p>15.209(PK)</p> <p>Site : 03CH074Y Condition : 15.209(PK) 3m HF-ANT_130829 VERTICAL RBW: 1000.000kHz VBW: 3000.000kHz SWT: Auto Detector : Peak</p>	Left Blank
Avg.	 <p>Date: 2016-07-24</p> <p>Level (dBuV/m)</p> <p>Frequency (MHz)</p> <p>15.209(AVG)</p> <p>Site : 03CH074Y Condition : 15.209(AVG) 3m HF-ANT_130829 VERTICAL RBW: 1000.000kHz VBW: 1.000kHz SWT: Auto Detector : Peak</p>	Left Blank

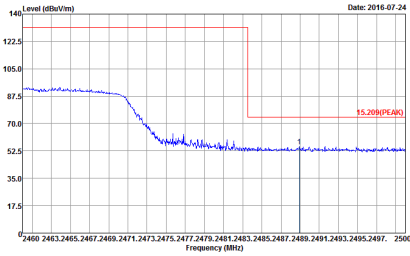
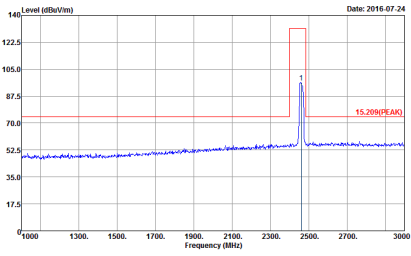
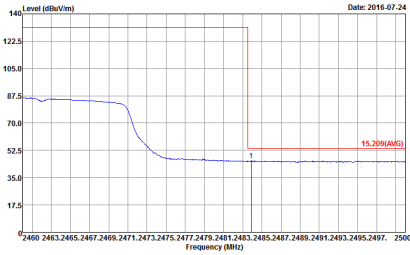
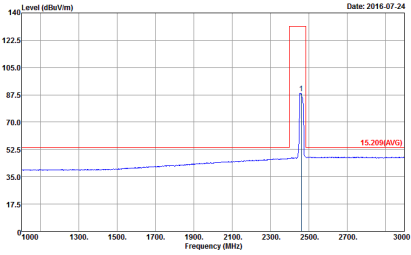

WIFI	2.4GHz 2400~2483.5MHz Band Edge @ 3m	
ANT	802.11n HT20 CH11 2462MHz	
1	Horizontal	Fundamental
Peak	 <p>Site : 03CH07.HY Condition : 15.209(PEAK) 3m HF-ANT_130829 HORIZONTAL RBW:1000.000kHz VSW:3000.000kHz SWT:Auto Detector : Peak</p>	 <p>Site : 03CH07.HY Condition : 15.209(PEAK) 3m HF-ANT_130829 HORIZONTAL RBW:1000.000kHz VSW:3000.000kHz SWT:Auto Detector : Peak</p>
Avg.	 <p>Site : 03CH07.HY Condition : 15.209(AVG) 3m HF-ANT_130829 HORIZONTAL RBW:1000.000kHz VSW:1.000kHz SWT:Auto Detector : Peak</p>	 <p>Site : 03CH07.HY Condition : 15.209(AVG) 3m HF-ANT_130829 HORIZONTAL RBW:1000.000kHz VSW:1.000kHz SWT:Auto Detector : Peak</p>



WIFI	2.4GHz 2400~2483.5MHz Fundamental @ 3m	
ANT	802.11n HT20 CH11 2462MHz	
1	Vertical	Fundamental
Peak	<p>Level (dBuV/m) vs Frequency (MHz) plot for Vertical antenna. The plot shows a signal level of 15.209 dBm (PEAK) at 2462 MHz. The y-axis ranges from 17.5 to 140 dBuV/m, and the x-axis ranges from 2460 to 2500 MHz. A red box highlights the peak at 2462 MHz.</p> <p>Site : 03CH07-HY Condition : 15.209(PEAK) 3m HF-ANT_130829 VERTICAL RBW: 1000.000kHz VBW:3000.000kHz SWT:Auto Detector : Peak</p>	<p>Level (dBuV/m) vs Frequency (MHz) plot for Fundamental antenna. The plot shows a signal level of 15.209 dBm (PEAK) at 2462 MHz. The y-axis ranges from 17.5 to 140 dBuV/m, and the x-axis ranges from 1000 to 3000 MHz. A red box highlights the peak at 2462 MHz.</p> <p>Site : 03CH07-HY Condition : 15.209(PEAK) 3m HF-ANT_130829 VERTICAL RBW: 1000.000kHz VBW:3000.000kHz SWT:Auto Detector : Peak</p>
Avg.	<p>Level (dBuV/m) vs Frequency (MHz) plot for Vertical antenna. The plot shows a signal level of 15.209 dBm (AVG) at 2462 MHz. The y-axis ranges from 17.5 to 140 dBuV/m, and the x-axis ranges from 2460 to 2500 MHz. A red box highlights the peak at 2462 MHz.</p> <p>Site : 03CH07-HY Condition : 15.209(AVG) 3m HF-ANT_130829 VERTICAL RBW: 1000.000kHz VBW:1.000kHz SWT:Auto Detector : Peak</p>	<p>Level (dBuV/m) vs Frequency (MHz) plot for Fundamental antenna. The plot shows a signal level of 15.209 dBm (AVG) at 2462 MHz. The y-axis ranges from 17.5 to 140 dBuV/m, and the x-axis ranges from 1000 to 3000 MHz. A red box highlights the peak at 2462 MHz.</p> <p>Site : 03CH07-HY Condition : 15.209(AVG) 3m HF-ANT_130829 VERTICAL RBW: 1000.000kHz VBW:1.000kHz SWT:Auto Detector : Peak</p>



2.4GHz 2400~2483.5MHz
WIFI 802.11b (Harmonic @ 3m)

WIFI	2.4GHz 2400~2483.5MHz Harmonic @ 3m	
ANT	802.11b CH01 2412MHz	
1	Horizontal	Vertical
Peak Avg.	<p>Site : 03CH07.HY Condition : 15.209(PEAK) 3m SHF-EHF_131029 HORIZONTAL Detector : Peak</p>	<p>Site : 03CH07.HY Condition : 15.209(PEAK) 3m SHF-EHF_131029 VERTICAL Detector : Peak</p>



WIFI	2.4GHz 2400~2483.5MHz Harmonic @ 3m	
ANT	802.11b CH06 2437MHz	
1	Horizontal	Vertical
Peak Avg.	<p>Site : 03CH07HY Condition : 15.209(PEAK) 3m SHF-EHF_131029 HORIZONTAL Detector : Peak</p>	<p>Site : 03CH07HY Condition : 15.209(PEAK) 3m SHF-EHF_131029 VERTICAL Detector : Peak</p>



WIFI	2.4GHz 2400~2483.5MHz Harmonic @ 3m	
ANT	802.11b CH11 2462MHz	
1	Horizontal	Vertical
Peak Avg.	<p>Site : 03CH07.HY Condition : 15.209(PK) 3m SHF-EHF_131029 HORIZONTAL Detector : Peak</p>	<p>Site : 03CH07.HY Condition : 15.209(PK) 3m SHF-EHF_131029 VERTICAL Detector : Peak</p>



2.4GHz 2400~2483.5MHz
 WIFI 802.11g (Harmonic @ 3m)

WIFI	2.4GHz 2400~2483.5MHz Harmonic @ 3m	
ANT	802.11g CH01 2412MHz	
1	Horizontal	Vertical
Peak Avg.	<p>Site : 03CH07HY Condition : 15.209(PEAK) 3m SHF-EHF_131029 HORIZONTAL Detector : Peak</p>	<p>Site : 03CH07HY Condition : 15.209(PEAK) 3m SHF-EHF_131029 VERTICAL Detector : Peak</p>



WIFI	2.4GHz 2400~2483.5MHz Harmonic @ 3m	
ANT	802.11g CH06 2437MHz	
1	Horizontal	Vertical
Peak Avg.	<p>Site : 03CH07.HY Condition : 15.209(PEAK) 3m SHF-EHF_131029 HORIZONTAL Detector : Peak</p>	<p>Site : 03CH07.HY Condition : 15.209(PEAK) 3m SHF-EHF_131029 VERTICAL Detector : Peak</p>



WIFI	2.4GHz 2400~2483.5MHz Harmonic @ 3m	
ANT	802.11g CH11 2462MHz	
1	Horizontal	Vertical
Peak Avg.	<p>Site : 03CH0741Y Condition : 15.209(PEAK) 3m SHF-EHF_131029 HORIZONTAL Detector : Peak</p>	<p>Site : 03CH0741Y Condition : 15.209(PEAK) 3m SHF-EHF_131029 VERTICAL Detector : Peak</p>



2.4GHz 2400~2483.5MHz
WIFI 802.11n HT20 (Harmonic @ 3m)

Table with 3 columns: WIFI, ANT, and measurement results for Horizontal and Vertical orientations. Includes two graphs showing Level (dBuV/m) vs Frequency (MHz) with Peak and Avg values.



WIFI	2.4GHz 2400~2483.5MHz Harmonic @ 3m	
ANT	802.11n HT20 CH06 2437MHz	
1	Horizontal	Vertical
Peak Avg.	<p>Site : 03CH07.HY Condition : 15.209(PK) 3m SHF-EHF_131029 HORIZONTAL Detector : Peak</p>	<p>Site : 03CH07.HY Condition : 15.209(PK) 3m SHF-EHF_131029 VERTICAL Detector : Peak</p>



WIFI	2.4GHz 2400~2483.5MHz Harmonic @ 3m	
ANT	802.11n HT20 CH11 2462MHz	
1	Horizontal	Vertical
Peak Avg.	<p>Site : 03CH07.HY Condition : 15.209(PK) 3m SHF-EHF_131029 HORIZONTAL Detector : Peak</p>	<p>Site : 03CH07.HY Condition : 15.209(PK) 3m SHF-EHF_131029 VERTICAL Detector : Peak</p>



Emission below 1GHz
2.4GHz WIFI 802.11g (LF)

WIFI	2.4GHz 2400~2483.5MHz	
ANT	802.11g LF	
1	Horizontal	Vertical
QP / Peak	<p>Horizontal emission spectrum graph showing Level (dBuV/m) vs Frequency (MHz) with a peak at 15.209. Site: 03CH071HY, Condition: 15.209 3m LF-ANT:35419(6) HORIZONTAL, Detector: Peak.</p>	<p>Vertical emission spectrum graph showing Level (dBuV/m) vs Frequency (MHz) with a peak at 15.209. Site: 03CH071HY, Condition: 15.209 3m LF-ANT:35419(6) VERTICAL, Detector: Peak.</p>



Appendix D. Duty Cycle Plots

Band	Duty Cycle(%)	T(us)	1/T(kHz)	VBW Setting
802.11b	97.143	8150	0.12	300Hz
802.11g	86.076	1360	0.74	10Hz
2.4GHz 802.11n HT20	85.14	1260	0.79	1kHz

802.11b

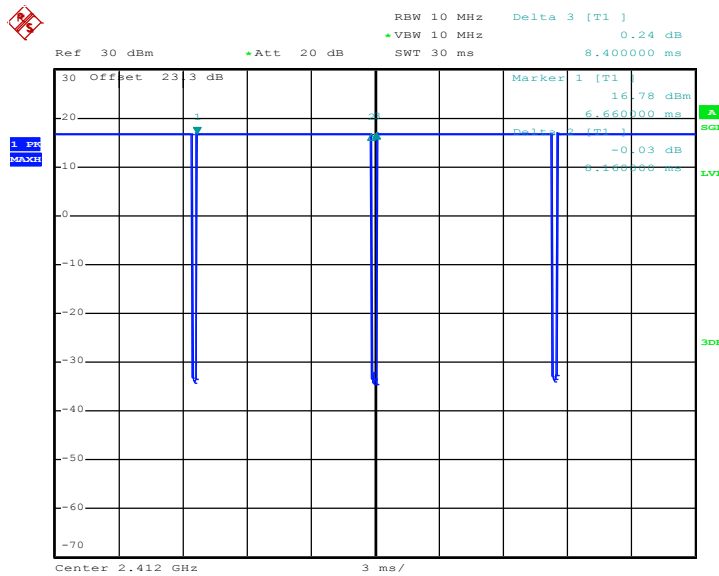

Date: 19.JUL.2016 17:19:20



802.11g

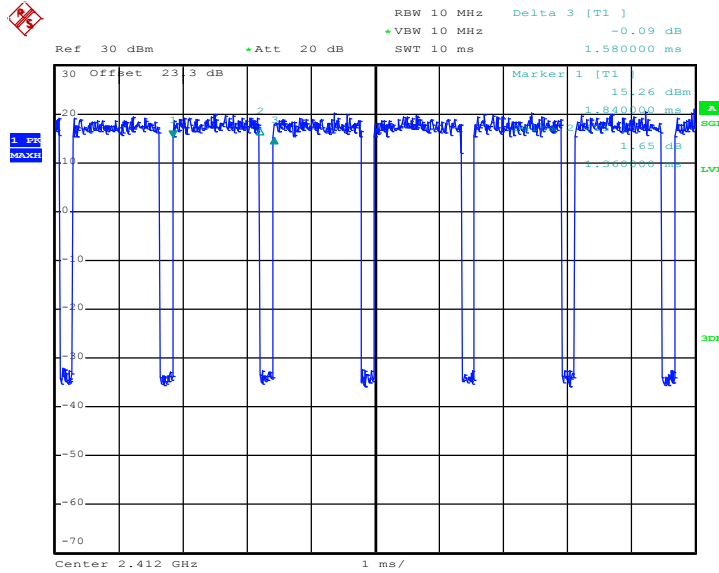

Date: 19.JUL.2016 17:24:53

802.11n HT20

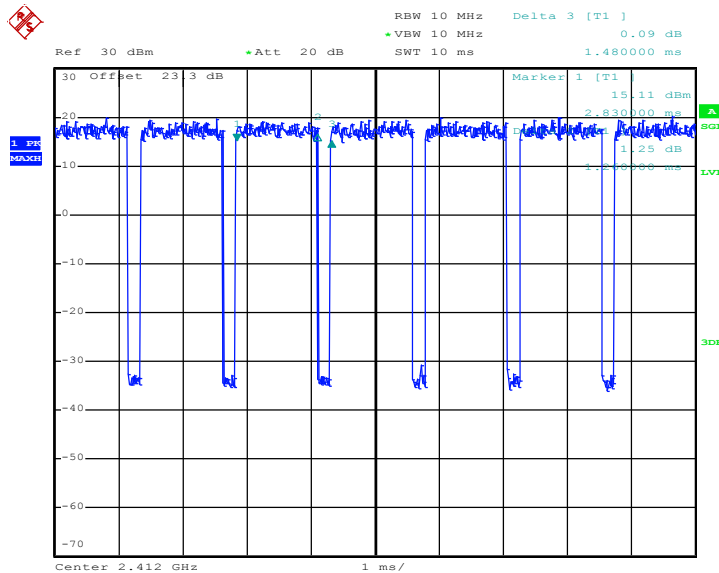

Date: 19.JUL.2016 17:26:00