

**TEST REPORT
FROM
RFI GLOBAL SERVICES LTD**

Test of: NTT Docomo, EB-4054

To: OET Bulletin 65 Supplement C: (2001-01)

Test Report Serial No:

RFI/SAR/RP85051JD03A V2.0

Version 2.0 Supersedes All Previous Version

**This Test Report Is Issued Under The Authority
Of Chris Guy Global Approvals:**



pp Brian Watson

(APPROVED SIGNATORY)

Checked By: Richelieu Quoi



(APPROVED SIGNATORY)

Issue Date:

02 Feuary 2012

Test Dates:

09 January to 18 January 2012

This report is issued in portable document format (PDF). It is only a valid copy of the report if it is being viewed in PDF format with the following security options not allowed: Changing the document, Selecting text and graphics, Adding or changing notes and form fields.

This report may not be reproduced other than in full, except with the prior written approval of RFI Global Services Ltd. The results in this report apply only to the sample(s) tested.

The Bluetooth® word mark and logos are owned by the *Bluetooth* SIG, Inc. and any use of such marks by RFI Global Services Ltd. is under license. Other trademarks and trade names are those of their respective owners.

This page has been left intentionally blank.

TABLE OF CONTENTS

1. Customer Information 4

2. Equipment Under Test (EUT) 5

3. Test Specification, Methods and Procedures 10

4. Deviations from the Test Specification..... 11

5. Operation and Configuration of the EUT during Testing 12

6. Summary of Test Results 14

7. Measurements, Examinations and Derived Results 16

8. Measurement Uncertainty 38

Appendix 1. Test Equipment Used 45

Appendix 2. Measurement Methods 48

Appendix 3. SAR Distribution Scans 50

Appendix 4. Photographs 127

Appendix 5. Validation of System 154

Appendix 6. Simulated Tissues 158

Appendix 7. DASY4 System Details 159

1. Customer Information

Company Name:	Panasonic Mobile Comms Dev of Europe Ltd
Address:	Panasonic House, Willoughby Road, Bracknell, Berkshire, RG12 8FP, United Kingdom

2. Equipment Under Test (EUT)

2.1. Identification of Equipment Under Test (EUT)

Description:	Mobile Handset
Brand Name:	NTT Docomo
Model Name or Number:	EB-4054
Serial Number:	None Stated (Customer Reference C21)
IMEI Number:	359569040021629
Hardware Version Number:	Rev C
Software Version Number:	ACPU:dcm-07-0215 CCPU:R1B_1_EC02_01_D00
Hardware Revision of GSM Module:	Not Applicable
Software Revision of GSM Module:	Not Applicable
FCC ID Number:	UCE211046A
Country of Manufacture:	Japan
Date of Receipt:	09 January 2012

Note(s):

This sample was used to perform 2G, 3G and WLAN SAR evaluations only. The sample supports simultaneous transmission with the WWAN and WLAN antenna > 5 cm apart. Wireless Personal Hotspot is also supported and was evaluated as per KDB 941225 D06 "Hot Spot SAR v01"

Description:	Mobile Handset
Brand Name:	NTT Docomo
Model Name or Number:	EB-4054
Serial Number:	None Stated (Customer Reference C22)
IMEI Number:	359569040021637
Hardware Version Number:	Rev C
Software Version Number:	ACPU:dcm-07-0215 CCPU:R1B_1_EC02_01_D00
Hardware Revision of GSM Module:	Not Applicable
Software Revision of GSM Module:	Not Applicable
FCC ID Number:	UCE211046A
Country of Manufacture:	Japan
Date of Receipt:	09 January 2012

Note(s):

This sample was used to perform 2G, 3G and WLAN conducted power measurements evaluation only. The sample supports simultaneous transmission with the WWAN and WLAN antenna > 5 cm apart. Wireless Personal Hotspot is also supported and was evaluated as per KDB 941225 D06 "Hot Spot SAR v01"

2.2. Description of EUT

The equipment under test was a Dual-mode UMTS/GSM mobile handset operating in the GSM850, PCS1900, UMTS FDD V and WiFi 2450 bands. The EUT has GPRS class 12, WiFi802.11b/g/n, Wireless Personal Hotspot Mode, *Bluetooth* and RFID capabilities.

2.3. Modifications Incorporated in the EUT

EUT (IMEI: 359569040021629) was used to perform 2G, 3G and WLAN SAR evaluations only.

EUT (IMEI: 359569040021637) was used for perform 2G, 3G and WLAN conducted power measurements only.

2.4. Accessories

The following accessories were supplied with the EUT during testing:

Description:	Personal Hands-Free (PHF)
Brand Name:	NTT Docomo
Model Name or Number:	None Stated
Serial Number:	None Stated
Cable Length and Type:	~1.15m
Country of Manufacture:	None Stated
Connected to Port	3.5mm Audio jack and custom type

Description:	Internal Battery
Brand Name:	None Stated
Model Name or Number:	None Stated
Serial Number:	None Stated
Cable Length and Type:	Not Applicable
Country of Manufacture:	None Stated
Connected to Port	None Stated

2.5. Support Equipment

The following support equipment was used to exercise the EUT during testing:

Description:	Wireless Communication Test Set
Brand Name:	Agilent
Model Name or Number:	8960 Series 10
Serial Number:	GB46311280
Cable Length and Type:	~4.0m Utiflex Cable
Connected to Port:	RF (Input / Output) Air Link

Description:	Wireless Communication Test Set
Brand Name:	Agilent
Model Name or Number:	8960 Series 10
Serial Number:	MY50264135
Cable Length and Type:	~4.0m Utiflex Cable
Connected to Port:	RF (Input / Output) Air Link

2.6. Additional Information Related to Testing			
Equipment Category	GSM/GPRS/EDGE850, PCS/GPRS/EDGE1900, UMTS FDD V / WiFi802.11b/g/n / <i>Bluetooth</i> / RFID		
Type of Unit	Portable Transceiver		
Intended Operating Environment:	Within GSM, UMTS, <i>Bluetooth</i> and Wi-Fi Coverage		
Transmitter Maximum Output Power Characteristics:	GSM850	Communication Test Set was configured to allow the EUT to transmit at a maximum power using Power Control Level (PCL) setting of 5.	
	PCS1900	Communication Test Set was configured to allow the EUT to transmit at a maximum power using Power Control Level (PCL) setting of 0.	
	UMTS FDD V	Communication Test Set configured to allow to EUT to transmit at a maximum power as per KDB 941225 D01.	
	Wi-Fi802.11b/g/n	Communication Test Set was configured to allow the EUT to transmit at a maximum power of up to 14.7 dBm.	
	<i>Bluetooth</i>	< 2 dBm	
Transmitter Frequency Range:	GSM850	(824 to 849) MHz	
	PCS1900	(1850 to 1910) MHz	
	UMTS FDD V	(826 to 847) MHz	
	WiFi802.11b/g/n	(2412 to 2462) MHz	
Transmitter Frequency Allocation of EUT When Under Test:	Channel Number	Channel Description	Frequency (MHz)
	128	Low	824.2
	189	Middle	836.4
	251	High	848.8
	512	Low	1850.2
	660	Middle	1879.8
	810	High	1909.8
	4132	Low	826.4
	4183	Middle	836.6
	4233	High	846.6
	1	Low	2412.0
	6	Middle	2437.0
	11	High	2462.0

Additional Information Related to Testing (Continued)

Modulation(s):	GMSK (GSM/ GPRS /EDGE): 217 Hz QPSK(UMTS / HSDPA/HSPA):0Hz DBPSK, CCK (Wi-Fi): 0 Hz
Modulation Scheme (Crest Factor):	GMSK (GSM): 8.3 GMSK (GPRS / EDGE): 2 DBPSK, CCK (Wi-Fi): 1 QPSK(UMTS FDD / HSDPA): 1
Antenna Type:	Internal Integral
Antenna Length:	Unknown
Number of Antenna Positions:	Main: 2 fixed (WWAN, WLAN / WPAN)
Power Supply Requirement:	3.8V
Battery Type(s):	Li-ion

3. Test Specification, Methods and Procedures

3.1. Test Specification

Reference:	OET Bulletin 65 Supplement C: (2001-01)
Title:	Evaluating Compliance with FCC Guidelines for Human Exposure to Radio Frequency Electromagnetic Fields.
Purpose of Test:	To determine whether the equipment met the basic restrictions as defined in OET Bulletin 65 Supplement C: (2001-01) using the SAR averaging method as described in the test specification above.

3.2. Methods and Procedures Reference Documentation

The methods and procedures used were as detailed in:

Federal Communications Commission, "Evaluating compliance with FCC Guidelines for human exposure to radio frequency electromagnetic fields", OET Bulletin 65 Supplement C, FCC, Washington, D.C, 20554, 2001.

Thomas Schmid, Oliver Egger and Neils Kuster, "Automated E-field scanning system for dosimetric assessments", IEEE Transaction on microwave theory and techniques, Vol. 44, pp. 105-113, January 1996.

Neils Kuster, Ralph Kastle and Thomas Schmid, "Dosimetric evaluation of mobile communications equipment with know precision", IEICE Transactions of communications, Vol. E80-B, No.5, pp. 645-652, May 1997.

KDB 248227 D01 "SAR measurements for 802.11a/b/g v01r02"

KDB 447498 D01 "Mobile Portable RF Exposure v04"

KDB 648474 D01 SAR Handsets Multi Xmitter and Ant v01r05"

KDB 941225 D01 "SAR test for 3G v02"

KDB 941225 D03 " SAR Test Reduction GSM/GPRS/EDGE v01"

KDB 941225 D06 "Hot Spot SAR v01"

The version of DASY system used by RFI for SAR measurements is v4.7.

The SAR probe for the DASY v4.4 and higher has a validity of +/- 100 MHz from the spot frequency at which the system is calibrated.

The system validation performed at 900 MHz is valid for 800 MHz to 1000 MHz which covers the 850 MHz band. The probe calibration for SN: 1528 was performed at the spot frequencies of 750 MHz and 900 MHz. The SAR software selects the conversion factor based on the following attributes; 1. The operating frequency 2. The measured permittivity imported to the software and 3. The measured conductivity imported to the software.

The 900 MHz validation is applicable for the 850 band as this is within 50 MHz of the of the 850 MHz spot frequency.

3.3. Definition of Measurement Equipment

The measurement equipment used complied with the requirements of the standards referenced in the methods & procedures section above. Appendix 1 contains a list of the test equipment used.

4. Deviations from the Test Specification

Test was performed as per KDB 648474 D01 "SAR Handsets Multi Xmitter and Ant v01r05", KDB 941225 D01/D03 " SAR Test Reduction GSM/GPRS/EDGE v01", KDB 941225 D01 "SAR test for 3G v02", KDB 248227 D01 "SAR measurements for 802.11a/b/g v01r02" and KDB 941225 D06 "Hot Spot SAR v01" according to the handset procedures in IEEE Std 1528-2003 and OET Bulletin 65 Supplement C 01-01. The assessment for Personal Wireless Hotspot was also evaluated as per the FCC KDB 941225 D06 "Hot Spot SAR v01".

For technologies bands supporting personal hotspot mode, SAR was evaluated on all the sides and surfaces within 25mm of the transmitting antenna (WWAN or WLAN) as per FCC KDB 941225 D06 "Hot Spot SAR v01".

Simultaneous transmission was not evaluated as the sum of the individual SAR for WWAN and WLAN was < 1.6 W/kg and the antenna-to-antenna distance was greater than 5 cm.

The samples used for SAR assessment were as per section 2 of this report.

GPRS class 12 uplink setup of 1-uplink, 2-uplink, 3-uplink and 4-uplink were all evaluated to find the setting with the highest power reference measurements. 4-uplink was found to give the highest power reference measurement on the DASY4 system. All settings were performed with the device in a fixed position to ensure there were no positioning errors. The following values were measured relative to the uplink settings:

GPRS Mode	GPRS850 Band Power (v/m)	GPRS1900 Power (v/m)
1 uplink	23.05	10.59
2 uplink	25.10	11.55
3 uplink	24.96	11.60
4 uplink	25.42	11.68

5. Operation and Configuration of the EUT during Testing

5.1. Operating Modes

The EUT was tested in the following operating mode(s) unless otherwise stated:

- GSM850 – Voice allocated mode with Communication Test Set configured to allow the EUT to transmit at a maximum power using Power Control Level (PCL) setting of 5.
- GPRS/EDGE850 – Data allocated mode with Communication Test Set configured to allow the EUT to transmit at a maximum power using Power Control Level (PCL) setting of 5. Tested using 4 Uplink time slots with CS1 and MCS4 for GPRS and EDGE respectively.
- PCS1900 – Voice allocated mode with Communication Test Set configured to allow the EUT to transmit at a maximum power using Power Control Level (PCL) setting of 0.
- GPRS/EDGE1900 – Data allocated mode with Communication Test Set configured to allow the EUT to transmit at a maximum power using Power Control Level (PCL) setting of 0. Tested using 4 Uplink time slots with CS1 and MCS4 for GPRS and EDGE respectively.

GSM850 / EGSM900 – Power Table Settings used for Test Set	
Power Control Level PCL	Nominal Power (dBm)
0 ... 2	39
3	37
4	35
5	33
6	31
7	29
8	27
9	25
10	23
11	21
12	19
13	17
14	15
15	13
16	11
17	9
18	7
19 ... 31	5

DCS1800 / PCS1900 – Power Table Settings used for Test Set	
Power Control Level PCL	Nominal Power (dBm)
22 ... 29	Reserved
30	33
31	32
0	30
1	28
2	26
3	24
4	22
5	20
6	18
7	16
8	14
9	12
10	10
11	8
12	6
13	4
14	2
15	0
16 ... 21	Reserved

- UMTS FDD V Circuit Switch (CS) – RMC 12.2kbps with Communication Test Set configured with TPC bits configured to all "1's" to allow the EUT to transmit at a maximum as per KDB 941225 D01.
- UMTS FDD V - Packet Switch (PS) - RMC 12.2kbps + HSDPA with test loop mode 1 and TPC bits configured to all "1's", Sub-test 1 with Communication Test Set configured to allow to EUT to transmit at a maximum power as per KDB 941225 D01.
- UMTS FDD V – Packet Switch (PS) - RMC 12.2kbps + HSUPA with test loop mode 1 and TPC bits configured to all "1's", Sub-test 5, AG Index set to 21 and E-TFCI set to 81 with Communication Test Set configured to allow to EUT to transmit at a maximum power as per KDB 941225 D01.
- WiFi802.11b/g/n Data allocated mode using 'FaCTA V2.0.0.2' software to excise mode 'b', 'g' and 'n', with maximum power of up to 14.7dBm for 'b' mode and 13.3dBm for 'g' and 13.1dBm for 'n' modes.

5.2. Configuration and Peripherals

The EUT was tested in the following configuration(s) unless otherwise stated:

- Standalone fully charged battery powered.
- Head and Body-worn configurations were evaluated.
- The applied FCC body-worn Personal Hotspot orientations where the corresponding edge(s) closest to the user with the most conservative exposure condition were all evaluated at 10 mm from the body. For configuration that did not overlap with Personal hotspot, SAR evaluation was performed at 15mm separation.
- GPRS class 12 uplink setup of 1-uplink, 2-uplink, 3-uplink and 4-uplink were all evaluated to find the setting with the highest power reference measurements. 4-uplink for GPRS850/EDGE and 4-uplink for GPRS/EDGE1900 was found to give the highest power reference measurement on the DASY4 system. All settings were performed with the device in a fixed position to ensure there were no positioning errors.

Head Configuration

- a) The EUT was placed in a normal operating position with the centre of the ear-piece aligned with the ear canal on the phantom.
- b) With the ear-piece touching the phantom the centre line of the EUT was aligned with an imaginary plane (X and Y axis) consisting of three lines connecting both ears and the mouth.
- c) For the cheek position the EUT was gradually moved towards the cheek until any point of the mouth-piece or keypad touched the cheek.
- d) For the tilted position the EUT was positioned as for the cheek position, and then the horizontal angle was increased by fifteen degrees (the phone keypad was moved away from the cheek by fifteen degrees).
- e) SAR measurements were evaluated at maximum power and the unit was operated for an appropriate period prior to the evaluation in order to minimise the drift.
- f) The device was keyed to operate continuously in the transmit mode for the duration of the test.
- g) The location of the maximum spatial SAR distribution (hot spot) was determined relative to the EUT and its antenna.
- h) The EUT was transmitting at full power throughout the duration of the test powered by a fully charged battery.

Body Configuration

- a) The EUT was placed in a normal operating position where the centre of EUT was aligned with the centre reference point on the flat section of the 'SAM' phantom.
- b) With the EUT touching the phantom at an imaginary centre line. The EUT was aligned with a marked plane (X and Y axis) consisting of two lines.
- c) For the touch-safe position the EUT was gradually moved towards the flat section of the 'SAM' phantom until any point of the EUT touched the phantom.
- d) For position(s) greater than 0mm separation the EUT was positioned as per the touch-safe position, and then the vertical height was decreased/adjusted as required.
- e) SAR measurements were evaluated at maximum power and the unit was operated for an appropriate period prior to the evaluation in order to minimise the drift.
- f) The device was keyed to operate continuously in the transmit mode for the duration of the test.
- g) The location of the maximum spatial SAR distribution (hot spot) was determined relative to the EUT and its antenna.
- h) The EUT was transmitting at full power throughout the duration of the test powered by a fully charged battery.

6. Summary of Test Results

Test Name	Specification Reference	Result
Specific Absorption Rate-GSM 850 Head Configuration 1g	OET Bulletin 65 Supplement C: (2001-01)	Complied
Specific Absorption Rate-GPRS 850 Head Configuration 1g	OET Bulletin 65 Supplement C: (2001-01)	Complied
Specific Absorption Rate-EDGE 850 Head Configuration 1g	OET Bulletin 65 Supplement C: (2001-01)	Complied
Specific Absorption Rate-GPRS 850 Body Configuration 1g	OET Bulletin 65 Supplement C: (2001-01)	Complied
Specific Absorption Rate-EDGE 850 Body Configuration 1g	OET Bulletin 65 Supplement C: (2001-01)	Complied
Specific Absorption Rate-GSM 850 Body Configuration 1g	OET Bulletin 65 Supplement C: (2001-01)	Complied
Specific Absorption Rate-PCS 1900 Head Configuration 1g	OET Bulletin 65 Supplement C: (2001-01)	Complied
Specific Absorption Rate-GPRS 1900 Head Configuration 1g	OET Bulletin 65 Supplement C: (2001-01)	Complied
Specific Absorption Rate-EDGE 1900 Head Configuration 1g	OET Bulletin 65 Supplement C: (2001-01)	Complied
Specific Absorption Rate-GPRS 1900 Body Configuration 1g	OET Bulletin 65 Supplement C: (2001-01)	Complied
Specific Absorption Rate-EDGE 1900 Body Configuration 1g	OET Bulletin 65 Supplement C: (2001-01)	Complied
Specific Absorption Rate-PCS 1900 Body Configuration 1g	OET Bulletin 65 Supplement C: (2001-01)	Complied
Specific Absorption Rate-UMTS-FDD V Head Configuration 1g	OET Bulletin 65 Supplement C: (2001-01)	Complied
Specific Absorption Rate-UMTS-FDD V Body Configuration 1g	OET Bulletin 65 Supplement C: (2001-01)	Complied
Specific Absorption Rate-UMTS-FDD V + HSPA Body Configuration 1g	OET Bulletin 65 Supplement C: (2001-01)	Complied
Specific Absorption Rate- Wi-Fi 802.11b/g/n Head Configuration 1g	OET Bulletin 65 Supplement C: (2001-01)	Complied
Specific Absorption Rate- Wi-Fi 802.11b/g/n Body Configuration 1g	OET Bulletin 65 Supplement C: (2001-01)	Complied

Summary of Test Results (continued)**SAR Individual Transmitter Evaluation**

device, mode	Frequency, (MHz)	P _x (mW)	P _{REF} (mW)	single SAR, W/kg	Remarks
WWAN, GSM	850	1820	60/f	1.03	Routine Evaluation
WWAN, GSM	1900	912	60/f	0.587	Routine Evaluation
WWAN, UMTS	850	214	60/f	0.916	Routine Evaluation
WLAN, WiFi802.11b/g	2450	30	12	0.155	Routine Evaluation
BT, <i>Bluetooth</i>	2400	~ 2	12	:=0	{P _{BT} ≤ 2P _{REF} } {d _{WWAN, BT} > 5cm}

SAR Simultaneous Transmitter Evaluation

(x,y)	D(x,y) cm	L(x,y) cm	SPLSR _{xy}	Sim-Tx SAR	Remarks
(WWAN _{GSM} , BT)	>5	N/A	N/A	N/A	{no stand-alone SAR for BT}
(WWAN _{GSM} , Wi-Fi)	>5	N/A	N/A	N/A	{D(x,y) > 5 } & {Σ _{WWAN, WLAN} < 1.6 W/kg}

Note(s):

1. Simultaneous transmission evaluation was not required as the output power for *Bluetooth* was < (60/f) and the Sum of all antenna < 1.6w/kg.
2. *Bluetooth* transmitter thresholds output power "P_{Ref} = 12 mW as listed in KDB 648474.
3. P_x: power level measured by RFI.
4. Single SAR value was measured by RFI.
5. The "Antenna-to-Antenna distance and Antenna-to-User distance were provided by the customer.

6.1. Location of Tests

All the measurements described in this report were performed at the premises of RFI Global Services Ltd, Pavilion A, Ashwood Park, Ashwood Way, Basingstoke, Hampshire, RG23 8BG United Kingdom

7. Measurements, Examinations and Derived Results

7.1. General Comments

This section contains test results only.

Measurement uncertainties are evaluated in accordance with current best practice. Our reported expanded uncertainties are based on standard uncertainties, which are multiplied by an appropriate coverage factor to provide a statistical confidence level of approximately 95%. Please refer to section 8 for details of measurement uncertainties.

7.2. Test Results

7.2.1. Specific Absorption Rate - GSM 850 Head Configuration 1g

Test Summary:

Tissue Volume:	1g
Maximum Level (W/kg):	0.474

Environmental Conditions:

Temperature Variation in Lab (°C):	22.0 to 22.0
Temperature Variation in Liquid (°C):	22.5 to 22.5

Results:

EUT Position	Phantom Configuration	Channel Number	Level (W/kg)	Limit (W/kg)	Margin (W/kg)	Note(s)	Result
Touch	Left	189	0.467	1.600	1.133	1	Complied
Tilt	Left	189	0.268	1.600	1.332	1	Complied
Touch	Right	189	0.474	1.600	1.126	1	Complied
Tilt	Right	189	0.329	1.600	1.271	1	Complied

Note(s):

- SAR test was performed in the middle channel only as the measured levels were < 50% of the SAR limit as stated in the FCC Public Notice DA 02-1438 by the SCC-34/SC-2.

7.2.2. Specific Absorption Rate - GPRS 850 Head Configuration 1g**Test Summary:**

Tissue Volume:	1g
Maximum Level (W/kg):	0.535

Environmental Conditions:

Temperature Variation in Lab (°C):	22.0 to 22.0
Temperature Variation in Liquid (°C):	22.5 to 22.5

Results:

EUT Position	Phantom Configuration	Channel Number	Level (W/kg)	Limit (W/kg)	Margin (W/kg)	Note(s)	Result
Touch	Right	189	0.535	1.600	1.065	1, 2, 3	Complied

Note(s):

1. SAR test was performed in the middle channel only as the measured levels were < 50% of the SAR limit as stated in the FCC Public Notice DA 02-1438 by the SCC-34/SC-2.
2. SAR measurements were performed using 4 uplink timeslots.
3. Worst case configuration from GSM is used on GPRS head.

7.2.3. Specific Absorption Rate - EDGE 850 Head Configuration 1g Test Summary:

Tissue Volume:	1g
Maximum Level (W/kg):	0.528

Environmental Conditions:

Temperature Variation in Lab (°C):	22.0 to 22.0
Temperature Variation in Liquid (°C):	22.5 to 22.5

Results:

EUT Position	Phantom Configuration	Channel Number	Level (W/kg)	Limit (W/kg)	Margin (W/kg)	Note(s)	Result
Touch	Right	189	0.528	1.600	1.072	1, 2, 3	Complied

Note(s):

1. SAR test was performed in the middle channel only as the measured levels were < 50% of the SAR limit as stated in the FCC Public Notice DA 02-1438 by the SCC-34/SC-2.
2. SAR measurements were performed using 4 uplink timeslots.
3. Worst case configuration from GSM is used on EDGE head.

7.2.4. Specific Absorption Rate - GPRS 850 Body Configuration 1g**Test Summary:**

Tissue Volume:	1g
-----------------------	----

Maximum Level (W/kg):	0.969
------------------------------	-------

Environmental Conditions:

Temperature Variation in Lab (°C):	22.0 to 22.0
---	--------------

Temperature Variation in Liquid (°C):	22.2 to 22.2
--	--------------

Results:

EUT Position	Phantom Configuration	Channel Number	Level (W/kg)	Limit (W/kg)	Margin (W/kg)	Note(s)	Result
Front of EUT Facing Phantom	Flat (SAM)	189	0.867	1.600	0.733	1, 2	Complied
Front of EUT Facing Phantom	Flat (SAM)	128	0.746	1.600	0.854	1, 2	Complied
Front of EUT Facing Phantom	Flat (SAM)	251	0.969	1.600	0.631	1, 2	Complied
Rear of EUT Facing Phantom	Flat (SAM)	189	0.856	1.600	0.744	1, 2	Complied
Rear of EUT Facing Phantom	Flat (SAM)	128	0.757	1.600	0.843	1, 2	Complied
Rear of EUT Facing Phantom	Flat (SAM)	251	0.948	1.600	0.652	1, 2	Complied
Left Hand Side of EUT Facing Phantom	Flat (SAM)	189	0.713	1.600	0.887	1, 2	Complied
Right Hand Side of EUT Facing Phantom	Flat (SAM)	189	0.529	1.600	1.071	1, 2	Complied
Bottom of EUT Facing Phantom	Flat (SAM)	189	0.125	1.600	1.475	1, 2	Complied

Note(s):

1. SAR measurements were performed with the closest edge of the EUT at a separation distance of 10mm from the 'SAM' phantom flat section as person hotspot mode is supported.
2. SAR measurements were performed using 4 uplink timeslots

7.2.5. Specific Absorption Rate - EDGE 850 Body Configuration 1g Test Summary:

Tissue Volume: 1g

Maximum Level (W/kg): 1.030

Environmental Conditions:

Temperature Variation in Lab (°C): 22.0 to 22.0

Temperature Variation in Liquid (°C): 22.2 to 22.2

Results:

EUT Position	Phantom Configuration	Channel Number	Level (W/kg)	Limit (W/kg)	Margin (W/kg)	Note(s)	Result
Front of EUT Facing Phantom	Flat (SAM)	189	0.860	1.600	0.740	1, 2, 3	Complied
Front of EUT Facing Phantom	Flat (SAM)	128	0.737	1.600	0.863	1, 2, 3	Complied
Front of EUT Facing Phantom	Flat (SAM)	251	0.977	1.600	0.623	1, 2, 3	Complied
Front of EUT Facing Phantom With PHF	Flat (SAM)	189	0.914	1.600	0.686	1, 2, 3	Complied
Front of EUT Facing Phantom With PHF	Flat (SAM)	128	0.773	1.600	0.827	1, 2, 3	Complied
Front of EUT Facing Phantom With PHF	Flat (SAM)	251	1.030	1.600	0.570	1, 2, 3	Complied

Note(s):

1. SAR measurements were performed with the closest edge of the EUT at a separation distance of 10mm from the 'SAM' phantom flat section as person hotspot mode is supported.
2. SAR measurements were performed using 4 uplink timeslots
3. Worst case configuration and channel of GPRS were applied to EDGE body test.

7.2.6. Specific Absorption Rate - GSM 850 Body Configuration 1g**Test Summary:**

Tissue Volume:	1g
-----------------------	----

Maximum Level (W/kg):	0.763
------------------------------	-------

Environmental Conditions:

Temperature Variation in Lab (°C):	22.0 to 22.0
---	--------------

Temperature Variation in Liquid (°C):	22.2 to 22.2
--	--------------

Results:

EUT Position	Phantom Configuration	Channel Number	Level (W/kg)	Limit (W/kg)	Margin (W/kg)	Note(s)	Result
Front of EUT Facing Phantom	Flat (SAM)	189	0.763	1.600	0.837	1, 2, 3	Complied

Note(s):

1. SAR measurements were performed with the closest edge of the EUT at a separation distance of 10mm from the 'SAM' phantom flat section as person hotspot mode is supported.
2. SAR test was performed in the middle channel only as the measured levels were < 50% of the SAR limit as stated in the FCC Public Notice DA 02-1438 by the SCC-34/SC-2.
3. Worst case configuration and channel of GPRS were applied to GSM body test.

7.2.7. Specific Absorption Rate - PCS 1900 Head Configuration 1g Test Summary:

Tissue Volume:	1g
Maximum Level (W/kg):	0.444

Environmental Conditions:

Temperature Variation in Lab (°C):	24.0 to 24.0
Temperature Variation in Liquid (°C):	22.5 to 22.5

Results:

EUT Position	Phantom Configuration	Channel Number	Level (W/kg)	Limit (W/kg)	Margin (W/kg)	Note(s)	Result
Touch	Left	660	0.373	1.600	1.227	1	Complied
Tilt	Left	660	0.152	1.600	1.448	1	Complied
Touch	Right	660	0.444	1.600	1.156	1	Complied
Tilt	Right	660	0.175	1.600	1.425	1	Complied

Note(s):

- SAR test was performed in the middle channel only as the measured levels were < 50% of the SAR limit as stated in the FCC Public Notice DA 02-1438 by the SCC-34/SC-2.

7.2.8. Specific Absorption Rate - GPRS 1900 Head Configuration 1g**Test Summary:**

Tissue Volume:	1g
Maximum Level (W/kg):	0.552

Environmental Conditions:

Temperature Variation in Lab (°C):	24.0 to 24.0
Temperature Variation in Liquid (°C):	22.5 to 22.5

Results:

EUT Position	Phantom Configuration	Channel Number	Level (W/kg)	Limit (W/kg)	Margin (W/kg)	Note(s)	Result
Touch	Right	660	0.552	1.600	1.048	1, 2, 3	Complied

Note(s):

1. SAR test was performed in the middle channel only as the measured levels were < 50% of the SAR limit as stated in the FCC Public Notice DA 02-1438 by the SCC-34/SC-2.
2. SAR measurements were performed using 4 uplink timeslots.
3. Worst case configuration from PCS is used on GPRS head.

7.2.9. Specific Absorption Rate - EDGE 1900 Head Configuration 1g Test Summary:

Tissue Volume:	1g
Maximum Level (W/kg):	0.530

Environmental Conditions:

Temperature Variation in Lab (°C):	24.0 to 24.0
Temperature Variation in Liquid (°C):	22.5 to 22.5

Results:

EUT Position	Phantom Configuration	Channel Number	Level (W/kg)	Limit (W/kg)	Margin (W/kg)	Note(s)	Result
Touch	Right	660	0.530	1.600	1.070	1, 2, 3	Complied

Note(s):

1. SAR test was performed in the middle channel only as the measured levels were < 50% of the SAR limit as stated in the FCC Public Notice DA 02-1438 by the SCC-34/SC-2.
2. SAR measurements were performed using 4 uplink timeslots.
3. Worst case configuration from PCS is used on EDGE head.

7.2.10. Specific Absorption Rate - GPRS 1900 Body Configuration 1g**Test Summary:**

Tissue Volume:	1g
-----------------------	----

Maximum Level (W/kg):	0.587
------------------------------	-------

Environmental Conditions:

Temperature Variation in Lab (°C):	24.0 to 24.0
---	--------------

Temperature Variation in Liquid (°C):	23.7 to 23.7
--	--------------

Results:

EUT Position	Phantom Configuration	Channel Number	Level (W/kg)	Limit (W/kg)	Margin (W/kg)	Note(s)	Result
Front of EUT Facing Phantom	Flat (SAM)	660	0.572	1.600	1.028	1, 2, 3	Complied
Rear of EUT Facing Phantom	Flat (SAM)	660	0.587	1.600	1.013	1, 2, 3	Complied
Left Hand Side of EUT Facing Phantom	Flat (SAM)	660	0.087	1.600	1.513	1, 2, 3	Complied
Right Hand Side of EUT Facing Phantom	Flat (SAM)	660	0.210	1.600	1.390	1, 2, 3	Complied
Bottom of EUT Facing Phantom	Flat (SAM)	660	0.339	1.600	1.261	1, 2, 3	Complied
Rear of EUT Facing Phantom With PHF	Flat (SAM)	660	0.556	1.600	1.044	1, 2, 3	Complied

Note(s):

1. SAR measurements were performed with the closest edge of the EUT at a separation distance of 10mm from the 'SAM' phantom flat section as person hotspot mode is supported.
2. SAR measurements were performed using 4 uplink timeslots
3. SAR test was performed in the middle channel only as the measured levels were < 50% of the SAR limit as stated in the FCC Public Notice DA 02-1438 by the SCC-34/SC-2.

7.2.11. Specific Absorption Rate - EDGE 1900 Body Configuration 1g Test Summary:

Tissue Volume:	1g
----------------	----

Maximum Level (W/kg):	0.573
-----------------------	-------

Environmental Conditions:

Temperature Variation in Lab (°C):	24.0 to 24.0
------------------------------------	--------------

Temperature Variation in Liquid (°C):	23.7 to 23.7
---------------------------------------	--------------

Results:

EUT Position	Phantom Configuration	Channel Number	Level (W/kg)	Limit (W/kg)	Margin (W/kg)	Note(s)	Result
Rear of EUT Facing Phantom	Flat (SAM)	660	0.573	1.600	1.027	1, 2,3, 4	Complied

Note(s):

1. SAR measurements were performed with the closest edge of the EUT at a separation distance of 10mm from the 'SAM' phantom flat section as person hotspot mode is supported.
2. SAR measurements were performed using 4 uplink timeslots
3. SAR test was performed in the middle channel only as the measured levels were < 50% of the SAR limit as stated in the FCC Public Notice DA 02-1438 by the SCC-34/SC-2.
4. Worst case configuration and channel of GPRS were applied to EDGE body test.

7.2.12. Specific Absorption Rate - PCS 1900 Body Configuration 1g**Test Summary:**

Tissue Volume:	1g
-----------------------	----

Maximum Level (W/kg):	0.544
------------------------------	-------

Environmental Conditions:

Temperature Variation in Lab (°C):	24.0 to 24.0
---	--------------

Temperature Variation in Liquid (°C):	23.7 to 23.7
--	--------------

Results:

EUT Position	Phantom Configuration	Channel Number	Level (W/kg)	Limit (W/kg)	Margin (W/kg)	Note(s)	Result
Rear of EUT Facing Phantom	Flat (SAM)	660	0.544	1.600	1.056	1, 2, 3	Complied

Note(s):

1. SAR measurements were performed with the closest edge of the EUT at a separation distance of 10mm from the 'SAM' phantom flat section as person hotspot mode is supported.
2. SAR test was performed in the middle channel only as the measured levels were < 50% of the SAR limit as stated in the FCC Public Notice DA 02-1438 by the SCC-34/SC-2.
3. Worst case configuration and channel of GPRS were applied to PCS body test.

7.2.13. Specific Absorption Rate - UMTS-FDD V Head Configuration 1g Test Summary:

Tissue Volume:	1g
Maximum Level (W/kg):	0.512

Environmental Conditions:

Temperature Variation in Lab (°C):	23.0 to 23.0
Temperature Variation in Liquid (°C):	22.4 to 22.4

Results:

EUT Position	Phantom Configuration	Channel Number	Level (W/kg)	Limit (W/kg)	Margin (W/kg)	Note(s)	Result
Touch	Left	4183	0.492	1.600	1.108	1, 2	Complied
Tilt	Left	4183	0.281	1.600	1.319	1, 2	Complied
Touch	Right	4183	0.512	1.600	1.088	1, 2	Complied
Tilt	Right	4183	0.306	1.600	1.294	1, 2	Complied

Note(s):

1. SAR test was performed in the middle channel only as the measured levels were < 50% of the SAR limit as stated in the FCC Public Notice DA 02-1438 by the SCC-34/SC-2.
2. Circuit Switch (CS) - RMC 12.2kbps with Test loop mode 1 and TPC bits configured to All "1's"

7.2.14. Specific Absorption Rate - UMTS-FDD V Body Configuration 1g**Test Summary:**

Tissue Volume:	1g
-----------------------	----

Maximum Level (W/kg):	0.916
------------------------------	-------

Environmental Conditions:

Temperature Variation in Lab (°C):	23.0 to 23.0
---	--------------

Temperature Variation in Liquid (°C):	22.1 to 22.1
--	--------------

Results:

EUT Position	Phantom Configuration	Channel Number	Level (W/kg)	Limit (W/kg)	Margin (W/kg)	Note(s)	Result
Front of EUT Facing Phantom	Flat (SAM)	4183	0.702	1.600	0.898	1, 2	Complied
Rear of EUT Facing Phantom	Flat (SAM)	4183	0.731	1.600	0.869	1, 2	Complied
Left Hand Side of EUT Facing Phantom	Flat (SAM)	4183	0.313	1.600	1.287	1, 2	Complied
Right Hand Side of EUT Facing Phantom	Flat (SAM)	4183	0.298	1.600	1.302	1, 2	Complied
Bottom of EUT Facing Phantom	Flat (SAM)	4183	0.111	1.600	1.489	1, 2	Complied
Rear of EUT Facing Phantom With PHF	Flat (SAM)	4183	0.916	1.600	0.684	1, 2	Complied
Rear of EUT Facing Phantom With PHF	Flat (SAM)	4132	0.893	1.600	0.707	1, 2	Complied
Rear of EUT Facing Phantom With PHF	Flat (SAM)	4233	0.909	1.600	0.691	1, 2	Complied

Note(s):

- SAR measurements were performed with the closest edge of the EUT at a separation distance of 10mm from the 'SAM' phantom flat section as person hotspot mode is supported.
- Circuit Switch (CS) - RMC 12.2kbps with Test loop mode 1 and TPC bits configured to All "1's"

7.2.15. Specific Absorption Rate - UMTS-FDD V + HSPA Body Configuration 1g Test Summary:

Tissue Volume:	1g
Maximum Level (W/kg):	0.659

Environmental Conditions:

Temperature Variation in Lab (°C):	23.0 to 23.0
Temperature Variation in Liquid (°C):	22.1 to 22.1

Results:

EUT Position	Phantom Configuration	Channel Number	Level (W/kg)	Limit (W/kg)	Margin (W/kg)	Note(s)	Result
Rear of EUT Facing Phantom	Flat (SAM)	4183	0.659	1.600	0.941	1, 2, 4	Complied
Rear of EUT Facing Phantom	Flat (SAM)	4183	0.494	1.600	1.106	1, 3, 4	Complied

Note(s):

1. SAR measurements were performed with the closest edge of the EUT at a separation distance of 10mm from the 'SAM' phantom flat section as person hotspot mode is supported.
2. Packet Switch (PS) - RMC 12.2kbps with Test loop mode 1 and TPC bits configured to All "1's" with HSDPA enabled. Using Sub-test 1 with $\beta_c=2$ / $\beta_d=15$, ACK/NACK/CQI=8, as per KDB 941225 D01.
3. Packet Switch (PS) - FRC configured to HS-DPCCH Sub-test 5 and H-Set 1 and QPSK settings with HSUPA enabled. Using Sub-test 5 with $\beta_c=15$ / $\beta_d=15$, ACK/NACK/CQI=8, AG = 21, as per KDB 941225 D01.
4. The 'Worst case' configuration from RMC is used on HSPA (HSDPA/HSUPA) body configuration.

7.2.16. Specific Absorption Rate - Wi-Fi 802.11b/g/n Head Configuration 1g**Test Summary:**

Tissue Volume:	1g
-----------------------	----

Maximum Level (W/kg):	0.103
------------------------------	-------

Environmental Conditions:

Temperature Variation in Lab (°C):	23.0 to 23.0
---	--------------

Temperature Variation in Liquid (°C):	22.8 to 22.8
--	--------------

Results:

EUT Position	Phantom Configuration	Channel Number	Level (W/kg)	Limit (W/kg)	Margin (W/kg)	Note(s)	Result
Touch	Left	6	0.057	1.600	1.543	1, 2	Complied
Tilt	Left	6	0.067	1.600	1.533	1, 2	Complied
Touch	Right	6	0.086	1.600	1.514	1, 2	Complied
Tilt	Right	6	0.103	1.600	1.497	1, 2	Complied
Tilt	Right	6	0.053	1.600	1.547	1, 3	Complied
Tilt	Right	6	0.064	1.600	1.536	1, 4	Complied

Note(s):

1. SAR test was performed in the middle channel only as the measured levels were < 50% of the SAR limit as stated in the FCC Public Notice DA 02-1438 by the SCC-34/SC-2.
2. 802.11b 1Mbps
3. 802.11g 6Mbps
4. 802.11n 6.5Mbps

7.2.17. Specific Absorption Rate - Wi-Fi 802.11b/g/n Body Configuration 1g Test Summary:

Tissue Volume:	1g
Maximum Level (W/kg):	0.155

Environmental Conditions:

Temperature Variation in Lab (°C):	23.0 to 23.0
Temperature Variation in Liquid (°C):	22.3 to 22.3

Results:

EUT Position	Phantom Configuration	Channel Number	Level (W/kg)	Limit (W/kg)	Margin (W/kg)	Note(s)	Result
Front of EUT Facing Phantom	Flat (SAM)	6	0.016	1.600	1.584	1, 2, 3	Complied
Rear of EUT Facing Phantom	Flat (SAM)	6	0.127	1.600	1.473	1, 2, 3	Complied
Left Hand Side of EUT Facing Phantom	Flat (SAM)	6	0.013	1.600	1.587	1, 2, 3	Complied
Right Hand Side of EUT Facing Phantom	Flat (SAM)	6	0.005	1.600	1.595	1, 2, 3	Complied
Top of EUT Facing Phantom	Flat (SAM)	6	0.063	1.600	1.537	1, 2, 3	Complied
Rear of EUT Facing Phantom	Flat (SAM)	6	0.088	1.600	1.512	1, 2, 4	Complied
Rear of EUT Facing Phantom	Flat (SAM)	6	0.094	1.600	1.506	1, 2, 5	Complied
Rear of EUT Facing Phantom With PHF	Flat (SAM)	6	0.155	1.600	1.445	1, 2, 3	Complied

Note(s):

1. EUT supports Hotspot: As per FCC KDB procedure SAR measurements were performed with the EUT at a separation distance of 10mm from the 'SAM' phantom flat section.
2. SAR test was performed in the middle channel only as the measured levels were < 50% of the SAR limit as stated in the FCC Public Notice DA 02-1438 by the SCC-34/SC-2.
3. 802.11b 1Mbps
4. 802.11g 6Mbps
5. 802.11n 6.5Mbps

7.2.18. Conducted Average Power Measurement 2G GSM - Measured Average Power:

Channel Number	Frequency (MHZ)	Power before Test (dBm)	Note
128	824.2	32.6	Conducted
189	836.4	32.5	Conducted
251	848.8	32.5	Conducted
512	1850.2	29.6	Conducted
660	1879.8	29.6	Conducted
810	1909.8	29.6	Conducted

GPRS - Measured Average Power Without consideration for Uplink time slots:

Channel Number	Frequency (MHZ)	Power before Test (dBm) 1Uplink	Power before Test (dBm) 2Uplink	Power before Test (dBm) 3Uplink	Power before Test (dBm) 4Uplink	Note
128	824.2	32.5	30.1	28.4	27.3	Conducted
189	836.4	32.4	30.1	28.3	27.2	Conducted
251	848.8	32.4	30.1	28.4	27.2	Conducted
512	1850.2	29.5	27.3	25.5	24.3	Conducted
660	1879.8	29.5	27.2	25.5	24.3	Conducted
810	1909.8	29.5	27.3	25.6	24.4	Conducted

GPRS - Calculated Value with consideration for Uplink time slots:

Channel Number	Frequency (MHZ)	Power before Test (dBm) 1Uplink	Power before Test (dBm) 2Uplink	Power before Test (dBm) 3Uplink	Power before Test (dBm) 4Uplink	Note
128	824.2	23.5	24.1	24.1	24.3	Conducted
189	836.4	23.4	24.1	24.1	24.2	Conducted
251	848.8	23.4	24.1	24.1	24.2	Conducted
512	1850.2	20.5	21.3	21.2	21.3	Conducted
660	1879.8	20.5	21.2	21.2	21.3	Conducted
810	1909.8	20.5	21.3	21.3	21.4	Conducted

Scale factor for uplink time slot:

- 1 Uplink: time slot ratio = 8:1 => $10 \cdot \log(8/1) = 9.03$ dB
- 2 Uplink: time slot ratio = 8:2 => $10 \cdot \log(8/2) = 6.02$ dB
- 3 Uplink: time slot ratio = 8:3 => $10 \cdot \log(8/3) = 4.26$ dB
- 4 Uplink: time slot ratio = 8:4 => $10 \cdot \log(8/4) = 3.01$ dB

EDGE - Measured Average Power Without consideration for Uplink time slots:

Channel Number	Frequency (MHZ)	Power before Test (dBm) 1Uplink	Power before Test (dBm) 2Uplink	Power before Test (dBm) 3Uplink	Power before Test (dBm) 4Uplink	Note
128	824.2	32.5	30.2	28.4	27.3	Conducted
189	836.4	32.4	30.1	28.3	27.2	Conducted
251	848.8	32.4	30.1	28.3	27.3	Conducted
512	1850.2	29.5	27.3	25.6	24.3	Conducted
660	1879.8	29.5	27.2	25.5	24.3	Conducted
810	1909.8	29.5	27.3	25.6	24.4	Conducted

EDGE - Calculated Value With consideration for Uplink time slots:

Channel Number	Frequency (MHZ)	Power before Test (dBm) 1Uplink	Power before Test (dBm) 2Uplink	Power before Test (dBm) 3Uplink	Power before Test (dBm) 4Uplink	Note
128	824.2	23.5	24.2	24.1	24.3	Conducted
189	836.4	23.4	24.1	24.0	24.2	Conducted
251	848.8	23.4	24.1	24.0	24.3	Conducted
512	1850.2	20.5	21.3	21.3	21.3	Conducted
660	1879.8	20.5	21.2	21.2	21.3	Conducted
810	1909.8	20.5	21.3	21.3	21.4	Conducted

Note:**Scale factor for uplink time slot:**

- 1 Uplink: time slot ratio = 8:1 => $10 \cdot \log(8/1) = 9.03 \text{ dB}$
- 2 Uplink: time slot ratio = 8:2 => $10 \cdot \log(8/2) = 6.02 \text{ dB}$
- 3 Uplink: time slot ratio = 8:3 => $10 \cdot \log(8/3) = 4.26 \text{ dB}$
- 4 Uplink: time slot ratio = 8:4 => $10 \cdot \log(8/4) = 3.01 \text{ dB}$

7.2.19. Conducted Average Power Measurement 3G

Modes		HSDPA				HSPA					WCDMA
Sets		1	2	3	4	1	2	3	4	5	Voice / RMC 12.2kbps
Band	Channel	Power [dBm]	Power [dBm]	Power [dBm]	Power [dBm]	Power [dBm]	Power [dBm]	Power [dBm]	Power [dBm]	Power [dBm]	Power [dBm]
850	4132	22.8	22.0	21.2	21.2	21.5	22.4	20.8	22.9	21.4	23.3
	4357										
	4183	22.8	22.0	21.2	21.2	21.5	22.3	20.8	22.9	21.4	23.3
	4408										
	4233	22.7	21.9	21.2	21.2	21.5	22.3	20.8	22.9	21.3	23.3
	4458										
β_c		2	12	15	15	11	6	15	2	15	
β_d		15	15	8	4	15	15	9	15	15	
$\Delta_{ACK}, \Delta_{NACK}, \Delta_{CQI}$		8	8	8	8	8	8	8	8	8	
AGV		-	-	-	-	20	12	15	17	21	

* Prior to commencement of SAR testing the module power levels were measured in both HSPA and 3G RMC 12.2kbps modes and compared to ensure the correct mode of operation had been established.

The following tables taken from FCC 3G SAR procedures (KDB 941225 D01 SAR test for 3G devices v02) below were applied using an Agilent 8960 series 10 wireless communications test set which supports 3G / HSDPA release 5 / HSPA release 6.

Sub-test 1 Setup for Release 5 HSDPA

Sub-test	β_c	β_d	B_d (SF)	β_c/β_d	$\beta_{hs}^{(1)}$	SM (dB) ⁽²⁾
1	2/15	15/15	64	2/15	4/15	0.0
2	12/15 ⁽³⁾	15/15 ⁽³⁾	64	12/15 ⁽³⁾	24/15	1.0
3	15/15	8/15	64	15/8	30/15	1.5
4	15/15	4/15	64	15/4	30/15	1.5

Note 1: $\Delta_{ACK}, \Delta_{NACK}$ and $\Delta_{CQI} = 8 \Leftrightarrow A_{hs} = \beta_{hs}/\beta_c = 30/15 \Leftrightarrow \beta_{hs} = 30/15 * \beta_c$

Note 2: CM = 1 for $\beta_c/\beta_d = 12/15, B_{hs}/\beta_c = 24/15$

Note 3: For subtest 2 the β_c/β_d ratio of 12/15 for the TFC during the measurement period (TF1, TF0) is achieved by setting the signalled gain factors for the reference TFC (TF1, TF1) to $\beta_c = 11/15$ and $\beta_d = 15/15$

Sub-test 5 Setup for Release 6 HSPA

Sub-test	β_c	β_d	B_d (SF)	β_c/β_d	$\beta_{hs}^{(1)}$	B_{oc}	B_{od}	B_{od} (SF)	B_{od} (codes)	CM ⁽²⁾ (dB)	MPR (dB)	AG ⁽⁴⁾ Index	E-TFCI
1	11/15 ⁽³⁾	15/15 ⁽³⁾	64	11/15 ⁽³⁾	22/15	209/225	1039/225	4	1	1.0	0.0	20	75
2	6/15	15/15	64	6/15	12/15	12/15	94/75	4	1	3.0	2.0	12	67
3	15/15	9/15	64	15/9	30/15	31/15	$B_{al1}: 47/15$ $B_{al2}: 47/15$	4	1	2.0	1.0	15	92
4	2/15	15/15	64	2/15	2/15	2/15	56/75	4	1	3.0	2.0	17	71
5	15/15 ⁽⁴⁾	15/15 ⁽⁴⁾	64	15/15 ⁽⁴⁾	24/15	24/15	134/15	4	1	1.0	0.0	21	81

Note 1: $\Delta_{ACK}, \Delta_{NACK}$ and $\Delta_{CQI} = 8 \Leftrightarrow A_{hs} = \beta_{hs}/\beta_c = 30/15 \Leftrightarrow \beta_{hs} = 30/15 * \beta_c$

Note 2: CM = 1 for $\beta_c/\beta_d = 12/15, B_{hs}/\beta_c = 24/15$. For all other combinations of DPDCH, DPCCH, HS-DPCCH, E-DPDCH AND E-DPCCH for the MPR is based on the relative CM difference.

Note 3: For subtest 1 the β_c/β_d ratio of 11/15 for the TFC during the measurement period (TF1, TF0) is achieved by setting the signalled gain factors for the reference TFC (TF1, TF1) to $\beta_c = 10/15$ and $\beta_d = 15/15$.

Note 4: For subtest 5 the β_c/β_d ratio of 15/15 for the TFC during the measurement period (TF1, TF0) is achieved by setting the signalled gain factors for the reference TFC (TF1, TF1) to $\beta_c = 14/15$ and $\beta_d = 15/15$.

Note 5: Testing UE using E-DPDCH Physical Layer category 1 Sub-test 3 is not required according to TS 25.306 Table 5.1g.

Note 6: B_{od} can not be set directly; it is set by Absolute Grant Value.

7.2.20. Conducted Power Measurements Wi-Fi 802.11b/g/n 802.11b/g

Channel Number	Frequency (MHZ)	TX Power before Test (dBm)	Note
1	2412	14.4	2.4GHz 802.11b (1Mbps)
6	2437	14.7	
11	2462	14.6	
1	2412	14.0	2.4GHz 802.11b (11Mbps)
6	2437	14.2	
11	2462	14.1	
1	2412	12.9	2.4GHz 802.11g (6Mbps)
6	2437	13.3	
11	2462	13.1	
1	2412	11.9	2.4GHz 802.11g (54Mbps)
6	2437	12.2	
11	2462	12.2	

802.11n

Channel Number	Frequency (MHZ)	TX Power before Test (dBm)	Note
1	2412	12.7	2.4GHz 802.11n (MCS0 6.5Mbps)
6	2437	13.1	
11	2462	13.0	
1	2412	10.8	2.4GHz 802.11n (MCS7 65Mbps)
6	2437	11.2	
11	2462	11.1	

8. Measurement Uncertainty

No measurement or test can ever be perfect and the imperfections give rise to error of measurement in the results. Consequently, the result of a measurement is only an approximation to the value of the measurand (the specific quantity subject to measurement) and is only complete when accompanied by a statement of the uncertainty of the approximation.

The expression of uncertainty of a measurement result allows realistic comparison of results with reference values and limits given in specifications and standards.

The uncertainty of the result may need to be taken into account when interpreting the measurement results.

The reported expanded uncertainties below are based on a standard uncertainty multiplied by an appropriate coverage factor, such that a confidence level of approximately 95% is maintained. For the purposes of this document “approximately” is interpreted as meaning “effectively” or “for most practical purposes”.

Test Name	Confidence Level	Calculated Uncertainty
Specific Absorption Rate-GSM / GPRS / EDGE 850 UMTS FDD V Head Configuration 1g	95%	19.94
Specific Absorption Rate-GSM / GPRS / EDGE 850 / UMTS-FDD V Body Configuration 1g	95%	20.07
Specific Absorption Rate-PCS / GPRS / EDGE 1900 Head Configuration 1g	95%	20.72
Specific Absorption Rate-PCS / GPRS / EDGE 1900 Body Configuration 1g	95%	20.00
Specific Absorption Rate-Wi-Fi 2450 Head Configuration 1g	95%	19.47
Specific Absorption Rate-Wi-Fi 2450 Body Configuration 1g	95%	19.90

The methods used to calculate the above uncertainties are in line with those recommended within the various measurement specifications. Where measurement specifications do not include guidelines for the evaluation of measurement uncertainty, the published guidance of the appropriate accreditation body is followed.

8.1. Specific Absorption Rate - GSM / GPRS / EDGE 850 / UMTS FDD V Head Configuration 1g

Type	Source of uncertainty	+ Value	- Value	Probability Distribution	Divisor	C _i (10g)	Standard Uncertainty		U _i or U _{eff}
							+ u (%)	- u (%)	
B	Probe calibration	6.000	6.000	normal (k=1)	1.0000	1.0000	6.000	6.000	∞
B	Axial Isotropy	0.250	0.250	normal (k=1)	1.0000	1.0000	0.250	0.250	∞
B	Hemispherical Isotropy	1.300	1.300	normal (k=1)	1.0000	1.0000	1.300	1.300	∞
B	Spatial Resolution	0.500	0.500	Rectangular	1.7321	1.0000	0.289	0.289	∞
B	Boundary Effect	0.769	0.769	Rectangular	1.7321	1.0000	0.444	0.444	∞
B	Linearity	0.600	0.600	Rectangular	1.7321	1.0000	0.346	0.346	∞
B	Detection Limits	0.200	0.200	Rectangular	1.7321	1.0000	0.115	0.115	∞
B	Readout Electronics	0.160	0.160	normal (k=1)	1.0000	1.0000	0.160	0.160	∞
B	Response Time	0.000	0.000	Rectangular	1.7321	1.0000	0.000	0.000	∞
B	Integration Time	1.730	1.730	Rectangular	1.7321	1.0000	0.999	0.999	∞
B	RF Ambient conditions	3.000	3.000	Rectangular	1.7321	1.0000	1.732	1.732	∞
B	Probe Positioner Mechanical Restrictions	4.000	4.000	Rectangular	1.7321	1.0000	2.309	2.309	∞
B	Probe Positioning with regard to Phantom Shell	2.850	2.850	Rectangular	1.7321	1.0000	1.645	1.645	∞
B	Extrapolation and integration / Maximum SAR evaluation	5.080	5.080	Rectangular	1.7321	1.0000	2.933	2.933	∞
A	Test Sample Positioning	2.400	2.400	normal (k=1)	1.0000	1.0000	2.400	2.400	10
A	Device Holder uncertainty	0.154	0.154	normal (k=1)	1.0000	1.0000	0.154	0.154	10
B	Phantom Uncertainty	4.000	4.000	Rectangular	1.7321	1.0000	2.309	2.309	∞
B	Drift of output power	5.000	5.000	Rectangular	1.7321	1.0000	2.887	2.887	∞
B	Liquid Conductivity (target value)	5.000	5.000	Rectangular	1.7321	0.6400	1.848	1.848	∞
A	Liquid Conductivity (measured value)	4.920	4.920	normal (k=1)	1.0000	0.6400	3.149	3.149	5
B	Liquid Permittivity (target value)	5.000	5.000	Rectangular	1.7321	0.6000	1.732	1.732	∞
A	Liquid Permittivity (measured value)	4.970	4.970	normal (k=1)	1.0000	0.6000	2.982	2.982	5
	Combined standard uncertainty			t-distribution			10.17	10.17	>250
	Expanded uncertainty			k = 1.96			19.94	19.94	>250

8.2. Specific Absorption Rate -GSM / GPRS / EDGE 850 / UMTS-FDD V Body Configuration 1g

Type	Source of uncertainty	+ Value	- Value	Probability Distribution	Divisor	C _i (10g)	Standard Uncertainty		U _i or U _{eff}
							+ u (%)	- u (%)	
B	Probe calibration	6.000	6.000	normal (k=1)	1.0000	1.0000	6.000	6.000	∞
B	Axial Isotropy	0.250	0.250	normal (k=1)	1.0000	1.0000	0.250	0.250	∞
B	Hemispherical Isotropy	1.300	1.300	normal (k=1)	1.0000	1.0000	1.300	1.300	∞
B	Spatial Resolution	0.500	0.500	Rectangular	1.7321	1.0000	0.289	0.289	∞
B	Boundary Effect	0.769	0.769	Rectangular	1.7321	1.0000	0.444	0.444	∞
B	Linearity	0.600	0.600	Rectangular	1.7321	1.0000	0.346	0.346	∞
B	Detection Limits	0.200	0.200	Rectangular	1.7321	1.0000	0.115	0.115	∞
B	Readout Electronics	0.160	0.160	normal (k=1)	1.0000	1.0000	0.160	0.160	∞
B	Response Time	0.000	0.000	Rectangular	1.7321	1.0000	0.000	0.000	∞
B	Integration Time	1.730	1.730	Rectangular	1.7321	1.0000	0.999	0.999	∞
B	RF Ambient conditions	3.000	3.000	Rectangular	1.7321	1.0000	1.732	1.732	∞
B	Probe Positioner Mechanical Restrictions	4.000	4.000	Rectangular	1.7321	1.0000	2.309	2.309	∞
B	Probe Positioning with regard to Phantom Shell	2.850	2.850	Rectangular	1.7321	1.0000	1.645	1.645	∞
B	Extrapolation and integration /Maximum SAR evaluation	5.080	5.080	Rectangular	1.7321	1.0000	2.933	2.933	∞
A	Test Sample Positioning	2.900	2.900	normal (k=1)	1.0000	1.0000	2.900	2.900	10
A	Device Holder uncertainty	0.154	0.154	normal (k=1)	1.0000	1.0000	0.154	0.154	10
B	Phantom Uncertainty	4.000	4.000	Rectangular	1.7321	1.0000	2.309	2.309	∞
B	Drift of output power	5.000	5.000	Rectangular	1.7321	1.0000	2.887	2.887	∞
B	Liquid Conductivity (target value)	5.000	5.000	Rectangular	1.7321	0.6400	1.848	1.848	∞
A	Liquid Conductivity (measured value)	4.690	4.690	normal (k=1)	1.0000	0.6400	3.002	3.002	5
B	Liquid Permittivity (target value)	5.000	5.000	Rectangular	1.7321	0.6000	1.732	1.732	∞
A	Liquid Permittivity (measured value)	4.860	4.860	normal (k=1)	1.0000	0.6000	2.916	2.916	5
	Combined standard uncertainty			t-distribution			10.24	10.24	>250
	Expanded uncertainty			k = 1.96			20.07	20.07	>250

8.3. Specific Absorption Rate - PCS / GPRS / EDGE 1900 Head Configuration 1g

Type	Source of uncertainty	+ Value	- Value	Probability Distribution	Divisor	C _i (10g)	Standard Uncertainty		U _i or U _{eff}
							+ u (%)	- u (%)	
B	Probe calibration	6.000	6.000	normal (k=1)	1.0000	1.0000	6.000	6.000	∞
B	Axial Isotropy	0.250	0.250	normal (k=1)	1.0000	1.0000	0.250	0.250	∞
B	Hemispherical Isotropy	1.300	1.300	normal (k=1)	1.0000	1.0000	1.300	1.300	∞
B	Spatial Resolution	0.500	0.500	Rectangular	1.7321	1.0000	0.289	0.289	∞
B	Boundary Effect	0.769	0.769	Rectangular	1.7321	1.0000	0.444	0.444	∞
B	Linearity	0.600	0.600	Rectangular	1.7321	1.0000	0.346	0.346	∞
B	Detection Limits	0.200	0.200	Rectangular	1.7321	1.0000	0.115	0.115	∞
B	Readout Electronics	0.160	0.160	normal (k=1)	1.0000	1.0000	0.160	0.160	∞
B	Response Time	0.000	0.000	Rectangular	1.7321	1.0000	0.000	0.000	∞
B	Integration Time	1.730	1.730	Rectangular	1.7321	1.0000	0.999	0.999	∞
B	RF Ambient conditions	3.000	3.000	Rectangular	1.7321	1.0000	1.732	1.732	∞
B	Probe Positioner Mechanical Restrictions	4.000	4.000	Rectangular	1.7321	1.0000	2.309	2.309	∞
B	Probe Positioning with Regard to Phantom Shell	2.850	2.850	Rectangular	1.7321	1.0000	1.645	1.645	∞
B	Extrapolation and integration / Maximum SAR evaluation	5.080	5.080	Rectangular	1.7321	1.0000	2.933	2.933	∞
A	Test Sample Positioning	3.800	3.800	normal (k=1)	1.0000	1.0000	3.800	3.800	10
A	Device Holder uncertainty	0.154	0.154	normal (k=1)	1.0000	1.0000	0.154	0.154	10
B	Phantom Uncertainty	4.000	4.000	Rectangular	1.7321	1.0000	2.309	2.309	∞
B	Drift of output power	5.000	5.000	Rectangular	1.7321	1.0000	2.887	2.887	∞
B	Liquid Conductivity (target value)	5.000	5.000	Rectangular	1.7321	0.6400	1.848	1.848	∞
A	Liquid Conductivity (measured value)	4.900	4.900	normal (k=1)	1.0000	0.6400	3.136	3.136	5
B	Liquid Permittivity (target value)	5.000	5.000	Rectangular	1.7321	0.6000	1.732	1.732	∞
A	Liquid Permittivity (measured value)	4.880	4.880	normal (k=1)	1.0000	0.6000	2.928	2.928	5
	Combined standard uncertainty			t-distribution			10.57	10.57	>200
	Expanded uncertainty			k = 1.96			20.72	20.72	>200

8.4. Specific Absorption Rate - PCS / GPRS / EDGE1900 Body Configuration 1g

Type	Source of uncertainty	+ Value	- Value	Probability Distribution	Divisor	C _i (10g)	Standard Uncertainty		U _i or U _{eff}
							+ u (%)	- u (%)	
B	Probe calibration	6.000	6.000	normal (k=1)	1.0000	1.0000	6.000	6.000	∞
B	Axial Isotropy	0.250	0.250	normal (k=1)	1.0000	1.0000	0.250	0.250	∞
B	Hemispherical Isotropy	1.300	1.300	normal (k=1)	1.0000	1.0000	1.300	1.300	∞
B	Spatial Resolution	0.500	0.500	Rectangular	1.7321	1.0000	0.289	0.289	∞
B	Boundary Effect	0.769	0.769	Rectangular	1.7321	1.0000	0.444	0.444	∞
B	Linearity	0.600	0.600	Rectangular	1.7321	1.0000	0.346	0.346	∞
B	Detection Limits	0.200	0.200	Rectangular	1.7321	1.0000	0.115	0.115	∞
B	Readout Electronics	0.160	0.160	normal (k=1)	1.0000	1.0000	0.160	0.160	∞
B	Response Time	0.000	0.000	Rectangular	1.7321	1.0000	0.000	0.000	∞
B	Integration Time	1.730	1.730	Rectangular	1.7321	1.0000	0.999	0.999	∞
B	RF Ambient conditions	3.000	3.000	Rectangular	1.7321	1.0000	1.732	1.732	∞
B	Probe Positioner Mechanical Restrictions	4.000	4.000	Rectangular	1.7321	1.0000	2.309	2.309	∞
B	Probe Positioning with regard to Phantom Shell	2.850	2.850	Rectangular	1.7321	1.0000	1.645	1.645	∞
B	Extrapolation and integration / Maximum SAR evaluation	5.080	5.080	Rectangular	1.7321	1.0000	2.933	2.933	∞
A	Test Sample Positioning	2.500	2.500	normal (k=1)	1.0000	1.0000	2.500	2.500	10
A	Device Holder uncertainty	0.154	0.154	normal (k=1)	1.0000	1.0000	0.154	0.154	10
B	Phantom Uncertainty	4.000	4.000	Rectangular	1.7321	1.0000	2.309	2.309	∞
B	Drift of output power	5.000	5.000	Rectangular	1.7321	1.0000	2.887	2.887	∞
B	Liquid Conductivity (target value)	5.000	5.000	Rectangular	1.7321	0.6400	1.848	1.848	∞
A	Liquid Conductivity (measured value)	4.940	4.940	normal (k=1)	1.0000	0.6400	3.162	3.162	5
B	Liquid Permittivity (target value)	5.000	5.000	Rectangular	1.7321	0.6000	1.732	1.732	∞
A	Liquid Permittivity (measured value)	4.980	4.980	normal (k=1)	1.0000	0.6000	2.988	2.988	5
	Combined standard uncertainty			t-distribution			10.20	10.20	>250
	Expanded uncertainty			k = 1.96			20.00	20.00	>250

8.5. Specific Absorption Rate - Wi-Fi 2450 Head Configuration 1g

Type	Source of uncertainty	+ Value	- Value	Probability Distribution	Divisor	C _i (10g)	Standard Uncertainty		U _i or U _{eff}
							+ u (%)	- u (%)	
B	Probe calibration	6.000	6.000	normal (k=1)	1.0000	1.0000	6.000	6.000	∞
B	Axial Isotropy	0.250	0.250	normal (k=1)	1.0000	1.0000	0.250	0.250	∞
B	Hemispherical Isotropy	1.300	1.300	normal (k=1)	1.0000	1.0000	1.300	1.300	∞
B	Spatial Resolution	0.500	0.500	Rectangular	1.7321	1.0000	0.289	0.289	∞
B	Boundary Effect	0.769	0.769	Rectangular	1.7321	1.0000	0.444	0.444	∞
B	Linearity	0.600	0.600	Rectangular	1.7321	1.0000	0.346	0.346	∞
B	Detection Limits	0.200	0.200	Rectangular	1.7321	1.0000	0.115	0.115	∞
B	Readout Electronics	0.160	0.160	normal (k=1)	1.0000	1.0000	0.160	0.160	∞
B	Response Time	0.000	0.000	Rectangular	1.7321	1.0000	0.000	0.000	∞
B	Integration Time	0.000	0.000	Rectangular	1.7321	1.0000	0.000	0.000	∞
B	RF Ambient conditions	3.000	3.000	Rectangular	1.7321	1.0000	1.732	1.732	∞
B	Probe Positioner Mechanical Restrictions	4.000	4.000	Rectangular	1.7321	1.0000	2.309	2.309	∞
B	Probe Positioning with regard to Phantom Shell	2.850	2.850	Rectangular	1.7321	1.0000	1.645	1.645	∞
B	Extrapolation and integration / Maximum SAR evaluation	5.080	5.080	Rectangular	1.7321	1.0000	2.933	2.933	∞
A	Test Sample Positioning	2.000	2.000	normal (k=1)	1.0000	1.0000	2.000	2.000	10
A	Device Holder uncertainty	0.154	0.154	normal (k=1)	1.0000	1.0000	0.154	0.154	10
B	Phantom Uncertainty	4.000	4.000	Rectangular	1.7321	1.0000	2.309	2.309	∞
B	Drift of output power	5.000	5.000	Rectangular	1.7321	1.0000	2.887	2.887	∞
B	Liquid Conductivity (target value)	5.000	5.000	Rectangular	1.7321	0.6400	1.848	1.848	∞
A	Liquid Conductivity (measured value)	4.410	4.410	normal (k=1)	1.0000	0.6400	2.822	2.822	5
B	Liquid Permittivity (target value)	5.000	5.000	Rectangular	1.7321	0.6000	1.732	1.732	∞
A	Liquid Permittivity (measured value)	4.930	4.930	normal (k=1)	1.0000	0.6000	2.958	2.958	5
	Combined standard uncertainty			t-distribution			9.93	9.93	>300
	Expanded uncertainty			k = 1.96			19.47	19.47	>300

8.6. Specific Absorption Rate - Wi-Fi 2450 Body Configuration 1g

Type	Source of uncertainty	+ Value	- Value	Probability Distribution	Divisor	C _i (10g)	Standard Uncertainty		U _i or U _{eff}
							+ u (%)	- u (%)	
B	Probe calibration	6.000	6.000	normal (k=1)	1.0000	1.0000	6.000	6.000	∞
B	Axial Isotropy	0.250	0.250	normal (k=1)	1.0000	1.0000	0.250	0.250	∞
B	Hemispherical Isotropy	1.300	1.300	normal (k=1)	1.0000	1.0000	1.300	1.300	∞
B	Spatial Resolution	0.500	0.500	Rectangular	1.7321	1.0000	0.289	0.289	∞
B	Boundary Effect	0.769	0.769	Rectangular	1.7321	1.0000	0.444	0.444	∞
B	Linearity	0.600	0.600	Rectangular	1.7321	1.0000	0.346	0.346	∞
B	Detection Limits	0.200	0.200	Rectangular	1.7321	1.0000	0.115	0.115	∞
B	Readout Electronics	0.160	0.160	normal (k=1)	1.0000	1.0000	0.160	0.160	∞
B	Response Time	0.000	0.000	Rectangular	1.7321	1.0000	0.000	0.000	∞
B	Integration Time	0.000	0.000	Rectangular	1.7321	1.0000	0.000	0.000	∞
B	RF Ambient conditions	3.000	3.000	Rectangular	1.7321	1.0000	1.732	1.732	∞
B	Probe Positioner Mechanical Restrictions	4.000	4.000	Rectangular	1.7321	1.0000	2.309	2.309	∞
B	Probe Positioning with regard to Phantom Shell	2.850	2.850	Rectangular	1.7321	1.0000	1.645	1.645	∞
B	Extrapolation and integration / Maximum SAR evaluation	5.080	5.080	Rectangular	1.7321	1.0000	2.933	2.933	∞
A	Test Sample Positioning	2.570	2.570	normal (k=1)	1.0000	1.0000	2.570	2.570	10
A	Device Holder uncertainty	0.154	0.154	normal (k=1)	1.0000	1.0000	0.154	0.154	10
B	Phantom Uncertainty	4.000	4.000	Rectangular	1.7321	1.0000	2.309	2.309	∞
B	Drift of output power	5.000	5.000	Rectangular	1.7321	1.0000	2.887	2.887	∞
B	Liquid Conductivity (target value)	5.000	5.000	Rectangular	1.7321	0.6400	1.848	1.848	∞
A	Liquid Conductivity (measured value)	4.900	4.900	normal (k=1)	1.0000	0.6400	3.136	3.136	5
B	Liquid Permittivity (target value)	5.000	5.000	Rectangular	1.7321	0.6000	1.732	1.732	∞
A	Liquid Permittivity (measured value)	4.920	4.920	normal (k=1)	1.0000	0.6000	2.952	2.952	5
	Combined standard uncertainty			t-distribution			10.15	10.15	>250
	Expanded uncertainty			k = 1.96			19.90	19.90	>250

Appendix 1. Test Equipment Used

RFI No.	Instrument	Manufacturer	Type No.	Serial No.	Date Last Calibrated	Cal. Interval (Months)
A034	Narda 20W Termination	Narda	374BNM	8706	Calibrated as part of system	-
A1097	SMA Directional Coupler	MidISCO	MDC6223-30	None	Calibrated as part of system	-
A1137	3dB Attenuator	Narda	779	04690	Calibrated as part of system	-
A1174	Dielectric Probe Kit	Agilent Technologies	85070C	Us99360072	Calibrated before use	-
A1328	Handset Positioner	Schmid & Partner Engineering AG	Modification	SD 000 H01 DA	-	-
A1182	Handset Positioner	Schmid & Partner Engineering AG	V3.0	None	-	-
A1234	Data Acquisition Electronics	Schmid & Partner Engineering AG	DAE3	450	09 Feb 2011	12
A1235	900 MHz Dipole Kit	Schmid & Partner Engineering AG	D900V2	124	09 Feb 2011	24
A1237	1900 MHz Dipole Kit	Schmid & Partner Engineering AG	D1900V2	540	08 Feb 2011	24
A1322	2450 MHz Dipole Kit	Schmid & Partner Engineering AG	D2450V2	725	08 Feb 2011	24
A1238	SAM Phantom	Schmid & Partner Engineering AG	SAM b	001	Calibrated before use	-
A1185	Probe	Schmid & Partner Engineering AG	ET3 DV6	1528	18 Jul 2011	12
A2077	Probe	Schmid & Partner Engineering AG	ET3 DV4	3814	22 Sep 2011	12
A1497	Amplifier	Mini-Circuits	zh1-42w (sma)	e020105	Calibrated as part of system	-
A1566	SAM Phantom	Schmid & Partner Engineering AG	SAM a	002	Calibrated before use	-
A1990	Digital Camera	Samsung	E515	A23WC90 8A05431K	-	-
A215	20 dB Attenuator	Narda	766-20	9402	Calibrated as part of system	-
A1531	Antenna	AARONIA AG	7025	02458	-	-
C1145	Cable	Rosenberger MICRO-COAX	FA147A F003003030	41843-1	Calibrated as part of system	-

RFI No.	Instrument	Manufacturer	Type No.	Serial No.	Date Last Calibrated	Cal. Interval (Months)
C1146	Cable	Rosenberger MICRO-COAX	FA147A F030003030	41752-1	Calibrated as part of system	-
G0528	Robot Power Supply	Schmid & Partner Engineering AG	DASY4	None	Calibrated before use	-
G087	PSU	Thurlby Thandar	CPX200	100701	Calibrated before use	-
M1047	Robot Arm	Staubli	RX908 L	F00/SD8 9A1/A/01	Calibrated before use	-
M1159	Signal Generator	Agilent Technologies	E8241A	US42110332	Internal Checked 15 Dec 2011	4
M1071	Spectrum Analyzer	Agilent	HP8590E	3647U00514	(Monitoring use only)	-
M1044	Diode Power Sensor	Rohde & Schwarz	NRV-Z1	893350/019	26 May 2011	12
M265	Diode Power Sensor	Rohde & Schwarz	NRV-Z1	893350/017	26 May 2011	12
M263	Dual Channel Power Meter	Rohde & Schwarz	NRVD	826558/004	25 May 2011	12
M509	Thermometer	Testo 110 Immersion Probe & Thermometer	Testo 110	03100047	25 May 2011	12
M1270	Digital Thermometer	RS	N/A	N/A	Internal Checked 13 May 2011	12
S256	SAR Lab	RFI	Site 56	N/A	Calibrated before use	-

A.1.1. Calibration Certificates

This section contains the calibration certificates and data for the Probe(s) and Dipole(s) used, which are not included in the total number of pages for this report.

Asset: A1235 Checked by *[Signature]*
21/02/2011

**Calibration Laboratory of
Schmid & Partner
Engineering AG**
Zeughausstrasse 43, 8004 Zurich, Switzerland



S Schweizerischer Kalibrierdienst
C Service suisse d'étalonnage
S Servizio svizzero di taratura
S Swiss Calibration Service

Accredited by the Swiss Accreditation Service (SAS)
The Swiss Accreditation Service is one of the signatories to the EA
Multilateral Agreement for the recognition of calibration certificates

Accreditation No.: **SCS 108**

Client **RFI**

Certificate No: **D900V2-124_Feb11**

CALIBRATION CERTIFICATE

Object **D900V2 - SN: 124**

Calibration procedure(s) **QA CAL-05.v8
Calibration procedure for dipole validation kits**

Calibration date: **February 09, 2011**

This calibration certificate documents the traceability to national standards, which realize the physical units of measurements (SI).
The measurements and the uncertainties with confidence probability are given on the following pages and are part of the certificate.

All calibrations have been conducted in the closed laboratory facility: environment temperature (22 ± 3)°C and humidity < 70%.

Calibration Equipment used (M&TE critical for calibration)

Primary Standards	ID #	Cal Date (Certificate No.)	Scheduled Calibration
Power meter EPM-442A	GB37480704	06-Oct-10 (No. 217-01266)	Oct-11
Power sensor HP 8481A	US37292783	06-Oct-10 (No. 217-01266)	Oct-11
Reference 20 dB Attenuator	SN: 5086 (20g)	30-Mar-10 (No. 217-01158)	Mar-11
Type-N mismatch combination	SN: 5047.2 / 06327	30-Mar-10 (No. 217-01162)	Mar-11
Reference Probe ES3DV3	SN: 3205	30-Apr-10 (No. ES3-3205_Apr10)	Apr-11
DAE4	SN: 601	10-Jun-10 (No. DAE4-601_Jun10)	Jun-11
Secondary Standards	ID #	Check Date (in house)	Scheduled Check
Power sensor HP 8481A	MY41092317	18-Oct-02 (in house check Oct-09)	In house check: Oct-11
RF generator R&S SMT-06	100005	4-Aug-99 (in house check Oct-09)	In house check: Oct-11
Network Analyzer HP 8753E	US37390585 S4206	18-Oct-01 (in house check Oct-10)	In house check: Oct-11

Calibrated by: **Dimce Iliev** (Name), **Laboratory Technician** (Function), *[Signature]* (Signature)

Approved by: **Katja Pokovic** (Name), **Technical Manager** (Function), *[Signature]* (Signature)

Issued: February 9, 2011

This calibration certificate shall not be reproduced except in full without written approval of the laboratory.



Accredited by the Swiss Accreditation Service (SAS)
The Swiss Accreditation Service is one of the signatories to the EA
Multilateral Agreement for the recognition of calibration certificates

Accreditation No.: **SCS 108**

Glossary:

TSL	tissue simulating liquid
ConvF	sensitivity in TSL / NORM x,y,z
N/A	not applicable or not measured

Calibration is Performed According to the Following Standards:

- a) IEEE Std 1528-2003, "IEEE Recommended Practice for Determining the Peak Spatial-Averaged Specific Absorption Rate (SAR) in the Human Head from Wireless Communications Devices: Measurement Techniques", December 2003
- b) IEC 62209-1, "Procedure to measure the Specific Absorption Rate (SAR) for hand-held devices used in close proximity to the ear (frequency range of 300 MHz to 3 GHz)", February 2005
- c) Federal Communications Commission Office of Engineering & Technology (FCC OET), "Evaluating Compliance with FCC Guidelines for Human Exposure to Radiofrequency Electromagnetic Fields; Additional Information for Evaluating Compliance of Mobile and Portable Devices with FCC Limits for Human Exposure to Radiofrequency Emissions", Supplement C (Edition 01-01) to Bulletin 65

Additional Documentation:

- d) DASY4/5 System Handbook

Methods Applied and Interpretation of Parameters:

- *Measurement Conditions:* Further details are available from the Validation Report at the end of the certificate. All figures stated in the certificate are valid at the frequency indicated.
- *Antenna Parameters with TSL:* The dipole is mounted with the spacer to position its feed point exactly below the center marking of the flat phantom section, with the arms oriented parallel to the body axis.
- *Feed Point Impedance and Return Loss:* These parameters are measured with the dipole positioned under the liquid filled phantom. The impedance stated is transformed from the measurement at the SMA connector to the feed point. The Return Loss ensures low reflected power. No uncertainty required.
- *Electrical Delay:* One-way delay between the SMA connector and the antenna feed point. No uncertainty required.
- *SAR measured:* SAR measured at the stated antenna input power.
- *SAR normalized:* SAR as measured, normalized to an input power of 1 W at the antenna connector.
- *SAR for nominal TSL parameters:* The measured TSL parameters are used to calculate the nominal SAR result.

Measurement Conditions

DASY system configuration, as far as not given on page 1.

DASY Version	DASY5	V52.6
Extrapolation	Advanced Extrapolation	
Phantom	Modular Flat Phantom V4.9	
Distance Dipole Center - TSL	15 mm	with Spacer
Zoom Scan Resolution	dx, dy, dz = 5 mm	
Frequency	900 MHz ± 1 MHz	

Head TSL parameters

The following parameters and calculations were applied.

	Temperature	Permittivity	Conductivity
Nominal Head TSL parameters	22.2 °C	41.5	0.97 mho/m
Measured Head TSL parameters	(22.0 ± 0.2) °C	40.3 ± 6 %	0.95 mho/m ± 6 %
Head TSL temperature during test	(21.5 ± 0.2) °C	----	----

SAR result with Head TSL

SAR averaged over 1 cm ³ (1 g) of Head TSL	Condition	
SAR measured	250 mW input power	2.72 mW / g
SAR normalized	normalized to 1W	10.9 mW / g
SAR for nominal Head TSL parameters	normalized to 1W	11.0 mW /g ± 17.0 % (k=2)

SAR averaged over 10 cm ³ (10 g) of Head TSL	condition	
SAR measured	250 mW input power	1.74 mW / g
SAR normalized	normalized to 1W	6.96 mW / g
SAR for nominal Head TSL parameters	normalized to 1W	7.01 mW /g ± 16.5 % (k=2)

Body TSL parameters

The following parameters and calculations were applied.

	Temperature	Permittivity	Conductivity
Nominal Body TSL parameters	22.0 °C	55.0	1.05 mho/m
Measured Body TSL parameters	(22.0 ± 0.2) °C	53.6 ± 6 %	1.05 mho/m ± 6 %
Body TSL temperature during test	(21.8 ± 0.2) °C	----	----

SAR result with Body TSL

SAR averaged over 1 cm³ (1 g) of Body TSL	Condition	
SAR measured	250 mW input power	2.79 mW / g
SAR normalized	normalized to 1W	11.2 mW / g
SAR for nominal Body TSL parameters	normalized to 1W	11.1 mW / g ± 17.0 % (k=2)

SAR averaged over 10 cm³ (10 g) of Body TSL	condition	
SAR measured	250 mW input power	1.79 mW / g
SAR normalized	normalized to 1W	7.16 mW / g
SAR for nominal Body TSL parameters	normalized to 1W	7.14 mW / g ± 16.5 % (k=2)

Appendix

Antenna Parameters with Head TSL

Impedance, transformed to feed point	48.9 Ω - 8.2 j Ω
Return Loss	- 21.6 dB

Antenna Parameters with Body TSL

Impedance, transformed to feed point	46.1 Ω - 8.6 j Ω
Return Loss	- 20.2 dB

General Antenna Parameters and Design

Electrical Delay (one direction)	1.409 ns
----------------------------------	----------

After long term use with 100W radiated power, only a slight warming of the dipole near the feedpoint can be measured.

The dipole is made of standard semirigid coaxial cable. The center conductor of the feeding line is directly connected to the second arm of the dipole. The antenna is therefore short-circuited for DC-signals.

No excessive force must be applied to the dipole arms, because they might bend or the soldered connections near the feedpoint may be damaged.

Additional EUT Data

Manufactured by	SPEAG
Manufactured on	July 04, 2001

DASY5 Validation Report for Head TSL

Date/Time: 09.02.2011 11:44:15

Test Laboratory: SPEAG, Zurich, Switzerland

DUT: Dipole 900 MHz; Type: D900V2; Serial: D900V2 - SN:124

Communication System: CW; Frequency: 900 MHz; Duty Cycle: 1:1

Medium: HSL900

Medium parameters used: $f = 900$ MHz; $\sigma = 0.95$ mho/m; $\epsilon_r = 40.3$; $\rho = 1000$ kg/m³

Phantom section: Flat Section

Measurement Standard: DASY5 (IEEE/IEC/ANSI C63.19-2007)

DASY5 Configuration:

- Probe: ES3DV3 - SN3205; ConvF(5.88, 5.88, 5.88); Calibrated: 30.04.2010
- Sensor-Surface: 3mm (Mechanical Surface Detection)
- Electronics: DAE4 Sn601; Calibrated: 10.06.2010
- Phantom: Flat Phantom 4.9L; Type: QD000P49AA; Serial: 1001
- Measurement SW: DASY52, V52.6.1 Build (408)
- Postprocessing SW: SEMCAD X, V14.4.2 Build (2595)

Pin=250 mW /d=15mm, dist=3.0mm (ES-Probe)/Zoom Scan (7x7x7) /Cube 0: Measurement grid: dx=5mm, dy=5mm, dz=5mm

Reference Value = 59.560 V/m; Power Drift = 0.03 dB

Peak SAR (extrapolated) = 4.135 W/kg

SAR(1 g) = 2.72 mW/g; SAR(10 g) = 1.74 mW/g

Maximum value of SAR (measured) = 3.183 mW/g

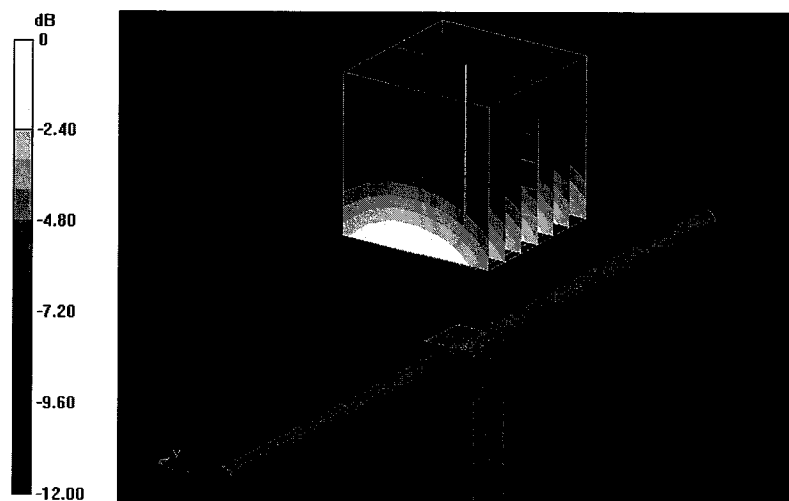

0 dB = 3.180mW/g

Impedance Measurement Plot for Head TSL

9 Feb 2011 10:21:37

CH1 S11 1 U FS 2: 48.854 Ω -8.1758 Ω 21.630 pF 900.000 000 MHz

*
Del
Cor

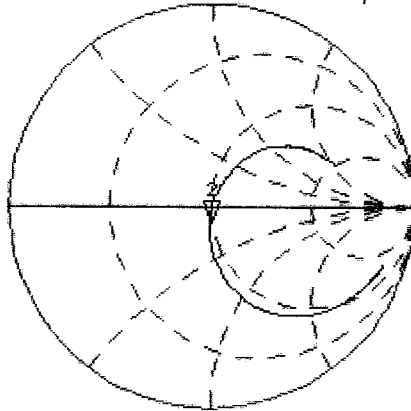

Avg
16

↑

CH2 S11 LOG 5 dB/REF -20 dB 2: -21.595 dB 900.000 000 MHz

Cor

Avg
16

↑

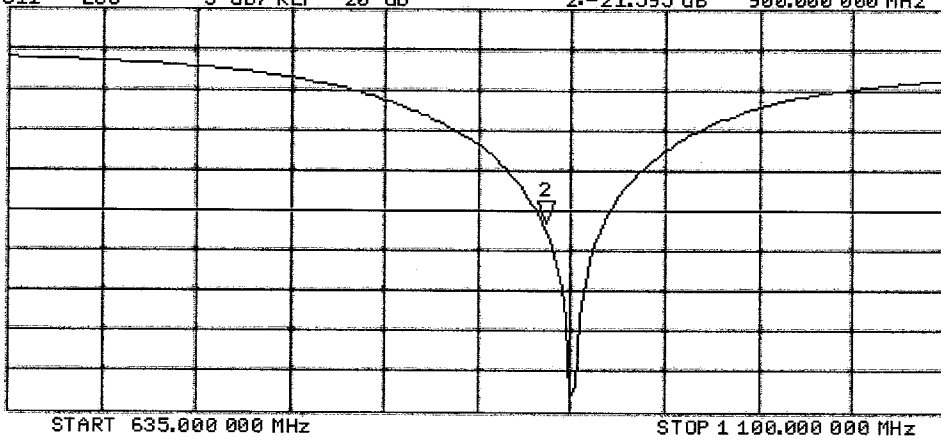

DASY5 Validation Report for Body TSL

Date/Time: 09.02.2011 14:54:48

Test Laboratory: SPEAG, Zurich, Switzerland

DUT: Dipole 900 MHz; Type: D900V2; Serial: D900V2 - SN:124

Communication System: CW; Frequency: 900 MHz; Duty Cycle: 1:1

Medium: M900

Medium parameters used: $f = 900$ MHz; $\sigma = 1.05$ mho/m; $\epsilon_r = 53.6$; $\rho = 1000$ kg/m³

Phantom section: Flat Section

Measurement Standard: DASY5 (IEEE/IEC/ANSI C63.19-2007)

DASY5 Configuration:

- Probe: ES3DV3 - SN3205; ConvF(5.81, 5.81, 5.81); Calibrated: 30.04.2010
- Sensor-Surface: 3mm (Mechanical Surface Detection)
- Electronics: DAE4 Sn601; Calibrated: 10.06.2010
- Phantom: Flat Phantom 4.9L; Type: QD000P49AA; Serial: 1001
- Measurement SW: DASY52, V52.6.1 Build (408)
- Postprocessing SW: SEMCAD X, V14.4.2 Build (2595)

Pin=250 mW /d=15mm, dist=3.0mm (ES-Probe)/Zoom Scan (7x7x7) /Cube 0: Measurement grid: dx=5mm, dy=5mm, dz=5mm

Reference Value = 57.520 V/m; Power Drift = 0.01 dB

Peak SAR (extrapolated) = 4.203 W/kg

SAR(1 g) = 2.79 mW/g; SAR(10 g) = 1.79 mW/g

Maximum value of SAR (measured) = 3.271 mW/g

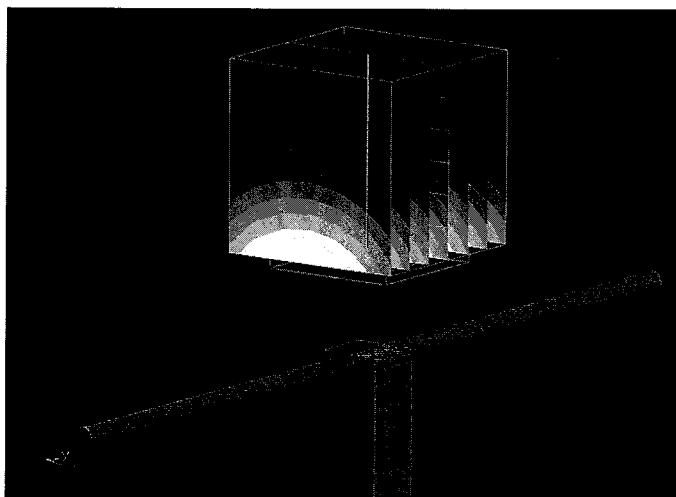

0 dB = 3.270mW/g

Impedance Measurement Plot for Body TSL

9 Feb 2011 14:24:47

CH1 S11 1 U FS Z: 46.072 Ω -8.6230 Ω 20.508 pF 900.000 000 MHz

*
De1
Cor

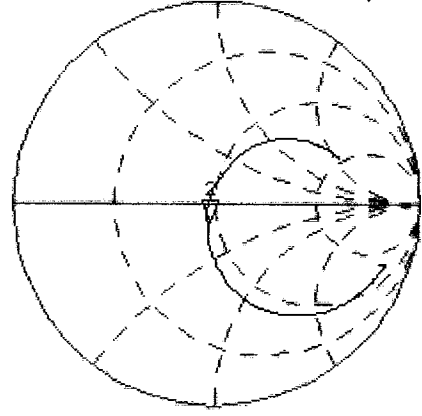

Avg
16
↑

CH2 S11 LOG 5 dB/REF -20 dB Z: -20.156 dB 900.000 000 MHz

Cor
Avg
16
↑

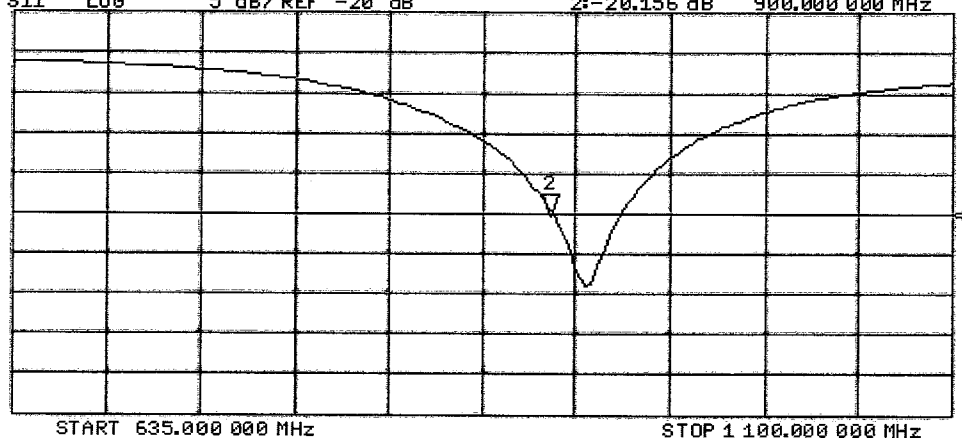

ASSET: A/237 - checked by *[Signature]*
21/02/2011

**Calibration Laboratory of
Schmid & Partner
Engineering AG**
Zeughausstrasse 43, 8004 Zurich, Switzerland



S Schweizerischer Kalibrierdienst
C Service suisse d'étalonnage
S Servizio svizzero di taratura
S Swiss Calibration Service

Accredited by the Swiss Accreditation Service (SAS)
The Swiss Accreditation Service is one of the signatories to the EA
Multilateral Agreement for the recognition of calibration certificates

Accreditation No.: **SCS 108**

Client **RFI**

Certificate No: **D1900V2-540_Feb11**

CALIBRATION CERTIFICATE

Object **D1900V2 - SN: 540**

Calibration procedure(s) **QA CAL-05.v8
Calibration procedure for dipole validation kits**

Calibration date: **February 08, 2011**

This calibration certificate documents the traceability to national standards, which realize the physical units of measurements (SI).
The measurements and the uncertainties with confidence probability are given on the following pages and are part of the certificate.

All calibrations have been conducted in the closed laboratory facility: environment temperature (22 ± 3)°C and humidity < 70%.

Calibration Equipment used (M&TE critical for calibration)

Primary Standards	ID #	Cal Date (Certificate No.)	Scheduled Calibration
Power meter EPM-442A	GB37480704	06-Oct-10 (No. 217-01266)	Oct-11
Power sensor HP 8481A	US37292783	06-Oct-10 (No. 217-01266)	Oct-11
Reference 20 dB Attenuator	SN: 5086 (20g)	30-Mar-10 (No. 217-01158)	Mar-11
Type-N mismatch combination	SN: 5047.2 / 06327	30-Mar-10 (No. 217-01162)	Mar-11
Reference Probe ES3DV3	SN: 3205	30-Apr-10 (No. ES3-3205_Apr10)	Apr-11
DAE4	SN: 601	10-Jun-10 (No. DAE4-601_Jun10)	Jun-11
Secondary Standards	ID #	Check Date (in house)	Scheduled Check
Power sensor HP 8481A	MY41092317	18-Oct-02 (in house check Oct-09)	In house check: Oct-11
RF generator R&S SMT-06	100005	4-Aug-99 (in house check Oct-09)	In house check: Oct-11
Network Analyzer HP 8753E	US37390585 S4206	18-Oct-01 (in house check Oct-10)	In house check: Oct-11

Calibrated by: **Dimce Iliev** (Name), **Laboratory Technician** (Function), *[Signature]* (Signature)

Approved by: **Katja Pokovic** (Name), **Technical Manager** (Function), *[Signature]* (Signature)

Issued: February 8, 2011

This calibration certificate shall not be reproduced except in full without written approval of the laboratory.



Accredited by the Swiss Accreditation Service (SAS)
The Swiss Accreditation Service is one of the signatories to the EA
Multilateral Agreement for the recognition of calibration certificates

Accreditation No.: **SCS 108**

Glossary:

TSL	tissue simulating liquid
ConvF	sensitivity in TSL / NORM x,y,z
N/A	not applicable or not measured

Calibration is Performed According to the Following Standards:

- a) IEEE Std 1528-2003, "IEEE Recommended Practice for Determining the Peak Spatial-Averaged Specific Absorption Rate (SAR) in the Human Head from Wireless Communications Devices: Measurement Techniques", December 2003
- b) IEC 62209-1, "Procedure to measure the Specific Absorption Rate (SAR) for hand-held devices used in close proximity to the ear (frequency range of 300 MHz to 3 GHz)", February 2005
- c) Federal Communications Commission Office of Engineering & Technology (FCC OET), "Evaluating Compliance with FCC Guidelines for Human Exposure to Radiofrequency Electromagnetic Fields; Additional Information for Evaluating Compliance of Mobile and Portable Devices with FCC Limits for Human Exposure to Radiofrequency Emissions", Supplement C (Edition 01-01) to Bulletin 65

Additional Documentation:

- d) DASY4/5 System Handbook

Methods Applied and Interpretation of Parameters:

- *Measurement Conditions:* Further details are available from the Validation Report at the end of the certificate. All figures stated in the certificate are valid at the frequency indicated.
- *Antenna Parameters with TSL:* The dipole is mounted with the spacer to position its feed point exactly below the center marking of the flat phantom section, with the arms oriented parallel to the body axis.
- *Feed Point Impedance and Return Loss:* These parameters are measured with the dipole positioned under the liquid filled phantom. The impedance stated is transformed from the measurement at the SMA connector to the feed point. The Return Loss ensures low reflected power. No uncertainty required.
- *Electrical Delay:* One-way delay between the SMA connector and the antenna feed point. No uncertainty required.
- *SAR measured:* SAR measured at the stated antenna input power.
- *SAR normalized:* SAR as measured, normalized to an input power of 1 W at the antenna connector.
- *SAR for nominal TSL parameters:* The measured TSL parameters are used to calculate the nominal SAR result.

Measurement Conditions

DASY system configuration, as far as not given on page 1.

DASY Version	DASY5	V52.6
Extrapolation	Advanced Extrapolation	
Phantom	Modular Flat Phantom V5.0	
Distance Dipole Center - TSL	10 mm	with Spacer
Zoom Scan Resolution	dx, dy, dz = 5 mm	
Frequency	1900 MHz \pm 1 MHz	

Head TSL parameters

The following parameters and calculations were applied.

	Temperature	Permittivity	Conductivity
Nominal Head TSL parameters	22.0 °C	40.0	1.40 mho/m
Measured Head TSL parameters	(22.0 \pm 0.2) °C	39.8 \pm 6 %	1.41 mho/m \pm 6 %
Head TSL temperature during test	(21.0 \pm 0.2) °C	----	----

SAR result with Head TSL

SAR averaged over 1 cm³ (1 g) of Head TSL	Condition	
SAR measured	250 mW input power	10.1 mW / g
SAR normalized	normalized to 1W	40.4 mW / g
SAR for nominal Head TSL parameters	normalized to 1W	40.3 mW / g \pm 17.0 % (k=2)

SAR averaged over 10 cm³ (10 g) of Head TSL	condition	
SAR measured	250 mW input power	5.25 mW / g
SAR normalized	normalized to 1W	21.0 mW / g
SAR for nominal Head TSL parameters	normalized to 1W	21.0 mW / g \pm 16.5 % (k=2)

Body TSL parameters

The following parameters and calculations were applied.

	Temperature	Permittivity	Conductivity
Nominal Body TSL parameters	22.0 °C	53.3	1.52 mho/m
Measured Body TSL parameters	(22.0 ± 0.2) °C	52.8 ± 6 %	1.55 mho/m ± 6 %
Body TSL temperature during test	(21.2 ± 0.2) °C	----	----

SAR result with Body TSL

SAR averaged over 1 cm ³ (1 g) of Body TSL	Condition	
SAR measured	250 mW input power	10.3 mW / g
SAR normalized	normalized to 1W	41.2 mW / g
SAR for nominal Body TSL parameters	normalized to 1W	40.7 mW / g ± 17.0 % (k=2)

SAR averaged over 10 cm ³ (10 g) of Body TSL	condition	
SAR measured	250 mW input power	5.43 mW / g
SAR normalized	normalized to 1W	21.7 mW / g
SAR for nominal Body TSL parameters	normalized to 1W	21.6 mW / g ± 16.5 % (k=2)

Appendix

Antenna Parameters with Head TSL

Impedance, transformed to feed point	50.5 Ω + 4.2 j Ω
Return Loss	- 27.6 dB

Antenna Parameters with Body TSL

Impedance, transformed to feed point	45.6 Ω + 5.0 j Ω
Return Loss	- 23.1 dB

General Antenna Parameters and Design

Electrical Delay (one direction)	1.195 ns
----------------------------------	----------

After long term use with 100W radiated power, only a slight warming of the dipole near the feedpoint can be measured.

The dipole is made of standard semirigid coaxial cable. The center conductor of the feeding line is directly connected to the second arm of the dipole. The antenna is therefore short-circuited for DC-signals.

No excessive force must be applied to the dipole arms, because they might bend or the soldered connections near the feedpoint may be damaged.

Additional EUT Data

Manufactured by	SPEAG
Manufactured on	July 26, 2001

DASY5 Validation Report for Head TSL

Date/Time: 07.02.2011 15:18:47

Test Laboratory: SPEAG, Zurich, Switzerland

DUT: Dipole 1900 MHz; Type: D1900V2; Serial: D1900V2 - SN:540

Communication System: CW; Frequency: 1900 MHz; Duty Cycle: 1:1

Medium: HSL U12 BB

Medium parameters used: $f = 1900$ MHz; $\sigma = 1.41$ mho/m; $\epsilon_r = 39.9$; $\rho = 1000$ kg/m³

Phantom section: Flat Section

Measurement Standard: DASY5 (IEEE/IEC/ANSI C63.19-2007)

DASY5 Configuration:

- Probe: ES3DV3 - SN3205; ConvF(5.09, 5.09, 5.09); Calibrated: 30.04.2010
- Sensor-Surface: 3mm (Mechanical Surface Detection)
- Electronics: DAE4 Sn601; Calibrated: 10.06.2010
- Phantom: Flat Phantom 5.0 (front); Type: QD000P50AA; Serial: 1001
- Measurement SW: DASY52, V52.6.1 Build (408)
- Postprocessing SW: SEMCAD X, V14.4.2 Build (2595)

Pin=250 mW /d=10mm, dist=3.0mm (ES-Probe)/Zoom Scan (7x7x7) /Cube 0: Measurement grid: dx=5mm, dy=5mm, dz=5mm

Reference Value = 96.936 V/m; Power Drift = 0.04 dB

Peak SAR (extrapolated) = 18.544 W/kg

SAR(1 g) = 10.1 mW/g; SAR(10 g) = 5.25 mW/g

Maximum value of SAR (measured) = 12.384 mW/g

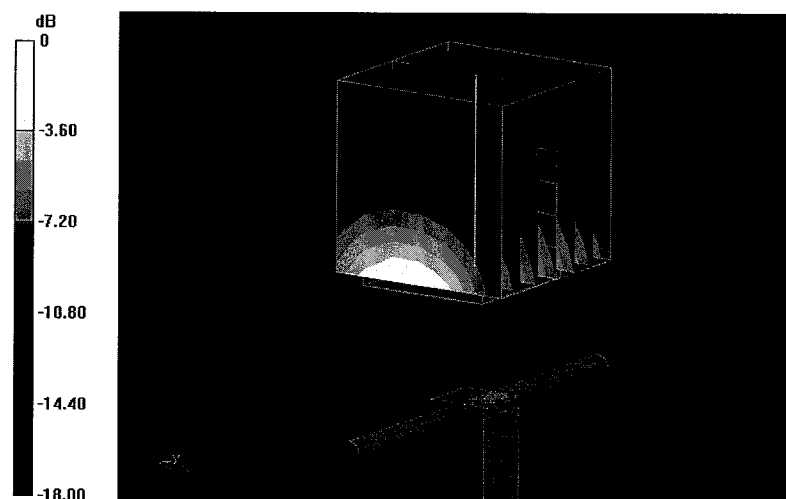

0 dB = 12.380mW/g

Impedance Measurement Plot for Head TSL

7 Feb 2011 16:45:39

CH1 S11 1 U FS 1: 50.525 Ω 4.1680 Ω 349.13 pF 1 900.000 000 MHz

*
Del
CA

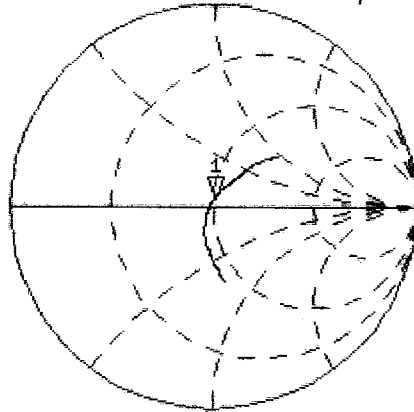

Avg
16
↑

CH2 S11 LOG 5 dB/REF -20 dB 1:-27.575 dB 1 900.000 000 MHz

CA

Avg
16
↑

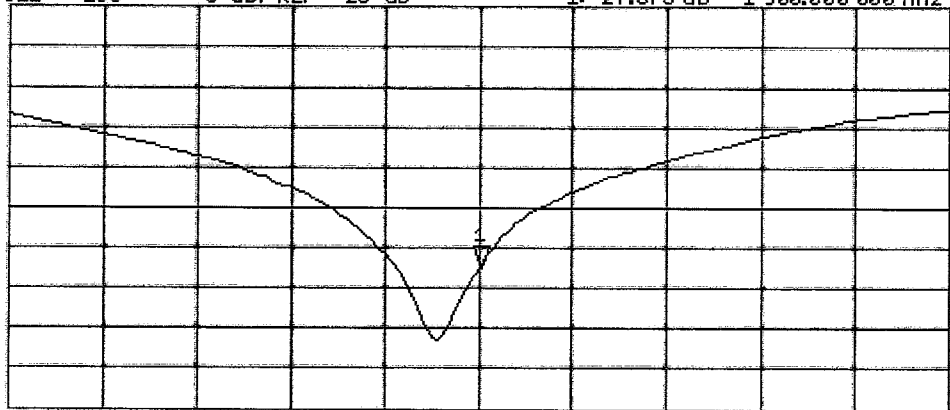

START 1 700.000 000 MHz

STOP 2 100.000 000 MHz

DASY5 Validation Report for Body TSL

Date/Time: 08.02.2011 12:04:35

Test Laboratory: SPEAG, Zurich, Switzerland

DUT: Dipole 1900 MHz; Type: D1900V2; Serial: D1900V2 - SN:540

Communication System: CW; Frequency: 1900 MHz; Duty Cycle: 1:1

Medium: MSL U12 BB

Medium parameters used: $f = 1900$ MHz; $\sigma = 1.55$ mho/m; $\epsilon_r = 52.9$; $\rho = 1000$ kg/m³

Phantom section: Flat Section

Measurement Standard: DASY5 (IEEE/IEC/ANSI C63.19-2007)

DASY5 Configuration:

- Probe: ES3DV3 - SN3205; ConvF(4.59, 4.59, 4.59); Calibrated: 30.04.2010
- Sensor-Surface: 3mm (Mechanical Surface Detection)
- Electronics: DAE4 Sn601; Calibrated: 10.06.2010
- Phantom: Flat Phantom 5.0 (back); Type: QD000P50AA; Serial: 1002
- Measurement SW: DASY52, V52.6.1 Build (408)
- Postprocessing SW: SEMCAD X, V14.4.2 Build (2595)

Pin=250 mW /d=10mm, dist=3.0mm (ES-Probe)/Zoom Scan (7x7x7) /Cube 0: Measurement grid: dx=5mm, dy=5mm, dz=5mm

Reference Value = 96.899 V/m; Power Drift = -0.03 dB

Peak SAR (extrapolated) = 17.597 W/kg

SAR(1 g) = 10.3 mW/g; SAR(10 g) = 5.43 mW/g

Maximum value of SAR (measured) = 13.038 mW/g

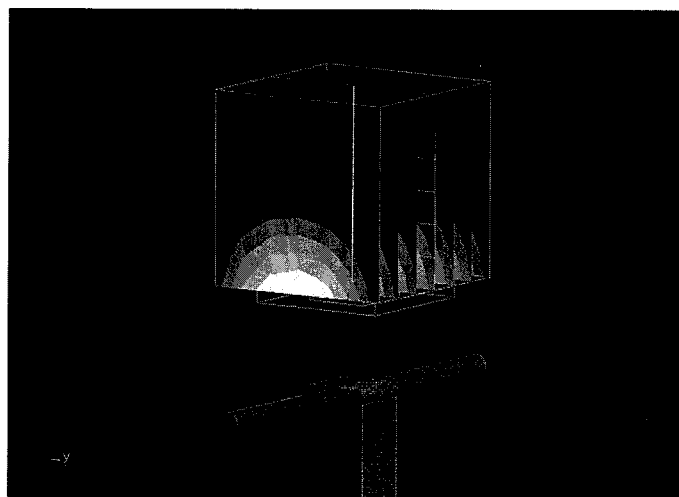
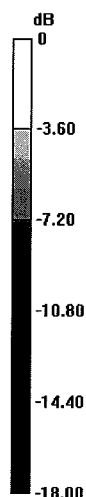

0 dB = 13.040mW/g

Impedance Measurement Plot for Body TSL

8 Feb 2011 10:45:02

CH1 S11 1 U FS 3: 45.568 Ω 5.0391 Ω 422.10 pF 1 900.000 000 MHz

*
De1
CA

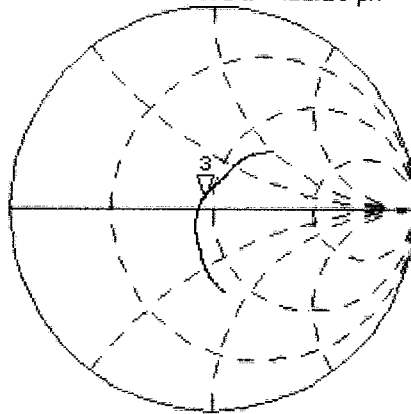

Avg
16

CH2 S11 LOG 5 dB/REF -20 dB 3:-23.090 dB 1 900.000 000 MHz

CA

Avg
16

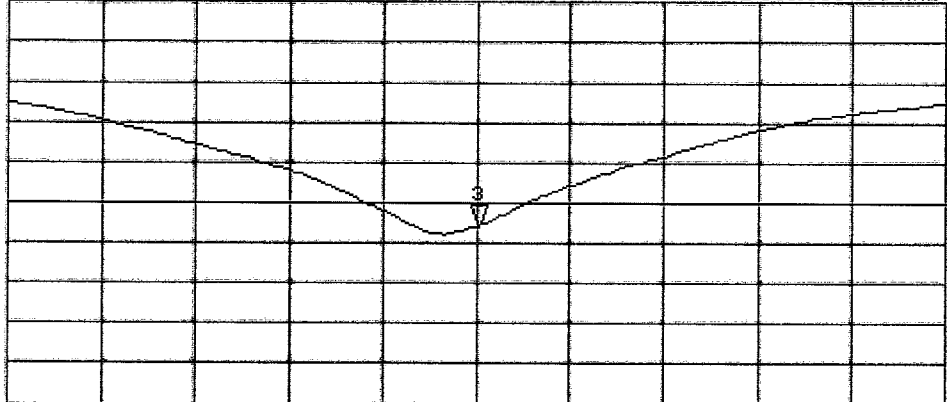

START 1 700.000 000 MHz

STOP 2 100.000 000 MHz

ASSET A1322 - Checked by *[Signature]*

21/02/2011

**Calibration Laboratory of
Schmid & Partner
Engineering AG**
Zeughausstrasse 43, 8004 Zurich, Switzerland



S Schweizerischer Kalibrierdienst
C Service suisse d'étalonnage
S Servizio svizzero di taratura
S Swiss Calibration Service

Accredited by the Swiss Accreditation Service (SAS)
The Swiss Accreditation Service is one of the signatories to the EA
Multilateral Agreement for the recognition of calibration certificates

Accreditation No.: **SCS 108**

Client **RFI**

Certificate No: **D2450V2-725_Feb11**

CALIBRATION CERTIFICATE

Object **D2450V2 - SN: 725**

Calibration procedure(s) **QA CAL-05.v8
Calibration procedure for dipole validation kits**

Calibration date: **February 08, 2011**

This calibration certificate documents the traceability to national standards, which realize the physical units of measurements (SI).
The measurements and the uncertainties with confidence probability are given on the following pages and are part of the certificate.

All calibrations have been conducted in the closed laboratory facility: environment temperature (22 ± 3)°C and humidity < 70%.

Calibration Equipment used (M&TE critical for calibration)

Primary Standards	ID #	Cal Date (Certificate No.)	Scheduled Calibration
Power meter EPM-442A	GB37480704	06-Oct-10 (No. 217-01266)	Oct-11
Power sensor HP 8481A	US37292783	06-Oct-10 (No. 217-01266)	Oct-11
Reference 20 dB Attenuator	SN: 5086 (20g)	30-Mar-10 (No. 217-01158)	Mar-11
Type-N mismatch combination	SN: 5047.2 / 06327	30-Mar-10 (No. 217-01162)	Mar-11
Reference Probe ES3DV3	SN: 3205	30-Apr-10 (No. ES3-3205_Apr10)	Apr-11
DAE4	SN: 601	10-Jun-10 (No. DAE4-601_Jun10)	Jun-11

Secondary Standards	ID #	Check Date (in house)	Scheduled Check
Power sensor HP 8481A	MY41092317	18-Oct-02 (in house check Oct-09)	In house check: Oct-11
RF generator R&S SMT-06	100005	4-Aug-99 (in house check Oct-09)	In house check: Oct-11
Network Analyzer HP 8753E	US37390585 S4206	18-Oct-01 (in house check Oct-10)	In house check: Oct-11

	Name	Function	Signature
Calibrated by:	Dimce Iliev	Laboratory Technician	<i>[Signature]</i>
Approved by:	Katja Pokovic	Technical Manager	<i>[Signature]</i>

Issued: February 8, 2011

This calibration certificate shall not be reproduced except in full without written approval of the laboratory.



Accredited by the Swiss Accreditation Service (SAS)
The Swiss Accreditation Service is one of the signatories to the EA
Multilateral Agreement for the recognition of calibration certificates

Accreditation No.: **SCS 108**

Glossary:

TSL	tissue simulating liquid
ConvF	sensitivity in TSL / NORM x,y,z
N/A	not applicable or not measured

Calibration is Performed According to the Following Standards:

- IEEE Std 1528-2003, "IEEE Recommended Practice for Determining the Peak Spatial-Averaged Specific Absorption Rate (SAR) in the Human Head from Wireless Communications Devices: Measurement Techniques", December 2003
- IEC 62209-1, "Procedure to measure the Specific Absorption Rate (SAR) for hand-held devices used in close proximity to the ear (frequency range of 300 MHz to 3 GHz)", February 2005
- Federal Communications Commission Office of Engineering & Technology (FCC OET), "Evaluating Compliance with FCC Guidelines for Human Exposure to Radiofrequency Electromagnetic Fields; Additional Information for Evaluating Compliance of Mobile and Portable Devices with FCC Limits for Human Exposure to Radiofrequency Emissions", Supplement C (Edition 01-01) to Bulletin 65

Additional Documentation:

- DASY4/5 System Handbook

Methods Applied and Interpretation of Parameters:

- Measurement Conditions:** Further details are available from the Validation Report at the end of the certificate. All figures stated in the certificate are valid at the frequency indicated.
- Antenna Parameters with TSL:** The dipole is mounted with the spacer to position its feed point exactly below the center marking of the flat phantom section, with the arms oriented parallel to the body axis.
- Feed Point Impedance and Return Loss:** These parameters are measured with the dipole positioned under the liquid filled phantom. The impedance stated is transformed from the measurement at the SMA connector to the feed point. The Return Loss ensures low reflected power. No uncertainty required.
- Electrical Delay:** One-way delay between the SMA connector and the antenna feed point. No uncertainty required.
- SAR measured:** SAR measured at the stated antenna input power.
- SAR normalized:** SAR as measured, normalized to an input power of 1 W at the antenna connector.
- SAR for nominal TSL parameters:** The measured TSL parameters are used to calculate the nominal SAR result.

Measurement Conditions

DASY system configuration, as far as not given on page 1.

DASY Version	DASY5	V52.6
Extrapolation	Advanced Extrapolation	
Phantom	Modular Flat Phantom V5.0	
Distance Dipole Center - TSL	10 mm	with Spacer
Zoom Scan Resolution	dx, dy, dz = 5 mm	
Frequency	2450 MHz \pm 1 MHz	

Head TSL parameters

The following parameters and calculations were applied.

	Temperature	Permittivity	Conductivity
Nominal Head TSL parameters	22.0 °C	39.2	1.80 mho/m
Measured Head TSL parameters	(22.0 \pm 0.2) °C	39.1 \pm 6 %	1.73 mho/m \pm 6 %
Head TSL temperature during test	(21.0 \pm 0.2) °C	----	----

SAR result with Head TSL

SAR averaged over 1 cm³ (1 g) of Head TSL	Condition	
SAR measured	250 mW input power	13.0 mW / g
SAR normalized	normalized to 1W	52.0 mW / g
SAR for nominal Head TSL parameters	normalized to 1W	52.9 mW /g \pm 17.0 % (k=2)

SAR averaged over 10 cm³ (10 g) of Head TSL	condition	
SAR measured	250 mW input power	6.13 mW / g
SAR normalized	normalized to 1W	24.5 mW / g
SAR for nominal Head TSL parameters	normalized to 1W	24.7 mW /g \pm 16.5 % (k=2)

Body TSL parameters

The following parameters and calculations were applied.

	Temperature	Permittivity	Conductivity
Nominal Body TSL parameters	22.0 °C	52.7	1.95 mho/m
Measured Body TSL parameters	(22.0 ± 0.2) °C	52.2 ± 6 %	1.94 mho/m ± 6 %
Body TSL temperature during test	(21.0 ± 0.2) °C	----	----

SAR result with Body TSL

SAR averaged over 1 cm ³ (1 g) of Body TSL	Condition	
SAR measured	250 mW input power	13.0 mW / g
SAR normalized	normalized to 1W	52.0 mW / g
SAR for nominal Body TSL parameters	normalized to 1W	51.9 mW / g ± 17.0 % (k=2)

SAR averaged over 10 cm ³ (10 g) of Body TSL	condition	
SAR measured	250 mW input power	6.04 mW / g
SAR normalized	normalized to 1W	24.2 mW / g
SAR for nominal Body TSL parameters	normalized to 1W	24.1 mW / g ± 16.5 % (k=2)

Appendix

Antenna Parameters with Head TSL

Impedance, transformed to feed point	45.6 Ω + 7.9 j Ω
Return Loss	- 20.5 dB

Antenna Parameters with Body TSL

Impedance, transformed to feed point	49.5 Ω + 9.7 j Ω
Return Loss	- 20.2 dB

General Antenna Parameters and Design

Electrical Delay (one direction)	1.152 ns
----------------------------------	----------

After long term use with 100W radiated power, only a slight warming of the dipole near the feedpoint can be measured.

The dipole is made of standard semirigid coaxial cable. The center conductor of the feeding line is directly connected to the second arm of the dipole. The antenna is therefore short-circuited for DC-signals.

No excessive force must be applied to the dipole arms, because they might bend or the soldered connections near the feedpoint may be damaged.

Additional EUT Data

Manufactured by	SPEAG
Manufactured on	October 16, 2002

DASY5 Validation Report for Head TSL

Date/Time: 07.02.2011 14:34:55

Test Laboratory: SPEAG, Zurich, Switzerland

DUT: Dipole 2450 MHz; Type: D2450V2; Serial: D2450V2 - SN:725

Communication System: CW; Frequency: 2450 MHz; Duty Cycle: 1:1

Medium: HSL U12 BB

Medium parameters used: $f = 2450$ MHz; $\sigma = 1.74$ mho/m; $\epsilon_r = 39.3$; $\rho = 1000$ kg/m³

Phantom section: Flat Section

Measurement Standard: DASY5 (IEEE/IEC/ANSI C63.19-2007)

DASY5 Configuration:

- Probe: ES3DV3 - SN3205; ConvF(4.53, 4.53, 4.53); Calibrated: 30.04.2010
- Sensor-Surface: 3mm (Mechanical Surface Detection)
- Electronics: DAE4 Sn601; Calibrated: 10.06.2010
- Phantom: Flat Phantom 5.0 (front); Type: QD000P50AA; Serial: 1001
- Measurement SW: DASY52, V52.6.1 Build (408)
- Postprocessing SW: SEMCAD X, V14.4.2 Build (2595)

Pin=250 mW /d=10mm, dist=3.0mm (ES-Probe)/Zoom Scan (7x7x7) /Cube 0: Measurement grid: dx=5mm, dy=5mm, dz=5mm

Reference Value = 101.3 V/m; Power Drift = 0.05 dB

Peak SAR (extrapolated) = 26.701 W/kg

SAR(1 g) = 13 mW/g; SAR(10 g) = 6.13 mW/g

Maximum value of SAR (measured) = 16.608 mW/g

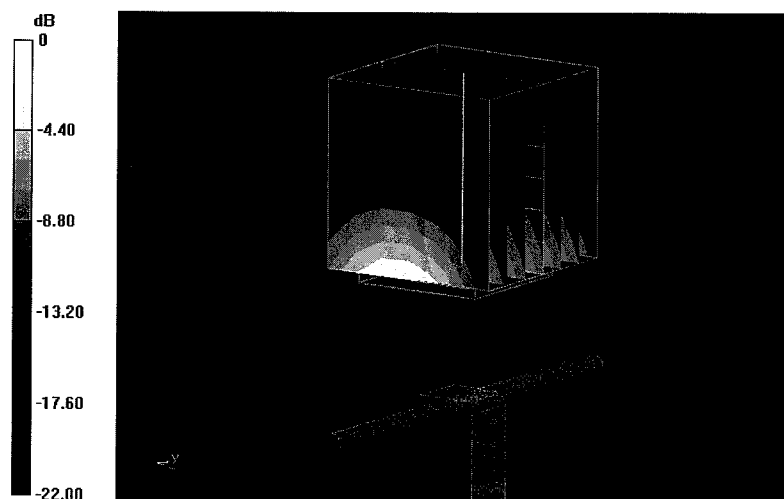

0 dB = 16.610mW/g

Impedance Measurement Plot for Head TSL

7 Feb 2011 16:48:44

CH1 S11 1 U FS 2: 45.582 Ω 7.8730 Ω 511.44 μ H 2 450.000 000 MHz

*
De1
CA

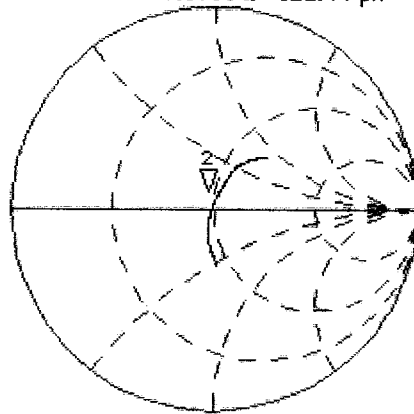

Avg
16

↑

CH2 S11 LOG 5 dB/REF -20 dB 2:-20.528 dB 2 450.000 000 MHz

CA

Avg
16

↑

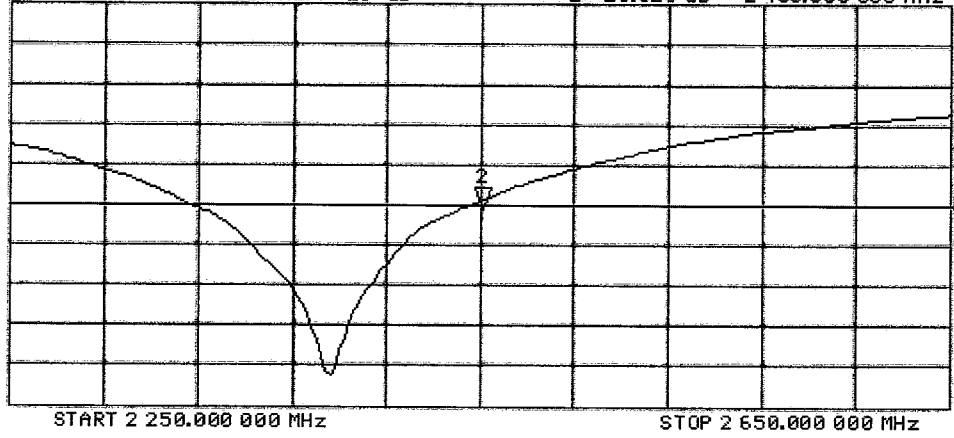

DASY5 Validation Report for Body TSL

Date/Time: 08.02.2011 12:48:13

Test Laboratory: SPEAG, Zurich, Switzerland

DUT: Dipole 2450 MHz; Type: D2450V2; Serial: D2450V2 - SN:725

Communication System: CW; Frequency: 2450 MHz; Duty Cycle: 1:1

Medium: MSL U12 BB

Medium parameters used: $f = 2450$ MHz; $\sigma = 1.95$ mho/m; $\epsilon_r = 52.4$; $\rho = 1000$ kg/m³

Phantom section: Flat Section

Measurement Standard: DASY5 (IEEE/IEC/ANSI C63.19-2007)

DASY5 Configuration:

- Probe: ES3DV3 - SN3205; ConvF(4.31, 4.31, 4.31); Calibrated: 30.04.2010
- Sensor-Surface: 3mm (Mechanical Surface Detection)
- Electronics: DAE4 Sn601; Calibrated: 10.06.2010
- Phantom: Flat Phantom 5.0 (back); Type: QD000P50AA; Serial: 1002
- Measurement SW: DASY52, V52.6.1 Build (408)
- Postprocessing SW: SEMCAD X, V14.4.2 Build (2595)

Pin=250 mW /d=10mm, dist=3.0mm (ES-Probe)/Zoom Scan (7x7x7) /Cube 0: Measurement grid: dx=5mm, dy=5mm, dz=5mm

Reference Value = 96.406 V/m; Power Drift = -0.08 dB

Peak SAR (extrapolated) = 27.401 W/kg

SAR(1 g) = 13 mW/g; SAR(10 g) = 6.04 mW/g

Maximum value of SAR (measured) = 17.121 mW/g

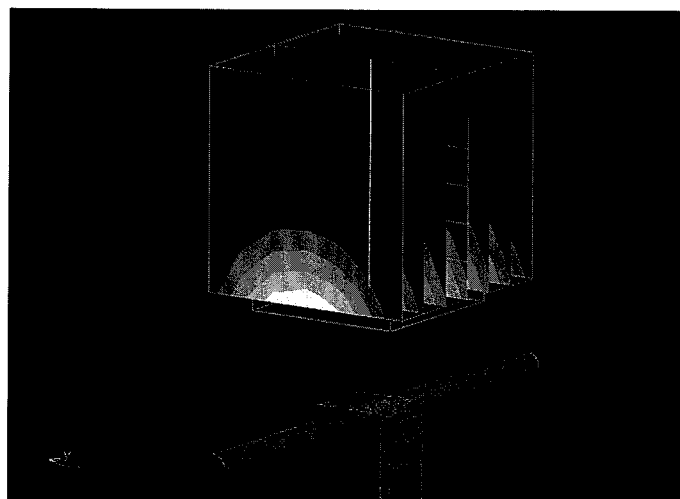

0 dB = 17.120mW/g

Impedance Measurement Plot for Body TSL

8 Feb 2011 10:56:06

[CH1] S11 1 U FS 5: 49.523 Ω 9.7422 Ω 632.86 μ H 2 450.000 000 MHz

*
De1
CA

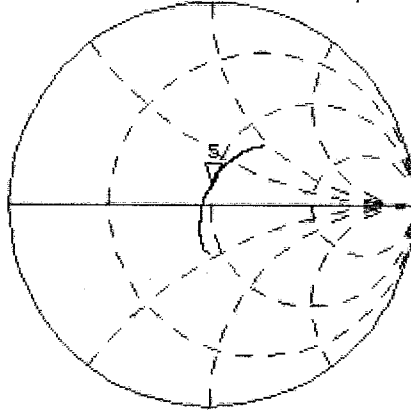

Avg
16

↑

CH2 S11 LOG 5 dB/REF -20 dB 5: -20.215 dB 2 450.000 000 MHz

CA

Avg
16

↑

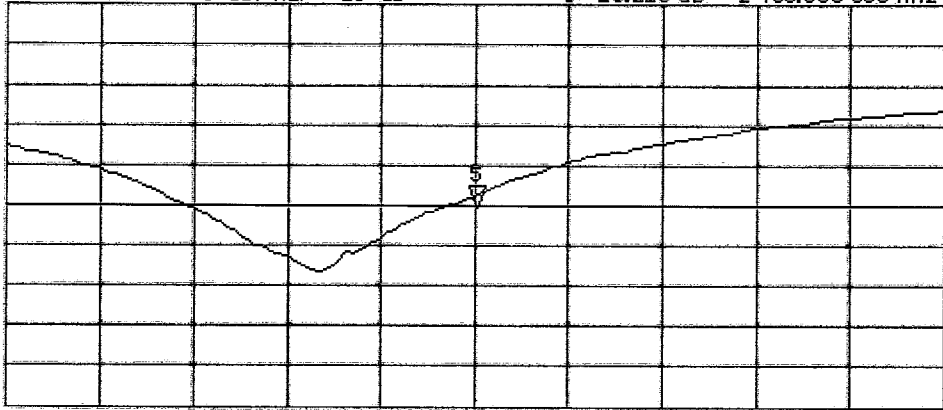

START 2 250.000 000 MHz

STOP 2 650.000 000 MHz

Checked by *AD* 31-july - 2011
RFI Asset A1185

**Calibration Laboratory of
Schmid & Partner
Engineering AG**
Zeughausstrasse 43, 8004 Zurich, Switzerland



S Schweizerischer Kalibrierdienst
C Service suisse d'étalonnage
S Servizio svizzero di taratura
Swiss Calibration Service

Accredited by the Swiss Accreditation Service (SAS)
The Swiss Accreditation Service is one of the signatories to the EA
Multilateral Agreement for the recognition of calibration certificates

Accreditation No.: **SCS 108**

Client **RFI**

Certificate No: **ET3-1528_Jul11**

CALIBRATION CERTIFICATE

Object **ET3DV6 - SN:1528**

Calibration procedure(s) **QA CAL-01.v8, QA CAL-12.v7, QA CAL-23.v4, QA CAL-25.v4
Calibration procedure for dosimetric E-field probes**

Calibration date: **July 18, 2011**

This calibration certificate documents the traceability to national standards, which realize the physical units of measurements (SI).
The measurements and the uncertainties with confidence probability are given on the following pages and are part of the certificate.

All calibrations have been conducted in the closed laboratory facility: environment temperature (22 ± 3)°C and humidity < 70%.

Calibration Equipment used (M&TE critical for calibration)

Primary Standards	ID	Cal Date (Certificate No.)	Scheduled Calibration
Power meter E4419B	GB41293874	31-Mar-11 (No. 217-01372)	Apr-12
Power sensor E4412A	MY41498087	31-Mar-11 (No. 217-01372)	Apr-12
Reference 3 dB Attenuator	SN: S5054 (3c)	29-Mar-11 (No. 217-01369)	Apr-12
Reference 20 dB Attenuator	SN: S5086 (20b)	29-Mar-11 (No. 217-01367)	Apr-12
Reference 30 dB Attenuator	SN: S5129 (30b)	29-Mar-11 (No. 217-01370)	Apr-12
Reference Probe ES3DV2	SN: 3013	29-Dec-10 (No. ES3-3013_Dec10)	Dec-11
DAE4	SN: 654	3-May-11 (No. DAE4-654_May11)	May-12
Secondary Standards	ID	Check Date (in house)	Scheduled Check
RF generator HP 8648C	US3642U01700	4-Aug-99 (in house check Oct-09)	In house check: Oct-11
Network Analyzer HP 8753E	US37390585	18-Oct-01 (in house check Oct-10)	In house check: Oct-11

	Name	Function	Signature
Calibrated by:	Jeton Kastrati	Laboratory Technician	<i>[Signature]</i>
Approved by:	Katja Pokovic	Technical Manager	<i>[Signature]</i>

Issued: July 20, 2011

This calibration certificate shall not be reproduced except in full without written approval of the laboratory.



Accredited by the Swiss Accreditation Service (SAS)

Accreditation No.: **SCS 108**

The Swiss Accreditation Service is one of the signatories to the EA
Multilateral Agreement for the recognition of calibration certificates

Glossary:

TSL	tissue simulating liquid
NORM _{x,y,z}	sensitivity in free space
ConvF	sensitivity in TSL / NORM _{x,y,z}
DCP	diode compression point
CF	crest factor (1/duty_cycle) of the RF signal
A, B, C	modulation dependent linearization parameters
Polarization ϕ	ϕ rotation around probe axis
Polarization ϑ	ϑ rotation around an axis that is in the plane normal to probe axis (at measurement center), i.e., $\vartheta = 0$ is normal to probe axis

Calibration is Performed According to the Following Standards:

- IEEE Std 1528-2003, "IEEE Recommended Practice for Determining the Peak Spatial-Averaged Specific Absorption Rate (SAR) in the Human Head from Wireless Communications Devices: Measurement Techniques", December 2003
- IEC 62209-1, "Procedure to measure the Specific Absorption Rate (SAR) for hand-held devices used in close proximity to the ear (frequency range of 300 MHz to 3 GHz)", February 2005

Methods Applied and Interpretation of Parameters:

- NORM_{x,y,z}**: Assessed for E-field polarization $\vartheta = 0$ ($f \leq 900$ MHz in TEM-cell; $f > 1800$ MHz: R22 waveguide). NORM_{x,y,z} are only intermediate values, i.e., the uncertainties of NORM_{x,y,z} does not affect the E²-field uncertainty inside TSL (see below ConvF).
- NORM(f)_{x,y,z}** = NORM_{x,y,z} * frequency_response (see Frequency Response Chart). This linearization is implemented in DASY4 software versions later than 4.2. The uncertainty of the frequency response is included in the stated uncertainty of ConvF.
- DCP_{x,y,z}**: DCP are numerical linearization parameters assessed based on the data of power sweep with CW signal (no uncertainty required). DCP does not depend on frequency nor media.
- PAR**: PAR is the Peak to Average Ratio that is not calibrated but determined based on the signal characteristics
- A_{x,y,z}; B_{x,y,z}; C_{x,y,z}; VR_{x,y,z}**: A, B, C are numerical linearization parameters assessed based on the data of power sweep for specific modulation signal. The parameters do not depend on frequency nor media. VR is the maximum calibration range expressed in RMS voltage across the diode.
- ConvF and Boundary Effect Parameters**: Assessed in flat phantom using E-field (or Temperature Transfer Standard for $f \leq 800$ MHz) and inside waveguide using analytical field distributions based on power measurements for $f > 800$ MHz. The same setups are used for assessment of the parameters applied for boundary compensation (alpha, depth) of which typical uncertainty values are given. These parameters are used in DASY4 software to improve probe accuracy close to the boundary. The sensitivity in TSL corresponds to NORM_{x,y,z} * ConvF whereby the uncertainty corresponds to that given for ConvF. A frequency dependent ConvF is used in DASY version 4.4 and higher which allows extending the validity from ± 50 MHz to ± 100 MHz.
- Spherical isotropy (3D deviation from isotropy)**: in a field of low gradients realized using a flat phantom exposed by a patch antenna.
- Sensor Offset**: The sensor offset corresponds to the offset of virtual measurement center from the probe tip (on probe axis). No tolerance required.

Probe ET3DV6

SN:1528

Manufactured: March 21, 2000
Calibrated: July 18, 2011

Calibrated for DASY/EASY Systems
(Note: non-compatible with DASY2 system!)

DASY/EASY - Parameters of Probe: ET3DV6 - SN:1528

Basic Calibration Parameters

	Sensor X	Sensor Y	Sensor Z	Unc (k=2)
Norm ($\mu\text{V}/(\text{V}/\text{m})^2$) ^A	1.46	1.87	1.62	± 10.1 %
DCP (mV) ^B	99.5	97.2	99.6	

Modulation Calibration Parameters

UID	Communication System Name	PAR		A dB	B dB	C dB	VR mV	Unc ^E (k=2)
10000	CW	0.00	X	0.00	0.00	1.00	132.2	±2.2 %
			Y	0.00	0.00	1.00	106.9	
			Z	0.00	0.00	1.00	128.6	

The reported uncertainty of measurement is stated as the standard uncertainty of measurement multiplied by the coverage factor k=2, which for a normal distribution corresponds to a coverage probability of approximately 95%.

^A The uncertainties of NormX,Y,Z do not affect the E²-field uncertainty inside TSL (see Pages 5 and 6).

^B Numerical linearization parameter: uncertainty not required.

^E Uncertainty is determined using the max. deviation from linear response applying rectangular distribution and is expressed for the square of the field value.

DASY/EASY - Parameters of Probe: ET3DV6 - SN:1528

Calibration Parameter Determined in Head Tissue Simulating Media

f (MHz) ^C	Relative Permittivity ^F	Conductivity (S/m) ^F	ConvF X	ConvF Y	ConvF Z	Alpha	Depth (mm)	Unct. (k=2)
450	45.3	0.87	7.28	7.28	7.28	0.20	2.22	± 13.4 %
750	41.9	0.89	6.26	6.26	6.26	0.97	1.69	± 12.0 %
900	41.5	0.97	5.85	5.85	5.85	0.97	1.65	± 12.0 %
1750	40.1	1.37	5.03	5.03	5.03	0.57	2.17	± 12.0 %
1900	40.0	1.40	4.81	4.81	4.81	0.68	2.03	± 12.0 %

^C Frequency validity of ± 100 MHz only applies for DASY v4.4 and higher (see Page 2), else it is restricted to ± 50 MHz. The uncertainty is the RSS of the ConvF uncertainty at calibration frequency and the uncertainty for the indicated frequency band.

^F At frequencies below 3 GHz, the validity of tissue parameters (ϵ and σ) can be relaxed to ± 10% if liquid compensation formula is applied to measured SAR values. At frequencies above 3 GHz, the validity of tissue parameters (ϵ and σ) is restricted to ± 5%. The uncertainty is the RSS of the ConvF uncertainty for indicated target tissue parameters.

DASY/EASY - Parameters of Probe: ET3DV6- SN:1528

Calibration Parameter Determined in Body Tissue Simulating Media

f (MHz) ^C	Relative Permittivity ^F	Conductivity (S/m) ^F	ConvF X	ConvF Y	ConvF Z	Alpha	Depth (mm)	Unct. (k=2)
450	56.7	0.94	7.66	7.66	7.66	0.15	2.23	± 13.4 %
750	55.5	0.96	5.98	5.98	5.98	1.00	1.67	± 12.0 %
900	55.0	1.05	5.77	5.77	5.77	1.00	1.66	± 12.0 %
1750	53.4	1.49	4.57	4.57	4.57	0.68	2.55	± 12.0 %
1900	53.3	1.52	4.37	4.37	4.37	0.72	2.41	± 12.0 %

^C Frequency validity of ± 100 MHz only applies for DASY v4.4 and higher (see Page 2), else it is restricted to ± 50 MHz. The uncertainty is the RSS of the ConvF uncertainty at calibration frequency and the uncertainty for the indicated frequency band.

^F At frequencies below 3 GHz, the validity of tissue parameters (ϵ and σ) can be relaxed to ± 10% if liquid compensation formula is applied to measured SAR values. At frequencies above 3 GHz, the validity of tissue parameters (ϵ and σ) is restricted to ± 5%. The uncertainty is the RSS of the ConvF uncertainty for indicated target tissue parameters.

Frequency Response of E-Field (TEM-Cell:ifi110 EXX, Waveguide: R22)

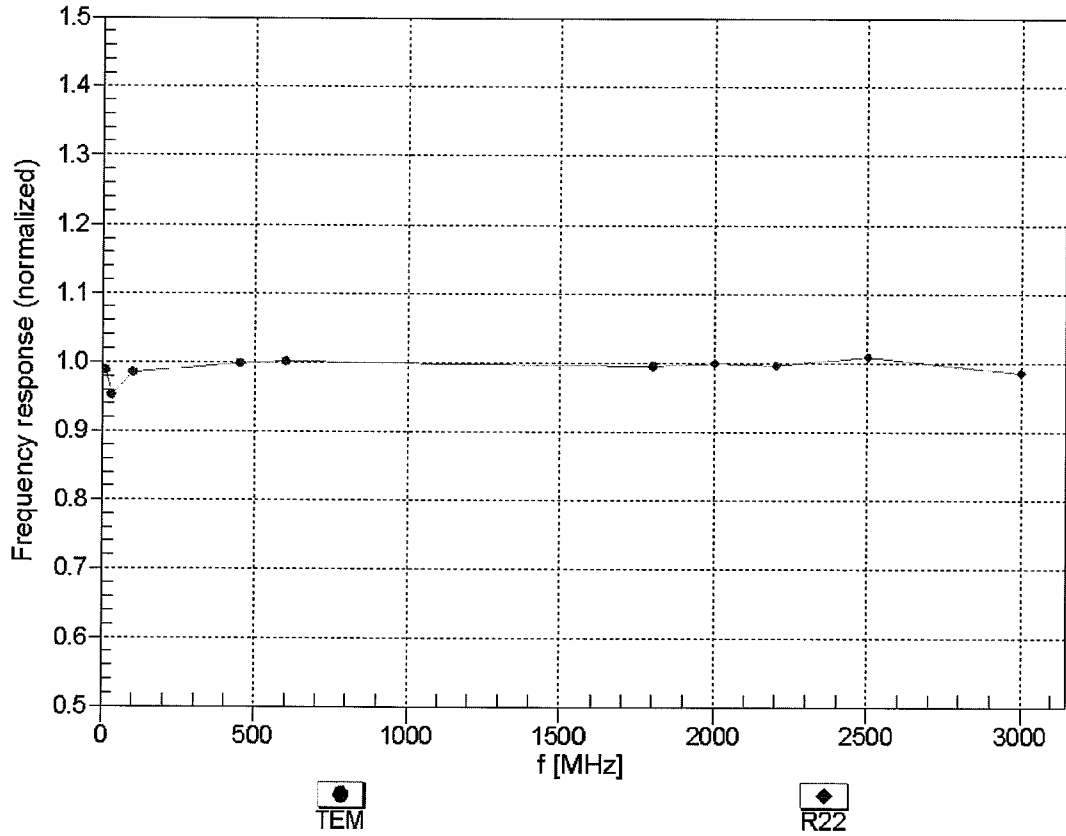

Uncertainty of Frequency Response of E-field: $\pm 6.3\%$ (k=2)

Receiving Pattern (ϕ), $\theta = 0^\circ$

f=600 MHz, TEM

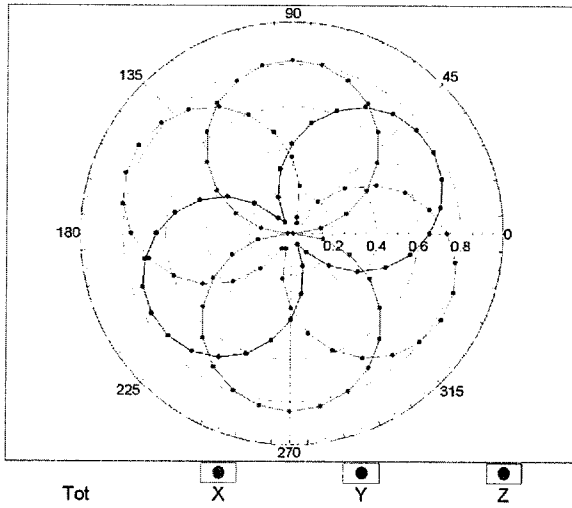

f=1800 MHz, R22

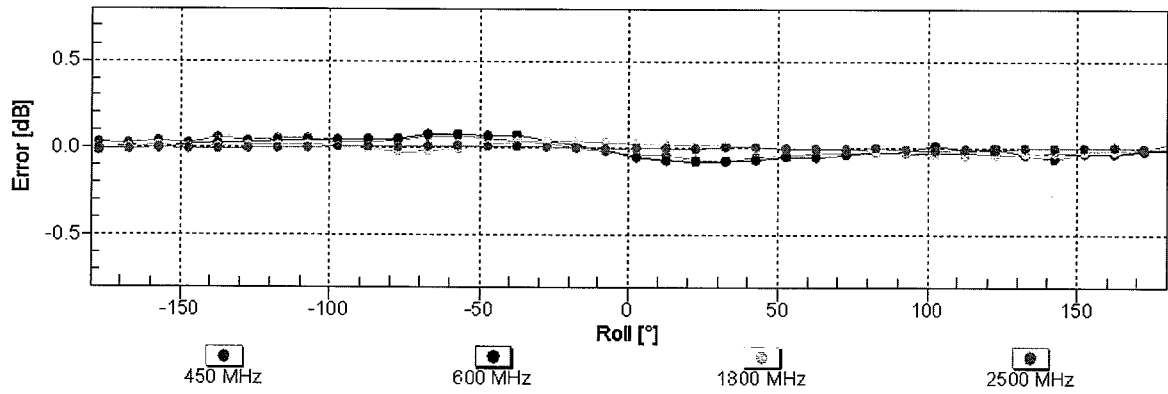
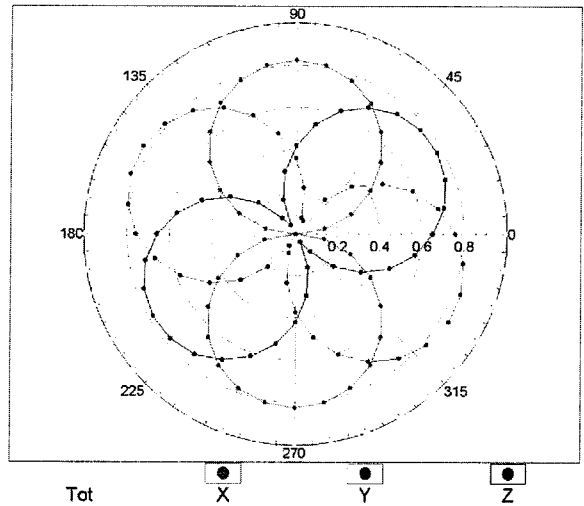

Uncertainty of Axial Isotropy Assessment: $\pm 0.5\%$ ($k=2$)

Dynamic Range f(SAR_{head}) (TEM cell , f = 900 MHz)

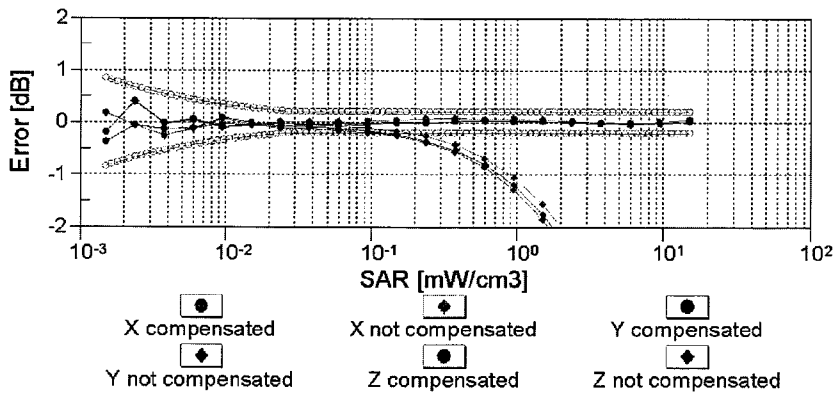
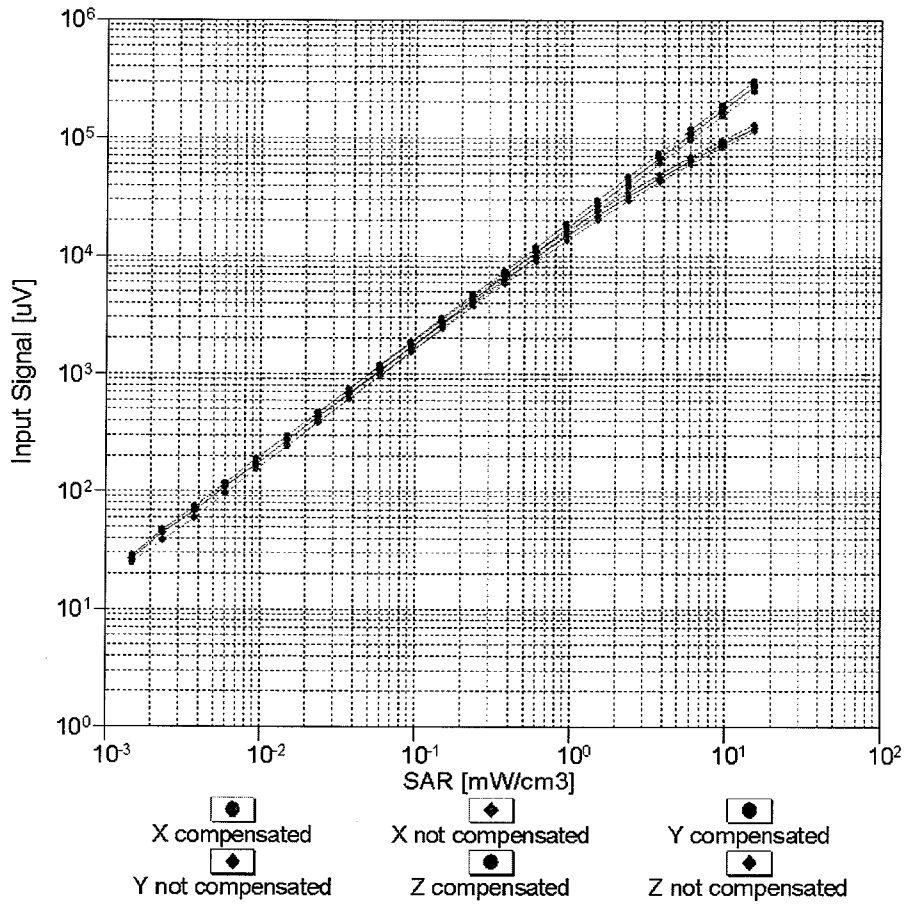

Uncertainty of Linearity Assessment: ± 0.6% (k=2)

Conversion Factor Assessment

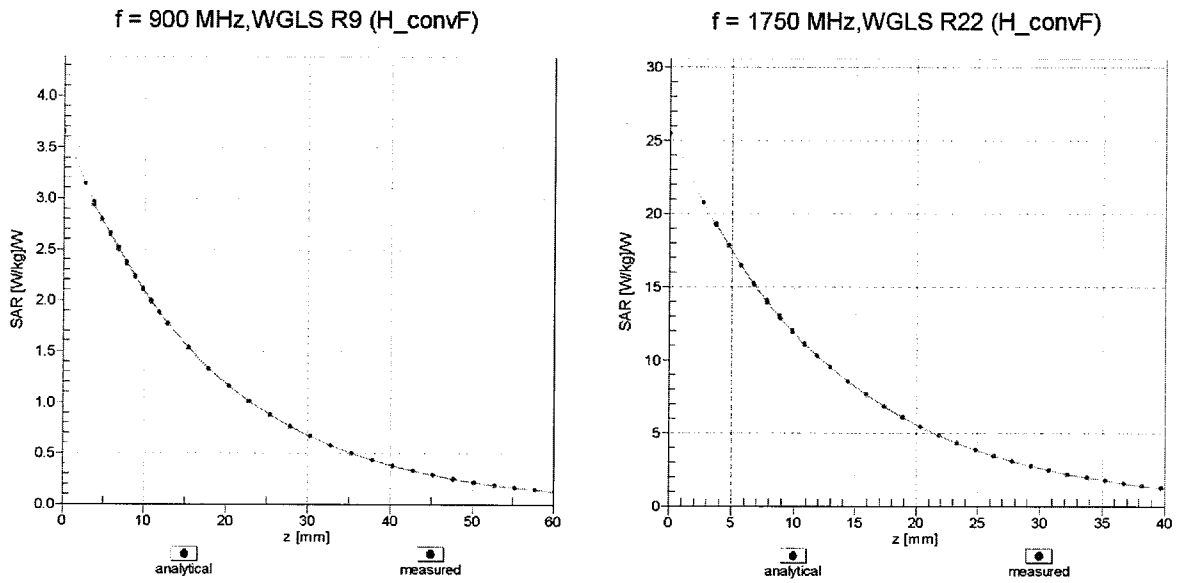

Deviation from Isotropy in Liquid Error (ϕ, θ), f = 900 MHz

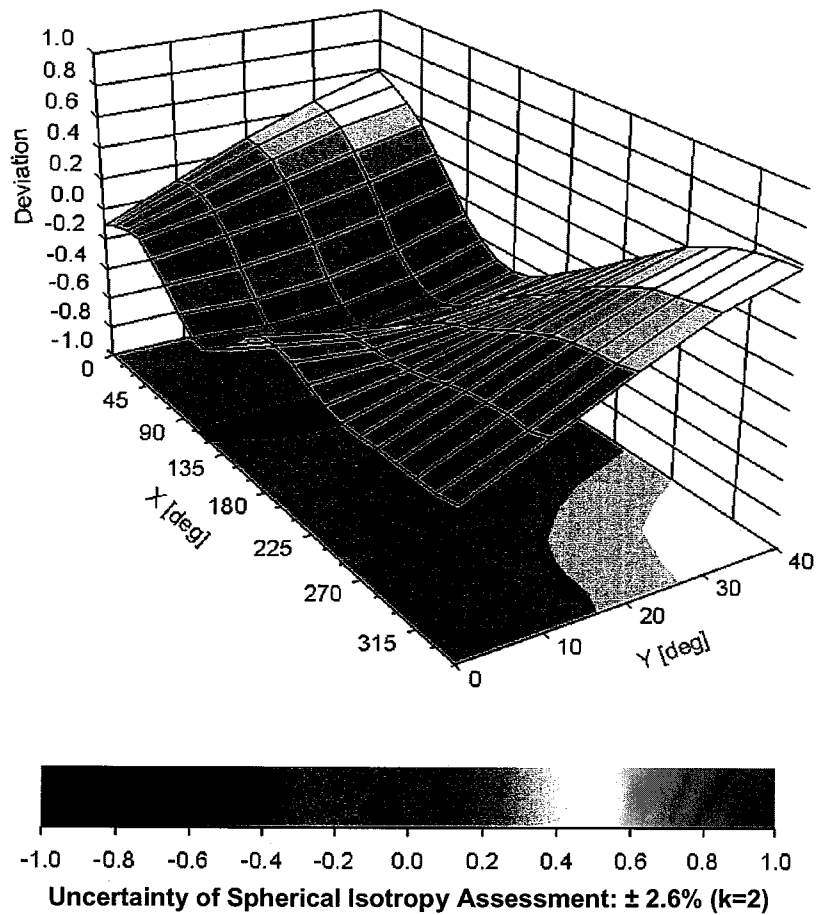

DASY/EASY - Parameters of Probe: ET3DV6 - SN:1528**Other Probe Parameters**

Sensor Arrangement	Triangular
Connector Angle (°)	Not applicable
Mechanical Surface Detection Mode	enabled
Optical Surface Detection Mode	enabled
Probe Overall Length	337 mm
Probe Body Diameter	10 mm
Tip Length	10 mm
Tip Diameter	6.8 mm
Probe Tip to Sensor X Calibration Point	2.7 mm
Probe Tip to Sensor Y Calibration Point	2.7 mm
Probe Tip to Sensor Z Calibration Point	2.7 mm
Recommended Measurement Distance from Surface	4 mm

27-SEPT-2011
Checked by R. Junt

Calibration Laboratory of
Schmid & Partner
Engineering AG
Zeughausstrasse 43, 8004 Zurich, Switzerland



S Schweizerischer Kalibrierdienst
C Service suisse d'étalonnage
S Servizio svizzero di taratura
S Swiss Calibration Service

Accredited by the Swiss Accreditation Service (SAS)
The Swiss Accreditation Service is one of the signatories to the EA
Multilateral Agreement for the recognition of calibration certificates

Accreditation No.: **SCS 108**

Client **RFI**

Certificate No: **EX3-3814_Sep11**

CALIBRATION CERTIFICATE

Object **EX3DV4 - SN:3814**

Calibration procedure(s) **QA CAL-01.v8, QA CAL-12.v7, QA CAL-14.v3, QA CAL-23.v4, QA CAL-25.v4
Calibration procedure for dosimetric E-field probes**

Calibration date: **September 22, 2011**

This calibration certificate documents the traceability to national standards, which realize the physical units of measurements (SI).
The measurements and the uncertainties with confidence probability are given on the following pages and are part of the certificate.

All calibrations have been conducted in the closed laboratory facility: environment temperature (22 ± 3)°C and humidity < 70%.

Calibration Equipment used (M&TE critical for calibration)

Primary Standards	ID	Cal Date (Certificate No.)	Scheduled Calibration
Power meter E4419B	GB41293874	31-Mar-11 (No. 217-01372)	Apr-12
Power sensor E4412A	MY41498087	31-Mar-11 (No. 217-01372)	Apr-12
Reference 3 dB Attenuator	SN: S5054 (3c)	29-Mar-11 (No. 217-01369)	Apr-12
Reference 20 dB Attenuator	SN: S5086 (20b)	29-Mar-11 (No. 217-01367)	Apr-12
Reference 30 dB Attenuator	SN: S5129 (30b)	29-Mar-11 (No. 217-01370)	Apr-12
Reference Probe ES3DV2	SN: 3013	29-Dec-10 (No. ES3-3013_Dec10)	Dec-11
DAE4	SN: 654	3-May-11 (No. DAE4-654_May11)	May-12
Secondary Standards	ID	Check Date (in house)	Scheduled Check
RF generator HP 8648C	US3642U01700	4-Aug-99 (in house check Oct-09)	In house check: Oct-11
Network Analyzer HP 8753E	US37390585	18-Oct-01 (in house check Oct-10)	In house check: Oct-11

	Name	Function	Signature
Calibrated by:	Katja Pokovic	Technical Manager	
Approved by:	Fin Bornholt	R&D Director	

Issued: September 22, 2011

This calibration certificate shall not be reproduced except in full without written approval of the laboratory.



Accredited by the Swiss Accreditation Service (SAS)

Accreditation No.: **SCS 108**

The Swiss Accreditation Service is one of the signatories to the EA
Multilateral Agreement for the recognition of calibration certificates

Glossary:

TSL	tissue simulating liquid
NORM _{x,y,z}	sensitivity in free space
ConvF	sensitivity in TSL / NORM _{x,y,z}
DCP	diode compression point
CF	crest factor (1/duty_cycle) of the RF signal
A, B, C	modulation dependent linearization parameters
Polarization φ	φ rotation around probe axis
Polarization ϑ	ϑ rotation around an axis that is in the plane normal to probe axis (at measurement center), i.e., $\vartheta = 0$ is normal to probe axis

Calibration is Performed According to the Following Standards:

- IEEE Std 1528-2003, "IEEE Recommended Practice for Determining the Peak Spatial-Averaged Specific Absorption Rate (SAR) in the Human Head from Wireless Communications Devices: Measurement Techniques", December 2003
- IEC 62209-1, "Procedure to measure the Specific Absorption Rate (SAR) for hand-held devices used in close proximity to the ear (frequency range of 300 MHz to 3 GHz)", February 2005

Methods Applied and Interpretation of Parameters:

- NORM_{x,y,z}**: Assessed for E-field polarization $\vartheta = 0$ ($f \leq 900$ MHz in TEM-cell; $f > 1800$ MHz: R22 waveguide). NORM_{x,y,z} are only intermediate values, i.e., the uncertainties of NORM_{x,y,z} does not affect the E²-field uncertainty inside TSL (see below ConvF).
- NORM(f)_{x,y,z}** = NORM_{x,y,z} * frequency_response (see Frequency Response Chart). This linearization is implemented in DASY4 software versions later than 4.2. The uncertainty of the frequency response is included in the stated uncertainty of ConvF.
- DCP_{x,y,z}**: DCP are numerical linearization parameters assessed based on the data of power sweep with CW signal (no uncertainty required). DCP does not depend on frequency nor media.
- PAR**: PAR is the Peak to Average Ratio that is not calibrated but determined based on the signal characteristics
- A_{x,y,z}; B_{x,y,z}; C_{x,y,z}; VR_{x,y,z}**: A, B, C are numerical linearization parameters assessed based on the data of power sweep for specific modulation signal. The parameters do not depend on frequency nor media. VR is the maximum calibration range expressed in RMS voltage across the diode.
- ConvF and Boundary Effect Parameters**: Assessed in flat phantom using E-field (or Temperature Transfer Standard for $f \leq 800$ MHz) and inside waveguide using analytical field distributions based on power measurements for $f > 800$ MHz. The same setups are used for assessment of the parameters applied for boundary compensation (alpha, depth) of which typical uncertainty values are given. These parameters are used in DASY4 software to improve probe accuracy close to the boundary. The sensitivity in TSL corresponds to NORM_{x,y,z} * ConvF whereby the uncertainty corresponds to that given for ConvF. A frequency dependent ConvF is used in DASY version 4.4 and higher which allows extending the validity from ± 50 MHz to ± 100 MHz.
- Spherical isotropy (3D deviation from isotropy)**: in a field of low gradients realized using a flat phantom exposed by a patch antenna.
- Sensor Offset**: The sensor offset corresponds to the offset of virtual measurement center from the probe tip (on probe axis). No tolerance required.

Probe EX3DV4

SN:3814

Manufactured: September 2, 2011
Calibrated: September 22, 2011

Calibrated for DASY/EASY Systems
(Note: non-compatible with DASY2 system!)

DASY/EASY - Parameters of Probe: EX3DV4 - SN:3814

Basic Calibration Parameters

	Sensor X	Sensor Y	Sensor Z	Unc (k=2)
Norm ($\mu\text{V}/(\text{V}/\text{m})^2$) ^A	0.52	0.51	0.44	$\pm 10.1 \%$
DCP (mV) ^B	100.8	96.5	101.1	

Modulation Calibration Parameters

UID	Communication System Name	PAR		A dB	B dB	C dB	VR mV	Unc ^E (k=2)
10000	CW	0.00	X	0.00	0.00	1.00	121.7	$\pm 2.7 \%$
			Y	0.00	0.00	1.00	115.0	
			Z	0.00	0.00	1.00	105.3	

The reported uncertainty of measurement is stated as the standard uncertainty of measurement multiplied by the coverage factor $k=2$, which for a normal distribution corresponds to a coverage probability of approximately 95%.

^A The uncertainties of NormX,Y,Z do not affect the E^2 -field uncertainty inside TSL (see Pages 5 and 6).

^B Numerical linearization parameter: uncertainty not required.

^E Uncertainty is determined using the max. deviation from linear response applying rectangular distribution and is expressed for the square of the field value.

DASY/EASY - Parameters of Probe: EX3DV4 - SN:3814

Calibration Parameter Determined in Head Tissue Simulating Media

f (MHz) ^C	Relative Permittivity ^F	Conductivity (S/m) ^F	ConvF X	ConvF Y	ConvF Z	Alpha	Depth (mm)	Unct. (k=2)
450	43.5	0.87	9.55	9.55	9.55	0.12	1.00	± 13.4 %
750	41.9	0.89	9.26	9.26	9.26	0.80	0.67	± 12.0 %
900	41.5	0.97	8.75	8.75	8.75	0.71	0.73	± 12.0 %
1750	40.1	1.37	8.13	8.13	8.13	0.80	0.62	± 12.0 %
1900	40.0	1.40	7.78	7.78	7.78	0.80	0.61	± 12.0 %
2450	39.2	1.80	7.02	7.02	7.02	0.80	0.60	± 12.0 %

^C Frequency validity of ± 100 MHz only applies for DASY v4.4 and higher (see Page 2), else it is restricted to ± 50 MHz. The uncertainty is the RSS of the ConvF uncertainty at calibration frequency and the uncertainty for the indicated frequency band.

^F At frequencies below 3 GHz, the validity of tissue parameters (ϵ and σ) can be relaxed to ± 10% if liquid compensation formula is applied to measured SAR values. At frequencies above 3 GHz, the validity of tissue parameters (ϵ and σ) is restricted to ± 5%. The uncertainty is the RSS of the ConvF uncertainty for indicated target tissue parameters.

DASY/EASY - Parameters of Probe: EX3DV4 - SN:3814

Calibration Parameter Determined in Body Tissue Simulating Media

f (MHz) ^C	Relative Permittivity ^F	Conductivity (S/m) ^F	ConvF X	ConvF Y	ConvF Z	Alpha	Depth (mm)	Unct. (k=2)
450	56.7	0.94	10.39	10.39	10.39	0.04	1.00	± 13.4 %
750	55.5	0.96	9.28	9.28	9.28	0.80	0.65	± 12.0 %
900	55.0	1.05	8.92	8.92	8.92	0.80	0.65	± 12.0 %
1750	53.4	1.49	7.58	7.58	7.58	0.80	0.67	± 12.0 %
1900	53.3	1.52	7.31	7.31	7.31	0.80	0.68	± 12.0 %
2150	53.1	1.66	7.38	7.38	7.38	0.80	0.65	± 12.0 %
2450	52.7	1.95	7.15	7.15	7.15	0.80	0.50	± 12.0 %
2600	52.5	2.16	7.02	7.02	7.02	0.80	0.50	± 12.0 %
3700	51.0	3.55	6.35	6.35	6.35	0.26	1.68	± 13.1 %
5200	49.0	5.30	4.19	4.19	4.19	0.60	1.95	± 13.1 %
5500	48.6	5.65	3.86	3.86	3.86	0.60	1.95	± 13.1 %
5800	48.2	6.00	3.94	3.94	3.94	0.60	1.95	± 13.1 %

^C Frequency validity of ± 100 MHz only applies for DASY v4.4 and higher (see Page 2), else it is restricted to ± 50 MHz. The uncertainty is the RSS of the ConvF uncertainty at calibration frequency and the uncertainty for the indicated frequency band.

^F At frequencies below 3 GHz, the validity of tissue parameters (ϵ and σ) can be relaxed to ± 10% if liquid compensation formula is applied to measured SAR values. At frequencies above 3 GHz, the validity of tissue parameters (ϵ and σ) is restricted to ± 5%. The uncertainty is the RSS of the ConvF uncertainty for indicated target tissue parameters.

Frequency Response of E-Field (TEM-Cell:ifi110 EXX, Waveguide: R22)

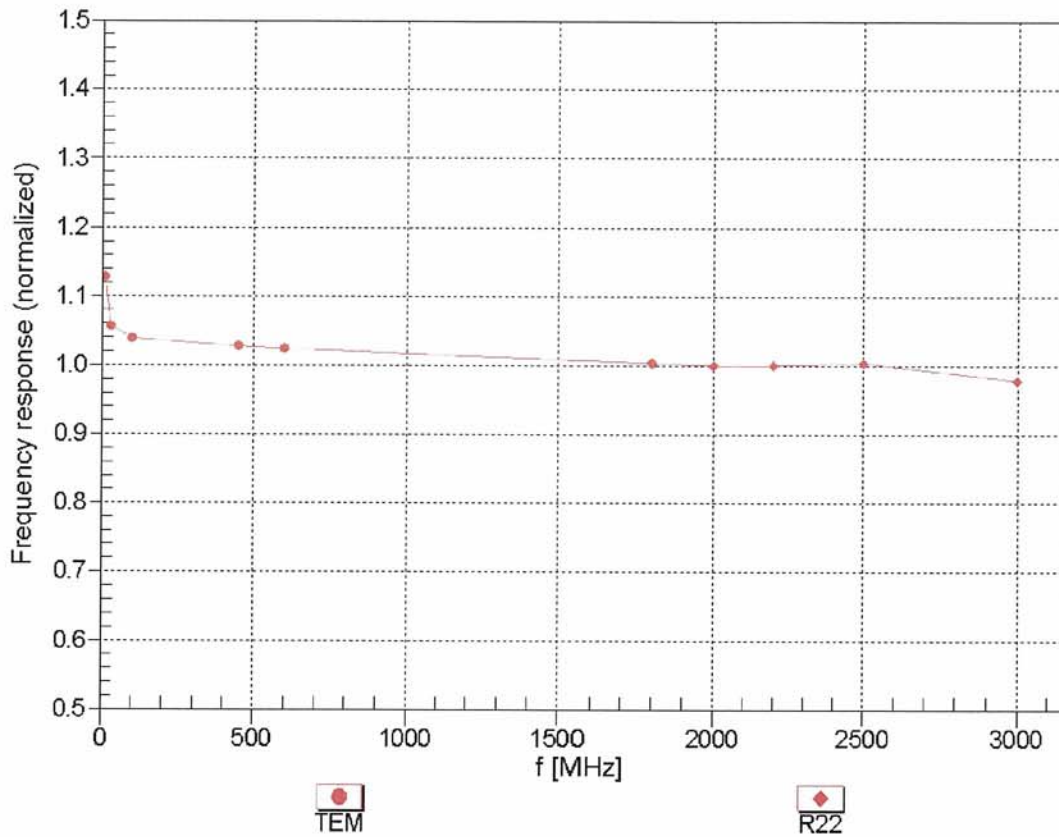

Uncertainty of Frequency Response of E-field: $\pm 6.3\%$ (k=2)

Receiving Pattern (ϕ), $\vartheta = 0^\circ$

f=600 MHz, TEM

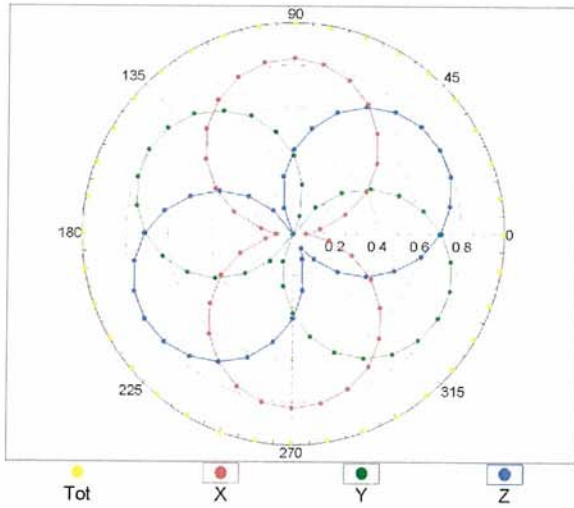

f=1800 MHz, R22

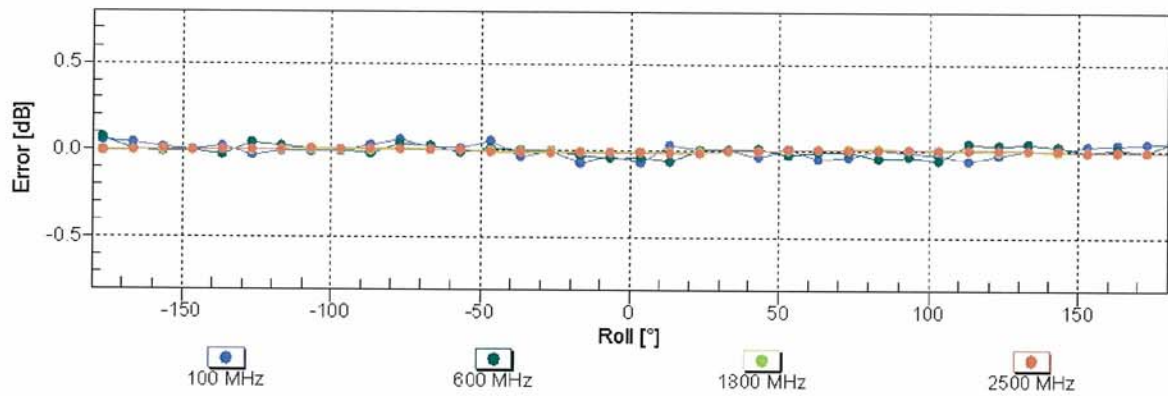
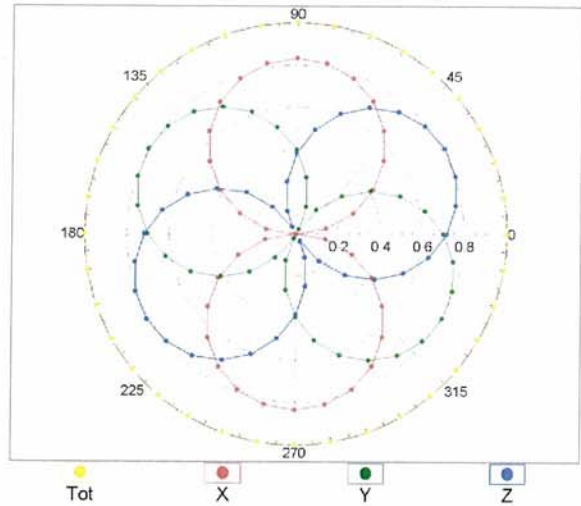

Uncertainty of Axial Isotropy Assessment: $\pm 0.5\%$ (k=2)

Dynamic Range $f(\text{SAR}_{\text{head}})$ (TEM cell , $f = 900 \text{ MHz}$)

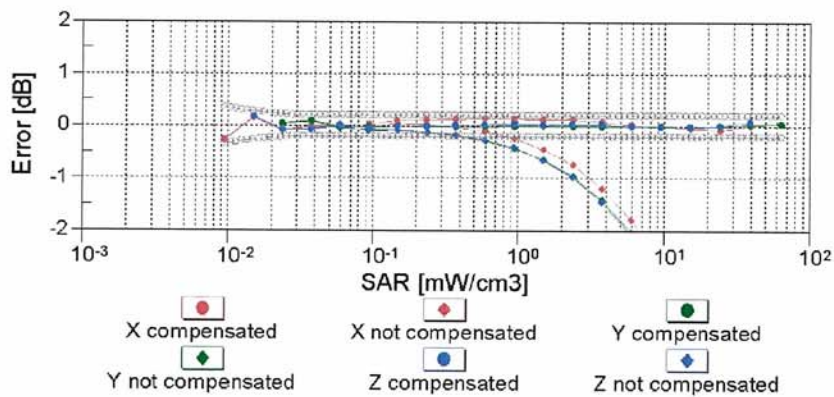
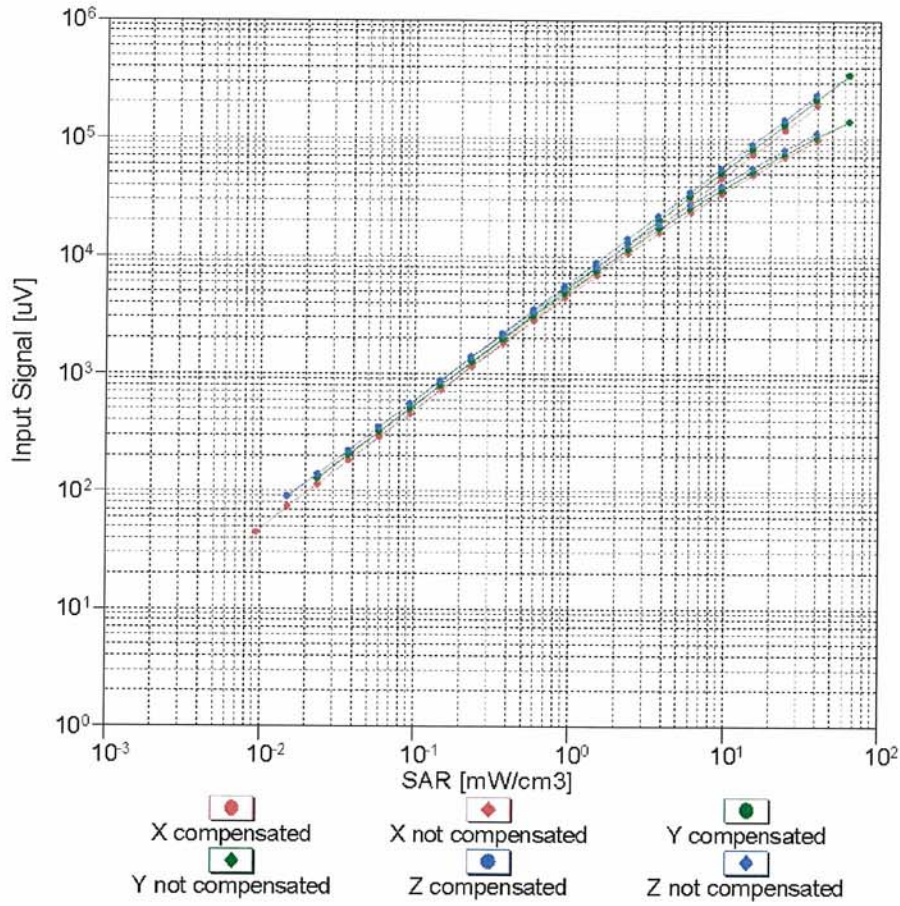

Uncertainty of Linearity Assessment: $\pm 0.6\%$ ($k=2$)

Conversion Factor Assessment

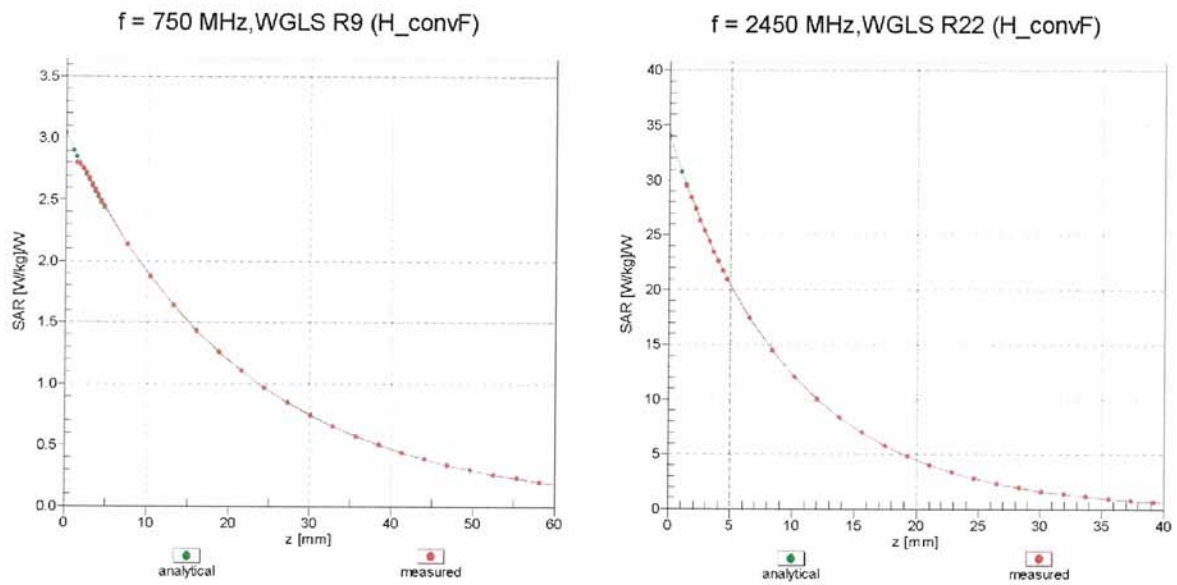

Deviation from Isotropy in Liquid Error (ϕ, θ), f = 900 MHz

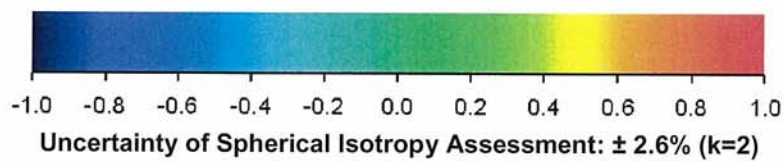
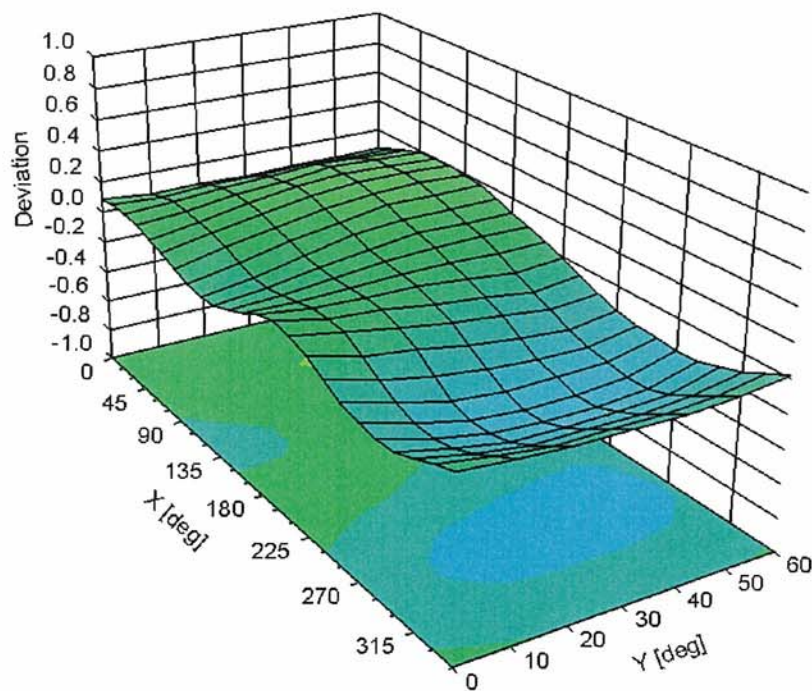

DASY/EASY - Parameters of Probe: EX3DV4 - SN:3814

Other Probe Parameters

Sensor Arrangement	Triangular
Connector Angle (°)	Not applicable
Mechanical Surface Detection Mode	enabled
Optical Surface Detection Mode	disabled
Probe Overall Length	337 mm
Probe Body Diameter	10 mm
Tip Length	9 mm
Tip Diameter	2.5 mm
Probe Tip to Sensor X Calibration Point	1 mm
Probe Tip to Sensor Y Calibration Point	1 mm
Probe Tip to Sensor Z Calibration Point	1 mm
Recommended Measurement Distance from Surface	2 mm

Appendix 2. Measurement Methods

A.2.1. Evaluation Procedure

The Specific Absorption Rate (SAR) evaluation was performed in the following manner:

- a) (i) The evaluation was performed in an applicable area of the phantom depending on the type of device being tested. For devices worn about the ear during normal operation, both the left and right ear positions were evaluated at the centre frequency of the band at maximum power. The side, which produced the greatest SAR, determined which side of the phantom would be used for the entire evaluation. The positioning of the head worn device relative to the phantom was dictated by the test specification identified in section 3.1 of this report.

(ii) For body worn devices or devices which can be operated within 20 cm of the body, the flat section of the SAM phantom was used were the size of the device(s) is normal. for bigger devices and base station the 2mm Oval phantom is used for evaluation. The type of device being evaluated dictated the distance of the EUT to the outer surface of the phantom flat section.
- b) The SAR was determined by a pre-defined procedure within the DASY4 software. The exposed region of the phantom was scanned near the inner surface with a grid spacing of 20mm x 20mm or appropriate resolution.
- c) A 5x5x7 matrix was performed around the greatest spatial SAR distribution found during the area scan of the applicable exposed region. SAR values were then calculated using a 3-D spline interpolation algorithm and averaged over spatial volumes of 1 and 10 grams.
- d) If the EUT had any appreciable drift over the course of the evaluation, then the EUT was re-evaluated. Any unusual anomalies over the course of the test also warranted a re-evaluation.

A.2.2. Specific Absorption Rate (SAR) Measurements to OET Bulletin 65 Supplement C: (2001-01)

Evaluating Compliance with FCC Guidelines for Human Exposure to Radio Frequency Electromagnetic Fields

SAR measurements were performed in accordance with Appendix D of the standard FCC OET Bulletin 65 Supplement C: 2001, IEEE 1528 and FCC KDB procedures, against appropriate limits for each measurement position in accordance with the standard. In some cases the FCC was contacted using a PBA or KDB process to ensure test is performed correctly.

The test was performed in a shielded enclosure with the temperature controlled to remain between +18.0°C and +25.0°C. The tissue equivalent material fluid temperature was controlled to give a maximum variation of $\pm 2.0^\circ\text{C}$

Prior to any SAR measurements on the EUT, system validation and material dielectric property measurements were conducted. In the absence of a detailed procedure within the specification, system validation and material dielectric property measurements were performed in accordance with Appendix C and Appendix D of FCC OET Bulletin 65 Supplement C: 2001 and FCC KDB publication 450824.

Following the successful system validation and material dielectric property measurements, a SAR versus time sweep shall be performed within 10 mm of the phantom inner surface. If the EUT power output is stable after three minutes then the measurement probe will perform a coarse surface level scan at each test position in order to ascertain the location of the maximum local SAR level. Once this area had been established, a 5x5x7 cube of 175 points (5 mm spacing in each axis $\approx 27\text{g}$) will be centred at the area of concern. Extrapolation and interpolation will then be carried out on the 27g of tissue and the highest averaged SAR over a 10g cube determined.

Once the maximum interpolated SAR measurement is complete; the coarse scan is visually assessed to check for secondary peaks within 50% of the maximum SAR level. If there are any further SAR measurements required, extra 5x5x7 cubes shall be centred on each of these extra local SAR maxima.

At the end of each position test case a second time sweep shall be performed to check whether the EUT has remained stable throughout the test.