



**TEST REPORT
FROM
RFI GLOBAL SERVICES LTD**

Test of: NTT docomo P-02C

To: OET Bulletin 65 Supplement C: (2001-01)

Test Report Serial No:
RFI/SAR3/RP78769JD09A

Supersedes Test Report Serial No's:
RFI/SAR1/RP78769JD09A and RFI/SAR/RP78769JD09A V2.0

This Test Report Is Issued Under The Authority Of Scott D'Adamo, Operations Manager Global Approvals:	
	
Checked By: Scott D'Adamo 	Report Copy No: PDF01
Issue Date: 21 September 2010	Test Dates: 27 August 2010

This report is issued in Adobe Acrobat portable document format (PDF). It is only a valid copy of the report if it is being viewed in PDF format with the following security options not allowed: Changing the document, Selecting text and graphics, Adding or changing notes and form fields.

This report may be copied in full. The results in this report apply only to the sample(s) tested.

Test of: NTT docomo P-02C

To: OET Bulletin 65 Supplement C: (2001-01)

This page has been left intentionally blank.

Test of: NTT docomo P-02C

To: OET Bulletin 65 Supplement C: (2001-01)

Table of Contents

1. Customer Information	4
2. Equipment Under Test (EUT).....	5
3. Test Specification, Methods and Procedures	8
4. Deviations from the Test Specification	9
5. Operation and Configuration of the EUT during Testing	10
6. Summary of Test Results.....	12
7. Measurements, Examinations and Derived Results.....	13
8. Measurement Uncertainty.....	18
Appendix 1. Test Equipment Used.....	21
Appendix 2. Measurement Methods	24
Appendix 3. SAR Distribution Scans	26
Appendix 4. Photographs	36
Appendix 5. Validation of System	54
Appendix 6. Simulated Tissues.....	55
Appendix 7. DASY4 System Details.....	56

Test of: NTT docomo P-02C

To: OET Bulletin 65 Supplement C: (2001-01)

1. Customer Information

Company Name:	Panasonic Mobile Communications Development of Europe Ltd
Address:	Panasonic House Willoughby Road Bracknell Berkshire RG12 8FP United Kingdom

Test of: NTT docomo P-02C

To: OET Bulletin 65 Supplement C: (2001-01)

2. Equipment Under Test (EUT)

2.1. Identification of Equipment Under Test (EUT)

Description:	Mobile Handset
Brand Name:	NTT docomo
Model Name or Number:	P-02C
Serial Number:	None Stated
IMEI Number:	352172040013568
Hardware Version Number:	Rev C
Software Version Number:	B-D02WP1-00.01.014 D02WP1_Cv10092802
Hardware Revision of GSM Module:	Not Applicable
Software Revision of GSM Module:	Not Applicable
FCC ID Number:	UCE110033A
Country of Manufacture:	Japan
Date of Receipt:	27 August 2010

2.2. Description of EUT

The Equipment Under Test is a UMTS cellular handset with RFID. The device operates in UMTS FDD V band.

2.3. Modifications Incorporated in the EUT

There were no modifications incorporated in the EUT during the test.

Test of: NTT docomo P-02C

To: OET Bulletin 65 Supplement C: (2001-01)

2.4. Accessories

The following accessories were supplied with the EUT during testing:

Description:	Battery
Brand Name:	NTT
Model Name or Number:	P20
Serial Number:	None Stated
Cable Length and Type:	Not Applicable
Country of Manufacture:	None Stated
Connected to Port	3 Pin Contact Point

Description:	Micro-SD Memory Card
Brand Name:	None Stated
Model Name or Number:	None Stated
Serial Number:	None Stated
Cable Length and Type:	Not Applicable
Country of Manufacture:	None Stated
Connected to Port	Dedicated micro-SD card port

2.5. Support Equipment

The following support equipment was used to exercise the EUT during testing:

Description:	Communication Test Set
Brand Name:	R&S
Model Name or Number:	CMU200
Serial Number:	101376
Cable Length and Type:	~2.0 m Utiflex RF cable
Connected to Port:	RF Input/ Output Port

Test of: NTT docomo P-02C

To: OET Bulletin 65 Supplement C: (2001-01)

2.6. Additional Information Related to Testing

Equipment Category	UMTS FDD V / RFID		
Type of Unit	Portable Transceiver		
Intended Operating Environment:	Within UMTS Coverage		
Transmitter Maximum Output Power Characteristics:	UMTS Band V	Communication Test Set was configured to allow the EUT to transmit at a maximum power of up to 24dBm.	
Transmitter Frequency Range:	UMTS Band V	(826 to 847) MHz	
Transmitter Frequency Allocation of EUT When Under Test:	Channel Number	Channel Description	Frequency (MHz)
	4132	Low	826.4
	4183	Middle	836.6
	4233	High	846.6
Modulation(s):	QPSK(UMTS / HSDPA): 0 Hz		
Modulation Scheme (Crest Factor):	QPSK(UMTS FDD / HSDPA): 1		
Antenna Type:	Internal		
Antenna Length:	Unknown		
Number of Antenna Positions:	1 fixed		
Power Supply Requirement:	3.7V		
Battery Type(s):	Li-ion		

Test of: NTT docomo P-02C

To: OET Bulletin 65 Supplement C: (2001-01)

3. Test Specification, Methods and Procedures

3.1. Test Specification

Reference:	OET Bulletin 65 Supplement C: (2001-01)
Title:	Evaluating Compliance with FCC Guidelines for Human Exposure to Radio Frequency Electromagnetic Fields.
Purpose of Test:	To determine whether the equipment met the basic restrictions as defined in OET Bulletin 65 Supplement C: (2001-01) using the SAR averaging method as described in the test specification above.

3.2. Methods and Procedures Reference Documentation

The methods and procedures used were as detailed in:

Federal Communications Commission, "Evaluating compliance with FCC Guidelines for human exposure to radio frequency electromagnetic fields", OET Bulletin 65 Supplement C, FCC, Washington, D.C, 20554, 2001.

Thomas Schmid, Oliver Egger and Neils Kuster, "Automated E-field scanning system for dosimetric assessments", IEEE Transaction on microwave theory and techniques, Vol. 44, pp. 105-113, January 1996.

Neils Kuster, Ralph Kastle and Thomas Schmid, "Dosimetric evaluation of mobile communications equipment with know precision", IEICE Transactions of communications, Vol. E80-B, No.5, pp. 645-652, May 1997.

KDB 447498 D01 Mobile Portable RF Exposure v04

KDB 648474 D01 SAR Handsets Multi Xmitter and Ant v01r05

KDB 941225 D01 SAR test for 3G devices v02

3.3. Definition of Measurement Equipment

The measurement equipment used complied with the requirements of the standards referenced in the methods & procedures section above. Appendix 1 contains a list of the test equipment used.

Test of: NTT docomo P-02C

To: OET Bulletin 65 Supplement C: (2001-01)

4. Deviations from the Test Specification

Test was performed as per "KDB 447498 D01 Mobile Portable RF Exposure v04", "KDB 648474 D01 SAR Handsets Multi Xmitter and Ant v01r05" and "KDB 941225 D01 SAR test for 3G devices v02", according to the handset procedures in IEEE Std 1528-2003, OET Bulletin 65 Supplement C 01-01 and the specific FCC test procedures.

3G Body SAR test was performed in the middle channel as the measured SAR levels were < 0.8 W/kg, where the transmission band corresponding to all channels were ≤ 100 MHz. Testing for the other channels were not required as stated in KDB 447498 D01.

Test of: NTT docomo P-02C

To: OET Bulletin 65 Supplement C: (2001-01)

5. Operation and Configuration of the EUT during Testing

5.1. Operating Modes

The EUT was tested in the following operating mode(s) unless otherwise stated:

- UMTS Band V call allocated RMC 12.2kbps
 - UMTS FDD V - RMC 12.2kbps + HSDPA With Test loop mode 1 and TPC bits configured to all "1's", Sub-test 1
 - 3G Body SAR test was performed in the middle channel as the measured SAR levels were < 0.8 W/kg, where the transmission band corresponding to all channels were \leq 100 MHz. Testing for the other channels were not required as stated in KDB 447498 D01.
 - Some points in the 'Right Touch' and 'Right Tilt' positions could not be fully evaluated therefore the zoom scan was unable to fully enclose the peak SAR location as required by IEEE 1528 and OET Bulletin 65 Supplement C. This scan is repeated in the Mouth / Jaw configuration on the SAM phantom flat section as per KDB 648474 D01.
 - Simultaneous Transmission is not supported by.
-

Test of: NTT docomo P-02C

To: OET Bulletin 65 Supplement C: (2001-01)

5.2. Configuration and Peripherals

The EUT was tested in the following configuration(s) unless otherwise stated:

- Standalone Battery Powered
- EUT tested in Head and Body-worn configuration. The applied configurations for body-worn orientations where the corresponding edge(s) is closest to the user with the most conservative exposure condition

Head Configuration

- a) The handset was placed in a normal operating position with the centre of the ear-piece aligned with the ear canal on the phantom.
- b) With the ear-piece touching the phantom the centre line of the handset was aligned with an imaginary plane (X and Y axis) consisting of three lines connecting both ears and the mouth.
- c) For the cheek position the handset was gradually moved towards the cheek until any point of the mouth-piece or keypad touched the cheek.
- d) For the tilted position the EUT was positioned as for the cheek position, and then the horizontal angle was increased by fifteen degrees (the phone keypad was moved away from the cheek by fifteen degrees).
- e) SAR measurements were evaluated at maximum power and the unit was operated for an appropriate period prior to the evaluation in order to minimise the drift.
- f) The device was keyed to operate continuously in the transmit mode for the duration of the test.
- g) The location of the maximum spatial SAR distribution (hot spot) was determined relative to the handset and its antenna.
- h) The EUT was transmitting at full power throughout the duration of the test powered by a fully charged battery.

Body Configuration

- a) The EUT was placed in a normal operating position where the centre of EUT was aligned with the centre reference point on the flat section of the 'SAM' phantom.
 - b) With the EUT touching the phantom at an imaginary centre line. The EUT was aligned with a marked plane (X and Y axis) consisting of two lines.
 - c) For the touch-safe position the handset was gradually moved towards the flat section of the 'SAM' phantom until any point of the EUT touched the phantom.
 - d) For position(s) greater than 0mm separation the EUT was positioned as per the touch-safe position, and then the vertical height was decreased/adjusted as required.
 - e) SAR measurements were evaluated at maximum power and the unit was operated for an appropriate period prior to the evaluation in order to minimise the drift.
 - f) The device was keyed to operate continuously in the transmit mode for the duration of the test.
 - g) The location of the maximum spatial SAR distribution (hot spot) was determined relative to the handset and its antenna.
 - h) The EUT was transmitting at full power throughout the duration of the test powered by a fully charged battery.
-

Test of: NTT docomo P-02C

To: OET Bulletin 65 Supplement C: (2001-01)

6. Summary of Test Results

Test Name	Specification Reference	Result
Specific Absorption Rate-UMTS Head Configuration 1g	OET Bulletin 65 Supplement C: 2001	Complied
Specific Absorption Rate-UMTS Body Configuration 1g	OET Bulletin 65 Supplement C: 2001	Complied
Specific Absorption Rate-HSDPA Body Configuration 1g	OET Bulletin 65 Supplement C: 2001	Complied

6.1. Location of Tests

All the measurements described in this report were performed at the premises of RFI Global Services Ltd, Pavilion A, Ashwood Park, Ashwood Way, Basingstoke, Hampshire, RG23 8BG United Kingdom

Test of: NTT docomo P-02C

To: OET Bulletin 65 Supplement C: (2001-01)

7. Measurements, Examinations and Derived Results

7.1. General Comments

This section contains test results only.

Measurement uncertainties are evaluated in accordance with current best practice. Our reported expanded uncertainties are based on standard uncertainties, which are multiplied by an appropriate coverage factor to provide a statistical confidence level of approximately 95%. Please refer to section 8 for details of measurement uncertainties.

Test of: NTT docomo P-02C

To: OET Bulletin 65 Supplement C: (2001-01)

7.2. Test Results**7.2.1. Specific Absorption Rate - UMTS FDD V Head Configuration 1g****Test Summary:**

Tissue Volume:	1g
Maximum Level (W/kg):	0.388

Environmental Conditions:

Temperature Variation in Lab (°C):	24.0 to 24.0
Temperature Variation in Liquid (°C):	23.5 to 23.5

Results:

EUT Position	Phantom Configuration	Channel Number	Level (W/kg)	Limit (W/kg)	Margin (W/kg)	Note(s)	Result
Touch	Left	4183	0.388	1.600	1.212	1, 2	Complied
Tilt	Left	4183	0.069	1.600	1.531	1, 2	Complied
Mouth / Jaw *	Right	4183	0.301	1.600	1.299	1, 2, 3	Complied
Mouth / Jaw *	Right	4183	0.070	1.600	1.530	1, 2, 3	Complied

Note(s):

1. SAR test was performed in the middle channel only as the measured levels were < 50% of the SAR limit as stated in the FCC Public Notice DA 02-1438 by the SCC-34/SC-2.
2. 12.2 kbps RMC with TPC bits configured to all "1's".
3. The phone was positioned with the hinge against a smooth edge of the flat phantom where the upper half of the phone was unfolded and extended beyond the phantom side wall. The lower half of the phone was secured in the test device holder at a fixed distance

*Some points in the Touch Right and Tilt Right positions could not be fully evaluated therefore the zoom scan was unable to fully enclose the peak SAR location as required by IEEE 1528 and OET Bulletin 65 Supplement C. These scans are repeated in the Mouth / Jaw configuration on the SAM phantom flat section as per KDB 648474 D01.

Test of: NTT docomo P-02C

To: OET Bulletin 65 Supplement C: (2001-01)

7.2.2. Specific Absorption Rate - UMTS FDD V Body Configuration 1g**Test Summary:**

Tissue Volume:	1g
Maximum Level (W/kg):	0.529

Environmental Conditions:

Temperature Variation in Lab (°C):	24.0 to 24.0
Temperature Variation in Liquid (°C):	23.5 to 23.5

Results:

EUT Position	Phantom Configuration	Channel Number	Level (W/kg)	Limit (W/kg)	Margin (W/kg)	Note(s)	Result
Front of EUT Open Facing Phantom	Flat (SAM)	4183	0.243	1.600	1.357	1, 2, 3	Complied
Rear of EUT Open Facing Phantom	Flat (SAM)	4183	0.529	1.600	1.071	1, 2, 3	Complied
Rear of EUT Open Facing Phantom With PHF	Flat (SAM)	4183	0.412	1.600	1.188	1, 2, 3	Complied

Note(s):

- SAR test was performed in the middle channel only as the measured levels were < 50% of the SAR limit as stated in the FCC Public Notice DA 02-1438 by the SCC-34/SC-2.
- SAR measurements were performed with the EUT at a separation distance of 15mm from the 'SAM' phantom flat section.
- 12.2 kbps RMC with TPC bits configured to all "1's".

Test of: NTT docomo P-02C

To: OET Bulletin 65 Supplement C: (2001-01)

7.2.3. Specific Absorption Rate – UMTS FDD V + HSDPA Body Configuration 1g**Test Summary:**

Tissue Volume:	1g
Maximum Level (W/kg):	0.528

Environmental Conditions:

Temperature Variation in Lab (°C):	24.0 to 24.0
Temperature Variation in Liquid (°C):	23.5 to 23.5

Results:

EUT Position	Phantom Configuration	Channel Number	Level (W/kg)	Limit (W/kg)	Margin (W/kg)	Note(s)	Result
Rear of EUT Open Facing Phantom	Flat (SAM)	4183	0.528	1.600	1.072	1, 2, 3	Complied

Note(s):

- SAR test was performed in the middle channel only as the measured levels were < 50% of the SAR limit as stated in the FCC Public Notice DA 02-1438 by the SCC-34/SC-2.
- SAR measurements were performed with the EUT at a separation distance of 15mm from the 'SAM' phantom flat section.
- HSDPA Enabled using FRC with H-Set 1, Test loop mode 1 and TPC bits configured to all "1's", Sub-test 1.

Test of: NTT docomo P-02C

To: OET Bulletin 65 Supplement C: (2001-01)

7.2.4. Conducted Average Power Measurement

Modes		HSDPA				WCDMA
Sets		1	2	3	4	Voice / RMC12.2kbps
Band	Channel	Power (dBm) Avg	Power (dBm) Avg	Power (dBm) Avg	Power (dBm) Avg	Power (dBm) Avg
850	4132	22.6	19.9	18.9	18.9	22.6
	4183	22.7	19.7	19.0	18.9	22.6
	4233	22.5	19.6	18.7	18.7	22.5
β_c		2	12	15	15	
β_d		15	15	8	4	
$\Delta_{ACK}, \Delta_{NACK}, \Delta_{CQI}$		8	8	8	8	

Sub-test 1 Setup for Release 5 HSDPA

Sub-test	β_c	β_d	B_d (SF)	β_c/β_d	$\beta_{hs}^{(1)}$	SM (dB) ⁽²⁾
1	2/15	15/15	64	2/15	4/15	0.0
2	12/15 ⁽³⁾	15/15 ⁽³⁾	64	12/15 ⁽³⁾	24/15	1.0
3	15/15	8/15	64	15/8	30/15	1.5
4	15/15	4/15	64	15/4	30/15	1.5

Note 1: $\Delta_{ACK}, \Delta_{NACK}$ and $\Delta_{CQI} = 8 \Leftrightarrow A_{hs} = \beta_{hs}/\beta_c = 30/15 \Leftrightarrow \beta_{hs} = 30/15 * \beta_c$ Note 2: CM = 1 for $\beta_c/\beta_d = 12/15, B_{hs}/\beta_c = 24/15$ Note 3: For subtest 2 the β_c/β_d ratio of 12/15 for the TFC during the measurement period (TF1, TF0) is achieved by setting the signalled gain factors for the reference TFC (TF1, TF1) to $\beta_c = 11/15$ and $\beta_d = 15/15$

Test of: NTT docomo P-02C

To: OET Bulletin 65 Supplement C: (2001-01)

8. Measurement Uncertainty

No measurement or test can ever be perfect and the imperfections give rise to error of measurement in the results. Consequently, the result of a measurement is only an approximation to the value of the measurand (the specific quantity subject to measurement) and is only complete when accompanied by a statement of the uncertainty of the approximation.

The expression of uncertainty of a measurement result allows realistic comparison of results with reference values and limits given in specifications and standards.

The uncertainty of the result may need to be taken into account when interpreting the measurement results.

The reported expanded uncertainties below are based on a standard uncertainty multiplied by an appropriate coverage factor, such that a confidence level of approximately 95% is maintained. For the purposes of this document “approximately” is interpreted as meaning “effectively” or “for most practical purposes”.

Test Name	Confidence Level	Calculated Uncertainty
Specific Absorption Rate- UMTS850 Head Configuration 1g	95%	19.28%
Specific Absorption Rate- UMTS850 Body Configuration 1g	95%	19.41%

The methods used to calculate the above uncertainties are in line with those recommended within the various measurement specifications. Where measurement specifications do not include guidelines for the evaluation of measurement uncertainty, the published guidance of the appropriate accreditation body is followed.

Test of: NTT docomo P-02C

To: OET Bulletin 65 Supplement C: (2001-01)

Measurement Uncertainty (Continued)**8.1. Specific Absorption Rate Uncertainty at 850 MHz Head 1g, UMTS Modulation Scheme calculated in accordance with IEC 62209 & IEEE 1528**

Type	Source of uncertainty	+ Value	- Value	Probability Distribution	Divisor	C _i (10g)	Standard Uncertainty		v _i or v _{eff}
							+ u (%)	- u (%)	
B	Probe calibration	11.000	11.000	normal (k=2)	2.0000	1.0000	5.500	5.500	∞
B	Axial Isotropy	0.500	0.500	normal (k=2)	2.0000	1.0000	0.250	0.250	∞
B	Hemispherical Isotropy	2.600	2.600	normal (k=2)	2.0000	1.0000	1.300	1.300	∞
B	Spatial Resolution	0.500	0.500	Rectangular	1.7321	1.0000	0.289	0.289	∞
B	Boundary Effect	0.769	0.769	Rectangular	1.7321	1.0000	0.444	0.444	∞
B	Linearity	0.600	0.600	Rectangular	1.7321	1.0000	0.346	0.346	∞
B	Detection Limits	0.200	0.200	Rectangular	1.7321	1.0000	0.115	0.115	∞
B	Readout Electronics	0.320	0.320	normal (k=2)	2.0000	1.0000	0.160	0.160	∞
B	Response Time	0.000	0.000	Rectangular	1.7321	1.0000	0.000	0.000	∞
B	Integration Time	0.000	0.000	Rectangular	1.7321	1.0000	0.000	0.000	∞
B	RF Ambient conditions	3.000	3.000	Rectangular	1.7321	1.0000	1.732	1.732	∞
B	Probe Positioner Mechanical Restrictions	4.000	4.000	Rectangular	1.7321	1.0000	2.309	2.309	∞
B	Probe Positioning with regard to Phantom Shell	2.850	2.850	Rectangular	1.7321	1.0000	1.645	1.645	∞
B	Extrapolation and integration/ Maximum SAR evaluation	5.080	5.080	Rectangular	1.7321	1.0000	2.933	2.933	∞
A	Test Sample Positioning	2.400	2.400	normal (k=1)	1.0000	1.0000	2.400	2.400	10
A	Device Holder uncertainty	0.154	0.154	normal (k=1)	1.0000	1.0000	0.154	0.154	10
B	Phantom Uncertainty	4.000	4.000	Rectangular	1.7321	1.0000	2.309	2.309	∞
B	Drift of output power	5.000	5.000	Rectangular	1.7321	1.0000	2.887	2.887	∞
B	Liquid Conductivity (target value)	5.000	5.000	Rectangular	1.7321	0.6400	1.848	1.848	∞
A	Liquid Conductivity (measured value)	4.920	4.920	normal (k=1)	1.0000	0.6400	3.149	3.149	5
B	Liquid Permittivity (target value)	5.000	5.000	Rectangular	1.7321	0.6000	1.732	1.732	∞
A	Liquid Permittivity (measured value)	4.970	4.970	normal (k=1)	1.0000	0.6000	2.982	2.982	5
	Combined standard uncertainty			t-distribution			9.84	9.84	>200
	Expanded uncertainty			k = 1.96			19.28	19.28	>200

Test of: NTT docomo P-02C

To: OET Bulletin 65 Supplement C: (2001-01)

8.2. Specific Absorption Rate Uncertainty at 850 MHz Body 1g, UMTS Modulation Scheme calculated in accordance with IEC 62209 & IEEE 1528

Type	Source of uncertainty	+ Value	- Value	Probability Distribution	Divisor	C _i (10g)	Standard Uncertainty		v _i or v _{eff}
							+ u (%)	- u (%)	
B	Probe calibration	11.000	11.000	normal (k=2)	2.0000	1.0000	5.500	5.500	∞
B	Axial Isotropy	0.500	0.500	normal (k=2)	2.0000	1.0000	0.250	0.250	∞
B	Hemispherical Isotropy	2.600	2.600	normal (k=2)	2.0000	1.0000	1.300	1.300	∞
B	Spatial Resolution	0.500	0.500	Rectangular	1.7321	1.0000	0.289	0.289	∞
B	Boundary Effect	0.769	0.769	Rectangular	1.7321	1.0000	0.444	0.444	∞
B	Linearity	0.600	0.600	Rectangular	1.7321	1.0000	0.346	0.346	∞
B	Detection Limits	0.200	0.200	Rectangular	1.7321	1.0000	0.115	0.115	∞
B	Readout Electronics	0.320	0.320	normal (k=2)	2.0000	1.0000	0.160	0.160	∞
B	Response Time	0.000	0.000	Rectangular	1.7321	1.0000	0.000	0.000	∞
B	Integration Time	0.000	0.000	Rectangular	1.7321	1.0000	0.000	0.000	∞
B	RF Ambient conditions	3.000	3.000	Rectangular	1.7321	1.0000	1.732	1.732	∞
B	Probe Positioner Mechanical Restrictions	4.000	4.000	Rectangular	1.7321	1.0000	2.309	2.309	∞
B	Probe Positioning with regard to Phantom Shell	2.850	2.850	Rectangular	1.7321	1.0000	1.645	1.645	∞
B	Extrapolation and integration/ Maximum SAR evaluation	5.080	5.080	Rectangular	1.7321	1.0000	2.933	2.933	∞
A	Test Sample Positioning	2.900	2.900	normal (k=1)	1.0000	1.0000	2.900	2.900	10
A	Device Holder uncertainty	0.154	0.154	normal (k=1)	1.0000	1.0000	0.154	0.154	10
B	Phantom Uncertainty	4.000	4.000	Rectangular	1.7321	1.0000	2.309	2.309	∞
B	Drift of output power	5.000	5.000	Rectangular	1.7321	1.0000	2.887	2.887	∞
B	Liquid Conductivity (target value)	5.000	5.000	Rectangular	1.7321	0.6400	1.848	1.848	∞
A	Liquid Conductivity (measured value)	4.690	4.690	normal (k=1)	1.0000	0.6400	3.002	3.002	5
B	Liquid Permittivity (target value)	5.000	5.000	Rectangular	1.7321	0.6000	1.732	1.732	∞
A	Liquid Permittivity (measured value)	4.860	4.860	normal (k=1)	1.0000	0.6000	2.916	2.916	5
	Combined standard uncertainty			t-distribution			9.91	9.91	>250
	Expanded uncertainty			k = 1.96			19.41	19.41	>250

Test of: NTT docomo P-02C

To: OET Bulletin 65 Supplement C: (2001-01)

Appendix 1. Test Equipment Used

RFI No.	Instrument	Manufacturer	Type No.	Serial No.	Date Last Calibrated	Cal. Interval (Months)
A034	Narda 20W Termination	Narda	374BNM	8706	Calibrated as part of system	-
A1097	SMA Directional Coupler	MiDISCO	MDC6223-30	None	Calibrated as part of system	-
A1137	3dB Attenuator	Narda	779	4690	Calibrated as part of system	-
A1174	Dielectric Probe Kit	Agilent Technologies	85070C	Us99360072	Calibrated before use	-
A1182	Handset Positioner	Schmid & Partner	V3.0	None	-	-
A1184	Data Acquisition Electronics	Schmid & Partner Engineering AG	DAE3	394	09 April 2010	12
A1238	SAM Phantom	Schmid & Partner Engineering AG	SAM b	001	Calibrated before use	-
A1328	Handset Positioner	Schmid & Partner Engineering AG	Modification	SD 000 H01 DA	-	-
A1329	900 MHz Dipole Kit	Schmid & Partner Engineering AG	D900V2	185	18 Aug 2009	24
A1378	Probe	Schmid & Partner Engineering AG	EX3 DV3	3508	15 July 2010	12
A1497	Amplifier	Mini-Circuits	zhl-42w (sma)	e020105	Calibrated as part of system	-
A1566	SAM Phantom	Schmid & Partner Engineering AG	SAM a	002	Calibrated before use	-
A1990	Digital Camera	Samsung	AS15	A23WC908A 05431K	-	-
C1144	Cable	Rosenberger MICRO-COAX	FA147AF0 01503030	41842-1	Calibrated as part of system	-
C1145	Cable	Rosenberger MICRO-COAX	FA147AF0 03003030	41843-1	Calibrated as part of system	-
C1146	Cable	Rosenberger MICRO-COAX	FA147AF0 30003030	41752-1	Calibrated as part of system	-

Test of: NTT docomo P-02C

To: OET Bulletin 65 Supplement C: (2001-01)

RFI No.	Instrument	Manufacturer	Type No.	Serial No.	Date Last Calibrated	Cal. Interval (Months)
G0528	Robot Power Supply	Schmid & Partner Engineering AG	DASY4	None	Calibrated before use	-
G087	PSU	Thurlby Thandar	CPX200	100701	Calibrated before use	-
M1015	Network Analyser	Agilent Technologies	8753ES	US39172406	15 Sept 2009	12
M1047	Robot Arm	Staubli	RX908 L	F00/SD89A1/A/01	Calibrated before use	-
M1159	Signal Generator	Agilent Technologies	E8241A	US42110332	Internal Checked 16 Aug 2010	4
M1270	Temperature/Humidity / Meter	RS Components	None	None	Internal Calibration 31 Mar 2010	12
M1071	Spectrum Analyzer	Agilent	HP8590E	3647U00514	Monitoring	-
M1044	Diode Power Sensor	Rohde & Schwarz	NRV-Z1	893350/019	26 May 2010	12
M265	Diode Power Sensor	Rohde & Schwarz	NRV-Z1	893350/017	26 May 2010	12
M263	Dual Channel Power Meter	Rohde & Schwarz	NRVD	826558/004	27 May 2010	12
M1144	Immersion Probe & Thermometer	Testo	110	03100047	27 May 2010	12
S256	SAR lab	RFI	Chamber	Site 4405	Calibrated before use	-

Test of: NTT docomo P-02C

To: OET Bulletin 65 Supplement C: (2001-01)

A.1.1. Calibration Certificates

This section contains the calibration certificates and data for the Probe(s) and Dipole(s) used, which are not included in the total number of pages for this report.

rechecked by *AKD*
27-05-2010

A1329

**Calibration Laboratory of
Schmid & Partner
Engineering AG**
Zeughausstrasse 43, 8004 Zurich, Switzerland



S Schweizerischer Kalibrierdienst
C Service suisse d'étalonnage
S Servizio svizzero di taratura
S Swiss Calibration Service

Accredited by the Swiss Accreditation Service (SAS)
The Swiss Accreditation Service is one of the signatories to the EA
Multilateral Agreement for the recognition of calibration certificates

Accreditation No.: **SCS 108**

Client **RFI**

Certificate No: **D900V2-185_Aug09**

CALIBRATION CERTIFICATE

Object **D900V2 - SN: 185**

Calibration procedure(s) **QA CAL-05.v7
Calibration procedure for dipole validation kits**

Calibration date: **August 18, 2009**

Condition of the calibrated item **In Tolerance**

This calibration certificate documents the traceability to national standards, which realize the physical units of measurements (SI).
The measurements and the uncertainties with confidence probability are given on the following pages and are part of the certificate.

All calibrations have been conducted in the closed laboratory facility: environment temperature (22 ± 3)°C and humidity < 70%.

Calibration Equipment used (M&TE critical for calibration)

Primary Standards	ID #	Cal Date (Certificate No.)	Scheduled Calibration
Power meter EPM-442A	GB37480704	08-Oct-08 (No. 217-00898)	Oct-09
Power sensor HP 8481A	US37292783	08-Oct-08 (No. 217-00898)	Oct-09
Reference 20 dB Attenuator	SN: 5086 (20g)	31-Mar-09 (No. 217-01025)	Mar-10
Type-N mismatch combination	SN: 5047.2 / 06327	31-Mar-09 (No. 217-01029)	Mar-10
Reference Probe ES3DV3	SN: 3205	26-Jun-09 (No. ES3-3205_Jun09)	Jun-10
DAE4	SN: 601	07-Mar-09 (No. DAE4-601_Mar09)	Mar-10
Secondary Standards	ID #	Check Date (in house)	Scheduled Check
Power sensor HP 8481A	MY41092317	18-Oct-02 (in house check Oct-07)	In house check: Oct-09
RF generator R&S SMT-06	100005	4-Aug-99 (in house check Oct-07)	In house check: Oct-09
Network Analyzer HP 8753E	US37390585 S4206	18-Oct-01 (in house check Oct-08)	In house check: Oct-09

	Name	Function	Signature
Calibrated by:	Jeton Kastrati	Laboratory Technician	
Approved by:	Katja Pokovic	Technical Manager	

Issued: August 18, 2009

This calibration certificate shall not be reproduced except in full without written approval of the laboratory.



Accredited by the Swiss Accreditation Service (SAS)
The Swiss Accreditation Service is one of the signatories to the EA
Multilateral Agreement for the recognition of calibration certificates

Accreditation No.: **SCS 108**

Glossary:

TSL	tissue simulating liquid
ConvF	sensitivity in TSL / NORM x,y,z
N/A	not applicable or not measured

Calibration is Performed According to the Following Standards:

- a) IEEE Std 1528-2003, "IEEE Recommended Practice for Determining the Peak Spatial-Averaged Specific Absorption Rate (SAR) in the Human Head from Wireless Communications Devices: Measurement Techniques", December 2003
- b) IEC 62209-1, "Procedure to measure the Specific Absorption Rate (SAR) for hand-held devices used in close proximity to the ear (frequency range of 300 MHz to 3 GHz)", February 2005
- c) Federal Communications Commission Office of Engineering & Technology (FCC OET), "Evaluating Compliance with FCC Guidelines for Human Exposure to Radiofrequency Electromagnetic Fields; Additional Information for Evaluating Compliance of Mobile and Portable Devices with FCC Limits for Human Exposure to Radiofrequency Emissions", Supplement C (Edition 01-01) to Bulletin 65

Additional Documentation:

- d) DASY4/5 System Handbook

Methods Applied and Interpretation of Parameters:

- *Measurement Conditions:* Further details are available from the Validation Report at the end of the certificate. All figures stated in the certificate are valid at the frequency indicated.
- *Antenna Parameters with TSL:* The dipole is mounted with the spacer to position its feed point exactly below the center marking of the flat phantom section, with the arms oriented parallel to the body axis.
- *Feed Point Impedance and Return Loss:* These parameters are measured with the dipole positioned under the liquid filled phantom. The impedance stated is transformed from the measurement at the SMA connector to the feed point. The Return Loss ensures low reflected power. No uncertainty required.
- *Electrical Delay:* One-way delay between the SMA connector and the antenna feed point. No uncertainty required.
- *SAR measured:* SAR measured at the stated antenna input power.
- *SAR normalized:* SAR as measured, normalized to an input power of 1 W at the antenna connector.
- *SAR for nominal TSL parameters:* The measured TSL parameters are used to calculate the nominal SAR result.

Measurement Conditions

DASY system configuration, as far as not given on page 1.

DASY Version	DASY5	V5.0
Extrapolation	Advanced Extrapolation	
Phantom	Modular Flat Phantom V4.9	
Distance Dipole Center - TSL	15 mm	with Spacer
Zoom Scan Resolution	dx, dy, dz = 5 mm	
Frequency	900 MHz \pm 1 MHz	

Head TSL parameters

The following parameters and calculations were applied.

	Temperature	Permittivity	Conductivity
Nominal Head TSL parameters	22.0 °C	41.5	0.97 mho/m
Measured Head TSL parameters	(22.0 \pm 0.2) °C	40.4 \pm 6 %	0.96 mho/m \pm 6 %
Head TSL temperature during test	(22.4 \pm 0.2) °C	----	----

SAR result with Head TSL

SAR averaged over 1 cm ³ (1 g) of Head TSL	Condition	
SAR measured	250 mW input power	2.75 mW / g
SAR normalized	normalized to 1W	11.0 mW / g
SAR for nominal Head TSL parameters ¹	normalized to 1W	11.0 mW / g \pm 17.0 % (k=2)

SAR averaged over 10 cm ³ (10 g) of Head TSL	condition	
SAR measured	250 mW input power	1.76 mW / g
SAR normalized	normalized to 1W	7.04 mW / g
SAR for nominal Head TSL parameters ¹	normalized to 1W	7.06 mW / g \pm 16.5 % (k=2)

¹ Correction to nominal TSL parameters according to d), chapter "SAR Sensitivities"

Body TSL parameters

The following parameters and calculations were applied.

	Temperature	Permittivity	Conductivity
Nominal Body TSL parameters	22.0 °C	55.0	1.05 mho/m
Measured Body TSL parameters	(22.0 ± 0.2) °C	52.7 ± 6 %	1.06 mho/m ± 6 %
Body TSL temperature during test	(22.0 ± 0.2) °C	----	----

SAR result with Body TSL

SAR averaged over 1 cm ³ (1 g) of Body TSL	Condition	
SAR measured	250 mW input power	2.80 mW / g
SAR normalized	normalized to 1W	11.2 mW / g
SAR for nominal Body TSL parameters ²	normalized to 1W	11.0 mW / g ± 17.0 % (k=2)

SAR averaged over 10 cm ³ (10 g) of Body TSL	condition	
SAR measured	250 mW input power	1.81 mW / g
SAR normalized	normalized to 1W	7.24 mW / g
SAR for nominal Body TSL parameters ²	normalized to 1W	7.16 mW / g ± 16.5 % (k=2)

² Correction to nominal TSL parameters according to d), chapter "SAR Sensitivities"

Appendix

Antenna Parameters with Head TSL

Impedance, transformed to feed point	49.5 Ω - 10.3 j Ω
Return Loss	- 19.7 dB

Antenna Parameters with Body TSL

Impedance, transformed to feed point	45.5 Ω - 11.2 j Ω
Return Loss	- 18.0 dB

General Antenna Parameters and Design

Electrical Delay (one direction)	1.403 ns
----------------------------------	----------

After long term use with 100W radiated power, only a slight warming of the dipole near the feedpoint can be measured.

The dipole is made of standard semirigid coaxial cable. The center conductor of the feeding line is directly connected to the second arm of the dipole. The antenna is therefore short-circuited for DC-signals.

No excessive force must be applied to the dipole arms, because they might bend or the soldered connections near the feedpoint may be damaged.

Additional EUT Data

Manufactured by	SPEAG
Manufactured on	May 27, 2003

DASY5 Validation Report for Head TSL

Date/Time: 18.08.2009 08:57:04

Test Laboratory: SPEAG, Zurich, Switzerland

DUT: Dipole 900 MHz; Type: D900V2; Serial: D900V2 - SN:185

Communication System: CW-900; Frequency: 900 MHz; Duty Cycle: 1:1

Medium: HSL 900 MHz

Medium parameters used: $f = 900$ MHz; $\sigma = 0.96$ mho/m; $\epsilon_r = 40.6$; $\rho = 1000$ kg/m³

Phantom section: Flat Section

Measurement Standard: DASY5 (IEEE/IEC)

DASY5 Configuration:

- Probe: ES3DV3 - SN3205; ConvF(5.88, 5.88, 5.88); Calibrated: 26.06.2009
- Sensor-Surface: 3mm (Mechanical Surface Detection)
- Electronics: DAE4 Sn601; Calibrated: 07.03.2009
- Phantom: Flat Phantom 4.9L; Type: QD000P49AA; Serial: 1001
- Measurement SW: DASY5, V5.0 Build 120; SEMCAD X Version 13.4 Build 45

Pin=250mW; dip=15mm/Zoom Scan (7x7x7)/Cube 0: Measurement grid: dx=5mm, dy=5mm, dz=5mm

Reference Value = 59.7 V/m; Power Drift = 0.015 dB

Peak SAR (extrapolated) = 4.17 W/kg

SAR(1 g) = 2.75 mW/g; SAR(10 g) = 1.76 mW/g

Maximum value of SAR (measured) = 3.23 mW/g

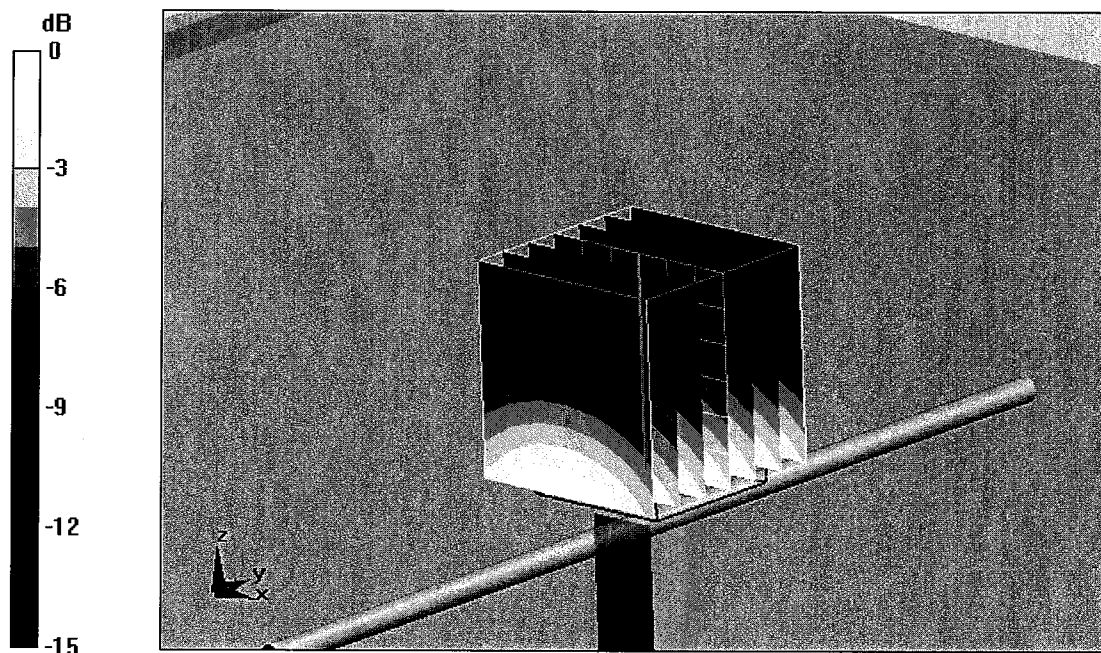

0 dB = 3.23mW/g

Impedance Measurement Plot for Head TSL

18 Aug 2009 08:06:03

CH1 S11 1 U FS 1: 49.496 Ω -10.342 Ω 17.099 pF 900.000 000 MHz

*
Del
Cor
Avg
16
↑

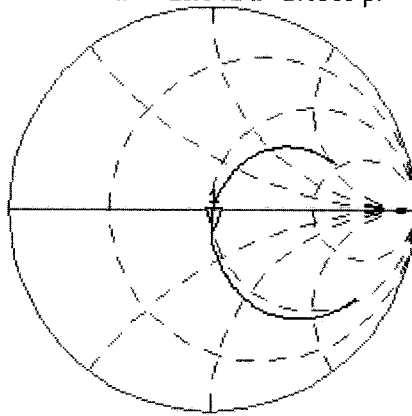

CH2 S11 LOG 5 dB/REF -20 dB 1: -19.698 dB 900.000 000 MHz

Cor
Avg
16
↑

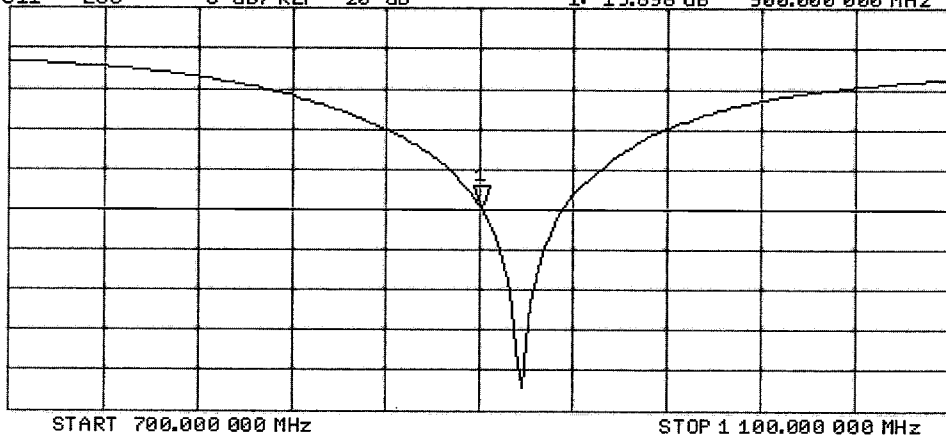

DASY5 Validation Report for Body

Date/Time: 17.08.2009 11:23:13

Test Laboratory: SPEAG, Zurich, Switzerland

DUT: Dipole 900 MHz; Type: D900V2; Serial: D900V2 - SN:185

Communication System: CW-900; Frequency: 900 MHz; Duty Cycle: 1:1

Medium: MSL900

Medium parameters used: $f = 900$ MHz; $\sigma = 1.06$ mho/m; $\epsilon_r = 52.7$; $\rho = 1000$ kg/m³

Phantom section: Flat Section

Measurement Standard: DASY5 (IEEE/IEC)

DASY5 Configuration:

- Probe: ES3DV3 - SN3205; ConvF(5.81, 5.81, 5.81); Calibrated: 26.06.2009
- Sensor-Surface: 3mm (Mechanical Surface Detection)
- Electronics: DAE4 Sn601; Calibrated: 07.03.2009
- Phantom: Flat Phantom 4.9L; Type: QD000P49AA; Serial: 1001
- Measurement SW: DASY5, V5.0 Build 120; SEMCAD X Version 13.4 Build 45

Pin=250mW; dip=15mm/Zoom Scan (7x7x7)/Cube 0: Measurement grid: dx=5mm, dy=5mm, dz=5mm

Reference Value = 57.2 V/m; Power Drift = 0.00569 dB

Peak SAR (extrapolated) = 4.19 W/kg

SAR(1 g) = 2.8 mW/g; SAR(10 g) = 1.81 mW/g

Maximum value of SAR (measured) = 3.24 mW/g

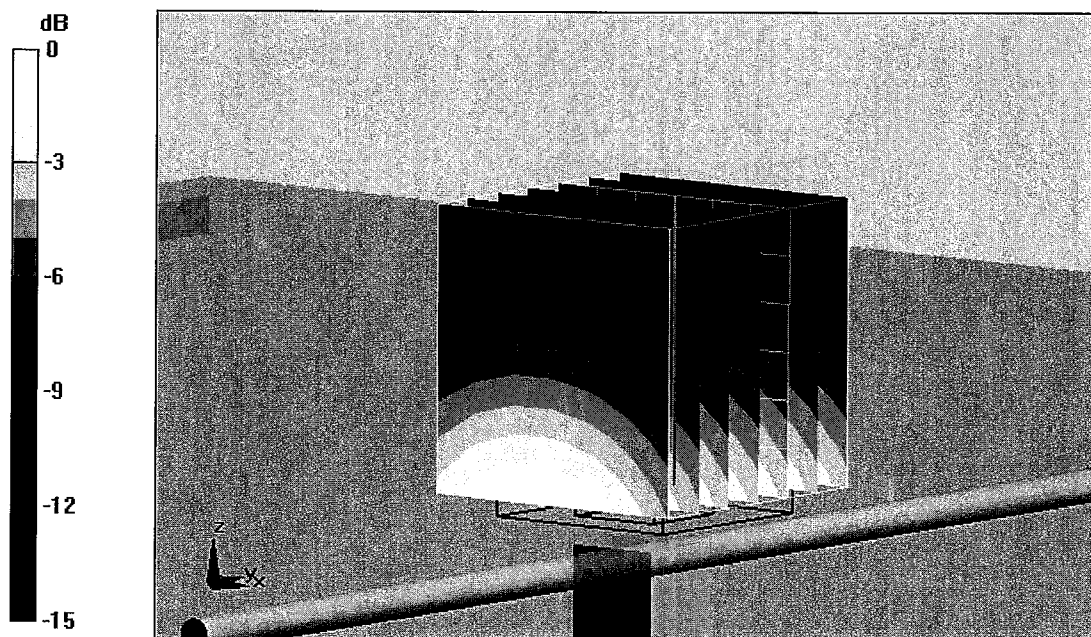

0 dB = 3.24mW/g

Impedance Measurement Plot for Body TSL

17 Aug 2009 08:58:55

CH1 S11 1 U FS 2: 45.471 Ω -11.215 Ω 15.768 pF 900.000 000 MHz

*
De1
Cor
Avg
16

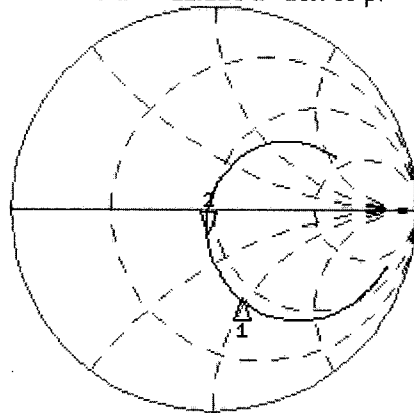

CH1 Markers
1: 41.352 Ω
-46.816 Ω
835.000 MHz

CH2 S11 LOG 5 dB/REF -20 dB 2: -18.006 dB 900.000 000 MHz

Cor
Avg
16

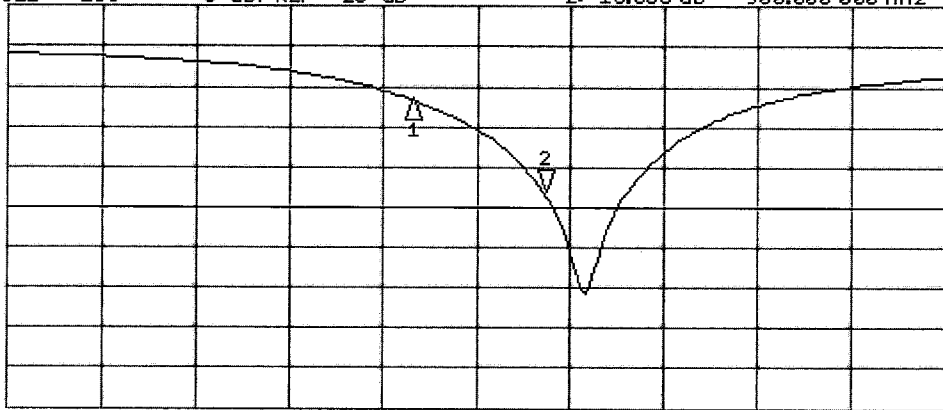

CH2 Markers
1: -6.6738 dB
835.000 MHz

START 635.000 000 MHz

STOP 1 100.000 000 MHz



Accredited by the Swiss Accreditation Service (SAS) Accreditation No.: **SCS 108**

The Swiss Accreditation Service is one of the signatories to the EA
Multilateral Agreement for the recognition of calibration certificates

RFI Asset: A1378

Client **RFI**

Certificate No: **EX3-3508_Jul10**

CALIBRATION CERTIFICATE

Object: **EX3DV3 - SN:3508**

Calibration procedure(s): **QA CAL-01.v6, QA CAL-12.v6, QA CAL-23.v3 and QA CAL-25.v2
Calibration procedure for dosimetric E-field probes**

Calibration date: **July 15, 2010 (Additional Conversion Factors)**

This calibration certificate documents the traceability to national standards, which realize the physical units of measurements (SI).
The measurements and the uncertainties with confidence probability are given on the following pages and are part of the certificate.

All calibrations have been conducted in the closed laboratory facility: environment temperature (22 ± 3)°C and humidity < 70%.

Calibration Equipment used (M&TE critical for calibration)

Primary Standards	ID #	Cal Date (Certificate No.)	Scheduled Calibration
Power meter E4419B	GB41293874	1-Apr-10 (No. 217-01136)	Apr-11
Power sensor E4412A	MY41495277	1-Apr-10 (No. 217-01136)	Apr-11
Power sensor E4412A	MY41498087	1-Apr-10 (No. 217-01136)	Apr-11
Reference 3 dB Attenuator	SN: S5054 (3c)	30-Mar-10 (No. 217-01159)	Mar-11
Reference 20 dB Attenuator	SN: S5086 (20b)	30-Mar-10 (No. 217-01161)	Mar-11
Reference 30 dB Attenuator	SN: S5129 (30b)	30-Mar-10 (No. 217-01160)	Mar-11
Reference Probe ES3DV2	SN: 3013	30-Dec-09 (No. ES3-3013_Dec09)	Dec-10
DAE4	SN: 660	20-Apr-10 (No. DAE4-660_Apr10)	Apr-11
Secondary Standards	ID #	Check Date (in house)	Scheduled Check
RF generator HP 8648C	US3642U01700	4-Aug-99 (in house check Oct-09)	In house check: Oct-11
Network Analyzer HP 8753E	US37390585	18-Oct-01 (in house check Oct-09)	In house check: Oct10

Calibrated by:	Name Jeton Kastrati	Function Laboratory Technician	Signature
Approved by:	Name Katja Pokovic	Function Technical Manager	Signature

Issued: July 15, 2010

This calibration certificate shall not be reproduced except in full without written approval of the laboratory.



Accredited by the Swiss Accreditation Service (SAS)

Accreditation No.: **SCS 108**

The Swiss Accreditation Service is one of the signatories to the EA
Multilateral Agreement for the recognition of calibration certificates

Glossary:

TSL	tissue simulating liquid
NORM _{x,y,z}	sensitivity in free space
ConvF	sensitivity in TSL / NORM _{x,y,z}
DCP	diode compression point
CF	crest factor (1/duty_cycle) of the RF signal
A, B, C	modulation dependent linearization parameters
Polarization φ	φ rotation around probe axis
Polarization ϑ	ϑ rotation around an axis that is in the plane normal to probe axis (at measurement center), i.e., $\vartheta = 0$ is normal to probe axis

Calibration is Performed According to the Following Standards:

- IEEE Std 1528-2003, "IEEE Recommended Practice for Determining the Peak Spatial-Averaged Specific Absorption Rate (SAR) in the Human Head from Wireless Communications Devices: Measurement Techniques", December 2003
- IEC 62209-1, "Procedure to measure the Specific Absorption Rate (SAR) for hand-held devices used in close proximity to the ear (frequency range of 300 MHz to 3 GHz)", February 2005

Methods Applied and Interpretation of Parameters:

- NORM_{x,y,z}**: Assessed for E-field polarization $\vartheta = 0$ ($f \leq 900$ MHz in TEM-cell; $f > 1800$ MHz: R22 waveguide). NORM_{x,y,z} are only intermediate values, i.e., the uncertainties of NORM_{x,y,z} does not effect the E²-field uncertainty inside TSL (see below *ConvF*).
- NORM(f)_{x,y,z}** = NORM_{x,y,z} * *frequency_response* (see Frequency Response Chart). This linearization is implemented in DASY4 software versions later than 4.2. The uncertainty of the frequency response is included in the stated uncertainty of *ConvF*.
- DCP_{x,y,z}**: DCP are numerical linearization parameters assessed based on the data of power sweep with CW signal (no uncertainty required). DCP does not depend on frequency nor media.
- A_{x,y,z}; B_{x,y,z}; C_{x,y,z}; VR_{x,y,z}**: A, B, C are numerical linearization parameters assessed based on the data of power sweep for specific modulation signal. The parameters do not depend on frequency nor media. VR is the maximum calibration range expressed in RMS voltage across the diode.
- ConvF and Boundary Effect Parameters**: Assessed in flat phantom using E-field (or Temperature Transfer Standard for $f \leq 800$ MHz) and inside waveguide using analytical field distributions based on power measurements for $f > 800$ MHz. The same setups are used for assessment of the parameters applied for boundary compensation (alpha, depth) of which typical uncertainty values are given. These parameters are used in DASY4 software to improve probe accuracy close to the boundary. The sensitivity in TSL corresponds to NORM_{x,y,z} * *ConvF* whereby the uncertainty corresponds to that given for *ConvF*. A frequency dependent *ConvF* is used in DASY version 4.4 and higher which allows extending the validity from ± 50 MHz to ± 100 MHz.
- Spherical isotropy (3D deviation from isotropy)**: in a field of low gradients realized using a flat phantom exposed by a patch antenna.
- Sensor Offset**: The sensor offset corresponds to the offset of virtual measurement center from the probe tip (on probe axis). No tolerance required.

Probe EX3DV3

SN:3508

Additional Conversion Factors

Manufactured:	December 19, 2003
Last calibrated:	February 19, 2010
Recalibrated:	July 15, 2010

Calibrated for DASY/EASY Systems

(Note: non-compatible with DASY2 system!)

DASY/EASY - Parameters of Probe: EX3DV3 SN:3508**Basic Calibration Parameters**

	Sensor X	Sensor Y	Sensor Z	Unc (k=2)
Norm ($\mu\text{V}/(\text{V}/\text{m})^2$) ^A	0.77	0.63	0.65	$\pm 10.1\%$
DCP (mV) ^B	99.8	95.0	92.6	

Modulation Calibration Parameters

UID	Communication System Name	PAR		A dB	B dBuV	C	VR mV	Unc ^E (k=2)
10000	CW	0.00	X	0.00	0.00	1.00	300	$\pm 1.5\%$
			Y	0.00	0.00	1.00	300	
			Z	0.00	0.00	1.00	300	

The reported uncertainty of measurement is stated as the standard uncertainty of measurement multiplied by the coverage factor k=2, which for a normal distribution corresponds to a coverage probability of approximately 95%.

^A The uncertainties of NormX,Y,Z do not affect the E²-field uncertainty inside TSL (see Pages 5 and 6).

^B Numerical linearization parameter: uncertainty not required.

^E Uncertainty is determined using the maximum deviation from linear response applying recatangular distribution and is expressed for the square of the field value.

DASY/EASY - Parameters of Probe: EX3DV3 SN:3508

Calibration Parameter Determined in Head Tissue Simulating Media

f [MHz]	Validity [MHz] ^c	Permittivity	Conductivity	ConvF X	ConvF Y	ConvF Z	Alpha	Depth Unc (k=2)
450	± 50 / ± 100	43.5 ± 5%	0.87 ± 5%	10.81	10.81	10.81	0.11	1.00 ± 13.3%
750	± 50 / ± 100	41.9 ± 5%	0.89 ± 5%	10.80	10.80	10.80	0.38	0.75 ± 11.0%
900	± 50 / ± 100	41.5 ± 5%	0.97 ± 5%	10.08	10.08	10.08	0.38	0.77 ± 11.0%
1750	± 50 / ± 100	40.1 ± 5%	1.37 ± 5%	9.09	9.09	9.09	0.52	0.63 ± 11.0%
1900	± 50 / ± 100	40.0 ± 5%	1.40 ± 5%	8.75	8.75	8.75	0.35	0.76 ± 11.0%
2450	± 50 / ± 100	39.2 ± 5%	1.80 ± 5%	7.95	7.95	7.95	0.31	0.80 ± 11.0%

^c The validity of ± 100 MHz only applies for DASY v4.4 and higher (see Page 2). The uncertainty is the RSS of the ConvF uncertainty at calibration frequency and the uncertainty for the indicated frequency band.

DASY/EASY - Parameters of Probe: EX3DV3 SN:3508

Calibration Parameter Determined in Body Tissue Simulating Media

f [MHz]	Validity [MHz] ^c	Permittivity	Conductivity	ConvF X	ConvF Y	ConvF Z	Alpha	Depth Unc (k=2)
450	± 50 / ± 100	56.7 ± 5%	0.94 ± 5%	11.71	11.71	11.71	0.02	1.00 ± 13.3%
900	± 50 / ± 100	55.0 ± 5%	1.05 ± 5%	10.45	10.45	10.45	0.50	0.74 ± 11.0%
1750	± 50 / ± 100	53.4 ± 5%	1.49 ± 5%	8.79	8.79	8.79	0.39	0.77 ± 11.0%
1900	± 50 / ± 100	53.3 ± 5%	1.52 ± 5%	8.45	8.45	8.45	0.36	0.80 ± 11.0%
2150	± 50 / ± 100	53.0 ± 5%	1.75 ± 5%	8.50	8.50	8.50	0.22	1.14 ± 11.0%
2450	± 50 / ± 100	52.7 ± 5%	1.95 ± 5%	8.19	8.19	8.19	0.34	0.80 ± 11.0%

^c The validity of ± 100 MHz only applies for DASY v4.4 and higher (see Page 2). The uncertainty is the RSS of the ConvF uncertainty at calibration frequency and the uncertainty for the indicated frequency band.

Conversion Factor Assessment

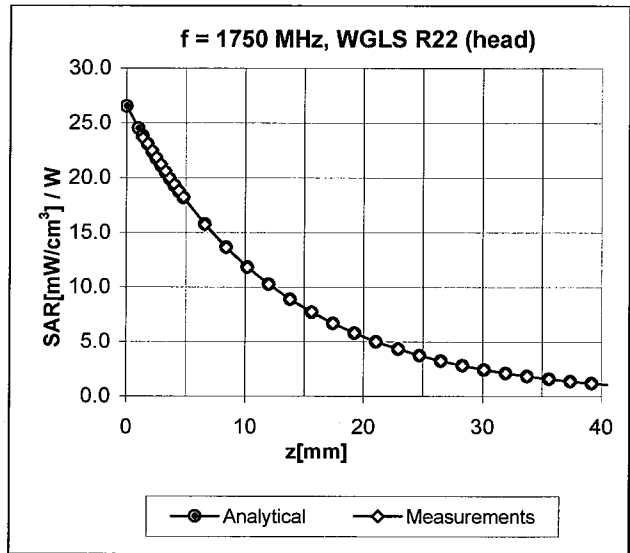
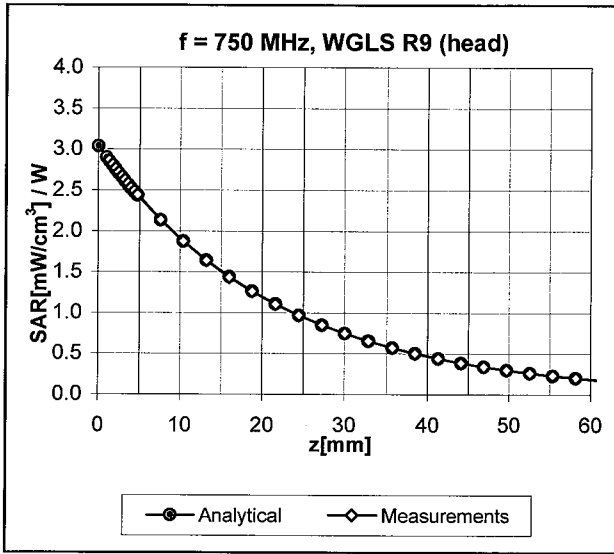

Deviation from Isotropy in HSL

Error (ϕ , θ), f = 900 MHz

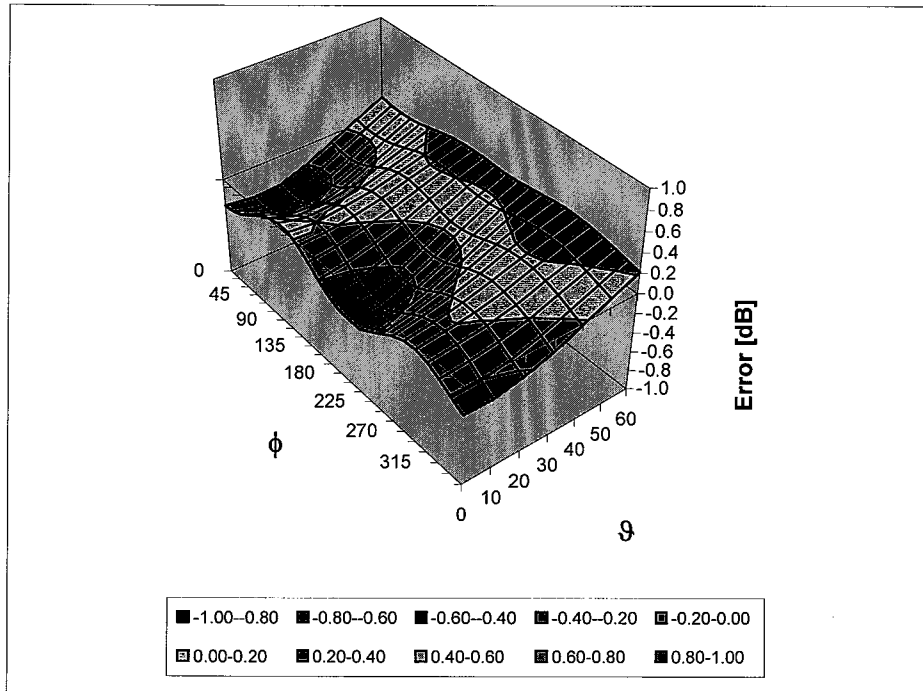

Uncertainty of Spherical Isotropy Assessment: $\pm 2.6\%$ (k=2)

Other Probe Parameters

Sensor Arrangement	Triangular
Connector Angle (°)	Not applicable
Mechanical Surface Detection Mode	enabled
Optical Surface Detection Mode	disabled
Probe Overall Length	337 mm
Probe Body Diameter	10 mm
Tip Length	9 mm
Tip Diameter	2.5 mm
Probe Tip to Sensor X Calibration Point	1 mm
Probe Tip to Sensor Y Calibration Point	1 mm
Probe Tip to Sensor Z Calibration Point	1 mm
Recommended Measurement Distance from Surface	2 mm

Test of: NTT docomo P-02C

To: OET Bulletin 65 Supplement C: (2001-01)

Appendix 2. Measurement Methods

A.2.1. Evaluation Procedure

The Specific Absorption Rate (SAR) evaluation was performed in the following manner:

- a) (i) The evaluation was performed in an applicable area of the phantom depending on the type of device being tested. For devices worn about the ear during normal operation, both the left and right ear positions were evaluated at the centre frequency of the band at maximum power. The side, which produced the greatest SAR, determined which side of the phantom would be used for the entire evaluation. The positioning of the head worn device relative to the phantom was dictated by the test specification identified in section 3.1 of this report.

(ii) For body worn devices or devices which can be operated within 20 cm of the body, the flat section of the SAM phantom was used were the size of the device(s) is normal. for bigger devices and base station the 2mm Oval phantom is used for evaluation. The type of device being evaluated dictated the distance of the EUT to the outer surface of the phantom flat section.
 - b) The SAR was determined by a pre-defined procedure within the DASY4 software. The exposed region of the phantom was scanned near the inner surface with a grid spacing of 20mm x 20mm or appropriate resolution.
 - c) A 5x5x7 matrix was performed around the greatest spatial SAR distribution found during the area scan of the applicable exposed region. SAR values were then calculated using a 3-D spline interpolation algorithm and averaged over spatial volumes of 1 and 10 grams.
 - d) If the EUT had any appreciable drift over the course of the evaluation, then the EUT was re-evaluated. Any unusual anomalies over the course of the test also warranted a re-evaluation.
-

Test of: NTT docomo P-02C

To: OET Bulletin 65 Supplement C: (2001-01)

A.2.2. Specific Absorption Rate (SAR) Measurements to OET Bulletin 65 Supplement C: (2001-01)

Evaluating Compliance with FCC Guidelines for Human Exposure to Radio Frequency Electromagnetic Fields

SAR measurements were performed in accordance with Appendix D of the standard FCC OET Bulletin 65 Supplement C: 2001, against appropriate limits for each measurement position in accordance with the standard.

The test was performed in a shielded enclosure with the temperature controlled to remain between +18.0°C and +25.0°C. The tissue equivalent material fluid temperature was controlled to give a maximum variation of $\pm 2.0^\circ\text{C}$

Prior to any SAR measurements on the EUT, system validation and material dielectric property measurements were conducted. In the absence of a detailed procedure within the specification, system validation and material dielectric property measurements were performed in accordance with Appendix C and Appendix D of FCC OET Bulletin 65 Supplement C: 2001.

Following the successful system validation and material dielectric property measurements, a SAR versus time sweep shall be performed within 10 mm of the phantom inner surface. If the EUT power output is stable after three minutes then the measurement probe will perform a coarse surface level scan at each test position in order to ascertain the location of the maximum local SAR level. Once this area had been established, a 5x5x7 cube of 343 points (5 mm spacing in each axis $\approx 27\text{g}$) will be centred at the area of concern. Extrapolation and interpolation will then be carried out on the 27g of tissue and the highest averaged SAR over a 10g cube determined.

Once the maximum interpolated SAR measurement is complete; the coarse scan is visually assessed to check for secondary peaks within 50% of the maximum SAR level. If there are any further SAR measurements required, extra 5x5x7 cubes shall be centred on each of these extra local SAR maxima.

At the end of each position test case a second time sweep shall be performed to check whether the EUT has remained stable throughout the test.

Test of: NTT docomo P-02C

To: OET Bulletin 65 Supplement C: (2001-01)

Appendix 3. SAR Distribution Scans

This appendix contains SAR distribution scans which are included in the total number of pages for this report.

Scan Reference Number	Title
SCN/78769JD09/001	Touch Left FDD V CH4183
SCN/78769JD09/002	Tilt Left FDD V CH4183
SCN/78769JD09/003	Touch Right on Phantom Flat Section FDD V CH4183
SCN/78769JD09/004	Tilt Right on Phantom Flat Section FDD V CH4183
SCN/78769JD09/005	Front of EUT Facing Phantom FDD V CH4183
SCN/78769JD09/006	Rear of EUT Facing Phantom FDD V CH4183
SCN/78769JD09/007	Rear of EUT Facing Phantom With PHF FDD V CH4183
SCN/78769JD09/008	Rear of EUT Facing Phantom FDD V + HSDPA CH4183
SCN/78769JD09/009	System Performance Check 900MHz Body 27 08 10

Explanation for conversion factor at GSM850 MHz Head

The SAR probe for the DASY v4.4 and higher has a validity of +/- 100 MHz from the spot frequency that the system is calibrated at. The version of DASY system used by RFI is v4.7 which is cover by the calibration range of +/- 100 MHz.

The SAR probe was calibrated at 750 MHz (covering 650 MHz to 850 MHz) and 900 MHz (covering 800 MHz to 1000 MHz) for the Head tissue with both the 750 MHz and 900 MHz calibration parameters imported on the same data file of the DASY4 system. For GSM850 (head SAR test) the DASY4 v4.7 system uses the conversion factor for 750 MHz calibration as this covers the frequency range of 650 MHz to 850 MHz. The SAR system uses the 900 MHz conversion factor which is valid from 800 MHz to 1000 MHz for the system validation performed at 900 MHz. The 900 MHz validation is adequate for the 850 band as this is within 50 MHz of the of the centre frequency.

Test of: NTT docomo P-02C

To: OET Bulletin 65 Supplement C: (2001-01)

SCN/78769JD09/001: Touch Left FDD V CH4183

Date: 27/08/2010

DUT: Panasonic P-02C; Type: P-02C (Sample C4); Serial: 352172040013568

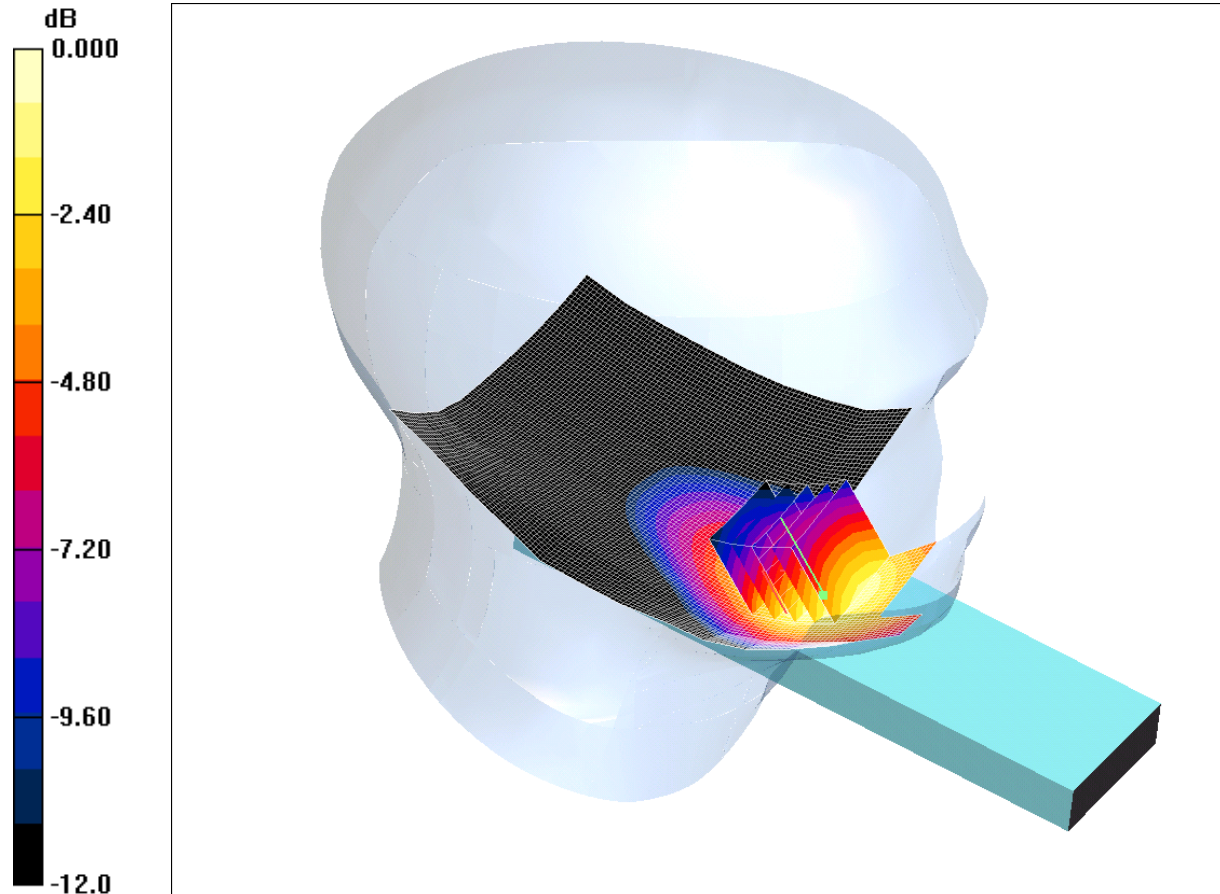

0 dB = 0.415mW/g

Communication System: UMTS-FDD V; Frequency: 836.6 MHz; Duty Cycle: 1:1

Medium: 900 MHz HSL Medium parameters used (interpolated): $f = 836.6$ MHz; $\sigma = 0.903$ mho/m; $\epsilon_r = 41.7$; $\rho = 1000$ kg/m³

Phantom section: Left Section

DASY4 Configuration:

- Probe: EX3DV3 - SN3508 (Add. ConvF); ConvF(10.8, 10.8, 10.8); Calibrated: 15/07/2010
- Sensor-Surface: 4mm (Mechanical Surface Detection)
- Electronics: DAE3 Sn394; Calibrated: 19/04/2010
- Phantom: SAM 12a; Type: SAM 4.0; Serial: TP:1193
- Measurement SW: DASY4, V4.7 Build 55; Postprocessing SW: SEMCAD, V1.8 Build 176

Touch Left - Middle/Area Scan (81x171x1): Measurement grid: dx=15mm, dy=15mm

Maximum value of SAR (interpolated) = 0.432 mW/g

Touch Left - Middle/Zoom Scan (5x5x7) (5x5x7)/Cube 0: Measurement grid: dx=8mm, dy=8mm, dz=5mm

Reference Value = 2.87 V/m; Power Drift = -0.064 dB

Peak SAR (extrapolated) = 0.583 W/kg

SAR(1 g) = 0.388 mW/g; SAR(10 g) = 0.262 mW/g

Maximum value of SAR (measured) = 0.415 mW/g

Test of: NTT docomo P-02C

To: OET Bulletin 65 Supplement C: (2001-01)

SCN/78769JD09/002: Tilt Left FDD V CH4183

Date: 27/08/2010

DUT: Panasonic P-02C; Type: P-02C (Sample C4); Serial: 352172040013568

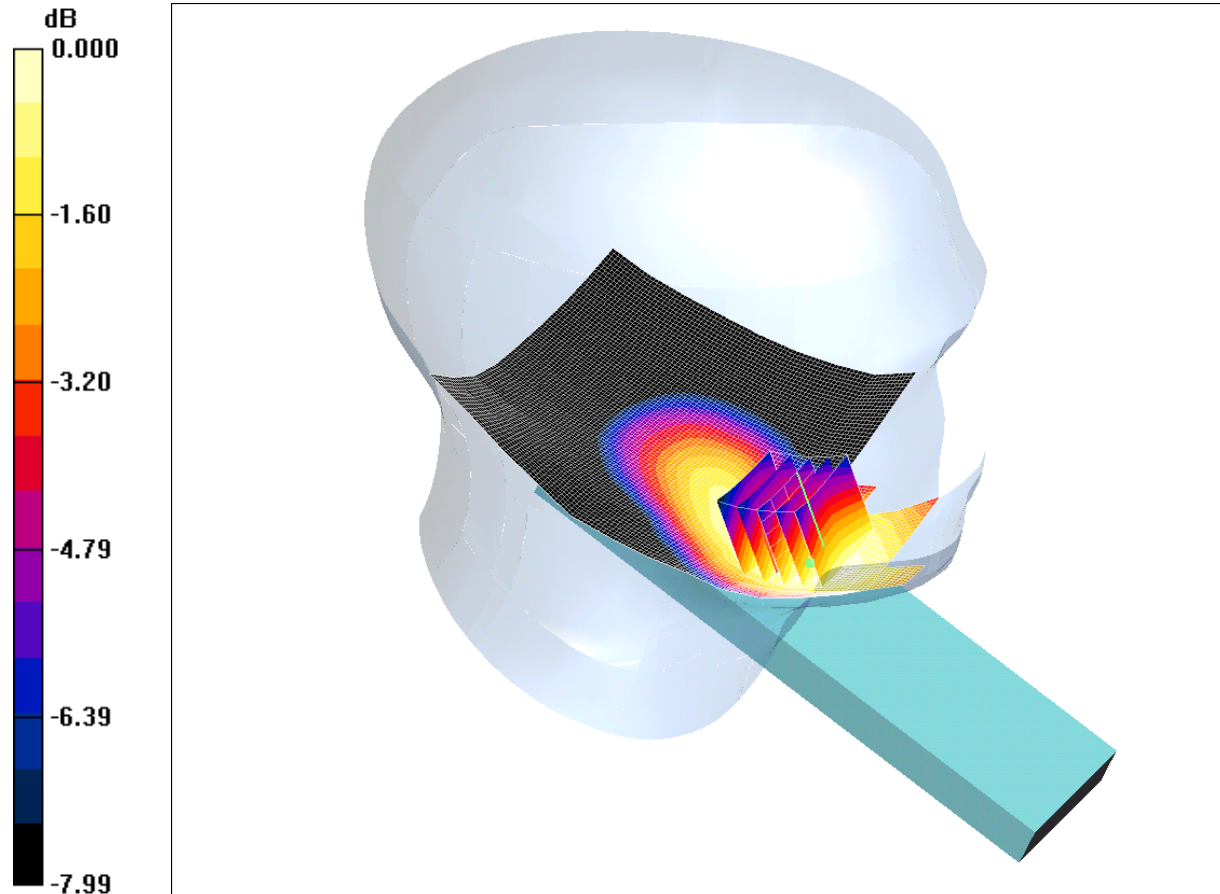

0 dB = 0.072mW/g

Communication System: UMTS-FDD V; Frequency: 836.6 MHz; Duty Cycle: 1:1

Medium: 900 MHz HSL Medium parameters used (interpolated): $f = 836.6$ MHz; $\sigma = 0.903$ mho/m; $\epsilon_r = 41.7$; $\rho = 1000$ kg/m³

Phantom section: Left Section

DASY4 Configuration:

- Probe: EX3DV3 - SN3508 (Add. ConvF); ConvF(10.8, 10.8, 10.8); Calibrated: 15/07/2010
- Sensor-Surface: 4mm (Mechanical Surface Detection)
- Electronics: DAE3 Sn394; Calibrated: 19/04/2010
- Phantom: SAM 12a; Type: SAM 4.0; Serial: TP:1193
- Measurement SW: DASY4, V4.7 Build 55; Postprocessing SW: SEMCAD, V1.8 Build 176

Tilt Left - Middle/Area Scan (81x171x1): Measurement grid: dx=15mm, dy=15mm

Maximum value of SAR (interpolated) = 0.075 mW/g

Tilt Left - Middle/Zoom Scan (5x5x7) (5x5x7)/Cube 0: Measurement grid: dx=8mm, dy=8mm, dz=5mm

Reference Value = 3.75 V/m; Power Drift = 0.285 dB

Peak SAR (extrapolated) = 0.087 W/kg

SAR(1 g) = 0.069 mW/g; SAR(10 g) = 0.055 mW/g

Maximum value of SAR (measured) = 0.072 mW/g

Test of: NTT docomo P-02C

To: OET Bulletin 65 Supplement C: (2001-01)

SCN/78769JD09/003: Touch Right on Phantom Flat Section FDD V CH4183

Date: 27/08/2010

DUT: Panasonic P-02C; Type: P-02C (Sample C4); Serial: 352172040013568

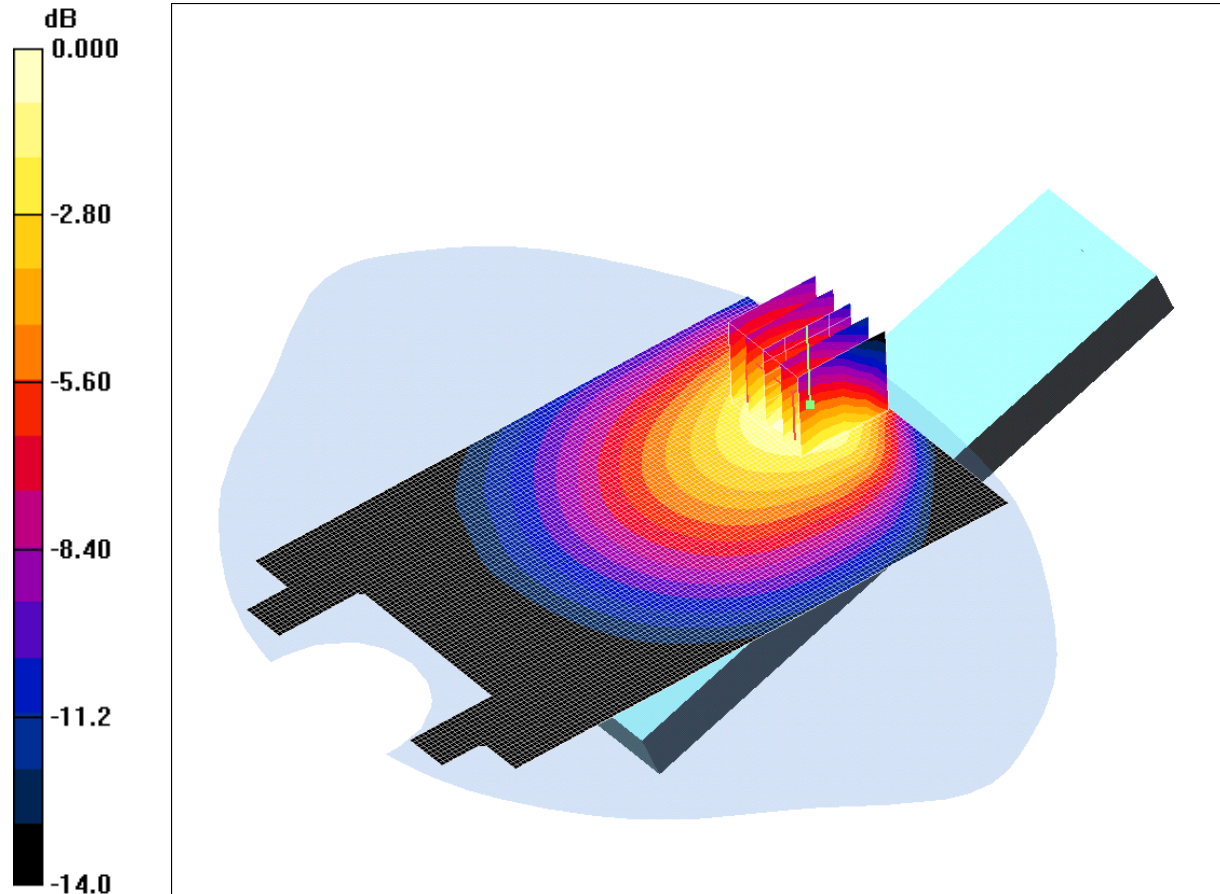

0 dB = 0.320mW/g

Communication System: UMTS-FDD V; Frequency: 836.6 MHz; Duty Cycle: 1:1

Medium: 900 MHz HSL Medium parameters used (interpolated): $f = 836.6$ MHz; $\sigma = 0.903$ mho/m; $\epsilon_r = 41.7$; $\rho = 1000$ kg/m³

Phantom section: Flat Section

DASY4 Configuration:

- Probe: EX3DV3 - SN3508 (Add. ConvF); ConvF(10.8, 10.8, 10.8); Calibrated: 15/07/2010
- Sensor-Surface: 4mm (Mechanical Surface Detection)
- Electronics: DAE3 Sn394; Calibrated: 19/04/2010
- Phantom: SAM 12a; Type: SAM 4.0; Serial: TP:1193
- Measurement SW: DASY4, V4.7 Build 55; Postprocessing SW: SEMCAD, V1.8 Build 176

Touch Right - Middle/Area Scan (81x171x1): Measurement grid: dx=15mm, dy=15mm

Maximum value of SAR (interpolated) = 0.329 mW/g

Touch Right - Middle/Zoom Scan (5x5x7) (5x5x7)/Cube 0: Measurement grid: dx=8mm, dy=8mm, dz=5mm

Reference Value = 7.28 V/m; Power Drift = 0.036 dB

Peak SAR (extrapolated) = 0.416 W/kg

SAR(1 g) = 0.301 mW/g; SAR(10 g) = 0.207 mW/g

Maximum value of SAR (measured) = 0.320 mW/g

Test of: NTT docomo P-02C

To: OET Bulletin 65 Supplement C: (2001-01)

SCN/78769JD09/004: Tilt Right on Phantom Flat Section FDD V CH4183

Date: 27/08/2010

DUT: Panasonic P-02C; Type: P-02C (Sample C4); Serial: 352172040013568

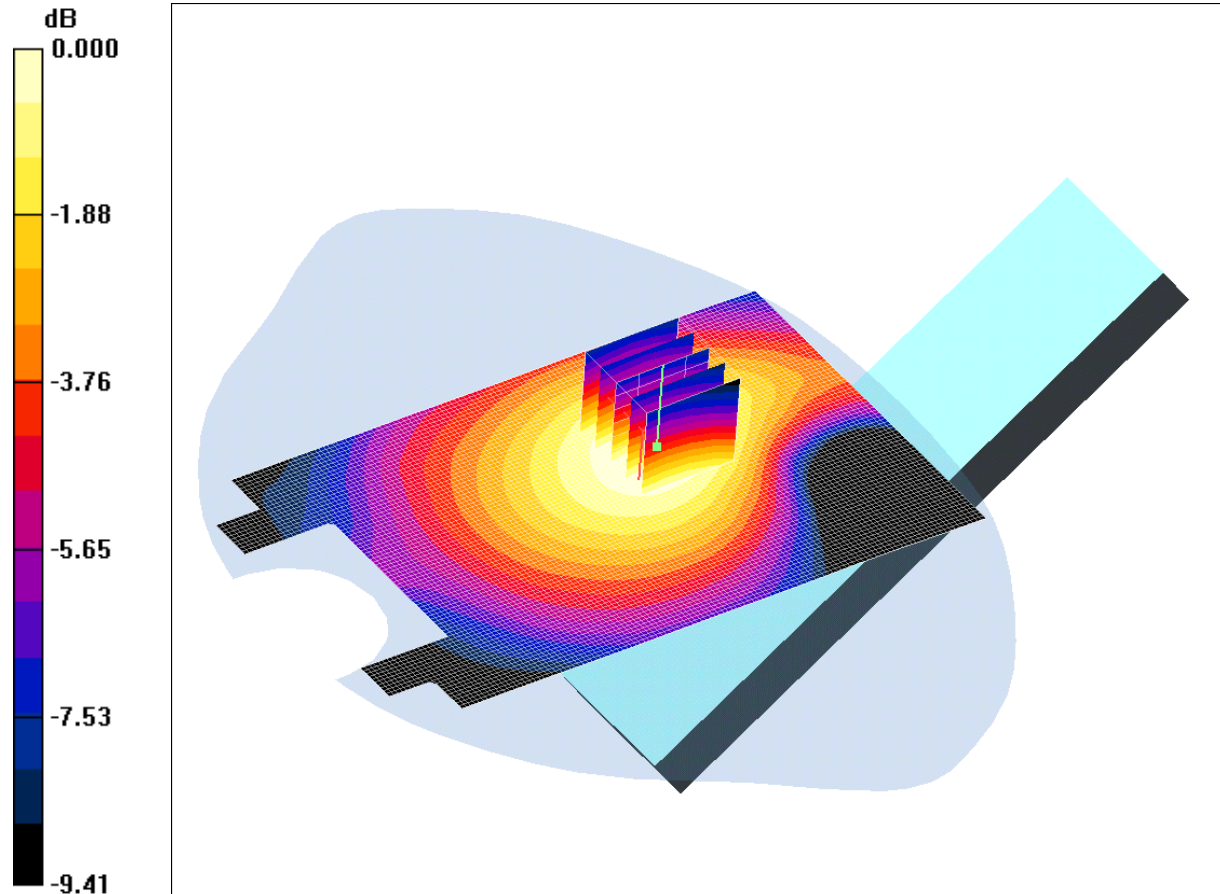

0 dB = 0.073mW/g

Communication System: UMTS-FDD V; Frequency: 836.6 MHz; Duty Cycle: 1:1

Medium: 900 MHz HSL Medium parameters used (interpolated): $f = 836.6$ MHz; $\sigma = 0.903$ mho/m; $\epsilon_r = 41.7$; $\rho = 1000$ kg/m³

Phantom section: Flat Section

DASY4 Configuration:

- Probe: EX3DV3 - SN3508 (Add. ConvF); ConvF(10.8, 10.8, 10.8); Calibrated: 15/07/2010
- Sensor-Surface: 4mm (Mechanical Surface Detection)
- Electronics: DAE3 Sn394; Calibrated: 19/04/2010
- Phantom: SAM 12a; Type: SAM 4.0; Serial: TP:1193
- Measurement SW: DASY4, V4.7 Build 55; Postprocessing SW: SEMCAD, V1.8 Build 176

Tilt Right - Middle/Area Scan (81x171x1): Measurement grid: dx=15mm, dy=15mm

Maximum value of SAR (interpolated) = 0.074 mW/g

Tilt Right - Middle/Zoom Scan (5x5x7) (5x5x7)/Cube 0: Measurement grid: dx=8mm, dy=8mm, dz=5mm

Reference Value = 7.84 V/m; Power Drift = 0.019 dB

Peak SAR (extrapolated) = 0.091 W/kg

SAR(1 g) = 0.070 mW/g; SAR(10 g) = 0.051 mW/g

Maximum value of SAR (measured) = 0.073 mW/g

Test of: NTT docomo P-02C

To: OET Bulletin 65 Supplement C: (2001-01)

SCN/78769JD09/005: Front of EUT Facing Phantom FDD V CH4183

Date: 27/08/2010

DUT: Panasonic P-02C; Type: P-02C (Sample C4); Serial: 352172040013568

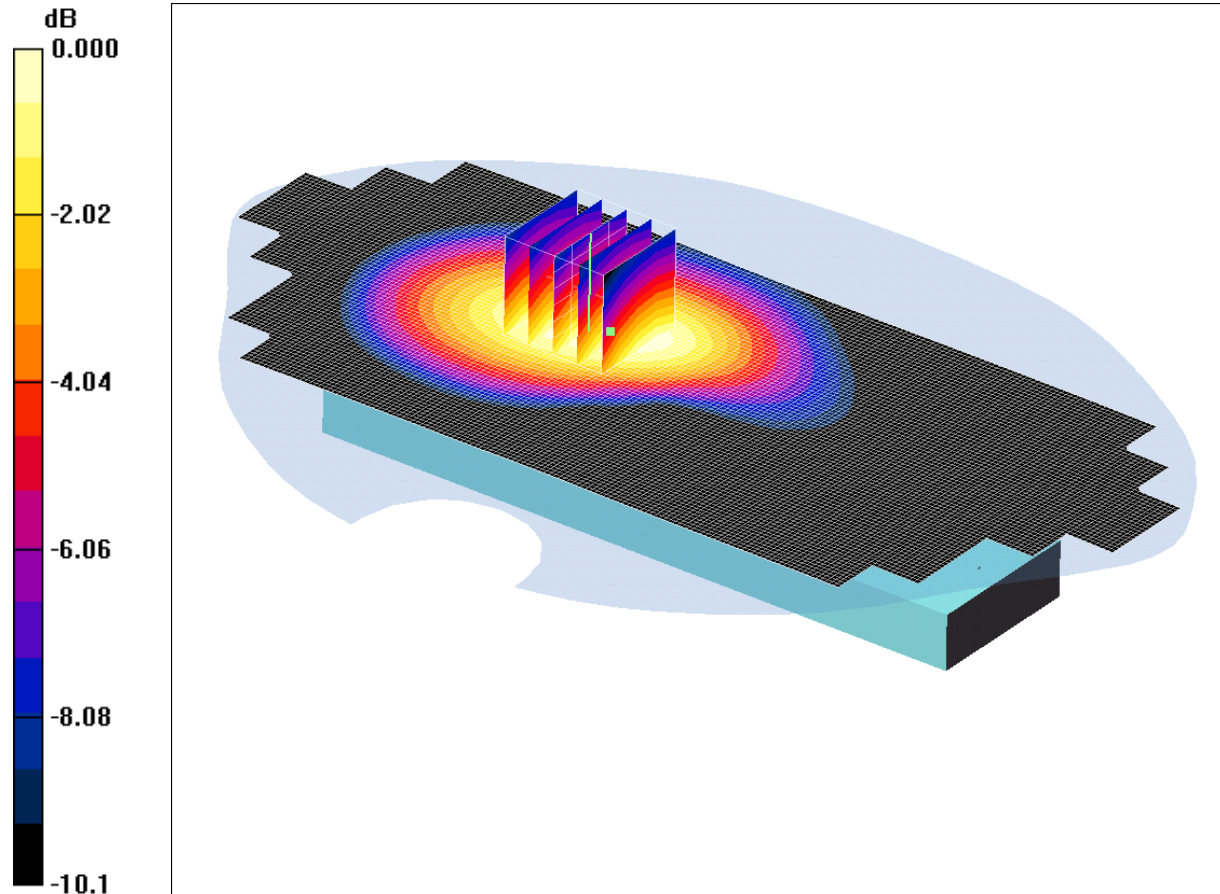

0 dB = 0.254mW/g

Communication System: UMTS-FDD V; Frequency: 836.6 MHz; Duty Cycle: 1:1

Medium: 900 MHz MSL Medium parameters used (interpolated): $f = 836.6$ MHz; $\sigma = 1.03$ mho/m; $\epsilon_r = 55.9$; $\rho = 1000$ kg/m³

Phantom section: Flat Section

DASY4 Configuration:

- Probe: EX3DV3 - SN3508 (Add. ConvF); ConvF(10.45, 10.45, 10.45); Calibrated: 15/07/2010
- Sensor-Surface: 4mm (Mechanical Surface Detection)
- Electronics: DAE3 Sn394; Calibrated: 19/04/2010
- Phantom: SAM 12b; Type: SAM 4.0; Serial: TP:1207
- Measurement SW: DASY4, V4.7 Build 55; Postprocessing SW: SEMCAD, V1.8 Build 176

Front of EUT Facing Phantom - Middle/Area Scan (81x191x1): Measurement grid: dx=15mm, dy=15mm

Maximum value of SAR (interpolated) = 0.258 mW/g

Front of EUT Facing Phantom - Middle/Zoom Scan (5x5x7) (5x5x7)/Cube 0: Measurement grid: dx=8mm, dy=8mm, dz=5mm

Reference Value = 9.49 V/m; Power Drift = -0.165 dB

Peak SAR (extrapolated) = 0.328 W/kg

SAR(1 g) = 0.243 mW/g; SAR(10 g) = 0.174 mW/g

Maximum value of SAR (measured) = 0.254 mW/g

Test of: NTT docomo P-02C

To: OET Bulletin 65 Supplement C: (2001-01)

SCN/78769JD09/006: Rear of EUT Facing Phantom FDD V CH4183

Date: 27/08/2010

DUT: Panasonic P-02C; Type: P-02C (Sample C4); Serial: 352172040013568

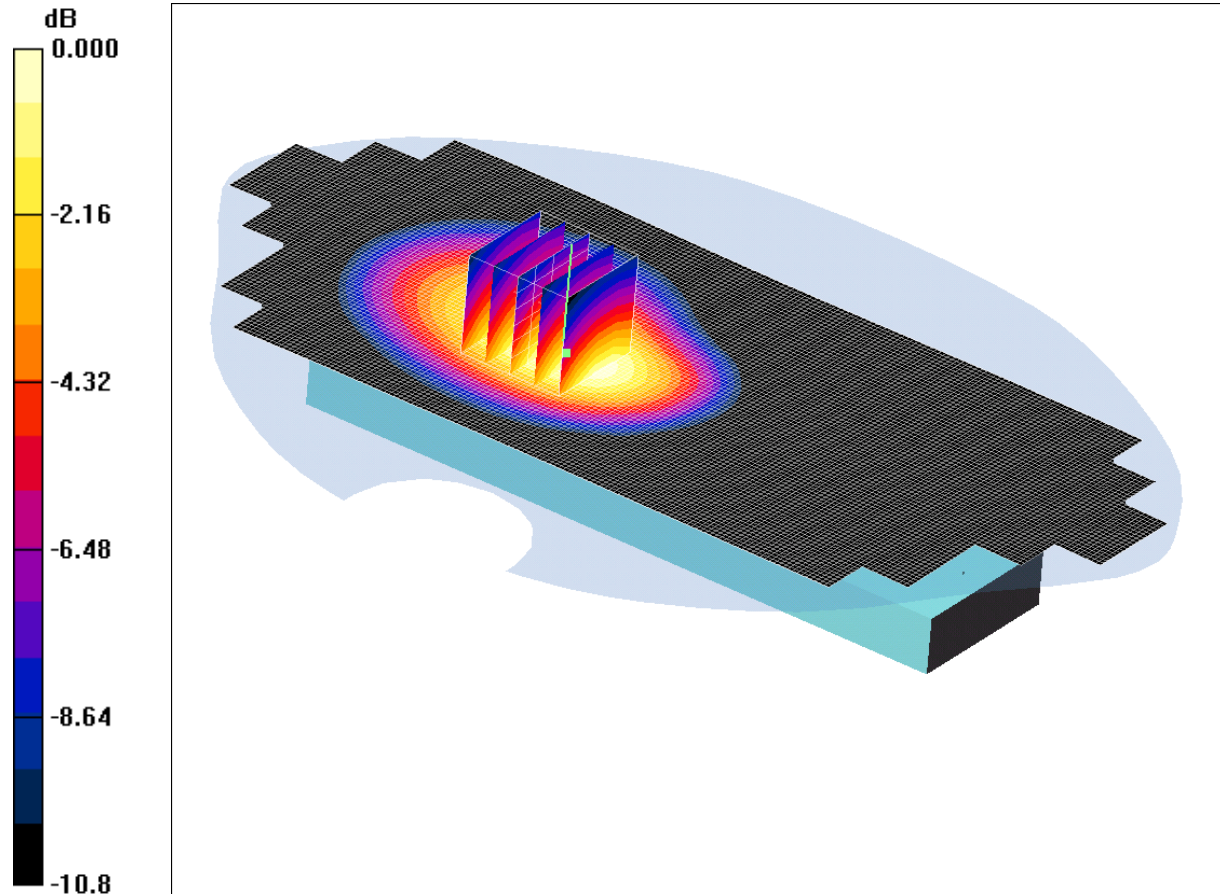

0 dB = 0.553mW/g

Communication System: UMTS-FDD V; Frequency: 836.6 MHz; Duty Cycle: 1:1

Medium: 900 MHz MSL Medium parameters used (interpolated): $f = 836.6$ MHz; $\sigma = 1.03$ mho/m; $\epsilon_r = 55.9$; $\rho = 1000$ kg/m³

Phantom section: Flat Section

DASY4 Configuration:

- Probe: EX3DV3 - SN3508 (Add. ConvF); ConvF(10.45, 10.45, 10.45); Calibrated: 15/07/2010
- Sensor-Surface: 4mm (Mechanical Surface Detection)
- Electronics: DAE3 Sn394; Calibrated: 19/04/2010
- Phantom: SAM 12b; Type: SAM 4.0; Serial: TP:1207
- Measurement SW: DASY4, V4.7 Build 55; Postprocessing SW: SEMCAD, V1.8 Build 176

Rear of EUT Facing Phantom - Middle/Area Scan (81x191x1): Measurement grid: dx=15mm, dy=15mm

Maximum value of SAR (interpolated) = 0.571 mW/g

Rear of EUT Facing Phantom - Middle/Zoom Scan (5x5x7) (5x5x7)/Cube 0: Measurement grid: dx=8mm, dy=8mm, dz=5mm

Reference Value = 16.5 V/m; Power Drift = 0.049 dB

Peak SAR (extrapolated) = 0.740 W/kg

SAR(1 g) = 0.529 mW/g; SAR(10 g) = 0.367 mW/g

Maximum value of SAR (measured) = 0.553 mW/g

Test of: NTT docomo P-02C

To: OET Bulletin 65 Supplement C: (2001-01)

SCN/78769JD09/007: Rear of EUT Facing Phantom With PHF FDD V CH4183

Date: 27/08/2010

DUT: Panasonic P-02C; Type: P-02C (Sample C4); Serial: 352172040013568

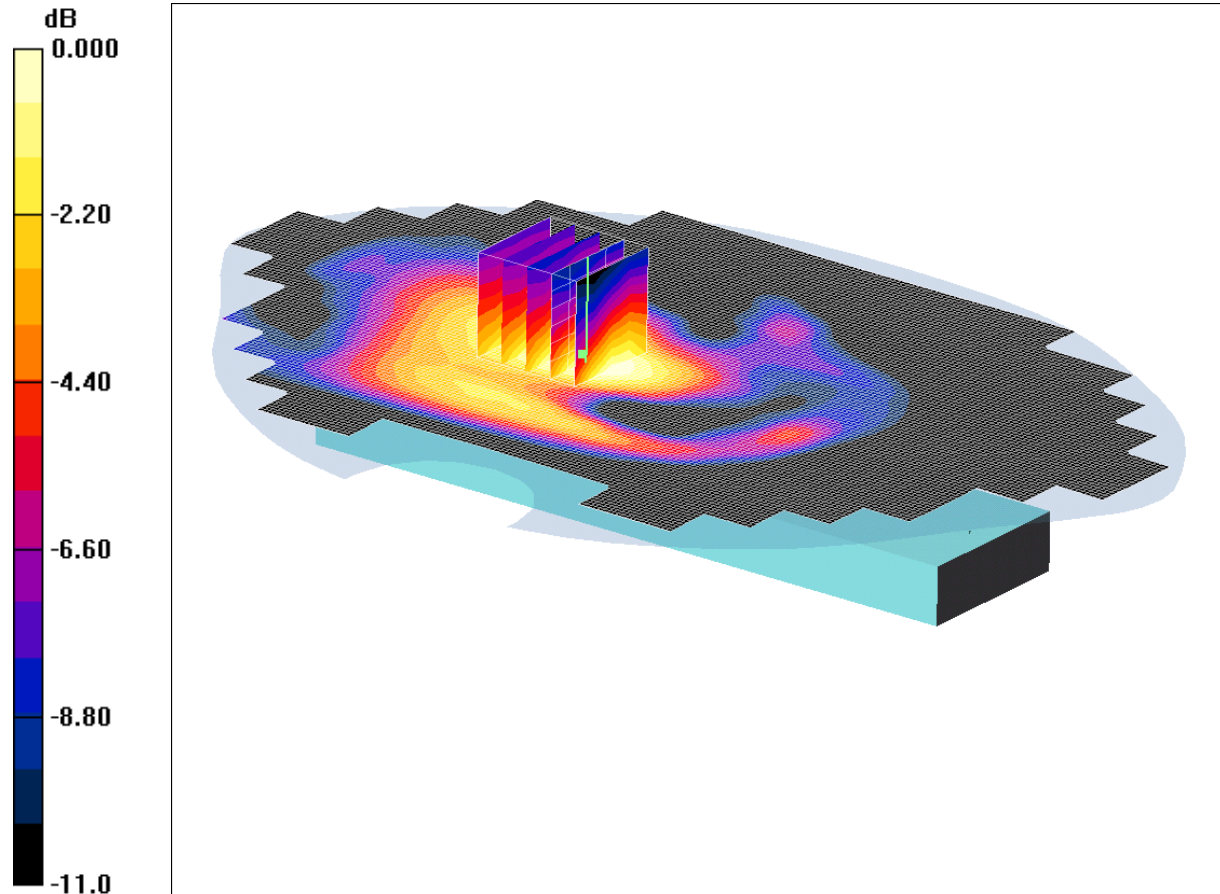

0 dB = 0.433mW/g

Communication System: UMTS-FDD V; Frequency: 836.6 MHz; Duty Cycle: 1:1

Medium: 900 MHz MSL Medium parameters used (interpolated): $f = 836.6$ MHz; $\sigma = 1.03$ mho/m; $\epsilon_r = 55.9$; $\rho = 1000$ kg/m³

Phantom section: Flat Section

DASY4 Configuration:

- Probe: EX3DV3 - SN3508 (Add. ConvF); ConvF(10.45, 10.45, 10.45); Calibrated: 15/07/2010
- Sensor-Surface: 4mm (Mechanical Surface Detection)
- Electronics: DAE3 Sn394; Calibrated: 19/04/2010
- Phantom: SAM 12b; Type: SAM 4.0; Serial: TP:1207
- Measurement SW: DASY4, V4.7 Build 55; Postprocessing SW: SEMCAD, V1.8 Build 176

Rear of EUT Facing Phantom With PHF - Middle 2/Area Scan (121x191x1): Measurement grid: dx=15mm, dy=15mm

Maximum value of SAR (interpolated) = 0.440 mW/g

Rear of EUT Facing Phantom With PHF - Middle 2/Zoom Scan (5x5x7) (5x5x7)/Cube 0: Measurement grid: dx=8mm, dy=8mm, dz=5mm

Reference Value = 16.4 V/m; Power Drift = -0.062 dB

Peak SAR (extrapolated) = 0.596 W/kg

SAR(1 g) = 0.412 mW/g; SAR(10 g) = 0.280 mW/g

Maximum value of SAR (measured) = 0.433 mW/g

Test of: NTT docomo P-02C

To: OET Bulletin 65 Supplement C: (2001-01)

SCN/78769JD09/008: Rear of EUT Facing Phantom FDD V + HSDPA CH4183

Date: 27/08/2010

DUT: Panasonic P-02C; Type: P-02C (Sample C4); Serial: 352172040013568

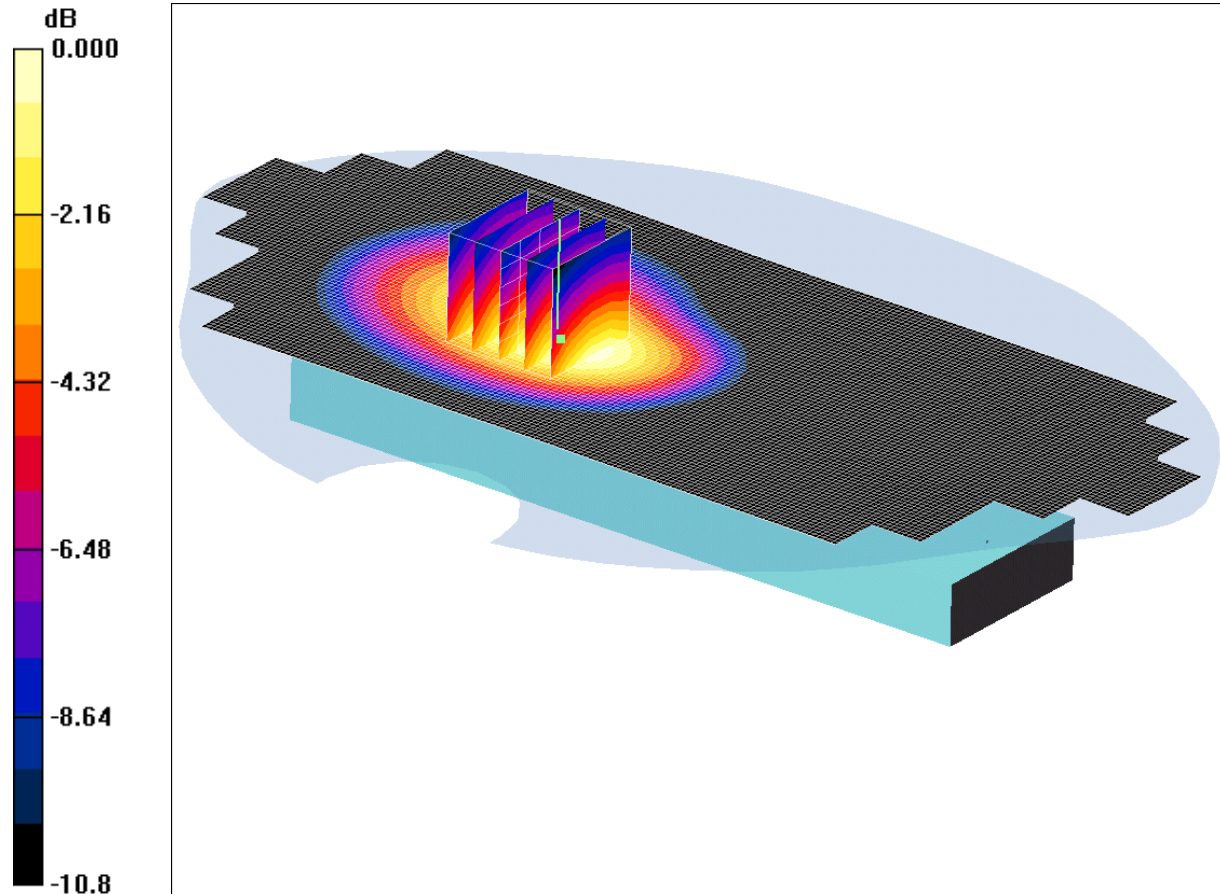

0 dB = 0.553mW/g

Communication System: UMTS-FDD V; Frequency: 836.6 MHz; Duty Cycle: 1:1

Medium: 900 MHz MSL Medium parameters used (interpolated): $f = 836.6$ MHz; $\sigma = 1.03$ mho/m; $\epsilon_r = 55.9$; $\rho = 1000$ kg/m³

Phantom section: Flat Section

DASY4 Configuration:

- Probe: EX3DV3 - SN3508 (Add. ConvF); ConvF(10.45, 10.45, 10.45); Calibrated: 15/07/2010
- Sensor-Surface: 4mm (Mechanical Surface Detection)
- Electronics: DAE3 Sn394; Calibrated: 19/04/2010
- Phantom: SAM 12b; Type: SAM 4.0; Serial: TP:1207
- Measurement SW: DASY4, V4.7 Build 55; Postprocessing SW: SEMCAD, V1.8 Build 176

Rear of EUT Facing Phantom - Middle/Area Scan (81x191x1): Measurement grid: dx=15mm, dy=15mm

Maximum value of SAR (interpolated) = 0.566 mW/g

Rear of EUT Facing Phantom - Middle/Zoom Scan (5x5x7) (5x5x7)/Cube 0: Measurement grid: dx=8mm, dy=8mm, dz=5mm

Reference Value = 16.5 V/m; Power Drift = 0.002 dB

Peak SAR (extrapolated) = 0.738 W/kg

SAR(1 g) = 0.528 mW/g; SAR(10 g) = 0.366 mW/g

Maximum value of SAR (measured) = 0.553 mW/g

Test of: NTT docomo P-02C

To: OET Bulletin 65 Supplement C: (2001-01)

SCN/78769JD09/009: System Performance Check 900MHz Body 27 08 10

Date: 27/08/2010

DUT: Dipole 900 MHz; Type: D900V2; Serial: SN185

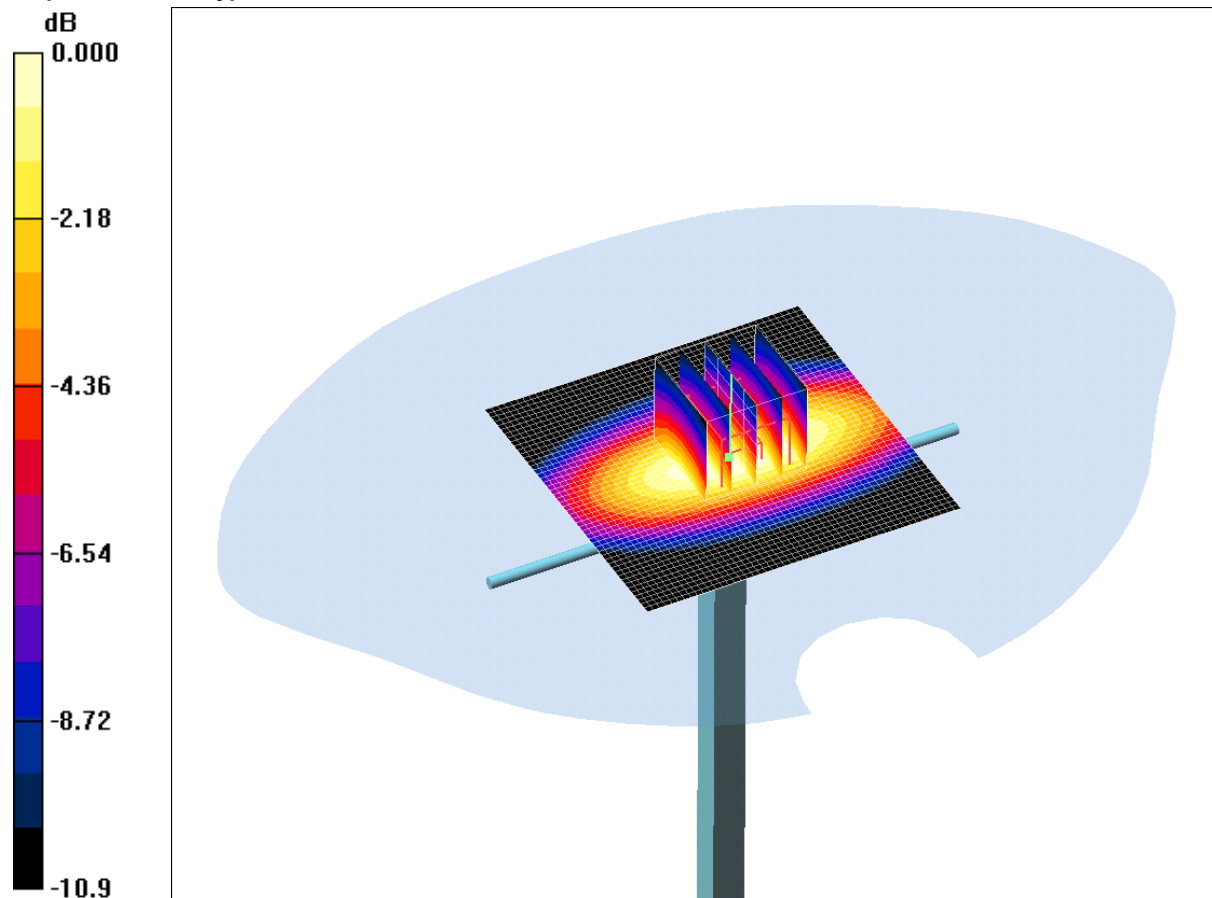

0 dB = 3.03mW/g

Communication System: CW; Frequency: 900 MHz; Duty Cycle: 1:1

Medium: 900 MHz MSL Medium parameters used: $f = 900$ MHz; $\sigma = 1.07$ mho/m; $\epsilon_r = 55.6$; $\rho = 1000$ kg/m³

Phantom section: Flat Section

DASY4 Configuration:

- Probe: EX3DV3 - SN3508 (Add. ConvF); ConvF(10.45, 10.45, 10.45); Calibrated: 15/07/2010
- Sensor-Surface: 4mm (Mechanical Surface Detection)
- Electronics: DAE3 Sn394; Calibrated: 19/04/2010
- Phantom: SAM 12b; Type: SAM 4.0; Serial: TP:1207
- Measurement SW: DASY4, V4.7 Build 55; Postprocessing SW: SEMCAD, V1.8 Build 176

d=15mm, Pin=250mW/Area Scan (51x51x1): Measurement grid: dx=20mm, dy=20mm

Maximum value of SAR (interpolated) = 3.19 mW/g

d=15mm, Pin=250mW/Zoom Scan (5x5x7) (5x5x7)/Cube 0: Measurement grid: dx=8mm, dy=8mm, dz=5mm

Reference Value = 52.8 V/m; Power Drift = 0.016 dB

Peak SAR (extrapolated) = 4.22 W/kg

SAR(1 g) = 2.8 mW/g; SAR(10 g) = 1.81 mW/g

Maximum value of SAR (measured) = 3.03 mW/g