



FCC PART 15C TEST REPORT FOR CERTIFICATION
On Behalf of

Altai Technologies Limited

Altai A8in (ac) Super WiFi Base Station

Model No.: WA8011NAC-H

FCC ID: UCC-WA8011NAC-H

Prepared for : Altai Technologies Limited
Units 209, 2/F, Lakeside 2.10 Science Park West Avenue, Hong
Kong Science Park, Shatin, Hong Kong, China

Prepared By : Audix Technology (Shenzhen) Co., Ltd.
No. 6, Ke Feng Rd., 52 Block,
Shenzhen Science & Industrial Park,
Nantou, Shenzhen, Guangdong, China

Tel: (0755) 26639496

Report Number : ACS-F16074
Date of Test : Jan.28~Mar.06, 2016
Date of Report : Apr.29, 2016

TABLE OF CONTENTS

Description	Page
1. SUMMARY OF STANDARDS AND RESULTS	1-1
1.1. Description of Standards and Results	1-1
2. GENERAL INFORMATION	2-1
2.1. Description of Device (EUT)	2-1
2.2. Test Information	2-2
2.3. Tested Supporting System Details	2-2
2.4. Block diagram of connection between the EUT and simulators	2-2
2.5. Test Facility	2-3
2.6. Measurement Uncertainty (95% confidence levels, k=2).....	2-3
3. POWER LINE CONDUCTED EMISSION TEST.....	3-1
3.1. Test Equipments	3-1
3.2. Block Diagram of Test Setup	3-1
3.3. Power Line Conducted Emission Test Limits	3-1
3.4. Configuration of EUT on Test.....	3-1
3.5. Operating Condition of EUT	3-2
3.6. Test Procedure	3-2
3.7. Power Line Conducted Emission Test Results	3-2
4. RADIATED EMISSION TEST	4-1
4.1. Test Equipment.....	4-1
4.2. Block Diagram of Test Setup	4-2
4.3. Radiated Emission Limit	4-3
4.4. EUT Configuration on Test	4-3
4.5. Operating Condition of EUT	4-4
4.6. Test Procedure	4-4
4.7. Radiated Emission Test Results	4-4
5. CONDUCTED SPURIOUS EMISSIONS	5-1
5.1. Test Equipment.....	5-1
5.2. Limit	5-1
5.3. Test Procedure	5-1
5.4. Test result	5-1
6. BAND EDGE COMPLIANCE TEST	6-1
6.1. Test Equipment.....	6-1
6.2. Limit	6-1
6.3. Test Produce	6-1
6.4. Test Results	6-1
7. 6dB Bandwidth Test	7-1
7.1. Test Equipment.....	7-1
7.2. Limit	7-1
7.3. Test Procedure	7-1
7.4. Test Results	7-1
8. OUTPUT POWER TEST	8-1
8.1. Test Equipment.....	8-1
8.2. Limit (FCC Part 15C 15.247 b (3))	8-1
8.3. Test Procedure	8-1
8.4. Test Results	8-2
9. POWER SPECTRAL DENSITY TEST	9-1
9.1. Test Equipment.....	9-1

9.2.	Limit	9-1
9.3.	Test Procedure	9-1
9.4.	Test Results	9-2
10.	MPE ESTIMATION	10-1
10.1.	Limit for General Population/ Uncontrolled Exposures	10-1
10.2.	Estimation Result.....	10-2
11.	ANTENNA REQUIREMENT	11-1
11.1.	Standard Applicable	11-1
11.2.	Antenna Connected Construction.....	11-1
12.	DEVIATION TO TEST SPECIFICATIONS	12-1
13.	PHOTOGRAPH OF TEST.....	13-1
13.1.	Photos of Power Line Conducted Emission Test	13-1
13.2.	Photos of Radiated Emission Test.....	13-2
14.	PHOTOS OF THE EUT	14-1

TEST REPORT CERTIFICATION

Applicant : Altai Technologies Limited
Manufacturer : Altai Technologies Limited
Product : Altai A8in (ac) Super WiFi Base Station
FCC ID : UCC-WA8011NAC-H
(A) Model No. : WA8011NAC-H
(B) Power Supply : DC 56V
(C) Test Voltage : DC 56V From POE Input AC 120V/60Hz

Tested for comply with:
FCC CFR 47 Part 15 Subpart C: 2014

Test procedure used:
ANSI C63.10: 2013

The device described above is tested by AUDIX TECHNOLOGY (SHENZHEN) CO., LTD. to confirm comply with all the FCC Part 15 Subpart C requirements. The test results are contained in this test report and AUDIX TECHNOLOGY (SHENZHEN) CO., LTD. is assumed full responsibility for the accuracy and completeness of these tests. Also, this report shows that the Equipment Under Test (EUT) is to be technically compliant with the FCC and IC requirements. This report contains data that are not covered by the NVLAP accreditation.

This Report is made under FCC Part 2.1075. No modifications were required during testing to bring this product into compliance.

This report applies to above tested sample only. This report shall not be reproduced in part without written approval of AUDIX TECHNOLOGY (SHENZHEN) CO., LTD.

The report must not be used by the client to claim product certification, approval, or endorsement by NVLAP, NIST, or any agency of the federal government.

Date of Test : Jan.28~Mar.06, 2016 Report of date: Apr.29, 2016

Prepared by : Kayli He Reviewed by : Sunny Lu
Kayli He / Assistant Sunny Lu / Assistant Manager



Approved & Authorized Signer : David Jin
David Jin / Manager

1. SUMMARY OF STANDARDS AND RESULTS

1.1. Description of Standards and Results

The EUT has been tested according to the applicable standards as referenced below.

EMISSION		
Description of Test Item	Standard	Results
Power Line Conducted Emission	FCC Part 15: 15.207	PASS
Radiated Emission	FCC Part 15: 15.209	PASS
Band Edge Compliance	FCC Part 15: 15.247	PASS
Conducted spurious emissions	FCC Part 15: 15.247	PASS
6dB Bandwidth	FCC Part 15: 15.247	PASS
Peak Output Power	FCC Part 15: 15.247	PASS
Power Spectral Density	FCC Part 15: 15.247	PASS
MPE Estimation	FCC Part 15: 15.247	PASS
Antenna requirement	FCC Part 15: 15.203	PASS

N/A is an abbreviation for Not Applicable.

2. GENERAL INFORMATION

2.1. Description of Device (EUT)

Product	: Altai A8in (ac) Super WiFi Base Station
Model No.	: WA8011NAC-H
FCC ID	: UCC-WA8011NAC-H
Operation Frequency	: IEEE 802.11a: 5745MHz—5825MHz IEEE 802.11b: 2412MHz—2462MHz IEEE 802.11g: 2412MHz—2462MHz IEEE 802.11n HT20: 2412MHz—2462MHz; 5745MHz—5825MHz IEEE 802.11n HT40: 2422MHz—2452MHz; 5755MHz—5795MHz IEEE 802.11ac VHT20: 5745MHz—5825MHz IEEE 802.11ac VHT40: 5755MHz—5795MHz IEEE 802.11ac VHT80: 5775MHz
Modulation Technology	: IEEE 802.11b: DSSS(CCK,DQPSK,DBPSK) IEEE 802.11a/g: OFDM(64QAM, 16QAM, QPSK, BPSK) IEEE 802.11ac VHT20, VHT40, VHT80: OFDM(16QAM, 64QAM, 256QAM, QPSK, BPSK) IEEE 802.11n HT20, HT40: OFDM (64QAM, 16QAM,QPSK,BPSK)
Antenna Assembly Gain	: Sector Antenna, 2.4GHz: 14dBi gain, Panel Antenna, 5GHz: 20dBi gain
Applicant	: Altai Technologies Limited Units 209, 2/F, Lakeside 2.10 Science Park West Avenue, Hong Kong Science Park, Shatin, Hong Kong, China
Manufacturer	: Altai Technologies Limited Units 209, 2/F, Lakeside 2.10 Science Park West Avenue, Hong Kong Science Park, Shatin, Hong Kong, China
POE	: Manufacturer: FSGREAT;M/N: GRT-560110A INPUT:AC 100-240V 50/60Hz OUTPUT:56V 1100mA
Date of Test	: Jan.28~Mar.06, 2016
Date of Receipt	: Jan.26, 2016
Sample Type	: Prototype production

2.2. Test Information

A special test software was used to control EUT work in Continuous TX mode(nearly 100% duty cycle), and select test channel, wireless mode and data rate.

Tested mode, channel, and data rate information			
Mode	data rate (Mbps)(see Note)	Channel	Frequency (MHz)
IEEE 802.11b	1	Low :CH1	2412
	1	Middle: CH6	2437
	1	High: CH11	2462
IEEE 802.11g	6	Low :CH1	2412
	6	Middle: CH6	2437
	6	High: CH11	2462
IEEE 802.11n HT20	MCS0	Low :CH1	2412
	MCS0	Middle: CH6	2437
	MCS0	High: CH11	2462
IEEE 802.11n HT40	MCS0	Low :CH3	2422
	MCS0	Middle: CH6	2437
	MCS0	High: CH9	2452

Note: 1. According exploratory test, EUT will have maximum output power in those data rate, so those data rate were used for all test.

Note: 2. This is 2T2R device use MIMO Technologies, test with two antennas transmit simultaneously, and comply with KDB662911D01 V02r01.

Note: 3. This device contains Four same 2.4GHz RF module, choose the module which has the MAX out power for the test.

2.3. Tested Supporting System Details

No.	Description	ACS No.	Manufacturer	Model	Serial Number
1	Notebook	N/A	DELL	PP09S	N/A
		Power Cord: Unshielded, Detachable, 1.8m Power Adapter: Manufacturer: DELL, M/N: LA65NS1-00 Cable: Unshielded, Detachable, 4.0m(Bond one ferrite core)			

2.4. Block diagram of connection between the EUT and simulators

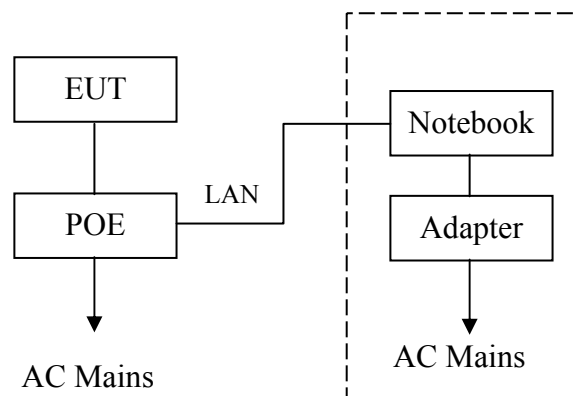

(EUT: Altai A8in (ac) Super WiFi Base Station)

2.5. Test Facility

Site Description

Name of Firm : Audix Technology (Shenzhen) Co., Ltd.
 No. 6, Ke Feng Rd., 52 Block, Shenzhen
 Science & Industrial Park, Nantou, Shenzhen,
 Guangdong, China

3m Anechoic Chamber : Certificated by FCC, USA
 Registration Number: 90454
 Valid Date: Dec.30, 2017

3m & 10m Anechoic Chamber : Certificated by FCC, USA
 Registration Number: 794232
 Valid Date: Jul.12, 2016

EMC Lab. : Certificated by Industry Canada
 Registration Number: IC 5183A-1
 Valid Date: May.14, 2017

: Certificated by DAkkS, Germany
 Registration No: D-PL-12151-01-00
 Valid Date: Dec.15, 2016

: Accredited by NVLAP, USA
 NVLAP Code: 200372-0
 Valid Date: Mar.31, 2017

2.6. Measurement Uncertainty (95% confidence levels, k=2)

Test Item	Uncertainty
Uncertainty for Conduction emission test in No. 1 Conduction	3.4dB (150kHz to 30MHz)
Uncertainty for Radiation Emission test in 3m chamber	2.6dB(30~200MHz, Polarization: H)
	2.6dB(30~200MHz, Polarization: V)
	3.0dB(200M~1GHz, Polarization: H)
	2.8dB(200M~1GHz, Polarization: V)
Uncertainty for Radiation Emission test in 3m chamber (1GHz-18GHz)	6.3dB (1~6GHz, Distance: 3m)
	5.7dB (6~18GHz, Distance: 3m)
Uncertainty for Radiated Spurious Emission test in RF chamber	3.6dB
Uncertainty for Conduction Spurious emission test	2.0dB
Uncertainty for Output power test	0.8dB
Uncertainty for Bandwidth test	83kHz
Uncertainty for DC power test	0.1%
Uncertainty for test site temperature and humidity	0.6°C
	3%

3. POWER LINE CONDUCTED EMISSION TEST

3.1. Test Equipments

Item	Equipment	Manufacturer	Model No.	Serial No.	Last Cal.	Cal. Interval
1.	1# Shielding Room	AUDIX	N/A	N/A	Apr.17,15	1 Year
2.	Test Receiver	Rohde & Schwarz	ESCI	100842	Apr.28,15	1 Year
3.	L.I.S.N.#1	Rohde & Schwarz	ESH2-Z5	100429	Oct.18,15	1 Year
4.	L.I.S.N.#2	Kyoritsu	K NW-403D	8-1750-2	Apr.28,15	1 Year
5.	Terminator	Hubersuhner	50Ω	No.1	Apr.28,15	1 Year
6.	Terminator	Hubersuhner	50Ω	No.2	Apr.28,15	1 Year
7.	RF Cable	MIYAZAKI	3D-2W	No.1	Apr.28,15	1 Year
8.	Coaxial Switch	Anritsu	MP59B	6200766906	Apr.28,15	1 Year
9.	Test Software	AUDIX	e3	6.100913a	N/A	N/A

3.2. Block Diagram of Test Setup

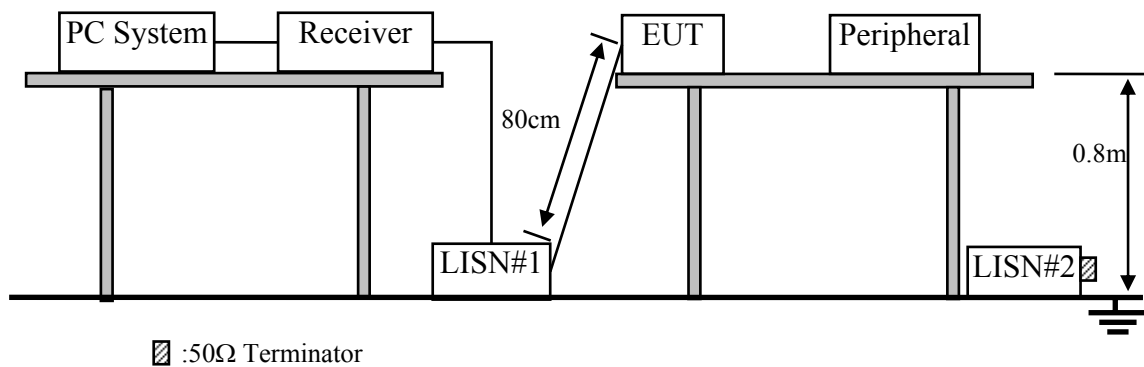

3.3. Power Line Conducted Emission Test Limits

Frequency	Maximum RF Line Voltage	
	Quasi-Peak Level dB(μV)	Average Level dB(μV)
150kHz ~ 500kHz	66 ~ 56*	56 ~ 46*
500kHz ~ 5MHz	56	46
5MHz ~ 30MHz	60	50

Notes: 1. * Decreasing linearly with logarithm of frequency.

2. The lower limit shall apply at the transition frequencies.

3.4. Configuration of EUT on Test

The following equipment are installed on Power Line Conducted Emission Test to meet the commission requirement and operating regulations in a manner which tends to maximize its emission characteristics in a normal application.

3.4.1. Altai A8in (ac) Super WiFi Base Station (EUT)

Model No. : WA8011NAC-H
Serial No. : N/A

3.4.2. Support Equipment: As Tested Supporting System Details, in Section 2.2.

3.5. Operating Condition of EUT

3.5.1. Setup the EUT and simulator as shown as Section 3.2.

3.5.2. Turn on the power of all equipments.

3.5.3. PC runs test software to control EUT work in Tx (WiFi 2.4GHz) mode.

3.6. Test Procedure

The EUT was placed on a non-metallic table, 80cm above the ground plane. The EUT Power Via PC connected to the power mains through a line impedance stabilization network (L.I.S.N. 1#). This provides a 50 ohm coupling impedance for the EUT (Please refer the block diagram of the test setup and photographs). The AC line is checked to find out the maximum conducted emission. In order to find the maximum emission levels, the relative positions of equipment and all of the interface cables shall be changed according to ANSI C63.10: 2013 on Conducted Emission Test.

The bandwidth of test receiver (R & S ESCI) is set at 9kHz.

The frequency range from 150kHz to 30MHz is checked.

3.7. Power Line Conducted Emission Test Results

PASS. (All emissions not reported below are too low against the prescribed limits.)

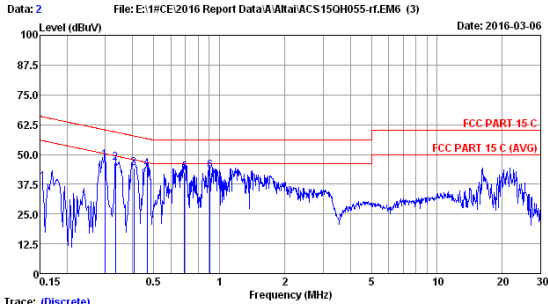

Trace: (Discrete)
 Site no :1# Conduction Data No :2
 Dis./Lism :2015 ESH2-25 LINE
 Limit :FCC PART 15 C
 Env./Ins. :25.2°C/53% Engineer :Alvis-Wu
 EUT :Altai A8in (ac) Super WiFi Base Station
 Power Rating :DC 56V From POE Input AC 120V/60Hz
 Test Mode :Tx Mode
 M/N:WA8011NAC-H

No	Freq (MHz)	LISM Factor (dB)	Cable Loss (dB)	Reading (dBuV)	Emission Level (dBuV)	Limits (dBuV)	Margin (dB)	Remark
1	0.299	0.13	0.05	47.47	47.65	60.28	12.63	QP
2	0.334	0.13	0.06	46.21	46.40	59.35	12.95	QP
3	0.406	0.74	0.06	43.66	44.46	57.73	13.27	QP
4	0.466	0.33	0.06	43.55	43.94	56.58	12.64	QP
5	0.694	0.15	0.06	42.23	42.44	56.00	13.56	QP
6	0.909	0.16	0.07	42.98	43.21	56.00	12.79	QP

Remarks: 1.Emission Level=LISM Factor+Cable Loss+Reading.
 2.If the average limit is met when using a quasi-peak detector, the EUT shall be deemed to meet both limits and measurement with average detector is unnecessary.

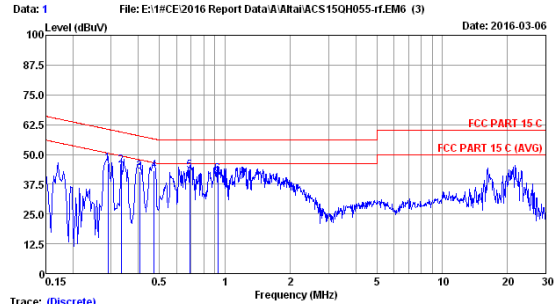

Trace: (Discrete)
 Site no :1# Conduction Data No :1
 Dis./Lism :2015 ESH2-25 NEUTRAL
 Limit :FCC PART 15 C
 Env./Ins. :25.2°C/53% Engineer :Alvis-Wu
 EUT :Altai A8in (ac) Super WiFi Base Station
 Power Rating :DC 56V From POE Input AC 120V/60Hz
 Test Mode :Tx Mode
 M/N:WA8011NAC-H

No	Freq (MHz)	LISM Factor (dB)	Cable Loss (dB)	Reading (dBuV)	Emission Level (dBuV)	Limits (dBuV)	Margin (dB)	Remark
1	0.289	0.13	0.05	45.82	46.00	60.54	14.54	QP
2	0.334	0.13	0.06	45.17	45.36	59.35	13.99	QP
3	0.406	0.14	0.06	42.44	42.64	57.73	15.09	QP
4	0.474	0.14	0.06	43.06	43.26	56.45	13.19	QP
5	0.690	0.15	0.06	43.14	43.35	56.00	12.65	QP
6	0.928	0.16	0.08	41.52	41.76	56.00	14.24	QP

Remarks: 1.Emission Level=LISM Factor+Cable Loss+Reading.
 2.If the average limit is met when using a quasi-peak detector, the EUT shall be deemed to meet both limits and measurement with average detector is unnecessary.

4. RADIATED EMISSION TEST

4.1. Test Equipment

4.1.1. For frequency range 30MHz~1000MHz (In 3m Anechoic Chamber)

Item	Equipment	Manufacturer	Model No.	Serial No.	Last Cal.	Cal. Interval
1.	3#Chamber	AUDIX	N/A	N/A	Mar.28,15	1 Year
2.	EMI Spectrum	Agilent	E4407B	MY41440292	Apr.28,15	1 Year
3.	Test Receiver	Rohde & Schwarz	ESVS10	834468/011	Apr.28,15	1 Year
4.	Amplifier	HP	8447D	2648A04738	Apr.28,15	1 Year
5.	Bilog Antenna	TESEQ	CBL6112D	35375	Jun.30,15	1 Year
6.	RF Cable	MIYAZAKI	CFD400-NW(3.5M)	No.3	Apr.28,15	1 Year
7.	RF Cable	MIYAZAKI	CFD400-LW(22M)	No.7	Apr.28,15	1 Year
8.	Coaxial Switch	Anritsu	MP59B	6201397222	Apr.28,15	1 Year
9.	Test Software	AUDIX	e3	6.2009-5-21a(n)	N/A	N/A

4.1.2. For frequency range 1GHz~40GHz (In 3m Anechoic Chamber)

Item	Equipment	Manufacturer	Model No.	Serial No.	Last Cal.	Cal. Interval
1.	Spectrum Analyzer	Agilent	E4446A	US44300459	Apr.28,15	1 Year
2.	Horn Antenna	ETS	MCTD 1209	DRH15F03006	Feb.03,15	1 Year
3.	Amplifier	Agilent	8449B	3008A02495	Apr.28,15	1 Year
4.	RF Cable	Hubersuhner	SUCOFLEX106	77977/6	Apr.28,15	1 Year
5.	Horn Antenna	ETS	3116	00060088	Nov.18.15	1 Year
6.	Test Software	AUDIX	E3	6.2009-5-21a(n)	N/A	N/A

4.2. Block Diagram of Test Setup

For frequency range 30MHz-1000MHz

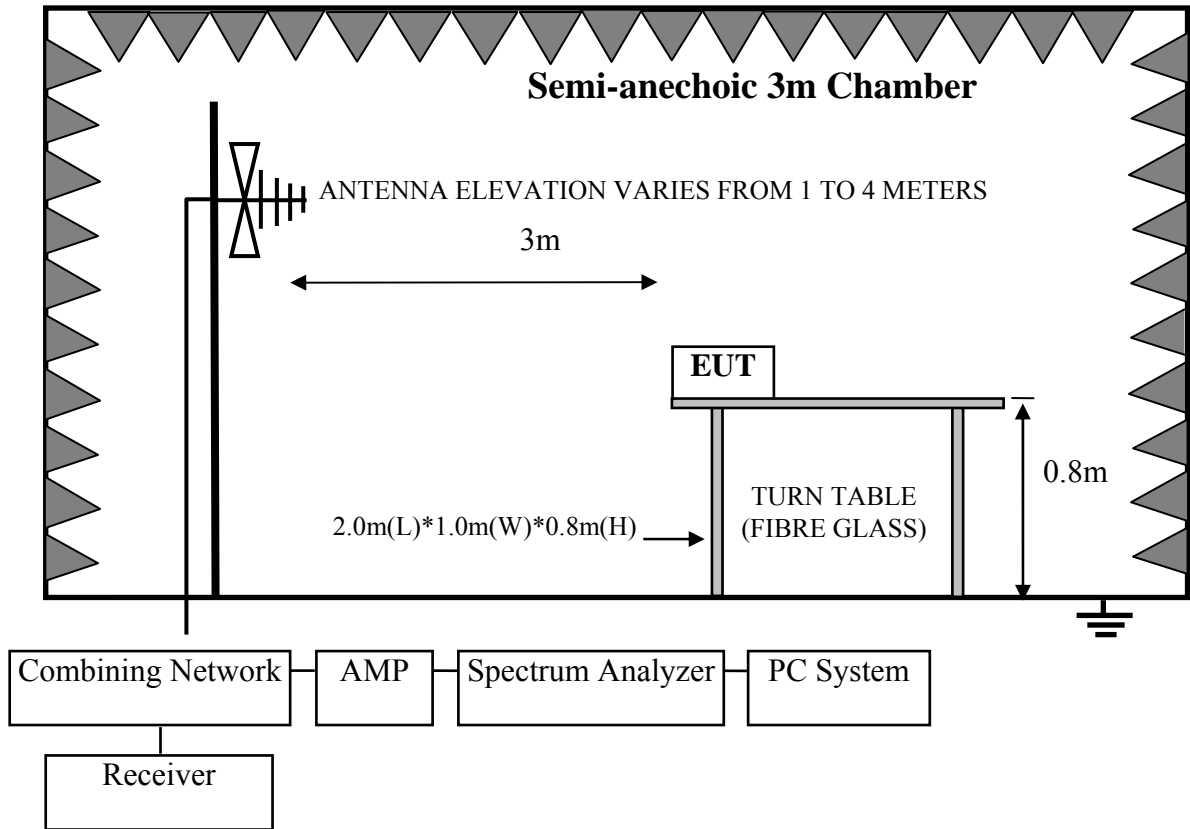

For frequency range 1GHz-25GHz

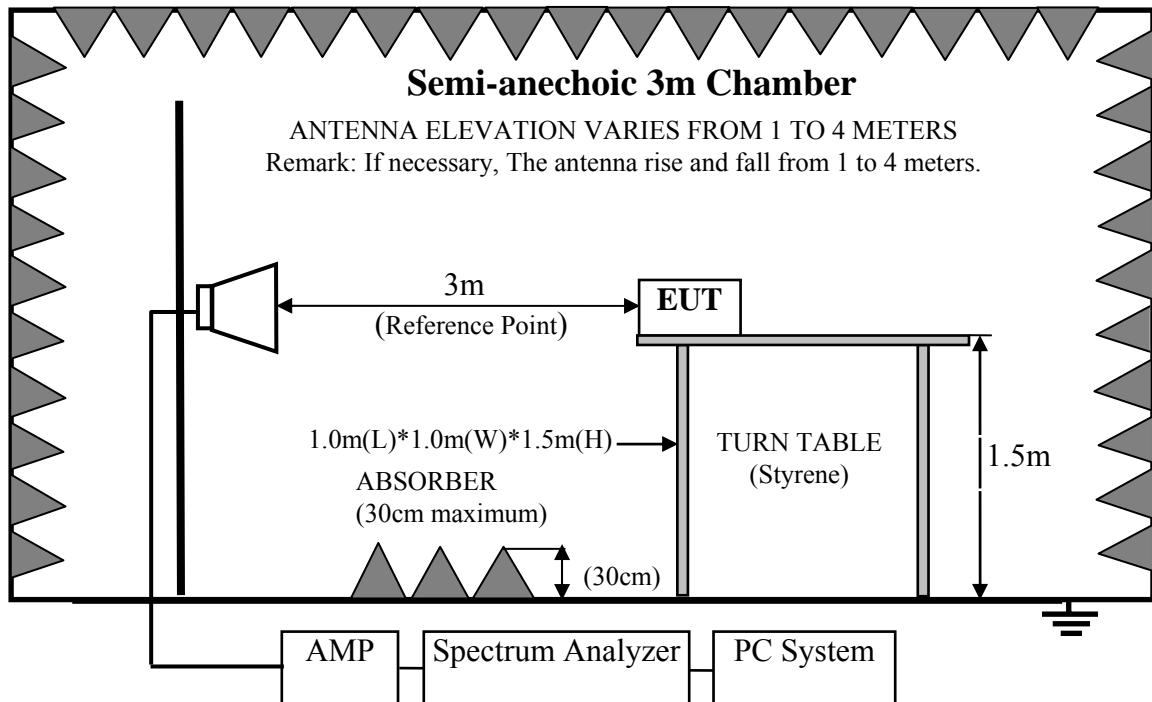

4.3. Radiated Emission Limit

4.3.1. 15.247&209 limits

FREQUENCY MHz	DISTANCE Meters	FIELD STRENGTHS LIMIT	
		μV/m	dB(μV)/m
30 ~ 88	3	100	40.0
88 ~ 216	3	150	43.5
216 ~ 960	3	200	46.0
960 ~ 1000	3	500	54.0
Above 1000	3	74.0 dB(μV)/m (Peak) 54.0 dB(μV)/m (Average)	

Remark : (1) Emission level dBμV = 20 log Emission level μV/m

(2) The smaller limit shall apply at the cross point between two frequency bands.

(3) Distance is the distance in meters between the measuring instrument, antenna and the closest point of any part of the device or system.

4.3.2. 15.205 Restricted bands of operation

MHz	MHz	MHz	GHz
0.090 - 0.110	16.42 - 16.423	399.9 - 410	4.5 - 5.15
¹ 0.495 - 0.505	16.69475 - 16.69525	608 - 614	5.35 - 5.46
2.1735 - 2.1905	16.80425 - 16.80475	960 - 1240	7.25 - 7.75
4.125 - 4.128	25.5 - 25.67	1300 - 1427	8.025 - 8.5
4.17725 - 4.17775	37.5 - 38.25	1435 - 1626.5	9.0 - 9.2
4.20725 - 4.20775	73 - 74.6	1645.5 - 1646.5	9.3 - 9.5
6.215 - 6.218	74.8 - 75.2	1660 - 1710	10.6 - 12.7
6.26775 - 6.26825	108 - 121.94	1718.8 - 1722.2	13.25 - 13.4
6.31175 - 6.31225	123 - 138	2200 - 2300	14.47 - 14.5
8.291 - 8.294	149.9 - 150.05	2310 - 2390	15.35 - 16.2
8.362 - 8.366	156.52475 - 156.52525	2483.5 - 2500	17.7 - 21.4
8.37625 - 8.38675	156.7 - 156.9	2690 - 2900	22.01 - 23.12
8.41425 - 8.41475	162.0125 - 167.17	3260 - 3267	23.6 - 24.0
12.29 - 12.293	167.72 - 173.2	3332 - 3339	31.2 - 31.8
12.51975 - 12.52025	240 - 285	3345.8 - 3358	36.43 - 36.5
12.57675 - 12.57725	322 - 335.4	3600 - 4400	(²)

All the emissions appearing within 15.205 restricted frequency bands shall not exceed the limits shown in 15.209, all the other emissions shall be at least 20dB below the fundamental emissions, or comply with 15.209 limits.

4.4. EUT Configuration on Test

The following equipment are installed on Power Line Conducted Emission Test to meet the commission requirement and operating regulations in a manner which tends to maximize its emission characteristics in a normal application.

4.4.1. Altai A8in (ac) Super WiFi Base Station (EUT)

Model Number : WA8011NAC-H

Serial Number : N/A

4.4.2. Support Equipment: As Tested Supporting System Details, in Section 2.2.

4.5. Operating Condition of EUT

- 4.5.1. Setup the EUT and simulator as shown as Section 4.2.
- 4.5.2. Turn on the power of all equipments.
- 4.5.3. Let EUT work in Tx (WiFi 2.4GHz) mode

4.6. Test Procedure

EUT and its simulators are placed on a turn table, which is 0.8 meter high above ground for frequency 30MHz~1000MHz, 1.5 meter high above ground for frequency above 1GHz and put the absorbing with 2.4m(L)*2.4m(W)*0.3m(H) on the ground. The turn table can rotate 360 degrees to determine the position of the maximum emission level. Power on the EUT and let it working in test mode, then test it. EUT is set 3 meters away from the receiving antenna, which is mounted on a antenna tower. The antenna can be moved up and down between 1 meter and 4 meters to find out the maximum emission level. Broadband antenna (calibrated bilog antenna) is used as receiving antenna for frequency 30MHz~1000MHz, and the Horn antenna is used as receiving antenna for frequency above 1GHz. Both horizontal and vertical polarization of the antenna are set on test.

This test was performed with EUT in X, Y, Z position, and the worse case was found when EUT in X position as test photo indicated.

The bandwidth of the EMI test receiver (R&S ESVS10) is set at 120kHz for frequency range from 30MHz to 1000 MHz.

The bandwidth of the Spectrum's VBW is set at 3MHz and RBW is set at 1MHz for peak emissions measurement above 1GHz and 1MHz RBW, 10Hz VBW for average emissions measure above 1GHz

The frequency range from 30MHz to 10th harmonic (25GHz) are checked. and no any emissions were found from 18GHz to 25GHz, So the radiated emissions from 18GHz to 25GHz were not record.

4.7. Radiated Emission Test Results

PASS.

All the emissions from 30MHz to 25 GHz were comply with 15.209 limits.

Note: For emissions above 1GHz, if peak level comply with average limit, then the average level is deemed to comply with average limit.

Duty cycle

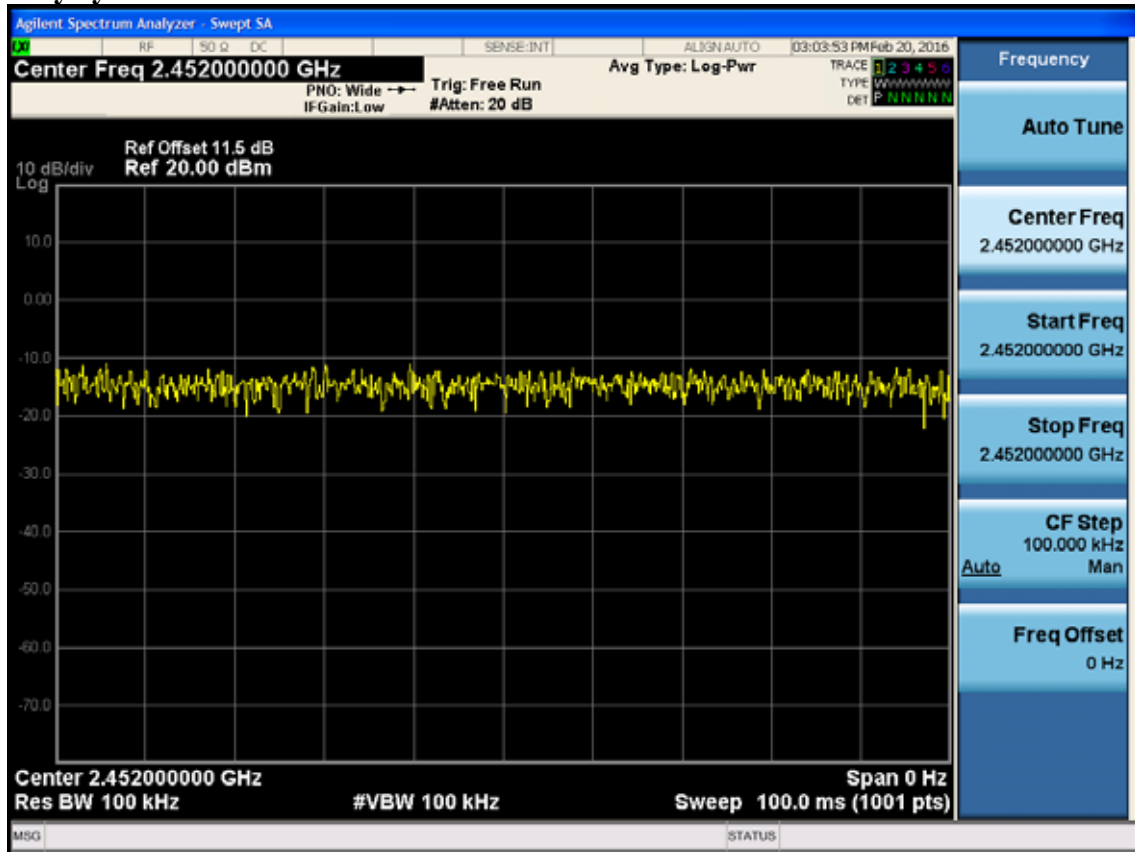

Note: The Duty Cycle is close to 100%.

Frequency: 30MHz~1GHz

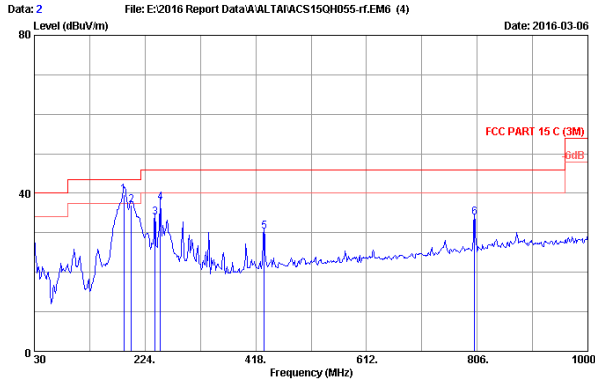

Site no. : 3m Chamber Data no. : 2
 Dis. / Ant. : 3m 2015 CBL6112D 35375 Ant. pol. : HORIZONTAL
 Limit : FCC PART 15 C (3M)
 Env. / Ins. : 20.6°C/55% Engineer : Donjon
 EUT : Altai 8Gin (ac) Super WiFi Base Station
 Power rating : DC 56V From POE Input AC 120V/60Hz
 Test Mode : Tx Mode
 WA8011NAC-H

No.	Freq. (MHz)	Ant. Factor (dB/m)	Cable Loss (dB)	Reading (dBuV)	Emission Level (dBuV/m)	Limits (dBuV/m)	Margin (dB)	Remark
1	187.140	10.21	1.46	27.98	39.65	43.50	3.85	QP
2	199.750	10.60	1.51	24.96	37.07	43.50	6.43	QP
3	241.460	12.76	1.65	19.53	33.94	46.00	12.06	QP
4	251.160	13.57	1.71	22.39	37.67	46.00	8.33	QP
5	432.550	17.39	2.31	10.53	30.23	46.00	15.77	QP
6	801.150	21.11	3.26	9.48	33.85	46.00	12.15	QP

Remarks: 1. Emission Level= Antenna Factor + Cable Loss + Reading.
 2. The emission levels that are 20dB below the official limit are not reported.

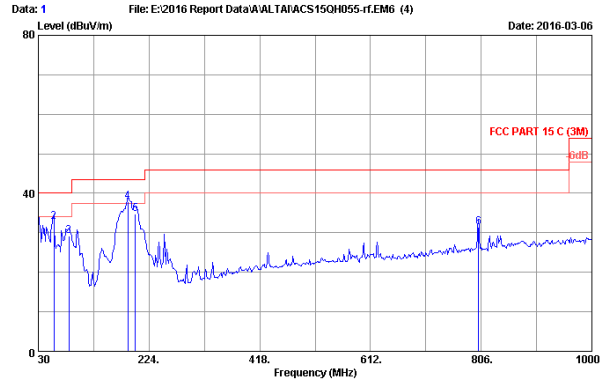

Site no. : 3m Chamber Data no. : 1
 Dis. / Ant. : 3m 2015 CBL6112D 35375 Ant. pol. : VERTICAL
 Limit : FCC PART 15 C (3M)
 Env. / Ins. : 20.6°C/55% Engineer : Donjon
 EUT : Altai 8Gin (ac) Super WiFi Base Station
 Power rating : DC 56V From POE Input AC 120V/60Hz
 Test Mode : Tx Mode
 WA8011NAC-H

No.	Freq. (MHz)	Ant. Factor (dB/m)	Cable Loss (dB)	Reading (dBuV)	Emission Level (dBuV/m)	Limits (dBuV/m)	Margin (dB)	Remark
1	30.000	20.30	0.51	11.73	32.54	40.00	7.46	QP
2	57.160	7.64	0.85	24.19	32.68	40.00	7.32	QP
3	83.350	8.43	1.02	19.83	29.28	40.00	10.72	QP
4	187.140	10.21	1.46	26.31	37.98	43.50	5.52	QP
5	199.750	10.60	1.51	22.58	34.69	43.50	8.81	QP
6	801.150	21.11	3.26	7.00	31.37	46.00	14.63	QP

Remarks: 1. Emission Level= Antenna Factor + Cable Loss + Reading.
 2. The emission levels that are 20dB below the official limit are not reported.

Frequency: 1GHz~18GHz

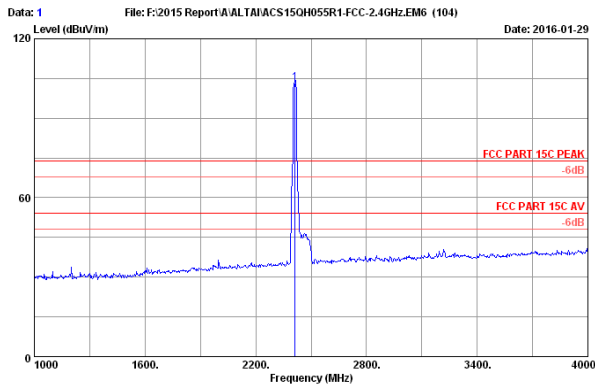

Site no. : 3m Chamber Data no. : 1
 Dis. / Ant. : 3m 2015 MCTD1209 3006 Ant. pol. : HORIZONTAL
 Limit : FCC PART 15C PEAK
 Env. / Ins. : 23°C/54%
 Engineer : Leo-Li
 EUT : Altai A8in (ac) Super WiFi Base Station
 Power rating : DC 56V From POE Input AC 120V/60Hz
 Test Mode : IEEE802.11b 2412Hz Tx
 WA8011NAC-H

No.	Freq. (MHz)	Ant. Factor (dB/m)	Cable Loss (dB)	AMP factor (dB)	Reading (dBuV)	Emission Level (dBuV/m)	Limits (dBuV/m)	Margin (dB)	Remark
1	2412.000	28.02	7.35	36.62	104.64	103.39	74.00	-29.39	Peak

Remarks: 1. Emission Level= Antenna Factor + Cable Loss + Reading - Amp Factor
 2. The emission levels that are 20dB below the official limit are not reported.

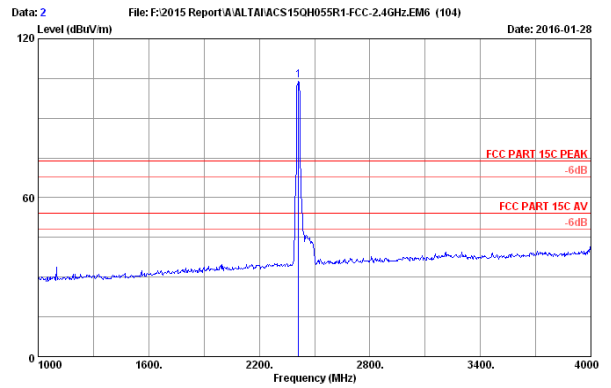

Site no. : 3m Chamber Data no. : 2
 Dis. / Ant. : 3m 2015 MCTD1209 3006 Ant. pol. : VERTICAL
 Limit : FCC PART 15C PEAK
 Env. / Ins. : 23°C/54%
 Engineer : Leo-Li
 EUT : Altai A8in (ac) Super WiFi Base Station
 Power rating : DC 56V From POE Input AC 120V/60Hz
 Test Mode : IEEE802.11b 2412Hz Tx
 WA8011NAC-H

No.	Freq. (MHz)	Ant. Factor (dB/m)	Cable Loss (dB)	AMP factor (dB)	Reading (dBuV)	Emission Level (dBuV/m)	Limits (dBuV/m)	Margin (dB)	Remark
1	2412.000	28.02	7.35	36.62	105.58	104.33	74.00	-30.33	Peak

Remarks: 1. Emission Level= Antenna Factor + Cable Loss + Reading - Amp Factor
 2. The emission levels that are 20dB below the official limit are not reported.

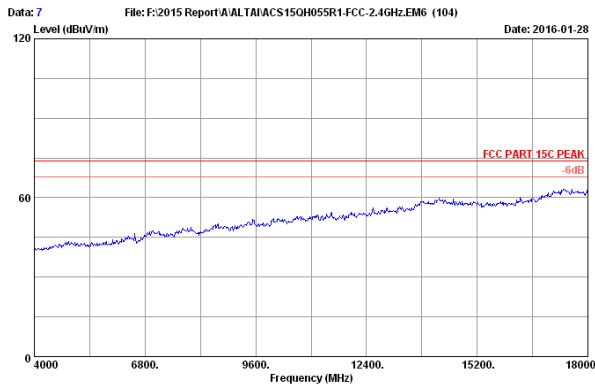

Site no. : 3m Chamber Data no. : 7
 Dis. / Ant. : 3m 2015 MCTD1209 3006 Ant. pol. : HORIZONTAL
 Limit : FCC PART 15C PEAK
 Env. / Ins. : 23°C/54%
 Engineer : Leo-Li
 EUT : Altai A8in (ac) Super WiFi Base Station
 Power rating : DC 56V From POE Input AC 120V/60Hz
 Test Mode : IEEE802.11b 2412Hz Tx
 WA8011NAC-H

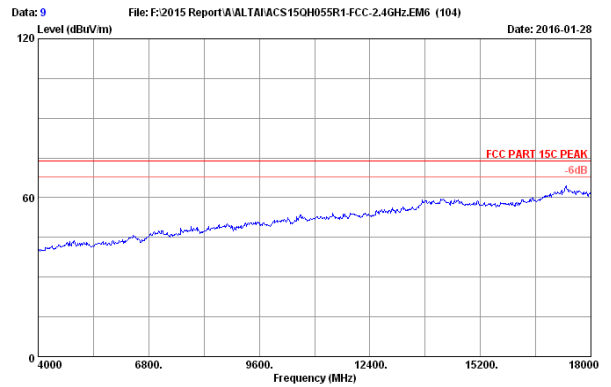

Site no. : 3m Chamber Data no. : 9
 Dis. / Ant. : 3m 2015 MCTD1209 3006 Ant. pol. : VERTICAL
 Limit : FCC PART 15C PEAK
 Env. / Ins. : 23°C/54%
 Engineer : Leo-Li
 EUT : Altai A8in (ac) Super WiFi Base Station
 Power rating : DC 56V From POE Input AC 120V/60Hz
 Test Mode : IEEE802.11b 2412Hz Tx
 WA8011NAC-H

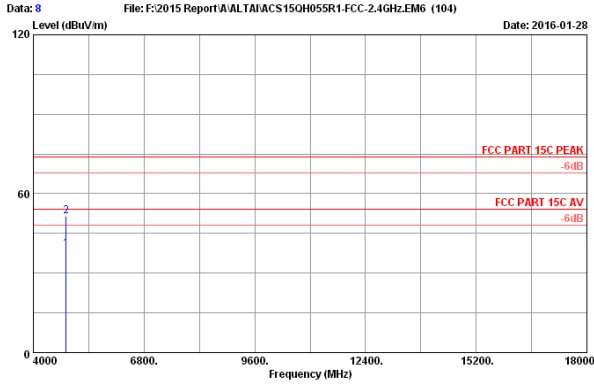

Site no. : 3m Chamber Data no. : 8
 Dis. / Ant. : 3m 2015 MCTD1209 3006 Ant. pol. : HORIZONTAL
 Limit : FCC PART 15C PEAK
 Env. / Ins. : 23°C/54%
 Engineer : Leo-Li
 EUT : Altai A8in (ac) Super WiFi Base Station
 Power rating : DC 56V From POE Input AC 120V/60Hz
 Test Mode : IEEE802.11b 2412Hz Tx
 WA8011NAC-H

No.	Freq. (MHz)	Ant. Factor (dB/m)	Cable Loss (dB)	AMP factor (dB)	Reading (dBuV)	Emission Level (dBuV/m)	Limits (dBuV/m)	Margin (dB)	Remark
1	4824.000	33.72	9.46	35.53	31.59	39.24	54.00	14.76	Average
2	4824.000	33.72	9.46	35.53	43.85	51.50	74.00	22.50	Peak

Remarks: 1. Emission Level= Antenna Factor + Cable Loss + Reading - Amp Factor
 2. The emission levels that are 20dB below the official limit are not reported.

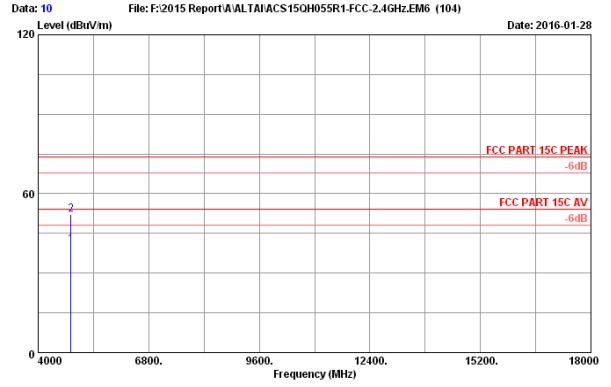

Site no. : 3m Chamber Data no. : 10
 Dis. / Ant. : 3m 2015 MCTD1209 3006 Ant. pol. : VERTICAL
 Limit : FCC PART 15C PEAK
 Env. / Ins. : 23°C/54%
 Engineer : Leo-Li
 EUT : Altai A8in (ac) Super WiFi Base Station
 Power rating : DC 56V From POE Input AC 120V/60Hz
 Test Mode : IEEE802.11b 2412Hz Tx
 WA8011NAC-H

No.	Freq. (MHz)	Ant. Factor (dB/m)	Cable Loss (dB)	AMP factor (dB)	Reading (dBuV)	Emission Level (dBuV/m)	Limits (dBuV/m)	Margin (dB)	Remark
1	4824.000	33.72	9.46	35.53	33.15	40.80	54.00	13.20	Average
2	4824.000	33.72	9.46	35.53	44.56	52.21	74.00	21.79	Peak

Remarks: 1. Emission Level= Antenna Factor + Cable Loss + Reading - Amp Factor
 2. The emission levels that are 20dB below the official limit are not reported.

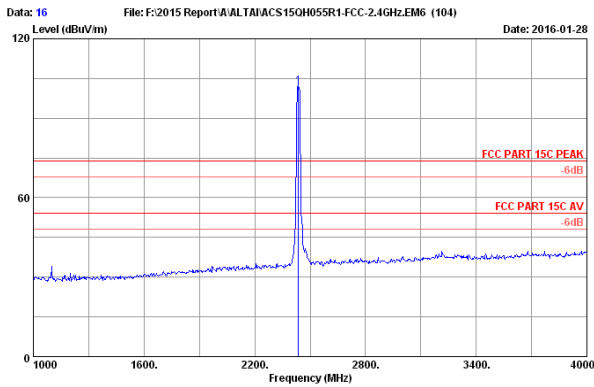

Site no. : 3m Chamber Data no. : 16
 Dis. / Ant. : 3m 2015 MCTD1209 3006 Ant. pol. : HORIZONTAL
 Limit : FCC PART 15C PEAK
 Env. / Ins. : 23°C/54%
 Engineer : Leo-Li
 EUT : Altai A8in (ac) Super WiFi Base Station
 Power rating : DC 56V From POE Input AC 120V/60Hz
 Test Mode : IEEE802.11b 2437Hz Tx
 WA8011NAC-H

No.	Freq. (MHz)	Ant. Factor (dB/m)	Cable Loss (dB)	AMP factor (dB)	Reading (dBuV)	Emission Level (dBuV/m)	Limits (dBuV/m)	Margin (dB)	Remark
1	2437.000	28.07	7.39	36.61	103.08	101.93	74.00	-27.93	Peak

Remarks: 1. Emission Level= Antenna Factor + Cable Loss + Reading - Amp Factor
 2. The emission levels that are 20dB below the official limit are not reported.

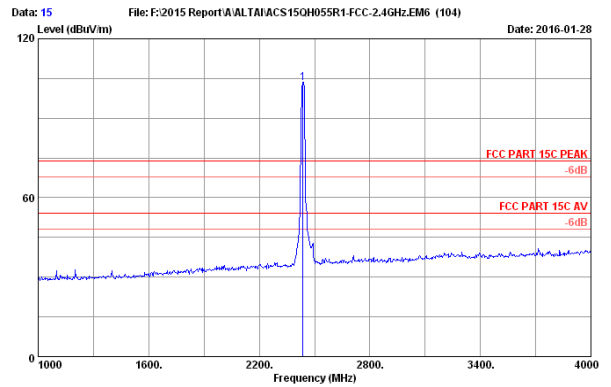

Site no. : 3m Chamber Data no. : 15
 Dis. / Ant. : 3m 2015 MCTD1209 3006 Ant. pol. : VERTICAL
 Limit : FCC PART 15C PEAK
 Env. / Ins. : 23°C/54%
 Engineer : Leo-Li
 EUT : Altai A8in (ac) Super WiFi Base Station
 Power rating : DC 56V From POE Input AC 120V/60Hz
 Test Mode : IEEE802.11b 2437Hz Tx
 WA8011NAC-H

No.	Freq. (MHz)	Ant. Factor (dB/m)	Cable Loss (dB)	AMP factor (dB)	Reading (dBuV)	Emission Level (dBuV/m)	Limits (dBuV/m)	Margin (dB)	Remark
1	2437.000	28.07	7.39	36.61	104.43	103.28	74.00	-29.28	Peak

Remarks: 1. Emission Level= Antenna Factor + Cable Loss + Reading - Amp Factor
 2. The emission levels that are 20dB below the official limit are not reported.

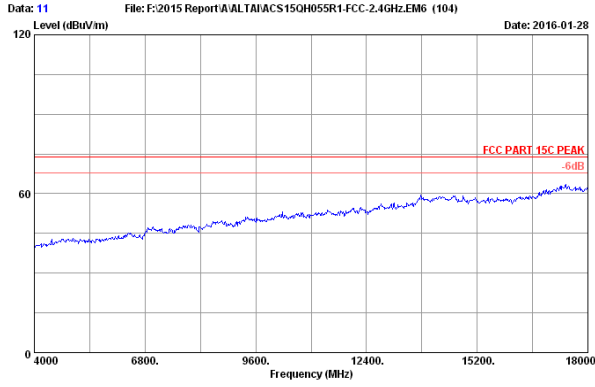

Site no. : 3m Chamber Data no. : 11
 Dis. / Ant. : 3m 2015 MCTD1209 3006 Ant. pol. : HORIZONTAL
 Limit : FCC PART 15C PEAK
 Env. / Ins. : 23°C/54%
 Engineer : Leo-Li
 EUT : Altai A8in (ac) Super WiFi Base Station
 Power rating : DC 56V From POE Input AC 120V/60Hz
 Test Mode : IEEE802.11b 2437Hz Tx
 WA8011NAC-H

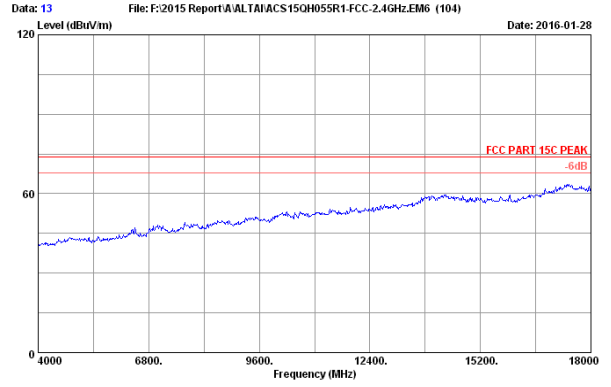

Site no. : 3m Chamber Data no. : 13
 Dis. / Ant. : 3m 2015 MCTD1209 3006 Ant. pol. : VERTICAL
 Limit : FCC PART 15C PEAK
 Env. / Ins. : 23°C/54%
 Engineer : Leo-Li
 EUT : Altai A8in (ac) Super WiFi Base Station
 Power rating : DC 56V From POE Input AC 120V/60Hz
 Test Mode : IEEE802.11b 2437Hz Tx
 WA8011NAC-H

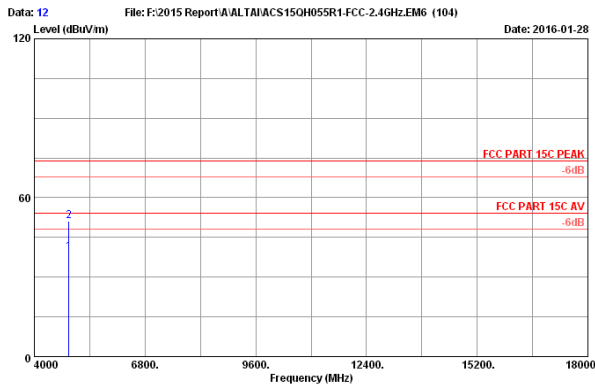

Site no. : 3m Chamber Data no. : 12
 Dis. / Ant. : 3m 2015 MCTD1209 3006 Ant. pol. : HORIZONTAL
 Limit : FCC PART 15C PEAK
 Env. / Ins. : 23°C/54%
 Engineer : Leo-Li
 EUT : Altai A8in (ac) Super WiFi Base Station
 Power rating : DC 56V From POE Input AC 120V/60Hz
 Test Mode : IEEE802.11b 2437Hz Tx
 WA8011NAC-H

No.	Freq. (MHz)	Ant. Factor (dB/m)	Cable Loss (dB)	AMP factor (dB)	Reading (dBuV)	Emission Level (dBuV/m)	Limits (dBuV/m)	Margin (dB)	Remark
1	4874.000	33.80	9.49	35.51	31.69	39.47	54.00	14.53	Average
2	4874.000	33.80	9.49	35.51	43.26	51.04	74.00	22.96	Peak

Remarks: 1. Emission Level= Antenna Factor + Cable Loss + Reading - Amp Factor
 2. The emission levels that are 20dB below the official limit are not reported.

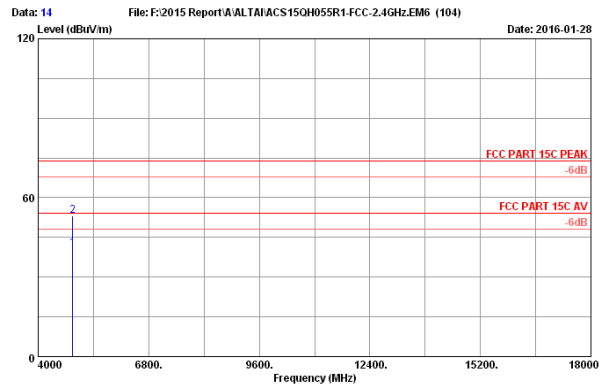

Site no. : 3m Chamber Data no. : 14
 Dis. / Ant. : 3m 2015 MCTD1209 3006 Ant. pol. : VERTICAL
 Limit : FCC PART 15C PEAK
 Env. / Ins. : 23°C/54%
 Engineer : Leo-Li
 EUT : Altai A8in (ac) Super WiFi Base Station
 Power rating : DC 56V From POE Input AC 120V/60Hz
 Test Mode : IEEE802.11b 2437Hz Tx
 WA8011NAC-H

No.	Freq. (MHz)	Ant. Factor (dB/m)	Cable Loss (dB)	AMP factor (dB)	Reading (dBuV)	Emission Level (dBuV/m)	Limits (dBuV/m)	Margin (dB)	Remark
1	4874.000	33.80	9.49	35.51	32.88	40.66	54.00	13.34	Average
2	4874.000	33.80	9.49	35.51	45.26	53.04	74.00	20.96	Peak

Remarks: 1. Emission Level= Antenna Factor + Cable Loss + Reading - Amp Factor
 2. The emission levels that are 20dB below the official limit are not reported.

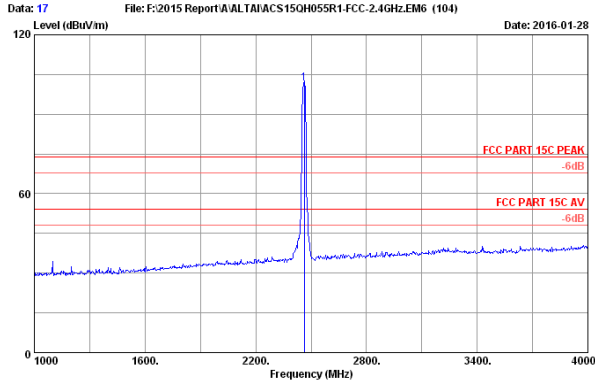

Site no. : 3m Chamber Data no. : 17
 Dis. / Ant. : 3m 2015 MCTD1209 3006 Ant. pol. : HORIZONTAL
 Limit : FCC PART 15C PEAK
 Env. / Ins. : 23°C/54%
 Engineer : Leo-Li
 EUT : Altai A8in (ac) Super WiFi Base Station
 Power rating : DC 56V From POE Input AC 120V/60Hz
 Test Mode : IEEE802.11b 2462Hz Tx
 WA8011NAC-H

No.	Freq. (MHz)	Ant. Factor (dB/m)	Cable Loss (dB)	AMP factor (dB)	Reading (dBuV)	Emission Level (dBuV/m)	Limits (dBuV/m)	Margin (dB)	Remark
1	2462.000	28.12	7.43	36.60	102.59	101.54	74.00	-27.54	Peak

Remarks: 1. Emission Level= Antenna Factor + Cable Loss + Reading - Amp Factor
 2. The emission levels that are 20dB below the official limit are not reported.

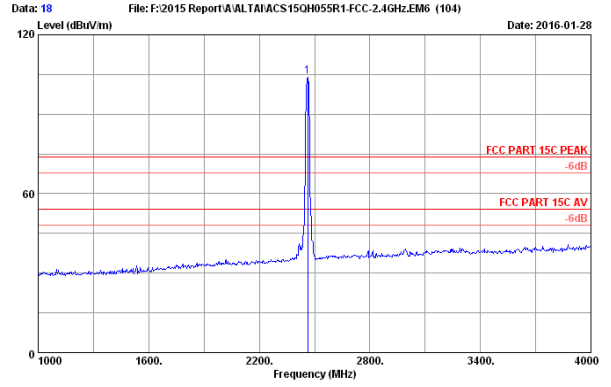

Site no. : 3m Chamber Data no. : 18
 Dis. / Ant. : 3m 2015 MCTD1209 3006 Ant. pol. : VERTICAL
 Limit : FCC PART 15C PEAK
 Env. / Ins. : 23°C/54%
 Engineer : Leo-Li
 EUT : Altai A8in (ac) Super WiFi Base Station
 Power rating : DC 56V From POE Input AC 120V/60Hz
 Test Mode : IEEE802.11b 2462Hz Tx
 WA8011NAC-H

No.	Freq. (MHz)	Ant. Factor (dB/m)	Cable Loss (dB)	AMP factor (dB)	Reading (dBuV)	Emission Level (dBuV/m)	Limits (dBuV/m)	Margin (dB)	Remark
1	2462.000	28.12	7.43	36.60	105.24	104.19	74.00	-30.19	Peak

Remarks: 1. Emission Level= Antenna Factor + Cable Loss + Reading - Amp Factor
 2. The emission levels that are 20dB below the official limit are not reported.

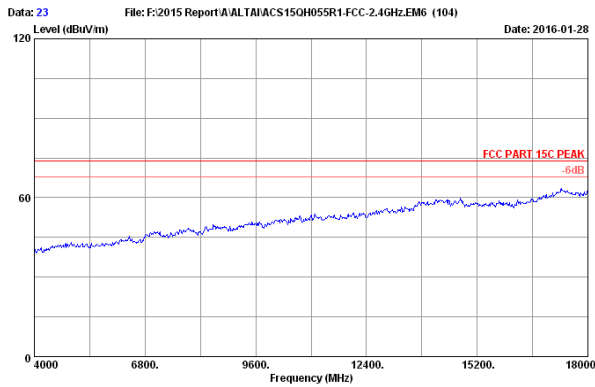

Site no. : 3m Chamber Data no. : 23
 Dis. / Ant. : 3m 2015 MCTD1209 3006 Ant. pol. : HORIZONTAL
 Limit : FCC PART 15C PEAK
 Env. / Ins. : 23°C/54%
 Engineer : Leo-Li
 EUT : Altai A8in (ac) Super WiFi Base Station
 Power rating : DC 56V From POE Input AC 120V/60Hz
 Test Mode : IEEE802.11b 2462Hz Tx
 WA8011NAC-H

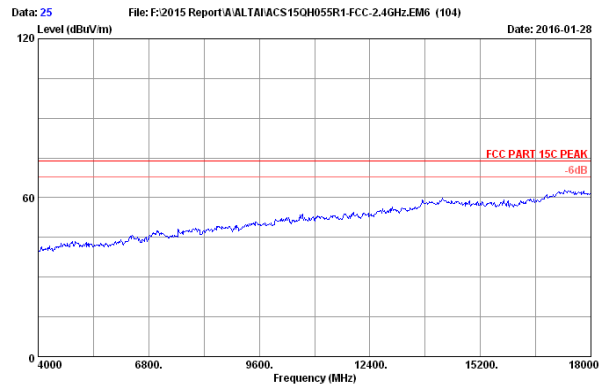

Site no. : 3m Chamber Data no. : 25
 Dis. / Ant. : 3m 2015 MCTD1209 3006 Ant. pol. : VERTICAL
 Limit : FCC PART 15C PEAK
 Env. / Ins. : 23°C/54%
 Engineer : Leo-Li
 EUT : Altai A8in (ac) Super WiFi Base Station
 Power rating : DC 56V From POE Input AC 120V/60Hz
 Test Mode : IEEE802.11b 2462Hz Tx
 WA8011NAC-H

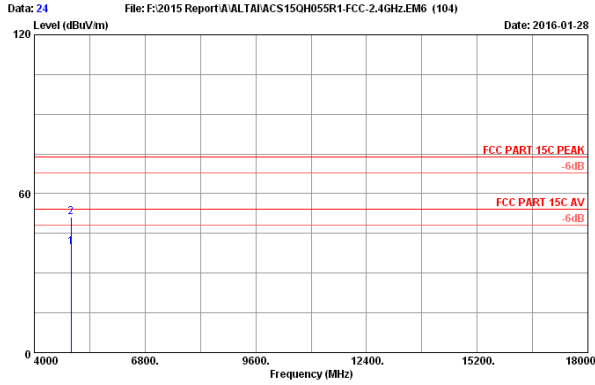

Site no. : 3m Chamber Data no. : 24
 Dis. / Ant. : 3m 2015 MCTD1209 3006 Ant. pol. : HORIZONTAL
 Limit : FCC PART 15C PEAK
 Env. / Ins. : 23°C/54%
 Engineer : Leo-Li
 EUT : Altai A8in (ac) Super WiFi Base Station
 Power rating : DC 56V From POE Input AC 120V/60Hz
 Test Mode : IEEE802.11b 2462Hz Tx
 WA8011NAC-H

No.	Freq. (MHz)	Ant. Factor (dB/m)	Cable Loss (dB)	AMP factor (dB)	Reading (dBuV)	Emission Level (dBuV/m)	Limits (dBuV/m)	Margin (dB)	Remark
1	4924.000	33.88	9.51	35.48	32.03	39.94	54.00	14.06	Average
2	4924.000	33.88	9.51	35.48	43.11	51.02	74.00	22.98	Peak

Remarks: 1. Emission Level= Antenna Factor + Cable Loss + Reading - Amp Factor
 2. The emission levels that are 20dB below the official limit are not reported.

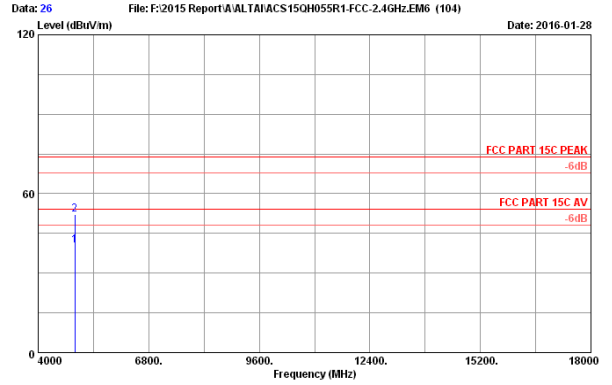

Site no. : 3m Chamber Data no. : 26
 Dis. / Ant. : 3m 2015 MCTD1209 3006 Ant. pol. : VERTICAL
 Limit : FCC PART 15C PEAK
 Env. / Ins. : 23°C/54%
 Engineer : Leo-Li
 EUT : Altai A8in (ac) Super WiFi Base Station
 Power rating : DC 56V From POE Input AC 120V/60Hz
 Test Mode : IEEE802.11b 2462Hz Tx
 WA8011NAC-H

No.	Freq. (MHz)	Ant. Factor (dB/m)	Cable Loss (dB)	AMP factor (dB)	Reading (dBuV)	Emission Level (dBuV/m)	Limits (dBuV/m)	Margin (dB)	Remark
1	4924.000	33.88	9.51	35.48	32.55	40.46	54.00	13.54	Average
2	4924.000	33.88	9.51	35.48	44.25	52.16	74.00	21.84	Peak

Remarks: 1. Emission Level= Antenna Factor + Cable Loss + Reading - Amp Factor
 2. The emission levels that are 20dB below the official limit are not reported.

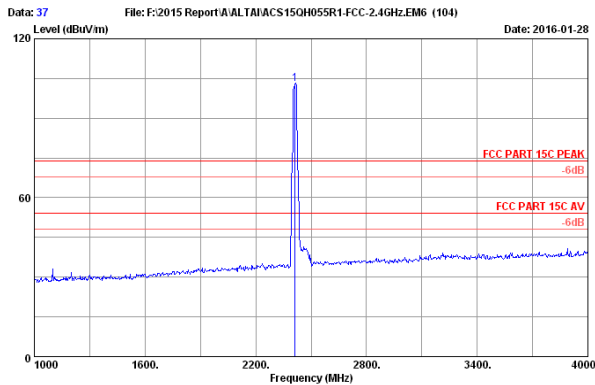

Site no. : 3m Chamber Data no. : 37
 Dis. / Ant. : 3m 2015 MCTD1209 3006 Ant. pol. : HORIZONTAL
 Limit : FCC PART 15C PEAK
 Env. / Ins. : 23°C/54%
 Engineer : Leo-Li
 EUT : Altai A8in (ac) Super WiFi Base Station
 Power rating : DC 56V From POE Input AC 120V/60Hz
 Test Mode : IEEE802.11g 2412Hz Tx
 WA8011NAC-H

No.	Freq. (MHz)	Ant. Factor (dB/m)	Cable Loss (dB)	AMP factor (dB)	Reading (dBuV)	Emission Level (dBuV/m)	Limits (dBuV/m)	Margin (dB)	Remark
1	2412.000	28.02	7.35	36.62	104.27	103.02	74.00	-29.02	Peak

Remarks: 1. Emission Level= Antenna Factor + Cable Loss + Reading - Amp Factor
 2. The emission levels that are 20dB below the official limit are not reported.

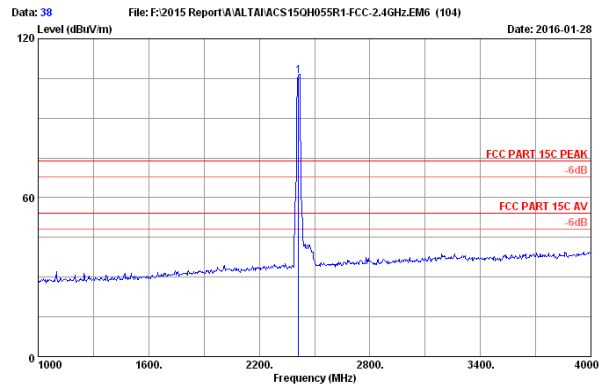

Site no. : 3m Chamber Data no. : 38
 Dis. / Ant. : 3m 2015 MCTD1209 3006 Ant. pol. : VERTICAL
 Limit : FCC PART 15C PEAK
 Env. / Ins. : 23°C/54%
 Engineer : Leo-Li
 EUT : Altai A8in (ac) Super WiFi Base Station
 Power rating : DC 56V From POE Input AC 120V/60Hz
 Test Mode : IEEE802.11g 2412Hz Tx
 WA8011NAC-H

No.	Freq. (MHz)	Ant. Factor (dB/m)	Cable Loss (dB)	AMP factor (dB)	Reading (dBuV)	Emission Level (dBuV/m)	Limits (dBuV/m)	Margin (dB)	Remark
1	2412.000	28.02	7.35	36.62	107.27	106.02	74.00	-32.02	Peak

Remarks: 1. Emission Level= Antenna Factor + Cable Loss + Reading - Amp Factor
 2. The emission levels that are 20dB below the official limit are not reported.

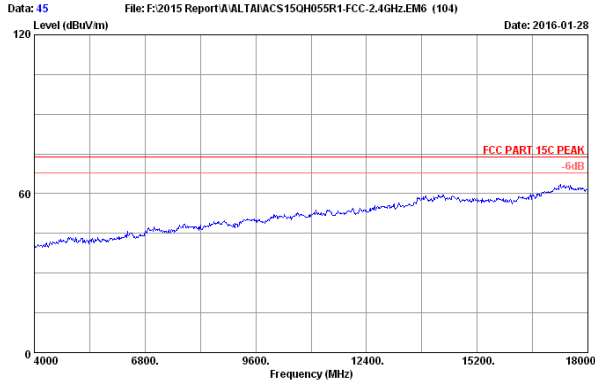

Site no. : 3m Chamber Data no. : 45
 Dis. / Ant. : 3m 2015 MCTD1209 3006 Ant. pol. : HORIZONTAL
 Limit : FCC PART 15C PEAK
 Env. / Ins. : 23°C/54%
 Engineer : Leo-Li
 EUT : Altai A8in (ac) Super WiFi Base Station
 Power rating : DC 56V From POE Input AC 120V/60Hz
 Test Mode : IEEE802.11g 2412Hz Tx
 WA8011NAC-H

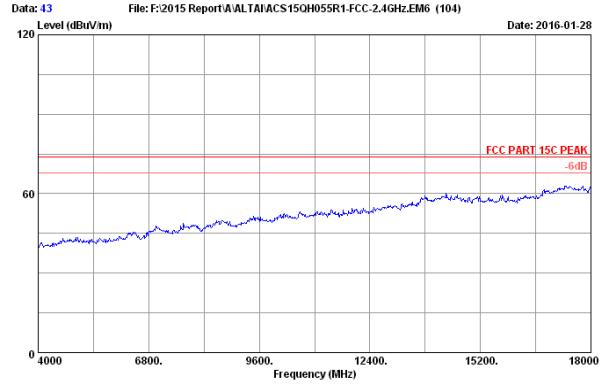

Site no. : 3m Chamber Data no. : 43
 Dis. / Ant. : 3m 2015 MCTD1209 3006 Ant. pol. : VERTICAL
 Limit : FCC PART 15C PEAK
 Env. / Ins. : 23°C/54%
 Engineer : Leo-Li
 EUT : Altai A8in (ac) Super WiFi Base Station
 Power rating : DC 56V From POE Input AC 120V/60Hz
 Test Mode : IEEE802.11g 2412Hz Tx
 WA8011NAC-H

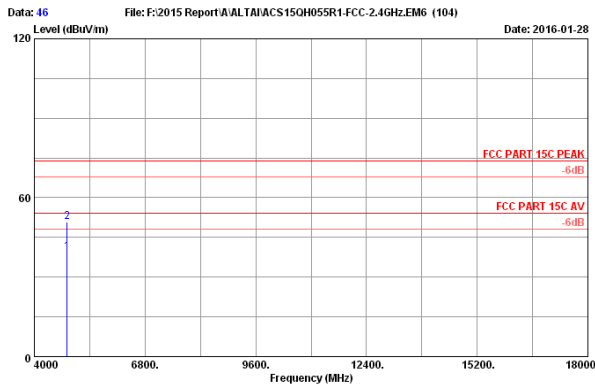

Site no. : 3m Chamber Data no. : 46
 Dis. / Ant. : 3m 2015 MCTD1209 3006 Ant. pol. : HORIZONTAL
 Limit : FCC PART 15C PEAK
 Env. / Ins. : 23°C/54%
 Engineer : Leo-Li
 EUT : Altai A8in (ac) Super WiFi Base Station
 Power rating : DC 56V From POE Input AC 120V/60Hz
 Test Mode : IEEE802.11g 2412Hz Tx
 WA8011NAC-H

No.	Freq. (MHz)	Ant. Factor (dB/m)	Cable Loss (dB)	AMP factor (dB)	Reading (dBuV)	Emission Level (dBuV/m)	Limits (dBuV/m)	Margin (dB)	Remark
1	4824.000	33.72	9.46	35.53	31.65	39.30	54.00	14.70	Average
2	4824.000	33.72	9.46	35.53	43.12	50.77	74.00	23.23	Peak

Remarks: 1. Emission Level= Antenna Factor + Cable Loss + Reading - Amp Factor
 2. The emission levels that are 20dB below the official limit are not reported.

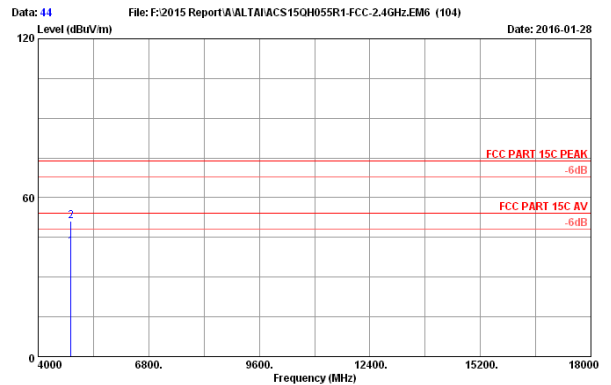

Site no. : 3m Chamber Data no. : 44
 Dis. / Ant. : 3m 2015 MCTD1209 3006 Ant. pol. : VERTICAL
 Limit : FCC PART 15C PEAK
 Env. / Ins. : 23°C/54%
 Engineer : Leo-Li
 EUT : Altai A8in (ac) Super WiFi Base Station
 Power rating : DC 56V From POE Input AC 120V/60Hz
 Test Mode : IEEE802.11g 2412Hz Tx
 WA8011NAC-H

No.	Freq. (MHz)	Ant. Factor (dB/m)	Cable Loss (dB)	AMP factor (dB)	Reading (dBuV)	Emission Level (dBuV/m)	Limits (dBuV/m)	Margin (dB)	Remark
1	4824.000	33.72	9.46	35.53	33.89	41.54	54.00	12.46	Average
2	4824.000	33.72	9.46	35.53	43.65	51.30	74.00	22.70	Peak

Remarks: 1. Emission Level= Antenna Factor + Cable Loss + Reading - Amp Factor
 2. The emission levels that are 20dB below the official limit are not reported.

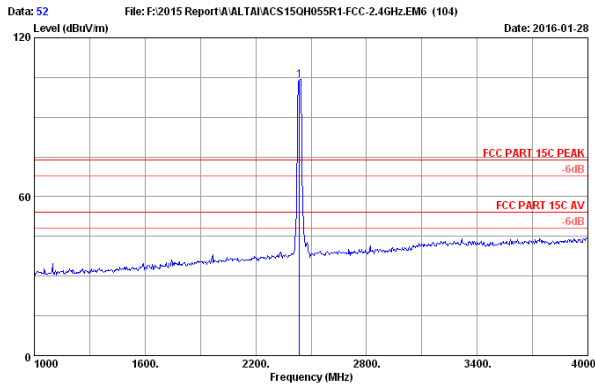

Site no. : 3m Chamber Data no. : 52
 Dis. / Ant. : 3m 2015 MCTD1209 3006 Ant. pol. : HORIZONTAL
 Limit : FCC PART 15C PEAK
 Env. / Ins. : 23°C/54%
 Engineer : Leo-Li
 EUT : Altai A8in (ac) Super WiFi Base Station
 Power rating : DC 56V From POE Input AC 120V/60Hz
 Test Mode : IEEE802.11g 2437Hz Tx
 WA8011NAC-H

No.	Freq. (MHz)	Ant. Factor (dB/m)	Cable Loss (dB)	AMP factor (dB)	Reading (dBuV)	Emission Level (dBuV/m)	Limits (dBuV/m)	Margin (dB)	Remark
1	2437.000	28.07	7.39	36.61	105.22	104.07	74.00	-30.07	Peak

Remarks: 1. Emission Level= Antenna Factor + Cable Loss + Reading - Amp Factor
 2. The emission levels that are 20dB below the official limit are not reported.

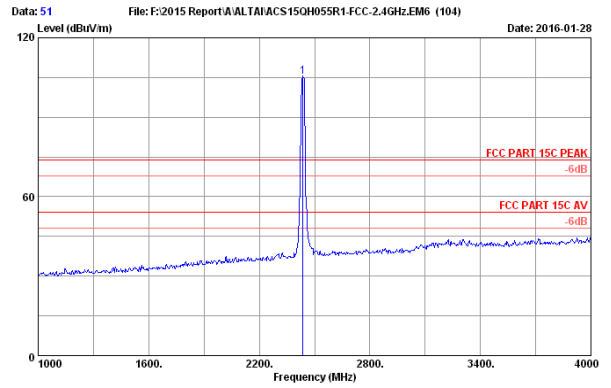

Site no. : 3m Chamber Data no. : 51
 Dis. / Ant. : 3m 2015 MCTD1209 3006 Ant. pol. : VERTICAL
 Limit : FCC PART 15C PEAK
 Env. / Ins. : 23°C/54%
 Engineer : Leo-Li
 EUT : Altai A8in (ac) Super WiFi Base Station
 Power rating : DC 56V From POE Input AC 120V/60Hz
 Test Mode : IEEE802.11g 2437Hz Tx
 WA8011NAC-H

No.	Freq. (MHz)	Ant. Factor (dB/m)	Cable Loss (dB)	AMP factor (dB)	Reading (dBuV)	Emission Level (dBuV/m)	Limits (dBuV/m)	Margin (dB)	Remark
1	2437.000	28.07	7.39	36.61	106.55	105.40	74.00	-31.40	Peak

Remarks: 1. Emission Level= Antenna Factor + Cable Loss + Reading - Amp Factor
 2. The emission levels that are 20dB below the official limit are not reported.

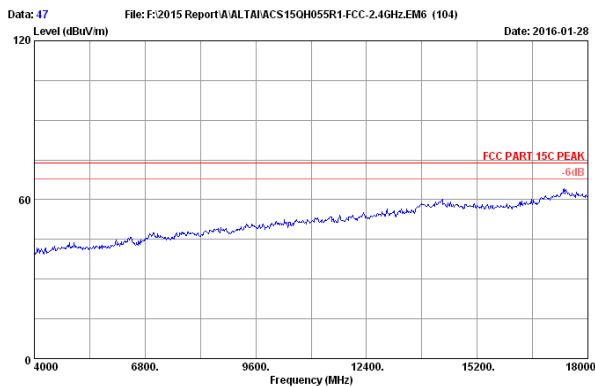

Site no. : 3m Chamber Data no. : 47
 Dis. / Ant. : 3m 2015 MCTD1209 3006 Ant. pol. : HORIZONTAL
 Limit : FCC PART 15C PEAK
 Env. / Ins. : 23°C/54%
 Engineer : Leo-Li
 EUT : Altai A8in (ac) Super WiFi Base Station
 Power rating : DC 56V From POE Input AC 120V/60Hz
 Test Mode : IEEE802.11g 2437Hz Tx
 WA8011NAC-H

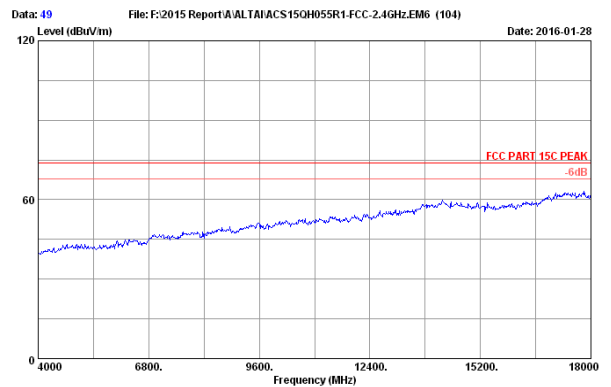

Site no. : 3m Chamber Data no. : 49
 Dis. / Ant. : 3m 2015 MCTD1209 3006 Ant. pol. : VERTICAL
 Limit : FCC PART 15C PEAK
 Env. / Ins. : 23°C/54%
 Engineer : Leo-Li
 EUT : Altai A8in (ac) Super WiFi Base Station
 Power rating : DC 56V From POE Input AC 120V/60Hz
 Test Mode : IEEE802.11g 2437Hz Tx
 WA8011NAC-H

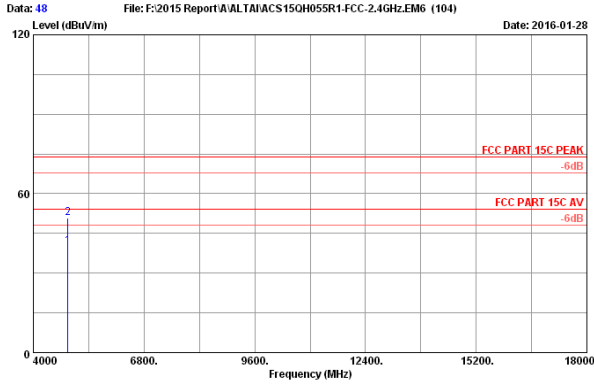

Site no. : 3m Chamber Data no. : 48
 Dis. / Ant. : 3m 2015 MCTD1209 3006 Ant. pol. : HORIZONTAL
 Limit : FCC PART 15C PEAK
 Env. / Ins. : 23°C/54%
 Engineer : Leo-Li
 EUT : Altai A8in (ac) Super WiFi Base Station
 Power rating : DC 56V From POE Input AC 120V/60Hz
 Test Mode : IEEE802.11g 2437Hz Tx
 WA8011NAC-H

No.	Freq. (MHz)	Ant. Factor (dB/m)	Cable Loss (dB)	AMP factor (dB)	Reading (dBuV)	Emission Level (dBuV/m)	Limits (dBuV/m)	Margin (dB)	Remark
1	4874.000	33.80	9.49	35.51	32.24	40.02	54.00	13.98	Average
2	4874.000	33.80	9.49	35.51	43.07	50.85	74.00	23.15	Peak

Remarks: 1. Emission Level= Antenna Factor + Cable Loss + Reading - Amp Factor
 2. The emission levels that are 20dB below the official limit are not reported.

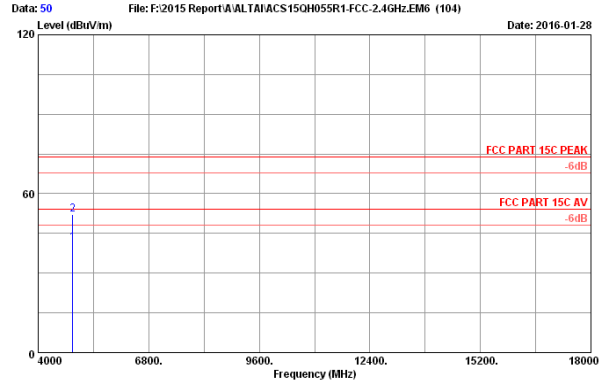

Site no. : 3m Chamber Data no. : 50
 Dis. / Ant. : 3m 2015 MCTD1209 3006 Ant. pol. : VERTICAL
 Limit : FCC PART 15C PEAK
 Env. / Ins. : 23°C/54%
 Engineer : Leo-Li
 EUT : Altai A8in (ac) Super WiFi Base Station
 Power rating : DC 56V From POE Input AC 120V/60Hz
 Test Mode : IEEE802.11g 2437Hz Tx
 WA8011NAC-H

No.	Freq. (MHz)	Ant. Factor (dB/m)	Cable Loss (dB)	AMP factor (dB)	Reading (dBuV)	Emission Level (dBuV/m)	Limits (dBuV/m)	Margin (dB)	Remark
1	4874.000	33.80	9.49	35.51	33.67	41.45	54.00	12.55	Average
2	4874.000	33.80	9.49	35.51	44.35	52.13	74.00	21.87	Peak

Remarks: 1. Emission Level= Antenna Factor + Cable Loss + Reading - Amp Factor
 2. The emission levels that are 20dB below the official limit are not reported.

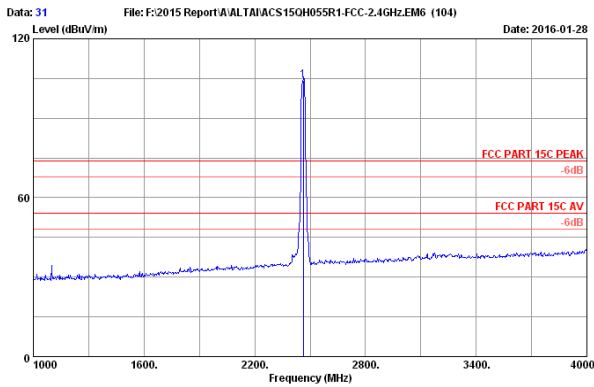

Site no. : 3m Chamber Data no. : 31
 Dis. / Ant. : 3m 2015 MCTD1209 3006 Ant. pol. : HORIZONTAL
 Limit : FCC PART 15C PEAK
 Env. / Ins. : 23°C/54%
 Engineer : Leo-Li
 EUT : Altai A8in (ac) Super WiFi Base Station
 Power rating : DC 56V From POE Input AC 120V/60Hz
 Test Mode : IEEE802.11g 2462Hz Tx
 WA8011NAC-H

No.	Freq. (MHz)	Ant. Factor (dB/m)	Cable Loss (dB)	AMP factor (dB)	Reading (dBuV)	Emission Level (dBuV/m)	Limits (dBuV/m)	Margin (dB)	Remark
1	2462.000	28.12	7.43	36.60	105.24	104.19	74.00	-30.19	Peak

Remarks: 1. Emission Level= Antenna Factor + Cable Loss + Reading - Amp Factor
 2. The emission levels that are 20dB below the official limit are not reported.

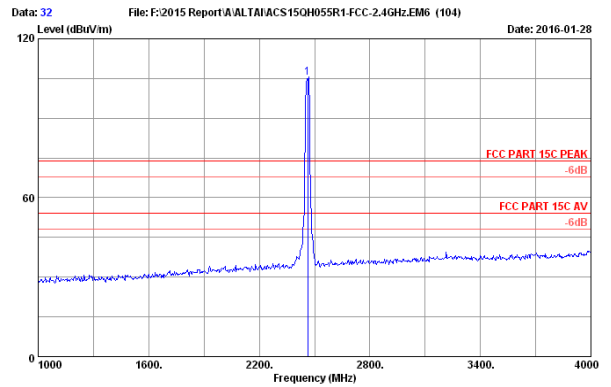

Site no. : 3m Chamber Data no. : 32
 Dis. / Ant. : 3m 2015 MCTD1209 3006 Ant. pol. : VERTICAL
 Limit : FCC PART 15C PEAK
 Env. / Ins. : 23°C/54%
 Engineer : Leo-Li
 EUT : Altai A8in (ac) Super WiFi Base Station
 Power rating : DC 56V From POE Input AC 120V/60Hz
 Test Mode : IEEE802.11g 2462Hz Tx
 WA8011NAC-H

No.	Freq. (MHz)	Ant. Factor (dB/m)	Cable Loss (dB)	AMP factor (dB)	Reading (dBuV)	Emission Level (dBuV/m)	Limits (dBuV/m)	Margin (dB)	Remark
1	2462.000	28.12	7.43	36.60	106.27	105.22	74.00	-31.22	Peak

Remarks: 1. Emission Level= Antenna Factor + Cable Loss + Reading - Amp Factor
 2. The emission levels that are 20dB below the official limit are not reported.

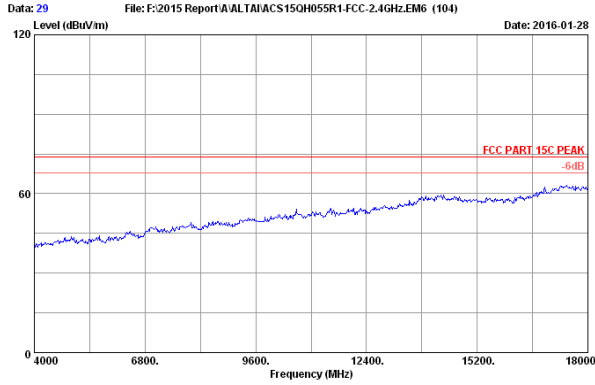

Site no. : 3m Chamber Data no. : 29
 Dis. / Ant. : 3m 2015 MCTD1209 3006 Ant. pol. : HORIZONTAL
 Limit : FCC PART 15C PEAK
 Env. / Ins. : 23°C/54%
 Engineer : Leo-Li
 EUT : Altai A8in (ac) Super WiFi Base Station
 Power rating : DC 56V From POE Input AC 120V/60Hz
 Test Mode : IEEE802.11g 2462Hz Tx
 WA8011NAC-H

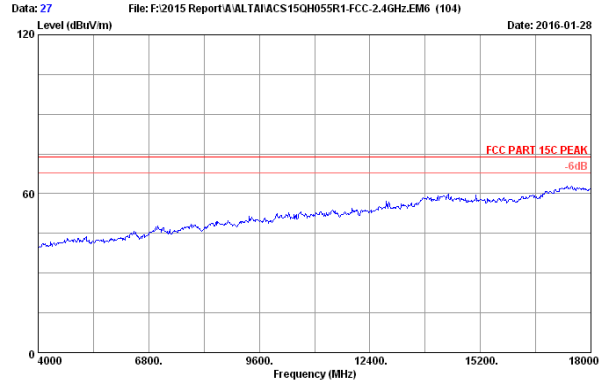

Site no. : 3m Chamber Data no. : 27
 Dis. / Ant. : 3m 2015 MCTD1209 3006 Ant. pol. : VERTICAL
 Limit : FCC PART 15C PEAK
 Env. / Ins. : 23°C/54%
 Engineer : Leo-Li
 EUT : Altai A8in (ac) Super WiFi Base Station
 Power rating : DC 56V From POE Input AC 120V/60Hz
 Test Mode : IEEE802.11g 2462Hz Tx
 WA8011NAC-H

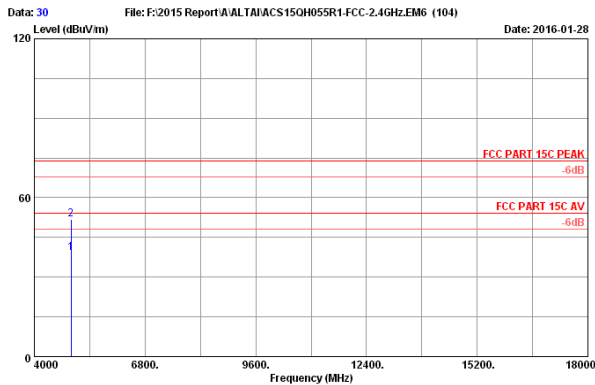

Site no. : 3m Chamber Data no. : 30
 Dis. / Ant. : 3m 2015 MCTD1209 3006 Ant. pol. : HORIZONTAL
 Limit : FCC PART 15C PEAK
 Env. / Ins. : 23°C/54%
 Engineer : Leo-Li
 EUT : Altai A8in (ac) Super WiFi Base Station
 Power rating : DC 56V From POE Input AC 120V/60Hz
 Test Mode : IEEE802.11g 2462Hz Tx
 WA8011NAC-H

No.	Freq. (MHz)	Ant. Factor (dB/m)	Cable Loss (dB)	AMP factor (dB)	Reading (dBuV)	Emission Level (dBuV/m)	Limits (dBuV/m)	Margin (dB)	Remark
1	4924.000	33.88	9.51	35.48	31.25	39.16	54.00	14.84	Average
2	4924.000	33.88	9.51	35.48	44.02	51.93	74.00	22.07	Peak

Remarks: 1. Emission Level= Antenna Factor + Cable Loss + Reading - Amp Factor
 2. The emission levels that are 20dB below the official limit are not reported.

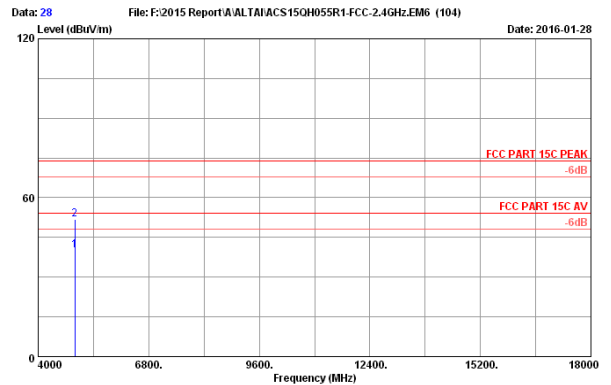

Site no. : 3m Chamber Data no. : 28
 Dis. / Ant. : 3m 2015 MCTD1209 3006 Ant. pol. : VERTICAL
 Limit : FCC PART 15C PEAK
 Env. / Ins. : 23°C/54%
 Engineer : Leo-Li
 EUT : Altai A8in (ac) Super WiFi Base Station
 Power rating : DC 56V From POE Input AC 120V/60Hz
 Test Mode : IEEE802.11g 2462Hz Tx
 WA8011NAC-H

No.	Freq. (MHz)	Ant. Factor (dB/m)	Cable Loss (dB)	AMP factor (dB)	Reading (dBuV)	Emission Level (dBuV/m)	Limits (dBuV/m)	Margin (dB)	Remark
1	4924.000	33.88	9.51	35.48	32.13	40.04	54.00	13.96	Average
2	4924.000	33.88	9.51	35.48	44.01	51.92	74.00	22.08	Peak

Remarks: 1. Emission Level= Antenna Factor + Cable Loss + Reading - Amp Factor
 2. The emission levels that are 20dB below the official limit are not reported.

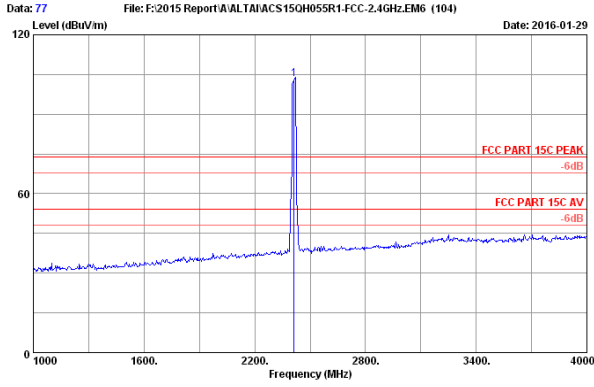

Site no. : 3m Chamber Data no. : 77
 Dis. / Ant. : 3m 2015 MCTD1209 3006 Ant. pol. : HORIZONTAL
 Limit : FCC PART 15C PEAK
 Env. / Ins. : 23°C/54%
 Engineer : Leo-Li
 EUT : Altai A8in (ac) Super WiFi Base Station
 Power rating : DC 56V From POE Input AC 120V/60Hz
 Test Mode : IEEE802.11nHT20 2412Hz Tx
 WA8011NAC-H

No.	Freq. (MHz)	Ant. Factor (dB/m)	Cable Loss (dB)	AMP factor (dB)	Reading (dBuV)	Emission Level (dBuV/m)	Limits (dBuV/m)	Margin (dB)	Remark
1	2412.000	28.02	7.35	36.62	104.66	103.41	74.00	-29.41	Peak

Remarks: 1. Emission Level= Antenna Factor + Cable Loss + Reading - Amp Factor
 2. The emission levels that are 20dB below the official limit are not reported.

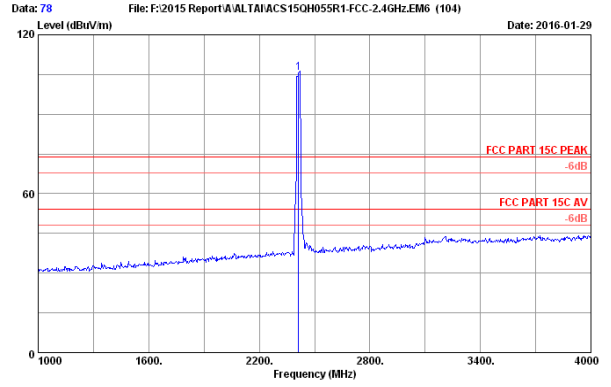

Site no. : 3m Chamber Data no. : 78
 Dis. / Ant. : 3m 2015 MCTD1209 3006 Ant. pol. : VERTICAL
 Limit : FCC PART 15C PEAK
 Env. / Ins. : 23°C/54%
 Engineer : Leo-Li
 EUT : Altai A8in (ac) Super WiFi Base Station
 Power rating : DC 56V From POE Input AC 120V/60Hz
 Test Mode : IEEE802.11nHT20 2412Hz Tx
 WA8011NAC-H

No.	Freq. (MHz)	Ant. Factor (dB/m)	Cable Loss (dB)	AMP factor (dB)	Reading (dBuV)	Emission Level (dBuV/m)	Limits (dBuV/m)	Margin (dB)	Remark
1	2412.000	28.02	7.35	36.62	106.99	105.74	74.00	-31.74	Peak

Remarks: 1. Emission Level= Antenna Factor + Cable Loss + Reading - Amp Factor
 2. The emission levels that are 20dB below the official limit are not reported.

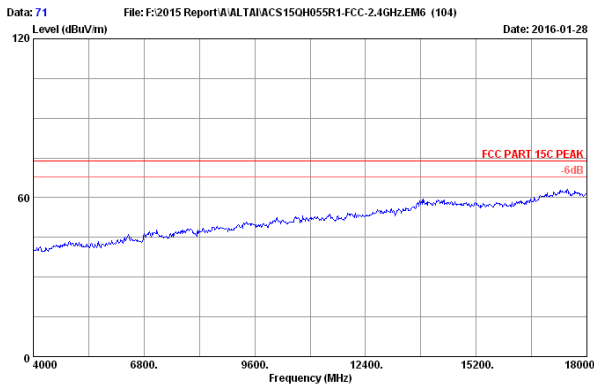

Site no. : 3m Chamber Data no. : 71
 Dis. / Ant. : 3m 2015 MCTD1209 3006 Ant. pol. : HORIZONTAL
 Limit : FCC PART 15C PEAK
 Env. / Ins. : 23°C/54%
 Engineer : Leo-Li
 EUT : Altai A8in (ac) Super WiFi Base Station
 Power rating : DC 56V From POE Input AC 120V/60Hz
 Test Mode : IEEE802.11nHT20 2412Hz Tx
 WA8011NAC-H

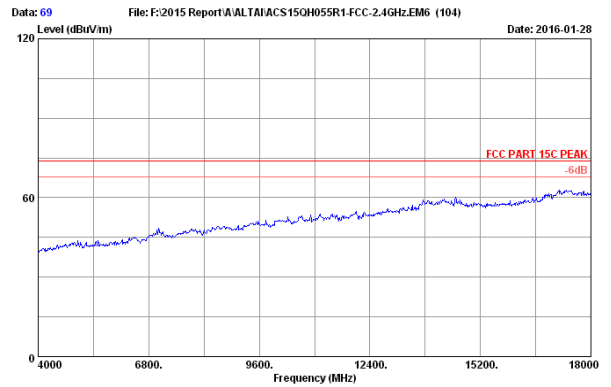

Site no. : 3m Chamber Data no. : 69
 Dis. / Ant. : 3m 2015 MCTD1209 3006 Ant. pol. : VERTICAL
 Limit : FCC PART 15C PEAK
 Env. / Ins. : 23°C/54%
 Engineer : Leo-Li
 EUT : Altai A8in (ac) Super WiFi Base Station
 Power rating : DC 56V From POE Input AC 120V/60Hz
 Test Mode : IEEE802.11nHT20 2412Hz Tx
 WA8011NAC-H

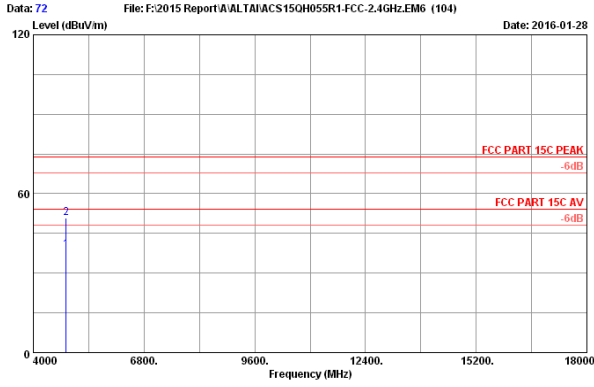

Site no. : 3m Chamber Data no. : 72
 Dis. / Ant. : 3m 2015 MCTD1209 3006 Ant. pol. : HORIZONTAL
 Limit : FCC PART 15C PEAK
 Env. / Ins. : 23°C/54%
 Engineer : Leo-Li
 EUT : Altai A8in (ac) Super WiFi Base Station
 Power rating : DC 56V From POE Input AC 120V/60Hz
 Test Mode : IEEE802.11nHT20 2412Hz Tx
 WA8011NAC-H

No.	Freq. (MHz)	Ant. Factor (dB/m)	Cable Loss (dB)	AMP factor (dB)	Reading (dBuV)	Emission Level (dBuV/m)	Limits (dBuV/m)	Margin (dB)	Remark
1	4824.000	33.72	9.46	35.53	31.26	38.91	54.00	15.09	Average
2	4824.000	33.72	9.46	35.53	43.26	50.91	74.00	23.09	Peak

Remarks: 1. Emission Level= Antenna Factor + Cable Loss + Reading - Amp Factor
 2. The emission levels that are 20dB below the official limit are not reported.

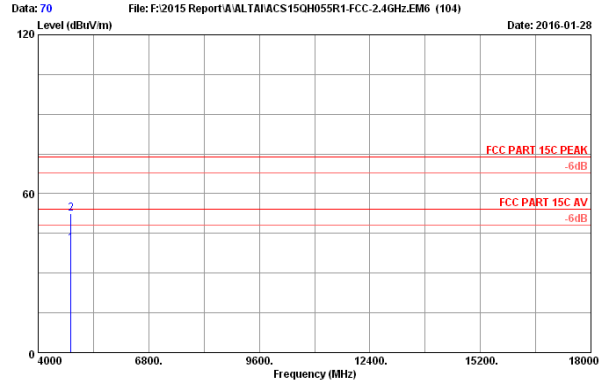

Site no. : 3m Chamber Data no. : 70
 Dis. / Ant. : 3m 2015 MCTD1209 3006 Ant. pol. : VERTICAL
 Limit : FCC PART 15C PEAK
 Env. / Ins. : 23°C/54%
 Engineer : Leo-Li
 EUT : Altai A8in (ac) Super WiFi Base Station
 Power rating : DC 56V From POE Input AC 120V/60Hz
 Test Mode : IEEE802.11nHT20 2412Hz Tx
 WA8011NAC-H

No.	Freq. (MHz)	Ant. Factor (dB/m)	Cable Loss (dB)	AMP factor (dB)	Reading (dBuV)	Emission Level (dBuV/m)	Limits (dBuV/m)	Margin (dB)	Remark
1	4824.000	33.72	9.46	35.53	33.41	41.06	54.00	12.94	Average
2	4824.000	33.72	9.46	35.53	44.84	52.49	74.00	21.51	Peak

Remarks: 1. Emission Level= Antenna Factor + Cable Loss + Reading - Amp Factor
 2. The emission levels that are 20dB below the official limit are not reported.

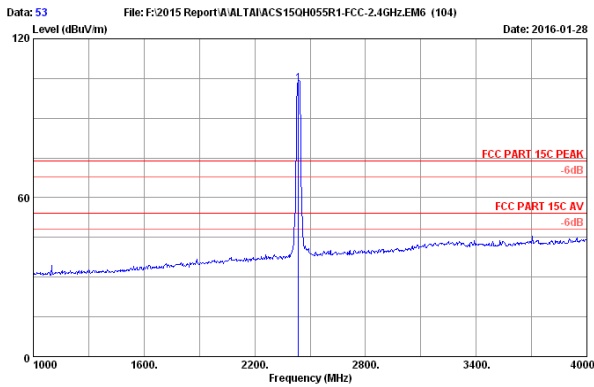

Site no. : 3m Chamber Data no. : 53
 Dis. / Ant. : 3m 2015 MCTD1209 3006 Ant. pol. : HORIZONTAL
 Limit : FCC PART 15C PEAK
 Env. / Ins. : 23°C/54%
 Engineer : Leo-Li
 EUT : Altai A8in (ac) Super WiFi Base Station
 Power rating : DC 56V From POE Input AC 120V/60Hz
 Test Mode : IEEE802.11nHT20 2437Hz Tx
 WA8011NAC-H

No.	Freq. (MHz)	Ant. Factor (dB/m)	Cable Loss (dB)	AMP factor (dB)	Reading (dBuV)	Emission Level (dBuV/m)	Limits (dBuV/m)	Margin (dB)	Remark
1	2437.000	28.07	7.39	36.61	104.24	103.09	74.00	-29.09	Peak

Remarks: 1. Emission Level= Antenna Factor + Cable Loss + Reading - Amp Factor
 2. The emission levels that are 20dB below the official limit are not reported.

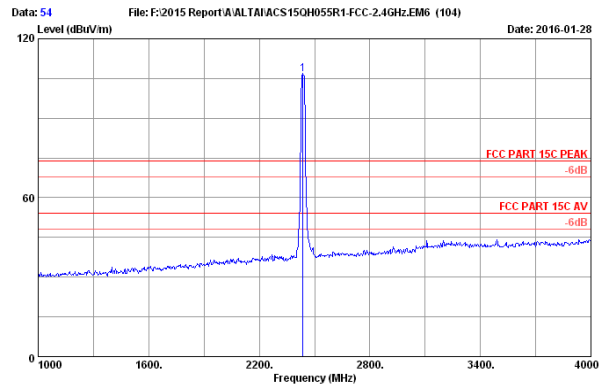

Site no. : 3m Chamber Data no. : 54
 Dis. / Ant. : 3m 2015 MCTD1209 3006 Ant. pol. : VERTICAL
 Limit : FCC PART 15C PEAK
 Env. / Ins. : 23°C/54%
 Engineer : Leo-Li
 EUT : Altai A8in (ac) Super WiFi Base Station
 Power rating : DC 56V From POE Input AC 120V/60Hz
 Test Mode : IEEE802.11nHT20 2437Hz Tx
 WA8011NAC-H

No.	Freq. (MHz)	Ant. Factor (dB/m)	Cable Loss (dB)	AMP factor (dB)	Reading (dBuV)	Emission Level (dBuV/m)	Limits (dBuV/m)	Margin (dB)	Remark
1	2437.000	28.07	7.39	36.61	107.62	106.47	74.00	-32.47	Peak

Remarks: 1. Emission Level= Antenna Factor + Cable Loss + Reading - Amp Factor
 2. The emission levels that are 20dB below the official limit are not reported.

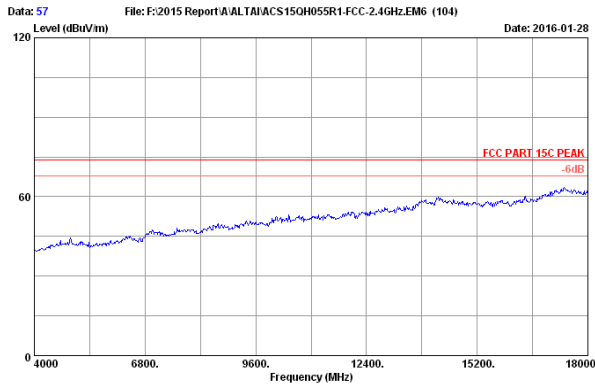

Site no. : 3m Chamber Data no. : 57
 Dis. / Ant. : 3m 2015 MCTD1209 3006 Ant. pol. : HORIZONTAL
 Limit : FCC PART 15C PEAK
 Env. / Ins. : 23°C/54%
 Engineer : Leo-Li
 EUT : Altai A8in (ac) Super WiFi Base Station
 Power rating : DC 56V From POE Input AC 120V/60Hz
 Test Mode : IEEE802.11nHT20 2437Hz Tx
 WA8011NAC-H

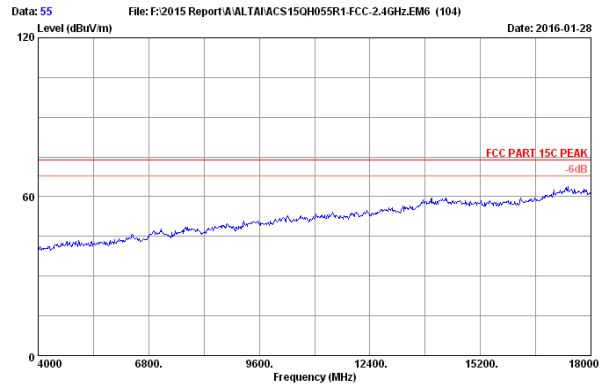

Site no. : 3m Chamber Data no. : 55
 Dis. / Ant. : 3m 2015 MCTD1209 3006 Ant. pol. : VERTICAL
 Limit : FCC PART 15C PEAK
 Env. / Ins. : 23°C/54%
 Engineer : Leo-Li
 EUT : Altai A8in (ac) Super WiFi Base Station
 Power rating : DC 56V From POE Input AC 120V/60Hz
 Test Mode : IEEE802.11nHT20 2437Hz Tx
 WA8011NAC-H

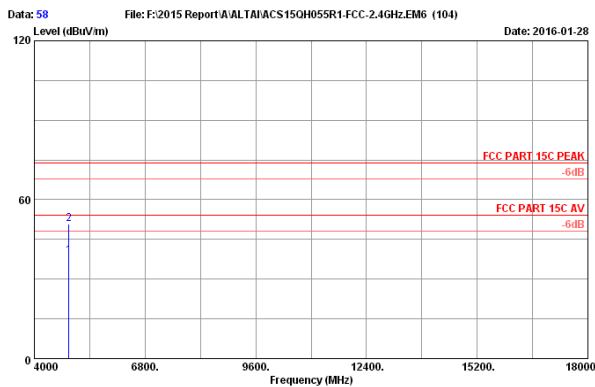

Site no. : 3m Chamber Data no. : 58
 Dis. / Ant. : 3m 2015 MCTD1209 3006 Ant. pol. : HORIZONTAL
 Limit : FCC PART 15C PEAK
 Env. / Ins. : 23°C/54%
 Engineer : Leo-Li
 EUT : Altai A8in (ac) Super WiFi Base Station
 Power rating : DC 56V From POE Input AC 120V/60Hz
 Test Mode : IEEE802.11nHT20 2437Hz Tx
 WA8011NAC-H

No.	Freq. (MHz)	Ant. Factor (dB/m)	Cable Loss (dB)	AMP factor (dB)	Reading (dBuV)	Emission Level (dBuV/m)	Limits (dBuV/m)	Margin (dB)	Remark
1	4874.000	33.80	9.49	35.51	31.06	38.84	54.00	15.16	Average
2	4874.000	33.80	9.49	35.51	42.89	50.67	74.00	23.33	Peak

Remarks: 1. Emission Level= Antenna Factor + Cable Loss + Reading - Amp Factor
 2. The emission levels that are 20dB below the official limit are not reported.

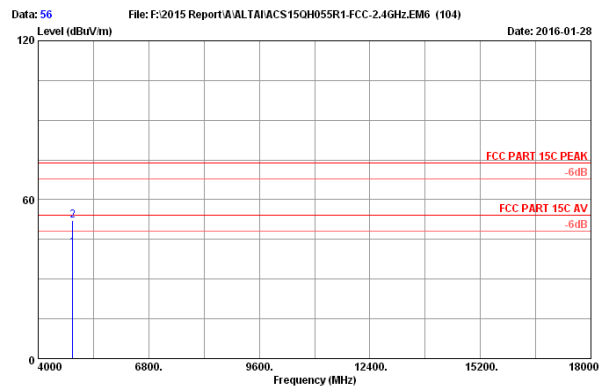

Site no. : 3m Chamber Data no. : 56
 Dis. / Ant. : 3m 2015 MCTD1209 3006 Ant. pol. : VERTICAL
 Limit : FCC PART 15C PEAK
 Env. / Ins. : 23°C/54%
 Engineer : Leo-Li
 EUT : Altai A8in (ac) Super WiFi Base Station
 Power rating : DC 56V From POE Input AC 120V/60Hz
 Test Mode : IEEE802.11nHT20 2437Hz Tx
 WA8011NAC-H

No.	Freq. (MHz)	Ant. Factor (dB/m)	Cable Loss (dB)	AMP factor (dB)	Reading (dBuV)	Emission Level (dBuV/m)	Limits (dBuV/m)	Margin (dB)	Remark
1	4874.000	33.80	9.49	35.51	33.84	41.62	54.00	12.38	Average
2	4874.000	33.80	9.49	35.51	44.26	52.04	74.00	21.96	Peak

Remarks: 1. Emission Level= Antenna Factor + Cable Loss + Reading - Amp Factor
 2. The emission levels that are 20dB below the official limit are not reported.

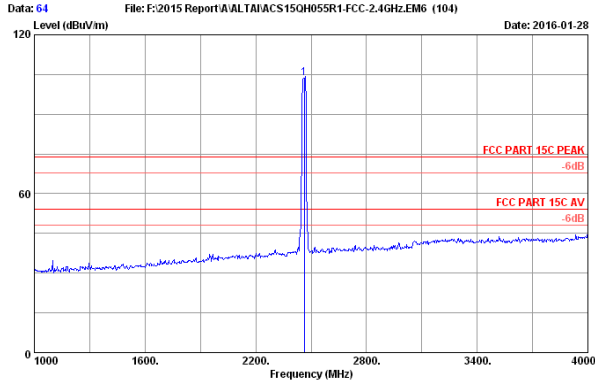

Site no. : 3m Chamber Data no. : 64
 Dis. / Ant. : 3m 2015 MCTD1209 3006 Ant. pol. : HORIZONTAL
 Limit : FCC PART 15C PEAK
 Env. / Ins. : 23°C/54%
 Engineer : Leo-Li
 EUT : Altai A8in (ac) Super WiFi Base Station
 Power rating : DC 56V From POE Input AC 120V/60Hz
 Test Mode : IEEE802.11nHT20 2462Hz Tx
 WA8011NAC-H

No.	Freq. (MHz)	Ant. Factor (dB/m)	Cable Loss (dB)	AMP factor (dB)	Reading (dBuV)	Emission Level (dBuV/m)	Limits (dBuV/m)	Margin (dB)	Remark
1	2462.000	28.12	7.43	36.60	104.67	103.62	74.00	-29.62	Peak

Remarks: 1. Emission Level= Antenna Factor + Cable Loss + Reading - Amp Factor
 2. The emission levels that are 20dB below the official limit are not reported.

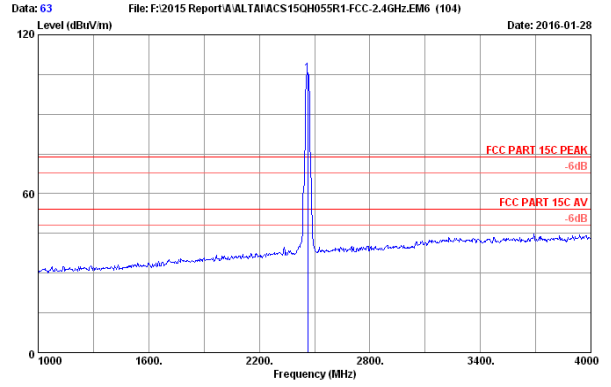

Site no. : 3m Chamber Data no. : 63
 Dis. / Ant. : 3m 2015 MCTD1209 3006 Ant. pol. : VERTICAL
 Limit : FCC PART 15C PEAK
 Env. / Ins. : 23°C/54%
 Engineer : Leo-Li
 EUT : Altai A8in (ac) Super WiFi Base Station
 Power rating : DC 56V From POE Input AC 120V/60Hz
 Test Mode : IEEE802.11nHT20 2462Hz Tx
 WA8011NAC-H

No.	Freq. (MHz)	Ant. Factor (dB/m)	Cable Loss (dB)	AMP factor (dB)	Reading (dBuV)	Emission Level (dBuV/m)	Limits (dBuV/m)	Margin (dB)	Remark
1	2462.000	28.12	7.43	36.60	106.27	105.22	74.00	-31.22	Peak

Remarks: 1. Emission Level= Antenna Factor + Cable Loss + Reading - Amp Factor
 2. The emission levels that are 20dB below the official limit are not reported.

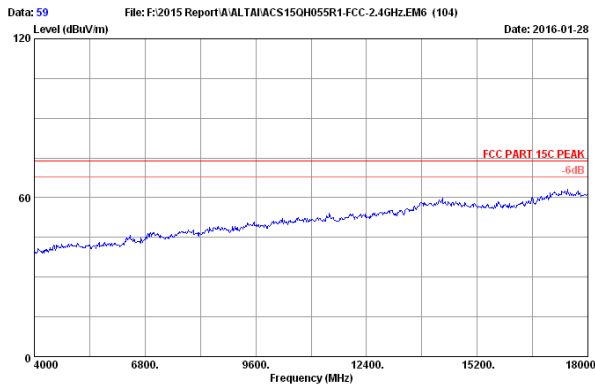

Site no. : 3m Chamber Data no. : 59
 Dis. / Ant. : 3m 2015 MCTD1209 3006 Ant. pol. : HORIZONTAL
 Limit : FCC PART 15C PEAK
 Env. / Ins. : 23°C/54%
 Engineer : Leo-Li
 EUT : Altai A8in (ac) Super WiFi Base Station
 Power rating : DC 56V From POE Input AC 120V/60Hz
 Test Mode : IEEE802.11nHT20 2462Hz Tx
 WA8011NAC-H

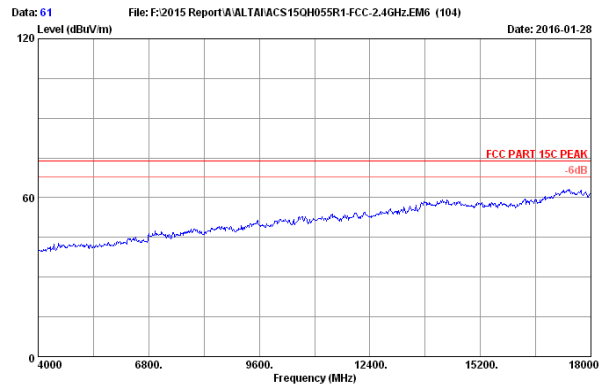

Site no. : 3m Chamber Data no. : 61
 Dis. / Ant. : 3m 2015 MCTD1209 3006 Ant. pol. : VERTICAL
 Limit : FCC PART 15C PEAK
 Env. / Ins. : 23°C/54%
 Engineer : Leo-Li
 EUT : Altai A8in (ac) Super WiFi Base Station
 Power rating : DC 56V From POE Input AC 120V/60Hz
 Test Mode : IEEE802.11nHT20 2462Hz Tx
 WA8011NAC-H

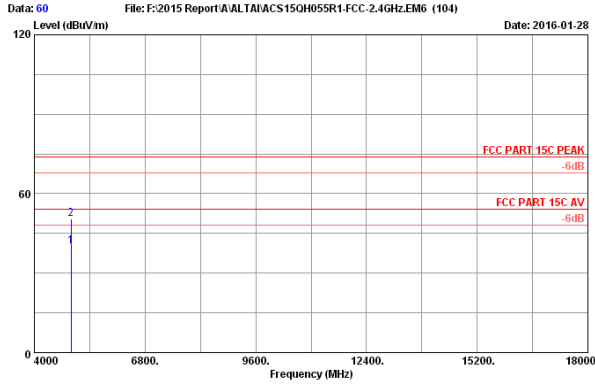

Site no. : 3m Chamber Data no. : 60
 Dis. / Ant. : 3m 2015 MCTD1209 3006 Ant. pol. : HORIZONTAL
 Limit : FCC PART 15C PEAK
 Env. / Ins. : 23°C/54%
 Engineer : Leo-Li
 EUT : Altai A8in (ac) Super WiFi Base Station
 Power rating : DC 56V From POE Input AC 120V/60Hz
 Test Mode : IEEE802.11nHT20 2462Hz Tx
 WA8011NAC-H

No.	Freq. (MHz)	Ant. Factor (dB/m)	Cable Loss (dB)	AMP factor (dB)	Reading (dBuV)	Emission Level (dBuV/m)	Limits (dBuV/m)	Margin (dB)	Remark
1	4924.000	33.88	9.51	35.48	32.04	39.95	54.00	14.05	Average
2	4924.000	33.88	9.51	35.48	42.68	50.59	74.00	23.41	Peak

Remarks: 1. Emission Level= Antenna Factor + Cable Loss + Reading - Amp Factor
 2. The emission levels that are 20dB below the official limit are not reported.

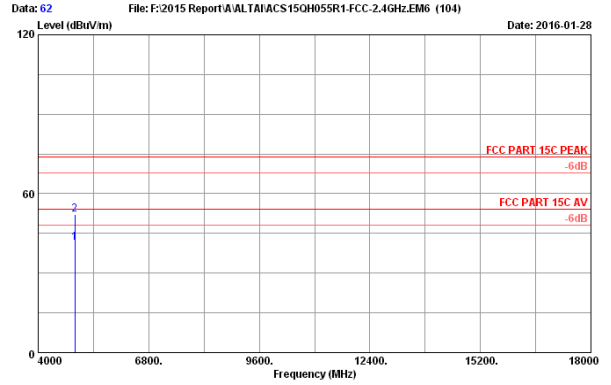

Site no. : 3m Chamber Data no. : 62
 Dis. / Ant. : 3m 2015 MCTD1209 3006 Ant. pol. : VERTICAL
 Limit : FCC PART 15C PEAK
 Env. / Ins. : 23°C/54%
 Engineer : Leo-Li
 EUT : Altai A8in (ac) Super WiFi Base Station
 Power rating : DC 56V From POE Input AC 120V/60Hz
 Test Mode : IEEE802.11nHT20 2462Hz Tx
 WA8011NAC-H

No.	Freq. (MHz)	Ant. Factor (dB/m)	Cable Loss (dB)	AMP factor (dB)	Reading (dBuV)	Emission Level (dBuV/m)	Limits (dBuV/m)	Margin (dB)	Remark
1	4924.000	33.88	9.51	35.48	33.44	41.35	54.00	12.65	Average
2	4924.000	33.88	9.51	35.48	44.17	52.08	74.00	21.92	Peak

Remarks: 1. Emission Level= Antenna Factor + Cable Loss + Reading - Amp Factor
 2. The emission levels that are 20dB below the official limit are not reported.

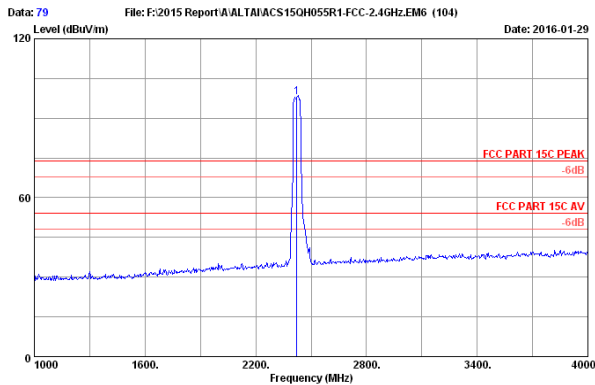

Site no. : 3m Chamber Data no. : 79
 Dis. / Ant. : 3m 2015 MCTD1209 3006 Ant. pol. : HORIZONTAL
 Limit : FCC PART 15C PEAK
 Env. / Ins. : 23°C/54%
 Engineer : Leo-Li
 EUT : Altai A8in (ac) Super WiFi Base Station
 Power rating : DC 56V From POE Input AC 120V/60Hz
 Test Mode : IEEE802.11nHT40 2422Hz Tx
 WA8011NAC-H

No.	Freq. (MHz)	Ant. Factor (dB/m)	Cable Loss (dB)	AMP factor (dB)	Reading (dBuV)	Emission Level (dBuV/m)	Limits (dBuV/m)	Margin (dB)	Remark
1	2422.000	28.04	7.35	36.61	99.27	98.05	74.00	-24.05	Peak

Remarks: 1. Emission Level= Antenna Factor + Cable Loss + Reading - Amp Factor
 2. The emission levels that are 20dB below the official limit are not reported.

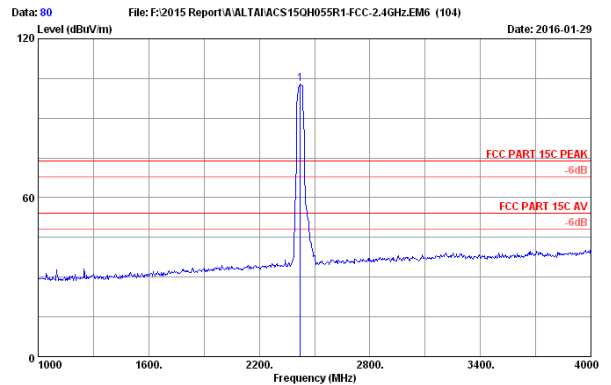

Site no. : 3m Chamber Data no. : 80
 Dis. / Ant. : 3m 2015 MCTD1209 3006 Ant. pol. : VERTICAL
 Limit : FCC PART 15C PEAK
 Env. / Ins. : 23°C/54%
 Engineer : Leo-Li
 EUT : Altai A8in (ac) Super WiFi Base Station
 Power rating : DC 56V From POE Input AC 120V/60Hz
 Test Mode : IEEE802.11nHT40 2422Hz Tx
 WA8011NAC-H

No.	Freq. (MHz)	Ant. Factor (dB/m)	Cable Loss (dB)	AMP factor (dB)	Reading (dBuV)	Emission Level (dBuV/m)	Limits (dBuV/m)	Margin (dB)	Remark
1	2422.000	28.04	7.35	36.61	104.27	103.05	74.00	-29.05	Peak

Remarks: 1. Emission Level= Antenna Factor + Cable Loss + Reading - Amp Factor
 2. The emission levels that are 20dB below the official limit are not reported.

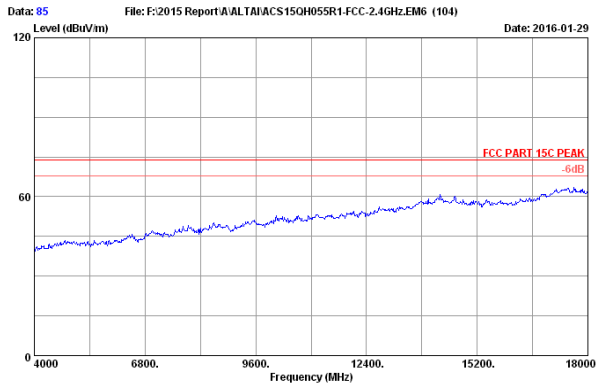

Site no. : 3m Chamber Data no. : 85
 Dis. / Ant. : 3m 2015 MCTD1209 3006 Ant. pol. : HORIZONTAL
 Limit : FCC PART 15C PEAK
 Env. / Ins. : 23°C/54%
 Engineer : Leo-Li
 EUT : Altai A8in (ac) Super WiFi Base Station
 Power rating : DC 56V From POE Input AC 120V/60Hz
 Test Mode : IEEE802.11nHT40 2422Hz Tx
 WA8011NAC-H

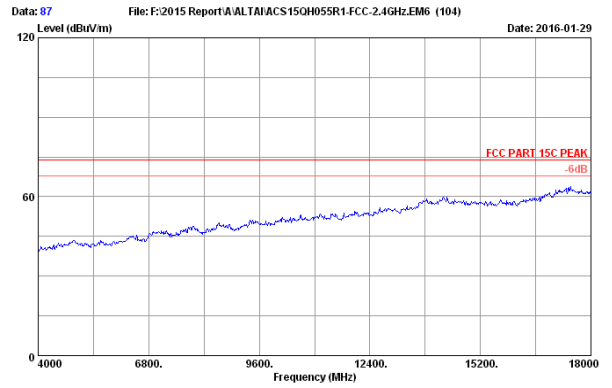

Site no. : 3m Chamber Data no. : 87
 Dis. / Ant. : 3m 2015 MCTD1209 3006 Ant. pol. : VERTICAL
 Limit : FCC PART 15C PEAK
 Env. / Ins. : 23°C/54%
 Engineer : Leo-Li
 EUT : Altai A8in (ac) Super WiFi Base Station
 Power rating : DC 56V From POE Input AC 120V/60Hz
 Test Mode : IEEE802.11nHT40 2422Hz Tx
 WA8011NAC-H

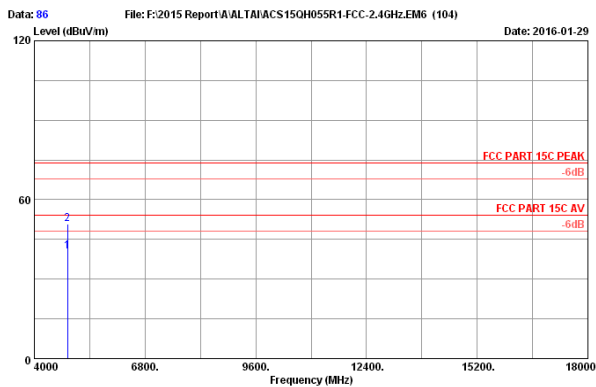

Site no. : 3m Chamber Data no. : 86
 Dis. / Ant. : 3m 2015 MCTD1209 3006 Ant. pol. : HORIZONTAL
 Limit : FCC PART 15C PEAK
 Env. / Ins. : 23°C/54%
 Engineer : Leo-Li
 EUT : Altai A8in (ac) Super WiFi Base Station
 Power rating : DC 56V From POE Input AC 120V/60Hz
 Test Mode : IEEE802.11nHT40 2422Hz Tx
 WA8011NAC-H

No.	Freq. (MHz)	Ant. Factor (dB/m)	Cable Loss (dB)	AMP factor (dB)	Reading (dBuV)	Emission Level (dBuV/m)	Limits (dBuV/m)	Margin (dB)	Remark
1	4844.000	33.75	9.47	35.52	32.66	40.36	54.00	13.64	Average
2	4844.000	33.75	9.47	35.52	43.17	50.87	74.00	23.13	Peak

Remarks: 1. Emission Level= Antenna Factor + Cable Loss + Reading - Amp Factor
 2. The emission levels that are 20dB below the official limit are not reported.

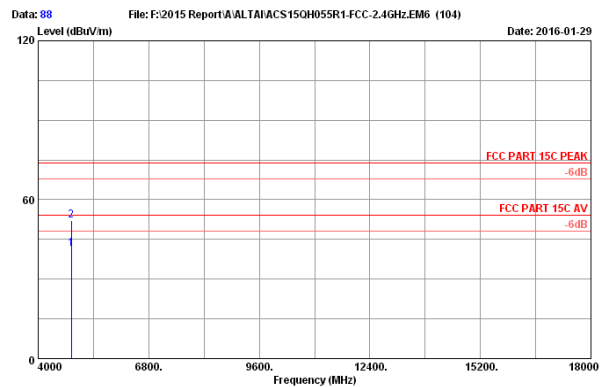

Site no. : 3m Chamber Data no. : 88
 Dis. / Ant. : 3m 2015 MCTD1209 3006 Ant. pol. : VERTICAL
 Limit : FCC PART 15C PEAK
 Env. / Ins. : 23°C/54%
 Engineer : Leo-Li
 EUT : Altai A8in (ac) Super WiFi Base Station
 Power rating : DC 56V From POE Input AC 120V/60Hz
 Test Mode : IEEE802.11nHT40 2422Hz Tx
 WA8011NAC-H

No.	Freq. (MHz)	Ant. Factor (dB/m)	Cable Loss (dB)	AMP factor (dB)	Reading (dBuV)	Emission Level (dBuV/m)	Limits (dBuV/m)	Margin (dB)	Remark
1	4844.000	33.75	9.47	35.52	33.68	41.38	54.00	12.62	Average
2	4844.000	33.75	9.47	35.52	44.58	52.28	74.00	21.72	Peak

Remarks: 1. Emission Level= Antenna Factor + Cable Loss + Reading - Amp Factor
 2. The emission levels that are 20dB below the official limit are not reported.

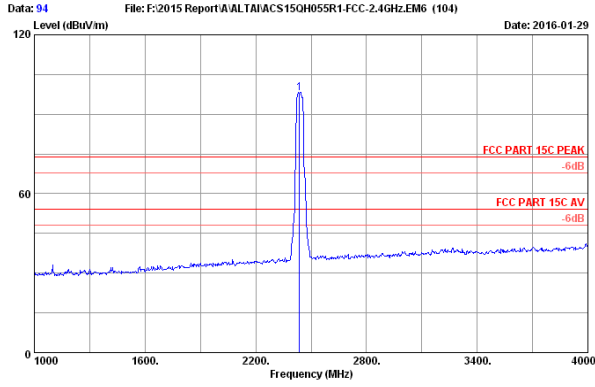

Site no. : 3m Chamber Data no. : 94
 Dis. / Ant. : 3m 2015 MCTD1209 3006 Ant. pol. : HORIZONTAL
 Limit : FCC PART 15C PEAK
 Env. / Ins. : 23°C/54%
 Engineer : Leo-Li
 EUT : Altai A8in (ac) Super WiFi Base Station
 Power rating : DC 56V From POE Input AC 120V/60Hz
 Test Mode : IEEE802.11nHT40 2437Hz Tx
 WA8011NAC-H

No.	Freq. (MHz)	Ant. Factor (dB/m)	Cable Loss (dB)	AMP factor (dB)	Reading (dBuV)	Emission Level (dBuV/m)	Limits (dBuV/m)	Margin (dB)	Remark
1	2437.000	28.07	7.39	36.61	98.96	97.81	74.00	-23.81	Peak

Remarks: 1. Emission Level= Antenna Factor + Cable Loss + Reading - Amp Factor
 2. The emission levels that are 20dB below the official limit are not reported.

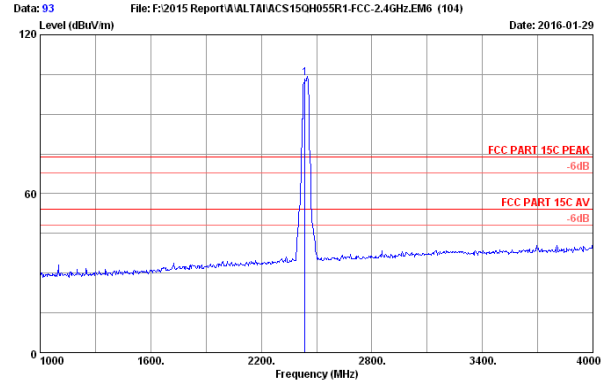

Site no. : 3m Chamber Data no. : 93
 Dis. / Ant. : 3m 2015 MCTD1209 3006 Ant. pol. : VERTICAL
 Limit : FCC PART 15C PEAK
 Env. / Ins. : 23°C/54%
 Engineer : Leo-Li
 EUT : Altai A8in (ac) Super WiFi Base Station
 Power rating : DC 56V From POE Input AC 120V/60Hz
 Test Mode : IEEE802.11nHT40 2437Hz Tx
 WA8011NAC-H

No.	Freq. (MHz)	Ant. Factor (dB/m)	Cable Loss (dB)	AMP factor (dB)	Reading (dBuV)	Emission Level (dBuV/m)	Limits (dBuV/m)	Margin (dB)	Remark
1	2437.000	28.07	7.39	36.61	104.66	103.51	74.00	-29.51	Peak

Remarks: 1. Emission Level= Antenna Factor + Cable Loss + Reading - Amp Factor
 2. The emission levels that are 20dB below the official limit are not reported.

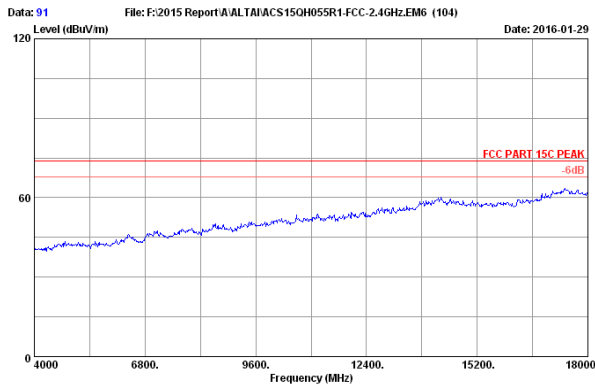

Site no. : 3m Chamber Data no. : 91
 Dis. / Ant. : 3m 2015 MCTD1209 3006 Ant. pol. : HORIZONTAL
 Limit : FCC PART 15C PEAK
 Env. / Ins. : 23°C/54%
 Engineer : Leo-Li
 EUT : Altai A8in (ac) Super WiFi Base Station
 Power rating : DC 56V From POE Input AC 120V/60Hz
 Test Mode : IEEE802.11nHT40 2437Hz Tx
 WA8011NAC-H

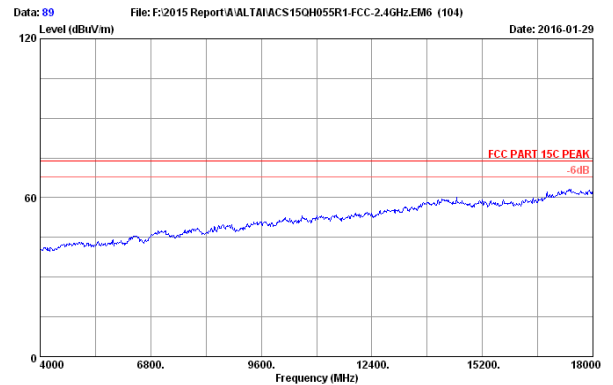

Site no. : 3m Chamber Data no. : 89
 Dis. / Ant. : 3m 2015 MCTD1209 3006 Ant. pol. : VERTICAL
 Limit : FCC PART 15C PEAK
 Env. / Ins. : 23°C/54%
 Engineer : Leo-Li
 EUT : Altai A8in (ac) Super WiFi Base Station
 Power rating : DC 56V From POE Input AC 120V/60Hz
 Test Mode : IEEE802.11nHT40 2437Hz Tx
 WA8011NAC-H

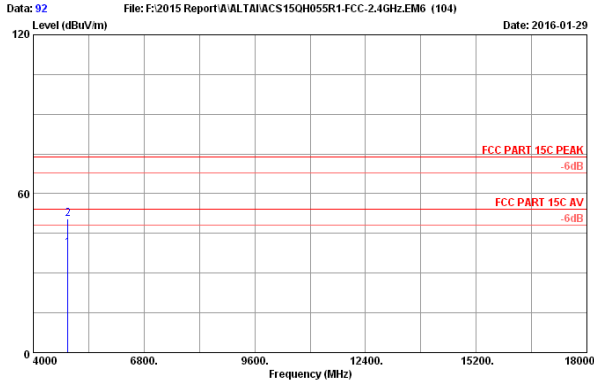

Site no. : 3m Chamber Data no. : 92
 Dis. / Ant. : 3m 2015 MCTD1209 3006 Ant. pol. : HORIZONTAL
 Limit : FCC PART 15C PEAK
 Env. / Ins. : 23°C/54%
 Engineer : Leo-Li
 EUT : Altai A8in (ac) Super WiFi Base Station
 Power rating : DC 56V From POE Input AC 120V/60Hz
 Test Mode : IEEE802.11nHT40 2437Hz Tx
 WA8011NAC-H

No.	Freq. (MHz)	Ant. Factor (dB/m)	Cable Loss (dB)	AMP factor (dB)	Reading (dBuV)	Emission Level (dBuV/m)	Limits (dBuV/m)	Margin (dB)	Remark
1	4874.000	33.80	9.49	35.51	31.59	39.37	54.00	14.63	Average
2	4874.000	33.80	9.49	35.51	42.58	50.36	74.00	23.64	Peak

Remarks: 1. Emission Level= Antenna Factor + Cable Loss + Reading - Amp Factor
 2. The emission levels that are 20dB below the official limit are not reported.

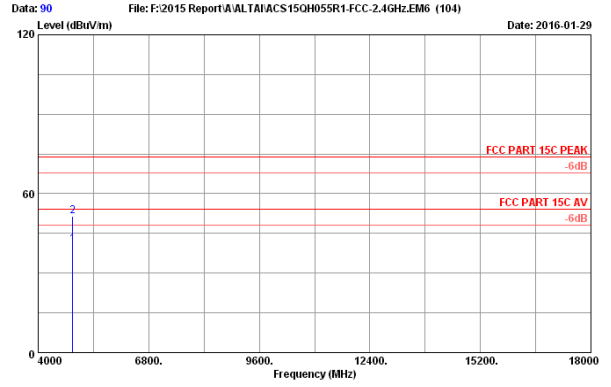

Site no. : 3m Chamber Data no. : 90
 Dis. / Ant. : 3m 2015 MCTD1209 3006 Ant. pol. : VERTICAL
 Limit : FCC PART 15C PEAK
 Env. / Ins. : 23°C/54%
 Engineer : Leo-Li
 EUT : Altai A8in (ac) Super WiFi Base Station
 Power rating : DC 56V From POE Input AC 120V/60Hz
 Test Mode : IEEE802.11nHT40 2437Hz Tx
 WA8011NAC-H

No.	Freq. (MHz)	Ant. Factor (dB/m)	Cable Loss (dB)	AMP factor (dB)	Reading (dBuV)	Emission Level (dBuV/m)	Limits (dBuV/m)	Margin (dB)	Remark
1	4874.000	33.80	9.49	35.51	32.89	40.67	74.00	33.33	Average
2	4874.000	33.80	9.49	35.51	43.68	51.46	74.00	22.54	Peak

Remarks: 1. Emission Level= Antenna Factor + Cable Loss + Reading - Amp Factor
 2. The emission levels that are 20dB below the official limit are not reported.

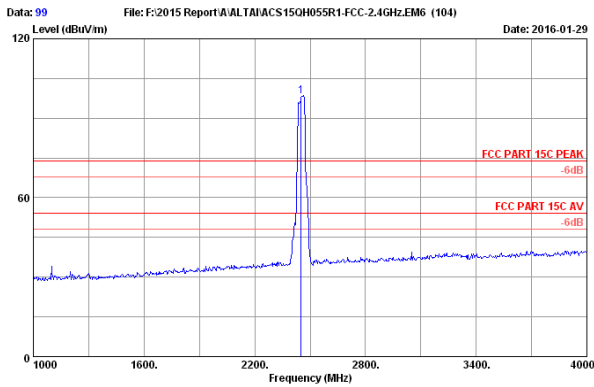

Site no. : 3m Chamber Data no. : 99
 Dis. / Ant. : 3m 2015 MCTD1209 3006 Ant. pol. : HORIZONTAL
 Limit : FCC PART 15C PEAK
 Env. / Ins. : 23°C/54%
 Engineer : Leo-Li
 EUT : Altai A8in (ac) Super WiFi Base Station
 Power rating : DC 56V From POE Input AC 120V/60Hz
 Test Mode : IEEE802.11nHT40 2452Hz Tx
 WA8011NAC-H

No.	Freq. (MHz)	Ant. Factor (dB/m)	Cable Loss (dB)	AMP factor (dB)	Reading (dBuV)	Emission Level (dBuV/m)	Limits (dBuV/m)	Margin (dB)	Remark
1	2452.000	28.10	7.43	36.60	99.40	98.33	74.00	-24.33	Peak

Remarks: 1. Emission Level= Antenna Factor + Cable Loss + Reading - Amp Factor
 2. The emission levels that are 20dB below the official limit are not reported.

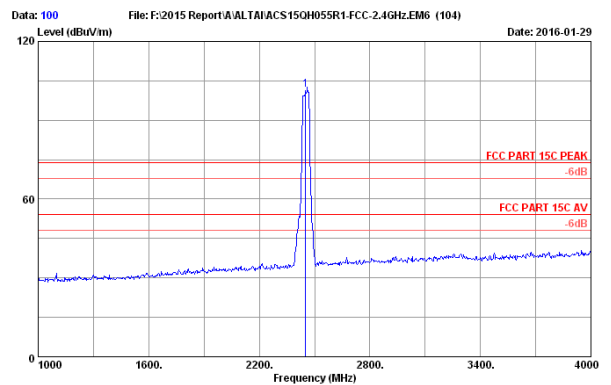

Site no. : 3m Chamber Data no. : 100
 Dis. / Ant. : 3m 2015 MCTD1209 3006 Ant. pol. : VERTICAL
 Limit : FCC PART 15C PEAK
 Env. / Ins. : 23°C/54%
 Engineer : Leo-Li
 EUT : Altai A8in (ac) Super WiFi Base Station
 Power rating : DC 56V From POE Input AC 120V/60Hz
 Test Mode : IEEE802.11nHT40 2452Hz Tx
 WA8011NAC-H

No.	Freq. (MHz)	Ant. Factor (dB/m)	Cable Loss (dB)	AMP factor (dB)	Reading (dBuV)	Emission Level (dBuV/m)	Limits (dBuV/m)	Margin (dB)	Remark
1	2452.000	28.10	7.43	36.60	102.53	101.46	74.00	-27.46	Peak

Remarks: 1. Emission Level= Antenna Factor + Cable Loss + Reading - Amp Factor
 2. The emission levels that are 20dB below the official limit are not reported.

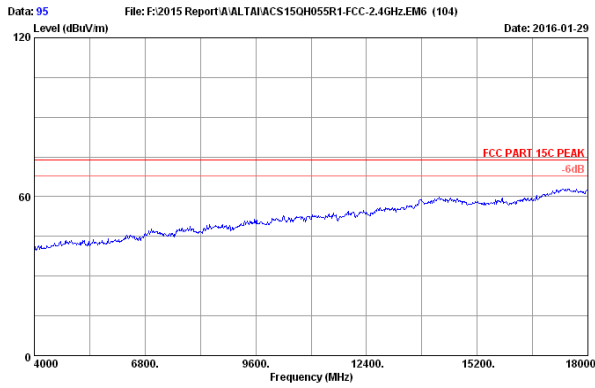

Site no. : 3m Chamber Data no. : 95
 Dis. / Ant. : 3m 2015 MCTD1209 3006 Ant. pol. : HORIZONTAL
 Limit : FCC PART 15C PEAK
 Env. / Ins. : 23°C/54%
 Engineer : Leo-Li
 EUT : Altai A8in (ac) Super WiFi Base Station
 Power rating : DC 56V From POE Input AC 120V/60Hz
 Test Mode : IEEE802.11nHT40 2452Hz Tx
 WA8011NAC-H

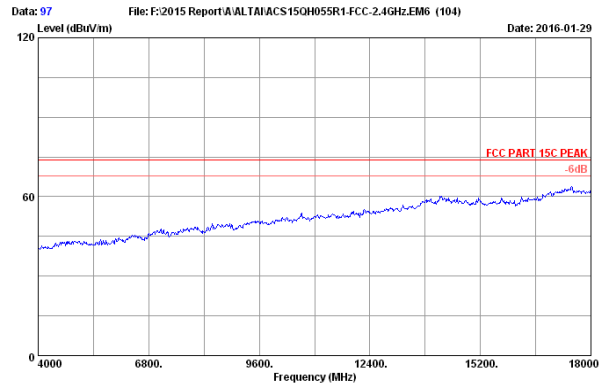

Site no. : 3m Chamber Data no. : 97
 Dis. / Ant. : 3m 2015 MCTD1209 3006 Ant. pol. : VERTICAL
 Limit : FCC PART 15C PEAK
 Env. / Ins. : 23°C/54%
 Engineer : Leo-Li
 EUT : Altai A8in (ac) Super WiFi Base Station
 Power rating : DC 56V From POE Input AC 120V/60Hz
 Test Mode : IEEE802.11nHT40 2452Hz Tx
 WA8011NAC-H

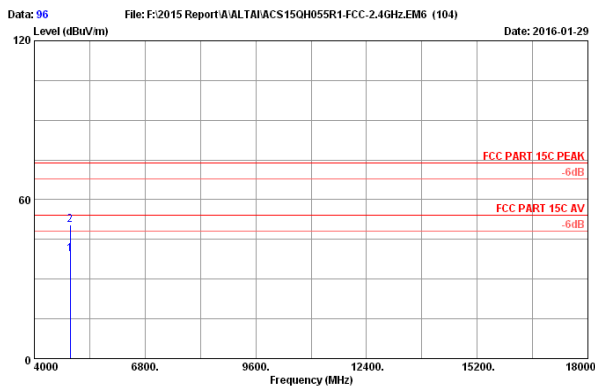

Site no. : 3m Chamber Data no. : 96
 Dis. / Ant. : 3m 2015 MCTD1209 3006 Ant. pol. : HORIZONTAL
 Limit : FCC PART 15C PEAK
 Env. / Ins. : 23°C/54%
 Engineer : Leo-Li
 EUT : Altai A8in (ac) Super WiFi Base Station
 Power rating : DC 56V From POE Input AC 120V/60Hz
 Test Mode : IEEE802.11nHT40 2452Hz Tx
 WA8011NAC-H

No.	Freq. (MHz)	Ant. Factor (dB/m)	Cable Loss (dB)	AMP factor (dB)	Reading (dBuV)	Emission Level (dBuV/m)	Limits (dBuV/m)	Margin (dB)	Remark
1	4904.000	33.85	9.50	35.50	31.69	39.54	54.00	14.46	Average
2	4904.000	33.85	9.50	35.50	42.59	50.44	74.00	23.56	Peak

Remarks: 1. Emission Level= Antenna Factor + Cable Loss + Reading - Amp Factor
 2. The emission levels that are 20dB below the official limit are not reported.

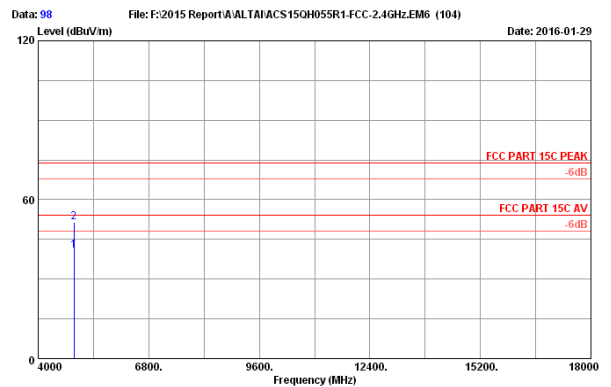

Site no. : 3m Chamber Data no. : 98
 Dis. / Ant. : 3m 2015 MCTD1209 3006 Ant. pol. : VERTICAL
 Limit : FCC PART 15C PEAK
 Env. / Ins. : 23°C/54%
 Engineer : Leo-Li
 EUT : Altai A8in (ac) Super WiFi Base Station
 Power rating : DC 56V From POE Input AC 120V/60Hz
 Test Mode : IEEE802.11nHT40 2452Hz Tx
 WA8011NAC-H

No.	Freq. (MHz)	Ant. Factor (dB/m)	Cable Loss (dB)	AMP factor (dB)	Reading (dBuV)	Emission Level (dBuV/m)	Limits (dBuV/m)	Margin (dB)	Remark
1	4904.000	33.85	9.50	35.50	33.07	40.92	54.00	13.08	Average
2	4904.000	33.85	9.50	35.50	43.68	51.53	74.00	22.47	Peak

Remarks: 1. Emission Level= Antenna Factor + Cable Loss + Reading - Amp Factor
 2. The emission levels that are 20dB below the official limit are not reported.

5. CONDUCTED SPURIOUS EMISSIONS

5.1. Test Equipment

Item	Equipment	Manufacturer	Model No.	Serial No.	Last Cal.	Cal. Interval
1.	Spectrum	Agilent	N9030A	MY51380221	Oct.17,15	1 Year
2.	Attenuator (20dB)	Agilent	8491B	MY39262165	Apr.28,15	1 Year
3.	RF Cable	Marvelous Microwave Inc	SFL402105FLEX	NO.1	Oct.17,15	1 Year

5.2. Limit

In any 100kHz bandwidth outside the frequency bands in which the spread spectrum intentional radiator is operating, the radio frequency power that is produced by the intentional radiator shall be at least 20dB below that in the 100kHz bandwidth within the band that contains the highest level of the desired power.

5.3. Test Procedure

The transmitter output was connected to a spectrum analyzer, The resolution bandwidth is set to 100 kHz, The video bandwidth is set to 300 kHz and measure all the emissions with peak detector.

5.4. Test result

PASS (The testing data was attached in the next pages.)

ANT1:

Test Mode: IEEE 802.11b
 Test CH1: 2412MHz

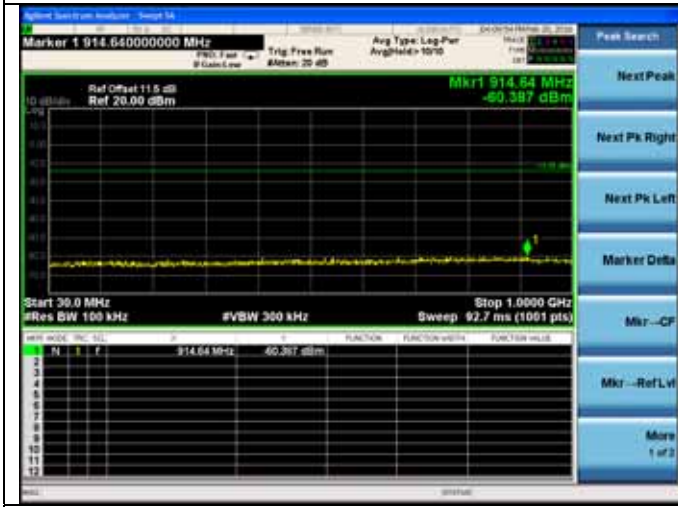

Test CH6: 2437MHz

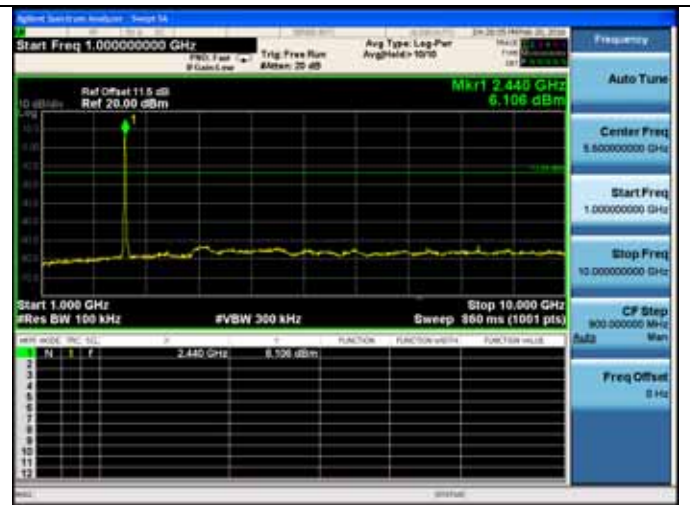
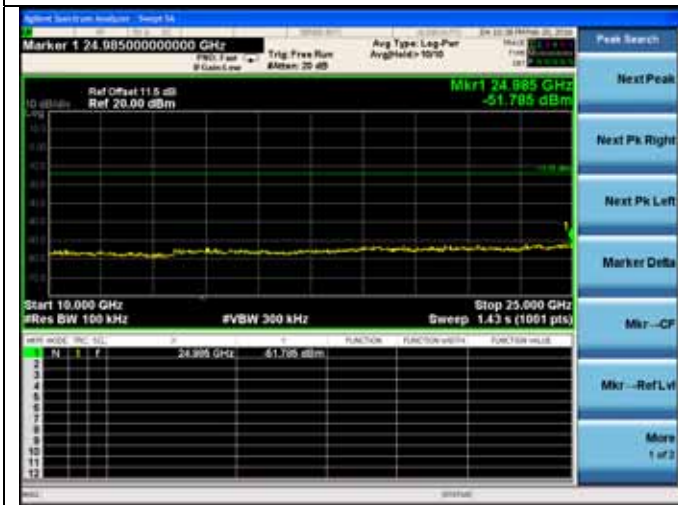
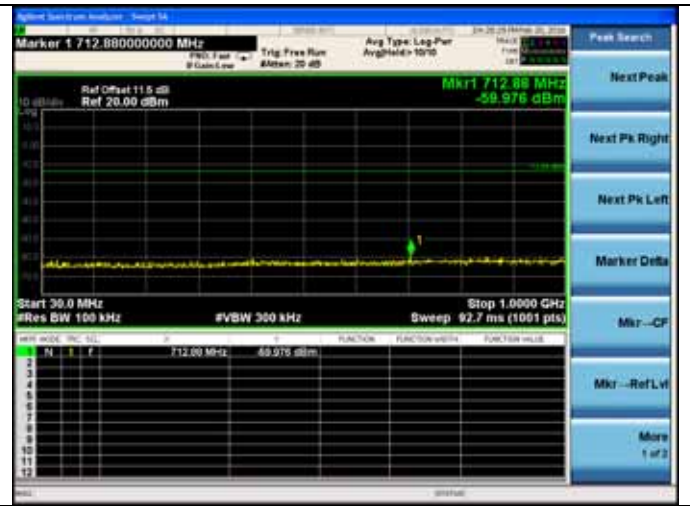
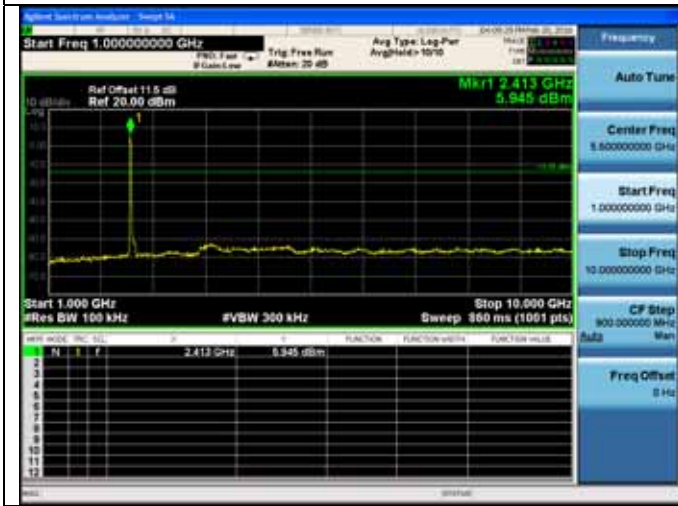

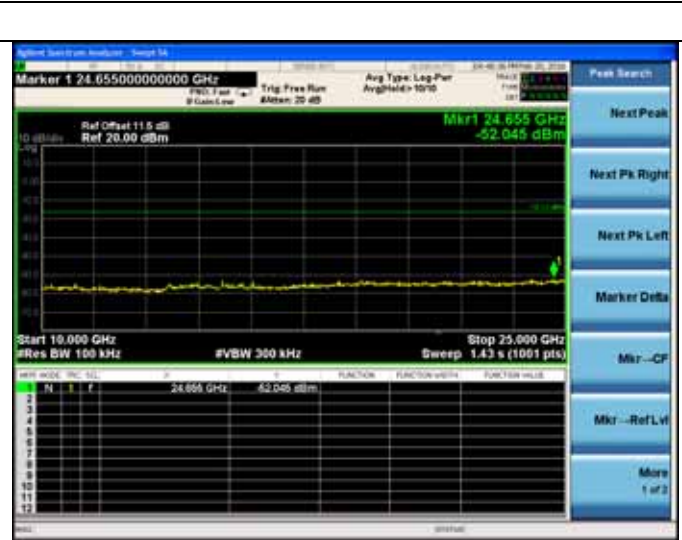
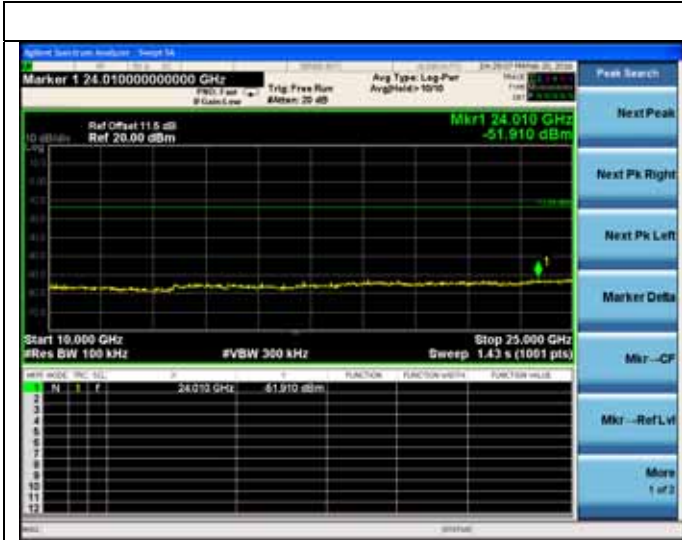

Test CH11: 2462MHz

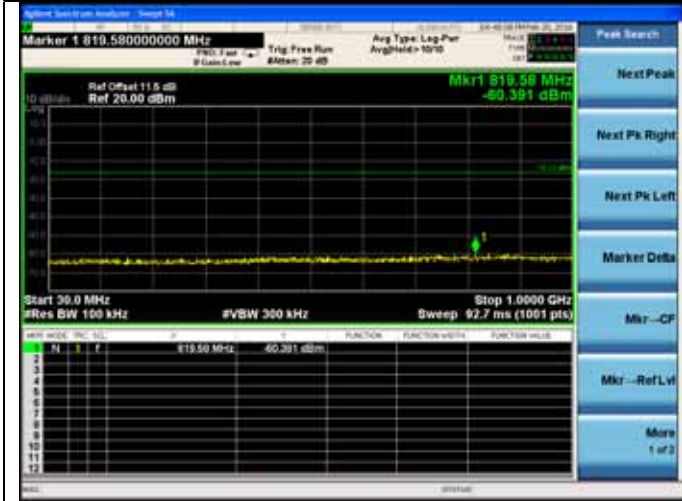

Test Mode: IEEE 802.11g
 Test CH1: 2412MHz

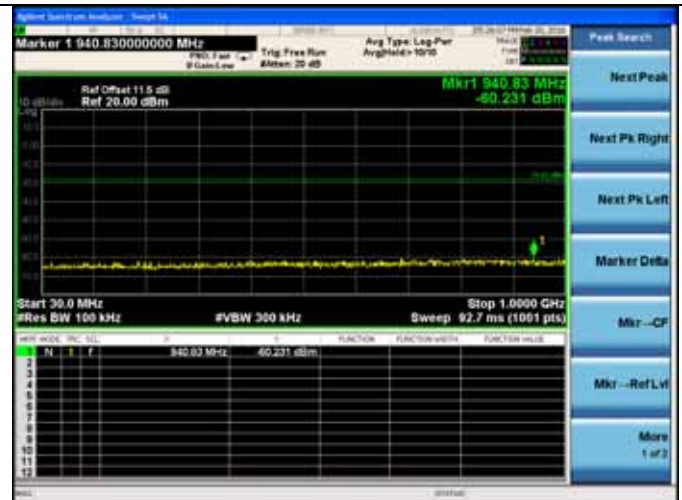
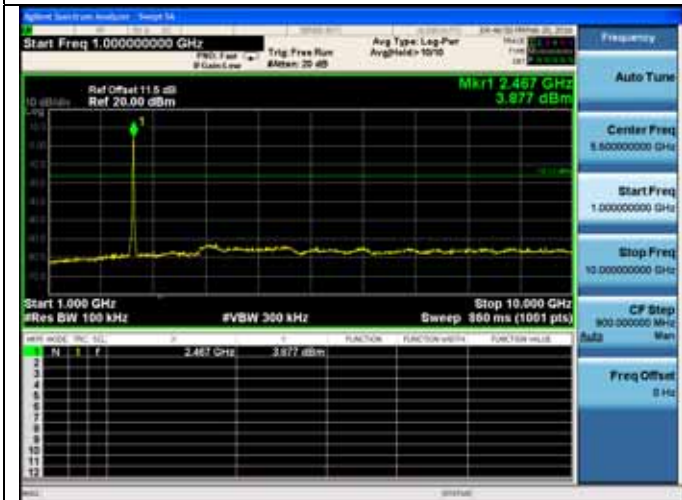

Test CH6: 2437MHz

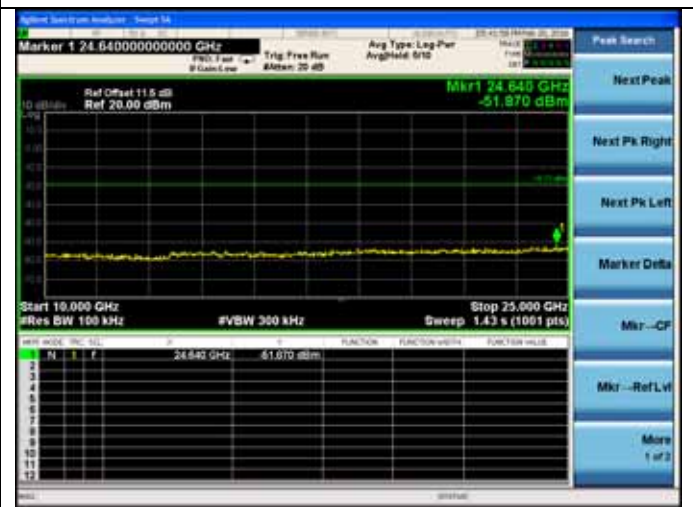
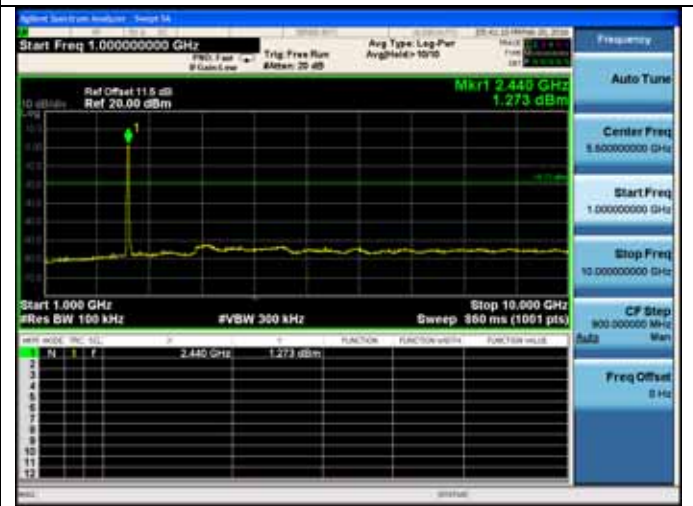
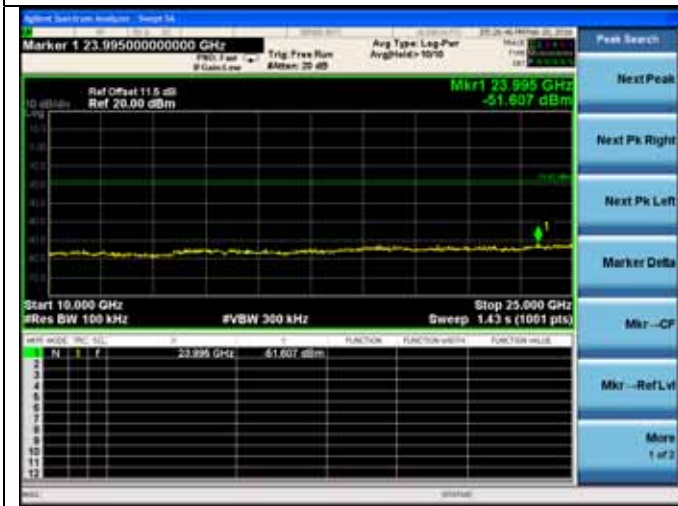
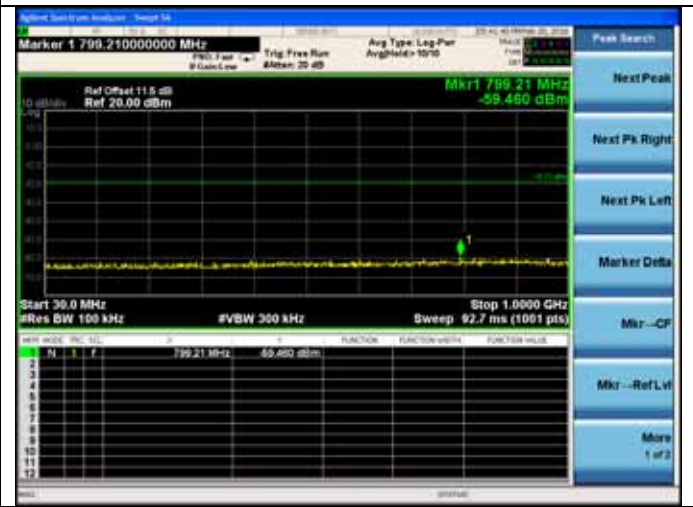
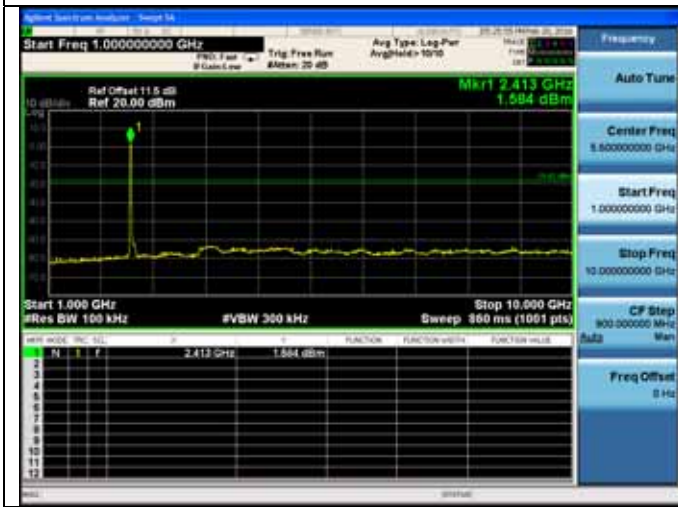

Test CH11: 2462MHz

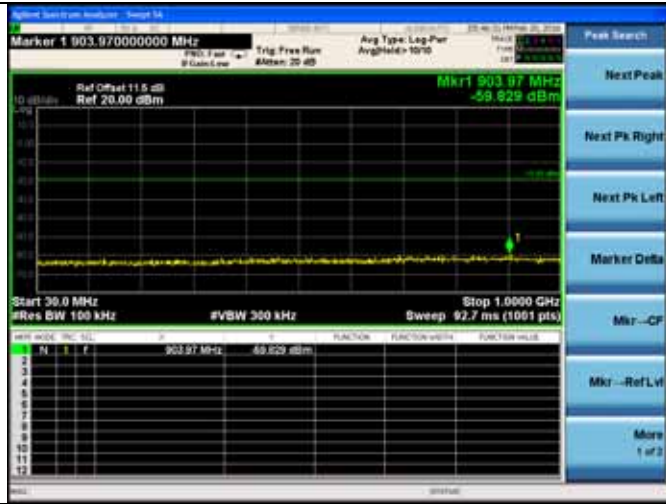

Test Mode: IEEE 802.11n HT20
Test CH1: 2412MHz

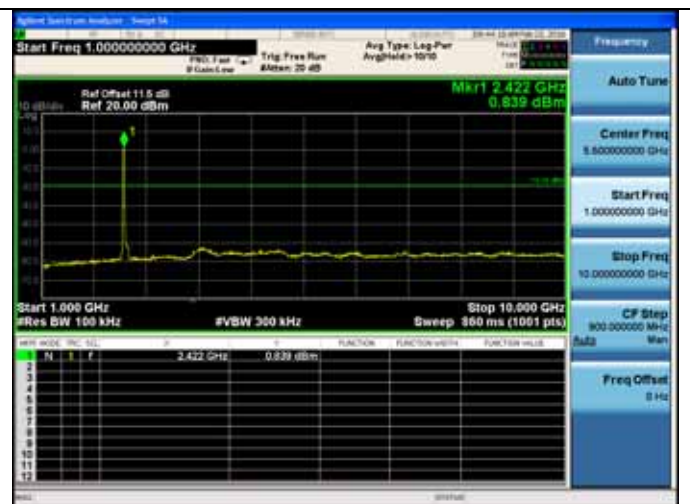
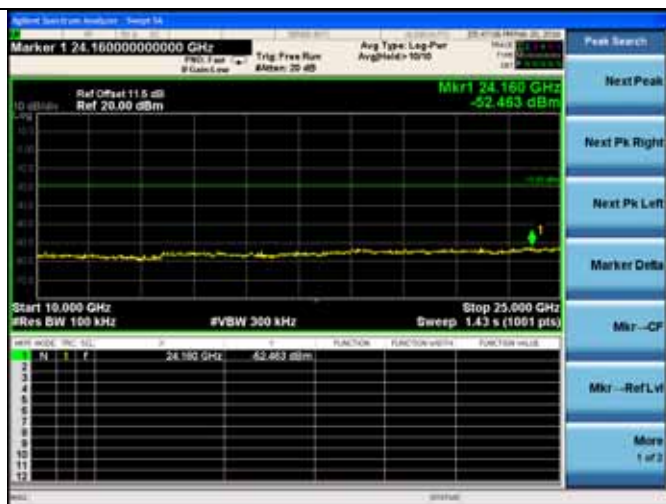

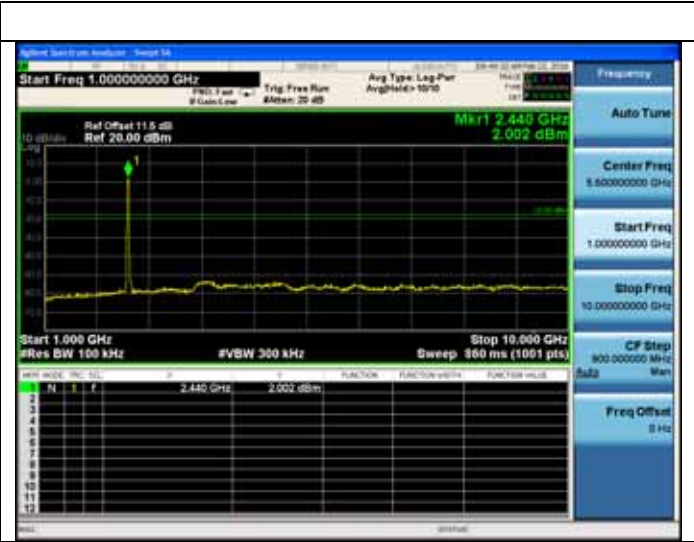
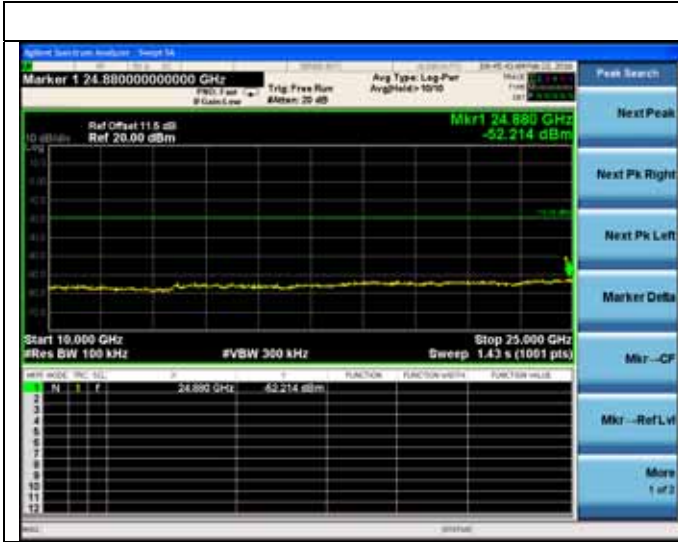

Test CH6: 2437MHz

Test CH11: 2462MHz

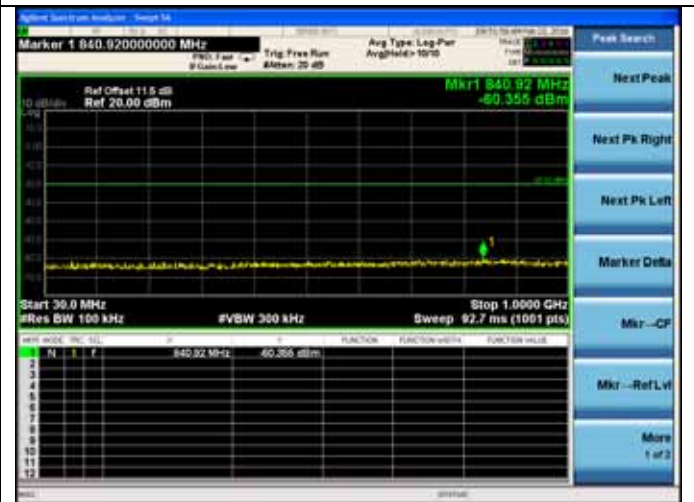
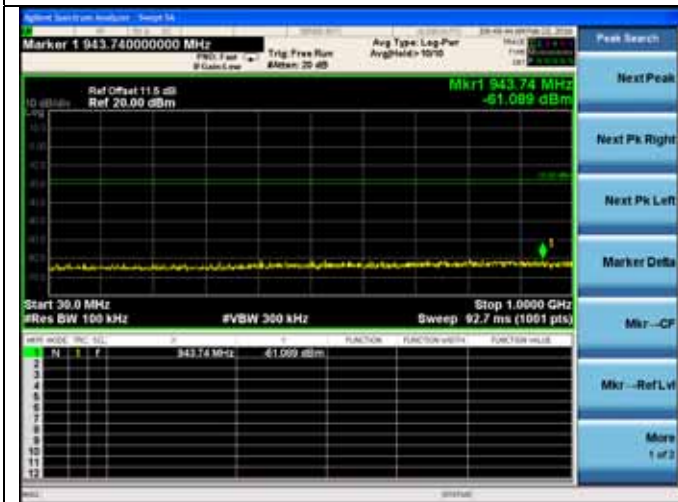

Test Mode: IEEE 802.11n HT40
 Test CH3: 2422MHz

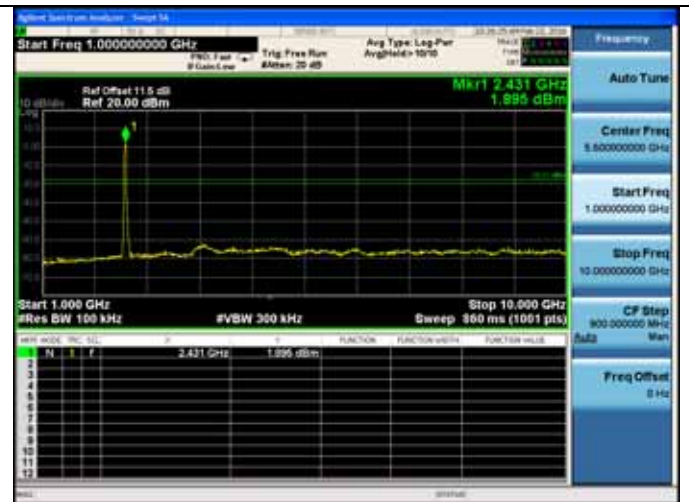
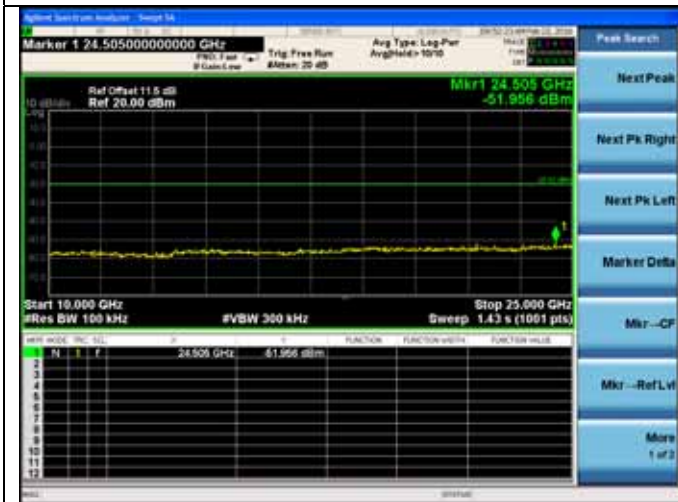
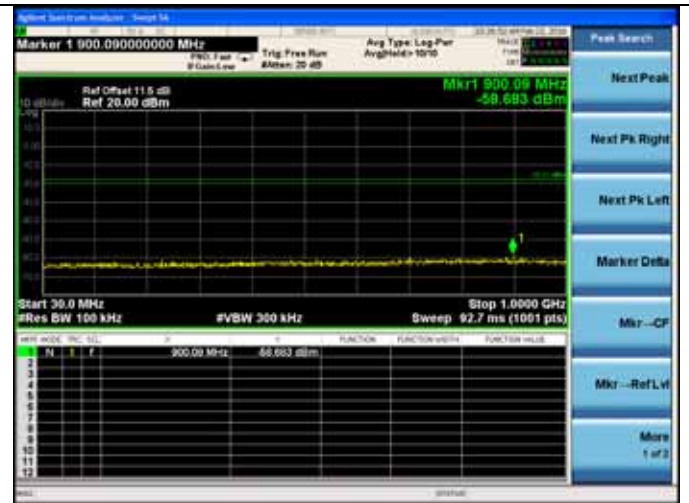
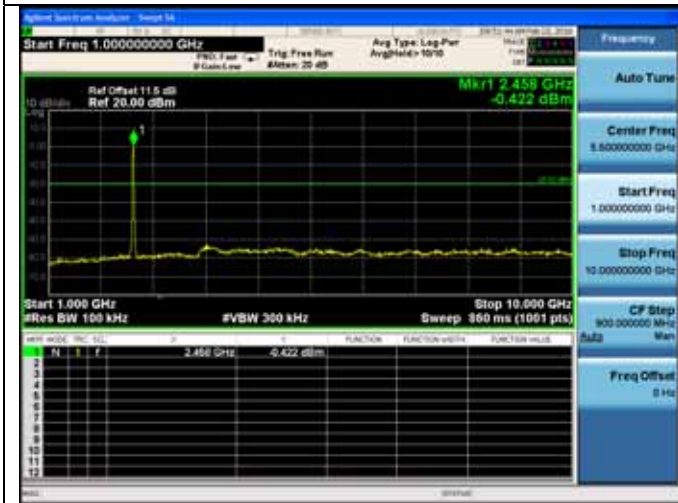



Test CH6: 2437MHz

Test CH9: 2452MHz

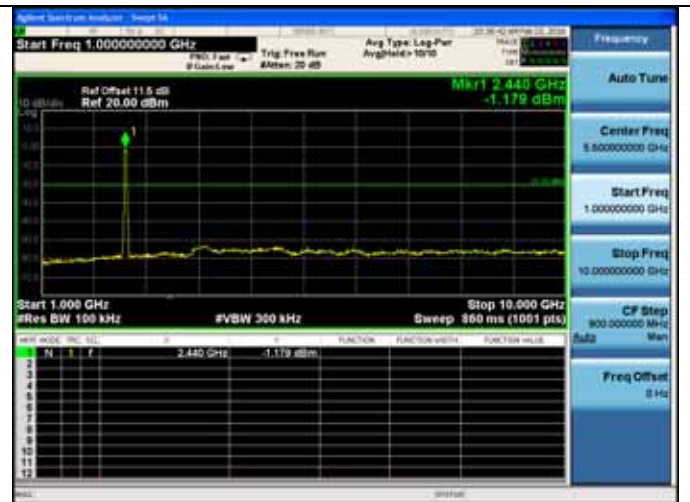
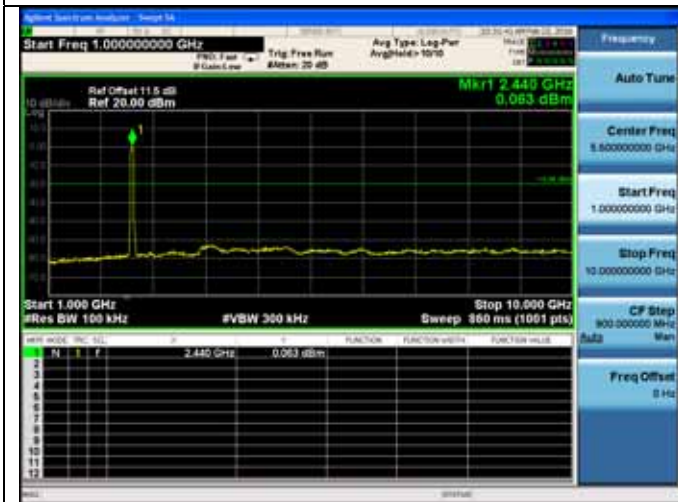
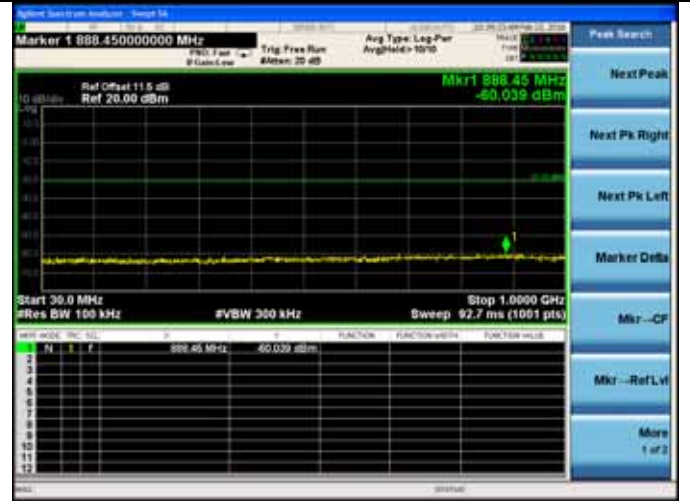
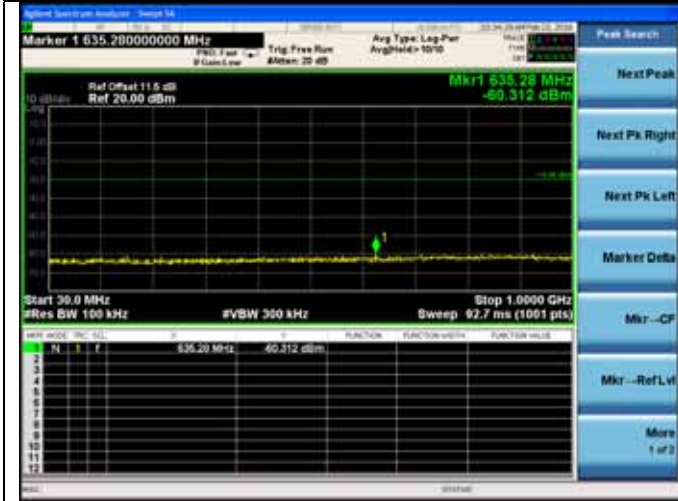



ANT2:

Test Mode: IEEE 802.11b
 Test CH1: 2412MHz

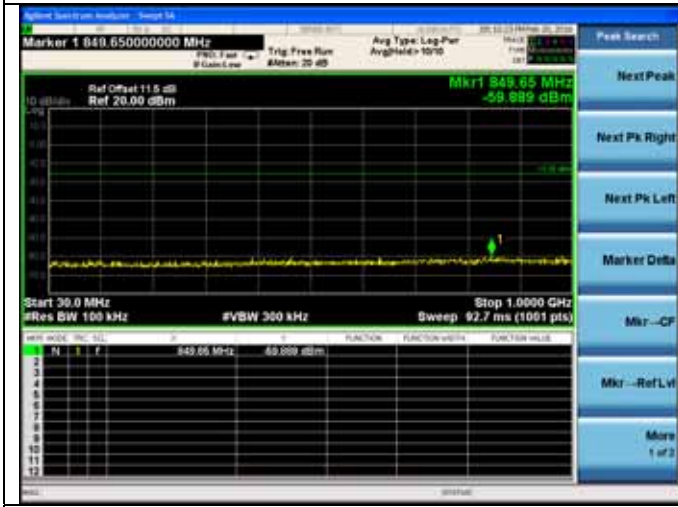

Test CH6: 2437MHz

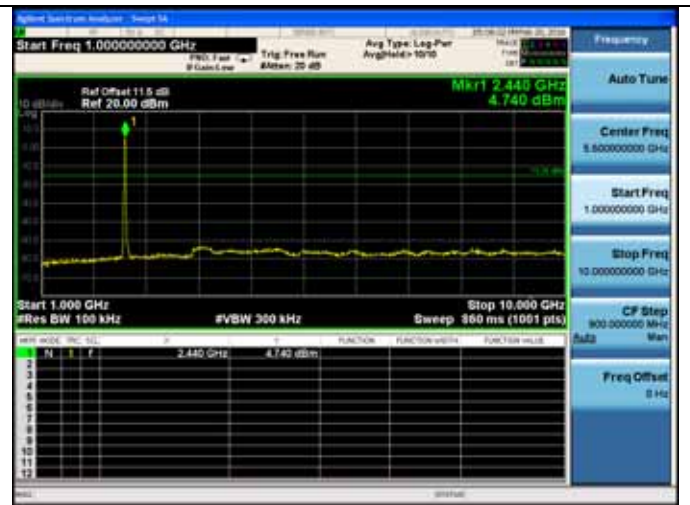
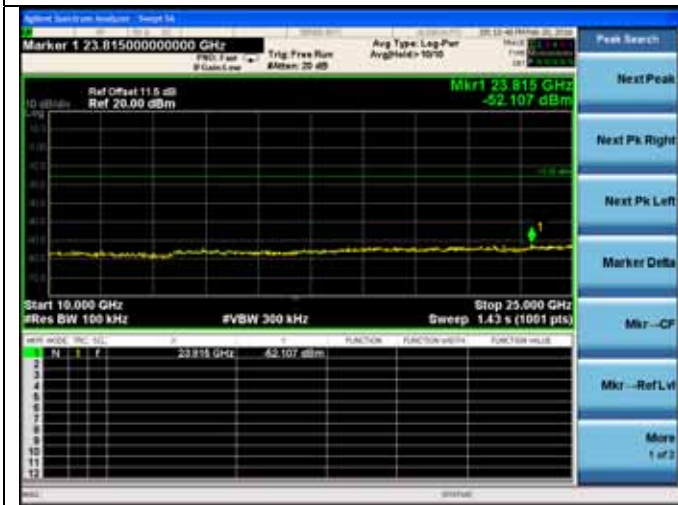

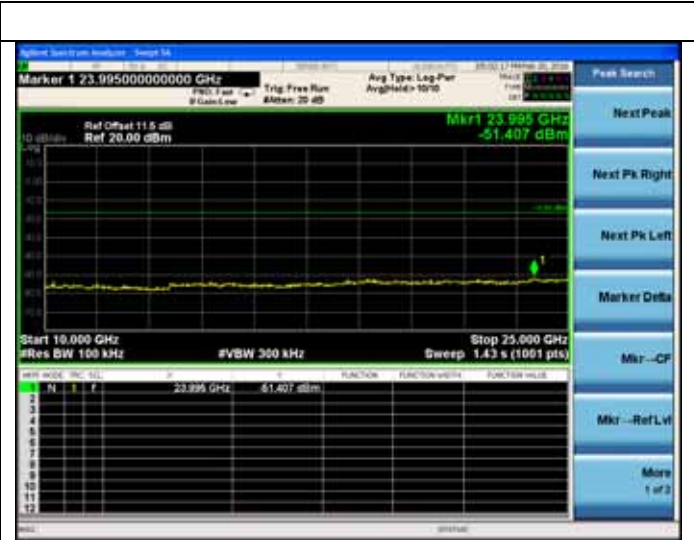
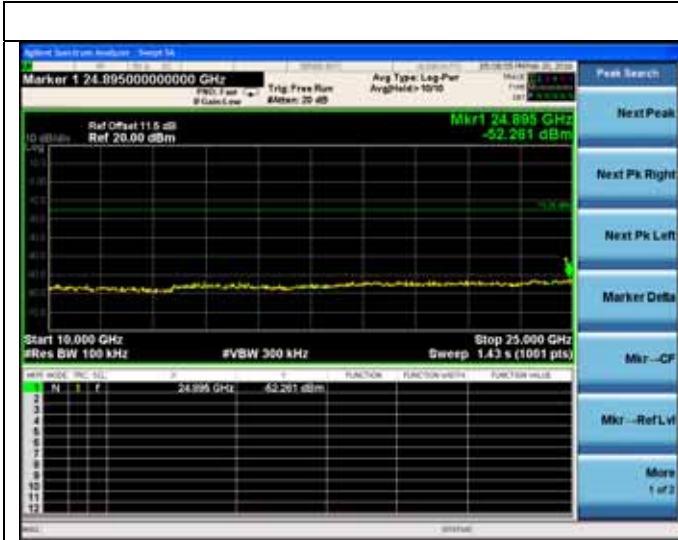

Test CH11: 2462MHz

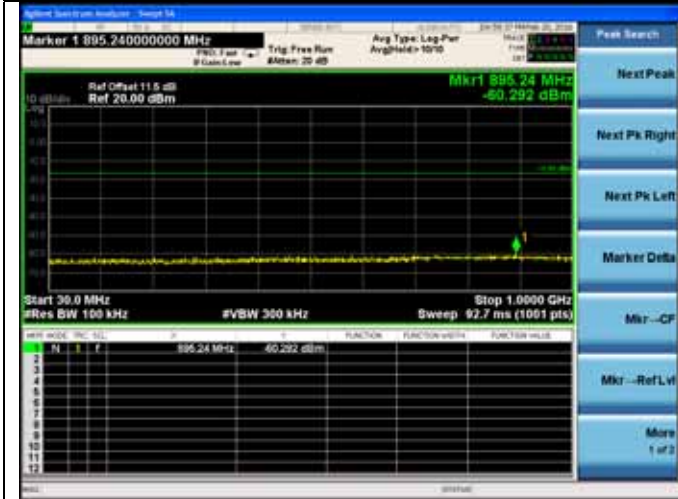

Test Mode: IEEE 802.11g
 Test CH1: 2412MHz

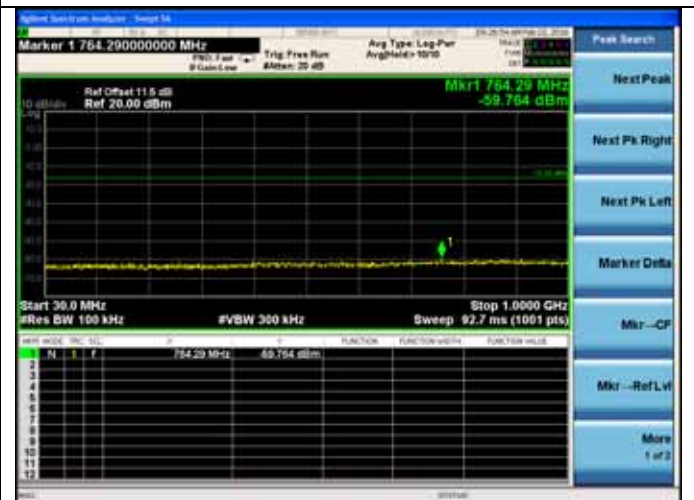
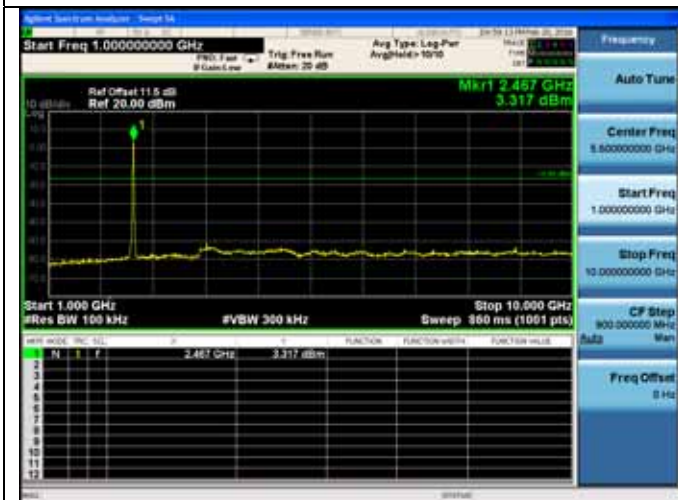

Test CH6: 2437MHz

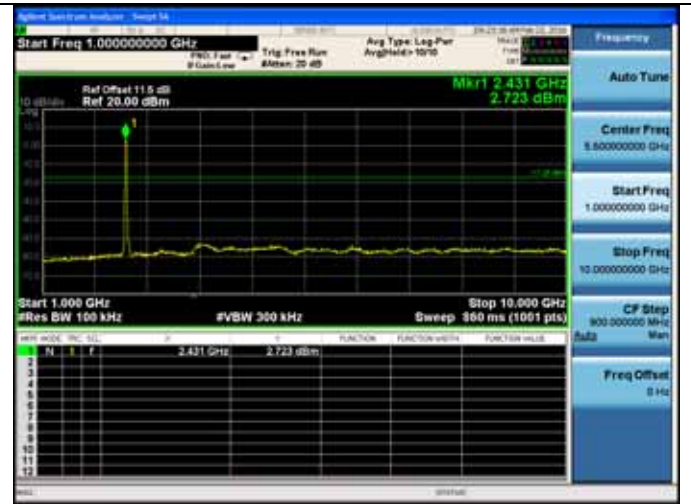
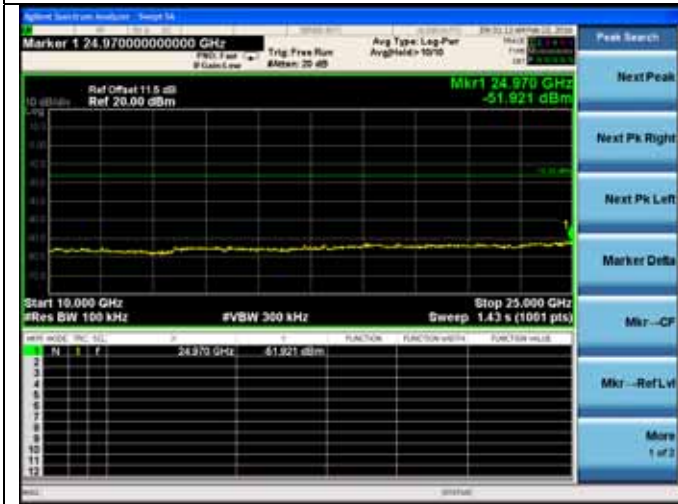
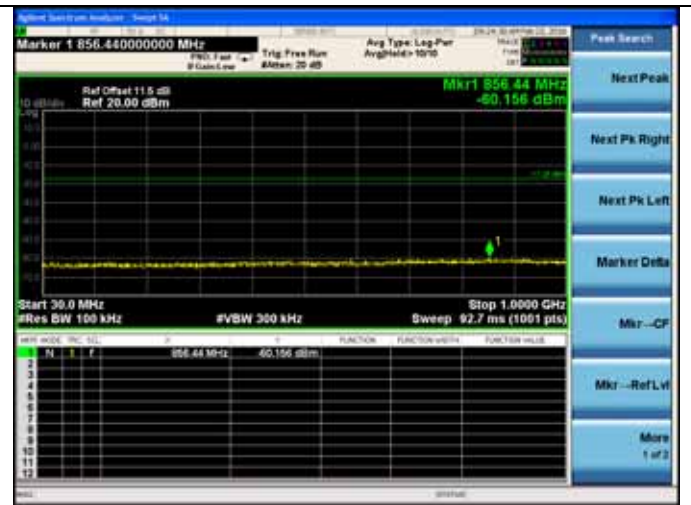
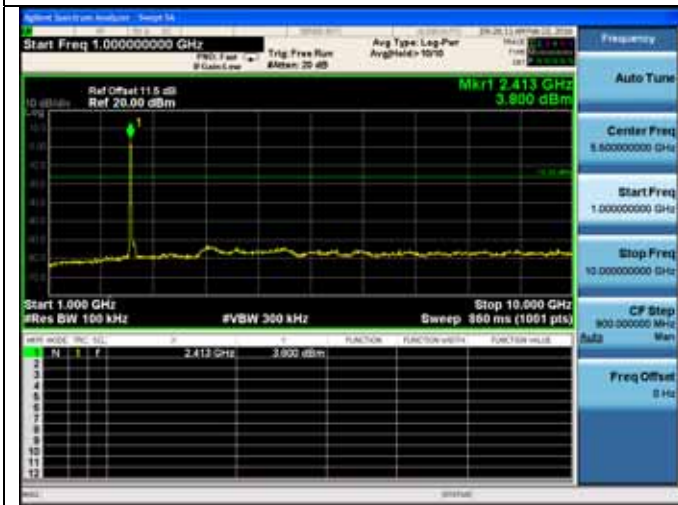

Test CH11: 2462MHz

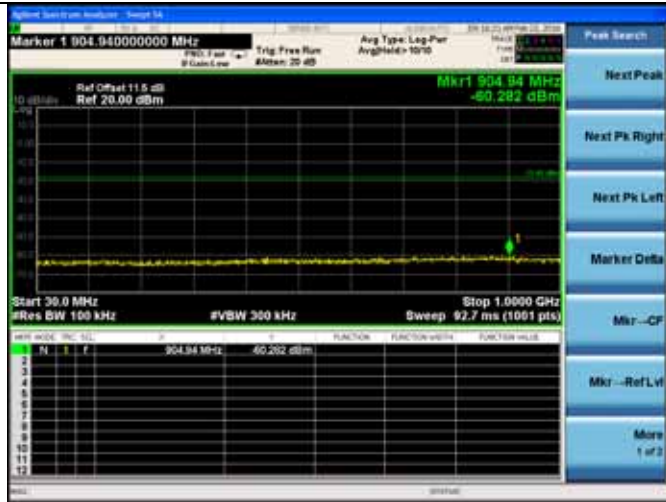

Test Mode: IEEE 802.11n HT20
Test CH1: 2412MHz

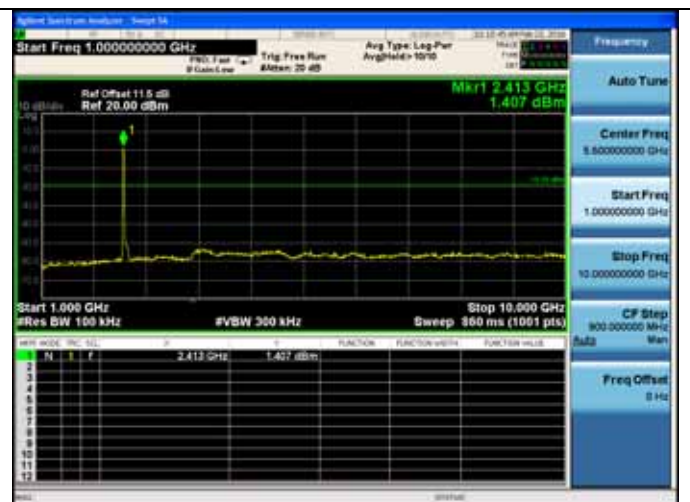
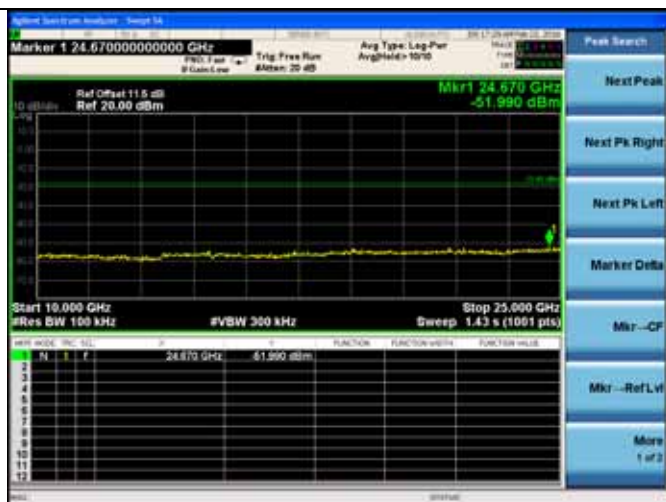
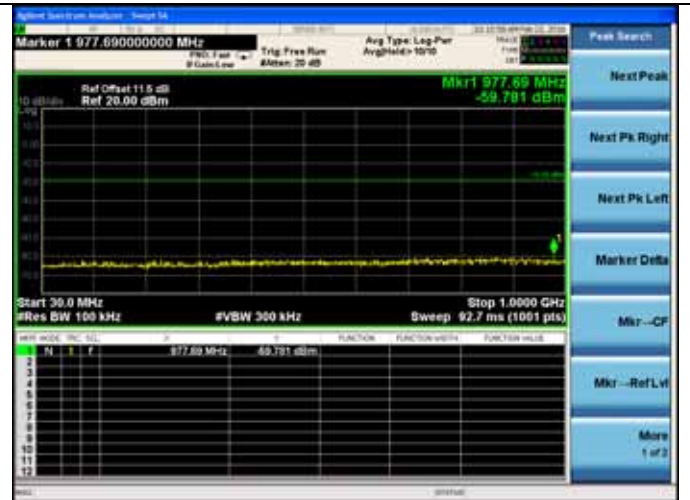
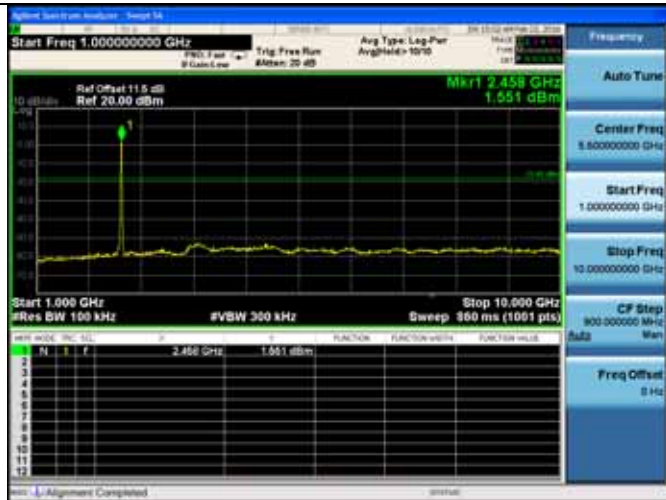

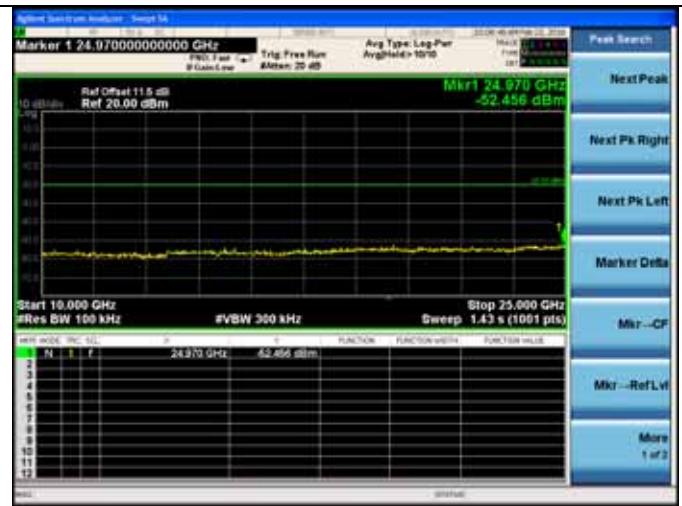
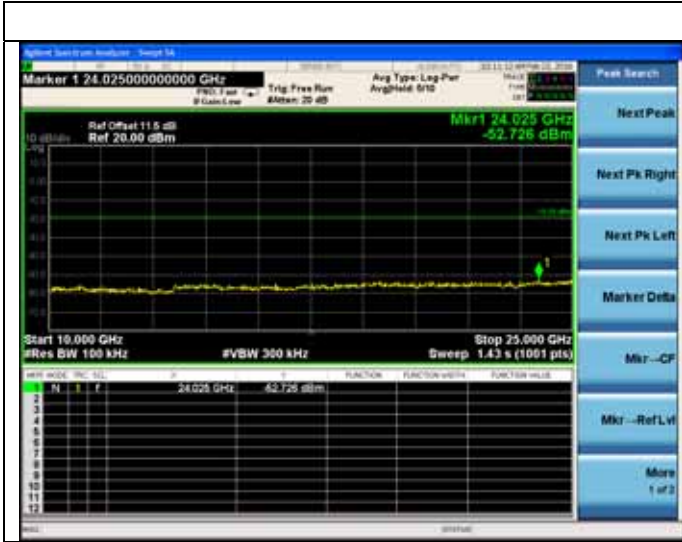

Test CH6: 2437MHz

Test CH11: 2462MHz

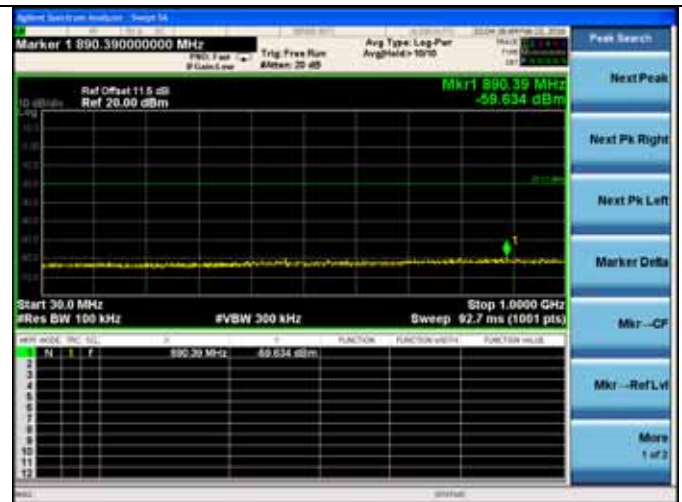
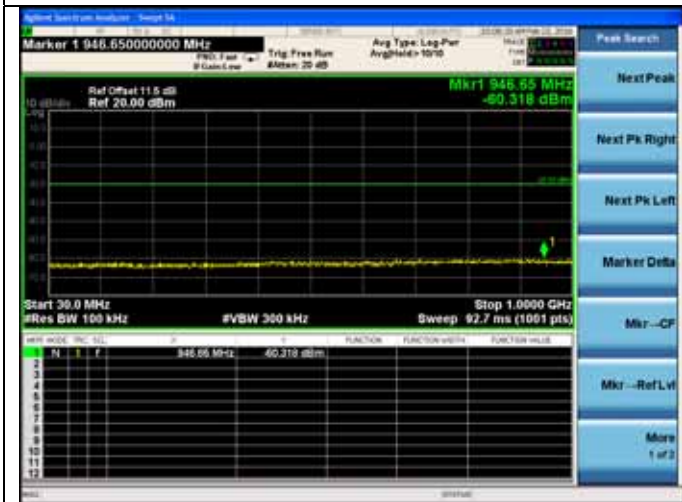

Test Mode: IEEE 802.11n HT40
 Test CH3: 2422MHz

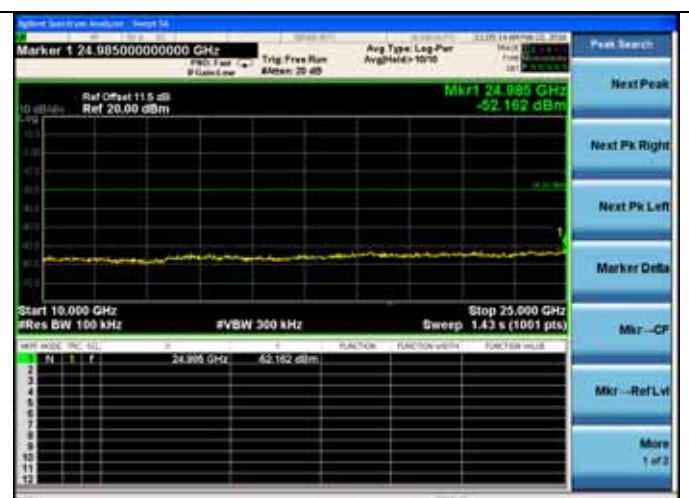
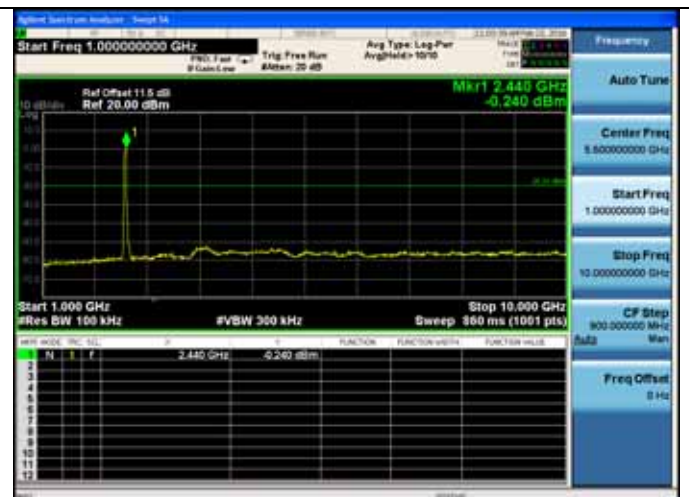
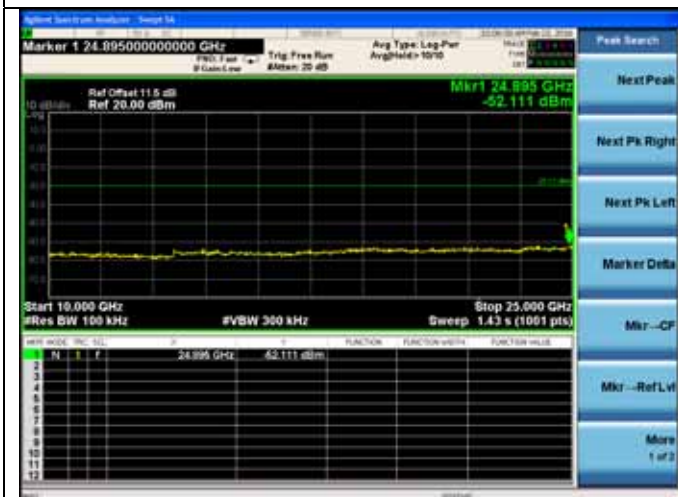
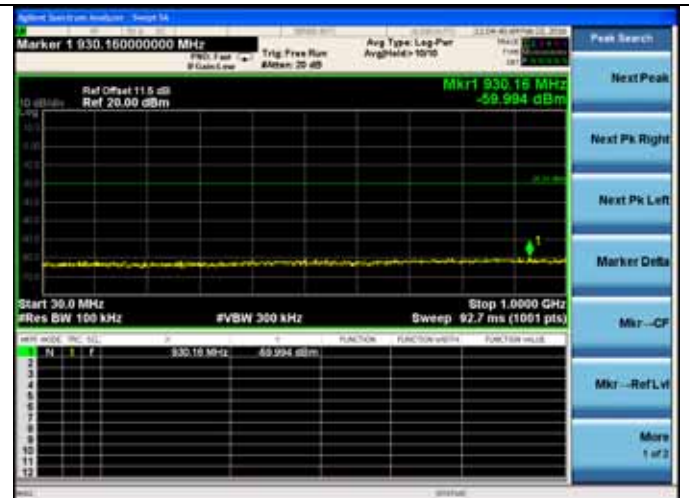
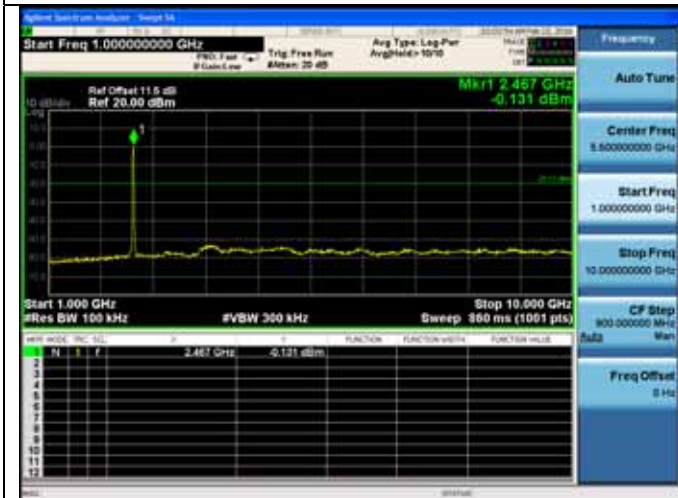



Test CH6: 2437MHz

Test CH9: 2452MHz

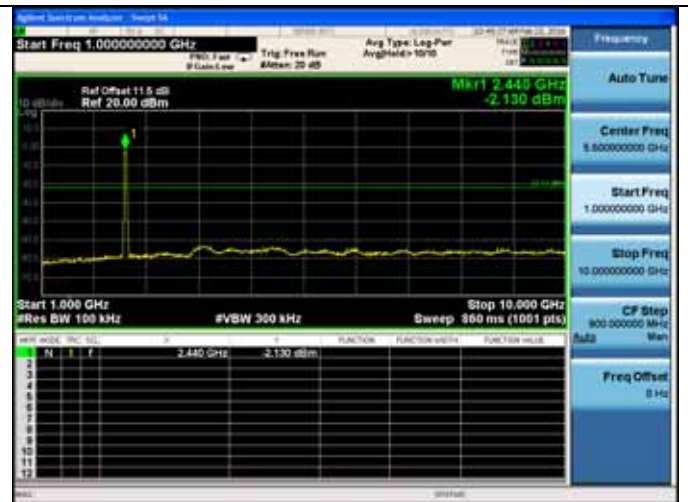
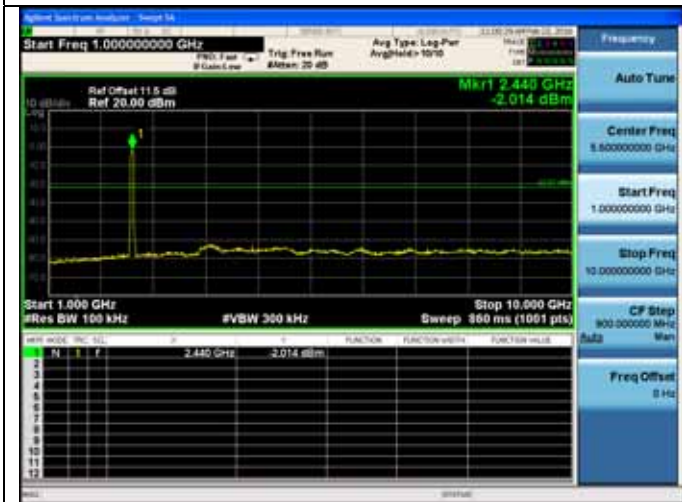
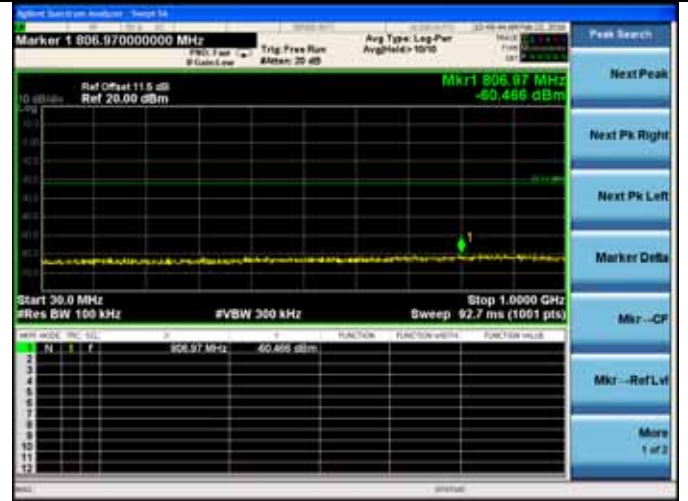
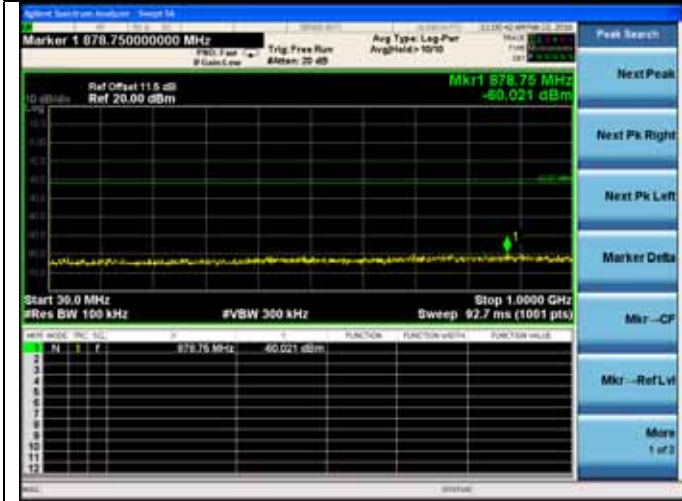



6. BAND EDGE COMPLIANCE TEST

6.1. Test Equipment

Item	Equipment	Manufacturer	Model No.	Serial No.	Last Cal.	Cal. Interval
1.	Spectrum	Agilent	E4446A	US44300459	Apr.28,15	1 Year
2.	Amp	HP	8449B	3008A02495	Apr.28,15	1 Year
3.	Horn Antenna	ETS	3115	9510-4877	Oct.15,15	1 Year
4.	HF Cable	Hubersuhner	Sucoflex104	274094/4	Apr.28,15	1 Year

6.2. Limit

All the lower and upper band-edges emissions appearing within 2310MHz to 2390MHz and 2483.5MHz to 2500MHz restricted frequency bands shall not exceed the limits shown in 15.209, all the other emissions outside operation frequency band 2400MHz to 2483.5MHz shall be at least 20dB below the fundamental emissions, or comply with 15.209 limits.

6.3. Test Produce

1. The EUT is placed on a turntable, which is 1.5m above the ground plane and worked at highest radiated power.
2. The turntable was rotated for 360 degrees to determine the position of maximum emission level.
3. EUT is set 3m away from the receiving antenna, which is varied from 1m to 4m to find out the highest emission.
4. Set the spectrum analyzer in the following setting in order to capture the lower and upper band-edges of the emission:
 - (a) PEAK: RBW=1MHz; VBW=3MHz; Sweep=AUTO
 - (b) AVERAGE: RBW=1MHz; VBW=10Hz; Sweep=AUTO

6.4. Test Results

Pass (The testing data was attached in the next pages.)

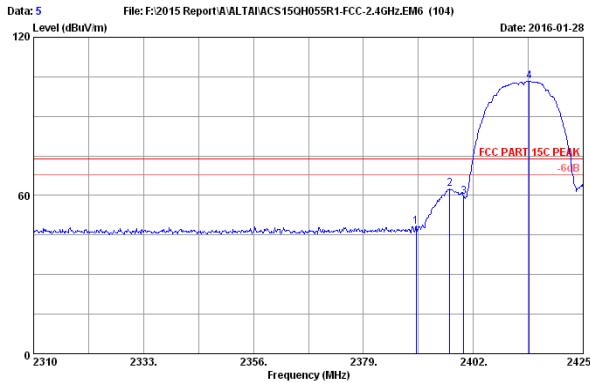

Site no. : 3m Chamber Data no. : 5
 Dis. / Ant. : 3m 2015 MCTD1209 3006 Ant. pol. : HORIZONTAL
 Limit : FCC PART 15C PEAK
 Env. / Ins. : 23°C/54%
 Engineer : Leo-Li
 EUT : Altai A8in (ac) Super WiFi Base Station
 Power rating : DC 56V From POE Input AC 120V/60Hz
 Test Mode : IEEE802.11b 2412Hz Tx
 WA8011NAC-H

No.	Freq. (MHz)	Ant. Factor (dB/m)	Cable Loss (dB)	AMP factor (dB)	Reading (dBuV)	Emission Level (dBuV/m)	Limits (dBuV/m)	Margin (dB)	Remark
1	2390.000	27.98	7.28	36.62	49.64	48.28	74.00	25.72	Peak
2	2397.055	27.99	7.32	36.62	63.03	62.32	74.00	11.48	Peak
3	2400.000	28.00	7.32	36.62	60.77	59.47	74.00	14.53	Peak
4	2413.730	28.03	7.35	36.61	104.63	103.40	74.00	-29.40	Peak

Remarks: 1. Emission Level= Antenna Factor + Cable Loss + Reading - Amp Factor
 2. The emission levels that are 20dB below the official limit are not reported.

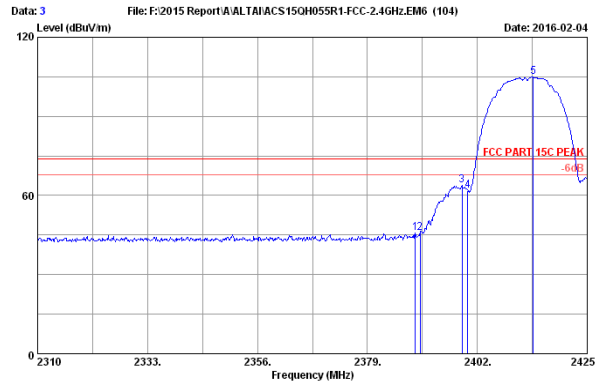

Site no. : 3m Chamber Data no. : 3
 Dis. / Ant. : 3m 2015 MCTD1209 3006 Ant. pol. : VERTICAL
 Limit : FCC PART 15C PEAK
 Env. / Ins. : 23°C/54%
 Engineer : Leo-Li
 EUT : Altai A8in (ac) Super WiFi Base Station
 Power rating : DC 56V From POE Input AC 120V/60Hz
 Test Mode : IEEE802.11b 2412Hz Tx
 WA8011NAC-H

No.	Freq. (MHz)	Ant. Factor (dB/m)	Cable Loss (dB)	AMP factor (dB)	Reading (dBuV)	Emission Level (dBuV/m)	Limits (dBuV/m)	Margin (dB)	Remark
1	2389.005	27.98	7.28	36.62	47.05	45.69	74.00	28.31	Peak
2	2390.000	27.98	7.28	36.62	47.15	45.79	74.00	28.21	Peak
3	2398.780	28.00	7.32	36.62	65.08	63.78	74.00	10.22	Peak
4	2400.000	28.00	7.32	36.62	63.05	61.75	74.00	12.25	Peak
5	2413.730	28.03	7.35	36.61	106.16	104.93	74.00	-30.93	Peak

Remarks: 1. Emission Level= Antenna Factor + Cable Loss + Reading - Amp Factor
 2. The emission levels that are 20dB below the official limit are not reported.

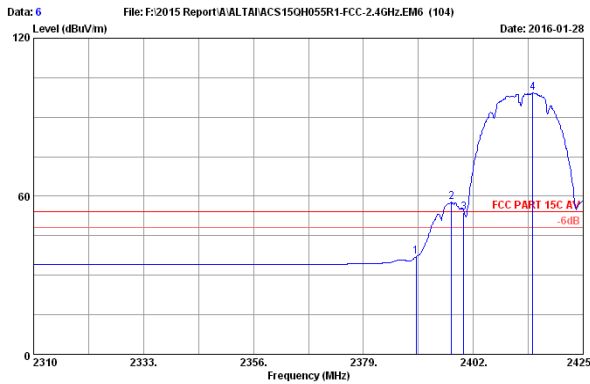

Site no. : 3m Chamber Data no. : 6
 Dis. / Ant. : 3m 2015 MCTD1209 3006 Ant. pol. : HORIZONTAL
 Limit : FCC PART 15C AV
 Env. / Ins. : 23°C/54%
 Engineer : Leo-Li
 EUT : Altai A8in (ac) Super WiFi Base Station
 Power rating : DC 56V From POE Input AC 120V/60Hz
 Test Mode : IEEE802.11b 2412Hz Tx
 WA8011NAC-H

No.	Freq. (MHz)	Ant. Factor (dB/m)	Cable Loss (dB)	AMP factor (dB)	Reading (dBuV)	Emission Level (dBuV/m)	Limits (dBuV/m)	Margin (dB)	Remark
1	2390.000	27.98	7.28	36.62	38.37	37.01	54.00	16.99	Average
2	2397.400	27.99	7.32	36.62	59.16	57.85	54.00	-3.85	Average
3	2400.000	28.00	7.32	36.62	55.20	53.90	54.00	0.10	Average
4	2414.420	28.03	7.35	36.61	100.47	99.24	54.00	-45.24	Average

Remarks: 1. Emission Level= Antenna Factor + Cable Loss + Reading - Amp Factor
 2. The emission levels that are 20dB below the official limit are not reported.

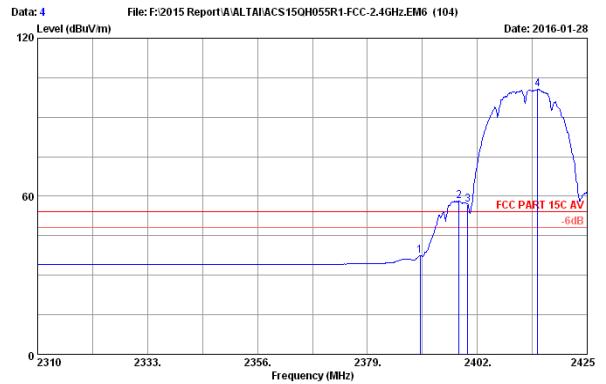

Site no. : 3m Chamber Data no. : 4
 Dis. / Ant. : 3m 2015 MCTD1209 3006 Ant. pol. : VERTICAL
 Limit : FCC PART 15C AV
 Env. / Ins. : 23°C/54%
 Engineer : Leo-Li
 EUT : Altai A8in (ac) Super WiFi Base Station
 Power rating : DC 56V From POE Input AC 120V/60Hz
 Test Mode : IEEE802.11b 2412Hz Tx
 WA8011NAC-H

No.	Freq. (MHz)	Ant. Factor (dB/m)	Cable Loss (dB)	AMP factor (dB)	Reading (dBuV)	Emission Level (dBuV/m)	Limits (dBuV/m)	Margin (dB)	Remark
1	2390.000	27.98	7.28	36.62	38.76	37.40	54.00	16.60	Average
2	2398.205	28.00	7.32	36.62	59.61	58.31	54.00	-4.31	Average
3	2400.000	28.00	7.32	36.62	58.11	56.81	54.00	-2.81	Average
4	2414.650	28.03	7.35	36.61	101.73	100.50	54.00	-46.50	Average

Remarks: 1. Emission Level= Antenna Factor + Cable Loss + Reading - Amp Factor
 2. The emission levels that are 20dB below the official limit are not reported.

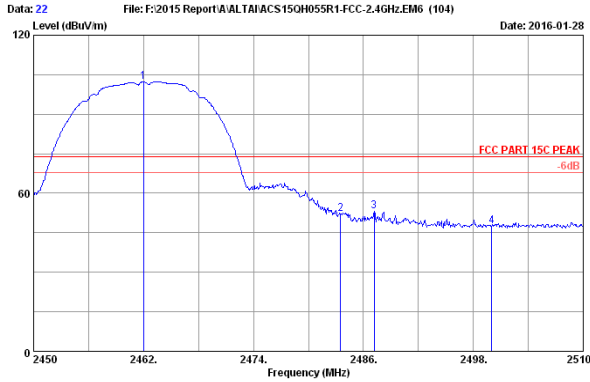

Data: 22 File: F:\2015 Report\A\ALTAIACS150H055R1-FCC-2.4GHz.EM6 (104) Date: 2016-01-28

Site no. : 3m Chamber Data no. : 22
 Dis. / Ant. : 3m 2015 MCTD1209 3006 Ant. pol. : HORIZONTAL
 Limit : FCC PART 15C PEAK
 Env. / Ins. : 23°C/54%
 Engineer : Leo-Li
 EUT : Aitai A8in (ac) Super WiFi Base Station
 Power rating : DC 56V From POE Input AC 120V/60Hz
 Test Mode : IFEES02.11b 2462Hz Tx
 WA8011NAC-H

No.	Freq. (MHz)	Ant. Factor (dB/m)	Cable Loss (dB)	AMP factor (dB)	Reading (dBuV)	Emission Level (dBuV/m)	Limits (dBuV/m)	Margin (dB)	Remark
1	2462.000	28.12	7.43	36.60	103.49	102.44	74.00	-28.44	Peak
2	2483.500	28.17	7.51	36.59	53.11	52.20	74.00	21.80	Peak
3	2487.200	28.17	7.51	36.59	54.05	53.14	74.00	20.86	Peak
4	2500.000	28.20	7.51	36.58	48.39	47.52	74.00	26.48	Peak

Remarks: 1. Emission Level= Antenna Factor + Cable Loss + Reading - Amp Factor
 2. The emission levels that are 20dB below the official limit are not reported.

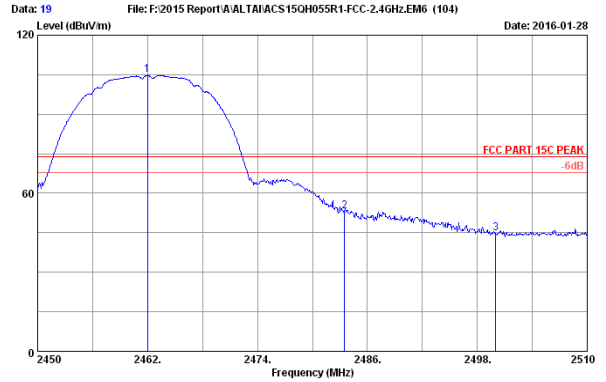

Data: 19 File: F:\2015 Report\A\ALTAIACS150H055R1-FCC-2.4GHz.EM6 (104) Date: 2016-01-28

Site no. : 3m Chamber Data no. : 19
 Dis. / Ant. : 3m 2015 MCTD1209 3006 Ant. pol. : VERTICAL
 Limit : FCC PART 15C PEAK
 Env. / Ins. : 23°C/54%
 Engineer : Leo-Li
 EUT : Aitai A8in (ac) Super WiFi Base Station
 Power rating : DC 56V From POE Input AC 120V/60Hz
 Test Mode : IFEES02.11b 2462Hz Tx
 WA8011NAC-H

No.	Freq. (MHz)	Ant. Factor (dB/m)	Cable Loss (dB)	AMP factor (dB)	Reading (dBuV)	Emission Level (dBuV/m)	Limits (dBuV/m)	Margin (dB)	Remark
1	2462.000	28.12	7.43	36.60	105.89	104.84	74.00	-30.84	Peak
2	2483.500	28.17	7.51	36.59	54.20	53.29	74.00	20.71	Peak
3	2500.000	28.20	7.51	36.58	45.71	44.84	74.00	29.16	Peak

Remarks: 1. Emission Level= Antenna Factor + Cable Loss + Reading - Amp Factor
 2. The emission levels that are 20dB below the official limit are not reported.

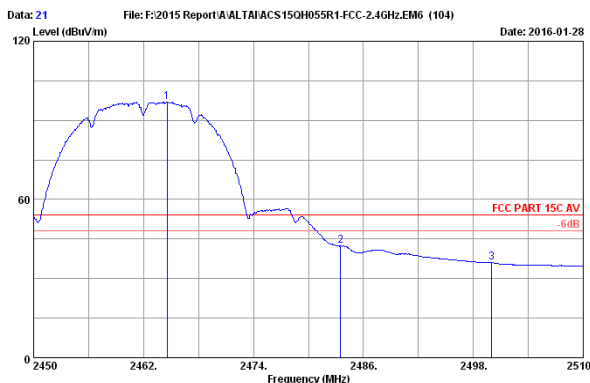

Data: 21 File: F:\2015 Report\A\ALTAIACS150H055R1-FCC-2.4GHz.EM6 (104) Date: 2016-01-28

Site no. : 3m Chamber Data no. : 21
 Dis. / Ant. : 3m 2015 MCTD1209 3006 Ant. pol. : HORIZONTAL
 Limit : FCC PART 15C AV
 Env. / Ins. : 23°C/54%
 Engineer : Leo-Li
 EUT : Aitai A8in (ac) Super WiFi Base Station
 Power rating : DC 56V From POE Input AC 120V/60Hz
 Test Mode : IFEES02.11b 2462Hz Tx
 WA8011NAC-H

No.	Freq. (MHz)	Ant. Factor (dB/m)	Cable Loss (dB)	AMP factor (dB)	Reading (dBuV)	Emission Level (dBuV/m)	Limits (dBuV/m)	Margin (dB)	Remark
1	2464.580	28.13	7.43	36.59	98.06	97.03	54.00	-43.03	Average
2	2483.500	28.17	7.51	36.59	43.27	42.36	54.00	11.64	Average
3	2500.000	28.20	7.51	36.58	36.96	36.09	54.00	17.91	Average

Remarks: 1. Emission Level= Antenna Factor + Cable Loss + Reading - Amp Factor
 2. The emission levels that are 20dB below the official limit are not reported.

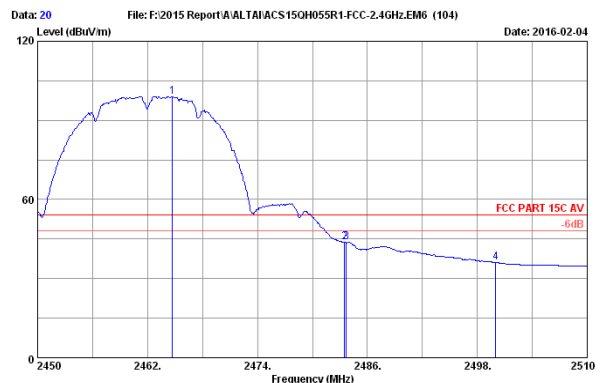

Data: 20 File: F:\2015 Report\A\ALTAIACS150H055R1-FCC-2.4GHz.EM6 (104) Date: 2016-02-04

Site no. : 3m Chamber Data no. : 20
 Dis. / Ant. : 3m 2015 MCTD1209 3006 Ant. pol. : VERTICAL
 Limit : FCC PART 15C AV
 Env. / Ins. : 23°C/54%
 Engineer : Leo-Li
 EUT : Aitai A8in (ac) Super WiFi Base Station
 Power rating : DC 56V From POE Input AC 120V/60Hz
 Test Mode : IFEES02.11b 2462Hz Tx
 WA8011NAC-H

No.	Freq. (MHz)	Ant. Factor (dB/m)	Cable Loss (dB)	AMP factor (dB)	Reading (dBuV)	Emission Level (dBuV/m)	Limits (dBuV/m)	Margin (dB)	Remark
1	2464.700	28.13	7.43	36.59	100.10	99.07	54.00	-45.07	Average
2	2483.500	28.17	7.51	36.59	44.65	43.74	54.00	10.26	Average
3	2483.720	28.17	7.51	36.59	44.79	43.88	54.00	10.12	Average
4	2500.000	28.20	7.51	36.58	37.06	36.19	54.00	17.81	Average

Remarks: 1. Emission Level= Antenna Factor + Cable Loss + Reading - Amp Factor
 2. The emission levels that are 20dB below the official limit are not reported.

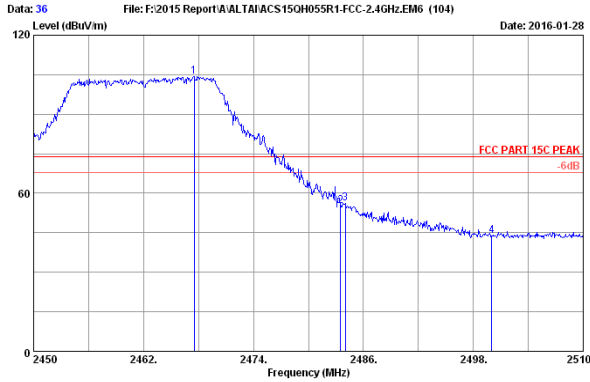

Site no. : 3m Chamber Data no. : 36
 Dis. / Ant. : 3m 2015 MCTD1209 3006 Ant. pol. : HORIZONTAL
 Limit : FCC PART 15C PEAK
 Env. / Ins. : 23°C/54%
 Engineer : Leo-Li
 EUT : Altai 8Bin (ac) Super WiFi Base Station
 Power rating : DC 56V From POE Input AC 120V/60Hz
 Test Mode : IEEE802.11g 2462Hz Tx
 WA8011NAC-H

No.	Freq. (MHz)	Ant. Factor (dB/m)	Cable Loss (dB)	AMP factor (dB)	Reading (dBuV)	Emission Level (dBuV/m)	Limits (dBuV/m)	Margin (dB)	Remark
1	2467.520	28.14	7.47	36.59	105.36	104.38	74.00	-30.38	Peak
2	2483.500	28.17	7.51	36.59	56.10	55.19	74.00	18.81	Peak
3	2484.020	28.17	7.51	36.59	57.12	56.21	74.00	17.79	Peak
4	2500.000	28.20	7.51	36.58	44.65	43.78	74.00	30.22	Peak

Remarks: 1. Emission Level= Antenna Factor + Cable Loss + Reading - Amp Factor
 2. The emission levels that are 20dB below the official limit are not reported.

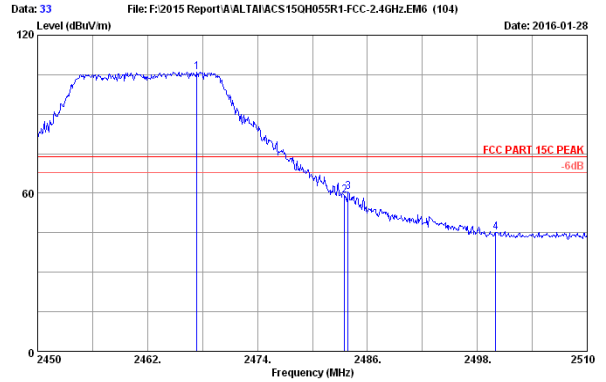

Site no. : 3m Chamber Data no. : 33
 Dis. / Ant. : 3m 2015 MCTD1209 3006 Ant. pol. : VERTICAL
 Limit : FCC PART 15C PEAK
 Env. / Ins. : 23°C/54%
 Engineer : Leo-Li
 EUT : Altai 8Bin (ac) Super WiFi Base Station
 Power rating : DC 56V From POE Input AC 120V/60Hz
 Test Mode : IEEE802.11g 2462Hz Tx
 WA8011NAC-H

No.	Freq. (MHz)	Ant. Factor (dB/m)	Cable Loss (dB)	AMP factor (dB)	Reading (dBuV)	Emission Level (dBuV/m)	Limits (dBuV/m)	Margin (dB)	Remark
1	2467.400	28.13	7.47	36.59	106.95	105.96	74.00	-31.96	Peak
2	2483.500	28.17	7.51	36.59	60.10	59.19	74.00	14.81	Peak
3	2483.900	28.17	7.51	36.59	61.37	60.46	74.00	13.54	Peak
4	2500.000	28.20	7.51	36.58	45.96	45.09	74.00	28.91	Peak

Remarks: 1. Emission Level= Antenna Factor + Cable Loss + Reading - Amp Factor
 2. The emission levels that are 20dB below the official limit are not reported.

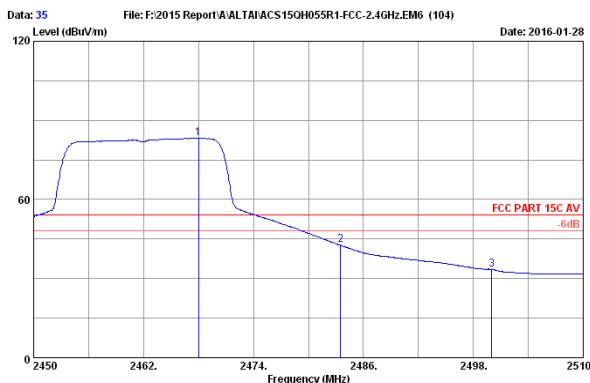

Site no. : 3m Chamber Data no. : 35
 Dis. / Ant. : 3m 2015 MCTD1209 3006 Ant. pol. : HORIZONTAL
 Limit : FCC PART 15C AV
 Env. / Ins. : 23°C/54%
 Engineer : Leo-Li
 EUT : Altai 8Bin (ac) Super WiFi Base Station
 Power rating : DC 56V From POE Input AC 120V/60Hz
 Test Mode : IEEE802.11g 2462Hz Tx
 WA8011NAC-H

No.	Freq. (MHz)	Ant. Factor (dB/m)	Cable Loss (dB)	AMP factor (dB)	Reading (dBuV)	Emission Level (dBuV/m)	Limits (dBuV/m)	Margin (dB)	Remark
1	2468.000	28.14	7.47	36.59	84.16	83.18	54.00	-29.18	Average
2	2483.500	28.17	7.51	36.59	43.54	42.63	54.00	11.37	Average
3	2500.000	28.20	7.51	36.58	34.39	33.52	54.00	20.48	Average

Remarks: 1. Emission Level= Antenna Factor + Cable Loss + Reading - Amp Factor
 2. The emission levels that are 20dB below the official limit are not reported.

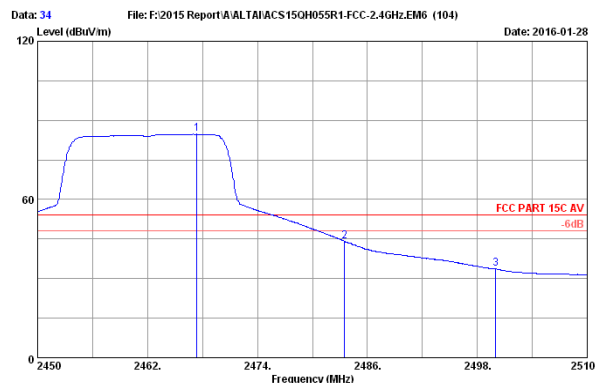

Site no. : 3m Chamber Data no. : 34
 Dis. / Ant. : 3m 2015 MCTD1209 3006 Ant. pol. : VERTICAL
 Limit : FCC PART 15C AV
 Env. / Ins. : 23°C/54%
 Engineer : Leo-Li
 EUT : Altai 8Bin (ac) Super WiFi Base Station
 Power rating : DC 56V From POE Input AC 120V/60Hz
 Test Mode : IEEE802.11g 2462Hz Tx
 WA8011NAC-H

No.	Freq. (MHz)	Ant. Factor (dB/m)	Cable Loss (dB)	AMP factor (dB)	Reading (dBuV)	Emission Level (dBuV/m)	Limits (dBuV/m)	Margin (dB)	Remark
1	2467.400	28.13	7.47	36.59	85.73	84.74	54.00	-30.74	Average
2	2483.500	28.17	7.51	36.59	45.07	44.16	54.00	9.84	Average
3	2500.000	28.20	7.51	36.58	34.54	33.67	54.00	20.33	Average

Remarks: 1. Emission Level= Antenna Factor + Cable Loss + Reading - Amp Factor
 2. The emission levels that are 20dB below the official limit are not reported.

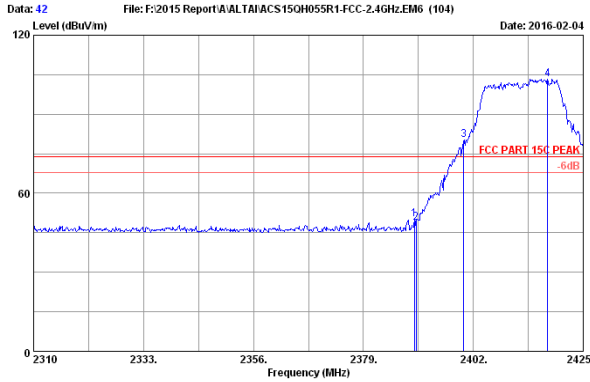

Site no. : 3m Chamber Data no. : 42
 Dis. / Ant. : 3m 2015 MCTD1209 3006 Ant. pol. : HORIZONTAL
 Limit : FCC PART 15C PEAK
 Env. / Ins. : 23°C/54%
 Engineer : Leo-Li
 EUT : Airtel 8Bin (ac) Super WiFi Base Station
 Power rating : DC 56V From POE Input AC 120V/60Hz
 Test Mode : IEEE802.11g 2412Hz Tx
 WA8011NAC-H

No.	Freq. (MHz)	Ant. Factor (dB/m)	Cable Loss (dB)	AMP factor (dB)	Reading (dBuV)	Emission Level (dBuV/m)	Limits (dBuV/m)	Margin (dB)	Remark
1	2389.695	27.98	7.28	36.62	51.62	50.26	74.00	23.74	Peak
2	2390.000	27.98	7.28	36.62	50.10	48.74	74.00	25.26	Peak
3	2400.000	28.00	7.32	36.62	81.50	80.20	74.00	-6.20	Peak
4	2417.525	28.04	7.35	36.61	104.62	103.40	74.00	-29.40	Peak

Remarks: 1. Emission Level= Antenna Factor + Cable Loss + Reading - Amp Factor
 2. The emission levels that are 20dB below the official limit are not reported.

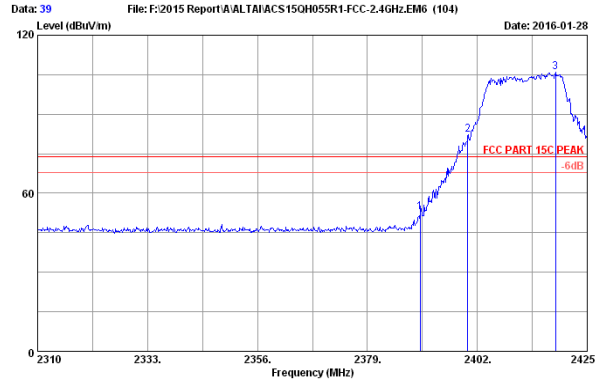

Site no. : 3m Chamber Data no. : 39
 Dis. / Ant. : 3m 2015 MCTD1209 3006 Ant. pol. : VERTICAL
 Limit : FCC PART 15C PEAK
 Env. / Ins. : 23°C/54%
 Engineer : Leo-Li
 EUT : Airtel 8Bin (ac) Super WiFi Base Station
 Power rating : DC 56V From POE Input AC 120V/60Hz
 Test Mode : IEEE802.11g 2412Hz Tx
 WA8011NAC-H

No.	Freq. (MHz)	Ant. Factor (dB/m)	Cable Loss (dB)	AMP factor (dB)	Reading (dBuV)	Emission Level (dBuV/m)	Limits (dBuV/m)	Margin (dB)	Remark
1	2390.000	27.98	7.28	36.62	54.18	52.82	74.00	21.18	Peak
2	2400.000	28.00	7.32	36.62	83.44	82.14	74.00	-8.14	Peak
3	2418.330	28.04	7.35	36.61	107.16	105.94	74.00	-31.94	Peak

Remarks: 1. Emission Level= Antenna Factor + Cable Loss + Reading - Amp Factor
 2. The emission levels that are 20dB below the official limit are not reported.

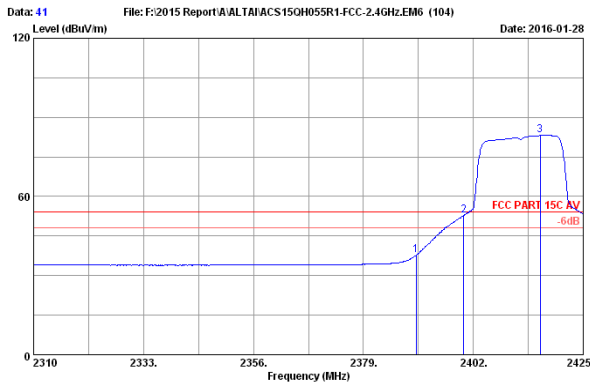

Site no. : 3m Chamber Data no. : 41
 Dis. / Ant. : 3m 2015 MCTD1209 3006 Ant. pol. : HORIZONTAL
 Limit : FCC PART 15C AV
 Env. / Ins. : 23°C/54%
 Engineer : Leo-Li
 EUT : Airtel 8Bin (ac) Super WiFi Base Station
 Power rating : DC 56V From POE Input AC 120V/60Hz
 Test Mode : IEEE802.11g 2412Hz Tx
 WA8011NAC-H

No.	Freq. (MHz)	Ant. Factor (dB/m)	Cable Loss (dB)	AMP factor (dB)	Reading (dBuV)	Emission Level (dBuV/m)	Limits (dBuV/m)	Margin (dB)	Remark
1	2390.000	27.98	7.28	36.62	39.08	37.72	54.00	16.28	Average
2	2400.000	28.00	7.32	36.62	54.23	52.93	54.00	1.07	Average
3	2416.030	28.03	7.35	36.61	84.36	83.13	54.00	-29.13	Average

Remarks: 1. Emission Level= Antenna Factor + Cable Loss + Reading - Amp Factor
 2. The emission levels that are 20dB below the official limit are not reported.

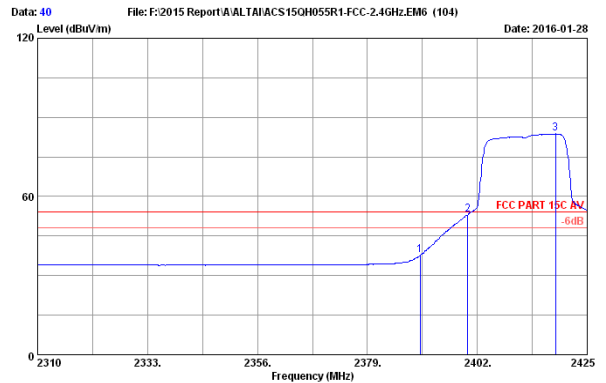

Site no. : 3m Chamber Data no. : 40
 Dis. / Ant. : 3m 2015 MCTD1209 3006 Ant. pol. : VERTICAL
 Limit : FCC PART 15C AV
 Env. / Ins. : 23°C/54%
 Engineer : Leo-Li
 EUT : Airtel 8Bin (ac) Super WiFi Base Station
 Power rating : DC 56V From POE Input AC 120V/60Hz
 Test Mode : IEEE802.11g 2412Hz Tx
 WA8011NAC-H

No.	Freq. (MHz)	Ant. Factor (dB/m)	Cable Loss (dB)	AMP factor (dB)	Reading (dBuV)	Emission Level (dBuV/m)	Limits (dBuV/m)	Margin (dB)	Remark
1	2390.000	27.98	7.28	36.62	39.04	37.68	54.00	16.32	Average
2	2400.000	28.00	7.32	36.62	54.51	53.21	54.00	0.79	Average
3	2418.330	28.04	7.35	36.61	84.98	83.76	54.00	-29.76	Average

Remarks: 1. Emission Level= Antenna Factor + Cable Loss + Reading - Amp Factor
 2. The emission levels that are 20dB below the official limit are not reported.

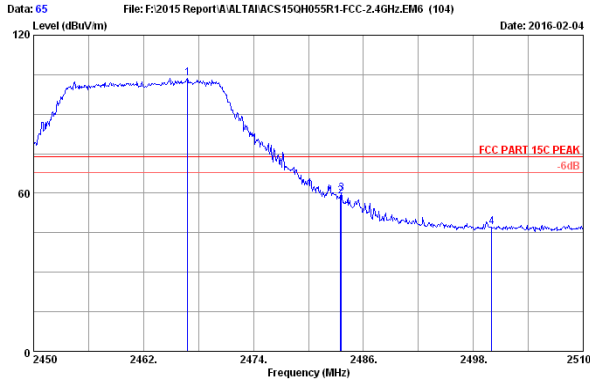

Site no. : 3m Chamber Data no. : 65
 Dis. / Ant. : 3m 2015 MCTD1209 3006 Ant. pol. : HORIZONTAL
 Limit : FCC PART 15C PEAK
 Env. / Ins. : 23°C/54%
 Engineer : Leo-Li
 EUT : Aitai A8in (ac) Super WiFi Base Station
 Power rating : DC 56V From POE Input AC 120V/60Hz
 Test Mode : IFEES02.11nHT20 2462Hz Tx
 WA8011NAC-H

No.	Freq. (MHz)	Ant. Factor (dB/m)	Cable Loss (dB)	AMP factor (dB)	Reading (dBuV)	Emission Level (dBuV/m)	Limits (dBuV/m)	Margin (dB)	Remark
1	2466.800	28.13	7.47	36.59	104.68	103.69	74.00	-29.69	Peak
2	2483.500	28.17	7.51	36.59	59.87	58.96	74.00	15.04	Peak
3	2483.600	28.17	7.51	36.59	60.76	59.85	74.00	14.15	Peak
4	2500.000	28.20	7.51	36.58	47.84	46.97	74.00	27.03	Peak

Remarks: 1. Emission Level= Antenna Factor + Cable Loss + Reading - Amp Factor
 2. The emission levels that are 20dB below the official limit are not reported.

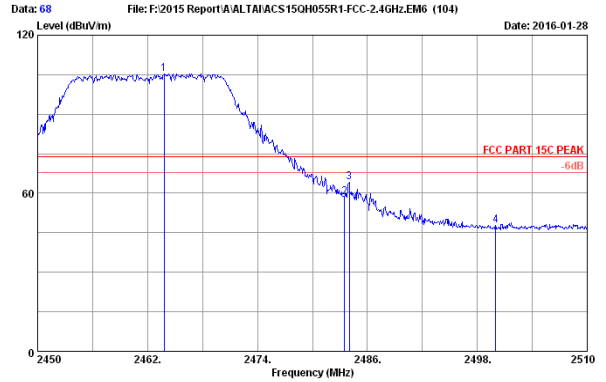

Site no. : 3m Chamber Data no. : 68
 Dis. / Ant. : 3m 2015 MCTD1209 3006 Ant. pol. : VERTICAL
 Limit : FCC PART 15C PEAK
 Env. / Ins. : 23°C/54%
 Engineer : Leo-Li
 EUT : Aitai A8in (ac) Super WiFi Base Station
 Power rating : DC 56V From POE Input AC 120V/60Hz
 Test Mode : IFEES02.11nHT20 2462Hz Tx
 WA8011NAC-H

No.	Freq. (MHz)	Ant. Factor (dB/m)	Cable Loss (dB)	AMP factor (dB)	Reading (dBuV)	Emission Level (dBuV/m)	Limits (dBuV/m)	Margin (dB)	Remark
1	2463.800	28.13	7.43	36.59	106.48	105.45	74.00	-31.45	Peak
2	2483.500	28.17	7.51	36.59	59.32	58.41	74.00	15.59	Peak
3	2484.020	28.17	7.51	36.59	65.24	64.33	74.00	9.67	Peak
4	2500.000	28.20	7.51	36.58	48.56	47.69	74.00	26.31	Peak

Remarks: 1. Emission Level= Antenna Factor + Cable Loss + Reading - Amp Factor
 2. The emission levels that are 20dB below the official limit are not reported.

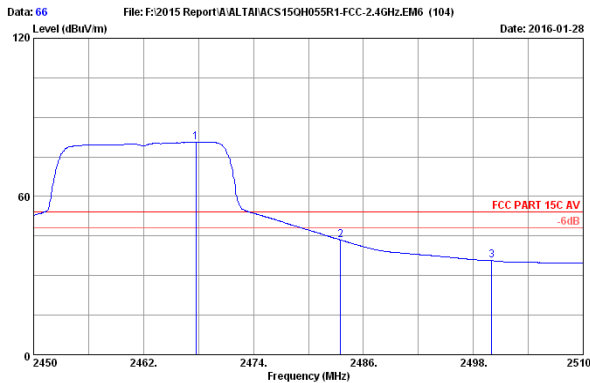

Site no. : 3m Chamber Data no. : 66
 Dis. / Ant. : 3m 2015 MCTD1209 3006 Ant. pol. : HORIZONTAL
 Limit : FCC PART 15C AV
 Env. / Ins. : 23°C/54%
 Engineer : Leo-Li
 EUT : Aitai A8in (ac) Super WiFi Base Station
 Power rating : DC 56V From POE Input AC 120V/60Hz
 Test Mode : IFEES02.11nHT20 2462Hz Tx
 WA8011NAC-H

No.	Freq. (MHz)	Ant. Factor (dB/m)	Cable Loss (dB)	AMP factor (dB)	Reading (dBuV)	Emission Level (dBuV/m)	Limits (dBuV/m)	Margin (dB)	Remark
1	2467.700	28.14	7.47	36.59	81.58	80.60	54.00	-26.60	Average
2	2483.500	28.17	7.51	36.59	44.47	43.56	54.00	10.44	Average
3	2500.000	28.20	7.51	36.58	36.59	35.72	54.00	18.28	Average

Remarks: 1. Emission Level= Antenna Factor + Cable Loss + Reading - Amp Factor
 2. The emission levels that are 20dB below the official limit are not reported.

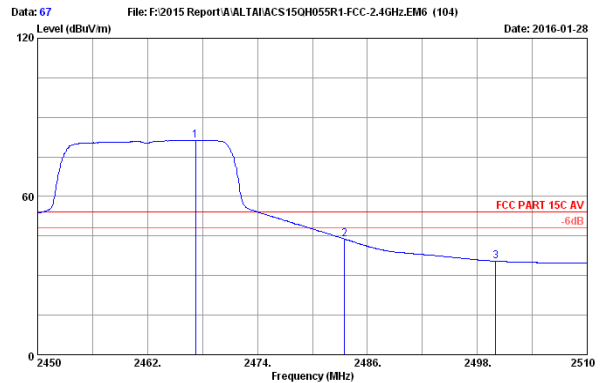

Site no. : 3m Chamber Data no. : 67
 Dis. / Ant. : 3m 2015 MCTD1209 3006 Ant. pol. : VERTICAL
 Limit : FCC PART 15C AV
 Env. / Ins. : 23°C/54%
 Engineer : Leo-Li
 EUT : Aitai A8in (ac) Super WiFi Base Station
 Power rating : DC 56V From POE Input AC 120V/60Hz
 Test Mode : IFEES02.11nHT20 2462Hz Tx
 WA8011NAC-H

No.	Freq. (MHz)	Ant. Factor (dB/m)	Cable Loss (dB)	AMP factor (dB)	Reading (dBuV)	Emission Level (dBuV/m)	Limits (dBuV/m)	Margin (dB)	Remark
1	2467.220	28.13	7.47	36.59	82.33	81.34	54.00	-27.34	Average
2	2483.500	28.17	7.51	36.59	44.72	43.81	54.00	10.19	Average
3	2500.000	28.20	7.51	36.58	36.42	35.55	54.00	18.45	Average

Remarks: 1. Emission Level= Antenna Factor + Cable Loss + Reading - Amp Factor
 2. The emission levels that are 20dB below the official limit are not reported.

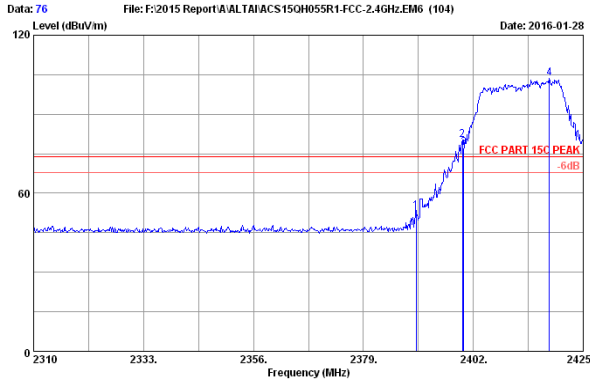

Data: 76 File: F:\2015 Report\A\ALTAIACS150H055R1-FCC-2.4GHz.EM6 (104) Date: 2016-01-28

Site no. : 3m Chamber Data no. : 76
 Dis. / Ant. : 3m 2015 MCTD1209 3006 Ant. pol. : HORIZONTAL
 Limit : FCC PART 15C PEAK
 Env. / Ins. : 23°C/54%
 Engineer : Leo-Li
 EUT : Aitai A8in (ac) Super WiFi Base Station
 Power rating : DC 56V From POE Input AC 120V/60Hz
 Test Mode : IEEE802.11nHT20 2412Hz Tx
 WA8011NAC-H

No.	Freq. (MHz)	Ant. Factor (dB/m)	Cable Loss (dB)	AMP factor (dB)	Reading (dBuV)	Emission Level (dBuV/m)	Limits (dBuV/m)	Margin (dB)	Remark
1	2390.000	27.98	7.28	36.62	54.54	53.18	74.00	20.82	Peak
2	2399.700	28.00	7.32	36.62	81.62	80.32	74.00	-6.32	Peak
3	2400.000	28.00	7.32	36.62	78.36	77.06	74.00	-3.06	Peak
4	2417.870	28.04	7.35	36.61	104.78	103.56	74.00	-29.56	Peak

Remarks: 1. Emission Level= Antenna Factor + Cable Loss + Reading - Amp Factor
 2. The emission levels that are 20dB below the official limit are not reported.

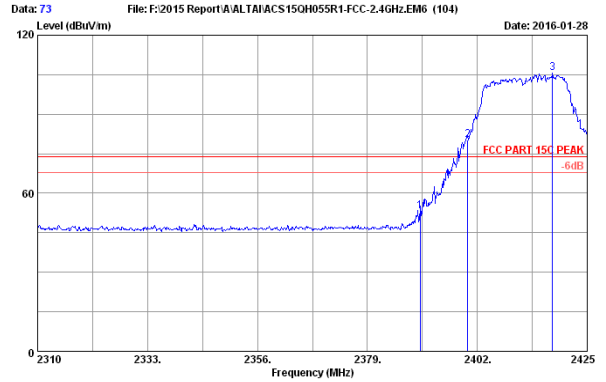

Data: 73 File: F:\2015 Report\A\ALTAIACS150H055R1-FCC-2.4GHz.EM6 (104) Date: 2016-01-28

Site no. : 3m Chamber Data no. : 73
 Dis. / Ant. : 3m 2015 MCTD1209 3006 Ant. pol. : VERTICAL
 Limit : FCC PART 15C PEAK
 Env. / Ins. : 23°C/54%
 Engineer : Leo-Li
 EUT : Aitai A8in (ac) Super WiFi Base Station
 Power rating : DC 56V From POE Input AC 120V/60Hz
 Test Mode : IEEE802.11nHT20 2412Hz Tx
 WA8011NAC-H

No.	Freq. (MHz)	Ant. Factor (dB/m)	Cable Loss (dB)	AMP factor (dB)	Reading (dBuV)	Emission Level (dBuV/m)	Limits (dBuV/m)	Margin (dB)	Remark
1	2390.040	27.98	7.28	36.62	54.51	53.15	74.00	20.85	Peak
2	2400.000	28.00	7.32	36.62	81.62	80.32	74.00	-6.32	Peak
3	2417.755	28.04	7.35	36.61	106.70	105.48	74.00	-31.48	Peak

Remarks: 1. Emission Level= Antenna Factor + Cable Loss + Reading - Amp Factor
 2. The emission levels that are 20dB below the official limit are not reported.

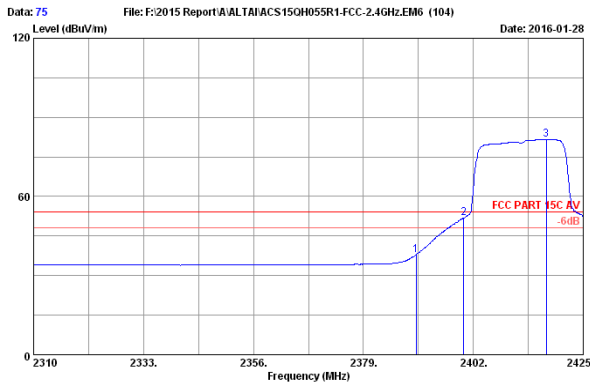

Data: 75 File: F:\2015 Report\A\ALTAIACS150H055R1-FCC-2.4GHz.EM6 (104) Date: 2016-01-28

Site no. : 3m Chamber Data no. : 75
 Dis. / Ant. : 3m 2015 MCTD1209 3006 Ant. pol. : HORIZONTAL
 Limit : FCC PART 15C AV
 Env. / Ins. : 23°C/54%
 Engineer : Leo-Li
 EUT : Aitai A8in (ac) Super WiFi Base Station
 Power rating : DC 56V From POE Input AC 120V/60Hz
 Test Mode : IEEE802.11nHT20 2412Hz Tx
 WA8011NAC-H

No.	Freq. (MHz)	Ant. Factor (dB/m)	Cable Loss (dB)	AMP factor (dB)	Reading (dBuV)	Emission Level (dBuV/m)	Limits (dBuV/m)	Margin (dB)	Remark
1	2390.000	27.98	7.28	36.62	39.23	37.87	54.00	16.13	Average
2	2400.000	28.00	7.32	36.62	53.21	51.91	54.00	2.09	Average
3	2417.295	28.03	7.35	36.61	82.91	81.68	54.00	-27.68	Average

Remarks: 1. Emission Level= Antenna Factor + Cable Loss + Reading - Amp Factor
 2. The emission levels that are 20dB below the official limit are not reported.

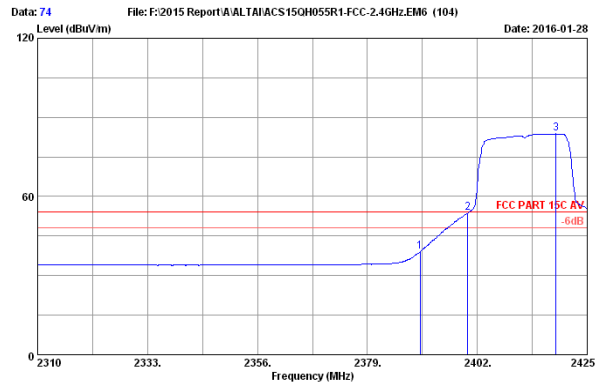

Data: 74 File: F:\2015 Report\A\ALTAIACS150H055R1-FCC-2.4GHz.EM6 (104) Date: 2016-01-28

Site no. : 3m Chamber Data no. : 74
 Dis. / Ant. : 3m 2015 MCTD1209 3006 Ant. pol. : VERTICAL
 Limit : FCC PART 15C AV
 Env. / Ins. : 23°C/54%
 Engineer : Leo-Li
 EUT : Aitai A8in (ac) Super WiFi Base Station
 Power rating : DC 56V From POE Input AC 120V/60Hz
 Test Mode : IEEE802.11nHT20 2412Hz Tx
 WA8011NAC-H

No.	Freq. (MHz)	Ant. Factor (dB/m)	Cable Loss (dB)	AMP factor (dB)	Reading (dBuV)	Emission Level (dBuV/m)	Limits (dBuV/m)	Margin (dB)	Remark
1	2390.000	27.98	7.28	36.62	40.35	38.99	54.00	15.01	Average
2	2400.000	28.00	7.32	36.62	55.14	53.84	54.00	0.16	Average
3	2418.445	28.04	7.35	36.61	84.97	83.75	54.00	-29.75	Average

Remarks: 1. Emission Level= Antenna Factor + Cable Loss + Reading - Amp Factor
 2. The emission levels that are 20dB below the official limit are not reported.

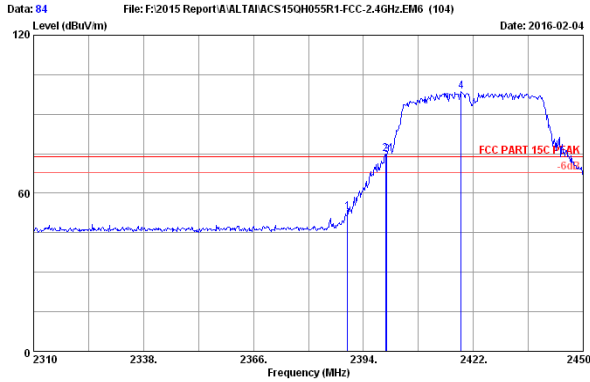

Data: 84 File: F:\2015 Report\A\ALTAIACS150H055R1-FCC-2.4GHz.EM6 (104) Date: 2016-02-04

Site no. : 3m Chamber Data no. : 84
 Dis. / Ant. : 3m 2015 MCTD1209 3006 Ant. pol. : HORIZONTAL
 Limit : FCC PART 15C PEAK
 Env. / Ins. : 23°C/54%
 Engineer : Leo-Li
 EUT : Alcatel A81n (ac) Super WiFi Base Station
 Power rating : DC 56V From POE Input AC 120V/60Hz
 Test Mode : IFEES02.11nHT40 2422Hz Tx
 WA8011NAC-H

No.	Freq. (MHz)	Ant. Factor (dB/m)	Cable Loss (dB)	AMP factor (dB)	Reading (dBuV)	Emission Level (dBuV/m)	Limits (dBuV/m)	Margin (dB)	Remark
1	2390.000	27.98	7.28	36.62	54.11	52.75	74.00	21.25	Peak
2	2399.600	28.00	7.32	36.62	76.18	74.88	74.00	-0.88	Peak
3	2400.000	28.00	7.32	36.62	75.73	74.43	74.00	-0.43	Peak
4	2418.920	28.04	7.35	36.61	99.71	98.49	74.00	-24.49	Peak

Remarks: 1. Emission Level= Antenna Factor + Cable Loss + Reading - Amp Factor
 2. The emission levels that are 20dB below the official limit are not reported.

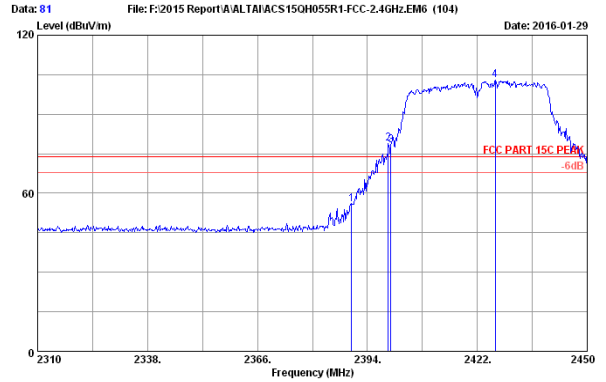

Data: 81 File: F:\2015 Report\A\ALTAIACS150H055R1-FCC-2.4GHz.EM6 (104) Date: 2016-01-29

Site no. : 3m Chamber Data no. : 81
 Dis. / Ant. : 3m 2015 MCTD1209 3006 Ant. pol. : VERTICAL
 Limit : FCC PART 15C PEAK
 Env. / Ins. : 23°C/54%
 Engineer : Leo-Li
 EUT : Alcatel A81n (ac) Super WiFi Base Station
 Power rating : DC 56V From POE Input AC 120V/60Hz
 Test Mode : IFEES02.11nHT40 2422Hz Tx
 WA8011NAC-H

No.	Freq. (MHz)	Ant. Factor (dB/m)	Cable Loss (dB)	AMP factor (dB)	Reading (dBuV)	Emission Level (dBuV/m)	Limits (dBuV/m)	Margin (dB)	Remark
1	2390.000	27.98	7.28	36.62	57.29	55.93	74.00	18.07	Peak
2	2399.320	28.00	7.32	36.62	80.09	78.79	74.00	-4.79	Peak
3	2400.000	28.00	7.32	36.62	79.36	78.06	74.00	-4.06	Peak
4	2426.620	28.05	7.35	36.61	104.10	102.89	74.00	-28.89	Peak

Remarks: 1. Emission Level= Antenna Factor + Cable Loss + Reading - Amp Factor
 2. The emission levels that are 20dB below the official limit are not reported.

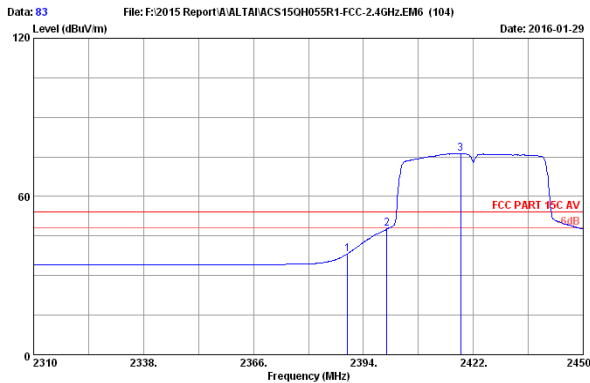

Data: 83 File: F:\2015 Report\A\ALTAIACS150H055R1-FCC-2.4GHz.EM6 (104) Date: 2016-01-29

Site no. : 3m Chamber Data no. : 83
 Dis. / Ant. : 3m 2015 MCTD1209 3006 Ant. pol. : HORIZONTAL
 Limit : FCC PART 15C AV
 Env. / Ins. : 23°C/54%
 Engineer : Leo-Li
 EUT : Alcatel A81n (ac) Super WiFi Base Station
 Power rating : DC 56V From POE Input AC 120V/60Hz
 Test Mode : IFEES02.11nHT40 2422Hz Tx
 WA8011NAC-H

No.	Freq. (MHz)	Ant. Factor (dB/m)	Cable Loss (dB)	AMP factor (dB)	Reading (dBuV)	Emission Level (dBuV/m)	Limits (dBuV/m)	Margin (dB)	Remark
1	2390.000	27.98	7.28	36.62	39.59	38.23	54.00	15.77	Average
2	2400.000	28.00	7.32	36.62	49.00	47.70	54.00	6.30	Average
3	2418.780	28.04	7.35	36.61	77.47	76.25	54.00	-22.25	Average

Remarks: 1. Emission Level= Antenna Factor + Cable Loss + Reading - Amp Factor
 2. The emission levels that are 20dB below the official limit are not reported.

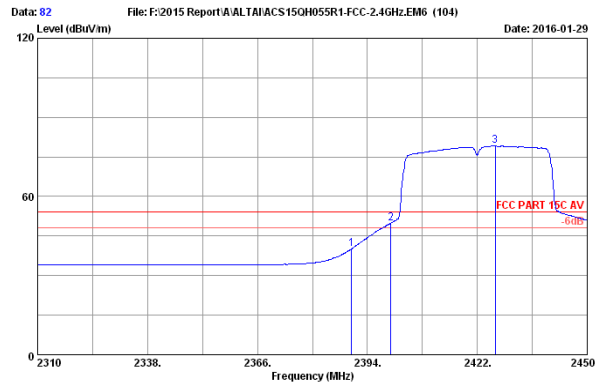

Data: 82 File: F:\2015 Report\A\ALTAIACS150H055R1-FCC-2.4GHz.EM6 (104) Date: 2016-01-29

Site no. : 3m Chamber Data no. : 82
 Dis. / Ant. : 3m 2015 MCTD1209 3006 Ant. pol. : VERTICAL
 Limit : FCC PART 15C AV
 Env. / Ins. : 23°C/54%
 Engineer : Leo-Li
 EUT : Alcatel A81n (ac) Super WiFi Base Station
 Power rating : DC 56V From POE Input AC 120V/60Hz
 Test Mode : IFEES02.11nHT40 2422Hz Tx
 WA8011NAC-H

No.	Freq. (MHz)	Ant. Factor (dB/m)	Cable Loss (dB)	AMP factor (dB)	Reading (dBuV)	Emission Level (dBuV/m)	Limits (dBuV/m)	Margin (dB)	Remark
1	2390.000	27.98	7.28	36.62	41.44	40.08	54.00	13.92	Average
2	2400.000	28.00	7.32	36.62	51.25	49.95	54.00	4.05	Average
3	2426.620	28.05	7.35	36.61	80.31	79.10	54.00	-25.10	Average

Remarks: 1. Emission Level= Antenna Factor + Cable Loss + Reading - Amp Factor
 2. The emission levels that are 20dB below the official limit are not reported.

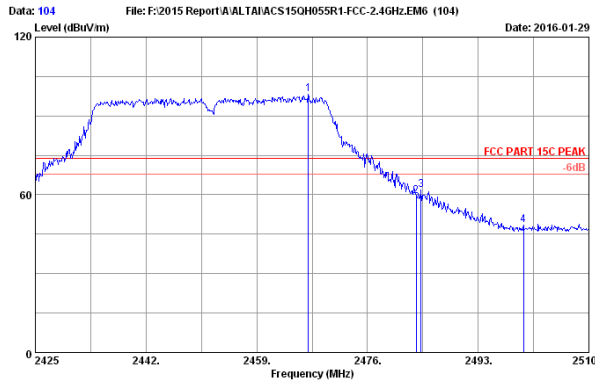

Data: 104 File: F:\2015 Report\A\ALTAIACS150H055R1-FCC-2.4GHz.EM6 (104) Date: 2016-01-29

Site no. : 3m Chamber Data no. : 104
 Dis. / Ant. : 3m 2015 MCTD1209 3006 Ant. pol. : HORIZONTAL
 Limit : FCC PART 15C PEAK
 Env. / Ins. : 23°C/54%
 Engineer : Leo-Li
 EUT : Altai A8in (ac) Super WiFi Base Station
 Power rating : DC 56V From POE Input AC 120V/60Hz
 Test Mode : IEEE802.11nHT40 2452Hz Tx
 WA8011NAC-H

No.	Freq. (MHz)	Ant. Factor (dB/m)	Cable Loss (dB)	AMP factor (dB)	Reading (dBuV)	Emission Level (dBuV/m)	Limits (dBuV/m)	Margin (dB)	Remark
1	2466.905	28.13	7.47	36.59	99.26	98.27	74.00	-24.27	Peak
2	2483.500	28.17	7.51	36.59	60.47	59.56	74.00	14.44	Peak
3	2484.245	28.17	7.51	36.59	62.75	61.84	74.00	12.16	Peak
4	2500.000	28.20	7.51	36.58	49.45	48.58	74.00	25.42	Peak

Remarks: 1. Emission Level= Antenna Factor + Cable Loss + Reading - Amp Factor
 2. The emission levels that are 20dB below the official limit are not reported.

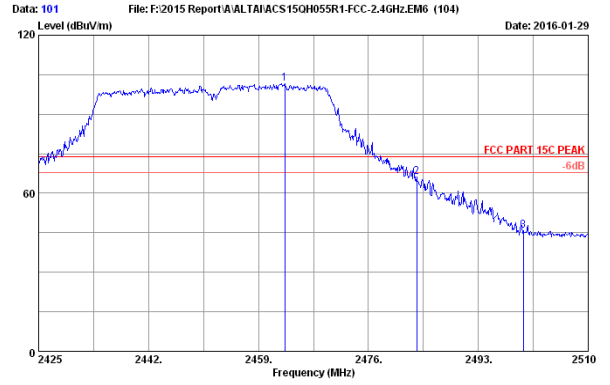

Data: 101 File: F:\2015 Report\A\ALTAIACS150H055R1-FCC-2.4GHz.EM6 (104) Date: 2016-01-29

Site no. : 3m Chamber Data no. : 101
 Dis. / Ant. : 3m 2015 MCTD1209 3006 Ant. pol. : VERTICAL
 Limit : FCC PART 15C PEAK
 Env. / Ins. : 23°C/54%
 Engineer : Leo-Li
 EUT : Altai A8in (ac) Super WiFi Base Station
 Power rating : DC 56V From POE Input AC 120V/60Hz
 Test Mode : IEEE802.11nHT40 2452Hz Tx
 WA8011NAC-H

No.	Freq. (MHz)	Ant. Factor (dB/m)	Cable Loss (dB)	AMP factor (dB)	Reading (dBuV)	Emission Level (dBuV/m)	Limits (dBuV/m)	Margin (dB)	Remark
1	2463.080	28.13	7.43	36.59	102.56	101.53	74.00	-27.53	Peak
2	2483.500	28.17	7.51	36.59	67.12	66.21	74.00	7.79	Peak
3	2500.000	28.20	7.51	36.58	46.53	45.66	74.00	28.34	Peak

Remarks: 1. Emission Level= Antenna Factor + Cable Loss + Reading - Amp Factor
 2. The emission levels that are 20dB below the official limit are not reported.

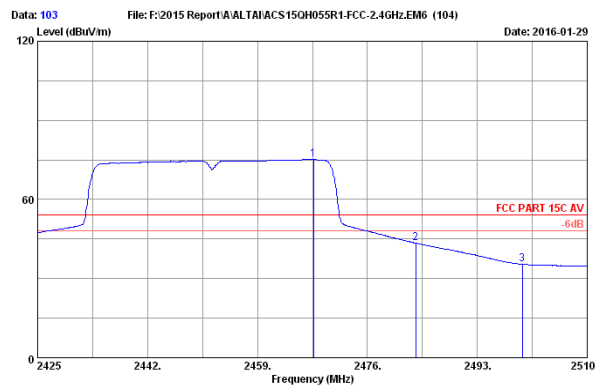

Data: 103 File: F:\2015 Report\A\ALTAIACS150H055R1-FCC-2.4GHz.EM6 (104) Date: 2016-01-29

Site no. : 3m Chamber Data no. : 103
 Dis. / Ant. : 3m 2015 MCTD1209 3006 Ant. pol. : HORIZONTAL
 Limit : FCC PART 15C AV
 Env. / Ins. : 23°C/54%
 Engineer : Leo-Li
 EUT : Altai A8in (ac) Super WiFi Base Station
 Power rating : DC 56V From POE Input AC 120V/60Hz
 Test Mode : IEEE802.11nHT40 2452Hz Tx
 WA8011NAC-H

No.	Freq. (MHz)	Ant. Factor (dB/m)	Cable Loss (dB)	AMP factor (dB)	Reading (dBuV)	Emission Level (dBuV/m)	Limits (dBuV/m)	Margin (dB)	Remark
1	2467.670	28.14	7.47	36.59	76.12	75.14	54.00	-21.14	Average
2	2483.500	28.17	7.51	36.59	44.35	43.44	54.00	10.56	Average
3	2500.000	28.20	7.51	36.58	36.40	35.53	54.00	18.47	Average

Remarks: 1. Emission Level= Antenna Factor + Cable Loss + Reading - Amp Factor
 2. The emission levels that are 20dB below the official limit are not reported.

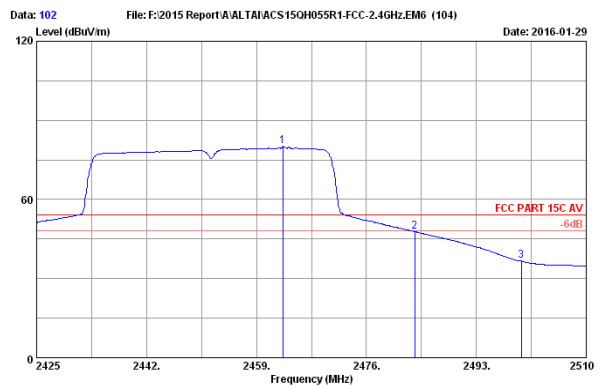

Data: 102 File: F:\2015 Report\A\ALTAIACS150H055R1-FCC-2.4GHz.EM6 (104) Date: 2016-01-29

Site no. : 3m Chamber Data no. : 102
 Dis. / Ant. : 3m 2015 MCTD1209 3006 Ant. pol. : VERTICAL
 Limit : FCC PART 15C AV
 Env. / Ins. : 23°C/54%
 Engineer : Leo-Li
 EUT : Altai A8in (ac) Super WiFi Base Station
 Power rating : DC 56V From POE Input AC 120V/60Hz
 Test Mode : IEEE802.11nHT40 2452Hz Tx
 WA8011NAC-H

No.	Freq. (MHz)	Ant. Factor (dB/m)	Cable Loss (dB)	AMP factor (dB)	Reading (dBuV)	Emission Level (dBuV/m)	Limits (dBuV/m)	Margin (dB)	Remark
1	2463.080	28.13	7.43	36.59	81.18	80.15	54.00	-26.15	Average
2	2483.500	28.17	7.51	36.59	48.68	47.77	54.00	6.23	Average
3	2500.000	28.20	7.51	36.58	37.48	36.61	54.00	17.39	Average

Remarks: 1. Emission Level= Antenna Factor + Cable Loss + Reading - Amp Factor
 2. The emission levels that are 20dB below the official limit are not reported.

7. 6dB Bandwidth Test

7.1. Test Equipment

Item	Equipment	Manufacturer	Model No.	Serial No.	Last Cal.	Cal. Interval
1.	Spectrum	Agilent	N9030A	MY51380221	Oct.18,15	1 Year
2.	Attenuator (20dB)	Agilent	8491B	MY39262165	Apr.28,15	1 Year
3.	RF Cable	Marvelous Microwave Inc	SFL402105FLEX	NO.1	Oct.17.15	1 Year

7.2. Limit

For direct sequence systems, the minimum 6dB bandwidth shall be at least 500kHz

7.3. Test Procedure

The transmitter output was connected to a spectrum analyzer, The bandwidth of the fundamental frequency was measured by spectrum analyzer with 100kHz RBW and 300kHz VBW. The 6dB bandwidth is defined as the total spectrum the power of which is higher than peak power minus 6dB.

7.4. Test Results

EUT: Altai A8in (ac) Super WiFi Base Station		
M/N: WA8011NAC-H		
Test date: 2016-02-20	Pressure: 101.3±1.0kPa	Humidity: 50.1±3.0%
Tested by: Donjon_Huang	Test site: RF site	Temperature: 20.1±0.6 °C

Test Mode	CH	6dB bandwidth (MHz)		Limit (KHz)
		ANT1	ANT2	
11b	CH1	12.58	12.57	≧ 500
	CH6	11.12	12.57	≧ 500
	CH11	12.08	12.58	≧ 500
11g	CH1	16.36	16.41	≧ 500
	CH6	16.34	16.41	≧ 500
	CH11	16.41	16.43	≧ 500
11n HT20	CH1	17.34	17.61	≧ 500
	CH6	17.36	17.62	≧ 500
	CH11	17.62	17.64	≧ 500
11n HT40	CH3	35.72	35.78	≧ 500
	CH6	35.39	35.75	≧ 500
	CH9	36.32	36.37	≧ 500
Conclusion : PASS				

ANT1:

Test Mode: IEEE 802.11b
Test CH1: 2412MHz

Test Mode: IEEE 802.11g
Test CH1: 2412MHz

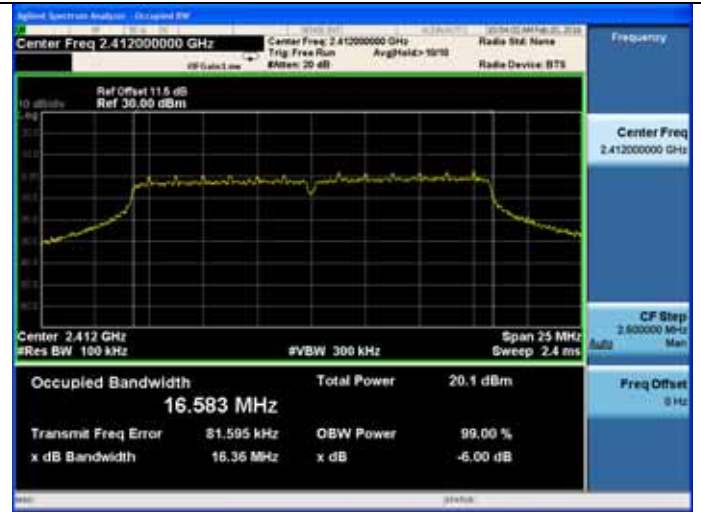

Test CH6: 2437MHz

Test CH6: 2437MHz

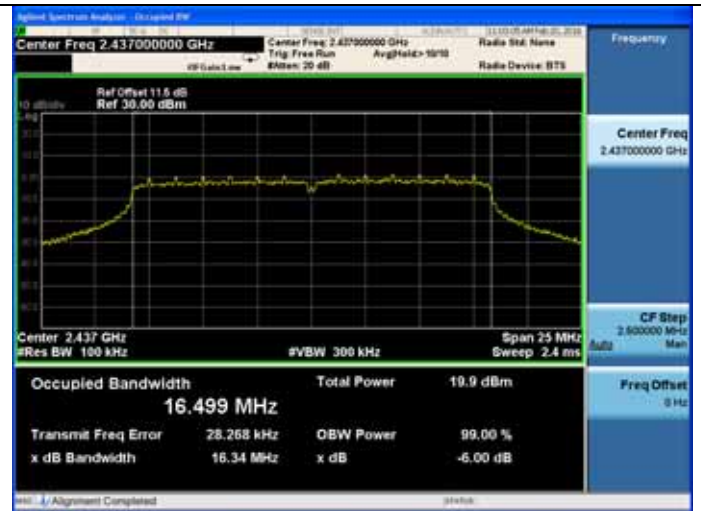

Test CH11: 2462MHz

Test CH11: 2462MHz

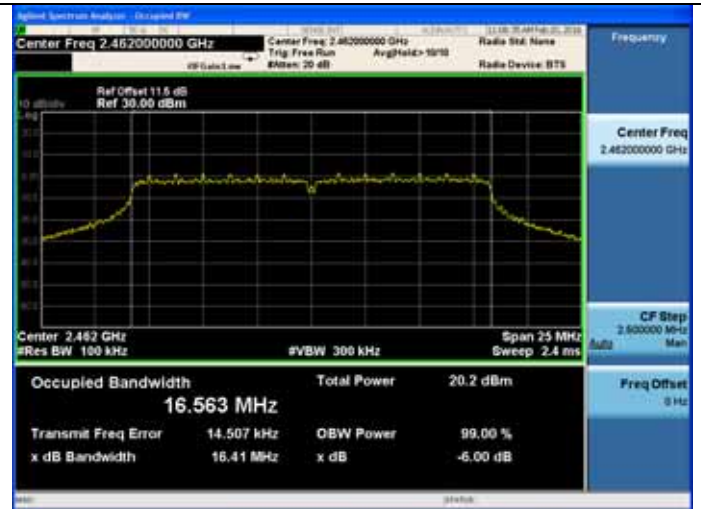

Test Mode: IEEE 802.11n HT20
Test CH1: 2412MHz

Test Mode: IEEE 802.11n HT40
Test CH3: 2422MHz

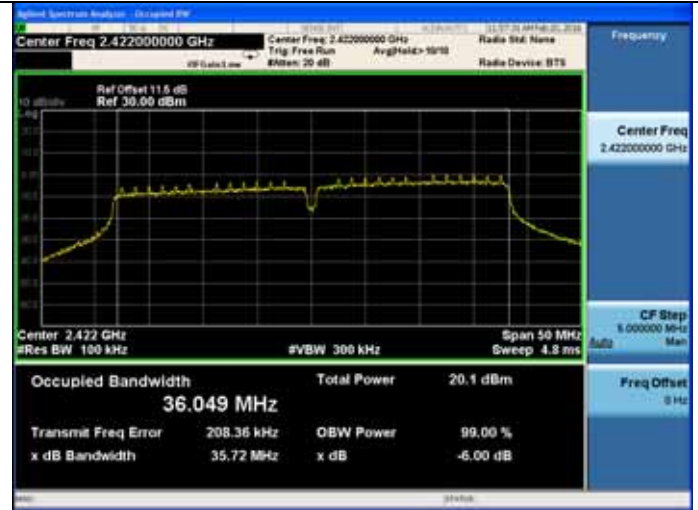
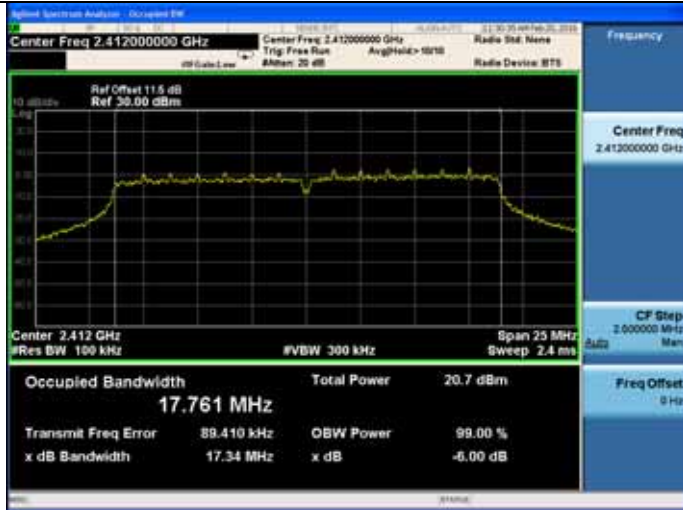

Test CH6: 2437MHz

Test CH6: 2437MHz

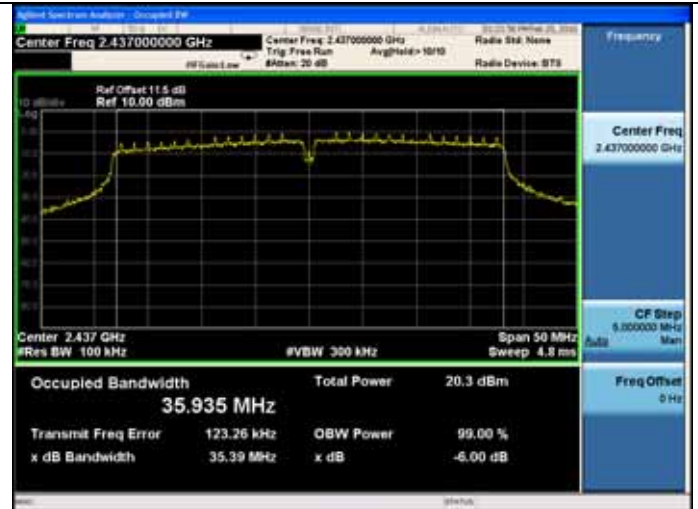
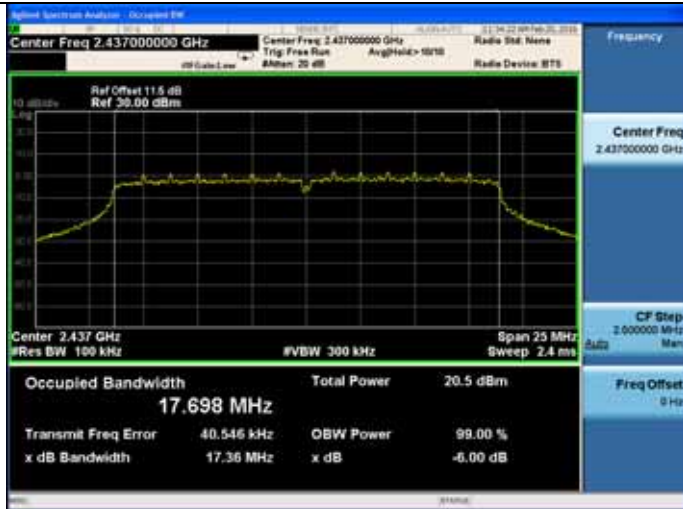

Test CH11: 2462MHz

Test CH9: 2452MHz

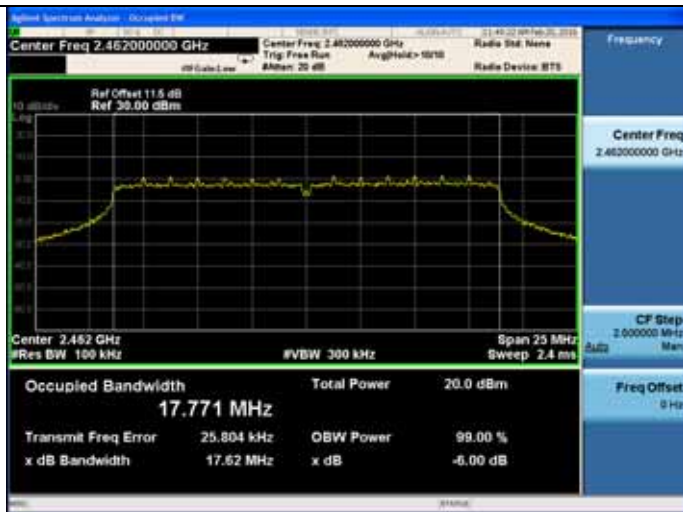

ANT2:

Test Mode: IEEE 802.11b
Test CH1: 2412MHz

Test Mode: IEEE 802.11g
Test CH1: 2412MHz



Test CH6: 2437MHz

Test CH6: 2437MHz

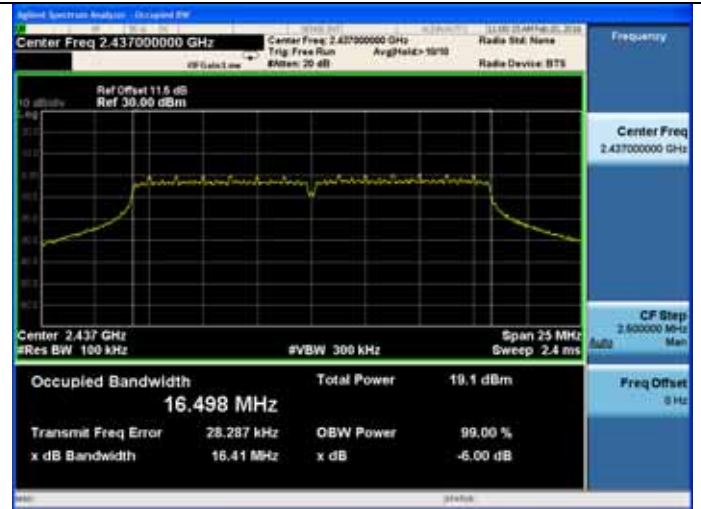

Test CH11: 2462MHz

Test CH11: 2462MHz

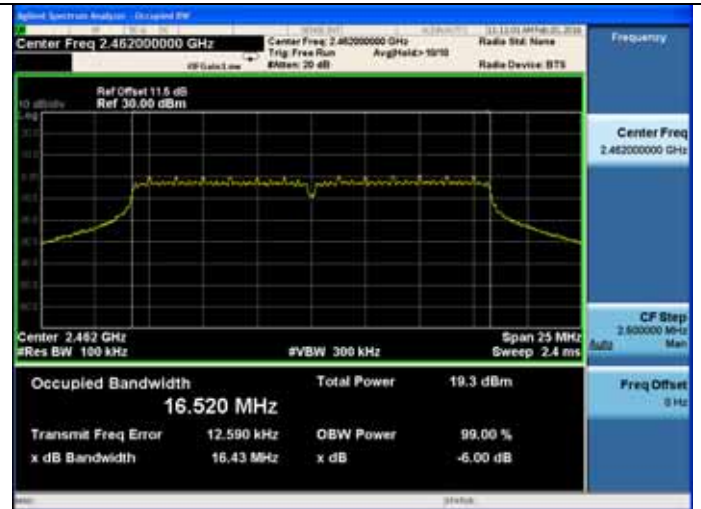

Test Mode: IEEE 802.11n HT20
Test CH1: 2412MHz

Test Mode: IEEE 802.11n HT40
Test CH3: 2422MHz

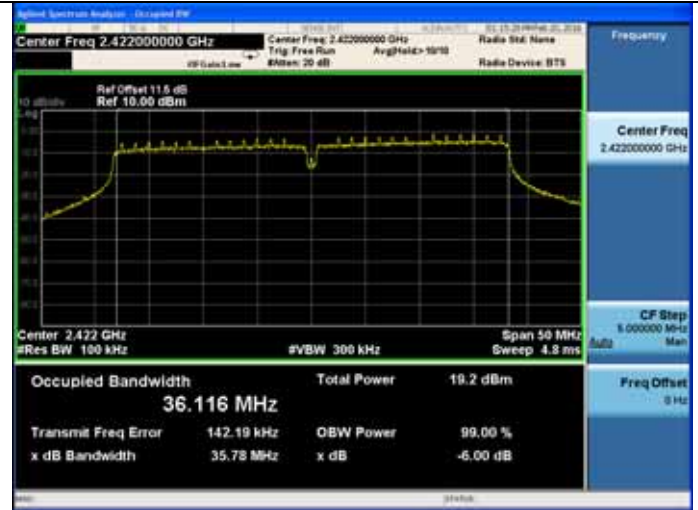
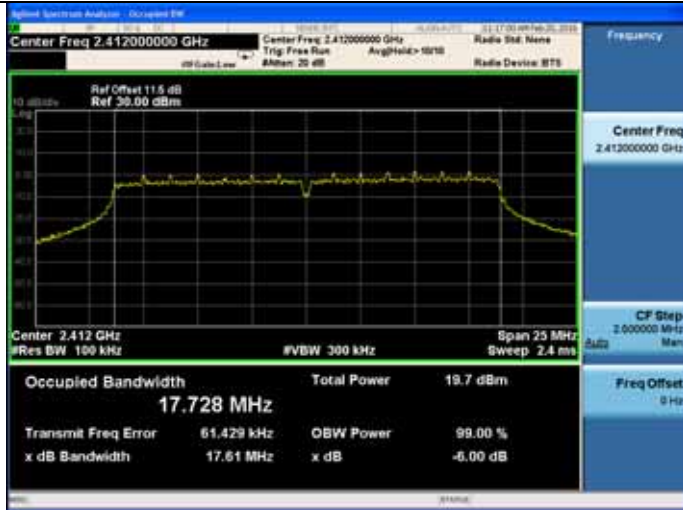

Test CH6: 2437MHz

Test CH6: 2437MHz

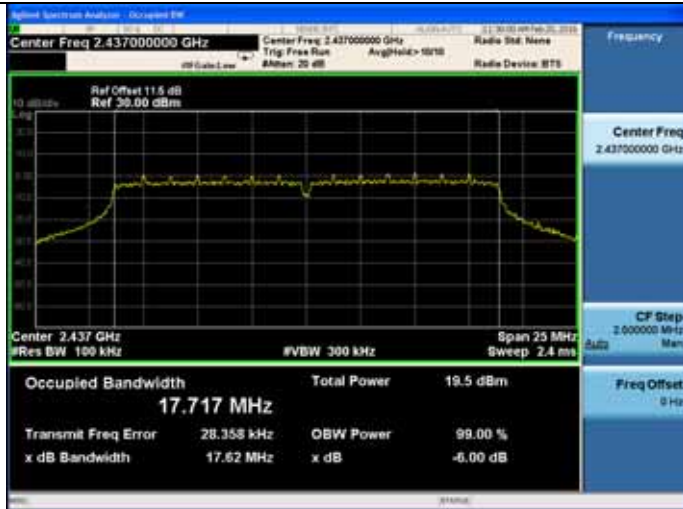

Test CH11: 2462MHz

Test CH9: 2452MHz

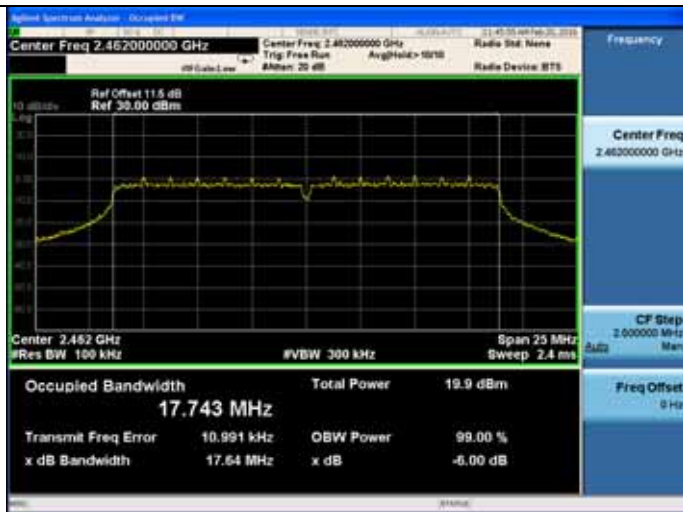

8. OUTPUT POWER TEST

8.1. Test Equipment

Item	Equipment	Manufacturer	Model No.	Serial No.	Last Cal.	Cal. Interval
1.	Spectrum	Agilent	N9030A	MY51380221	Oct.18,15	1 Year
2.	Power meter	Anritsu	ML2487A	6K00002472	Aug.21,15	1 Year
3.	Power sensor	Anritsu	MA2491A	0033005	Aug.21,15	1 Year
4.	Attenuator (20dB)	Agilent	8491B	MY39262165	Apr.28,15	1 Year
5.	RF Cable	Marvelous Microwave Inc	SFL402105FLEX	NO.1	Oct.17,15	1 Year

8.2. Limit (FCC Part 15C 15.247 b (3))

For systems using digital modulation in the 2400—2483.5MHz, The Peak output Power shall not exceed 1W(30dBm), As an alternative to a peak power measurement, compliance with the one Watt limit can be based on a measurement of the maximum conducted output power. Maximum Conducted Output Power is defined as the total transmit power delivered to all antennas and antenna elements averaged across all symbols in the signaling alphabet when the transmitter is operating at its maximum power control level.

8.3. Test Procedure

1. Connected the EUT's antenna port to measure device by 26dB attenuator.
2. For IEEE 802.11b/g and IEEE802.11n HT20 modes, use a power meter which bandwidth is 20MHz, above the bandwidth of signals, to measure out output power in each mode.
3. For IEEE802.11n HT40 mode, since the signal bandwidth is nearly 40MHz, which is above 20MHz bandwidth of power sensor of ML2491A. use the test method descried in KDB558074 clause 9.2.2.
 - 1) Set the RBW=1MHz and VBW =3MHz
 - 2) Set the span at least 1.5 times the OBW
 - 3) Detector = RMS
 - 4) Sweep time = auto couple
 - 5) Allow trace to fully stabilize
 - 6) Use the spectrum analyzer's integrated band power measurement function with band limits set equal to the EBW band edges.

Note: The cable loss and attenuator loss were offset into measure device as an amplitude offset.

8.4. Test Results

Module 1:

EUT: Altai A8in (ac) Super WiFi Base Station					
M/N: WA8011NAC-H					
Test date: 2016-02-20		Pressure: 101.3±1.0kPa		Humidity: 50.3±3.0%	
Tested by: Donjon_Huang		Test site: RF site		Temperature: 20.4±0.6 °C	
Test Mode	CH	output Power (dBm)			Limit (dBm)
		ANT 1	ANT2	Total	
11b	CH1	18.11	18.40	21.27	19
	CH6	18.37	17.75	21.08	19
	CH11	17.99	18.15	21.08	19
11g	CH1	18.34	18.19	21.28	19
	CH6	18.23	18.31	21.28	19
	CH11	18.06	18.54	21.32	19
11n HT20	CH1	18.65	18.15	21.42	19
	CH6	18.56	18.08	21.34	19
	CH11	18.32	18.62	21.48	19
11n HT40	CH3	18.58	17.79	21.21	19
	CH6	18.70	17.90	21.33	19
	CH9	18.75	18.04	21.42	19
Conclusion: PASS					

$$\begin{aligned} \text{Directional Gain} &= G_{\text{ANT}} + 10\log_2(\text{dBi}) \\ &= 14\text{dBi} + 3\text{dBi} \\ &= 17\text{dBi} > 6\text{dBi} \end{aligned}$$

$$\begin{aligned} \text{Output Power Limit} &= 30\text{dBm} - (17\text{dBi} - 6\text{dBi}) \\ &= 19\text{dBm} \end{aligned}$$

Module 2:

EUT: Altai A8in (ac) Super WiFi Base Station					
M/N: WA8011NAC-H					
Test date: 2016-02-20		Pressure: 101.3±1.0kPa		Humidity: 50.3±3.0%	
Tested by: Donjon_Huang		Test site: RF site		Temperature: 20.4±0.6 °C	
Test Mode	CH	output Power (dBm)			Limit (dBm)
		ANT 1	ANT 2	Total	
11b	CH1	17.96	18.04	21.01	19
	CH6	18.12	17.49	20.83	19
	CH11	17.61	17.89	20.76	19
11g	CH1	18.01	17.87	20.95	19
	CH6	17.82	18.11	20.98	19
	CH11	17.84	18.13	21.00	19
11n HT20	CH1	18.21	17.79	21.02	19
	CH6	18.01	17.86	20.95	19
	CH11	17.91	18.26	21.10	19
11n HT40	CH3	18.16	17.60	20.90	19
	CH6	18.30	17.56	20.96	19
	CH9	18.38	18.01	21.21	19
Conclusion: PASS					

$$\begin{aligned}
 \text{Directional Gain} &= G_{\text{ANT}} + 10\log_2(\text{dBi}) \\
 &= 14\text{dBi} + 3\text{dBi} \\
 &= 17\text{dBi} > 6\text{dBi}
 \end{aligned}$$

$$\begin{aligned}
 \text{Output Power Limit} &= 30\text{dBm} - (17\text{dBi} - 6\text{dBi}) \\
 &= 19\text{dBm}
 \end{aligned}$$

Module 3:

EUT: Altai A8in (ac) Super WiFi Base Station					
M/N: WA8011NAC-H					
Test date: 2016-02-20		Pressure: 101.3±1.0kPa		Humidity: 50.3±3.0%	
Tested by: Donjon_Huang		Test site: RF site		Temperature: 20.4±0.6 °C	
Test Mode	CH	output Power (dBm)			Limit (dBm)
		ANT 1	ANT 2	Total	
11b	CH1	17.84	18.14	21.00	19
	CH6	18.02	17.74	20.89	19
	CH11	17.76	18.08	20.93	19
11g	CH1	18.14	17.88	21.02	19
	CH6	17.95	18.05	21.01	19
	CH11	17.86	18.22	21.05	19
11n HT20	CH1	18.31	18.08	21.21	19
	CH6	18.21	17.83	21.03	19
	CH11	18.12	18.27	21.21	19
11n HT40	CH3	18.18	17.55	20.89	19
	CH6	18.10	17.74	20.93	19
	CH9	18.43	17.60	21.05	19
Conclusion: PASS					

$$\begin{aligned}
 \text{Directional Gain} &= G_{\text{ANT}} + 10\log_2(\text{dBi}) \\
 &= 14\text{dBi} + 3\text{dBi} \\
 &= 17\text{dBi} > 6\text{dBi}
 \end{aligned}$$

$$\begin{aligned}
 \text{Output Power Limit} &= 30\text{dBm} - (17\text{dBi} - 6\text{dBi}) \\
 &= 19\text{dBm}
 \end{aligned}$$

Module 4:

EUT: Altai A8in (ac) Super WiFi Base Station					
M/N: WA8011NAC-H					
Test date: 2016-02-20		Pressure: 101.3±1.0kPa		Humidity: 50.3±3.0%	
Tested by: Donjon_Huang		Test site: RF site		Temperature: 20.4±0.6 °C	
Test Mode	CH	output Power (dBm)			Limit (dBm)
		ANT 1	ANT 2	Total	
11b	CH1	18.06	18.08	21.08	19
	CH6	18.12	17.43	20.80	19
	CH11	17.76	18.13	20.96	19
11g	CH1	17.95	18.10	21.04	19
	CH6	17.83	18.24	21.05	19
	CH11	18.31	18.04	21.19	19
11n HT20	CH1	18.28	17.87	21.09	19
	CH6	18.31	17.96	21.15	19
	CH11	18.18	18.21	21.21	19
11n HT40	CH3	18.05	17.91	20.99	19
	CH6	18.53	17.53	21.07	19
	CH9	18.32	18.00	21.17	19
Conclusion: PASS					

$$\begin{aligned}
 \text{Directional Gain} &= G_{\text{ANT}} + 10\log_2(\text{dBi}) \\
 &= 14\text{dBi} + 3\text{dBi} \\
 &= 17\text{dBi} > 6\text{dBi}
 \end{aligned}$$

$$\begin{aligned}
 \text{Output Power Limit} &= 30\text{dBm} - (17\text{dBi} - 6\text{dBi}) \\
 &= 19\text{dBm}
 \end{aligned}$$

Module 1:

ANT1:

Test Mode: IEEE 802.11n HT40
 Test CH3: 2422MHz



ANT2:

Test Mode: IEEE 802.11n HT40
 Test CH3: 2422MHz



Test CH6: 2437MHz



Test CH6: 2437MHz



Test CH9: 2452MHz



Test CH9: 2452MHz



Module 2:

ANT1:

Test Mode: IEEE 802.11n HT40
 Test CH3: 2422MHz



ANT2:

Test Mode: IEEE 802.11n HT40
 Test CH3: 2422MHz



Test CH6: 2437MHz



Test CH6: 2437MHz



Test CH9: 2452MHz



Test CH9: 2452MHz



Module 3:

ANT1:

Test Mode: IEEE 802.11n HT40
 Test CH3: 2422MHz



ANT2:

Test Mode: IEEE 802.11n HT40
 Test CH3: 2422MHz



Test CH6: 2437MHz



Test CH6: 2437MHz



Test CH9: 2452MHz



Test CH9: 2452MHz



Module 4:

ANT1:	ANT2:
--------------	--------------

Test Mode: IEEE 802.11n HT40	Test Mode: IEEE 802.11n HT40
Test CH3: 2422MHz	Test CH3: 2422MHz



Test CH6: 2437MHz	Test CH6: 2437MHz
-------------------	-------------------



Test CH9: 2452MHz	Test CH9: 2452MHz
-------------------	-------------------



9. POWER SPECTRAL DENSITY TEST

9.1. Test Equipment

Item	Equipment	Manufacturer	Model No.	Serial No.	Last Cal.	Cal. Interval
1.	Spectrum	Agilent	N9030A	MY51380221	Oct.18,15	1 Year
2.	Attenuator (20dB)	Agilent	8491B	MY39262165	Apr.28,15	1 Year
3.	RF Cable	Marvelous Microwave Inc	SFL402105FLEX	NO.1	Oct.17,15	1 Year

9.2. Limit

For digitally modulated systems, the power spectral density conducted from the intentional radiator to the antenna shall not be greater than 8dBm in any 3kHz band during any time interval of continuous transmission.

9.3. Test Procedure

1. Connected the EUT's antenna port to spectrum analyzer device by 20dB attenuator.
2. Set span to 1.5 times the DTS Bandwidth.
3. Set the RBW=3KHz, VBW=10KHz.
4. Detector=peak, Sweep time=Auto, Trace mode=max Hold
5. All the trace to fully stabilize.
6. Use the peak marker function to determine the maximum amplitude level with in the RBW.

Note: The cable loss and attenuator loss were offset into measure device as an amplitude

9.4. Test Results

EUT: Altai A8in (ac) Super WiFi Base Station					
M/N: WA8011NAC-H					
Test date: 2016-02-20		Pressure: 101.1±1.0kPa		Humidity: 49.9±3.0%	
Tested by: Donjon_Huang		Test site: RF site		Temperature:20.2±0.6 °C	
Test Mode	CH	Power Density (dBm/3KHz)			Limit (dBm/3KHz)
		ANT 1	ANT 2	Total	
11b	CH1	-6.742	-6.311	-3.51	-3
	CH6	-6.379	-7.631	-3.95	-3
	CH11	-7.309	-6.288	-3.76	-3
11g	CH1	-12.192	-12.702	-9.43	-3
	CH6	-10.979	-12.960	-8.85	-3
	CH11	-11.456	-12.531	-8.95	-3
11n HT20	CH1	-11.239	-12.407	-8.77	-3
	CH6	-11.934	-13.376	-9.59	-3
	CH11	-12.411	-13.088	-9.73	-3
11n HT40	CH3	-14.424	-15.304	-11.83	-3
	CH6	-13.137	-15.372	-11.10	-3
	CH9	-14.764	-15.522	-12.12	-3
Conclusion: PASS					

Note: 11b/g/n

$$\begin{aligned} \text{Directional Gain} &= G_{\text{ANT}} + \text{Array Gain} \\ &= 14\text{dBi} + 10\log_2(\text{dBi}) \\ &= 17\text{dBi} > 6\text{dBi} \end{aligned}$$

$$\begin{aligned} \text{Output Power Limit} &= 8\text{dBm} - (17\text{dBi} - 6\text{dBi}) \\ &= -3\text{dBm} \end{aligned}$$

ANT1:

Test Mode: IEEE 802.11b
Test CH1: 2412MHz



Test Mode: IEEE 802.11g
Test CH1: 2412MHz

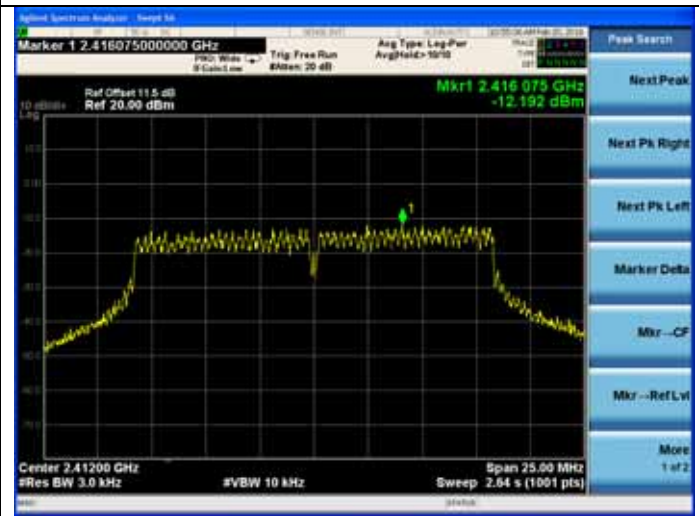

Test CH6: 2437MHz



Test CH6: 2437MHz

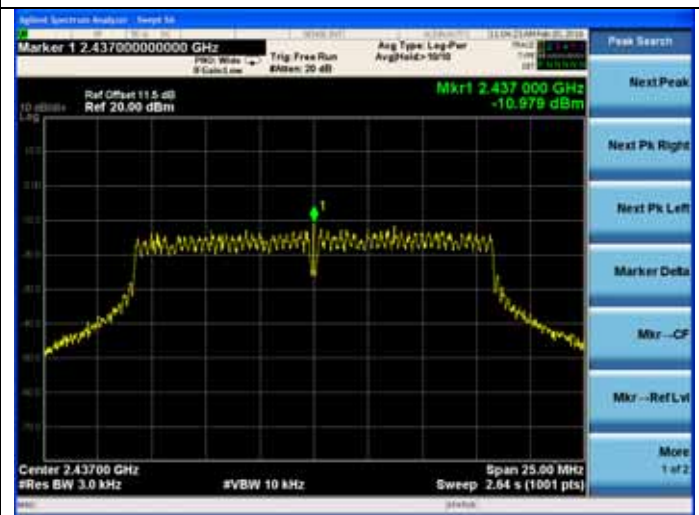

Test CH11: 2462MHz



Test CH11: 2462MHz

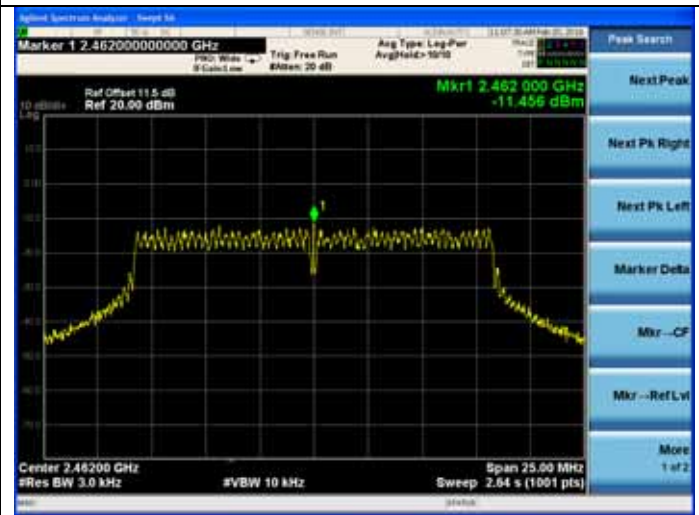

Test Mode: IEEE 802.11n HT20
Test CH1: 2412MHz

Test Mode: IEEE 802.11n HT40
Test CH3: 2422MHz

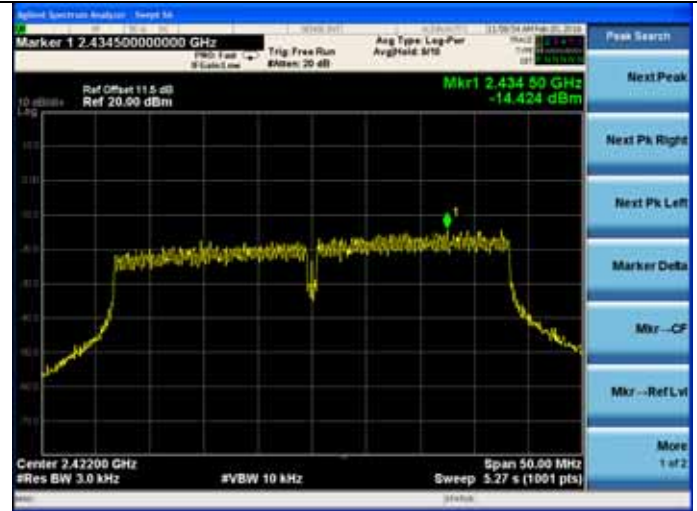

Test CH6: 2437MHz

Test CH6: 2437MHz

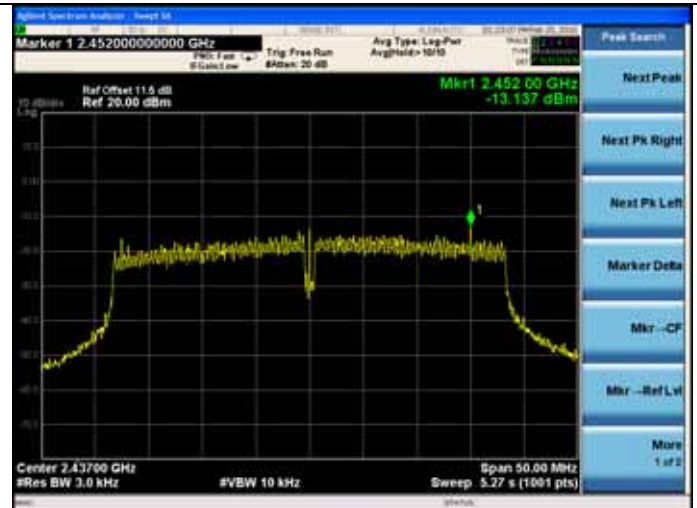
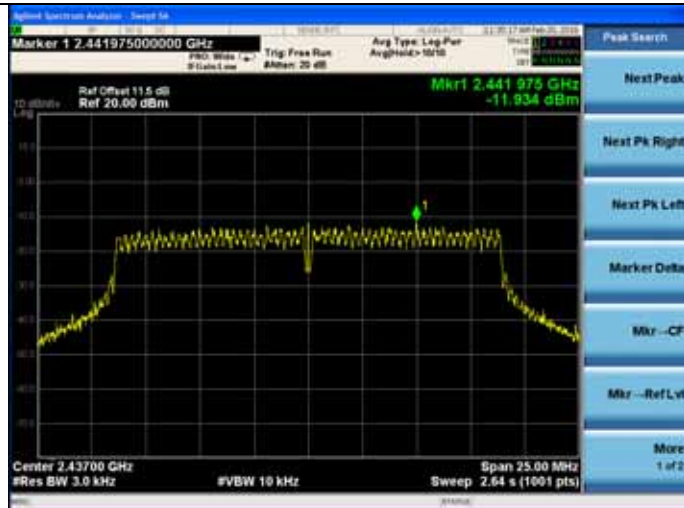

Test CH11: 2462MHz

Test CH9: 2452MHz

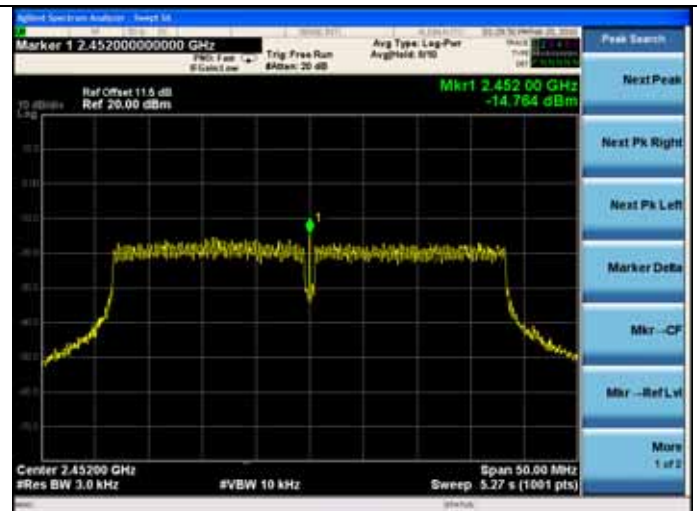
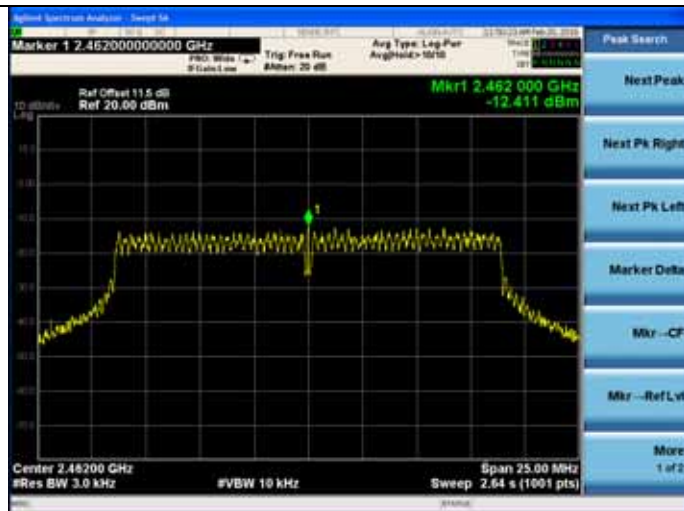

ANT2:

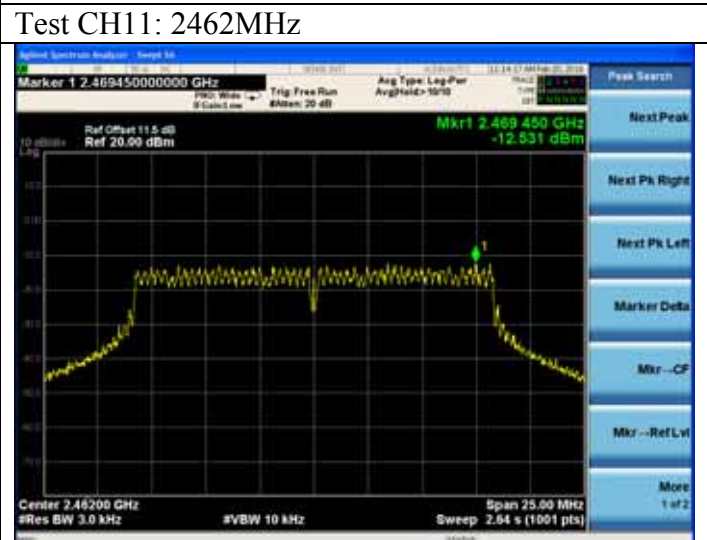
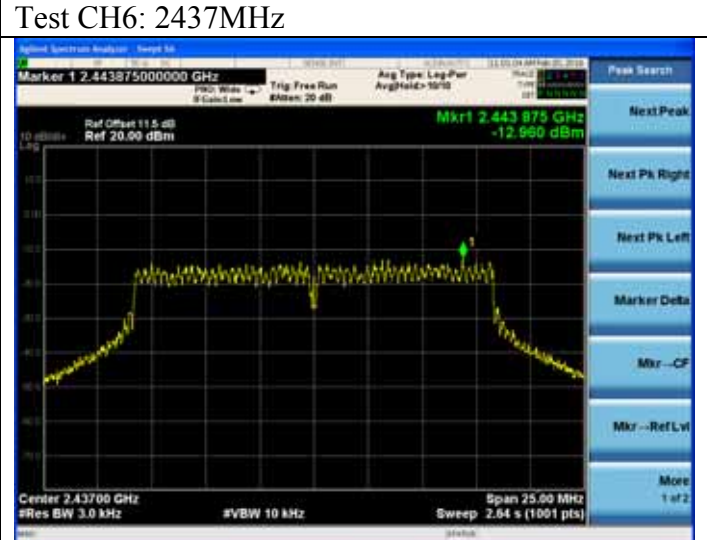
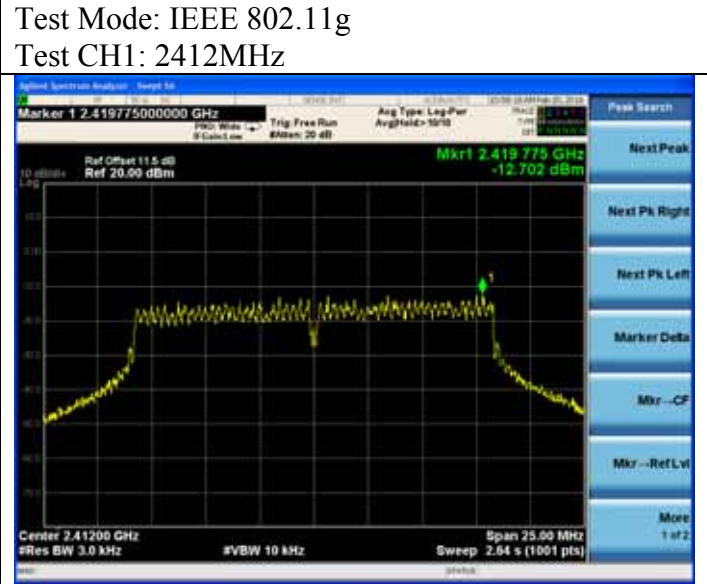
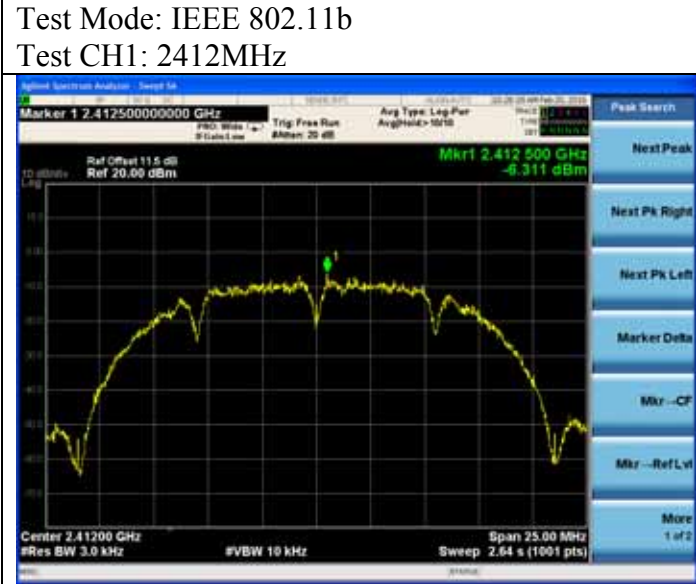

Test Mode: IEEE 802.11n HT20
 Test CH1: 2412MHz

Test Mode: IEEE 802.11n HT40
 Test CH3: 2422MHz

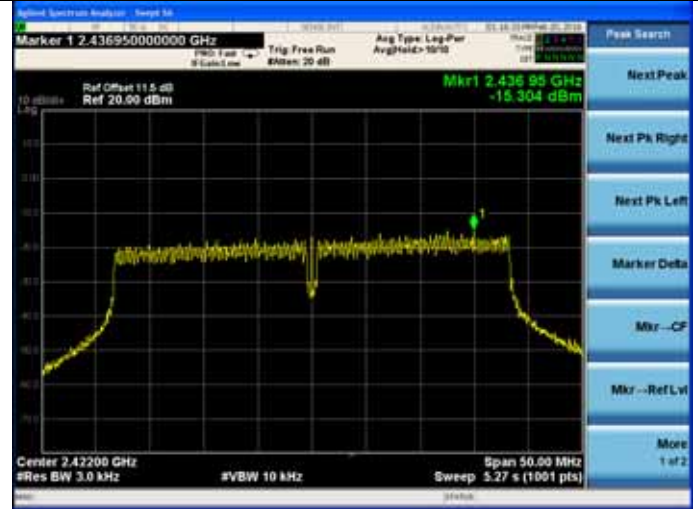
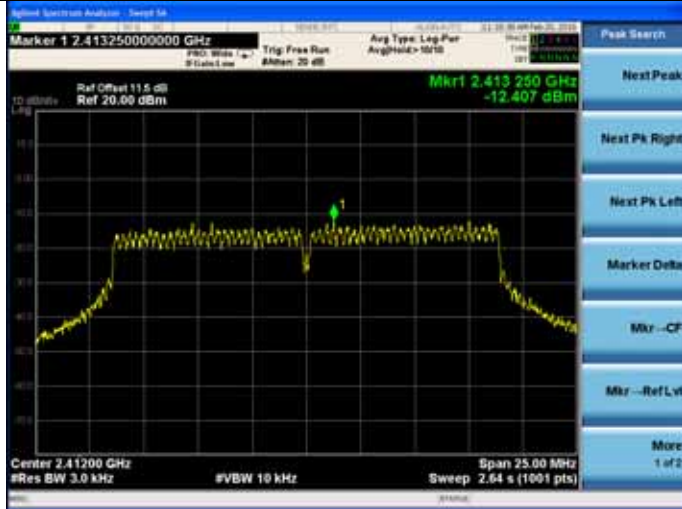

Test CH6: 2437MHz

Test CH6: 2437MHz

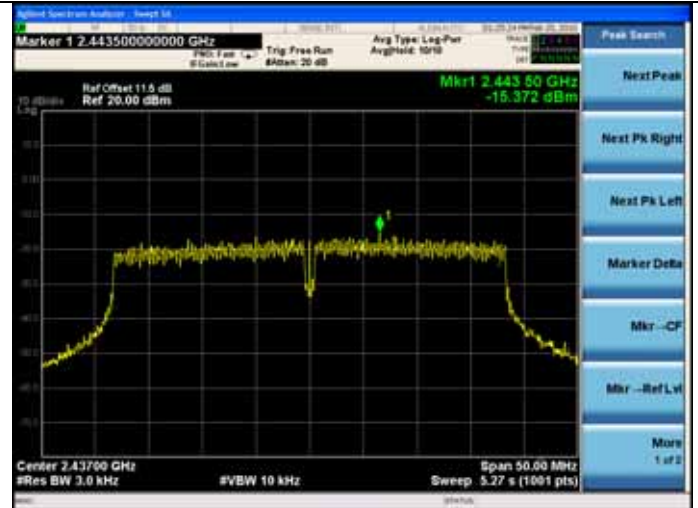
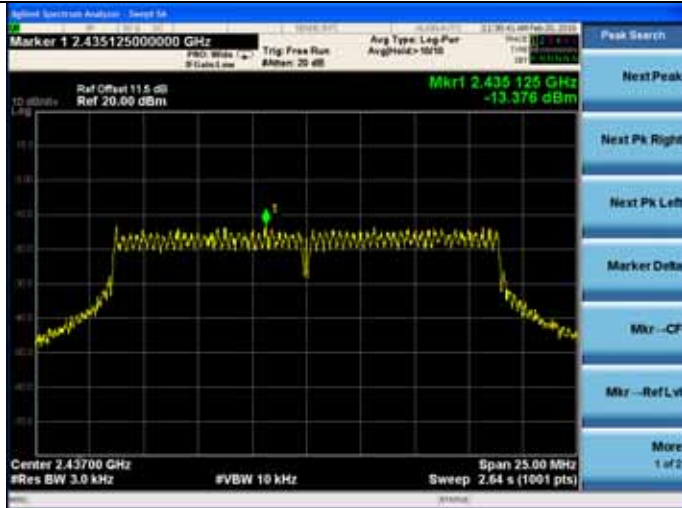

Test CH11: 2462MHz

Test CH9: 2452MHz

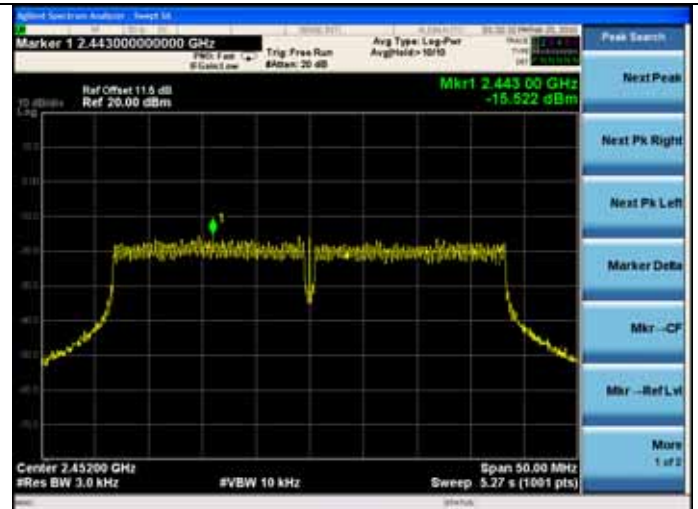
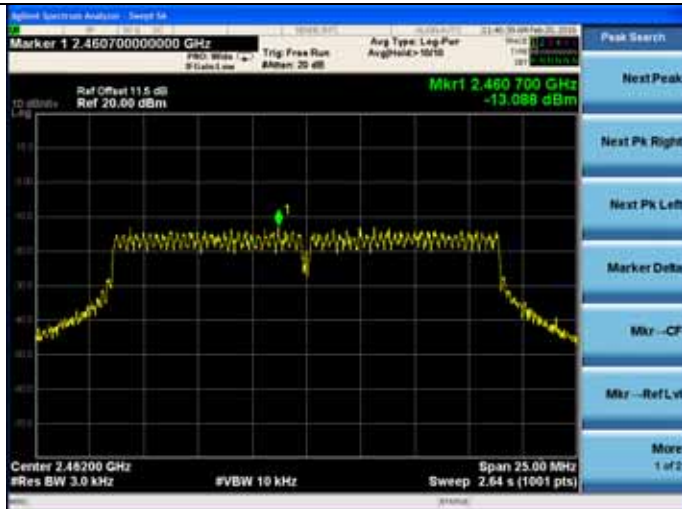

10.MPE ESTIMATION

10.1.Limit for General Population/ Uncontrolled Exposures

Frequency	Power density (mW/ cm ²)	Averaging time(minutes)
300MHz----1.5GHz	F/1500	30
1.5GHz---100GHz	1.0	30

Frequency(MHz)	Power density (mW/ cm ²)	Averaging time(minutes)
2412	1	30
2437	1	30
2462	1	30

Note: F= Frequency in MHz

10.2. Estimation Result

EUT: Altai A8in (ac) Super WiFi Base Station		
M/N: WA8011NAC-H		
Test date: 2016-02-25	Pressure: 101.4±1.0kPa	Humidity: 50.3±3.0%
Tested by: Donjon_Huang	Test site: RF site	Temperature:20.2±0.6 °C

Test Mode	CH	Frequency (MHz)	Peak Output Power (dBm)	Output Power (mW)	Antenna Gain (dBi)	Antenna Gain (Linear)	MPE
11b	CH1	2412	21.27	133.97	14	25.12	0.6698
	CH6	2437	21.08	128.23	14	25.12	0.6411
	CH11	2462	21.08	128.23	14	25.12	0.6411
11g	CH1	2412	21.28	134.28	14	25.12	0.6714
	CH6	2437	21.28	134.28	14	25.12	0.6714
	CH11	2462	21.32	135.52	14	25.12	0.6776
11n HT20	CH1	2412	21.42	138.68	14	25.12	0.6933
	CH6	2437	21.34	136.14	14	25.12	0.6807
	CH11	2462	21.48	140.60	14	25.12	0.7030
11n HT40	CH3	2422	21.21	132.13	14	25.12	0.6606
	CH6	2437	21.33	135.83	14	25.12	0.6791
	CH9	2452	21.42	138.68	14	25.12	0.6933

$$MPE = \frac{PG}{4\pi R^2} \quad (R=20cm)$$

11. ANTENNA REQUIREMENT

11.1. Standard Applicable

For intentional device, according to FCC 47 CFR Section 15.203, an intentional radiator shall be designed to ensure that no antenna other than that furnished by the responsible party shall be used with the device. And according to FCC 47 CFR Section 15.247 (b), if transmitting antennas of directional gain greater than 6dBi are used, the power shall be reduced by the amount in dB that the directional gain of the antenna exceeds 6dBi.

11.2. Antenna Connected Construction

The antennas used for this product are Sector antenna that no antenna other than that furnished by the responsible party shall be used with the device, the maximum peak gain of the transmit antenna is 14dBi.

12.DEVIATION TO TEST SPECIFICATIONS

[NONE]