



APPLICATION OF CERTIFICATION
For

Altai Technologies Limited

A8-Ein Super WiFi Base Station

Model Number: WA8011N

FCC ID: UCC-WA8011N

Prepared for : Altai Technologies Limited
Units209, 2/F, Lakeside 2, 10 Science Park West Avenue, Hong
Kong Science Park, Shatin, Hong Kong, China

Prepared By: Audix Technology (Shenzhen) Co., Ltd.
No. 6, Ke Feng Rd., 52 Block,
Shenzhen Science & Industrial Park,
Nantou, Shenzhen, Guangdong, China

Tel: (0755) 26639496
Fax: (0755) 26632877

Report Number : ACS- F12256
Date of Test : Nov.24, 2012
Date of Report : Jan.27, 2013

TABLE OF CONTENTS

Description	Page
Test Report Certification	
1. SUMMARY OF STANDARDS AND RESULTS	1-1
1.1. Description of Standards and Results	1-1
2. GENERAL INFORMATION.....	2-1
2.1. Equipment under test (EUT).....	2-1
2.2. Tested Supporting System Details	2-2
2.3. Block Diagram of Test Setup.....	2-2
2.4. Test Facility	2-3
2.5. Measurement Uncertainty (95% confidence levels, k=2).....	2-3
3. POWER LINE CONDUCTED EMISSION MEASUREMENT	3-1
3.1. Test Equipment.....	3-1
3.2. Block Diagram of Test Setup.....	3-1
3.3. Power Line Conducted Emission Test Limits	3-1
3.4. Configuration of EUT on Test.....	3-1
3.5. Operating Condition of EUT	3-2
3.6. Test Procedure	3-2
3.7. Conducted Emission at Mains Terminals Test Results.....	3-2
4. RADIATED EMISSION TEST	4-1
4.1. Test Equipment.....	4-1
4.2. Block Diagram of Test Setup.....	4-1
4.3. Radiated Emission Limit	4-2
4.4. EUT Configuration on Test	4-2
4.5. Operating Condition of EUT	4-2
4.6. Test Procedure	4-3
4.7. Radiated Disturbance Test Results	4-3
5. DEVIATION TO TEST SPECIFICATIONS	5-1
6. PHOTOGRAPH	6-1
6.1. Photos of Power Line Conducted Emission Test.....	6-1
6.2. Photos of Radiated Emission Test	6-2
7. PHOTOS OF THE EUT	7-1

TEST REPORT CERTIFICATION

Applicant : Altai Technologies Limited
Manufacturer : Altai Technologies Limited
EUT Description : A8-Ein Super WiFi Base Station
FCC ID : UCC-WA8011N
(A) Model No. : WA8011N
(B) Power Supply : DC 56V
(C) Test Voltage : DC 56V From Adapter Input AC 120V/60Hz

Measurement Standard Used:

FCC Rules and Regulations Part 15 Subpart B Class B 2011

The device described above is tested by AUDIX TECHNOLOGY (SHENZHEN) CO., LTD. to determine the maximum emission levels emanating from the device. The maximum emission levels are compared to the FCC Part 15 Subpart B Class B limits both conducted and radiated emissions. The test results are contained in this test report and AUDIX TECHNOLOGY (SHENZHEN) CO., LTD. is assumed of full responsibility for the accuracy and completeness of these tests. This report contains data that are not covered by the NVLAP accreditation.

After the test, our opinion is that EUT compliance with the requirement of the above standards.

This Report is made under FCC Part 2.1075. No modifications were required during testing to bring this product into compliance.

This report applies to above tested sample only. This report shall not be reproduced in parts without written approval of AUDIX TECHNOLOGY (SHENZHEN) CO., LTD.

The report must not be used by the client to claim product certification, approval, or endorsement by NVLAP, NIST, or any agency of the federal government.

Date of Test : Nov.24, 2012 Report of date: Jan.27, 2013Prepared by : June shao Reviewed by : [Signature]
June Shao/ Assistant Sunny Lu / Assistant ManagerApproved & Authorized Signer : [Signature]
Ken Lu / Manager

1. SUMMARY OF STANDARDS AND RESULTS

1.1. Description of Standards and Results

The EUT have been tested according to the applicable standards as referenced below.

EMISSION			
Description of Test Item	Standard	Results	Remarks
Power Line Conducted Emission Test	FCC Part 15: 2011 ANSI C63.4: 2009	PASS	Meets Class B Limit Minimum passing margin is 6.97dB at 0.35400MHz
Radiated Emission Test (30-1000MHz)	FCC Part 15: 2011 ANSI C63.4: 2009	PASS	Meets Class B Limit Minimum passing margin is 3.93dB at 31.940MHz
Radiated Emission Test (1-6GHz)	FCC Part 15: 2011 ANSI C63.4: 2009	PASS	Meets Class B Limit Minimum passing margin is 13.63dB at 4835.000MHz

2. GENERAL INFORMATION

2.1. Equipment under test (EUT)

Product Name	: A8-Ein Super WiFi Base Station
Model Number	: WA8011N
FCC ID	: UCC-WA8011N
Operation Frequency	: IEEE 802.11b: 2412MHz—2462MHz IEEE 802.11g: 2412MHz—2462MHz IEEE 802.11n HT20:2412MHz—2462MHz IEEE 802.11n HT20: 5745MHz—5825MHz IEEE 802.11n HT40: 2422MHz—2452MHz IEEE 802.11n HT40: 5755MHz—5795MHz IEEE 802.11a: 5.745GHz—5.825GHz
Channel Number	: IEEE 802.11b/g: 11 Channels IEEE 802.11n HT20 2.4GHz : 11 Channels IEEE 802.11n HT40 2.4GHz band: 7Channels IEEE 802.11n HT20 5.7GHz band : 5Channels IEEE 802.11n HT40 5.7GHz band: 2Channels IEEE 802.11a 5.7GHz band :5Channels
Modulation Technology	: IEEE 802.11b: DSSS(CCK,DQPSK,DBPSK) IEEE 802.11g: OFDM(64QAM, 16QAM, QPSK, BPSK) IEEE 802.11n :OFDM(64QAM, 16QAM, QPSK, BPSK) IEEE 802.11a: OFDM (64QAM, 16QAM, QPSK,BPSK)
Antenna Assembly Gain	: 2.4GHz: Dipole Antenna 19dBi 5.8GHz:Dipole Antenna 20dBi
Applicant	: Altai Technologies Limited Units209, 2/F, Lakeside 2, 10 Science Park West Avenue, Hong Kong Science Park, Shatin, Hong Kong, China
Manufacturer	: Altai Technologies Limited Units209, 2/F, Lakeside 2, 10 Science Park West Avenue, Hong Kong Science Park, Shatin, Hong Kong, China
Power Adapter	: Manufacturer: FSGREAT M/N: GRT-560110A S/N : 120940004
Date of Test	: Aug.22~Nov.25, 2012
Date of Receipt	: Aug.20, 2012
Sample Type	: Prototype production

2.2. Tested Supporting System Details

No.	Description	ACS No.	Manufacturer	Model	Serial Number	Approved type
1	Notebook#1	Test PC M	DELL	PP21L	224XK2X	<input checked="" type="checkbox"/> FCC DoC
2	Notebook#2	Test PC R	DELL	D430	PP09S	<input checked="" type="checkbox"/> FCC DoC <input checked="" type="checkbox"/> BSMI ID: R41108

2.3. Block Diagram of Test Setup

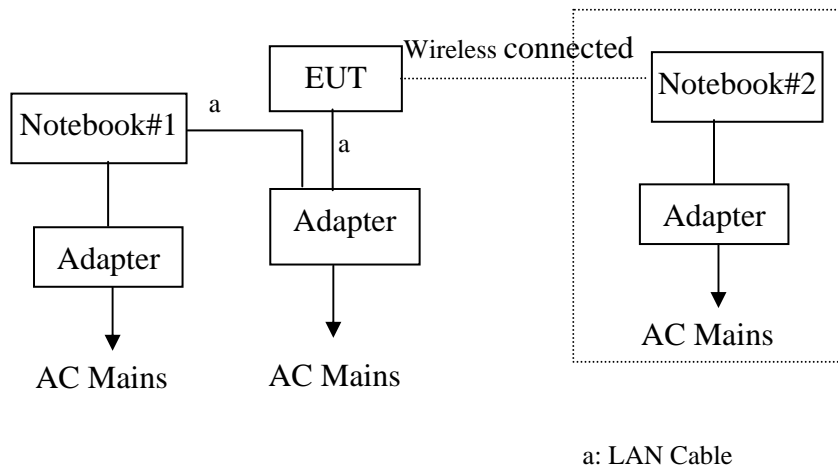

(EUT: A8-Ein Super WiFi Base Station)

2.4. Test Facility

Site Description

- Name of Firm : Audix Technology (Shenzhen) Co., Ltd.
No. 6, Ke Feng Rd., 52 Block, Shenzhen Science & Industrial Park, Nantou, Shenzhen, Guangdong, China
- 3m Anechoic Chamber : Certificated by FCC, USA
Registration Number: 90454
Valid Date: Feb.22, 2015
- 3m & 10m Anechoic Chamber : Certificated by FCC, USA
Registration Number: 794232
Valid Date: Oct.31, 2015
- EMC Lab. : Certificated by DAkkS, Germany
Registration No: D-PL-12151-01-01
Valid Date: Feb.01, 2014
- Accredited by NVLAP, USA
NVLAP Code: 200372-0
Valid Date: Mar.31, 2013

2.5. Measurement Uncertainty (95% confidence levels, k=2)

Test Item	Uncertainty
Uncertainty for Conduction emission test in No. 1 Conduction	3.2 dB
Uncertainty for Radiation Emission test in 3m chamber	3.6 dB(30~200MHz, Polarize: H)
	3.8 dB(30~200MHz, Polarize: V)
	4.2 dB(200M~1GHz, Polarize: H)
	3.8 dB(200M~1GHz, Polarize: V)
Uncertainty for Radiation Emission test in 3m chamber (1GHz-18GHz)	3.1dB(Distance: 3m Polarize: V)
	3.7 dB(Distance: 3m Polarize: H)
Uncertainty for test site temperature and humidity	3%
	0.6°C

3. POWER LINE CONDUCTED EMISSION MEASUREMENT

3.1. Test Equipment

Item	Equipment	Manufacturer	Model No.	Serial No.	Last Cal.	Cal. Interval
1.	Test Receiver	Rohde & Schwarz	ESHS10	838693/001	Oct.31, 12	1 Year
2.	L.I.S.N.#1	Rohde & Schwarz	ESH2-Z5	834066/011	Oct.31, 12	1 Year
3.	L.I.S.N.#3	Kyoritsu	KNW-242C	8-1920-1	May.08, 12	1 Year
4.	Terminator	Hubersuhner	50Ω	No. 1	May.08, 12	1 Year
5.	Terminator	Hubersuhner	50Ω	No. 2	May.08, 12	1 Year
6.	RF Cable	Fujikura	3D-2W	No.1	May.08, 12	1 Year
7.	Coaxial Switch	Anritsu	MP59B	M50564	May.08, 12	1 Year
8.	Pulse Limiter	Rohde & Schwarz	ESH3-Z2	100341	May.08, 12	1 Year

3.2. Block Diagram of Test Setup

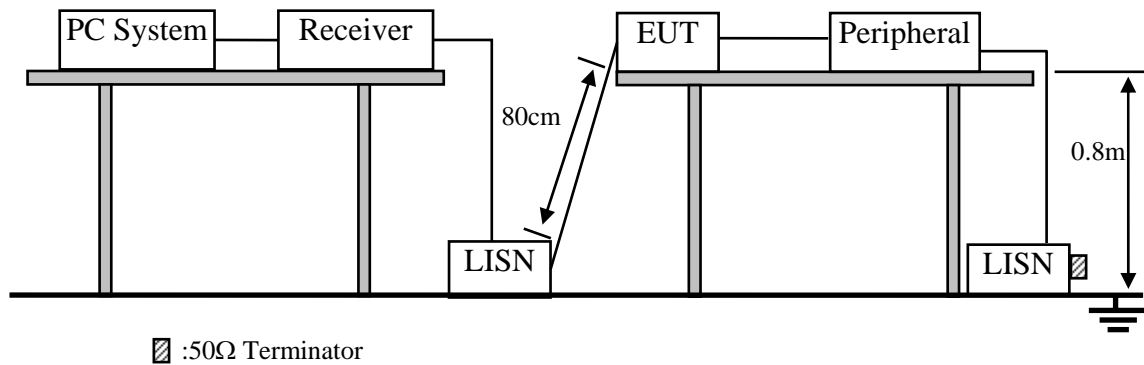

3.3. Power Line Conducted Emission Test Limits

Frequency	Maximum RF Line Voltage	
	Quasi-Peak Level dB(μV)	Average Level dB(μV)
150kHz ~ 500kHz	66 ~ 56*	56 ~ 46*
500kHz ~ 5MHz	56	46
5MHz ~ 30MHz	60	50

- Notes: 1. * Decreasing linearly with logarithm of frequency.
2. The lower limit shall apply at the transition frequencies.

3.4. Configuration of EUT on Test

The following equipment are installed on Power Line Conducted Emission Test to meet the commission requirement and operating regulations in a manner which tends to maximize its emission characteristics in a normal application.

3.4.1. A8-Ein Super WiFi Base Station (EUT)

Model Number : WA8011N
Serial Number : N/A

3.4.2. Support Equipment : As Tested Supporting System Detail, in Section 2.2.

3.5. Operating Condition of EUT

- 3.5.1. Setup the EUT and simulator as shown as Section 3.2.
- 3.5.2. Turn on the power of all equipment..
- 3.5.3. PC run test software to control EUT work in Tx mode.

3.6. Test Procedure

The EUT was placed on a non-metallic table, 80cm above the ground plane. The EUT Power connected to the power mains through a line impedance stabilization network (L.I.S.N. 1#). This provided a 50-ohm coupling impedance for the EUT (Please refer to the block diagram of the test setup and photographs). The other peripheral devices power cord connected to the power mains through a line impedance stabilization network (L.I.S.N.#3). Both sides of power line were checked for maximum conducted interference. In order to find the maximum emission, the relative positions of equipments and all of the interface cables were changed according to ANSI C63.4: 2009 on conducted Emission test.

The bandwidth of test receiver (R&S TEST RECEIVER ESHS10) is set at 9kHz.

The frequency range from 150kHz to 30MHz is checked. The test result are reported on Section 3.7.

3.7. Conducted Emission at Mains Terminals Test Results

PASS. (All emissions not reported below are too low against the prescribed limits.)

The EUT with the following test modes were tested and selected to read Q.P values and average values, all the test results are listed in next pages.

EUT: A8-Ein Super WiFi Base Station Model No. : WA8011N

Test Date:Nov.24, 2012 Temperature: 22.9°C Humidity: 45%

the details of test modes are as follows :

No.	Test Mode	Reference Test Data No.	
		LINE	NEUTRAL
1.	Running	#38	#37

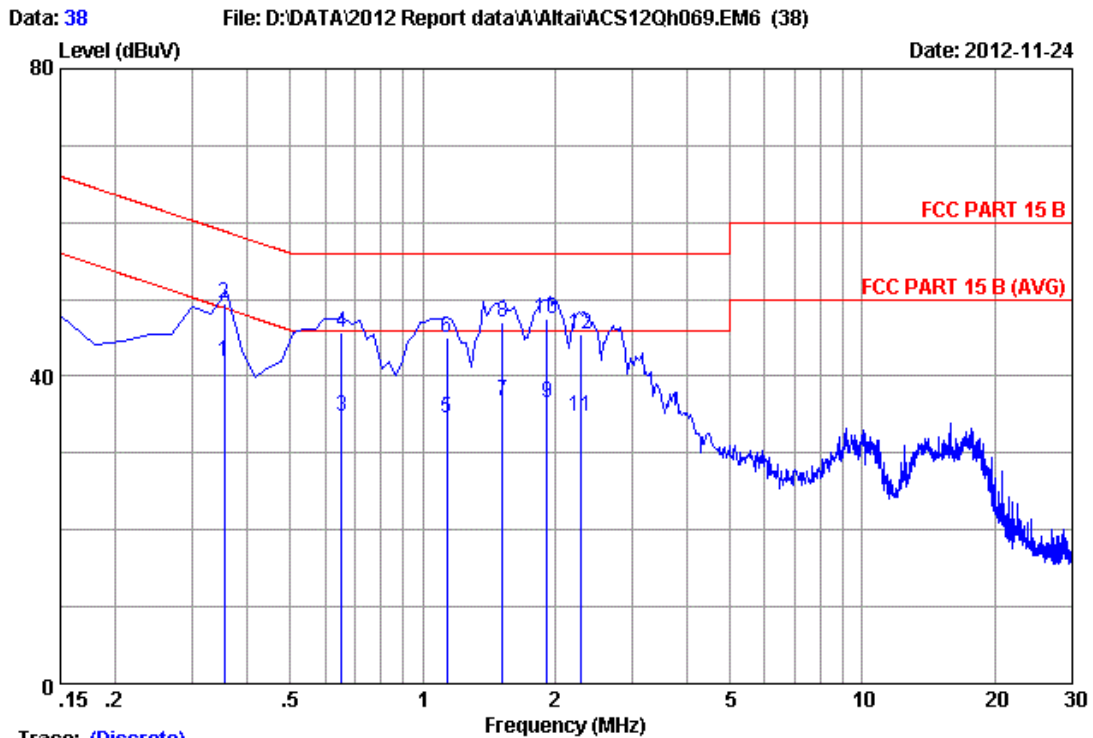

Trace: (Discrete)

Site no :1#conduction Data No :38
 Dis./Ant. :** 2012 ESH2-25 LINE
 Limit :FCC PART 15 B
 Env./Ins. :22.9°C/45% Engineer :Leo-Li
 EUT :A8-Ein Super WiFi Base Station
 Power Rating :DC 56V From Adapter Input AC 230V/50Hz
 Test Mode :Running
 M/N:WA8011N

No	Freq (MHz)	LISN Factor (dB)	Cable Loss (dB)	Reading (dBuV)	Emission Level (dBuV)	Limits (dBuV)	Margin (dB)	Remark
1	0.35400	0.16	9.95	31.79	41.90	48.87	6.97	Average
2	0.35400	0.16	9.95	39.29	49.40	58.87	9.47	QP
3	0.65300	0.16	9.95	24.60	34.71	46.00	11.29	Average
4	0.65300	0.16	9.95	35.60	45.71	56.00	10.29	QP
5	1.136	0.18	9.94	24.39	34.51	46.00	11.49	Average
6	1.136	0.18	9.94	34.79	44.91	56.00	11.09	QP
7	1.520	0.19	9.94	26.70	36.83	46.00	9.17	Average
8	1.520	0.19	9.94	36.90	47.03	56.00	8.97	QP
9	1.920	0.20	9.94	26.50	36.64	46.00	9.36	Average
10	1.920	0.20	9.94	37.30	47.44	56.00	8.56	QP
11	2.280	0.21	9.94	24.69	34.84	46.00	11.16	Average
12	2.280	0.21	9.94	35.29	45.44	56.00	10.56	QP

Remarks: 1.Emission Level=LISN Factor+Cable Loss(Include 10dB pulse limit)+Reading.
 2.If the average limit is met when using a quasi-peak detector, the EUT shall be deemed to meet both limits and measurement with average detector is unnecessary.

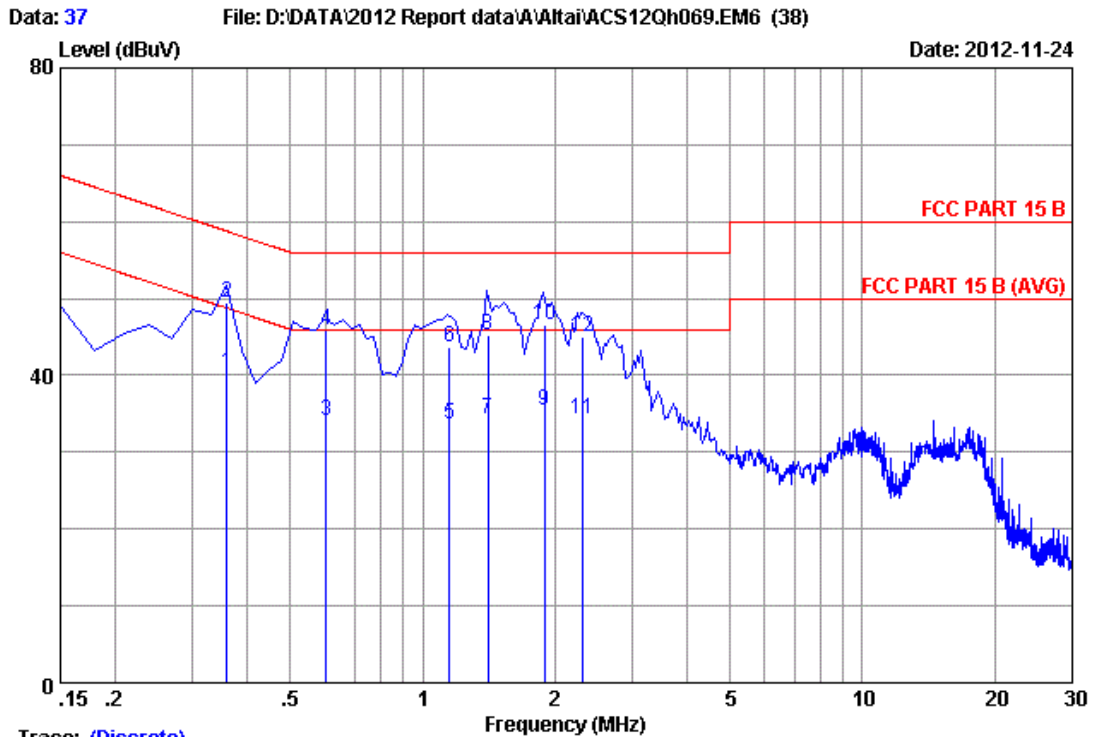

Trace: (Discrete)

Site no :1#conduction Data No :37
 Dis./Ant. :** 2012 ESH2-Z5 NEUTRAL
 Limit :FCC PART 15 B
 Env./Ins. :22.9*C/45% Engineer :Leo-Li
 EUT :A8-Ein Super WiFi Base Station
 Power Rating :DC 56V From Adapter Input AC 230V/50Hz
 Test Mode :Running
 M/N:WA8011N

No	Freq (MHz)	LISN Factor (dB)	Cable Loss (dB)	Reading (dBUV)	Emission Level (dBUV)	Limits (dBUV)	Margin (dB)	Remark
1	0.35800	0.15	9.95	30.19	40.29	48.77	8.48	Average
2	0.35800	0.15	9.95	39.29	49.39	58.77	9.38	QP
3	0.60400	0.16	9.95	24.09	34.20	46.00	11.80	Average
4	0.60400	0.16	9.95	35.89	46.00	56.00	10.00	QP
5	1.149	0.18	9.94	23.60	33.72	46.00	12.28	Average
6	1.149	0.18	9.94	33.60	43.72	56.00	12.28	QP
7	1.410	0.18	9.94	24.30	34.42	46.00	11.58	Average
8	1.410	0.18	9.94	35.10	45.22	56.00	10.78	QP
9	1.890	0.20	9.94	25.20	35.34	46.00	10.66	Average
10	1.890	0.20	9.94	36.50	46.64	56.00	9.36	QP
11	2.310	0.21	9.94	24.19	34.34	46.00	11.66	Average
12	2.310	0.21	9.94	34.89	45.04	56.00	10.96	QP

Remarks: 1.Emission Level=LISN Factor+Cable Loss(Include 10dB pulse limit)+Reading.
 2.If the average limit is met when using a quasi-peak detector, the EUT shall be deemed to meet both limits and measurement with average detector is unnecessary.

4. RADIATED EMISSION TEST

4.1. Test Equipment

4.1.1. For frequency range 30MHz~1000MHz

Item	Equipment	Manufacturer	Model No.	Serial No.	Last Cal.	Cal. Interval
1	3#Chamber	AUDIX	N/A	N/A	Nov.28,11	1 Year
2	EMI Spectrum	Agilent	E4407B	MY41440292	May.08, 12	1 Year
3	Test Receiver	Rohde & Schwarz	ESVS10	834468/011	May.08, 12	1 Year
4	Amplifier	HP	8447D	2648A04738	May.08, 12	1 Year
5	Bilog Antenna	Schaffner	CBL6111C	2598	Dec.26, 10	2.0 Year
6	RF Cable	MIYAZAKI	CFD400-NL	3# Chamber No.1	May.08, 12	1 Year
7	Coaxial Switch	Anritsu	MP59B	M74389	May.08, 12	1 Year

4.1.2. For frequency range 1GHz~6GHz

Item	Equipment	Manufacturer	Model No.	Serial No.	Last Cal.	Cal. Interval
1	Spectrum Analyzer	Agilent	E4407B	MY41440292	May.08, 12	1 Year
2	Horn Antenna	EMCO	3115	9510-4580	June.05, 12	1 Year
3	Amplifier	Agilent	8449B	3008A00863	May.08, 12	1 Year
4	RF Cable	Hubersuhner	SUCOFLEX106	77980/6	May.08, 12	1 Year
5	RF Cable	Hubersuhner	SUCOFLEX106	77977/6	May.08, 12	1 Year
6	Horn Antenna	EMCO	3116	00060089	May.08, 12	1.5Year

4.2. Block Diagram of Test Setup

For frequency range 30MHz-1000Mz

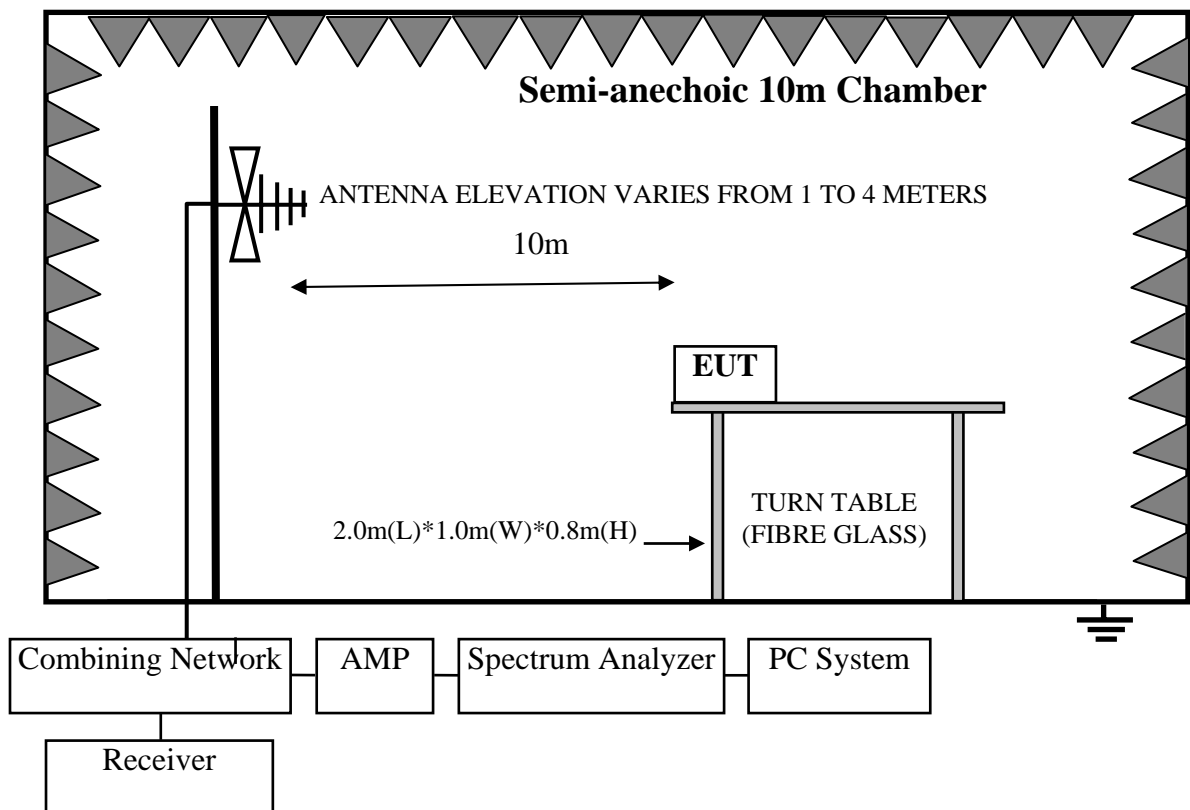

For frequency range 1GHz-25GHz

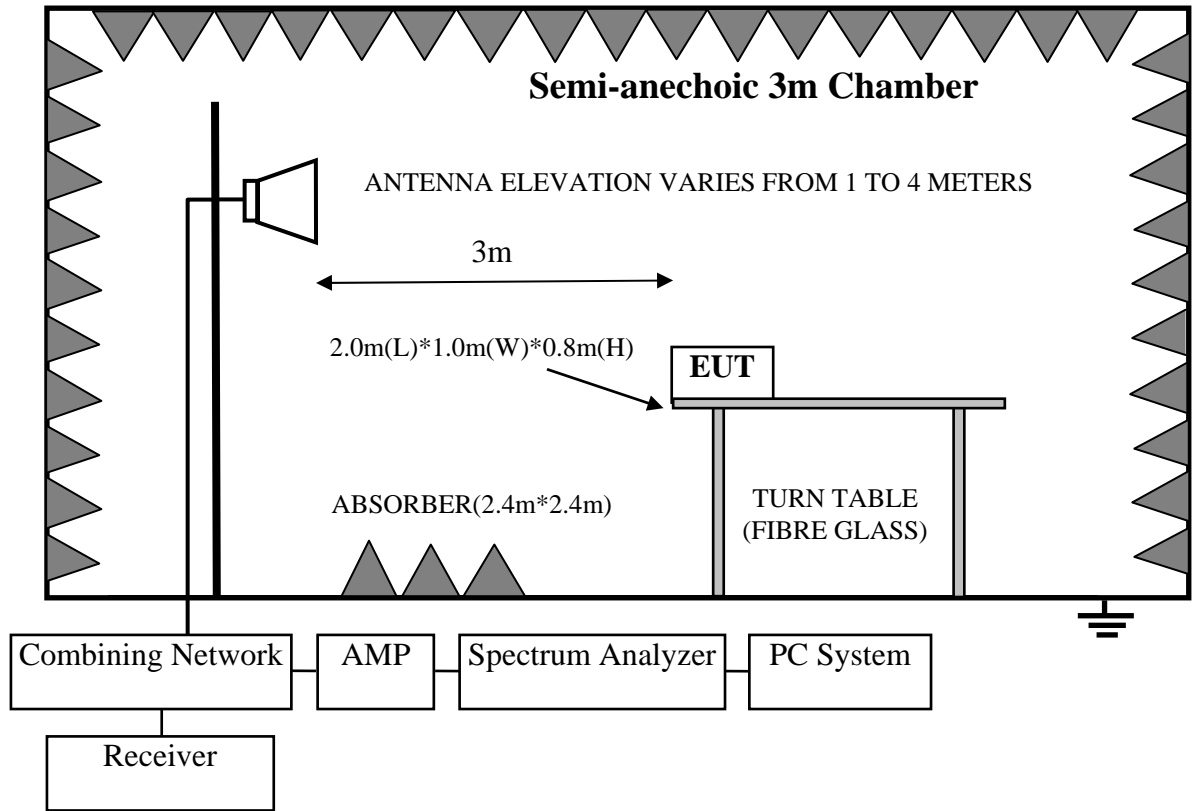

4.3. Radiated Emission Limit

Frequency MHz	Distance (Meters)	Field Strengths Limits dB(μV)/m
30 ~ 88	3	40.0
88 ~ 216	3	43.5
216 ~ 960	3	46.0
960 ~ 1000	3	54.0
Above 1000	3	74(Peak)54(Average)

- Remark: (1) Emission level = Antenna Factor + Cable Loss + Reading
 Emission level = Antenna Factor - Amp Factor + Cable Loss + Reading (above 1000MHz)
- (2) The smaller limit shall apply at the cross point between two frequency bands.
- (3) Distance is the distance in meters between the measuring instrument, antenna and the closest point of any part of the device or system.

4.4. EUT Configuration on Test

The configurations of EUT are listed in Section 3.4

4.5. Operating Condition of EUT

Same as Conducted Emission test that is listed in Section 3.5. except the test set up replaced by Section 4.2.

4.6. Test Procedure

The EUT was placed on a non-metallic table, 80 cm above the ground plane inside a semi-anechoic chamber. An antenna was located 3m from the EUT on an adjustable mast. A pre-scan was first performed in order to find prominent radiated emissions. For final emissions measurements at each frequency of interest, the EUT were rotated and the antenna height was varied between 1m and 4m in order to maximize the emission. Measurements in both horizontal and vertical polarities were made and the data was recorded. In order to find the maximum emission, the relative positions of equipments and all of the interface cables were changed according to ANSI C63.4: 2009 on Radiated Emission test.

The bandwidth of the EMI test receiver (R&S ESVS10) is set at 120kHz for frequency range from 30MHz to 1000 MHz.

The bandwidth of the Spectrum's RBW is set at 1MHz and VBW is set at 3MHz for peak emissions measurement above 1GHz and 1MHz RBW, 10Hz VBW for average emissions measure above 1GHz.

4.7. Radiated Disturbance Test Results

PASS. (All emissions not reported below are too low against the prescribed limits.)

EUT: A8-Ein Super WiFi Base Station
Model No. : WA8011N

For frequency range 30MHz~1000MHz

The EUT with the following test modes were tested and selected to read Q.P values, all the test results are listed in next pages.

Test Date: Nov.24, 2012 Temperature: 24°C Humidity: 56%

The details of test modes are as follows :

No.	Test Mode	Reference Test Data No.	
		Horizontal	Vertical
1.※	Running	#8	#7

For frequency range 1GHz~6GHz

The EUT with below test mode were measured within Anechoic Chamber and the test results listed in next pages

Note: For all the emissions above 1GHz, the peak measured level comply with peak limit, so the average level were deemed to comply with average limit.

Test Date: Nov.24, 2012 Temperature: 24°C Humidity: 56%

The details of test modes are as follows :

No.	Test Mode	Reference Test Data No.	
		Horizontal	Vertical
1.※	Running	#9	#10

30MHz~1000MHz

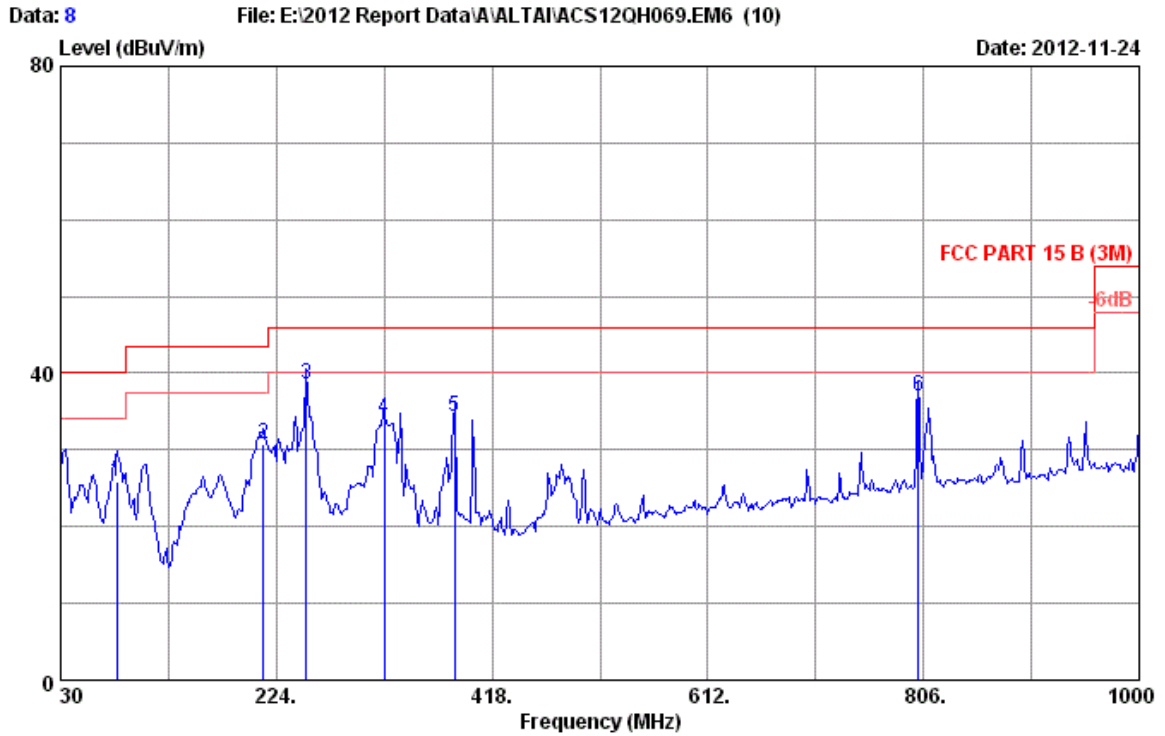

Site no. : 3m Chamber Data no. : 8
 Dis. / Ant. : 3m 2012 CBL6111C 2598 Ant. pol. : HORIZONTAL
 Limit : FCC PART 15 B (3M)
 Env. / Ins. : 24°C/56% Engineer : Leo-Li
 EUT : A8-Ein Super WiFi Base Station
 Power rating : DC 56V From Adapter Input AC 120V/60Hz
 Test Mode : Running
 M/N:WA8011N

No.	Freq. (MHz)	Ant. Factor (dB/m)	Cable Loss (dB)	Reading (dBUV)	Emission Level (dBUV/m)	Limits (dBUV/m)	Margin (dB)	Remark
1	80.440	7.11	0.76	17.98	25.85	40.00	14.15	QP
2	212.360	9.77	1.09	19.85	30.71	43.50	12.79	QP
3	251.160	12.78	1.18	24.60	38.56	46.00	7.44	QP
4	321.000	14.27	1.33	18.59	34.19	46.00	11.81	QP
5	384.050	16.08	1.52	16.69	34.29	46.00	11.71	QP
6	801.150	22.73	2.70	11.54	36.97	46.00	9.03	QP

Remarks: 1. Emission Level= Antenna Factor + Cable Loss + Reading.
 2. The emission levels that are 20dB below the official limit are not reported.

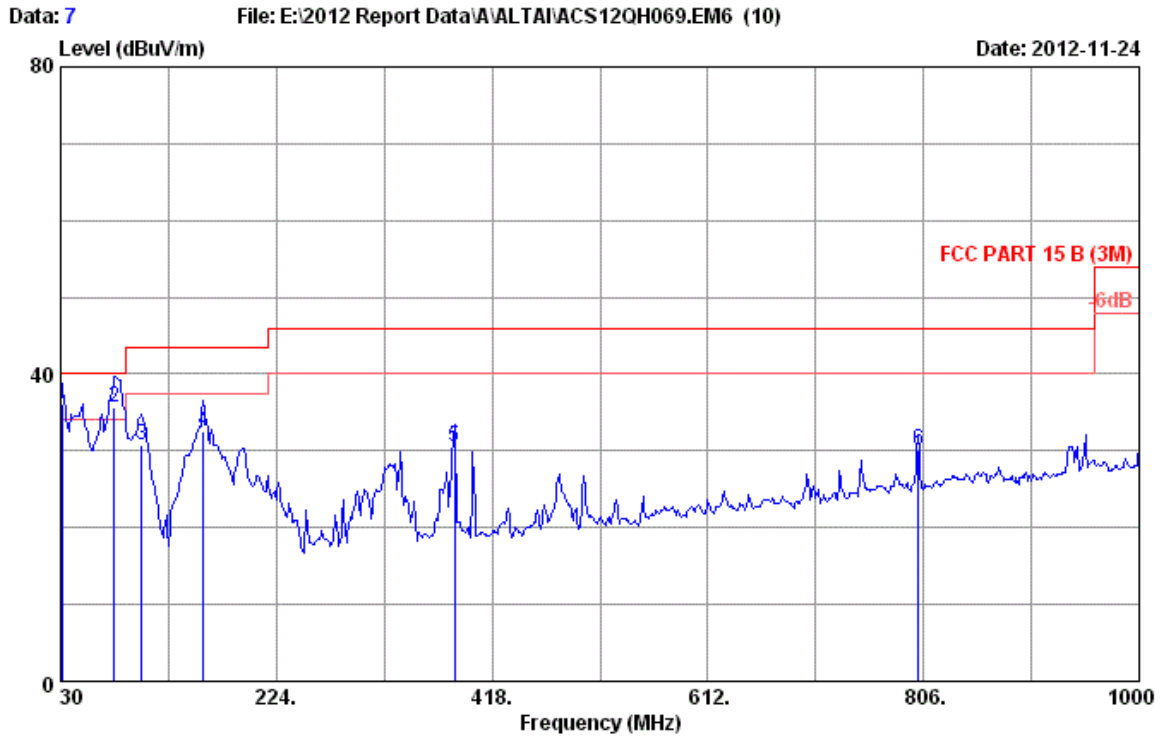

Site no. : 3m Chamber Data no. : 7
 Dis. / Ant. : 3m 2012 CBL6111C 2598 Ant. pol. : VERTICAL
 Limit : FCC PART 15 B (3M)
 Env. / Ins. : 24°C/56% Engineer : Leo-Li
 EUT : A8-Ein Super WiFi Base Station
 Power rating : DC 56V From Adapter Input AC 120V/60Hz
 Test Mode : Running
 M/N:WA8011N

No.	Freq. (MHz)	Ant. Factor (dB/m)	Cable Loss (dB)	Reading (dBUV)	Emission Level (dBUV/m)	Limits (dBUV/m)	Margin (dB)	Remark
1	31.940	17.61	0.45	18.01	36.07	40.00	3.93	QP
2	78.500	6.93	0.76	28.04	35.73	40.00	4.27	QP
3	102.750	9.88	0.85	19.97	30.70	43.50	12.80	QP
4	158.040	10.62	0.97	21.02	32.61	43.50	10.89	QP
5	384.050	16.08	1.52	12.83	30.43	46.00	15.57	QP
6	801.150	22.73	2.70	4.66	30.09	46.00	15.91	QP

Remarks: 1. Emission Level= Antenna Factor + Cable Loss + Reading.
 2. The emission levels that are 20dB below the official limit are not reported.

1GHz~6GHz

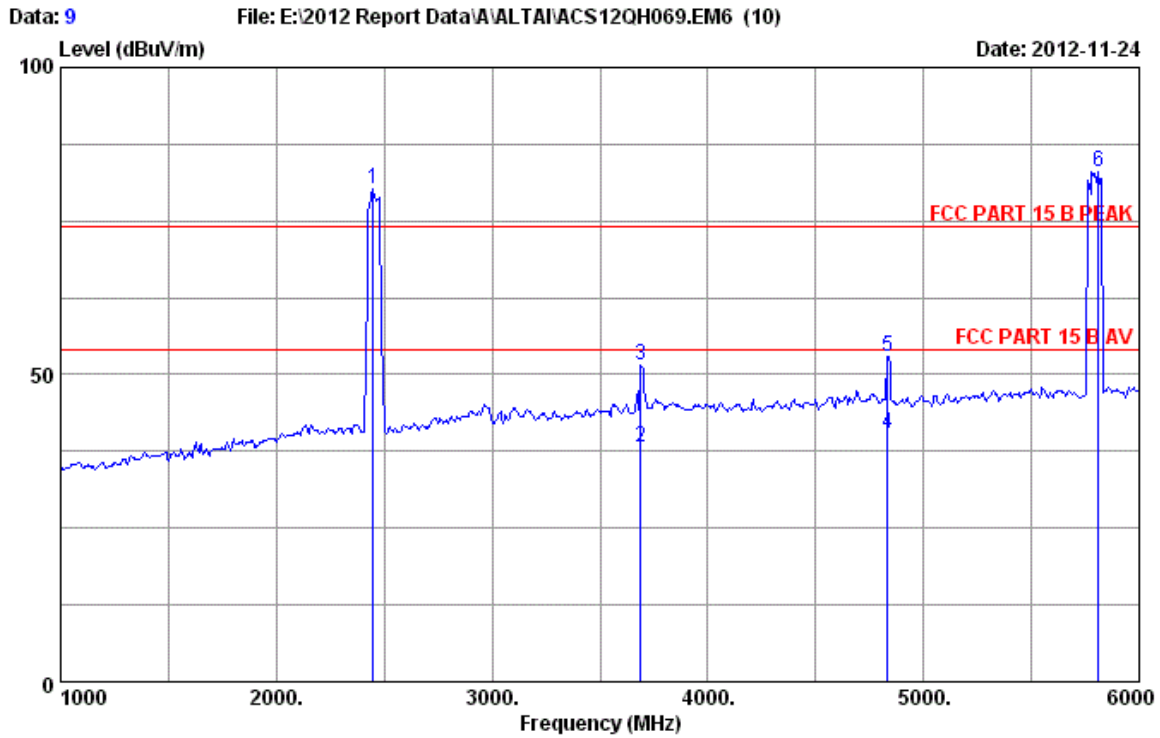

Site no. : 3m Chamber Data no. : 9
 Dis. / Ant. : 3m 2012 3115 9510-4580 Ant. pol. : HORIZONTAL
 Limit : FCC PART 15 B PEAK
 Env. / Ins. : 24°C/56% Engineer : Leo-Li
 EUT : A8-Ein Super WiFi Base Station
 Power Rating : DC 56V From Adapter Input AC 120V/60Hz
 Test Mode : Running
 M/N:WA8011N

No.	Freq. (MHz)	Ant. Factor (dB/m)	Cable Loss (dB)	AMP factor (dB)	Reading (dBuV)	Emission Level (dBuV/m)	Limits (dBuV/m)	Margin (dB)	Remark
1	2450.000	27.08	2.60	35.18	85.64	80.14	74.00	-6.14	Peak
2	3690.000	30.97	3.07	34.55	38.77	38.26	54.00	15.74	Average
3	3690.000	30.97	3.07	34.55	52.12	51.61	74.00	22.39	Peak
4	4835.000	32.54	3.66	34.32	38.49	40.37	54.00	13.63	Average
5	4835.000	32.54	3.66	34.32	51.11	52.99	74.00	21.01	Peak
6	5810.000	33.85	4.03	34.22	79.36	83.02	74.00	-9.02	Peak

Remarks: 1. Emission Level= Antenna Factor + Cable Loss + Reading - Amp Factor

2. The emission levels that are 20dB below the official limit are not reported.

3. 2450MHz and 5810 is the Signal from fundament Frequency. No need to comply with the limit

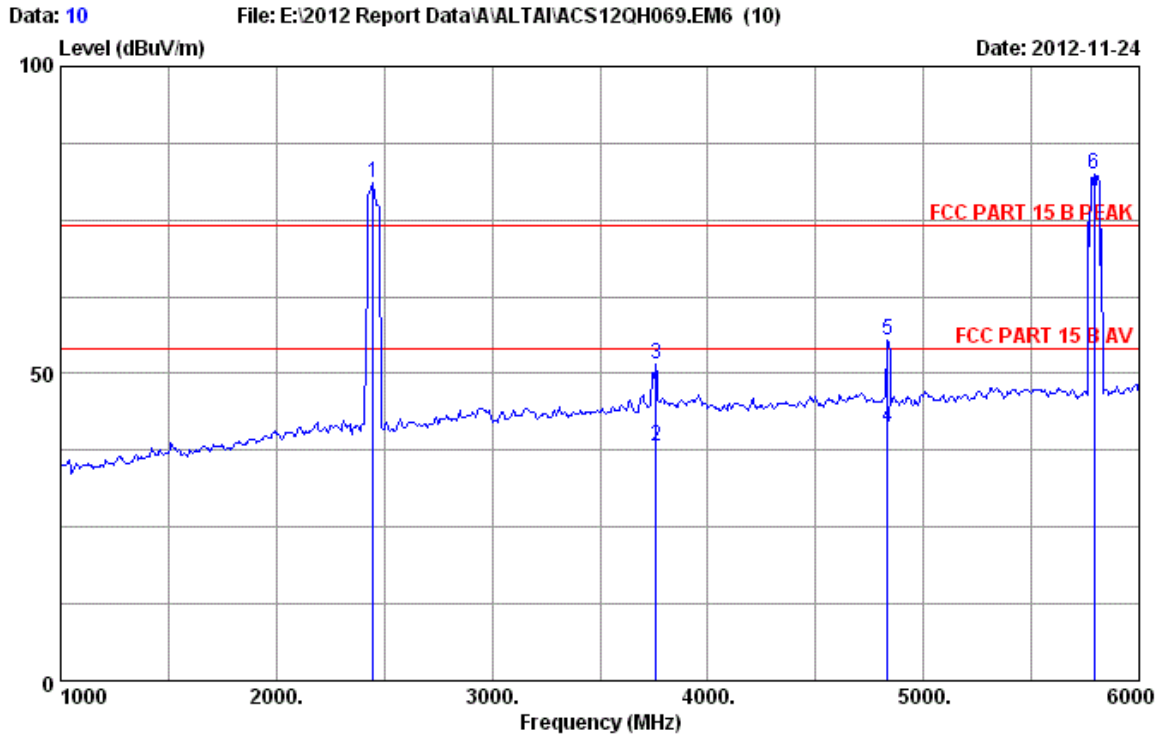

Site no. : 3m Chamber Data no. : 10
 Dis. / Ant. : 3m 2012 3115 9510-4580 Ant. pol. : VERTICAL
 Limit : FCC PART 15 B PEAK
 Env. / Ins. : 24°C/56% Engineer : Leo-Li
 EUT : A8-Ein Super WiFi Base Station
 Power Rating : DC 56V From Adapter Input AC 120V/60Hz
 Test Mode : Running
 M/N:WA8011N

No.	Freq. (MHz)	Ant. Factor (dB/m)	Cable Loss (dB)	AMP factor (dB)	Reading (dBUV)	Emission Level (dBUV/m)	Limits (dBUV/m)	Margin (dB)	Remark
1	2450.000	27.08	2.60	35.18	86.63	81.13	74.00	-7.13	Peak
2	3760.000	31.18	3.09	34.53	38.53	38.27	54.00	15.73	Average
3	3760.000	31.18	3.09	34.53	51.69	51.43	74.00	22.57	Peak
4	4835.000	32.54	3.66	34.32	39.31	41.19	54.00	12.81	Average
5	4835.000	32.54	3.66	34.32	53.50	55.38	74.00	18.62	Peak
6	5790.000	33.83	4.02	34.22	78.74	82.37	74.00	-8.37	Peak

Remarks: 1. Emission Level= Antenna Factor + Cable Loss + Reading -Amp Factor
 2. The emission levels that are 20dB below the official limit are not reported.
 3. 2450MHz and 5790 is the Signal from fundament Frequency. No need to comply with the limit



5. DEVIATION TO TEST SPECIFICATIONS

[NONE]

6. PHOTOGRAPH

6.1.Photos of Power Line Conducted Emission Test



6.2.Photos of Radiated Emission Test

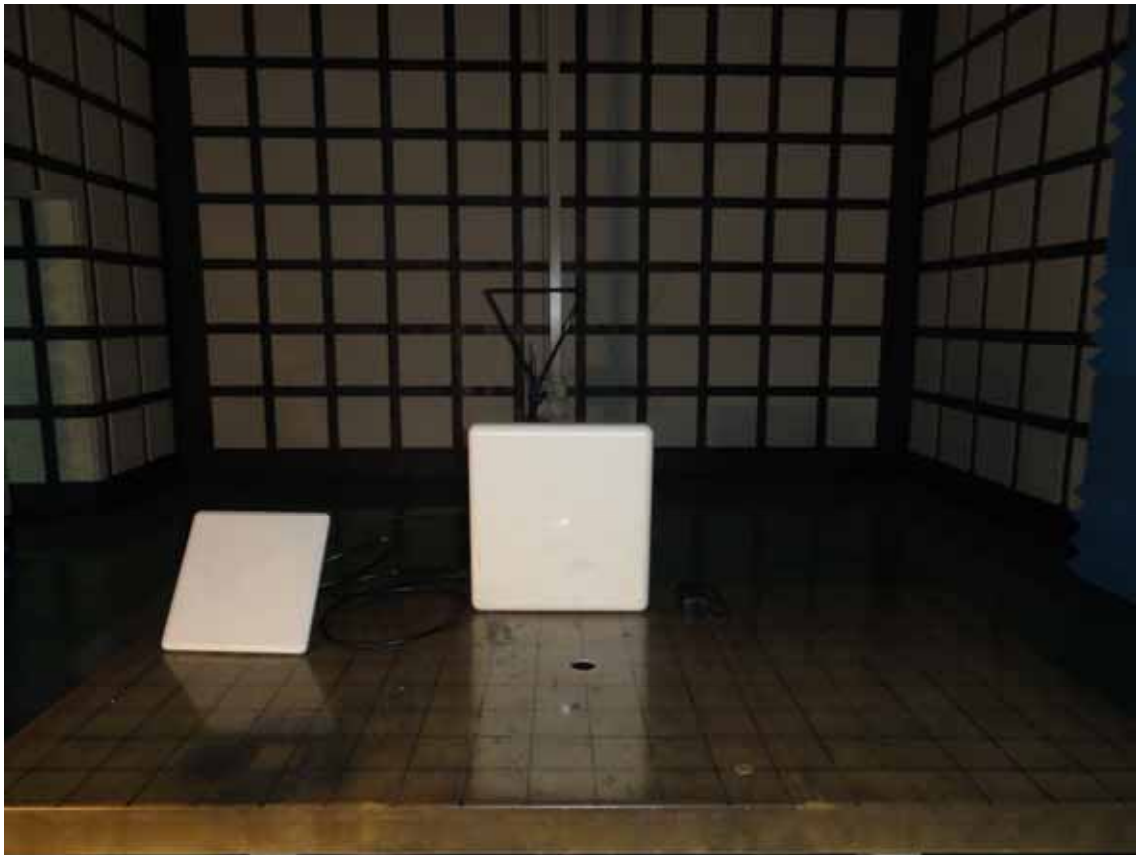
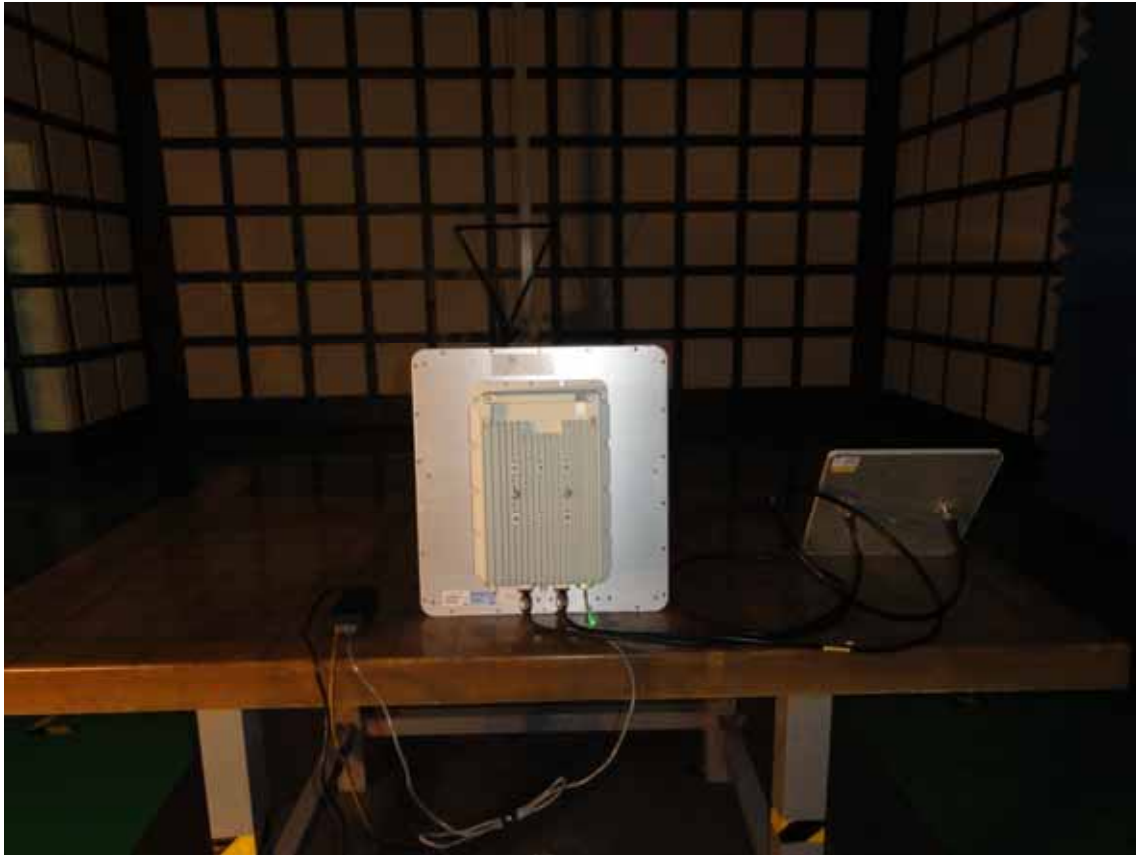

(Above 1000MHz)



a

7. PHOTOS OF THE EUT

Figure 1
General Appearance of the EUT



Figure 2
General Appearance of the EUT



Figure 3
General Appearance of the EUT



Figure 4
General Appearance of the EUT



Figure 5
General Appearance of the EUT



Figure 6
Inside of the EUT



Figure 7
Inside of the EUT



Figure 8
Inside of the EUT

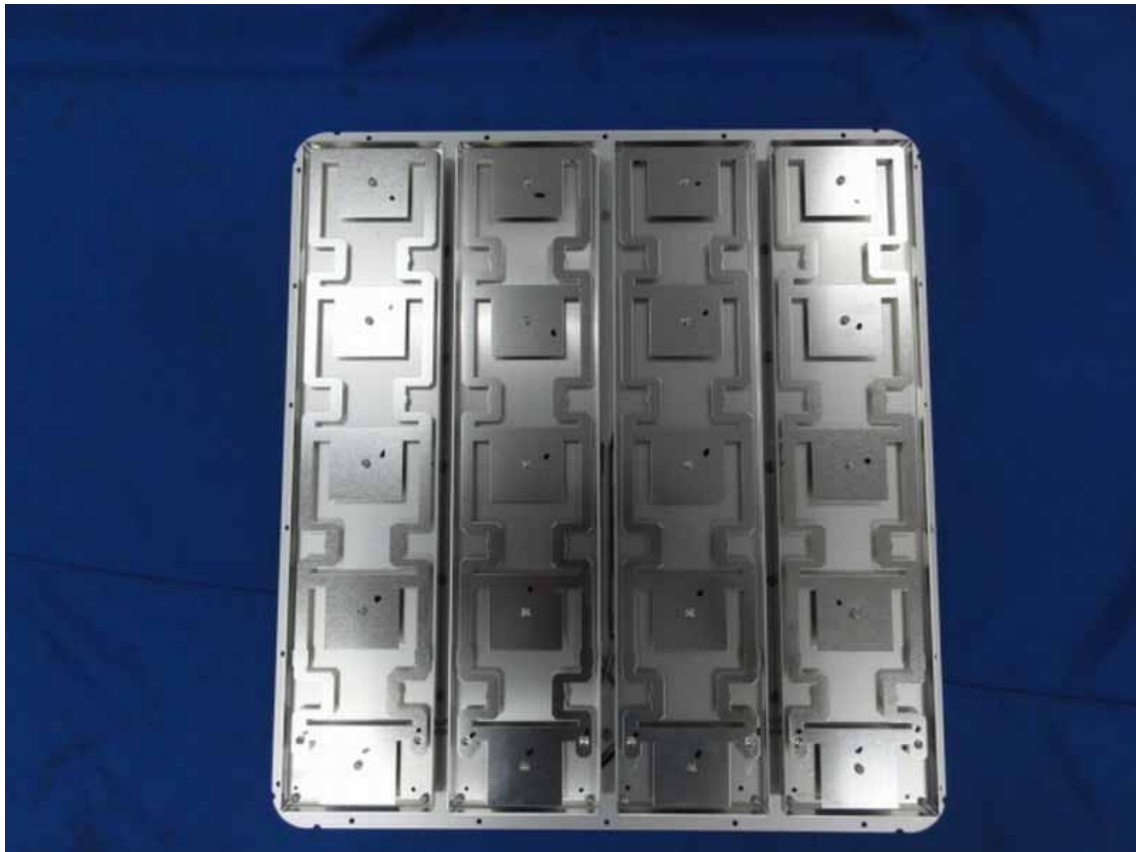

Figure 9
Inside of the EUT



Figure 10
Component Side of the PCB

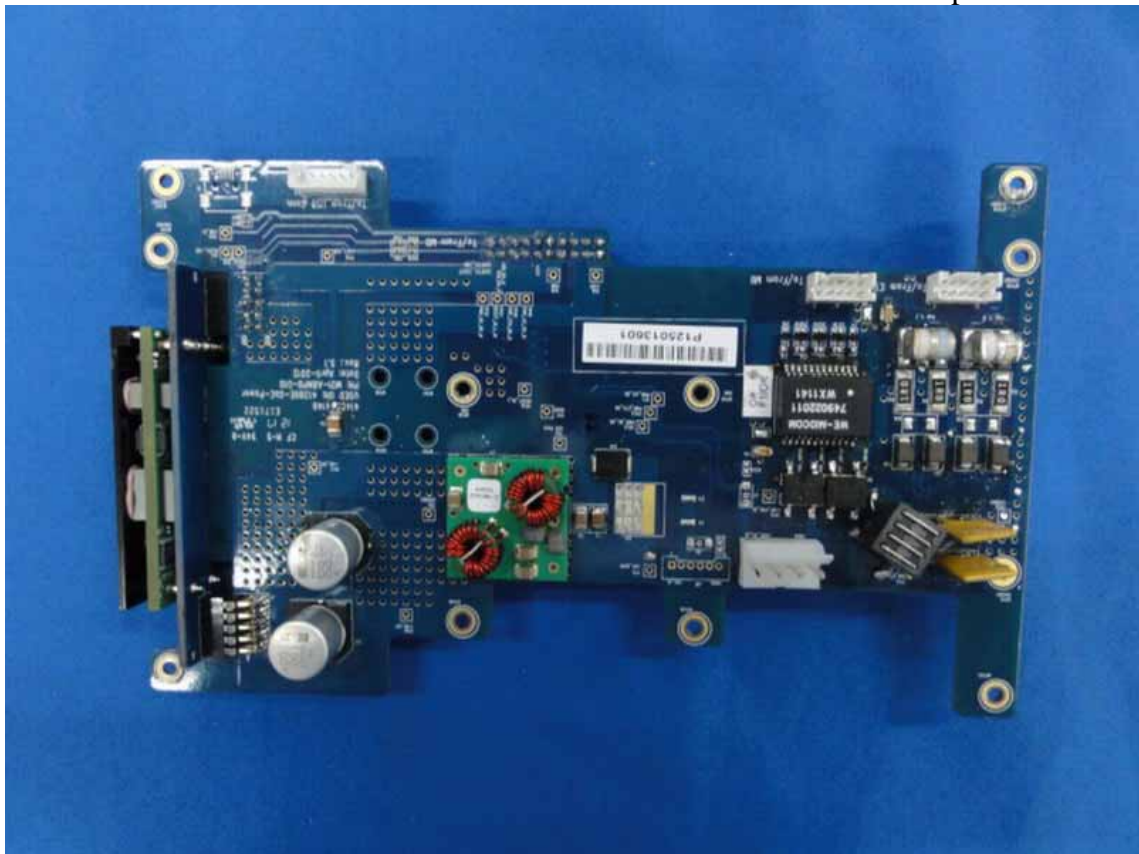

Figure 11
Component Side of the PCB

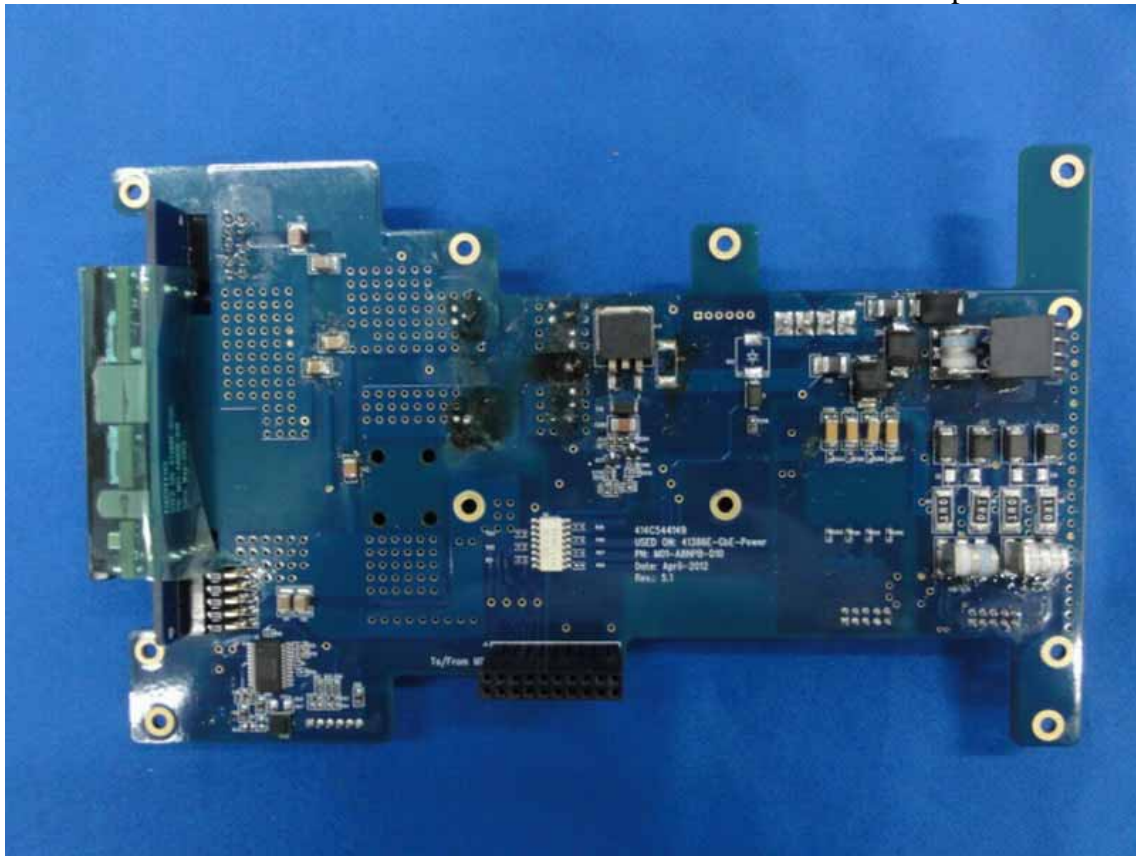

Figure 12
Component Side of the PCB

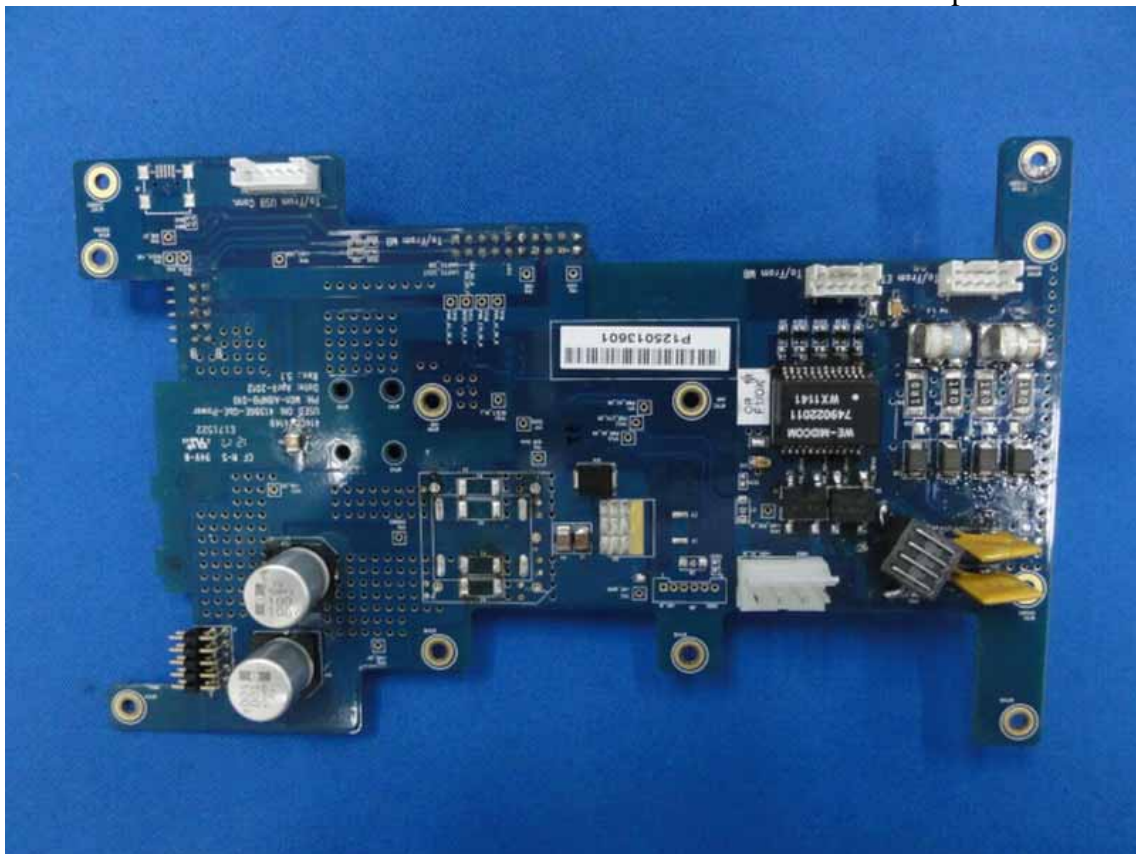

Figure 13
Component Side of the PCB

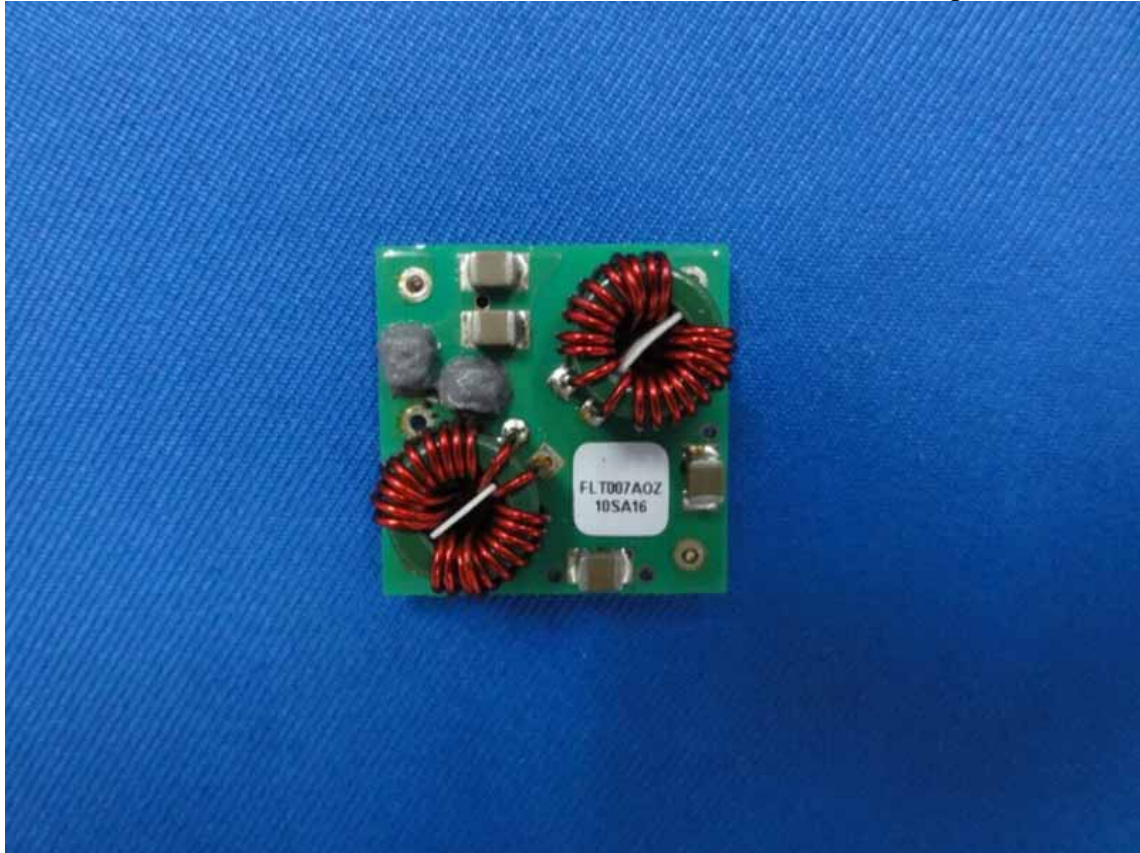

Figure 14
Component Side of the PCB

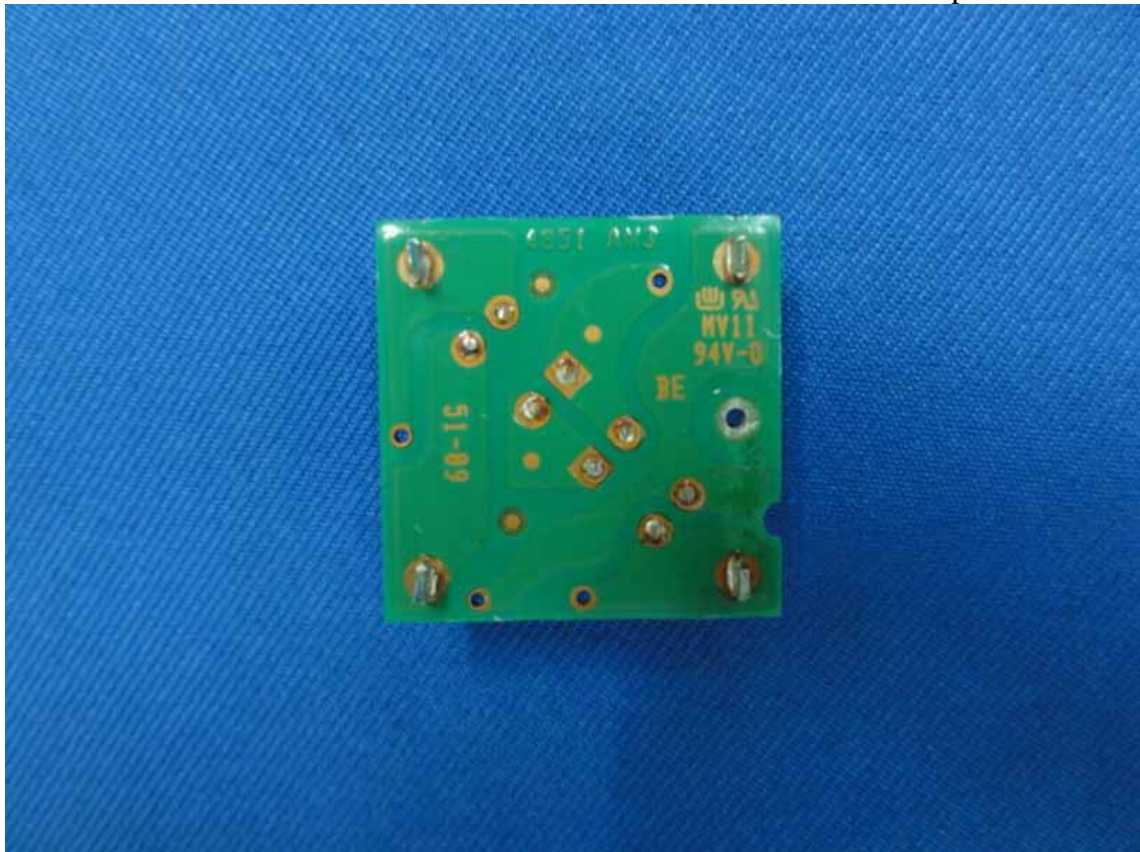

Figure 15
Component Side of the PCB



Figure 16
Component Side of the PCB

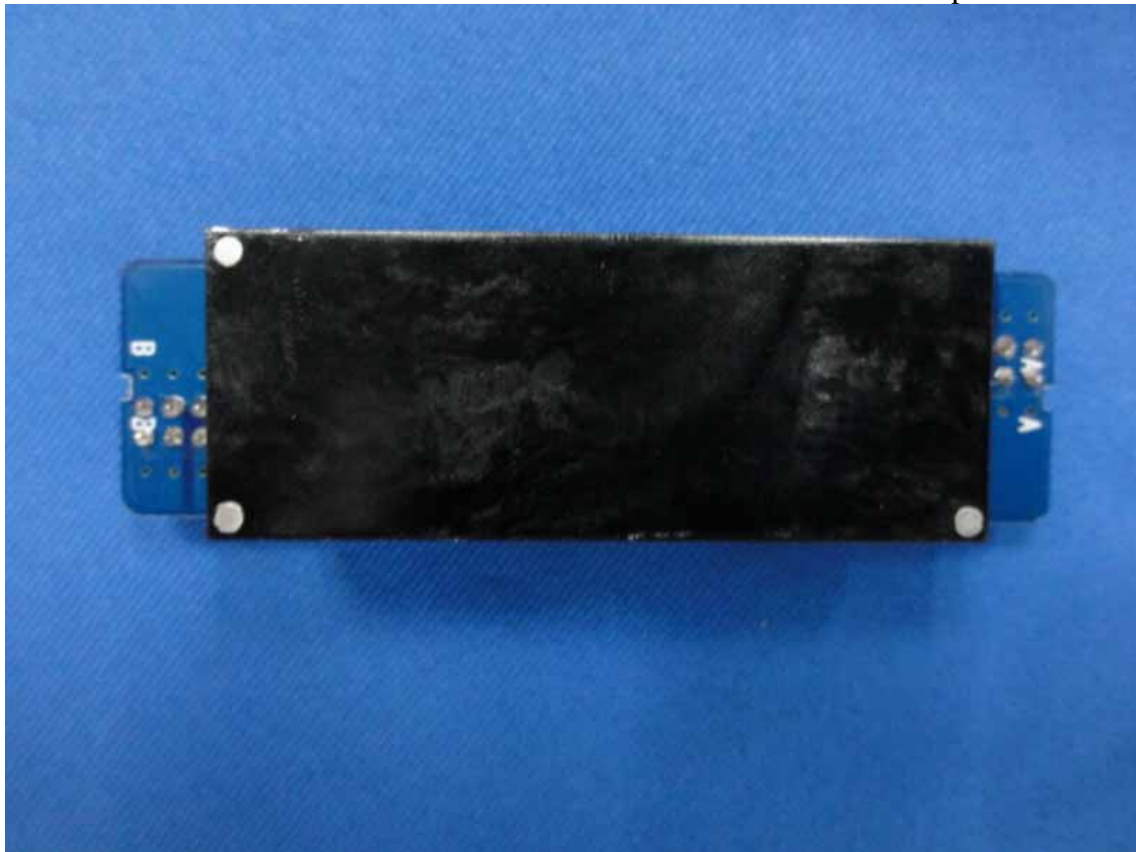

Figure 17
Component Side of the PCB



Figure 18
Component Side of the PCB



Figure 19
Component Side of the PCB



Figure 20
Component Side of the PCB

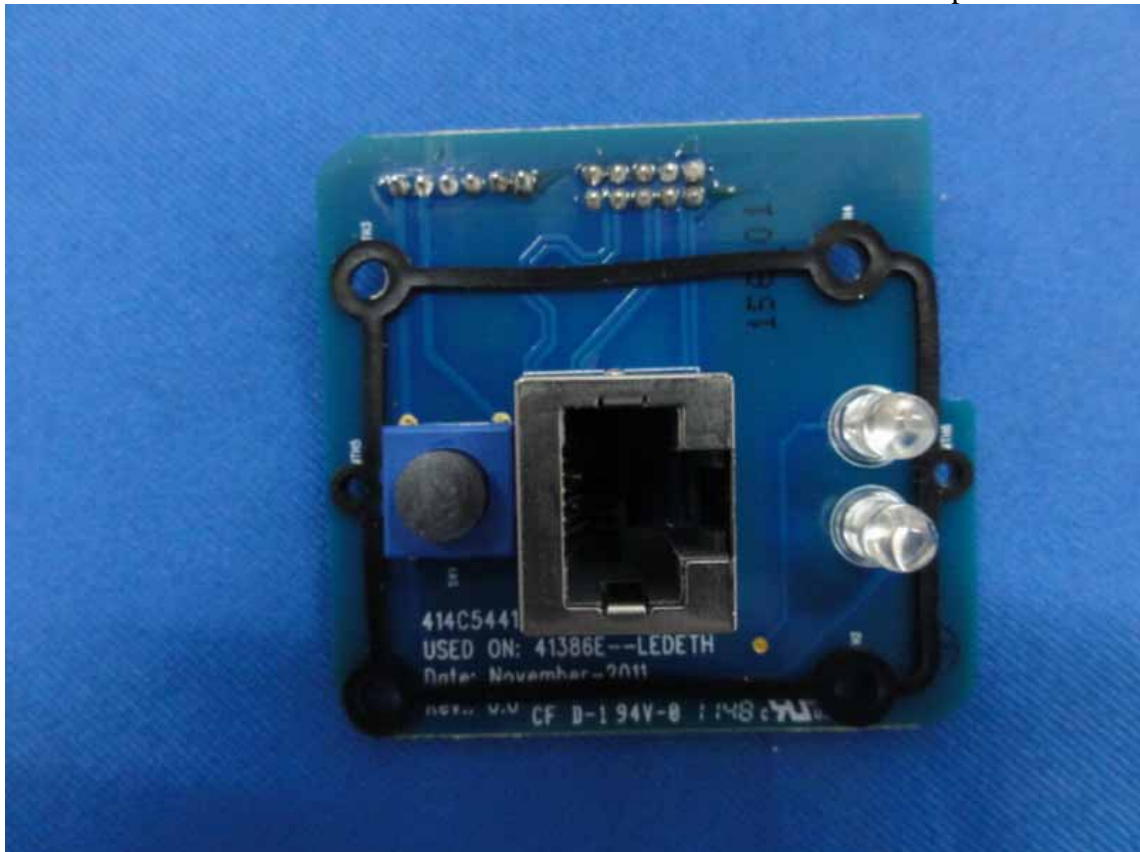

Figure 21
Component Side of the PCB



Figure 22
Component Side of the PCB

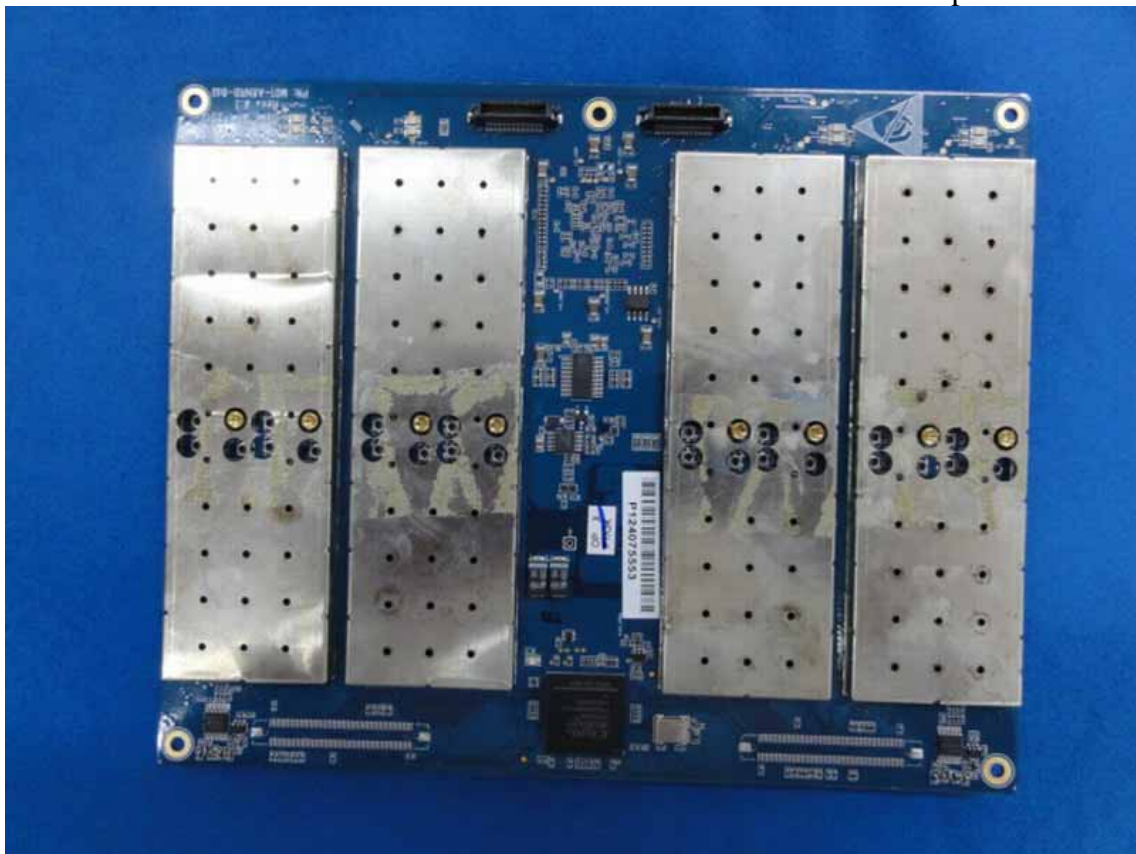

Figure 23
Component Side of the PCB

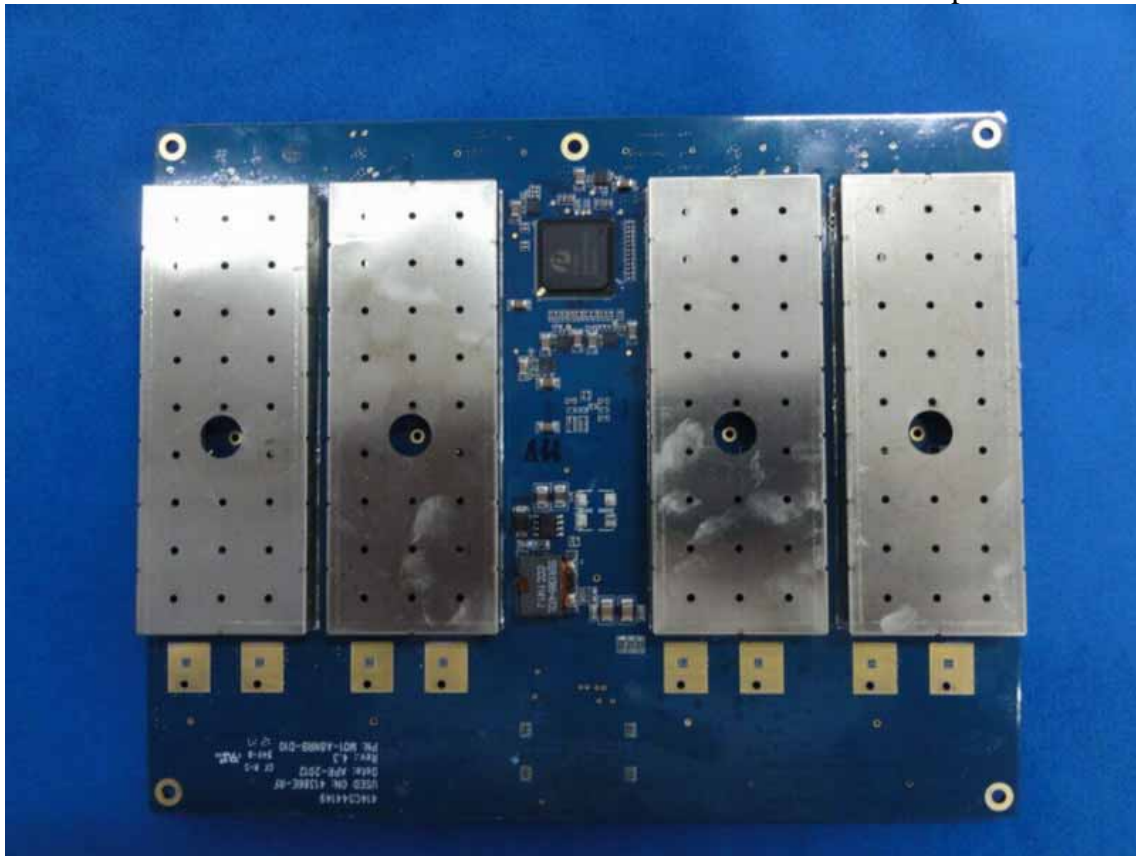

Figure 24
Component Side of the PCB



Figure 25
Component Side of the PCB



Figure 26
Component Side of the PCB



Figure 27
Component Side of the PCB



Figure 28
Component Side of the PCB

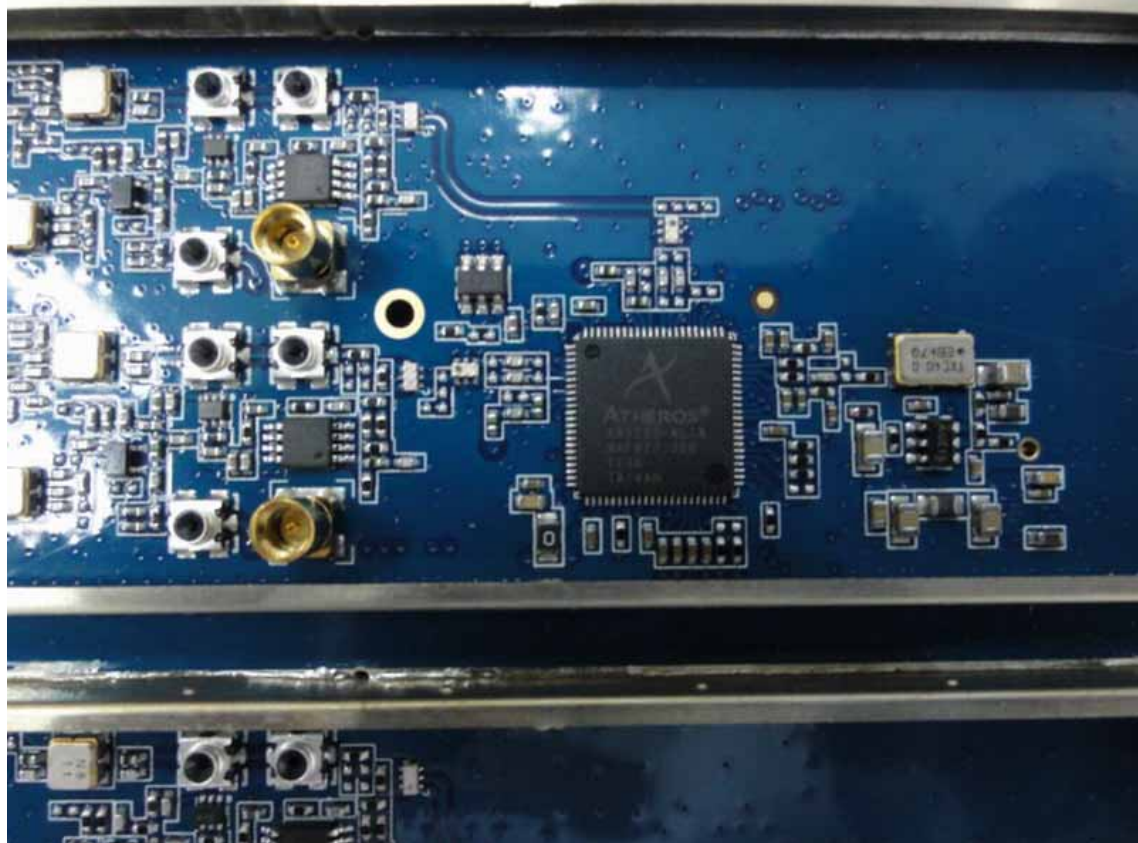

Figure 29
Component Side of the PCB

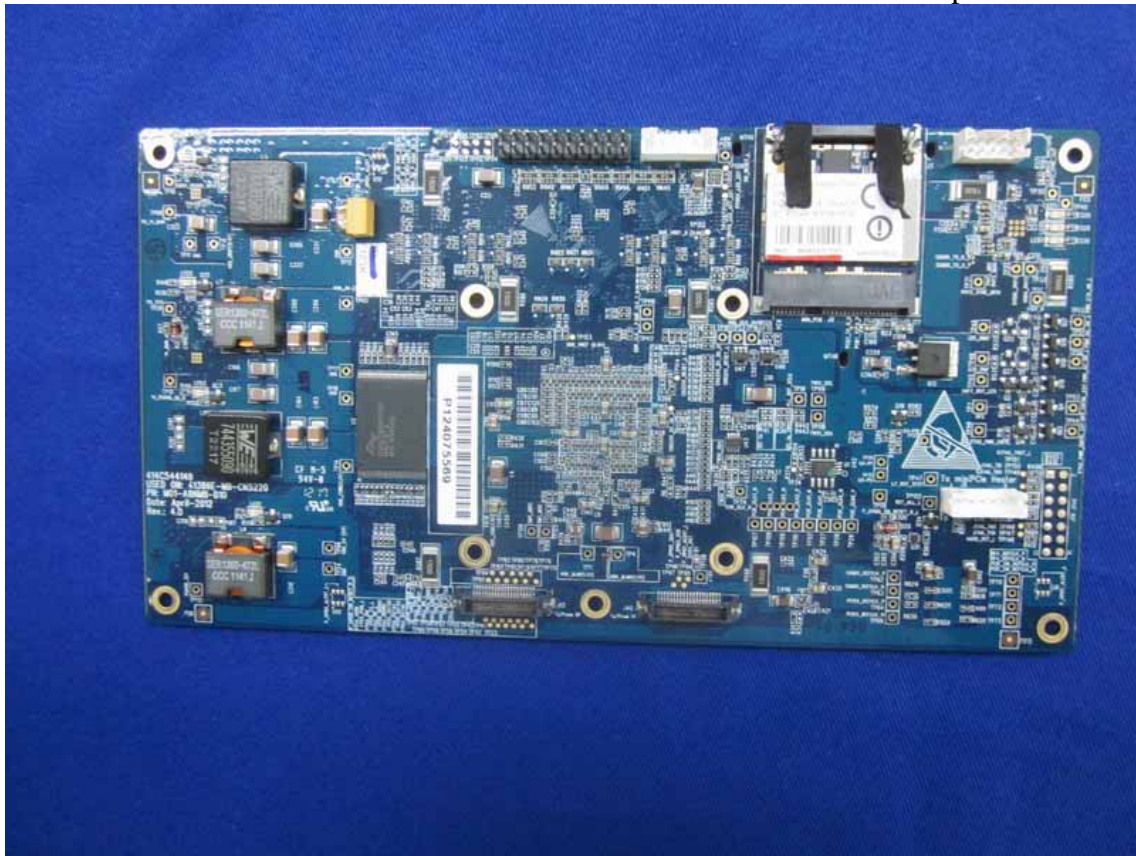

Figure 30
Component Side of the PCB

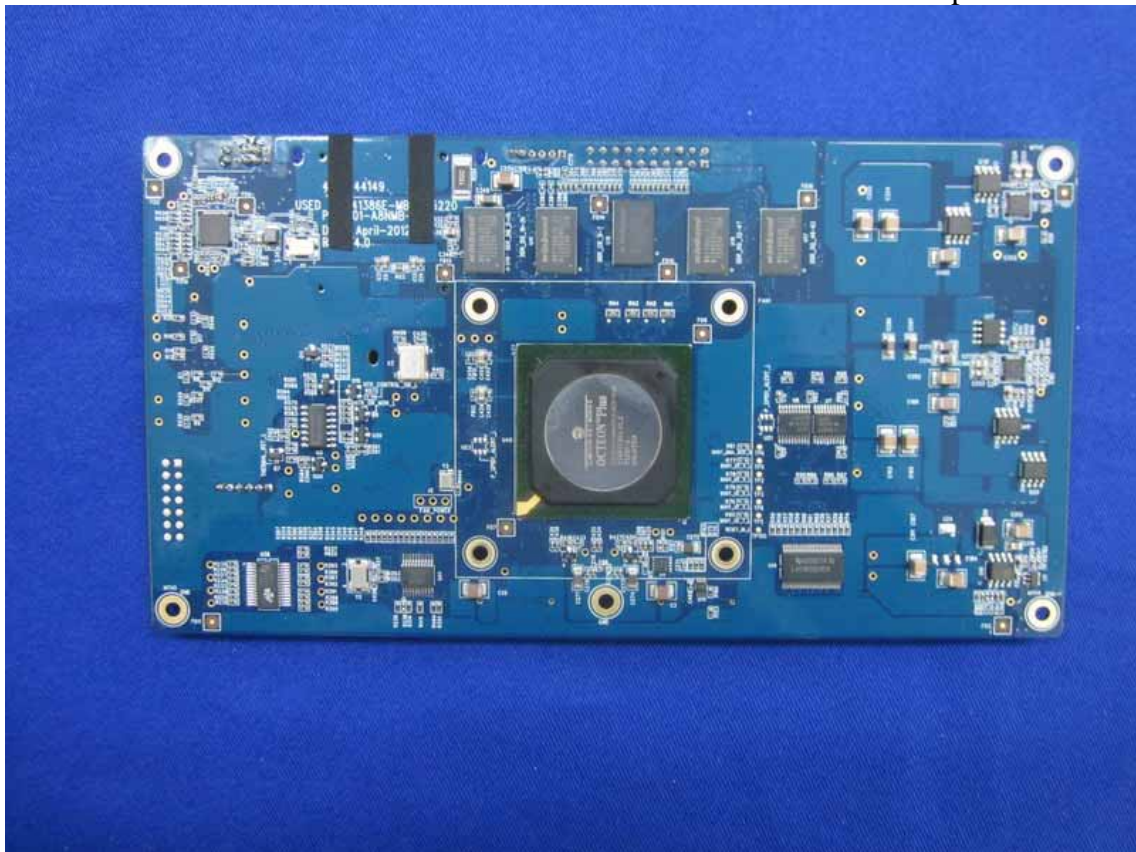

Figure 31
Component Side of the PCB

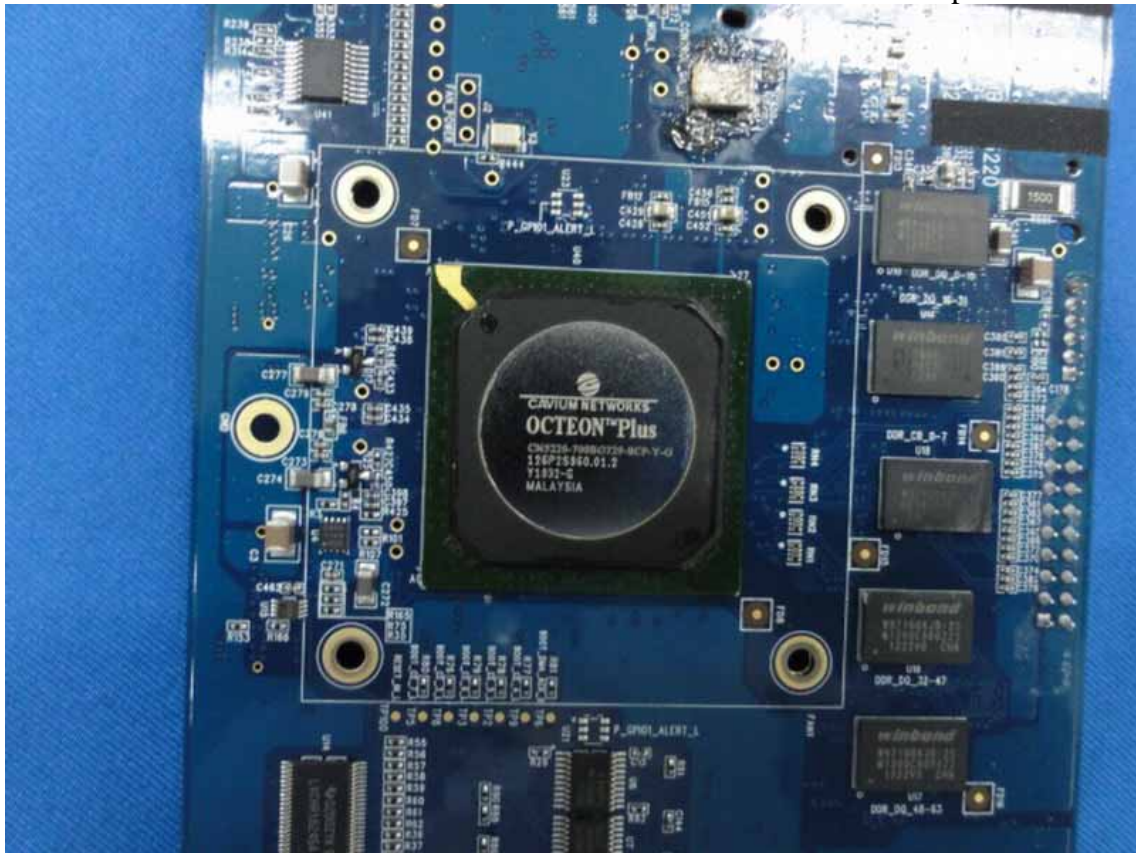

Figure 32
Component Side of the PCB



Figure 33
Component Side of the PCB



Figure 34
Component Side of the PCB

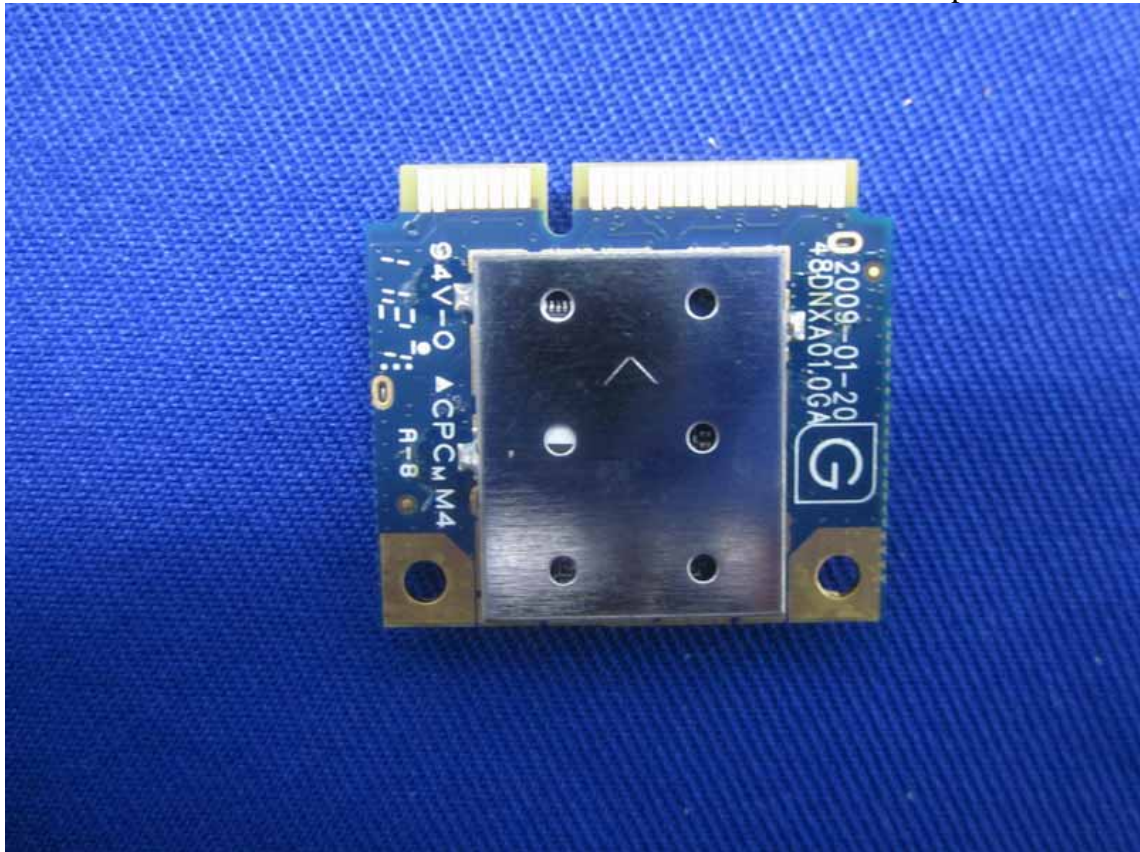

Figure 35
Component Side of the PCB



Figure 36
Component Side of the PCB

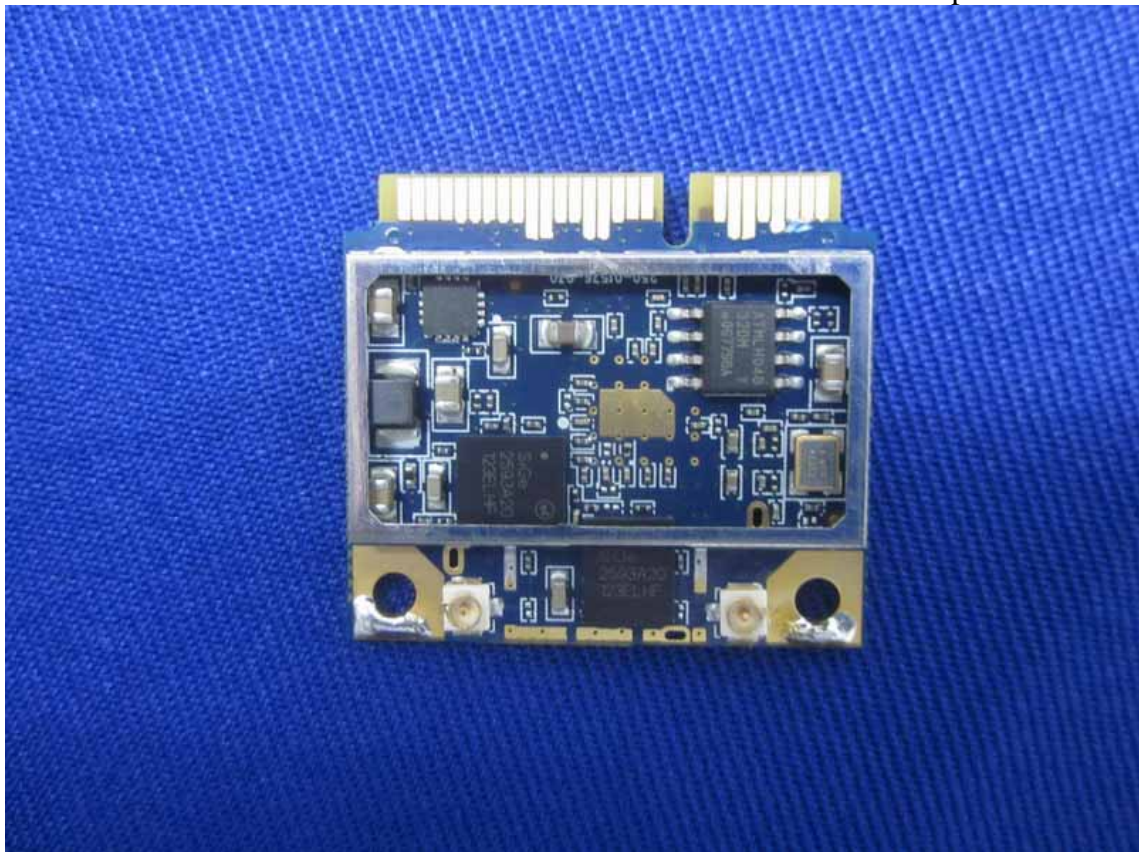

Figure 37
AC Adapter



Figure 38
AC Adapter



Figure 39
AC Adapter



Figure 40
AC Adapter

