

FCC PART 15E TEST REPORT FOR CERTIFICATION
On Behalf of

Altai Technologies Limited

Altai A3w Indoor Dual-band 3X3 802.11ac WiFi AP

Model Number: WA3311NAC-W

FCC ID: UCC-WA3311NAC-W

Prepared for : Altai Technologies Limited

Units 209, 2/F, Lakeside 2.10 Science Park West Avenue,
Hong Kong Science Park, Shatin, Hong Kong, China

Prepared By : Audix Technology (Shenzhen) Co., Ltd.

No. 6, Ke Feng Rd., 52 Block,
Shenzhen Science & Industrial Park,
Nantou, Shenzhen, Guangdong, China

Tel: (0755) 26639496

Report Number : ACS-F16050

Date of Test : Jan.17~Feb.05, 2016

Date of Report : Mar.22, 2016

TABLE OF CONTENTS

<u>Description</u>	<u>Page</u>
1. SUMMARY OF STANDARDS AND RESULTS	1-1
1.1. Description of Standards and Results	1-1
2. GENERAL INFORMATION	2-1
2.1. Description of Device (EUT)	2-1
2.2. Test Information	2-2
2.1. Tested Supporting System Details	2-3
2.2. Block diagram of connection between the EUT and simulators	2-3
2.3. Test Facility	2-4
2.4. Measurement Uncertainty (95% confidence levels, k=2)	2-4
3. POWER LINE CONDUCTED EMISSION TEST	3-1
3.1. Test Equipments	3-1
3.2. Block Diagram of Test Setup	3-1
3.3. Power Line Conducted Emission Test Limits	3-1
3.4. Configuration of EUT on Test	3-2
3.5. Operating Condition of EUT	3-2
3.6. Test Procedure	3-2
3.7. Power Line Conducted Emission Test Results	3-2
4. RADIATED EMISSION TEST	4-1
4.1. Test Equipment	4-1
4.2. Block Diagram of Test Setup	4-2
4.3. Radiated Emission Limit	4-3
4.4. EUT Configuration on Test	4-3
4.5. Operating Condition of EUT	4-4
4.6. Test Procedure	4-4
4.7. Radiated Emission Test Results	4-5
5. BAND EDGE COMPLIANCE TEST	5-1
5.1. Test Equipment	5-1
5.2. Limit	5-1
5.3. Test Produce	5-1
5.4. Test Results	5-1
6. 6dB&26dB Bandwidth Test	6-1
6.1. Test Equipment	6-1
6.2. Limit	6-1
6.3. Test Procedure	6-1
6.4. Test Results	6-1
7. OUTPUT POWER TEST	7-1
7.1. Test Equipment	7-1
7.2. Limit	7-1
7.3. Test Procedure	7-1
7.4. Test Results	7-2
8. SPECTRAL DENSITY TEST	8-1
8.1. Test Equipment	8-1
8.2. Limit	8-1
8.3. Test Procedure	8-1
8.4. Test Results	8-2
9. FREQUENCY STABILITY MEASUREMENT	9-1
9.1. Test Equipment	9-1
9.2. Limit	9-1
9.3. Test Procedure	9-1
9.4. Test Result	9-1

10.	MPE ESTIMATION	10-1
	10.1. Limit for General Population/ Uncontrolled Exposures	10-1
	10.2. Estimation Result.....	10-1
11.	ANTENNA REQUIREMENT	11-1
	11.1. Standard Applicable	11-1
	11.2. Antenna Connected Construction.....	11-1
12.	DEVIATION TO TEST SPECIFICATIONS	12-1
13.	PHOTOGRAPH OF TEST.....	13-1
	13.1. Photos of Power Line Conducted Emission Test	13-1
	13.2. Photos of Radiated Emission Test	13-2
14.	PHOTOS OF THE EUT	14-1

TEST REPORT CERTIFICATION

Applicant : Altai Technologies Limited
 Manufacturer : Altai Technologies Limited
 EUT Description : Altai A3w Indoor Dual-band 3X3 802.11ac WiFi AP
 FCC ID : UCC-WA3311NAC-W
 (A) Model No. : WA3311NAC-W
 (B) Power Supply : DC 56V
 (C) Test Voltage : DC 56V From POE Input AC 120V/60Hz

Tested for comply with:
 FCC CFR 47 Part 15 Subpart E: 2014

Test procedure used:
 ANSI C63.10: 2013
 KDB789033D01

The device described above is tested by AUDIX TECHNOLOGY (SHENZHEN) CO., LTD. to confirm comply with all the FCC Part 15 Subpart E requirements. The test results are contained in this test report and AUDIX TECHNOLOGY (SHENZHEN) CO., LTD. is assumed full responsibility for the accuracy and completeness of these tests. Also, this report shows that the Equipment Under Test (EUT) is to be technically compliant with the FCC and IC requirements. This report contains data that are not covered by the NVLAP accreditation.

This Report is made under FCC Part 2.1075. No modifications were required during testing to bring this product into compliance.

This report applies to above tested sample only. This report shall not be reproduced in part without written approval of AUDIX TECHNOLOGY (SHENZHEN) CO., LTD.

The report must not be used by the client to claim product certification, approval, or endorsement by NVLAP, NIST, or any agency of the federal government.

Date of Test : Jan.17~Feb.05, 2016 Report of date: Mar.22, 2016

Prepared by : Kayli He Reviewed by : Sunny Lu
 Kayli He / Assistant Sunny Lu / Assistant Manager

信華科技(深圳)有限公司
 Audix Technology (Shenzhen) Co., Ltd.
 EMC 部門報告專用章
 Stamp only for EMC Dept. Report
 Signature: David Jin

Approved & Authorized Signer : David Jin
 David Jin / Manager

1. SUMMARY OF STANDARDS AND RESULTS

1.1. Description of Standards and Results

The EUT have been tested according to the applicable standards as referenced below.

EMISSION		
Description of Test Item	Standard	Results
Power Line Conducted Emission	FCC Part 15: 15.207	PASS
Radiated Emission	FCC Part 15: 15.209	PASS
Band Edge Compliance	FCC Part 15: 15.407	PASS
6dB&26Bandwidth Test	FCC Part 15: 15.407(a)	PASS
Output Power Test	FCC Part 15: 15.407(a)	PASS
Power Spectral Density Test	FCC Part 15: 15.407(a)	PASS
Frequency Stability	FCC Part 15: 15.407(g)	PASS
Antenna requirement	FCC Part 15: 15.203	PASS

N/A is an abbreviation for Not Applicable.

2. GENERAL INFORMATION

2.1. Description of Device (EUT)

Product Name	: Altai A3w Indoor Dual-band 3X3 802.11ac WiFi AP
Model Number	: WA3311NAC-W
FCC ID	: UCC-WA3311NAC-W
Operation Frequency	: IEEE 802.11a: 5745MHz—5825MHz IEEE 802.11b: 2412MHz—2462MHz IEEE 802.11g: 2412MHz—2462MHz IEEE 802.11n HT20: 2412MHz—2462MHz; 5745MHz—5825MHz IEEE 802.11n HT40: 2422MHz—2452MHz; 5755MHz—5795MHz IEEE 802.11ac VHT20: 5745MHz—5825MHz IEEE 802.11ac VHT40: 5755MHz—5795MHz IEEE 802.11ac VHT80: 5775MHz
Modulation Technology	: IEEE 802.11b: DSSS(CCK,DQPSK,DBPSK) IEEE 802.11a/g: OFDM(64QAM, 16QAM, QPSK, BPSK) IEEE 802.11ac VHT20, VHT40, VHT80: OFDM(16QAM, 64QAM, 256QAM, QPSK, BPSK) IEEE 802.11n HT20, HT40: OFDM (64QAM, 16QAM,QPSK,BPSK)
Antenna Assembly Gain	: Built-in Antenna (3T3R), 10dBi gain
Applicant	: Altai Technologies Limited Units 209, 2/F, Lakeside 2.10 Science Park West Avenue, Hong Kong Science Park, Shatin, Hong Kong, China
Manufacturer	: Altai Technologies Limited Units 209, 2/F, Lakeside 2.10 Science Park West Avenue, Hong Kong Science Park, Shatin, Hong Kong, China
POE	: Manufacturer: FSGREAT;M/N: GRT-560110A INPUT:AC 100-240V 50/60Hz OUTPUT:56V 1100mA
Date of Test	: Jan.17~Feb.05, 2016
Date of Receipt	: Jan.13, 2016
Sample Type	: Prototype production

2.2. Test Information

A special test software was used to control EUT work in Continuous TX mode (nearly 100% duty cycle), and select test channel, wireless mode and data rate.

Tested mode, channel, and data rate information			
Mode	data rate (Mbps)(see Note)	Channel	Frequency (MHz)
IEEE 802.11a	6	Low :CH149	5745
	6	Middle: CH157	5785
	6	High: CH165	5825
IEEE 802.11nHT20	MCS0	Low :CH149	5745
	MCS0	Middle: CH157	5785
	MCS0	High: CH165	5825
IEEE 802.11nHT40	MCS0	Low :CH151	5755
	MCS0	High: CH159	5795
IEEE 802.11acVHT20	MCS0	Low :CH149	5745
	MCS0	Middle: CH157	5785
	MCS0	High: CH165	5825
IEEE 802.11acVHT40	MCS0	Low :CH151	5755
	MCS0	High: CH159	5795
IEEE 802.11acVHT80	MCS0	CH155	5775

Note: 1. According exploratory test, EUT will have maximum output power in those data rate, so those data rate were used for all test.

Note: 2. This is MIMO 3*3 device, test with three antenna transmit simultaneously and comply with KDB662911D01 V02r01.

2.1. Tested Supporting System Details

No.	Description	ACS No.	Manufacturer	Model	Serial Number
1	Notebook	N/A	DELL	PP09S	N/A
		Power Cord: Unshielded, Detachable, 1.8m Power Adapter: Manufacturer: DELL, M/N: LA65NS1-00 Cable: Unshielded, Detachable, 4.0m(Bond one ferrite core)			

2.2. Block diagram of connection between the EUT and simulators

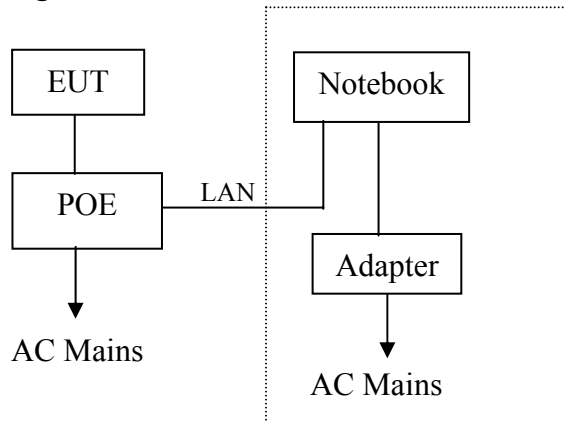

(EUT: Altai A3w Indoor Dual-band 3X3 802.11ac WiFi AP)

2.3. Test Facility

Site Description

Name of Firm	:	Audix Technology (Shenzhen) Co., Ltd. No. 6, Ke Feng Rd., 52 Block, Shenzhen Science & Industrial Park, Nantou, Shenzhen, Guangdong, China
3m Anechoic Chamber	:	Certificated by FCC, USA Registration Number: 90454 Valid Date: Dec.30, 2017
3m & 10m Anechoic Chamber	:	Certificated by FCC, USA Registration Number: 794232 Valid Date: Jul.12, 2016
EMC Lab.	:	Certificated by Industry Canada Registration Number: IC 5183A-1 Valid Date: May.14, 2017
	:	Certificated by DAkkS, Germany Registration No: D-PL-12151-01-00 Valid Date: Dec.15, 2016
	:	Accredited by NVLAP, USA NVLAP Code: 200372-0 Valid Date: Mar.31, 2016

2.4. Measurement Uncertainty (95% confidence levels, k=2)

Test Item	Uncertainty
Uncertainty for Conduction emission test in No. 1 Conduction	3.4dB (150KHz to 30MHz)
Uncertainty for Radiation Emission test in 3m chamber	2.6dB (30~200MHz, Polarization: H)
	2.6dB (30~200MHz, Polarization: V)
	3.0dB (200M~1GHz, Polarization: H)
	2.8dB (200M~1GHz, Polarization: V)
Uncertainty for Radiation Emission test in 3m chamber (1GHz-18GHz)	6.3dB (1~6GHz, Distance: 3m)
	5.7dB (6~18GHz, Distance: 3m)
Uncertainty for Radiated Spurious Emission test in RF chamber	3.6dB
Uncertainty for Conduction Spurious emission test	2.0dB
Uncertainty for Output power test	0.8dB
Uncertainty for Bandwidth test	83kHz
Uncertainty for DC power test	0.1%
Uncertainty for test site temperature and humidity	0.6°C
	3%

3. POWER LINE CONDUCTED EMISSION TEST

3.1. Test Equipments

Item	Equipment	Manufacturer	Model No.	Serial No.	Last Cal.	Cal. Interval
1.	1# Shielding Room	AUDIX	N/A	N/A	Apr.17,15	1 Year
2.	Test Receiver	Rohde & Schwarz	ESCI	100842	Apr.28,15	1 Year
3.	L.I.S.N.#1	Rohde & Schwarz	ESH2-Z5	100429	Oct.18,15	1 Year
4.	L.I.S.N.#2	Kyoritsu	K NW-403D	8-1750-2	Apr.28,15	1 Year
5.	Terminator	Hubersuhner	50Ω	No.1	Apr.28,15	1 Year
6.	Terminator	Hubersuhner	50Ω	No.2	Apr.28,15	1 Year
7.	RF Cable	MIYAZAKI	3D-2W	No.1	Apr.28,15	1Year
8.	Coaxial Switch	Anritsu	MP59B	6200766906	Apr.28,15	1 Year
9.	Test Software	AUDIX	e3	6.100913a	N/A	N/A

3.2. Block Diagram of Test Setup

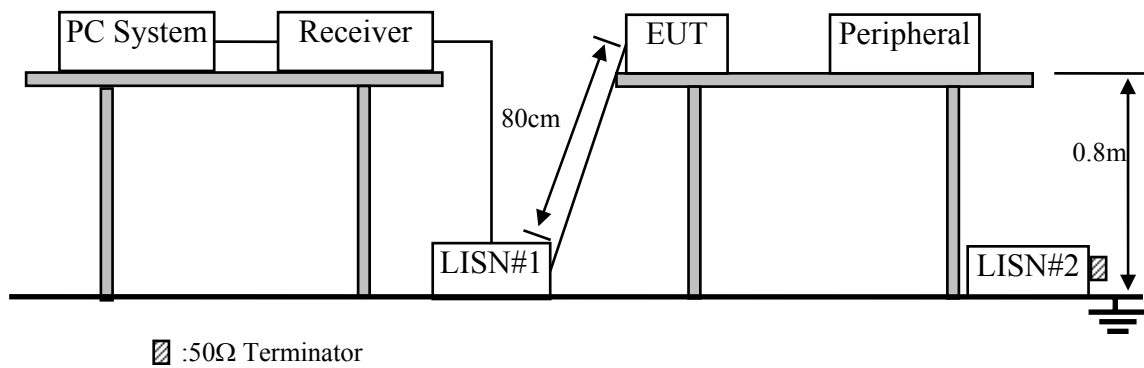

3.3. Power Line Conducted Emission Test Limits

Frequency	Maximum RF Line Voltage	
	Quasi-Peak Level dB(μV)	Average Level dB(μV)
150kHz ~ 500kHz	66 ~ 56*	56 ~ 46*
500kHz ~ 5MHz	56	46
5MHz ~ 30MHz	60	50

Notes: 1. * Decreasing linearly with logarithm of frequency.

2. The lower limit shall apply at the transition frequencies.

3.4. Configuration of EUT on Test

The following equipment are installed on Power Line Conducted Emission Test to meet the commission requirement and operating regulations in a manner which tends to maximize its emission characteristics in a normal application.

3.4.1. Altai A3w Indoor Dual-band 3X3 802.11ac WiFi AP (EUT)

Model Number : WA3311NAC-W
Serial Number : N/A

3.4.2. Support Equipment: As Tested Supporting System Details, in Section 2.2.

3.5. Operating Condition of EUT

3.5.1. Setup the EUT and simulator as shown as Section 3.2.

3.5.2. Turn on the power of all equipments.

3.5.3. PC run test software to control EUT work in Tx mode.

3.6. Test Procedure

The EUT was placed on a non-metallic table, 80cm above the ground plane. The EUT Power Via PC connected to the power mains through a line impedance stabilization network (L.I.S.N. 1#). This provides a 50 ohm coupling impedance for the EUT (Please refer the block diagram of the test setup and photographs). The AC line are checked to find out the maximum conducted emission. In order to find the maximum emission levels, the relative positions of equipment and all of the interface cables shall be changed according to ANSI C63.10: 2013 on Conducted Emission Test.

The bandwidth of test receiver (R & S ESCI) is set at 9kHz.

The frequency range from 150kHz to 30MHz is checked.

3.7. Power Line Conducted Emission Test Results

PASS. (All emissions not reported below are too low against the prescribed limits.)

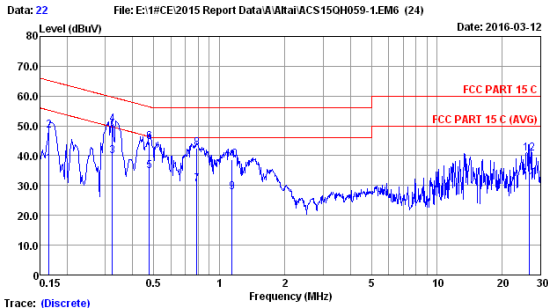

Trace: (Discrete)
 Site no :1# Conduction Data No :22
 Dis./Lisn :2015 ESH2-25 LINE
 Limit :FCC PART 15 C
 Env./Ins. :23.5°C/48% Engineer :Leo-Li
 EUT :Altai A3w Indoor Dual-band 3x3 802.11ac WiFi AP
 Power Rating :DC 56V From POE Input AC 120V/60Hz
 Test Mode :Tx Mode
 N/N:WA3311NAC-W

No	Freq (MHz)	LISN Factor (dB)	Cable Loss (dB)	Reading (dBuV)	Emission Level (dBuV)	Limits (dBuV)	Margin (dB)	Remark
1	0.165	0.12	0.05	36.90	37.07	55.21	18.14	Average
2	0.165	0.12	0.05	48.20	48.37	65.21	16.84	QP
3	0.322	0.13	0.06	39.60	39.79	49.66	9.87	Average
4	0.322	0.13	0.06	50.20	50.39	59.66	9.27	QP
5	0.478	0.14	0.06	34.50	34.70	46.37	11.67	Average
6	0.478	0.14	0.06	44.50	44.70	56.37	11.67	QP
7	0.787	0.15	0.07	30.20	30.42	46.00	15.58	Average
8	0.787	0.15	0.07	42.30	42.52	56.00	13.48	QP
9	1.147	0.17	0.08	27.60	27.85	46.00	18.15	Average
10	1.147	0.17	0.08	38.50	38.75	56.00	17.25	QP
11	26.558	1.13	0.37	29.40	30.90	50.00	19.10	Average
12	26.558	1.13	0.37	39.30	40.80	60.00	19.20	QP

Remarks: 1.Emission Level=LISN Factor+Cable Loss+Reading.
 2.If the average limit is met when using a quasi-peak detector, the EUT shall be deemed to meet both limits and measurement with average detector is unnecessary.

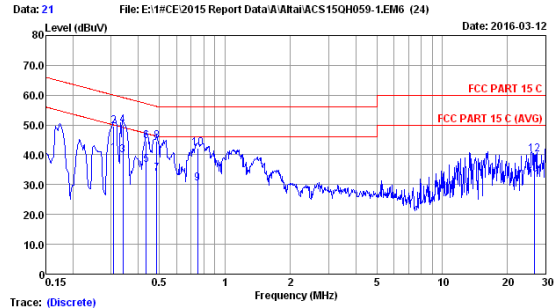

Trace: (Discrete)
 Site no :1# Conduction Data No :21
 Dis./Lisn :2015 ESH2-25 NEUTRAL
 Limit :FCC PART 15 C
 Env./Ins. :23.5°C/48% Engineer :Leo-Li
 EUT :Altai A3w Indoor Dual-band 3x3 802.11ac WiFi AP
 Power Rating :DC 56V From POE Input AC 120V/60Hz
 Test Mode :Tx Mode
 N/N:WA3311NAC-W

No	Freq (MHz)	LISN Factor (dB)	Cable Loss (dB)	Reading (dBuV)	Emission Level (dBuV)	Limits (dBuV)	Margin (dB)	Remark
1	0.308	0.13	0.05	40.20	40.38	50.02	9.64	Average
2	0.308	0.13	0.05	49.50	49.68	60.02	10.34	QP
3	0.340	0.13	0.06	39.60	39.79	49.20	9.41	Average
4	0.340	0.13	0.06	49.80	49.99	59.20	9.21	QP
5	0.435	0.14	0.06	36.50	36.70	47.16	10.46	Average
6	0.435	0.14	0.06	44.30	44.50	57.16	12.66	QP
7	0.486	0.14	0.06	33.60	33.80	46.24	12.44	Average
8	0.486	0.14	0.06	44.50	44.70	56.24	11.54	QP
9	0.750	0.15	0.07	30.20	30.42	46.00	15.58	Average
10	0.750	0.15	0.07	42.10	42.32	56.00	13.68	QP
11	26.558	1.13	0.37	30.10	31.60	50.00	18.40	Average
12	26.558	1.13	0.37	38.50	40.00	60.00	20.00	QP

Remarks: 1.Emission Level=LISN Factor+Cable Loss+Reading.
 2.If the average limit is met when using a quasi-peak detector, the EUT shall be deemed to meet both limits and measurement with average detector is unnecessary.

4. RADIATED EMISSION TEST

4.1. Test Equipment

4.1.1. For frequency range 30 MHz ~1000MHz (In 3m Anechoic Chamber)

Item	Equipment	Manufacturer	Model No.	Serial No.	Last Cal.	Cal. Interval
1.	3#Chamber	AUDIX	N/A	N/A	Mar.28,15	1 Year
2.	EMI Spectrum	Agilent	E4407B	MY41440292	Apr.28,15	1 Year
3.	Test Receiver	Rohde & Schwarz	ESVS10	834468/011	Apr.28,15	1 Year
4.	Amplifier	HP	8447D	2648A04738	Apr.28,15	1 Year
5.	Bilog Antenna	TESEQ	CBL6112D	35375	Jun.30,15	1 Year
6.	RF Cable	MIYAZAKI	CFD400-NW(3.5M)	No.3	Apr.28,15	1 Year
7.	RF Cable	MIYAZAKI	CFD400-LW(22M)	No.7	Apr.28,15	1 Year
8.	Coaxial Switch	Anritsu	MP59B	6201397222	Apr.28,15	1 Year
9.	Test Software	AUDIX	e3	6.2009-5-21a(n)	N/A	N/A

4.1.2. For frequency range 1GHz~40GHz (In 3m Anechoic Chamber)

Item	Equipment	Manufacturer	Model No.	Serial No.	Last Cal.	Cal. Interval
10.	Spectrum Analyzer	Agilent	E4446A	US44300459	Apr.28,15	1 Year
11.	Horn Antenna	ETS	3115	9510-4877	Oct.15,15	1 Year
12.	Amplifier	Agilent	8449B	3008A02495	Apr.28,15	1 Year
13.	RF Cable	Hubersuhner	SUCOFLEX106	77977/6	Apr.28,15	1 Year
14.	Horn Antenna	ETS	3116	00060088	Nov.18.15	1 Year
15.	Test Software	AUDIX	e3	6.2009-5-21a(n)	N/A	N/A

4.2. Block Diagram of Test Setup

For frequency range 30MHz-1000MHz

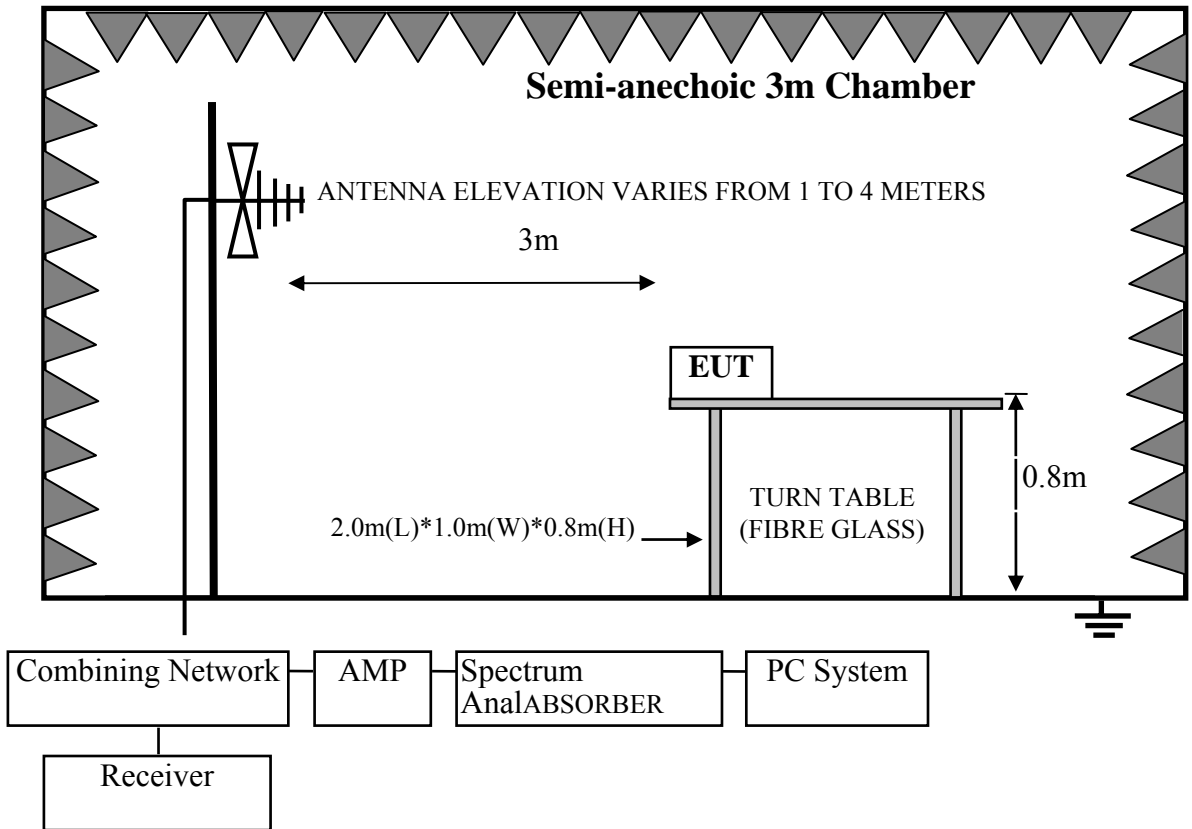

For frequency range 1GHz-40GHz

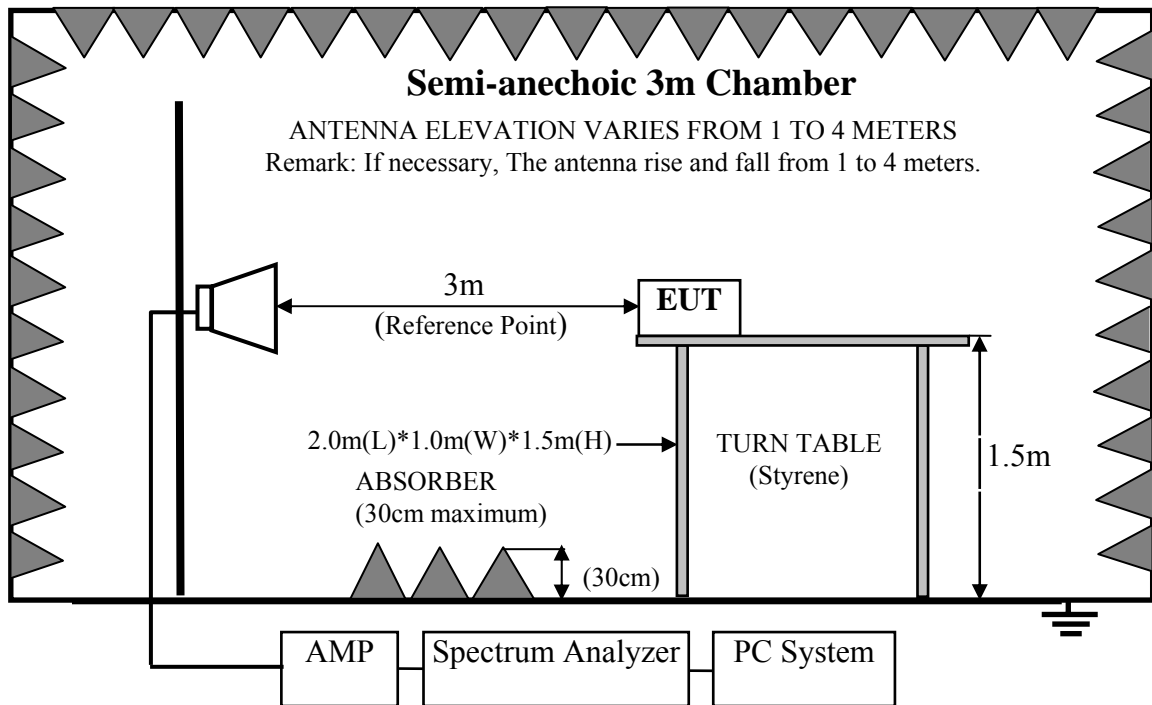

4.3. Radiated Emission Limit

For transmitters operating in the 5.15-5.25 GHz; 5.25-5.35GHz; 5.47-5.725GHz, 5.725-5.850GHz band: all emissions outside of those band shall not exceed an EIRP of -27 dBm/MHz. Unwanted emissions below 1 GHz and those emissions appearing within 15.205 restricted frequency bands must comply with the general field strength limits set forth in Section 15.209

4.3.1. 15.209 limits

FREQUENCY MHz	DISTANCE Meters	FIELD STRENGTHS LIMIT	
		μV/m	dB(μV)/m
30 ~ 88	3	100	40.0
88 ~ 216	3	150	43.5
216 ~ 960	3	200	46.0
960 ~ 1000	3	500	54.0
Above 1000	3	74.0 dB(μV)/m (Peak) 54.0 dB(μV)/m (Average)	

- Remarks :
- (1) Emission level dBμV = 20 log Emission level μV/m
 - (2) The smaller limit shall apply at the cross point between two frequency bands.
 - (3) Distance is the distance in meters between the measuring instrument, antenna and the closest point of any part of the device or system.

4.3.2. 15.205 Restricted bands of operation

MHz	MHz	MHz	GHz
0.090 - 0.110	16.42 - 16.423	399.9 - 410	4.5 - 5.15
¹ 0.495 - 0.505	16.69475 - 16.69525	608 - 614	5.35 - 5.46
2.1735 - 2.1905	16.80425 - 16.80475	960 - 1240	7.25 - 7.75
4.125 - 4.128	25.5 - 25.67	1300 - 1427	8.025 - 8.5
4.17725 - 4.17775	37.5 - 38.25	1435 - 1626.5	9.0 - 9.2
4.20725 - 4.20775	73 - 74.6	1645.5 - 1646.5	9.3 - 9.5
6.215 - 6.218	74.8 - 75.2	1660 - 1710	10.6 - 12.7
6.26775 - 6.26825	108 - 121.94	1718.8 - 1722.2	13.25 - 13.4
6.31175 - 6.31225	123 - 138	2200 - 2300	14.47 - 14.5
8.291 - 8.294	149.9 - 150.05	2310 - 2390	15.35 - 16.2
8.362 - 8.366	156.52475 - 156.52525	2483.5 - 2500	17.7 - 21.4
8.37625 - 8.38675	156.7 - 156.9	2690 - 2900	22.01 - 23.12
8.41425 - 8.41475	162.0125 - 167.17	3260 - 3267	23.6 - 24.0
12.29 - 12.293	167.72 - 173.2	3332 - 3339	31.2 - 31.8
12.51975 - 12.52025	240 - 285	3345.8 - 3358	36.43 - 36.5
12.57675 - 12.57725	322 - 335.4	3600 - 4400	(²)

4.4. EUT Configuration on Test

The following equipment are installed on Power Line Conducted Emission Test to meet the commission requirement and operating regulations in a manner which tends to maximize its emission characteristics in a normal application.

4.4.1. Altai A3w Indoor Dual-band 3X3 802.11ac WiFi AP (EUT)

Model Number : WA3311NAC-W

Serial Number : N/A

4.4.2. Support Equipment: As Tested Supporting System Details, in Section 2.2.

4.5. Operating Condition of EUT

- 4.5.1. Setup the EUT and simulator as shown as Section 4.2.
- 4.5.2. Turn on the power of all equipments.
- 4.5.3. Let EUT work in Tx mode.

4.6. Test Procedure

EUT and its simulators are placed on a turn table, which is 0.8 meter high above ground for frequency 30MHz~1000MHz, 1.5 meter high above ground for frequency above 1GHz and put the absorbing with 2.4m(L)*2.4m(W)*0.3m(H) on the ground . The turn table can rotate 360 degrees to determine the position of the maximum emission level. Power on the EUT and let it working in test mode, then test it. EUT is set 3 meters away from the receiving antenna, which is mounted on a antenna tower. The antenna can be moved up and down between 1 meter and 4 meters to find out the maximum emission level. Broadband antenna (calibrated bilog antenna) is used as receiving antenna for frequency 30MHz~1000MHz, and the Horn antenna is used as receiving antenna for frequency above 1GHz. Both horizontal and vertical polarization of the antenna is set on Test. In order to find the maximum emission levels, all of the interface cables must be manipulated according to ANSI C63.10-2013 on radiated emission Test.

For emissions below 1GHz and those emissions appearing within 15.205 restricted frequency bands use below procedure:

The bandwidth of the EMI test receiver (R&S ESVS10) is set at 120kHz for frequency range from 30MHz to 1000 MHz.

The bandwidth of the Spectrum's VBW is set at 1MHz and RBW is set at 1MHz for peak emissions measurement above 1GHz and 1MHz RBW, 10Hz VBW for average emissions measure above 1GHz

For the emissions above 1GHz and not appearing within 15.205 restricted frequency bands use below procedure:

- (1). The maximum emission at 3m distance was measured and recorded with receive antenna in both vertical and horizontal by rotating the turntable and by lowering the receive antenna.
- (2). The EUT was then removed and replaced with a substitution antenna in the same position and the substitution antenna must have the same polarization with the receive antenna.
- (3). A signal which have the same frequency obtained in step 2 was fed to the substitution, the receive antenna was raised and lowered to obtain a maximum reading at the test receiver, the level of the signal generator was adjusted until the measured field strength level in step 2 was obtained, recorded the level of the signal generator.
- (4). Repeated step 4 with both antenna polarizations
- (5). The spurious emissions is equal to the power supplied by the signal generator and corrections due to the gain of the substitution antenna and the cable loss between the signal generator and the substitution antenna. or use procedure (6).
- (6). Per KDB789033 clause H 2)d). if the test distance is 3m, the $EIRP(dBm) = E(dBuV/m) - 95.2$
Get the result of all unwanted emission outside the restricted band is less than the -27dBm/MHz.

We had checked frequency range that is 30MHz to 10th harmonic (40GHz) and no any emissions were found from 18GHz to 40GHz, so the radiated emission from 18GHz to 40GHz were not record.

4.7. Radiated Emission Test Results

PASS.

All the emissions from 30MHz to 1 GHz were comply with 15.209 limits.
All other emission comply with 15.407 (b)(1) requirements.

Duty cycle

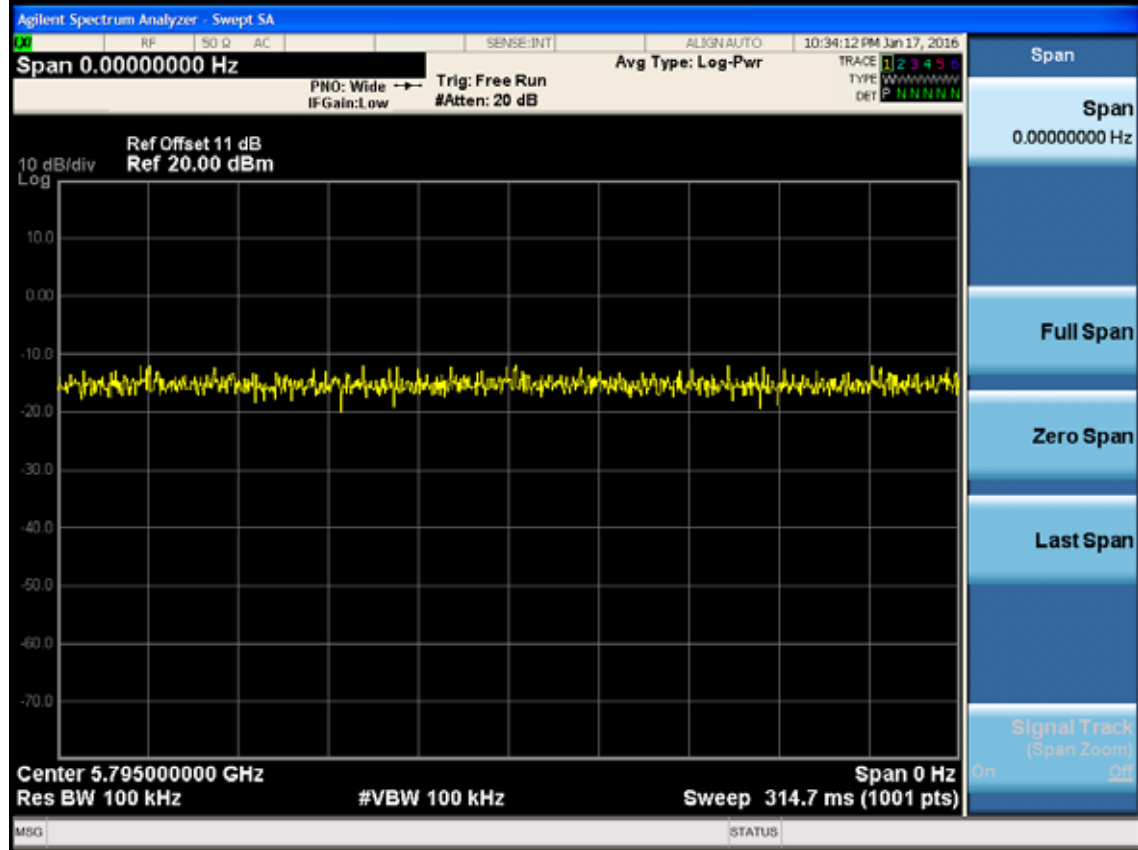

Note: The Duty Cycle is close to 100%.

Frequency: 30MHz~1GHz

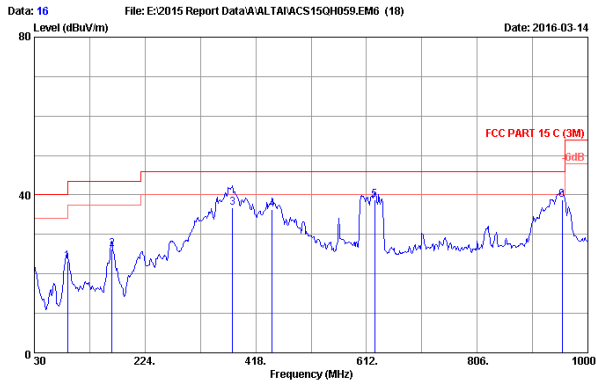

Data: 16 File: E:\2015 Report Data\A\ALTA\ACS15QH059.EM6 (18) Date: 2016-03-14

Site no. : 3m Chamber Data no. : 16
 Dis. / Ant. : 3m 2015 CBL6112D 35375 Ant. pol. : HORIZONTAL
 Limit : FCC PART 15 C (3M)
 Env. / Ins. : 23.9°C/57% Engineer : Leo-Li
 EUT : Alcatel A3w Indoor Dual-band 3x3 802.11ac WiFi AP
 Power rating : DC 56V From POE Input AC 120V/60Hz
 Test Mode : TX Mode
 M/N: WA3311NAC-W

No.	Freq. (MHz)	Ant. Factor (dB/m)	Cable Loss (dB)	Reading (dBuV)	Emission Level (dBuV/m)	Limits (dBuV/m)	Margin (dB)	Remark
1	88.200	9.48	1.06	12.56	23.10	43.50	20.40	QP
2	165.800	10.86	1.38	14.09	26.33	43.50	17.17	QP
3	377.265	16.30	2.14	18.40	36.84	46.00	9.16	QP
4	447.100	17.61	2.36	16.27	36.24	46.00	9.76	QP
5	626.550	19.51	2.84	16.33	38.68	46.00	7.32	QP
6	954.520	22.27	3.61	12.80	38.68	46.00	7.32	QP

Remarks: 1. Emission Level= Antenna Factor + Cable Loss + Reading.
 2. The emission levels that are 20dB below the official limit are not reported.

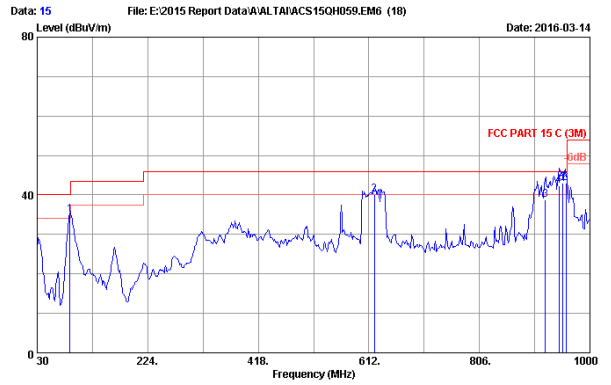

Data: 15 File: E:\2015 Report Data\A\ALTA\ACS15QH059.EM6 (18) Date: 2016-03-14

Site no. : 3m Chamber Data no. : 15
 Dis. / Ant. : 3m 2015 CBL6112D 35375 Ant. pol. : VERTICAL
 Limit : FCC PART 15 C (3M)
 Env. / Ins. : 23.9°C/57% Engineer : Leo-Li
 EUT : Alcatel A3w Indoor Dual-band 3x3 802.11ac WiFi AP
 Power rating : DC 56V From POE Input AC 120V/60Hz
 Test Mode : TX Mode
 M/N: WA3311NAC-W

No.	Freq. (MHz)	Ant. Factor (dB/m)	Cable Loss (dB)	Reading (dBuV)	Emission Level (dBuV/m)	Limits (dBuV/m)	Margin (dB)	Remark
1	87.658	9.27	1.06	24.60	34.93	40.00	5.07	QP
2	621.700	19.47	2.82	17.86	40.15	46.00	5.85	QP
3	921.526	22.11	3.55	13.09	38.75	46.00	7.25	QP
4	945.906	22.23	3.59	16.50	42.32	46.00	3.68	QP
5	951.744	22.26	3.61	17.10	42.97	46.00	3.03	QP
6	957.623	22.29	3.62	17.00	42.91	46.00	3.09	QP

Remarks: 1. Emission Level= Antenna Factor + Cable Loss + Reading.
 2. The emission levels that are 20dB below the official limit are not reported.

Frequency: 1GHz~18GHz

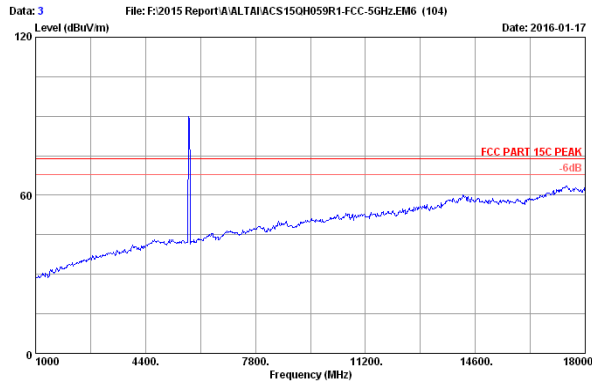

Site no. : 3m Chamber Data no. : 3
 Dis. / Ant. : 3m 2015 3115-4877 Ant. pol. : HORIZONTAL
 Limit : FCC PART 15C PEAK
 Env. / Ins. : 23°C/54%
 Engineer : Leo-Li
 EUT : Altai A3w Indoor Dual-band 3x3 802.11ac WiFi AP
 Power rating : DC 56V From POE Input AC 120V/60Hz
 Test Mode : IEEE802.11a 5745MHz Tx
 WA3311NAC-W

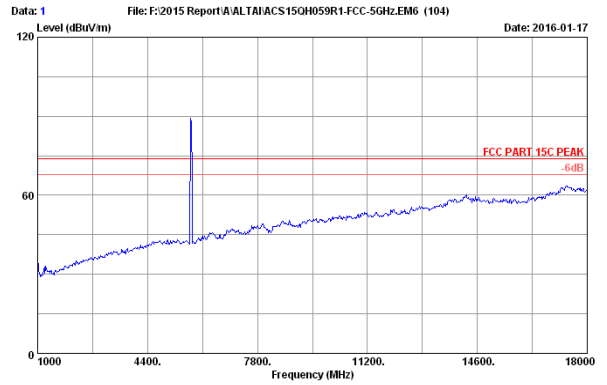

Site no. : 3m Chamber Data no. : 1
 Dis. / Ant. : 3m 2015 3115-4877 Ant. pol. : VERTICAL
 Limit : FCC PART 15C PEAK
 Env. / Ins. : 23°C/54%
 Engineer : Leo-Li
 EUT : Altai A3w Indoor Dual-band 3x3 802.11ac WiFi AP
 Power rating : DC 56V From POE Input AC 120V/60Hz
 Test Mode : IEEE802.11a 5745MHz Tx
 WA3311NAC-W

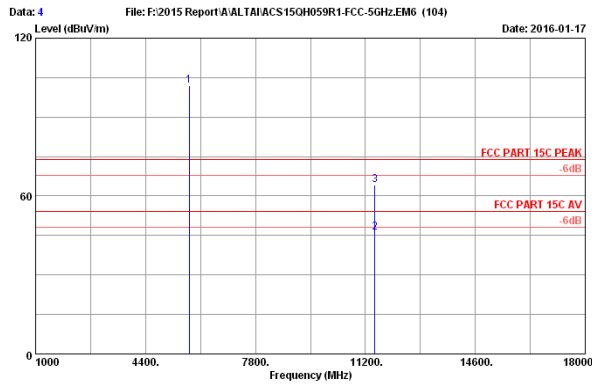

Site no. : 3m Chamber Data no. : 4
 Dis. / Ant. : 3m 2015 3115-4877 Ant. pol. : HORIZONTAL
 Limit : FCC PART 15C PEAK
 Env. / Ins. : 23°C/54%
 Engineer : Leo-Li
 EUT : Altai A3w Indoor Dual-band 3x3 802.11ac WiFi AP
 Power rating : DC 56V From POE Input AC 120V/60Hz
 Test Mode : IEEE802.11a 5745MHz Tx
 WA3311NAC-W

No.	Freq. (MHz)	Ant. Factor (dB/m)	Cable Loss (dB)	AMP factor (dB)	Reading (dBuV)	Emission Level (dBuV/m)	Limits (dBuV/m)	Margin (dB)	Remark
1	5745.000	34.55	9.90	35.11	92.50	101.84	74.00	-27.84	Peak
2	11490.000	39.09	14.54	35.33	27.83	46.13	54.00	7.87	Average
3	11490.000	39.09	14.54	35.33	45.76	64.06	74.00	9.94	Peak

Remarks: 1. Emission Level= Antenna Factor + Cable Loss + Reading - Amp Factor
 2. The emission levels that are 20dB below the official limit are not reported.

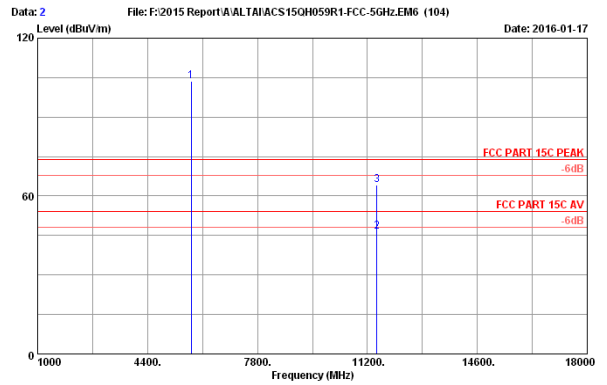

Site no. : 3m Chamber Data no. : 2
 Dis. / Ant. : 3m 2015 3115-4877 Ant. pol. : VERTICAL
 Limit : FCC PART 15C PEAK
 Env. / Ins. : 23°C/54%
 Engineer : Leo-Li
 EUT : Altai A3w Indoor Dual-band 3x3 802.11ac WiFi AP
 Power rating : DC 56V From POE Input AC 120V/60Hz
 Test Mode : IEEE802.11a 5745MHz Tx
 WA3311NAC-W

No.	Freq. (MHz)	Ant. Factor (dB/m)	Cable Loss (dB)	AMP factor (dB)	Reading (dBuV)	Emission Level (dBuV/m)	Limits (dBuV/m)	Margin (dB)	Remark
1	5745.000	34.55	9.90	35.11	94.43	103.77	74.00	-29.77	Peak
2	11490.000	39.09	14.54	35.33	28.10	46.40	54.00	7.60	Average
3	11490.000	39.09	14.54	35.33	45.90	64.20	74.00	9.80	Peak

Remarks: 1. Emission Level= Antenna Factor + Cable Loss + Reading - Amp Factor
 2. The emission levels that are 20dB below the official limit are not reported.

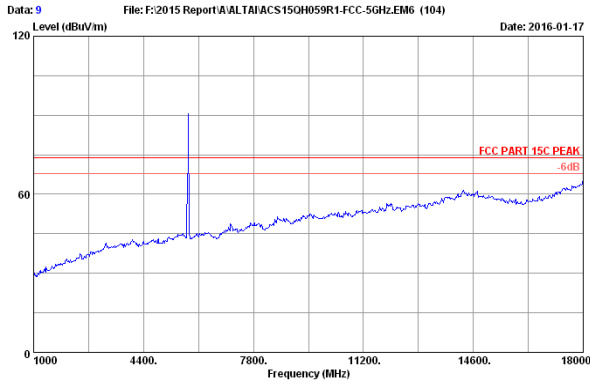

Site no. : 3m Chamber Data no. : 9
 Dis. / Ant. : 3m 2014 3115 9607-4877 Ant. pol. : HORIZONTAL
 Limit : FCC PART 15C PEAK
 Env. / Ins. : 23°C/54%
 Engineer : Leo-Li
 EUT : Altai A3w Indoor Dual-band 3x3 802.11ac WiFi AP
 Power rating : DC 56V From POE Input AC 120V/60Hz
 Test Mode : IEEE802.11a 5785MHz Tx
 WA3311NAC-W

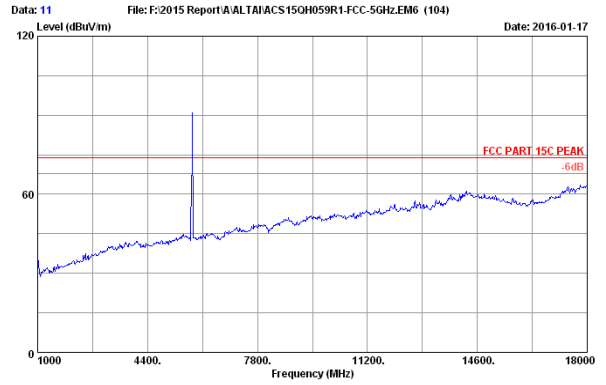

Site no. : 3m Chamber Data no. : 11
 Dis. / Ant. : 3m 2014 3115 9607-4877 Ant. pol. : VERTICAL
 Limit : FCC PART 15C PEAK
 Env. / Ins. : 23°C/54%
 Engineer : Leo-Li
 EUT : Altai A3w Indoor Dual-band 3x3 802.11ac WiFi AP
 Power rating : DC 56V From POE Input AC 120V/60Hz
 Test Mode : IEEE802.11a 5785MHz Tx
 WA3311NAC-W

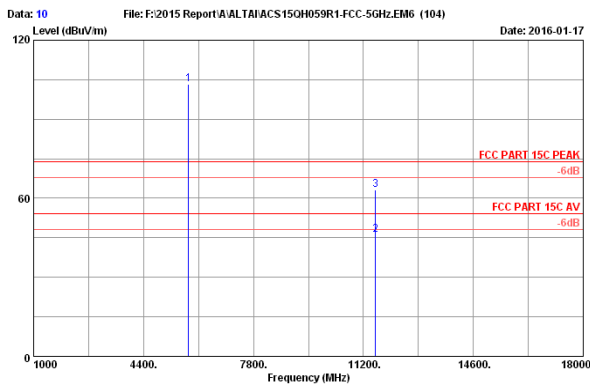

Site no. : 3m Chamber Data no. : 10
 Dis. / Ant. : 3m 2014 3115 9607-4877 Ant. pol. : HORIZONTAL
 Limit : FCC PART 15C PEAK
 Env. / Ins. : 23°C/54%
 Engineer : Leo-Li
 EUT : Altai A3w Indoor Dual-band 3x3 802.11ac WiFi AP
 Power rating : DC 56V From POE Input AC 120V/60Hz
 Test Mode : IEEE802.11a 5785MHz Tx
 WA3311NAC-W

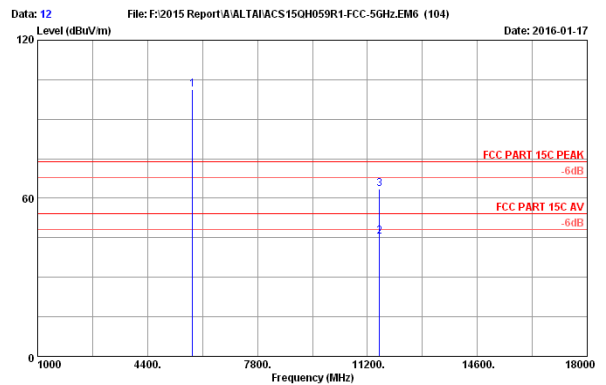

Site no. : 3m Chamber Data no. : 12
 Dis. / Ant. : 3m 2014 3115 9607-4877 Ant. pol. : VERTICAL
 Limit : FCC PART 15C PEAK
 Env. / Ins. : 23°C/54%
 Engineer : Leo-Li
 EUT : Altai A3w Indoor Dual-band 3x3 802.11ac WiFi AP
 Power rating : DC 56V From POE Input AC 120V/60Hz
 Test Mode : IEEE802.11a 5785MHz Tx
 WA3311NAC-W

No.	Freq. (MHz)	Ant. Factor (dB/m)	Cable Loss (dB)	AMP factor (dB)	Reading (dBuV)	Emission Level (dBuV/m)	Limits (dBuV/m)	Margin (dB)	Remark
1	5785.000	34.42	9.91	35.10	94.01	103.24	74.00	-29.24	Peak
2	11570.000	39.03	14.60	35.31	27.96	46.28	54.00	7.72	Average
3	11570.000	39.03	14.60	35.31	44.75	63.07	74.00	10.93	Peak

Remarks: 1. Emission Level= Antenna Factor + Cable Loss + Reading - Amp Factor
 2. The emission levels that are 20dB below the official limit are not reported.

No.	Freq. (MHz)	Ant. Factor (dB/m)	Cable Loss (dB)	AMP factor (dB)	Reading (dBuV)	Emission Level (dBuV/m)	Limits (dBuV/m)	Margin (dB)	Remark
1	5785.000	34.42	9.91	35.10	92.19	101.42	74.00	-27.42	Peak
2	11570.000	39.03	14.60	35.31	27.24	45.56	54.00	8.44	Average
3	11570.000	39.03	14.60	35.31	45.21	63.53	74.00	10.47	Peak

Remarks: 1. Emission Level= Antenna Factor + Cable Loss + Reading - Amp Factor
 2. The emission levels that are 20dB below the official limit are not reported.

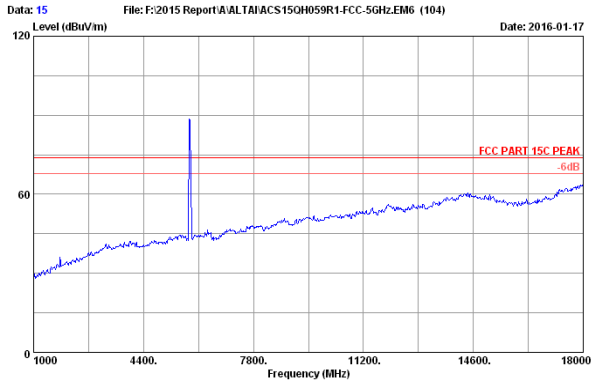

Site no. : 3m Chamber Data no. : 15
 Dis. / Ant. : 3m 2014 3115 9607-4877 Ant. pol. : HORIZONTAL
 Limit : FCC PART 15C PEAK
 Env. / Ins. : 23°C/54%
 Engineer : Leo-Li
 EUT : Altai A3w Indoor Dual-band 3x3 802.11ac WiFi AP
 Power rating : DC 56V From POE Input AC 120V/60Hz
 Test Mode : IEEE802.11a 5825MHz Tx
 WA3311NAC-W

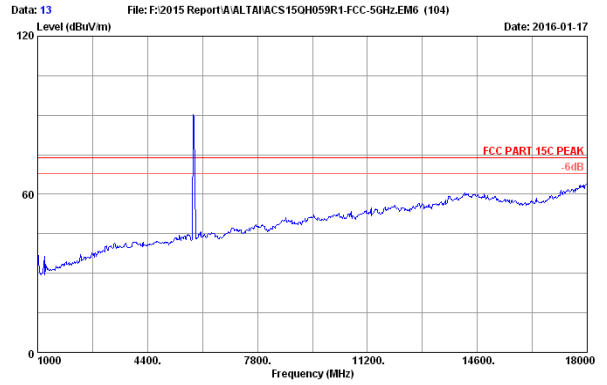

Site no. : 3m Chamber Data no. : 13
 Dis. / Ant. : 3m 2014 3115 9607-4877 Ant. pol. : VERTICAL
 Limit : FCC PART 15C PEAK
 Env. / Ins. : 23°C/54%
 Engineer : Leo-Li
 EUT : Altai A3w Indoor Dual-band 3x3 802.11ac WiFi AP
 Power rating : DC 56V From POE Input AC 120V/60Hz
 Test Mode : IEEE802.11a 5825MHz Tx
 WA3311NAC-W

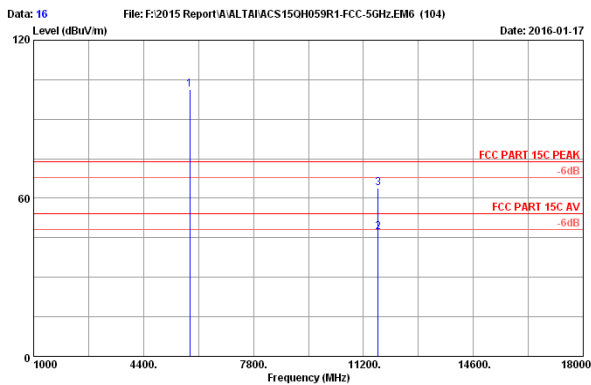

Site no. : 3m Chamber Data no. : 16
 Dis. / Ant. : 3m 2014 3115 9607-4877 Ant. pol. : HORIZONTAL
 Limit : FCC PART 15C PEAK
 Env. / Ins. : 23°C/54%
 Engineer : Leo-Li
 EUT : Altai A3w Indoor Dual-band 3x3 802.11ac WiFi AP
 Power rating : DC 56V From POE Input AC 120V/60Hz
 Test Mode : IEEE802.11a 5825MHz Tx
 WA3311NAC-W

No.	Freq. (MHz)	Ant. Factor (dB/m)	Cable Loss (dB)	AMP factor (dB)	Reading (dBuV)	Emission Level (dBuV/m)	Limits (dBuV/m)	Margin (dB)	Remark
1	5825.000	34.43	9.99	35.08	92.15	101.43	74.00	-27.43	Peak
2	11650.000	39.06	14.66	35.29	28.54	46.97	54.00	7.03	Average
3	11650.000	39.06	14.66	35.29	45.38	63.81	74.00	10.19	Peak

Remarks: 1. Emission Level= Antenna Factor + Cable Loss + Reading - Amp Factor
 2. The emission levels that are 20dB below the official limit are not reported.

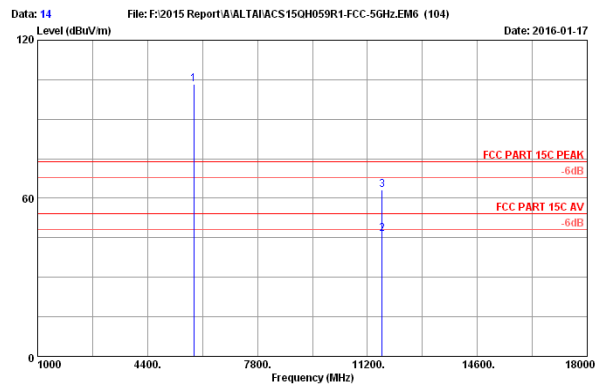

Site no. : 3m Chamber Data no. : 14
 Dis. / Ant. : 3m 2014 3115 9607-4877 Ant. pol. : VERTICAL
 Limit : FCC PART 15C PEAK
 Env. / Ins. : 23°C/54%
 Engineer : Leo-Li
 EUT : Altai A3w Indoor Dual-band 3x3 802.11ac WiFi AP
 Power rating : DC 56V From POE Input AC 120V/60Hz
 Test Mode : IEEE802.11a 5825MHz Tx
 WA3311NAC-W

No.	Freq. (MHz)	Ant. Factor (dB/m)	Cable Loss (dB)	AMP factor (dB)	Reading (dBuV)	Emission Level (dBuV/m)	Limits (dBuV/m)	Margin (dB)	Remark
1	5825.000	34.43	9.99	35.08	99.87	109.15	74.00	-29.15	Peak
2	11650.000	39.06	14.66	35.29	28.12	46.55	54.00	7.45	Average
3	11650.000	39.06	14.66	35.29	44.87	63.30	74.00	10.70	Peak

Remarks: 1. Emission Level= Antenna Factor + Cable Loss + Reading - Amp Factor
 2. The emission levels that are 20dB below the official limit are not reported.

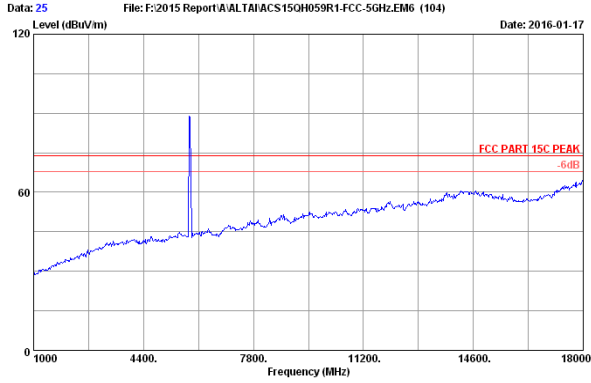

Site no. : 3m Chamber Data no. : 25
 Dis. / Ant. : 3m 2014 3115 9607-4877 Ant. pol. : HORIZONTAL
 Limit : FCC PART 15C PEAK
 Env. / Ins. : 23°C/54%
 Engineer : Leo-Li
 EUT : Altai A3w Indoor Dual-band 3x3 802.11ac WiFi AP
 Power rating : DC 56V From POE Input AC 120V/60Hz
 Test Mode : IEEE802.11nHT20 5825MHz Tx
 WA3311NAC-W

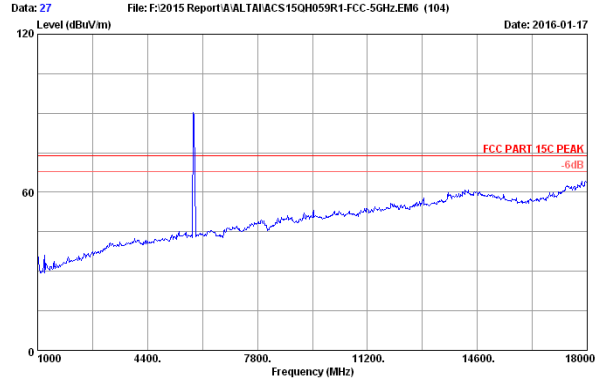

Site no. : 3m Chamber Data no. : 27
 Dis. / Ant. : 3m 2014 3115 9607-4877 Ant. pol. : VERTICAL
 Limit : FCC PART 15C PEAK
 Env. / Ins. : 23°C/54%
 Engineer : Leo-Li
 EUT : Altai A3w Indoor Dual-band 3x3 802.11ac WiFi AP
 Power rating : DC 56V From POE Input AC 120V/60Hz
 Test Mode : IEEE802.11nHT20 5825MHz Tx
 WA3311NAC-W

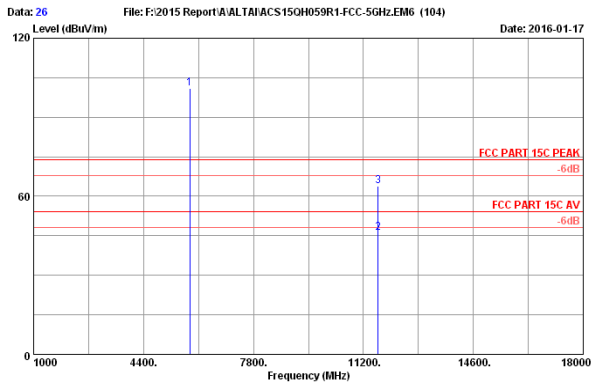

Site no. : 3m Chamber Data no. : 26
 Dis. / Ant. : 3m 2014 3115 9607-4877 Ant. pol. : HORIZONTAL
 Limit : FCC PART 15C PEAK
 Env. / Ins. : 23°C/54%
 Engineer : Leo-Li
 EUT : Altai A3w Indoor Dual-band 3x3 802.11ac WiFi AP
 Power rating : DC 56V From POE Input AC 120V/60Hz
 Test Mode : IEEE802.11nHT20 5825MHz Tx
 WA3311NAC-W

No.	Freq. (MHz)	Ant. Factor (dB/m)	Cable Loss (dB)	AMP factor (dB)	Reading (dBuV)	Emission Level (dBuV/m)	Limits (dBuV/m)	Margin (dB)	Remark
1	5825.000	34.43	9.93	35.08	91.78	101.06	74.00	-27.06	Peak
2	11650.000	39.06	14.66	35.29	27.85	46.28	54.00	7.72	Average
3	11650.000	39.06	14.66	35.29	45.34	63.77	74.00	10.23	Peak

Remarks: 1. Emission Level= Antenna Factor + Cable Loss + Reading - Amp Factor
 2. The emission levels that are 20dB below the official limit are not reported.

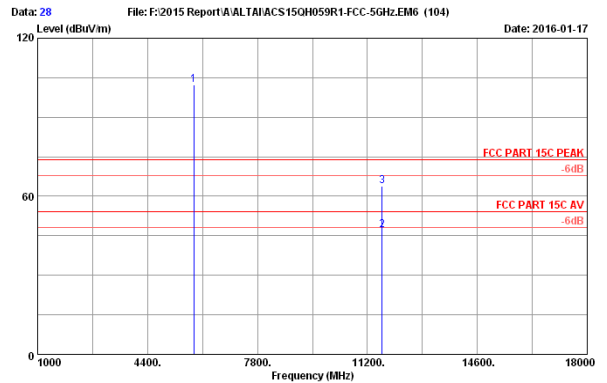

Site no. : 3m Chamber Data no. : 28
 Dis. / Ant. : 3m 2014 3115 9607-4877 Ant. pol. : VERTICAL
 Limit : FCC PART 15C PEAK
 Env. / Ins. : 23°C/54%
 Engineer : Leo-Li
 EUT : Altai A3w Indoor Dual-band 3x3 802.11ac WiFi AP
 Power rating : DC 56V From POE Input AC 120V/60Hz
 Test Mode : IEEE802.11nHT20 5825MHz Tx
 WA3311NAC-W

No.	Freq. (MHz)	Ant. Factor (dB/m)	Cable Loss (dB)	AMP factor (dB)	Reading (dBuV)	Emission Level (dBuV/m)	Limits (dBuV/m)	Margin (dB)	Remark
1	5825.000	34.43	9.93	35.08	99.15	102.43	74.00	-28.43	Peak
2	11650.000	39.06	14.66	35.29	28.67	47.10	54.00	6.90	Average
3	11650.000	39.06	14.66	35.29	45.36	63.79	74.00	10.21	Peak

Remarks: 1. Emission Level= Antenna Factor + Cable Loss + Reading - Amp Factor
 2. The emission levels that are 20dB below the official limit are not reported.

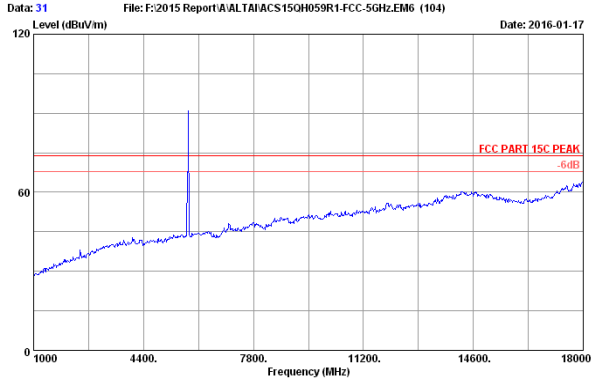

Site no. : 3m Chamber Data no. : 31
 Dis. / Ant. : 3m 2014 3115 9607-4877 Ant. pol. : HORIZONTAL
 Limit : FCC PART 15C PEAK
 Env. / Ins. : 23°C/54%
 Engineer : Leo-Li
 EUT : Altai A3w Indoor Dual-band 3x3 802.11ac WiFi AP
 Power rating : DC 56V From POE Input AC 120V/60Hz
 Test Mode : IEEE802.11nHT20 5785MHz Tx
 WA3311NAC-W

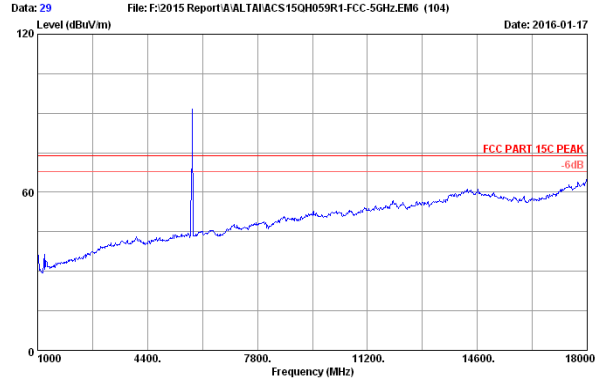

Site no. : 3m Chamber Data no. : 29
 Dis. / Ant. : 3m 2014 3115 9607-4877 Ant. pol. : VERTICAL
 Limit : FCC PART 15C PEAK
 Env. / Ins. : 23°C/54%
 Engineer : Leo-Li
 EUT : Altai A3w Indoor Dual-band 3x3 802.11ac WiFi AP
 Power rating : DC 56V From POE Input AC 120V/60Hz
 Test Mode : IEEE802.11nHT20 5785MHz Tx
 WA3311NAC-W

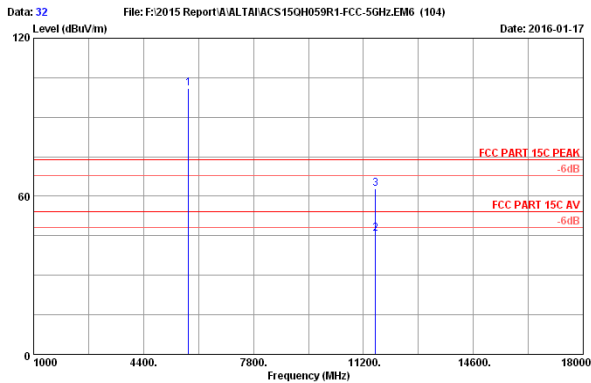

Site no. : 3m Chamber Data no. : 32
 Dis. / Ant. : 3m 2014 3115 9607-4877 Ant. pol. : HORIZONTAL
 Limit : FCC PART 15C PEAK
 Env. / Ins. : 23°C/54%
 Engineer : Leo-Li
 EUT : Altai A3w Indoor Dual-band 3x3 802.11ac WiFi AP
 Power rating : DC 56V From POE Input AC 120V/60Hz
 Test Mode : IEEE802.11nHT20 5785MHz Tx
 WA3311NAC-W

No.	Freq. (MHz)	Ant. Factor (dB/m)	Cable Loss (dB)	AMP factor (dB)	Reading (dBuV)	Emission Level (dBuV/m)	Limits (dBuV/m)	Margin (dB)	Remark
1	5785.000	34.42	9.91	35.10	91.88	101.11	74.00	-27.11	Peak
2	11570.000	39.03	14.60	35.31	27.52	45.84	54.00	8.16	Average
3	11570.000	39.03	14.60	35.31	44.38	62.70	74.00	11.30	Peak

Remarks: 1. Emission Level= Antenna Factor + Cable Loss + Reading - Amp Factor
 2. The emission levels that are 20dB below the official limit are not reported.

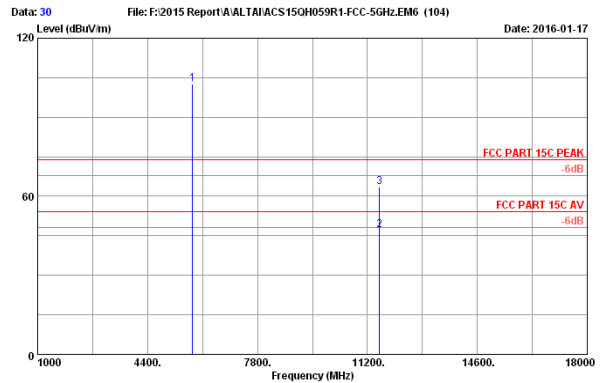

Site no. : 3m Chamber Data no. : 30
 Dis. / Ant. : 3m 2014 3115 9607-4877 Ant. pol. : VERTICAL
 Limit : FCC PART 15C PEAK
 Env. / Ins. : 23°C/54%
 Engineer : Leo-Li
 EUT : Altai A3w Indoor Dual-band 3x3 802.11ac WiFi AP
 Power rating : DC 56V From POE Input AC 120V/60Hz
 Test Mode : IEEE802.11nHT20 5785MHz Tx
 WA3311NAC-W

No.	Freq. (MHz)	Ant. Factor (dB/m)	Cable Loss (dB)	AMP factor (dB)	Reading (dBuV)	Emission Level (dBuV/m)	Limits (dBuV/m)	Margin (dB)	Remark
1	5785.000	34.42	9.91	35.10	99.47	102.70	74.00	-28.70	Peak
2	11570.000	39.03	14.60	35.31	28.67	46.99	54.00	7.01	Average
3	11570.000	39.03	14.60	35.31	45.32	63.64	74.00	10.36	Peak

Remarks: 1. Emission Level= Antenna Factor + Cable Loss + Reading - Amp Factor
 2. The emission levels that are 20dB below the official limit are not reported.

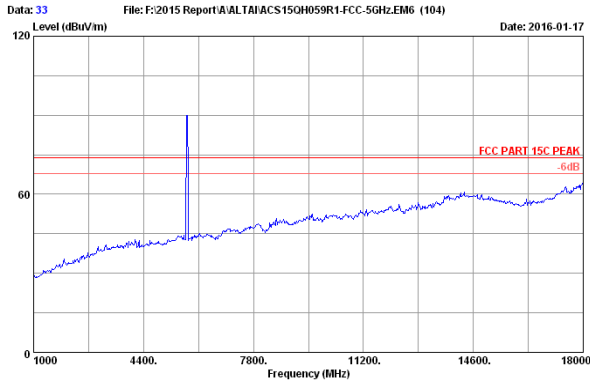

Site no. : 3m Chamber Data no. : 33
 Dis. / Ant. : 3m 2014 3115 9607-4877 Ant. pol. : HORIZONTAL
 Limit : FCC PART 15C PEAK
 Env. / Ins. : 23°C/54%
 Engineer : Leo-Li
 EUT : Altai A3w Indoor Dual-band 3x3 802.11ac WiFi AP
 Power rating : DC 56V From POE Input AC 120V/60Hz
 Test Mode : IEEE802.11nHT20 5745MHz Tx
 WA3311NAC-W

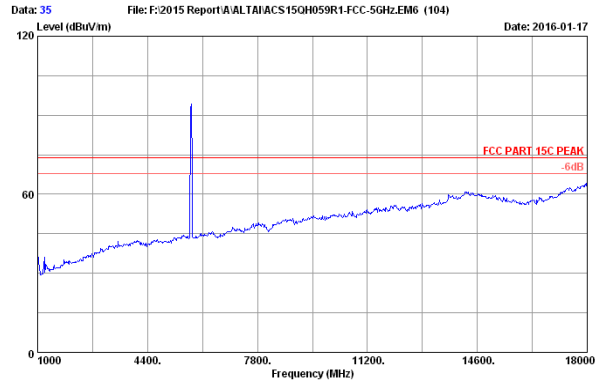

Site no. : 3m Chamber Data no. : 35
 Dis. / Ant. : 3m 2014 3115 9607-4877 Ant. pol. : VERTICAL
 Limit : FCC PART 15C PEAK
 Env. / Ins. : 23°C/54%
 Engineer : Leo-Li
 EUT : Altai A3w Indoor Dual-band 3x3 802.11ac WiFi AP
 Power rating : DC 56V From POE Input AC 120V/60Hz
 Test Mode : IEEE802.11nHT20 5745MHz Tx
 WA3311NAC-W

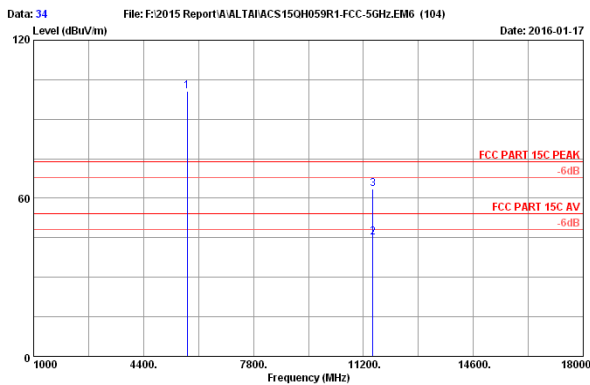

Site no. : 3m Chamber Data no. : 34
 Dis. / Ant. : 3m 2014 3115 9607-4877 Ant. pol. : HORIZONTAL
 Limit : FCC PART 15C PEAK
 Env. / Ins. : 23°C/54%
 Engineer : Leo-Li
 EUT : Altai A3w Indoor Dual-band 3x3 802.11ac WiFi AP
 Power rating : DC 56V From POE Input AC 120V/60Hz
 Test Mode : IEEE802.11nHT20 5745MHz Tx
 WA3311NAC-W

No.	Freq. (MHz)	Ant. Factor (dB/m)	Cable Loss (dB)	AMP factor (dB)	Reading (dBuV)	Emission Level (dBuV/m)	Limits (dBuV/m)	Margin (dB)	Remark
1	5745.000	34.40	9.90	35.11	91.57	100.76	74.00	-26.76	Peak
2	11490.000	38.99	14.54	35.33	26.99	45.19	54.00	8.81	Average
3	11490.000	38.99	14.54	35.33	45.32	63.52	74.00	10.48	Peak

Remarks: 1. Emission Level= Antenna Factor + Cable Loss + Reading - Amp Factor
 2. The emission levels that are 20dB below the official limit are not reported.

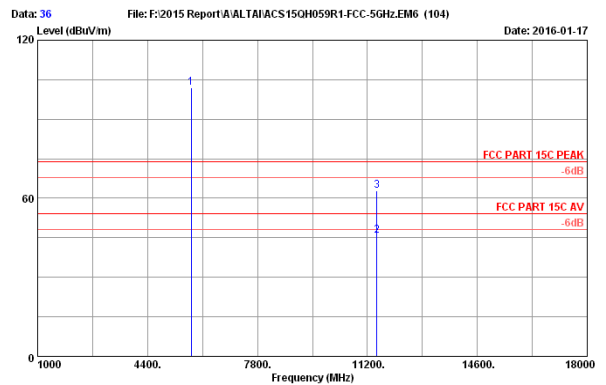

Site no. : 3m Chamber Data no. : 36
 Dis. / Ant. : 3m 2014 3115 9607-4877 Ant. pol. : VERTICAL
 Limit : FCC PART 15C PEAK
 Env. / Ins. : 23°C/54%
 Engineer : Leo-Li
 EUT : Altai A3w Indoor Dual-band 3x3 802.11ac WiFi AP
 Power rating : DC 56V From POE Input AC 120V/60Hz
 Test Mode : IEEE802.11nHT20 5745MHz Tx
 WA3311NAC-W

No.	Freq. (MHz)	Ant. Factor (dB/m)	Cable Loss (dB)	AMP factor (dB)	Reading (dBuV)	Emission Level (dBuV/m)	Limits (dBuV/m)	Margin (dB)	Remark
1	5745.000	34.40	9.90	35.11	92.73	101.92	74.00	-27.92	Peak
2	11490.000	38.99	14.54	35.33	27.55	45.75	54.00	8.25	Average
3	11490.000	38.99	14.54	35.33	44.64	62.84	74.00	11.16	Peak

Remarks: 1. Emission Level= Antenna Factor + Cable Loss + Reading - Amp Factor
 2. The emission levels that are 20dB below the official limit are not reported.

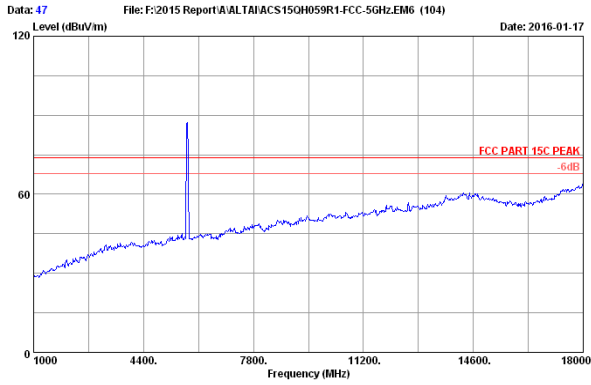

Site no. : 3m Chamber Data no. : 47
 Dis. / Ant. : 3m 2014 3115 9607-4877 Ant. pol. : HORIZONTAL
 Limit : FCC PART 15C PEAK
 Env. / Ins. : 23°C/54%
 Engineer : Leo-Li
 EUT : Altai A3w Indoor Dual-band 3x3 802.11ac WiFi AP
 Power rating : DC 56V From POE Input AC 120V/60Hz
 Test Mode : IEEE802.11nHT40 5755MHz Tx
 WA3311NAC-W

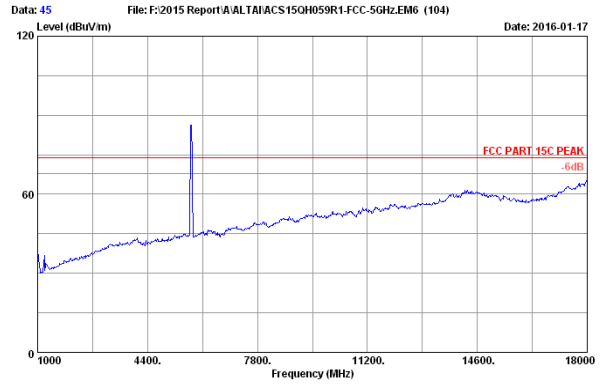

Site no. : 3m Chamber Data no. : 45
 Dis. / Ant. : 3m 2014 3115 9607-4877 Ant. pol. : VERTICAL
 Limit : FCC PART 15C PEAK
 Env. / Ins. : 23°C/54%
 Engineer : Leo-Li
 EUT : Altai A3w Indoor Dual-band 3x3 802.11ac WiFi AP
 Power rating : DC 56V From POE Input AC 120V/60Hz
 Test Mode : IEEE802.11nHT40 5755MHz Tx
 WA3311NAC-W

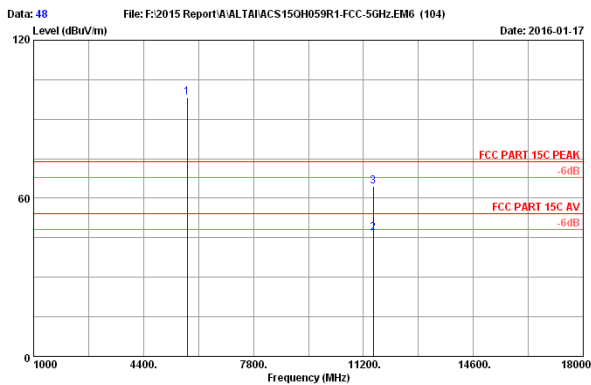

Site no. : 3m Chamber Data no. : 48
 Dis. / Ant. : 3m 2014 3115 9607-4877 Ant. pol. : HORIZONTAL
 Limit : FCC PART 15C PEAK
 Env. / Ins. : 23°C/54%
 Engineer : Leo-Li
 EUT : Altai A3w Indoor Dual-band 3x3 802.11ac WiFi AP
 Power rating : DC 56V From POE Input AC 120V/60Hz
 Test Mode : IEEE802.11nHT40 5755MHz Tx
 WA3311NAC-W

No.	Freq. (MHz)	Ant. Factor (dB/m)	Cable Loss (dB)	AMP factor (dB)	Reading (dBuV)	Emission Level (dBuV/m)	Limits (dBuV/m)	Margin (dB)	Remark
1	5755.000	34.40	9.91	35.11	89.24	98.44	74.00	-24.44	Peak
2	11510.000	39.00	14.56	35.33	28.56	46.79	54.00	7.21	Average
3	11510.000	39.00	14.56	35.33	46.32	64.55	74.00	9.45	Peak

Remarks: 1. Emission Level= Antenna Factor + Cable Loss + Reading - Amp Factor
 2. The emission levels that are 20dB below the official limit are not reported.

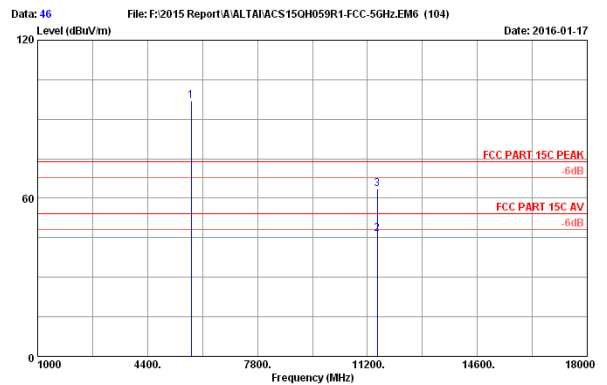

Site no. : 3m Chamber Data no. : 46
 Dis. / Ant. : 3m 2014 3115 9607-4877 Ant. pol. : VERTICAL
 Limit : FCC PART 15C PEAK
 Env. / Ins. : 23°C/54%
 Engineer : Leo-Li
 EUT : Altai A3w Indoor Dual-band 3x3 802.11ac WiFi AP
 Power rating : DC 56V From POE Input AC 120V/60Hz
 Test Mode : IEEE802.11nHT40 5755MHz Tx
 WA3311NAC-W

No.	Freq. (MHz)	Ant. Factor (dB/m)	Cable Loss (dB)	AMP factor (dB)	Reading (dBuV)	Emission Level (dBuV/m)	Limits (dBuV/m)	Margin (dB)	Remark
1	5755.000	34.40	9.91	35.11	87.85	97.05	74.00	-23.05	Peak
2	11510.000	39.00	14.56	35.33	28.18	46.41	54.00	7.59	Average
3	11510.000	39.00	14.56	35.33	45.32	63.55	74.00	10.45	Peak

Remarks: 1. Emission Level= Antenna Factor + Cable Loss + Reading - Amp Factor
 2. The emission levels that are 20dB below the official limit are not reported.

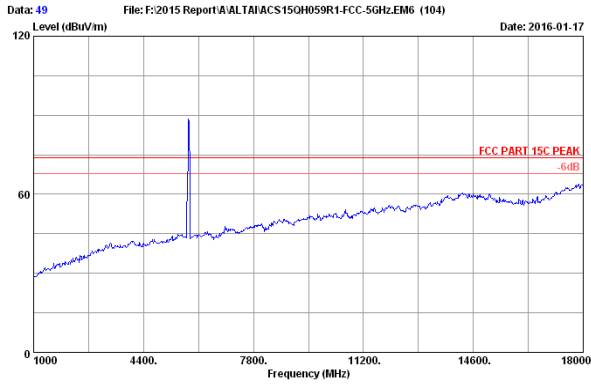

Site no. : 3m Chamber Data no. : 49
 Dis. / Ant. : 3m 2014 3115 9607-4877 Ant. pol. : HORIZONTAL
 Limit : FCC PART 15C PEAK
 Env. / Ins. : 23°C/54%
 Engineer : Leo-Li
 EUT : Altai A3w Indoor Dual-band 3x3 802.11ac WiFi AP
 Power rating : DC 56V From POE Input AC 120V/60Hz
 Test Mode : IEEE802.11nHT40 5795MHz Tx
 WA3311NAC-W

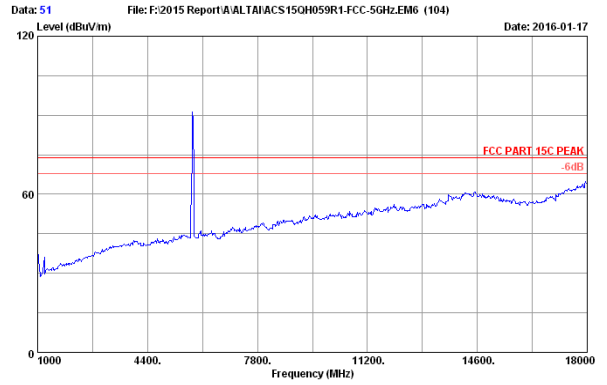

Site no. : 3m Chamber Data no. : 51
 Dis. / Ant. : 3m 2014 3115 9607-4877 Ant. pol. : VERTICAL
 Limit : FCC PART 15C PEAK
 Env. / Ins. : 23°C/54%
 Engineer : Leo-Li
 EUT : Altai A3w Indoor Dual-band 3x3 802.11ac WiFi AP
 Power rating : DC 56V From POE Input AC 120V/60Hz
 Test Mode : IEEE802.11nHT40 5795MHz Tx
 WA3311NAC-W

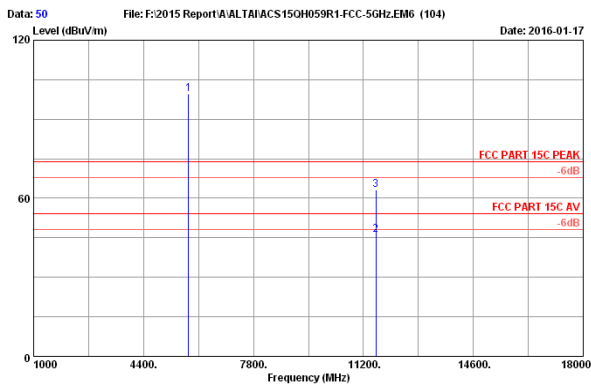

Site no. : 3m Chamber Data no. : 50
 Dis. / Ant. : 3m 2014 3115 9607-4877 Ant. pol. : HORIZONTAL
 Limit : FCC PART 15C PEAK
 Env. / Ins. : 23°C/54%
 Engineer : Leo-Li
 EUT : Altai A3w Indoor Dual-band 3x3 802.11ac WiFi AP
 Power rating : DC 56V From POE Input AC 120V/60Hz
 Test Mode : IEEE802.11nHT40 5795MHz Tx
 WA3311NAC-W

No.	Freq. (MHz)	Ant. Factor (dB/m)	Cable Loss (dB)	AMP factor (dB)	Reading (dBuV)	Emission Level (dBuV/m)	Limits (dBuV/m)	Margin (dB)	Remark
1	5795.000	34.42	9.92	35.09	90.42	99.67	74.00	-25.67	Peak
2	11590.000	39.04	14.61	35.30	27.82	46.17	54.00	7.83	Average
3	11590.000	39.04	14.61	35.30	44.75	63.10	74.00	10.90	Peak

Remarks: 1. Emission Level= Antenna Factor + Cable Loss + Reading - Amp Factor
 2. The emission levels that are 20dB below the official limit are not reported.

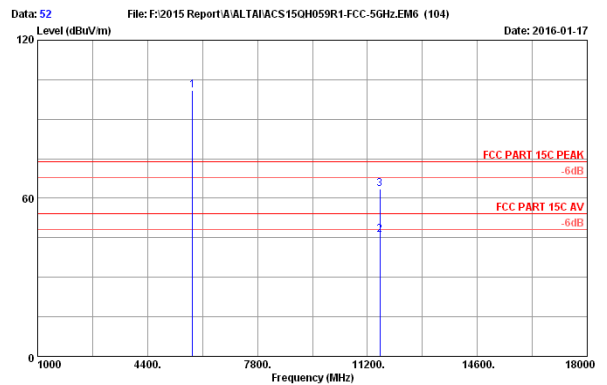

Site no. : 3m Chamber Data no. : 52
 Dis. / Ant. : 3m 2014 3115 9607-4877 Ant. pol. : VERTICAL
 Limit : FCC PART 15C PEAK
 Env. / Ins. : 23°C/54%
 Engineer : Leo-Li
 EUT : Altai A3w Indoor Dual-band 3x3 802.11ac WiFi AP
 Power rating : DC 56V From POE Input AC 120V/60Hz
 Test Mode : IEEE802.11nHT40 5795MHz Tx
 WA3311NAC-W

No.	Freq. (MHz)	Ant. Factor (dB/m)	Cable Loss (dB)	AMP factor (dB)	Reading (dBuV)	Emission Level (dBuV/m)	Limits (dBuV/m)	Margin (dB)	Remark
1	5795.000	34.42	9.92	35.09	91.86	101.11	74.00	-27.11	Peak
2	11590.000	39.04	14.61	35.30	27.84	46.19	54.00	7.81	Average
3	11590.000	39.04	14.61	35.30	45.29	63.64	74.00	10.36	Peak

Remarks: 1. Emission Level= Antenna Factor + Cable Loss + Reading - Amp Factor
 2. The emission levels that are 20dB below the official limit are not reported.

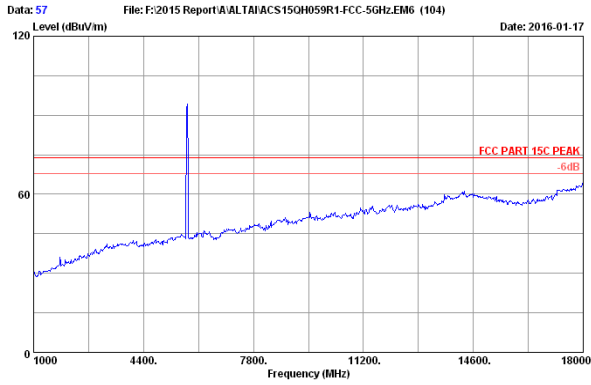

Site no. : 3m Chamber Data no. : 57
 Dis. / Ant. : 3m 2014 3115 9607-4877 Ant. pol. : HORIZONTAL
 Limit : FCC PART 15C PEAK
 Env. / Ins. : 23°C/54%
 Engineer : Leo-Li
 EUT : Altai A3w Indoor Dual-band 3x3 802.11ac WiFi AP
 Power rating : DC 56V From POE Input AC 120V/60Hz
 Test Mode : IEEE802.11ac VHT20 5745MHz Tx
 WA3311NAC-W

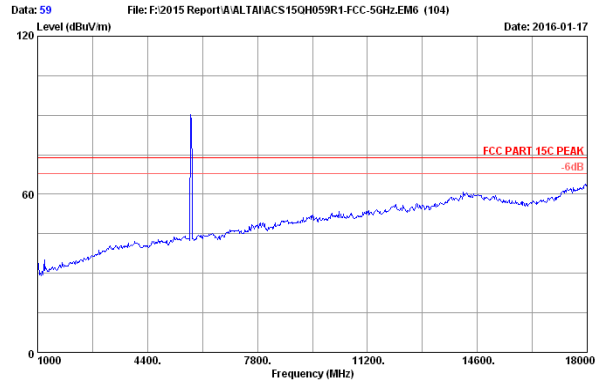

Site no. : 3m Chamber Data no. : 59
 Dis. / Ant. : 3m 2014 3115 9607-4877 Ant. pol. : VERTICAL
 Limit : FCC PART 15C PEAK
 Env. / Ins. : 23°C/54%
 Engineer : Leo-Li
 EUT : Altai A3w Indoor Dual-band 3x3 802.11ac WiFi AP
 Power rating : DC 56V From POE Input AC 120V/60Hz
 Test Mode : IEEE802.11ac VHT20 5745MHz Tx
 WA3311NAC-W

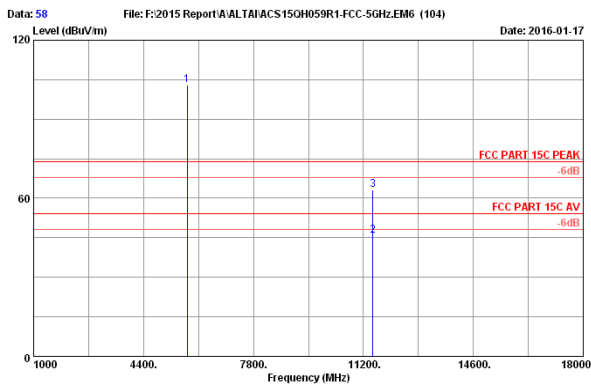

Site no. : 3m Chamber Data no. : 58
 Dis. / Ant. : 3m 2014 3115 9607-4877 Ant. pol. : HORIZONTAL
 Limit : FCC PART 15C PEAK
 Env. / Ins. : 23°C/54%
 Engineer : Leo-Li
 EUT : Altai A3w Indoor Dual-band 3x3 802.11ac WiFi AP
 Power rating : DC 56V From POE Input AC 120V/60Hz
 Test Mode : IEEE802.11ac VHT20 5745MHz Tx
 WA3311NAC-W

No.	Freq. (MHz)	Ant. Factor (dB/m)	Cable Loss (dB)	AMP factor (dB)	Reading (dBuV)	Emission Level (dBuV/m)	Limits (dBuV/m)	Margin (dB)	Remark
1	5745.000	34.40	9.90	35.11	93.75	102.94	74.00	-28.94	Peak
2	11490.000	38.99	14.54	35.33	27.46	45.66	54.00	8.34	Average
3	11490.000	38.99	14.54	35.33	44.87	63.07	74.00	10.93	Peak

Remarks: 1. Emission Level= Antenna Factor + Cable Loss + Reading - Amp Factor
 2. The emission levels that are 20dB below the official limit are not reported.

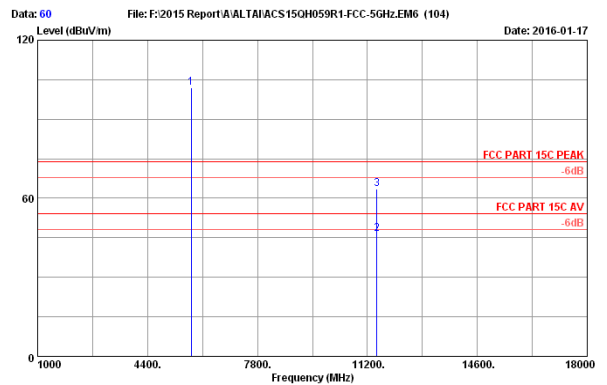

Site no. : 3m Chamber Data no. : 60
 Dis. / Ant. : 3m 2014 3115 9607-4877 Ant. pol. : VERTICAL
 Limit : FCC PART 15C PEAK
 Env. / Ins. : 23°C/54%
 Engineer : Leo-Li
 EUT : Altai A3w Indoor Dual-band 3x3 802.11ac WiFi AP
 Power rating : DC 56V From POE Input AC 120V/60Hz
 Test Mode : IEEE802.11ac VHT20 5745MHz Tx
 WA3311NAC-W

No.	Freq. (MHz)	Ant. Factor (dB/m)	Cable Loss (dB)	AMP factor (dB)	Reading (dBuV)	Emission Level (dBuV/m)	Limits (dBuV/m)	Margin (dB)	Remark
1	5745.000	34.40	9.90	35.11	92.86	102.05	74.00	-28.05	Peak
2	11490.000	38.99	14.54	35.33	28.27	46.47	54.00	7.53	Average
3	11490.000	38.99	14.54	35.33	45.39	63.59	74.00	10.41	Peak

Remarks: 1. Emission Level= Antenna Factor + Cable Loss + Reading - Amp Factor
 2. The emission levels that are 20dB below the official limit are not reported.

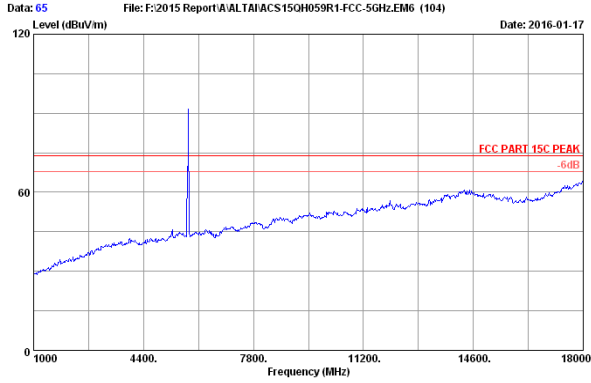

Site no. : 3m Chamber Data no. : 65
 Dis. / Ant. : 3m 2014 3115 9607-4877 Ant. pol. : HORIZONTAL
 Limit : FCC PART 15C PEAK
 Env. / Ins. : 23°C/54%
 Engineer : Leo-Li
 EUT : Altai A3w Indoor Dual-band 3x3 802.11ac WiFi AP
 Power rating : DC 56V From POE Input AC 120V/60Hz
 Test Mode : IEEE802.11ac VHT20 5785MHz Tx
 WA3311NAC-W

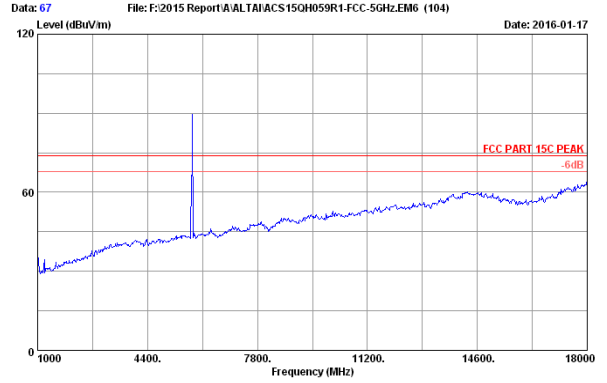

Site no. : 3m Chamber Data no. : 67
 Dis. / Ant. : 3m 2014 3115 9607-4877 Ant. pol. : VERTICAL
 Limit : FCC PART 15C PEAK
 Env. / Ins. : 23°C/54%
 Engineer : Leo-Li
 EUT : Altai A3w Indoor Dual-band 3x3 802.11ac WiFi AP
 Power rating : DC 56V From POE Input AC 120V/60Hz
 Test Mode : IEEE802.11ac VHT20 5785MHz Tx
 WA3311NAC-W

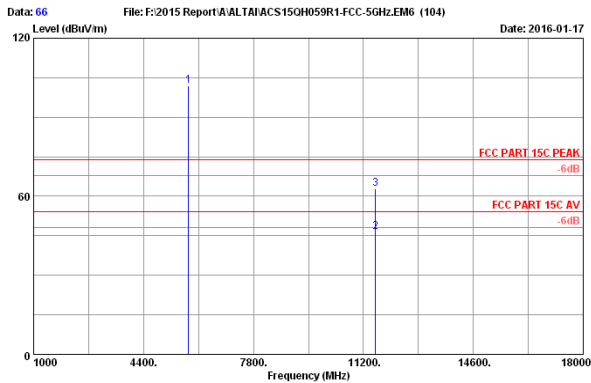

Site no. : 3m Chamber Data no. : 66
 Dis. / Ant. : 3m 2014 3115 9607-4877 Ant. pol. : HORIZONTAL
 Limit : FCC PART 15C PEAK
 Env. / Ins. : 23°C/54%
 Engineer : Leo-Li
 EUT : Altai A3w Indoor Dual-band 3x3 802.11ac WiFi AP
 Power rating : DC 56V From POE Input AC 120V/60Hz
 Test Mode : IEEE802.11ac VHT20 5785MHz Tx
 WA3311NAC-W

No.	Freq. (MHz)	Ant. Factor (dB/m)	Cable Loss (dB)	AMP factor (dB)	Reading (dBuV)	Emission Level (dBuV/m)	Limits (dBuV/m)	Margin (dB)	Remark
1	5785.000	34.42	9.91	35.10	92.87	102.10	74.00	-28.10	Peak
2	11570.000	39.03	14.60	35.31	28.23	46.55	54.00	7.45	Average
3	11570.000	39.03	14.60	35.31	44.62	62.94	74.00	11.06	Peak

Remarks: 1. Emission Level= Antenna Factor + Cable Loss + Reading - Amp Factor
 2. The emission levels that are 20dB below the official limit are not reported.

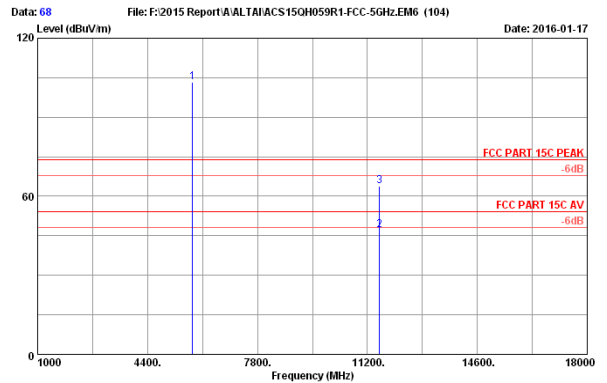

Site no. : 3m Chamber Data no. : 68
 Dis. / Ant. : 3m 2014 3115 9607-4877 Ant. pol. : VERTICAL
 Limit : FCC PART 15C PEAK
 Env. / Ins. : 23°C/54%
 Engineer : Leo-Li
 EUT : Altai A3w Indoor Dual-band 3x3 802.11ac WiFi AP
 Power rating : DC 56V From POE Input AC 120V/60Hz
 Test Mode : IEEE802.11ac VHT20 5785MHz Tx
 WA3311NAC-W

No.	Freq. (MHz)	Ant. Factor (dB/m)	Cable Loss (dB)	AMP factor (dB)	Reading (dBuV)	Emission Level (dBuV/m)	Limits (dBuV/m)	Margin (dB)	Remark
1	5785.000	34.42	9.91	35.10	99.92	109.15	74.00	-29.15	Peak
2	11570.000	39.03	14.60	35.31	28.65	46.97	54.00	7.03	Average
3	11570.000	39.03	14.60	35.31	45.48	63.80	74.00	10.20	Peak

Remarks: 1. Emission Level= Antenna Factor + Cable Loss + Reading - Amp Factor
 2. The emission levels that are 20dB below the official limit are not reported.

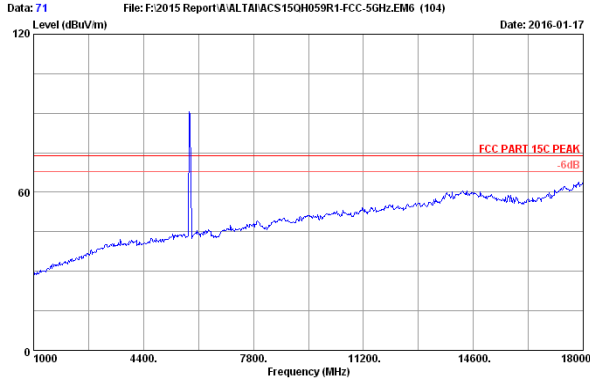

Site no. : 3m Chamber Data no. : 71
 Dis. / Ant. : 3m 2014 3115 9607-4877 Ant. pol. : HORIZONTAL
 Limit : FCC PART 15C PEAK
 Env. / Ins. : 23°C/54%
 Engineer : Leo-Li
 EUT : Altai A3w Indoor Dual-band 3x3 802.11ac WiFi AP
 Power rating : DC 56V From POE Input AC 120V/60Hz
 Test Mode : IEEE802.11ac VHT20 5825MHz Tx
 WA3311NAC-W

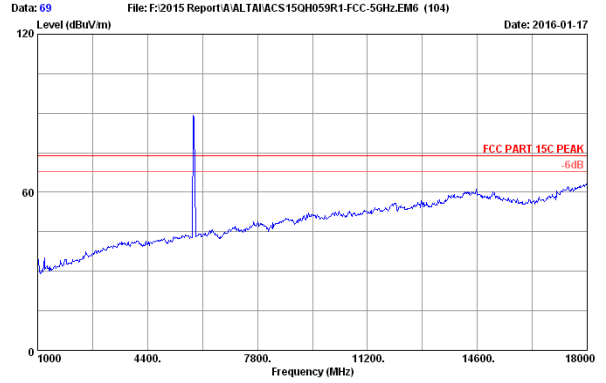

Site no. : 3m Chamber Data no. : 69
 Dis. / Ant. : 3m 2014 3115 9607-4877 Ant. pol. : VERTICAL
 Limit : FCC PART 15C PEAK
 Env. / Ins. : 23°C/54%
 Engineer : Leo-Li
 EUT : Altai A3w Indoor Dual-band 3x3 802.11ac WiFi AP
 Power rating : DC 56V From POE Input AC 120V/60Hz
 Test Mode : IEEE802.11ac VHT20 5825MHz Tx
 WA3311NAC-W

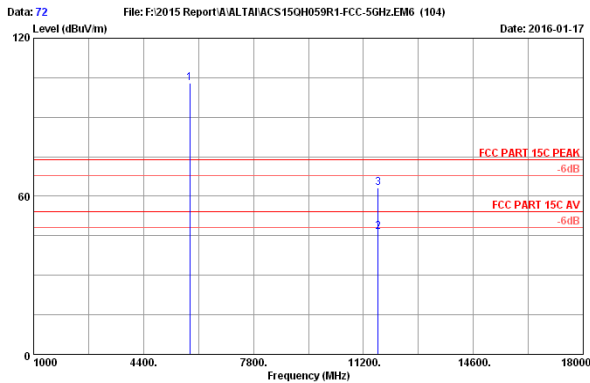

Site no. : 3m Chamber Data no. : 72
 Dis. / Ant. : 3m 2014 3115 9607-4877 Ant. pol. : HORIZONTAL
 Limit : FCC PART 15C PEAK
 Env. / Ins. : 23°C/54%
 Engineer : Leo-Li
 EUT : Altai A3w Indoor Dual-band 3x3 802.11ac WiFi AP
 Power rating : DC 56V From POE Input AC 120V/60Hz
 Test Mode : IEEE802.11ac VHT20 5825MHz Tx
 WA3311NAC-W

No.	Freq. (MHz)	Ant. Factor (dB/m)	Cable Loss (dB)	AMP factor (dB)	Reading (dBuV)	Emission Level (dBuV/m)	Limits (dBuV/m)	Margin (dB)	Remark
1	5825.000	34.43	9.93	35.08	93.68	102.96	74.00	-28.96	Peak
2	11650.000	39.06	14.66	35.29	28.19	46.82	54.00	7.38	Average
3	11650.000	39.06	14.66	35.29	44.75	63.18	74.00	10.82	Peak

Remarks: 1. Emission Level= Antenna Factor + Cable Loss + Reading - Amp Factor
 2. The emission levels that are 20dB below the official limit are not reported.

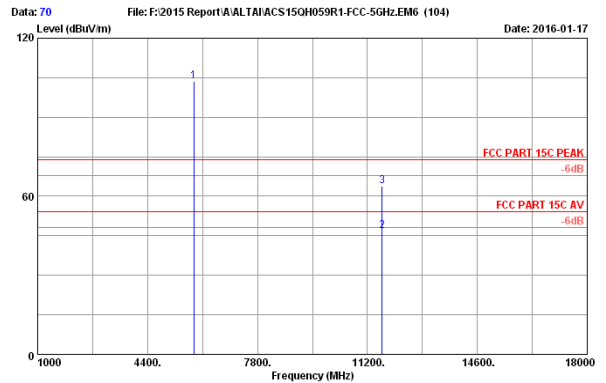

Site no. : 3m Chamber Data no. : 70
 Dis. / Ant. : 3m 2014 3115 9607-4877 Ant. pol. : VERTICAL
 Limit : FCC PART 15C PEAK
 Env. / Ins. : 23°C/54%
 Engineer : Leo-Li
 EUT : Altai A3w Indoor Dual-band 3x3 802.11ac WiFi AP
 Power rating : DC 56V From POE Input AC 120V/60Hz
 Test Mode : IEEE802.11ac VHT20 5825MHz Tx
 WA3311NAC-W

No.	Freq. (MHz)	Ant. Factor (dB/m)	Cable Loss (dB)	AMP factor (dB)	Reading (dBuV)	Emission Level (dBuV/m)	Limits (dBuV/m)	Margin (dB)	Remark
1	5825.000	34.43	9.93	35.08	94.23	103.51	74.00	-29.51	Peak
2	11650.000	39.06	14.66	35.29	28.36	46.79	54.00	7.21	Average
3	11650.000	39.06	14.66	35.29	45.29	63.72	74.00	10.28	Peak

Remarks: 1. Emission Level= Antenna Factor + Cable Loss + Reading - Amp Factor
 2. The emission levels that are 20dB below the official limit are not reported.

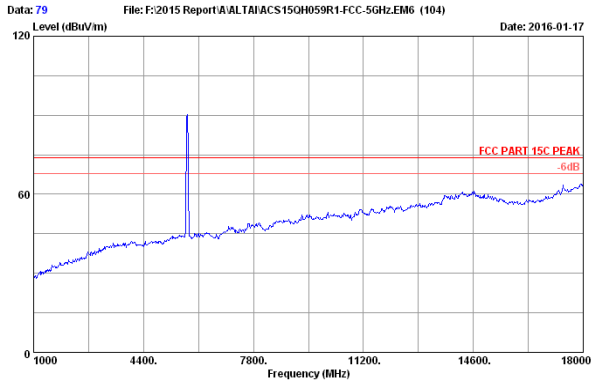

Site no. : 3m Chamber Data no. : 79
 Dis. / Ant. : 3m 2014 3115 9607-4877 Ant. pol. : HORIZONTAL
 Limit : FCC PART 15C PEAK
 Env. / Ins. : 23°C/54%
 Engineer : Leo-Li
 EUT : Altai A3w Indoor Dual-band 3x3 802.11ac WiFi AP
 Power rating : DC 56V From POE Input AC 120V/60Hz
 Test Mode : IEEE802.11ac VHT40 5755MHz Tx
 WA3311NAC-W

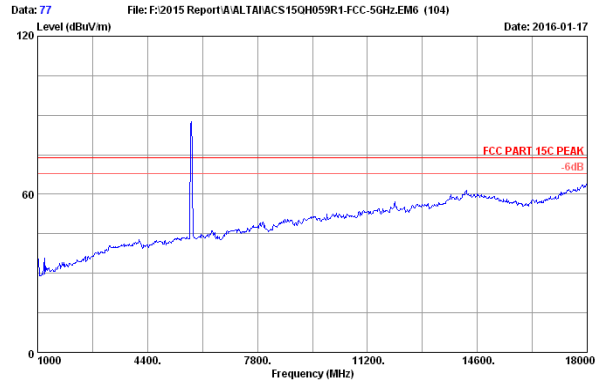

Site no. : 3m Chamber Data no. : 77
 Dis. / Ant. : 3m 2014 3115 9607-4877 Ant. pol. : VERTICAL
 Limit : FCC PART 15C PEAK
 Env. / Ins. : 23°C/54%
 Engineer : Leo-Li
 EUT : Altai A3w Indoor Dual-band 3x3 802.11ac WiFi AP
 Power rating : DC 56V From POE Input AC 120V/60Hz
 Test Mode : IEEE802.11ac VHT40 5755MHz Tx
 WA3311NAC-W

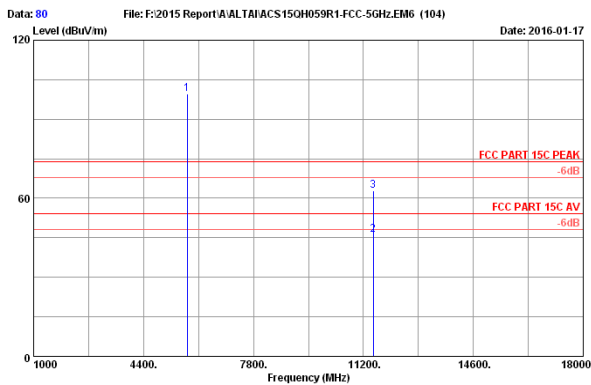

Site no. : 3m Chamber Data no. : 80
 Dis. / Ant. : 3m 2014 3115 9607-4877 Ant. pol. : HORIZONTAL
 Limit : FCC PART 15C PEAK
 Env. / Ins. : 23°C/54%
 Engineer : Leo-Li
 EUT : Altai A3w Indoor Dual-band 3x3 802.11ac WiFi AP
 Power rating : DC 56V From POE Input AC 120V/60Hz
 Test Mode : IEEE802.11ac VHT40 5755MHz Tx
 WA3311NAC-W

No.	Freq. (MHz)	Ant. Factor (dB/m)	Cable Loss (dB)	AMP factor (dB)	Reading (dBuV)	Emission Level (dBuV/m)	Limits (dBuV/m)	Margin (dB)	Remark
1	5755.000	34.40	9.91	35.11	90.58	99.78	74.00	-25.78	Peak
2	11510.000	39.00	14.56	35.33	27.81	46.04	54.00	7.96	Average
3	11510.000	39.00	14.56	35.33	44.76	62.99	74.00	11.01	Peak

Remarks: 1. Emission Level= Antenna Factor + Cable Loss + Reading - Amp Factor
 2. The emission levels that are 20dB below the official limit are not reported.

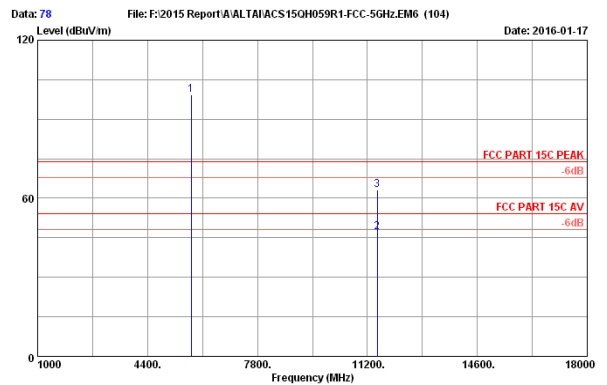

Site no. : 3m Chamber Data no. : 78
 Dis. / Ant. : 3m 2014 3115 9607-4877 Ant. pol. : VERTICAL
 Limit : FCC PART 15C PEAK
 Env. / Ins. : 23°C/54%
 Engineer : Leo-Li
 EUT : Altai A3w Indoor Dual-band 3x3 802.11ac WiFi AP
 Power rating : DC 56V From POE Input AC 120V/60Hz
 Test Mode : IEEE802.11ac VHT40 5755MHz Tx
 WA3311NAC-W

No.	Freq. (MHz)	Ant. Factor (dB/m)	Cable Loss (dB)	AMP factor (dB)	Reading (dBuV)	Emission Level (dBuV/m)	Limits (dBuV/m)	Margin (dB)	Remark
1	5755.000	34.40	9.91	35.11	89.98	99.18	74.00	-25.18	Peak
2	11510.000	39.00	14.56	35.33	28.84	47.07	54.00	6.93	Average
3	11510.000	39.00	14.56	35.33	44.79	63.02	74.00	10.98	Peak

Remarks: 1. Emission Level= Antenna Factor + Cable Loss + Reading - Amp Factor
 2. The emission levels that are 20dB below the official limit are not reported.

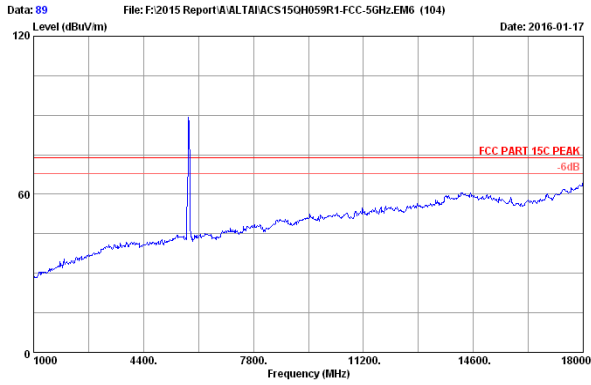

Site no. : 3m Chamber Data no. : 89
 Dis. / Ant. : 3m 2014 3115 9607-4877 Ant. pol. : HORIZONTAL
 Limit : FCC PART 15C PEAK
 Env. / Ins. : 23°C/54%
 Engineer : Leo-Li
 EUT : Altai A3w Indoor Dual-band 3x3 802.11ac WiFi AP
 Power rating : DC 56V From POE Input AC 120V/60Hz
 Test Mode : IEEE802.11ac VHT40 5795MHz Tx
 WA3311NAC-W

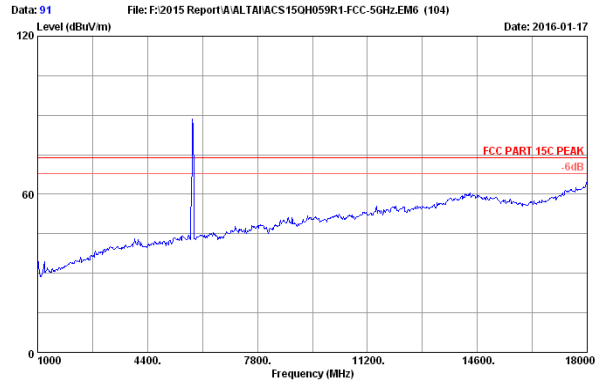

Site no. : 3m Chamber Data no. : 91
 Dis. / Ant. : 3m 2014 3115 9607-4877 Ant. pol. : VERTICAL
 Limit : FCC PART 15C PEAK
 Env. / Ins. : 23°C/54%
 Engineer : Leo-Li
 EUT : Altai A3w Indoor Dual-band 3x3 802.11ac WiFi AP
 Power rating : DC 56V From POE Input AC 120V/60Hz
 Test Mode : IEEE802.11ac VHT40 5795MHz Tx
 WA3311NAC-W

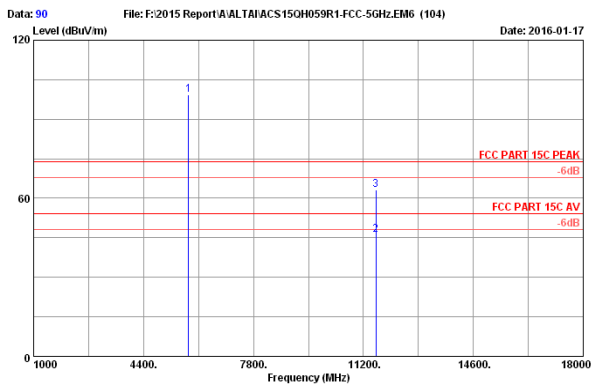

Site no. : 3m Chamber Data no. : 90
 Dis. / Ant. : 3m 2014 3115 9607-4877 Ant. pol. : HORIZONTAL
 Limit : FCC PART 15C PEAK
 Env. / Ins. : 23°C/54%
 Engineer : Leo-Li
 EUT : Altai A3w Indoor Dual-band 3x3 802.11ac WiFi AP
 Power rating : DC 56V From POE Input AC 120V/60Hz
 Test Mode : IEEE802.11ac VHT40 5795MHz Tx
 WA3311NAC-W

No.	Freq. (MHz)	Ant. Factor (dB/m)	Cable Loss (dB)	AMP factor (dB)	Reading (dBuV)	Emission Level (dBuV/m)	Limits (dBuV/m)	Margin (dB)	Remark
1	5795.000	34.42	9.92	35.09	90.12	99.37	74.00	-25.37	Peak
2	11590.000	39.04	14.61	35.30	27.65	46.00	54.00	8.00	Average
3	11590.000	39.04	14.61	35.30	44.87	63.22	74.00	10.78	Peak

Remarks: 1. Emission Level= Antenna Factor + Cable Loss + Reading - Amp Factor
 2. The emission levels that are 20dB below the official limit are not reported.

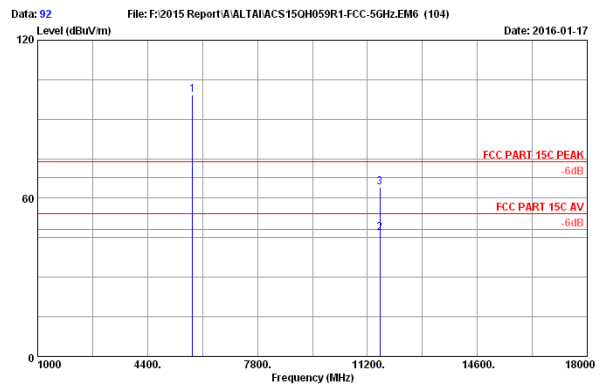

Site no. : 3m Chamber Data no. : 92
 Dis. / Ant. : 3m 2014 3115 9607-4877 Ant. pol. : VERTICAL
 Limit : FCC PART 15C PEAK
 Env. / Ins. : 23°C/54%
 Engineer : Leo-Li
 EUT : Altai A3w Indoor Dual-band 3x3 802.11ac WiFi AP
 Power rating : DC 56V From POE Input AC 120V/60Hz
 Test Mode : IEEE802.11ac VHT40 5795MHz Tx
 WA3311NAC-W

No.	Freq. (MHz)	Ant. Factor (dB/m)	Cable Loss (dB)	AMP factor (dB)	Reading (dBuV)	Emission Level (dBuV/m)	Limits (dBuV/m)	Margin (dB)	Remark
1	5795.000	34.42	9.92	35.09	89.96	99.21	74.00	-25.21	Peak
2	11590.000	39.04	14.61	35.30	28.53	46.88	54.00	7.12	Average
3	11590.000	39.04	14.61	35.30	45.76	64.11	74.00	9.89	Peak

Remarks: 1. Emission Level= Antenna Factor + Cable Loss + Reading - Amp Factor
 2. The emission levels that are 20dB below the official limit are not reported.

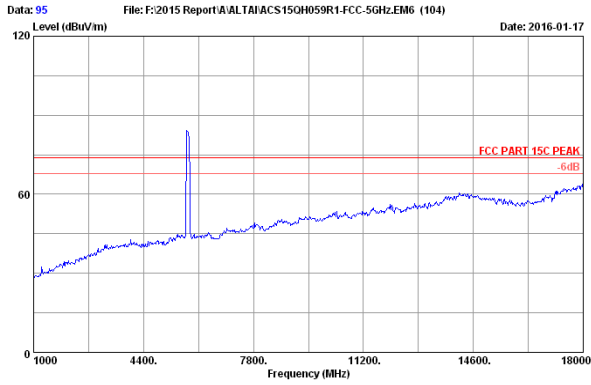

Site no. : 3m Chamber Data no. : 95
 Dis. / Ant. : 3m 2014 3115 9607-4877 Ant. pol. : HORIZONTAL
 Limit : FCC PART 15C PEAK
 Env. / Ins. : 23°C/54%
 Engineer : Leo-Li
 EUT : Altai A3w Indoor Dual-band 3x3 802.11ac WiFi AP
 Power rating : DC 56V From POE Input AC 120V/60Hz
 Test Mode : IEEE802.11ac VHT80 5775MHz Tx
 WA3311NAC-W

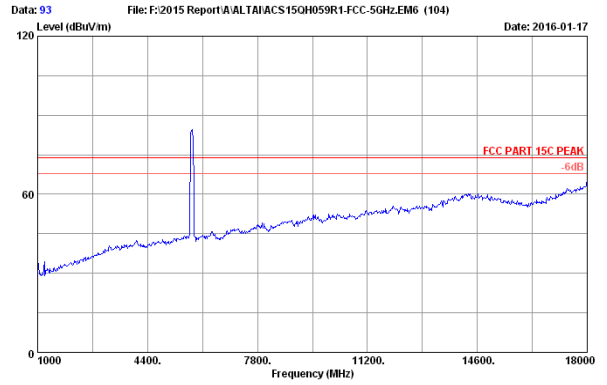

Site no. : 3m Chamber Data no. : 93
 Dis. / Ant. : 3m 2014 3115 9607-4877 Ant. pol. : VERTICAL
 Limit : FCC PART 15C PEAK
 Env. / Ins. : 23°C/54%
 Engineer : Leo-Li
 EUT : Altai A3w Indoor Dual-band 3x3 802.11ac WiFi AP
 Power rating : DC 56V From POE Input AC 120V/60Hz
 Test Mode : IEEE802.11ac VHT80 5775MHz Tx
 WA3311NAC-W

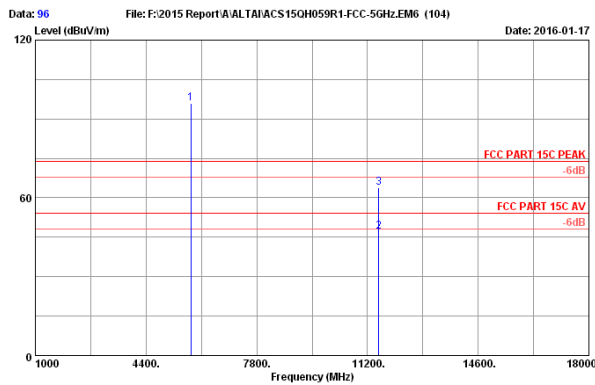

Site no. : 3m Chamber Data no. : 96
 Dis. / Ant. : 3m 2014 3115 9607-4877 Ant. pol. : HORIZONTAL
 Limit : FCC PART 15C PEAK
 Env. / Ins. : 23°C/54%
 Engineer : Leo-Li
 EUT : Altai A3w Indoor Dual-band 3x3 802.11ac WiFi AP
 Power rating : DC 56V From POE Input AC 120V/60Hz
 Test Mode : IEEE802.11ac VHT80 5775MHz Tx
 WA3311NAC-W

No.	Freq. (MHz)	Ant. Factor (dB/m)	Cable Loss (dB)	AMP factor (dB)	Reading (dBuV)	Emission Level (dBuV/m)	Limits (dBuV/m)	Margin (dB)	Remark
1	5775.000	34.41	9.91	35.10	86.75	95.97	74.00	-21.97	Peak
2	11550.000	39.02	14.58	35.31	28.75	47.04	54.00	6.96	Average
3	11550.000	39.02	14.58	35.31	45.39	63.66	74.00	10.32	Peak

Remarks: 1. Emission Level= Antenna Factor + Cable Loss + Reading - Amp Factor
 2. The emission levels that are 20dB below the official limit are not reported.

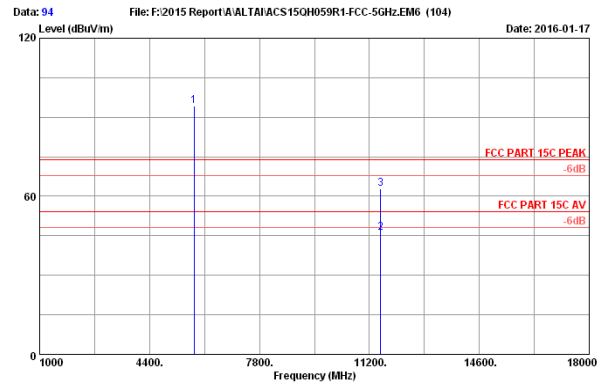

Site no. : 3m Chamber Data no. : 94
 Dis. / Ant. : 3m 2014 3115 9607-4877 Ant. pol. : VERTICAL
 Limit : FCC PART 15C PEAK
 Env. / Ins. : 23°C/54%
 Engineer : Leo-Li
 EUT : Altai A3w Indoor Dual-band 3x3 802.11ac WiFi AP
 Power rating : DC 56V From POE Input AC 120V/60Hz
 Test Mode : IEEE802.11ac VHT80 5775MHz Tx
 WA3311NAC-W

No.	Freq. (MHz)	Ant. Factor (dB/m)	Cable Loss (dB)	AMP factor (dB)	Reading (dBuV)	Emission Level (dBuV/m)	Limits (dBuV/m)	Margin (dB)	Remark
1	5775.000	34.41	9.91	35.10	85.02	94.24	74.00	-20.24	Peak
2	11550.000	39.02	14.58	35.31	27.83	46.12	54.00	7.88	Average
3	11550.000	39.02	14.58	35.31	44.67	62.96	74.00	11.04	Peak

Remarks: 1. Emission Level= Antenna Factor + Cable Loss + Reading - Amp Factor
 2. The emission levels that are 20dB below the official limit are not reported.

5. BAND EDGE COMPLIANCE TEST

5.1. Test Equipment

Item	Equipment	Manufacturer	Model No.	Serial No.	Last Cal.	Cal. Interval
1.	Spectrum	Agilent	E4446A	US44300459	Apr.28,15	1 Year
2.	Amp	HP	8449B	3008A02495	Apr.28,15	1 Year
3.	Horn Antenna	ETS	3115	9510-4877	Oct.15,15	1 Year
4.	HF Cable	Hubersuhner	Sucoflex104	274094/4	Apr.28,15	1 Year

5.2. Limit

For transmitters operating in the band 5150-5250 MHz, all emissions outside the band 5150-5350 MHz shall not exceed -27 dBm/MHz e.i.r.p.

For devices with both operating frequencies and channel bandwidths contained within the band 5250-5350 MHz,

All emissions outside the band 5250-5350 MHz shall not exceed -27 dBm/MHz e.i.r.p.

For transmitters operating in the band 5470-5725MHz, Emissions outside the band 5470-5725 MHz shall not exceed -27 dBm/MHz e.i.r.p.

For the band 5725-5850 MHz, emissions at frequencies from the band edges to 10 MHz above or below the band edges shall not exceed -17 dBm/MHz e.i.r.p.

For emissions at frequencies more than 10 MHz above or below the band edges, the emissions power shall not exceed -27 dBm/MHz.

5.3. Test Produce

1. The EUT is placed on a turntable, which is 0.8m above the ground plane and worked at highest radiated power.
2. The turntable was rotated for 360 degrees to determine the position of maximum emission level.
3. EUT is set 3m away from the receiving antenna, which is varied from 1m to 4m to find out the highest emission.
4. Set the spectrum analyzer in the following setting in order to capture the lower and upper band-edges of the emission:
 - (a) PEAK: RBW=1MHz; VBW=3MHz; Sweep=AUTO
 - (b) AVERAGE: RBW=1MHz; VBW=10Hz; Sweep=AUTO
5. Per KDB789033 clause H 2)d).if the test distance is 3m, the EIRP(dBm)=E(dBuv/m)-95.2
Get the final compare with limit.

5.4. Test Results

Pass (The testing data was attached in the next pages.)

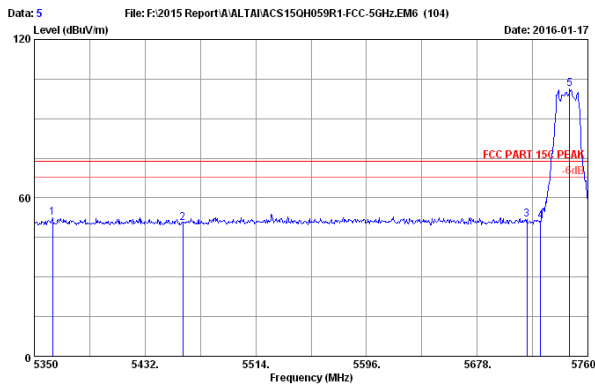

Site no. : 3m Chamber Data no. : 5
 Dis. / Ant. : 3m 2015 3115-4877 Ant. pol. : HORIZONTAL
 Limit : FCC PART 15C PEAK
 Env. / Ins. : 23°C/54%
 Engineer : Leo-Li
 EUT : Altai A3w Indoor Dual-band 3x3 802.11ac WiFi AP
 Power rating : DC 56V From POE Input AC 120V/60Hz
 Test Mode : IEEE802.11a 5745MHz Tx
 WA3311NAC-W

No.	Freq. (MHz)	Ant. Factor (dB/m)	Cable Loss (dB)	AMP factor (dB)	Reading (dBuV)	Emission Level (dBuV/m)	Limits (dBuV/m)	Margin (dB)	Remark
1	5363.530	34.15	9.72	35.28	43.96	52.55	74.00	21.45	Peak
2	5459.880	34.33	9.76	35.25	41.57	50.41	74.00	23.59	Peak
3	5715.000	33.42	9.88	35.12	43.46	51.64	74.00	22.36	Peak
4	5725.000	33.42	9.89	35.12	43.03	51.22	74.00	22.78	Peak
5	5746.470	33.45	9.90	35.11	92.88	101.12	74.00	-27.12	Peak

Remarks: 1. Emission Level= Antenna Factor + Cable Loss + Reading - Amp Factor
 2. The emission levels that are 20dB below the official limit are not reported.

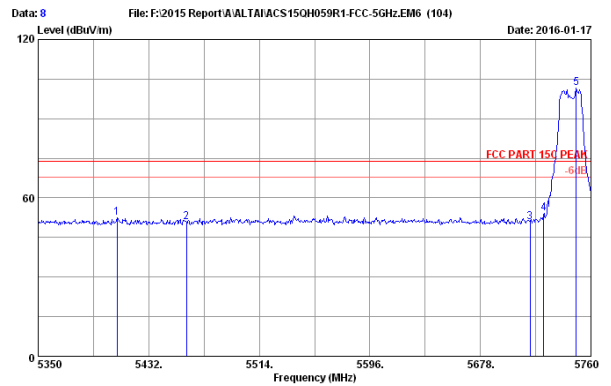

Site no. : 3m Chamber Data no. : 8
 Dis. / Ant. : 3m 2015 3115-4877 Ant. pol. : VERTICAL
 Limit : FCC PART 15C PEAK
 Env. / Ins. : 23°C/54%
 Engineer : Leo-Li
 EUT : Altai A3w Indoor Dual-band 3x3 802.11ac WiFi AP
 Power rating : DC 56V From POE Input AC 120V/60Hz
 Test Mode : IEEE802.11a 5745MHz Tx
 WA3311NAC-W

No.	Freq. (MHz)	Ant. Factor (dB/m)	Cable Loss (dB)	AMP factor (dB)	Reading (dBuV)	Emission Level (dBuV/m)	Limits (dBuV/m)	Margin (dB)	Remark
1	5408.630	34.24	9.74	35.27	43.76	52.47	74.00	21.53	Peak
2	5460.000	34.33	9.76	35.25	42.00	50.84	74.00	23.16	Peak
3	5715.000	33.42	9.88	35.12	42.69	50.87	74.00	23.13	Peak
4	5725.000	33.42	9.89	35.12	45.88	54.07	74.00	19.93	Peak
5	5748.930	33.45	9.90	35.11	93.34	101.58	74.00	-27.58	Peak

Remarks: 1. Emission Level= Antenna Factor + Cable Loss + Reading - Amp Factor
 2. The emission levels that are 20dB below the official limit are not reported.

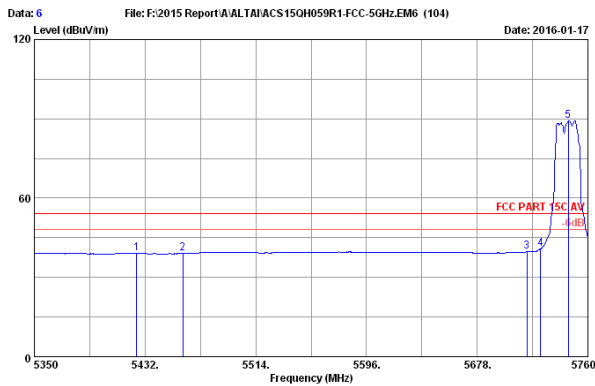

Site no. : 3m Chamber Data no. : 6
 Dis. / Ant. : 3m 2015 3115-4877 Ant. pol. : HORIZONTAL
 Limit : FCC PART 15C AV
 Env. / Ins. : 23°C/54%
 Engineer : Leo-Li
 EUT : Altai A3w Indoor Dual-band 3x3 802.11ac WiFi AP
 Power rating : DC 56V From POE Input AC 120V/60Hz
 Test Mode : IEEE802.11a 5745MHz Tx
 WA3311NAC-W

No.	Freq. (MHz)	Ant. Factor (dB/m)	Cable Loss (dB)	AMP factor (dB)	Reading (dBuV)	Emission Level (dBuV/m)	Limits (dBuV/m)	Margin (dB)	Remark
1	5425.850	34.27	9.74	35.26	30.37	39.12	54.00	14.88	Average
2	5460.000	33.26	9.76	35.25	31.21	38.98	54.00	15.02	Average
3	5715.000	33.42	9.88	35.12	31.46	39.64	54.00	14.36	Average
4	5725.000	33.42	9.89	35.12	32.72	40.91	54.00	13.09	Average
5	5745.650	33.45	9.90	35.11	81.07	89.31	54.00	-35.31	Average

Remarks: 1. Emission Level= Antenna Factor + Cable Loss + Reading - Amp Factor
 2. The emission levels that are 20dB below the official limit are not reported.

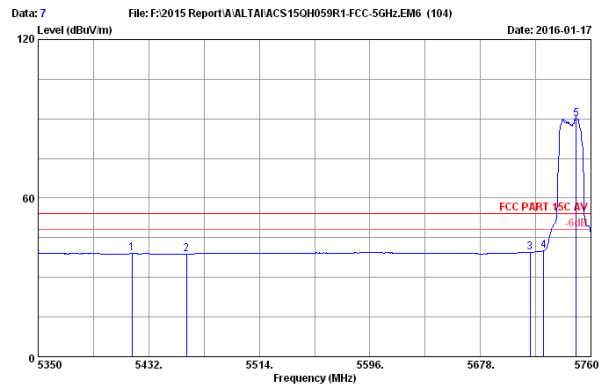

Site no. : 3m Chamber Data no. : 7
 Dis. / Ant. : 3m 2015 3115-4877 Ant. pol. : VERTICAL
 Limit : FCC PART 15C AV
 Env. / Ins. : 23°C/54%
 Engineer : Leo-Li
 EUT : Altai A3w Indoor Dual-band 3x3 802.11ac WiFi AP
 Power rating : DC 56V From POE Input AC 120V/60Hz
 Test Mode : IEEE802.11a 5745MHz Tx
 WA3311NAC-W

No.	Freq. (MHz)	Ant. Factor (dB/m)	Cable Loss (dB)	AMP factor (dB)	Reading (dBuV)	Emission Level (dBuV/m)	Limits (dBuV/m)	Margin (dB)	Remark
1	5419.700	34.26	9.74	35.26	30.33	39.07	54.00	14.93	Average
2	5460.000	33.26	9.76	35.25	31.10	38.87	54.00	15.13	Average
3	5715.000	33.42	9.88	35.12	31.23	39.41	54.00	14.59	Average
4	5725.000	33.42	9.89	35.12	31.95	40.14	54.00	13.86	Average
5	5748.930	33.45	9.90	35.11	81.75	89.99	54.00	-35.99	Average

Remarks: 1. Emission Level= Antenna Factor + Cable Loss + Reading - Amp Factor
 2. The emission levels that are 20dB below the official limit are not reported.

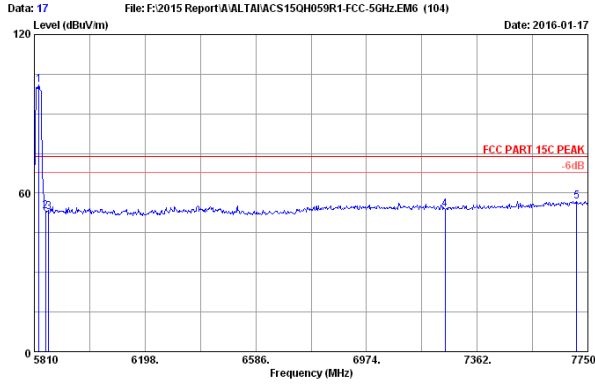

Data: 17 File: F:\2015 Report\A\ALTAIACS15QH059R1-FCC-5GHz.EM6 (104) Date: 2016-01-17

Site no. : 3m Chamber Data no. : 17
 Dis. / Ant. : 3m 2014 3115 9607-4877 Ant. pol. : HORIZONTAL
 Limit : FCC PART 15C PEAK
 Env. / Ins. : 23°C/54%
 Engineer : Leo-Li
 EUT : Altai A3w Indoor Dual-band 3x3 802.11ac WiFi AP
 Power rating : DC 56W From POE Input AC 120V/60Hz
 Test Mode : IEEE802.11a 5825MHz Tx
 WA3311NAC-U

No.	Freq. (MHz)	Ant. Factor (dB/m)	Cable Loss (dB)	AMP factor (dB)	Reading (dBuV)	Emission Level (dBuV/m)	Limits (dBuV/m)	Margin (dB)	Remark
1	5825.520	34.43	9.94	35.08	91.63	100.92	74.00	-26.92	Peak
2	5850.000	34.44	9.95	35.07	43.67	52.99	74.00	21.01	Peak
3	5860.000	34.45	9.95	35.07	43.53	52.86	74.00	21.14	Peak
4	7250.000	35.91	10.74	35.50	42.82	53.97	74.00	20.03	Peak
5	7711.200	36.63	11.18	35.68	44.74	56.87	74.00	17.13	Peak

Remarks: 1. Emission Level= Antenna Factor + Cable Loss + Reading - Amp Factor
 2. The emission levels that are 20dB below the official limit are not reported.

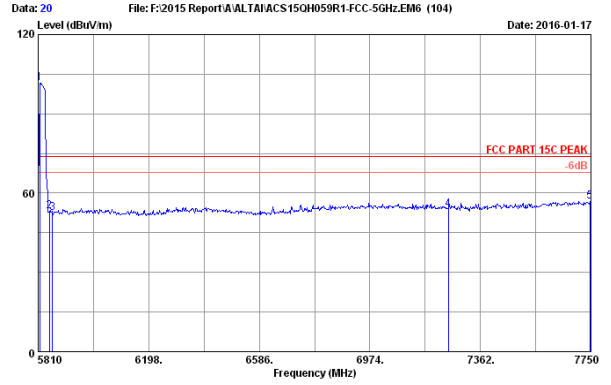

Data: 20 File: F:\2015 Report\A\ALTAIACS15QH059R1-FCC-5GHz.EM6 (104) Date: 2016-01-17

Site no. : 3m Chamber Data no. : 20
 Dis. / Ant. : 3m 2014 3115 9607-4877 Ant. pol. : VERTICAL
 Limit : FCC PART 15C PEAK
 Env. / Ins. : 23°C/54%
 Engineer : Leo-Li
 EUT : Altai A3w Indoor Dual-band 3x3 802.11ac WiFi AP
 Power rating : DC 56W From POE Input AC 120V/60Hz
 Test Mode : IEEE802.11a 5825MHz Tx
 WA3311NAC-U

No.	Freq. (MHz)	Ant. Factor (dB/m)	Cable Loss (dB)	AMP factor (dB)	Reading (dBuV)	Emission Level (dBuV/m)	Limits (dBuV/m)	Margin (dB)	Remark
1	5815.820	34.43	9.93	35.08	92.94	101.62	74.00	-27.62	Peak
2	5850.000	34.44	9.95	35.07	43.79	53.11	74.00	20.89	Peak
3	5860.000	34.45	9.95	35.07	43.13	52.46	74.00	21.54	Peak
4	7250.000	35.91	10.74	35.50	42.76	53.91	74.00	20.09	Peak
5	7746.120	36.65	11.22	35.70	44.58	56.75	74.00	17.25	Peak

Remarks: 1. Emission Level= Antenna Factor + Cable Loss + Reading - Amp Factor
 2. The emission levels that are 20dB below the official limit are not reported.

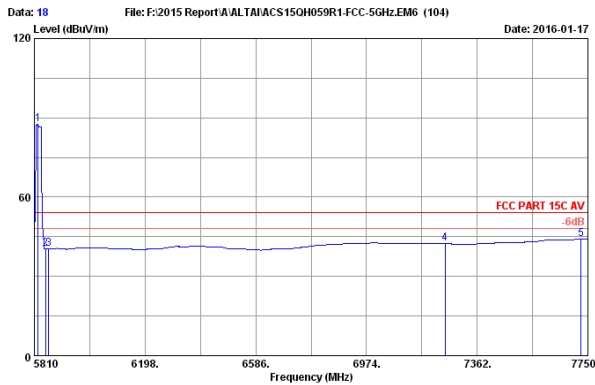

Data: 18 File: F:\2015 Report\A\ALTAIACS15QH059R1-FCC-5GHz.EM6 (104) Date: 2016-01-17

Site no. : 3m Chamber Data no. : 18
 Dis. / Ant. : 3m 2014 3115 9607-4877 Ant. pol. : HORIZONTAL
 Limit : FCC PART 15C AV
 Env. / Ins. : 23°C/54%
 Engineer : Leo-Li
 EUT : Altai A3w Indoor Dual-band 3x3 802.11ac WiFi AP
 Power rating : DC 56W From POE Input AC 120V/60Hz
 Test Mode : IEEE802.11a 5825MHz Tx
 WA3311NAC-U

No.	Freq. (MHz)	Ant. Factor (dB/m)	Cable Loss (dB)	AMP factor (dB)	Reading (dBuV)	Emission Level (dBuV/m)	Limits (dBuV/m)	Margin (dB)	Remark
1	5823.580	34.43	9.93	35.08	78.43	87.71	54.00	-33.71	Average
2	5850.000	34.44	9.95	35.07	31.19	40.51	54.00	13.49	Average
3	5860.000	34.45	9.95	35.07	31.11	40.44	54.00	13.56	Average
4	7250.000	35.91	10.74	35.50	31.22	42.37	54.00	11.63	Average
5	7726.720	36.64	11.20	35.69	31.89	44.04	54.00	9.96	Average

Remarks: 1. Emission Level= Antenna Factor + Cable Loss + Reading - Amp Factor
 2. The emission levels that are 20dB below the official limit are not reported.

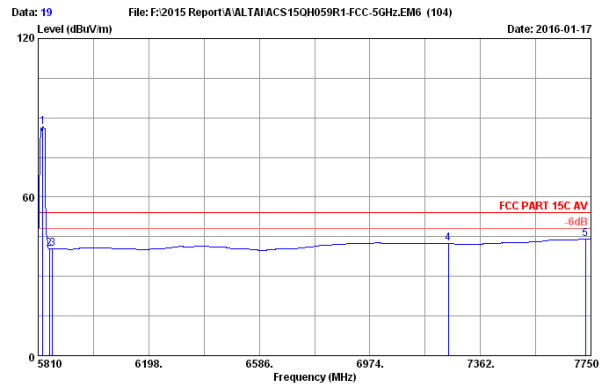

Data: 19 File: F:\2015 Report\A\ALTAIACS15QH059R1-FCC-5GHz.EM6 (104) Date: 2016-01-17

Site no. : 3m Chamber Data no. : 19
 Dis. / Ant. : 3m 2014 3115 9607-4877 Ant. pol. : VERTICAL
 Limit : FCC PART 15C AV
 Env. / Ins. : 23°C/54%
 Engineer : Leo-Li
 EUT : Altai A3w Indoor Dual-band 3x3 802.11ac WiFi AP
 Power rating : DC 56W From POE Input AC 120V/60Hz
 Test Mode : IEEE802.11a 5825MHz Tx
 WA3311NAC-U

No.	Freq. (MHz)	Ant. Factor (dB/m)	Cable Loss (dB)	AMP factor (dB)	Reading (dBuV)	Emission Level (dBuV/m)	Limits (dBuV/m)	Margin (dB)	Remark
1	5825.520	34.43	9.94	35.08	77.45	86.74	54.00	-32.74	Average
2	5850.000	34.44	9.95	35.07	30.97	40.29	54.00	13.71	Average
3	5860.000	34.45	9.95	35.07	30.98	40.31	54.00	13.69	Average
4	7250.000	35.91	10.74	35.50	31.18	42.33	54.00	11.67	Average
5	7730.600	36.64	11.22	35.69	31.88	44.05	54.00	9.95	Average

Remarks: 1. Emission Level= Antenna Factor + Cable Loss + Reading - Amp Factor
 2. The emission levels that are 20dB below the official limit are not reported.

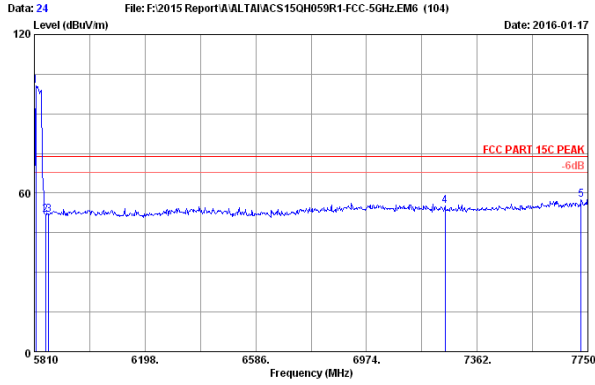

Data: 24 File: F:\2015 Report\A\ALTAIACS15QH059R1-FCC-5GHz.EM6 (104) Date: 2016-01-17

Site no. : 3m Chamber Data no. : 24
 Dis. / Ant. : 3m 2014 3115 9607-4877 Ant. pol. : HORIZONTAL
 Limit : FCC PART 15C PEAK
 Env. / Ins. : 23°C/54%
 Engineer : Leo-Li
 EUT : Altai A3w Indoor Dual-band 3x3 802.11ac WiFi AP
 Power rating : DC 56V From POE Input AC 120V/60Hz
 Test Mode : IEEE802.11nHT20 5825MHz Tx
 WA3311NAC-W

No.	Freq. (MHz)	Ant. Factor (dB/m)	Cable Loss (dB)	AMP factor (dB)	Reading (dBuV)	Emission Level (dBuV/m)	Limits (dBuV/m)	Margin (dB)	Remark
1	5815.820	34.43	9.93	35.08	91.33	100.61	74.00	-26.61	Peak
2	5850.000	34.44	9.95	35.07	42.55	51.87	74.00	22.13	Peak
3	5860.000	34.45	9.95	35.07	42.57	51.90	74.00	22.10	Peak
4	7250.000	35.91	10.74	35.50	43.95	55.10	74.00	18.90	Peak
5	7726.720	36.64	11.20	35.69	45.40	57.55	74.00	16.45	Peak

Remarks: 1. Emission Level= Antenna Factor + Cable Loss + Reading - Amp Factor
 2. The emission levels that are 20dB below the official limit are not reported.

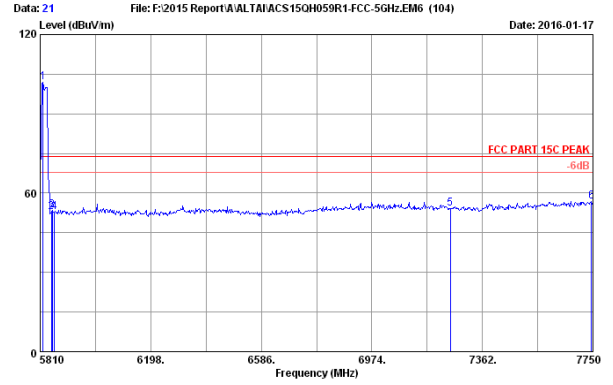

Data: 21 File: F:\2015 Report\A\ALTAIACS15QH059R1-FCC-5GHz.EM6 (104) Date: 2016-01-17

Site no. : 3m Chamber Data no. : 21
 Dis. / Ant. : 3m 2014 3115 9607-4877 Ant. pol. : VERTICAL
 Limit : FCC PART 15C PEAK
 Env. / Ins. : 23°C/54%
 Engineer : Leo-Li
 EUT : Altai A3w Indoor Dual-band 3x3 802.11ac WiFi AP
 Power rating : DC 56V From POE Input AC 120V/60Hz
 Test Mode : IEEE802.11nHT20 5825MHz Tx
 WA3311NAC-W

No.	Freq. (MHz)	Ant. Factor (dB/m)	Cable Loss (dB)	AMP factor (dB)	Reading (dBuV)	Emission Level (dBuV/m)	Limits (dBuV/m)	Margin (dB)	Remark
1	5819.700	34.43	9.93	35.08	92.60	101.88	74.00	-27.88	Peak
2	5850.000	34.44	9.95	35.07	43.58	52.90	74.00	21.10	Peak
3	5852.680	34.44	9.95	35.07	44.15	53.47	74.00	20.53	Peak
4	5860.000	34.45	9.95	35.07	43.62	52.95	74.00	21.05	Peak
5	7250.000	35.91	10.74	35.50	42.84	53.99	74.00	20.01	Peak
6	7744.180	36.65	11.22	35.70	44.51	56.68	74.00	17.32	Peak

Remarks: 1. Emission Level= Antenna Factor + Cable Loss + Reading - Amp Factor
 2. The emission levels that are 20dB below the official limit are not reported.

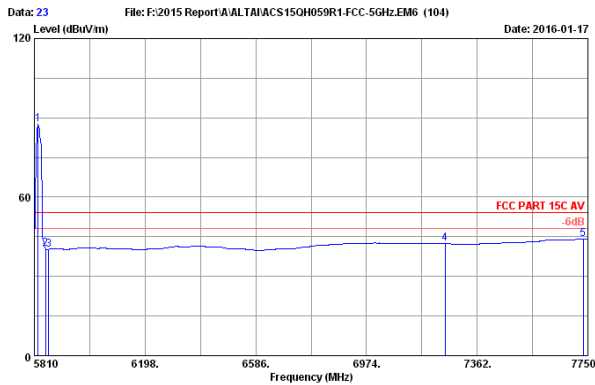

Data: 23 File: F:\2015 Report\A\ALTAIACS15QH059R1-FCC-5GHz.EM6 (104) Date: 2016-01-17

Site no. : 3m Chamber Data no. : 23
 Dis. / Ant. : 3m 2014 3115 9607-4877 Ant. pol. : HORIZONTAL
 Limit : FCC PART 15C AV
 Env. / Ins. : 23°C/54%
 Engineer : Leo-Li
 EUT : Altai A3w Indoor Dual-band 3x3 802.11ac WiFi AP
 Power rating : DC 56V From POE Input AC 120V/60Hz
 Test Mode : IEEE802.11nHT20 5825MHz Tx
 WA3311NAC-W

No.	Freq. (MHz)	Ant. Factor (dB/m)	Cable Loss (dB)	AMP factor (dB)	Reading (dBuV)	Emission Level (dBuV/m)	Limits (dBuV/m)	Margin (dB)	Remark
1	5823.580	34.43	9.93	35.08	78.43	87.71	54.00	-33.71	Average
2	5850.000	34.44	9.95	35.07	31.04	40.36	54.00	13.64	Average
3	5860.000	34.45	9.95	35.07	30.94	40.27	54.00	13.73	Average
4	7250.000	35.91	10.74	35.50	31.17	42.32	54.00	11.68	Average
5	7734.480	36.64	11.22	35.69	31.86	44.03	54.00	9.97	Average

Remarks: 1. Emission Level= Antenna Factor + Cable Loss + Reading - Amp Factor
 2. The emission levels that are 20dB below the official limit are not reported.

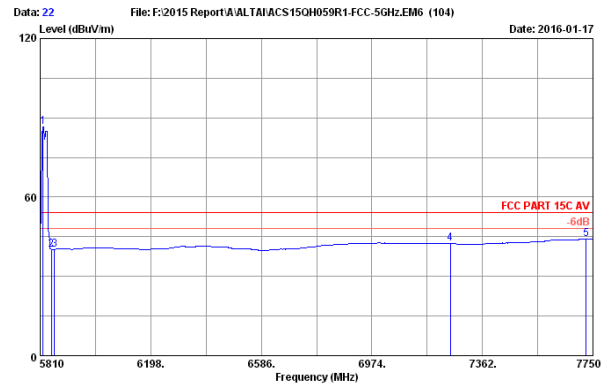

Data: 22 File: F:\2015 Report\A\ALTAIACS15QH059R1-FCC-5GHz.EM6 (104) Date: 2016-01-17

Site no. : 3m Chamber Data no. : 22
 Dis. / Ant. : 3m 2014 3115 9607-4877 Ant. pol. : VERTICAL
 Limit : FCC PART 15C AV
 Env. / Ins. : 23°C/54%
 Engineer : Leo-Li
 EUT : Altai A3w Indoor Dual-band 3x3 802.11ac WiFi AP
 Power rating : DC 56V From POE Input AC 120V/60Hz
 Test Mode : IEEE802.11nHT20 5825MHz Tx
 WA3311NAC-W

No.	Freq. (MHz)	Ant. Factor (dB/m)	Cable Loss (dB)	AMP factor (dB)	Reading (dBuV)	Emission Level (dBuV/m)	Limits (dBuV/m)	Margin (dB)	Remark
1	5819.700	34.43	9.93	35.08	77.41	86.69	54.00	-32.69	Average
2	5850.000	34.44	9.95	35.07	30.90	40.22	54.00	13.78	Average
3	5860.000	34.45	9.95	35.07	30.90	40.23	54.00	13.77	Average
4	7250.000	35.91	10.74	35.50	31.17	42.32	54.00	11.68	Average
5	7726.720	36.64	11.20	35.69	31.88	44.03	54.00	9.97	Average

Remarks: 1. Emission Level= Antenna Factor + Cable Loss + Reading - Amp Factor
 2. The emission levels that are 20dB below the official limit are not reported.

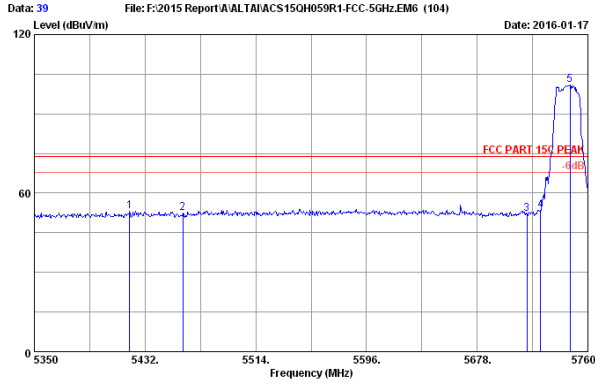

Site no. : 3m Chamber Data no. : 39
 Dis. / Ant. : 3m 2014 3115 9607-4877 Ant. pol. : HORIZONTAL
 Limit : FCC PART 15C PEAK
 Env. / Ins. : 23°C/54%
 Engineer : Leo-Li
 EUT : Altai A3w Indoor Dual-band 3x3 802.11ac WiFi AP
 Power rating : DC 56V From POE Input AC 120V/60Hz
 Test Mode : IEEE802.11nHT20 5745MHz Tx
 WA3311NAC-W

No.	Freq. (MHz)	Ant. Factor (dB/m)	Cable Loss (dB)	AMP factor (dB)	Reading (dBuV)	Emission Level (dBuV/m)	Limits (dBuV/m)	Margin (dB)	Remark
1	5420.520	34.16	9.76	35.26	44.44	53.08	74.00	20.92	Peak
2	5460.000	34.23	9.76	35.25	43.57	52.31	74.00	21.69	Peak
3	5715.000	34.39	9.88	35.12	42.86	52.01	74.00	21.99	Peak
4	5725.000	34.39	9.89	35.12	44.48	53.64	74.00	20.36	Peak
5	5746.880	34.40	9.90	35.11	91.59	100.78	74.00	-26.78	Peak

Remarks: 1. Emission Level= Antenna Factor + Cable Loss + Reading - Amp Factor
 2. The emission levels that are 20dB below the official limit are not reported.

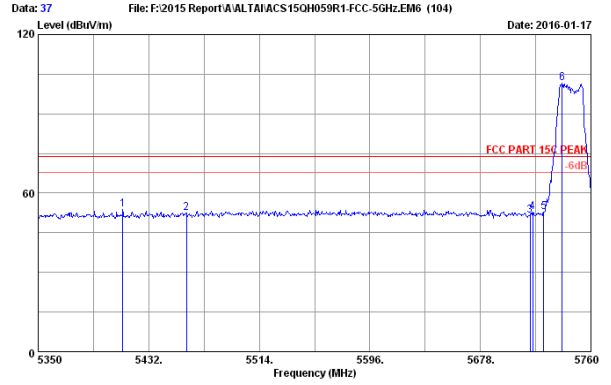

Site no. : 3m Chamber Data no. : 37
 Dis. / Ant. : 3m 2014 3115 9607-4877 Ant. pol. : VERTICAL
 Limit : FCC PART 15C PEAK
 Env. / Ins. : 23°C/54%
 Engineer : Leo-Li
 EUT : Altai A3w Indoor Dual-band 3x3 802.11ac WiFi AP
 Power rating : DC 56V From POE Input AC 120V/60Hz
 Test Mode : IEEE802.11nHT20 5745MHz Tx
 WA3311NAC-W

No.	Freq. (MHz)	Ant. Factor (dB/m)	Cable Loss (dB)	AMP factor (dB)	Reading (dBuV)	Emission Level (dBuV/m)	Limits (dBuV/m)	Margin (dB)	Remark
1	5412.730	34.15	9.74	35.26	45.94	53.97	74.00	20.03	Peak
2	5460.000	34.23	9.76	35.25	43.88	52.62	74.00	21.38	Peak
3	5715.000	34.39	9.88	35.12	42.44	51.59	74.00	22.41	Peak
4	5716.950	34.39	9.88	35.12	43.52	52.67	74.00	21.33	Peak
5	5725.000	34.39	9.89	35.12	43.63	52.79	74.00	21.21	Peak
6	5738.680	34.40	9.90	35.11	92.32	101.51	74.00	-27.51	Peak

Remarks: 1. Emission Level= Antenna Factor + Cable Loss + Reading - Amp Factor
 2. The emission levels that are 20dB below the official limit are not reported.

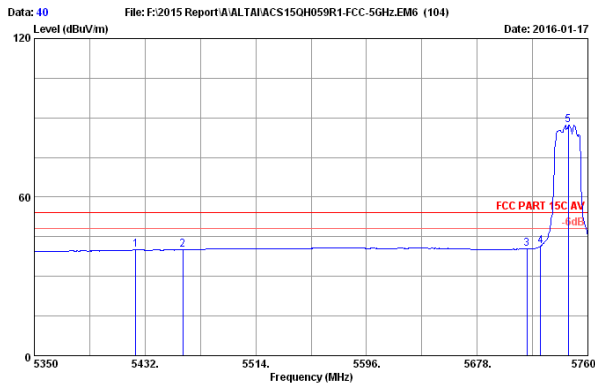

Site no. : 3m Chamber Data no. : 40
 Dis. / Ant. : 3m 2014 3115 9607-4877 Ant. pol. : HORIZONTAL
 Limit : FCC PART 15C AV
 Env. / Ins. : 23°C/54%
 Engineer : Leo-Li
 EUT : Altai A3w Indoor Dual-band 3x3 802.11ac WiFi AP
 Power rating : DC 56V From POE Input AC 120V/60Hz
 Test Mode : IEEE802.11nHT20 5745MHz Tx
 WA3311NAC-W

No.	Freq. (MHz)	Ant. Factor (dB/m)	Cable Loss (dB)	AMP factor (dB)	Reading (dBuV)	Emission Level (dBuV/m)	Limits (dBuV/m)	Margin (dB)	Remark
1	5425.030	34.17	9.74	35.26	31.41	40.06	54.00	13.94	Average
2	5460.000	34.23	9.76	35.25	31.26	40.00	54.00	14.00	Average
3	5715.000	34.39	9.88	35.12	31.19	40.34	54.00	13.66	Average
4	5725.000	34.39	9.89	35.12	32.34	41.50	54.00	12.50	Average
5	5745.650	34.40	9.90	35.11	78.21	87.40	54.00	-33.40	Average

Remarks: 1. Emission Level= Antenna Factor + Cable Loss + Reading - Amp Factor
 2. The emission levels that are 20dB below the official limit are not reported.

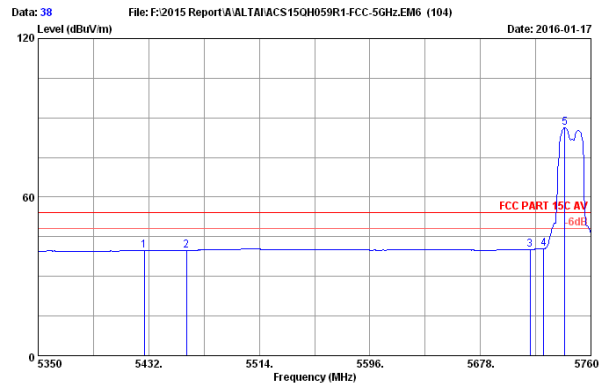

Site no. : 3m Chamber Data no. : 38
 Dis. / Ant. : 3m 2014 3115 9607-4877 Ant. pol. : VERTICAL
 Limit : FCC PART 15C AV
 Env. / Ins. : 23°C/54%
 Engineer : Leo-Li
 EUT : Altai A3w Indoor Dual-band 3x3 802.11ac WiFi AP
 Power rating : DC 56V From POE Input AC 120V/60Hz
 Test Mode : IEEE802.11nHT20 5745MHz Tx
 WA3311NAC-W

No.	Freq. (MHz)	Ant. Factor (dB/m)	Cable Loss (dB)	AMP factor (dB)	Reading (dBuV)	Emission Level (dBuV/m)	Limits (dBuV/m)	Margin (dB)	Remark
1	5428.720	34.18	9.74	35.26	31.28	39.94	54.00	14.06	Average
2	5460.000	34.23	9.76	35.25	31.09	39.83	54.00	14.17	Average
3	5715.000	34.39	9.88	35.12	30.96	40.11	54.00	13.89	Average
4	5725.000	34.39	9.89	35.12	31.34	40.50	54.00	13.50	Average
5	5740.730	34.40	9.90	35.11	77.05	86.24	54.00	-32.24	Average

Remarks: 1. Emission Level= Antenna Factor + Cable Loss + Reading - Amp Factor
 2. The emission levels that are 20dB below the official limit are not reported.

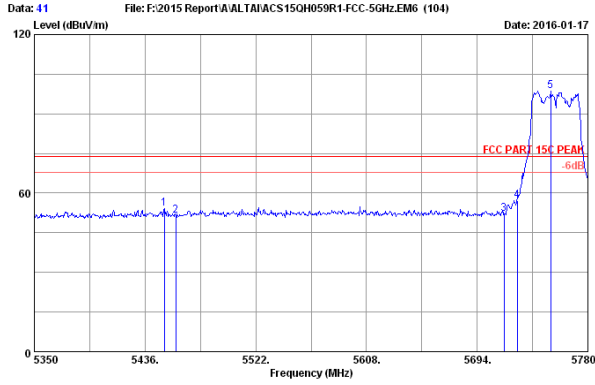

Site no. : 3m Chamber Data no. : 41
 Dis. / Ant. : 3m 2014 3115 9607-4877 Ant. pol. : HORIZONTAL
 Limit : FCC PART 15C PEAK
 Env. / Ins. : 23°C/54%
 Engineer : Leo-L1
 EUT : Altai A3w Indoor Dual-band 3x3 802.11ac WiFi AP
 Power rating : DC 56V From POE Input AC 120V/60Hz
 Test Mode : IEEE802.11nHT40 5755MHz Tx
 WA3311NAC-W

No.	Freq. (MHz)	Ant. Factor (dB/m)	Cable Loss (dB)	AMP factor (dB)	Reading (dBuV)	Emission Level (dBuV/m)	Limits (dBuV/m)	Margin (dB)	Remark
1	5451.050	34.22	9.76	35.25	45.39	54.12	74.00	19.88	Peak
2	5460.000	34.23	9.76	35.25	42.77	51.51	74.00	22.49	Peak
3	5715.000	34.39	9.88	35.12	42.95	52.10	74.00	21.90	Peak
4	5725.000	34.39	9.89	35.12	47.91	57.07	74.00	16.93	Peak
5	5751.190	34.40	9.90	35.11	89.43	98.62	74.00	-24.62	Peak

Remarks: 1. Emission Level= Antenna Factor + Cable Loss + Reading - Amp Factor
 2. The emission levels that are 20dB below the official limit are not reported.

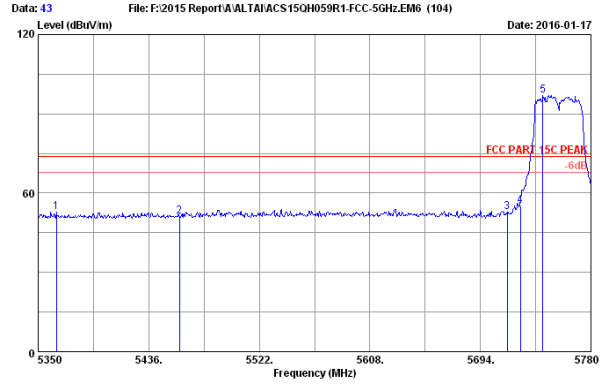

Site no. : 3m Chamber Data no. : 43
 Dis. / Ant. : 3m 2014 3115 9607-4877 Ant. pol. : VERTICAL
 Limit : FCC PART 15C PEAK
 Env. / Ins. : 23°C/54%
 Engineer : Leo-L1
 EUT : Altai A3w Indoor Dual-band 3x3 802.11ac WiFi AP
 Power rating : DC 56V From POE Input AC 120V/60Hz
 Test Mode : IEEE802.11nHT40 5755MHz Tx
 WA3311NAC-W

No.	Freq. (MHz)	Ant. Factor (dB/m)	Cable Loss (dB)	AMP factor (dB)	Reading (dBuV)	Emission Level (dBuV/m)	Limits (dBuV/m)	Margin (dB)	Remark
1	5364.190	34.06	9.72	35.28	44.37	52.67	74.00	21.13	Peak
2	5460.000	34.23	9.76	35.25	42.46	51.20	74.00	22.80	Peak
3	5715.000	34.39	9.88	35.12	43.50	52.65	74.00	21.35	Peak
4	5725.000	34.39	9.89	35.12	46.16	55.32	74.00	18.68	Peak
5	5742.590	34.40	9.90	35.11	87.83	97.02	74.00	-23.02	Peak

Remarks: 1. Emission Level= Antenna Factor + Cable Loss + Reading - Amp Factor
 2. The emission levels that are 20dB below the official limit are not reported.

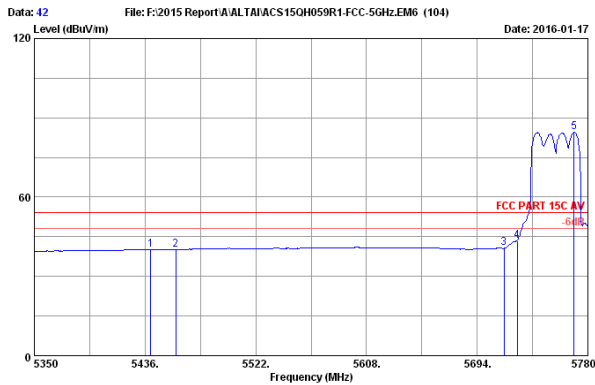

Site no. : 3m Chamber Data no. : 42
 Dis. / Ant. : 3m 2014 3115 9607-4877 Ant. pol. : HORIZONTAL
 Limit : FCC PART 15C AV
 Env. / Ins. : 23°C/54%
 Engineer : Leo-L1
 EUT : Altai A3w Indoor Dual-band 3x3 802.11ac WiFi AP
 Power rating : DC 56V From POE Input AC 120V/60Hz
 Test Mode : IEEE802.11nHT40 5755MHz Tx
 WA3311NAC-W

No.	Freq. (MHz)	Ant. Factor (dB/m)	Cable Loss (dB)	AMP factor (dB)	Reading (dBuV)	Emission Level (dBuV/m)	Limits (dBuV/m)	Margin (dB)	Remark
1	5440.300	34.20	9.75	35.25	31.44	40.14	54.00	13.86	Average
2	5460.000	34.23	9.76	35.25	31.35	40.09	54.00	13.91	Average
3	5715.000	34.39	9.88	35.12	31.51	40.66	54.00	13.34	Average
4	5725.000	34.39	9.89	35.12	34.32	43.48	54.00	10.52	Average
5	5769.250	34.41	9.91	35.10	75.21	84.43	54.00	-30.43	Average

Remarks: 1. Emission Level= Antenna Factor + Cable Loss + Reading - Amp Factor
 2. The emission levels that are 20dB below the official limit are not reported.

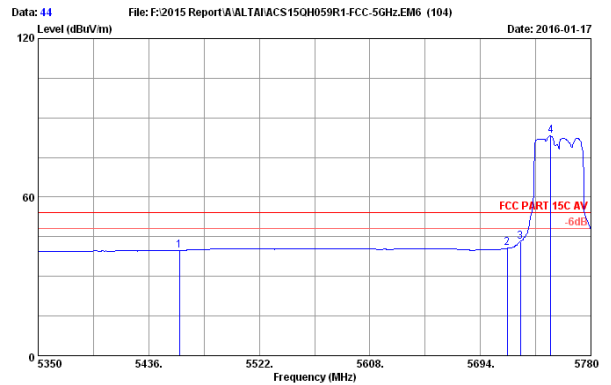

Site no. : 3m Chamber Data no. : 44
 Dis. / Ant. : 3m 2014 3115 9607-4877 Ant. pol. : VERTICAL
 Limit : FCC PART 15C AV
 Env. / Ins. : 23°C/54%
 Engineer : Leo-L1
 EUT : Altai A3w Indoor Dual-band 3x3 802.11ac WiFi AP
 Power rating : DC 56V From POE Input AC 120V/60Hz
 Test Mode : IEEE802.11nHT40 5755MHz Tx
 WA3311NAC-W

No.	Freq. (MHz)	Ant. Factor (dB/m)	Cable Loss (dB)	AMP factor (dB)	Reading (dBuV)	Emission Level (dBuV/m)	Limits (dBuV/m)	Margin (dB)	Remark
1	5460.000	34.23	9.76	35.25	31.12	39.86	54.00	14.14	Average
2	5715.000	34.39	9.88	35.12	31.47	40.62	54.00	13.38	Average
3	5725.000	34.39	9.89	35.12	34.02	43.18	54.00	10.82	Average
4	5748.610	34.40	9.90	35.11	74.00	83.19	54.00	-29.19	Average

Remarks: 1. Emission Level= Antenna Factor + Cable Loss + Reading - Amp Factor
 2. The emission levels that are 20dB below the official limit are not reported.

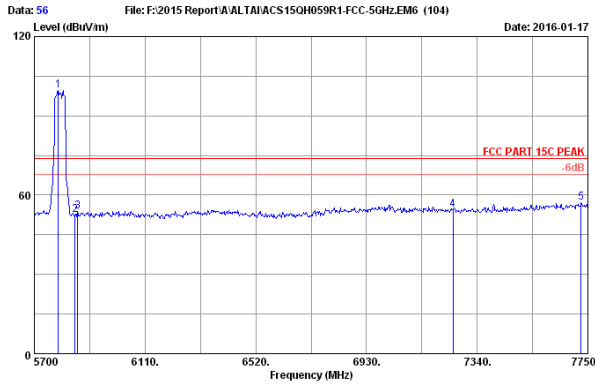

Site no. : 3m Chamber Data no. : 56
 Dis. / Ant. : 3m 2014 3115 9607-4877 Ant. pol. : HORIZONTAL
 Limit : FCC PART 15C PEAK
 Env. / Ins. : 23°C/54%
 Engineer : Leo-Li
 EUT : Altai A3w Indoor Dual-band 3x3 802.11ac WiFi AP
 Power rating : DC 56V From POE Input AC 120V/60Hz
 Test Mode : IEEE802.11nHT40 5795MHz Tx
 WA3311NAC-W

No.	Freq. (MHz)	Ant. Factor (dB/m)	Cable Loss (dB)	AMP factor (dB)	Reading (dBuV)	Emission Level (dBuV/m)	Limits (dBuV/m)	Margin (dB)	Remark
1	5788.150	34.42	9.91	35.09	90.43	99.67	74.00	-25.67	Peak
2	5850.000	34.44	9.95	35.07	43.20	52.52	74.00	21.48	Peak
3	5860.000	34.45	9.95	35.07	44.36	53.69	74.00	20.31	Peak
4	7250.000	35.91	10.74	35.50	43.43	54.58	74.00	19.42	Peak
5	7725.400	36.64	11.20	35.69	45.14	57.29	74.00	16.71	Peak

Remarks: 1. Emission Level= Antenna Factor + Cable Loss + Reading - Amp Factor
 2. The emission levels that are 20dB below the official limit are not reported.

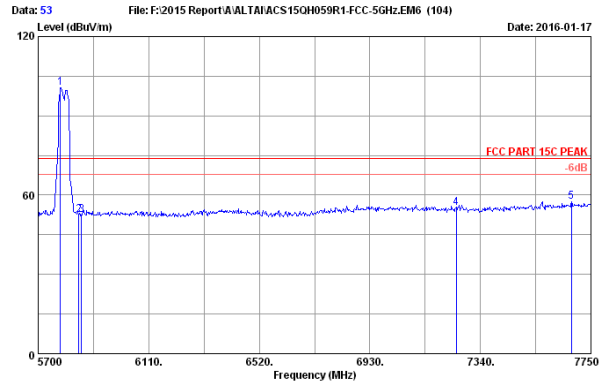

Site no. : 3m Chamber Data no. : 53
 Dis. / Ant. : 3m 2014 3115 9607-4877 Ant. pol. : VERTICAL
 Limit : FCC PART 15C PEAK
 Env. / Ins. : 23°C/54%
 Engineer : Leo-Li
 EUT : Altai A3w Indoor Dual-band 3x3 802.11ac WiFi AP
 Power rating : DC 56V From POE Input AC 120V/60Hz
 Test Mode : IEEE802.11nHT40 5795MHz Tx
 WA3311NAC-W

No.	Freq. (MHz)	Ant. Factor (dB/m)	Cable Loss (dB)	AMP factor (dB)	Reading (dBuV)	Emission Level (dBuV/m)	Limits (dBuV/m)	Margin (dB)	Remark
1	5782.000	34.41	9.91	35.10	91.32	100.54	74.00	-26.54	Peak
2	5850.000	34.44	9.95	35.07	43.26	52.58	74.00	21.42	Peak
3	5860.000	34.45	9.95	35.07	43.06	52.39	74.00	21.61	Peak
4	7250.000	35.91	10.74	35.50	44.12	55.27	74.00	18.73	Peak
5	7678.250	36.61	11.16	35.67	45.37	57.47	74.00	16.53	Peak

Remarks: 1. Emission Level= Antenna Factor + Cable Loss + Reading - Amp Factor
 2. The emission levels that are 20dB below the official limit are not reported.

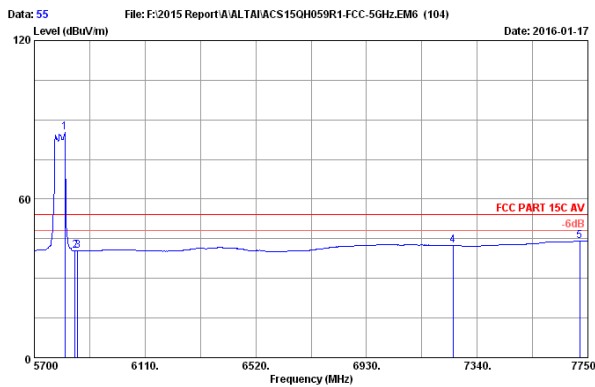

Site no. : 3m Chamber Data no. : 55
 Dis. / Ant. : 3m 2014 3115 9607-4877 Ant. pol. : HORIZONTAL
 Limit : FCC PART 15C AV
 Env. / Ins. : 23°C/54%
 Engineer : Leo-Li
 EUT : Altai A3w Indoor Dual-band 3x3 802.11ac WiFi AP
 Power rating : DC 56V From POE Input AC 120V/60Hz
 Test Mode : IEEE802.11nHT40 5795MHz Tx
 WA3311NAC-W

No.	Freq. (MHz)	Ant. Factor (dB/m)	Cable Loss (dB)	AMP factor (dB)	Reading (dBuV)	Emission Level (dBuV/m)	Limits (dBuV/m)	Margin (dB)	Remark
1	5812.750	34.43	9.93	35.08	75.92	85.20	54.00	-31.20	Average
2	5850.000	34.44	9.95	35.07	30.98	40.30	54.00	13.70	Average
3	5860.000	34.45	9.95	35.07	31.02	40.35	54.00	13.65	Average
4	7250.000	35.91	10.74	35.50	31.27	42.42	54.00	11.58	Average
5	7719.250	36.63	11.20	35.69	31.97	44.11	54.00	9.89	Average

Remarks: 1. Emission Level= Antenna Factor + Cable Loss + Reading - Amp Factor
 2. The emission levels that are 20dB below the official limit are not reported.

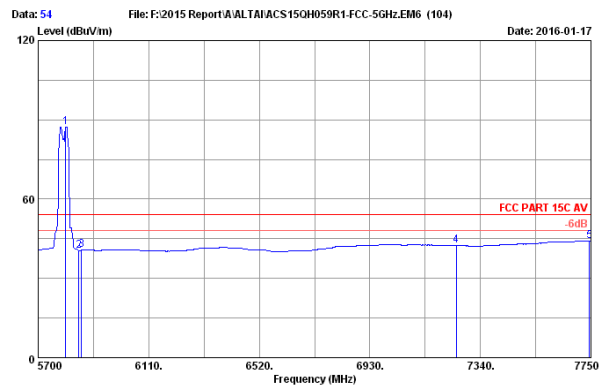

Site no. : 3m Chamber Data no. : 54
 Dis. / Ant. : 3m 2014 3115 9607-4877 Ant. pol. : VERTICAL
 Limit : FCC PART 15C AV
 Env. / Ins. : 23°C/54%
 Engineer : Leo-Li
 EUT : Altai A3w Indoor Dual-band 3x3 802.11ac WiFi AP
 Power rating : DC 56V From POE Input AC 120V/60Hz
 Test Mode : IEEE802.11nHT40 5795MHz Tx
 WA3311NAC-W

No.	Freq. (MHz)	Ant. Factor (dB/m)	Cable Loss (dB)	AMP factor (dB)	Reading (dBuV)	Emission Level (dBuV/m)	Limits (dBuV/m)	Margin (dB)	Remark
1	5802.500	34.42	9.92	35.09	78.06	87.31	54.00	-33.31	Average
2	5850.000	34.44	9.95	35.07	31.29	40.61	54.00	13.39	Average
3	5860.000	34.45	9.95	35.07	31.32	40.65	54.00	13.35	Average
4	7250.000	35.91	10.74	35.50	31.29	42.44	54.00	11.56	Average
5	7743.850	36.65	11.22	35.70	31.96	44.13	54.00	9.87	Average

Remarks: 1. Emission Level= Antenna Factor + Cable Loss + Reading - Amp Factor
 2. The emission levels that are 20dB below the official limit are not reported.

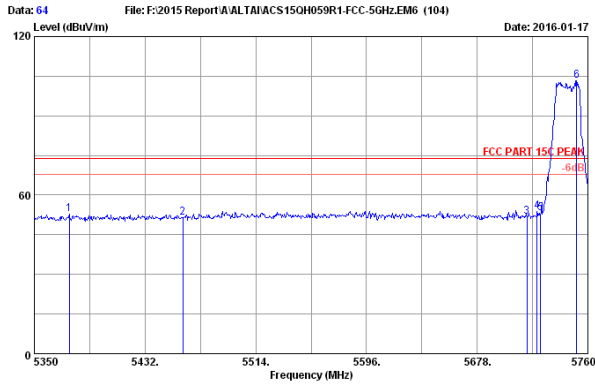

Data: 64 File: F:\2015 Report\A\ALTAI\ACS15QH059R1-FCC-5GHz.EM6 (104) Date: 2016-01-17

Site no. : 3m Chamber Data no. : 64
 Dis. / Ant. : 3m 2014 3115 9607-4877 Ant. pol. : HORIZONTAL
 Limit : FCC PART 15C PEAK
 Env. / Ins. : 23°C/54%
 Engineer : Leo-Li
 EUT : Altai A3w Indoor Dual-band 3x3 802.11ac WiFi AP
 Power rating : DC 56V From POE Input AC 120V/60Hz
 Test Mode : IEEE802.11ac VHT20 5745MHz Tx
 WA3311NAC-W

No.	Freq. (MHz)	Ant. Factor (dB/m)	Cable Loss (dB)	AMP factor (dB)	Reading (dBuV)	Emission Level (dBuV/m)	Limits (dBuV/m)	Margin (dB)	Remark
1	5375.830	34.08	9.76	35.28	44.28	52.80	74.00	21.20	Peak
2	5460.000	34.23	9.76	35.25	42.76	51.50	74.00	22.50	Peak
3	5715.000	34.39	9.88	35.12	42.57	51.72	74.00	22.28	Peak
4	5722.280	34.39	9.89	35.12	44.55	53.71	74.00	20.29	Peak
5	5725.000	34.39	9.89	35.12	43.87	53.03	74.00	20.97	Peak
6	5751.800	34.40	9.90	35.11	94.25	103.44	74.00	-29.44	Peak

Remarks: 1. Emission Level= Antenna Factor + Cable Loss + Reading - Amp Factor
 2. The emission levels that are 20dB below the official limit are not reported.

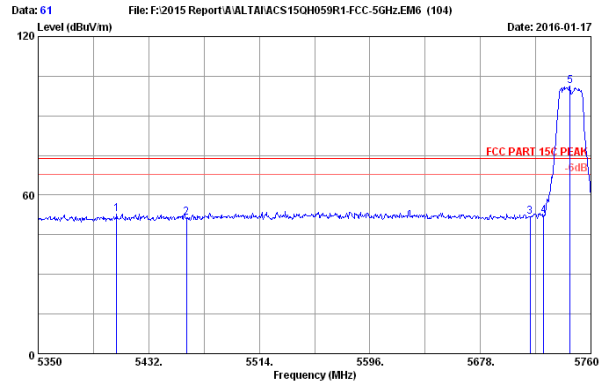

Data: 61 File: F:\2015 Report\A\ALTAI\ACS15QH059R1-FCC-5GHz.EM6 (104) Date: 2016-01-17

Site no. : 3m Chamber Data no. : 61
 Dis. / Ant. : 3m 2014 3115 9607-4877 Ant. pol. : VERTICAL
 Limit : FCC PART 15C PEAK
 Env. / Ins. : 23°C/54%
 Engineer : Leo-Li
 EUT : Altai A3w Indoor Dual-band 3x3 802.11ac WiFi AP
 Power rating : DC 56V From POE Input AC 120V/60Hz
 Test Mode : IEEE802.11ac VHT20 5745MHz Tx
 WA3311NAC-W

No.	Freq. (MHz)	Ant. Factor (dB/m)	Cable Loss (dB)	AMP factor (dB)	Reading (dBuV)	Emission Level (dBuV/m)	Limits (dBuV/m)	Margin (dB)	Remark
1	5408.220	34.14	9.74	35.27	44.29	52.90	74.00	21.10	Peak
2	5460.000	34.23	9.76	35.25	42.61	51.35	74.00	22.65	Peak
3	5715.000	34.39	9.88	35.12	42.78	51.93	74.00	22.07	Peak
4	5725.000	34.39	9.89	35.12	42.93	52.09	74.00	21.91	Peak
5	5744.420	34.40	9.90	35.11	92.08	101.27	74.00	-27.27	Peak

Remarks: 1. Emission Level= Antenna Factor + Cable Loss + Reading - Amp Factor
 2. The emission levels that are 20dB below the official limit are not reported.

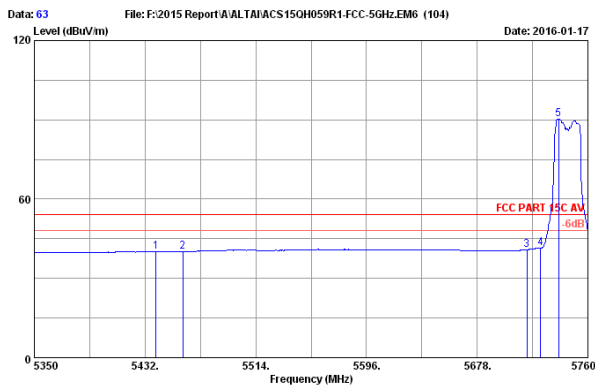

Data: 63 File: F:\2015 Report\A\ALTAI\ACS15QH059R1-FCC-5GHz.EM6 (104) Date: 2016-01-17

Site no. : 3m Chamber Data no. : 63
 Dis. / Ant. : 3m 2014 3115 9607-4877 Ant. pol. : HORIZONTAL
 Limit : FCC PART 15C AV
 Env. / Ins. : 23°C/54%
 Engineer : Leo-Li
 EUT : Altai A3w Indoor Dual-band 3x3 802.11ac WiFi AP
 Power rating : DC 56V From POE Input AC 120V/60Hz
 Test Mode : IEEE802.11ac VHT20 5745MHz Tx
 WA3311NAC-W

No.	Freq. (MHz)	Ant. Factor (dB/m)	Cable Loss (dB)	AMP factor (dB)	Reading (dBuV)	Emission Level (dBuV/m)	Limits (dBuV/m)	Margin (dB)	Remark
1	5440.200	34.20	9.75	35.25	31.52	40.22	54.00	13.78	Average
2	5460.000	34.23	9.76	35.25	31.38	40.12	54.00	13.88	Average
3	5715.000	34.39	9.88	35.12	31.61	40.76	54.00	13.24	Average
4	5725.000	34.39	9.89	35.12	32.24	41.40	54.00	12.60	Average
5	5738.270	34.40	9.90	35.11	81.14	90.33	54.00	-36.33	Average

Remarks: 1. Emission Level= Antenna Factor + Cable Loss + Reading - Amp Factor
 2. The emission levels that are 20dB below the official limit are not reported.

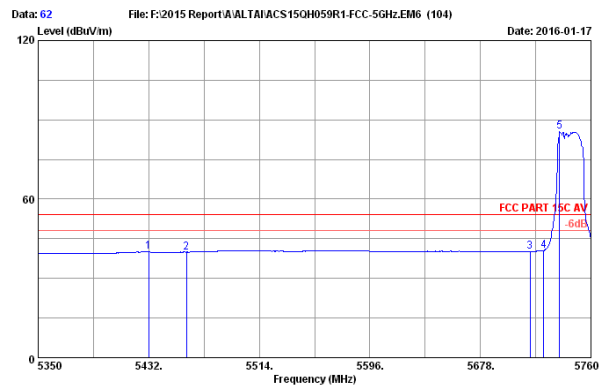

Data: 62 File: F:\2015 Report\A\ALTAI\ACS15QH059R1-FCC-5GHz.EM6 (104) Date: 2016-01-17

Site no. : 3m Chamber Data no. : 62
 Dis. / Ant. : 3m 2014 3115 9607-4877 Ant. pol. : VERTICAL
 Limit : FCC PART 15C AV
 Env. / Ins. : 23°C/54%
 Engineer : Leo-Li
 EUT : Altai A3w Indoor Dual-band 3x3 802.11ac WiFi AP
 Power rating : DC 56V From POE Input AC 120V/60Hz
 Test Mode : IEEE802.11ac VHT20 5745MHz Tx
 WA3311NAC-W

No.	Freq. (MHz)	Ant. Factor (dB/m)	Cable Loss (dB)	AMP factor (dB)	Reading (dBuV)	Emission Level (dBuV/m)	Limits (dBuV/m)	Margin (dB)	Remark
1	5492.000	34.18	9.75	35.26	31.33	40.00	54.00	14.00	Average
2	5460.000	34.23	9.76	35.25	31.20	39.94	54.00	14.06	Average
3	5715.000	34.39	9.88	35.12	31.07	40.22	54.00	13.78	Average
4	5725.000	34.39	9.89	35.12	31.42	40.58	54.00	13.42	Average
5	5736.630	34.40	9.90	35.12	76.25	85.43	54.00	-31.43	Average

Remarks: 1. Emission Level= Antenna Factor + Cable Loss + Reading - Amp Factor
 2. The emission levels that are 20dB below the official limit are not reported.

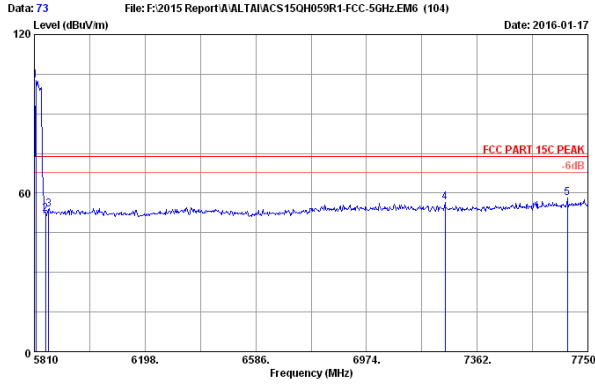

Site no. : 3m Chamber Data no. : 73
 Dis. / Ant. : 3m 2014 3115 9607-4877 Ant. pol. : HORIZONTAL
 Limit : FCC PART 15C PEAK
 Env. / Ins. : 23°C/54%
 Engineer : Leo-Li
 EUT : Altai A3w Indoor Dual-band 3x3 802.11ac WiFi AP
 Power rating : DC 56V From POE Input AC 120V/60Hz
 Test Mode : IEEE802.11ac VHT20 5825MHz Tx
 WA3311NAC-W

No.	Freq. (MHz)	Ant. Factor (dB/m)	Cable Loss (dB)	AMP factor (dB)	Reading (dBuV)	Emission Level (dBuV/m)	Limits (dBuV/m)	Margin (dB)	Remark
1	5815.820	34.43	9.93	35.08	93.18	102.46	74.00	-28.46	Peak
2	5850.000	34.44	9.95	35.07	42.78	52.10	74.00	21.90	Peak
3	5860.000	34.45	9.95	35.07	44.54	53.87	74.00	20.13	Peak
4	7250.000	35.91	10.74	35.50	45.24	56.39	74.00	17.61	Peak
5	7678.220	36.61	11.16	35.67	45.90	58.00	74.00	16.00	Peak

Remarks: 1. Emission Level= Antenna Factor + Cable Loss + Reading - Amp Factor
 2. The emission levels that are 20dB below the official limit are not reported.

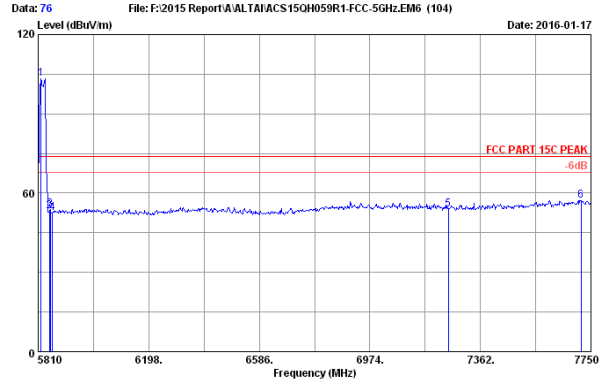

Site no. : 3m Chamber Data no. : 76
 Dis. / Ant. : 3m 2014 3115 9607-4877 Ant. pol. : VERTICAL
 Limit : FCC PART 15C PEAK
 Env. / Ins. : 23°C/54%
 Engineer : Leo-Li
 EUT : Altai A3w Indoor Dual-band 3x3 802.11ac WiFi AP
 Power rating : DC 56V From POE Input AC 120V/60Hz
 Test Mode : IEEE802.11ac VHT20 5825MHz Tx
 WA3311NAC-W

No.	Freq. (MHz)	Ant. Factor (dB/m)	Cable Loss (dB)	AMP factor (dB)	Reading (dBuV)	Emission Level (dBuV/m)	Limits (dBuV/m)	Margin (dB)	Remark
1	5819.700	34.43	9.93	35.08	94.07	103.35	74.00	-29.35	Peak
2	5850.000	34.44	9.95	35.07	43.85	53.17	74.00	20.83	Peak
3	5852.680	34.44	9.95	35.07	44.34	53.66	74.00	20.34	Peak
4	5860.000	34.45	9.95	35.07	43.15	52.48	74.00	21.52	Peak
5	7250.000	35.91	10.74	35.50	42.81	53.96	74.00	20.04	Peak
6	7715.080	36.63	11.20	35.69	45.09	57.23	74.00	16.77	Peak

Remarks: 1. Emission Level= Antenna Factor + Cable Loss + Reading - Amp Factor
 2. The emission levels that are 20dB below the official limit are not reported.

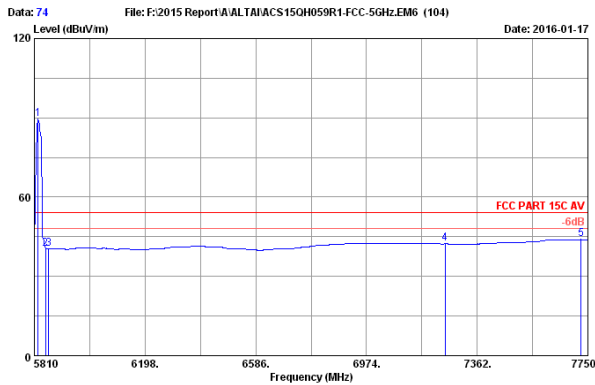

Site no. : 3m Chamber Data no. : 74
 Dis. / Ant. : 3m 2014 3115 9607-4877 Ant. pol. : HORIZONTAL
 Limit : FCC PART 15C AV
 Env. / Ins. : 23°C/54%
 Engineer : Leo-Li
 EUT : Altai A3w Indoor Dual-band 3x3 802.11ac WiFi AP
 Power rating : DC 56V From POE Input AC 120V/60Hz
 Test Mode : IEEE802.11ac VHT20 5825MHz Tx
 WA3311NAC-W

No.	Freq. (MHz)	Ant. Factor (dB/m)	Cable Loss (dB)	AMP factor (dB)	Reading (dBuV)	Emission Level (dBuV/m)	Limits (dBuV/m)	Margin (dB)	Remark
1	5823.580	34.43	9.93	35.08	80.29	89.57	54.00	-35.57	Average
2	5850.000	34.44	9.95	35.07	31.28	40.60	54.00	13.40	Average
3	5860.000	34.45	9.95	35.07	31.05	40.38	54.00	13.62	Average
4	7250.000	35.91	10.74	35.50	31.15	42.30	54.00	11.70	Average
5	7726.720	36.64	11.20	35.69	31.81	43.96	54.00	10.04	Average

Remarks: 1. Emission Level= Antenna Factor + Cable Loss + Reading - Amp Factor
 2. The emission levels that are 20dB below the official limit are not reported.

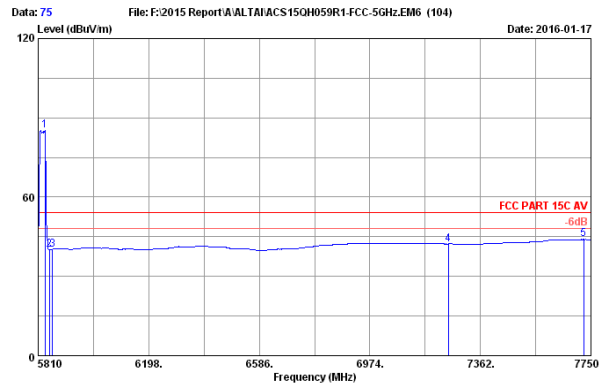

Site no. : 3m Chamber Data no. : 75
 Dis. / Ant. : 3m 2014 3115 9607-4877 Ant. pol. : VERTICAL
 Limit : FCC PART 15C AV
 Env. / Ins. : 23°C/54%
 Engineer : Leo-Li
 EUT : Altai A3w Indoor Dual-band 3x3 802.11ac WiFi AP
 Power rating : DC 56V From POE Input AC 120V/60Hz
 Test Mode : IEEE802.11ac VHT20 5825MHz Tx
 WA3311NAC-W

No.	Freq. (MHz)	Ant. Factor (dB/m)	Cable Loss (dB)	AMP factor (dB)	Reading (dBuV)	Emission Level (dBuV/m)	Limits (dBuV/m)	Margin (dB)	Remark
1	5833.280	34.44	9.94	35.08	76.04	85.34	54.00	-31.34	Average
2	5850.000	34.44	9.95	35.07	30.91	40.23	54.00	13.77	Average
3	5860.000	34.45	9.95	35.07	30.95	40.28	54.00	13.72	Average
4	7250.000	35.91	10.74	35.50	31.13	42.28	54.00	11.72	Average
5	7724.780	36.64	11.20	35.69	31.84	43.99	54.00	10.01	Average

Remarks: 1. Emission Level= Antenna Factor + Cable Loss + Reading - Amp Factor
 2. The emission levels that are 20dB below the official limit are not reported.

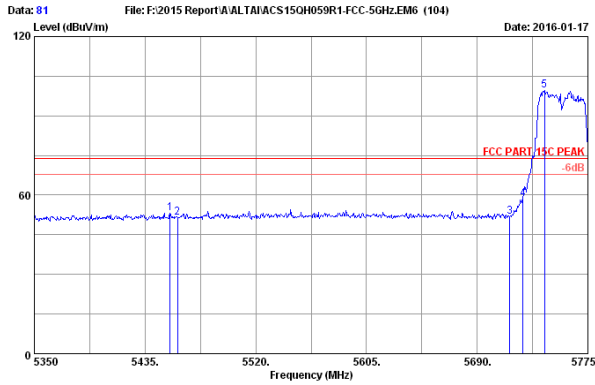

Site no. : 3m Chamber Data no. : 81
 Dis. / Ant. : 3m 2014 3115 9607-4877 Ant. pol. : HORIZONTAL
 Limit : FCC PART 15C PEAK
 Env. / Ins. : 23°C/54%
 Engineer : Leo-Li
 EUT : Altai A3w Indoor Dual-band 3x3 802.11ac WiFi AP
 Power rating : DC 56V From POE Input AC 120V/60Hz
 Test Mode : IEEE802.11ac VHT40 5755MHz Tx
 WA3311NAC-W

No.	Freq. (MHz)	Ant. Factor (dB/m)	Cable Loss (dB)	AMP factor (dB)	Reading (dBuV)	Emission Level (dBuV/m)	Limits (dBuV/m)	Margin (dB)	Remark
1	5454.125	34.22	9.76	35.25	44.43	53.16	74.00	20.84	Peak
2	5460.000	34.23	9.76	35.25	42.90	51.64	74.00	22.36	Peak
3	5715.000	34.39	9.88	35.12	42.82	51.97	74.00	22.03	Peak
4	5725.000	34.39	9.89	35.12	49.49	58.65	74.00	15.35	Peak
5	5741.850	34.40	9.90	35.11	90.43	99.62	74.00	-25.62	Peak

Remarks: 1. Emission Level= Antenna Factor + Cable Loss + Reading - Amp Factor
 2. The emission levels that are 20dB below the official limit are not reported.

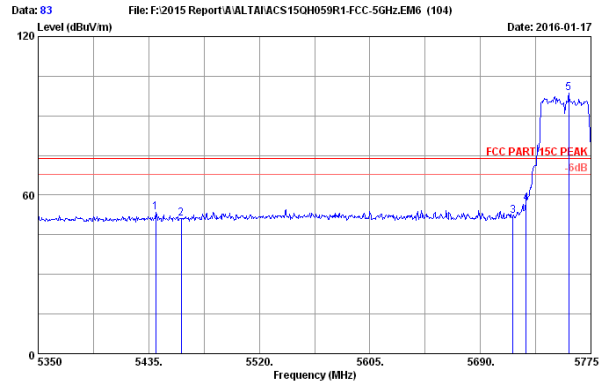

Site no. : 3m Chamber Data no. : 83
 Dis. / Ant. : 3m 2014 3115 9607-4877 Ant. pol. : VERTICAL
 Limit : FCC PART 15C PEAK
 Env. / Ins. : 23°C/54%
 Engineer : Leo-Li
 EUT : Altai A3w Indoor Dual-band 3x3 802.11ac WiFi AP
 Power rating : DC 56V From POE Input AC 120V/60Hz
 Test Mode : IEEE802.11ac VHT40 5755MHz Tx
 WA3311NAC-W

No.	Freq. (MHz)	Ant. Factor (dB/m)	Cable Loss (dB)	AMP factor (dB)	Reading (dBuV)	Emission Level (dBuV/m)	Limits (dBuV/m)	Margin (dB)	Remark
1	5440.525	34.20	9.75	35.25	44.90	59.60	74.00	20.40	Peak
2	5460.000	34.23	9.76	35.25	42.34	51.08	74.00	22.92	Peak
3	5715.000	34.39	9.88	35.12	42.93	52.08	74.00	21.92	Peak
4	5725.000	34.39	9.89	35.12	47.54	56.70	74.00	17.30	Peak
5	5758.000	34.41	9.91	35.11	89.41	98.62	74.00	-24.62	Peak

Remarks: 1. Emission Level= Antenna Factor + Cable Loss + Reading - Amp Factor
 2. The emission levels that are 20dB below the official limit are not reported.

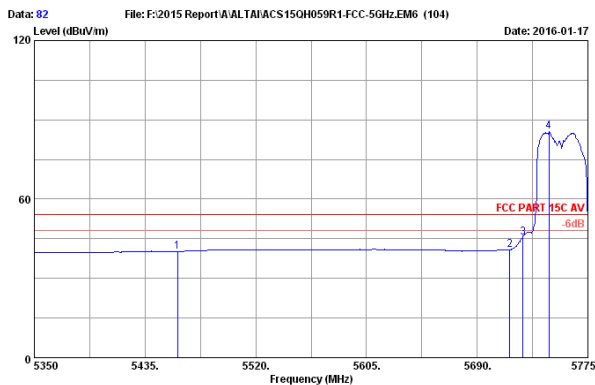

Site no. : 3m Chamber Data no. : 82
 Dis. / Ant. : 3m 2014 3115 9607-4877 Ant. pol. : HORIZONTAL
 Limit : FCC PART 15C AV
 Env. / Ins. : 23°C/54%
 Engineer : Leo-Li
 EUT : Altai A3w Indoor Dual-band 3x3 802.11ac WiFi AP
 Power rating : DC 56V From POE Input AC 120V/60Hz
 Test Mode : IEEE802.11ac VHT40 5755MHz Tx
 WA3311NAC-W

No.	Freq. (MHz)	Ant. Factor (dB/m)	Cable Loss (dB)	AMP factor (dB)	Reading (dBuV)	Emission Level (dBuV/m)	Limits (dBuV/m)	Margin (dB)	Remark
1	5460.000	34.23	9.76	35.25	31.42	40.16	54.00	13.84	Average
2	5715.000	34.39	9.88	35.12	31.59	40.84	54.00	13.16	Average
3	5725.000	34.39	9.89	35.12	36.37	45.53	54.00	8.47	Average
4	5745.250	34.40	9.90	35.11	76.23	85.42	54.00	-31.42	Average

Remarks: 1. Emission Level= Antenna Factor + Cable Loss + Reading - Amp Factor
 2. The emission levels that are 20dB below the official limit are not reported.

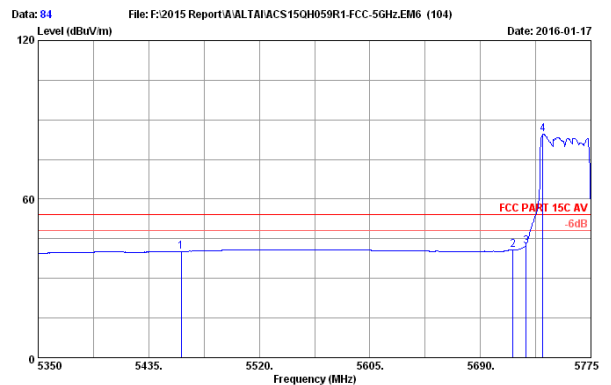

Site no. : 3m Chamber Data no. : 84
 Dis. / Ant. : 3m 2014 3115 9607-4877 Ant. pol. : VERTICAL
 Limit : FCC PART 15C AV
 Env. / Ins. : 23°C/54%
 Engineer : Leo-Li
 EUT : Altai A3w Indoor Dual-band 3x3 802.11ac WiFi AP
 Power rating : DC 56V From POE Input AC 120V/60Hz
 Test Mode : IEEE802.11ac VHT40 5755MHz Tx
 WA3311NAC-W

No.	Freq. (MHz)	Ant. Factor (dB/m)	Cable Loss (dB)	AMP factor (dB)	Reading (dBuV)	Emission Level (dBuV/m)	Limits (dBuV/m)	Margin (dB)	Remark
1	5460.000	34.23	9.76	35.25	31.49	40.23	54.00	13.77	Average
2	5715.000	34.39	9.88	35.12	31.49	40.64	54.00	13.36	Average
3	5725.000	34.39	9.89	35.12	32.98	42.14	54.00	11.86	Average
4	5738.025	34.40	9.90	35.11	75.31	84.50	54.00	-30.50	Average

Remarks: 1. Emission Level= Antenna Factor + Cable Loss + Reading - Amp Factor
 2. The emission levels that are 20dB below the official limit are not reported.

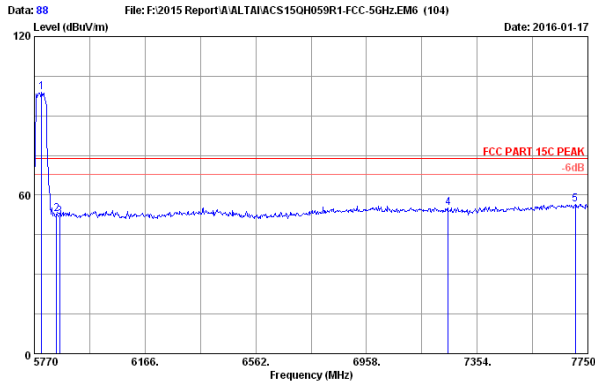

Data: 88 File: F:\2015 Report\A\ALTAIACS15QH059R1-FCC-5GHz.EM6 (104) Date: 2016-01-17

Site no. : 3m Chamber Data no. : 88
 Dis. / Ant. : 3m 2014 3115 9607-4877 Ant. pol. : HORIZONTAL
 Limit : FCC PART 15C PEAK
 Env. / Ins. : 23°C/54%
 Engineer : Leo-Li
 EUT : Altai A3w Indoor Dual-band 3x3 802.11ac WiFi AP
 Power rating : DC 56V From POE Input AC 120V/60Hz
 Test Mode : IEEE802.11ac VHT40 5795MHz Tx
 WA3311NAC-W

No.	Freq. (MHz)	Ant. Factor (dB/m)	Cable Loss (dB)	AMP factor (dB)	Reading (dBuV)	Emission Level (dBuV/m)	Limits (dBuV/m)	Margin (dB)	Remark
1	5795.740	34.42	9.92	35.09	89.54	98.79	74.00	-24.79	Peak
2	5850.000	34.44	9.95	35.07	43.60	52.92	74.00	21.08	Peak
3	5860.000	34.45	9.95	35.07	42.46	51.79	74.00	22.21	Peak
4	7250.000	35.91	10.74	35.50	44.15	55.30	74.00	18.70	Peak
5	7704.460	36.63	11.18	35.68	44.40	56.53	74.00	17.47	Peak

Remarks: 1. Emission Level= Antenna Factor + Cable Loss + Reading - Amp Factor
 2. The emission levels that are 20dB below the official limit are not reported.

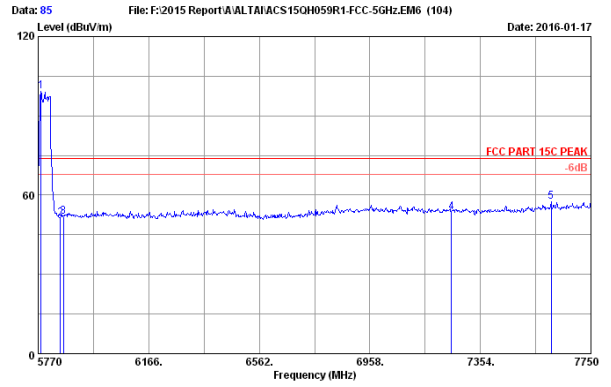

Data: 85 File: F:\2015 Report\A\ALTAIACS15QH059R1-FCC-5GHz.EM6 (104) Date: 2016-01-17

Site no. : 3m Chamber Data no. : 85
 Dis. / Ant. : 3m 2014 3115 9607-4877 Ant. pol. : VERTICAL
 Limit : FCC PART 15C PEAK
 Env. / Ins. : 23°C/54%
 Engineer : Leo-Li
 EUT : Altai A3w Indoor Dual-band 3x3 802.11ac WiFi AP
 Power rating : DC 56V From POE Input AC 120V/60Hz
 Test Mode : IEEE802.11ac VHT40 5795MHz Tx
 WA3311NAC-W

No.	Freq. (MHz)	Ant. Factor (dB/m)	Cable Loss (dB)	AMP factor (dB)	Reading (dBuV)	Emission Level (dBuV/m)	Limits (dBuV/m)	Margin (dB)	Remark
1	5779.900	34.41	9.91	35.10	89.96	99.18	74.00	-25.18	Peak
2	5850.000	34.44	9.95	35.07	41.83	51.15	74.00	22.85	Peak
3	5860.000	34.45	9.95	35.07	42.55	51.88	74.00	22.12	Peak
4	7250.000	35.91	10.74	35.50	42.29	53.44	74.00	20.56	Peak
5	7607.440	36.57	11.09	35.64	45.31	57.33	74.00	16.67	Peak

Remarks: 1. Emission Level= Antenna Factor + Cable Loss + Reading - Amp Factor
 2. The emission levels that are 20dB below the official limit are not reported.

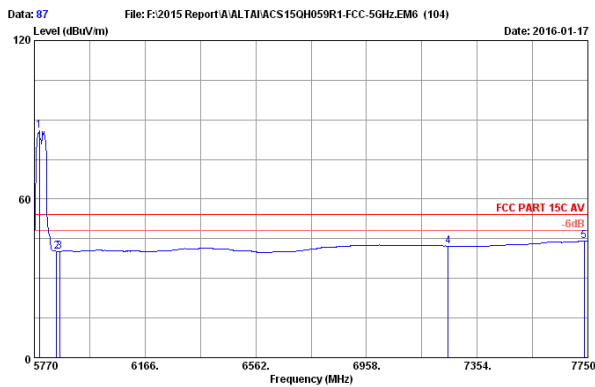

Data: 87 File: F:\2015 Report\A\ALTAIACS15QH059R1-FCC-5GHz.EM6 (104) Date: 2016-01-17

Site no. : 3m Chamber Data no. : 87
 Dis. / Ant. : 3m 2014 3115 9607-4877 Ant. pol. : HORIZONTAL
 Limit : FCC PART 15C AV
 Env. / Ins. : 23°C/54%
 Engineer : Leo-Li
 EUT : Altai A3w Indoor Dual-band 3x3 802.11ac WiFi AP
 Power rating : DC 56V From POE Input AC 120V/60Hz
 Test Mode : IEEE802.11ac VHT40 5795MHz Tx
 WA3311NAC-W

No.	Freq. (MHz)	Ant. Factor (dB/m)	Cable Loss (dB)	AMP factor (dB)	Reading (dBuV)	Emission Level (dBuV/m)	Limits (dBuV/m)	Margin (dB)	Remark
1	5787.820	34.42	9.91	35.09	76.57	85.81	54.00	-31.81	Average
2	5850.000	34.44	9.95	35.07	30.81	40.13	54.00	13.87	Average
3	5860.000	34.45	9.95	35.07	30.85	40.18	54.00	13.82	Average
4	7250.000	35.91	10.74	35.50	31.13	42.28	54.00	11.72	Average
5	7736.140	36.64	11.22	35.69	31.83	44.00	54.00	10.00	Average

Remarks: 1. Emission Level= Antenna Factor + Cable Loss + Reading - Amp Factor
 2. The emission levels that are 20dB below the official limit are not reported.

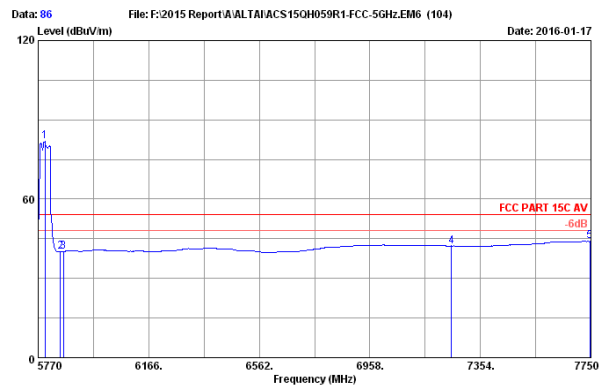

Data: 86 File: F:\2015 Report\A\ALTAIACS15QH059R1-FCC-5GHz.EM6 (104) Date: 2016-01-17

Site no. : 3m Chamber Data no. : 86
 Dis. / Ant. : 3m 2014 3115 9607-4877 Ant. pol. : VERTICAL
 Limit : FCC PART 15C AV
 Env. / Ins. : 23°C/54%
 Engineer : Leo-Li
 EUT : Altai A3w Indoor Dual-band 3x3 802.11ac WiFi AP
 Power rating : DC 56V From POE Input AC 120V/60Hz
 Test Mode : IEEE802.11ac VHT40 5795MHz Tx
 WA3311NAC-W

No.	Freq. (MHz)	Ant. Factor (dB/m)	Cable Loss (dB)	AMP factor (dB)	Reading (dBuV)	Emission Level (dBuV/m)	Limits (dBuV/m)	Margin (dB)	Remark
1	5793.760	34.42	9.92	35.09	72.52	81.77	54.00	-27.77	Average
2	5850.000	34.44	9.95	35.07	30.75	40.07	54.00	13.93	Average
3	5860.000	34.45	9.95	35.07	30.84	40.17	54.00	13.83	Average
4	7250.000	35.91	10.74	35.50	31.11	42.26	54.00	11.74	Average
5	7746.040	36.65	11.22	35.70	31.83	44.00	54.00	10.00	Average

Remarks: 1. Emission Level= Antenna Factor + Cable Loss + Reading - Amp Factor
 2. The emission levels that are 20dB below the official limit are not reported.

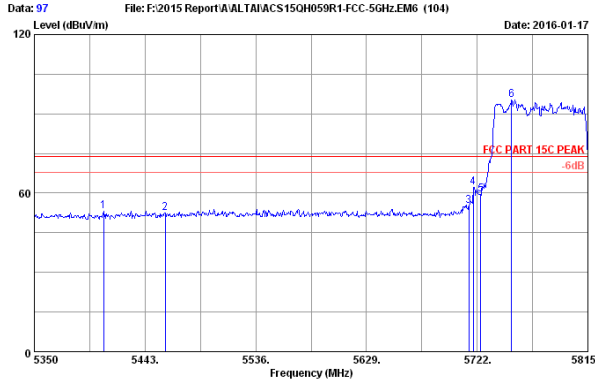

Site no. : 3m Chamber Data no. : 97
 Dis. / Ant. : 3m 2014 3115 9607-4877 Ant. pol. : HORIZONTAL
 Limit : FCC PART 15C PEAK
 Env. / Ins. : 23°C/54%
 Engineer : Leo-Li
 EUT : Altai A3w Indoor Dual-band 3x3 802.11ac WiFi AP
 Power rating : DC 56V From POE Input AC 120V/60Hz
 Test Mode : IEEE802.11ac VHT80 5775MHz Tx
 WA3311NAC-W

No.	Freq. (MHz)	Ant. Factor (dB/m)	Cable Loss (dB)	AMP factor (dB)	Reading (dBuV)	Emission Level (dBuV/m)	Limits (dBuV/m)	Margin (dB)	Remark
1	5408.125	34.14	9.76	35.27	44.68	53.29	74.00	20.71	Peak
2	5460.000	34.23	9.76	35.25	43.78	52.52	74.00	21.48	Peak
3	5715.000	34.39	9.88	35.12	46.11	55.26	74.00	18.74	Peak
4	5718.745	34.39	9.89	35.12	52.88	62.04	74.00	11.96	Peak
5	5725.000	34.39	9.89	35.12	50.20	59.36	74.00	14.64	Peak
6	5750.830	34.40	9.90	35.11	86.21	95.40	74.00	-21.40	Peak

Remarks: 1. Emission Level= Antenna Factor + Cable Loss + Reading -Amp Factor
 2. The emission levels that are 20dB below the official limit are not reported.

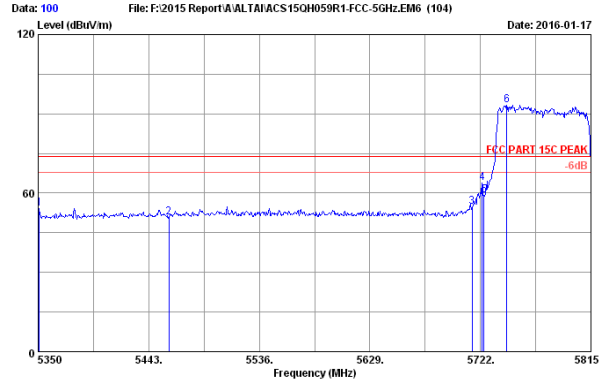

Site no. : 3m Chamber Data no. : 100
 Dis. / Ant. : 3m 2014 3115 9607-4877 Ant. pol. : VERTICAL
 Limit : FCC PART 15C PEAK
 Env. / Ins. : 23°C/54%
 Engineer : Leo-Li
 EUT : Altai A3w Indoor Dual-band 3x3 802.11ac WiFi AP
 Power rating : DC 56V From POE Input AC 120V/60Hz
 Test Mode : IEEE802.11ac VHT80 5775MHz Tx
 WA3311NAC-W

No.	Freq. (MHz)	Ant. Factor (dB/m)	Cable Loss (dB)	AMP factor (dB)	Reading (dBuV)	Emission Level (dBuV/m)	Limits (dBuV/m)	Margin (dB)	Remark
1	5350.930	34.04	9.71	35.29	45.79	54.25	74.00	19.75	Peak
2	5460.000	34.23	9.76	35.25	42.16	50.90	74.00	23.10	Peak
3	5715.000	34.39	9.88	35.12	45.63	54.78	74.00	19.22	Peak
4	5723.395	34.39	9.89	35.12	54.68	63.84	74.00	10.16	Peak
5	5725.000	34.39	9.89	35.12	49.92	59.08	74.00	14.92	Peak
6	5744.320	34.40	9.90	35.11	84.19	93.38	74.00	-19.38	Peak

Remarks: 1. Emission Level= Antenna Factor + Cable Loss + Reading -Amp Factor
 2. The emission levels that are 20dB below the official limit are not reported.

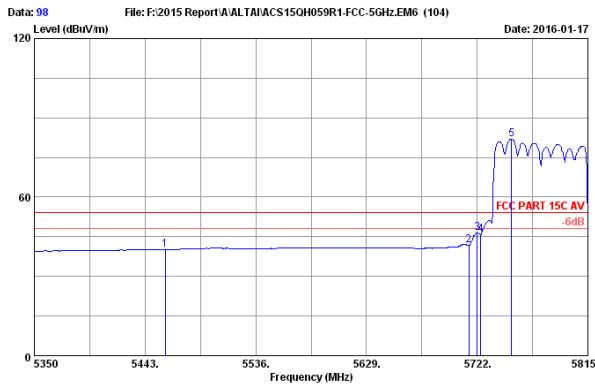

Site no. : 3m Chamber Data no. : 98
 Dis. / Ant. : 3m 2014 3115 9607-4877 Ant. pol. : HORIZONTAL
 Limit : FCC PART 15C AV
 Env. / Ins. : 23°C/54%
 Engineer : Leo-Li
 EUT : Altai A3w Indoor Dual-band 3x3 802.11ac WiFi AP
 Power rating : DC 56V From POE Input AC 120V/60Hz
 Test Mode : IEEE802.11ac VHT80 5775MHz Tx
 WA3311NAC-W

No.	Freq. (MHz)	Ant. Factor (dB/m)	Cable Loss (dB)	AMP factor (dB)	Reading (dBuV)	Emission Level (dBuV/m)	Limits (dBuV/m)	Margin (dB)	Remark
1	5460.000	34.23	9.76	35.25	31.38	40.12	54.00	13.88	Average
2	5715.000	34.39	9.88	35.12	32.66	41.81	54.00	12.19	Average
3	5722.000	34.39	9.89	35.12	37.21	46.37	54.00	7.63	Average
4	5725.000	34.39	9.89	35.12	36.69	45.85	54.00	8.15	Average
5	5750.830	34.40	9.90	35.11	72.85	82.04	54.00	-28.04	Average

Remarks: 1. Emission Level= Antenna Factor + Cable Loss + Reading -Amp Factor
 2. The emission levels that are 20dB below the official limit are not reported.

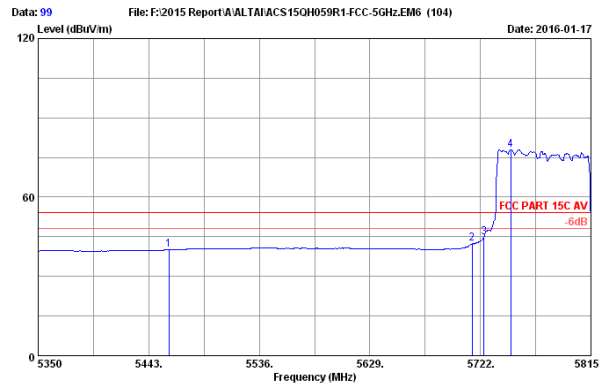

Site no. : 3m Chamber Data no. : 99
 Dis. / Ant. : 3m 2014 3115 9607-4877 Ant. pol. : VERTICAL
 Limit : FCC PART 15C AV
 Env. / Ins. : 23°C/54%
 Engineer : Leo-Li
 EUT : Altai A3w Indoor Dual-band 3x3 802.11ac WiFi AP
 Power rating : DC 56V From POE Input AC 120V/60Hz
 Test Mode : IEEE802.11ac VHT80 5775MHz Tx
 WA3311NAC-W

No.	Freq. (MHz)	Ant. Factor (dB/m)	Cable Loss (dB)	AMP factor (dB)	Reading (dBuV)	Emission Level (dBuV/m)	Limits (dBuV/m)	Margin (dB)	Remark
1	5460.000	34.23	9.76	35.25	31.25	39.99	54.00	14.01	Average
2	5715.000	34.39	9.88	35.12	33.18	42.33	54.00	11.67	Average
3	5725.000	34.39	9.89	35.12	35.53	44.69	54.00	9.31	Average
4	5747.575	34.40	9.90	35.11	68.78	77.97	54.00	-23.97	Average

Remarks: 1. Emission Level= Antenna Factor + Cable Loss + Reading -Amp Factor
 2. The emission levels that are 20dB below the official limit are not reported.

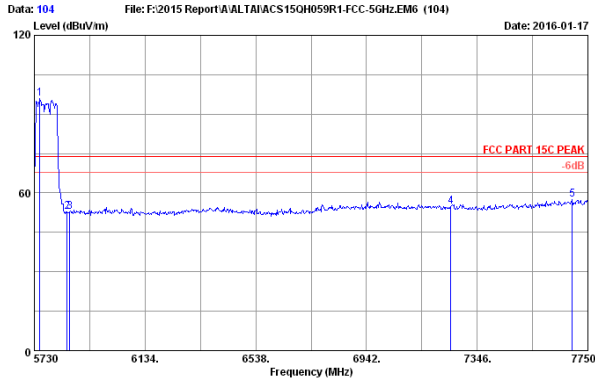

Site no. : 3m Chamber Data no. : 104
 Dis. / Ant. : 3m 2014 3115 9607-4877 Ant. pol. : HORIZONTAL
 Limit : FCC PART 15C PEAK
 Env. / Ins. : 23°C/54%
 Engineer : Leo-Li
 EUT : Altai A3w Indoor Dual-band 3x3 802.11ac WiFi AP
 Power rating : DC 56V From POE Input AC 120V/60Hz
 Test Mode : IEEE802.11ac VHT80 5775MHz Tx
 WA3311NAC-U

No.	Freq. (MHz)	Ant. Factor (dB/m)	Cable Loss (dB)	AMP factor (dB)	Reading (dBuV)	Emission Level (dBuV/m)	Limits (dBuV/m)	Margin (dB)	Remark
1	5750.200	34.40	9.90	35.11	86.87	96.06	74.00	-22.06	Peak
2	5850.000	34.44	9.95	35.07	43.35	52.67	74.00	21.33	Peak
3	5860.000	34.45	9.95	35.07	43.54	52.87	74.00	21.13	Peak
4	7250.000	35.91	10.74	35.50	43.77	54.92	74.00	19.08	Peak
5	7693.440	36.62	11.16	35.68	45.31	57.41	74.00	16.59	Peak

Remarks: 1. Emission Level= Antenna Factor + Cable Loss + Reading - Amp Factor
 2. The emission levels that are 20dB below the official limit are not reported.

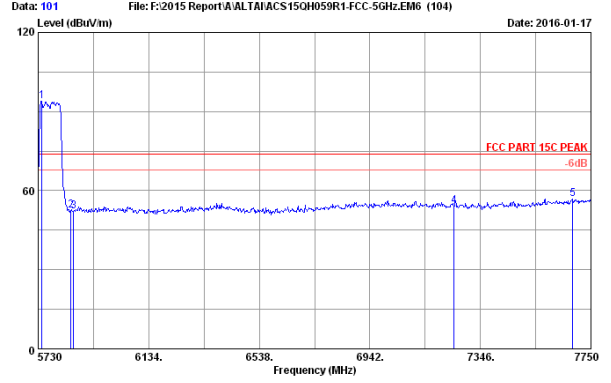

Site no. : 3m Chamber Data no. : 101
 Dis. / Ant. : 3m 2014 3115 9607-4877 Ant. pol. : VERTICAL
 Limit : FCC PART 15C PEAK
 Env. / Ins. : 23°C/54%
 Engineer : Leo-Li
 EUT : Altai A3w Indoor Dual-band 3x3 802.11ac WiFi AP
 Power rating : DC 56V From POE Input AC 120V/60Hz
 Test Mode : IEEE802.11ac VHT80 5775MHz Tx
 WA3311NAC-U

No.	Freq. (MHz)	Ant. Factor (dB/m)	Cable Loss (dB)	AMP factor (dB)	Reading (dBuV)	Emission Level (dBuV/m)	Limits (dBuV/m)	Margin (dB)	Remark
1	5744.140	34.40	9.90	35.11	84.71	93.90	74.00	-19.90	Peak
2	5850.000	34.44	9.95	35.07	43.10	52.42	74.00	21.58	Peak
3	5860.000	34.45	9.95	35.07	42.71	52.04	74.00	21.96	Peak
4	7250.000	35.91	10.74	35.50	43.06	54.21	74.00	19.79	Peak
5	7683.340	36.61	11.16	35.67	44.72	56.82	74.00	17.18	Peak

Remarks: 1. Emission Level= Antenna Factor + Cable Loss + Reading - Amp Factor
 2. The emission levels that are 20dB below the official limit are not reported.

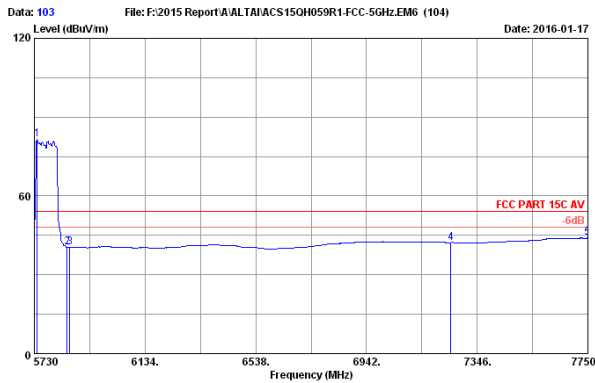

Site no. : 3m Chamber Data no. : 103
 Dis. / Ant. : 3m 2014 3115 9607-4877 Ant. pol. : HORIZONTAL
 Limit : FCC PART 15C AV
 Env. / Ins. : 23°C/54%
 Engineer : Leo-Li
 EUT : Altai A3w Indoor Dual-band 3x3 802.11ac WiFi AP
 Power rating : DC 56V From POE Input AC 120V/60Hz
 Test Mode : IEEE802.11ac VHT80 5775MHz Tx
 WA3311NAC-U

No.	Freq. (MHz)	Ant. Factor (dB/m)	Cable Loss (dB)	AMP factor (dB)	Reading (dBuV)	Emission Level (dBuV/m)	Limits (dBuV/m)	Margin (dB)	Remark
1	5740.100	34.40	9.90	35.11	72.25	81.44	54.00	-27.44	Average
2	5850.000	34.44	9.95	35.07	31.09	40.41	54.00	13.59	Average
3	5860.000	34.45	9.95	35.07	31.21	40.54	54.00	13.46	Average
4	7250.000	35.91	10.74	35.50	31.12	42.27	54.00	11.73	Average
5	7750.000	36.65	11.23	35.70	31.81	43.99	54.00	10.01	Average

Remarks: 1. Emission Level= Antenna Factor + Cable Loss + Reading - Amp Factor
 2. The emission levels that are 20dB below the official limit are not reported.

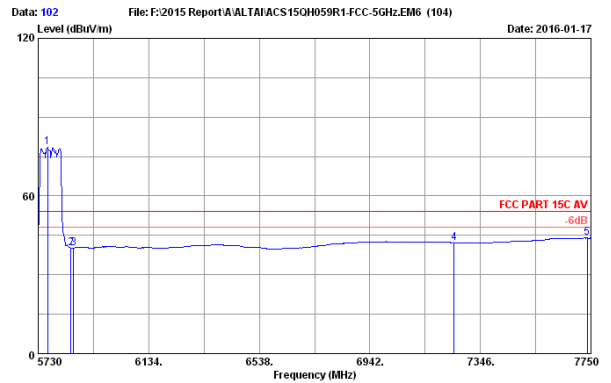

Site no. : 3m Chamber Data no. : 102
 Dis. / Ant. : 3m 2014 3115 9607-4877 Ant. pol. : VERTICAL
 Limit : FCC PART 15C AV
 Env. / Ins. : 23°C/54%
 Engineer : Leo-Li
 EUT : Altai A3w Indoor Dual-band 3x3 802.11ac WiFi AP
 Power rating : DC 56V From POE Input AC 120V/60Hz
 Test Mode : IEEE802.11ac VHT80 5775MHz Tx
 WA3311NAC-U

No.	Freq. (MHz)	Ant. Factor (dB/m)	Cable Loss (dB)	AMP factor (dB)	Reading (dBuV)	Emission Level (dBuV/m)	Limits (dBuV/m)	Margin (dB)	Remark
1	5764.340	34.41	9.91	35.10	69.20	78.42	54.00	-24.42	Average
2	5850.000	34.44	9.95	35.07	30.94	40.26	54.00	13.74	Average
3	5860.000	34.45	9.95	35.07	30.89	40.22	54.00	13.78	Average
4	7250.000	35.91	10.74	35.50	31.13	42.28	54.00	11.72	Average
5	7735.860	36.64	11.22	35.69	31.84	44.01	54.00	9.99	Average

Remarks: 1. Emission Level= Antenna Factor + Cable Loss + Reading - Amp Factor
 2. The emission levels that are 20dB below the official limit are not reported.

6. 6dB&26dB Bandwidth Test

6.1. Test Equipment

Item	Equipment	Manufacturer	Model No.	Serial No.	Last Cal.	Cal. Interval
1.	Spectrum	Agilent	N9030A	MY51380221	Oct.18,15	1 Year
2.	Attenuator (20dB)	Agilent	8491B	MY39262165	Apr.28,15	1 Year
3.	RF Cable	Marvelous Microwave Inc	SFL402105FLEX	NO.1	Oct.17.15	1 Year

6.2. Limit

6dB Bandwidth should be not less than 500kHz

6.3. Test Procedure

6dB Bandwidth:

The transmitter output was connected to a spectrum analyzer, The bandwidth of the fundamental frequency was measured by spectrum analyzer with 100kHz RBW and 300 KHz VBW for signal width below 20MHz and 300KHz RBW ,1MHz VBW for Above 20MHz signal Bandwidth.

26dB Bandwidth:

The transmitter output was connected to a spectrum analyzer, The bandwidth of the fundamental frequency was measured by spectrum analyzer with 100kHz RBW and 300 KHz VBW The 26dB bandwidth is defined as the total spectrum the power of which is higher than peak power minus 26dB.

6.4. Test Results

6dB bandwidth

EUT: Altai A3w Indoor Dual-band 3X3 802.11ac WiFi AP		
M/N: WA3311NAC-W		
Test date: 2016-02-05	Pressure: 101.8±1.0 kpa	Humidity:53.6±3.0%
Tested by: Leo-Li	Test site: RF site	Temperature: 22.6±0.6 °C

Test Mode	Frequency (MHz)	6dB bandwidth (MHz)			Limit (KHz)
		ANT 1	ANT 2	ANT 3	
11a	5745	16.38	16.38	16.39	≧ 500
	5785	16.42	16.42	16.40	≧ 500
	5825	16.37	16.37	16.37	≧ 500
11n HT20	5745	17.60	17.61	17.62	≧ 500
	5785	17.61	17.60	17.60	≧ 500
	5825	17.59	17.58	17.60	≧ 500
11n HT40	5755	36.32	36.34	36.14	≧ 500
	5795	36.10	36.08	35.77	≧ 500
11ac VHT20	5745	17.66	17.62	17.64	≧ 500
	5785	17.60	17.61	17.60	≧ 500
	5825	17.61	17.60	17.61	≧ 500
11ac VHT40	5755	36.33	36.32	36.36	≧ 500
	5795	36.33	36.34	36.33	≧ 500
11ac VHT80	5775	75.72	75.73	75.75	≧ 500
Conclusion : PASS					

26dB bandwidth

EUT: Altai A3w Indoor Dual-band 3X3 802.11ac WiFi AP		
M/N: WA3311NAC-W		
Test date: 2016-02-05	Pressure: 103.2±1.0kPa	Humidity: 53.7±3.0%
Tested by: Leo-Li	Test site: RF site	Temperature: 23.5±0.6 °C

Test Mode	Frequency (MHz)	26dB bandwidth (MHz)			Limit (KHz)
		ANT 1	ANT 2	ANT 3	
11a	5745	19.92	20.67	20.34	N/A
	5785	20.33	20.19	20.78	N/A
	5825	20.15	20.69	19.96	N/A
11n HT20	5745	21.55	21.09	21.22	N/A
	5785	21.26	21.02	21.05	N/A
	5825	20.80	20.91	21.19	N/A
11n HT40	5755	40.43	40.39	40.64	N/A
	5795	40.15	40.35	40.22	N/A
11ac VHT20	5745	21.14	21.00	21.11	N/A
	5785	20.85	21.01	20.79	N/A
	5825	20.87	20.77	20.93	N/A
11ac VHT40	5755	40.07	40.03	39.85	N/A
	5795	40.15	39.98	40.10	N/A
11ac VHT80	5775	80.00	80.25	79.62	N/A
Conclusion : PASS					

<p>6dB bandwidth</p>	
<p>ANT 1</p>	
<p>11a</p>	<p>11n HT20</p>
<p>5745MHz</p>	<p>5745MHz</p>
<p>Center Freq 5.745000000 GHz Center Freq 5.745000000 GHz Trig: Free Run AvgHold: 10/10 Radio Stn: None Radio Device: BTS</p> <p>Ref Offset: 11 dB Ref: 20.00 dBm</p> <p>Center Freq: 5.745 GHz Res BW: 100 kHz Span: 30 MHz Sweep: 2.933 ms #VBW: 300 kHz</p> <p>CF Step: 3000000 MHz</p> <p>Occupied Bandwidth: 16.463 MHz Total Power: 20.1 dBm</p> <p>Transmit Freq Error: -23.275 kHz OBW Power: 99.00 % x dB Bandwidth: 16.38 MHz x dB: -6.00 dB</p>	<p>Center Freq 5.745000000 GHz Center Freq 5.745000000 GHz Trig: Free Run AvgHold: 10/10 Radio Stn: None Radio Device: BTS</p> <p>Ref Offset: 11 dB Ref: 20.00 dBm</p> <p>Center Freq: 5.745 GHz Res BW: 100 kHz Span: 30 MHz Sweep: 2.933 ms #VBW: 300 kHz</p> <p>CF Step: 3000000 MHz</p> <p>Occupied Bandwidth: 17.656 MHz Total Power: 20.6 dBm</p> <p>Transmit Freq Error: -31.231 kHz OBW Power: 99.00 % x dB Bandwidth: 17.60 MHz x dB: -6.00 dB</p>
<p>5785MHz</p>	<p>5785MHz</p>
<p>Center Freq 5.785000000 GHz Center Freq 5.785000000 GHz Trig: Free Run AvgHold: 10/10 Radio Stn: None Radio Device: BTS</p> <p>Ref Offset: 11 dB Ref: 20.00 dBm</p> <p>Center Freq: 5.785 GHz Res BW: 100 kHz Span: 30 MHz Sweep: 2.933 ms #VBW: 300 kHz</p> <p>CF Step: 3000000 MHz</p> <p>Occupied Bandwidth: 16.460 MHz Total Power: 20.9 dBm</p> <p>Transmit Freq Error: -33.421 kHz OBW Power: 99.00 % x dB Bandwidth: 16.42 MHz x dB: -6.00 dB</p>	<p>Center Freq 5.785000000 GHz Center Freq 5.785000000 GHz Trig: Free Run AvgHold: 10/10 Radio Stn: None Radio Device: BTS</p> <p>Ref Offset: 11 dB Ref: 20.00 dBm</p> <p>Center Freq: 5.785 GHz Res BW: 100 kHz Span: 30 MHz Sweep: 2.933 ms #VBW: 300 kHz</p> <p>CF Step: 3000000 MHz</p> <p>Occupied Bandwidth: 17.665 MHz Total Power: 20.8 dBm</p> <p>Transmit Freq Error: -29.651 kHz OBW Power: 99.00 % x dB Bandwidth: 17.61 MHz x dB: -6.00 dB</p>
<p>5825MHz</p>	<p>5825MHz</p>
<p>Center Freq 5.825000000 GHz Center Freq 5.825000000 GHz Trig: Free Run AvgHold: 10/10 Radio Stn: None Radio Device: BTS</p> <p>Ref Offset: 11 dB Ref: 20.00 dBm</p> <p>Center Freq: 5.825 GHz Res BW: 100 kHz Span: 30 MHz Sweep: 2.933 ms #VBW: 300 kHz</p> <p>CF Step: 3000000 MHz</p> <p>Occupied Bandwidth: 16.448 MHz Total Power: 20.4 dBm</p> <p>Transmit Freq Error: -26.767 kHz OBW Power: 99.00 % x dB Bandwidth: 16.37 MHz x dB: -6.00 dB</p>	<p>Center Freq 5.825000000 GHz Center Freq 5.825000000 GHz Trig: Free Run AvgHold: 10/10 Radio Stn: None Radio Device: BTS</p> <p>Ref Offset: 11 dB Ref: 20.00 dBm</p> <p>Center Freq: 5.825 GHz Res BW: 100 kHz Span: 30 MHz Sweep: 2.933 ms #VBW: 300 kHz</p> <p>CF Step: 3000000 MHz</p> <p>Occupied Bandwidth: 17.627 MHz Total Power: 20.2 dBm</p> <p>Transmit Freq Error: -33.648 kHz OBW Power: 99.00 % x dB Bandwidth: 17.59 MHz x dB: -6.00 dB</p>

<p>11n HT40 5755MHz</p> <p>Center Freq 5.75500000 GHz</p> <p>Center Freq 5.75500000 GHz</p> <p>Ref Offset 11 dB Ref 20.00 dBm</p> <p>Center Freq 5.755 GHz</p> <p>Span 60 MHz</p> <p>Res BW 100 kHz</p> <p>#VBW 300 kHz</p> <p>Sweep 5.8 ms</p> <p>Occupied Bandwidth 36.136 MHz</p> <p>Total Power 20.2 dBm</p> <p>Transmit Freq Error -34.659 kHz</p> <p>OBW Power 99.00 %</p> <p>x dB Bandwidth 36.32 MHz</p> <p>x dB -6.00 dB</p>	<p>5785MHz</p> <p>Center Freq 5.78500000 GHz</p> <p>Center Freq 5.78500000 GHz</p> <p>Ref Offset 11 dB Ref 20.00 dBm</p> <p>Center Freq 5.785 GHz</p> <p>Span 30 MHz</p> <p>Res BW 100 kHz</p> <p>#VBW 300 kHz</p> <p>Sweep 2.933 ms</p> <p>Occupied Bandwidth 17.654 MHz</p> <p>Total Power 20.1 dBm</p> <p>Transmit Freq Error -29.156 kHz</p> <p>OBW Power 99.00 %</p> <p>x dB Bandwidth 17.60 MHz</p> <p>x dB -6.00 dB</p>
<p>5795MHz</p> <p>Center Freq 5.79500000 GHz</p> <p>Center Freq 5.79500000 GHz</p> <p>Ref Offset 11 dB Ref 20.00 dBm</p> <p>Center Freq 5.795 GHz</p> <p>Span 60 MHz</p> <p>Res BW 100 kHz</p> <p>#VBW 300 kHz</p> <p>Sweep 5.8 ms</p> <p>Occupied Bandwidth 36.111 MHz</p> <p>Total Power 20.0 dBm</p> <p>Transmit Freq Error -65.778 kHz</p> <p>OBW Power 99.00 %</p> <p>x dB Bandwidth 36.10 MHz</p> <p>x dB -6.00 dB</p>	<p>5825MHz</p> <p>Center Freq 5.82500000 GHz</p> <p>Center Freq 5.82500000 GHz</p> <p>Ref Offset 11 dB Ref 20.00 dBm</p> <p>Center Freq 5.825 GHz</p> <p>Span 30 MHz</p> <p>Res BW 100 kHz</p> <p>#VBW 300 kHz</p> <p>Sweep 2.933 ms</p> <p>Occupied Bandwidth 17.642 MHz</p> <p>Total Power 19.7 dBm</p> <p>Transmit Freq Error -40.408 kHz</p> <p>OBW Power 99.00 %</p> <p>x dB Bandwidth 17.61 MHz</p> <p>x dB -6.00 dB</p>
<p>11ac VHT20 5745MHz</p> <p>Center Freq 5.74500000 GHz</p> <p>Center Freq 5.74500000 GHz</p> <p>Ref Offset 11 dB Ref 20.00 dBm</p> <p>Center Freq 5.745 GHz</p> <p>Span 30 MHz</p> <p>Res BW 100 kHz</p> <p>#VBW 300 kHz</p> <p>Sweep 2.933 ms</p> <p>Occupied Bandwidth 17.678 MHz</p> <p>Total Power 19.1 dBm</p> <p>Transmit Freq Error -40.722 kHz</p> <p>OBW Power 99.00 %</p> <p>x dB Bandwidth 17.66 MHz</p> <p>x dB -6.00 dB</p>	<p>11ac VHT40 5755MHz</p> <p>Center Freq 5.75500000 GHz</p> <p>Center Freq 5.75500000 GHz</p> <p>Ref Offset 11 dB Ref 20.00 dBm</p> <p>Center Freq 5.755 GHz</p> <p>Span 60 MHz</p> <p>Res BW 100 kHz</p> <p>#VBW 300 kHz</p> <p>Sweep 5.8 ms</p> <p>Occupied Bandwidth 36.134 MHz</p> <p>Total Power 20.2 dBm</p> <p>Transmit Freq Error -33.560 kHz</p> <p>OBW Power 99.00 %</p> <p>x dB Bandwidth 36.33 MHz</p> <p>x dB -6.00 dB</p>

5795MHz

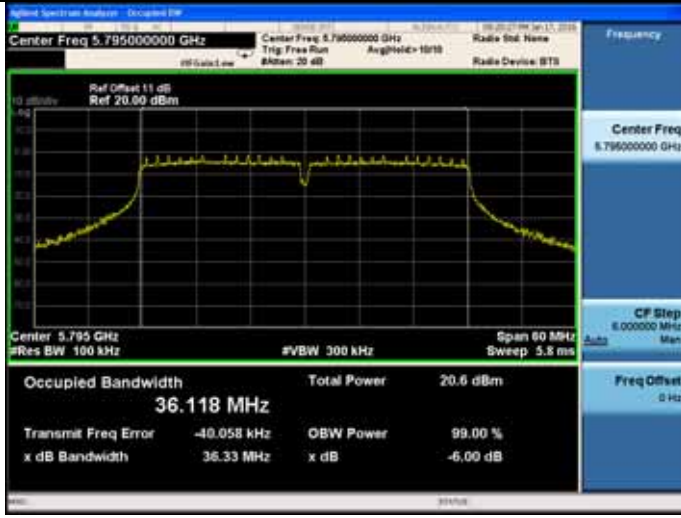

11ac VHT80
5775MHz

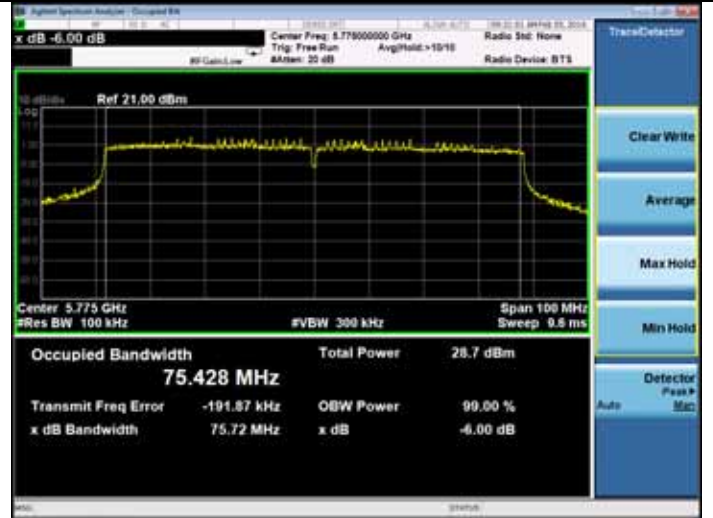

6dB bandwidth

ANT 2

11a

5745MHz



11n HT20

5745MHz

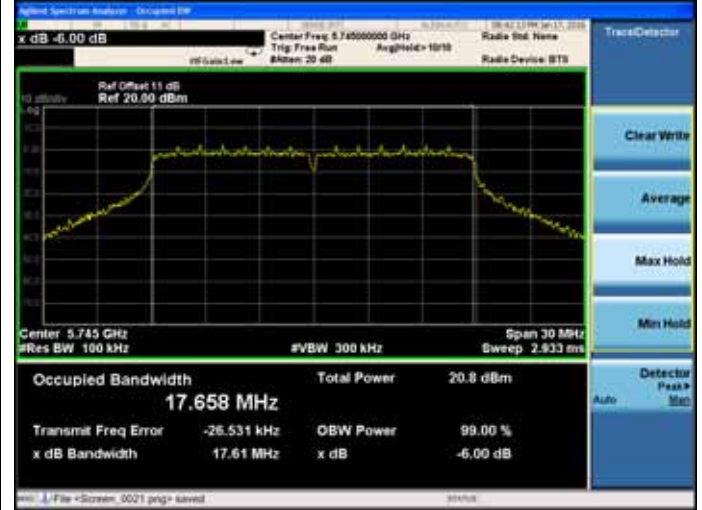

5785MHz

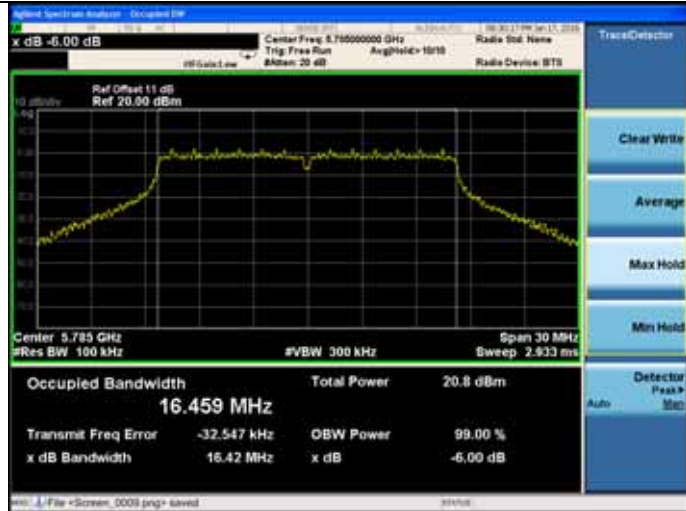

5785MHz

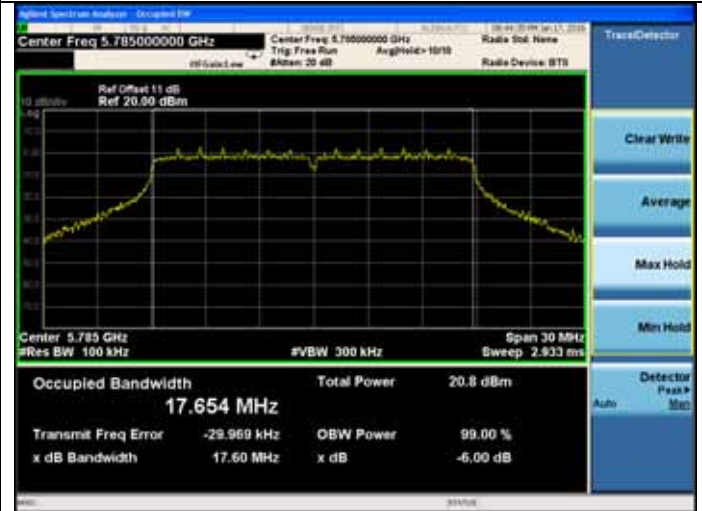

5825MHz



5825MHz

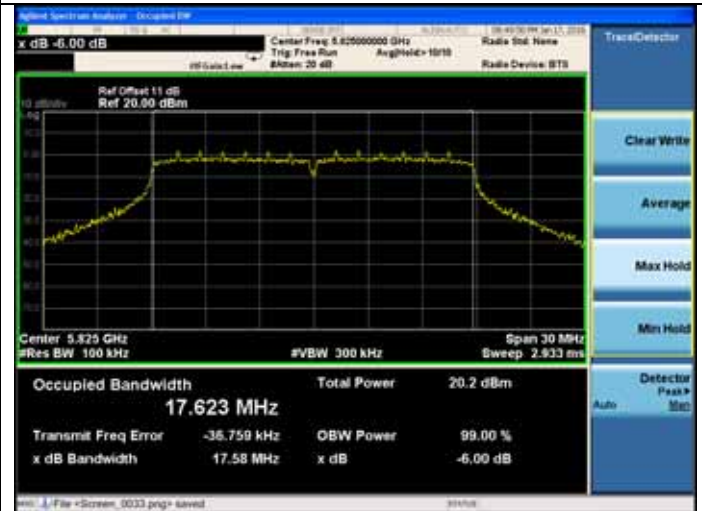

11n HT40

5755MHz

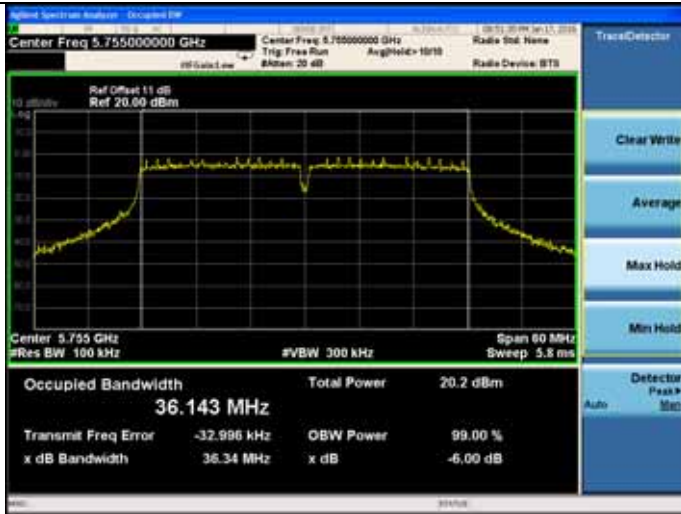

5785MHz

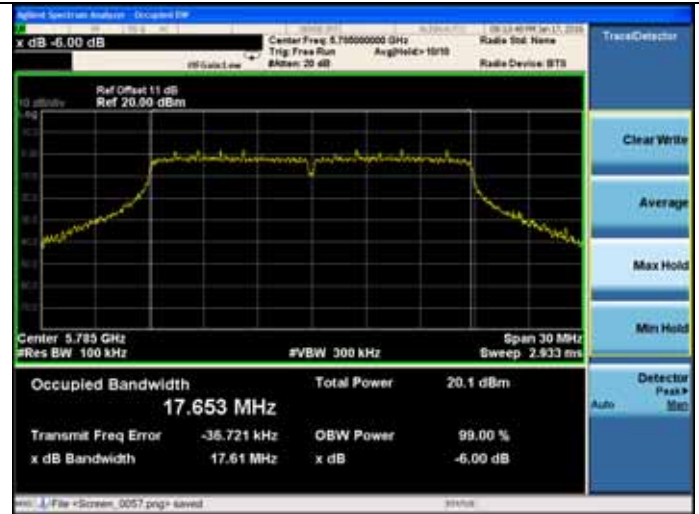

5795MHz

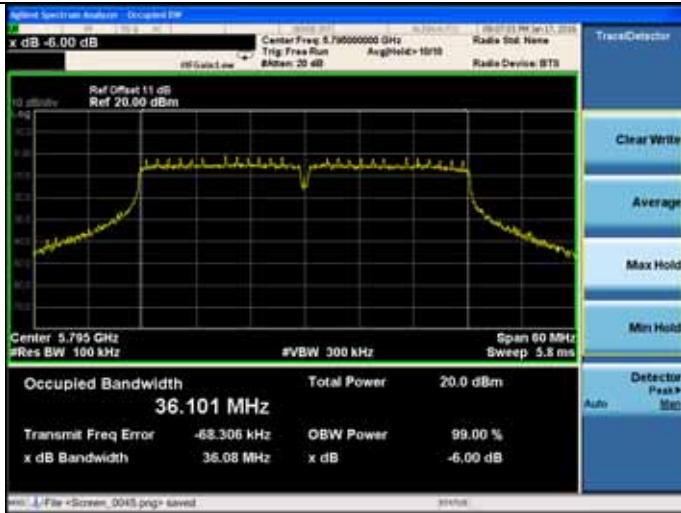

5825MHz



11ac VHT20

5745MHz

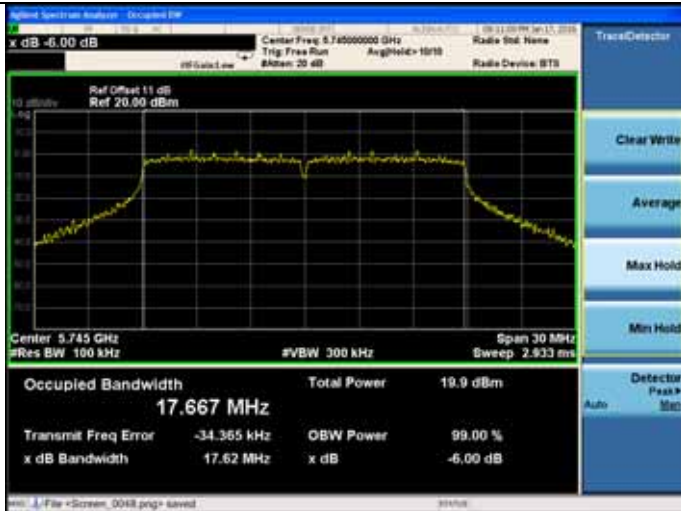

11ac VHT40

5755MHz

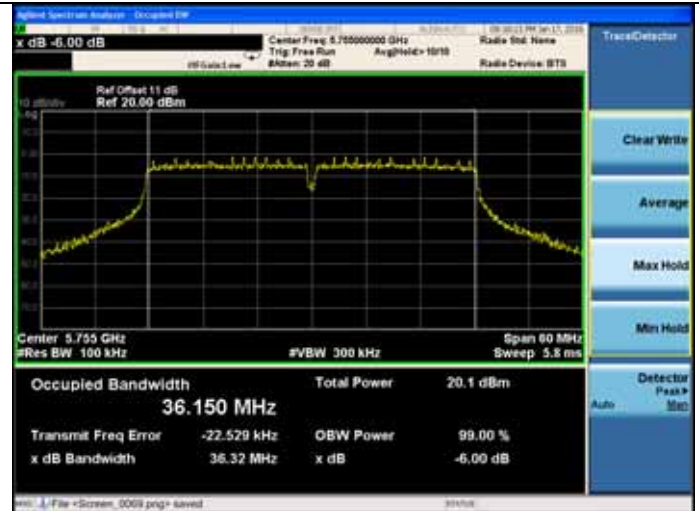

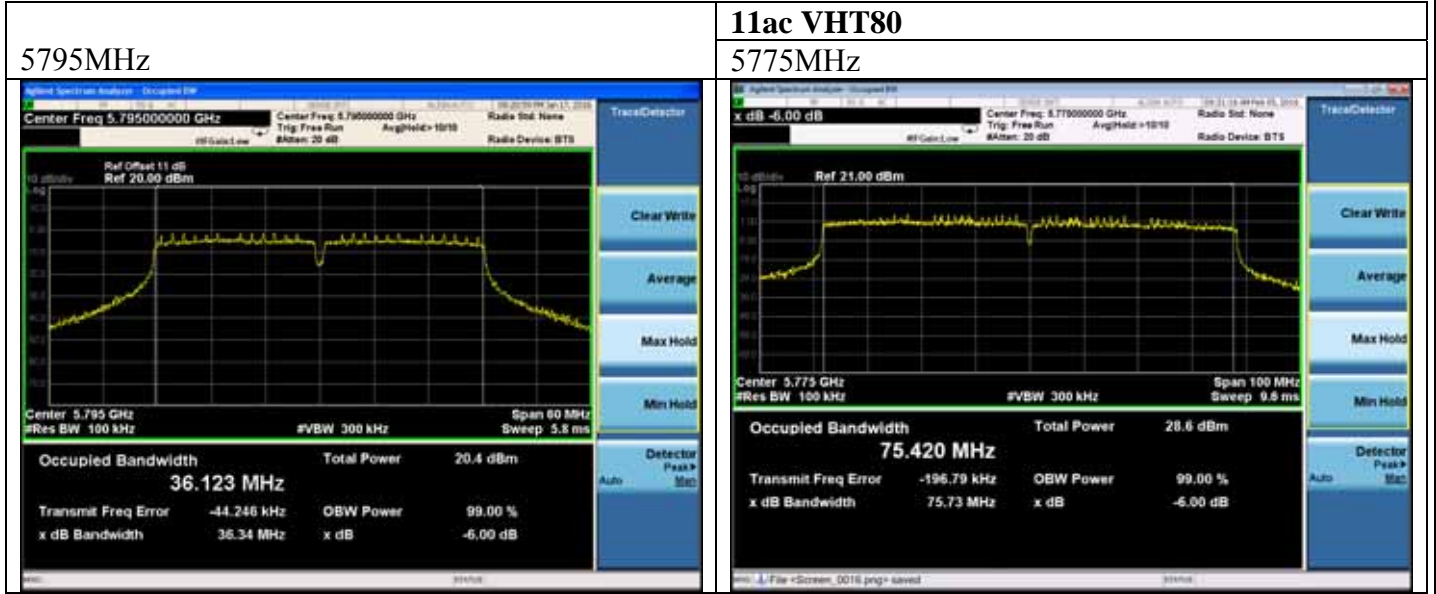

<p>6dB bandwidth</p>	
<p>ANT 3</p>	
<p>11a</p>	<p>11n HT20</p>
<p>5745MHz</p>	<p>5745MHz</p>
<p>Center Freq 5.745000000 GHz Center Freq 5.745000000 GHz Trig: Free Run AvgHold: 10/10 Radio Stn: None Radio Device: BTS</p> <p>Ref Offset: 11 dB Ref: 20.00 dBm</p> <p>Center: 5.745 GHz Res BW: 100 kHz Span: 30 MHz Sweep: 2.933 ms</p> <p>Occupied Bandwidth: 16.459 MHz Total Power: 20.4 dBm</p> <p>Transmit Freq Error: -15.898 kHz OBW Power: 99.00 % x dB Bandwidth: 16.39 MHz x dB: -6.00 dB</p>	<p>Center Freq 5.745000000 GHz Center Freq 5.745000000 GHz Trig: Free Run AvgHold: 10/10 Radio Stn: None Radio Device: BTS</p> <p>Ref Offset: 11 dB Ref: 20.00 dBm</p> <p>Center: 5.745 GHz Res BW: 100 kHz Span: 30 MHz Sweep: 2.933 ms</p> <p>Occupied Bandwidth: 17.664 MHz Total Power: 20.6 dBm</p> <p>Transmit Freq Error: -27.765 kHz OBW Power: 99.00 % x dB Bandwidth: 17.62 MHz x dB: -6.00 dB</p>
<p>5785MHz</p>	<p>5785MHz</p>
<p>Center Freq 5.785000000 GHz Center Freq 5.785000000 GHz Trig: Free Run AvgHold: 10/10 Radio Stn: None Radio Device: BTS</p> <p>Ref Offset: 11 dB Ref: 20.00 dBm</p> <p>Center: 5.785 GHz Res BW: 100 kHz Span: 30 MHz Sweep: 2.933 ms</p> <p>Occupied Bandwidth: 16.449 MHz Total Power: 20.7 dBm</p> <p>Transmit Freq Error: -35.778 kHz OBW Power: 99.00 % x dB Bandwidth: 16.40 MHz x dB: -6.00 dB</p>	<p>Center Freq 5.785000000 GHz Center Freq 5.785000000 GHz Trig: Free Run AvgHold: 10/10 Radio Stn: None Radio Device: BTS</p> <p>Ref Offset: 11 dB Ref: 20.00 dBm</p> <p>Center: 5.785 GHz Res BW: 100 kHz Span: 30 MHz Sweep: 2.933 ms</p> <p>Occupied Bandwidth: 17.651 MHz Total Power: 20.8 dBm</p> <p>Transmit Freq Error: -28.456 kHz OBW Power: 99.00 % x dB Bandwidth: 17.60 MHz x dB: -6.00 dB</p>
<p>5825MHz</p>	<p>5825MHz</p>
<p>Center Freq 5.825000000 GHz Center Freq 5.825000000 GHz Trig: Free Run AvgHold: 10/10 Radio Stn: None Radio Device: BTS</p> <p>Ref Offset: 11 dB Ref: 20.00 dBm</p> <p>Center: 5.825 GHz Res BW: 100 kHz Span: 30 MHz Sweep: 2.933 ms</p> <p>Occupied Bandwidth: 16.445 MHz Total Power: 19.9 dBm</p> <p>Transmit Freq Error: -29.193 kHz OBW Power: 99.00 % x dB Bandwidth: 16.37 MHz x dB: -6.00 dB</p>	<p>Center Freq 5.825000000 GHz Center Freq 5.825000000 GHz Trig: Free Run AvgHold: 10/10 Radio Stn: None Radio Device: BTS</p> <p>Ref Offset: 11 dB Ref: 20.00 dBm</p> <p>Center: 5.825 GHz Res BW: 100 kHz Span: 30 MHz Sweep: 2.933 ms</p> <p>Occupied Bandwidth: 17.626 MHz Total Power: 20.1 dBm</p> <p>Transmit Freq Error: -40.519 kHz OBW Power: 99.00 % x dB Bandwidth: 17.60 MHz x dB: -6.00 dB</p>

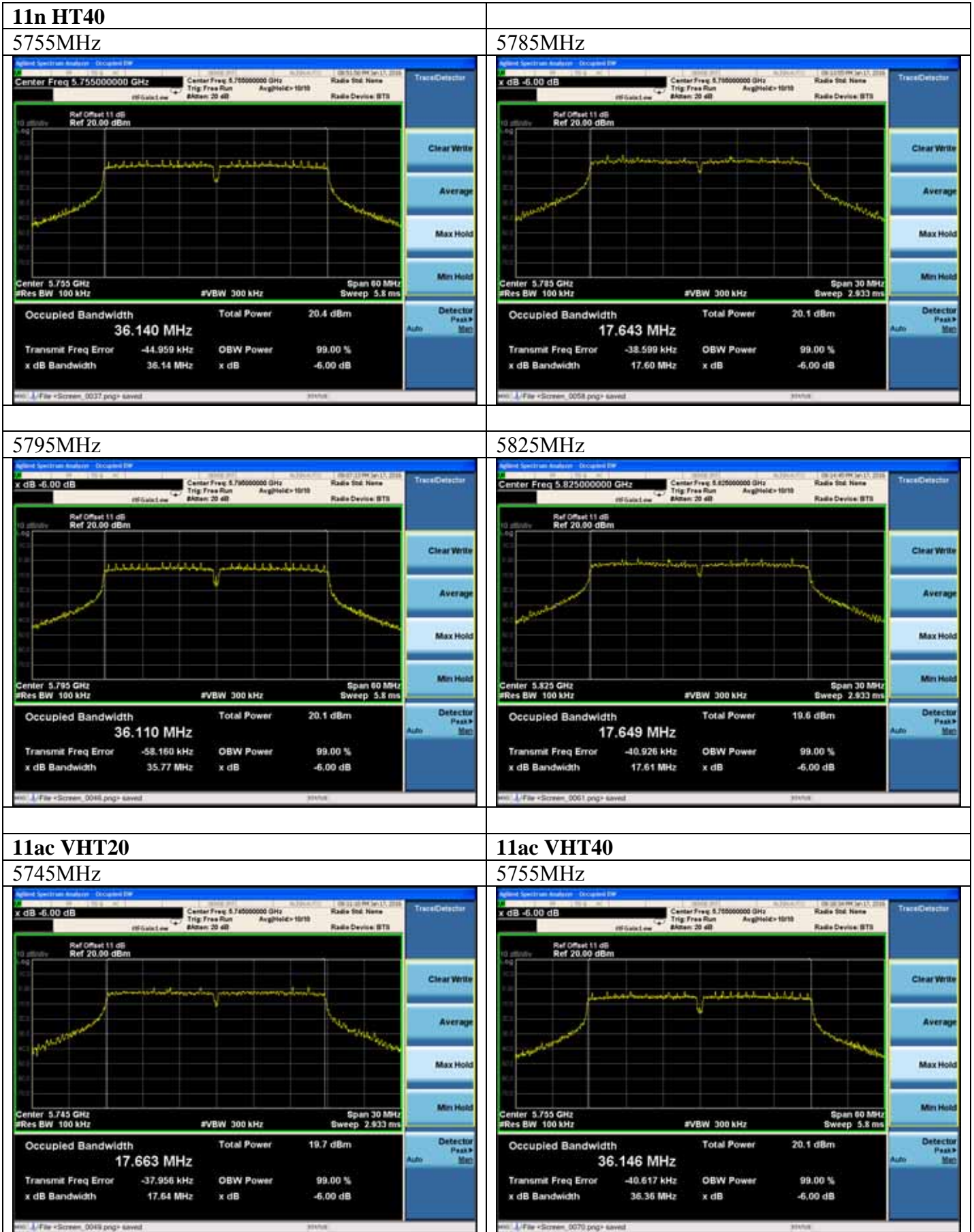

5795MHz

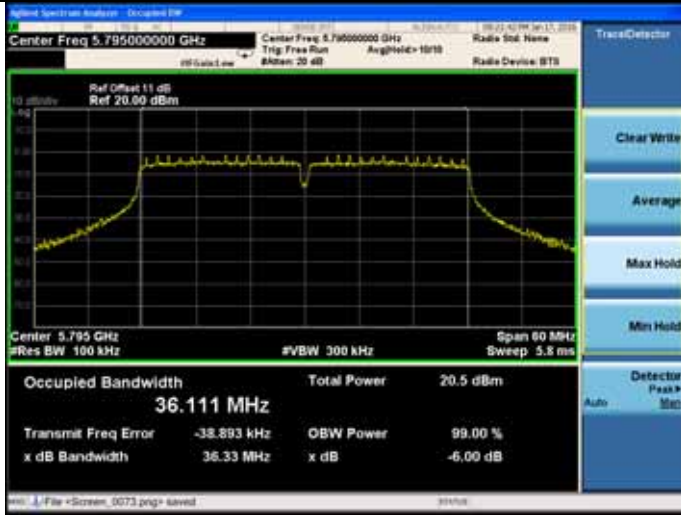

11ac VHT80
5775MHz

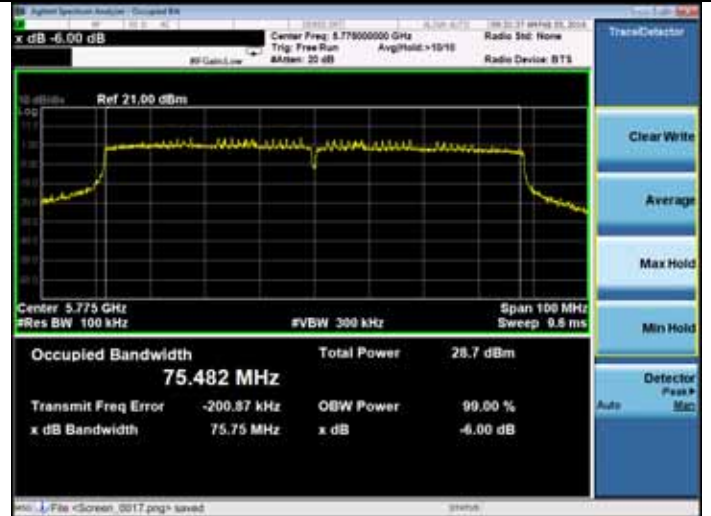

26dB bandwidth																																					
ANT 1																																					
11a	11n HT20																																				
5745MHz	5745MHz																																				
<p>Center Freq 5.745 GHz #Res BW 100 kHz #VBW 300 kHz Span 30 MHz Sweep 2.933 ms</p> <table border="1"> <tr> <td>Occupied Bandwidth</td> <td>Total Power</td> <td>20.2 dBm</td> </tr> <tr> <td>16.461 MHz</td> <td></td> <td></td> </tr> <tr> <td>Transmit Freq Error</td> <td>OBW Power</td> <td>99.00 %</td> </tr> <tr> <td>-25.243 kHz</td> <td></td> <td></td> </tr> <tr> <td>x dB Bandwidth</td> <td>x dB</td> <td>-26.00 dB</td> </tr> <tr> <td>19.92 MHz</td> <td></td> <td></td> </tr> </table>	Occupied Bandwidth	Total Power	20.2 dBm	16.461 MHz			Transmit Freq Error	OBW Power	99.00 %	-25.243 kHz			x dB Bandwidth	x dB	-26.00 dB	19.92 MHz			<p>Center Freq 5.745 GHz #Res BW 100 kHz #VBW 300 kHz Span 30 MHz Sweep 2.933 ms</p> <table border="1"> <tr> <td>Occupied Bandwidth</td> <td>Total Power</td> <td>20.9 dBm</td> </tr> <tr> <td>17.674 MHz</td> <td></td> <td></td> </tr> <tr> <td>Transmit Freq Error</td> <td>OBW Power</td> <td>99.00 %</td> </tr> <tr> <td>-26.539 kHz</td> <td></td> <td></td> </tr> <tr> <td>x dB Bandwidth</td> <td>x dB</td> <td>-26.00 dB</td> </tr> <tr> <td>21.55 MHz</td> <td></td> <td></td> </tr> </table>	Occupied Bandwidth	Total Power	20.9 dBm	17.674 MHz			Transmit Freq Error	OBW Power	99.00 %	-26.539 kHz			x dB Bandwidth	x dB	-26.00 dB	21.55 MHz		
Occupied Bandwidth	Total Power	20.2 dBm																																			
16.461 MHz																																					
Transmit Freq Error	OBW Power	99.00 %																																			
-25.243 kHz																																					
x dB Bandwidth	x dB	-26.00 dB																																			
19.92 MHz																																					
Occupied Bandwidth	Total Power	20.9 dBm																																			
17.674 MHz																																					
Transmit Freq Error	OBW Power	99.00 %																																			
-26.539 kHz																																					
x dB Bandwidth	x dB	-26.00 dB																																			
21.55 MHz																																					
5785MHz	5785MHz																																				
<p>Center Freq 5.785 GHz #Res BW 100 kHz #VBW 300 kHz Span 30 MHz Sweep 2.933 ms</p> <table border="1"> <tr> <td>Occupied Bandwidth</td> <td>Total Power</td> <td>20.7 dBm</td> </tr> <tr> <td>16.463 MHz</td> <td></td> <td></td> </tr> <tr> <td>Transmit Freq Error</td> <td>OBW Power</td> <td>99.00 %</td> </tr> <tr> <td>-30.214 kHz</td> <td></td> <td></td> </tr> <tr> <td>x dB Bandwidth</td> <td>x dB</td> <td>-26.00 dB</td> </tr> <tr> <td>20.33 MHz</td> <td></td> <td></td> </tr> </table>	Occupied Bandwidth	Total Power	20.7 dBm	16.463 MHz			Transmit Freq Error	OBW Power	99.00 %	-30.214 kHz			x dB Bandwidth	x dB	-26.00 dB	20.33 MHz			<p>Center Freq 5.785 GHz #Res BW 100 kHz #VBW 300 kHz Span 30 MHz Sweep 2.933 ms</p> <table border="1"> <tr> <td>Occupied Bandwidth</td> <td>Total Power</td> <td>20.7 dBm</td> </tr> <tr> <td>17.655 MHz</td> <td></td> <td></td> </tr> <tr> <td>Transmit Freq Error</td> <td>OBW Power</td> <td>99.00 %</td> </tr> <tr> <td>-28.188 kHz</td> <td></td> <td></td> </tr> <tr> <td>x dB Bandwidth</td> <td>x dB</td> <td>-26.00 dB</td> </tr> <tr> <td>21.26 MHz</td> <td></td> <td></td> </tr> </table>	Occupied Bandwidth	Total Power	20.7 dBm	17.655 MHz			Transmit Freq Error	OBW Power	99.00 %	-28.188 kHz			x dB Bandwidth	x dB	-26.00 dB	21.26 MHz		
Occupied Bandwidth	Total Power	20.7 dBm																																			
16.463 MHz																																					
Transmit Freq Error	OBW Power	99.00 %																																			
-30.214 kHz																																					
x dB Bandwidth	x dB	-26.00 dB																																			
20.33 MHz																																					
Occupied Bandwidth	Total Power	20.7 dBm																																			
17.655 MHz																																					
Transmit Freq Error	OBW Power	99.00 %																																			
-28.188 kHz																																					
x dB Bandwidth	x dB	-26.00 dB																																			
21.26 MHz																																					
5825MHz	5825MHz																																				
<p>Center Freq 5.825 GHz #Res BW 100 kHz #VBW 300 kHz Span 30 MHz Sweep 2.933 ms</p> <table border="1"> <tr> <td>Occupied Bandwidth</td> <td>Total Power</td> <td>19.9 dBm</td> </tr> <tr> <td>16.446 MHz</td> <td></td> <td></td> </tr> <tr> <td>Transmit Freq Error</td> <td>OBW Power</td> <td>99.00 %</td> </tr> <tr> <td>-27.529 kHz</td> <td></td> <td></td> </tr> <tr> <td>x dB Bandwidth</td> <td>x dB</td> <td>-26.00 dB</td> </tr> <tr> <td>20.15 MHz</td> <td></td> <td></td> </tr> </table>	Occupied Bandwidth	Total Power	19.9 dBm	16.446 MHz			Transmit Freq Error	OBW Power	99.00 %	-27.529 kHz			x dB Bandwidth	x dB	-26.00 dB	20.15 MHz			<p>Center Freq 5.825 GHz #Res BW 100 kHz #VBW 300 kHz Span 30 MHz Sweep 2.933 ms</p> <table border="1"> <tr> <td>Occupied Bandwidth</td> <td>Total Power</td> <td>20.0 dBm</td> </tr> <tr> <td>17.619 MHz</td> <td></td> <td></td> </tr> <tr> <td>Transmit Freq Error</td> <td>OBW Power</td> <td>99.00 %</td> </tr> <tr> <td>-36.895 kHz</td> <td></td> <td></td> </tr> <tr> <td>x dB Bandwidth</td> <td>x dB</td> <td>-26.00 dB</td> </tr> <tr> <td>20.80 MHz</td> <td></td> <td></td> </tr> </table>	Occupied Bandwidth	Total Power	20.0 dBm	17.619 MHz			Transmit Freq Error	OBW Power	99.00 %	-36.895 kHz			x dB Bandwidth	x dB	-26.00 dB	20.80 MHz		
Occupied Bandwidth	Total Power	19.9 dBm																																			
16.446 MHz																																					
Transmit Freq Error	OBW Power	99.00 %																																			
-27.529 kHz																																					
x dB Bandwidth	x dB	-26.00 dB																																			
20.15 MHz																																					
Occupied Bandwidth	Total Power	20.0 dBm																																			
17.619 MHz																																					
Transmit Freq Error	OBW Power	99.00 %																																			
-36.895 kHz																																					
x dB Bandwidth	x dB	-26.00 dB																																			
20.80 MHz																																					

<p>11n HT40 5755MHz</p> <p>Center Freq 5.755 GHz #Res BW 100 kHz #VBW 300 kHz Span 60 MHz Sweep 5.8 ms</p> <table border="1"> <tr> <td>Occupied Bandwidth</td> <td>Total Power</td> <td>20.3 dBm</td> </tr> <tr> <td>36.114 MHz</td> <td></td> <td></td> </tr> <tr> <td>Transmit Freq Error</td> <td>OBW Power</td> <td>99.00 %</td> </tr> <tr> <td>-41.938 kHz</td> <td>x dB</td> <td>-26.00 dB</td> </tr> <tr> <td>x dB Bandwidth</td> <td></td> <td></td> </tr> <tr> <td>40.43 MHz</td> <td></td> <td></td> </tr> </table>	Occupied Bandwidth	Total Power	20.3 dBm	36.114 MHz			Transmit Freq Error	OBW Power	99.00 %	-41.938 kHz	x dB	-26.00 dB	x dB Bandwidth			40.43 MHz			<p>5785MHz</p> <p>Center Freq 5.785 GHz #Res BW 100 kHz #VBW 300 kHz Span 30 MHz Sweep 2.933 ms</p> <table border="1"> <tr> <td>Occupied Bandwidth</td> <td>Total Power</td> <td>20.0 dBm</td> </tr> <tr> <td>17.647 MHz</td> <td></td> <td></td> </tr> <tr> <td>Transmit Freq Error</td> <td>OBW Power</td> <td>99.00 %</td> </tr> <tr> <td>-34.298 kHz</td> <td>x dB</td> <td>-26.00 dB</td> </tr> <tr> <td>x dB Bandwidth</td> <td></td> <td></td> </tr> <tr> <td>20.85 MHz</td> <td></td> <td></td> </tr> </table>	Occupied Bandwidth	Total Power	20.0 dBm	17.647 MHz			Transmit Freq Error	OBW Power	99.00 %	-34.298 kHz	x dB	-26.00 dB	x dB Bandwidth			20.85 MHz		
Occupied Bandwidth	Total Power	20.3 dBm																																			
36.114 MHz																																					
Transmit Freq Error	OBW Power	99.00 %																																			
-41.938 kHz	x dB	-26.00 dB																																			
x dB Bandwidth																																					
40.43 MHz																																					
Occupied Bandwidth	Total Power	20.0 dBm																																			
17.647 MHz																																					
Transmit Freq Error	OBW Power	99.00 %																																			
-34.298 kHz	x dB	-26.00 dB																																			
x dB Bandwidth																																					
20.85 MHz																																					
<p>5795MHz</p> <p>Center Freq 5.795 GHz #Res BW 100 kHz #VBW 300 kHz Span 60 MHz Sweep 5.8 ms</p> <table border="1"> <tr> <td>Occupied Bandwidth</td> <td>Total Power</td> <td>19.9 dBm</td> </tr> <tr> <td>36.093 MHz</td> <td></td> <td></td> </tr> <tr> <td>Transmit Freq Error</td> <td>OBW Power</td> <td>99.00 %</td> </tr> <tr> <td>-61.904 kHz</td> <td>x dB</td> <td>-26.00 dB</td> </tr> <tr> <td>x dB Bandwidth</td> <td></td> <td></td> </tr> <tr> <td>40.15 MHz</td> <td></td> <td></td> </tr> </table>	Occupied Bandwidth	Total Power	19.9 dBm	36.093 MHz			Transmit Freq Error	OBW Power	99.00 %	-61.904 kHz	x dB	-26.00 dB	x dB Bandwidth			40.15 MHz			<p>5825MHz</p> <p>Center Freq 5.825 GHz #Res BW 100 kHz #VBW 300 kHz Span 30 MHz Sweep 2.933 ms</p> <table border="1"> <tr> <td>Occupied Bandwidth</td> <td>Total Power</td> <td>19.7 dBm</td> </tr> <tr> <td>17.650 MHz</td> <td></td> <td></td> </tr> <tr> <td>Transmit Freq Error</td> <td>OBW Power</td> <td>99.00 %</td> </tr> <tr> <td>-44.338 kHz</td> <td>x dB</td> <td>-26.00 dB</td> </tr> <tr> <td>x dB Bandwidth</td> <td></td> <td></td> </tr> <tr> <td>20.87 MHz</td> <td></td> <td></td> </tr> </table>	Occupied Bandwidth	Total Power	19.7 dBm	17.650 MHz			Transmit Freq Error	OBW Power	99.00 %	-44.338 kHz	x dB	-26.00 dB	x dB Bandwidth			20.87 MHz		
Occupied Bandwidth	Total Power	19.9 dBm																																			
36.093 MHz																																					
Transmit Freq Error	OBW Power	99.00 %																																			
-61.904 kHz	x dB	-26.00 dB																																			
x dB Bandwidth																																					
40.15 MHz																																					
Occupied Bandwidth	Total Power	19.7 dBm																																			
17.650 MHz																																					
Transmit Freq Error	OBW Power	99.00 %																																			
-44.338 kHz	x dB	-26.00 dB																																			
x dB Bandwidth																																					
20.87 MHz																																					
<p>11ac VHT20 5745MHz</p> <p>Center Freq 5.745 GHz #Res BW 100 kHz #VBW 300 kHz Span 30 MHz Sweep 2.933 ms</p> <table border="1"> <tr> <td>Occupied Bandwidth</td> <td>Total Power</td> <td>19.7 dBm</td> </tr> <tr> <td>17.672 MHz</td> <td></td> <td></td> </tr> <tr> <td>Transmit Freq Error</td> <td>OBW Power</td> <td>99.00 %</td> </tr> <tr> <td>-34.436 kHz</td> <td>x dB</td> <td>-26.00 dB</td> </tr> <tr> <td>x dB Bandwidth</td> <td></td> <td></td> </tr> <tr> <td>21.14 MHz</td> <td></td> <td></td> </tr> </table>	Occupied Bandwidth	Total Power	19.7 dBm	17.672 MHz			Transmit Freq Error	OBW Power	99.00 %	-34.436 kHz	x dB	-26.00 dB	x dB Bandwidth			21.14 MHz			<p>11ac VHT40 5755MHz</p> <p>Center Freq 5.755 GHz #Res BW 100 kHz #VBW 300 kHz Span 60 MHz Sweep 5.8 ms</p> <table border="1"> <tr> <td>Occupied Bandwidth</td> <td>Total Power</td> <td>19.9 dBm</td> </tr> <tr> <td>36.149 MHz</td> <td></td> <td></td> </tr> <tr> <td>Transmit Freq Error</td> <td>OBW Power</td> <td>99.00 %</td> </tr> <tr> <td>-41.812 kHz</td> <td>x dB</td> <td>-26.00 dB</td> </tr> <tr> <td>x dB Bandwidth</td> <td></td> <td></td> </tr> <tr> <td>40.07 MHz</td> <td></td> <td></td> </tr> </table>	Occupied Bandwidth	Total Power	19.9 dBm	36.149 MHz			Transmit Freq Error	OBW Power	99.00 %	-41.812 kHz	x dB	-26.00 dB	x dB Bandwidth			40.07 MHz		
Occupied Bandwidth	Total Power	19.7 dBm																																			
17.672 MHz																																					
Transmit Freq Error	OBW Power	99.00 %																																			
-34.436 kHz	x dB	-26.00 dB																																			
x dB Bandwidth																																					
21.14 MHz																																					
Occupied Bandwidth	Total Power	19.9 dBm																																			
36.149 MHz																																					
Transmit Freq Error	OBW Power	99.00 %																																			
-41.812 kHz	x dB	-26.00 dB																																			
x dB Bandwidth																																					
40.07 MHz																																					

5795MHz

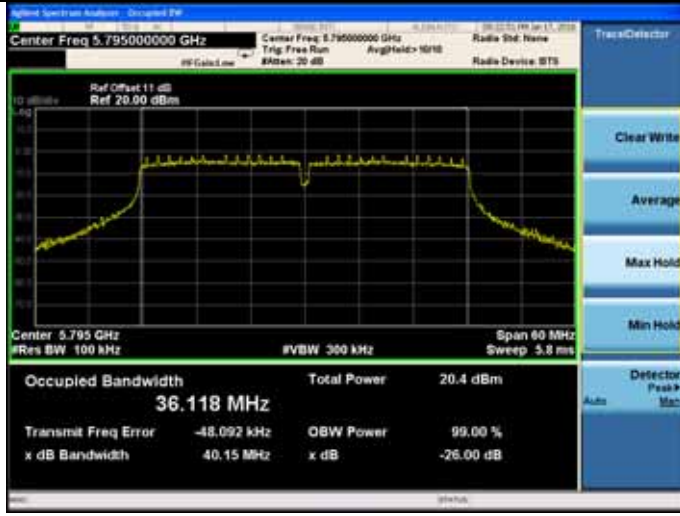

11ac VHT80
5775MHz

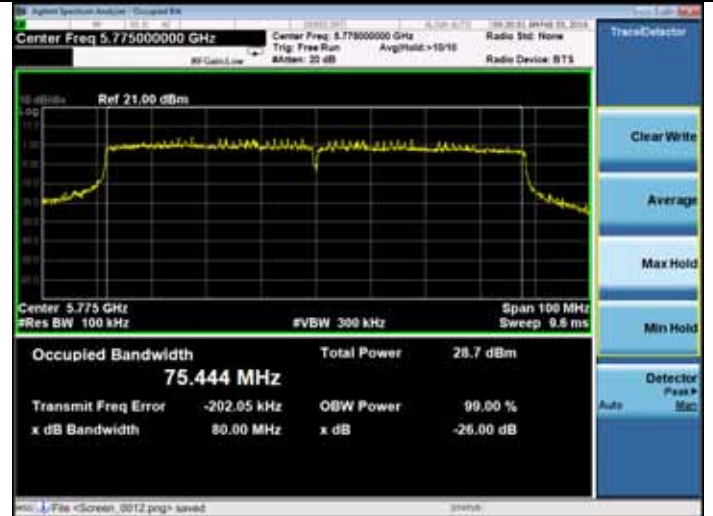

<p>26dB bandwidth</p> <p>ANT 2</p>																																					
<p>11a</p> <p>5745MHz</p> <table border="1"> <tr> <td>Occupied Bandwidth</td> <td>Total Power</td> <td>20.5 dBm</td> </tr> <tr> <td>16.455 MHz</td> <td></td> <td></td> </tr> <tr> <td>Transmit Freq Error</td> <td>OBW Power</td> <td>99.00 %</td> </tr> <tr> <td>-17.855 kHz</td> <td></td> <td></td> </tr> <tr> <td>x dB Bandwidth</td> <td>x dB</td> <td>-26.00 dB</td> </tr> <tr> <td>20.67 MHz</td> <td></td> <td></td> </tr> </table>	Occupied Bandwidth	Total Power	20.5 dBm	16.455 MHz			Transmit Freq Error	OBW Power	99.00 %	-17.855 kHz			x dB Bandwidth	x dB	-26.00 dB	20.67 MHz			<p>11n HT20</p> <p>5745MHz</p> <table border="1"> <tr> <td>Occupied Bandwidth</td> <td>Total Power</td> <td>20.7 dBm</td> </tr> <tr> <td>17.664 MHz</td> <td></td> <td></td> </tr> <tr> <td>Transmit Freq Error</td> <td>OBW Power</td> <td>99.00 %</td> </tr> <tr> <td>-31.567 kHz</td> <td></td> <td></td> </tr> <tr> <td>x dB Bandwidth</td> <td>x dB</td> <td>-26.00 dB</td> </tr> <tr> <td>21.09 MHz</td> <td></td> <td></td> </tr> </table>	Occupied Bandwidth	Total Power	20.7 dBm	17.664 MHz			Transmit Freq Error	OBW Power	99.00 %	-31.567 kHz			x dB Bandwidth	x dB	-26.00 dB	21.09 MHz		
Occupied Bandwidth	Total Power	20.5 dBm																																			
16.455 MHz																																					
Transmit Freq Error	OBW Power	99.00 %																																			
-17.855 kHz																																					
x dB Bandwidth	x dB	-26.00 dB																																			
20.67 MHz																																					
Occupied Bandwidth	Total Power	20.7 dBm																																			
17.664 MHz																																					
Transmit Freq Error	OBW Power	99.00 %																																			
-31.567 kHz																																					
x dB Bandwidth	x dB	-26.00 dB																																			
21.09 MHz																																					
<p>5785MHz</p> <table border="1"> <tr> <td>Occupied Bandwidth</td> <td>Total Power</td> <td>20.8 dBm</td> </tr> <tr> <td>16.467 MHz</td> <td></td> <td></td> </tr> <tr> <td>Transmit Freq Error</td> <td>OBW Power</td> <td>99.00 %</td> </tr> <tr> <td>-31.655 kHz</td> <td></td> <td></td> </tr> <tr> <td>x dB Bandwidth</td> <td>x dB</td> <td>-26.00 dB</td> </tr> <tr> <td>20.19 MHz</td> <td></td> <td></td> </tr> </table>	Occupied Bandwidth	Total Power	20.8 dBm	16.467 MHz			Transmit Freq Error	OBW Power	99.00 %	-31.655 kHz			x dB Bandwidth	x dB	-26.00 dB	20.19 MHz			<p>5785MHz</p> <table border="1"> <tr> <td>Occupied Bandwidth</td> <td>Total Power</td> <td>20.4 dBm</td> </tr> <tr> <td>17.648 MHz</td> <td></td> <td></td> </tr> <tr> <td>Transmit Freq Error</td> <td>OBW Power</td> <td>99.00 %</td> </tr> <tr> <td>-24.941 kHz</td> <td></td> <td></td> </tr> <tr> <td>x dB Bandwidth</td> <td>x dB</td> <td>-26.00 dB</td> </tr> <tr> <td>21.02 MHz</td> <td></td> <td></td> </tr> </table>	Occupied Bandwidth	Total Power	20.4 dBm	17.648 MHz			Transmit Freq Error	OBW Power	99.00 %	-24.941 kHz			x dB Bandwidth	x dB	-26.00 dB	21.02 MHz		
Occupied Bandwidth	Total Power	20.8 dBm																																			
16.467 MHz																																					
Transmit Freq Error	OBW Power	99.00 %																																			
-31.655 kHz																																					
x dB Bandwidth	x dB	-26.00 dB																																			
20.19 MHz																																					
Occupied Bandwidth	Total Power	20.4 dBm																																			
17.648 MHz																																					
Transmit Freq Error	OBW Power	99.00 %																																			
-24.941 kHz																																					
x dB Bandwidth	x dB	-26.00 dB																																			
21.02 MHz																																					
<p>5825MHz</p> <table border="1"> <tr> <td>Occupied Bandwidth</td> <td>Total Power</td> <td>20.2 dBm</td> </tr> <tr> <td>16.430 MHz</td> <td></td> <td></td> </tr> <tr> <td>Transmit Freq Error</td> <td>OBW Power</td> <td>99.00 %</td> </tr> <tr> <td>-25.626 kHz</td> <td></td> <td></td> </tr> <tr> <td>x dB Bandwidth</td> <td>x dB</td> <td>-26.00 dB</td> </tr> <tr> <td>20.69 MHz</td> <td></td> <td></td> </tr> </table>	Occupied Bandwidth	Total Power	20.2 dBm	16.430 MHz			Transmit Freq Error	OBW Power	99.00 %	-25.626 kHz			x dB Bandwidth	x dB	-26.00 dB	20.69 MHz			<p>5825MHz</p> <table border="1"> <tr> <td>Occupied Bandwidth</td> <td>Total Power</td> <td>20.4 dBm</td> </tr> <tr> <td>17.626 MHz</td> <td></td> <td></td> </tr> <tr> <td>Transmit Freq Error</td> <td>OBW Power</td> <td>99.00 %</td> </tr> <tr> <td>-39.929 kHz</td> <td></td> <td></td> </tr> <tr> <td>x dB Bandwidth</td> <td>x dB</td> <td>-26.00 dB</td> </tr> <tr> <td>20.91 MHz</td> <td></td> <td></td> </tr> </table>	Occupied Bandwidth	Total Power	20.4 dBm	17.626 MHz			Transmit Freq Error	OBW Power	99.00 %	-39.929 kHz			x dB Bandwidth	x dB	-26.00 dB	20.91 MHz		
Occupied Bandwidth	Total Power	20.2 dBm																																			
16.430 MHz																																					
Transmit Freq Error	OBW Power	99.00 %																																			
-25.626 kHz																																					
x dB Bandwidth	x dB	-26.00 dB																																			
20.69 MHz																																					
Occupied Bandwidth	Total Power	20.4 dBm																																			
17.626 MHz																																					
Transmit Freq Error	OBW Power	99.00 %																																			
-39.929 kHz																																					
x dB Bandwidth	x dB	-26.00 dB																																			
20.91 MHz																																					

11n HT40

5755MHz

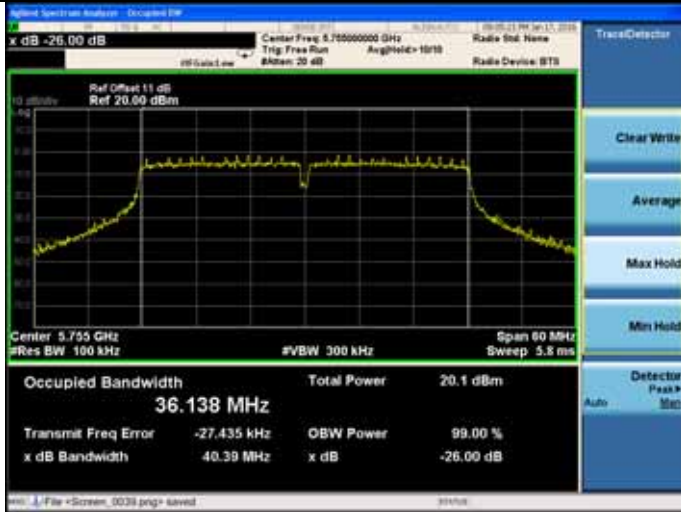

5785MHz

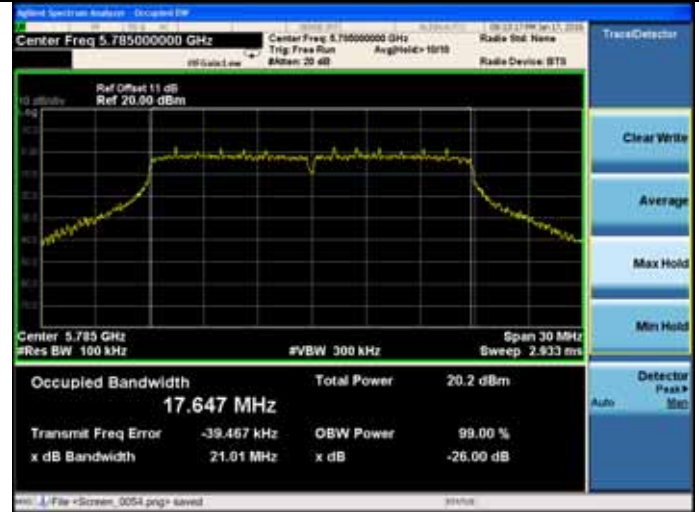

5795MHz

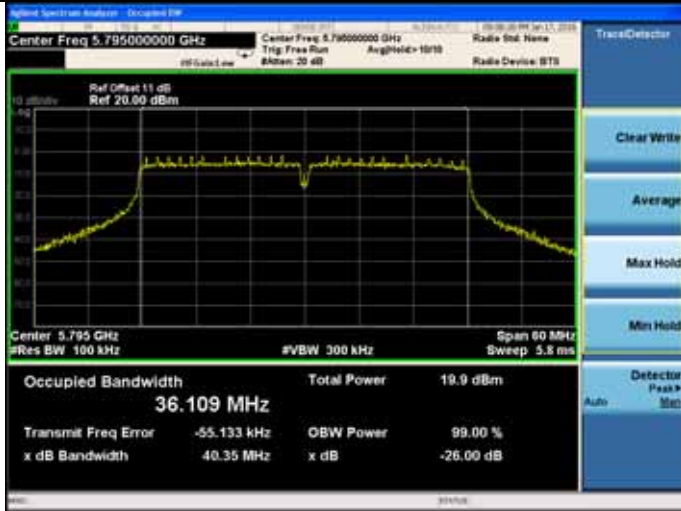

5825MHz



11ac VHT20

5745MHz

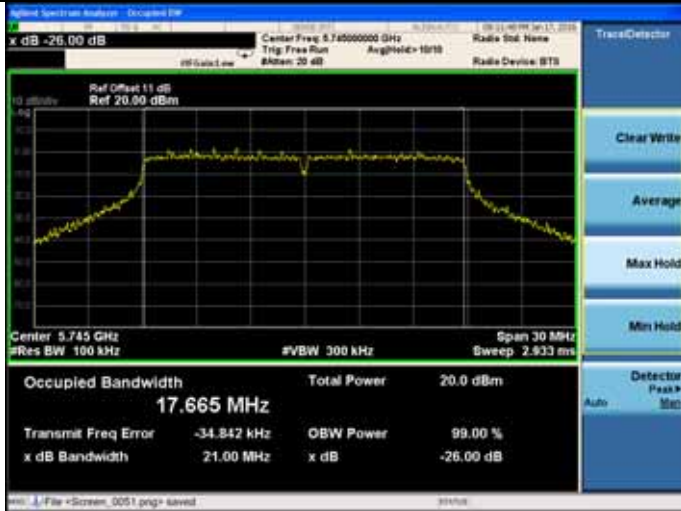

11ac VHT40

5755MHz

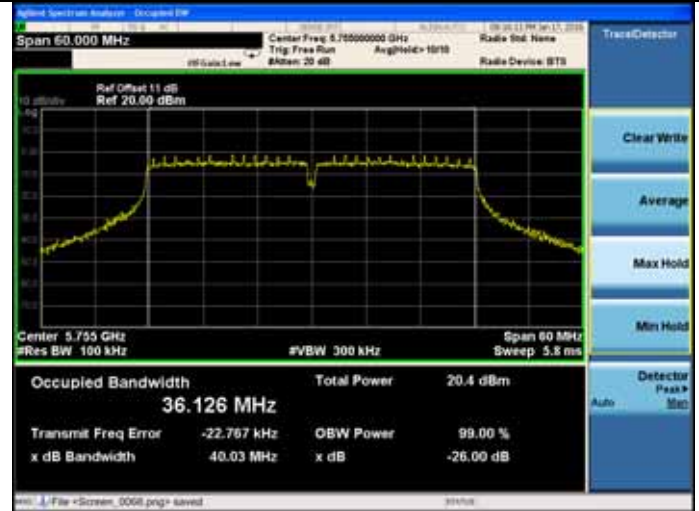

5795MHz

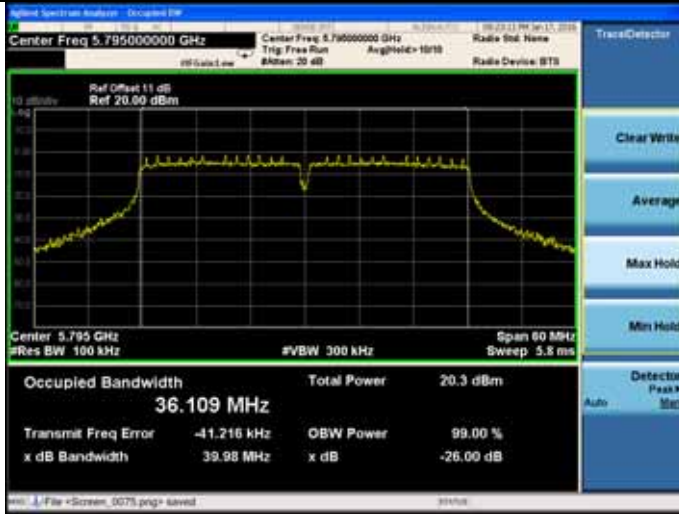

11ac VHT80

5775MHz



<p>26dB bandwidth</p> <p>ANT 3</p>																																					
<p>11a</p> <p>5745MHz</p> <table border="1"> <tr> <td>Occupied Bandwidth</td> <td>Total Power</td> <td>20.2 dBm</td> </tr> <tr> <td>16.456 MHz</td> <td></td> <td></td> </tr> <tr> <td>Transmit Freq Error</td> <td>OBW Power</td> <td>99.00 %</td> </tr> <tr> <td>-20.322 kHz</td> <td></td> <td></td> </tr> <tr> <td>x dB Bandwidth</td> <td>x dB</td> <td>-26.00 dB</td> </tr> <tr> <td>20.34 MHz</td> <td></td> <td></td> </tr> </table>	Occupied Bandwidth	Total Power	20.2 dBm	16.456 MHz			Transmit Freq Error	OBW Power	99.00 %	-20.322 kHz			x dB Bandwidth	x dB	-26.00 dB	20.34 MHz			<p>11n HT20</p> <p>5745MHz</p> <table border="1"> <tr> <td>Occupied Bandwidth</td> <td>Total Power</td> <td>20.8 dBm</td> </tr> <tr> <td>17.662 MHz</td> <td></td> <td></td> </tr> <tr> <td>Transmit Freq Error</td> <td>OBW Power</td> <td>99.00 %</td> </tr> <tr> <td>-27.316 kHz</td> <td></td> <td></td> </tr> <tr> <td>x dB Bandwidth</td> <td>x dB</td> <td>-26.00 dB</td> </tr> <tr> <td>21.22 MHz</td> <td></td> <td></td> </tr> </table>	Occupied Bandwidth	Total Power	20.8 dBm	17.662 MHz			Transmit Freq Error	OBW Power	99.00 %	-27.316 kHz			x dB Bandwidth	x dB	-26.00 dB	21.22 MHz		
Occupied Bandwidth	Total Power	20.2 dBm																																			
16.456 MHz																																					
Transmit Freq Error	OBW Power	99.00 %																																			
-20.322 kHz																																					
x dB Bandwidth	x dB	-26.00 dB																																			
20.34 MHz																																					
Occupied Bandwidth	Total Power	20.8 dBm																																			
17.662 MHz																																					
Transmit Freq Error	OBW Power	99.00 %																																			
-27.316 kHz																																					
x dB Bandwidth	x dB	-26.00 dB																																			
21.22 MHz																																					
<p>5785MHz</p> <table border="1"> <tr> <td>Occupied Bandwidth</td> <td>Total Power</td> <td>20.7 dBm</td> </tr> <tr> <td>16.454 MHz</td> <td></td> <td></td> </tr> <tr> <td>Transmit Freq Error</td> <td>OBW Power</td> <td>99.00 %</td> </tr> <tr> <td>-36.017 kHz</td> <td></td> <td></td> </tr> <tr> <td>x dB Bandwidth</td> <td>x dB</td> <td>-26.00 dB</td> </tr> <tr> <td>20.78 MHz</td> <td></td> <td></td> </tr> </table>	Occupied Bandwidth	Total Power	20.7 dBm	16.454 MHz			Transmit Freq Error	OBW Power	99.00 %	-36.017 kHz			x dB Bandwidth	x dB	-26.00 dB	20.78 MHz			<p>5785MHz</p> <table border="1"> <tr> <td>Occupied Bandwidth</td> <td>Total Power</td> <td>20.4 dBm</td> </tr> <tr> <td>17.668 MHz</td> <td></td> <td></td> </tr> <tr> <td>Transmit Freq Error</td> <td>OBW Power</td> <td>99.00 %</td> </tr> <tr> <td>-27.485 kHz</td> <td></td> <td></td> </tr> <tr> <td>x dB Bandwidth</td> <td>x dB</td> <td>-26.00 dB</td> </tr> <tr> <td>21.05 MHz</td> <td></td> <td></td> </tr> </table>	Occupied Bandwidth	Total Power	20.4 dBm	17.668 MHz			Transmit Freq Error	OBW Power	99.00 %	-27.485 kHz			x dB Bandwidth	x dB	-26.00 dB	21.05 MHz		
Occupied Bandwidth	Total Power	20.7 dBm																																			
16.454 MHz																																					
Transmit Freq Error	OBW Power	99.00 %																																			
-36.017 kHz																																					
x dB Bandwidth	x dB	-26.00 dB																																			
20.78 MHz																																					
Occupied Bandwidth	Total Power	20.4 dBm																																			
17.668 MHz																																					
Transmit Freq Error	OBW Power	99.00 %																																			
-27.485 kHz																																					
x dB Bandwidth	x dB	-26.00 dB																																			
21.05 MHz																																					
<p>5825MHz</p> <table border="1"> <tr> <td>Occupied Bandwidth</td> <td>Total Power</td> <td>20.3 dBm</td> </tr> <tr> <td>16.436 MHz</td> <td></td> <td></td> </tr> <tr> <td>Transmit Freq Error</td> <td>OBW Power</td> <td>99.00 %</td> </tr> <tr> <td>-27.381 kHz</td> <td></td> <td></td> </tr> <tr> <td>x dB Bandwidth</td> <td>x dB</td> <td>-26.00 dB</td> </tr> <tr> <td>19.96 MHz</td> <td></td> <td></td> </tr> </table>	Occupied Bandwidth	Total Power	20.3 dBm	16.436 MHz			Transmit Freq Error	OBW Power	99.00 %	-27.381 kHz			x dB Bandwidth	x dB	-26.00 dB	19.96 MHz			<p>5825MHz</p> <table border="1"> <tr> <td>Occupied Bandwidth</td> <td>Total Power</td> <td>20.5 dBm</td> </tr> <tr> <td>17.628 MHz</td> <td></td> <td></td> </tr> <tr> <td>Transmit Freq Error</td> <td>OBW Power</td> <td>99.00 %</td> </tr> <tr> <td>-35.809 kHz</td> <td></td> <td></td> </tr> <tr> <td>x dB Bandwidth</td> <td>x dB</td> <td>-26.00 dB</td> </tr> <tr> <td>21.19 MHz</td> <td></td> <td></td> </tr> </table>	Occupied Bandwidth	Total Power	20.5 dBm	17.628 MHz			Transmit Freq Error	OBW Power	99.00 %	-35.809 kHz			x dB Bandwidth	x dB	-26.00 dB	21.19 MHz		
Occupied Bandwidth	Total Power	20.3 dBm																																			
16.436 MHz																																					
Transmit Freq Error	OBW Power	99.00 %																																			
-27.381 kHz																																					
x dB Bandwidth	x dB	-26.00 dB																																			
19.96 MHz																																					
Occupied Bandwidth	Total Power	20.5 dBm																																			
17.628 MHz																																					
Transmit Freq Error	OBW Power	99.00 %																																			
-35.809 kHz																																					
x dB Bandwidth	x dB	-26.00 dB																																			
21.19 MHz																																					

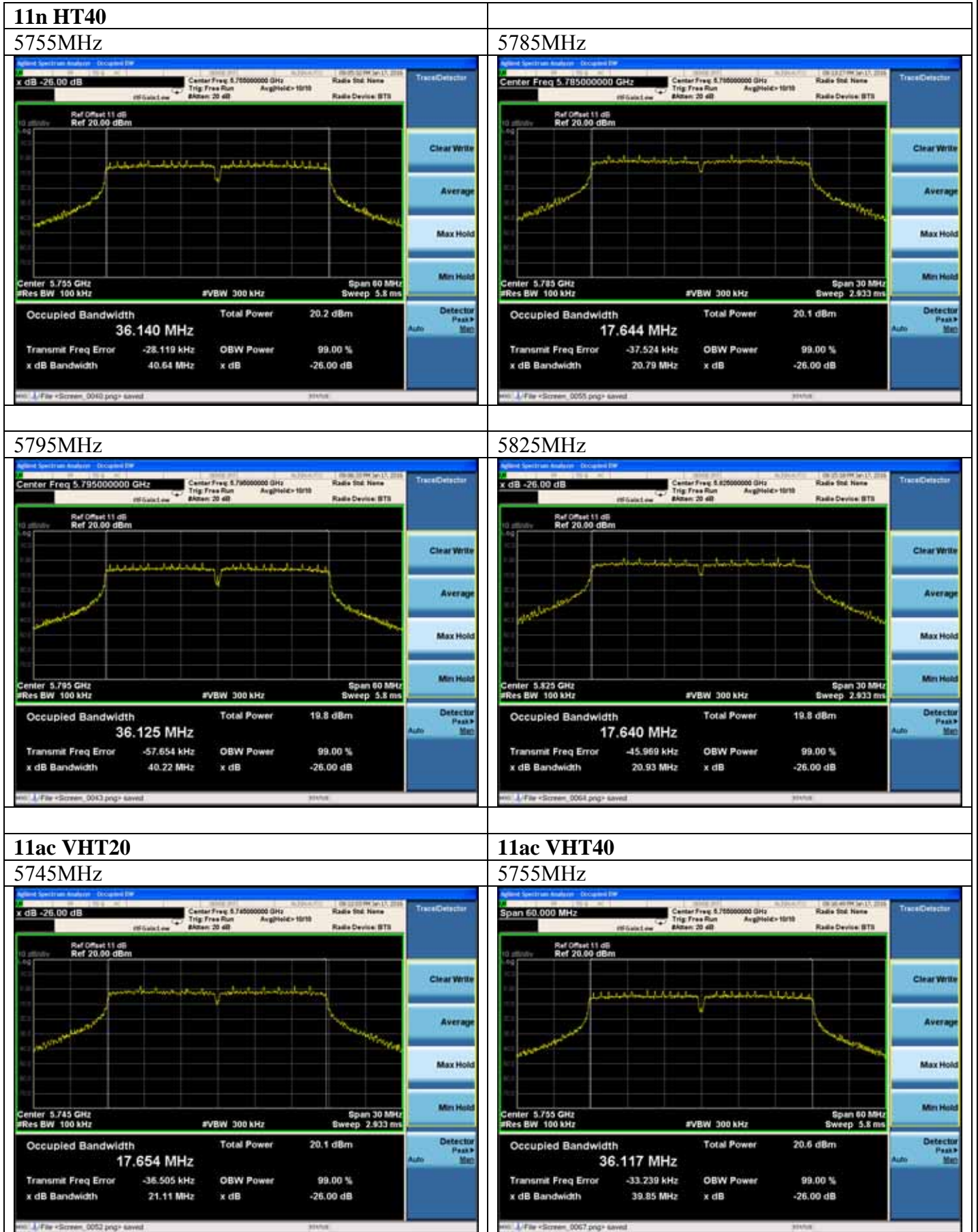

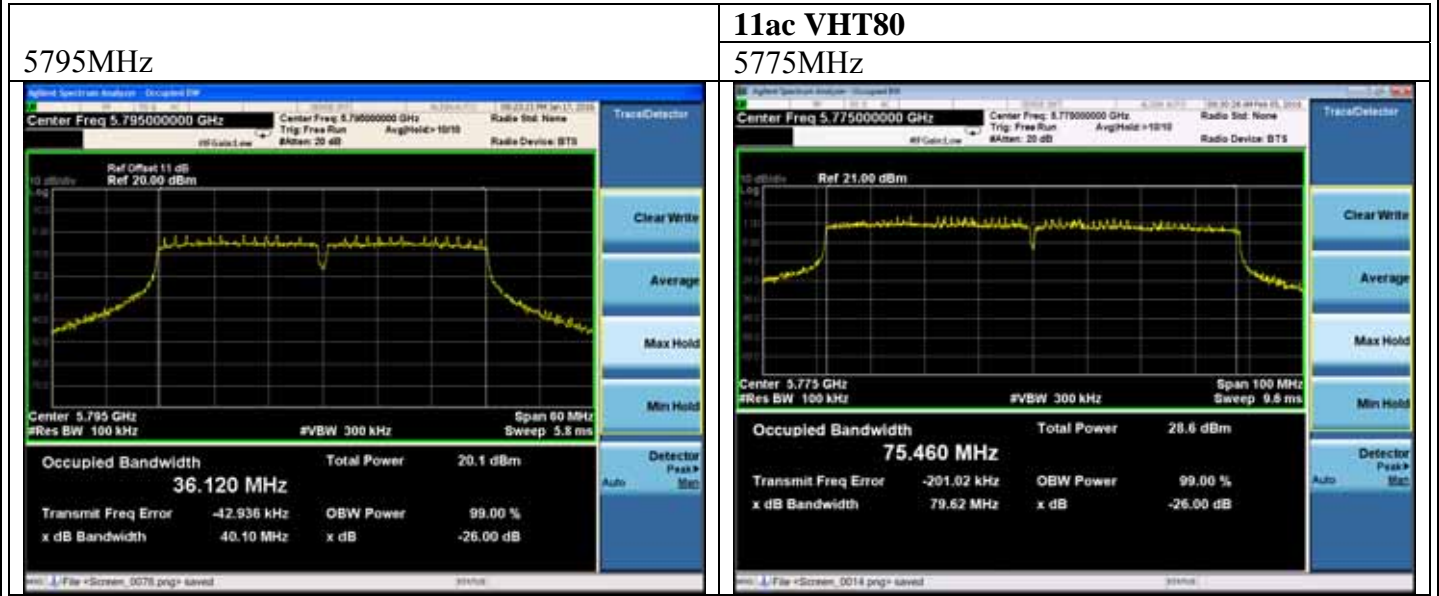

7. OUTPUT POWER TEST

7.1. Test Equipment

Item	Equipment	Manufacturer	Model No.	Serial No.	Last Cal.	Cal. Interval
1.	Spectrum	Agilent	N9030A	MY51380221	Oct.18,15	1 Year
2.	Power meter	Anritsu	ML2487A	6K00002472	Aug.21,15	1 Year
3.	Power sensor	Anritsu	MA2491A	0033005	Aug.21,15	1 Year
4.	Attenuator (20dB)	Agilent	8491B	MY39262165	Apr.28,15	1 Year
5.	RF Cable	Marvelous Microwave Inc	SFL402105FLEX	NO.1	Oct.17,15	1 Year

7.2. Limit

For the band 5.15–5.25 GHz.

For mobile and portable client devices in the 5.15–5.25 GHz band, the maximum conducted output power over the frequency band of operation shall not exceed 250 mW provided the maximum antenna gain does not exceed 6 dBi.

For the 5.25–5.35 GHz and 5.47–5.725 GHz bands, the maximum conducted output power over the frequency bands of operation shall not exceed the lesser of 250 mW or 11 dBm + 10 log B, where B is the 26 dB emission bandwidth in megahertz.

For the band 5.725-5.85 GHz, the maximum conducted output power over the frequency band of operation shall not exceed 1W.

7.3. Test Procedure

1. Connected the EUT’s antenna port to measure device by 26dB attenuator.
2. For IEEE 802.11a and IEEE802.11n HT20 and 802.11ac VHT20 mode, use a PK power meter which’s bandwidth is 20MHz and above 26dB bandwidth of signal to measure out each test modes’ PK output power.
3. For IEEE802.11n HT40 mode, because the signal’s bandwidth is about 40MHz and above 20MHz bandwidth of power sensor ML2491A. So use the test method described in KBD789033 clause E Method SA-1
 - 1) Connect the antenna port to the spectrum analyzer and Set span of the spectrum to encompass the entire emission bandwidth (EBW) of the signal.
 - 2) Set the RBW=1MHz and VBW =3MHz
 - 3) Number of points in sweep ≥ 2 Span / RBW
 - 4) Detector = RMS
 - 5) Sweep time = auto couple
 - 6) Allow the sweep to “free run” and set the Trace average at least 100 traces in power averaging (i.e., RMS) mode.
 - 7) Compute power by integrating the spectrum across the 26 dB EBW of the signal using the instrument’s band power measurement function with band limits set equal to the EBW band edges.

Note: The cable loss and attenuator loss were offset into measure device as an amplitude offset.

7.4. Test Results

EUT: Altai A3w Indoor Dual-band 3X3 802.11ac WiFi AP		
M/N: WA3311NAC-W		
Test date: 2016-02-05	Pressure: 102.2±1.0kPa	Humidity:51.9±3.0%
Tested by: Leo-Li	Test site: RF site	Temperature:23.5±0.6 °C

Test Mode	Frequency (MHz)	Maximum Conducted Output Power (dBm)				Limit (dBm)
		ANT 1	ANT 2	ANT 3	Total	
11a	5745	20.04	20.15	20.07	24.86	26
	5785	19.79	19.84	20.09	24.68	26
	5825	19.46	19.62	20.21	24.55	26
11n HT20	5745	19.77	19.75	19.41	24.42	26
	5785	19.89	19.74	19.92	24.62	26
	5825	19.21	19.48	19.92	24.32	26
11n HT40	5755	19.55	19.61	19.53	24.33	26
	5795	19.38	19.57	19.79	24.35	26
11ac VHT20	5745	19.77	19.44	19.36	24.30	26
	5785	19.53	19.63	19.83	24.44	26
	5825	19.50	19.30	19.99	24.38	26
11ac VHT40	5755	19.57	19.62	19.32	24.28	26
	5795	19.36	19.68	20.05	24.48	26
11ac VHT80	5775	20.58	20.69	20.66	25.41	26
Conclusion : PASS						

Note: Power Limit = 30dBm-(10dBm-6dBm)
= 26dBm

<p>ANT 1</p> <p>11n HT40</p> <p>5755MHz</p>		<p>5795MHz</p>	
<p>5795MHz</p>		<p>11ac VHT80</p> <p>5775MHz</p>	
<p>11ac VHT40</p> <p>5755MHz</p>			

<p>ANT 2</p> <p>11n HT40</p>	
<p>5755MHz</p>	<p>5795MHz</p>
<p>5795MHz</p>	<p>11ac VHT80</p> <p>5775MHz</p>
<p>11ac VHT40</p> <p>5755MHz</p>	

<p>ANT 3</p> <p>11n HT40</p>	
<p>5755MHz</p>	<p>5795MHz</p>
<p>5795MHz</p>	<p>11ac VHT80</p> <p>5775MHz</p>
<p>11acVHT40</p> <p>5755MHz</p>	

8. SPECTRAL DENSITY TEST

8.1. Test Equipment

Item	Equipment	Manufacturer	Model No.	Serial No.	Last Cal.	Cal. Interval
1.	Spectrum	Agilent	N9030A	MY51380221	Oct.18,15	1 Year
2.	Attenuator (20dB)	Agilent	8491B	MY39262165	Apr.28,15	1 Year
3.	RF Cable	Marvelous Microwave Inc	SFL402105FLEX	NO.1	Oct.17,15	1 Year

8.2. Limit

Band 5150-5250 MHz:

The e.i.r.p spectral density shall not exceed 10 dBm in any 1.0 MHz band.

Band 5250-5350 MHz:

The power spectral density shall not exceed 11 dBm in any 1.0 MHz band.

Band 5470-5725 MHz:

The power spectral density shall not exceed 11 dBm in any 1.0 MHz band.

Band 5725-5850 MHz:

The power spectral density shall not exceed 30 dBm in any 500 KHz band.

8.3. Test Procedure

For the Band 5.15-5.25GHz:

The transmitter output was connected to a spectrum analyzer. Power density was measured by spectrum analyzer with 1MHz RBW and 3MHz VBW; Detector: RMS mode.

For the band 5.725-5.85 GHz:

The transmitter output was connected to a spectrum analyzer. Power density was measured by spectrum analyzer with 1MHz RBW and 3MHz VBW,RMS Detector.

So use the test method described in KDB789033 clause E

- 1) Set the RBW=100kHz and VBW =3MHz
- 2) Number of points in sweep ≥ 2 Span / RBW.(This ensures that bin-to-bin spacing is \leq RBW/2, so that narrowband signals are not lost between frequency bins.)
- 3) Sweep time = auto
- 4) Detector = RMS (i.e., power averaging), if available. Otherwise, use sample detector mode.
- 5) Use the “peak search” function of spectrum analyzer find the max value, then add $10\log(500\text{kHz}/\text{RBW})$ to the measured result.

Note: The cable loss and attenuator loss were offset into measure device as an amplitude offset.

8.4. Test Results

EUT: Altai A3w Indoor Dual-band 3X3 802.11ac WiFi AP		
M/N: WA3311NAC-W		
Test date: 2016-02-05	Pressure: 102.8±1.0kPa	Humidity:52.8±3.0%
Tested by: Leo-Li	Test site: RF site	Temperature:23.5±0.6 °C

Test Mode	Frequency (MHz)	Power density (dBm/500KHz)				Limit (dBm/500KHz)
		ANT 1	ANT 2	ANT 3	Total	
11a	5745	-5.812	-7.757	-7.028	-2.02	26
	5785	-5.263	-5.251	-5.310	-0.50	26
	5825	-5.892	-5.785	-5.673	-1.01	26
11n HT20	5745	-6.096	-7.706	-6.512	-1.95	26
	5785	-6.257	-6.463	-6.037	-1.48	26
	5825	-6.465	-6.179	-6.121	-1.48	26
11n HT40	5755	-9.403	-11.526	-9.860	-5.40	26
	5795	-10.164	-9.454	-9.146	-4.80	26
11ac VHT20	5745	-6.103	-8.243	-8.711	-2.76	26
	5785	-6.107	-6.061	-5.765	-1.20	26
	5825	-6.312	-6.169	-5.702	-1.28	26
11ac VHT40	5755	-9.818	-11.760	-12.163	-6.35	26
	5795	-9.573	-9.952	-9.337	-4.84	26
11ac VHT80	5775	-5.386	-4.937	-4.822	-0.27	26

Conclusion: PASS

Note: Power Limit = 30dBm-(10dBm-6dBm)
= 26dBm

<p>ANT 1</p>	
<p>11a</p> <p>5745MHz</p>	<p>11n HT20</p> <p>5745MHz</p>
<p>5785MHz</p>	<p>5785MHz</p>
<p>5825MHz</p>	<p>5825MHz</p>

11n HT40

5755MHz

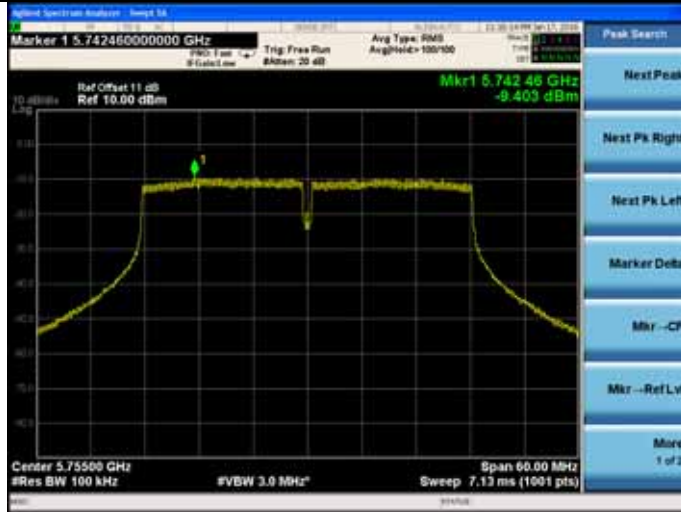

5785MHz

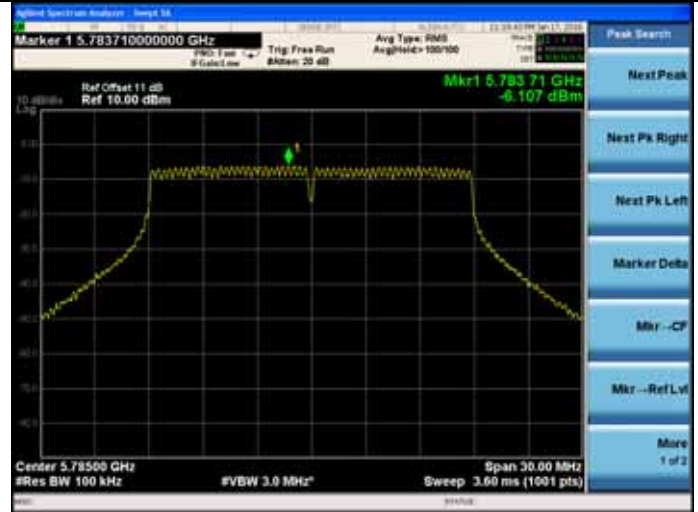

5795MHz

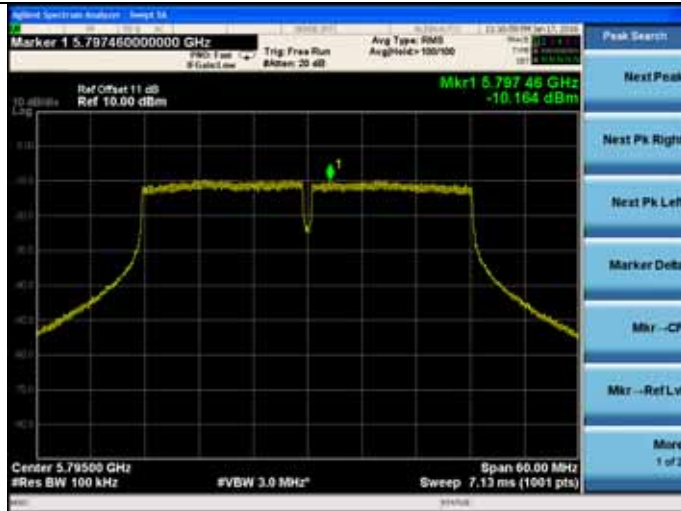

5825MHz

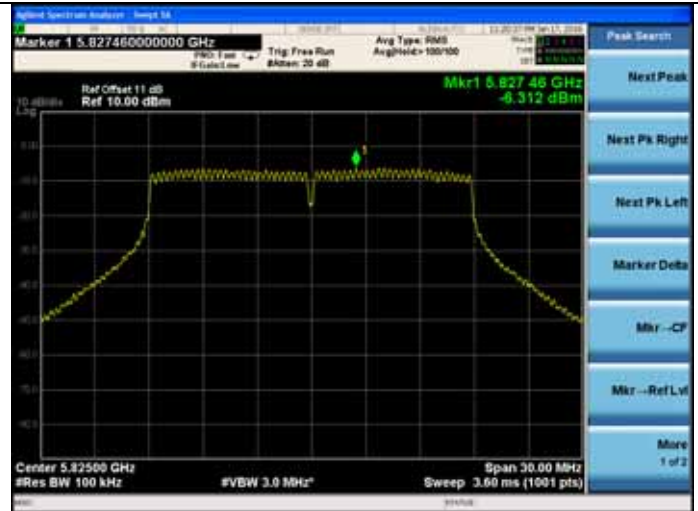

11ac VHT20

5745MHz

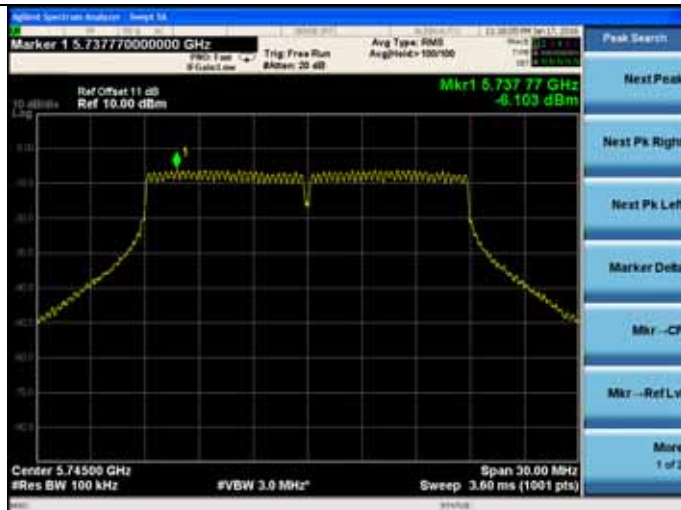

11ac VHT40

5755MHz

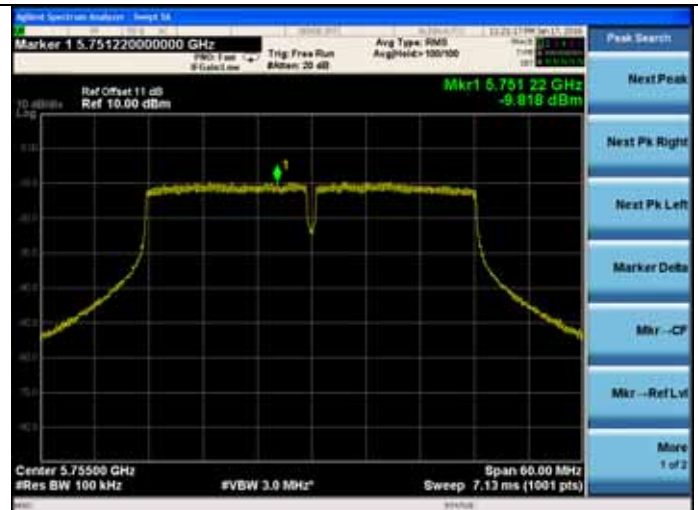

5795MHz

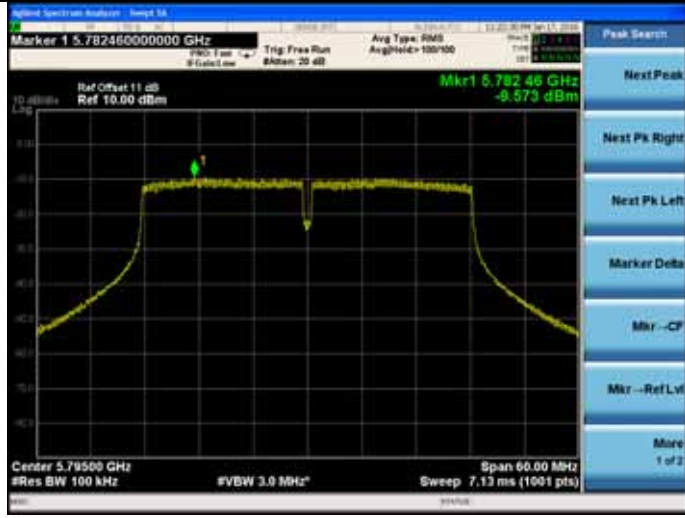

11ac VHT80

5775MHz



ANT 2	
11a	11n HT20
5745MHz	5745MHz
5785MHz	5785MHz
5825MHz	5825MHz

<p>11n HT40 5755MHz</p>	<p>5785MHz</p>
<p>5795MHz</p>	<p>5825MHz</p>
<p>11ac VHT20 5745MHz</p>	<p>11ac VHT40 5755MHz</p>

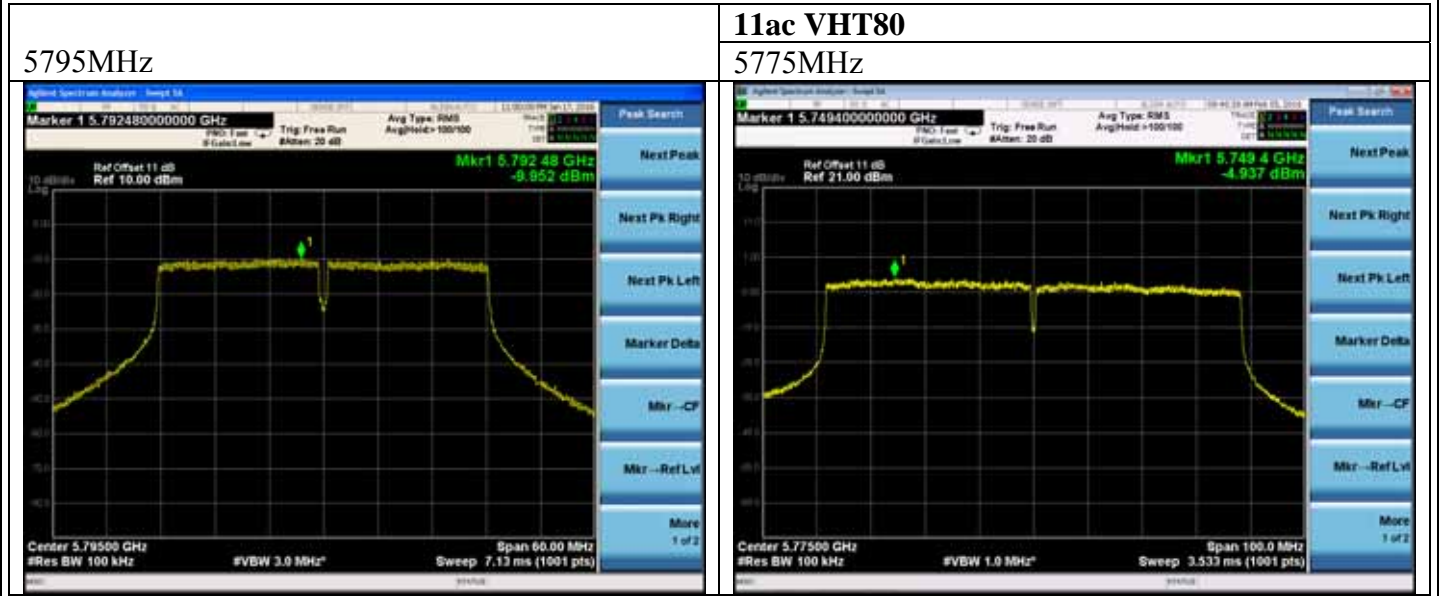

ANT 3

11a

5745MHz



11n HT20

5745MHz

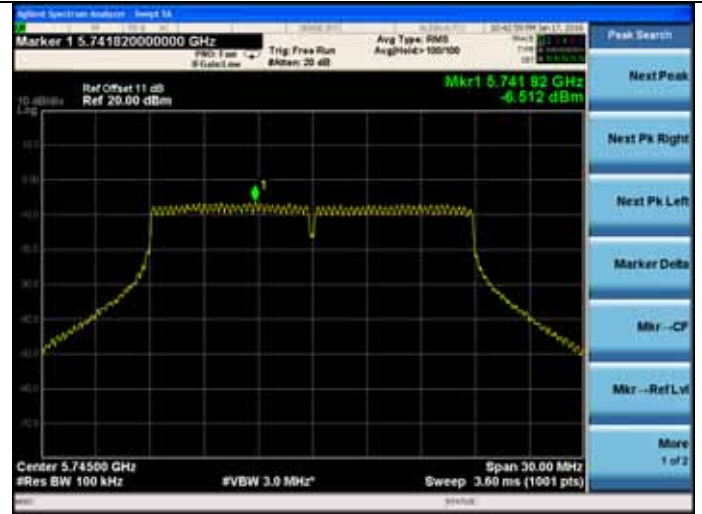

5785MHz

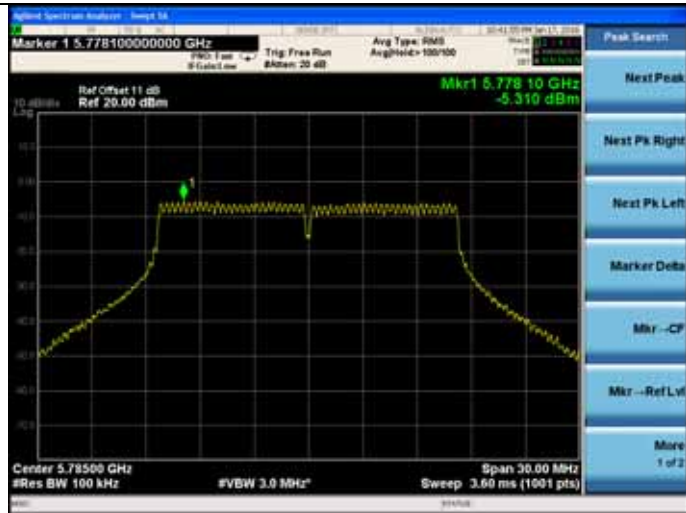

5785MHz

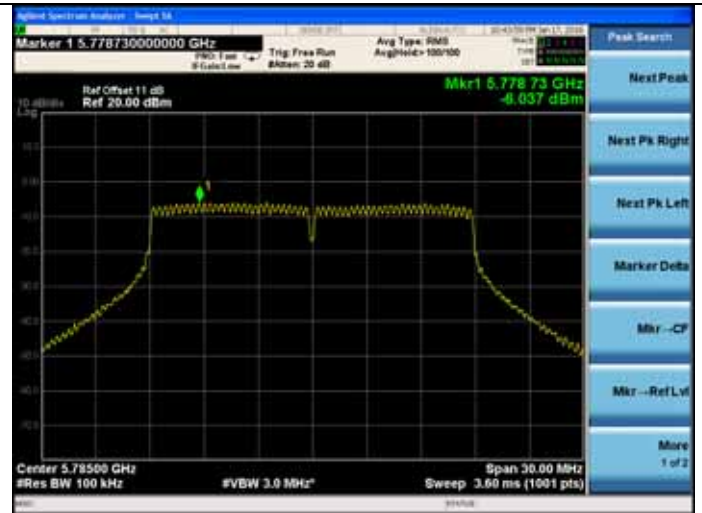

5825MHz

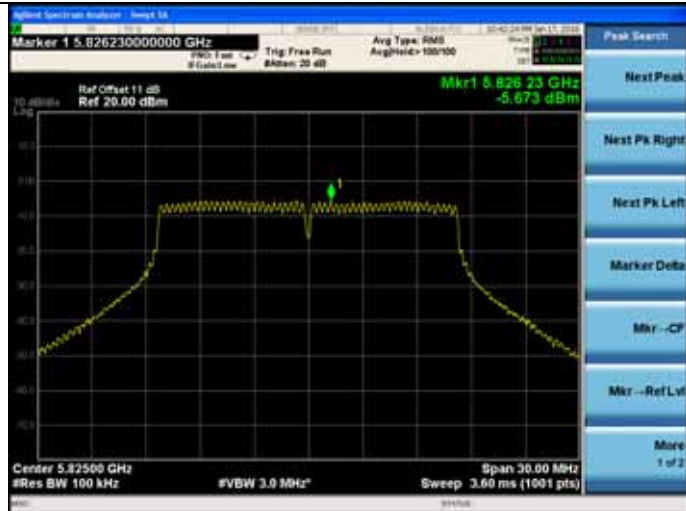

5825MHz

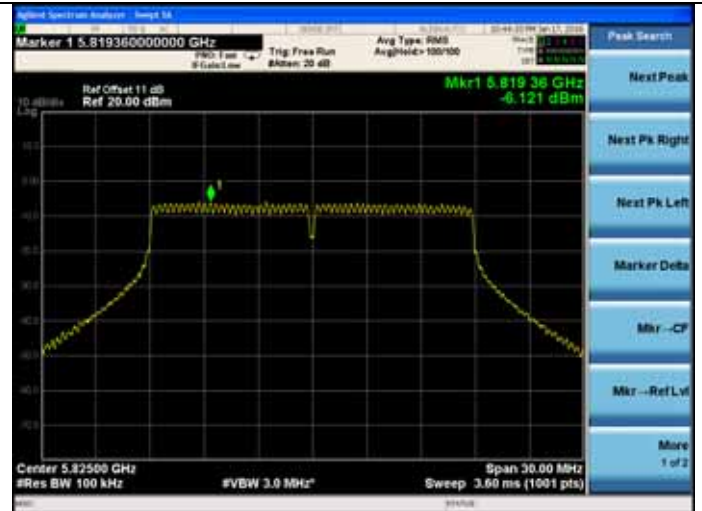

<p>11n HT40 5755MHz</p>	<p>5785MHz</p>
<p>5795MHz</p>	<p>5825MHz</p>
<p>11ac VHT20 5745MHz</p>	<p>11ac VHT40 5755MHz</p>

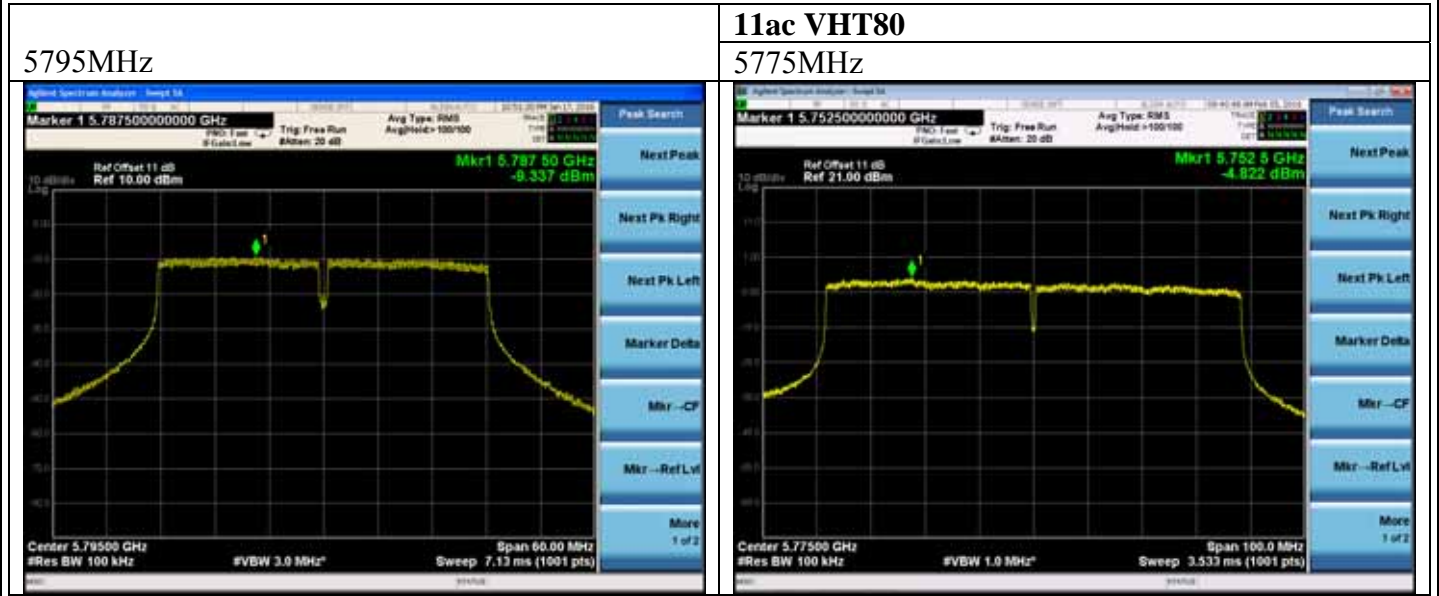

9. FREQUENCY STABILITY MEASUREMENT

9.1. Test Equipment

Item	Equipment	Manufacturer	Model No.	Serial No.	Last Cal.	Cal. Interval
1.	PXA Signal Analyzer	Agilent	N9030A	MY51380221	Oct.18,15	1 Year
2.	Amplifier	Agilent	8449B	3008A02495	Apr.28,15	1 Year
3.	Horn Antenna	ETS	3115	9510-4877	Oct.15,15	1 Year
4.	HF Cable	Hubersuhner	Sucoflex104	274094/4	Apr.28,15	1 Year

9.2. Limit

Manufacturers of U-NII devices are responsible for ensuring frequency stability such that an emissions is maintained within the band of operation under all conditions of normal operation as specified in the user's manual or ± 20 ppm

9.3. Test Procedure

1. The transmitter output (antenna port) was connected to the spectrum analyzer. EUT have transmitted absence of modulation signal and fixed channelise. Set the spectrum analyzer span to view the entire absence of modulation emissions bandwidth. Set RBW = 10 kHz, VBW = 10 kHz with peak detector and maxhold settings. f_c is declaring of channel frequency. Then the frequency error formula is $(f_c - f) / f_c \times 10^6$ ppm and the limit is less than ± 20 ppm The test extreme voltage is to change the primary supply voltage from 85 to 115 percent of the nominal value
2. Extreme temperature rule is $-30^\circ\text{C} \sim 50^\circ\text{C}$.

9.4. Test Result

EUT: Altai A3w Indoor Dual-band 3X3 802.11ac WiFi AP		
M/N: WA3311NAC-W		
Test Site: RF Site	Date: 2016-01-27	Test Engineer: Leo-Li
Temperature: 22.7±0.6 °C	Humidity: 53.5±3.0 %	Pressure: 101.2±1.0kpa

Frequency Stability vs Voltage:

Test Voltage (V)	Temp (°C)	CH	Max. Reading (MHz)	Target Frequency (MHz)	Result (ppm)	Limit (ppm)
AC 108V	25°C	CH149	5744.96	5745	-6.96	±20
		CH151	5754.96	5755	-6.95	±20
		CH155	5774.96	5775	-6.93	±20
		CH157	5784.97	5785	-5.19	±20
		CH159	5794.98	5795	-3.45	±20
		CH165	5824.97	5825	-5.15	±20

Conclusion: PASS

Test Voltage (V)	Temp (°C)	CH	Max. Reading (MHz)	Target Frequency (MHz)	Result (ppm)	Limit (ppm)
AC 120V	25°C	CH149	5744.97	5745	-5.22	±20
		CH151	5754.95	5755	-8.69	±20
		CH155	5774.94	5775	-10.39	±20
		CH157	5784.96	5785	-6.91	±20
		CH159	5794.97	5795	-5.18	±20
		CH165	5824.98	5825	-3.43	±20

Conclusion: PASS

Test Voltage (V)	Temp (°C)	CH	Max. Reading (MHz)	Target Frequency (MHz)	Result (ppm)	Limit (ppm)
AC 132V	25°C	CH149	5744.95	5745	-8.70	±20
		CH151	5754.96	5755	-6.95	±20
		CH155	5774.97	5775	-5.19	±20
		CH157	5784.95	5785	-8.64	±20
		CH159	5794.96	5795	-6.90	±20
		CH165	5824.96	5825	-6.87	±20

Conclusion: PASS

Frequency Stability vs. Temperature:

Test Voltage (V)	Temp (°C)	CH	Max. Reading (MHz)	Target Frequency (MHz)	Result (ppm)	Limit (ppm)
AC 120V	-5°C	CH149	5744.96	5745	-6.96	±20
		CH151	5754.97	5755	-5.21	±20
		CH155	5774.95	5775	-8.66	±20
		CH157	5784.96	5785	-6.91	±20
		CH159	5794.97	5795	-5.18	±20
		CH165	5824.95	5825	-8.58	±20

Conclusion: PASS

Test Voltage (V)	Temp (°C)	CH	Max. Reading (MHz)	Target Frequency (MHz)	Result (ppm)	Limit (ppm)
AC 120V	5°C	CH149	5744.95	5745	-8.70	±20
		CH151	5754.96	5755	-6.95	±20
		CH155	5774.96	5775	-6.93	±20
		CH157	5784.97	5785	-5.19	±20
		CH159	5794.95	5795	-8.63	±20
		CH165	5824.97	5825	-5.15	±20

Conclusion: PASS

Test Voltage (V)	Temp (°C)	CH	Max. Reading (MHz)	Target Frequency (MHz)	Result (ppm)	Limit (ppm)
AC 120V	15°C	CH149	5744.94	5745	-10.44	±20
		CH151	5754.95	5755	-8.69	±20
		CH155	5774.97	5775	-5.19	±20
		CH157	5784.97	5785	-5.19	±20
		CH159	5794.96	5795	-6.90	±20
		CH165	5824.96	5825	-6.87	±20

Conclusion: PASS

Test Voltage (V)	Temp (°C)	CH	Max. Reading (MHz)	Target Frequency (MHz)	Result (ppm)	Limit (ppm)
AC 120V	25°C	CH149	5744.97	5745	-5.22	±20
		CH151	5754.96	5755	-6.95	±20
		CH155	5774.97	5775	-5.19	±20
		CH157	5784.95	5785	-8.64	±20
		CH159	5794.96	5795	-6.90	±20
		CH165	5824.97	5825	-5.15	±20

Conclusion: PASS

Test Voltage (V)	Temp (°C)	CH	Max. Reading (MHz)	Target Frequency (MHz)	Result (ppm)	Limit (ppm)
AC 120V	35°C	CH149	5744.97	5745	-5.22	±20
		CH151	5754.96	5755	-6.95	±20
		CH155	5774.96	5775	-6.93	±20
		CH157	5784.97	5785	-5.19	±20
		CH159	5794.96	5795	-6.90	±20
		CH165	5824.95	5825	-8.58	±20

Conclusion: PASS

Test Voltage (V)	Temp (°C)	CH	Max. Reading (MHz)	Target Frequency (MHz)	Result (ppm)	Limit (ppm)
AC 120V	45°C	CH149	5744.97	5745	-5.22	±20
		CH151	5754.96	5755	-6.95	±20
		CH155	5774.97	5775	-5.19	±20
		CH157	5784.95	5785	-8.64	±20
		CH159	5794.98	5795	-3.45	±20
		CH165	5824.96	5825	-6.87	±20

Conclusion: PASS

Test Voltage (V)	Temp (°C)	CH	Max. Reading (MHz)	Target Frequency (MHz)	Result (ppm)	Limit (ppm)
AC 120V	55°C	CH149	5744.94	5745	-10.44	±20
		CH151	5754.95	5755	-8.69	±20
		CH155	5774.97	5775	-5.19	±20
		CH157	5784.95	5785	-8.64	±20
		CH159	5794.95	5795	-8.63	±20
		CH165	5824.98	5825	-3.43	±20

Conclusion: PASS

10. MPE ESTIMATION

10.1. Limit for General Population/ Uncontrolled Exposures

Frequency	Power density (mW/ cm ²)	Averaging time(minutes)
300MHz----1.5GHz	F/1500	30
1.5GHz---100GHz	1.0	30

Note: F= Frequency in MHz

10.2. Estimation Result

EUT: Altai A3w Indoor Dual-band 3X3 802.11ac WiFi AP		
M/N: WA3311NAC-W		
Test date: 2016-01-25	Pressure: 101.2±1.0 kpa	Humidity: 54.3±3.0%
Tested by: Leo-Li	Test site: RF site	Temperature:22.9±0.6 °C

Test Mode	Frequency (MHz)	Peak Output Power (dBm)	Output Power (mW)	Antenna Gain (dBi)	Antenna Gain (Linear)	MPE
11a	5745	24.86	306.20	10	10.00	0.6095
	5785	24.68	293.76	10	10.00	0.5847
	5825	24.55	285.10	10	10.00	0.5675
11n HT20	5745	24.42	276.69	10	10.00	0.5507
	5785	24.62	289.73	10	10.00	0.5767
	5825	24.32	270.40	10	10.00	0.5382
11n HT40	5755	24.33	271.02	10	10.00	0.5394
	5795	24.35	272.27	10	10.00	0.5419
11ac VHT20	5745	24.30	269.15	10	10.00	0.5357
	5785	24.44	277.97	10	10.00	0.5533
	5825	24.38	274.16	10	10.00	0.5457
11ac VHT40	5755	24.28	267.92	10	10.00	0.5333
	5795	24.48	280.54	10	10.00	0.5584
11ac VHT80	5775	25.41	347.54	10	10.00	0.6918

$$MPE = \frac{PG}{4\pi R^2} \quad (R=20 \text{ cm})$$

11. ANTENNA REQUIREMENT

11.1. Standard Applicable

For intentional device, according to FCC 47 CFR Section 15.203, an intentional radiator shall be designed to ensure that no antenna other than that furnished by the responsible party shall be used with the device. And according to FCC 47 CFR Section 15.407 (a), if transmitting antennas of directional gain greater than 6dBi are used, the power shall be reduced by the amount in dB that the directional gain of the antenna exceeds 6dBi.

11.2. Antenna Connected Construction

The antennas used for this product are Built-in antenna that no antenna other than that furnished by the responsible party shall be used with the device, the maximum peak gain of the transmit antenna is 10dBi.

12. DEVIATION TO TEST SPECIFICATIONS

[NONE]