

Altai Technologies Ltd.

WA2011N-E

802.11 a/b/g/n 2.4/5GHz

WA2011N-E					Title	
Date		Size A2	Rev 06	Sheet	1	of 18
					DWG NO	

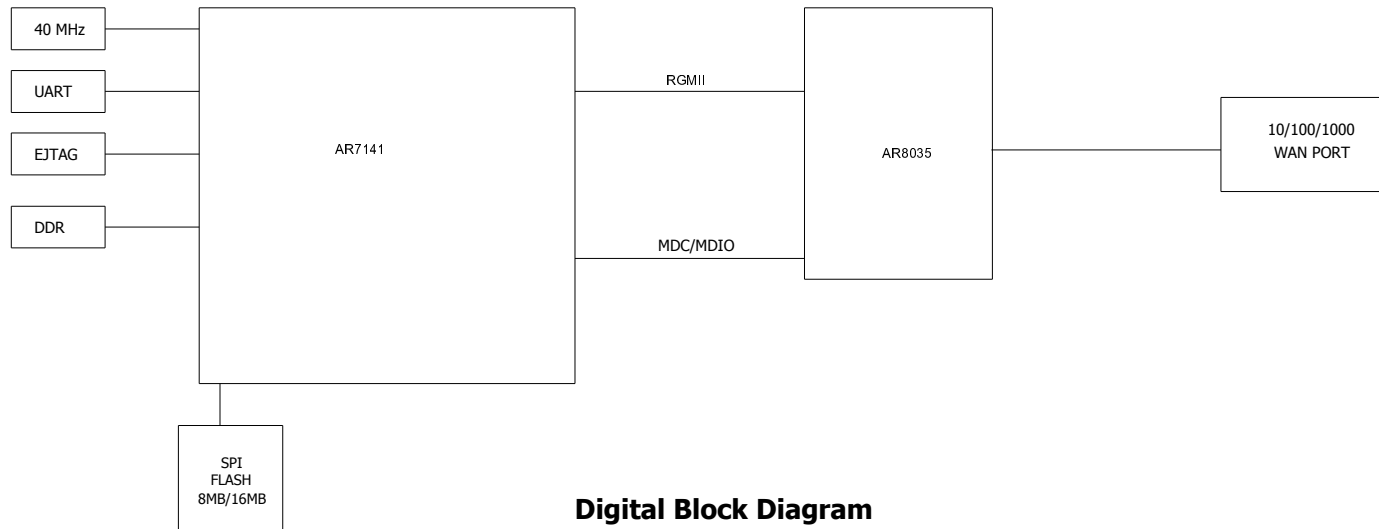

Digital Block Diagram

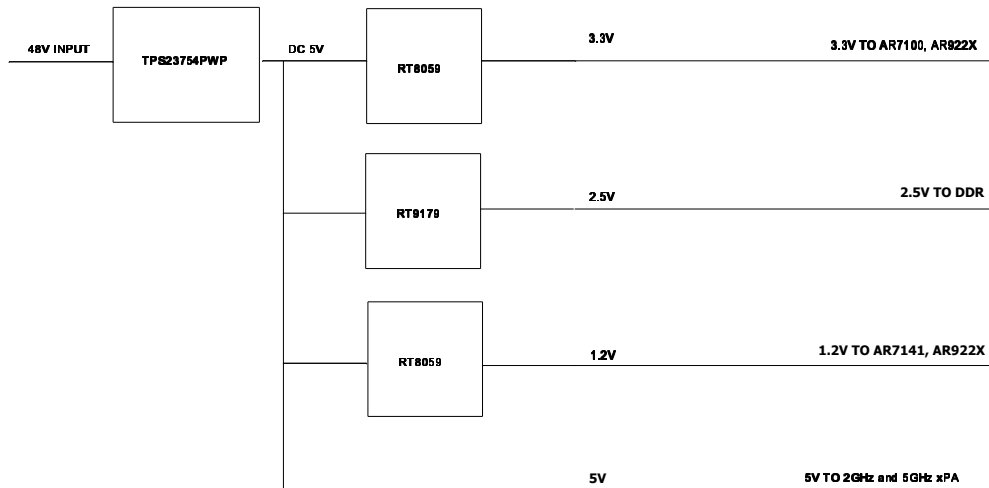

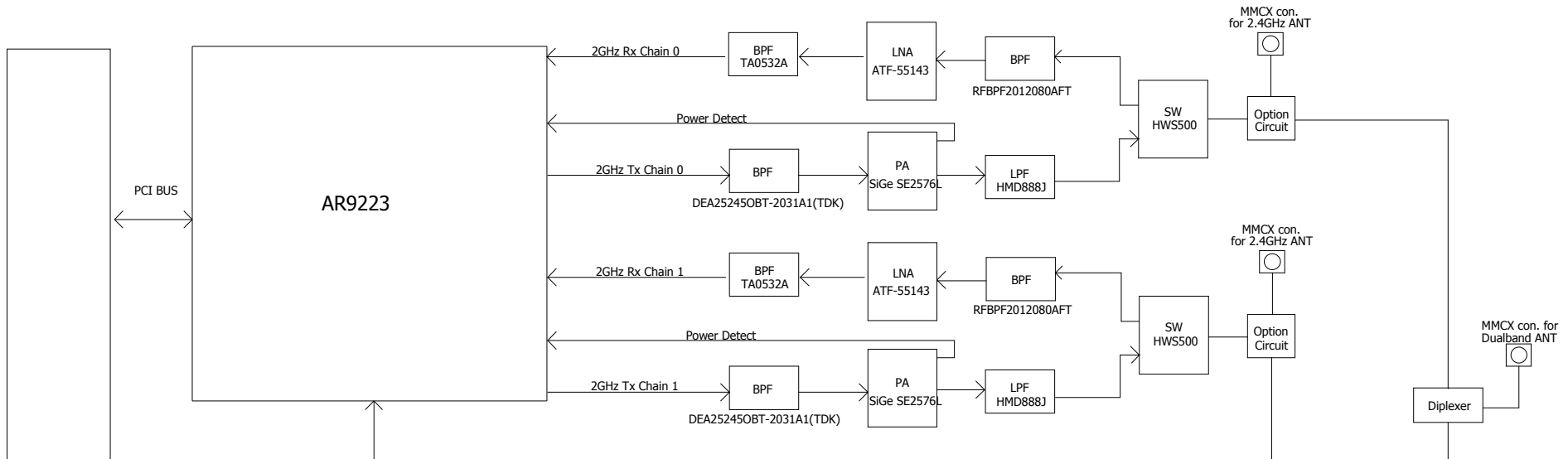

2.4GHz Radio Block Diagram

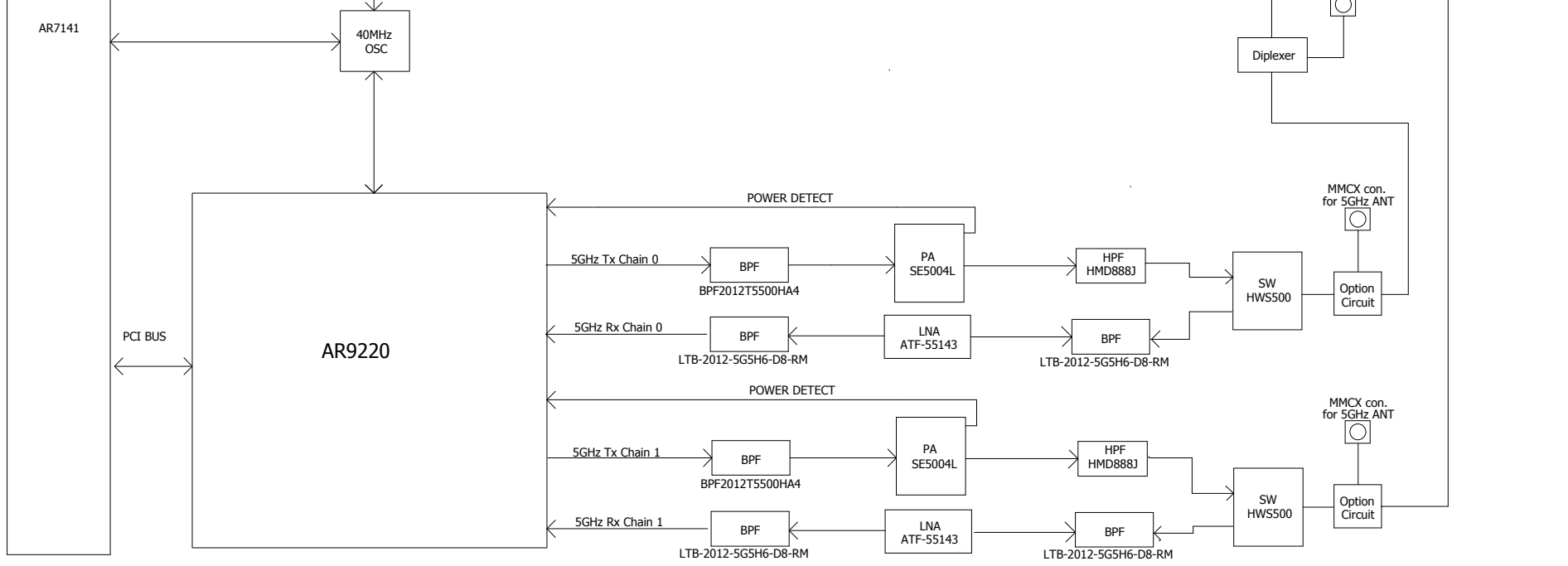

5GHz Radio Block Diagram

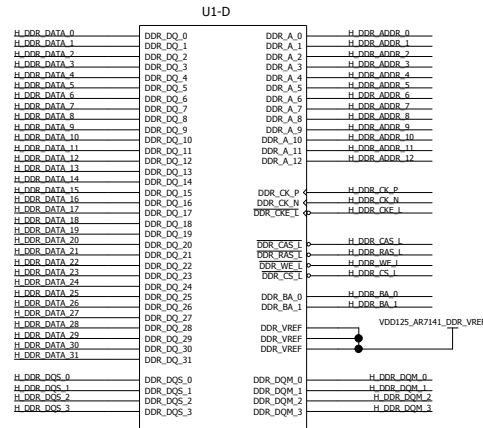
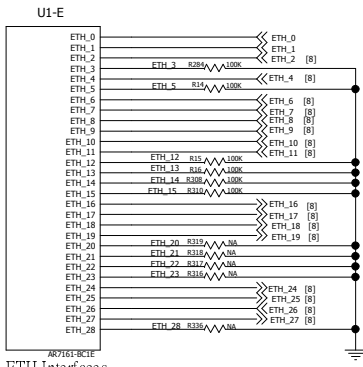
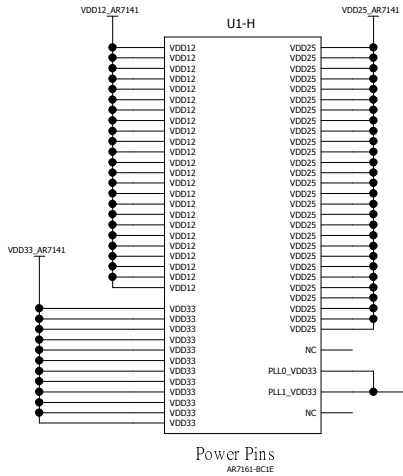
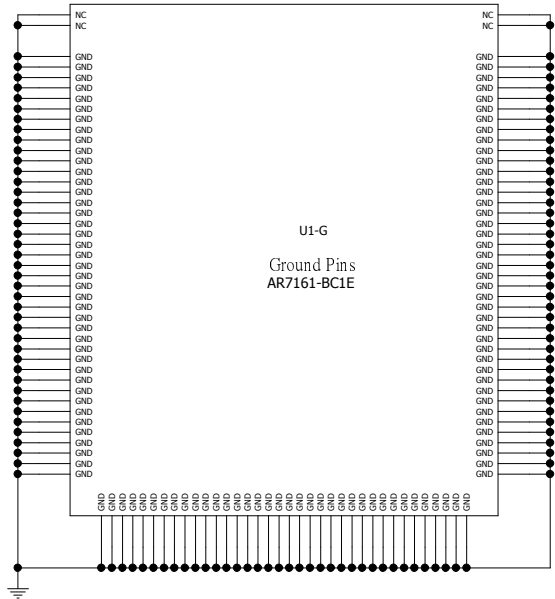

ETH Interfaces

MII interfaces

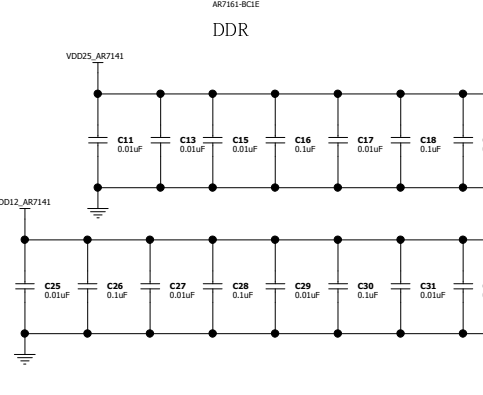
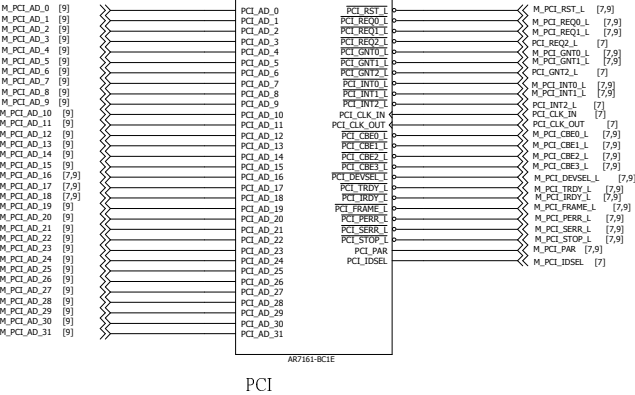

DDR

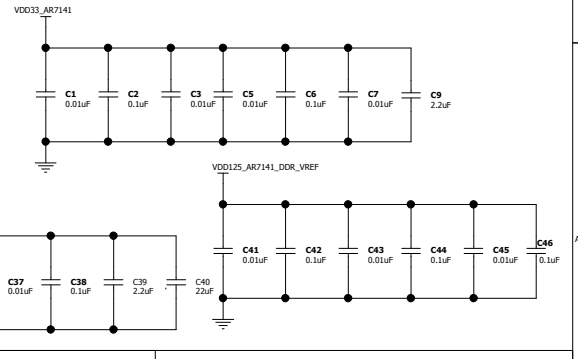
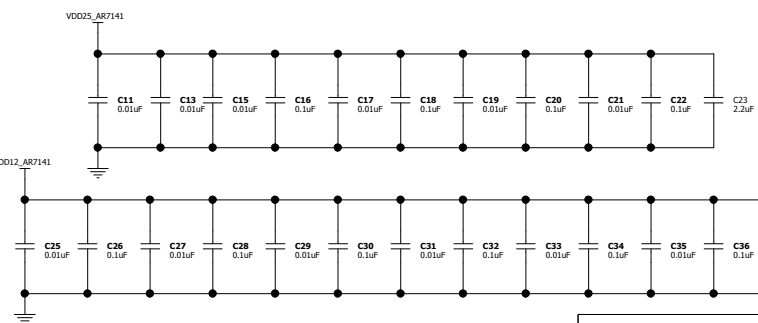

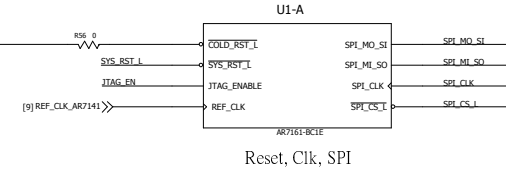
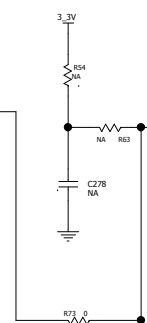
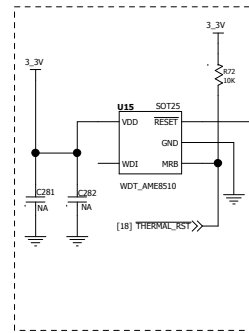
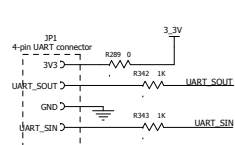
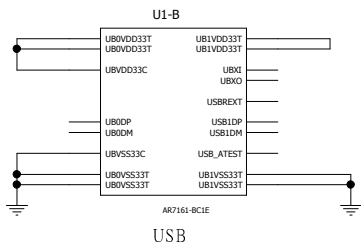

Reset, Clk, SPI

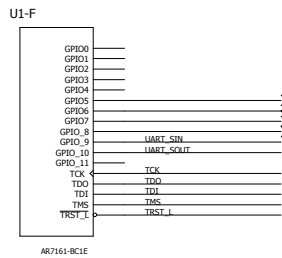
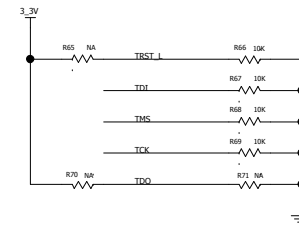
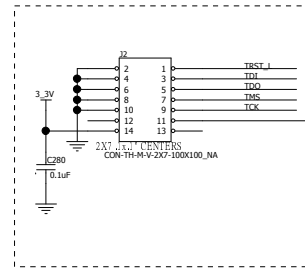
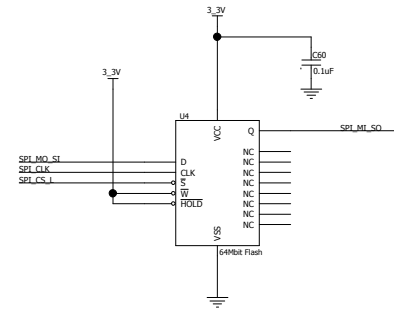
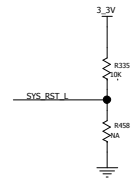

GPIO

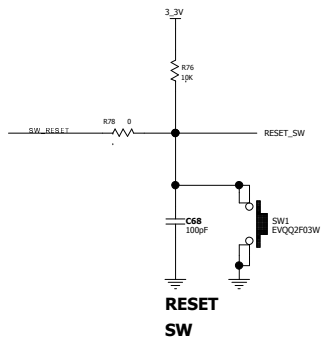
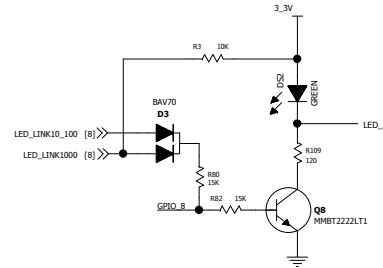
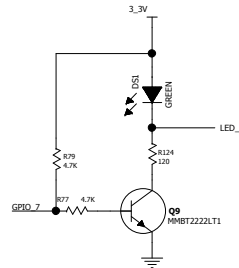

RESET SW

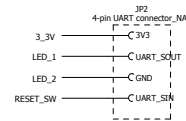

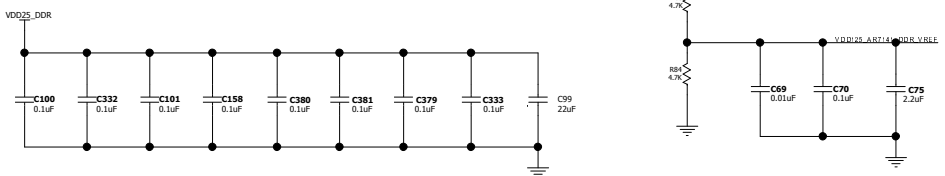
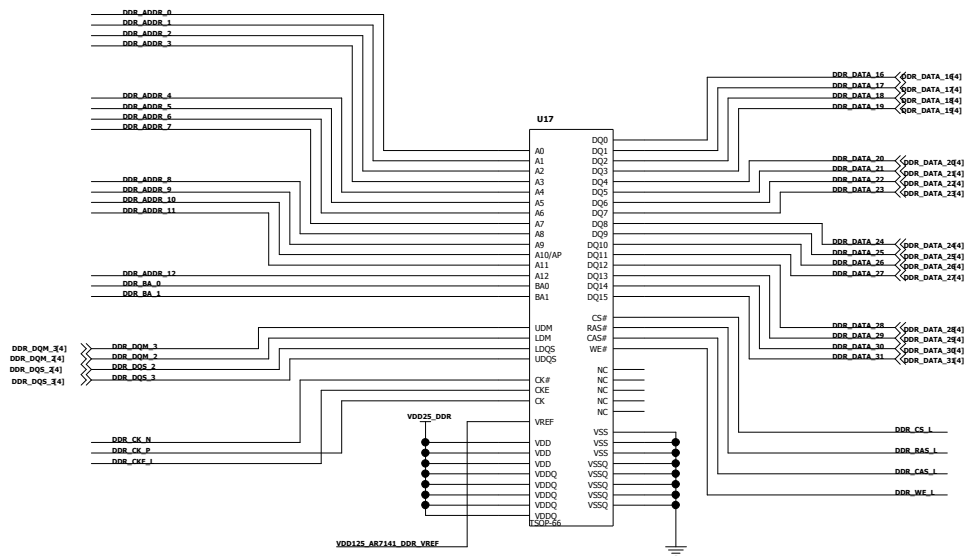
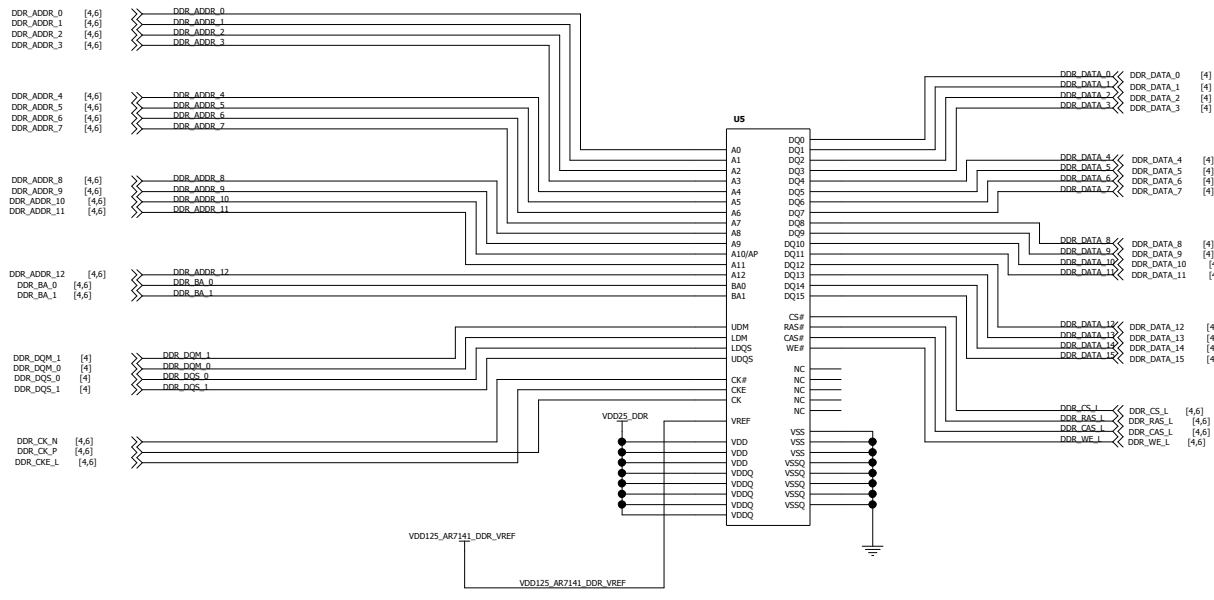

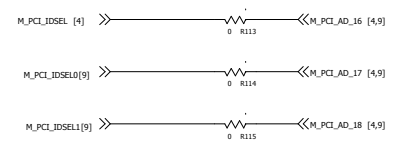
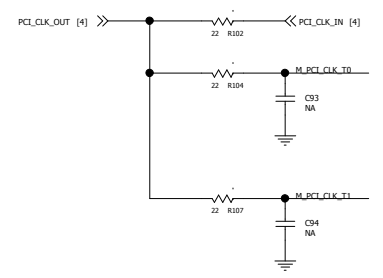
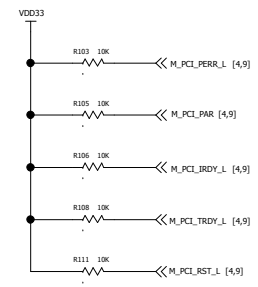
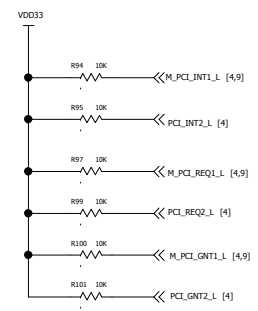
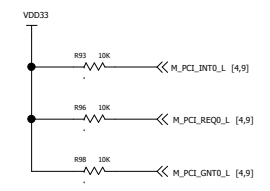
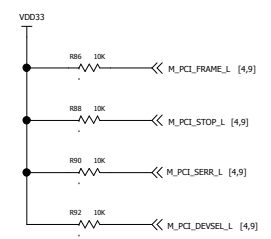
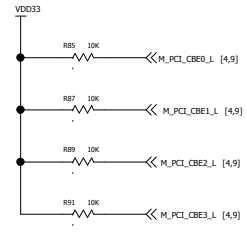

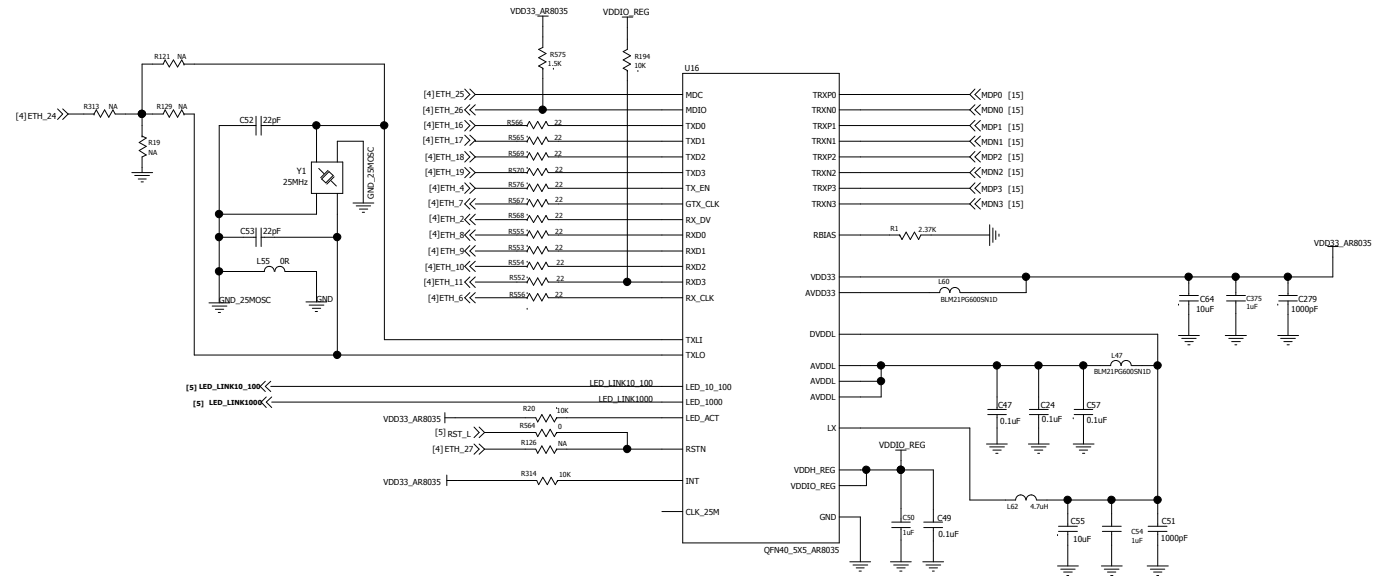

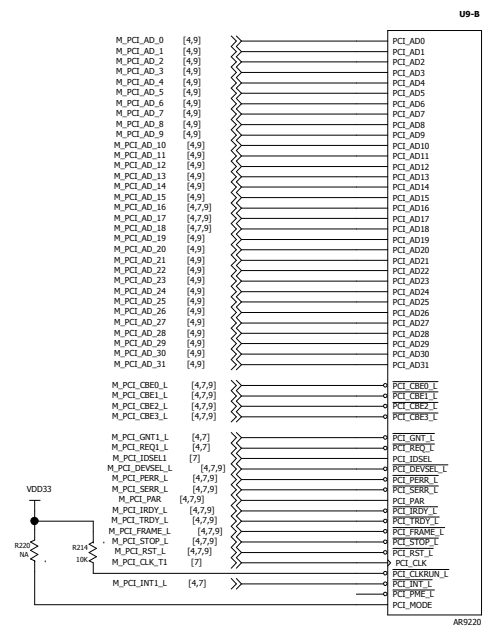
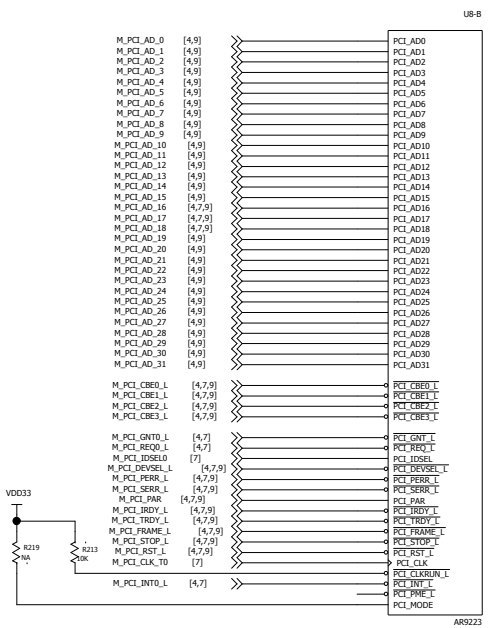
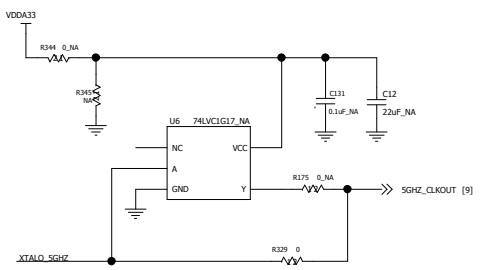
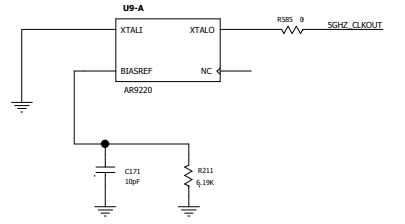
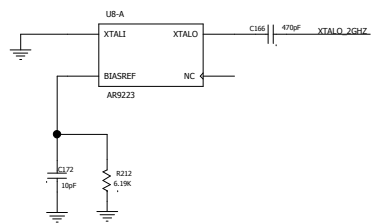
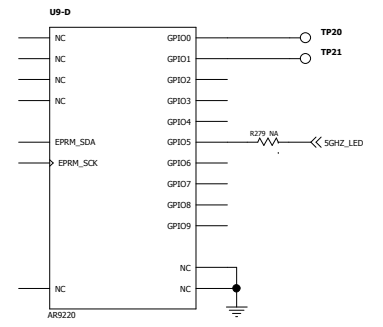
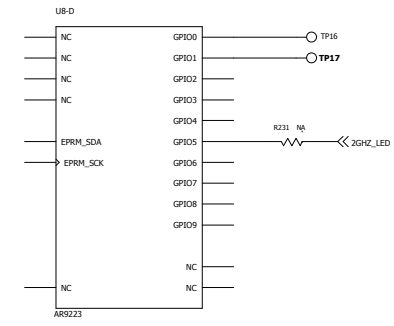
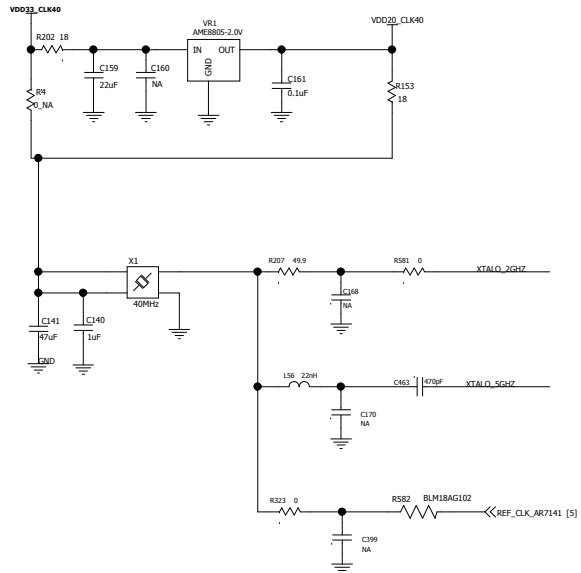

<Core Design>

WA2011N-E				Title AR9223 AR9220 Digital	
Date	Size A2	Rev 06	Sheet 9	of 18	PWG NO

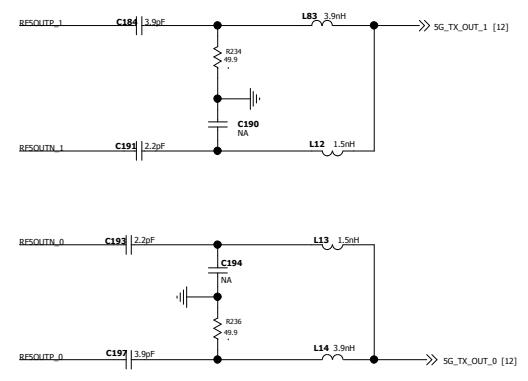
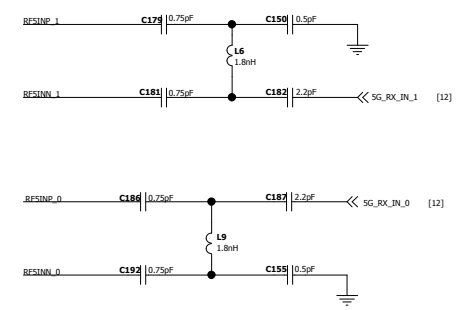
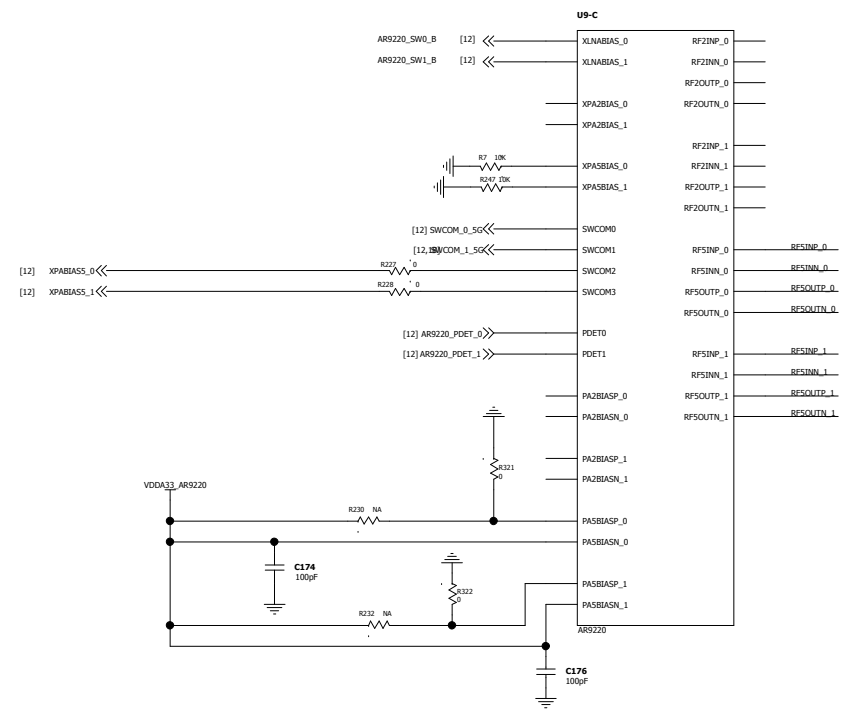
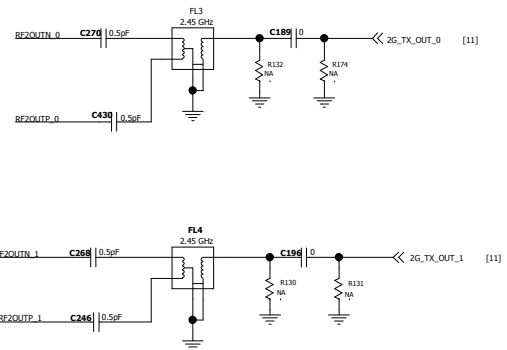
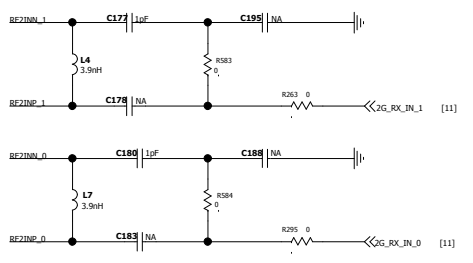
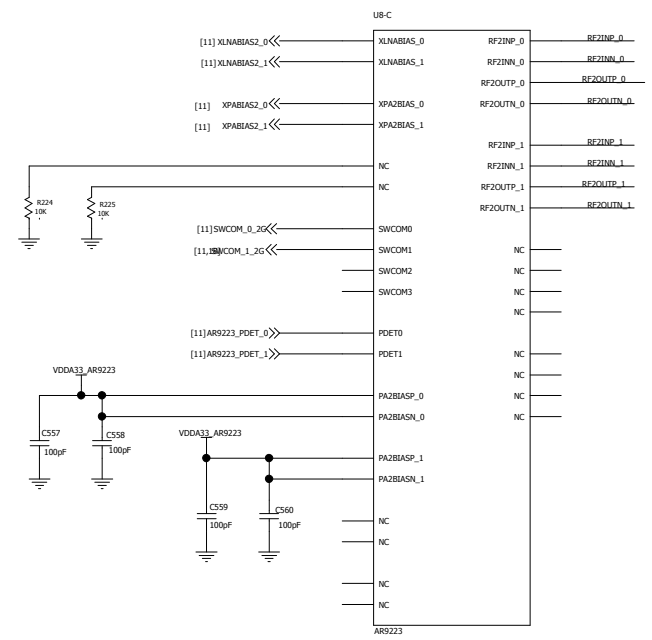

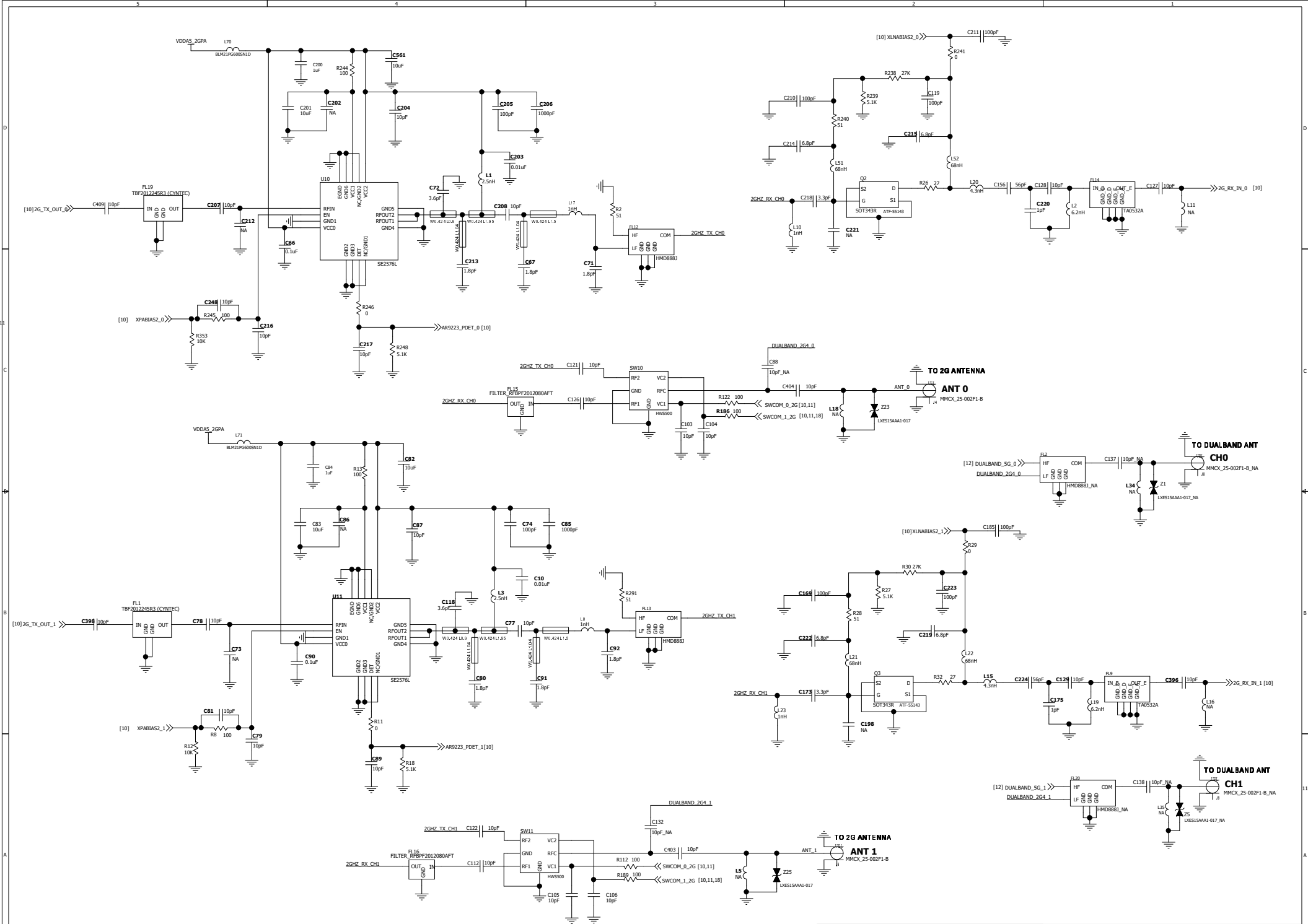

WA2011N-E				Title 2GHz TX Path	
Date	Size A2	Rev 06	Sheet 11 of 18	DWG NO	

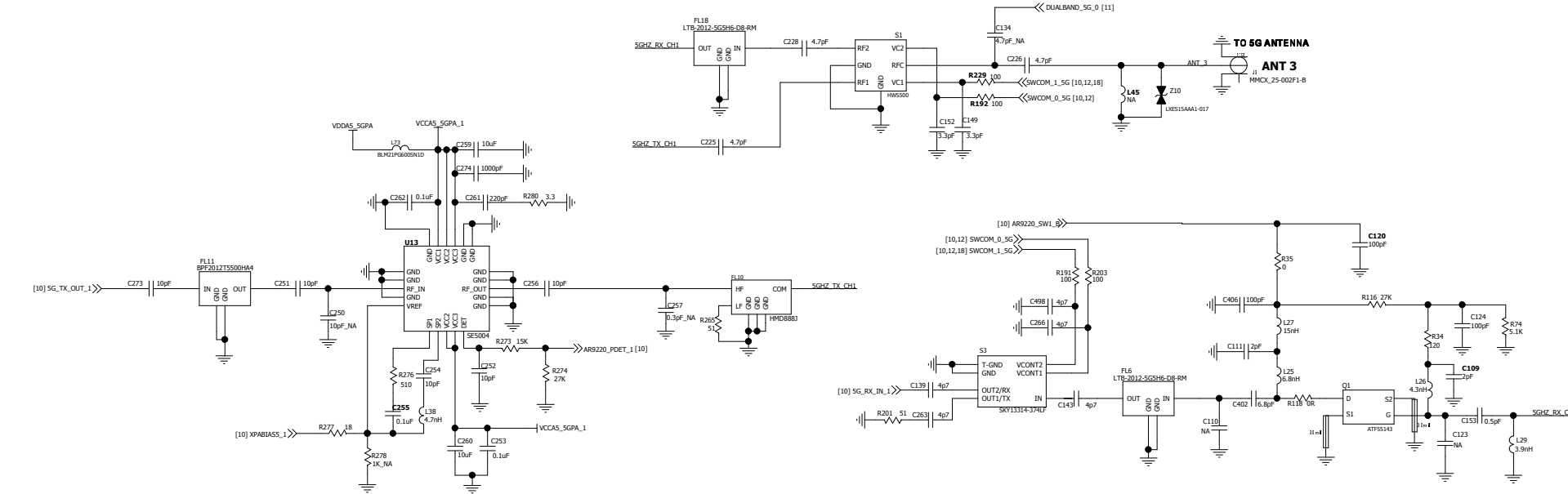
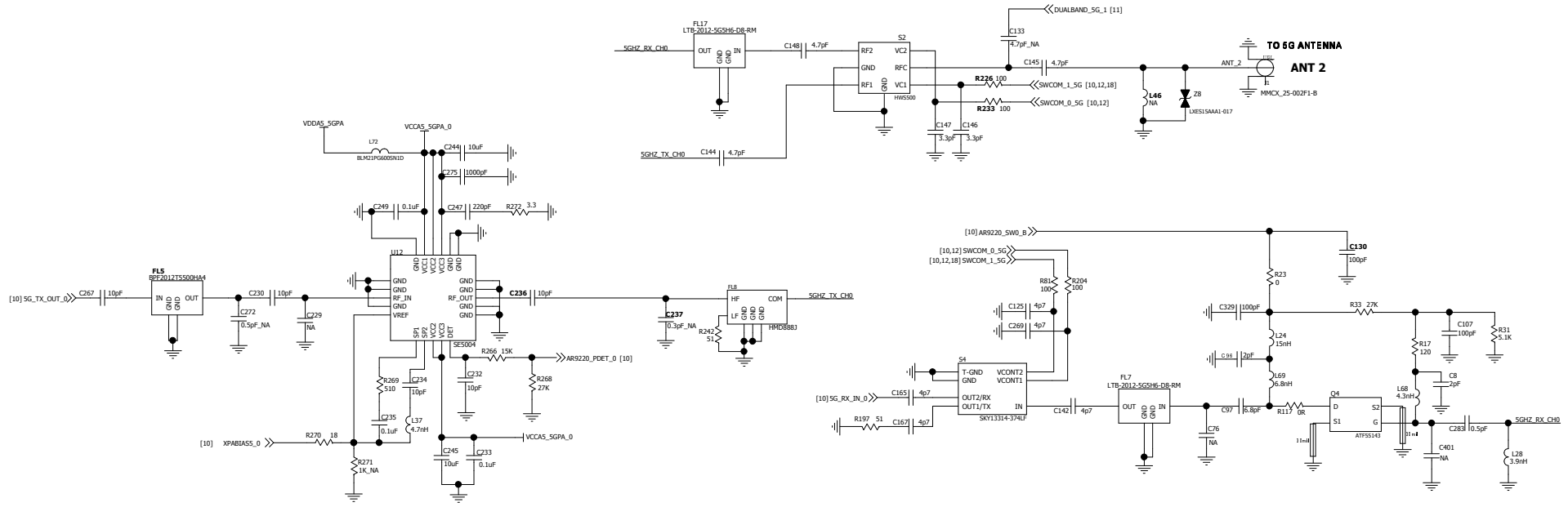

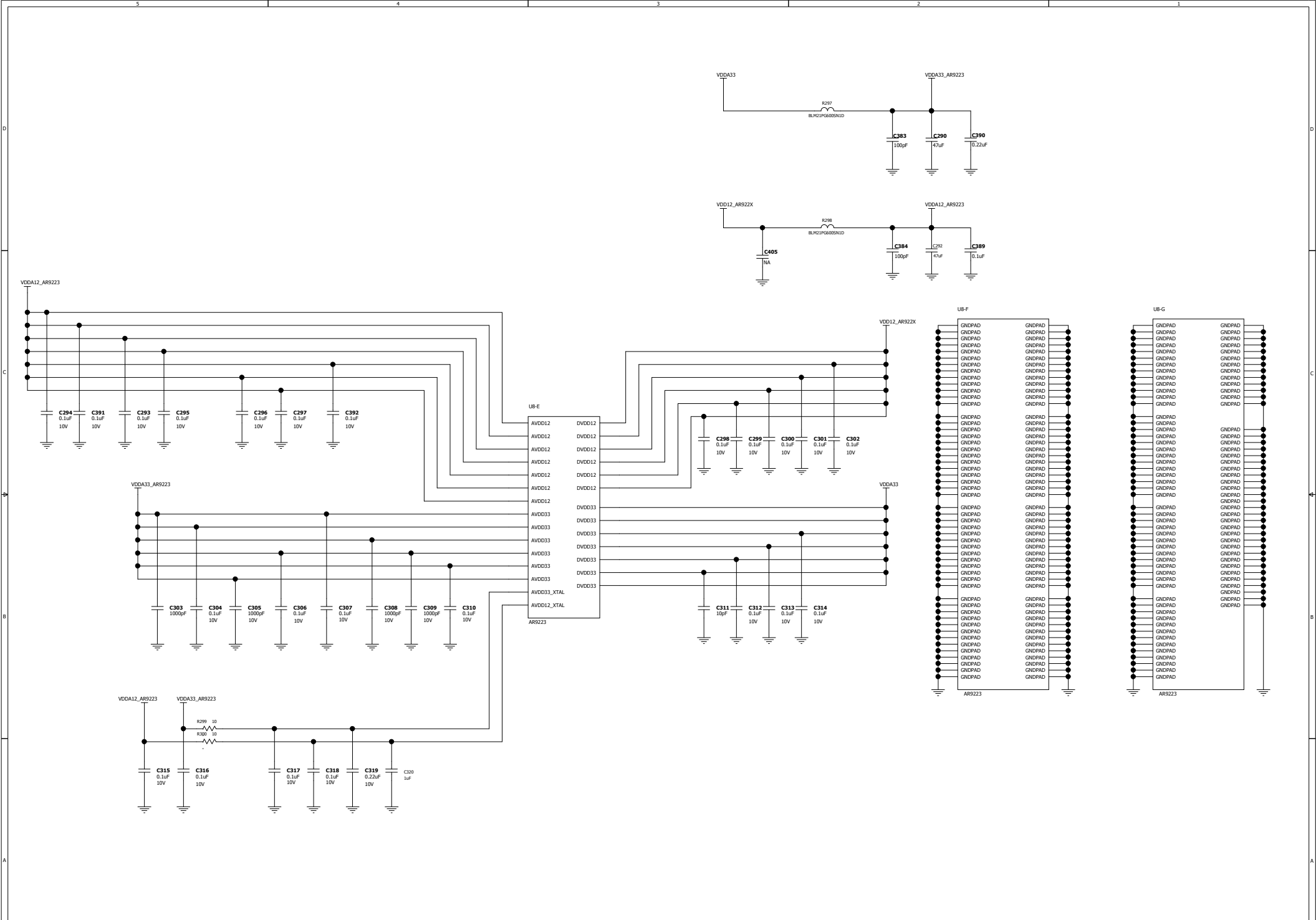

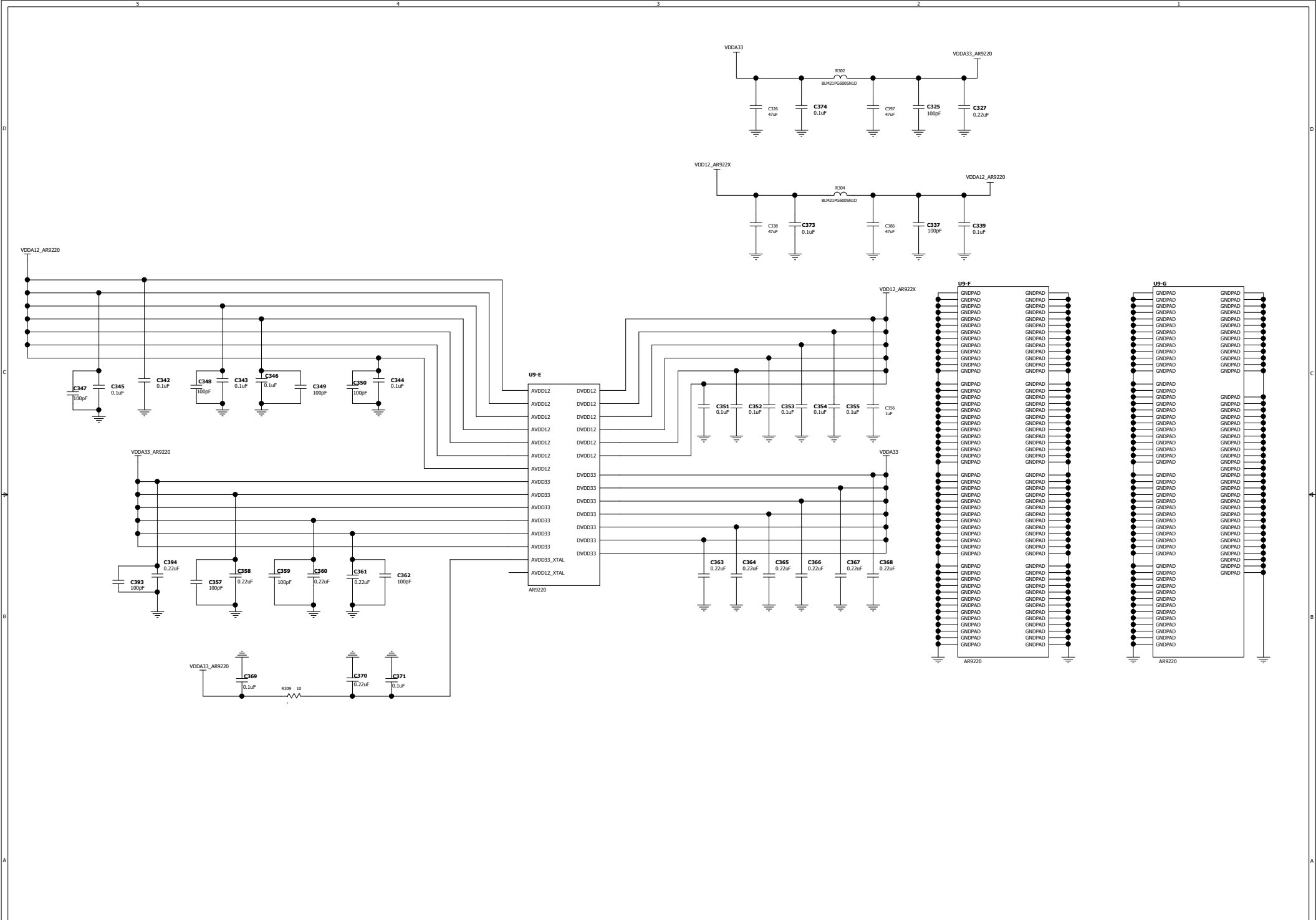

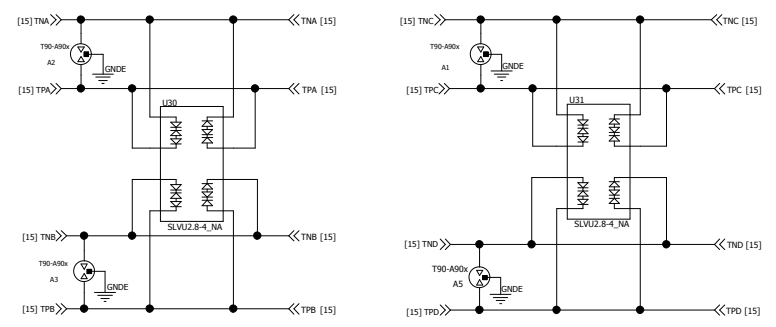
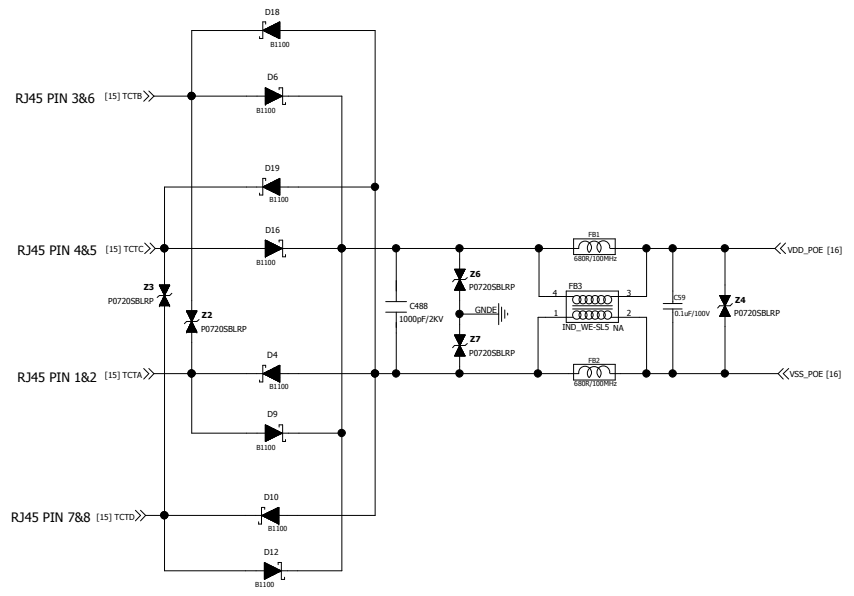
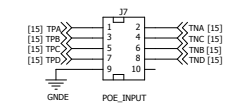
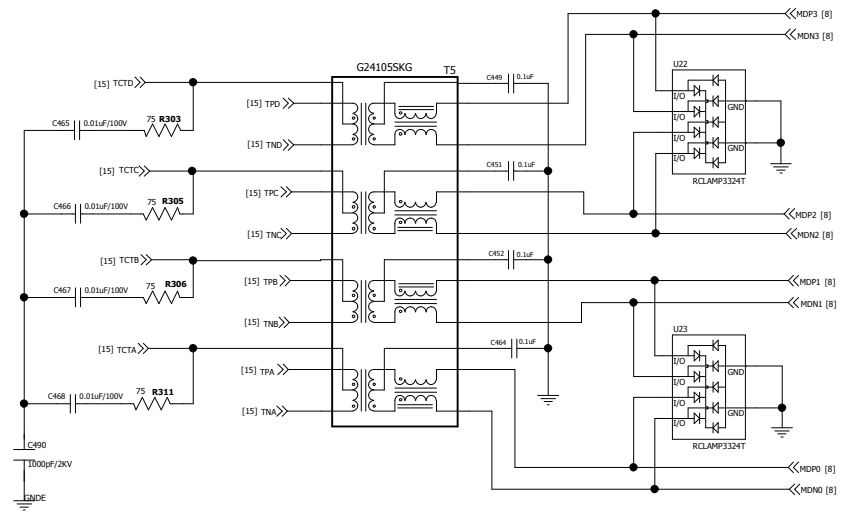

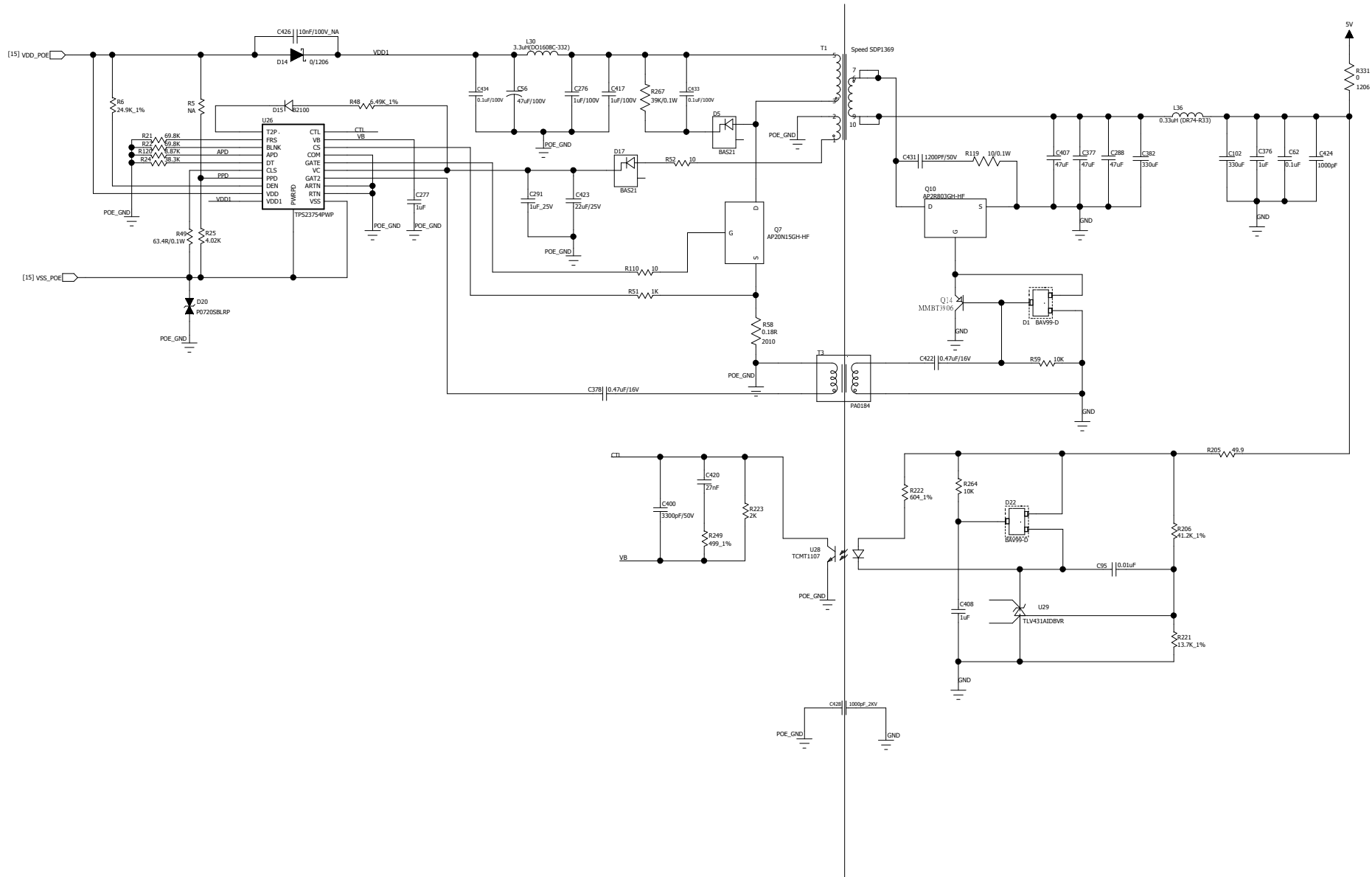

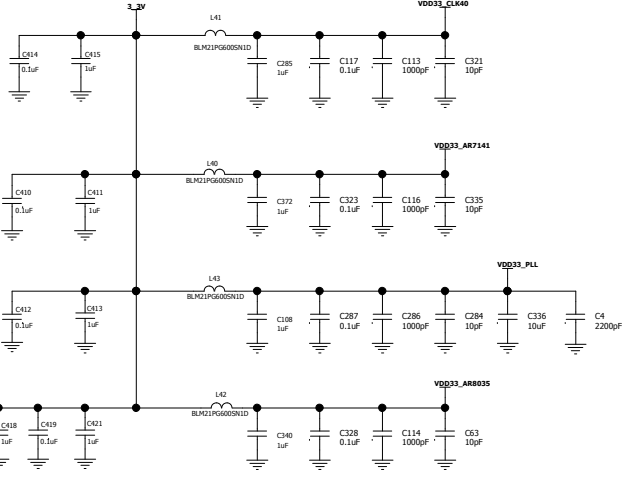
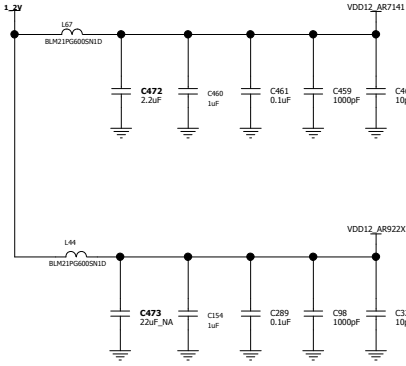
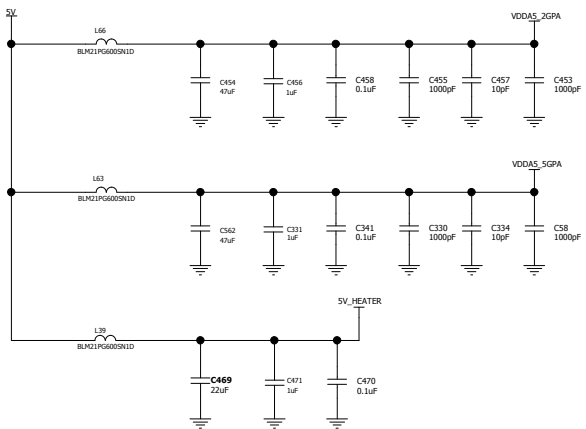
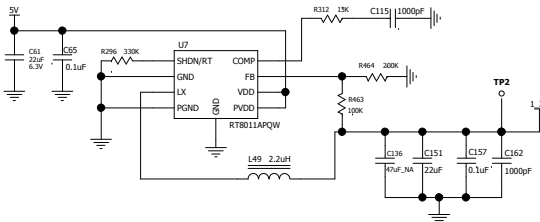
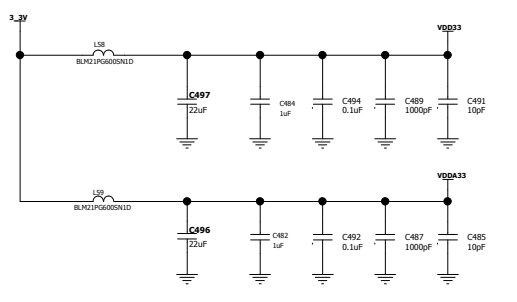
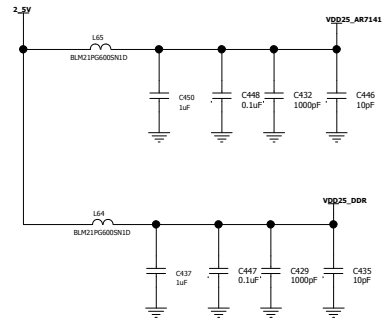
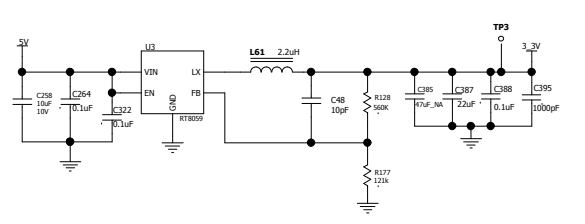
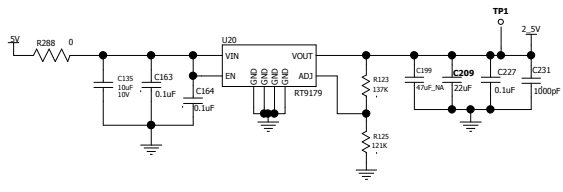
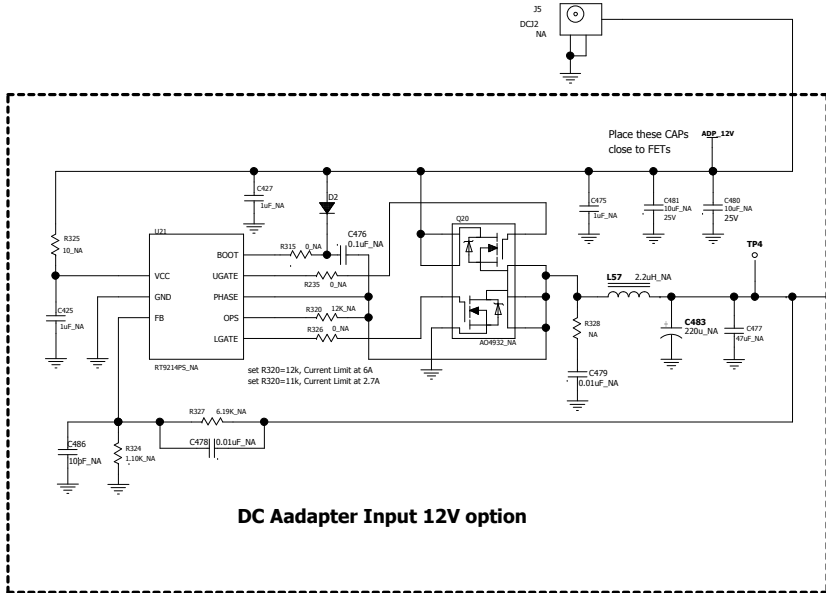

WA2011N-E					Title	DC_DC	
Date	Size A2	Rev 06	Sheet	17 of 18		PWG NO	

