



FCC PART 15, SUBPART C  
IC RSS-247, ISSUE 1, MAY 2015

TEST AND MEASUREMENT REPORT

For

**Marvell Semiconductor, Inc.**

5488 Marvell Lane,  
Santa Clara, CA 95054, USA

**FCC ID: UAYK501**  
**IC: 6549A-K501**

<b>Report Type:</b> Original Report	<b>Product Type:</b> Software Development Kit with Wi-Fi Connectivity
<b>Prepared By:</b> Leonard Gray Associate Engineer	<i>Leonard Gray</i>
<b>Report Number:</b> R1512144-247	
<b>Report Date:</b> 2016-01-27	
<b>Reviewed By:</b> Bo Li RF Supervisor	<i>Bo Li</i>
Bay Area Compliance Laboratories Corp. 1274 Anvilwood Avenue, Sunnyvale, CA 94089, USA Tel: (408) 732-9162 Fax: (408) 732-9164	

**Note:** This test report is prepared for the customer shown above and for the device described herein. It may not be duplicated or used in part without prior written consent from Bay Area Compliance Laboratories Corp. This report **must not** be used by the customer to claim product certification, approval, or endorsement by A2LA\*, NIST, or any agency of the Federal Government.

\* This report may contain data that are not covered by the A2LA accreditation and are marked with an asterisk “\*”

## TABLE OF CONTENTS

<b>1</b>	<b>General Description.....</b>	<b>5</b>
1.1	Product Description for Equipment Under Test (EUT) .....	5
1.2	Mechanical Description of EUT .....	5
1.3	Objective.....	5
1.4	Related Submittal(s)/Grant(s) .....	5
1.5	Test Methodology .....	5
1.6	Measurement Uncertainty .....	5
1.7	Test Facility .....	6
<b>2</b>	<b>System Test Configuration.....</b>	<b>7</b>
2.1	Justification .....	7
2.2	EUT Exercise Software.....	7
2.3	Equipment Modifications.....	9
2.4	Local Support Equipment .....	9
2.5	EUT Internal Configuration Details.....	9
2.6	Power Supply and Line Filter .....	9
2.7	Interface Ports and Cabling.....	9
<b>3</b>	<b>Summary of Test Results .....</b>	<b>10</b>
<b>4</b>	<b>FCC §15.247(i) &amp; IC RSS §102 – RF Exposure.....</b>	<b>11</b>
4.1	Applicable Standards .....	11
4.2	MPE Prediction.....	12
4.3	MPE Results for FCC .....	12
4.4	RF exposure evaluation exemption for IC .....	12
<b>5</b>	<b>FCC §15.203 &amp; IC RSS-Gen §8.3 - Antenna Requirements.....</b>	<b>13</b>
5.1	Applicable Standards .....	13
5.2	Antenna List and Details.....	13
<b>6</b>	<b>FCC §15.207 &amp; IC RSS-Gen §8.8 – AC Line Conducted Emissions.....</b>	<b>14</b>
6.1	Applicable Standards .....	14
6.2	Test Setup .....	14
6.3	Test Procedure .....	14
6.4	Test Setup Block Diagram .....	15
6.5	Corrected Amplitude & Margin Calculation.....	15
6.6	Test Equipment List and Details.....	16
6.7	Test Environmental Conditions .....	16
6.8	Summary of Test Results.....	16
6.9	Conducted Emissions Test Plots and Data.....	17
<b>7</b>	<b>FCC §15.209, §15.247(d) &amp; IC RSS-247 §5.5, RSS-Gen §8.9, §8.10 - Spurious Radiated Emissions.....</b>	<b>19</b>
7.1	Applicable Standards .....	19
7.2	Test Setup .....	22
7.3	Test Procedure .....	22
7.4	Corrected Amplitude & Margin Calculation.....	22
7.5	Test Equipment List and Details.....	23
7.6	Test Environmental Conditions .....	23
7.7	Summary of Test Results.....	23
7.8	Radiated Emissions Test Data and Plots.....	24
<b>8</b>	<b>FCC §15.247(a)(2) &amp; IC RSS-247 §5.2 - 6 dB &amp; 99% Emission Bandwidth.....</b>	<b>31</b>
8.1	Applicable Standards .....	31
8.2	Measurement Procedure.....	31
8.3	Test Equipment List and Details.....	31
8.4	Test Environmental Conditions .....	31
8.5	Test Results.....	32

<b>9</b>	<b>FCC §15.247(b) &amp; IC RSS-247 §5.4 - Output Power Measurement .....</b>	<b>38</b>
9.1	Applicable Standards .....	38
9.2	Measurement Procedure.....	38
9.3	Test Equipment List and Details.....	38
9.4	Test Environmental Conditions .....	39
9.5	Test Results.....	39
<b>10</b>	<b>FCC §15.247(d) &amp; IC RSS-247 §5.5 - Spurious Emissions at Antenna Port and Band Edges.....</b>	<b>45</b>
10.1	Applicable Standards .....	45
10.2	Measurement Procedure.....	45
10.3	Test Equipment List and Details.....	45
10.4	Test Environmental Conditions .....	46
10.5	Test Results.....	46
<b>11</b>	<b>FCC §15.247(e) &amp; IC RSS-247 §5.2 - Power Spectral Density .....</b>	<b>59</b>
11.1	Applicable Standards .....	59
11.2	Measurement Procedure.....	59
11.3	Test Equipment List and Details.....	59
11.4	Test Environmental Conditions .....	59
11.5	Test Results.....	60
<b>12</b>	<b>Exhibit A – FCC &amp; IC Equipment Labeling Requirements .....</b>	<b>66</b>
12.1	FCC ID Label Requirements .....	66
12.2	IC Label Requirements .....	67
12.3	FCC & IC Label Contents and Location.....	68
<b>13</b>	<b>Exhibit B - Test Setup Photographs.....</b>	<b>69</b>
13.1	Radiated Emission below 1 GHz Front View .....	69
13.2	Radiated Emission below 1 GHz Rear View .....	69
13.3	Radiated Emission above 1 GHz Front View .....	70
13.4	Radiated Emission above 1 GHz Rear View .....	70
13.5	AC Line Conducted Emission Front View .....	71
13.6	AC Line Conducted Emission Side View.....	71
<b>14</b>	<b>Exhibit C - EUT Photographs .....</b>	<b>72</b>
14.1	EUT Top View.....	72
14.2	EUT Bottom View .....	72
14.3	EUT Front View .....	73
14.4	EUT Rear View .....	73
14.5	EUT Right View .....	74
14.6	EUT Left View .....	74
14.7	EUT Open Case Top View .....	75
14.8	EUT Open Case Bottom View.....	75
14.9	Debugging Board Top View.....	76
14.10	Debugging Board Bottom View .....	76

### DOCUMENT REVISION HISTORY

Revision Number	Report Number	Description of Revision	Date of Revision
0	R1512144-247	Initial	2016-01-27

## 1 General Description

---

### 1.1 Product Description for Equipment Under Test (EUT)

This test and measurement report has been compiled on behalf of *Marvell Semiconductor, Inc.* and their product, *FCC ID: UAYK501, IC: 6549A-K501*, model number: *K5-01*, which henceforth is referred to as the EUT (Equipment under Test). The EUT is used for Develop Internet of Things applications using Kinoma software technology on Marvell mw30x platform.

### 1.2 Mechanical Description of EUT

The EUT measures approximately 44mm (L), 44mm (W), 11mm (H), and weighs approximately 17.5g.

*The data gathered are from a typical production sample provided by the manufacturer with serial number: R1512144-01, assigned by BACL.*

### 1.3 Objective

This report is prepared on behalf of *Marvell Semiconductor, Inc.*, in accordance with Part 2, Subpart J, and Part 15, Subparts B and C of the Federal Communication Commission's rules and IC RSS-247 Issue 1, May 2015.

The objective is to determine compliance with FCC Part 15.247 rules and with IC RSS-247 rules for Output Power, Antenna Requirements, 6 dB Bandwidth, Power Spectral Density, 100 kHz Bandwidth of Band Edges Measurement, Spurious Emissions, Conducted and Radiated Spurious Emissions.

### 1.4 Related Submittal(s)/Grant(s)

N/A

### 1.5 Test Methodology

All measurements contained in this report were conducted in accordance with ANSI C63.10-2013, American National Standard of Procedures for Compliance Testing of Unlicensed Wireless Devices and FCC KDB 558074 D01 DTS Meas Guidance v03r03: Guidance for Performing Compliance Measurements on Digital Transmission Systems (DTS) Operating Under §15.247

### 1.6 Measurement Uncertainty

All measurements involve certain levels of uncertainties, especially in the field of EMC. The factors contributing to uncertainties are spectrum analyzer, cable loss, antenna factor calibration, antenna directivity, antenna factor variation with height, antenna phase center variation, antenna factor frequency interpolation, measurement distance variation, site imperfections, mismatch (average), and system repeatability.

Based on CISPR16-4-2:2011, The Treatment of Uncertainty in EMC Measurements, the values ranging from  $\pm 2.0$  dB for Conducted Emissions tests and  $\pm 4.0$  dB for Radiated Emissions tests are the most accurate estimates pertaining to uncertainty of EMC measurements at BACL Corp.

## 1.7 Test Facility

Bay area compliance Laboratories Corp. (BACL) is:

1- An independent Commercial Test Laboratory accredited to **ISO 17025: 2005** by **A2LA**, in the fields of: Electromagnetic Compatibility & Telecommunications covering Emissions, Immunity, Radio, RF Exposure, Safety and Telecom. This includes NEBS (Network Equipment Building System), Wireless RF, Telecommunications Terminal Equipment (TTE); Network Equipment; Information Technology Equipment (ITE); Medical Electrical Equipment; Industrial, Commercial, and Medical Test Equipment; Professional Audio and Video Equipment; Electronic (Digital) Products; Industrial and Scientific Instruments; Cabled Distribution Systems and Energy Efficiency Lighting.

2- An ENERGY STAR Recognized Laboratory, for the LM80 Testing, a wide variety of Luminaires and Computers.

3- A NIST Designated Phase-I and Phase-II CAB including: ACMA (Australian Communication and Media Authority), BSMI (Bureau of Standards, Metrology and Inspection of Taiwan), IDA (Infocomm Development Authority of Singapore), IC(Industry Canada), Korea ( Ministry of Communications Radio Research Laboratory), NCC (Formerly DGT; Directorate General of Telecommunication of Chinese Taipei) OFTA (Office of the Telecommunications Authority of Hong Kong), Vietnam, VCCI - Voluntary Control Council for Interference of Japan and a designated EU CAB (Conformity Assessment Body) (Notified Body) for the EMC and R&TTE Directives.

4- A Product Certification Body accredited to **ISO Guide 65: 1996** by **A2LA** to certify:

2. Radio Standards Specifications (RSS) in the Category I Equipment Standards List and All Broadcasting Technical Standards (BETS) in Category I Equipment Standards List for Industry Canada.

3. Radio Communication Equipment for Singapore.

4. Radio Equipment Specifications, GMDSS Marine Radio Equipment Specifications, and Fixed Network Equipment Specifications for Hong Kong.

5. Japan MIC Telecommunication Business Law (A1, A2) and Radio Law (B1, B2 and B3).

6. Audio/Video, Battery Charging Systems, Computers, Displays, Enterprise Servers, Imaging Equipment, Set-Top Boxes, Telephony, Televisions, Ceiling Fans, CFLs (Including GU24s), Decorative Light Strings, Integral LED Lamps, Luminaires, Residential Ventilating Fans.

The test site used by BACL Corp. to collect radiated and conducted emissions measurement data is located at its facility in Sunnyvale, California, USA.

The test site at BACL Corp. has been fully described in reports submitted to the Federal Communication Commission (FCC) and Voluntary Control Council for Interference (VCCI). The details of these reports have been found to be in compliance with the requirements of Section 2.948 of the FCC Rules on February 11 and December 10, 1997, and Article 8 of the VCCI regulations on December 25, 1997. The test site also complies with the test methods and procedures set forth in CISPR 22:2008 §10.4 for measurements below 1 GHz and §10.6 for measurements above 1 GHz as well as ANSI C63.3-2013, ANSI C63.4-2014, TIA/EIA-603 & CISPR 24:2010.

The Federal Communications Commission and Voluntary Control Council for Interference have the reports on file and they are listed under FCC registration number: 90464 and VCCI Registration No.: A-0027. The test site has been approved by the FCC and VCCI for public use and is listed in the FCC Public Access Link (PAL) database.

Additionally, BACL Corp. is an American Association for Laboratory Accreditation (A2LA) accredited laboratory (Lab Code 3297-02). The current scope of accreditations can be found at

<http://www.a2la.org/scopepdf/3297-02.pdf?CFID=1132286&CFTOKEN=e42a3240dac3f6ba-6DE17DCB-1851-9E57-477422F667031258&jsessionid=8430d44f1f47cf2996124343c704b367816b>

## 2 System Test Configuration

### 2.1 Justification

The EUT was configured for testing according to ANSI C63.10-2013 and FCC KDB 558074 D01 DTS Meas Guidance v03r03.

The EUT was tested in a testing mode to represent worst-case results during the final qualification test.

The worst-case data rates are determined to be as follows for each mode based upon investigation by measuring the average power, peak power and PPSD across all data rates bandwidths, and modulations.

### 2.2 EUT Exercise Software

The software *Marvell RTOS operating system version 0.90 and Kinoma software version 7.1* was utilized during testing which was provided by *Marvell Semiconductor, Inc.*

*The EUT only operates at 802.11b/g/n20 mode, and only uses 11 channels.*

The Duty cycle of the EUT was greater than 99%

802.11b Duty Cycle

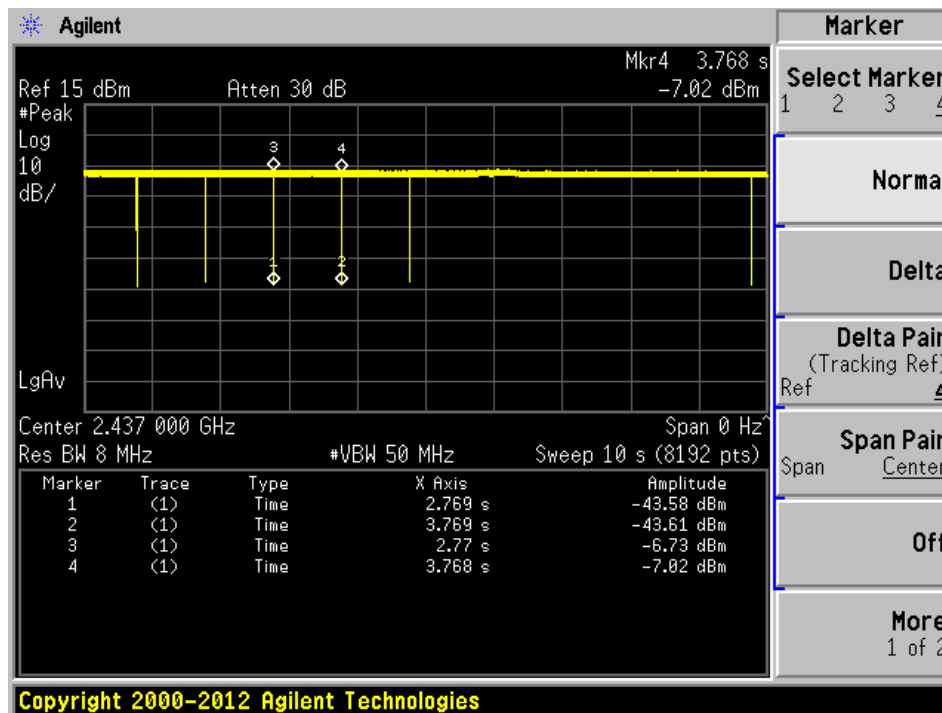

802.11g Duty Cycle

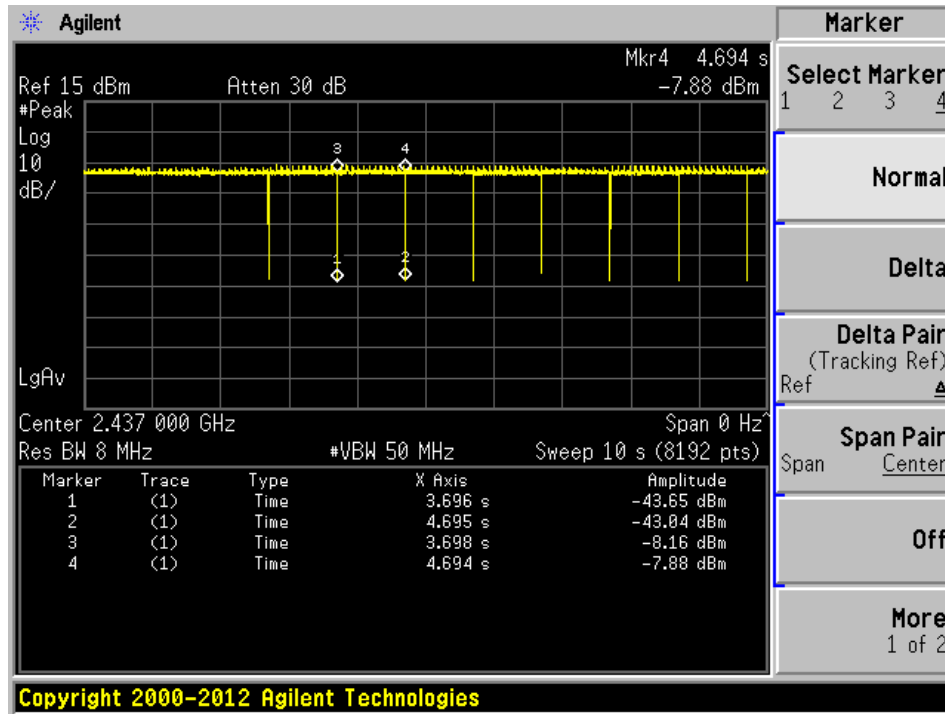

802.11n20 Duty Cycle

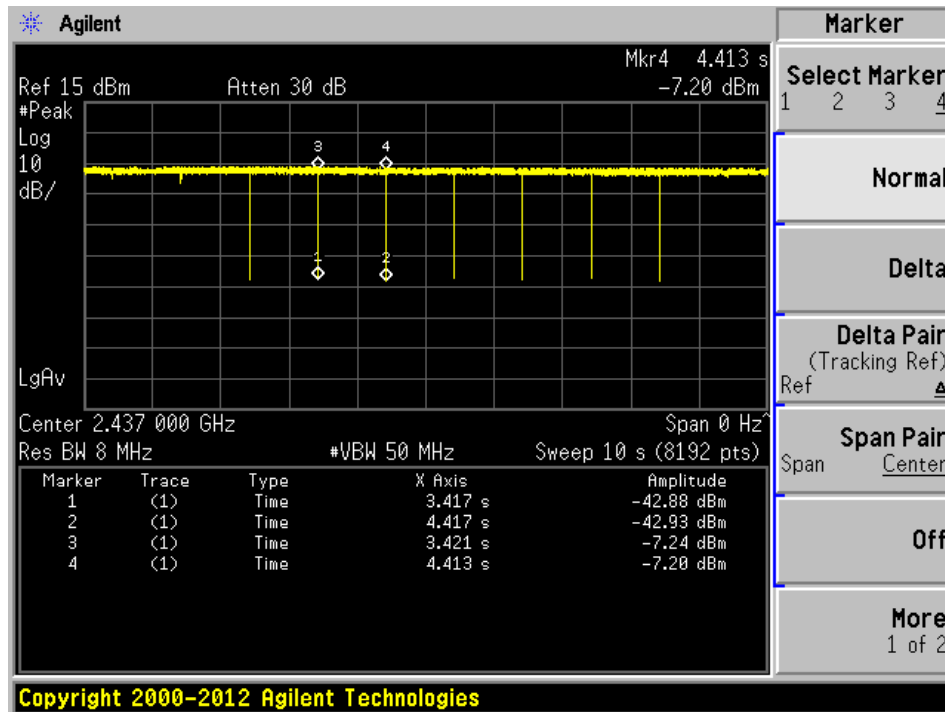



### 2.3 Equipment Modifications

No modifications were made to the EUT.

### 2.4 Local Support Equipment

Manufacturer	Description	Model No.	Serial No.
DELL	Laptop	Latitude D630	-
Marvell Semiconductor	K5-adaptor board	1537MV	-

### 2.5 EUT Internal Configuration Details

Manufacturer/Product Type	Model/Rev.	Crystals (MHz)
Marvell / Kinoma SDK	Element Main board / Rev 4	38.4

### 2.6 Power Supply and Line Filter

N/A

### 2.7 Interface Ports and Cabling

Cable Description	Length (m)	To	From
RF Cable	< 1m	PSA	EUT
Micro USB Cable	< 1m	EUT	Laptop

### 3 Summary of Test Results

Results reported relate only to the product tested.

FCC & IC Rules	Description of Test	Results
FCC §15.203 IC RSS-Gen §8.3	Antenna Requirement	Compliant
FCC §15.207(a) IC RSS-Gen §8.8	AC Line Conducted Emissions	Compliant
FCC §15.247(i) IC RSS-102	RF Exposure	Compliant
FCC §15.247 (d) IC RSS-247 §5.5	Spurious Emissions at Antenna Port	Compliant
FCC §15.205 IC RSS-Gen §8.10	Restricted Bands	Compliant
FCC §15.209, §15.247 (d) IC RSS-247 §5.5 IC RSS-Gen §8.9	Radiated Spurious Emissions	Compliant
FCC §15.247(a)(2) IC RSS-247 §5.2 IC RSS-Gen §6.6	6 dB&99% Emission Bandwidth	Compliant
FCC §15.247(b)(3) IC RSS-247 §5.4	Maximum Peak Output Power	Compliant
FCC §15.247(d) IC RSS-247 §5.5	100 kHz Bandwidth of Frequency Band Edge	Compliant
FCC §15.247(e) IC RSS-247 §5.2	Power Spectral Density	Compliant

## 4 FCC §15.247(i) & IC RSS §102 – RF Exposure

### 4.1 Applicable Standards

According to FCC §15.247(i) and §1.1307(b)(1), systems operating under the provisions of this section shall be operated in a manner that ensures that the public is not exposed to radio frequency energy level in excess of the Commission's guidelines.

#### Limits for General Population/Uncontrolled Exposure

Frequency Range (MHz)	Electric Field Strength (V/m)	Magnetic Field Strength (A/m)	Power Density (mW/cm <sup>2</sup> )	Averaging Time (minutes)
Limits for General Population/Uncontrolled Exposure				
0.3-1.34	614	1.63	* (100)	30
1.34-30	824/f	2.19/f	* (180/f <sup>2</sup> )	30
30-300	27.5	0.073	0.2	30
300-1500	/	/	f/1500	30
1500-100,000	/	/	1.0	30

f = frequency in MHz

\* = Plane-wave equivalent power density

Before equipment certification is granted, the procedure of IC RSS-102 must be followed concerning the exposure of humans to RF field

According to IC RSS-102 Issue 5:

### 2.5.2 Exemption Limits for Routine Evaluation – RF Exposure Evaluation

RF exposure evaluation is required if the separation distance between the user and/or bystander and the device's radiating element is greater than 20 cm, except when the device operates as follows:

- below 20 MHz<sup>6</sup> and the source-based, time-averaged maximum e.i.r.p. of the device is equal to or less than 1 W (adjusted for tune-up tolerance);
- at or above 20 MHz and below 48 MHz and the source-based, time-averaged maximum e.i.r.p. of the device is equal to or less than  $4.49/f^{0.5}$  W (adjusted for tune-up tolerance), where  $f$  is in MHz;
- at or above 48 MHz and below 300 MHz and the source-based, time-averaged maximum e.i.r.p. of the device is equal to or less than 0.6 W (adjusted for tune-up tolerance);
- at or above 300 MHz and below 6 GHz and the source-based, time-averaged maximum e.i.r.p. of the device is equal to or less than  $1.31 \times 10^{-2} f^{0.6834}$  W (adjusted for tune-up tolerance), where  $f$  is in MHz;
- at or above 6 GHz and the source-based, time-averaged maximum e.i.r.p. of the device is equal to or less than 5 W (adjusted for tune-up tolerance).

In these cases, the information contained in the RF exposure technical brief may be limited to information that demonstrates how the e.i.r.p. was derived.

## 4.2 MPE Prediction

Predication of MPE limit at a given distance, Equation from OET Bulletin 65, Edition 97-01

$$S = PG/4\pi R^2$$

Where: S = power density

P = power input to antenna

G = power gain of the antenna in the direction of interest relative to an isotropic radiator

R = distance to the center of radiation of the antenna

## 4.3 MPE Results for FCC

<u>Maximum peak output power at antenna input terminal (dBm):</u>	<u>6.58</u>
<u>Maximum peak output power at antenna input terminal (mW):</u>	<u>4.549881</u>
<u>Prediction distance (cm):</u>	<u>20</u>
<u>Prediction frequency (MHz):</u>	<u>2462</u>
<u>Maximum Antenna Gain, typical (dBi):</u>	<u>0.5</u>
<u>Maximum Antenna Gain (numeric):</u>	<u>1.122</u>
<u>Power density of prediction frequency at 20.0 cm (mW/cm<sup>2</sup>):</u>	<u>0.001016</u>
<u>FCC MPE limit for uncontrolled exposure at prediction frequency (mW/cm<sup>2</sup>):</u>	<u>1.0</u>

The device is compliant with the requirement MPE limit for uncontrolled exposure. The maximum power density at the distance of 20 cm is 0.001016 mW/cm<sup>2</sup>. Limit is 1.0 mW/cm<sup>2</sup>.

## 4.4 RF exposure evaluation exemption for IC

Maximum EIRP power = 6.58 dBm + 0.5 dBi = 7.08 dBm which is lesser than  $1.31 \times 10^{-2} f^{0.6834} = 2.722 \text{ W} = 34.349 \text{ dBm}$

Therefore the RF exposure evaluation is not required.

## 5 FCC §15.203 & IC RSS-Gen §8.3 - Antenna Requirements

### 5.1 Applicable Standards

According to FCC §15.203:

An intentional radiator shall be designed to ensure that no antenna other than that furnished by the responsible party shall be used with the device. The use of a permanently attached antenna or of an antenna that uses a unique coupling to the intentional radiator shall be considered sufficient to comply with the provisions of this Section. The manufacturer may design the unit so that a broken antenna can be replaced by the user, but the use of a standard antenna jack or electrical connector is prohibited.

And according to FCC §15.247 (b) (4), if transmitting antennas of directional gain greater than 6 dBi are used the power shall be reduced by the amount in dB that the directional gain of the antenna exceeds 6 dBi.

According to IC RSS-Gen §8.3: Transmitter Antenna

The applicant for equipment certification, as per RSP-100, must provide a list of all antenna types that may be used with the license-exempt transmitter, indicating the maximum permissible antenna gain (in dBi) and the required impedance for each antenna.

License-exempt transmitters that have received equipment certification may operate with different types of antennas. However, it is not permissible to exceed the maximum equivalent isotropically radiated power (e.i.r.p.) limits specified in the applicable standard (RSS) for the license-exempt apparatus.

Testing shall be performed using the highest gain antenna of each combination of license-exempt transmitter and antenna type, with the transmitter output power set at the maximum level. 9 When a measurement at the antenna connector is used to determine RF output power, the effective gain of the device's antenna shall be stated, based on a measurement or on data from the antenna manufacturer.

User manuals for transmitters equipped with detachable antennas shall also contain the following notice in a conspicuous location:

This radio transmitter (identify the device by certification number) has been approved by Industry Canada to operate with the antenna types listed below with the maximum permissible gain indicated. Antenna types not included in this list, having a gain greater than the maximum gain indicated for that type, are strictly prohibited for use with this device.

Immediately following the above notice, the manufacturer shall provide a list of all antenna types approved for use with the transmitter, indicating the maximum permissible antenna gain (in dBi).

### 5.2 Antenna List and Details

Frequency Range (MHz)	External/Internal/Integral	Max Gain (dBi)	Antenna Type/Pattern
2400-2500	Integrated	0.5	Chip antenna/Omni directional

## 6 FCC §15.207 & IC RSS-Gen §8.8 – AC Line Conducted Emissions

### 6.1 Applicable Standards

As per FCC §15.207 and IC RSS-Gen §8.8 conducted limits:

For an intentional radiator that is designed to be connected to the public utility (AC) power line, the radio frequency voltage that is conducted back onto the AC power line on any frequency or frequencies within the band 150 kHz to 30 MHz shall not exceed the limits in the following table, as measured using a 50  $\mu$ H/50 ohms line impedance stabilization network (LISN). Compliance with the provisions of this paragraph shall be based on the measurement of the radio frequency voltage between each power line and ground at the power terminal. The lower limit applies at the boundary between the frequencies ranges.

Frequency of Emission (MHz)	Conducted Limit (dBUV)	
	Quasi-Peak	Average
0.15-0.5	66 to 56 <sup>Note</sup>	56 to 46 <sup>Note</sup>
0.5-5	56	46
5-30	60	50

*Note: Decreases with the logarithm of the frequency.*

### 6.2 Test Setup

The measurement was performed at shield room, using the setup per ANSI C63.4-2014 measurement procedure. The specification used was FCC §15.207 and IC RSS-Gen §8.8 limits.

External I/O cables were draped along the edge of the test table and bundle when necessary.

The AC/DC power adapter of the EUT was connected with LISN-1 which provided 120 V / 60 Hz AC power.

### 6.3 Test Procedure

During the conducted emissions test, the power cord of the EUT host system was connected to the mains outlet of the LISN-1 and the power cord of the support equipment was connected to LISN-2.

Maximizing procedure was performed on the six (6) highest emissions of the EUT.

All data was recorded in the peak detection mode, quasi-peak and average. Quasi-Peak readings are distinguished with a “QP.” Average readings are distinguished with an “Ave”.

## 6.4 Test Setup Block Diagram

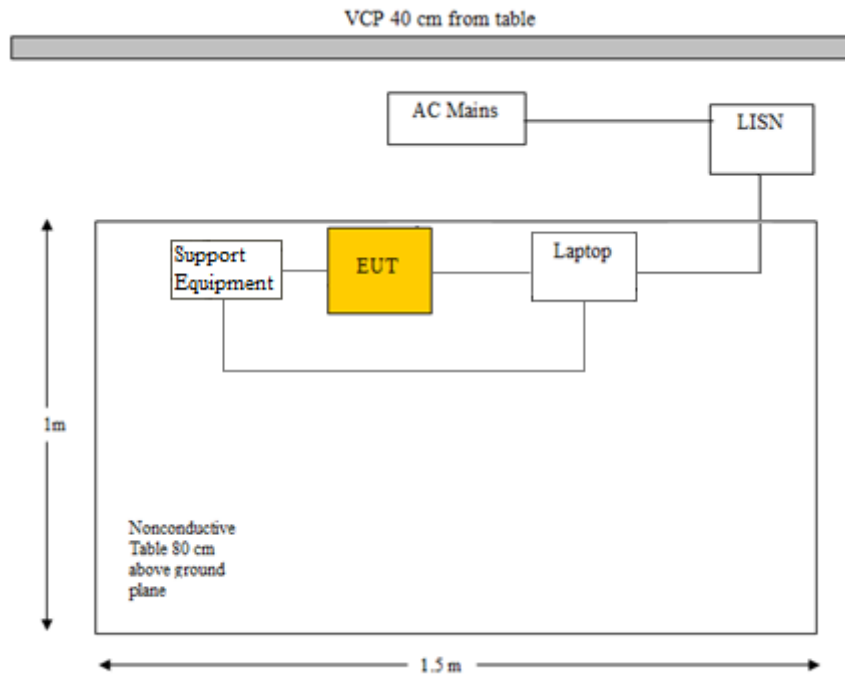

## 6.5 Corrected Amplitude & Margin Calculation

The Corrected Amplitude (CA) is calculated by adding the Cable Loss (CL), the Attenuator Factor (Atten) to indicated Amplitude ( $A_i$ ) reading. The basic equation is as follows:

$$CA = A_i + CL + \text{Atten}$$

For example, a corrected amplitude of 46.2 dBuV = Indicated Reading (32.5 dBuV) + Cable Loss (3.7 dB) + Attenuator (10 dB)

The “**Margin**” column of the following data tables indicates the degree of compliance within the applicable limit. For example, a margin of -7 dB means the emission is 7 dB below the maximum limit. The equation for margin calculation is as follows:

$$\text{Margin} = \text{Corrected Amplitude} - \text{Limit}$$

## 6.6 Test Equipment List and Details

Manufacturer	Description	Model No.	Serial No.	Calibration Date	Calibration Interval
Rohde & Schwarz	EMI Test Receiver	ESCI 1166.5950K03	100337	2015-09-28	1 year
FCC	LISN	FCC-LISN-50-25-2-10-CISPR16	160129	2015-04-17	1 year
TTE	Filter, High Pass	H962-150k-50-21378	K7133	2015-01-30	1 year
Suirong	30 ft conductive emission cable	LMR 400	-	2015-03-05	1 year
Hewlett-Packard	5 ft RF cable	-	1268	2015-07-29	1 year

**Statement of Traceability:** *BACL Corp.* attests that all calibrations have been performed per the A2LA requirements, traceable to the NIST.

## 6.7 Test Environmental Conditions

<b>Temperature:</b>	24 °C
<b>Relative Humidity:</b>	43 %
<b>ATM Pressure:</b>	102.5 kPa

The testing was performed by Leonard Gray on 2015-12-28 in 5m chamber3.

## 6.8 Summary of Test Results

According to the recorded data in following table, the EUT complied with the FCC 15C and IC RSS-Gen standard's conducted emissions limits, with the margin reading of:

Connection: Laptop AC/DC adapter connected to 120 V/60 Hz, AC			
Margin (dB)	Frequency (MHz)	Conductor Mode (Line/Neutral)	Range (MHz)
-8.32	0.155958	Neutral	0.15-30



### 6.9 Conducted Emissions Test Plots and Data

#### 120 V, 60 Hz – Line

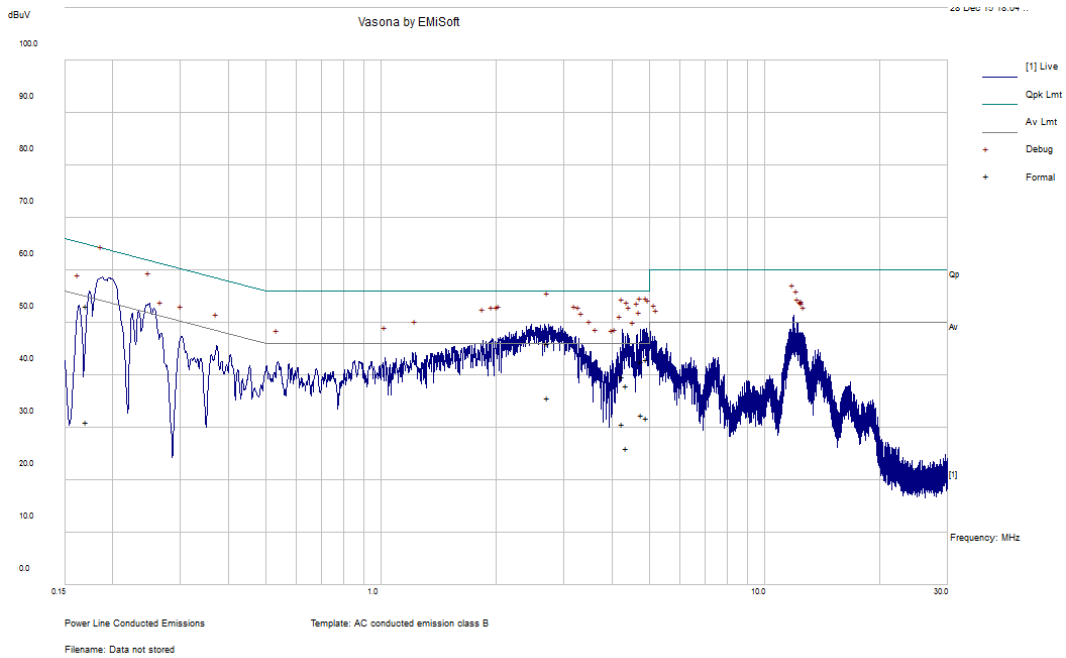

Frequency (MHz)	Corrected Amplitude (dBμV)	Conductor (Line/Neutral)	Limit (dBμV)	Margin (dB)	Detector (QP/Ave.)
0.170292	53.18	Line	64.95	-11.76	QP
2.726317	46.14	Line	56	-9.86	QP
4.93007	43.05	Line	56	-12.95	QP
4.771355	42.66	Line	56	-13.34	QP
4.275389	39.73	Line	56	-16.27	QP
4.373984	37.93	Line	56	-18.07	QP

Frequency (MHz)	Corrected Amplitude (dBμV)	Conductor (Line/Neutral)	Limit (dBμV)	Margin (dB)	Detector (QP/Ave.)
0.170292	31.18	Line	54.95	-23.77	Ave
2.726317	35.64	Line	46	-10.36	Ave
4.93007	31.86	Line	46	-14.14	Ave
4.771355	32.43	Line	46	-13.57	Ave
4.275389	30.74	Line	46	-15.26	Ave
4.373984	26.09	Line	46	-19.91	Ave

**120 V, 60 Hz – Neutral**

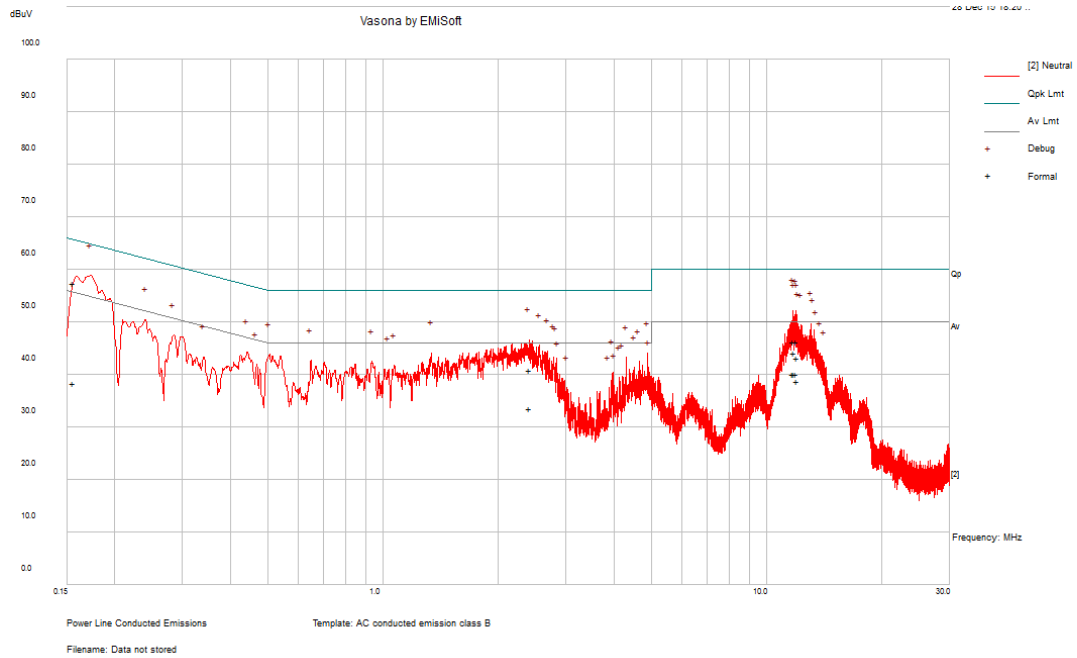

Frequency (MHz)	Corrected Amplitude (dBµV)	Conductor (Line/Neutral)	Limit (dBµV)	Margin (dB)	Detector (QP/Ave.)
0.155958	57.35	Neutral	65.68	-8.32	QP
11.70069	46.26	Neutral	60	-13.74	QP
11.91667	46.3	Neutral	60	-13.7	QP
11.80786	44.14	Neutral	60	-15.86	QP
12.00836	43.13	Neutral	60	-16.87	QP
2.408712	40.97	Neutral	56	-15.03	QP

Frequency (MHz)	Corrected Amplitude (dBµV)	Conductor (Line/Neutral)	Limit (dBµV)	Margin (dB)	Detector (QP/Ave.)
0.155958	38.48	Neutral	55.68	-17.19	Ave
11.70069	40.12	Neutral	50	-9.88	Ave
11.91667	40.09	Neutral	50	-9.91	Ave
11.80786	40.15	Neutral	50	-9.85	Ave
12.00836	38.85	Neutral	50	-11.15	Ave
2.408712	33.52	Neutral	46	-12.48	Ave

## 7 FCC §15.209, §15.247(d) & IC RSS-247 §5.5, RSS-Gen §8.9, §8.10 - Spurious Radiated Emissions

### 7.1 Applicable Standards

As per FCC §15.35(d): Unless otherwise specified, on any frequency or frequencies above 1000 MHz, the radiated emission limits are based on the use of measurement instrumentation employing an average detector function. Unless otherwise specified, measurements above 1000 MHz shall be performed using a minimum resolution bandwidth of 1 MHz.

As per FCC §15.209(a): Except as provided elsewhere in this Subpart, the emissions from an intentional radiator shall not exceed the field strength levels specified in the following table

Frequency (MHz)	Field Strength (micro volts/meter)	Measurement Distance (meters)
0.009 - 0.490	2400/F(kHz)	300
0.490 - 1.705	24000/F(kHz)	30
1.705 - 30.0	30	30
30 - 88	100**	3
88 - 216	150**	3
216 - 960	200**	3
Above 960	500	3

\*\* Except as provided in paragraph (g), fundamental emissions from intentional radiators operating under this Section shall not be located in the frequency bands 54-72 MHz, 76-88 MHz, 174-216 MHz or 470-806 MHz. However, operation within these frequency bands is permitted under other sections of this Part, e.g., Sections 15.231 and 15.241.

As Per FCC §15.205(a) except as show in paragraph (d) of this section, only spurious emissions are permitted in any of the frequency bands listed below:

MHz	MHz	MHz	GHz
0.090 – 0.110	16.42 – 16.423	960 – 1240	4.5 – 5.15
0.495 – 0.505	16.69475 – 16.69525	1300 – 1427	5.35 – 5.46
2.1735 – 2.1905	25.5 – 25.67	1435 – 1626.5	7.25 – 7.75
4.125 – 4.128	37.5 – 38.25	1645.5 – 1646.5	8.025 – 8.5
4.17725 – 4.17775	73 – 74.6	1660 – 1710	9.0 – 9.2
4.20725 – 4.20775	74.8 – 75.2	1718.8 – 1722.2	9.3 – 9.5
6.215 – 6.218	108 – 121.94	2200 – 2300	10.6 – 12.7
6.26775 – 6.26825	123 – 138	2310 – 2390	13.25 – 13.4
6.31175 – 6.31225	149.9 – 150.05	2483.5 – 2500	14.47 – 14.5
8.291 – 8.294	156.52475 – 156.52525	2690 – 2900	15.35 – 16.2
8.362 – 8.366	156.7 – 156.9	3260 – 3267	17.7 – 21.4
8.37625 – 8.38675	162.0125 – 167.17	3.332 – 3.339	22.01 – 23.12
8.41425 – 8.41475	167.72 – 173.2	3 3458 – 3 358	23.6 – 24.0
12.29 – 12.293	240 – 285	3.600 – 4.400	31.2 – 31.8
12.51975 – 12.52025	322 – 335.4		36.43 – 36.5
12.57675 – 12.57725	399.9 – 410		Above 38.6
13.36 – 13.41	608 – 614		

As per FCC §15.247 (d) In any 100 kHz bandwidth outside the frequency band in which the spread spectrum or digitally modulated intentional radiator is operating, the radio frequency power that is produced by the intentional radiator shall be at least 20 dB below that in the 100 kHz bandwidth within the band that contains the highest level of the desired power, based on either an RF conducted or a radiated measurement, provided the transmitter demonstrates compliance with the peak conducted power limits. If the transmitter complies with the conducted power limits based on the use of RMS averaging over a time interval, as permitted under paragraph (b)(3) of this section, the attenuation required under this paragraph shall be 30 dB instead of 20 dB. Attenuation below the general limits specified in §15.209(a) is not required. In addition, radiated emissions which fall in the restricted bands, as defined in §15.205(a), must also comply with the radiated emission limits specified in §15.209(a) (see §15.205(c)).

As per IC RSS-Gen 8.9,

Except when the requirements applicable to a given device state otherwise, emissions from licence-exempt transmitters shall comply with the field strength limits shown in Table 4 or Table 5 below. Additionally, the level of any transmitter emission shall not exceed the level of the transmitter's fundamental emission.

**Table 4 – General Field Strength Limits for Licence-Exempt Transmitters at Frequencies Above 30 MHz**

Frequency (MHz)	Field Strength ( $\mu\text{v/m}$ at 3 metres)
30-88	100
88-216	150
216-960	200
Above 960*	500

\* Unless otherwise specified, for all frequencies greater than 1 GHz, the radiated emission limits for licence-exempt radio apparatus stated in applicable RSSs (including RSS-Gen) are based on measurements using a linear average detector function having a minimum resolution bandwidth of 1 MHz. If an average limit is specified for the EUT, then the peak emission shall also be measured with instrumentation properly adjusted for such factors as pulse desensitization to ensure the peak emission is less than 20 dB above the average limit.

Note: Transmitting devices are not permitted in restricted frequency bands unless stated otherwise in the specific RSS.

As per IC RSS-247 5.5, in any 100 kHz bandwidth outside the frequency band in which the spread spectrum or digitally modulated device is operating, the RF power that is produced shall be at least 20 dB below that in the 100 kHz bandwidth within the band that contains the highest level of the desired power, based on either an RF conducted or a radiated measurement, provided that the transmitter demonstrates compliance with the peak conducted power limits. If the transmitter complies with the conducted power limits based on the use of root-mean-square averaging over a time interval, as permitted under Section 5.4(4), the attenuation required shall be 30 dB instead of 20 dB. Attenuation below the general field strength limits specified in RSS-Gen is not required.

As per IC RSS-Gen 8.10, Restricted bands, identified in Table 6, are designated primarily for safety-of-life services (distress calling and certain aeronautical bands), certain satellite downlinks, radio astronomy and some government uses. Except where otherwise indicated, the following restrictions apply: (a) Fundamental components of modulation of licence-exempt radio apparatus shall not fall within the restricted bands of Table 6 except for apparatus complying under RSS-287; (b) Unwanted emissions that fall into restricted bands of Table 6 shall comply with the limits specified in RSS-Gen; and (c) Unwanted emissions that do not fall within the restricted frequency bands of Table 6 shall comply either with the limits specified in the applicable RSS or with those specified in this RSS-Gen.

**Table 6 – Restricted Frequency Bands\***

MHz	MHz	GHz
0.090-0.110	240-285	9.0-9.2
2.1735-2.1905	322-335.4	9.3-9.5
3.020-3.026	399.9-410	10.6-12.7
4.125-4.128	608-614	13.25-13.4
4.17725-4.17775	960-1427	14.47-14.5
4.20725-4.20775	1435-1626.5	15.35-16.2
5.677-5.683	1645.5-1646.5	17.7-21.4
6.215-6.218	1660-1710	22.01-23.12
6.26775-6.26825	1718.8-1722.2	23.6-24.0
6.31175-6.31225	2200-2300	31.2-31.8
8.291-8.294	2310-2390	36.43-36.5
8.362-8.366	2655-2900	Above 38.6
8.37625-8.38675	3260-3267	
8.41425-8.41475	3332-3339	
12.29-12.293	3345.8-3358	
12.51975-12.52025	3500-4400	
12.57675-12.57725	4500-5150	
13.36-13.41	5350-5460	
16.42-16.423	7250-7750	
16.69475-16.69525	8025-8500	
16.80425-16.80475		
25.5-25.67		
37.5-38.25		
73-74.6		
74.8-75.2		
108-138		
156.52475-156.52525		
156.7-156.9		

\* Certain frequency bands listed in Table 6 and in bands above 38.6 GHz are designated for licence-exempt applications. These frequency bands and the requirements that apply to the devices are set out in the 200- and 300-series of RSSs, such as RSS-210 and RSS-310, which contain the requirements that apply to licence-exempt radio apparatus.

## 7.2 Test Setup

The radiated emissions tests were performed in the 5-meter Chamber, using the setup in accordance with ANSI C63.10-2013. The specification used was the FCC 15 Subpart C/IC RSS-247 limits.

The spacing between the peripherals was 10 centimeters.

External I/O cables were draped along the edge of the test table and bundle when necessary.

## 7.3 Test Procedure

For the radiated emissions test, the EUT host, and all support equipment power cords was connected to the AC floor outlet.

Maximizing procedure was performed on the highest emissions to ensure that the EUT complied with all installation combinations.

The EUT is set 3 meter away from the testing antenna, which is varied from 1-4 meter, and the EUT is placed on a turntable, which is 0.8 meter above ground plane, the table shall be rotated for 360 degrees to find out the highest emission. The receiving antenna should be changed the polarization both of horizontal and vertical.

The spectrum analyzer or receiver is set as:

Below 1000 MHz:

$$\text{RBW} = 100 \text{ kHz} / \text{VBW} = 300 \text{ kHz} / \text{Sweep} = \text{Auto}$$

Above 1000 MHz:

- (1) Peak: RBW = 1MHz / VBW = 1MHz / Sweep = Auto
- (2) Average: RBW = 1MHz / VBW = 10Hz / Sweep = Auto

## 7.4 Corrected Amplitude & Margin Calculation

The Corrected Amplitude (CA) is calculated by adding the Antenna Factor (AF), the Cable Loss (CL), the Attenuator Factor (Atten) and subtracting the Amplifier Gain (Ga) to indicated Amplitude (Ai) reading. The basic equation is as follows:

$$\text{CA} = \text{Ai} + \text{AF} + \text{CL} + \text{Atten} - \text{Ga}$$

For example, a corrected amplitude of 40.3 dBuV/m = Indicated Reading (32.5 dBuV) + Antenna Factor (+23.5dB) + Cable Loss (3.7 dB) + Attenuator (10 dB) - Amplifier Gain (29.4 dB)

The “**Margin**” column of the following data tables indicates the degree of compliance within the applicable limit. For example, a margin of -7 dB means the emission is 7 dB below the maximum limit. The equation for margin calculation is as follows:

$$\text{Margin} = \text{Corrected Amplitude} - \text{Limit}$$

## 7.5 Test Equipment List and Details

Manufacturer	Description	Model No.	Serial No.	Calibration Date	Calibration Interval
Rohde & Schwarz	EMI Test Receiver	ESCI 1166.5950K03	100338	2014-01-20	2 year
Agilent	Spectrum Analyzer	E4440A	MY44303352	2015-06-22	1 year
Sunol Science Corp	System Controller	SC99V	011003-1	N/R	N/R
Sunol Sciences	Antenna, Biconi-Log	JB1	A013105-3	2015-07-11	2 year
A.R.A	Antenna, Horn	DRG-118/A	1132	2015-09-21	2 year
HP	Pre-Amplifier	8447D	2944A06639	2015-06-08	1 year
Suirong	30 ft conductive emission cable	LMR 400	-	2015-03-05	1 year
-	SMA cable	-	C0001	Each time <sup>1</sup>	N/A
IW Microwave	High Frequency Cable	DC-1531	KPS-1501A3960KPS	2015-08-10	1 year
Agilent	Pre-Amplifier	8449B	3008A01978	2015-09-02	1 year

Note<sup>1</sup>: cable and attenuator included in the test set-up will be checked each time before testing.

**Statement of Traceability:** *BACL attests that all calibrations have been performed per the A2LA requirements, traceable to NIST.*

## 7.6 Test Environmental Conditions

<b>Temperature:</b>	20-25 °C
<b>Relative Humidity:</b>	40-45 %
<b>ATM Pressure:</b>	101.2-103.5 kPa

The testing was performed by Leonard Gray on 2015-12-23 in 5m chamber3.

## 7.7 Summary of Test Results

According to the data hereinafter, the EUT complied with the FCC Title 47, Part 15C and IC RSS-247 standard's radiated emissions limits, and had the worst margin of:

Mode: Transmitting			
Margin (dB)	Frequency (MHz)	Polarization (Horizontal/Vertical)	Mode, Channel
-2.95	264.0123	Horizontal	802.11b High Channel

Please refer to the following table and plots for specific test result details

### 7.8 Radiated Emissions Test Data and Plots

#### 1) 30 MHz – 1 GHz

Worst Case: 802.11b High Channel

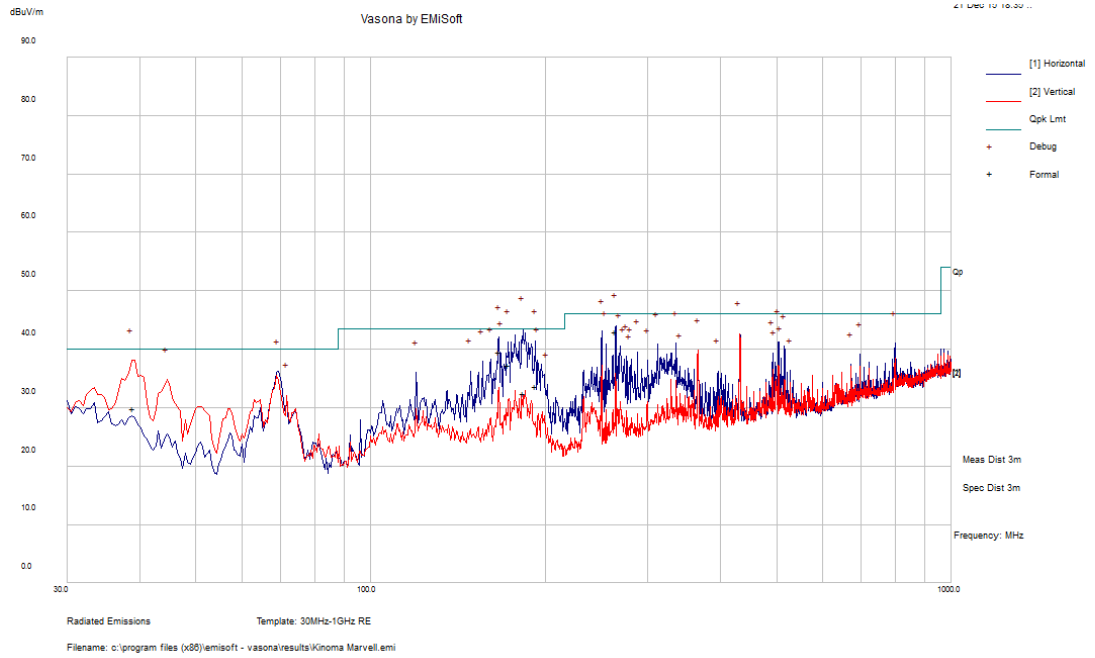

Frequency (MHz)	Corrected Amplitude (dBµV/m)	Antenna Height (cm)	Antenna Polarity (H/V)	Turntable Azimuth (degrees)	Limit (dBµV/m)	Margin (dB)	Comments (PK/QP/Ave.)
182.9985	32.43	125	H	77	43.5	-11.07	QP
166.5218	39.51	192	H	98	43.5	-3.99	QP
38.96925	29.88	165	V	198	40	-10.12	QP
264.0123	43.05	113	H	228	46	-2.95	QP
191.995	33.66	131	H	80	43.5	-9.84	QP
172.7825	37.29	116	H	77	43.5	-6.21	QP



## 2) 1 – 25 GHz

## 802.11b Mode

Frequency (MHz)	S.A. Reading (dBµV)	Turntable Azimuth (degrees)	Test Antenna			Cable Loss (dB)	Pre-Amp. (dB)	Cord. Reading (dBµV/m)	FCC/IC		Comments
			Height (cm)	Polarity (H/V)	Factor (dB/m)				Limit (dBµV/m)	Margin (dB)	
Low Channel 2412 MHz											
2412	66.47	177	300	V	28.45	3.43	0.00	98.35	-	-	Peak
2412	70.61	81	213	H	29.04	3.43	0.00	103.08	-	-	Peak
2412	62.69	177	300	V	28.45	3.43	0.00	94.57	-	-	Ave
2412	66.77	81	213	H	29.04	3.43	0.00	99.24	-	-	Ave
2390	25.11	177	300	V	28.45	3.43	0.00	56.99	74.00	-17.01	Peak
2390	25.36	81	213	H	29.04	3.43	0.00	57.83	74.00	-16.17	Peak
2390	12.11	177	300	V	28.45	3.43	0.00	43.99	54.00	-10.01	Ave
2390	12.242	81	213	H	29.04	3.430	0.00	44.71	54.00	-9.29	Ave
4824	47.15	204	190	V	32.89	4.297	35.86	48.48	74.00	-25.52	Peak
4824	49.06	352	268	H	32.74	4.297	35.86	50.24	74.00	-23.76	Peak
4824	34.43	204	190	V	32.89	4.297	35.86	35.76	54.00	-18.24	Ave
4824	41.62	352	268	H	32.74	4.297	35.86	42.80	54.00	-11.20	Ave
7236	45.89	274	223	V	36.25	5.675	36.01	51.81	74.00	-22.19	Peak
7236	46.75	21	130	H	36.14	5.675	36.01	52.55	74.00	-21.45	Peak
7236	31.39	274	223	V	36.25	5.675	36.01	37.31	54.00	-16.69	Ave
7236	34.7	21	130	H	36.14	5.675	36.01	40.50	54.00	-13.50	Ave
9648	46.27	0	100	V	38.00	8.704	36.04	56.93	74.00	-17.07	Peak
9648	45.59	0	100	H	37.92	8.704	36.04	56.17	74.00	-17.83	Peak
9648	31.44	0	100	V	38.00	8.704	36.04	42.10	54.00	-11.90	Ave
9648	31.26	0	100	H	37.92	8.704	36.04	41.84	54.00	-12.16	Ave
Middle Channel 2437 MHz											
2437	66.38	174	291	V	28.348	3.430	0.00	98.16	-	-	Peak
2437	71.44	211	132	H	28.200	3.430	0.00	103.07	-	-	Peak
2437	62.6	174	291	V	28.348	3.430	0.00	94.38	-	-	Ave
2437	67.47	211	132	H	28.200	3.430	0.00	99.10	-	-	Ave
4874	47.74	157	222	V	33.295	4.404	35.90	49.54	74.00	-24.46	Peak
4874	49.12	333	234	H	32.932	4.404	35.90	50.56	74.00	-23.44	Peak
4874	37.32	157	222	V	33.295	4.404	35.90	39.12	54.00	-14.88	Ave
4874	39.76	333	234	H	32.932	4.404	35.90	41.20	54.00	-12.80	Ave
7311	45.89	0	100	V	36.694	5.788	35.96	52.41	74.00	-21.59	Peak
7311	45.64	46	250	H	36.575	5.788	35.96	52.05	74.00	-21.95	Peak
7311	30.56	0	100	V	36.694	5.788	35.96	37.08	54.00	-16.92	Ave
7311	32.06	46	250	H	36.575	5.788	35.96	38.47	54.00	-15.53	Ave
9748	44.92	0	100	V	38.128	8.157	36.03	55.17	74.00	-18.83	Peak
9748	45.02	0	100	H	37.896	8.157	36.03	55.04	74.00	-18.96	Peak
9748	31.24	0	100	V	38.128	8.157	36.03	41.49	54.00	-12.51	Ave
9748	31.31	0	100	H	37.896	8.157	36.03	41.33	54.00	-12.67	Ave

Frequency (MHz)	S.A. Reading (dB $\mu$ V)	Turntable Azimuth (degrees)	Test Antenna			Cable Loss (dB)	Pre-Amp. (dB)	Cord. Reading (dB $\mu$ V/m)	FCC/IC		Comments
			Height (cm)	Polarity (H/V)	Factor (dB/m)				Limit (dB $\mu$ V/m)	Margin (dB)	
High Channel 2462 MHz											
2462	65.81	178	260	V	28.61	3.43	0.00	97.85	-	-	Peak
2462	70.12	83	206	H	28.52	3.43	0.00	102.07	-	-	Peak
2462	61.72	178	260	V	28.61	3.43	0.00	93.76	-	-	Ave
2462	66.24	83	206	H	28.52	3.43	0.00	98.19	-	-	Ave
2483.5	26.55	178	260	V	28.61	3.43	0.00	58.59	74.00	-15.41	Peak
2483.5	26.92	83	206	H	28.52	3.43	0.00	58.87	74.00	-15.14	Peak
2483.5	12.48	178	260	V	28.61	3.43	0.00	44.52	54.00	-9.48	Ave
2483.5	12.54	83	206	H	28.52	3.43	0.00	44.49	54.00	-9.52	Ave
4924	46.23	178	206	V	33.32	4.485	35.91	48.12	74.00	-25.88	Peak
4924	48.2	309	142	H	33.24	4.485	35.91	50.02	74.00	-23.98	Peak
4924	32.79	178	206	V	33.32	4.485	35.91	34.68	54.00	-19.32	Ave
4924	35.83	309	142	H	33.24	4.485	35.91	37.65	54.00	-16.35	Ave
7386	45.32	0	100	V	36.88	5.869	35.96	52.11	74.00	-21.89	Peak
7386	45.42	0	100	H	36.76	5.869	35.96	52.08	74.00	-21.92	Peak
7386	30.29	0	100	V	36.88	5.869	35.96	37.08	54.00	-16.92	Ave
7386	30.54	0	100	H	36.76	5.869	35.96	37.20	54.00	-16.80	Ave
9848	44.03	0	100	V	38.36	7.444	35.98	53.86	74.00	-20.14	Peak
9848	44.2	0	100	H	38.37	7.444	35.98	54.04	74.00	-19.96	Peak
9848	31.34	0	100	V	38.36	7.444	35.98	41.17	54.00	-12.83	Ave
9848	31.35	0	100	H	38.37	7.444	35.98	41.19	54.00	-12.81	Ave

## 802.11g Mode

Frequency (MHz)	S.A. Reading (dBμV)	Turntable Azimuth (degrees)	Test Antenna			Cable Loss (dB)	Pre-Amp. (dB)	Cord. Reading (dBμV/m)	FCC/IC		Comments
			Height (cm)	Polarity (H/V)	Factor (dB/m)				Limit (dBμV/m)	Margin (dB)	
Low Channel 2412 MHz											
2412	66.92	177	299	V	28.45	3.43	0.00	98.80	-	-	Peak
2412	69.96	68	247	H	29.04	3.43	0.00	102.43	-	-	Peak
2412	56.55	177	299	V	28.45	3.43	0.00	88.43	-	-	Ave
2412	59.64	68	247	H	29.04	3.43	0.00	92.11	-	-	Ave
2390	26.96	177	299	V	28.45	3.43	0.00	58.84	74.00	-15.16	Peak
2390	28.45	68	247	H	29.04	3.43	0.00	60.92	74.00	-13.08	Peak
2390	13.41	177	299	V	28.45	3.43	0.00	45.29	54.00	-8.71	Ave
2390	14.14	68	247	H	29.04	3.430	0.00	46.61	54.00	-7.39	Ave
4824	45.75	99	272	V	32.89	4.297	35.86	47.08	74.00	-26.92	Peak
4824	46.83	333	259	H	32.74	4.297	35.86	48.01	74.00	-25.99	Peak
4824	31.18	99	272	V	32.89	4.297	35.86	32.51	54.00	-21.49	Ave
4824	32.23	333	259	H	32.74	4.297	35.86	33.41	54.00	-20.59	Ave
7236	45.15	9	204	V	36.25	5.675	36.01	51.07	74.00	-22.93	Peak
7236	48.84	26	258	H	36.14	5.675	36.01	54.64	74.00	-19.36	Peak
7236	30.21	9	204	V	36.25	5.675	36.01	36.13	54.00	-17.87	Ave
7236	31.87	26	258	H	36.14	5.675	36.01	37.67	54.00	-16.33	Ave
9648	43.55	0	100	V	38.00	8.704	36.04	54.21	74.00	-19.79	Peak
9648	43.47	0	100	H	37.92	8.704	36.04	54.05	74.00	-19.95	Peak
9648	29.6	0	100	V	38.00	8.704	36.04	40.26	54.00	-13.74	Ave
9648	29.28	0	100	H	37.92	8.704	36.04	39.86	54.00	-14.14	Ave
Middle Channel 2437 MHz											
2437	66.45	185	267	V	28.348	3.430	0.00	98.23	-	-	Peak
2437	70.81	215	129	H	28.200	3.430	0.00	102.44	-	-	Peak
2437	56.03	185	267	V	28.348	3.430	0.00	87.81	-	-	Ave
2437	60.33	215	129	H	28.200	3.430	0.00	91.96	-	-	Ave
4874	46.41	138	281	V	33.295	4.404	35.90	48.21	74.00	-25.79	Peak
4874	47.22	191	200	H	32.932	4.404	35.90	48.66	74.00	-25.34	Peak
4874	31.42	138	281	V	33.295	4.404	35.90	33.22	54.00	-20.78	Ave
4874	32.1	191	200	H	32.932	4.404	35.90	33.54	54.00	-20.46	Ave
7311	43.93	0	100	V	36.694	5.788	35.96	50.45	74.00	-23.55	Peak
7311	45.96	0	100	H	36.575	5.788	35.96	52.37	74.00	-21.63	Peak
7311	30.37	0	100	V	36.694	5.788	35.96	36.89	54.00	-17.11	Ave
7311	30.43	0	100	H	36.575	5.788	35.96	36.84	54.00	-17.16	Ave
9748	45.21	0	100	V	38.128	8.157	36.03	55.46	74.00	-18.54	Peak
9748	45.16	0	100	H	37.896	8.157	36.03	55.18	74.00	-18.82	Peak
9748	30.58	0	100	V	38.128	8.157	36.03	40.83	54.00	-13.17	Ave
9748	30.38	0	100	H	37.896	8.157	36.03	40.40	54.00	-13.60	Ave

Frequency (MHz)	S.A. Reading (dB $\mu$ V)	Turntable Azimuth (degrees)	Test Antenna			Cable Loss (dB)	Pre-Amp. (dB)	Cord. Reading (dB $\mu$ V/m)	FCC/IC		Comments
			Height (cm)	Polarity (H/V)	Factor (dB/m)				Limit (dB $\mu$ V/m)	Margin (dB)	
High Channel 2462 MHz											
2462	65.24	131	202	V	28.61	3.43	0.00	97.28	-	-	Peak
2462	70.57	82	296	H	28.52	3.43	0.00	102.52	-	-	Peak
2462	54.49	131	202	V	28.61	3.43	0.00	86.53	-	-	Ave
2462	59.89	82	296	H	28.52	3.43	0.00	91.84	-	-	Ave
2483.5	28.43	131	202	V	28.61	3.43	0.00	60.47	74.00	-13.53	Peak
2483.5	32.28	82	296	H	28.52	3.43	0.00	64.23	74.00	-9.77	Peak
2483.5	13.42	131	202	V	28.61	3.43	0.00	45.46	54.00	-8.54	Ave
2483.5	14.43	82	296	H	28.52	3.43	0.00	46.38	54.00	-7.63	Ave
4924	45.43	321	274	V	33.32	4.485	35.91	47.32	74.00	-26.68	Peak
4924	45.51	23	232	H	33.24	4.485	35.91	47.33	74.00	-26.67	Peak
4924	31.45	321	274	V	33.32	4.485	35.91	33.34	54.00	-20.66	Ave
4924	31.39	23	232	H	33.24	4.485	35.91	33.21	54.00	-20.79	Ave
7386	45.19	0	100	V	36.88	5.869	35.96	51.98	74.00	-22.02	Peak
7386	44.67	0	100	H	36.76	5.869	35.96	51.33	74.00	-22.67	Peak
7386	30.16	0	100	V	36.88	5.869	35.96	36.95	54.00	-17.05	Ave
7386	30.39	0	100	H	36.76	5.869	35.96	37.05	54.00	-16.95	Ave
9848	42.41	0	100	V	38.36	7.444	35.98	52.24	74.00	-21.76	Peak
9848	43.68	0	100	H	38.37	7.444	35.98	53.52	74.00	-20.48	Peak
9848	30.41	0	100	V	38.36	7.444	35.98	40.24	54.00	-13.76	Ave
9848	30.19	0	100	H	38.37	7.444	35.98	40.03	54.00	-13.97	Ave

## 802.11n20 Mode

Frequency (MHz)	S.A. Reading (dBμV)	Turntable Azimuth (degrees)	Test Antenna			Cable Loss (dB)	Pre-Amp. (dB)	Cord. Reading (dBμV/m)	FCC/IC		Comments
			Height (cm)	Polarity (H/V)	Factor (dB/m)				Limit (dBμV/m)	Margin (dB)	
Low Channel 2412 MHz											
2412	66.48	128	210	V	28.45	3.43	0.00	98.36	-	-	Peak
2412	70.39	81	214	H	29.04	3.43	0.00	102.86	-	-	Peak
2412	55.61	128	210	V	28.45	3.43	0.00	87.49	-	-	Ave
2412	59.89	81	214	H	29.04	3.43	0.00	92.36	-	-	Ave
2390	31.78	128	210	V	28.45	3.43	0.00	63.66	74.00	-10.34	Peak
2390	35.76	81	214	H	29.04	3.43	0.00	68.23	74.00	-5.77	Peak
2390	14.46	128	210	V	28.45	3.43	0.00	46.34	54.00	-7.66	Ave
2390	15.88	81	214	H	29.04	3.430	0.00	48.35	54.00	-5.65	Ave
4824	45.98	284	226	V	32.89	4.297	35.86	47.31	74.00	-26.69	Peak
4824	47.86	356	249	H	32.74	4.297	35.86	49.04	74.00	-24.96	Peak
4824	30.75	284	226	V	32.89	4.297	35.86	32.08	54.00	-21.92	Ave
4824	31.94	356	249	H	32.74	4.297	35.86	33.12	54.00	-20.88	Ave
7236	45.14	0	100	V	36.25	5.675	36.01	51.06	74.00	-22.94	Peak
7236	50.18	25	277	H	36.14	5.675	36.01	55.98	74.00	-18.02	Peak
7236	30.04	0	100	V	36.25	5.675	36.01	35.96	54.00	-18.04	Ave
7236	31.38	25	277	H	36.14	5.675	36.01	37.18	54.00	-16.82	Ave
9648	42.79	0	100	V	38.00	8.704	36.04	53.45	74.00	-20.55	Peak
9648	43.31	0	100	H	37.92	8.704	36.04	53.89	74.00	-20.11	Peak
9648	29.31	0	100	V	38.00	8.704	36.04	39.97	54.00	-14.03	Ave
9648	29.22	0	100	H	37.92	8.704	36.04	39.80	54.00	-14.20	Ave
Middle Channel 2437 MHz											
2437	65.11	133	202	V	28.348	3.430	0.00	96.89	-	-	Peak
2437	67.73	252	251	H	28.200	3.430	0.00	99.36	-	-	Peak
2437	54.32	133	202	V	28.348	3.430	0.00	86.10	-	-	Ave
2437	56.84	252	251	H	28.200	3.430	0.00	88.47	-	-	Ave
4874	45.81	160	182	V	33.295	4.404	35.90	47.61	74.00	-26.39	Peak
4874	46.9	188	219	H	32.932	4.404	35.90	48.34	74.00	-25.66	Peak
4874	31.7	160	182	V	33.295	4.404	35.90	33.50	54.00	-20.50	Ave
4874	32.96	188	219	H	32.932	4.404	35.90	34.40	54.00	-19.60	Ave
7311	45.1	0	100	V	36.694	5.788	35.96	51.62	74.00	-22.38	Peak
7311	46.65	0	100	H	36.575	5.788	35.96	53.06	74.00	-20.94	Peak
7311	30.42	0	100	V	36.694	5.788	35.96	36.94	54.00	-17.06	Ave
7311	30.56	0	100	H	36.575	5.788	35.96	36.97	54.00	-17.03	Ave
9748	44.33	0	100	V	38.128	8.157	36.03	54.58	74.00	-19.42	Peak
9748	44.75	0	100	H	37.896	8.157	36.03	54.77	74.00	-19.23	Peak
9748	30.05	0	100	V	38.128	8.157	36.03	40.30	54.00	-13.70	Ave
9748	30.2	0	100	H	37.896	8.157	36.03	40.22	54.00	-13.78	Ave

Frequency (MHz)	S.A. Reading (dB $\mu$ V)	Turntable Azimuth (degrees)	Test Antenna			Cable Loss (dB)	Pre-Amp. (dB)	Cord. Reading (dB $\mu$ V/m)	FCC/IC		Comments
			Height (cm)	Polarity (H/V)	Factor (dB/m)				Limit (dB $\mu$ V/m)	Margin (dB)	
High Channel 2462 MHz											
2462	64.21	174	288	V	28.61	3.43	0.00	96.25	-	-	Peak
2462	69.56	216	220	H	28.52	3.43	0.00	101.51	-	-	Peak
2462	53.44	174	288	V	28.61	3.43	0.00	85.48	-	-	Ave
2462	58.82	216	220	H	28.52	3.43	0.00	90.77	-	-	Ave
2483.5	28.78	174	288	V	28.61	3.43	0.00	60.82	74.00	-13.18	Peak
2483.5	31.47	216	220	H	28.52	3.43	0.00	63.42	74.00	-10.59	Peak
2483.5	13.37	174	288	V	28.61	3.43	0.00	45.41	54.00	-8.59	Ave
2483.5	14.7	216	220	H	28.52	3.43	0.00	46.65	54.00	-7.36	Ave
4924	45.06	0	100	V	33.32	4.485	35.91	46.95	74.00	-27.05	Peak
4924	45.2	0	100	H	33.24	4.485	35.91	47.02	74.00	-26.98	Peak
4924	30.99	0	100	V	33.32	4.485	35.91	32.88	54.00	-21.12	Ave
4924	31.08	0	100	H	33.24	4.485	35.91	32.90	54.00	-21.10	Ave
7386	44.84	0	100	V	36.88	5.869	35.96	51.63	74.00	-22.37	Peak
7386	44.67	0	100	H	36.76	5.869	35.96	51.33	74.00	-22.67	Peak
7386	30.11	0	100	V	36.88	5.869	35.96	36.90	54.00	-17.10	Ave
7386	30.16	0	100	H	36.76	5.869	35.96	36.82	54.00	-17.18	Ave
9848	42.75	0	100	V	38.36	7.444	35.98	52.58	74.00	-21.42	Peak
9848	43.53	0	100	H	38.37	7.444	35.98	53.37	74.00	-20.63	Peak
9848	29.65	0	100	V	38.36	7.444	35.98	39.48	54.00	-14.52	Ave
9848	29.68	0	100	H	38.37	7.444	35.98	39.52	54.00	-14.48	Ave

## 8 FCC §15.247(a)(2) & IC RSS-247 §5.2 - 6 dB & 99% Emission Bandwidth

### 8.1 Applicable Standards

According to FCC §15.247(a)(2), systems using digital modulation techniques may operate in the 902-928 MHz, 2400-2483.5 MHz, and 5725~5850 MHz bands. The minimum 6 dB bandwidth shall be at least 500 kHz

According to IC RSS-247 5.2 (1), DTSs include systems that employ digital modulation techniques resulting in spectral characteristics similar to direct sequence systems. The minimum 6 dB bandwidth shall be 500 kHz for bands 902 -928 MHz and 2400-2483.5 MHz.

### 8.2 Measurement Procedure

The measurements are based on FCC KDB 558074 D01 DTS Meas Guidance v03r03: Guidance for Performing Compliance Measurements on Digital Transmission Systems (DTS) Operating Under §15.247 section 8: DTS bandwidth

### 8.3 Test Equipment List and Details

Manufacturer	Description	Model No.	Serial No.	Calibration Date	Calibration Interval
Agilent	Spectrum Analyzer	E4440A	US42221851	2015-06-23	1 year
-	SMA Cable	-	C0001	Each Time <sup>1</sup>	N/A
Mini-Circuits	Attenuator	BW-S20W5	1430	Each Time <sup>1</sup>	N/A

Note<sup>1</sup>: cable and attenuator included in the test set-up will be checked each time before testing.

*Statement of Traceability: BACL Corp. attests that all calibrations have been performed per the A2LA requirements, traceable to the NIST.*

### 8.4 Test Environmental Conditions

Temperature:	22 °C
Relative Humidity:	42 %
ATM Pressure:	102.7 kPa

*The testing was performed by Leonard Gray on 2015-12-21 in RF site.*

**8.5 Test Results**

Channel	Frequency (MHz)	99 % OBW (MHz)	6 dB OBW (MHz)	6 dB OBW Limit (kHz)	Result
802.11b					
Low	2412	13.3097	10.074	≥ 500	Pass
Middle	2437	13.3124	10.059	≥ 500	Pass
High	2462	13.3765	10.056	≥ 500	Pass
802.11g					
Low	2412	16.4412	16.597	≥ 500	Pass
Middle	2437	16.4498	16.579	≥ 500	Pass
High	2462	16.5847	16.567	≥ 500	Pass
802.11n20					
Low	2412	17.6854	17.866	≥ 500	Pass
Middle	2437	17.6847	17.862	≥ 500	Pass
High	2462	17.7709	17.859	≥ 500	Pass

*Please refer to the following plots for detailed test results*



802.11b - 2412 MHz

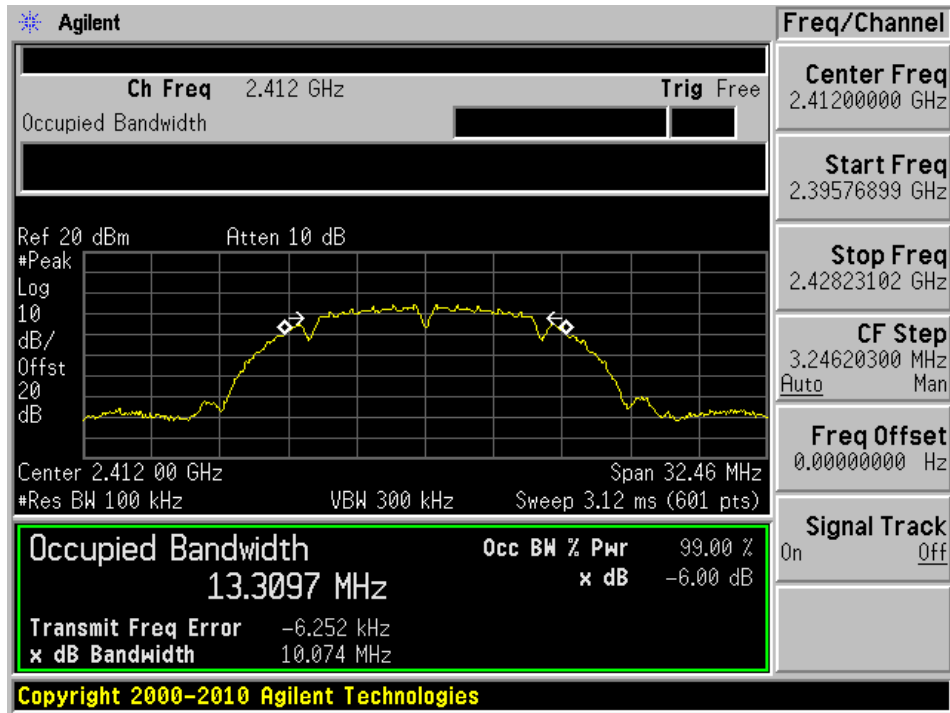

802.11b - 2437 MHz

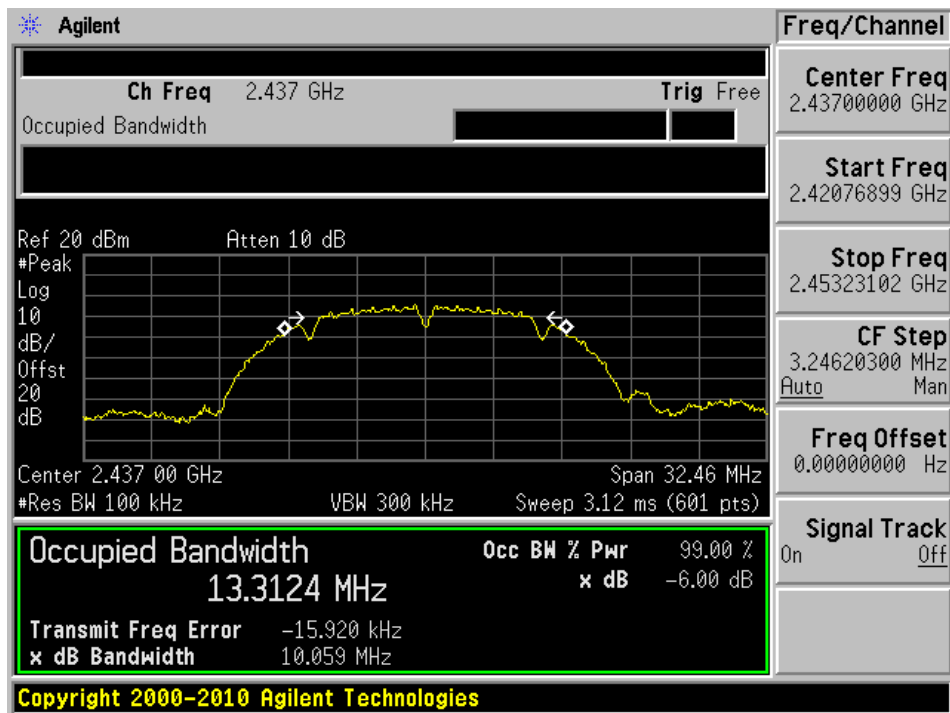

802.11b - 2462 MHz

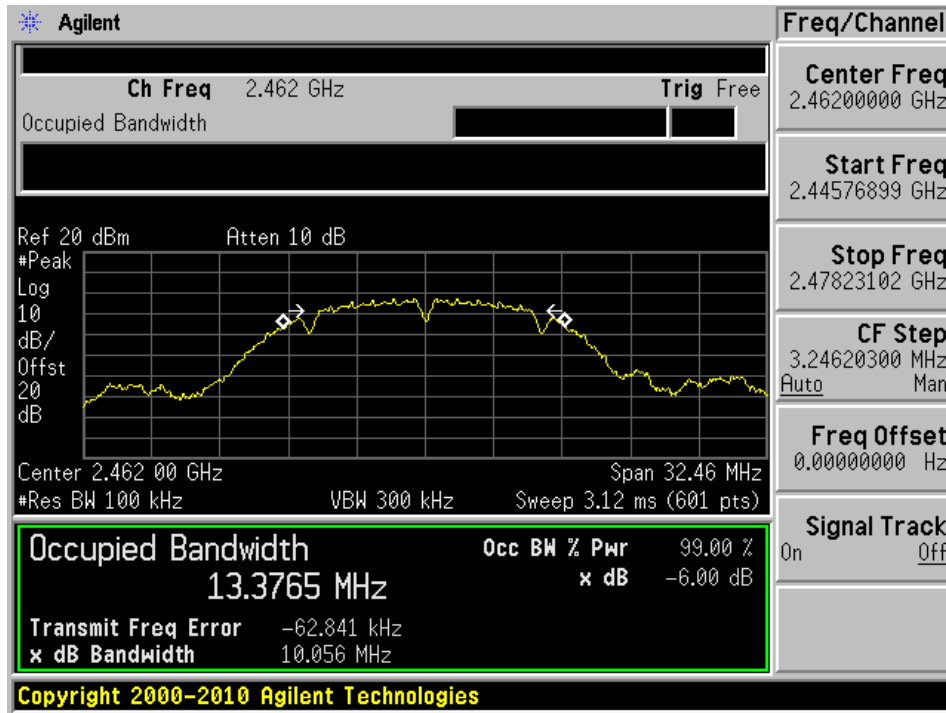

802.11g - 2412 MHz

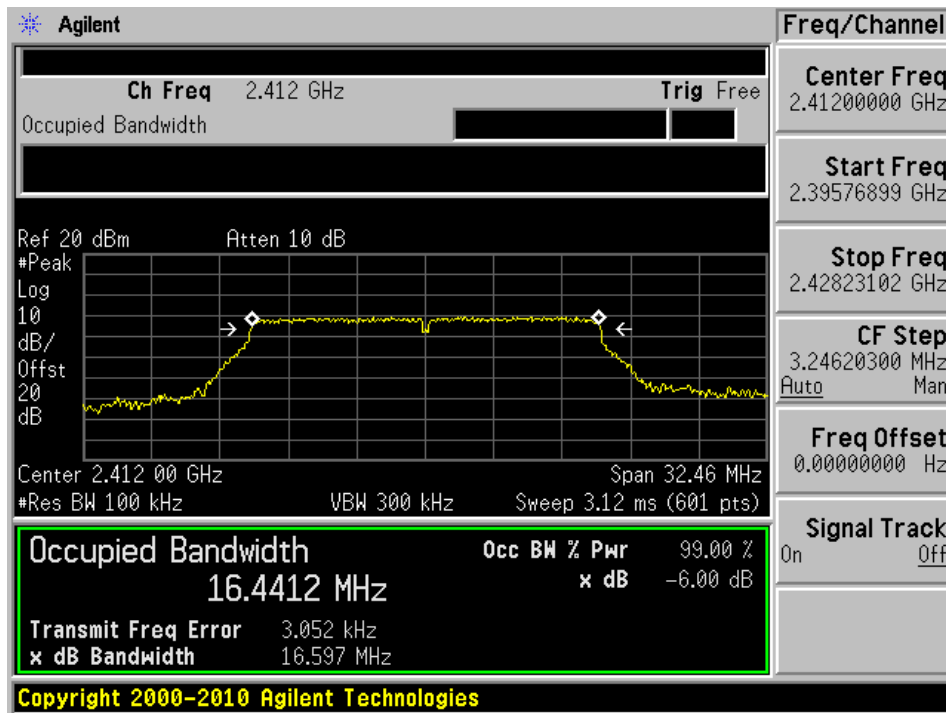

802.11g - 2437 MHz

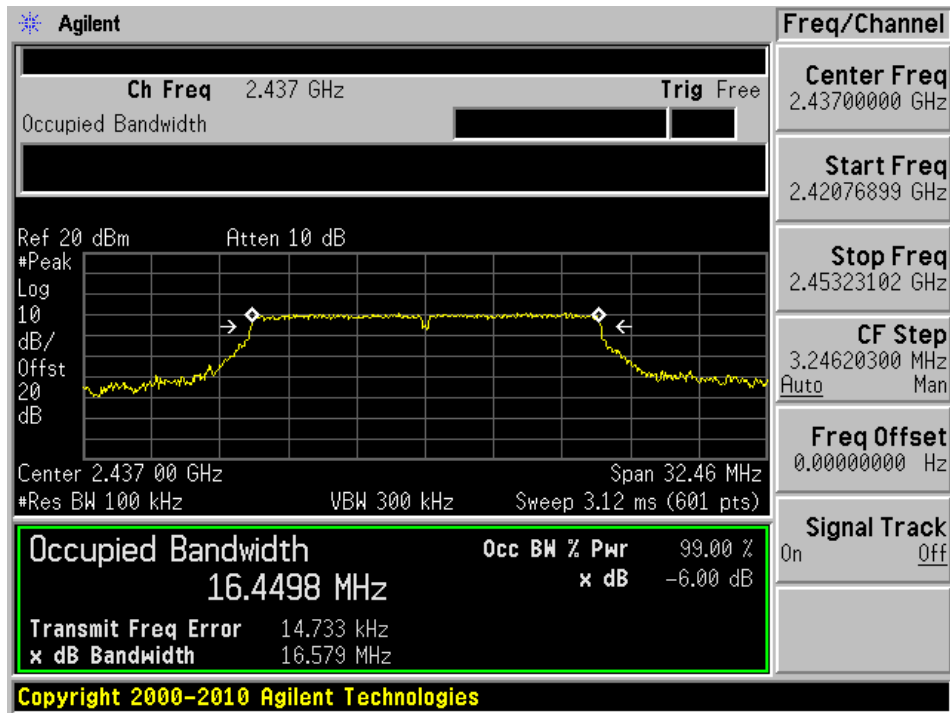

802.11g - 2462 MHz

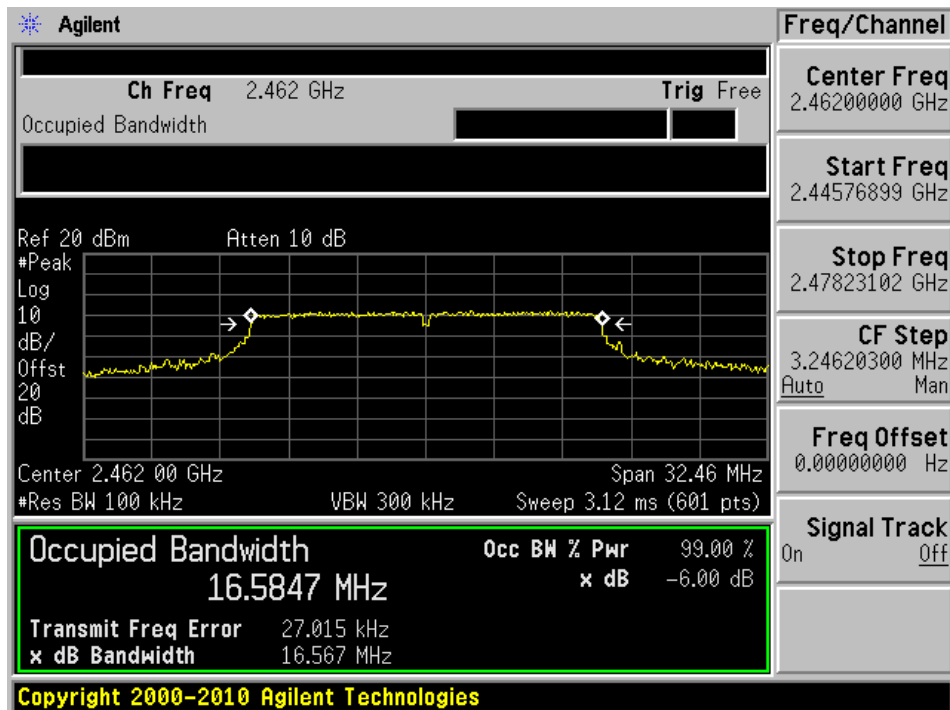

802.11n20 - 2412 MHz

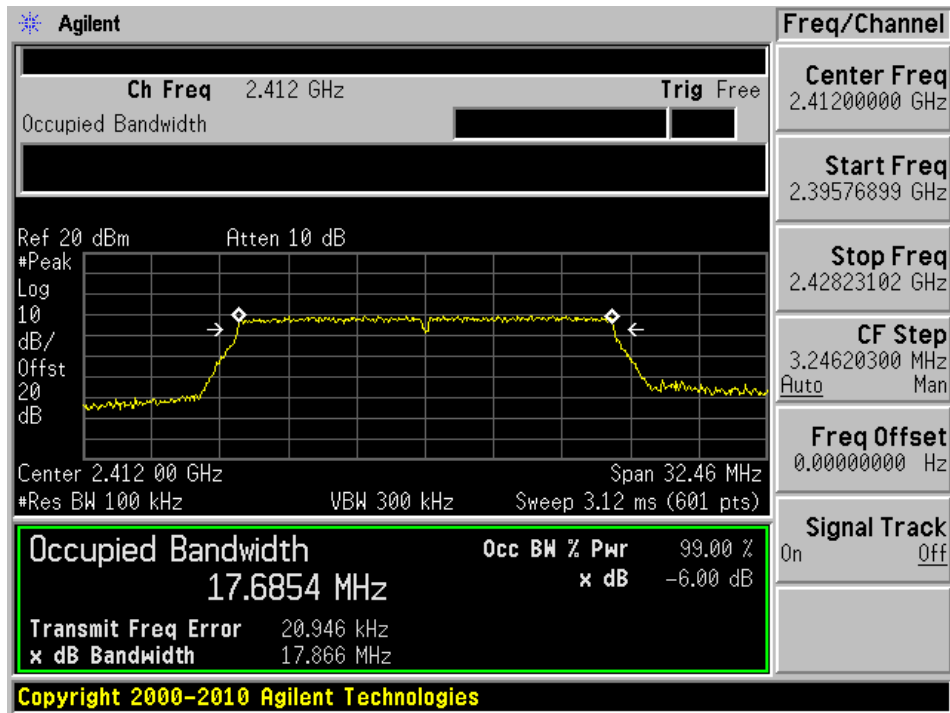

802.11n20 - 2437 MHz

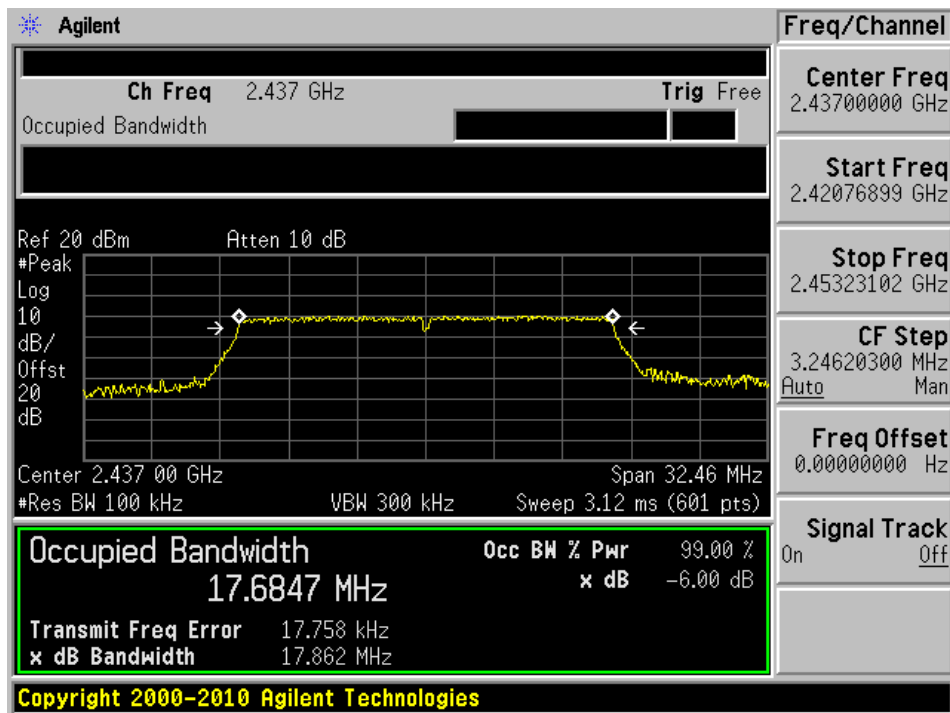

802.11n20 - 2462 MHz

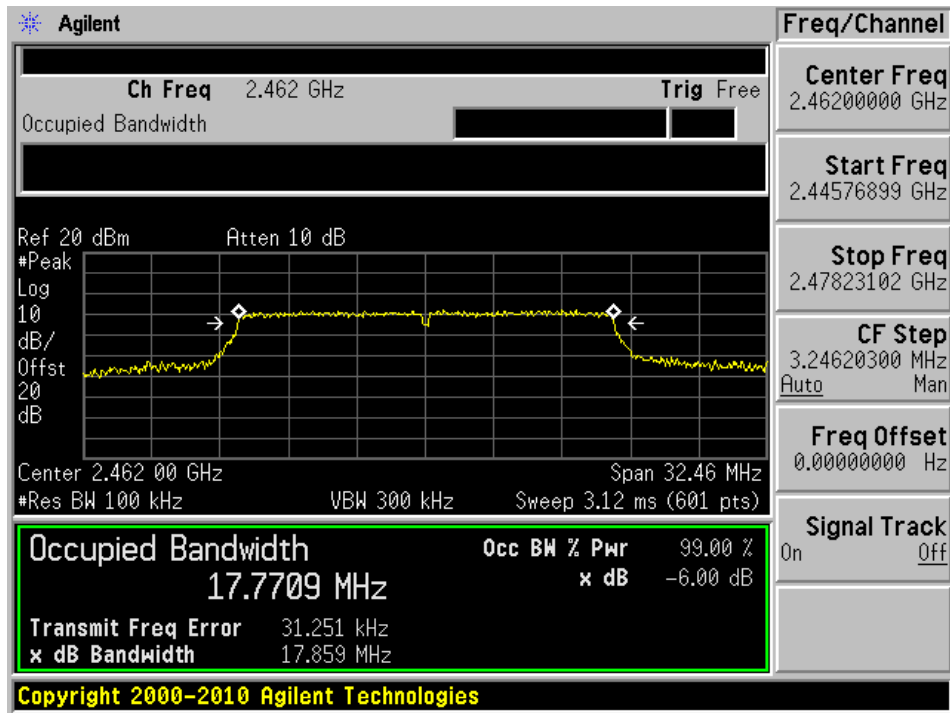

## 9 FCC §15.247(b) & IC RSS-247 §5.4 - Output Power Measurement

### 9.1 Applicable Standards

According to FCC §15.247(b) for systems using digital modulation in the 902~928 MHz, 2400~2483.5 MHz, and 5725~5850 MHz bands: 1 Watt.

According to IC RSS-247 §5.4 (4), for DTSs employing digital modulation techniques operating in the bands 902-928 MHz and 2400-2483.5 MHz, the maximum peak conducted output power shall not exceed 1W. Except as provided in Section 5.4(5), the e.i.r.p. shall not exceed 4 W.

### 9.2 Measurement Procedure

The measurements are based on FCC KDB 558074 D01 DTS Meas Guidance v03r03: Guidance for Performing Compliance Measurements on Digital Transmission Systems (DTS) Operating Under §15.247 section 9: Fundamental emission output power

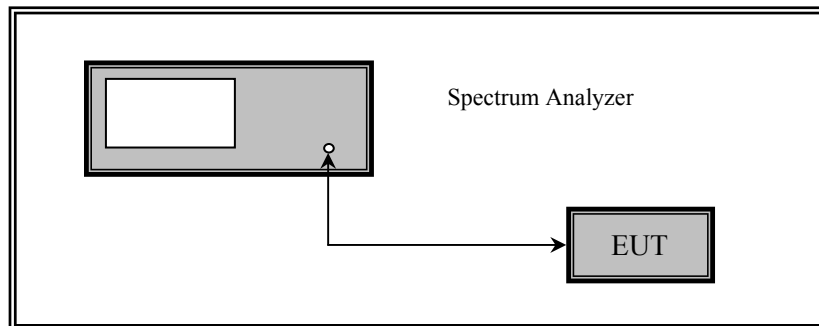

### 9.3 Test Equipment List and Details

Manufacturer	Description	Model No.	Serial No.	Calibration Date	Calibration Interval
Agilent	Spectrum Analyzer	E4440A	US42221851	2015-06-23	1 year
-	SMA Cable	-	C0001	Each Time <sup>1</sup>	N/A
Mini-Circuits	Attenuator	BW-S20W5	1430	Each Time <sup>1</sup>	N/A

<sup>1</sup> cable and attenuator included in the test set-up will be checked each time before testing.

**Statement of Traceability:** *BACL Corp.* attests that all calibrations have been performed per the A2LA requirements, traceable to the NIST.

## 9.4 Test Environmental Conditions

<b>Temperature:</b>	21-24 °C
<b>Relative Humidity:</b>	40-44 %
<b>ATM Pressure:</b>	102.1-103.5 kPa

*The testing was performed by Leonard Gray on 2015-12-17 in RF site.*

## 9.5 Test Results

Channel	Frequency (MHz)	Conducted Output Power (dBm)	Limit (dBm)	Result
802.11b				
Low	2412	4.41	30	Pass
Middle	2437	5.43	30	Pass
High	2462	6.58	30	Pass
802.11g				
Low	2412	3.24	30	Pass
Middle	2437	4.35	30	Pass
High	2462	5.5	30	Pass
802.11n20				
Low	2412	3.17	30	Pass
Middle	2437	4.47	30	Pass
High	2462	5.44	30	Pass

*Please refer to the following plots for detailed test results*

802.11b 2412 MHz

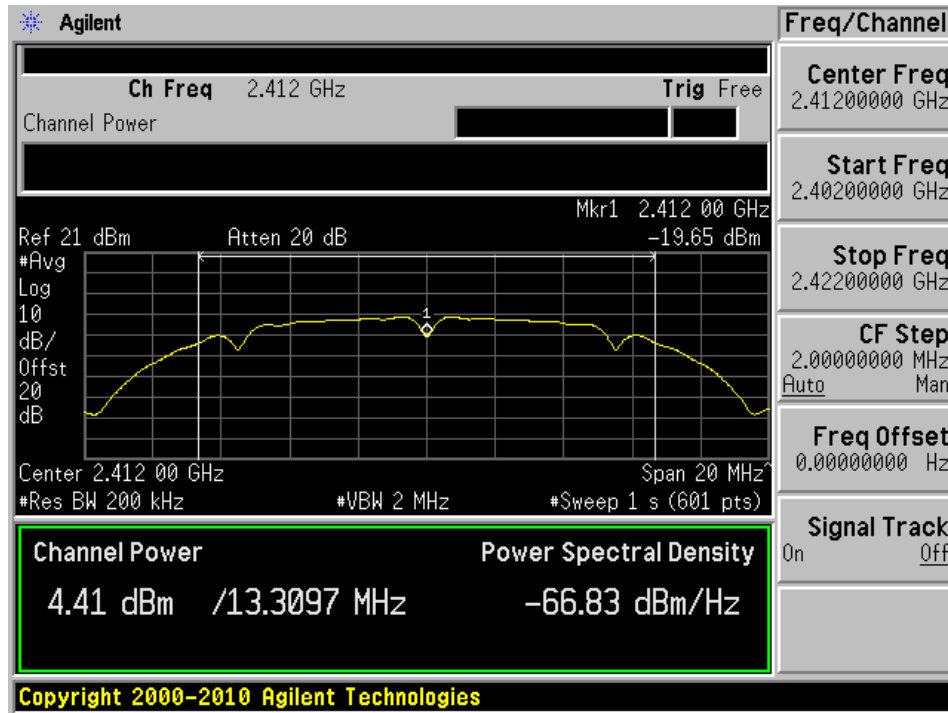

802.11b 2437 MHz

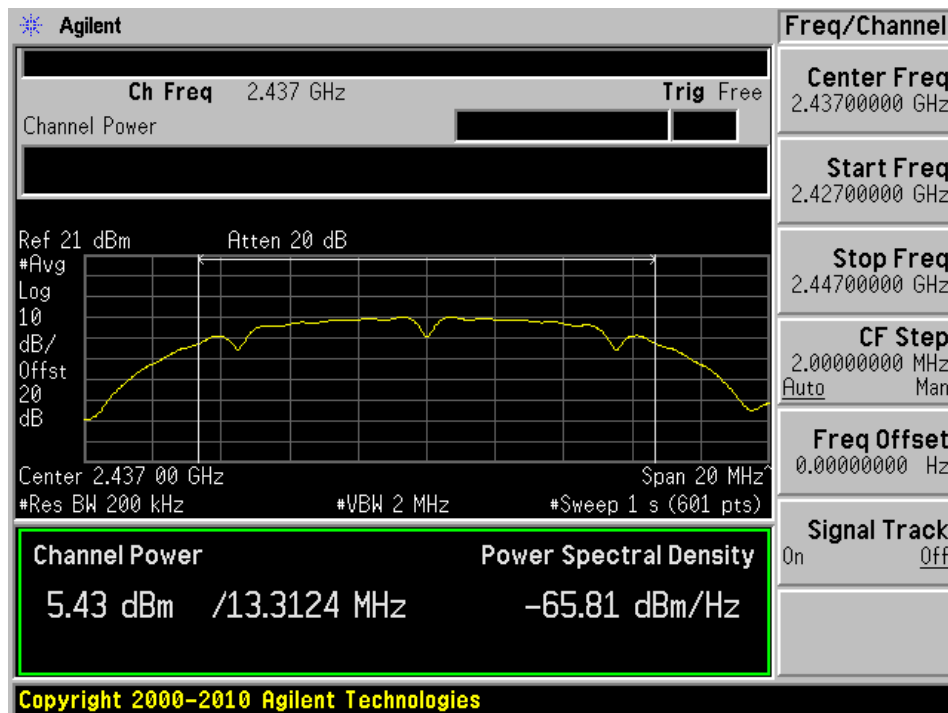



802.11b 2462 MHz

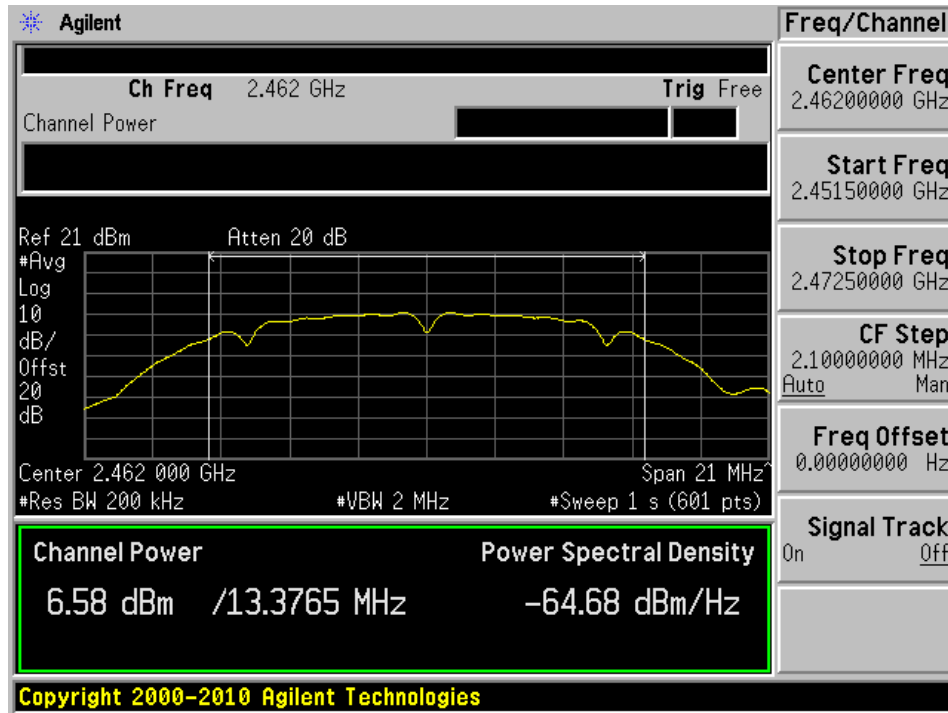

802.11g 2412 MHz

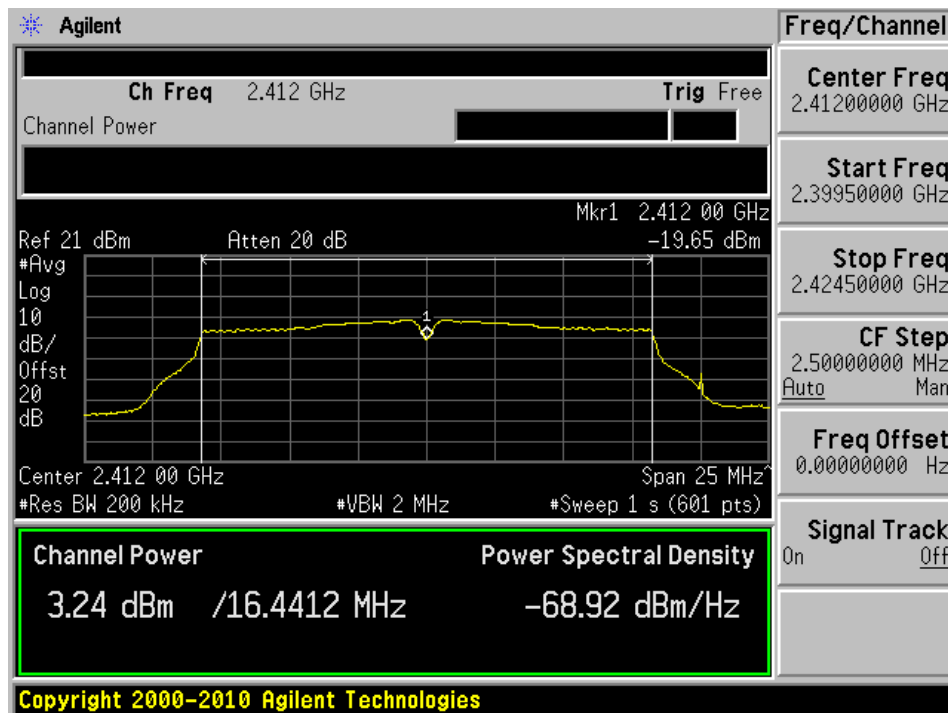

802.11g 2437 MHz

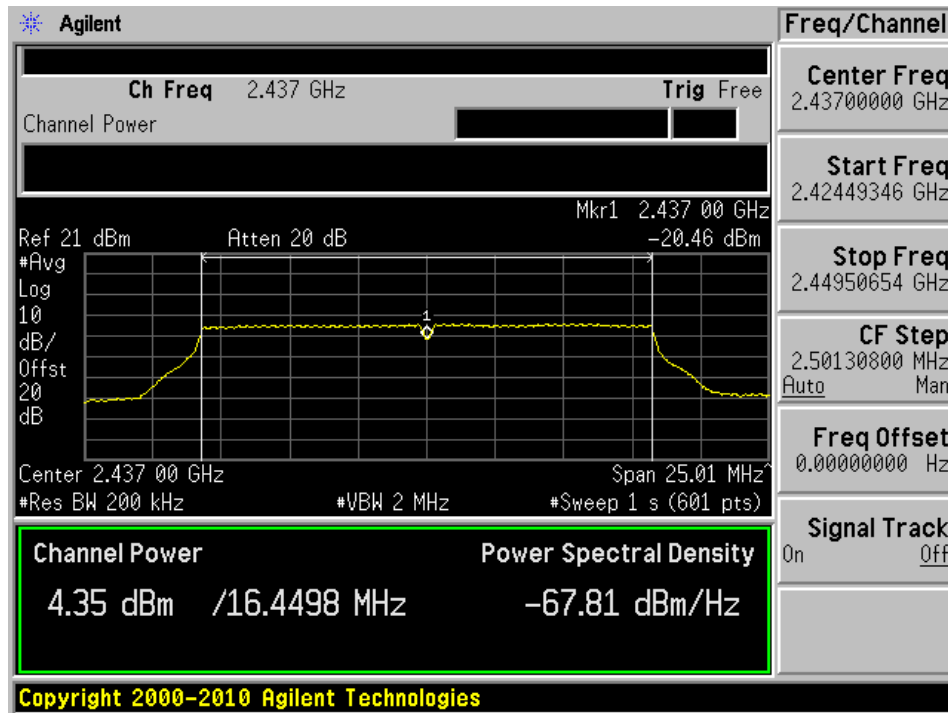

802.11g 2462 MHz

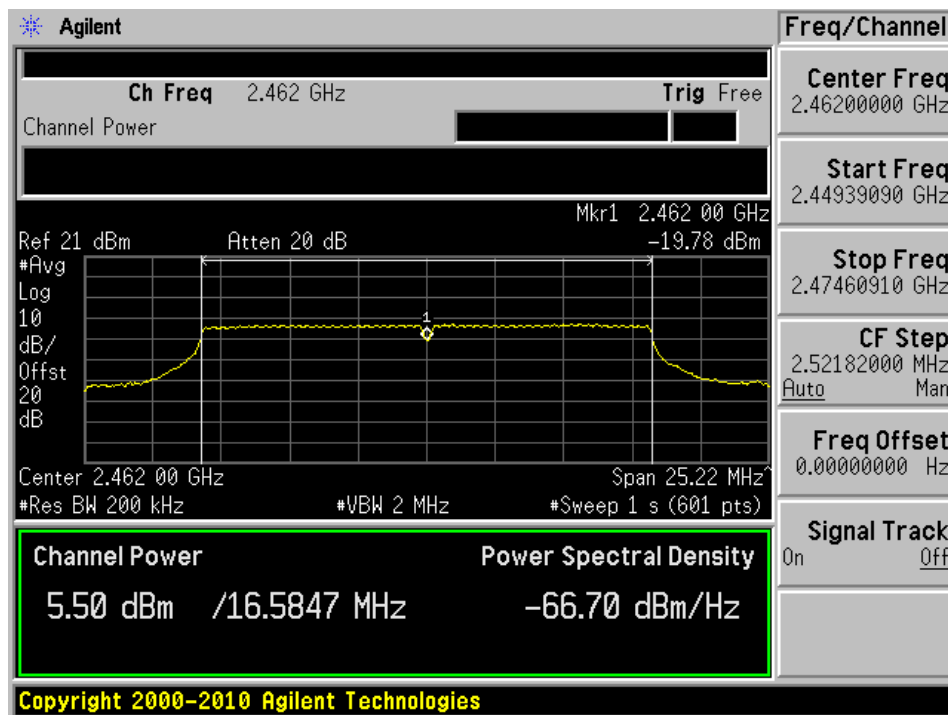

802.11n20 2412 MHz

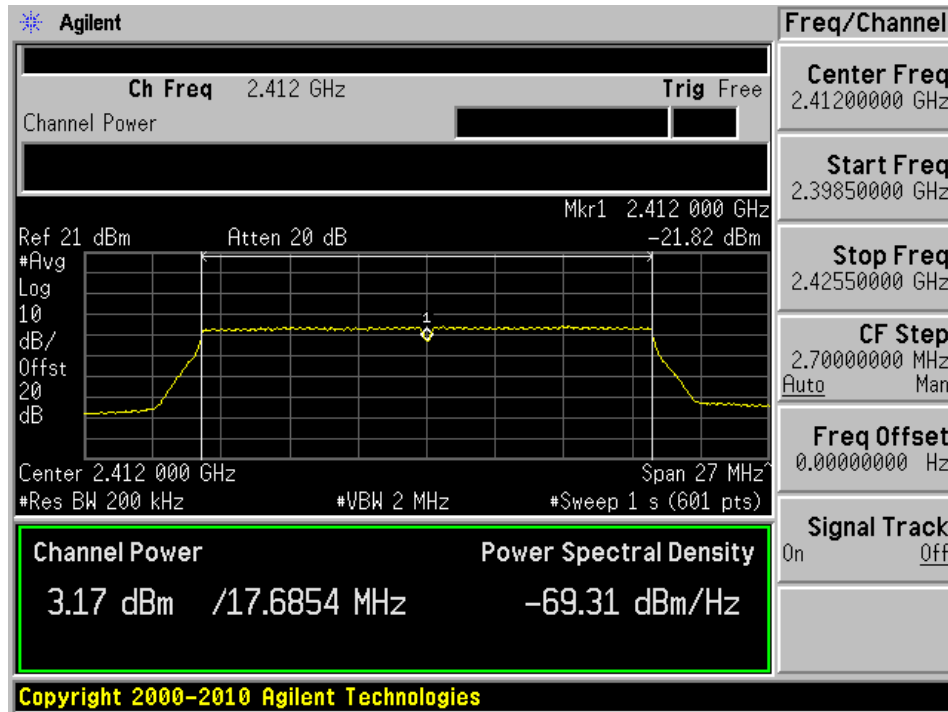

802.11n20 2437 MHz

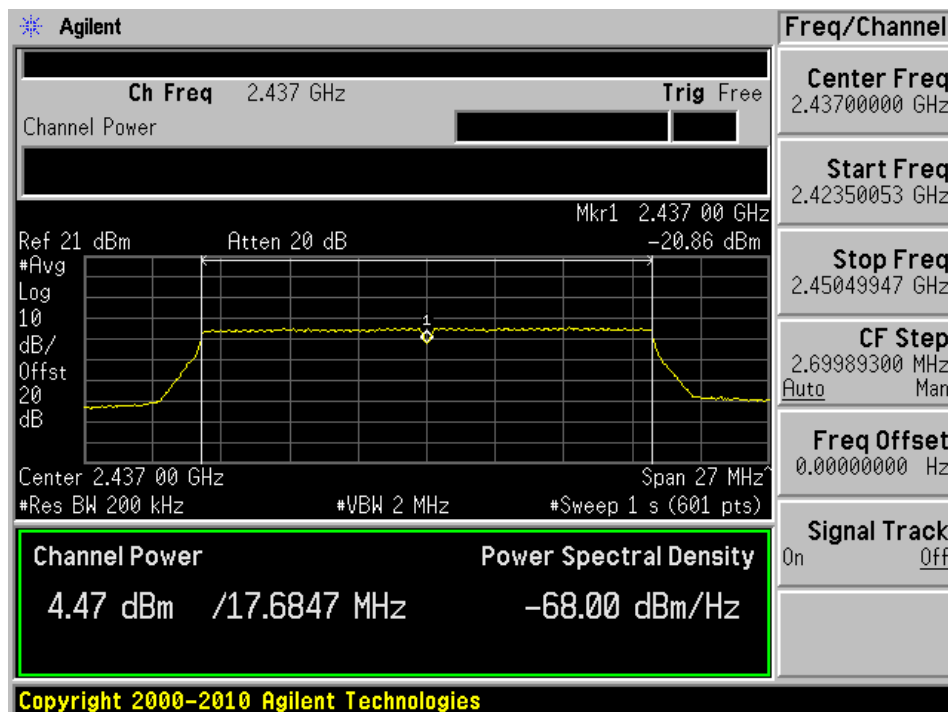

802.11n20 2462 MHz

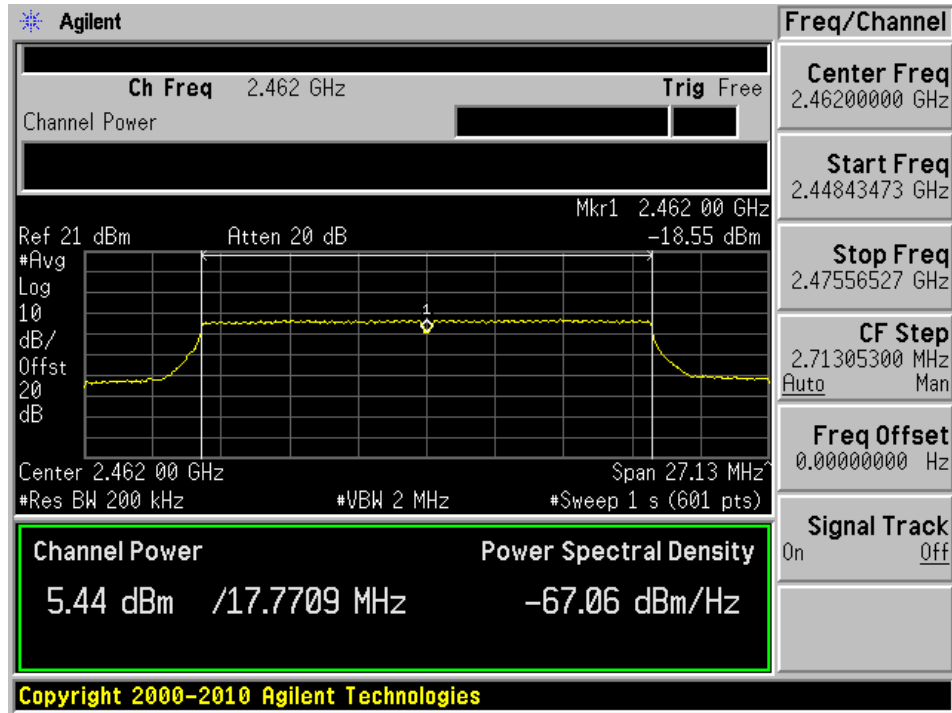

## 10 FCC §15.247(d) & IC RSS-247 §5.5 - Spurious Emissions at Antenna Port and Band Edges

### 10.1 Applicable Standards

According to FCC §15.247(d), in any 100 kHz bandwidth outside the frequency bands in which the spread spectrum intentional radiator is operating, the radio frequency power that is produced by the intentional radiator shall be at least 20 dB below that in the 100 kHz bandwidth within the band that contains the highest level of the desired power, based on either an RF conducted or a radiated measurement. In addition, radiated emissions which fall in the restricted bands, as defined in §15.205(a), must also comply with the radiated emissions limits specified in §15.209(a) see §15.205(c).

For IC RSS-247 §5.5, in any 100 kHz bandwidth outside the frequency band in which the spread spectrum or digitally modulated device is operating, the RF power that is produced shall be at least 20 dB below that in the 100 kHz bandwidth within the band that contains the highest level of the desired power, based on either an RF conducted or a radiated measurement, provided that the transmitter demonstrates compliance with the peak conducted power limits. If the transmitter complies with the conducted power limits based on the use of root-mean-square averaging over a time interval, as permitted under Section 5.4(4), the attenuation required shall be 30 dB instead of 20 dB. Attenuation below the general field strength limits specified in RSS-Gen is not required.

### 10.2 Measurement Procedure

The measurements are based on FCC KDB 558074 D01 DTS Meas Guidance v03r03: Guidance for Performing Compliance Measurements on Digital Transmission Systems (DTS) Operating Under §15.247 section 13: Band-edge measurements

### 10.3 Test Equipment List and Details

Manufacturer	Description	Model No.	Serial No.	Calibration Date	Calibration Interval
Rohde & Schwarz	Spectrum Analyzer	FSQ	1155.5001.26	2015-03-09	1 year
Agilent	Spectrum Analyzer	E4440A	US42221851	2015-06-23	1 year
-	SMA Cable	-	C0001	Each Time <sup>1</sup>	N/A
Mini-Circuits	Attenuator	BW-S20W5	1430	Each Time <sup>1</sup>	N/A

Note<sup>1</sup>: cable and attenuator included in the test set-up will be checked each time before testing.

**Statement of Traceability:** *BACL Corp. attests that all calibrations have been performed per the A2LA requirements, traceable to the NIST.*

## 10.4 Test Environmental Conditions

<b>Temperature:</b>	22 °C
<b>Relative Humidity:</b>	42 %
<b>ATM Pressure:</b>	102.7 kPa

*The testing was performed by Leonard Gray on 2015-12-22 in RF site.*

## 10.5 Test Results

Please refer to the following plots.

### Spurious Emissions at Antenna Port

802.11b-2412 MHz (30 MHz-3 GHz)

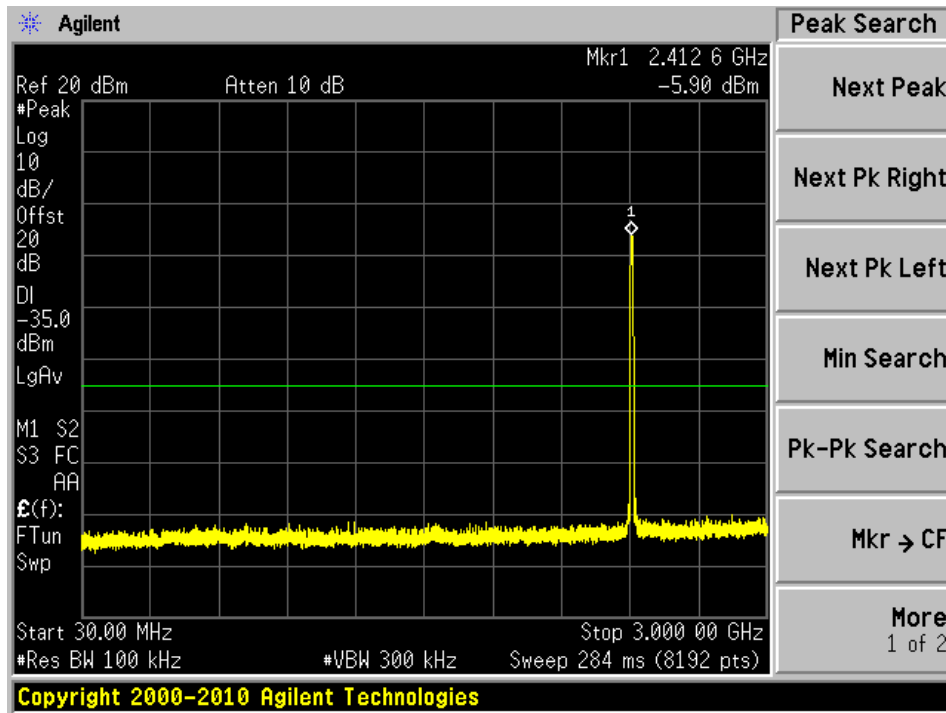

802.11b-2412 MHz (3-26 GHz)

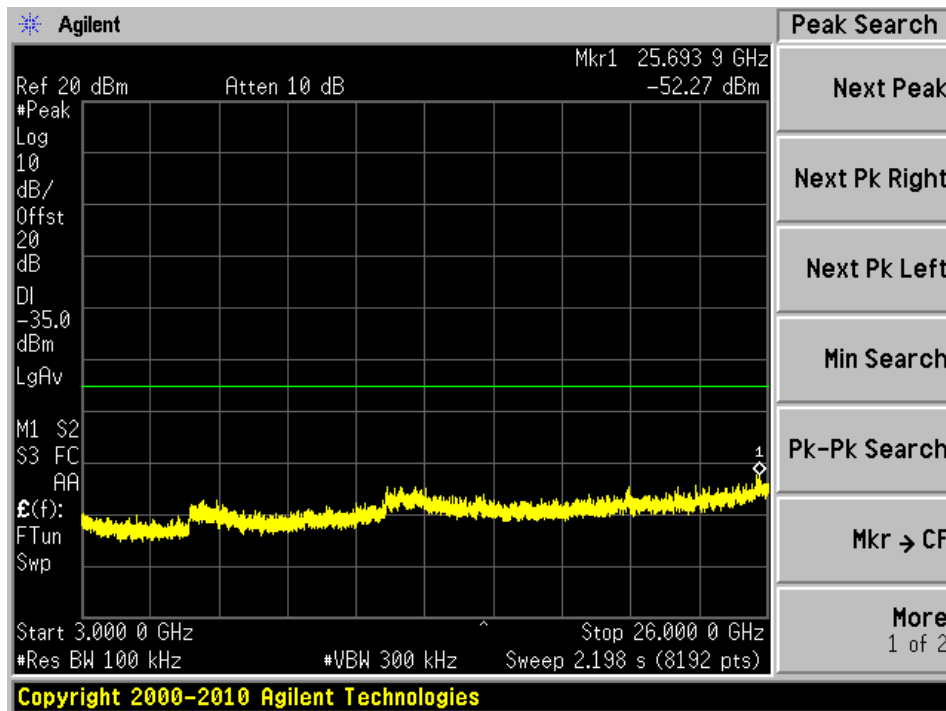

802.11b-2437 MHz (30 MHz-3 GHz)

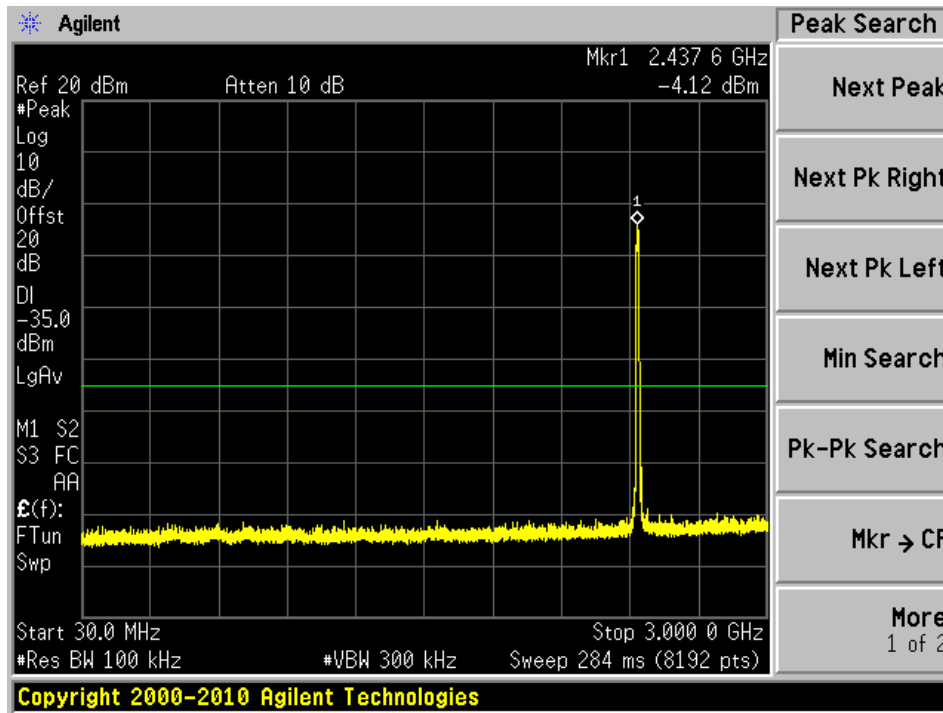

802.11b-2437 MHz (3-26 GHz)

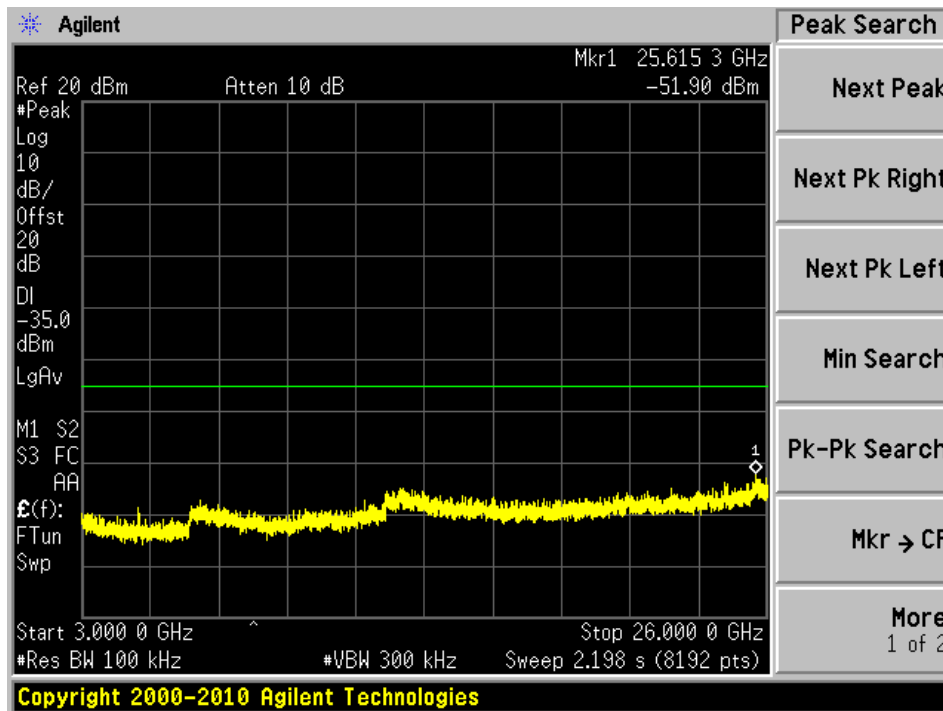



802.11b-2462 MHz (30 MHz-3 GHz)

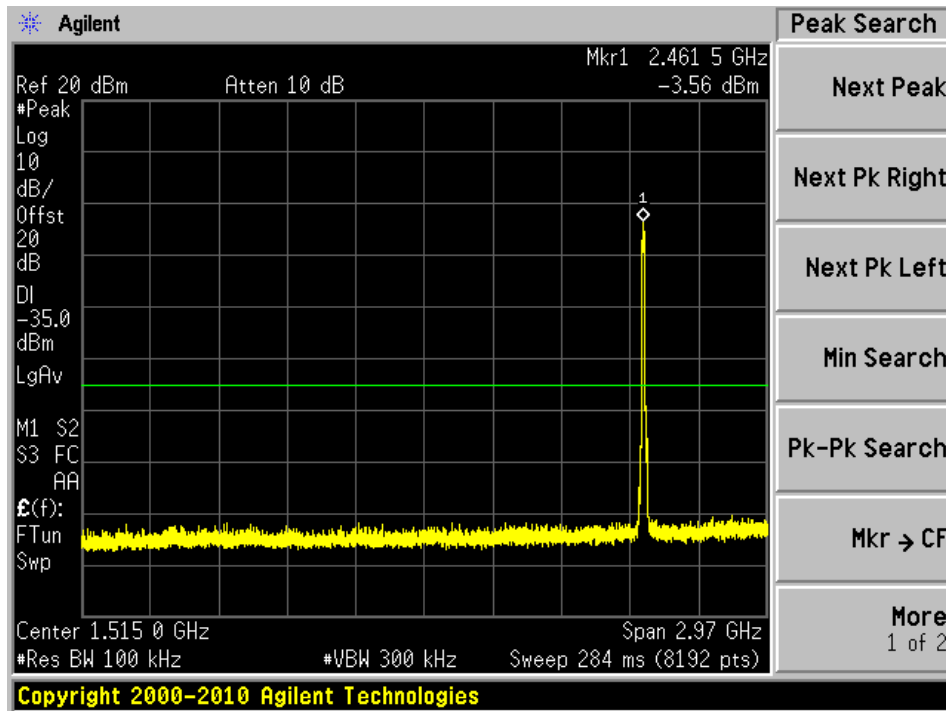

802.11b-2462 MHz (3-26 GHz)

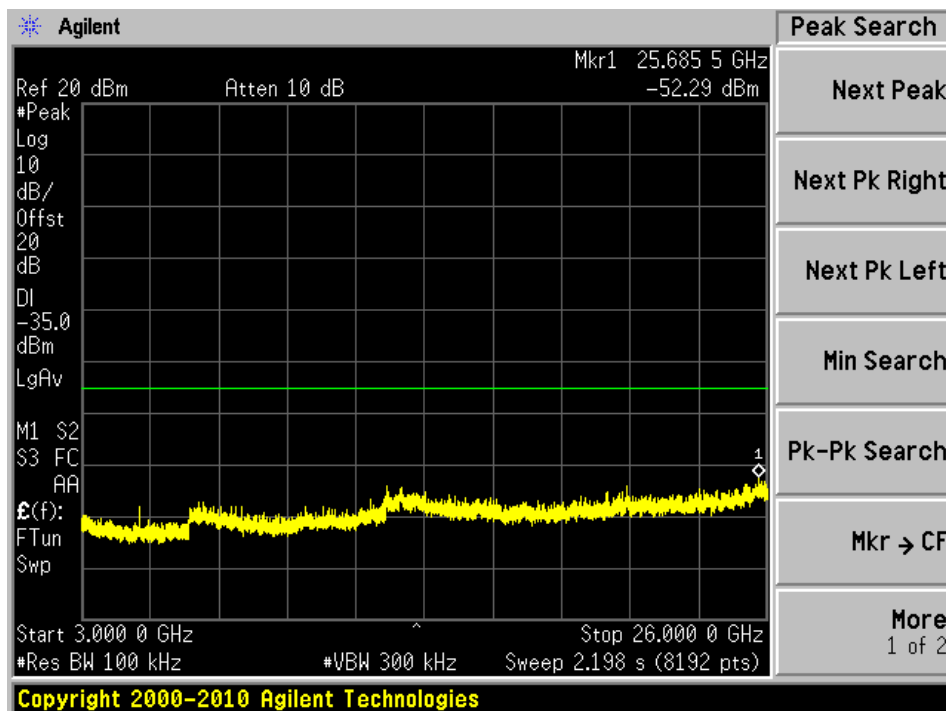

802.11g-2412 MHz (30 MHz-3 GHz)

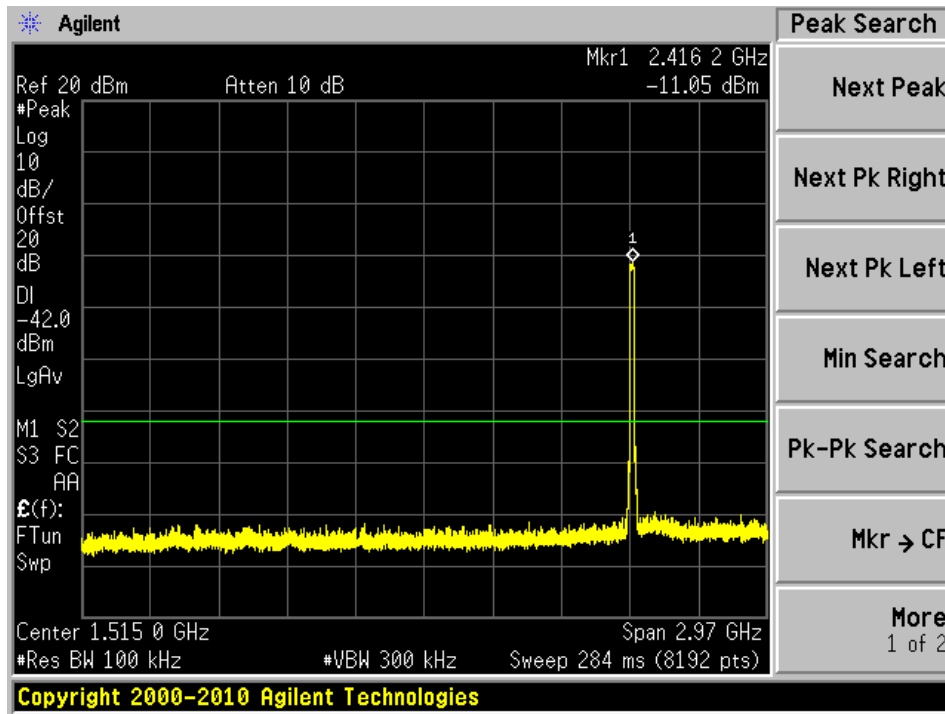

802.11g-2412 MHz (3-26 GHz)

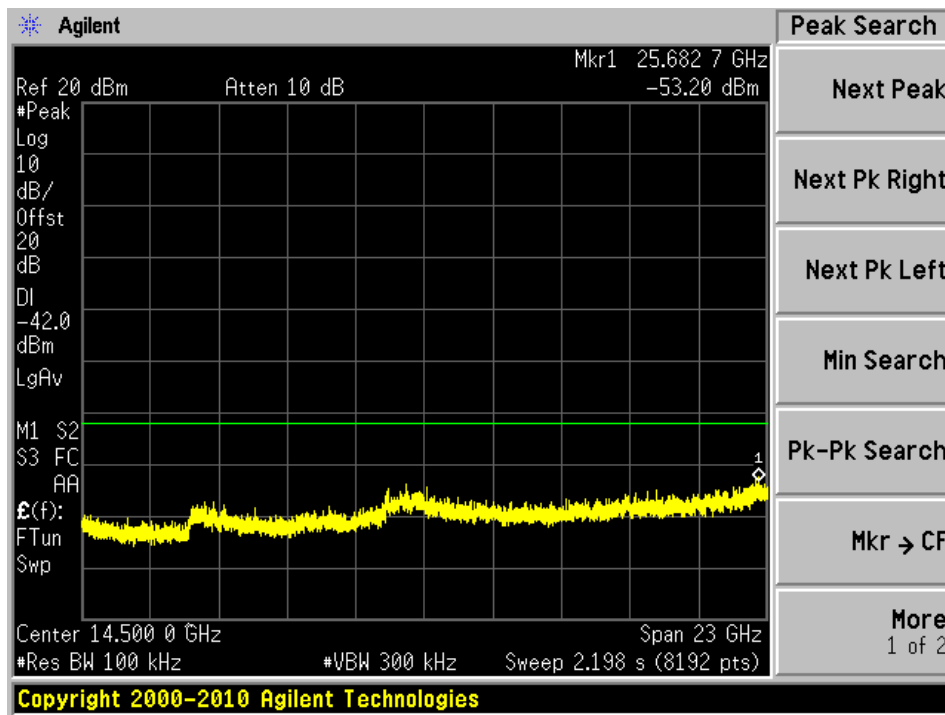

802.11g-2437 MHz (30 MHz-3 GHz)

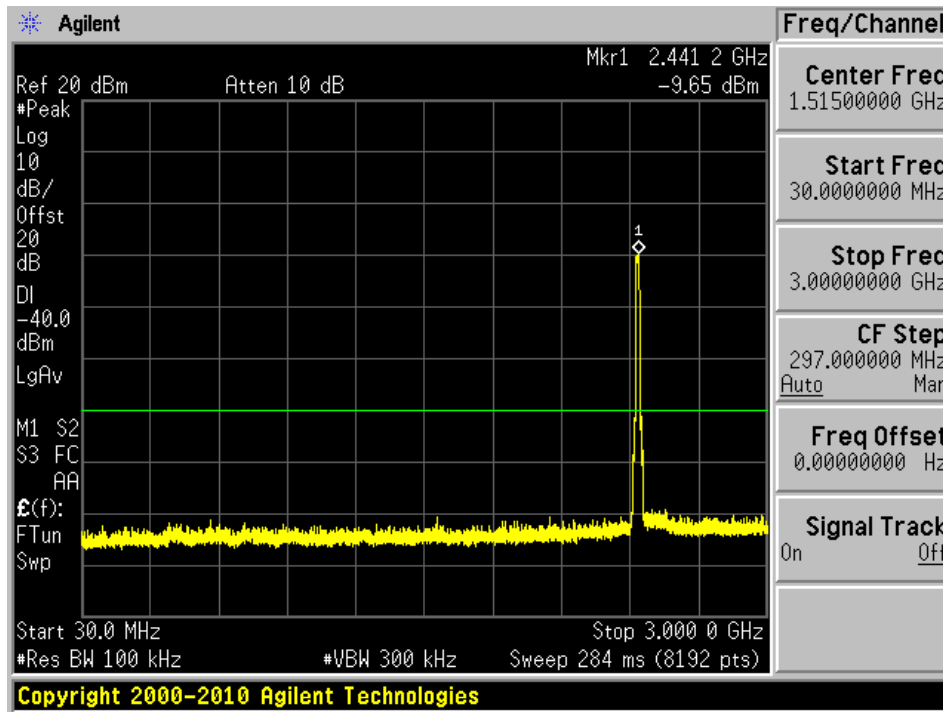

802.11g-2437 MHz (3-26 GHz)

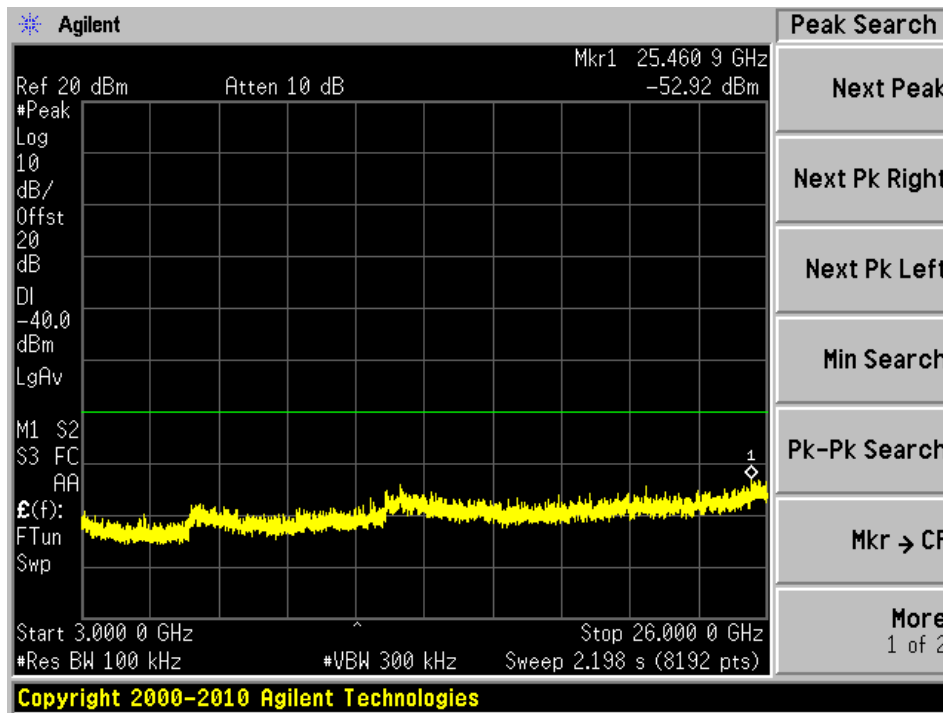

802.11g-2462 MHz (30 MHz-3 GHz)

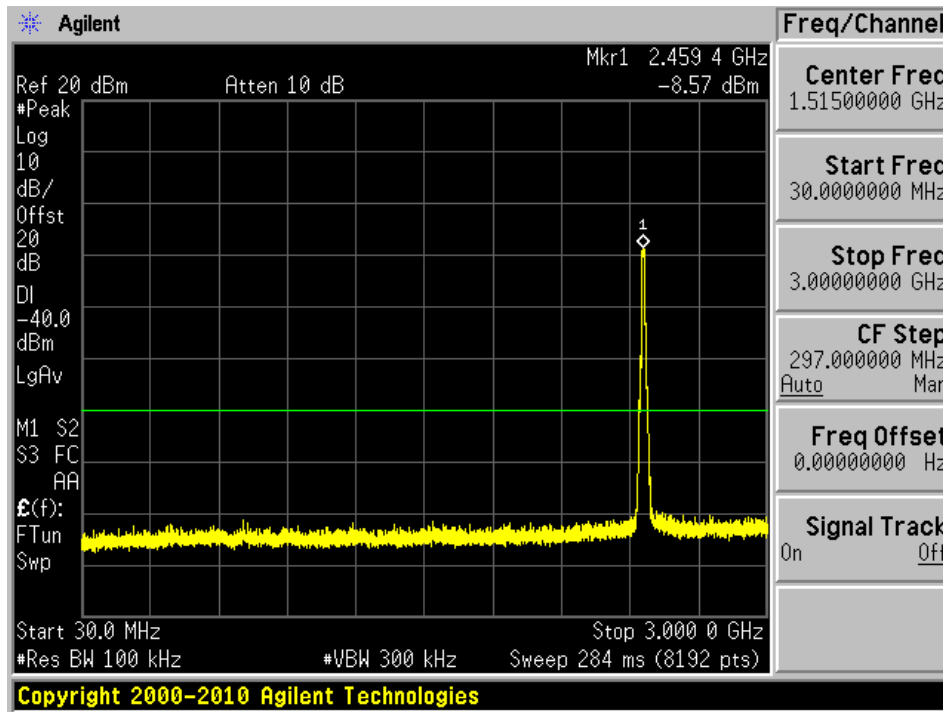

802.11g-2462 MHz (3-26 GHz)

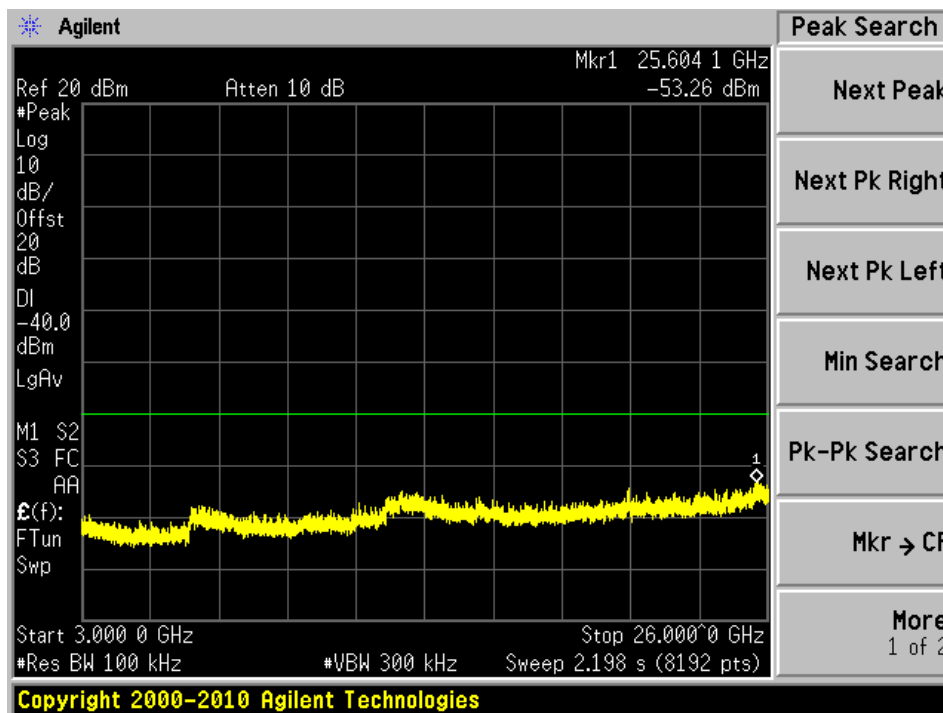

802.11n20-2412 MHz (30 MHz-3 GHz)

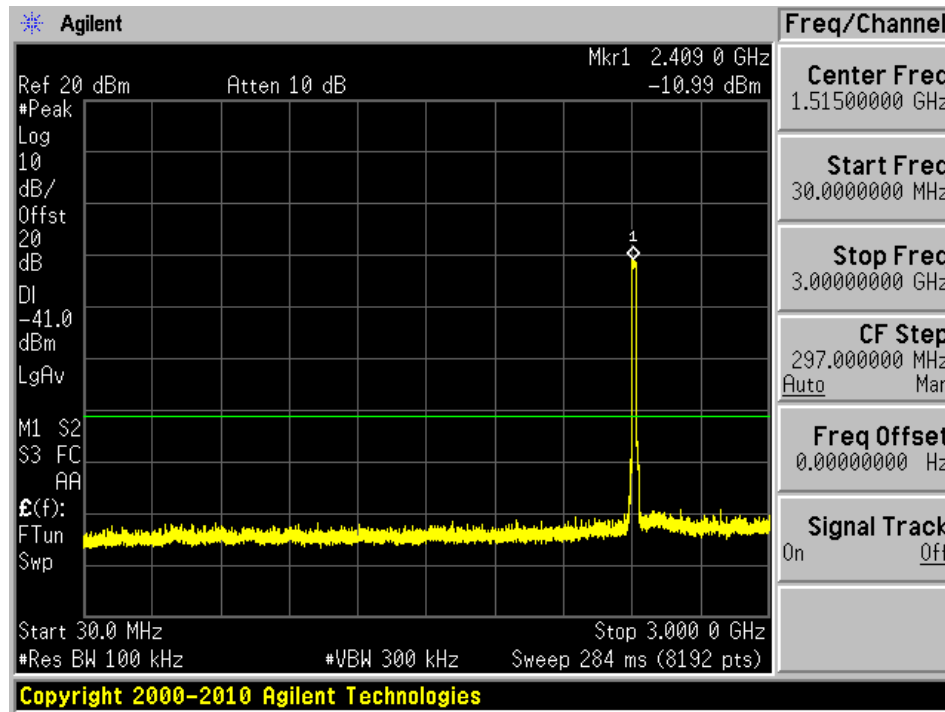

802.11n20-2412 MHz (3-26 GHz)

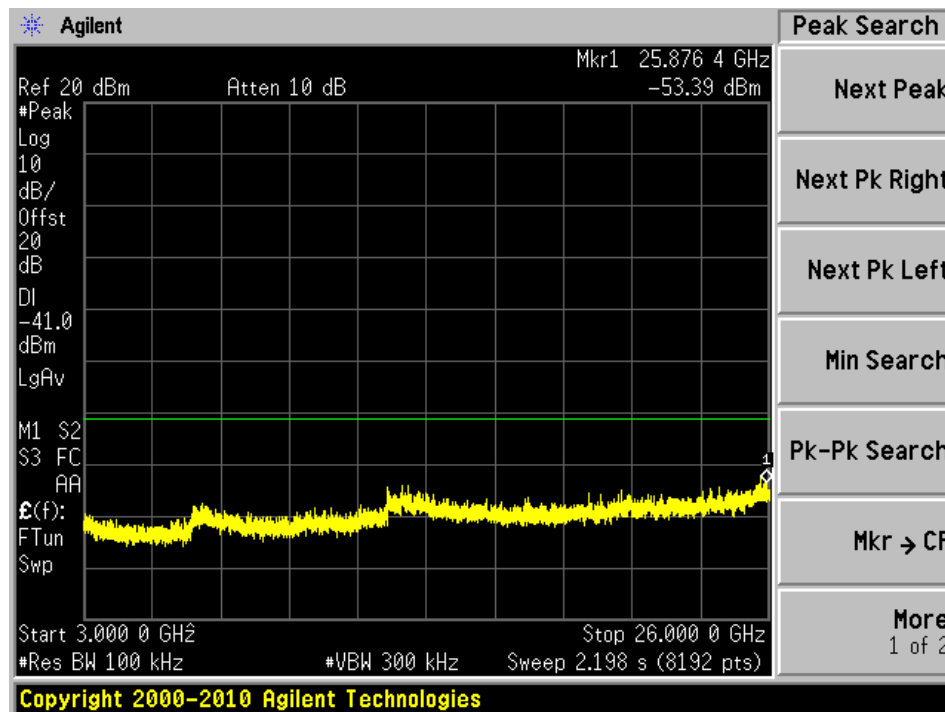

802.11n20-2437 MHz (30 MHz-3 GHz)

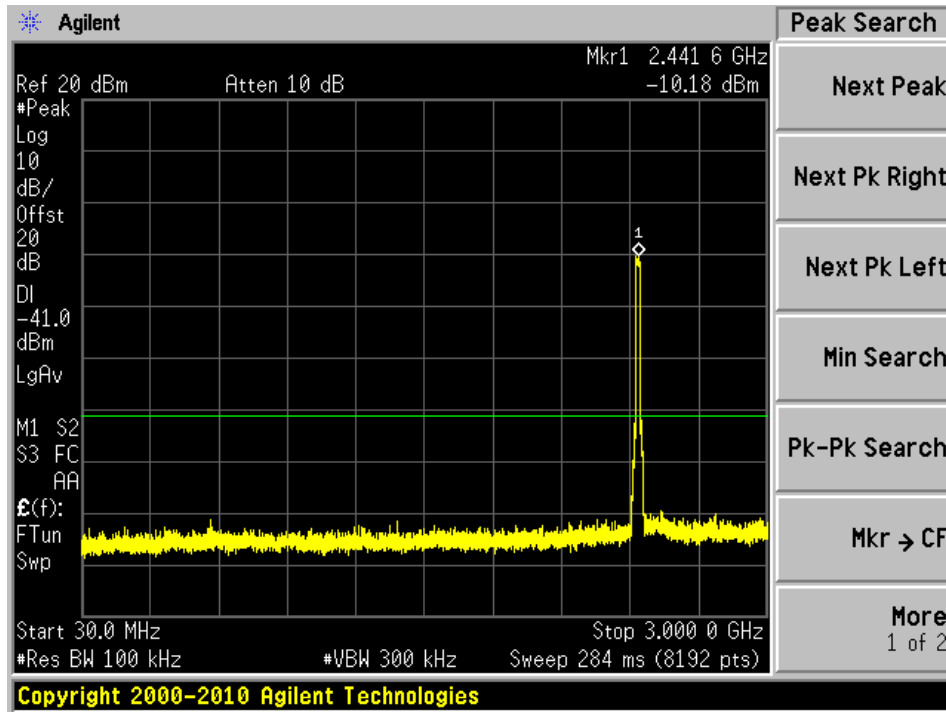

802.11n20-2437 MHz (3-26 GHz)

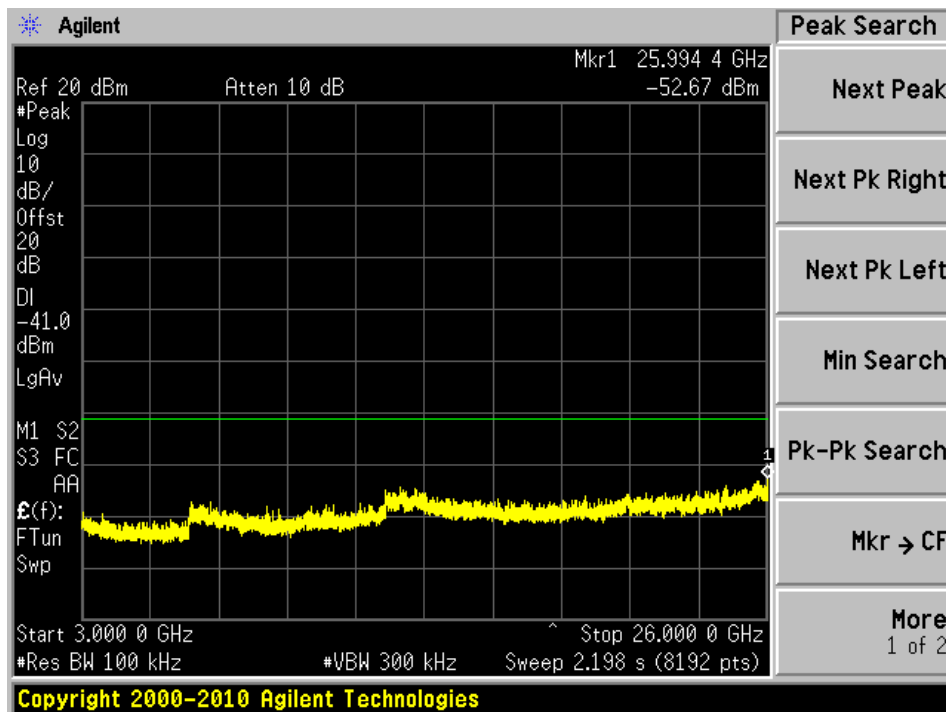

802.11n20-2462 MHz (30 MHz-3 GHz)

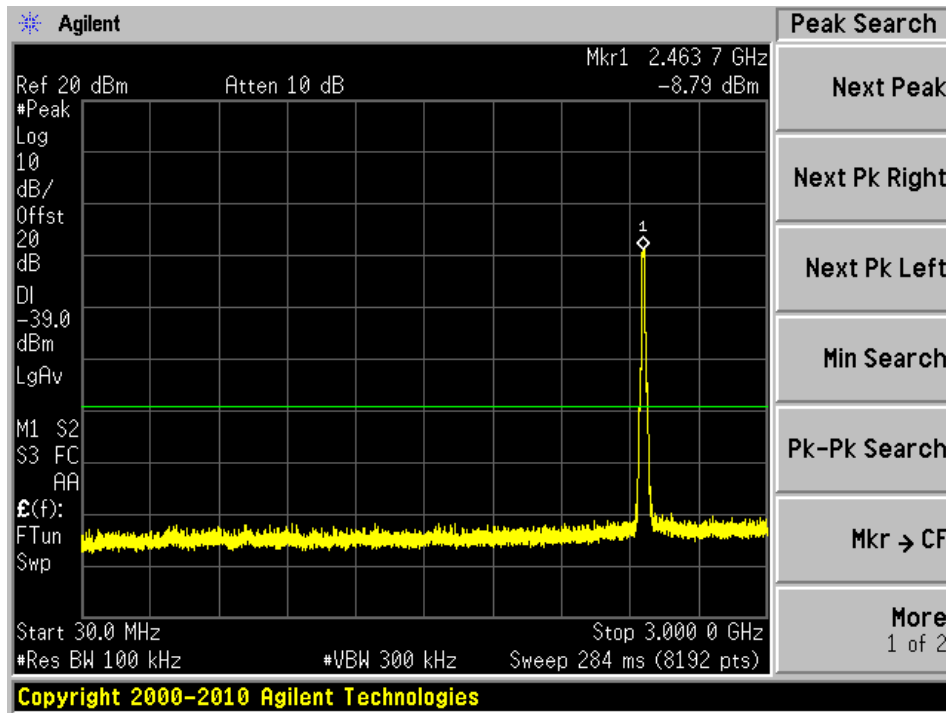

802.11n20-2462 MHz (3-26 GHz)

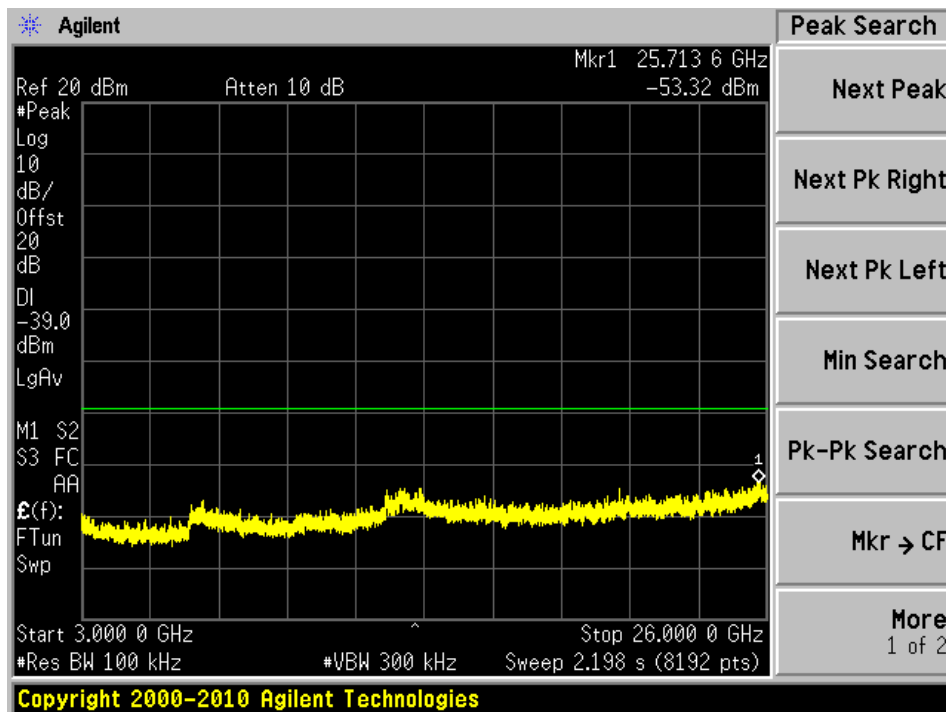

### Band Edge

#### 802.11b - Low Band Edge

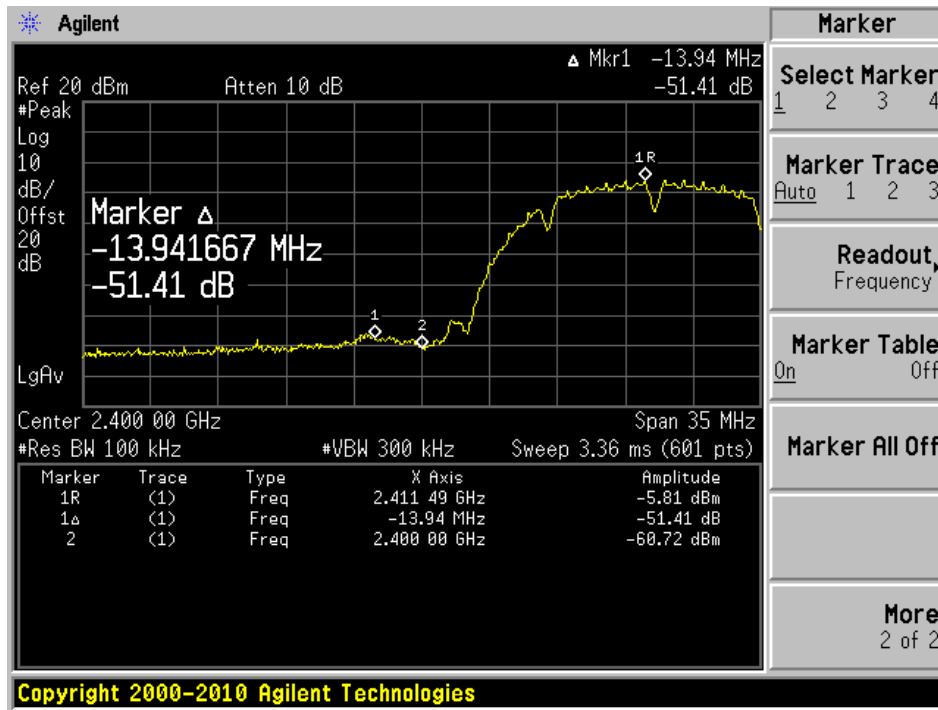

#### 802.11b - High Band Edge

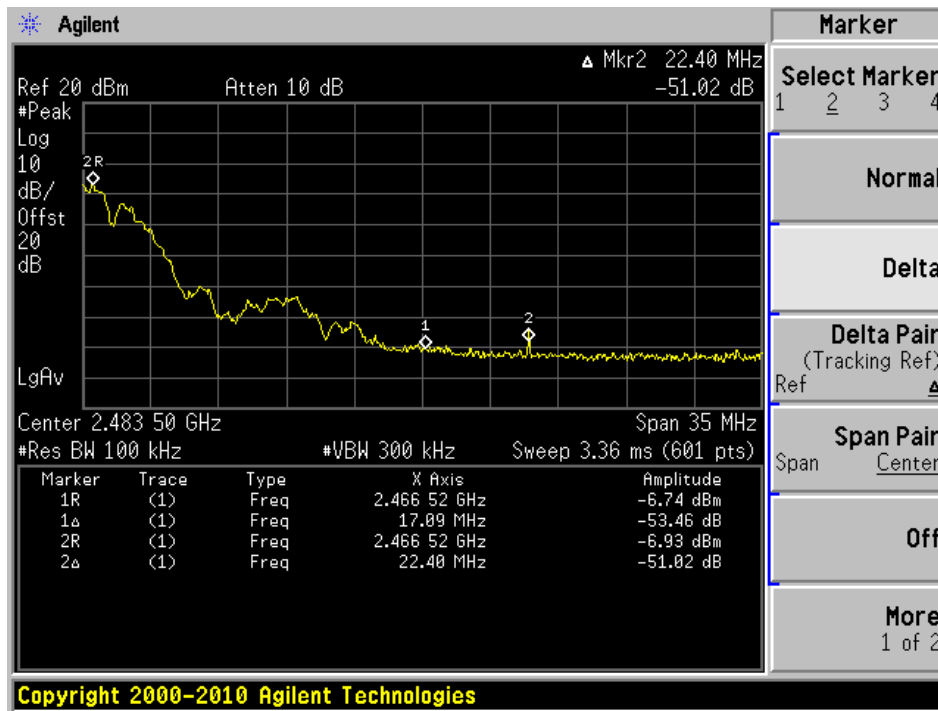



802.11g - Low Band Edge

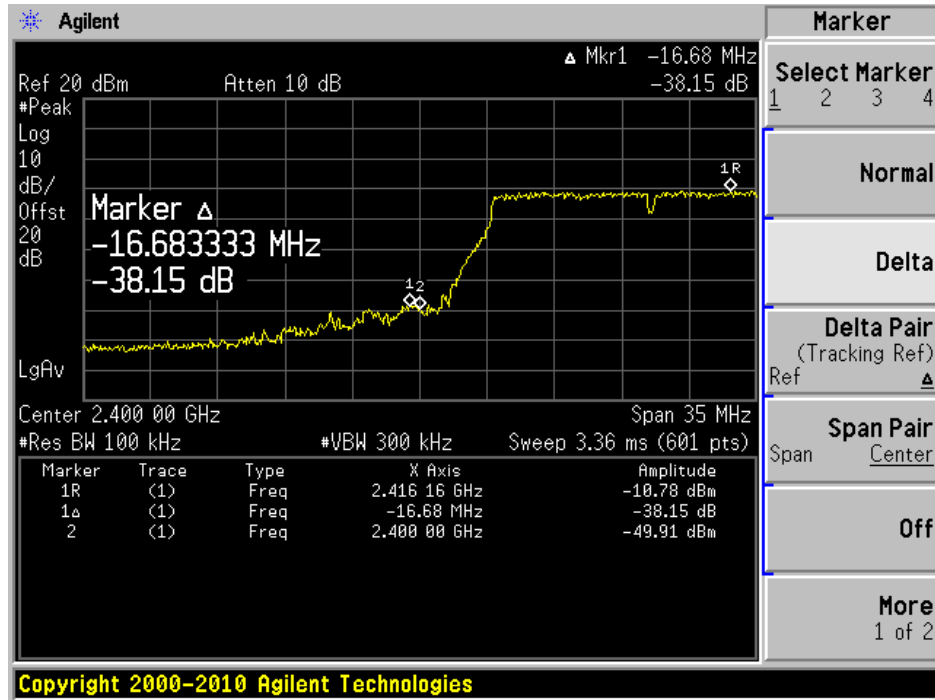

802.11g - High Band Edge

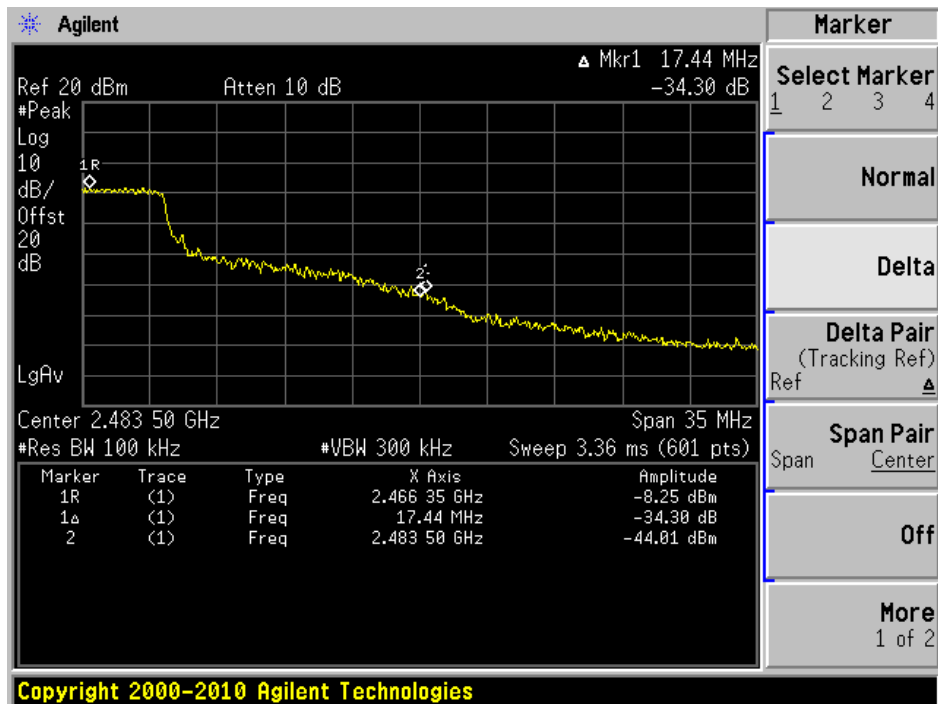

802.11n20 - Low Band Edge

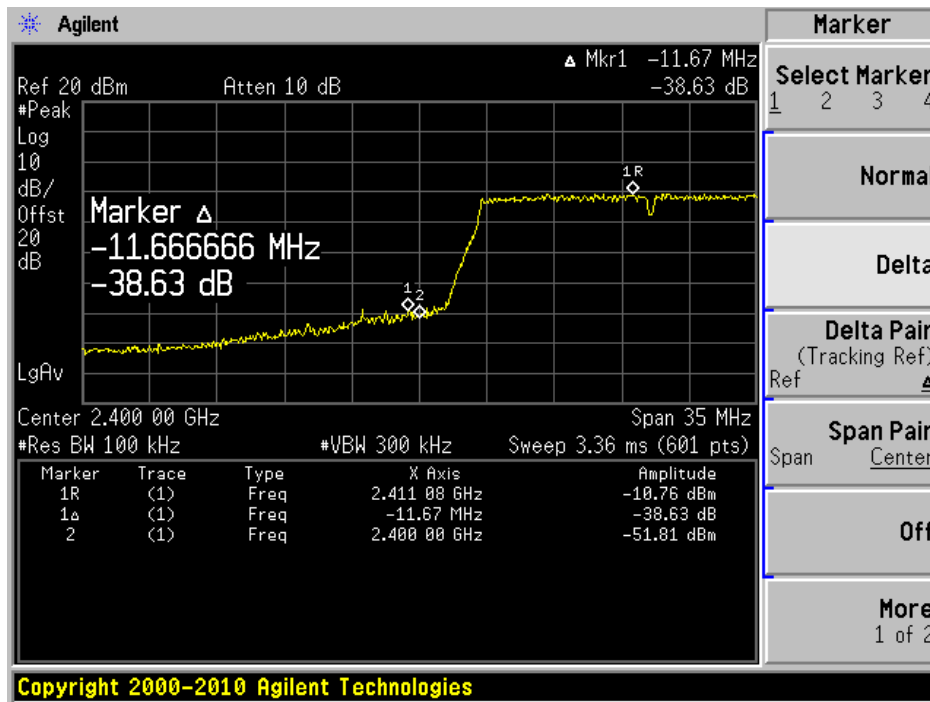

802.11n20 - High Band Edge

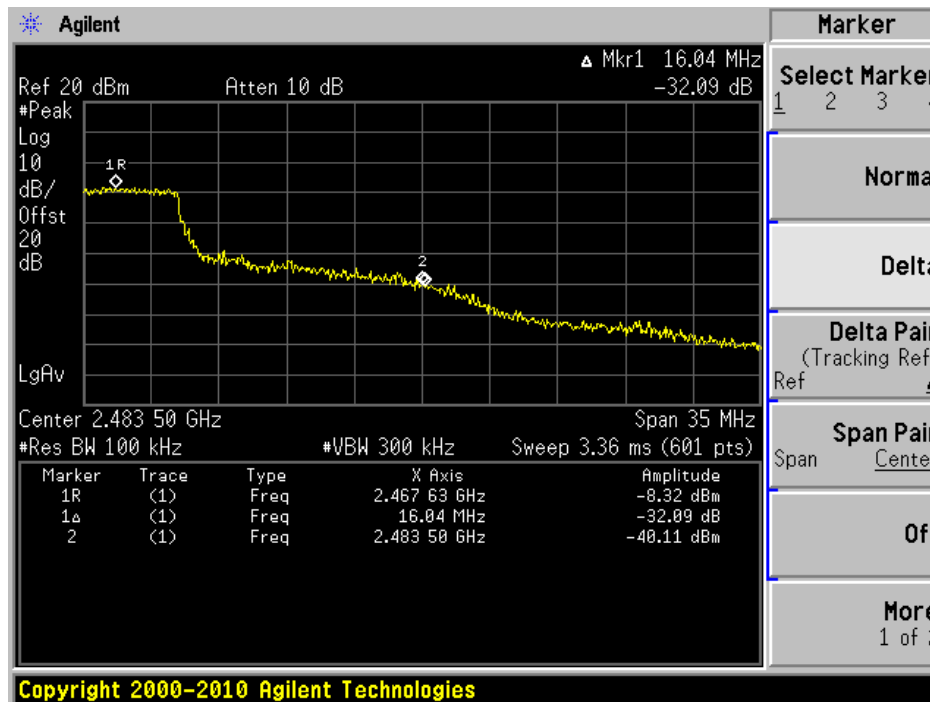

## 11 FCC §15.247(e) & ICC RSS-247 §5.2 - Power Spectral Density

### 11.1 Applicable Standards

According to FCC §15.247(e), for digitally modulated systems, the power spectral density conducted from the intentional radiator to the antenna shall not be greater than 8 dBm in any 3 kHz band during any time interval of continuous transmission.

According to RSS-247 §5.2(2), DTSs include systems that employ digital modulation techniques resulting in spectral characteristics similar to direct sequence systems. The following applies to the bands 902-928 MHz and 2400- 2483.5 MHz<sup>1</sup>: The transmitter power spectral density conducted from the transmitter to the antenna shall not be greater than 8 dBm in any 3 kHz band during any time interval of continuous transmission. This power spectral density shall be determined in accordance with the provisions of Section 5.4(4), (i.e. the power spectral density shall be determined using the same method as is used to determine the conducted output power).

### 11.2 Measurement Procedure

The measurements are based on FCC KDB 558074 D01 DTS Meas Guidance v03r03: Guidance for Performing Compliance Measurements on Digital Transmission Systems (DTS) Operating Under §15.247 section 10: Maximum power spectral density level in the fundamental emission

### 11.3 Test Equipment List and Details

Manufacturer	Description	Model No.	Serial No.	Calibration Date	Calibration Interval
Rohde & Schwarz	Spectrum Analyzer	FSQ	1155.5001.26	2015-03-09	1 year
Agilent	Spectrum Analyzer	E4440A	US42221851	2015-06-23	1 year
-	SMA Cable	-	C0001	Each Time <sup>1</sup>	N/A
Mini-Circuits	Attenuator	BW-S20W5	1430	Each Time <sup>1</sup>	N/A

Note<sup>1</sup>: cable and attenuator included in the test set-up will be checked each time before testing.

*Statement of Traceability: BACL Corp. attests that all calibrations have been performed per the A2LA requirements, traceable to the NIST.*

### 11.4 Test Environmental Conditions

<b>Temperature:</b>	21-25 °C
<b>Relative Humidity:</b>	42-45 %
<b>ATM Pressure:</b>	102.1-103.7 kPa

*The testing was performed by Leonard Gray on 2015-12-22 in RF site.*

**11.5 Test Results**

Channel	Frequency (MHz)	Power Spectral Density (dBm/3kHz)	Limit (dBm/3kHz)
802.11b			
Low	2412	-22.23	8
Middle	2437	-22.50	8
High	2462	-21.22	8
802.11g			
Low	2412	-24.56	8
Middle	2437	-23.30	8
High	2462	-21.70	8
802.11n20			
Low	2412	-22.94	8
Middle	2437	-21.15	8
High	2462	-19.90	8

*Please refer to the following plots.*

802.11b-2412 MHz

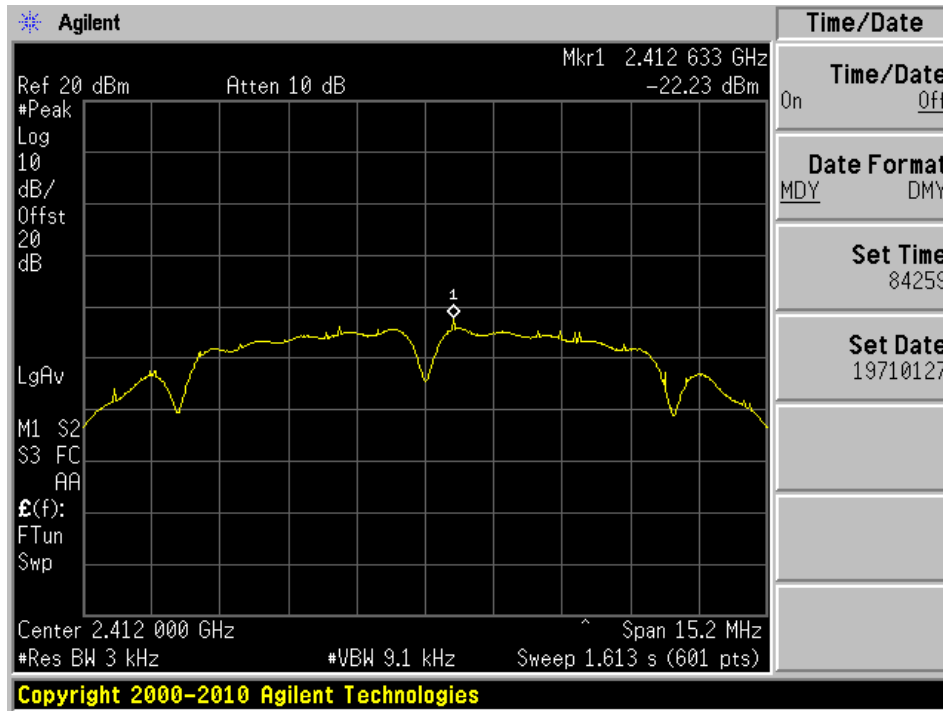

802.11b-2437 MHz

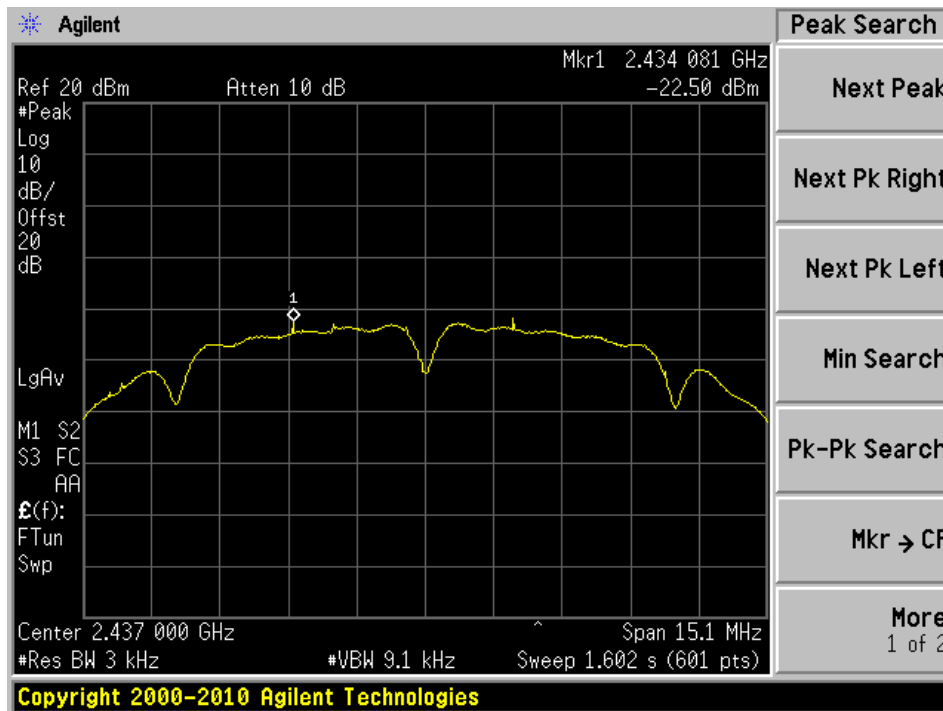

802.11b-2462 MHz

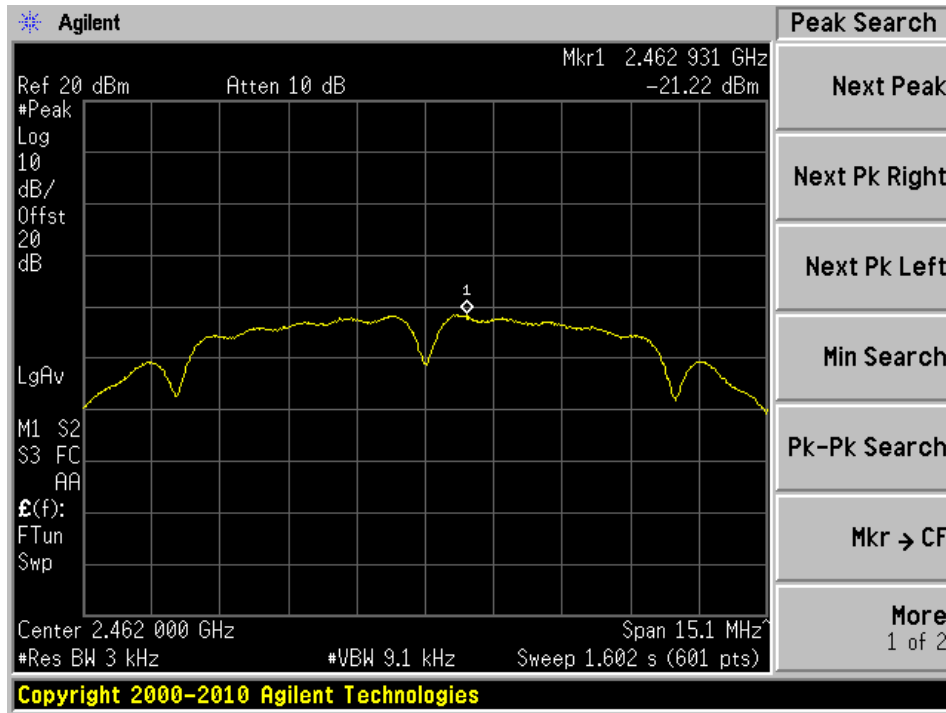

802.11g-2412 MHz

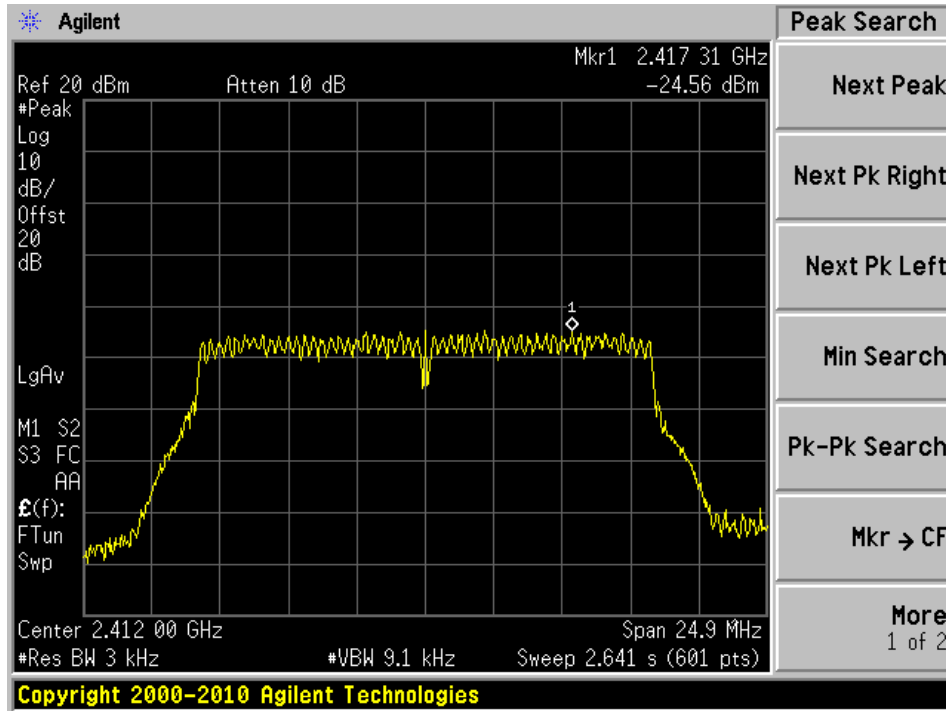

## 802.11g-2437 MHz

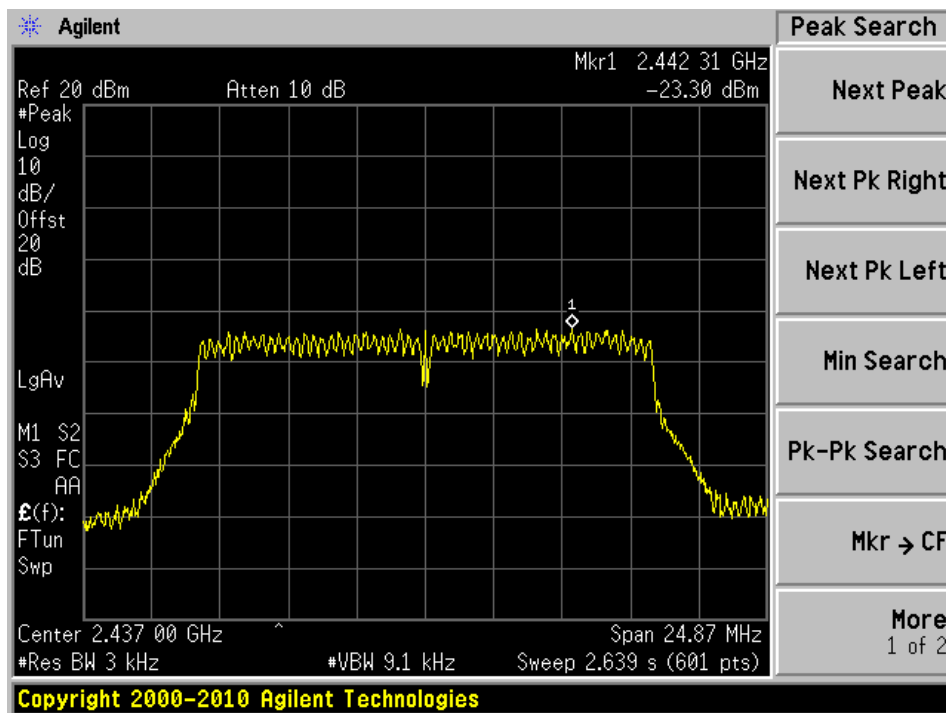

## 802.11g-2462 MHz

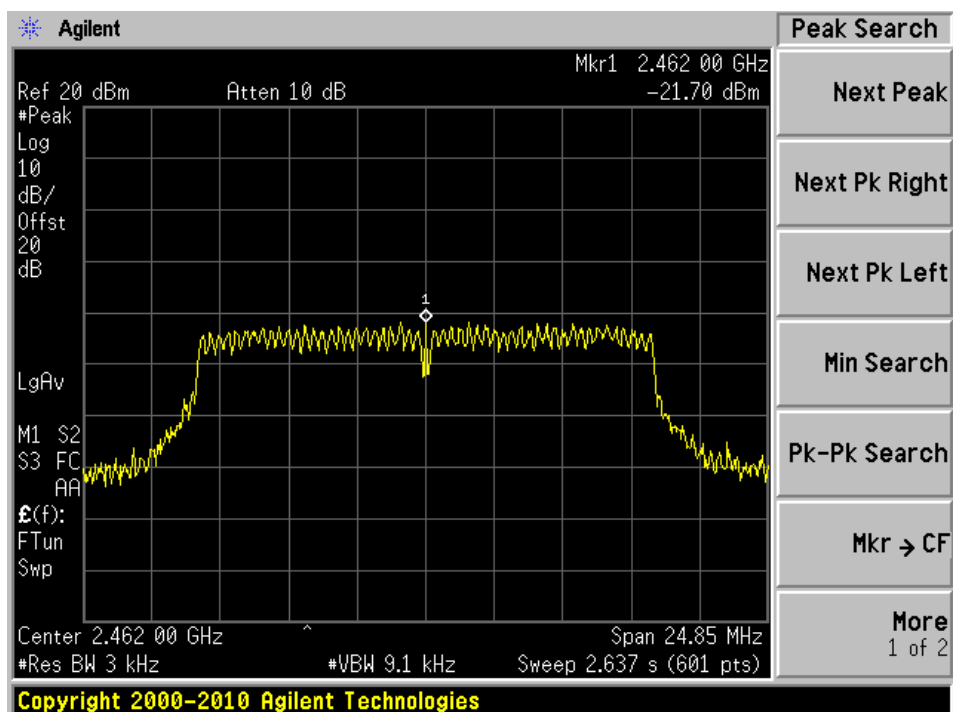

802.11n20-2412 MHz

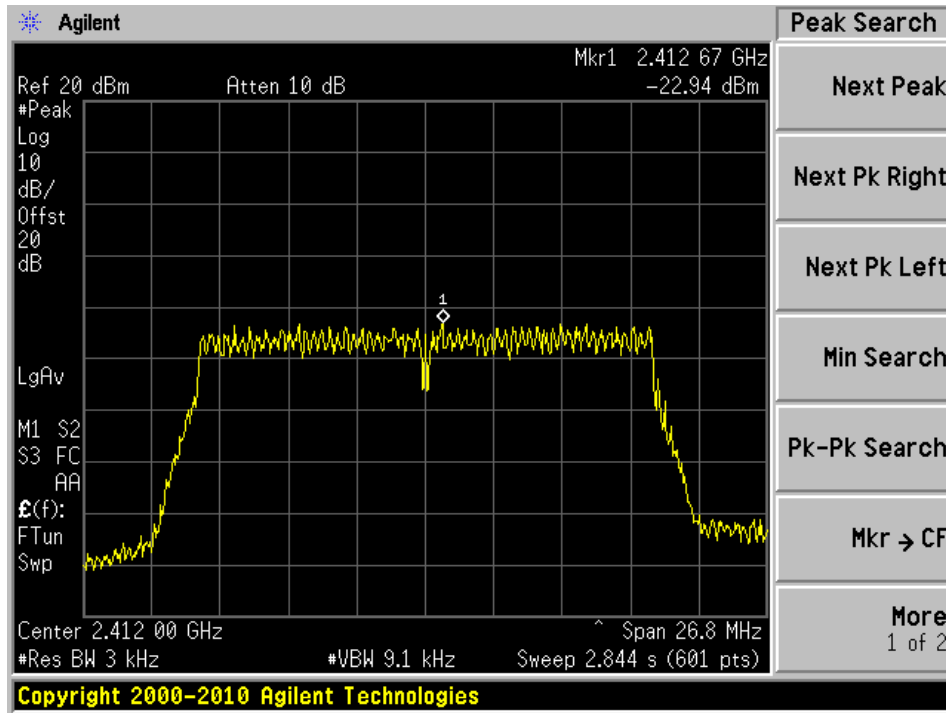

802.11n20-2437 MHz

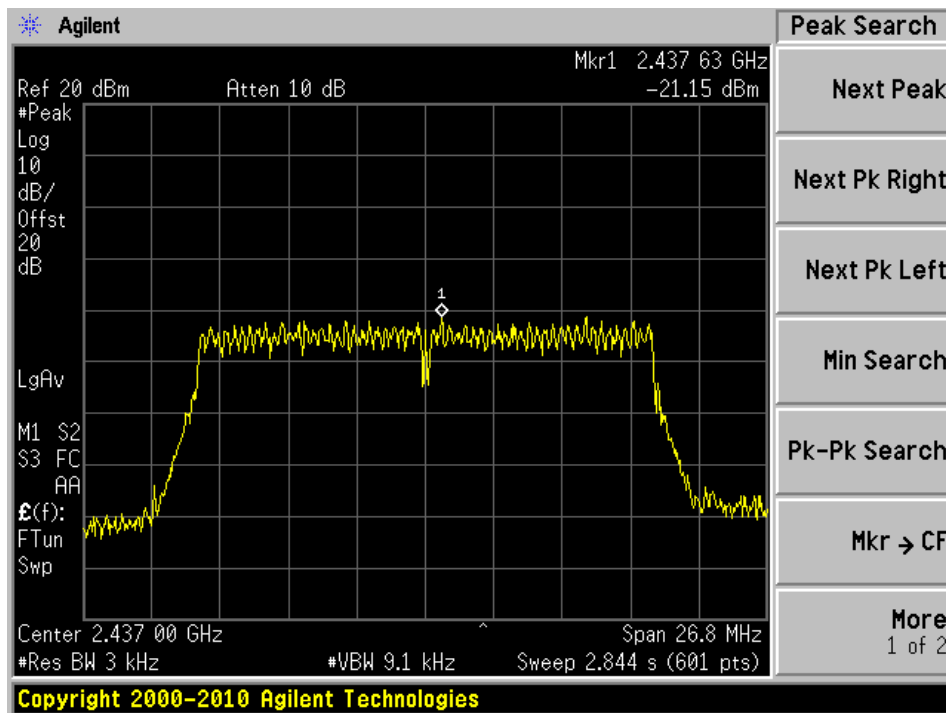



802.11n20-2462 MHz

