

This Design is given "AS IS" without warranty of any kind, either expressed or implied.

ASPEN - MEMORY/LCD

DDR3 MEM

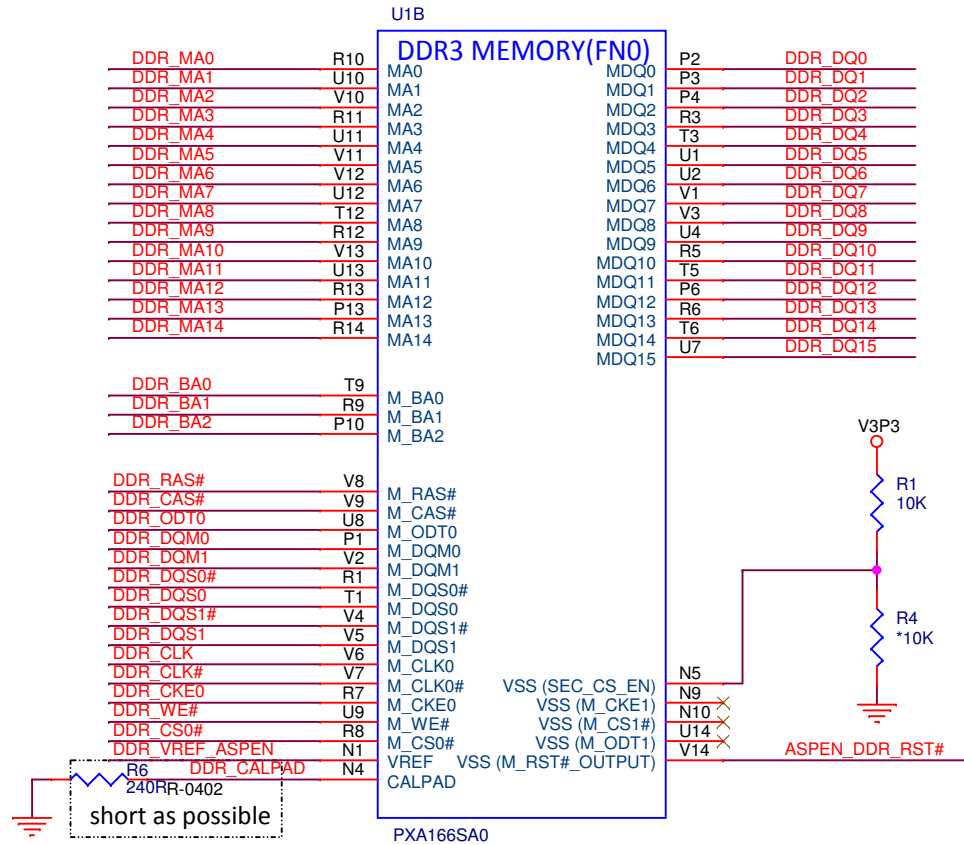
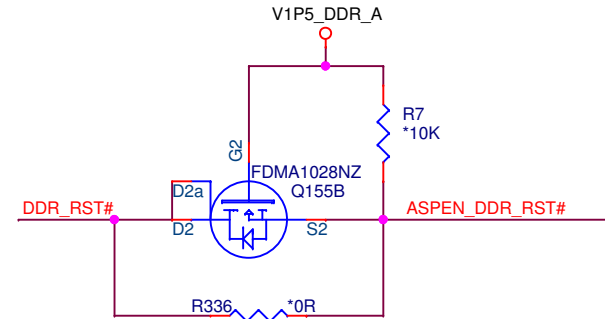
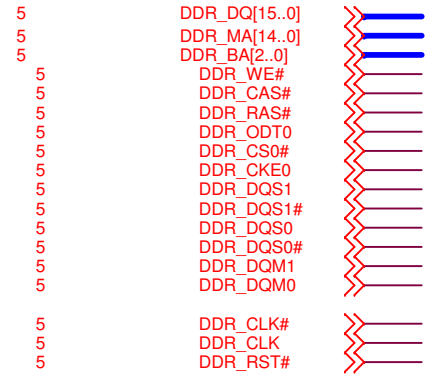

Notes:
Connect 240ohm 1% resistor to ground for CALPAD pin.

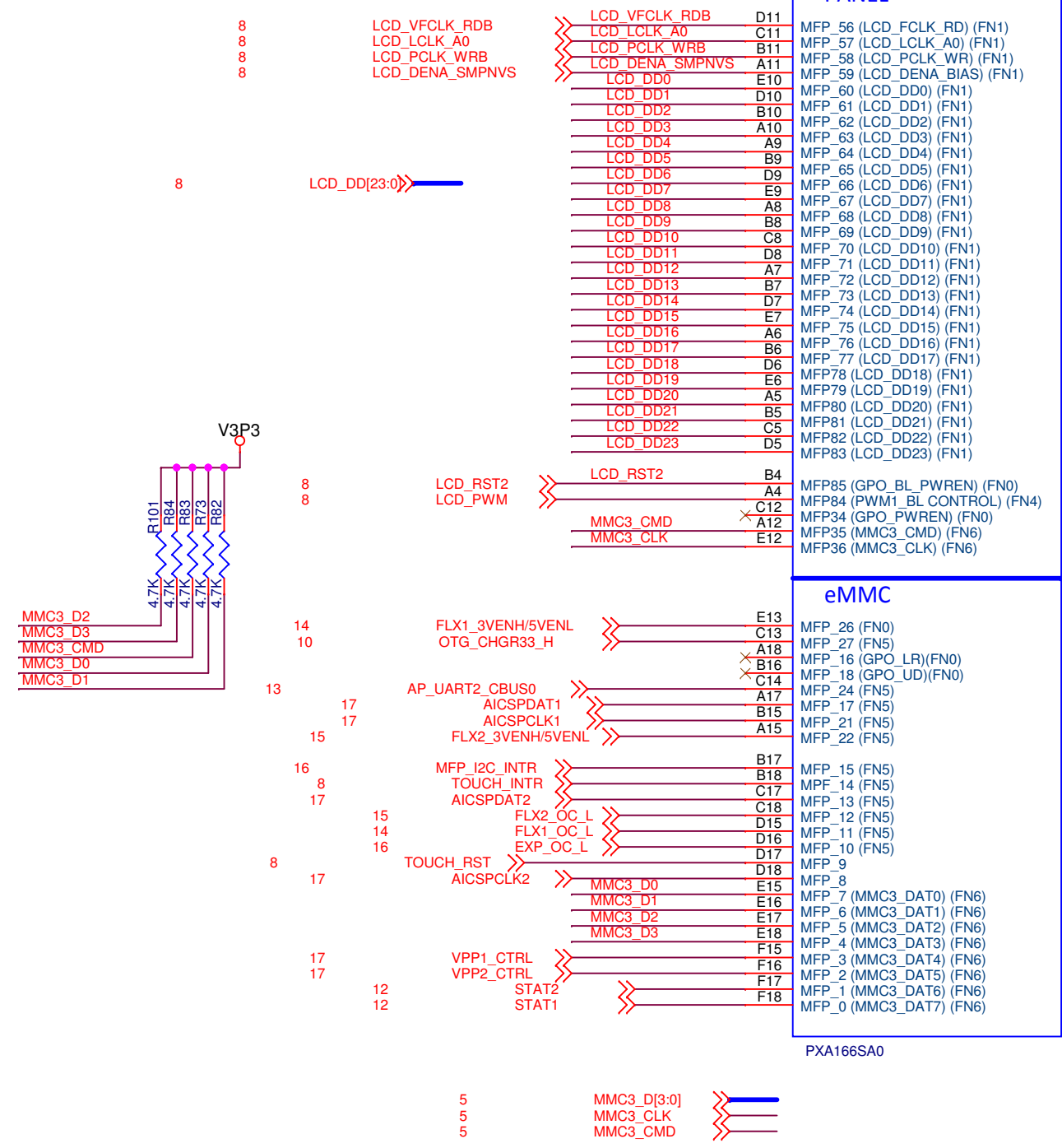
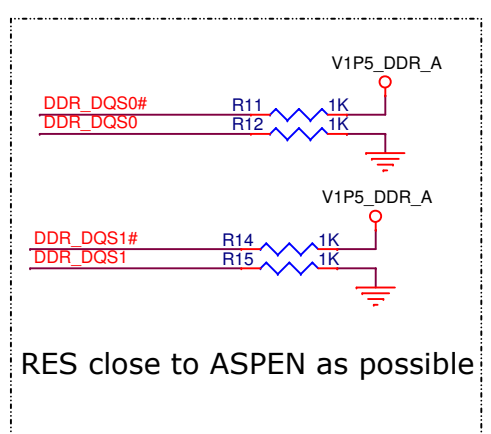
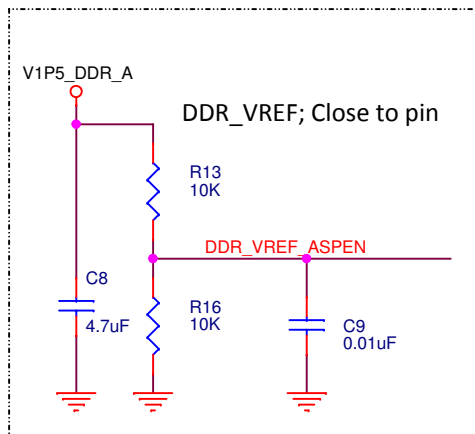

ASPEN-DEBUG/SDIO/SSP/UART/MISC

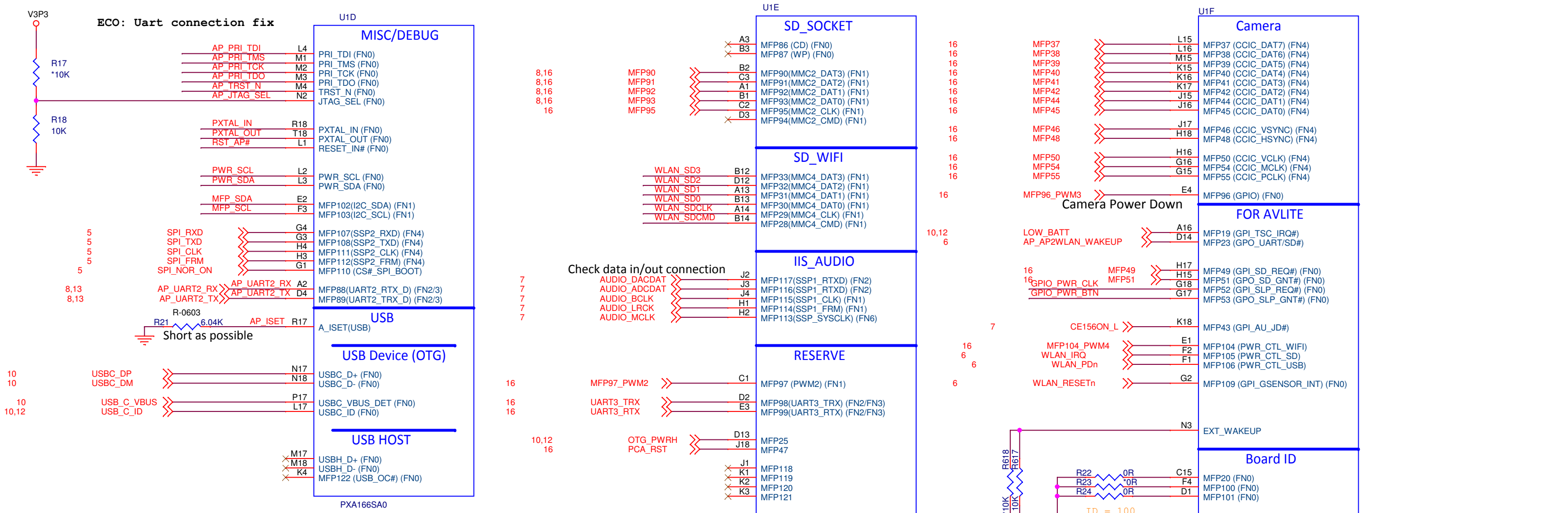

Notes:
 1. MFP110 is dedicated for SPI NOR FLASH BOOT purpose
 2. A_ISET: connect 6.04Kohm 1% resistor to ground

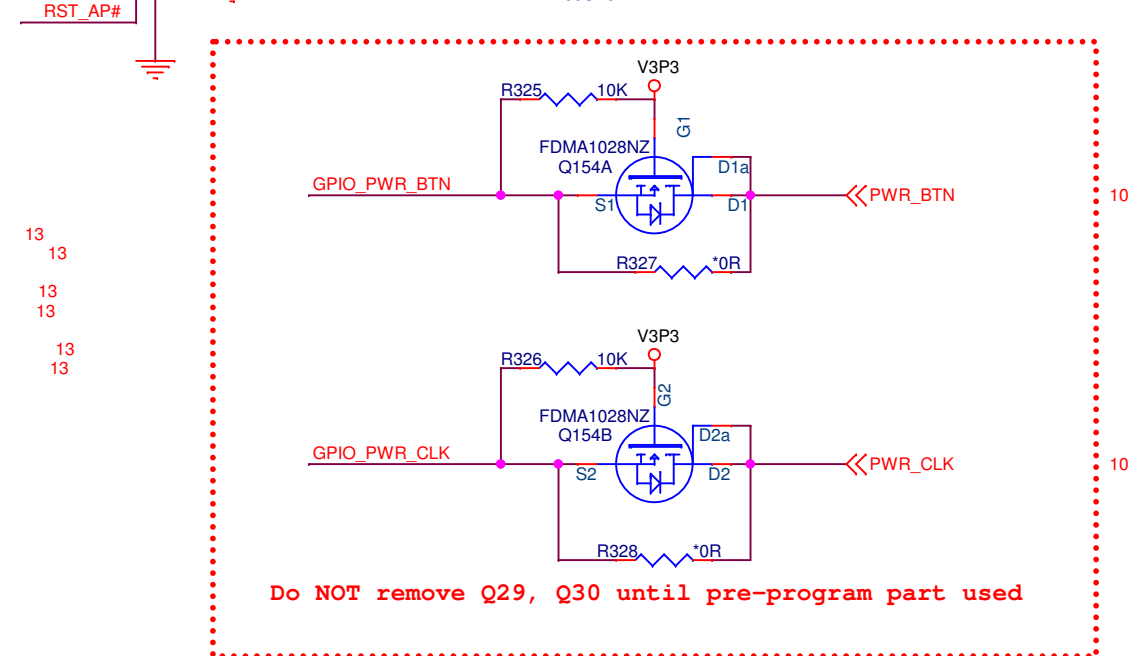
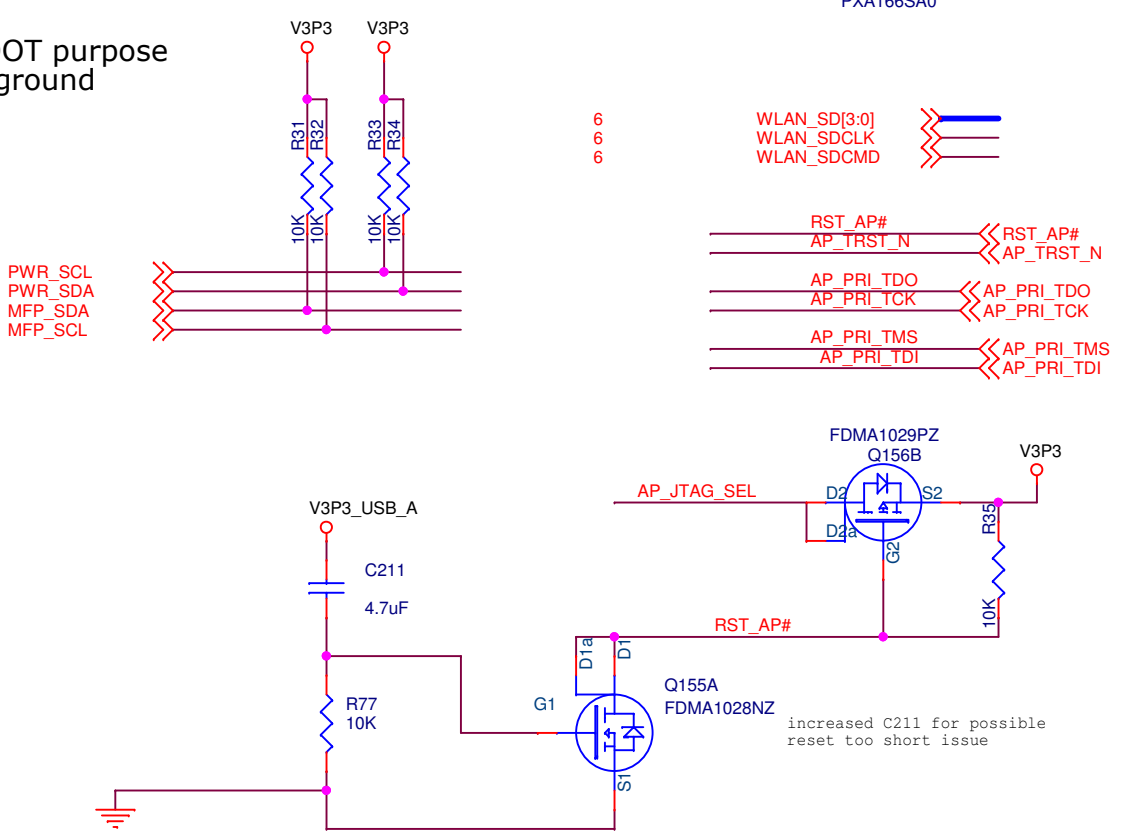
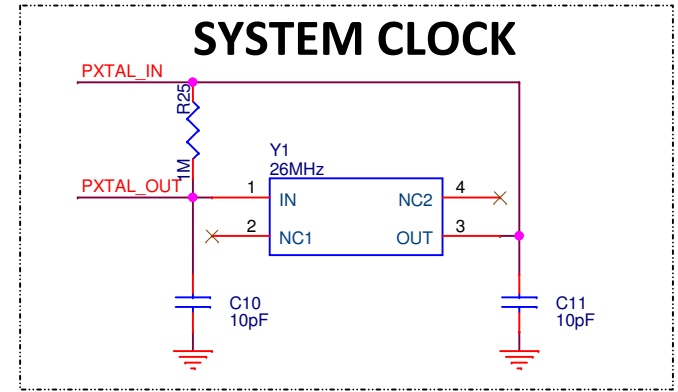

ASPEN - Power

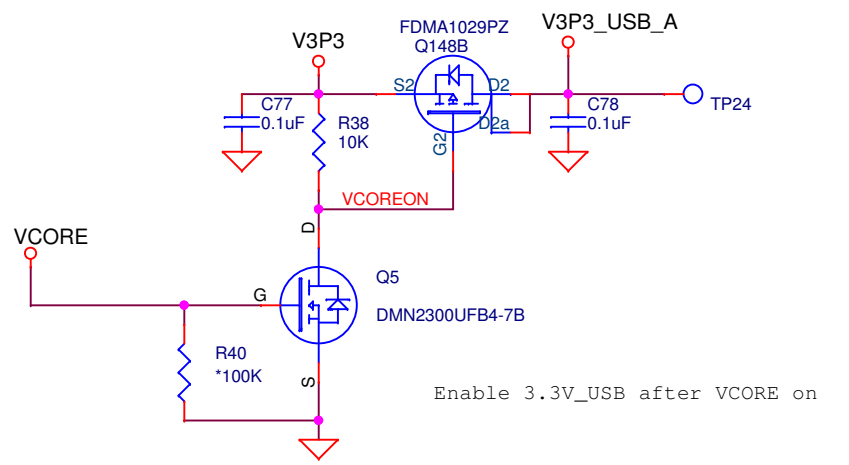
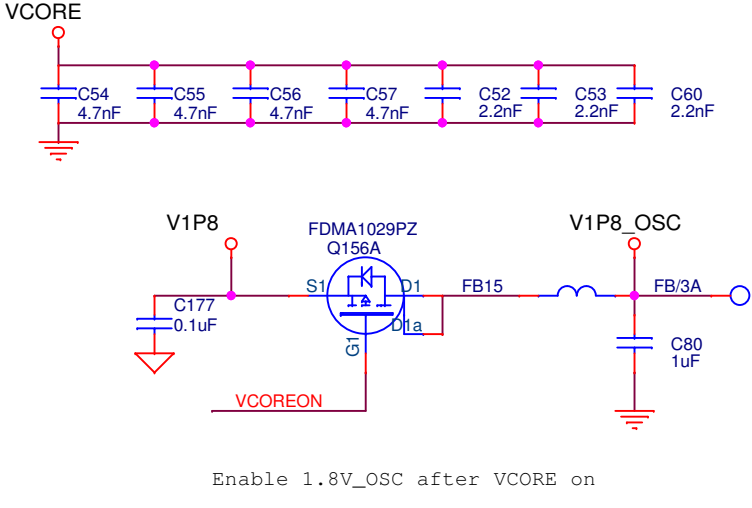
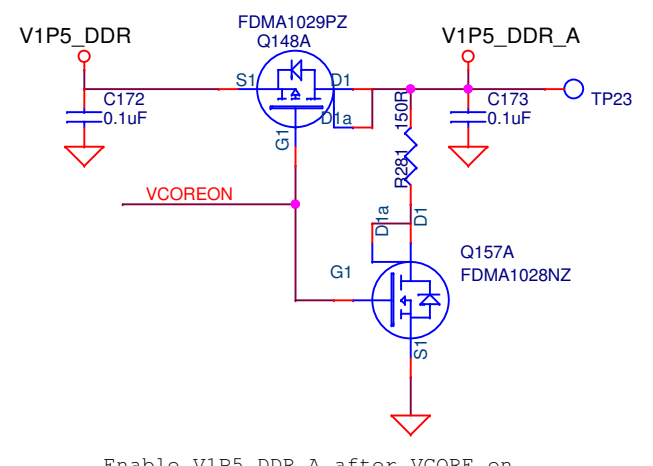
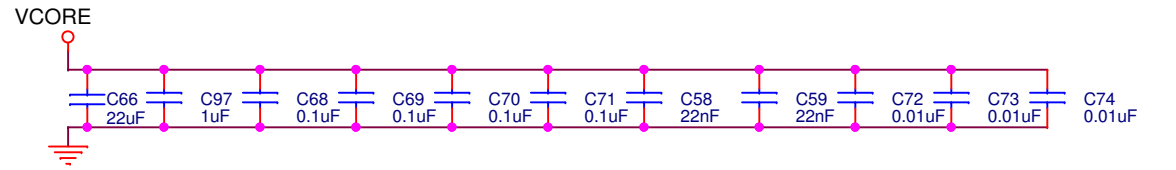
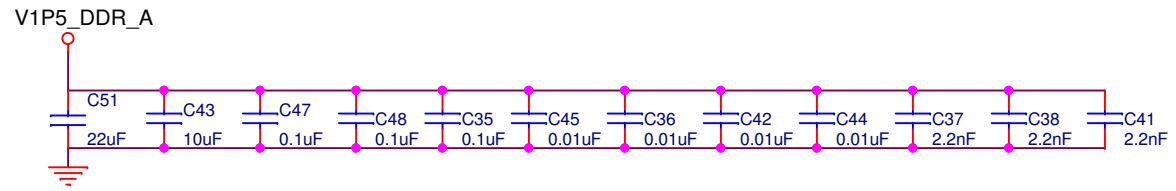
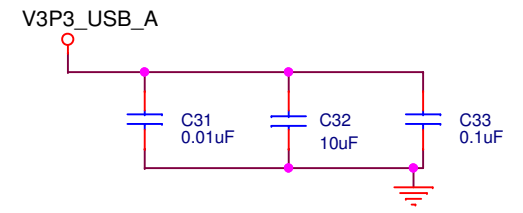
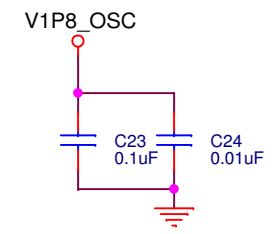
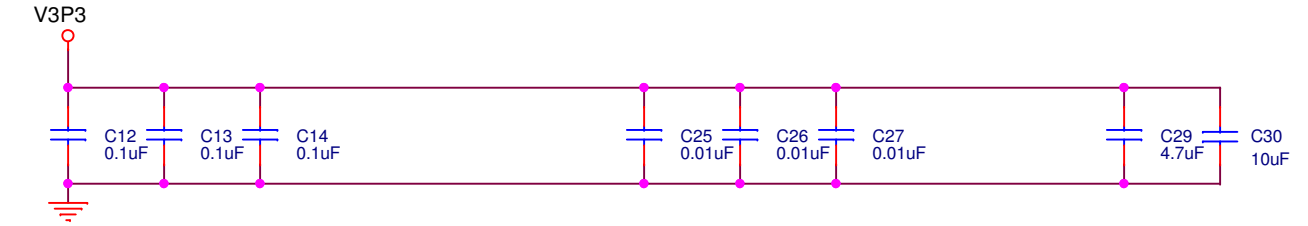
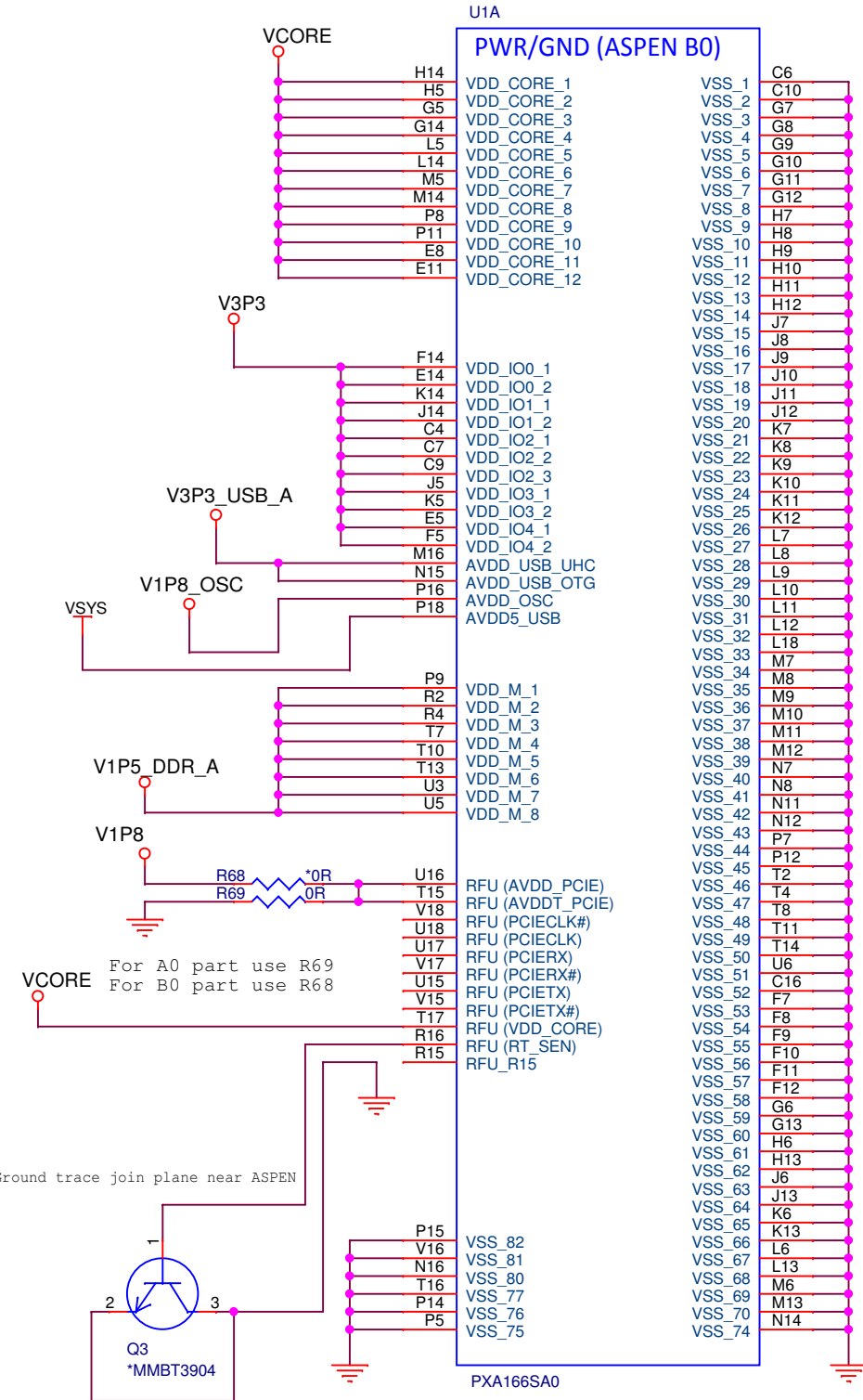

Footprint 4Gb 512Mbytes MAX Part Used 1Gb 128MBytes

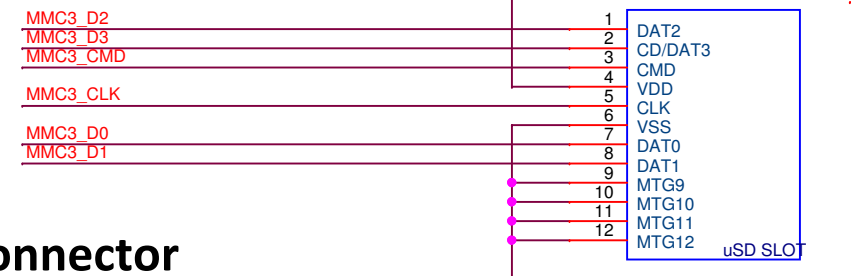
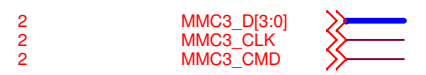
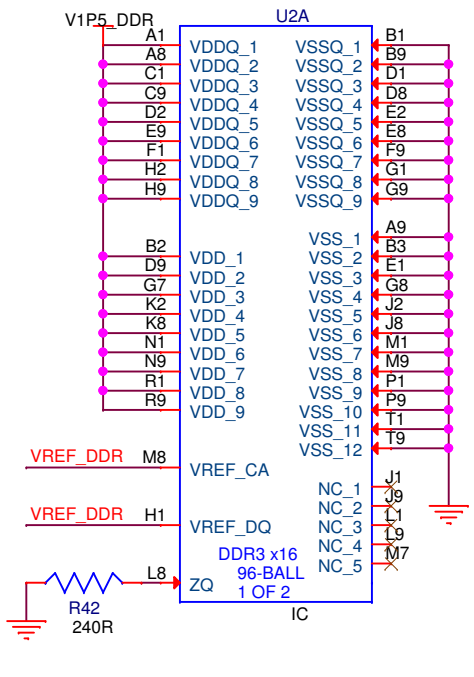
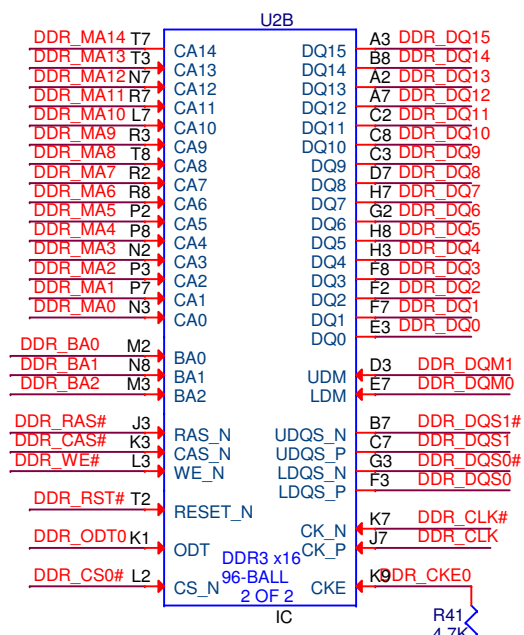
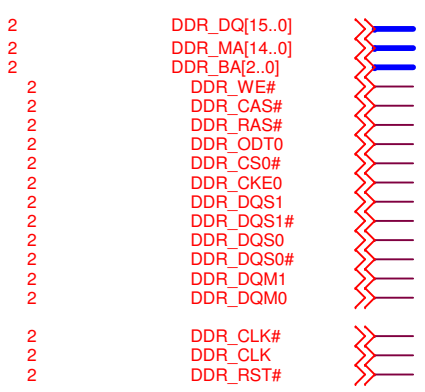

SD/MMC connector FOR DEVELOPMENT USE

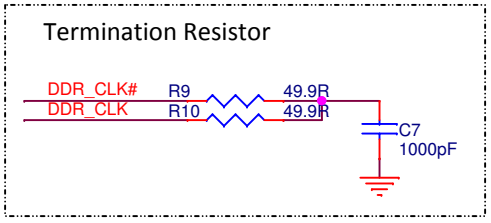
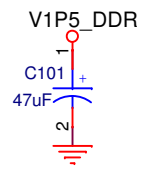
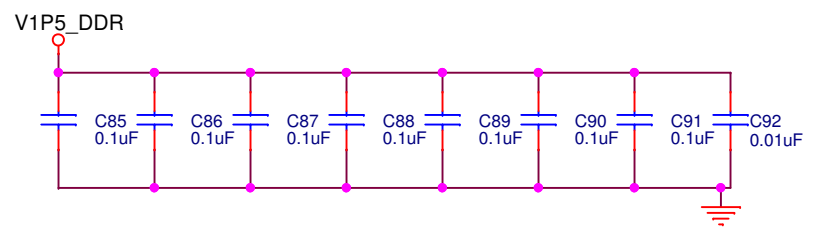
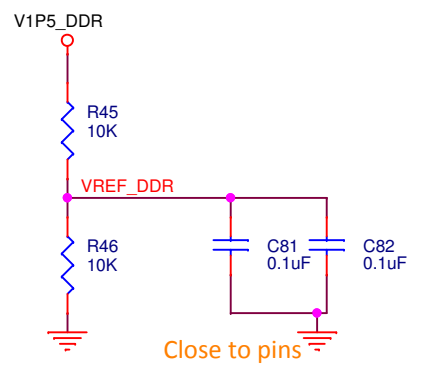

SPI NOR FLASH

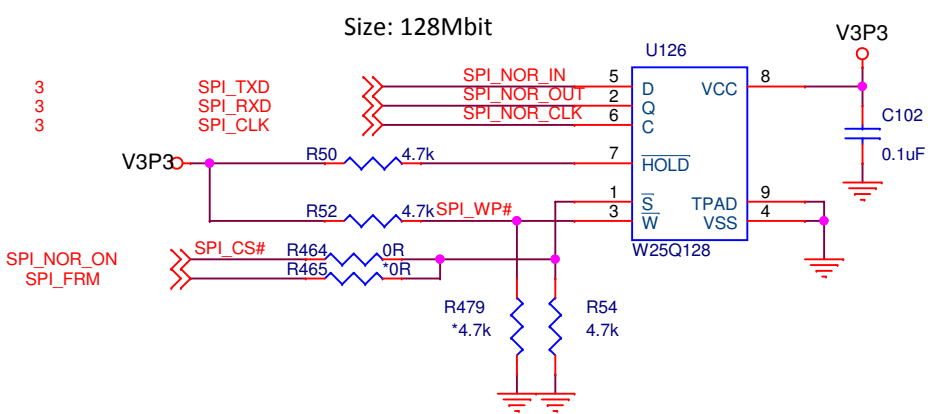

Marvell Technology Ltd		
DDR3 SDRAM		
Title	Document Number	Rev
Size	Kinoma Create	3.0
Date:	Friday, July 25, 2014	Sheet 5 of 18

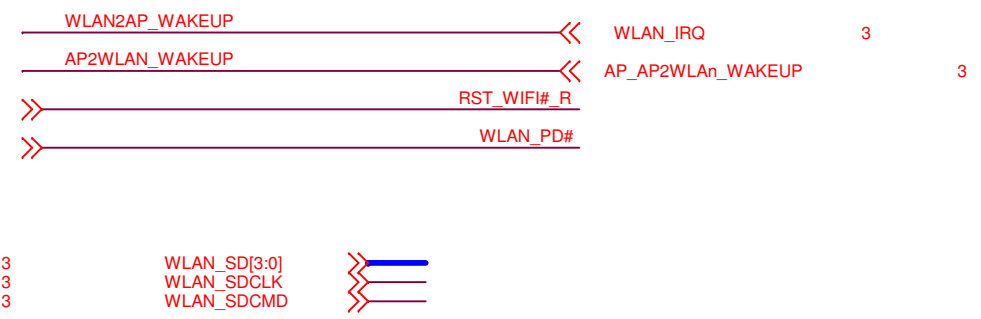
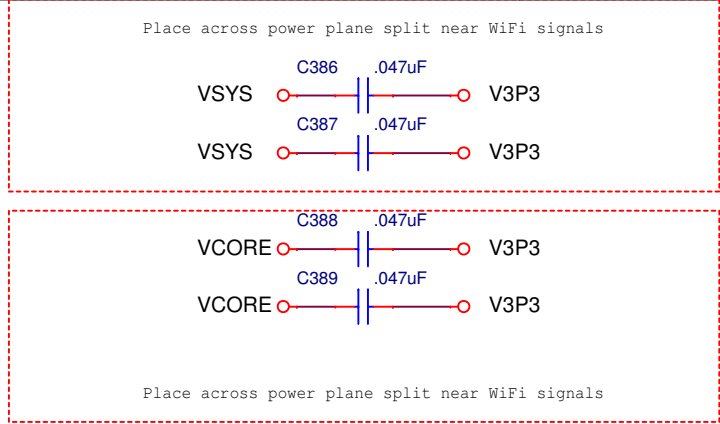

Must be outside shield

New Antenna

Note: Need location from ID

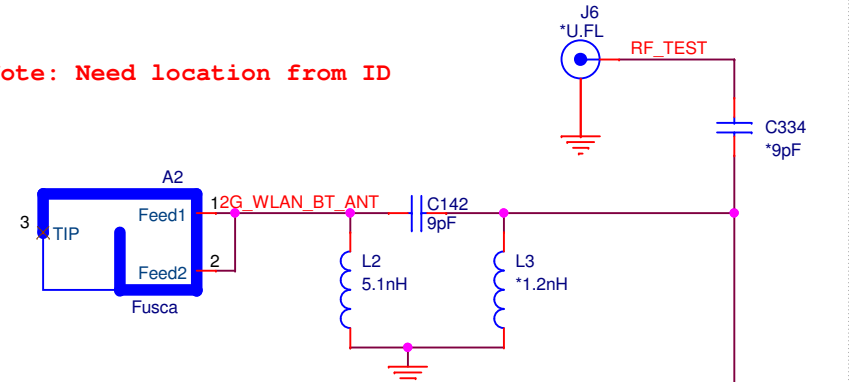

AW-NH387L 8787 WIFI

Note: Need location from ID

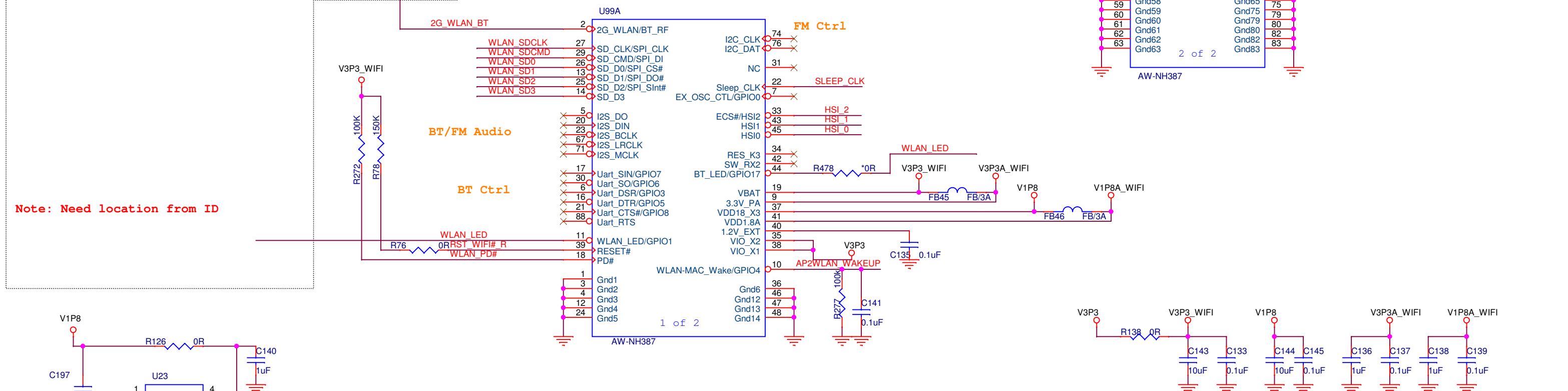

8787 Power-On Sequence:
3.3V/1.8V/SleepCLK -> RESET# High

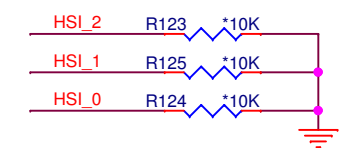
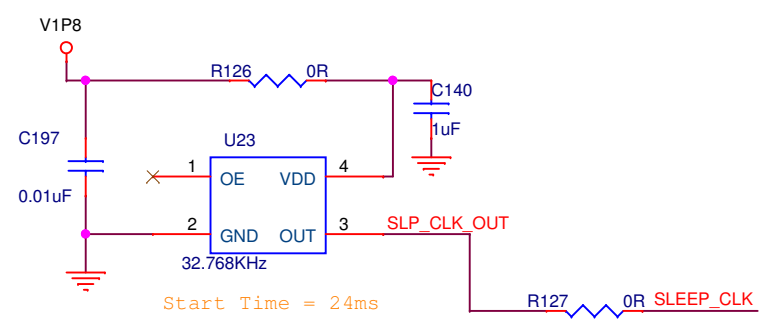

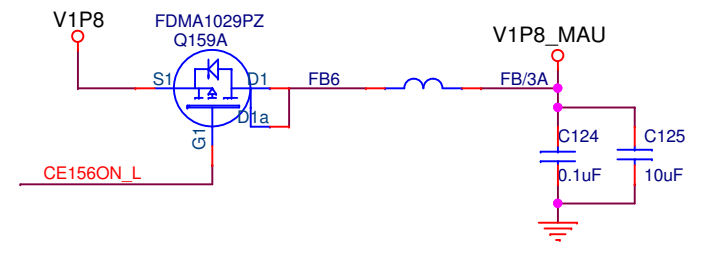
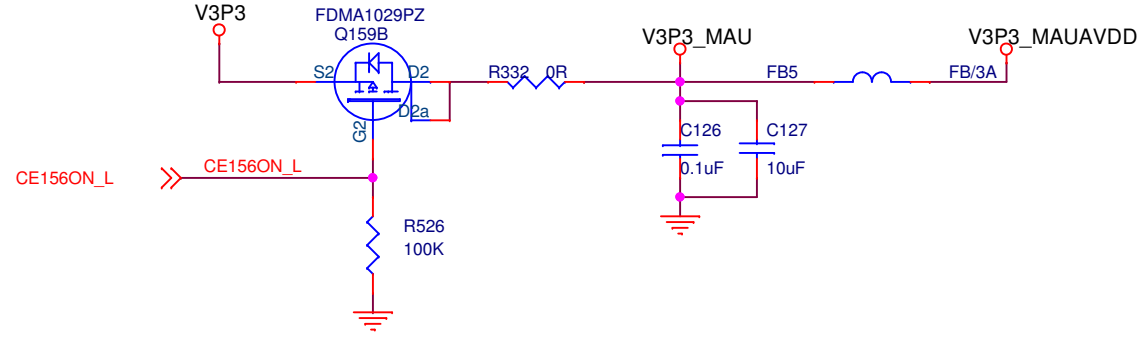
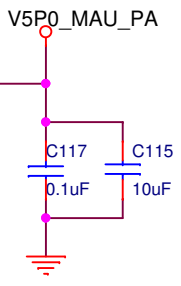
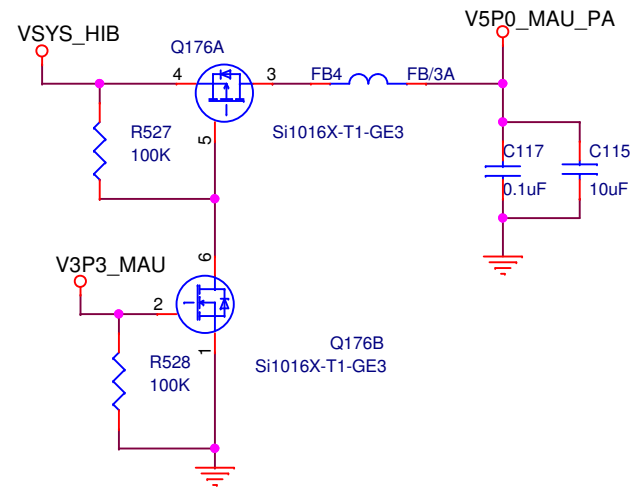

use seltech ME06027C85-382C1033

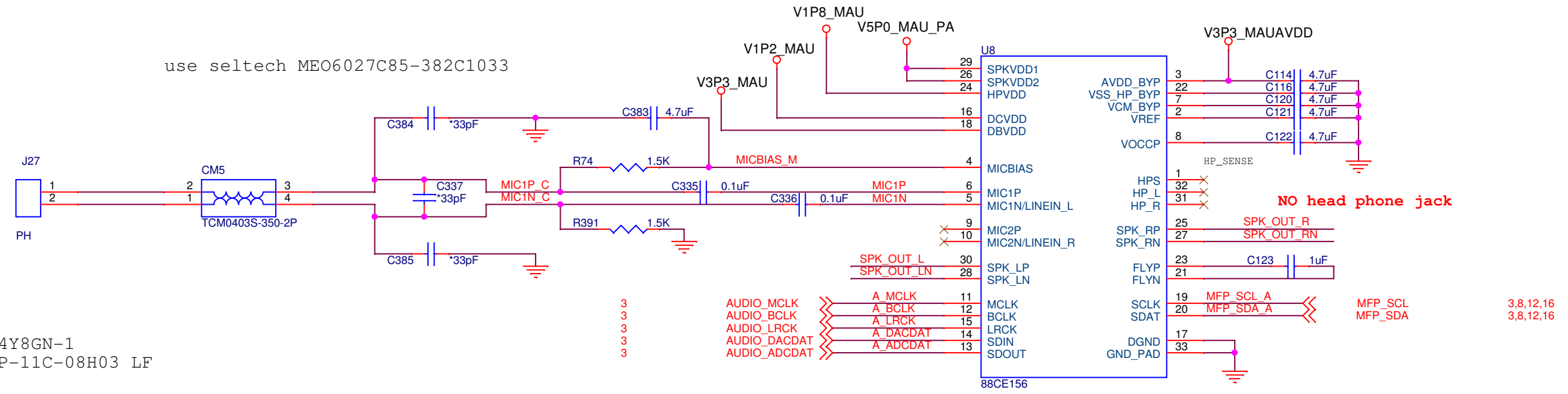

use only ONE
seltech GO2014C4Y8GN-1
bestar BMS2014P-11C-08H03 LF

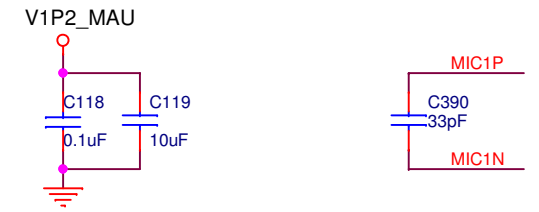
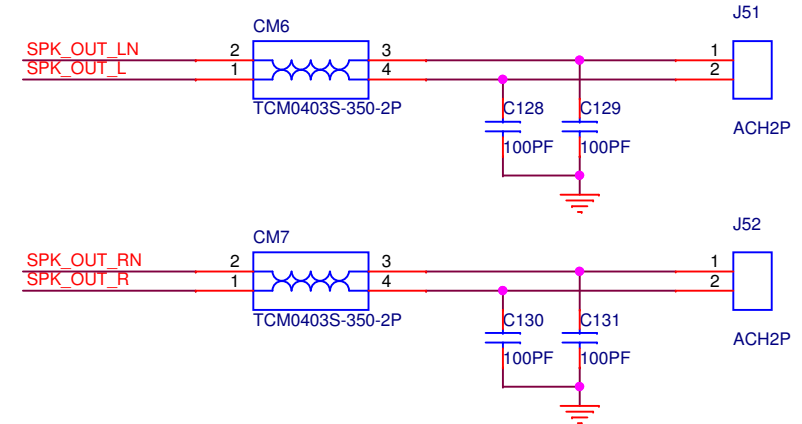

I2C linux address: 0x30

All aspen LCD + Touch signals to bridge

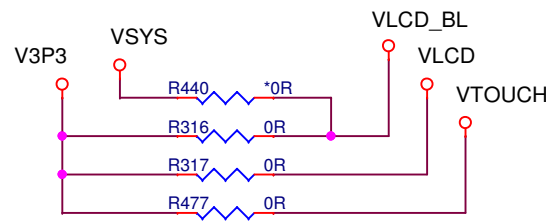

PIN SWAP OK

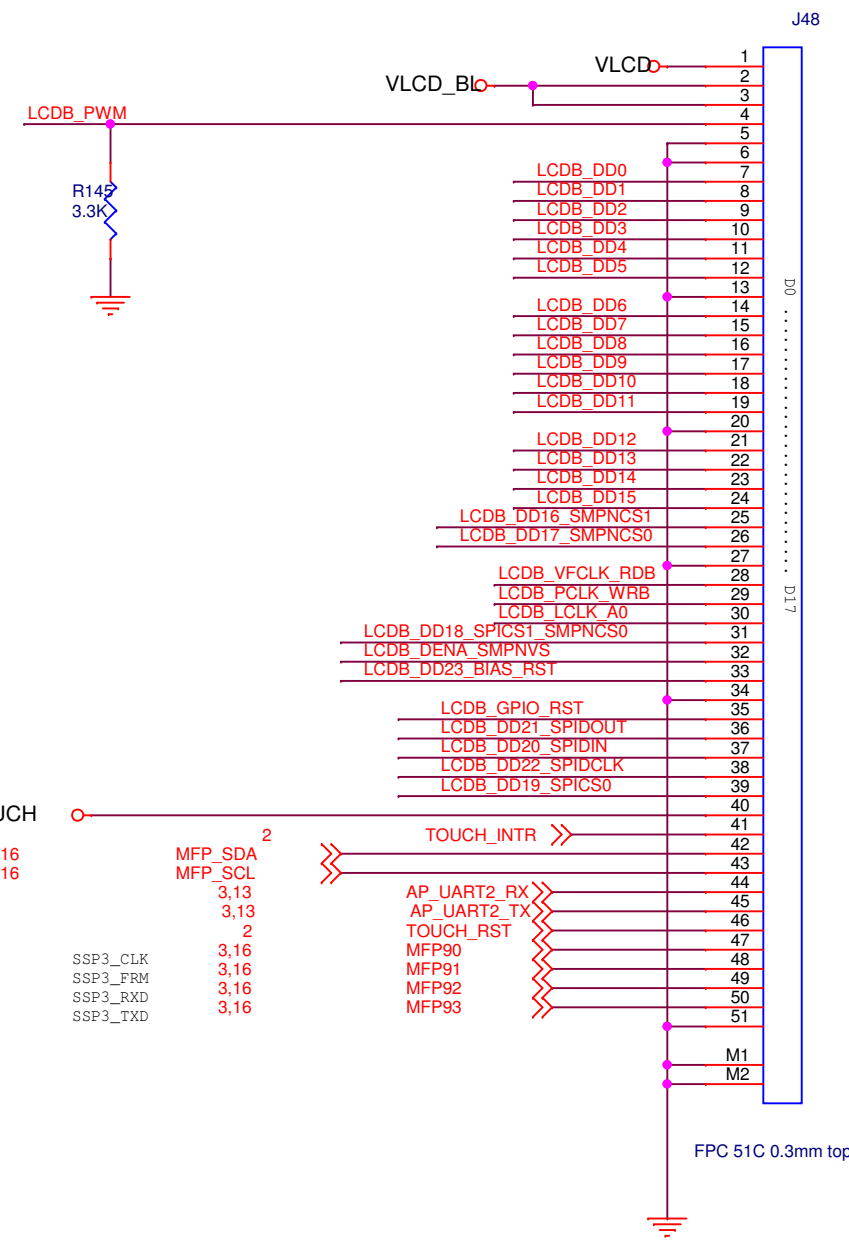
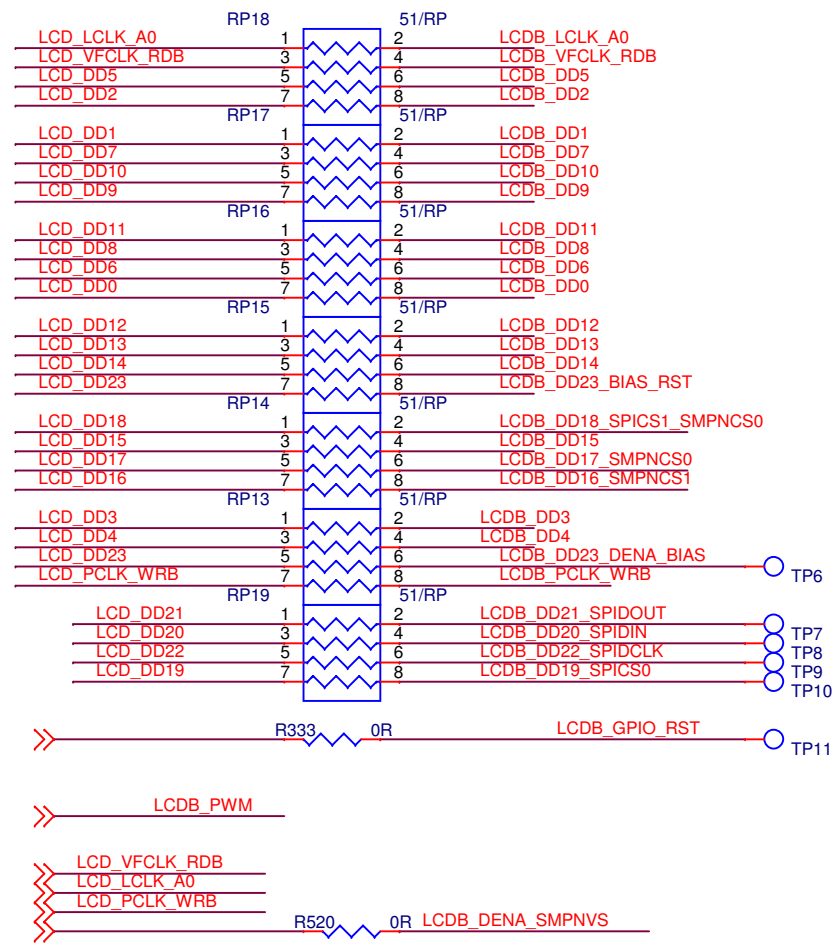

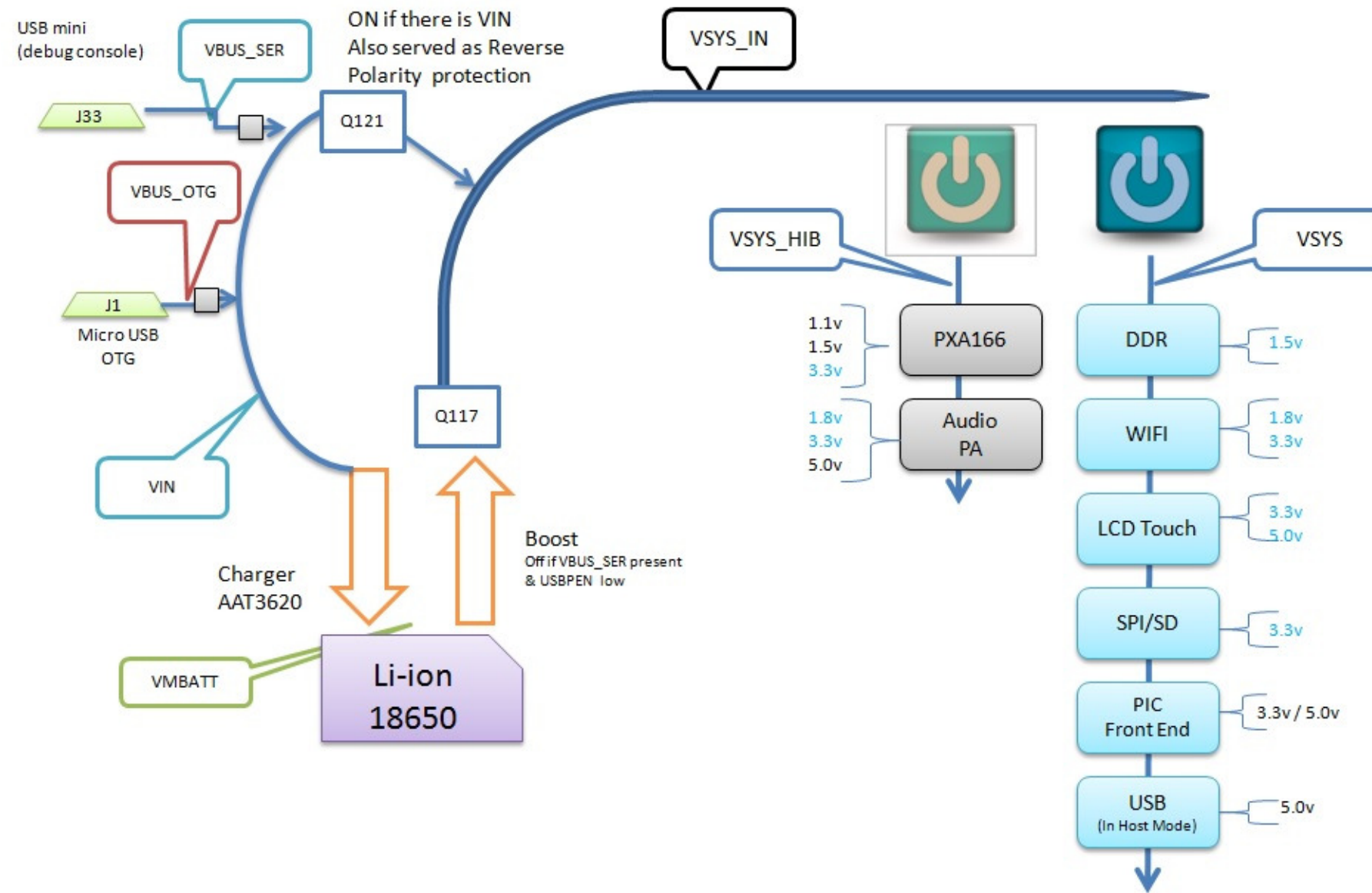

Power Button

While off - pressing will turn unit on
while on - momentary press will let software shutdown
while on - holding it for 4 second will force shut down
when bat low during hibernate, shutdown

ECO 1: U159 P3-4 swap
ICSPCLK isolation
programmer error fix D32

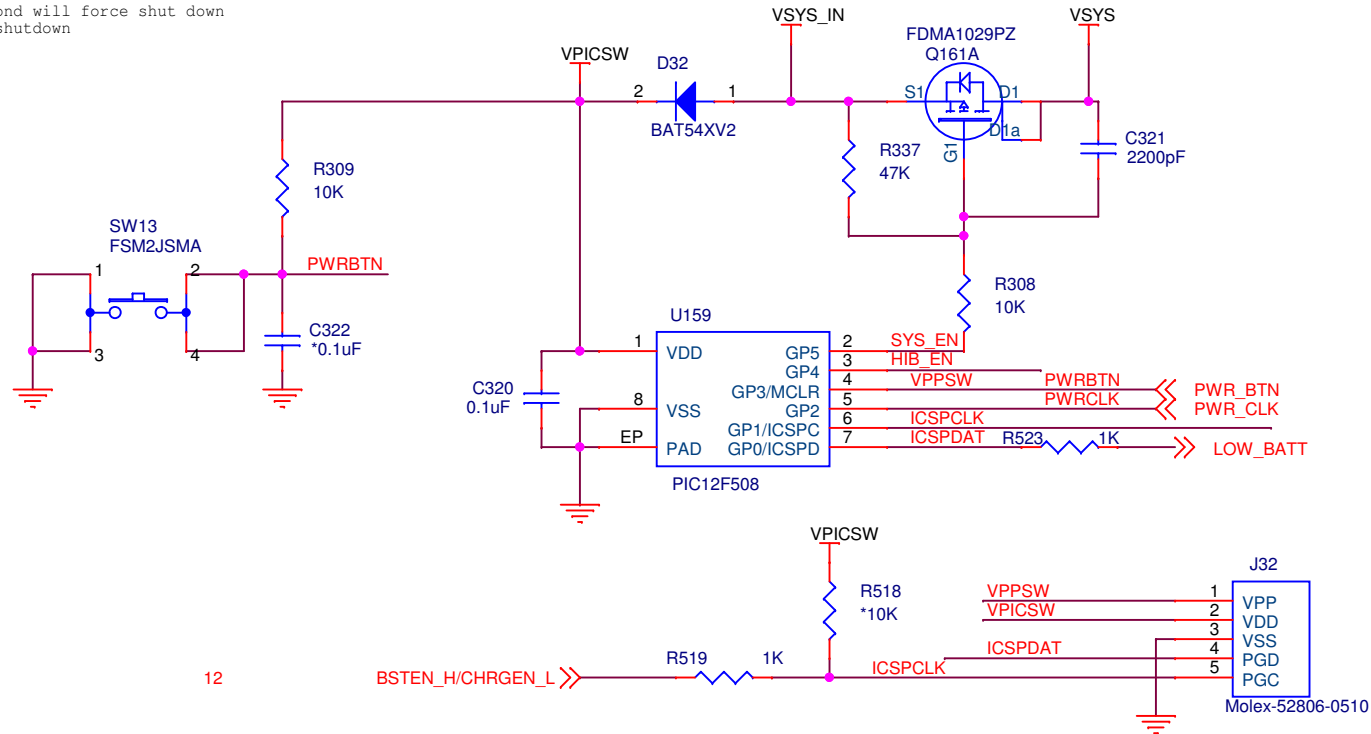

12

USE FFC 21039-0732 @mouser

Power Input

Mod: changed to enable both mini and micro USB power bricks

slikscreen TP18: VSYS_IN

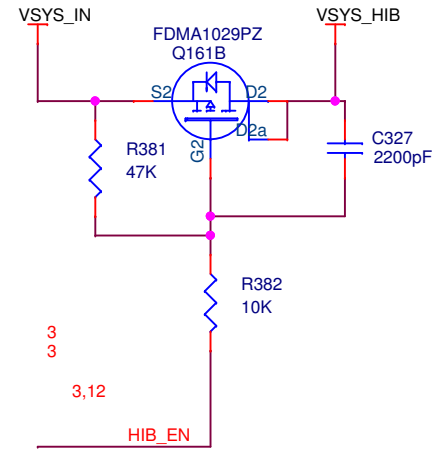

3, 3, 3, 1,2

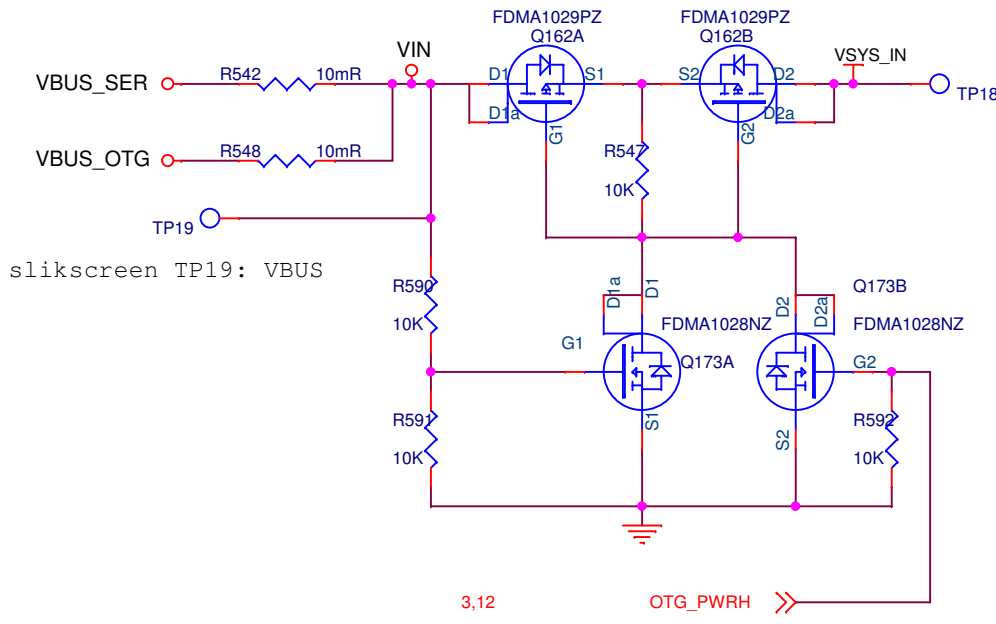

slikscreen TP19: VBUS

3,12

OTG_PWRH

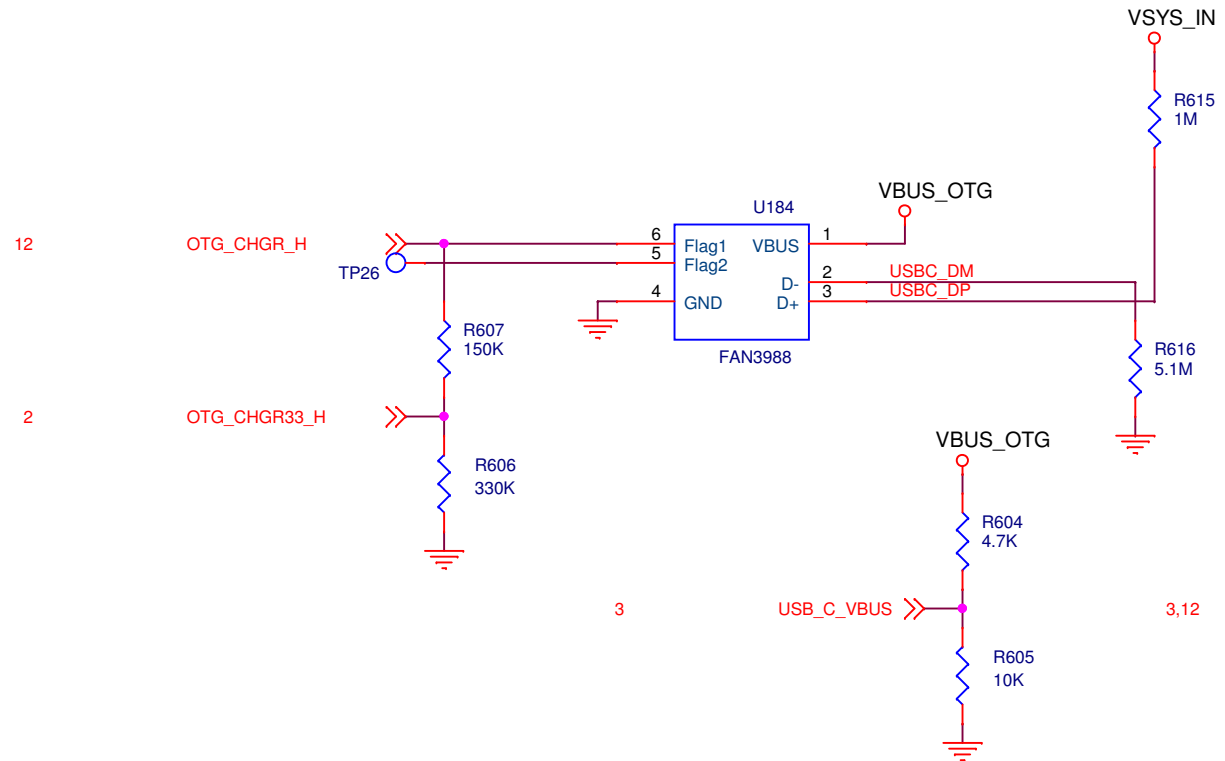

12

2

3

3,12

USB_C_ID

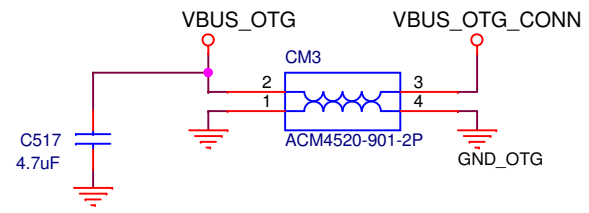

3, 3

USBC_DM

USBC_DP

Silkscreen: USB OTG

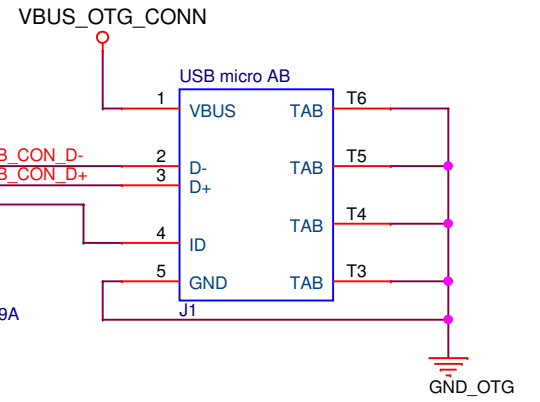

System Power supplies

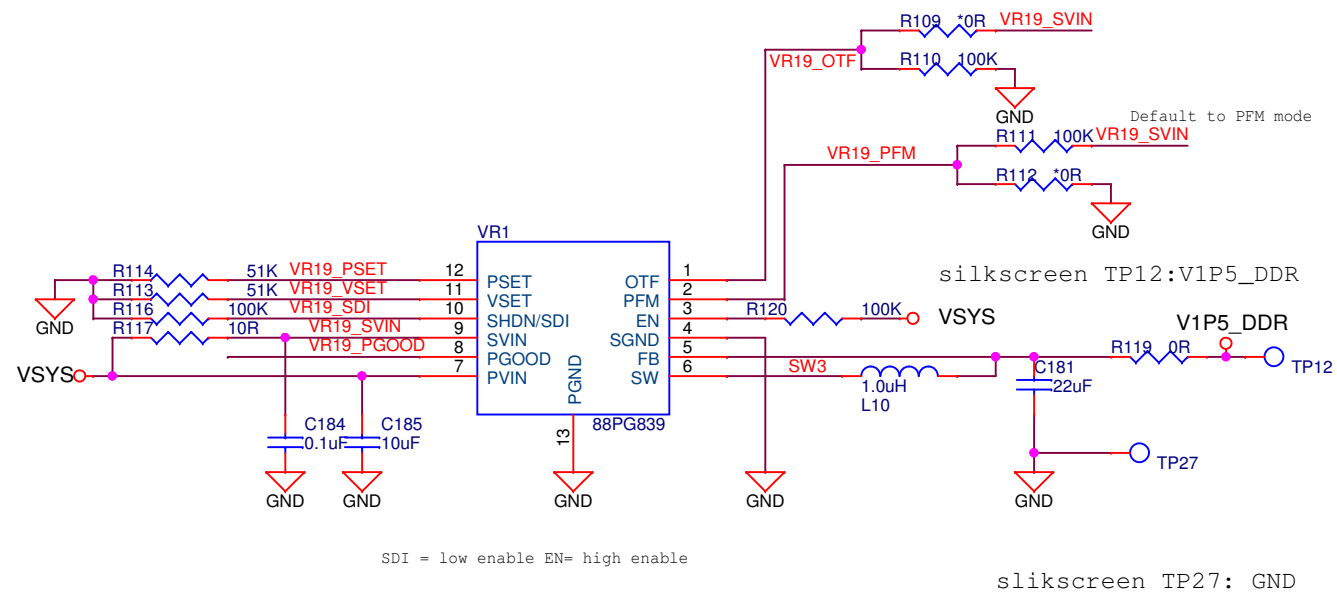

DDR3 1.5V

WIFI & other 1.8V

SYSTEM 3.3V

VCORE 1.0V

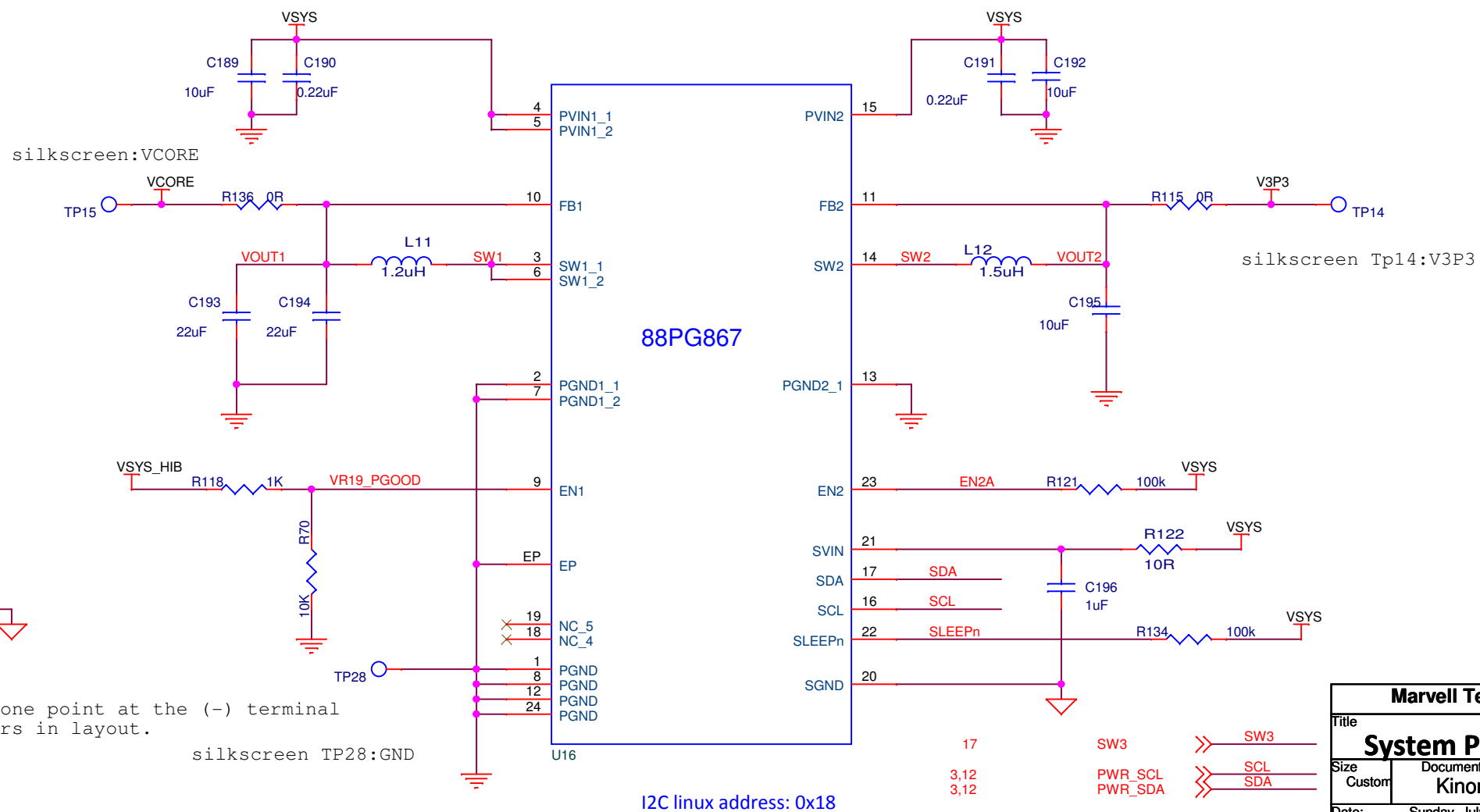

Battery, Charger, Gas Gauge and Boost

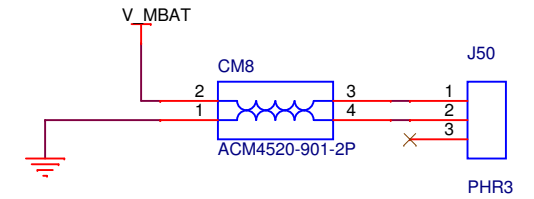

For use with Lithium Ion 18650 batteries

3,10

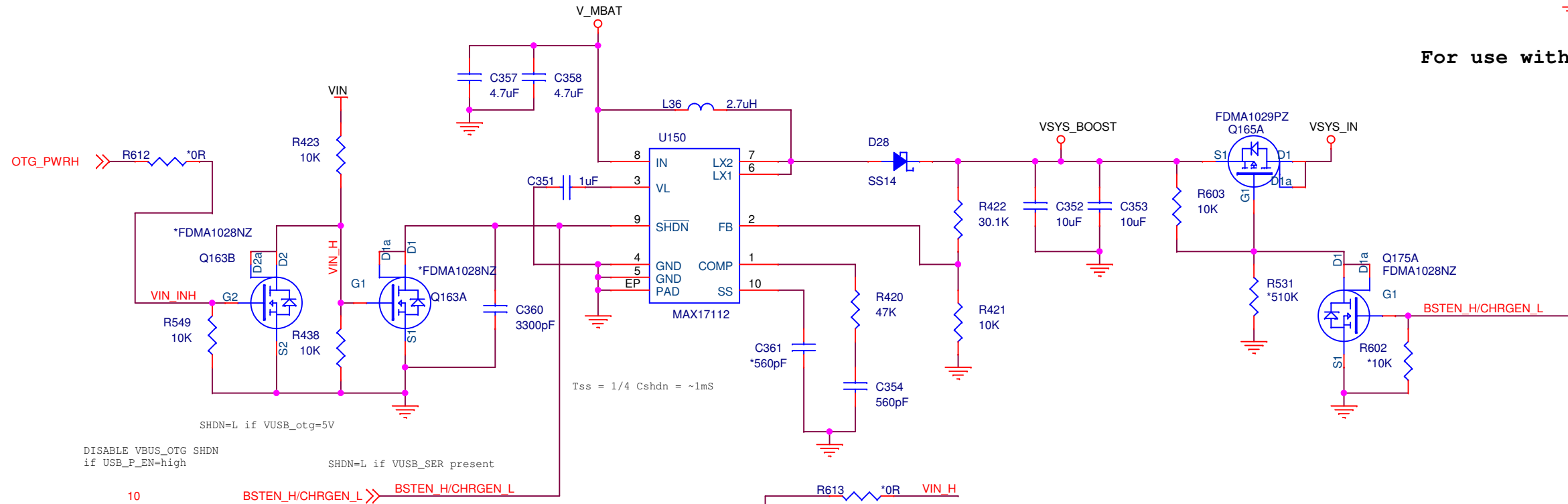

3,10

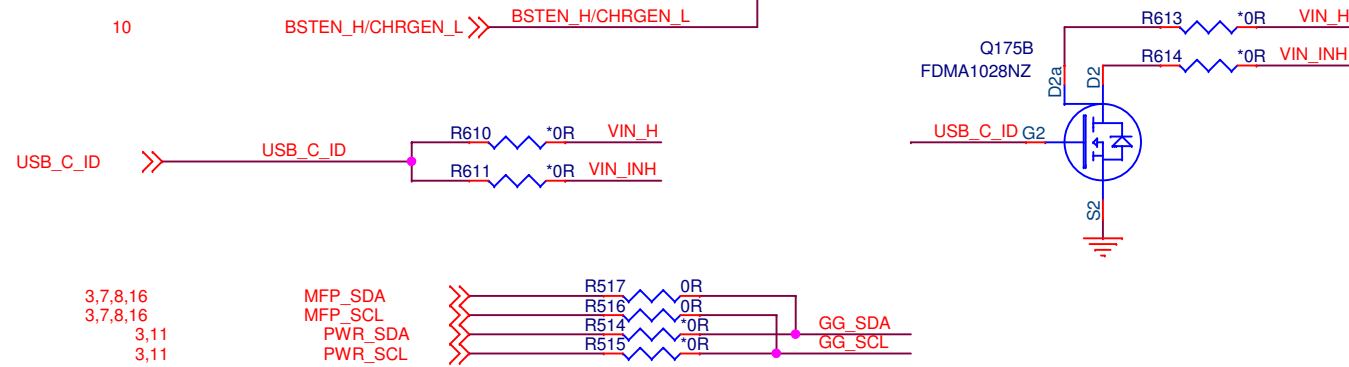

3,10

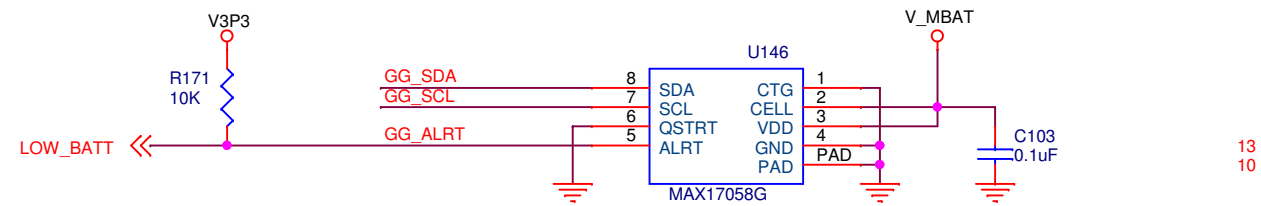

need some driver migration
 ECO x: MAX17058 symbol error fix
 I2C linux address: 0x33

UART CBUS0 - need programming from PC
 Low when connected to Host (disable charger)
 High when connected to Brick

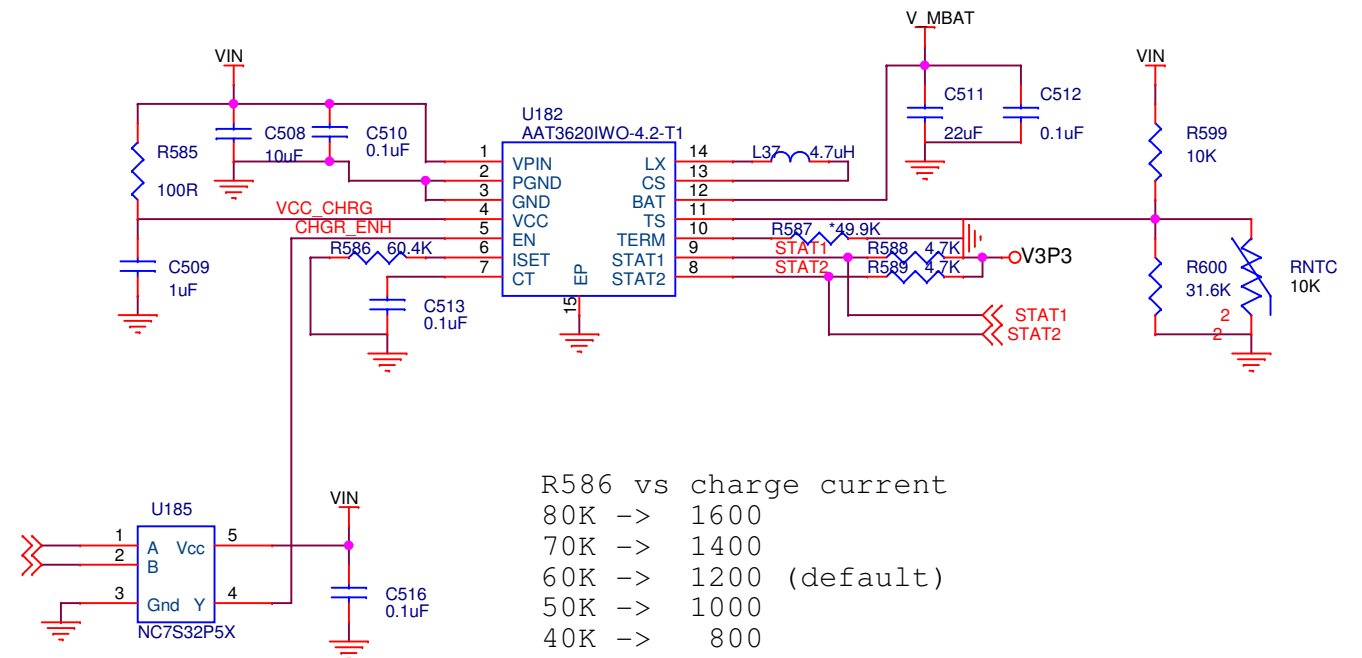

R586 vs charge current
 80K -> 1600
 70K -> 1400
 60K -> 1200 (default)
 50K -> 1000
 40K -> 800
 30K -> 600
 20K -> 400

Debug and console connections

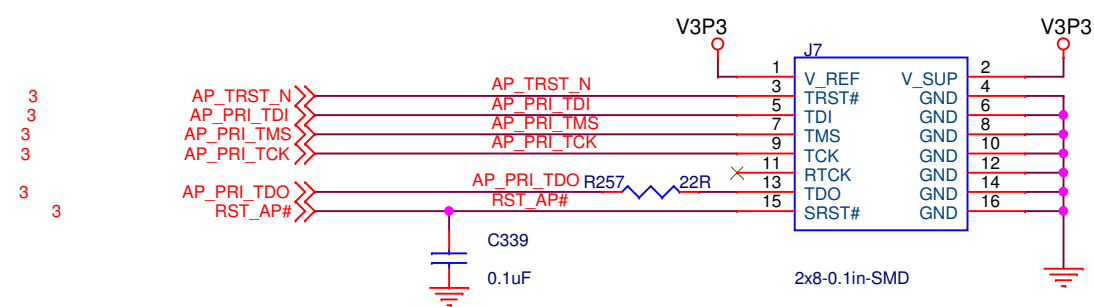
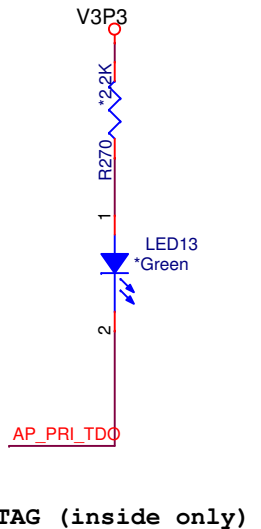
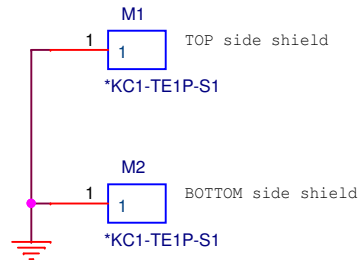
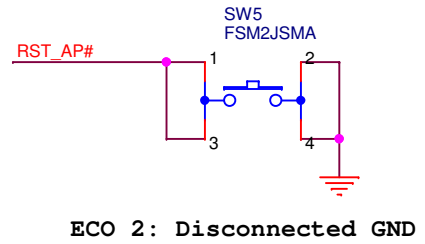
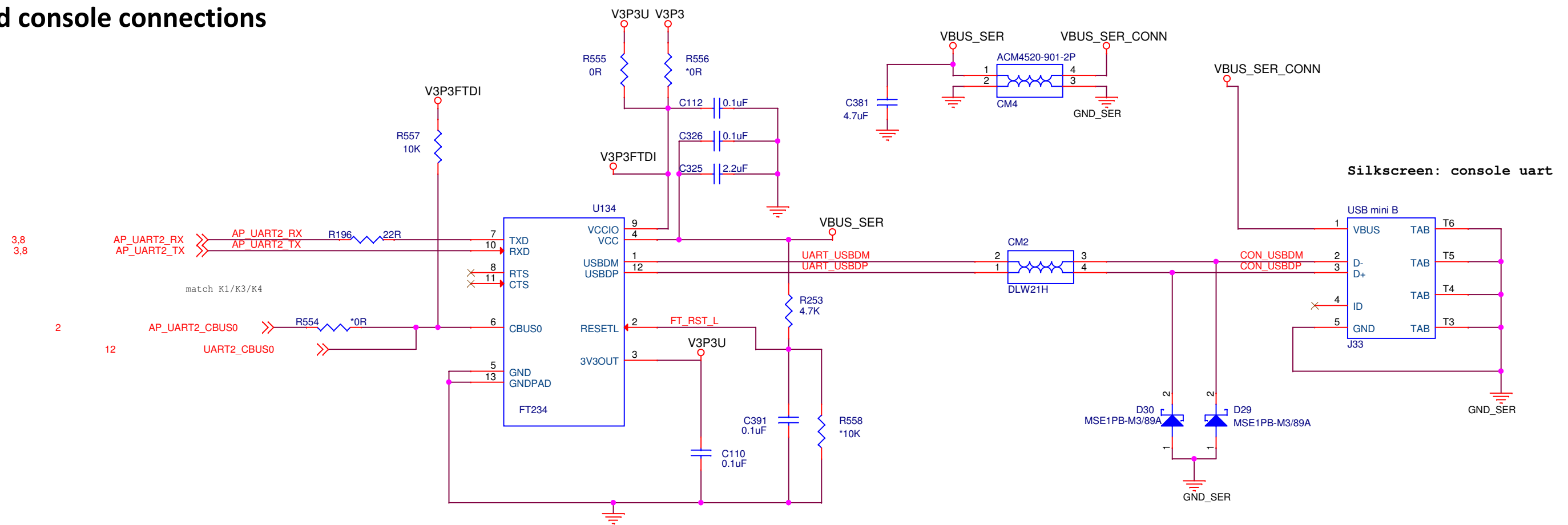

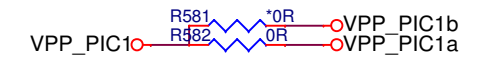
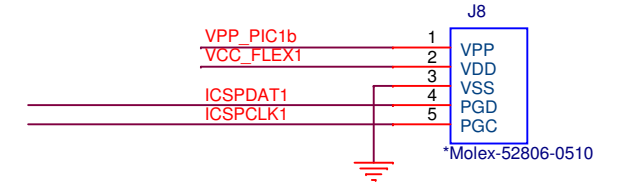
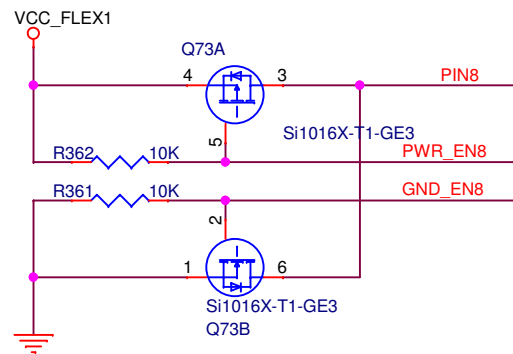
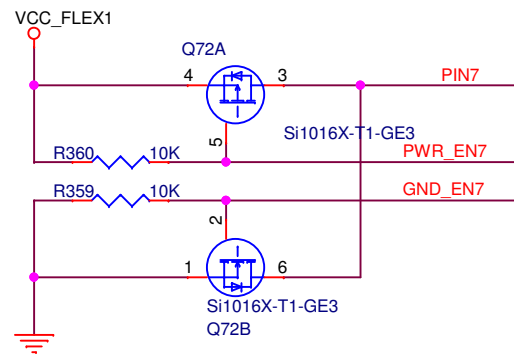
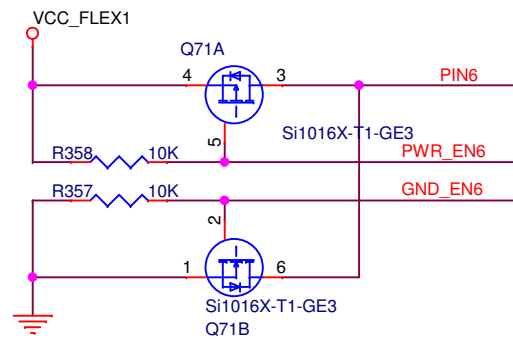
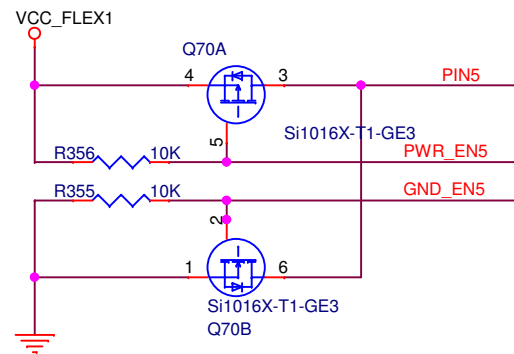
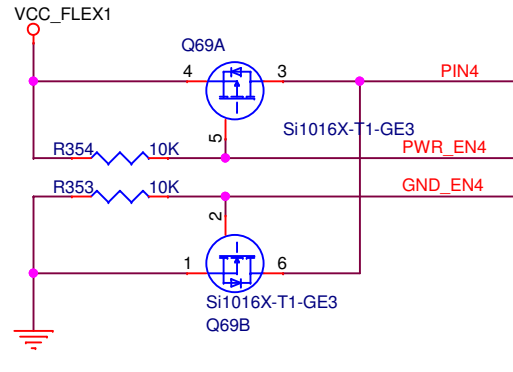
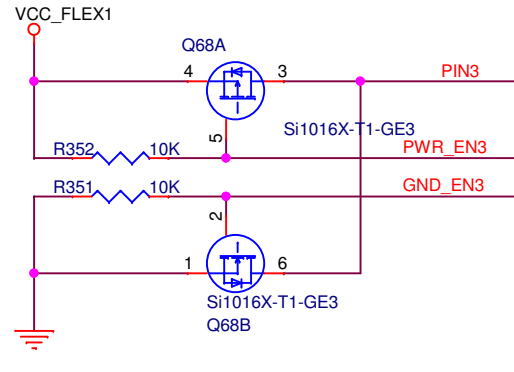
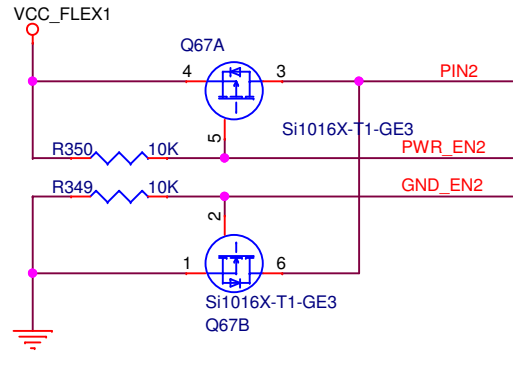
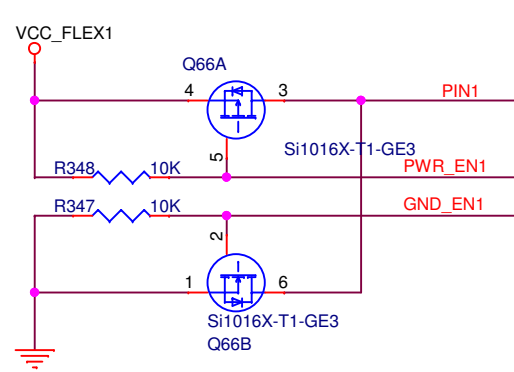

Place close to pin wide trace for V5P0FEXT

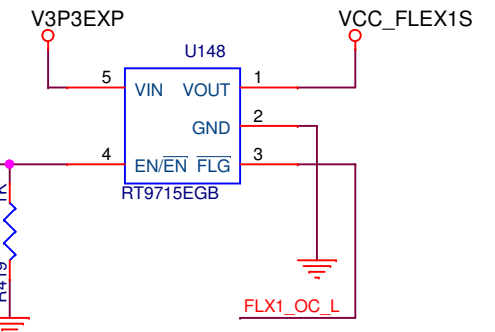
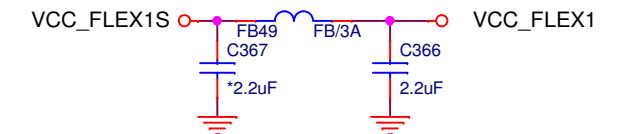

ECO 4: 5V feed to PIC

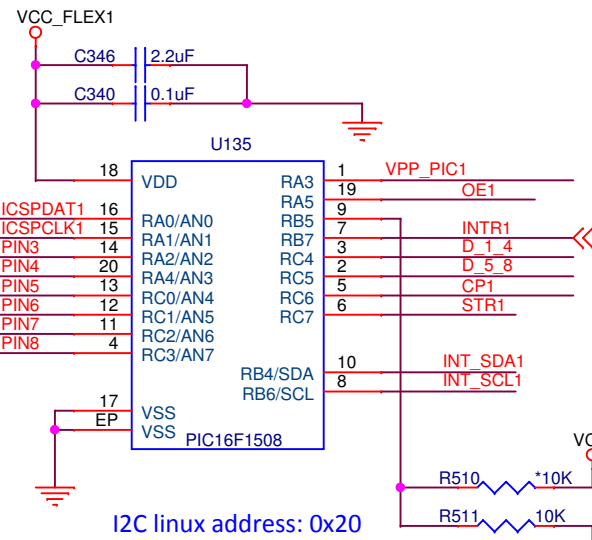
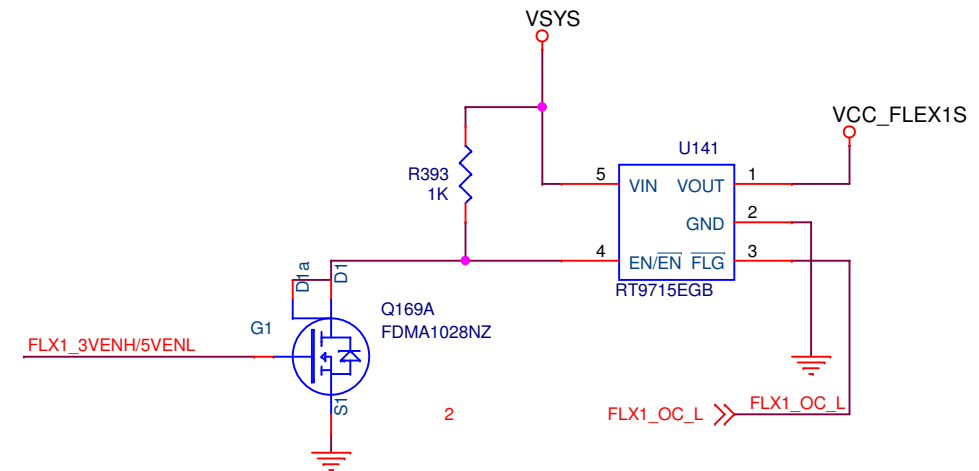

I2C linux address: 0x20

Note: Need location from ID

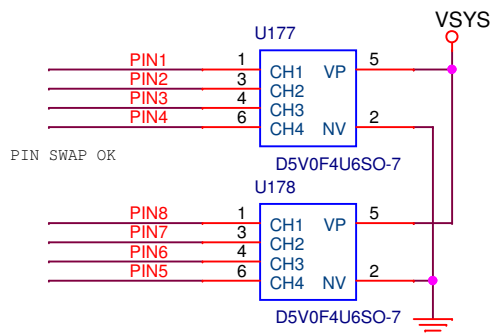
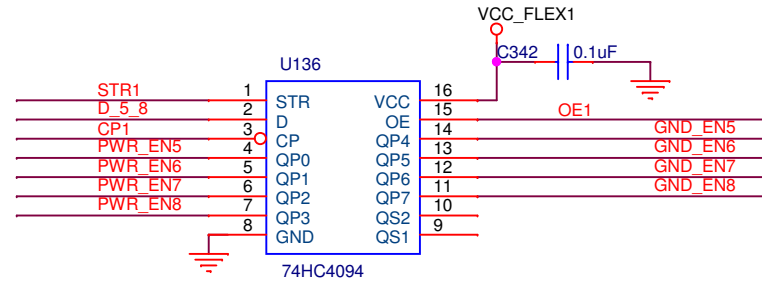
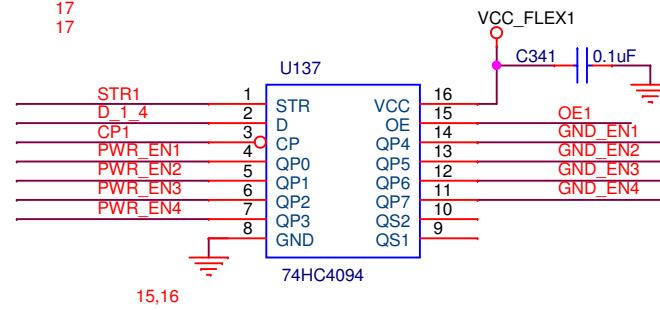

15,16

15,16

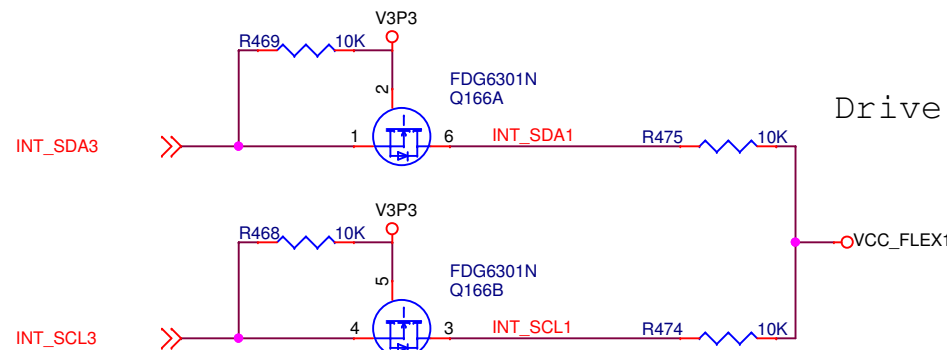

Drive OE low during programming

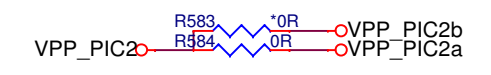
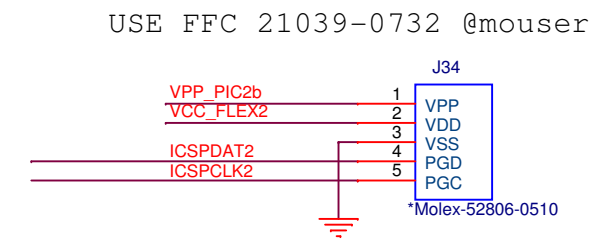
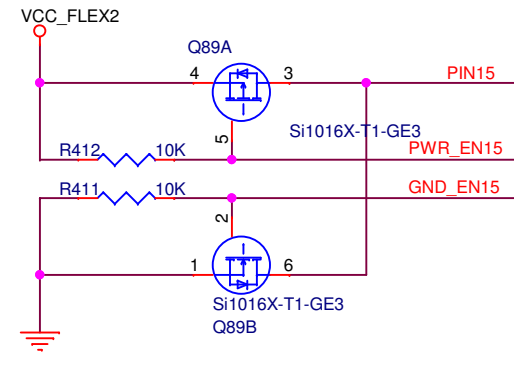
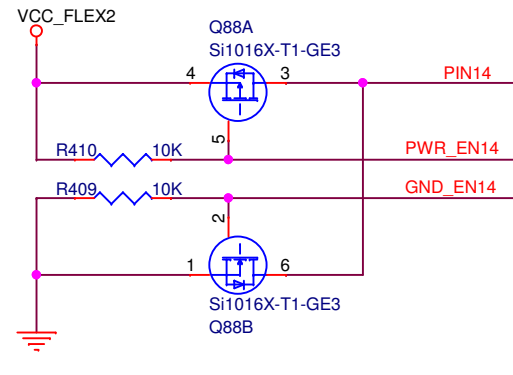
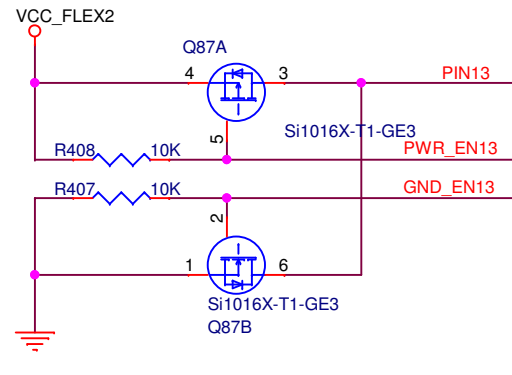
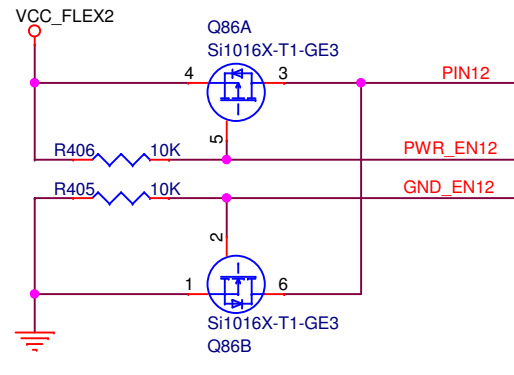
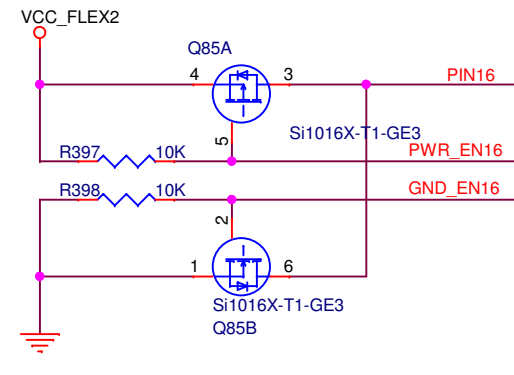
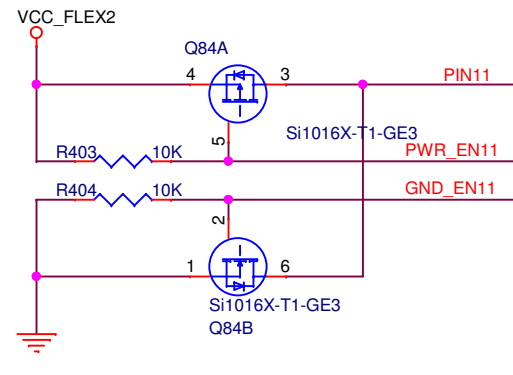
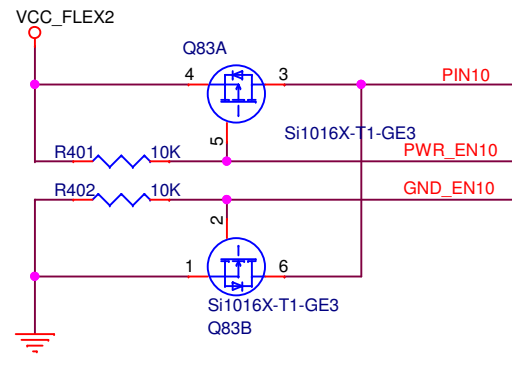
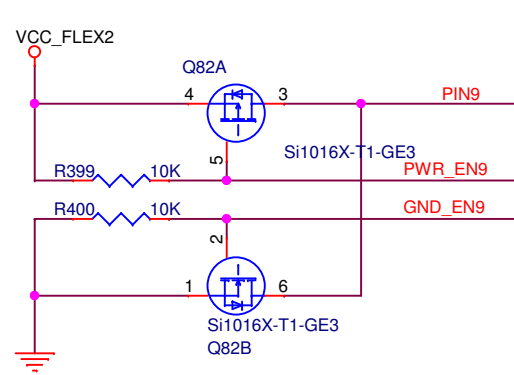

Place close to pin wide trace for V5P0FEXT

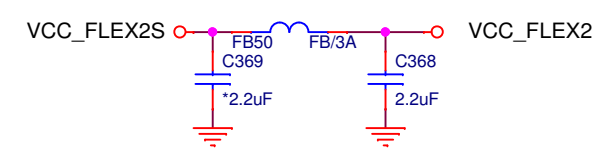

ECO 4: 5V feed to PIC

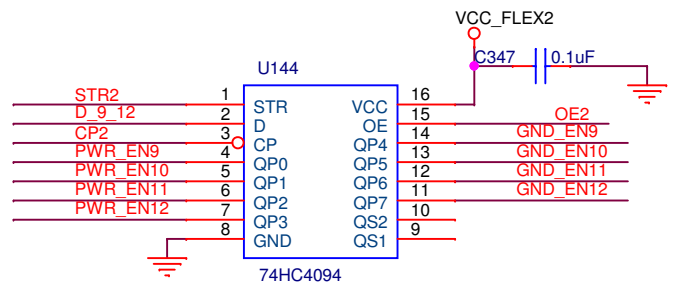
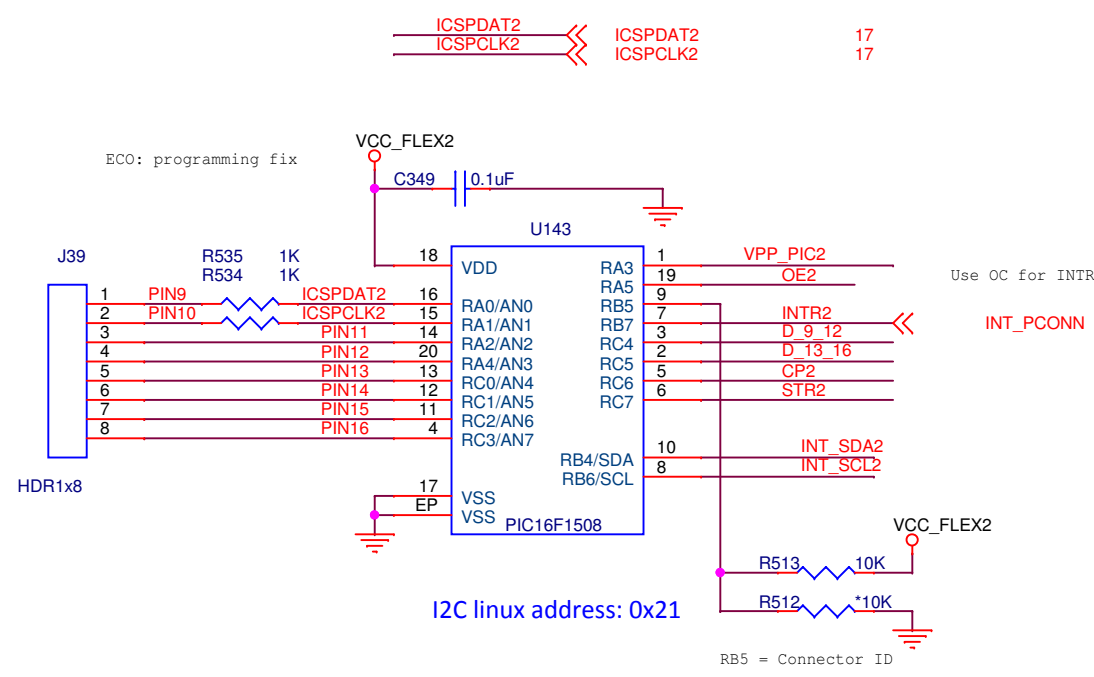
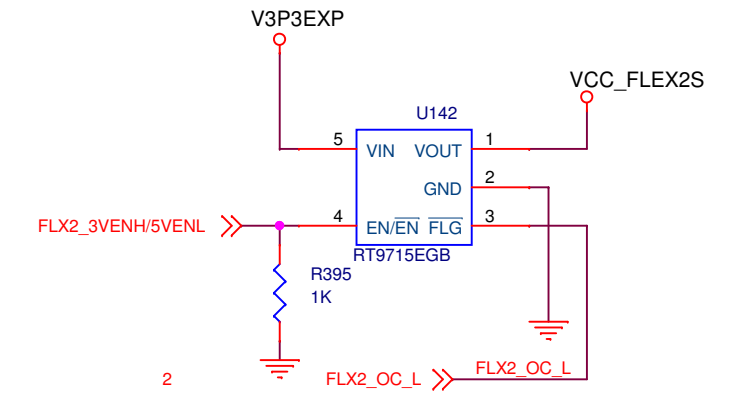
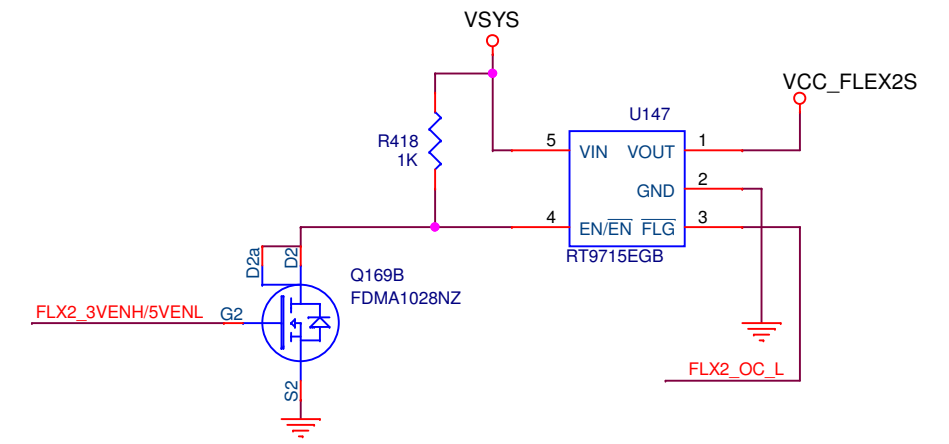

Any case, VCC=5V signal3.3V

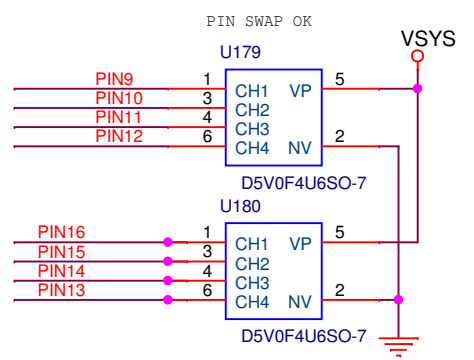
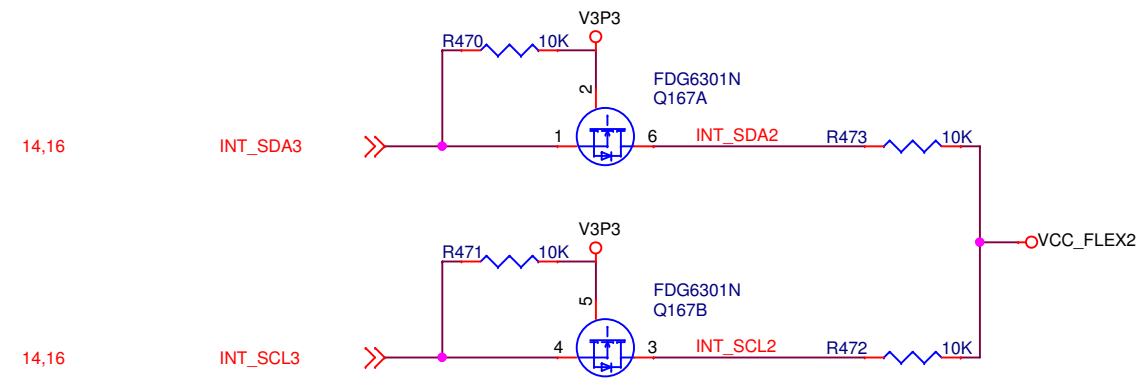
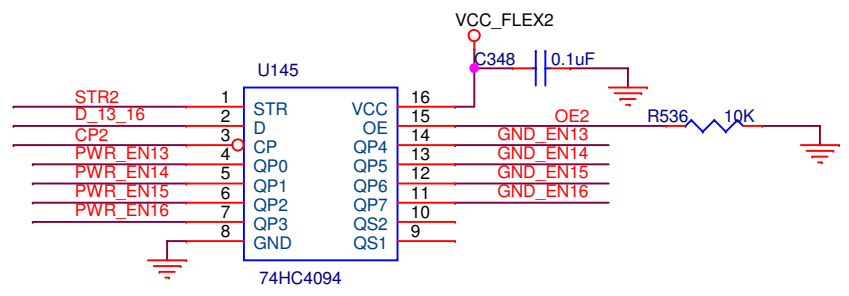

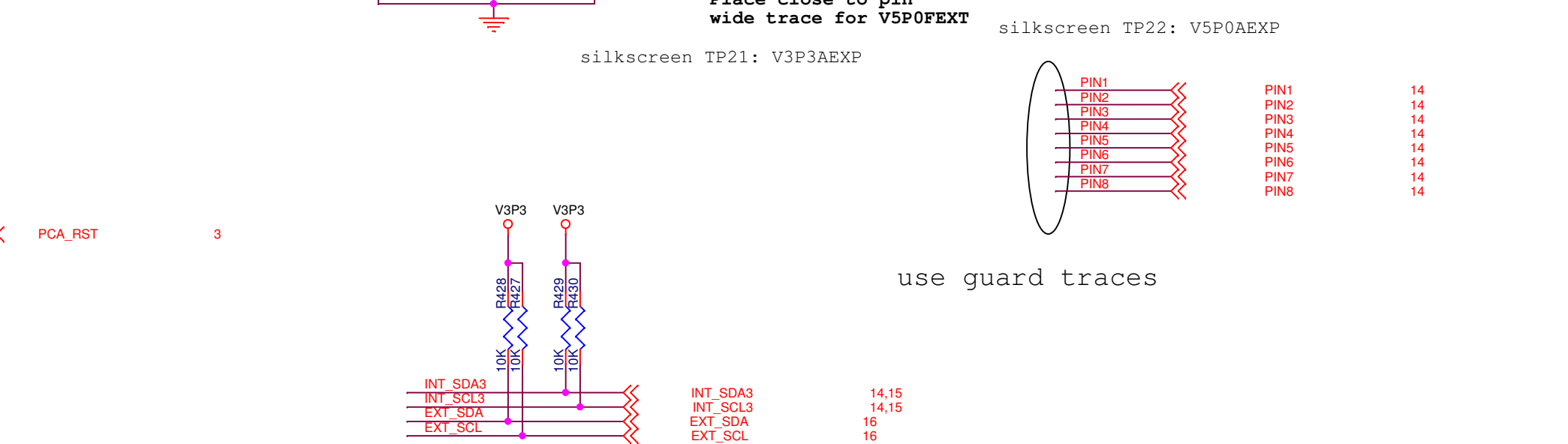
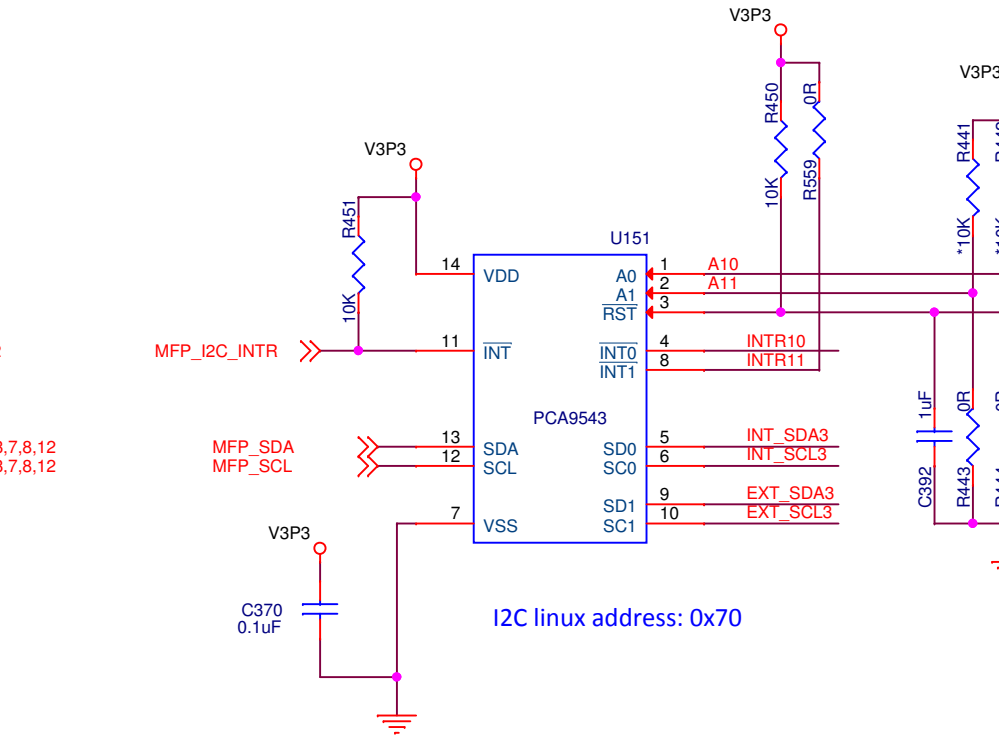
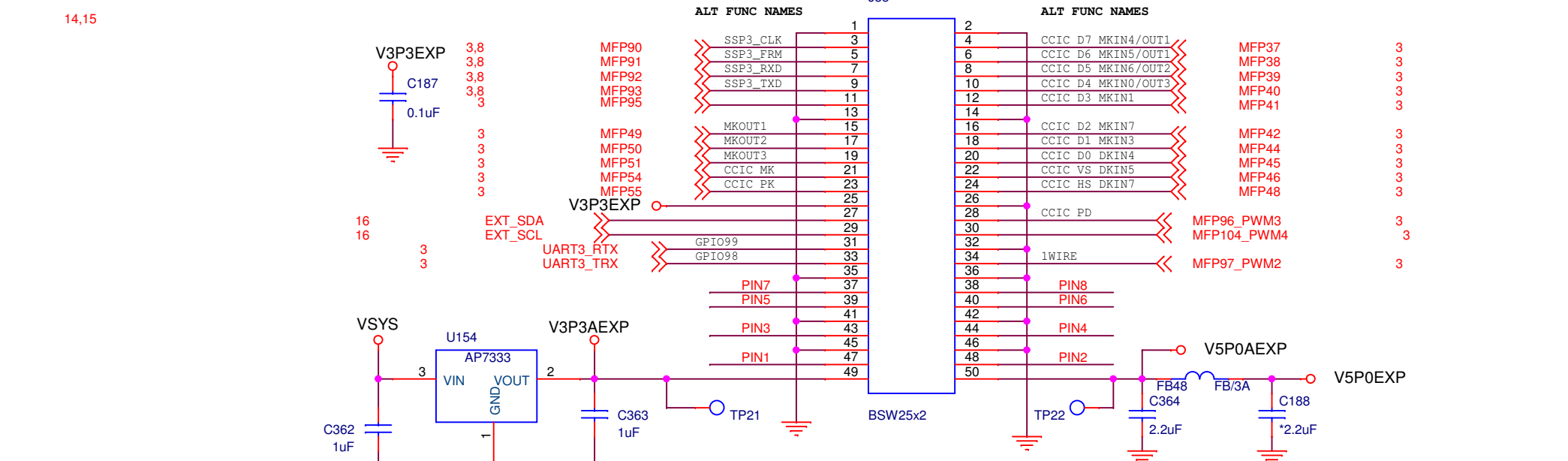
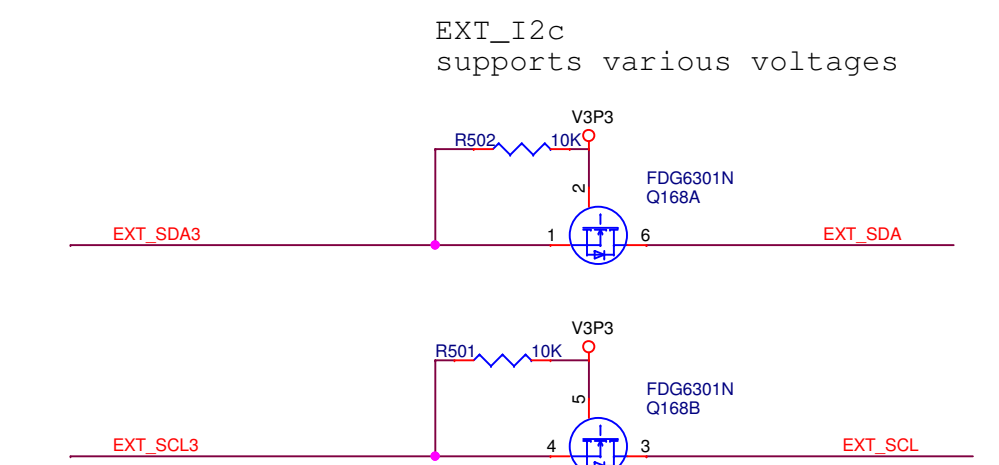
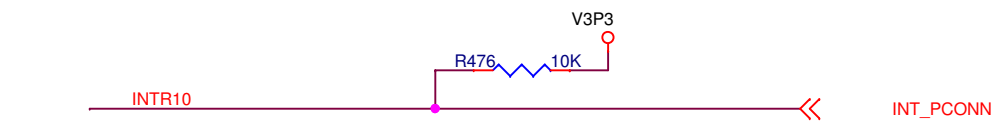
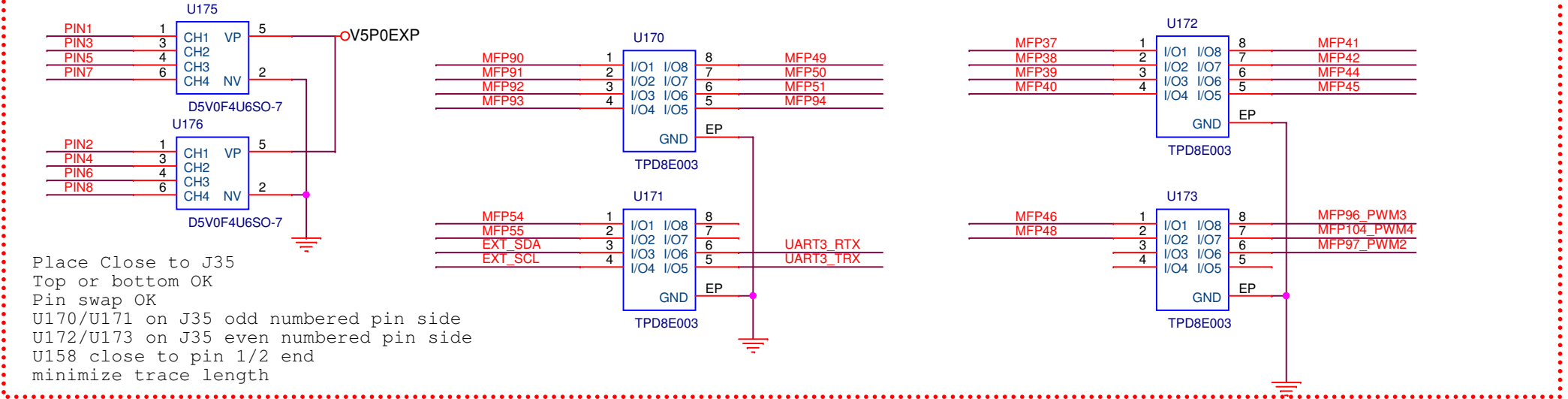
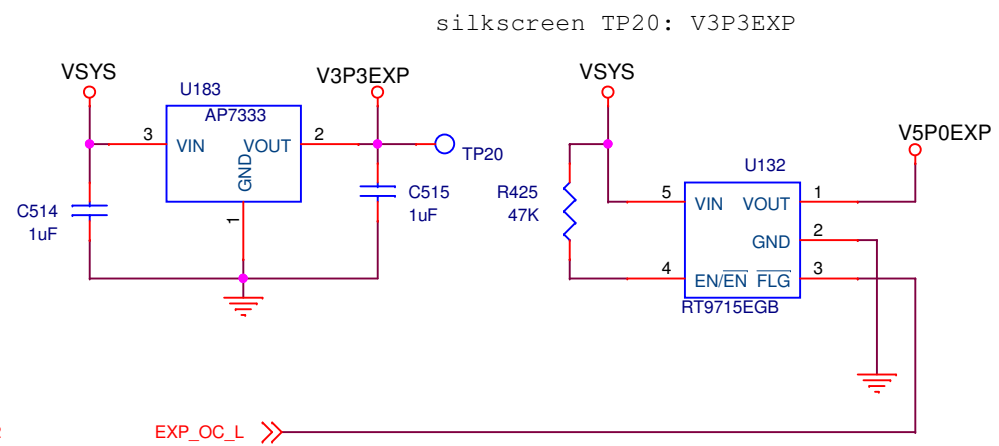

Revised 50 pin, tied to top 8 pins

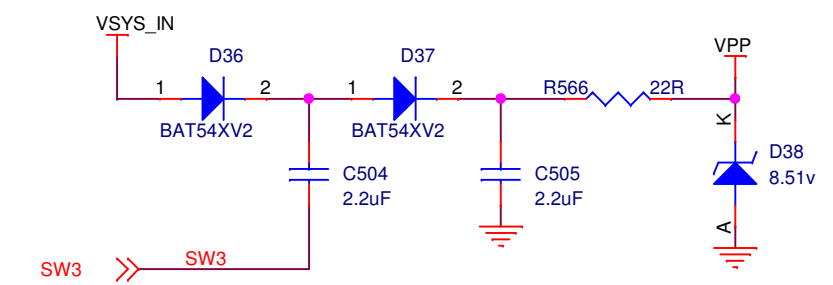
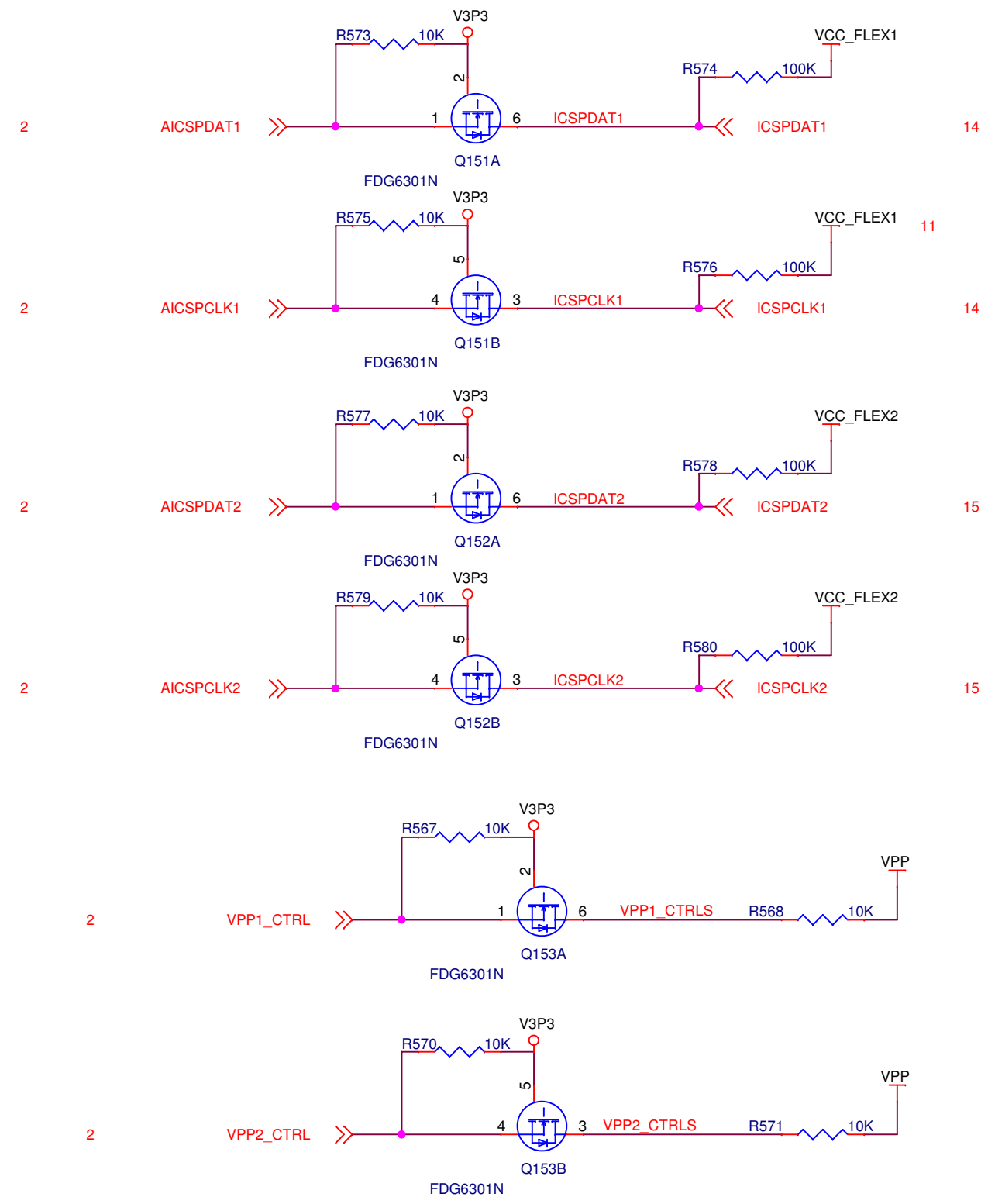

Power for micro controller

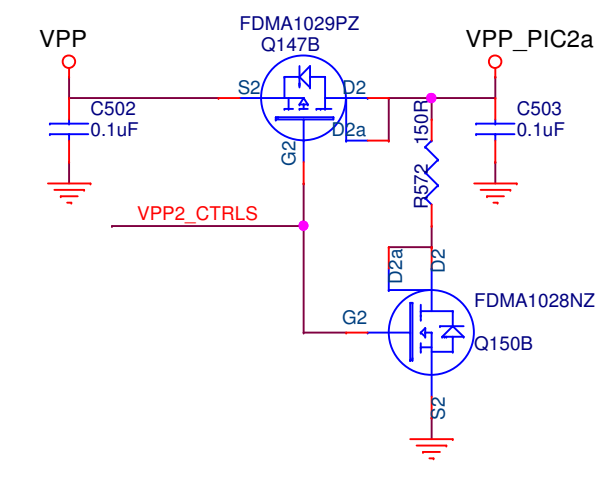
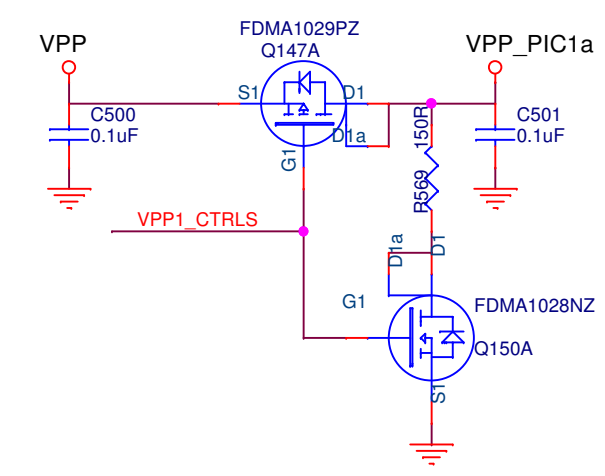

Functional changes from K4R2



- enable hibernate
- enable miniUSB charging
- PIC programmer
- new charger
- USB device power

Circuit changes from K4R3

- P10,P13: added USB power common mode chokes
- P10,P13: populated common mode chokes on USB data
- P14-P16: change i2c mosfets
- P14,P15: rewire programmer connector
- P10: added micro USB pull up for detection
- P12: remove Q163 VIN detection feature due to slow transition to battery

Circuit changes from K4R2

- P01: install Q155 depopulate R336 for hibernate
- P01: added GPIO for PIC programming controls
 - ICSPDAT1 GPIO17
 - ICSPCLK1 GPIO21
 - VPP1_CTRL GPIO3
 - ICSPDAT2 GPIO13
 - ICSPCLK2 GPIO8
 - VPP2_CTRL GPIO2
- P02: signal MFP94 renamed to MFP95
- P03: new mosfets for power sequence
- P06: new values for antenna matching
- P07: CE156 power switch added
- P10: revised power input
 - allow charging from both mini and micro bricks
 - added shutdown control to PIC for low battery cut off to prevent over drain of battery
- P12: U146 MAX17058 Symbol error fix
 - new charger up to 2A switching to speed up charging
 - added cutout switch to boost supply to avoid leak
- P17: PIC programmer VPP supply and signals

Marvell Technology Ltd			
Title	Change Log		
Size	Document Number		Rev
Custom	Kinoma Create		3.0
Date:	Sunday, July 20, 2014	Sheet 18	of 18