

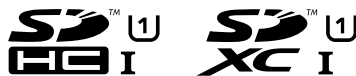

HD MEMORY CARD CAMERA RECORDER

GY-HC900CHU/GY-HC900CHE
GY-HC900STU/GY-HC900RCHE
INSTRUCTIONS (BASIC)

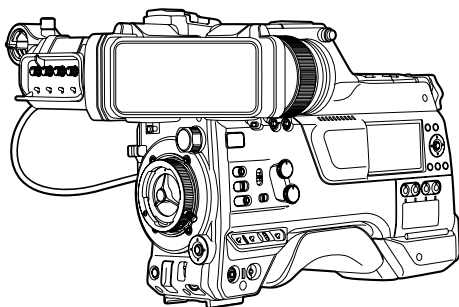

This manual provides a brief explanation on operating this camera recorder. For detailed operation methods and camera settings, please refer to the following Mobile User Guide.

CONNECTED CAM

In this illustration, the supplied viewfinder is attached to the GY-HC900CHU/GY-HC900CHE. Viewfinder is not supplied for GY-HC900STU and GY-HC900RCHE.

The specifications and appearance of this product are subject to changes for further improvement without prior notice.

Please check the latest version of the INSTRUCTIONS from the following Mobile User Guide.

You can also download the PDF from the Mobile User Guide.

Mobile User Guide

When you are outside, you can refer to the instructions from your Android phone or iPhone.

<http://manual3.jvckenwood.com/pro/mobile/global/>

You can view the Mobile User Guide using the browser on your Android phone or iPhone.



For Customer Use:

Enter below the Serial No. which is located on the body.

Retain this information for future reference.

GY-HC900CHU/

Model No. GY-HC900STU

Serial No. _____

Please read the following before getting started:

Thank you for purchasing this product.

Before operating this unit, please read the instructions carefully to ensure the best possible performance.

In this manual, each model number is described without the last letter (U/E) which means the shipping destination.

(U: for USA and Canada, E: for Europe)

Only "U" models (GY-HC900CHU/GY-HC900STU)

have been evaluated by UL.

FOR USA

These are general **IMPORTANT SAFEGUARDS** and certain items may not apply to all appliances.

IMPORTANT SAFEGUARDS

1. Read these instructions.
2. Keep these instructions.
3. Heed all warnings.
4. Follow all instructions.
5. Do not use this apparatus near water.
6. Clean only with dry cloth.
7. Do not block any ventilation openings. Install in accordance with the manufacturer's instructions.
8. Do not install near any heat sources such as radiators, heat registers, stoves, or other apparatus (including amplifiers) that produce heat.
9. Protect the power cord from being walked on or pinched particularly at plugs, convenience receptacles, and the point where they exit from the apparatus.
10. Only use attachments/accessories specified by the manufacturer.
11. Use only with the cart, stand, tripod, bracket, or table specified by the manufacturer, or sold with the apparatus.
When a cart is used, use caution when moving the cart/apparatus combination to avoid injury from tip-over.
12. Unplug this apparatus during lightning storms or when unused for long periods of time.
13. Refer all servicing to qualified service personnel.
Servicing is required when the apparatus has been damaged in any way, such as power-supply cord or plug is damaged, liquid has been spilled or objects have fallen into the apparatus, the apparatus has been exposed to rain or moisture, does not operate normally, or has been dropped.



For USA-California Only

This product contains a CR Coin Cell Lithium Battery which contains Perchlorate Material – special handling may apply.

See www.dtsc.ca.gov/hazardouswaste/perchlorate

POUR LES ÉTATS-UNIS

Ces informations sont des **INFORMATIONS IMPORTANTES RELATIVES À LA SÉCURITÉ** et certains points peuvent ne pas s'appliquer à tous les appareils.

INFORMATIONS IMPORTANTES RELATIVES À LA SÉCURITÉ

1. Lire ces instructions.
2. Conserver ces instructions.
3. Tenir compte de tous les avertissements.
4. Respecter toutes les instructions.
5. Ne pas utiliser cet appareil à proximité de l'eau.
6. Ne nettoyer qu'avec un chiffon sec.
7. Ne pas boucher les ouvertures de ventilation.
Installer selon les instructions du fabricant.
8. Ne pas installer à proximité de sources de chaleur telles que des radiateurs, des accumulateurs de chaleur, des poêles, ou d'autres appareils (comprenant les amplificateurs) qui produisent de la chaleur.
9. Protéger le cordon d'alimentation pour éviter qu'il ne soit piétiné ou ne se coince, tout particulièrement au niveau de la fiche, de la prise de courant et du point où il sort de l'appareil.
10. Utiliser uniquement des équipements/accessoires spécifiés par le fabricant.
11. N'utiliser qu'avec le chariot, le stand, le trépied, le support ou la table spécifié par le fabricant, ou vendu avec l'appareil.
Lorsqu'un chariot est utilisé, faire attention pour déplacer la combinaison chariot/appareil pour éviter des blessures causées par un basculement.
12. Débrancher cet appareil pendant un orage ou quand il n'est pas utilisé pendant une longue durée.
13. L'entretien ou la réparation de l'appareil doit être effectué par du personnel qualifié uniquement.
Un dépannage est nécessaire lorsque l'appareil a été endommagé d'une façon ou d'une autre, telle que lorsque le cordon d'alimentation ou la fiche est endommagé, si du liquide a été renversé ou si des objets sont tombés à l'intérieur de l'appareil, si l'appareil a été exposé à la pluie ou à l'humidité, ne fonctionne pas normalement ou a fait une chute.



Pour Californie des États-Unis seulement

Cet appareil contient une pile-bouton CR au lithium qui contient du perchlorate – une manipulation spéciale peut être requise.

Voir www.dtsc.ca.gov/hazardouswaste/perchlorate

Safety Precautions

FOR USA AND CANADA



CAUTION

RISK OF ELECTRIC SHOCK
DO NOT OPEN



CAUTION:
TO REDUCE THE RISK OF ELECTRIC SHOCK, DO NOT REMOVE COVER (OR BACK). NO USER-SERVICEABLE PARTS INSIDE. REFER SERVICING TO QUALIFIED SERVICE PERSONNEL.



The lightning flash with arrowhead symbol, within an equilateral triangle is intended to alert the user to the presence of uninsulated “dangerous voltage” within the product’s enclosure that may be of sufficient magnitude to constitute a risk of electric shock to persons.



The exclamation point within an equilateral triangle is intended to alert the user to the presence of important operating and maintenance (servicing) instructions in the literature accompanying the appliance.

POUR CANADA



ATTENTION

RISQUE D'ELECTROCUTION
NE PAS OUVRIR



ATTENTION:
POUR EVITER TOUT RISQUE D'ELECTROCUTION NE PAS OUVRIR LE BOITIER. AUCUNE PIECE INTERIEURE N'EST A REGLER PAR L'UTILISATEUR. SE REFERER A UN AGENT QUALIFIE EN CAS DE PROBLEME.



Le symbole de l'éclair à l'intérieur d'un triangle équilatéral est destiné à alerter l'utilisateur sur la présence d'une “tension dangereuse” non isolée dans le boîtier du produit. Cette tension est suffisante pour provoquer l'électrocution de personnes.



Le point d'exclamation à l'intérieur d'un triangle équilatéral est destiné à alerter l'utilisateur sur la présence d'opérations d'entretien importantes au sujet desquelles des renseignements se trouvent dans le manuel d'instructions.

Ces symboles ne sont utilisés qu'aux Etats-Unis.

Supplier's Declaration of Conformity

Model Number: GY-HC900CHU
GY-HC900STU
Trade Name: JVC
Responsible party: JVCCKENWOOD USA Corporation
Address: 500 Valley Road,
Suite 203 Wayne,
NJ 07470
Telephone Number: 973-317-5000

This device complies with Part 15 of FCC Rules. Operation is subject to the following two conditions: (1) This device may not cause harmful interference, and (2) this device must accept any interference received, including interference that may cause undesired operation.

Déclaration de conformité du fournisseur

Numéro de modèle : GY-HC900CHU
GY-HC900STU
Nom de marque : JVC
Personne responsable : JVCCKENWOOD USA Corporation
Adresse : 500 Valley Road,
Suite 203 Wayne,
NJ 07470
Numéro de téléphone : 973-317-5000

Cet ensemble se conforme à la partie 15 des règles de la FCC (Federal Communications Commission). Le fonctionnement est sujet aux deux conditions suivantes : (1) Cet appareil ne peut pas causer d'interférences nuisibles, et (2) cet appareil doit accepter toute interférence reçue, comprenant des interférences qui peuvent causer un mauvais fonctionnement.

Changes or modifications not approved by JVC could void the user's authority to operate the equipment. This equipment has been tested and found to comply with the limits for a Class A digital device, pursuant to Part 15 of the FCC Rules. These limits are designed to provide reasonable protection against harmful interference when the equipment is operated in a commercial environment.

This equipment generates, uses, and can radiate radio frequency energy and, if not installed and used in accordance with the instructions, may cause harmful interference to radio communications. Operation of this equipment in a residential area is likely to cause harmful interference in which case the user will be required to correct the interference at his own expense.

Des changements ou modifications non approuvés par JVC peuvent annuler le droit de l'utilisateur de faire fonctionner l'appareil. Cet appareil a été testé et il a été reconnu qu'il se conforme aux limites concernant l'appareillage informatique de classe A correspondant à la partie 15 des règles de la FCC. Ces limites sont conçues pour fournir une protection raisonnable contre les interférences dangereuses lorsque l'équipement est utilisé dans un environnement commercial.

Cet appareil génère, utilise et peut émettre de l'énergie des fréquences radio et, s'il n'est pas installé et utilisé selon les instructions du fabricant, peut causer des interférences nuisibles en communications radio. L'utilisation de cet équipement dans une zone résidentielle est susceptible de causer des interférences néfastes, auquel cas l'utilisateur devra prendre des mesures à ses propres frais.

CAUTION:

The mains plug shall remain readily operable.

- Remove the mains plug immediately if the camera functions abnormally.

WARNING:

The battery pack, the camera with battery installed, and the remote control with battery installed should not be exposed to excessive heat such as direct sunlight, fire or the like.

WARNING: TO PREVENT FIRE OR SHOCK HAZARD, DO NOT EXPOSE THIS UNIT TO RAIN OR MOISTURE.

NOTES:

- The rating plate and safety caution are on the bottom and/or the back of the main unit.
- The serial number plate is on the bottom of the unit.

Caution on Replaceable lithium battery

The battery used in this device may present a fire or chemical burn hazard if mistreated.

Do not recharge, disassemble, heat above 100°C (212°F) or incinerate.

Replace battery with Panasonic, Sanyo, Sony or Maxell CR2025.

Danger of explosion or risk of fire if the battery is incorrectly replaced.

- Dispose of used battery promptly.
- Keep away from children.
- Do not disassemble and do not dispose of in fire.

Attention:

La prise secteur doit être opérationnelle.

- Débranchez immédiatement la fiche secteur si le caméscope ne fonctionne pas normalement.

Avertissement:

Évitez d'exposer la batterie, le caméscope avec la batterie insérée ou la télécommande avec la batterie insérée à une chaleur excessive, telle que celle des rayons directs du soleil, d'un feu ou de tout autre source de chaleur.

AVERTISSEMENT : POUR EVITER LES RISQUES D'INCENDIE OU D'ELECTROCUTION, NE PAS EXPOSER L'APPAREIL A LA PLUIE NI A L'HUMIDITE.

REMARQUES :

- La plaque d'identification et l'avertissement de sécurité se trouvent sous l'appareil et/ou au dos.
- La plaque du numéro de série est située sur la partie inférieure de l'appareil.

Avertissement sur la pile au lithium remplaçable

La pile utilisée dans cet appareil peut présenter des risques d'incendie ou de brûlure chimique si elle est mal traitée.

Ne pas recharger, démonter, chauffer à plus de 100°C (212°F) ni mettre au feu.

Remplacez la pile avec Panasonic, Sanyo, Sony ou Maxell CR2025.

Danger d'explosion ou risque d'incendie si la pile n'est pas changée correctement.

- Jeter immédiatement les piles usées.
- Placer hors de la portée des enfants.
- Ne pas démonter ni jeter au feu.

When the equipment is installed in a cabinet or on a shelf, make sure that it has sufficient space on all sides to allow for ventilation (10 cm (3-15/16") or more on both sides, on top and at the rear). Do not block the ventilation holes. (If the ventilation holes are blocked by a newspaper, or cloth etc. the heat may not be able to get out.) No naked flame sources, such as lighted candles, should be placed on the apparatus. When discarding batteries, environmental problems must be considered and the local rules or laws governing the disposal of these batteries must be followed strictly.

The apparatus shall not be exposed to dripping or splashing and that no objects filled with liquids, such as vases, shall be placed on the apparatus.

Do not point the lens directly into the sun. This can cause eye injuries, as well as lead to the malfunctioning of internal circuitry. There is also a risk of fire or electric shock.

CAUTION!

The following notes concern possible physical damage to this unit and to the user.

Carrying or holding this unit by the LCD monitor can result in dropping the unit, or in a malfunction.

Do not use a tripod on unsteady or unlevel surfaces. It could tip over, causing serious damage to the unit.

CAUTION!

Connecting cables (Audio/Video, etc.) to this unit and leaving it on top of the TV is not recommended, as tripping on the cables will cause the unit to fall, resulting in damage.

Si le matériel est installé dans un coffret ou sur une étagère, s'assurer qu'il y a un espace suffisant sur tous les côtés pour permettre la ventilation (10 cm (3-15/16") ou plus sur les deux côtés, au dessus et à l'arrière).

Ne pas boucher les orifices de ventilation.

(Si les orifices de ventilation sont bouchés par un journal, un tissu, etc., la chaleur peut ne pas s'éliminer.)

Aucune source à flamme nue, telle que des bougies allumées, ne doit être placée sur l'appareil.

En jetant des batteries aux ordures, les problèmes d'environnement doivent être pris en considération et les réglementations locales ou la législation concernant le rebut de ces batteries doivent être strictement respectées.

L'appareil ne doit pas être exposé à de l'eau ou à des éclaboussures et les objets remplis de liquide, tels que des vases, ne doivent pas être placés sur l'appareil.

Ne dirigez pas l'objectif directement vers le soleil. Vous pourriez vous abîmer la vue et l'appareil pourrait être endommagé. Il y a aussi risque d'incendie ou d'électrocution.

Attention!

Les remarques suivantes sont destinées à protéger l'utilisateur et le caméscope contre des dommages éventuels.

Ne pas transporter ou saisir le caméscope par l'écran LCD, car il pourrait tomber ou s'endommager.

Ne pas utiliser de trépied photographique sur des surfaces irrégulières et inclinées. Il pourrait tomber et le caméscope pourrait être sérieusement endommagé.

Attention!

Avec des câbles (Audio/Vidéo, etc.) raccordés, il est recommandé de ne pas laisser le caméscope sur le dessus du téléviseur, car tirer sur les câbles pourrait faire tomber le caméscope, causant des dommages.

For GY-HC900RCHE**IMPORTANT (for owners in the U.K.)
Connection to the mains supply in
the United Kingdom.****DO NOT cut off the mains plug from
this equipment.**

If the plug fitted is not suitable for the power points in your home or the cable is too short to reach a power point, then obtain an appropriate safety approved extension lead or contact the local dealers in your area.

BE SURE to replace the fuse only with an identical approved type, as originally fitted, and to replace the fuse cover.

If nonetheless the mains plug is cut off be sure to remove the fuse and dispose of the plug immediately, to avoid possible shock hazard by inadvertent connection to the mains supply.

If this product is not supplied fitted with a mains plug then follow the instructions given below:

DO NOT make any connection to the Larger Terminal coded E or Green.

The wires in the mains lead are coloured in accordance with the following code:

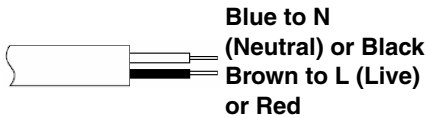

If these colours do not correspond with the terminal identifications of your plug, connect as follows:

Blue wire to terminal coded N (Neutral) or coloured black.

Brown wire to terminal coded L (Live) or coloured Red.

If in doubt — consult a competent electrician.

WARNING

Operation of this equipment in a residential environment could cause radio interference.

CAUTION:

Where there are strong electromagnetic waves or magnetism, for example near a radio or TV transmitter, transformer, motor, etc., the picture and the sound may be disturbed. In such case, please keep the apparatus away from the sources of the disturbance.

The plastics packaging bags may cause suffocation when they are covered over the head. Tear them open, and keep them away from the reach of infants and children by ensuring that they are disposed of properly.

CAUTIONS:

To prevent shock, do not open the cabinet.
No user serviceable parts inside.
Refer servicing to qualified personnel.

CHE RCHE

The European representative of
JVC KENWOOD Corporation is:

Die europäische Vertretung für die
JVC KENWOOD Corporation ist:

JVCKENWOOD Deutschland GmbH
Konrad-Adenauer-Allee 1-11
61118 Bad Vilbel
GERMANY

RCHE

Dear customer,
this apparatus is in compliance with the
valid European Directive and the
relevant standards regarding
electromagnetic compatibility.

Sehr geehrter Kunde, sehr geehrte
Kundin,
dieses Gerät stimmt mit der gültigen
europäischen Richtlinie und den
relevanten Normen bezüglich
elektromagnetischer Verträglichkeit
überein.

CHE

Hereby, JVC KENWOOD Corporation
declares that the radio equipment type
GY-HC900CHE is in compliance with
Directive 2014/53/EU.

The full text of the EU declaration of
conformity is available at the following
internet address:

Hiermit erklärt die , JVC KENWOOD
Corporation, dass der Funkanlagentyp
GY-HC900CHE der Richtlinie
2014/53/EU entspricht.
Der vollständige Text der
EU-Konformitätserklärung ist unter der
folgenden Internetadresse verfügbar:

CE

<http://www3.jvckenwood.com/ecdoc/>

■ Para Brasil

Informação sobre eliminação de baterias

Este produto não deverá ser eliminado
como lixo doméstico em geral.
Devolva a bateria velha ao comerciante
ou para a rede autorizada, para que seja
devolvida ao fabricante ou importador.
A reciclagem e eliminação de lixo em
uma maneira adequada, ajudarão para
preservar recursos, prevenindo, ao
mesmo tempo, contra efeitos prejudiciais
sobre a nossa saúde e o meio ambiente.

Importer (EU only)

JVCKENWOOD U.K. Limited
12 Priestley Way, London NW2 7BA,
UNITED KINGDOM

Importeur (Nur EU)

JVCKENWOOD Deutschland GmbH
Konrad-Adenauer-Allee 1-11, 61118 Bad Vilbel,
DEUTSCHLAND

Importatore (Solo EU)

JVCKENWOOD Italia S.p.A.
Via G. Sirtori 7/9, 20129 Milano, ITALIA

Importeur (Alleen EU)

JVCKENWOOD Belgium N.V.
Leuvensesteenweg 248J, 1800 Vilvoorde,
BELGIQUE

Importeur (Alleen EU)

JVCKENWOOD Europe B.V.
Amsterdamseweg 37, 1422 AC Uithoorn,
NEDERLAND

Manufacturer

JVCKENWOOD Corporation

3-12, Moriya-cho, Kanagawa-ku, Yokohama-shi,
Kanagawa, 221-0022, JAPAN

Contents

Introduction

Safety Precautions	4
Contents	10
Verifying the Accessories	10
Names of Parts	11

Preparations

Settings and Adjustments Before Use	14
Power Supply	17
Initial Settings	20
Adjusting the Back Focus	21
SD Card	22

Shooting

Basic Shooting Procedures	25
---------------------------------	----

Playback

Playing Recorded Clips	26
------------------------------	----

Network

Functions of Network Connection	27
Preparing Network Connection	28
Connecting to the Network	29
Connecting from a Web Browser	30

Others

Menu Screen Hierarchical Chart	31
Basic Operations in Menu Screen	32
Display Screen in Camera Mode	33
Display Screen in Media Mode	38
Status Screen	40
Troubleshooting	41
Precautions for Proper Use	43
Specifications	47
Software License Agreement	50
Important Notice concerning the Software	51

Symbols used

Caution : Describes precautions concerning the operation of this product.

Memo : Describes reference information, such as functions and usage restrictions of this product.

 : Indicates the reference page numbers and reference items.

CHU : Feature available on GY-HC900CHU only.

CHE : Feature available on GY-HC900CHE only.

STU : Feature available on GY-HC900STU only.

RCHE : Feature available on GY-HC900RCHE only.

Verifying the Accessories

Verify that the following accessories are included with the camera recorder before using.

Accessories	
Warranty Card CHU STU	1
INSTRUCTIONS (BASIC)	1
Electronic Viewfinder CHU CHE	1
Cold Shoe Unit	1
Screw (M2)	4
Wireless LAN Antenna CHU CHE	2

* Eyepiece and body cap are attached to the camera recorder.

Names of Parts

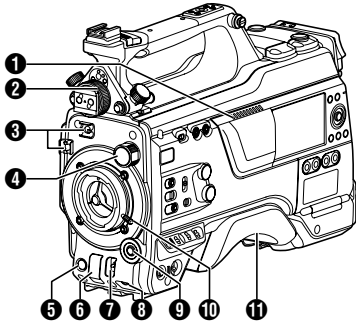

- ❶ Speaker
- ❷ Viewfinder Left-Right Position Lock Ring
- ❸ Cable Clamp
- ❹ [ND FILTER] Switch
- ❺ [REC] Button
- ❻ [SHUTTER] Switch
- ❼ [AWB/USER8] Switch
- ❽ [MIC LEVEL] Knob
- ❾ Cross-shaped (▲▼◀▶)/[SET/USER13] Button (●)
- ❿ Lens Lock Lever
- ⓫ Shoulder Pad

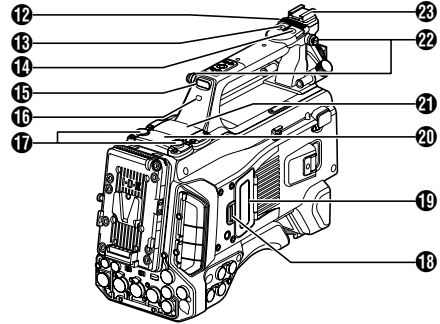

- ❿ Slide Cover (For [USER6]/[USER7] Button)
- ⓫ [USER6] Button
- ⓫ [USER7] Button
- ⓫ Back Tally Lamp (Handle)
- ⓫ [TALLY] Switch
- ⓫ Wireless LAN Antenna Terminal **CHU CHE**
- ⓫ SD Card Cover Knob
- ⓫ SD Card Cover
- ⓫ Expansion slot
- ⓫ Wireless Audio Receiver Mounting Slot ("UniSlot")
- ⓫ Shoulder Belt Mount (x2)
- ⓫ Shoe

Side Control Panel

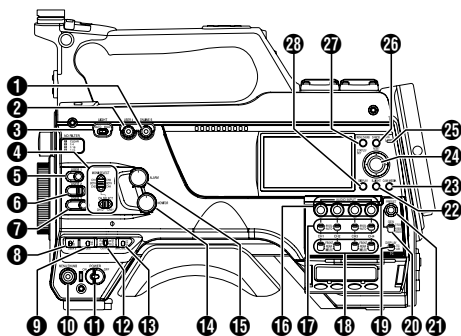

- 1 [ONLINE/5] Button
 - 2 [USER4] Button
 - 3 [LIGHT] Switch
 - 4 [MONI SELECT] Switch/[CH SELECT] Switch
 - 5 [USER1] Button
 - 6 [USER2] Switch
- Memo : _____
- Even when the function assigned to the [USER2] switch is assigned to another user button at the same time, only the [USER2] switch is enabled.
-
- 7 [USER3] Button
 - 8 [USER0] Switch
 - 9 [GAIN H/M/L] Switch
 - 10 [MENU/THUMB] Button
 - 11 [POWER] Switch
 - 12 [OUTPUT] Switch
 - 13 [WHT.BAL PRST/A/B] Switch
 - 14 [MONITOR] Volume Adjustment Knob
 - 15 [ALARM] Volume Adjustment Knob
 - 16 [AUDIO INPUT CH1/2/3/4] Recording Level Adjustment Knob
 - 17 [AUDIO SELECT CH1/2/3/4]-[MANUAL/AUTO] Selection Switch
 - 18 [AUDIO SELECT CH1/2/3/4]-[FRONT/REAR/WIRELESS] Selection Switch

- 19 [TC DISPLAY] TC/UB Display Switch
- 20 [TC GEN] Time Code Generator Switch
- 21 [TC PRESET] Button
- 22 [B.LIGHT] Button
- 23 [CAM/MEDIA] Button
- 24 Cross-shaped (▲▼◀▶)/[STATUS/SET] Button (●)
- 25 [ACCESS] Lamp
- 26 [CANCEL/RESET] Button
- 27 [MENU/THUMB] Button
- 28 [DISPLAY] Button

Side Terminal Section

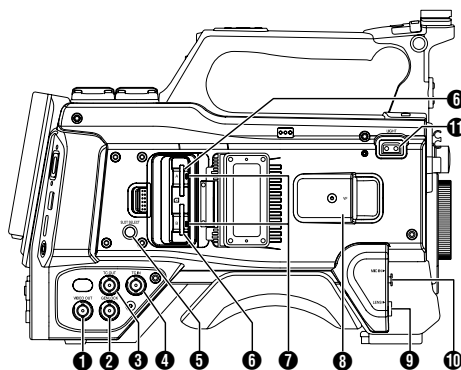

- 1 [VIDEO OUT] Terminal
- 2 [GENLOCK] Terminal
- 3 [TC OUT] Terminal
- 4 [TC IN] Terminal
- 5 [SLOT SELECT] Button
- 6 Card Slot A/B
- 7 Access Lamp A/B
- 8 [VF] Terminal
- 9 [LENS] Lens Connection Terminal
- 10 [MIC IN] Terminal (XLR 5-pin)
- 11 [LIGHT] Terminal

Rear Terminal

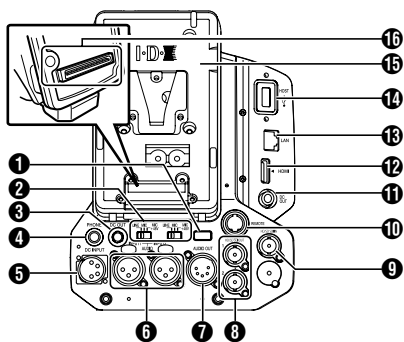

- 1 Back Tally Lamp (Rear)
- 2 [AUDIO INPUT1/2] Switch
- 3 [12V --- 1.8A] DC OUT terminal (Rear)
- 4 [PHONE] Terminal (Φ3.5 mm)
- 5 [DC INPUT] Terminal
- 6 [AUDIO INPUT1/2] Terminal (XLR 3-pin)
- 7 [AUDIO OUT] Terminal (XLR 5-pin)
- 8 [HD/SD SDI OUT1/2] Terminal
- 9 [HD/SD SDI IN] Terminal
- 10 [REMOTE] Terminal
- 11 [12V --- 0.5A] DC OUT (LAN) terminal
- 12 [HDMI] Output Terminal
- 13 [LAN] Terminal
- 14 [HOST] USB Host Terminal
- 15 Battery Loading Folder
- 16 Expansion Unit Terminal

Memo :

- Remove the battery loading folder when using this terminal.

Electronic Viewfinder **CHU** **CHE**

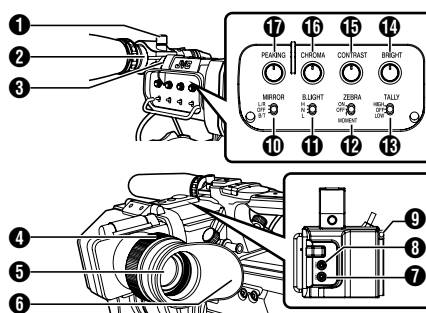

- 1 Microphone Holder Lock Knob
- 2 Microphone Holder
- 3 Front Tally Lamp
- 4 Eyepiece Focus Ring
- 5 Electronic Viewfinder
- 6 Eyepiece
- 7 [USER1] Button (VF)
- 8 [USER2] Button (VF)
- 9 Slide Stopper
- 10 [MIRROR] Switch
- 11 [B.LIGHT] Switch
- 12 [ZEBRA] Switch
- 13 [TALLY] Front Tally Switch
- 14 [BRIGHT] Knob
- 15 [CONTRAST] Knob
- 16 [CHROMA] Knob
- 17 [PEAKING] Knob

Settings and Adjustments Before Use

Attaching the Lens (Sold Separately)

This camera recorder can be attached with a B4 mount lens.

Caution :

- Check that the camera recorder is turned off before attaching the lens. Attaching the lens with the power turned on can result in accident and malfunction.
- When detaching the lens, do not touch the optical filter or allow dust to adhere to the optical filter.

Preparations

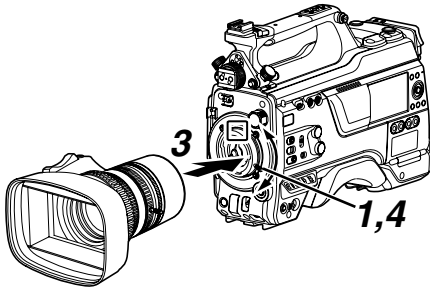

- 1 Loosen the lens lock lever.
- 2 Detach the body cap.
 - Do not lose the body cap, keep it properly.
- 3 Attach the zoom lens such that the pin matches the hole of the mounting area.
- 4 Tighten the lens lock lever.
- 5 Connect the lens cable to the [LENS] terminal.
- 6 Attach the lens cable to the clamp.

Memo :

- Tighten the lens lock lever completely. If it is not fully tightened, the lens may drop or the back focus may be out of alignment.
- For details on the lens, please refer to the "INSTRUCTIONS" of the lens used.
- It is necessary to adjust the back focus before use.
(P21 [Adjusting the Back Focus])

Attaching the Viewfinder [CHU] [CHE]

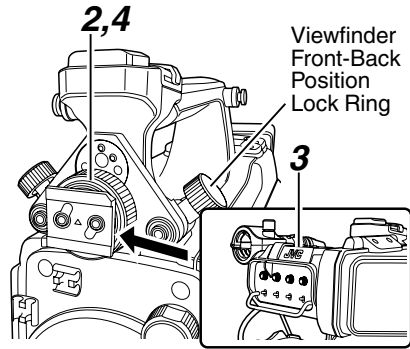

- 1 Set the [POWER ON/OFF] switch of the camera recorder to "OFF".
- 2 Loosen the viewfinder left-right position lock ring.
- 3 Attach the viewfinder by sliding it in the direction of the arrow while pulling up the slide stopper.

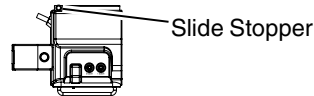

- 4 Turn the viewfinder left-right position lock ring to secure the position of the viewfinder.
- 5 Attach the viewfinder cable to the [VF] terminal.
- 6 Pin the viewfinder cable to the clamp.

Attaching the Microphone (Sold Separately) **CHU** **CHE**

You can attach a separately sold microphone to the microphone holder.

The microphone that is sold separately uses a phantom power supply.

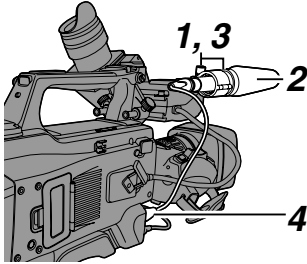

- 1 Turn the knob on the microphone holder counterclockwise to loosen and open the microphone holder.
- 2 Place the microphone in the microphone holder.
- 3 Turn the knob on the microphone holder clockwise to secure the microphone.
- 4 Connect the microphone cable to the [MIC IN] terminal.
- 5 Pin the microphone cable to the clamp.
- 6 Perform the settings for the phantom mic correctly.

Attaching the Video Light (Sold Separately)

Video lights or accessories can be attached to the accessory shoe of this camera recorder.

The accessory shoe is of the 1/4-inch screw type. To make use of a slide shoe, attach the supplied cold shoe unit.

Attaching the Cold Shoe Unit

- 1 Remove the plate from the cold shoe unit. While lifting the catch, slide the plate out.

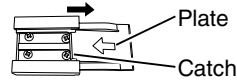

- 2 Attach the cold shoe unit to the shoe of this camera recorder using the four screws supplied.

- 3 Attach the plate to the cold shoe unit. Push the catch up from the bottom and slot the plate into the guide in the direction of the arrow.

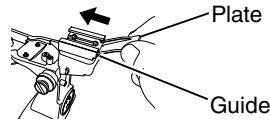

Attaching the Video Light

The [LIGHT] terminal (D-tap) of this camera recorder can be connected with a video light (DC 12 V, maximum power consumption 50 W).

Connect the [LIGHT] terminal after attaching the accessory shoe.

When the [LIGHT] switch is set to "AUTO", the light goes on only during recording in tandem with the camera. When it is set to "MANUAL", the light goes on or turns off respectively when the video light power is turned on or off.

Attaching the Wireless LAN Antennas

CHU CHE

Attach the wireless LAN antenna by turning it in the clockwise direction. Hold the base while attaching the antenna.

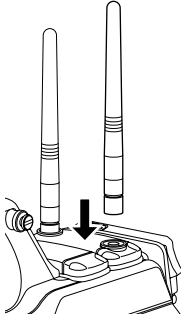

Caution : _____

- Applying force to the wireless LAN antenna or yanking it may damage the antenna so please use caution when using the antenna. If it is damaged, replacement is chargeable even during the warranty period.
(Part number: T9A-0095-00)

Preparations

Attaching the Tripod (Sold Separately)

Mount this camera recorder after attaching the KA-551U tripod base unit to the tripod.

To prevent the camera recorder from falling off, which may result in injuries or damages, read through the instruction manual of the KA-551U as well as that of the tripod to be used and make sure that it is securely attached.

Caution : _____

- If the camera recorder exceeds the weight limit of the tripod, do not mount it on the tripod.
- Use the tripod on a stable surface.

Adjusting the Position of the Shoulder Pad

Adjust the position of the shoulder pad back and forth.

- 1 Release the lock of the lock lever and adjust the position of the shoulder pad back and forth.
- 2 Lock the lock lever and check that the shoulder pad is fixed.



Power Supply

To use this camera recorder, you can attach a battery pack or connect an AC adapter to it.

Caution :

- Set the [POWER ON/OFF] switch to “OFF” before changing the power supply that operates this camera recorder.
- Use the camera recorder and peripheral equipments within the rated output of the AC adapter.
- To connect other peripheral equipment, do so under the following conditions.
 - Keep the total power consumption of the peripheral equipments under 35 W when using the recommended battery.
 - Keep the total power consumption of the peripheral equipments under 65 W when using Tandem 150 (recommended AC adapter).
 - Keep the total power consumption of the peripheral equipments under 50 W when using AC-100 (recommended AC adapter).
- The power consumption of the [LIGHT] terminal is below 50 W. Keep the total power consumption of the peripheral equipments excluding the [LIGHT] terminal under 35 W when using the [LIGHT] terminal.

If the total power consumption of the peripheral equipments exceeds the rating, the power to the [LIGHT], [12V --- 1.8A] DC OUT and [12V --- 0.5A] DC OUT (LAN) terminals is automatically cut off. This is not a malfunction. Use peripheral equipments with lower power consumption then turn on the power of this camera recorder again.
- If the voltage of the [DC INPUT] becomes 12 V or less, the USB adapter connected to the [HOST] terminal cannot be used. Check the power supply and the peripheral equipments, and turn on the power of this camera recorder again.

Using AC Power (DC IN Power)

Use the AC adapter (sold separately) to operate the camera recorder with AC power.

Recommended AC Adapter

U model : Tandem 150 (Anton/Bauer)
E model : AC-100 (IDX)

Memo :

- For the type of AC adapter to be attached on a battery mount, check the method of attachment in [Using a Battery Pack] (P 18).

1 Connect the DC cable of the AC adapter to the [DC INPUT] terminal of the camera recorder.

Check that the power of this unit and that of the AC adapter are both set to “OFF”, followed by connecting according to the diagram.

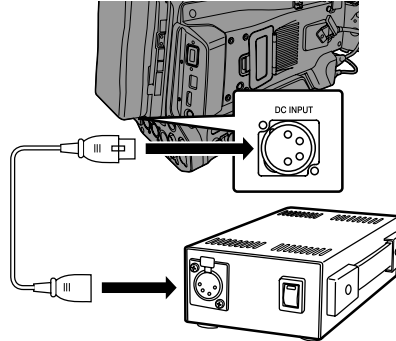

2 Turn on the power of the AC adapter, followed by setting the [POWER ON/OFF] switch of this unit to “ON”.

Power will be supplied to the camera recorder.

Caution :

- Do not insert or remove the DC cable during recording.
- Do not use power supply of high voltage fluctuation, containing noise such as ripple, or with insufficient capacity.

Using a Battery Pack

Recommended Batteries

U model : Dionic HC, Digital 150 (Anton/Bauer)
E model : E-HL9, DUO-150 (IDX)

* Models with an E suffix are for the European market and the UL Listing mark is not applicable.

Caution :

- Make use of the recommended batteries. Heavy batteries may fall off if not used correctly.
- For details on how to charge the battery, please refer to the [instruction manual] of the battery in use.

Battery Operating Time

The following are the approximate times for continuous operation on fully-charged batteries.

Battery	Continuous Recording Time (At 25 °C)
Dionic HC (U model)	Approx. 2.3 hrs
Digital 150 (U model)	Approx. 4.0 hrs
E-HL9 (E model)	Approx. 2.2 hrs
DUO-150 (E model)	Approx. 3.7 hrs

Memo :

- Actual operating times may differ depending on the age of the battery, charging condition, and operating environment.
- Operating time is shortened in cold environment.
- The operating time may shorten when power zoom is used, accessories are connected, or when the LCD monitor is frequently used.

Precautions for the Battery Operation

- Do not remove the battery when the [POWER ON/OFF] switch is "ON".
- Do not insert or remove the DC cable when the battery is in use.
- Leaving the camera recorder unused with the battery attached will deplete the battery power even when you set the [POWER ON/OFF] switch to "OFF". Remove the battery if you are not using the camera recorder.

Attaching/Detaching the Battery (U Model)

Use the Dionic HC or Digital 150 (Anton/Bauer) battery.

- 1 **Align the battery guide pins (x3) with the battery adapter guide hole, and insert them directly.**

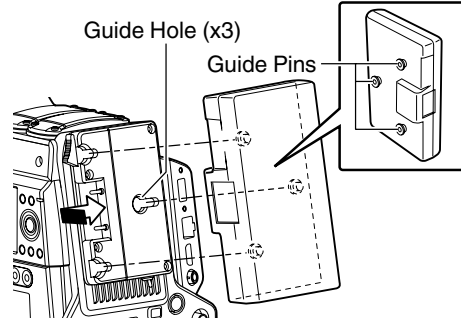

- 2 **Slide the battery in the direction indicated by the arrow until a "click" sound is heard.**

Memo :

- If the guide pins are not inserted straight, the battery will not be attached correctly.

- 3 **Detaching the Battery**

Press down the release lever and slide the battery toward you to detach it from the camera recorder.

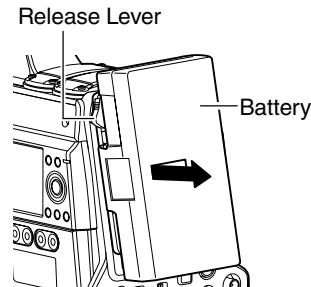

Attaching/Detaching the Battery (E Model)

Use E-HL9 or DUO-150 from IDX.

1 Attach the battery.

Face the terminal downward and attach the V mount of the battery onto the V mount attachment bracket of the camera recorder.

2 Press down the battery until it snaps into place.

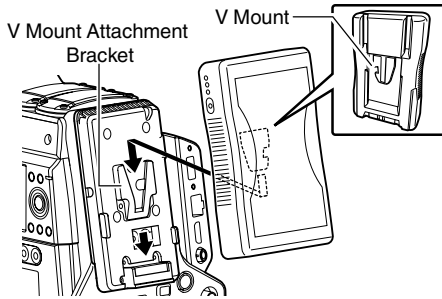

3 Detaching the Battery

Press down the release lever and slide the battery upward to detach it from the camera recorder.

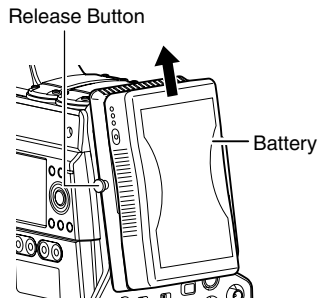

Precautions for Batteries

- Store the battery in a cool and dry place when not in use. Do not expose the battery to high temperatures (such as in a car under direct sunlight). This will cause battery leakage and shorten the battery life.
- Operating time is shortened if the battery terminal is dirty.
- If the operating time shortens drastically even after charging, the battery may be reaching the end of its life. Replace the battery with a new one.

Initial Settings

When the power is first turned on, the Initial Setting screen for performing the initial settings in the camera recorder appears.

Set the date/time of the built-in clock in the [Date/Time] screen.

All operations are disabled until initial settings are complete.

Memo : _____

- It is recommended to use the AC adapter as the power supply.
- Attach the lens cap.

1 Set the [POWER ON/OFF] switch to "ON".

A language selection screen appears.

- For U models



- For E models



Memo : _____

- The menus and messages on the screen of the LCD monitor or viewfinder are displayed in the selected language.

2 Select a language using the cross-shaped button (▲▼), and press the [STATUS/SET] button (●).

A self-diagnosis screen appears.



3 Ensure the lens cap is attached, and press the [STATUS/SET] button (●).

- Self-diagnosis starts.
- A progress bar appears, and "Complete Diagnosis" appears when the diagnosis is complete.

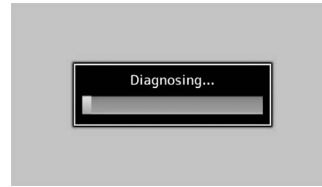

Memo : _____

- It takes about 6 minutes to complete the diagnosis. During the diagnosis, do not operate or turn off the camera recorder.

4 Press the [STATUS/SET] button (●) after confirming the exit screen.

The [Date/Time] screen appears.

- For U models

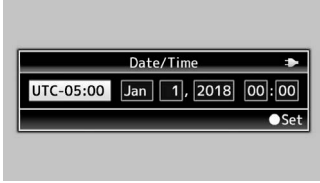

- For E models

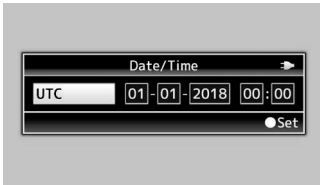

5 Set the time zone and date/time.

- ① Move the cursor with the cross-shaped button (◀▶) and select the setting item.
- ② Change the values with the cross-shaped button (▲▼).
- ⑥ **Press the [STATUS/SET] button (●) after setting is complete.**
The clock is set to 0 seconds of the input date/time.

Memo : _____

- The configured date/time data can be displayed on the LCD monitor and viewfinder and be recorded to the SD card.
- The value of the year can be set in the range of "2000" to "2099".
- The configured date/time data is saved in the built-in battery even if the power is turned off.
- If the date/time data is no longer retained, the built-in battery is dead. For replacement of the built-in battery, please contact the local dealers in your area.

Adjusting the Back Focus

When the lens is attached for the first time, adjust the back focus of the lens if the focus is not clear when it is zoomed to the telephoto or wide-angle end.

- The Siemens Star Chart is most suitable as the subject.

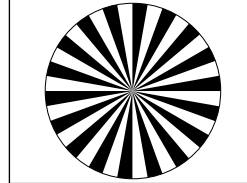

Siemens Star Chart

- 1 Place an object at approximately 3 m away from the camera recorder.
- 2 Open up the iris.
- 3 Set the lens to the telephoto end.
- 4 Turn the focusing ring to adjust the focus.
- 5 Set the lens to the wide-angle end.
- 6 Loosen the F.B. locking screw of the lens and turn the back focus adjustment ring to adjust the focus.
- 7 Repeat the steps from 3 to 6 to adjust the focus at both ends of the zoom.
- 8 After determining the position of the back focus adjustment ring, tighten the F.B. locking screw.

Memo : _____

- For details, please refer to the "INSTRUCTIONS" of the lens.

SD Card

This camera recorder saves the recorded images and audio sound on the SD card (sold separately) in the card slot.

Usable Cards

System	Format	Bit Rate	Usable SD Card
HD	QuickTime(H.264)	50M (YUV422), 50M (XHQ)	UHS-I U1 or higher, or Class 10 or higher
		35M (UHQ)	UHS-I U1 or higher, or Class 6 or higher
	QuickTime(MPEG2)	35M (HQ), 25M (SP)	

Caution :

- Using cards other than those from Panasonic, TOSHIBA or SanDisk may result in recording failure or data loss.

Estimated Recordable Time of SD Cards

The estimated recordable time is only a guide. Differences may occur depending on the SD card in use and the battery condition.

- The following is the recording time during audio 4ch recording. The recording time is longer for 2ch recording.

- When [System] → [Record Set] → [Record Format] → [Format] is set to "QuickTime(MPEG2)"

Resolution	1920x1080, 1440x1080, 1280x720	1440x1080
Bit Rate	HQ	SP
8 GB	24	32
16 GB	48	64
32 GB	96	130
64 GB (SDXC)	192	260
128 GB (SDXC)	384	520
256 GB (SDXC)	768	1040

(Unit: minute)

- When [System] → [Record Set] → [Record Format] → [Format] is set to "QuickTime(H.264)"

Resolution	1920x1080, 1280x720	
	XHQ	UHQ
8 GB	17	24
16 GB	35	48
32 GB	70	96
64 GB (SDXC)	140	192
128 GB (SDXC)	280	384
256 GB (SDXC)	560	768

(Unit: minute)

Memo :

- If the SD card contains files recorded by devices other than this camera recorder or files that are saved from a PC, the recordable time may be shorter or data may not be properly recorded.
- For each file format, up to 600 clips can be recorded to one SD card on this camera recorder. When 600 clips are recorded to one card, the remaining space is displayed as 0 min regardless of the estimated recordable time, and no further recording can be performed.

Inserting an SD Card

This camera recorder comes with two card slots (Slot A and B) for video/audio recording and playback.

- Press the SD card cover knob to open the cover.**
- Insert an SD card with the notched corner pointing up.**
The status indicator of the card slot to which the card was inserted lights up in red.
- Close the SD card cover.**

Formatting (Initializing) SD Cards

When the following cards are inserted, [FORMAT] appears at the remaining media display area. Format the card using the camera recorder menu.

- Unformatted SD cards
- SD cards formatted under different specifications

Caution :

- Be sure to format the SD card on this camera recorder. SD cards formatted on a PC and other peripheral equipment cannot be used on this camera recorder.
- [!RESTORE] appears at the remaining media display area when an SD card that requires restoring is inserted.

1 Select [System] → [Media] → [Format Media].

2 Select the slot of the SD card to be formatted and press the [STATUS/SET] button (●).

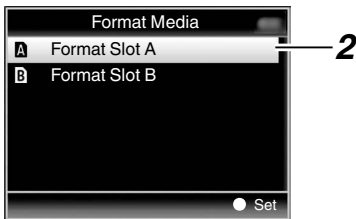

3 The status of the selected SD card appears.

4 Select [Format] and press the [STATUS/SET] button (●).

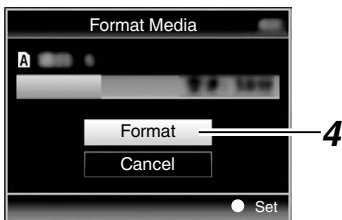

5 Formatting starts.

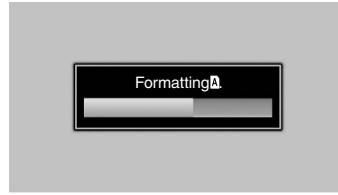

6 Formatting is complete.

When formatting is complete, "Complete" appears and the camera recorder returns to the [Format Media] screen.

Memo :

- During formatting, menu operation is unavailable but you can start recording. However, this is only available when a recordable SD card is inserted in the other slot.
- Formatting cannot be performed in the following cases.
 - Recording is in progress on the SD card to be formatted.
 - SD card is not inserted.
 - Write-protect switch of the SD card is set (🔒 is displayed).

Caution :

- If you format the SD card, all data recorded on the card, including video data and setup files, will be deleted.

Clips Recorded to SD Cards

Folders in the SD Card

Images captured are recorded to the [DCIM] folder.

Memo : _____

- By formatting (initializing) the SD card from the [Format Media] menu on the camera recorder, folders required for recording in the current [System] settings will be generated.
- When the [System] settings and [**A**Format]/ [**B**Format] settings are changed, folders required for recording in those settings will be automatically generated.

Caution : _____

- When a clip inside the folder is moved or deleted using the Explorer (Windows) or Finder (Mac), recording to the SD card may fail if formatting (initializing) of the card is not performed.

Clip (Recorded Data) and Clip Name

- When recording is stopped, the images, audio and accompanying data which are recorded from start to stop are recorded as one "clip" on the SD card.
- An 8-character clip name is automatically generated for the recorded clip. ("Clip Name Prefix" + "Clip Number")

Example: QuickTime

ABCG0001

Clip Number

A number in automatic ascending order is assigned in the recording order.

The Clip Number can be reset in the menu.*

Clip Name Prefix (any four alphanumeric characters)
This is set to "xxxG" ("xxx" denotes the last 3 digits of the serial number) by default.

* [Clip Set] → [Reset Clip Number]

Memo : _____

- Before recording starts, you can set any characters for the clip name prefix by using [System] → [Record Set] → [Clip Set] → [Clip Name Prefix].
- Changes cannot be made after recording.

Recorded Clips

- The recorded materials may be split into several files but they can be played back continuously on the camera recorder.
- Clips may be recorded across the two SD cards in card slots A and B depending on the recording time of the clip.

Caution : _____

- A clip recorded across several cards cannot be played back continuously. Continuous playback is only possible when the recording is made on one card.

Basic Shooting Procedures

Preparations

- 1 **Supply battery or AC adapter power to the camera recorder.**
- 2 **Insert an SD card.**
- 3 **Turn on the power of the camera recorder.**
Setting the [POWER ON/OFF] switch to “ON” starts up the camera recorder in the Camera mode to enable shooting.
- 4 **Adjust the angle of the viewfinder.**
- 5 **Set [System], [Format], [Resolution], [Frame Rate], [Bit Rate] and [Audio] in [System] → [Record Set] → [Record Format].**
 - You can select the definition of the recorded videos, file format for recording/playback, and the video recording format on this camera recorder.
 - Press the [MENU/THUMB] button to display the menu screen on the LCD monitor and viewfinder.

Shooting

- 1 **Configure the video and audio input settings.**
You have to configure video settings such as brightness adjustment (iris, gain, shutter) and white balance adjustment in order to start shooting. You also have to adjust the audio input settings and audio recording level for audio recording.
 - Adjusting the Brightness
 - Adjusting the White Balance
 - Adjusting Audio Input Settings and Recording Level
- 2 **Press the [REC] button to start recording to the SD card.**
The tally lamp lights up in red during recording.
 - Zoom Operation
 - Adjusting the Focus

Memo : _____

- If both the slots are loaded with recordable cards in the factory default, pressing the [REC] button starts recording only to the media in the selected slot.
When [System] → [Record Set] → [Slot Mode] is set to “Dual”, recording can be performed simultaneously to the cards in both the slots.
- The tally lamp can be turned off by setting the [TALLY] switch to “OFF”.

- 3 **Check the most recently captured images.**
 - Press the user button that is assigned with the Clip Review function. Doing so activates the function and plays back the most recently captured images on the LCD monitor and viewfinder screen.
 - After playback, the camera recorder returns to standby mode (STBY).

Playing Recorded Clips

To play back clips recorded on SD cards, switch to the Media mode.

Press and hold the [CAM/MEDIA] selection button in the Camera mode to enter the Media mode. A thumbnail screen of the clips recorded on the SD card is displayed.

You can play back the selected clip on the thumbnail screen.

Memo : _____

- When an SD card without any clips is inserted, "No Clips" is displayed.

Viewing Recorded Videos

Use the operation buttons on the side control panel of the camera recorder to play back.

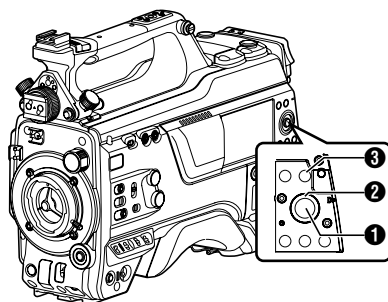

Playback

1 [STATUS/SET] Button (●)

- Plays back/pauses the clip pointed by the cursor.
- You can press the cross-shaped button (◀▶) to perform frame-by-frame forward playback during pause mode.

2 Cross-shaped Button (▲▼◀▶)

- [▲/▼] Button:
Skips in the reverse or forward direction.
- [◀/▶] Button:
 - During Playback:
Fast forwards in the reverse or forward direction.
 - While paused:
Frame-by-frame playback in the reverse or forward direction.

3 [CANCEL/RESET] Button

Stops playback.

1 In the thumbnail screen, move the cursor to the clip to be played back.

Move the cursor to the clip to be played back using the cross-shaped button (▲▼◀▶).

2 Tap the [STATUS/SET] button (●).

Playback of the selected clip starts.

Audio Output during Playback

- You can confirm the playback sound from the monitor speaker, or the headphone connected to the [PHONE] terminal. When a headphone is connected to the [PHONE] terminal, sound cannot be output from the monitor speaker.
- Adjust the volume of the monitor speaker or headphone using the [MONITOR] volume adjustment knob.

Displaying Information during Shooting

Pressing the [DISPLAY] button during playback displays the display screen.

Pressing the [USER4] button during shooting switches the display information between camera information display, GPS display and turning off the display.

Functions of Network Connection

The network feature comprises web-browser-based functions using devices such as a smartphone, tablet terminal, or PC, as well as FTP and live streaming functions that run via thumbnail screens and menu operation.

Connecting to the Network

- [LAN] Terminal
- Built-in Wireless LAN **CHU** **CHE**
- Connect the following adapters to the [HOST] terminal (USB)
 - Wireless LAN adapter
 - Ethernet adapter
 - Cellular adapter

List of Functions

Importing Metadata

You can download a metadata settings file (XML format) from the FTP server and store metadata in the camera recorder.

Uploading Recorded Clips

You can upload clips recorded in the SD card to a preset FTP server.

Memo : _____

- Uploading can also be performed via a web browser.
-

Editing Metadata

- Planning Metadata
You can access the page for editing the camera recorder's metadata via a web browser on devices such as a smartphone, tablet terminal, or PC, and edit the metadata that is to be applied to clips to be recorded.
- Clip Metadata
You can access the page for editing the metadata via a web browser on devices such as a smartphone, tablet terminal, or PC, and display or rewrite the metadata that is recorded to a clip.

View Remote

You can access via a web browser on devices such as a smartphone, tablet terminal, or PC to check the live image or remotely control the camera.

Camera Control

You can access via a web browser on devices such as a smartphone, tablet terminal, or PC to remotely control the camera.

Live streaming

By combining with the decoder or PC application that supports live streaming, you can perform audio and video streaming via the network.

Preparing Network Connection

Operating Environment

Operation has been verified for the following environments.

Computer

- OS: Windows 7
Web browser: Internet Explorer 11
- OS: Windows 10
Web browser: Chrome
- OS: macOS 10.13
Web browser: Safari 10

Smartphone/Tablet Terminal

- OS: iOS11 (iPhone X)
Web browser: Safari 11
- OS: iOS11 (iPad Pro)
Web browser: Safari 11
- OS: Android 6 (Smartphone)
Web browser: Chrome
- OS: Android 7 (Tablet)
Web browser: Chrome



Network

Camera Setup for Network Connection

1 Connect using the corresponding method of connection

- [LAN] Terminal
Connect a PC to this camera recorder directly using a cross-over cable or via devices such as an Ethernet hub using a LAN cable.
- Built-in Wireless LAN **CHU** **CHE**
Attach the wireless LAN antenna if it is not mounted.
- Connect the following adapters to the [HOST] terminal (USB)
 - Wireless LAN adapter
 - Ethernet adapter
 - Cellular adapter

Memo :

- Only a network connection adapter can be connected to the [HOST] terminal (USB).
- Connect or disconnect an adapter only after you have turned off the power of the camera recorder.
- You can find the latest information on the compatible adapters at the product page of our website.
- Two types of network coverage (WAN and LAN) are available for each application.

2 Configure the default gateway

Configure according to the connection in [Network] → [Connection Setup] → [Default Gateway].

Connecting to the Network

Connecting to Network via [LAN] Terminal

1 Configure the connection settings with [LAN Wizard].

- Select [Network] → [Connection Setup] → [LAN Wizard] and configure the settings according to the instructions on the screen. Perform setting for the following.
 - IP address setting (DHCP or manual)
 - IP Address
 - Subnet mask
 - Default gateway
 - DNS Server

Memo : _____

- When an address is manually assigned in a NAT environment, it is also necessary to set the default gateway correctly besides conversion of the address at the router's end in order to perform operations such as access to the Internet from an external network via the router.

2 Setting is complete.

After setting is complete, you can access the camera recorder via a web browser.

Connecting to Network via Built-in Wireless LAN [CHU] [CHE] or [HOST] Terminal (USB)

[CHU] [CHE]

1 Set the network connection for USB/Wireless LAN to "On".

- Select [Network] → [Connection Setup] → [USB/Int. WLAN] and configure the setting to "On".

2 Configure the connection settings with [Wizard].

- Select [Network] → [Connection Setup] → [Wizard] and configure the settings according to the instructions on the screen.

[STU] [RCHE]

1 Configure the connection settings with [USB Wizard].

- Select [Network] → [Connection Setup] → [USB Wizard] and configure the settings according to the instructions on the screen.

Configure the settings for the following according to the type of connection.

■ USB wireless LAN connection/built-in wireless LAN connection [CHU] [CHE]

- Mode of connection
- Configuration method

* For P2P connections, it is necessary to configure the [Passphrase] according to the steps below after the above settings are configured.

- ① Set the camera recorder to the Camera mode, and display the status screen ([USB/Int. WLAN] screen [CHU] [CHE] or [USB] screen [STU] [RCHE]).

- Press the [STATUS/SET] button on the camera recorder to display the status screen.

Press the cross-shaped button (◀▶) to display the [USB/Int. WLAN] screen [CHU] [CHE] or [USB] screen [STU] [RCHE].

- Check to ensure that the [Passphrase] and [Passphrase] that you have set in the wizard are displayed.

- ② Select an SSID from the list of access points (smartphone, tablet terminal, PC, etc.) and enter a passphrase.

- Display the list of access points in the wireless connection settings of the smartphone, tablet terminal, or PC, and select "HC900-****". (**** are numbers that vary with the device used.)

- After the password confirmation screen appears, enter the [Passphrase] displayed on the [USB/Int. WLAN] screen [CHU] [CHE] or [USB] screen [STU] [RCHE].

- USB wired LAN connection
 - IP address setting (DHCP or manual)
 - IP Address
 - Subnet mask
 - Default gateway
 - DNS Server

Memo : _____

- When an address is manually assigned in a NAT environment, it is also necessary to set the default gateway correctly besides conversion of the address at the router's end in order to perform operations such as access to the Internet from an external network via the router.

- USB cellular adapter connection
 - Connection phone number
 - User name
 - Password

Caution : _____

- You can access the web functions via a web browser on devices such as a smartphone, tablet terminal, or PC only in a LAN environment.
- Note that you may have to pay very high bills in the case of pay-per-use contracts. Fixed price contract is recommended if you are using the network function.
- Note that the use of improper settings may result in expensive bills from the phone service provider. Make sure that the setting is correct.
- To avoid expensive bills due to the roaming connection, you are recommended to use this function by disabling the roaming contract.
- There may be communication even when you are not using the network function. Remove the cellular adapter when the function is not in use.

3 Setting is complete.

After setting is complete, you can access the camera recorder via a web browser.

Connecting from a Web Browser

You can access the web functions of this camera recorder via a web browser on devices such as a smartphone, tablet terminal, or PC. Make the necessary preparations for connection in advance.

- 1 **Set the camera recorder to the Camera mode, and display the status screen ([LAN] or [USB/Int. WLAN] screen **CHU CHE** or [USB] screen **STU RCHE**).**
 - Press the [STATUS/SET] button on the camera recorder to display the status screen. Press the cross-shaped button (◀▶) to display the [LAN] or [USB/Int. WLAN] screen **CHU CHE**, or [USB] screen **STU RCHE**.
 - Check the displayed [IP Address].
- 2 **Start up the web browser on the terminal you wish to connect to the camera recorder, and enter the [IP Address] in the address field. (Example: 192.168.0.10)**
If "192.168.0.10" is displayed in [IP Address], enter "http://192.168.0.10".

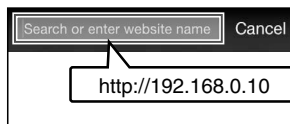

- 3 **Enter the user name and password.**
Enter the user name and the password on the login screen to display the main page of the camera.
 - Check the [Web Username] and [Web Password] in the [Network] screen (status screen).

Memo : _____

- The user name and password can be changed in [Network] → [Web] → [Username] and [Password].

Menu Screen Hierarchical Chart

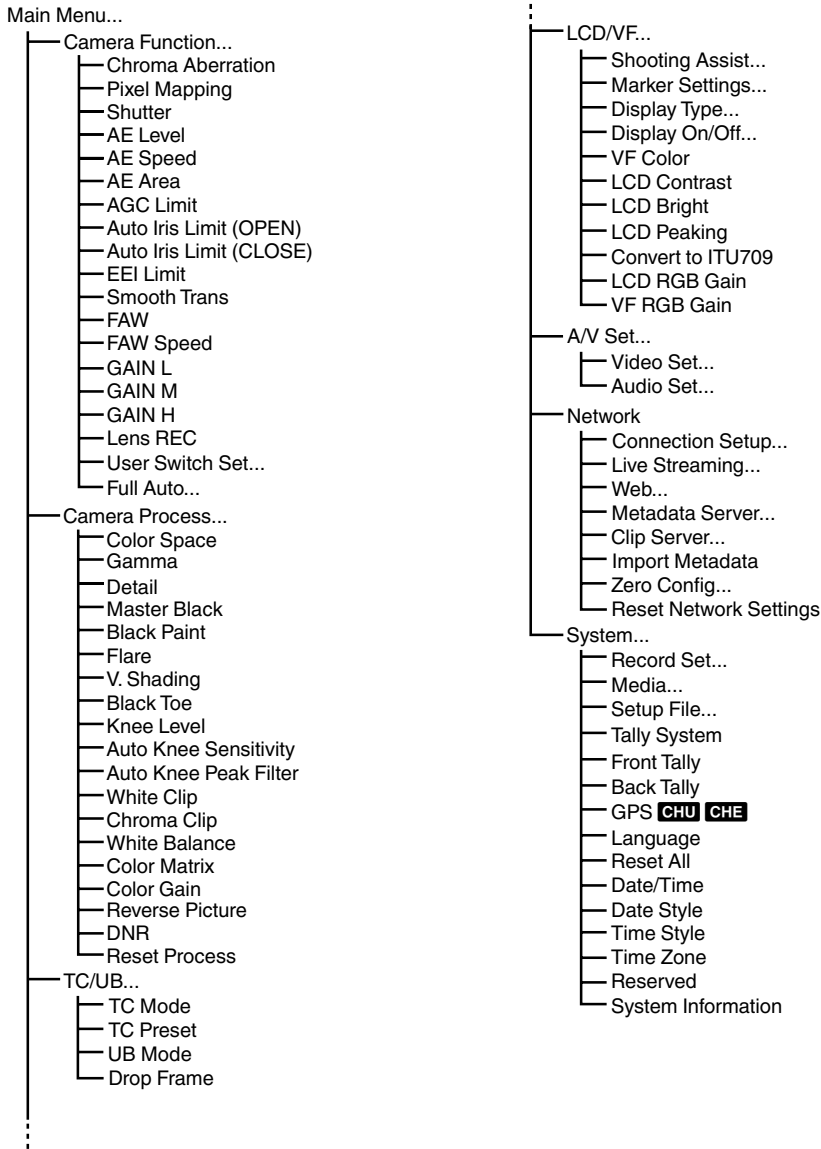

* Only menu items that can be set using this camera recorder are introduced here. For details on each item, please refer to the "Mobile User Guide".

Basic Operations in Menu Screen

- Pressing the [MENU/THUMB] button displays the menu screen on the LCD monitor and viewfinder.
- Various settings for shooting and playback can be configured on the menu screen.
- There are two types of menu screens - [Main Menu] and [Favorites Menu].
- [Main Menu] contains all the setting items of the camera recorder, classified according to functions and uses, while [Favorites Menu] allows users to customize the menu items freely.
- The operating procedures and main screen displays are the same for both menus.
- The menu screen can also be displayed on external monitors connected to the video signal output terminal.

Operation Buttons

To operate the menu, use the cross-shaped buttons on the side operation panel of the camera recorder or the cross-shaped buttons at the front of the camera or at the bottom of the lens.

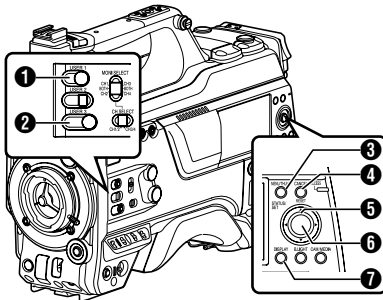

- 1 [USER1] Button**
Adds the selected menu or submenu item to the [Favorites Menu].
- 2 [USER3] Button**
Resets settings in the [TC Preset] or [UB Preset] setting screen.
- 3 [MENU/THUMB] Button**
 - Displays the menu screen. The [Main Menu] screen is displayed by default.
 - During normal usage, [Main Menu] is displayed if the previous menu operation ended at [Main Menu], and [Favorites Menu] if the previous menu operation ended at [Favorites Menu].
 - Press this button to close the menu screen during menu display and return to the normal screen.
 - Pressing and holding down the button while the menu is displayed switches the [Main Menu] screen to the [Favorites Menu] or vice versa.
- 4 [CANCEL/RESET] Button**
Cancels settings and returns to the previous screen.
- 5 Cross-shaped Button (▲▼◀▶)**
 - ▲ : Moves the cursor upward.
 - ▼ : Moves the cursor downward.
 - ◀ : Moves back to the previous item.
 - ▶ : Moves forward to the next item.
- 6 [STATUS/SET] Button (●)**
Sets the values and items.
- 7 [DISPLAY] Button**
Switches between the [Main Menu] and [Favorites Menu] screens.

Others

Display Screen in Camera Mode

When the display setting for [LCD/VF] → [Display On/Off] is set to "Off", the corresponding display is hidden but it will appear for approximately 3 seconds when changes are being made.

Memo : _____

- When the display screen is turned off, it will appear only in the following cases.
 - Approximately 3 seconds when changes are being made
 - During event display or warning display

Display Screen

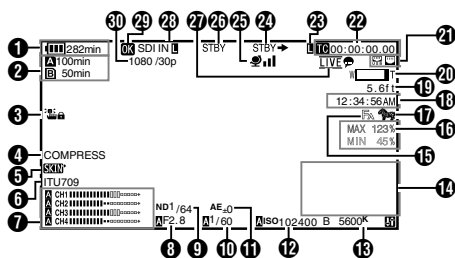

Enlarged Display

Enlarged Display (LCD Monitor Only)

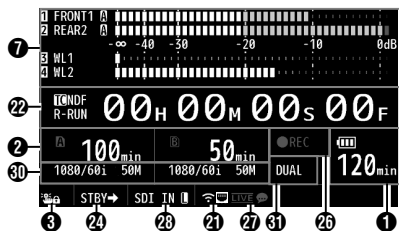

Memo : _____

- Only the display on the LCD monitor is enlarged.

1 Voltage/Battery Power

Displays the current status of the power supply in use.

Memo : _____

- Even when the display screen is turned off and [LCD/VF] → [Display On/Off] → [Battery] is set to "Off", this will be displayed when there is a warning.

2 Remaining Space on Media

Displays the remaining recording time of the SD cards in slot A and slot B separately.

- A** : Currently selected slot. (White card)
- A** : Write-protect switch of SD card is set.
- A!**INVALID : SD card cannot be read or written to, or restored.
- A!**FORMAT : SD card requires formatting.
- A!**RESTORE : SD card requires restoring.
- A!**INCORRECT :
 - When the SD card is not supported.
 - When an SD card lower than Class 10 is inserted while in the XHQ mode.
- A!**REC INH :
 - When attempting to record more than 4 GB while a media that does not support recording of more than 4 GB is inserted.

The following icons are displayed during FTP upload.

Icon	Status
	FTP transfer is in progress. Three images are alternately displayed, and the arrows become animated. In this case, instead of the recordable time of the SD card, an estimated value of the remaining transfer time is displayed.
 (Yellow)	Error has occurred during FTP transfer.

Memo : _____

- The displayed time is an estimate.
- Even when the display screen is hidden and [LCD/VF] → [Display On/Off] → [Media Remain] is set to "Off", this will be displayed when there is a warning.
- Even when the display screen is turned off, this will be displayed in the following cases.
 - When recording is performed to only one of the slots while [System] → [Record Set] → [Slot Mode] is set to "Dual".

Others

3 Operation lock

The  icon appears during operation lock.

Memo : _____

- The  icon appears for 3 seconds after operation lock is turned off.

4 Black Toe

Displays the Black Toe setting.

Memo : _____

- The “Normal” appears for 3 seconds after changing to Normal.

5 Skin Detail

 appears when Skin Detail is functioning.

Memo : _____

-  appears for 3 seconds after Skin Detail is turned off.

6 Color Space Display

Displays the color space.

Memo : _____

- This can be configured in [Camera Process] → [Color Space].

7 Audio Level Meter

- Displays the audio levels for CH-1 to CH-4.
-  appears on the screen when in the Auto mode.



- This is grayed out when in a mode that does not support audio recording or when the audio is not supported. The CH display is grayed out in the enlarged display mode.



- When in the enlarged display mode, the display changes with the setting of the [AUDIO INPUT CH1/CH2/CH3/CH4] selection switch.

Example: During 1ch and 3ch display

FRONT1: When the selection switch is set to “FRONT” and [Front Mic Select] is set to a value other than “Mono”

FR1+2: When the selection switch is set to “FRONT” and [Front Mic Select] is set to “Mono”



REAR1: When the selection switch is set to “REAR”

WL1: When the selection switch is set to “WIRELESS”

8 Iris F-Number

Displays F-number of the lens iris.

Memo : _____

- This item may not be displayed depending on the lens used.
- A  icon appears on the left side of the lens aperture value (F-number) during Auto Iris mode.
- While in the Auto Iris mode, and [AE Lock] is set to “AE” or “AE/FAW”, a  icon appears on the left side of the lens aperture value (F-number) during lock operation.

9 ND Filter Position

Displays the current ND filter position.

10 Shutter

- The current shutter speed appears on the screen.
- When the camera recorder is switched to the Full Auto shooting mode using the user button that is assigned with “Full Auto” or when it is switched to the Automatic Shutter mode with [Camera Function] → [Shutter] set to “EEI”, the **A** icon appears on the left side of the shutter speed.

Memo : _____

- The variable range of the shutter speed varies according to the video format settings.
- While in the Automatic Shutter mode, and [AE Lock] is set to “AE” or “AE/FAW”, a **L** icon appears on the left side of the shutter speed during lock operation.
- [OFF] is displayed when the shutter is turned off or when in the Low-light shooting mode.

11 AE Level

- Displayed when the AE function is activated.
- When operated while manual operation is disabled, “AE” blinks for about 5 seconds.

12 Gain

- You can select to display the gain in “dB” or “ISO”.
- Displays the gain value when in the Manual Gain mode.
- A **A** icon appears on the left side of the gain value in the “AGC” mode.
- “LUX” is displayed to the left of the gain value when in the Low-light shooting mode.

Memo : _____

- While in the “AGC” mode, and [AE Lock] is set to “AE” or “AE/FAW”, a **L** icon appears on the left side of the gain value during lock operation.

13 White Balance Mode

Displays the current white balance mode. (****K indicates color temperature)

A **K** : When the [WHT BAL B/A/PRST] switch is set to “A” in the Manual White Balance mode.

B **K** : When the [WHT BAL B/A/PRST] switch is set to “B” in the Manual White Balance mode.

P **K** : When the [WHT BAL B/A/PRST] switch is set to “PRST” in the Manual White Balance mode.

A FAW : During Full Auto White Balance mode.

L FAW : While in the Full Auto White Balance mode, and [AE Lock] is set for “FAW” or “AE/FAW” during lock operation.

Memo : _____

- When [Preset Paint], [AWB Paint] or [FAW Paint] is set to a setting other than the default value, a **K** icon is displayed to the right of the color temperature.

14 Expanded Focus/Video Signal Monitor/Return Video (PiP)

Displayed upon pressing the user button that is assigned with “Expanded Focus”, “Video Signal Monitor” and “Return Video” (PiP).

Memo : _____

- The order of display is “Expanded Focus” > “Video Signal Monitor” > “Return Video” (PiP).

15 Focus Assist

- “**F_A**” is displayed when auto focus is activated.
- When ACCU-Focus is enabled, “ACCU **F_A**” blinks for about 10 seconds while Focus Assist starts up, after which the “**F_A**” indicator lights up.
- If recording starts while [ACCU-Focus] is active, [ACCU-Focus] will be forcibly deactivated.

- 16** Luminance Information
 Displayed when the Spot Meter function is activated.
 MAX : Maximum luminance
 MIN : Minimum luminance
- 17** Zebra pattern
 During zebra pattern display,  (zebra icon) is displayed on the display screen in Camera mode.
- 18** Time Display
 Displays the current time.

Memo : _____

- The date/time display style can be configured in [System] → [Date/Time].
- When [System] → [Record Set] → [Time Stamp] is set to “On”, this item is not displayed.

- 19** Focus Display
 Displays the approximate distance to the subject in focus during manual focus.

Memo : _____

- The displayed unit of measurement (feet or meter) can be configured in [LCD/VF] → [Display Type] → [Focus].
- This item may not be displayed depending on the lens used.

- 20** Zoom Display
 • Displays the zoom position. (Zoom bar or value)







- The zoom bar will only be displayed for 3 seconds after the zoom operation is activated.
- The value will always be displayed. (Z00 to 99)

Memo : _____

- The mode of display (value or bar) can be configured in [LCD/VF] → [Display Type] → [Zoom].
- This item may not be displayed depending on the lens used.

- 21** Network Connection Icon
- USB connection or built-in wireless LAN connection **CHU CHE**
 - Set [Network] → [Connection Setup] → [USB/Int. WLAN] to “On”. **CHU CHE**
 - In the case of connecting to an external network, check the destination in [Network] → [Connection Setup] → [Default Gateway].

Icon	Status
	Wireless LAN connection from the host terminal (USB) is established
	Wired LAN connection from the host terminal (USB) is established
	Cellular adapter connection from the host terminal (USB) is established
	When a USB adapter different from the connection settings is detected
	Built-in wireless LAN connection is established CHU CHE
(No display)	<ul style="list-style-type: none"> • When [USB/Int. WLAN] is set to “Off” CHU CHE • When an unusable USB adapter is detected

Memo : _____

- The icon appears blinking when the camera recorder is starting up, and is displayed in yellow while getting ready to connect.

- LAN terminal connection
 In the case of connecting to an external network, check the destination in [Network] → [Connection Setup] → [Default Gateway].

Icon	Status
	LAN terminal connection is established
(No display)	When the LAN cable is not connected

Memo : _____

- The icon appears blinking when the camera recorder is starting up, and is displayed in yellow while getting ready to connect.

22 Time Code (TC)/User's Bit (UB) Display

- Displays the time code (hour: minute: second: frame) or user's bit data.
- Example of time code display:
Display Screen

TC00:00:00:00

- * Colon (:) denotes non-drop frames and dot (.) denotes drop frames.

Enlarged Display
[NDF] is displayed to the right of [TC] in the case of non-drop frames and [DF] in the case of drop frames.

TC NDF R-RUN 00_H 00_M 00_S 00_F



- Example of user's bit display:
Display Screen

UBFF EE DD 20

Memo : _____

- Use the [TC DISPLAY] switch to toggle between the time code display and user's bit display.

23 Time Code Lock Indicator

When the built-in time code generator is synchronized to the external time code data input during the synchronization of time code with another camera recorder,  lights up. When in the enlarged display mode, [EXT

24 SDI/HDMI Record Trigger

- STBY → : When [SDI Rec Trigger] is set to "Type-A" or "Type-B", or [HDMI Rec Trigger] is set to "On" and recording is stopped
- REC → : When [SDI Rec Trigger] is set to "Type-A" or "Type-B", or [HDMI Rec Trigger] is set to "On" and recording is in progress

25 GPS Mark

When [System] → [GPS] is set to "On", the signal reception status is displayed.

Memo : _____

- The display changes according to the signal reception sensitivity. If signals cannot be received, the  mark appears in yellow regardless of the [LCD/MF] → [Display On/Off] → [GPS] setting.
- This item is not displayed when [GPS] is set to "Off".



26 Media Status

- : A card is not detected in the selected slot, and [Tally System] is also not set to "Studio"
- STBY : Recording standby
- REC : Recording
- REVIEW : Clip Review
- STOP : Unable to record to the card in the slot
- P.OFF : Power OFF
- CALL : Receiving call signals from an external device, such as a remote control unit
- PGM : Receiving program signals from an external device, such as a remote control unit
- PVW : Receiving preview signals from an external device, such as a remote control unit

Others

27 Live streaming mark

When [Network] → [Live Streaming] → [Live Streaming] is set to “On”, the distribution status is displayed.

Icon	Status
 (Red)	Distribution in progress (good connection quality)
 (Red)	Distribution in progress (poor connection quality)
 (Yellow)	Connection pending or connection failed

28 SDI Input Mode

“SDI IN” is displayed when a device is connected to the [HD/SD SDI IN] terminal, and [System] → [Record Set] → [Record Format] → [System] is set to “HD(SDI In)”.

29 OK Mark

Displayed when OK mark has been appended.

30 Recording Format/Bit Rate (Enlarged Display Mode Only)

Displays the recording format and bit rate (only when in the enlarged display mode).

Memo : _____

- The resolution, frame rate and bit rate can be viewed on the status screen.

31 Dual Rec Display (Enlarged Display Mode Only)

“DUAL” appears in Dual Rec mode.
Memo : _____
• Displayed only when in the enlarged display mode.

Display Screen in Media Mode

When the display setting for [LCD/VF] → [Display On/Off] is set to “Off”, the corresponding display is hidden.

Memo : _____

- Display on the information display area can be toggled using the [USER4] button.
- When the display screen is turned off, it will appear only in the following cases.
 - During event display or warning display
- If “VF Display” is assigned to the [USER1(VF)] button or [USER2(VF)] button of the viewfinder, the corresponding button can also be used in the Media mode.

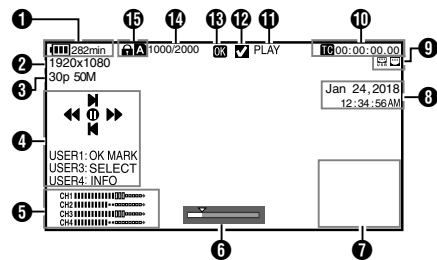

1 Voltage/Battery Power

Displays the current status of the power supply in use.

Memo : _____

- Even when the display screen is turned off and [LCD/VF] → [Display On/Off] → [Battery] is set to “Off”, this will be displayed when there is a warning.

2 Resolution

Displays the video image resolution.

3 Frame Rate/Bit Rate

Displays the frame rate and bit rate in pairs.

4 Operation Guide

Displays a guide for the current operation buttons.

5 Audio Level Meter

- Displays the audio levels for CH-1 to CH-4.

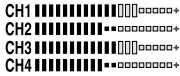

6 Position Bar

Displays the current position in the video. During trimming, the position bar appears in green, and icons for the in and out points are displayed.

- ▼ : Current position of the video
- ▲ : Position to start trimming (In point)
- ▲ : Position to end trimming (Out point)

7 Information Display

Use the [USER4] button to switch between camera information display, GPS display and turning off the display.

- The GPS display displays information on the recording location of the video being played back only when GPS information has been recorded.
- Camera information display displays only information of Gain, Iris, Shutter and White Balance that have been recorded.

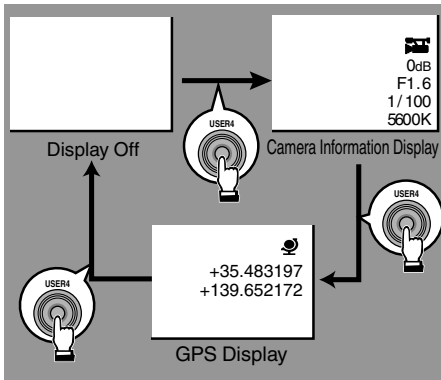

Memo :

- Trimming information is displayed while trimming is in progress. In this case, pressing the [USER4] button does not switch the display.
- The information display area is not subject to the display settings of the items in [LCD/VF] → [Display On/Off].

8 Date/Time Display

Displays the date/time that is recorded on the currently played SD card.

Memo :

- The date/time display style can be specified in [System] → [Date Style]/[Time Style].

9 Network Connection Icon

- USB connection or built-in wireless LAN connection **[CHU CHE]**
 - Set [Network] → [Connection Setup] → [USB/Int. WLAN] to “On”. **[CHU CHE]**
 - In the case of connecting to an external network, check the destination in [Network] → [Connection Setup] → [Default Gateway].

Icon	Status
	Wireless LAN connection from the host terminal (USB) is established
	Wired LAN connection from the host terminal (USB) is established
	Cellular adapter connection from the host terminal (USB) is established
	When a USB adapter different from the connection settings is detected
	Built-in wireless LAN connection is established [CHU CHE]
(No display)	<ul style="list-style-type: none"> • When [USB/Int. WLAN] is set to “Off” [CHU CHE] • When an unusable USB adapter is detected

Memo :

- The icon appears blinking when the camera recorder is starting up, and is displayed in yellow while getting ready to connect.
 - LAN terminal connection
In the case of connecting to an external network, check the destination in [Network] → [Connection Setup] → [Default Gateway].

Icon	Status
	LAN terminal connection is established
(No display)	When the LAN cable is not connected

Memo :

- The icon appears blinking when the camera recorder is starting up, and is displayed in yellow while getting ready to connect.

Others

- ⑩ Time Code (TC)/User's Bit (UB) Display
- Displays the time code (hour: minute: second: frame) or user's bit data recorded in the SD card being played back.
 - Example of time code display:

TC00:00:00:00
↓
*

- * Colon (:) denotes non-drop frames and dot (.) denotes drop frames.

- Example of user's bit display:

UBFF EE DD 20

Memo : _____

- Use the [TC DISPLAY] switch to toggle between the time code display and user's bit display.

⑪ Media Status

PLAY : Playing
 STILL : Still picture playback mode
 FWD * : High-speed playback in the forward direction (* playback speed: 5x, 15x, 60x, or 360x)
 REV * : High-speed playback in the reverse direction (* reverse playback speed: 5x, 15x, 60x, or 360x)
 STOP : Stop mode
 P.OFF : Power OFF

⑫ Check Mark

Displayed when the currently played clip is selected.

⑬ OK Mark

Displayed when OK mark has been appended.

⑭ Clip Information

Displays current clip number/total number of clips.

⑮ Media

- Displays the media slot (A or B) of the currently played clip.
-  appears when the write-protect switch of the SD card is set.

Status Screen

- This screen allows you to check the current settings.
- To display the status screen, press the [STATUS/SET] button in the normal screen.
- Press the [STATUS/SET] button to switch to the status screen.
- Press the [MENU/THUMB] button at each status screen (other than the [Camera Information] and [Power] screen) to enter the setting screen.
- Use the cross-shaped button (◀▶) to switch between the screens.

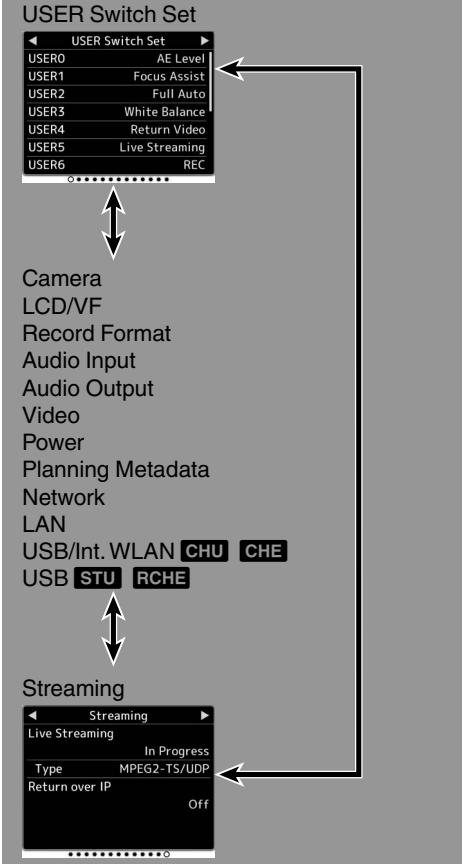

The screenshot shows the 'USER Switch Set' screen with the following settings:

USER0	AE Level
USER1	Focus Assist
USER2	Full Auto
USER3	White Balance
USER4	Return Video
USER5	Live Streaming
USER6	REC

Below this is a list of camera settings: Camera LCD/VF, Record Format, Audio Input, Audio Output, Video, Power, Planning Metadata, Network, LAN, USB/Int. WLAN (CHU, CHE), and USB (STU, RCHE).

The 'Streaming' screen shows:

Live Streaming	In Progress
Type	MPEG2-TS/UDP
Return over IP	Off

Arrows indicate navigation between the 'USER Switch Set' and 'Streaming' screens.

Others

Troubleshooting

Symptom	Action
Power does not turn on.	<ul style="list-style-type: none"> • Is the AC adapter properly connected? • Is the battery charged? • Is the power turned on immediately after it is turned off? Make sure to wait for an interval of at least 5 seconds before turning on the power again.
Unable to start recording.	<ul style="list-style-type: none"> • Is the write-protect switch of the SD card turned on? Make sure that the write-protect switch is turned off. • Is the camera recorder set to the Camera mode? Use the [CAM/MEDIA] selection button to switch to the Camera mode. • Is the SD card inserted compatible with the recording format?
Camera image is not output on the LCD monitor and viewfinder screen.	<ul style="list-style-type: none"> • Is the camera recorder set to the Camera mode? Use the [CAM/MEDIA] selection button to switch to the Camera mode.
Playback does not start after selecting a clip thumbnail and pressing the [STATUS/SET] button (●).	<ul style="list-style-type: none"> • Is the selected clip a playable clip? Playback is not possible if the clip has a different video format setting.
Images on the LCD monitor and viewfinder screen appear dark or blurred.	<ul style="list-style-type: none"> • Readjust the brightness of the LCD monitor and viewfinder. • Is the [ND FILTER] switch set to "1/64"? • Is the iris closed? • Is the shutter speed setting too high? • Is the peaking level too low? For the LCD monitor, adjust the outline with [LCD/VF] → [LCD Peaking]. For the viewfinder, adjust the outline with the [PEAKING] knob on the viewfinder. CHU CHE
The [CH-1/CH-2] recording level adjustment knob does not work.	<ul style="list-style-type: none"> • Is the [AUDIO SELECT CH1/2]-[MANUAL/AUTO] selection switch set to "AUTO"? • Is Full Auto enabled? Is [Camera Function] → [Full Auto] → [Audio] set to "Auto" in Full Auto mode?
[CH-3/CH-4] audio is not recorded.	<ul style="list-style-type: none"> • Is the number of recording channels set to "4ch"? Set [System] → [Record Set] → [AAudio]/[BAudio] to "4ch".
SD card cannot be initialized (formatted).	<ul style="list-style-type: none"> • Is the write-protect switch of the SD card turned on? Make sure that the write-protect switch is turned off.
Battery alarm appears even after loading a charged battery.	<ul style="list-style-type: none"> • Is the battery too old?
The time code and user's bit are not displayed.	<ul style="list-style-type: none"> • Even in Camera mode or Media mode, the time code and user's bit may not be displayed depending to the type of display. • Is [LCD/VF] → [Display On/Off] → [TC/UB] set to "Off"? To display the date and time, set it to "On".

Symptom	Action
The time is not displayed.	<ul style="list-style-type: none"> The time is only displayed on the display screen in the Camera mode (during shooting). Is [System] → [Record Set] → [Time Stamp] set to “On”? To display the date and time, set it to “Off”.
The actual recording time is shorter than the estimated time.	<ul style="list-style-type: none"> The recordable time may be shorter depending on the shooting conditions or the subject.
The two camera recorders are not synchronized even though the time codes have been synchronized. (L on the Slave device is not displayed.)	<ul style="list-style-type: none"> Is the [TC GEN] switch set to “FREE”? Set [System] → [Record Set] → [Record Format] → [Frame Rate] such that the two camera recorders have the same frame rate.
Cannot connect to wireless LAN.	<ul style="list-style-type: none"> Check the mode of connection and method of setting ([SSID] and [Passphrase] in cases other than WPS). Even if the Passphrase is wrong, “Completed the Setup Wizard. Please Input the Passphrase into Your Device.” may appear at the browser setting depending on the type of encryption. Adjust [Passphrase] again. Set [Network] → [Connection Setup] → [Default Gateway] to a value other than “LAN”.
The View Remote screen turns black. The screen flickers. The screen freezes. Cannot perform remote operation.	<ul style="list-style-type: none"> The network path is congested. Wait a while before refreshing (reloading) the web browser.
The clips cannot be uploaded to the FTP server.	<ul style="list-style-type: none"> Adjust the [Clip Server] settings. If a file size limit is set in the FTP server, set the size limit such that it is larger than the maximum size of the recorded clip.
The wireless LAN is disconnected.	<ul style="list-style-type: none"> The wireless LAN may be disconnected depending on the environment. Change the usage environment. Connect via wired LAN.
The images and audio sound during live streaming are choppy.	<ul style="list-style-type: none"> Depending on the connection method to the network and connection environment, streaming may not be possible with the encoding bit rate specified. Please reduce the encoding bit rate.
GPS signal cannot be received. CHU CHE	<ul style="list-style-type: none"> Signal reception from GPS satellites may be affected by buildings or trees. Perform positioning preferably at an unobstructed location with a clear view. Radio wave reception may be affected by weather conditions such as on a cloudy or rainy day.
The position is not accurate. CHU CHE	<ul style="list-style-type: none"> The precision error may be up to hundreds of meters if the GPS signal is weak or reflected off surrounding buildings.

Precautions for Proper Use

| Storage and Usage Locations

- Allowable ambient temperature and humidity
Be sure to use this unit within the allowable temperature range of 0 °C to 40 °C (32 °F to 104 °F) and a relative humidity of 30 % to 80 %. Using this unit at a temperature or humidity outside the allowable ranges could result not only in malfunction but also serious impact on the CMOS elements as small white spots may be generated. Please exercise care during use.
- Strong electromagnetic waves or magnetism
Noise may appear in the picture or audio and/or the colors may be incorrect if this unit is used near a radio or television transmitting antenna, in places where strong magnetic fields are generated by transformers, motors, etc., or near devices emitting radio waves, such as transceivers or cellular phones.
- Use of wireless microphone near this unit
When a wireless microphone or wireless microphone tuner is used near this unit during recording, the tuner could pick up noise.
- Avoid using or placing this unit in the following places.
 - Places subject to extreme heat or cold
 - Places with excessive dirt or dust
 - Places with high humidity or moisture
 - Places subject to smoke or vapor such as near a cooking stove
 - Places subject to strong vibrations or unstable surfaces
 - In a parked car under direct sunlight or near a heater for long hours
- Do not place this unit at places that are subject to radiation or X-rays, or where corrosive gases occur.
- Protect this unit from getting wet when shooting on a beach. In addition, salt and sand may adhere to the body. Be sure to clean the unit after use.
- Protect this unit against penetration of dust when using it in a place subject to sandy dust.

| Drip-proof

- This camera recorder has a drip-proof structure equivalent to IPX2 according to our testing method. It is not completely waterproof. And the drip-proof performance under all conditions is not guaranteed.
 - IPX2 (protection rating against dripping water) ensures that when a device is tilted at an angle of 15 degrees to the front, back, right and left with water dripping vertically on it at a rate of 3 mm/min for a total of 10 minutes at 2 minutes 30 seconds for each position, the device will function properly when operated.
- To ensure the drip-proof performance, close the caps and covers fully.
- Avoid heavy rain and heavy water splashes.
- If this camera recorder gets wet and there are water droplets, wipe off with a dry cloth immediately. If the camera recorder is turned upside down or tilted at 15 ° or more while it is wet, water may enter the camera recorder and cause malfunction.
- If this camera recorder gets wet, water may come out from the gaps. Do not carry it while it is wet. Place it on a dry cloth for a while and let it dry.

| Carrying the Camera

- Do not drop or hit this unit against a hard object when transporting.

| Power Saving

- When this unit is not in use, be sure to set the [POWER ON/OFF] switch to "OFF" in order to reduce power consumption.

| Maintenance

- Turn off the power before performing any maintenance.
- Wipe the external cabinet of the unit with a soft cloth. Do not wipe the body with benzene or thinner. Doing so may cause the surface to melt or turn cloudy. When it is extremely dirty, soak the cloth in a solution of neutral detergent, wipe the body with it, and then use a clean cloth to remove the detergent.

Rechargeable Battery

- The batteries recommended for use with this camera recorder are as follows.
U model : Dionic HC, Digital 150 (Anton/Bauer)
E model : E-HL9, DUO-150 (IDX)
- Please make use of one of the recommended batteries.
Heavy batteries may fall off if they are not used correctly.

Regular Inspection (Maintenance)

- Under normal environment, dust will accumulate on the camera recorder when it is used over a long period. Dust may enter the camera recorder especially if it is used outdoors. This may affect the image and sound quality of the camera recorder. Check and replace the fan after every 9000 hours (suggested guideline). You can check the usage time of the fan in [System] → [System Information] → [Fan Hour]. If the fan is used for more than 9000 hours without replacement, "Fan Maintenance Required" will be displayed every time you turn on the power.

LCD Monitor and Viewfinder **CHU CHE**

- The LCD monitor and viewfinder screen are manufactured using high-precision technology. Black spots may appear on the LCD monitor and viewfinder screen, or red, blue, and/or white spots may not disappear. However, this is not a malfunction and these spots are not recorded on the SD card.
- If you use this unit continuously for a long period of time, the characters displayed in the viewfinder may temporarily remain on the screen. This is not recorded on the SD card. They will not appear after you turn the power off and then on again.
- If you use this unit in a cold place, the images may appear to lag on the screen, but this is not a malfunction. Retained images are not recorded on the SD card.
- Do not press against the surface with force or subject it to strong impact. Doing so may damage or break the screens.
- Noise may appear in the viewfinder when switching between the live video and playback images.
- Due to the characteristic of the viewfinder display device, colors may appear on the images when you blink your eyes. It does not affect the recorded images, SDI output, or HDMI output.

Lens

- This camera recorder is an interchangeable lens camera. Please have the interchangeable lens ready before use.
- Read the "INSTRUCTIONS" of the interchangeable lens to be attached to get a full understanding before use.
- Optical performance of lens
Due to the optical performance of the lens, color divergence phenomena (magnification chromatic aberration) may occur at the periphery of the image. This is not a camera malfunction.
- Depending on the lens attached, there are function limitations on the lens with this camera recorder or the lens may not function properly.
- The lens operation sound may be recorded.
- Depending on the lens used, the approximate distance to the subject may not be displayed.
- There can be a large variation in the light intensity during Auto Iris mode, Manual Iris mode and zoom mode.

GPS **CHU CHE**

- The GPS (Global Positioning System) satellites are managed by the Department of State of the U.S., and its precision may be altered intentionally.
- Perform positioning at an unobstructed location with a clear view that is not indoors or blocked by trees.
- The time needed for obtaining the position information may be longer and variation may also be larger depending on the surrounding environment and time of day.
- This camera recorder uses the WGS 84 World Geodetic System.
- Signal from GPS satellites may be interrupted by communication signal from electronic devices such as mobile phones.
- Make use of it in accordance with the regulations of the country, region or location of use.

Encryption in Network Connection

- Wireless LAN connections make use of an encryption function.
This encryption is designed for commercially-sold equipment, and it cannot be altered.

| SDHC/SDXC Cards

- SDHC/SDXC card is referred to as SD card in this manual.
 - This camera recorder saves the recorded images and audio sound on the SD card (sold separately) in the card slot.
 - If the SD card contains files recorded by devices other than this camera recorder or files that are saved from a PC, the recordable time may be shorter or data may not be properly recorded. In addition, the remaining space on the card may not increase even when files are deleted using a PC.
 - For details on the combinations of usable SD card and format setting, refer to [Usable Cards] (P 22).
- * Using cards other than those from Panasonic, TOSHIBA or SanDisk may result in recording failure or data loss.

| Handling of SD Cards

- The status indicator lights up in red when data on the SD card is being accessed. Do not remove the SD card during data access (such as recording, playback, or formatting). Do not turn off the power or remove the battery and AC adapter during access either.
- Do not use or store the SD card in a place that is subject to static electricity or electrical noise.
- Do not place the SD card near locations that are exposed to strong magnetic fields or radio waves.
- Inserting the SD card incorrectly may result in damage of this unit or the SD card.
- We are not liable for any accidental loss of data stored on the SD card. Please back up any important data.
- Make use of the SD card within the prescribed conditions of use.
Do not use it at the following locations.
Places that are subject to direct sunlight, high humidity or corrosion, places near thermal equipment, sandy or dusty places, or in a car under the sun with the doors and windows closed.
- Do not bend or drop the SD card, or subject it to strong impact or vibration.
- Do not splash the SD card with water.
- Do not dismantle or modify the SD card.
- Do not touch the terminals with your hands or with a metal object.
- Do not allow dust, dirt, water, or foreign objects to adhere to the terminals.
- Do not remove the labels or stick other labels or stickers on the SD cards.
- Do not use pencils or ballpoint pens to write on the SD cards. Always use oil-based pens.

- If you format (initialize) the SD card, all data recorded on the card, including video data and setup files, will be deleted.
- You are recommended to use cards that are formatted (initialized) on this camera recorder.
 - The SD card may be damaged if the camera recorder is not operated correctly. Formatting (Initializing) the SD card may allow it to operate correctly.
 - SD cards that have been formatted (initialized) on other cameras, computers or peripheral equipment may not operate correctly. In this case, format (initialize) the SD card on this camera recorder.
- If you want to wipe out all information by completely erasing the data, we recommend either using commercially available software that is specially designed for that purpose, or by physically destroying the SD card with a hammer, etc. When formatting or erasing data using the camera recorder, only the file administration information is changed. The data is not completely erased from the SD card.
- Some commercially available SD cards may be harder to be removed from this unit. Remove them by hooking onto the groove on the cards.
 - It will be easier to remove the cards after several times.
 - Do not stick any stickers on the cards.



- The SD card may pop out when it is being removed. Be careful not to lose the card.

| Copyright

- Any recordings made on this camera recorder that are played back for profit or public preview may infringe on the rights of the owner of the recordings.
Do not use the recordings for purpose other than personal enjoyment without prior consent from the owner. And even for personal enjoyment, you may not be able to record without permission from the owner.

License Notices

- MPEG LA AVC
THIS PRODUCT IS LICENSED UNDER THE AVC PATENT PORTFOLIO LICENSE FOR THE PERSONAL USE OF A CONSUMER OR OTHER USES IN WHICH IT DOES NOT RECEIVE REMUNERATION TO
(i) ENCODE VIDEO IN COMPLIANCE WITH THE AVC STANDARD (“AVC VIDEO”) AND/OR
(ii) DECODE AVC VIDEO THAT WAS ENCODED BY A CONSUMER ENGAGED IN A PERSONAL ACTIVITY AND/OR WAS OBTAINED FROM A VIDEO PROVIDER LICENSED TO PROVIDE AVC VIDEO. NO LICENSE IS GRANTED OR SHALL BE IMPLIED FOR ANY OTHER USE. ADDITIONAL INFORMATION MAY BE OBTAINED FROM MPEG LA, L.L.C. SEE [HTTP://WWW.MPEGLA.COM](http://www.mpegla.com)

- MPEG LA MPEG-2 Patent
ANY USE OF THIS UNIT IN ANY MANNER OTHER THAN PERSONAL USE THAT COMPLIES WITH THE MPEG-2 STANDARD FOR ENCODING VIDEO INFORMATION FOR PACKAGED MEDIA IS EXPRESSLY PROHIBITED WITHOUT A LICENSE UNDER APPLICABLE PATENTS IN THE MPEG-2 PATENT PORTFOLIO, WHICH LICENSE IS AVAILABLE FROM MPEG LA, LLC, 6312 S. WHICH LICENSE IS AVAILABLE FROM MPEG LA, LLC, 6312 S. Fiddlers Green circle, Suite 400E, Greenwood Village, Colorado 80111 U.S.A.

Others

- Do not insert objects other than the memory card into the card slot.
- Do not block the vent on the unit. Blocking of the vent causes internal heating and may lead to burns and fires.
- Do not turn off the [POWER ON/OFF] switch or remove the power cable during recording or playback.
- The camera recorder may not show stable pictures for a few seconds immediately after the power is turned on, but this is not a malfunction.
- When the video signal output terminals are not in use, put on the covers to prevent damage to the terminals.
- Do not drop this unit or subject it to strong impact or vibration as it is a precision equipment.

- Noise may appear in the image when switching modes.
- If placed on its side, heat release efficiency will deteriorate.
- When the connectors that come with connector covers are not in use, put on the covers to prevent damage to the connectors.
- This camera recorder makes use of fonts by Fontworks Inc.
- This camera recorder makes use of M+ FONTS.
- Use the built-in wireless LAN only in the country and region where it was purchased. And there are legal restrictions on the use and outdoor use depending on the country and region. Please be careful not to violate the law. **CHU CHE**

Content of this manual

- All rights reserved by JVC KENWOOD Corporation. Unauthorized duplication or reprinting of this manual, in whole or in part, is strictly prohibited.
- Illustrated designs, specifications and other contents of this manual are subject to change for improvement without prior notice.
- SDXC and SDHC logos are trademarks of SD-3C, LLC.
- The terms HDMI and HDMI High-Definition Multimedia Interface, and the HDMI Logo are trademarks or registered trademarks of HDMI Licensing Administrator, Inc. in the United States and other countries.
- QuickTime, Final Cut Pro, iPhone, iPad, iPod touch, macOS and Safari are trademarks of Apple Inc., registered in the U.S. and other countries.
- iOS is a trademark or registered trademark of Cisco in the U.S. and other countries and is used under license.
- Android and Google Chrome are trademarks and/or registered trademarks of Google LLC.
- QR Code is a registered trademark of Denso Wave Incorporated.
- Microsoft, Windows, and Internet Explorer are either registered trademarks or trademarks of Microsoft Corporation in the United States and/or other countries.
- The company name of Fontworks, Fontworks, and the name of the fonts are registered trademarks of Fontworks Inc.
- Zixi and the Zixi logo are trademarks of Zixi LLC.
- UniSlot is a registered trademark of Ikegami Tsushinki Co., Ltd.
- Other product and company names included in this instruction manual are trademarks and/or registered trademarks of their respective companies. Marks such as ™ and ® have been omitted in this manual.

Specifications

General

Item	Description
Power	When using an external power source: DC 11.0 V to 17.0 V When using a battery: DC 14.4 V (Anton/Bauer, IDX)
Power consumption	Approx. 38 W (during single recording at factory default settings while using the viewfinder) Approx. 33 W (When using only the camera body during single recording at factory default settings)
Mass	CHU : Approx. 5.1 kg (*1) CHE : Approx. 5.2 kg (*1) STU : Approx. 4.3 kg (*2) RCHE : Approx. 4.4 kg (*2)
Allowable operating temperature	0 °C to 40 °C (32 °F to 104 °F)
Allowable operating humidity	30 %RH to 80 %RH
Allowable storage temperature	-20 °C to 50 °C (-4 °F to 122 °F)
Drip-proof performance	Equivalent to IPX2
Built-in wireless LAN	IEEE802.11a/b/g/n/ac (2.4 GHz/5 GHz band) Encryption method: WPA2 CHU CHE

*1 Camera body and Viewfinder

*2 Camera body only

Terminal Section

Video/Audio

Item	Description
[HD/SD SDI IN] terminal	
3G-SDI, HD-SDI	Compliant with SMPTE ST424, Compliant with SMPTE ST292
3G-SDI, HD-SDI embedded audio standard	Compliant with SMPTE ST299, Compliant with SMPTE ST299
[HD/SD SDI OUT 1/2] terminal (480i or 576i: Downconverted 720p/1080i/1080p: embedded audio), BNC (unbalanced)	
3G-SDI, HD-SDI, SD-SDI	Compliant with SMPTE ST424, Compliant with SMPTE ST292, Compliant with SMPTE ST259
3G-SDI, HD-SDI, SD-SDI embedded audio standard	Compliant with SMPTE ST299, Compliant with SMPTE ST299, Compliant with SMPTE ST272

Item	Description
[HDMI] output terminal	Type A
[VIDEO OUT] terminal (BNC)	Composite Video 1.0 V (p-p), 75 Ω (unbalanced)
[VF] terminal	26-pin
[MIC IN] terminal (XLR 5-pin)	-50 dBu, 4 kΩ, XLR (balanced), +48 V output (phantom power supply)
[AUDIO INPUT1/INPUT2] terminal (XLR 3-pin)	
[MIC]	-60 dBu, 4 kΩ, XLR (balanced), +48 V output (phantom power supply)
[LINE]	+4 dBu, 10 kΩ, XLR (balanced)
[AUDIO OUT] terminal (XLR 5-pin)	0 dBu, 100 Ω, XLR (balanced)
[PHONE] terminal	Φ3.5 mm stereo mini jack

Others

Item	Description
[LAN] terminal (RJ-45)	100BASE-TX/1000BASE-T
[HOST] terminal	USB-A type, network connection function only
[REMOTE] terminal	miniDin 6-pin
[TC IN] terminal	1.0 V(p-p) to 4.0 V(p-p) high impedance
[TC OUT] terminal	2.0 ± 1.0 V (p-p) low impedance
[LENS] terminal	12pin
[DC INPUT] terminal	XLR 4-pin
[12V $\overline{=}$ 1.8A] DC OUT terminal (Rear)	4-pin, DC 11.0 V to 17.0 V, 1.8 A
[12V $\overline{=}$ 0.5A] DC OUT (LAN) terminal	4-pin, DC 11.0 V to 17.0 V, 0.5 A
[LIGHT] terminal	D-tap (DC 12 V, max. 50 W)
[GENLOCK] terminal	1.0 V (p-p), 75 Ω
Wireless audio slot	UniSlot 2ch, -40 dBu (balanced)
Expansion slot	For future expansion

Others

Camera Section

Item	Description
Image pickup device	2/3-inch, 2.2 megapixels, progressive CMOS x 3
Lens Mount	2/3-inch B4 Bayonet mount system
Color separation prism	F1.6, 3-color separation prism
Sensitivity	F12, 2000 lx (standard value: 60 Hz)
Sync system	External/Internal Synchronization (Built-in SSG)
ND filter	Clear, 1/4, 1/16, 1/64
Gain	-6 dB, -3 dB, 0 dB, 3 dB, 6 dB, 9 dB, 12 dB, 15 dB, 18 dB, 21 dB, 24 dB, 27 dB, 30 dB, Lolux (24 dB, 30 dB, 36 dB, 42 dB), AGC
Electronic shutter	1/3 to 1/10000, EEI
LCD Monitor	3.5-inch LCD QHD (960 x 540)
Viewfinder CHU CHE	3.26-inch OLED WVGA (854 x 480)

Storage Section

Item	Description
Supported media	SDHC/SDXC
Slots	x 2

Video/Audio

Item	Description
HD mode (MOV: MPEG-2)	
Recording file format	QuickTime File Format
Video	
HQ mode	MPEG-2 Long GOP VBR, 35 Mbps (Max) MP@HL, 1920x1080/59.94i, 29.97p, 50i, 25p 1440x1080/59.94i, 50i 1280x720/59.94p, 50p
SP mode	MPEG-2 Long GOP CBR, 25 Mbps (Max) MP@H14 1440x1080/59.94i, 50i
Audio	LPCM 2ch, 48 kHz/16 Bit

Item	Description
HD mode (MOV: H.264)	
Recording file format	QuickTime File Format
Video	
XHQ 422 10-bit mode	MPEG-4 AVC/H.264, 50 Mbps (Max) 1920x1080/59.94p, 59.94i, 29.97p, 50p, 50i, 25p 1280x720/59.94p, 50p
XHQ mode	MPEG-4 AVC/H.264, 50 Mbps (Max) 1920x1080/59.94p, 59.94i, 29.97p, 50p, 50i, 25p
UHQ mode	MPEG-4 AVC/H.264, 35 Mbps (Max) 1920x1080/59.94i, 29.97p, 50i, 25p 1280x720/59.94p, 50p
Audio	LPCM 2ch/4ch, 48 kHz/16 Bit, 24 Bit (422 10bit only)
Streaming Mode	1920x1080 (59.94p/50p) AAC128 k 24/20/16/12/8 Mbps 1920x1080(59.94i/50i/29.97p/25p) AAC128 k 20/16/12/8/5/3 Mbps 1280x720(59.94p/50p) AAC128 k 20/16/12/8/5/3 Mbps 1280x720 (29.97p/25p) AAC128 k 8/5/3/1.5 Mbps

Dimensional Outline Drawing (Unit: mm)

Wireless LAN antenna and viewfinder are not included in GY-HC900STU and GY-HC900RCHE.

For U Model

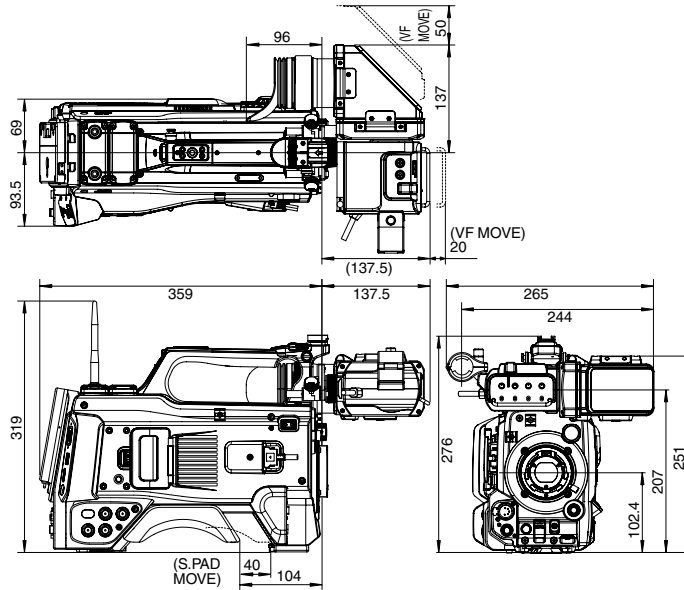

For E Model

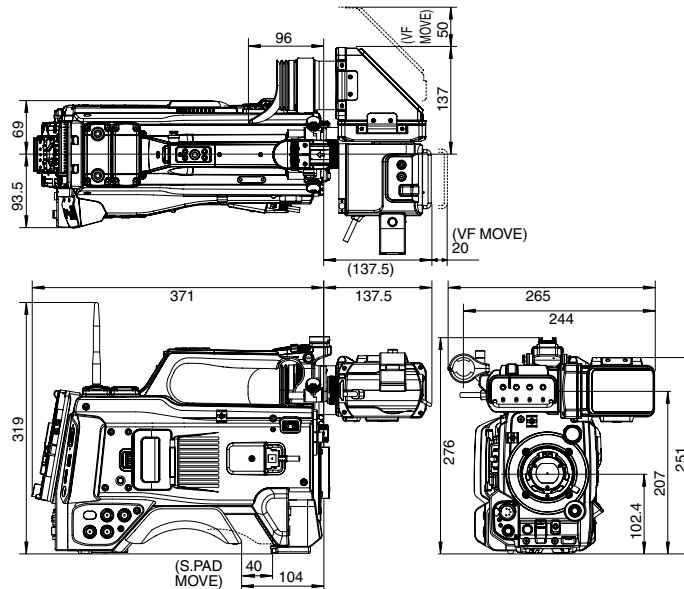

* The specifications and appearance of this product are subject to changes for further improvement without prior notice.

Others

Software License Agreement

The software embedded in the Product (hereinafter the “Licensed Software”) provided by JVC KENWOOD Corporation (hereinafter the “Licensor”) is copyrighted to or sublicensable by the Licensor, and this Agreement provides for the terms and conditions which Users shall follow in order to use the Licensed Software. The User shall use the Licensed Software by agreeing with the terms of this Software License Agreement. This Agreement shall be deemed completed at the time the User (hereinafter the “User”) initially used the Product in which the “Licensed Software” is embedded.

The Licensed Software may include the software which has been licensed to the Licensor directly or indirectly from any third party. In such case, some third parties require the Users to follow their conditions for use separately from this Software License Agreement. Such software shall not be subject to this Agreement, and the Users are urged to read the “Important Notice concerning the Software” to be provided separately.

Article 1 General Provision

The Licensor shall grant to the User a non-exclusive and non-transferable (other than the exceptional case referred to in Article 3, Paragraph 1) licensed to use the Licensed Software within the country of the User (the country where the User bought the Product (hereinafter the “Country”).

Article 2 License

1. The license granted under this Agreement shall be the right to use the Licensed Software in the Product.
2. The User shall not duplicate, copy, modify, add, translate or otherwise alter, or lease the Licensed Software and any related documents, whether in whole or in part.
3. The use of the Licensed Software shall be limited to personal purpose, and the Licensed Software shall not be distributed, licensed or sub-licensed whether it is for commercial purpose or not.
4. The User shall use the Licensed Software according to the directions described in the operation manual or help file, and is prohibited to use or duplicate any data in a manner violating the Copyright Law or any other laws and regulations by applying whole or a part of the Licensed Software.

Article 3 Conditions for Grant of License

1. When the User transfers the Product, it may also transfer the license to use the Licensed Software embedded in the Product (including any related materials, updates and upgrades) on condition that no original, copies or related materials continue in the possession of the User, and that the User shall cause the transferee to comply with this Software License Agreement.

2. The User shall not carry out reverse engineering, disassembling, decompiling or any other code analysis works in connection with the Licensed Software.

Article 4 Right pertaining to the Licensed Software

1. Any and all copyrights and other rights pertaining to the Licensed Software and related documents shall belong to the Licensor or the original holder of the right who granted to the Licensor the license or sublicense for the Licensed Software (hereinafter the “Original Rightholder”), and the User shall not be entitled to any right other than the license granted hereunder, in respect of the Licensed Software and any related documents.
2. The User shall, whenever the User uses the Licensed Software, comply with any laws relating to the copyright and other intellectual property rights.

Article 5 Indemnification of Licensor

1. Neither the Licensor nor the Original Rightholder shall be liable for any damage incurred by the User or any third party due to the exercise of the license granted to the User under this Agreement, unless otherwise restricted by law.
2. The Licensor will offer no guarantee for the merchantability, convertibility and consistency with certain objective of the Licensed Software.

Article 6 Liability to Third Party

If any dispute has arisen with any third party due to an infringement upon a copyright, patent or any other intellectual property right that was caused by the User’s use of the Licensed Software, the User shall settle such dispute at the User’s own cost and hold the Licensor and the Original Rightholder harmless from any inconvenience it may cause.

Article 7 Confidentiality

The User shall keep the confidentiality of such portion of the Licensed Software, related documents thereof or any other information to be granted under this Agreement, as well as the conditions of this Agreement as has not yet entered the public domain, and shall not disclose or divulge the same to any third party without approval of the Licensor.

Article 8 Termination

In case the User falls under any of the events described in the following items, the Licensor may immediately terminate this Agreement or claim that the User compensates for the damage incurred by the Licensor due to such event:

- (1) when the User violated any provision of this Agreement; or
- (2) when a petition has been filed against the User for an attachment, provisional attachment, provisional disposition or any other compulsory execution.

Article 9 Destruction of the Licensed Software

If this Agreement is terminated pursuant to the provision of Article 8, the User shall destroy the Licensed Software, any related documents and copies thereof within two (2) weeks from such date of termination.

Article 10 Export Restriction

1. The User shall understand that the Licensed Software shall be subject to the export restrictions adopted by the country of User and any other countries.
2. The User shall agree that the software will be subject to any and all applicable international and domestic laws including the export control regulation of the country of User and any other countries, and any restrictions concerning the end-users, the use by end-users and importing countries to be provided by the country of User and any other countries, and any other governmental authorities.
3. If the User is an agency of the United States of America (the "Government"), the User acknowledge Licensor's representation that the Licensed Software is a "Commercial Item" as defined in Federal Acquisition Regulation (FAR) part 2.101(g) consisting unpublished "Commercial Computer Software" as those items are used at FAR part 12.212 and is only license the User with the same use right Licensor grants all commercial end users pursuant to the terms of this Agreement.

Article 11 Miscellaneous

1. In the event any part of this Agreement is invalidated by operation of law, the residual provisions shall continue in force.
2. Matters not stipulated in this Agreement or any ambiguity or question raised in the construction of this Agreement shall be provided or settled upon good-faith consultation between the Licensor and the User.
3. The Licensor and the User hereby agree that this Agreement is governed by the laws of Japan, and any dispute arising from, and relating to the rights and obligations under, this Agreement shall be submitted to the exclusive jurisdiction of the Tokyo District Court for its first instance.

Important Notice concerning the Software

Software License Attached to the Product :

The Software embedded in the Product is composed of several independent software components, and in each of such individual components (hereinafter the "Licensed Software"), a copyright of either JVC KENWOOD Corporation (hereinafter "JKC") or a third party subsists.

The Product uses the software component designated in the End-User License Agreement that was executed between JKC and a third party (hereinafter "EULA"). The Licensed Software covers those corresponding to free software, and, as a condition of distribution of the software component in executable format which is based on the license granted under the GNU General Public License or Lesser General Public License (hereinafter "GPL/LGPL"), it requires an availability of the source code for the relevant component. Please refer to the following URL concerning the distribution of the source code;

<http://www3.jvckenwood.com/english/download/gpl/index.html>

Please note that we are unable to answer any inquiry relating to the contents, etc. of the source code. In addition, the Licensed Software includes the software developed or created independently by JKC and there exists an ownership of JKC in such software and any accompanying documents, which is protected by the Copyright Law, any international treaties and other applicable laws. As to matters concerning the handling by JKC of the software components, please refer to the "Software License Agreement" attached hereto. Please note that any software component licensed under "EULA" which is not subject to "GPL/LGPL", and those developed or created independently by JKC shall not be subject to the requirement for provision of the source code. The software component distributed under "GPL/LGPL" shall be licensed to users without charge, and, therefore, no warranty is given for such software component, either express or implied, within the scope of the applicable laws and regulations. Unless otherwise permitted by applicable laws and regulations or agreed in written form, none of the owners of the copyright or persons entitled to alter or redistribute the software component under the said license shall have any liability for any type of damage or loss resulting from the use of or inability to use such software component. For further details of the conditions of use of such software component or matters required to be complied with, please refer to the relevant "GPL/LGPL". Users are urged to read the details for the relevant license carefully before using the software component covered by "GPL/LGPL" and embedded in the Product. Since the terms and conditions of individual licenses are provided by parties other than JKC, the original English version will be displayed by the Product.

- ① Turn on the power.
- ② Press the [MENU/THUMB] button.
- ③ Select [Main Menu] → [System] → [System Information] → [Open Source License].

GY-HC900CHU/GY-HC900CHE
GY-HC900USTU/GY-HC900RCHE
HD MEMORY CARD CAMERA RECORDER

JVC