

SMD Antenna

Type: WXA-N1SF

Application

High-band specification

No.	Item	Page
1	Dimension/Terminal array/Recommended land pattern	2
2	Power feeding to antenna	3-4
3	Conditions of GND (parts, signaling line, voltage source) placement	5-6
4	Relation between antenna test board and external metal plate	7
5	Measured data of antenna characteristics of minimum size evaluation board	8-15

1. Dimension/Terminal Array/Recommended Land Pattern

•Dimension (in mm)

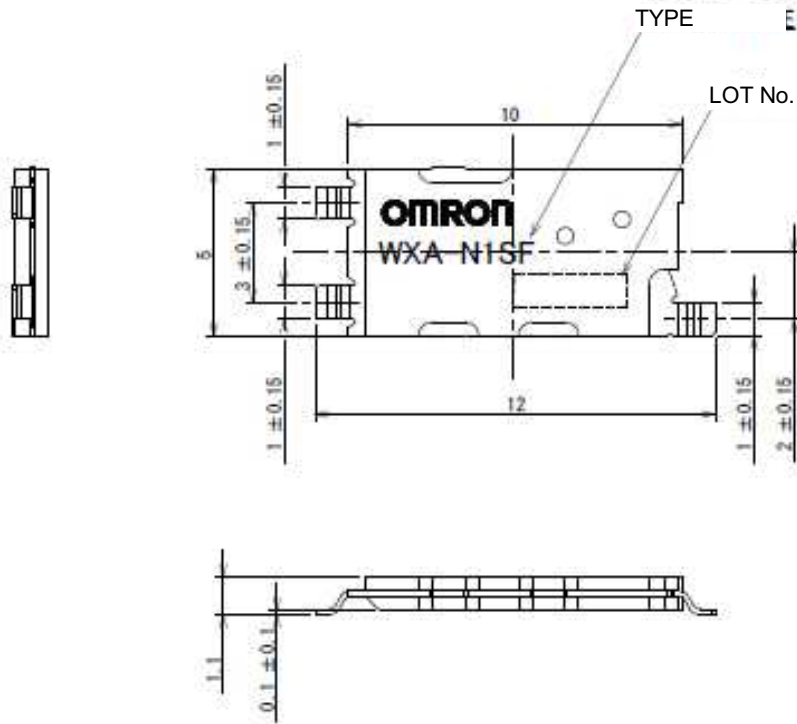

NOTE. TOLERANCE ±0.3 mm

•Terminal array

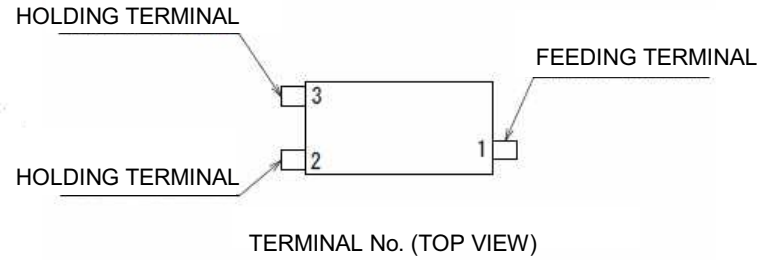

•Recommended land pattern

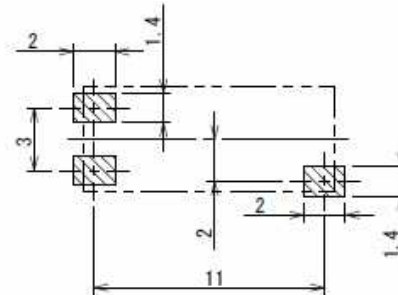

Recommended land pattern SCALE 3:1 TOLERANCE ±0.05

2. Power feeding to Antenna

Example of a microstripline

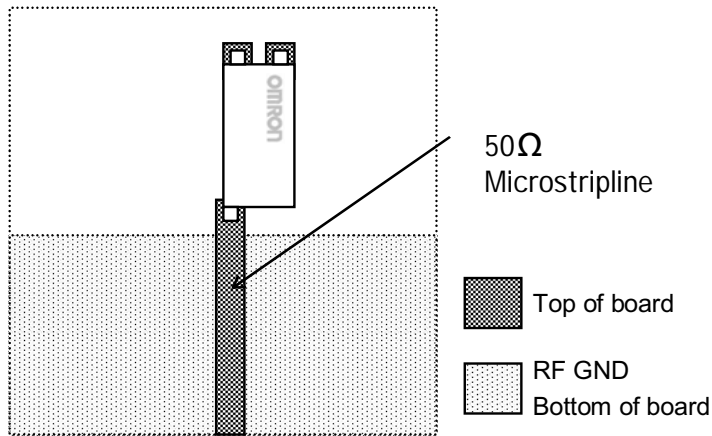

Example of a coplanar waveguide with GND

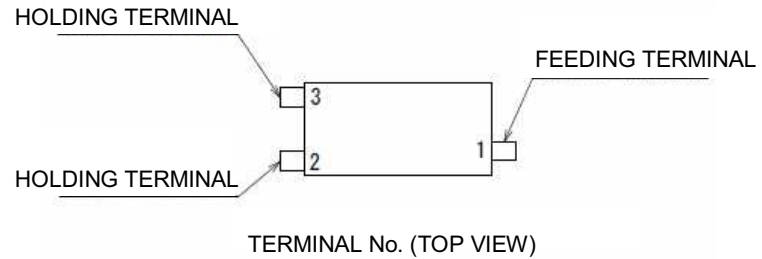
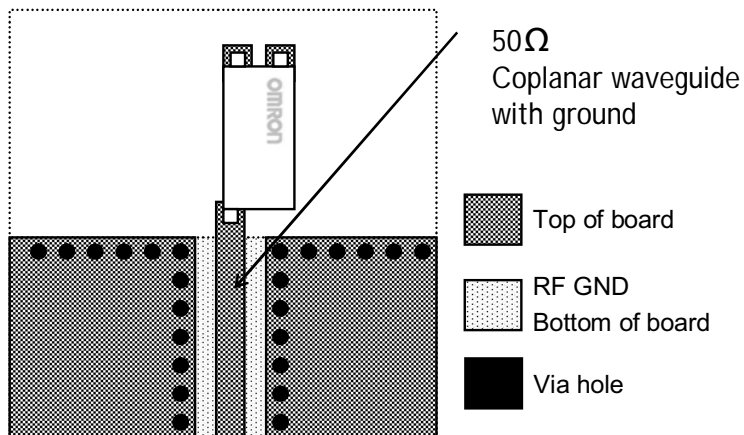

Notes:

A power feeding line may be a microstripline, coplanar waveguide with GND, etc.

Board design must be conducted in a way that voltage is supplied via a terminal No. 1 and the characteristic impedance at a power feeding line is 50Ω .

This characteristic impedance is determined depending on the board thickness, board permittivity, line width, etc.

In a coplanar waveguide with GND, GNDs at the Top of board and bottom of board must be connected by means of via holes near the edge.

Any number of via holes must be created, keeping a distance between via holes to be 1cm or shorter on the FR4 board.

Terminal No. 2 and No. 3 must be soldered to fix the antenna. Don't connect GND, signaling line and power source to terminal No.2 and No.3.

2. Power feeding to Antenna

Example of Microstrip with pad and line-gap for mounting chip element.

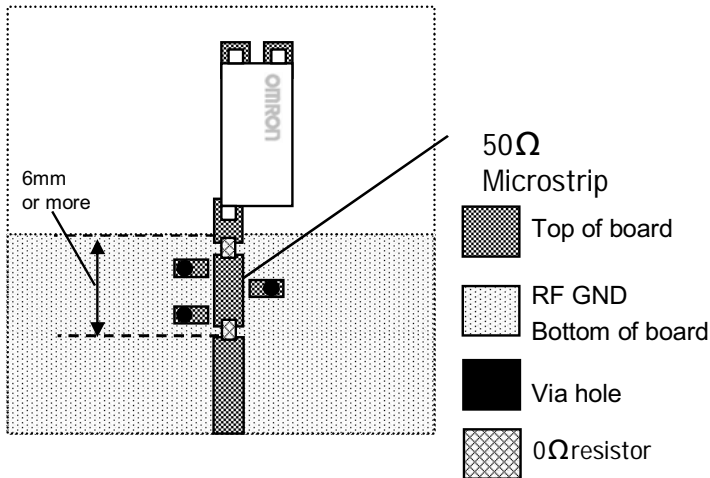

Example of coplanar waveguide with GND with line-gap for mounting chip element.

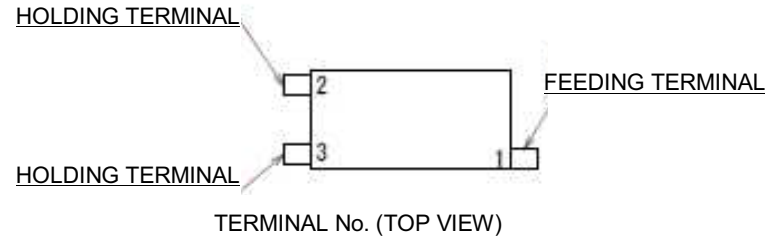
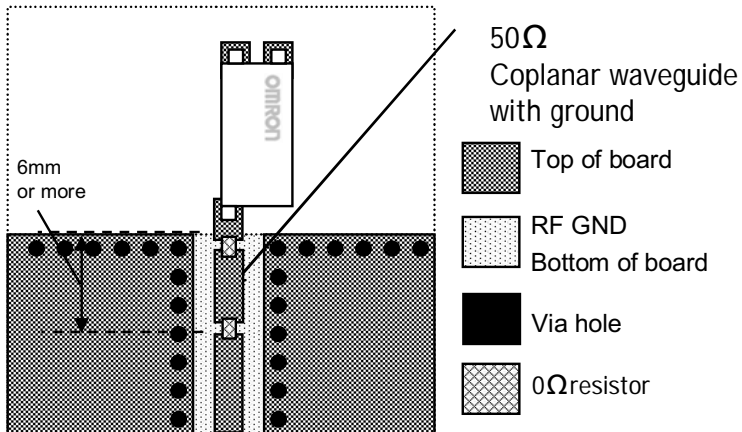

Notes :

For tuning antenna characteristics , at least 1 pad or line-gap for mounting chip LC can be add on around line.

Initially 0Ω-resistor has been mounted on line gap . In turning , 0Ω resistor has been replaced to chip LC having adequate value.

When 2 line-gap have been separated about half wavelength , user can select better turning point from those.

3. Conditions of GND (Parts, Signaling Line, Voltage Source) Placement

Notes:

The antenna characteristics (VSWR, radiation pattern) of the WXA-N1SL antenna vary depending on the relative position between the GND shape of the board and the antenna.

To ensure good antenna characteristics on actual board, proper positioning and wiring are necessary.

The following GND design shows basic requirements for permitting or inhibiting GND (parts, signaling line, voltage source) placement for reference data on experiment with a WXA-N1SL antenna installed on the board.

Be sure to mount the parts, signaling line and voltage source in the area that is shown as GND plane.

The characteristic "VSWR" may deteriorate depending on the GND (parts, signaling line, voltage source) placement conditions and the transmission line length for the antenna.

The listed characteristic data may vary on actual board because this data is measured by using evaluation test board. Finally, be sure to check the characteristics on actual board.

When a power feeding line is short or a GND pattern does not shown in this document, the characteristics of the antenna may not deteriorate even under implementation conditions.

Please contact us to verify or improve antenna performance.

3. Conditions of GND Placement

Restrictions on GND Placement

Notes:

Do not place GND as below as the antenna characteristics will deteriorate resulting in lower performance.

Please contact us for assistance with GND placement.

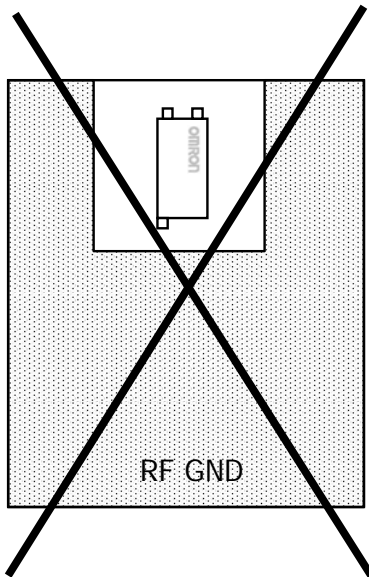

Case with three sides surrounded by GND

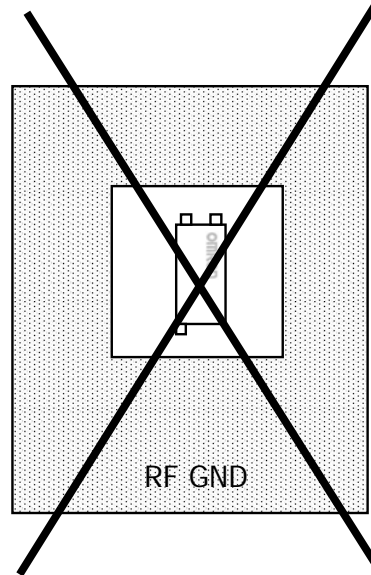

Case with four sides surrounded by GND

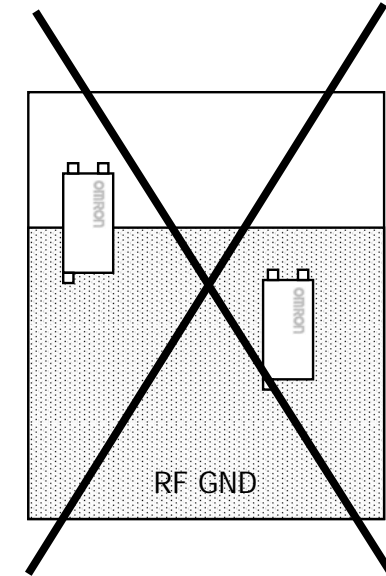

Case with an antenna installed in GND

4. Relation between Antenna Test Board and External Metal Plate

Notes:

When a metal plate is placed near an antenna, it affects the antenna characteristics.

In such a case, maintain a desirable distance, referring to the illustration below.

However, antenna characteristics may not deteriorate depending on overall equipment conditions.

Please contact us whenever you cannot place GND as shown below.

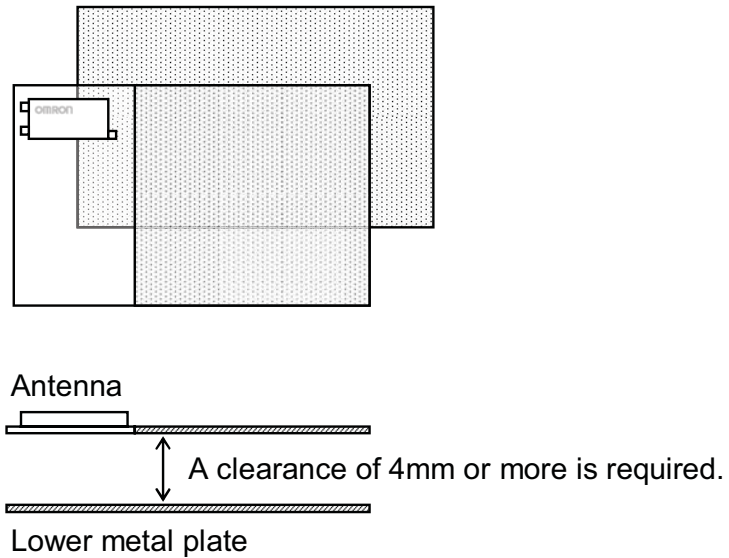

5. Measured Data of Antenna Characteristics of Minimum Size Evaluation Board

Dimension (Board and land dimensions)
(in mm)

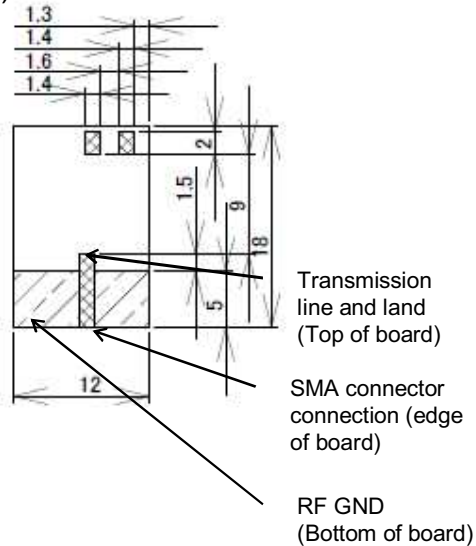

Dimensions
(Antenna installation location)

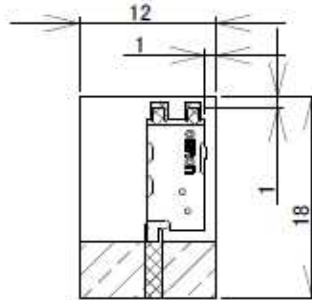

Appearance (Photo)

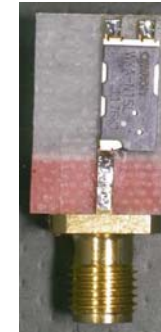

Notes:

The dimensions of this standard size evaluation board assume the shape of a compact flash card (one of the typical applications).

This standard evaluation board has a microstripline having a characteristic impedance of 50Ω and is connected to the SMA connector from the land via the transmission line.

A radiation pattern is measured in the Omron's anechoic chamber with a power feeding cable connected to the SMA connector of the standard size evaluation board.

Item	Value
Transmission line	Microstripline
Board material	FR4
Board thickness	0.8 mm
Signaling line, GND thickness	0.018 mm

5. Measured Data of Antenna Characteristics of Minimum Size Evaluation Board

Electrical Characteristics

Item	Value
Range of frequency (GHz)	5.0 to 9.6
VSWR	3.0 (Max)
Input impedance (Ω)	50
Polarization	Linear

VSWR

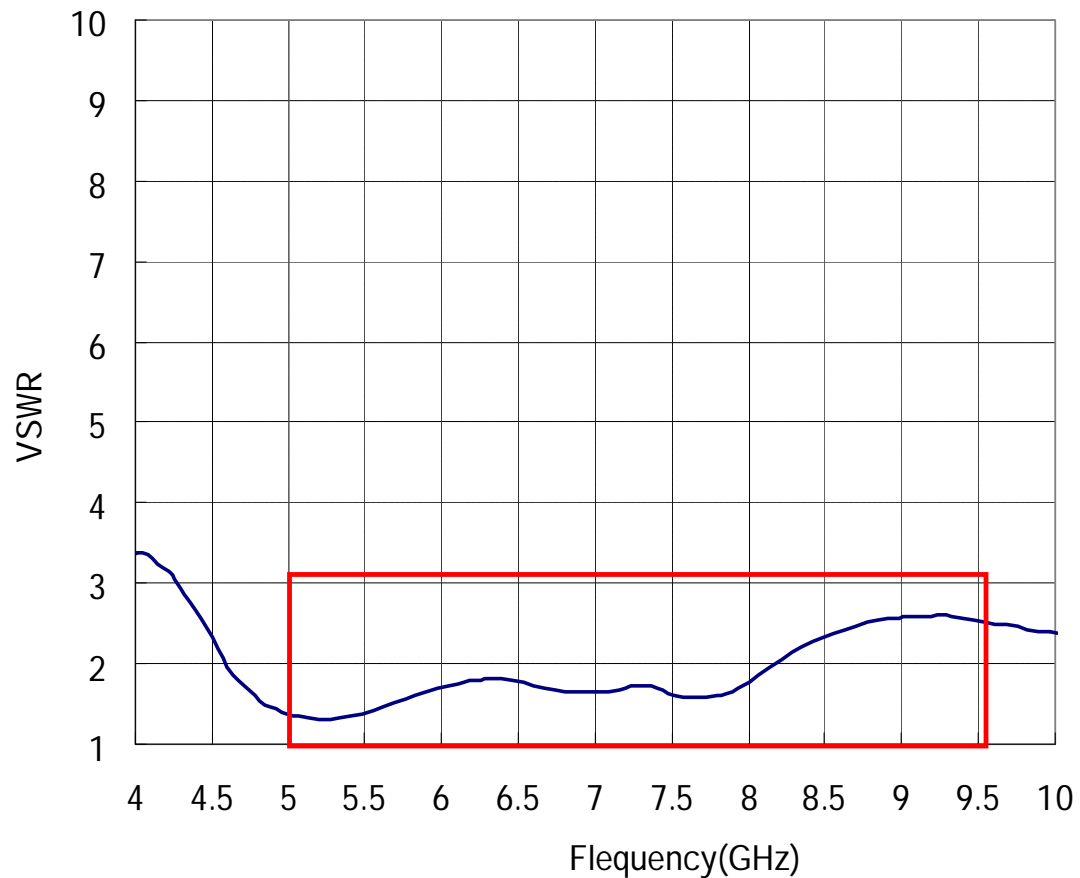

VSWR is 2.6 at maximum in a frequency band from 5.0 to 9.6 GHz.

5. Measured Data of Antenna Characteristics of Minimum Size Evaluation Board

Radiation pattern (dBi)

ZY-plane

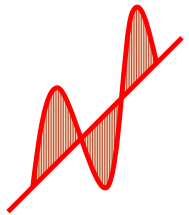
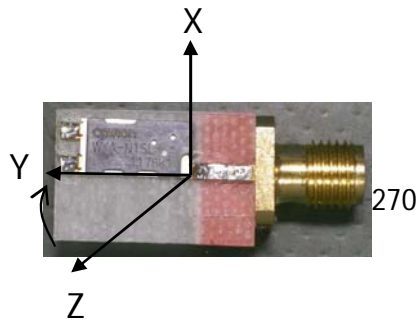

Vertical (V)

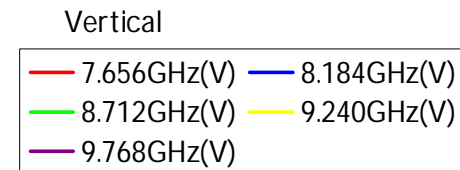
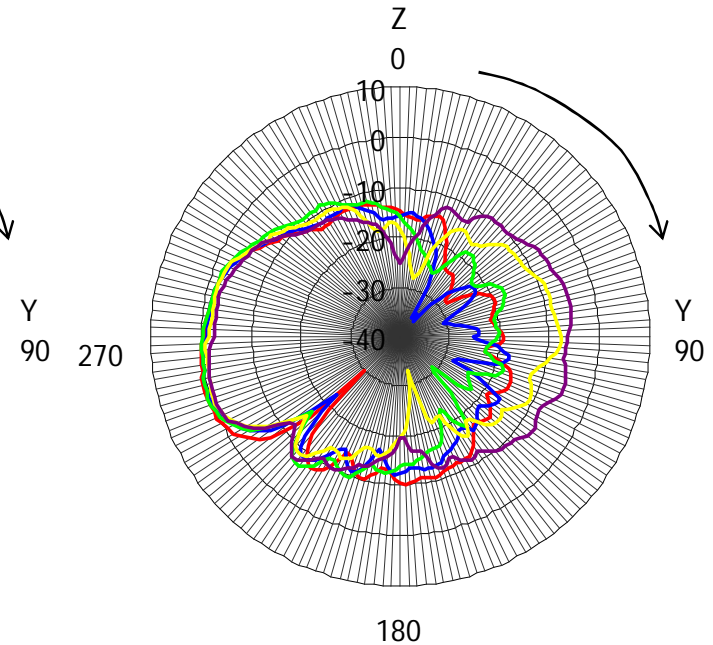
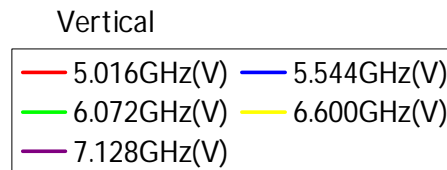
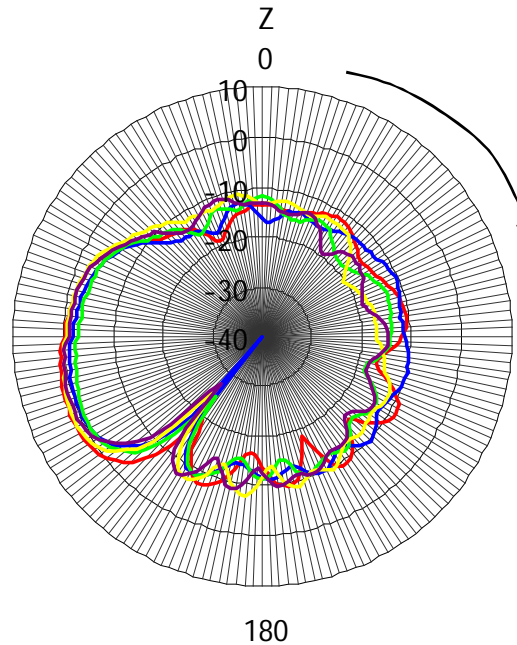

5. Measured Data of Antenna Characteristics of Minimum Size Evaluation Board

Radiation pattern (dBi)

ZY-plane

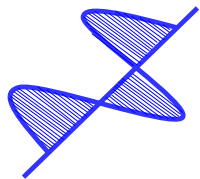
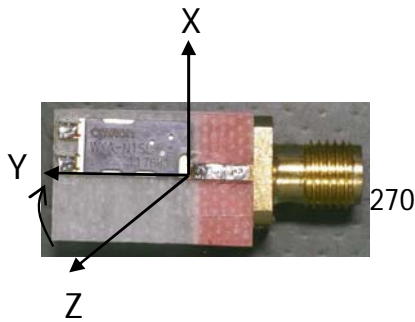

Horizontal (H)

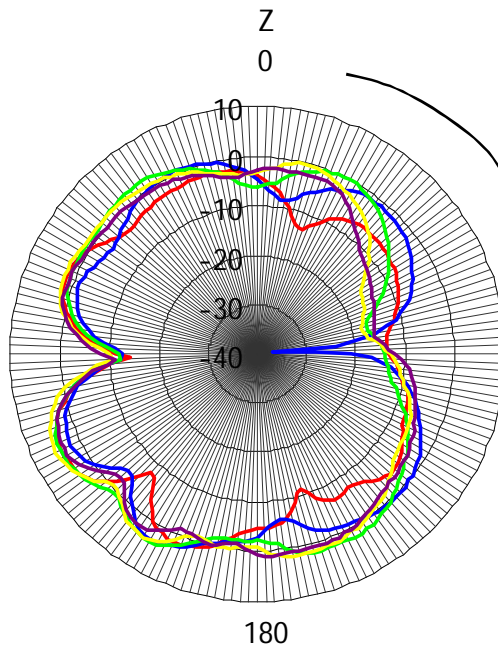

Horizontal

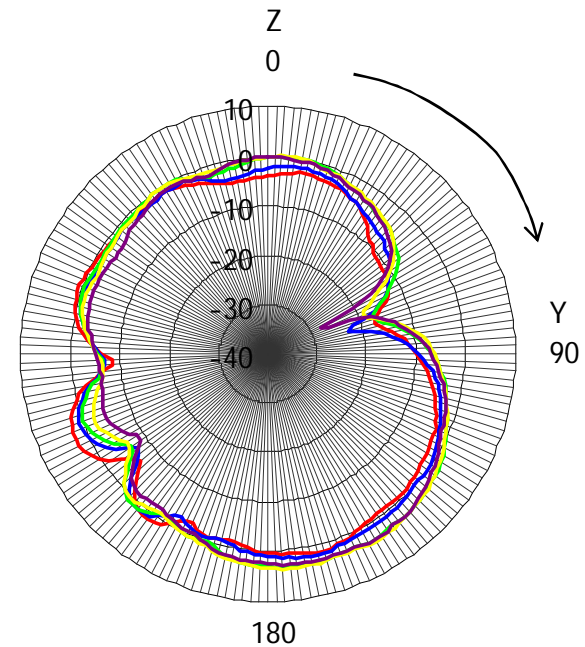
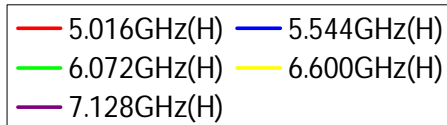

Horizontal

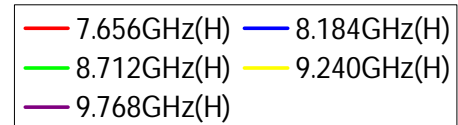

5. Measured Data of Antenna Characteristics of Minimum Size Evaluation Board

• Radiation pattern (dBi)

ZX-plane

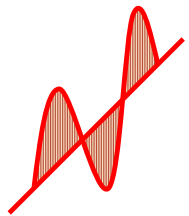
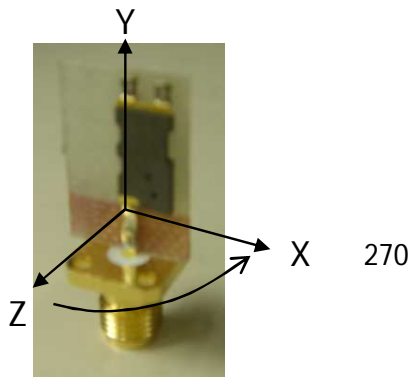

Vertical (V)

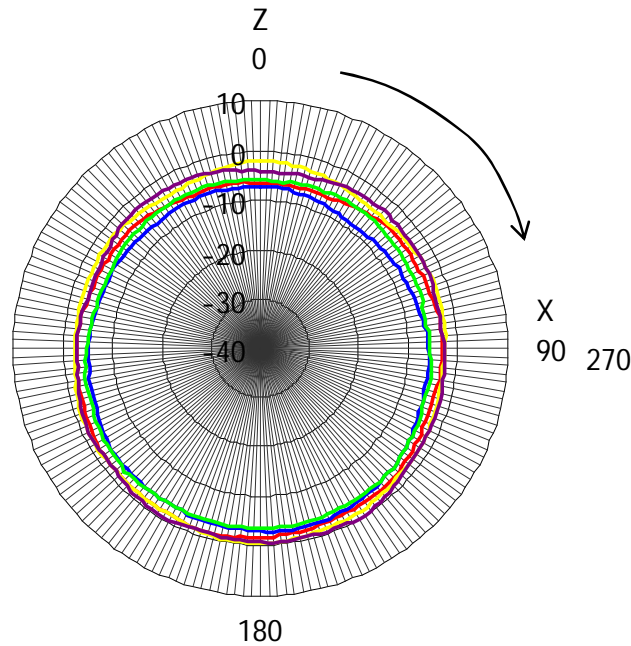

Vertical

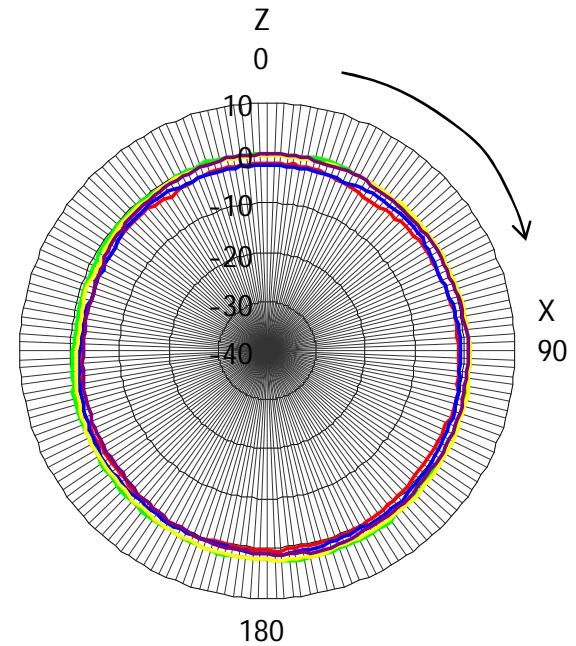
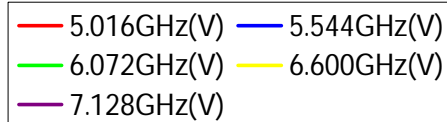

Vertical

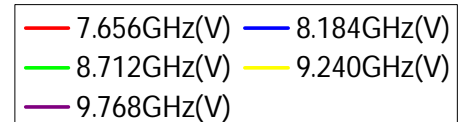

5. Measured Data of Antenna Characteristics of Minimum Size Evaluation Board

• Radiation pattern (dBi)

ZX-plane

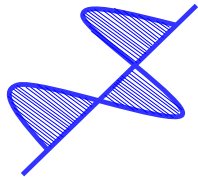
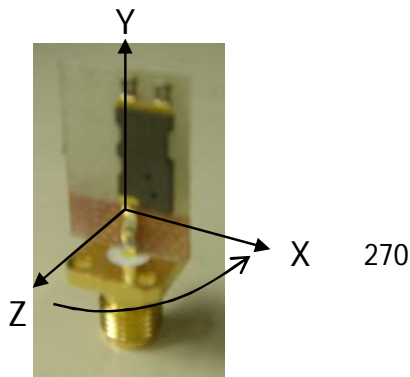

Horizontal (H)

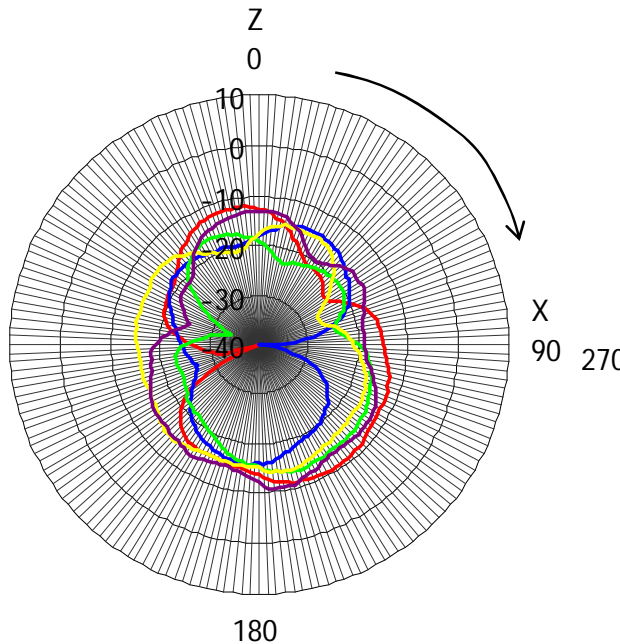

Horizontal

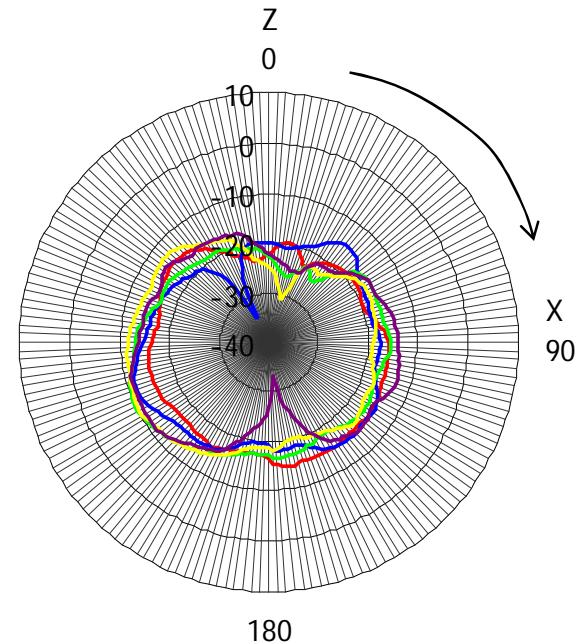
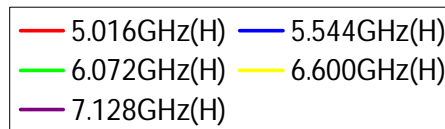

Horizontal

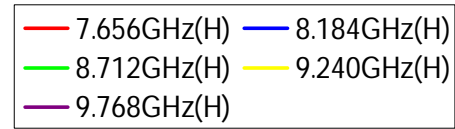

5. Measured Data of Antenna Characteristics of Minimum Size Evaluation Board

- Radiation pattern (dBi)
- XY-plane

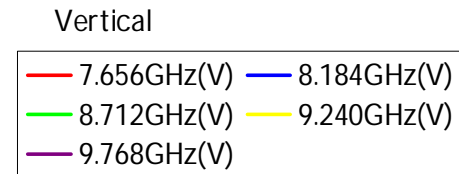
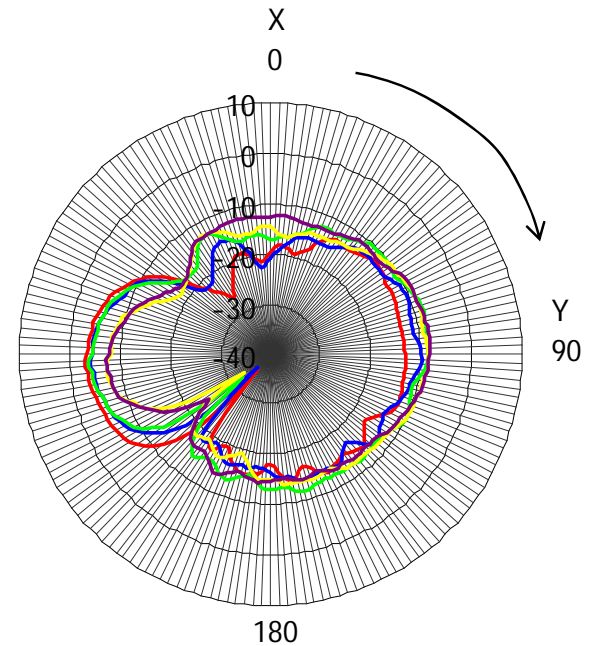
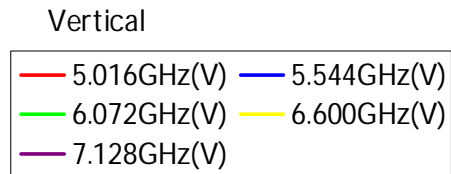
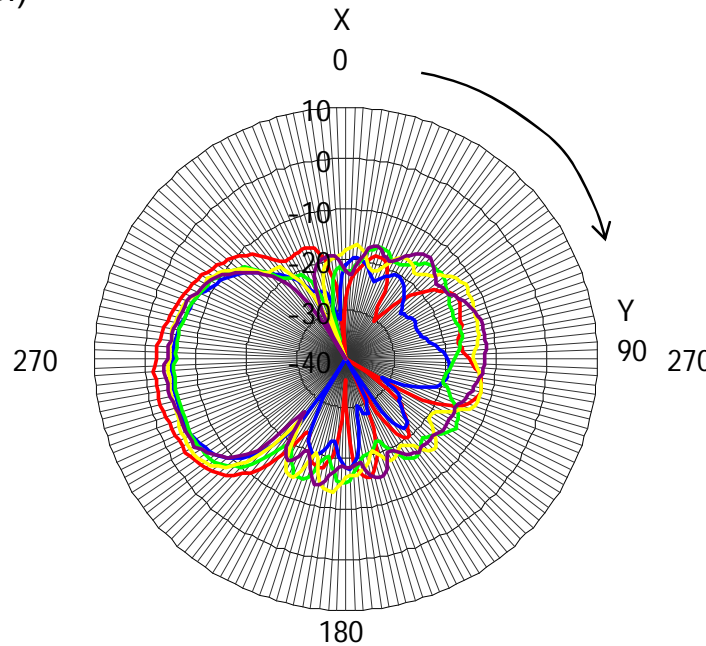
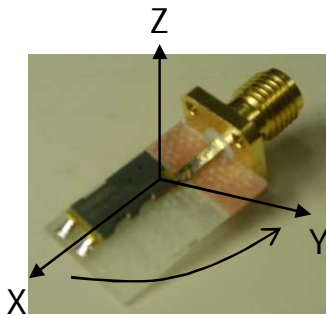

5. Measured Data of Antenna Characteristics of Minimum Size Evaluation Board

- Radiation pattern (dBi)
- XY-plane

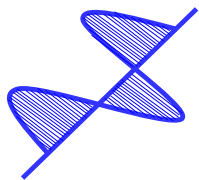
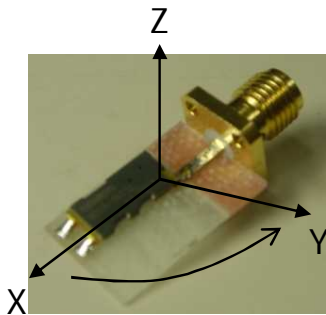

Horizontal (H)

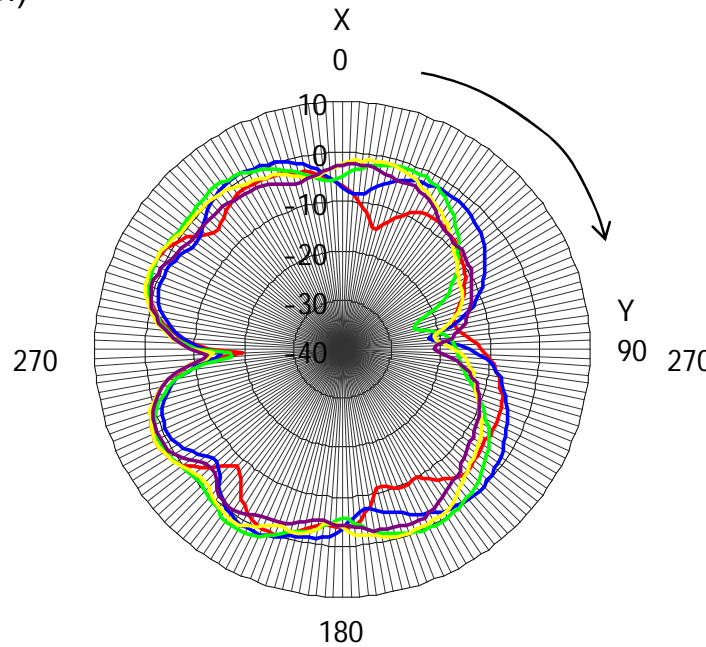

Horizontal

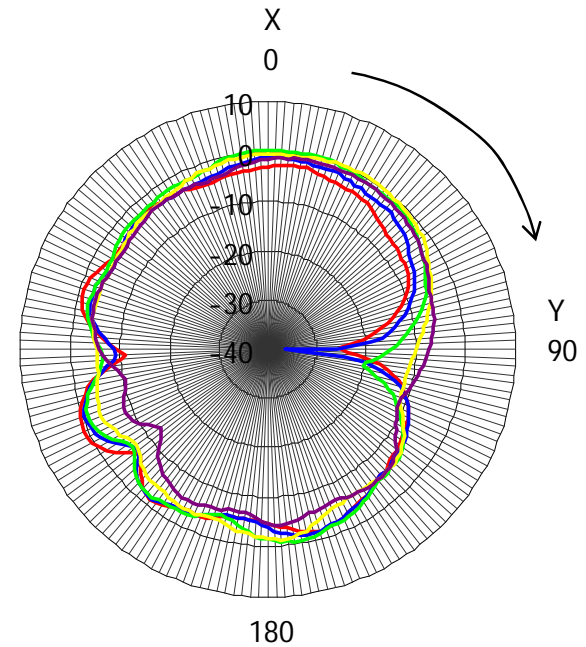
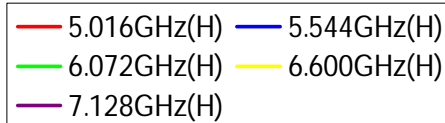

Horizontal

