



Excellence in Compliance Testing

Certification Exhibit

FCC ID: U9O-RF200A

IC: 7084A-RF200A

FCC Rule Part: 15.247

IC Radio Standards Specification: RSS-210

ACS Project Number: 13-2096

Manufacturer: Synapse Wireless, Inc.

Model: RF200A

User Manual

DATA SHEET

RF Engine[®] 200A Series

Model Number: RF200A

Part Numbers: RF200APD1 and
RF200APF1

Document Revision v2.0



Wireless Technology to Control and
Monitor Anything from Anywhere™

© 2013 Synapse, All Rights Reserved
All Synapse products are patented or patent pending
Specifications are subject to change without notice – confirm that data is current
Synapse, the Synapse logo, SNAP, and Portal are all registered trademarks of
Synapse Wireless, Inc.
500 Discovery Drive
Huntsville, Alabama 35806
877-982-7888

Doc # 430133-01D

This Page Intentionally Blank

Table of Contents

1.0 RF200APD1/RF200APDF1 OEM Module Overview	5
1.1 Specifications	6
1.2 Module Pin Definitions	7
1.3 Electrical Characteristics	8
1.4 Mechanical Drawings.....	9
1.5 Board Mounting Configurations.....	9
1.6 Ordering Information.....	10
2.0 Agency Certifications.....	10
2.1 United States (FCC)	10
2.1.1 OEM Labeling Requirements	11
2.1.2 FCC Notices	11
2.1.3 FCC Approved Antennas.....	12
2.2 Canada (IC).....	13
2.2.1 OEM Labeling Requirements.....	14

1.0 RF Engine 200A Series OEM Modules Overview

The RF Engine 200A Series (Model Number RF200A) is an IEEE 802.15.4, low power, highly-reliable solution to embedded wireless control and monitoring network needs that require high data rates. The RF200A embeds Synapse's SNAP OS, the industry's first Internet-enabled, wireless mesh network operating system into the Atmel ATmega128RFA1 single-chip AVR® microcontroller with an integrated transceiver that delivers up to 2Mbps/sec. These low-cost modules can have a range of up to three miles and power consumption as low as 1.4 μ A to enable a new generation of battery-driven systems.

SNAP's on-board Python interpreter provides for rapid application development and over-the-air programming, while Atmel's low-power RF single-chip design saves board space and lowers the overall Bill of Materials and power consumption. The RF200A is approved as an FCC Part 15 unlicensed, modular, transmitter. The modules provide up to 16 channels of operation in the ISM 2.4GHz frequency band. The RF200A module contains both a power amplifier for transmission and a low noise amplifier in the receive path for extended range.

This Data Sheet details Part Numbers RF200APD1 and RF200APF1:

- 20 GPIO and up to 7 A/D inputs
- 128k flash, 58.5k free for over-the-air uploaded user apps
- Two UART ports for control or transparent data which surmounts noisy environments
- Low power modes: 1.5 μ A with internal timer running
- Spread spectrum (DSSS) technology
- Socket-able or solder-able
- Up to 2 Mbps Data Rate
- 2.4 GHz RF Frequency
- Spread Spectrum (DSSS) technology
- Receive Amplifier (12.5 dBm) standard
- Transmit amplifier (18.76 dBm) for best-in-class range
- RF200APD1: SMA antenna (2 miles LoS at 250Kbps)
- RF200APF1: F-Antenna (2 miles LoS at 250Kbps)

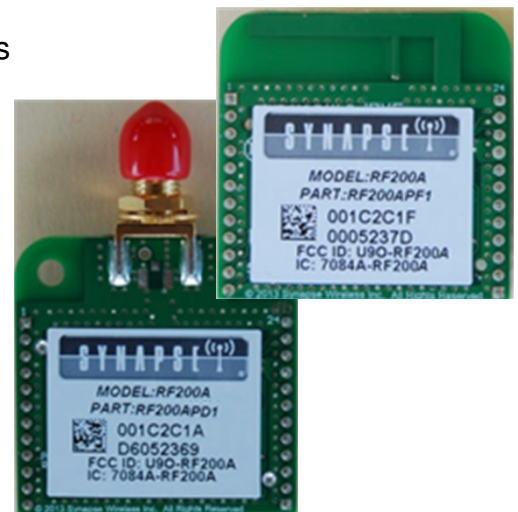

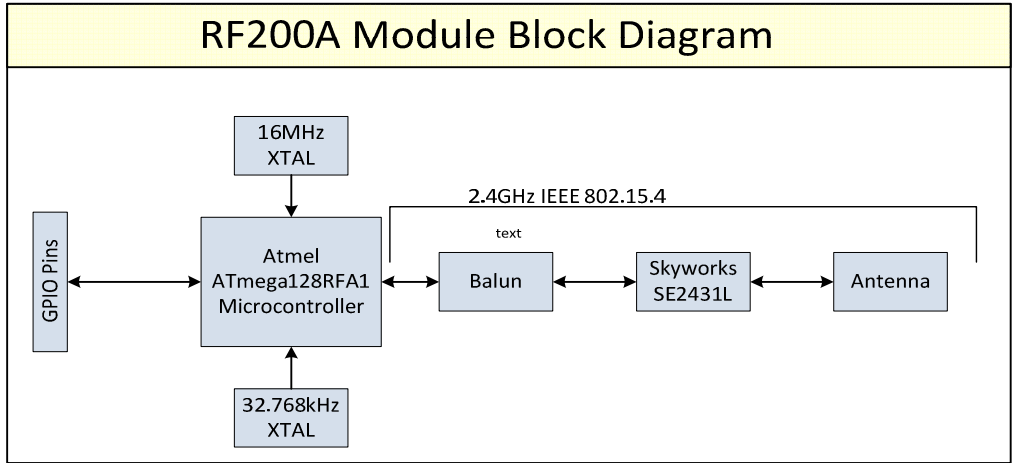

Figure 1.0 Block diagram showing the major subsystems comprising the RF200A

1.1 Specifications

Table 1.0. RF200APD1 / RF200APF1 Specifications		
Performance	Outdoor LOS Range	Up to 2 miles at 250 Kbps
	Transmit Power Output	18.76 dBm
	RF Data Rate	250Kbps, 500Kbps, 1Mbps, 2Mbps
	Receiver Sensitivity	-103 dBm (1% PER)
Power Requirements	Supply Voltage	2.7 - 3.6 V
	Transmit Current (Typ@3.3V)	92mA
	Idle/Receive Current (Typ@3.3V)	23mA
	Power-down Current (Typ@3.3V)	1.4uA
General	Frequency	ISM 2.4 GHz
	Spreading Method	Direct Sequence (DSSS)
	Modulation	O-QPSK
	Dimensions	1.333" x 1.333"
	Operating Temperature	- 40 to 85 deg C.
	Antenna Options	RF200APD1: External RPSMA RF200APF1: F- antenna
Networking	Topology	SNAP
	Error Handling	Retries and acknowledgement
	Number of Channels	16
Available I/O	UARTS with HW Flow Control	2 Ports - 8 total I/O
	GPIO	20 total; 7 can be analog-in with 10bit ADC
Agency Approvals	FCC Part 15.247	FCC ID: U9O-RF200A
	Industry Canada (IC)	IC: 7084A-RF200A
	CE available as a custom part. Call 1-877-982-7888.	

1.2 Module Pin Definitions

Table 1.1. RF200APD1 / RF200APF1 Module Pin Assignments		
Pin	Name	Description
1	GND	Power Supply
2	GPIO0/OC0A/OC1C/PCINT7/PB7	GPIO_0, PWM, or Interrupt
3	GPIO1/OC1B/PCINT6/PB6	GPIO_1, PWM, or Interrupt
4	GPIO2/OC1A/PCINT5/PB5	GPIO_2, PWM, or Interrupt
5	GPIO3/RXD0/PCINT8/PE0	GPIO_3, Interrupt, or UART0 Data Input
6	GPIO4/TXD0/PE1	GPIO_4, UART0 Data Output
7	GPIO5/OC3B/INT4/PE4	GPIO_5, PWM, Interrupt, or UART0 CTS Output
8	GPIO6/OC3C/INT5/PE5	GPIO_6, PWM, Interrupt, or UART0 RTS Input
9	GPIO7/RXD1/INT2/PD2	GPIO_7, Interrupt, or UART1 Data Input
10	GPIO8/TXD1/INT3/PD3	GPIO_8, Interrupt, or UART1 Data Output
11	GPIO9/ICP1/PD4	GPIO_9, or UART1 CTS Output
12	GPIO10/ICP3/INT7/CLK0	GPIO_10, Interrupt, Clock Output, or UART1 RTS Input
13	GPIO11/ADC0/PF0	GPIO_11, or Analog In
14	GPIO12/ADC1/PF1	GPIO_12, SPI MOSI, or Analog In
15	GPIO13/ADC2/DIG2/PF2	GPIO_13, SPI SCLK, Antenna Diversity, or Analog In
16	GPIO14/XCK0/AIN0/PE2	GPIO_14, SPI MISO, USART CLK, Analog Comparator, or Analog In
17	GPIO15/ADC4/TCK/PF4	GPIO_15, JTAG TCK, or Analog In
18	GPIO16/ADC5/TMS/PF5	GPIO_16, JTAG TMS, or Analog In
19	GPIO17/ADC6/TDO/PF6	GPIO_17, JTAG TDO, I2C SDA, or Analog In
20	GPIO18/ADC7/TDI/PF7	GPIO_18, JTAG TDI, I2C SCL, or Analog In
21	VCC	Power Supply
22	GPIO19/OC3A/AIN1/PE3	GPIO_19, PWM, Analog Comparator
23	RESET	Module Reset, Active Low
24	GND	Power Supply

1.3 Electrical Characteristics

Table 1.2. RF200APD1 / RF200APF1 DC Characteristics						
Symbol	Parameter	Condition	Min	Typ ¹	Max	Units
V_{CC}^2	Supply Voltage		2.7	3.3	3.6	V
T_{OP}	Operating Temp		-40		85	°C
V_{IH}	Input Hi Voltage	All Digital Inputs	$V_{CC} - 0.4$			V
V_{IL}	Input Low Voltage	All Digital Inputs			0.4	V
V_{OL}	Output Low Voltage	All drive strengths (2,4,6,8 mA)			0.4	V
V_{OH}	Output High Voltage	All drive strengths (2,4,6,8 mA)	$V_{CC} - 0.4$			V
$I_{L_{IN}}$	In Leakage Current	$V_{IN}=V_{CC}$ or V_{SS} , all Pins			TBD	uA
$TX-I_{CC}$	Transmit Current	$V_{CC} = 3.3V$		80		mA
$RX-I_{CC}$	Receive Current			20		mA
$SHDN-I_{CC}$	Sleep Current	$V_{CC} = 3.3V$	1.4	1.5		uA

¹ All typical specifications are measured at 25 °C.

² Absolute maximum stress rated voltage for VCC is -0.3 to 3.6. It is recommended that a bulk decoupling capacitor (47 uF tantalum rated at 6.3volts) be located close to the VCC pin 21 of the RF200A connector on host board.

Table 1.3. ADC Electrical Characteristics (Operating)						
Symbol	Parameter	Condition	Min	Typical	Max	Unit
V_{REFH}^3	Voltage Reference, High	Programmable	1.5	1.6	1.8	V
V_{INDC}	Analog input voltage	Single Ended	0		1.8	V
		Differential ⁴	0		3.3	

³ V_{REFH} is programmable to three fixed values; 1.5V, 1.6V, and 1.8V. The default is 1.6V.

⁴ Each differential analog input may be as high as 3.3V but the differential voltage is still limited.

Table 1.4. ADC Timing/Performance Characteristics						
Symbol	Parameter	Condition	Min	Typical	Max	Unit
R_{AS}	Source impedance at input ⁵				3k	kΩ
RES	Conversion Resolution	Single Ended CLKADC ≤ 4MHz		10		Bits
		Single Ended CLKADC > 8MHz		8		
DNL	Differential non-linearity	$V_{REFH} = 1.6V$ CLKADC=4MHz	-0.5			LSB
INL	Integral non-linearity	$V_{REFH} = 1.6V$ CLKADC=4MHz		0.8		LSB
E_{ZS}	Zero-scale error			1.5		LSB
E_G	Gain error			1		LSB

⁵ Any analog source with a source impedance greater the 3kΩ will increase the sampling time.

1.4 Mechanical Drawings

These drawings in Figure 1.1 show the module with the RPSMA connector for use with an external antenna, and the keep put area for the F-antenna. There should be no copper, components, or fasteners on any layer of the host board beneath the keep out area.

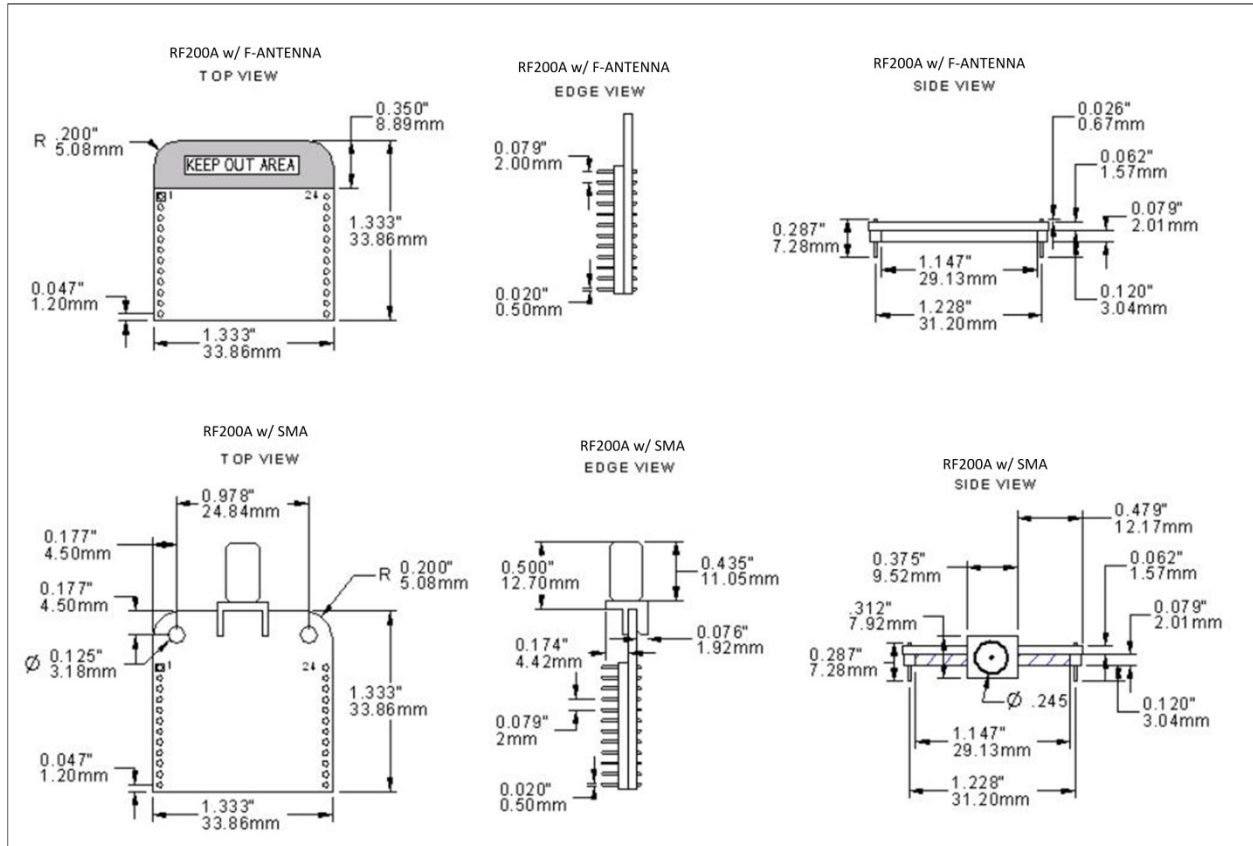

Figure 1.1 Mechanical drawings of the RF200APD1 and RF200APF1 Modules

1.5 Board Mounting Configurations

The RF200PD1 and RF200PF1 modules are designed to mount into a receptacle (socket) on the host board. Picture 1.1 shows an RF200PD1 module plugged in to a host board. The receptacle sockets are on standard 2mm centers. Suggested receptacles to be used on the host are:

Thru-hole receptacle	Samtec	MMS-112-01-L-SV
Surface mount receptacle	Samtec	MMS-112-02-L-SV

It is recommended that the mounting holes provided in the module on either side of the SMA connector be used with supporting mounting hardware to hard mount the module

to either the host board or to the enclosure to handle the mechanical stresses that can occur when an external antenna is screwed into the SMA. Picture 1.1 shows the RF200PD1 with RPSMA connector mounted to the host board.

1.6 Ordering Information

Part Number	Description
RF200APD1	802.15.4 Wireless Module with RPSMA connector
RF200APF1	802.15.4 Wireless Module with PCB Inverted-F Antenna

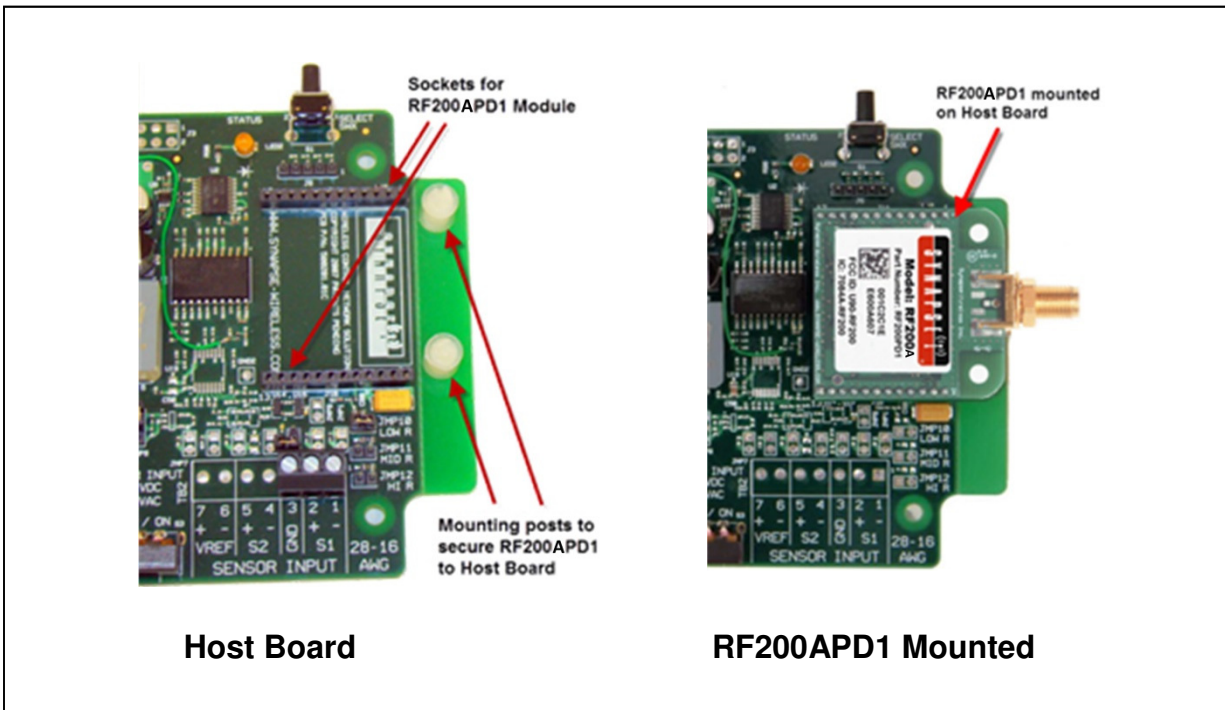

Picture 1.1 RF200APD1 Mounted To Host Board

2.0 Agency Certifications

2.1 United States (FCC)

The Model RF200A modules comply with Part 15 of the FCC rules and regulations. Compliance with the labeling requirements, FCC notices and antenna usage guidelines is required. In order to comply with FCC Certification requirements, the Original Equipment Manufacturer (OEM) must fulfill the following requirements.

1. The system integrator must place an exterior label on the outside of the final product housing the RF200A Modules. Figure 2.1 below shows the contents that must be included in this label.
2. RF200A Modules may only be used with the antenna that has been tested and approved for use with the module. Please refer to the antenna table provided in this section.

2.1.1 OEM Labeling Requirements

NOTICE: The OEM must make sure that FCC labeling requirements are met. This includes a clearly visible exterior label on the outside of the final product housing that displays the contents shown in Figure 2.1 below.

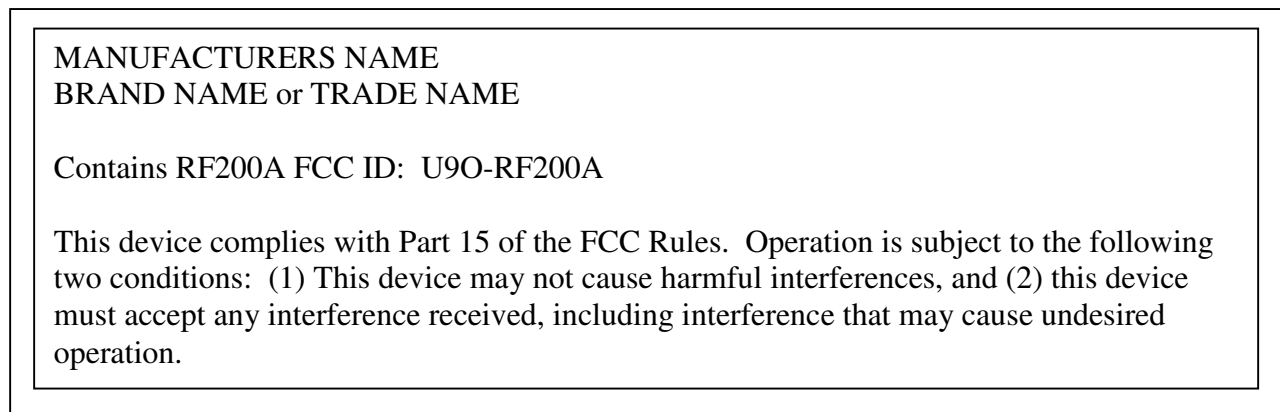

Figure 2.1 FCC Label

2.1.2 FCC Notices

WARNING: The RF200A modules have been tested by the FCC for use with other products without further certification (as per FCC Section 2.1091). Changes or modifications to this device not expressly approved by Synapse Wireless Inc. could void the user’s authority to operate the equipment.

NOTICE: OEM’s must certify final end product to comply with unintentional radiators (FCC Section 15.107 and 15.109) before declaring compliance of their final product to Part 15 of the FCC Rules.

NOTICE: The RF200A modules have been certified for remote and base radio applications. If the module will be used for portable applications, the device must undergo SAR testing.

This equipment has been tested and found to comply with the limits for a Class B digital device, pursuant to Part 15 of the FCC Rules. These limits are designed to provide

reasonable protection against harmful interference in a residential installation. This equipment generates, uses, and can radiate radio frequency energy and, if not installed and used in accordance with the instructions, may cause harmful interference to radio communications. However, there is no guarantee that interference will not occur in a particular installation.

If this equipment does cause harmful interference to radio or television reception, which can be determined by turning the equipment off and on, the user is encouraged to try to correct the interference by one or more of the following measures:

- Reorient or relocate the receiving antenna.
- Increase the separation between the equipment and receiver.
- Connect the equipment into an outlet on a circuit different from that to which the receiver is connected.
- Consult the dealer or an experienced radio/TV technician for help.

2.1.3 FCC Approved Antennas

The RF200A modules are FCC-approved for fixed base station and mobile applications. The FCC requirement for mobile applications states that the antenna must be mounted at least 20 cm (8 in) from nearby persons.

Notice: To reduce potential radio interference to other users, the antenna type and its gain should be chosen so that the equivalent isotropically radiated power (e.i.r.p.) is not more than that permitted for successful communication. The RF200PD1 module has been designed to operate with the antennas listed below in Table 2.1. The required antenna impedance is 50 ohms. The RF200APF1 has a built-in F-antenna.

Table 2.1. Approved FCC Antennas					
Part Number	Type	Gain	Application	Min. Separation	For Use On
Pulse W1027	Dipole (quarter-wave RPSMA)	3.2 dBi	Fixed/Mobile	20 cm	RF200APD1
N/A	Inverted-F	0dBi	Fixed/Mobile	20 cm	RF200PF1

Recommended Antenna (RF200APD1):

Wireless External Antenna for 2.4 GHz Applications

Pulse Part Number: W1027

Features

- High gain antenna
- For WLAN devices using WiFi (802.11b/g), Bluetooth* and ZigBee™
- Omni-directional radiation pattern provides broad 360° coverage
- One-quarter wavelength dipole configuration
- Connection and color options easily integrate with OEM designs

Color Options

- Black*
- Gray (Pantone cool gray 8C)

Connector Options

- Reverse SMA (Male)*
- SMA (Male)

** Default Configuration – Please contact Pulse Applications Engineering for assistance in ordering colors and connectors*

Weight.....13.9 grams
Carton.....20/bag; 500/carton

Dimensions: $\frac{\text{Inches}}{\text{mm}}$
Unless otherwise specified, all tolerances are $\pm \frac{.010}{0.25}$

Electrical Specifications @ 25 °C

Note: This part number is lead-free and RoHS compliant. No additional suffix or identifier is required.

Antenna Part No.	Frequency [GHz]	Gain [dBi]	Impedance [Nom]	VSWR	Polarization	Electrical Length	Radiation	Color
W1027	2.4 – 2.5	3.2	50 Ω	≤ 1.9	Vertical	1/4, dipole	Omni	Black

RF Exposure WARNING: This equipment complies with FCC radiation exposure limits set forth for an uncontrolled environment. This equipment should be installed and operated with minimum distance 20cm between the radiator and your body. This transmitter must not be co-located or operating in conjunction with any other antenna or transmitter.

NOTICE: The preceding statement must be included as a CAUTION statement in OEM product manuals in order to alert users of FCC RF Exposure compliance.

2.2 Canada (IC)

This device complies with Industry Canada license-exempt RSS standard(s). Operation is subject to the following two conditions: (1) this device may not cause interference, and (2) this device must accept any interference, including interference that may cause undesired operation of the device.

Le présent appareil est conforme aux CNR d'Industrie Canada applicables aux appareils radio exempts de licence. L'exploitation est autorisée aux deux conditions suivantes : (1) l'appareil ne doit pas produire de brouillage, et (2) l'utilisateur de l'appareil doit accepter tout brouillage radioélectrique subi, même si le brouillage est susceptible d'en compromettre le fonctionnement.

Under Industry Canada regulations, this radio transmitter may only operate using an antenna of a type and maximum (or lesser) gain approved for the transmitter by Industry Canada. To reduce potential radio interference to other users, the antenna type and its gain should be so chosen that the equivalent isotropically radiated power (e.i.r.p.) is not more than that necessary for successful communication.

Conformément à la réglementation d'Industrie Canada, le présent émetteur radio peut fonctionner avec une antenne d'un type et d'un gain maximal (ou inférieur) approuvé pour l'émetteur par Industrie Canada. Dans le but de réduire les risques de brouillage radioélectrique à l'intention des autres utilisateurs, il faut choisir le type d'antenne et son gain de sorte que la puissance isotrope rayonnée équivalente (p.i.r.e.) ne dépasse pas l'intensité nécessaire à l'établissement d'une communication satisfaisante.

This radio transmitter Model: RF200A, IC: 7084A-RF200A has been approved by Industry Canada to operate with the antenna types listed below with the maximum permissible gain and required antenna impedance for each antenna type indicated. Antenna types not included in this list, having a gain greater than the maximum gain indicated for that type, are strictly prohibited for use with this device.

Le présent émetteur radio Model: RF200, IC: 7084A-RF200A a été approuvé par Industrie Canada pour fonctionner avec les types d'antenne énumérés ci-dessous et ayant un gain admissible maximal et l'impédance requise pour chaque type d'antenne. Les types d'antenne non inclus dans cette liste, ou dont le gain est supérieur au gain maximal indiqué, sont strictement interdits pour l'exploitation de l'émetteur.

Table 2.2. Approved IC Antennas					
Part Number	Type	Gain	Application	Min. Separation	For Use On
Pulse W1027	Dipole (quarter-wave RPSMA)	3.2 dBi	Fixed/Mobile	20 cm	RF200APD1
N/A	Inverted-F	0dBi	Fixed/Mobile	20 cm	RF200PF1

2.2.1 OEM Labeling Requirements

Labeling requirements for Industry Canada are similar to those of the FCC. A clearly visible label on the outside of the final product housing must display the contents shown in Figure 2.2 below.

MANUFACTURERS NAME
BRAND NAME or TRADE NAME
MODEL: RF200A
Contains IC: 7084A-RF200A

Figure 2.2 IC Label

NOTE: The OEM can choose to implement a single label combined for both FCC and IC labeling requirements. If a combined single label is chosen, there must be a clearly visible label on the outside of the final product housing displaying the contents shown in Figure 2.3 below.

MANUFACTURERS NAME
BRAND NAME or TRADE NAME

Contains FCC ID: U9O-RF200A
Contains IC: 7084A-RF200A

This device complies with Part 15 of the FCC Rules. Operation is subject to the following two conditions: (1) This device may not cause harmful interferences, and (2) this device must accept any interference received, including interference that may cause undesired operation.

Figure 2.3 Combined FCC and IC Label