

Appendix

A.4 Application example RFID tag system

Function Symbolic name	Signal	Explanation
Enabling button	ENABLE (F_FB_RNG_4)	"0": No enable "1": Enable
Power ON-OFF robot "E_Stop_Robot"	O11.0	"0": EMERGENCY STOP triggered. "1": Normal operation of plant.
Actuator to robot	O11.1	"0": The robot is not operated with Key1 and the enabling buttons "1": The robot is operated with Key1 and the enabling buttons
Signal lamp	O 11.2	"0": Robot is not in use; the signal lamp is off "1": Robot is in use; the signal lamp is on

Flowchart

The following flowchart shows the operation sequence in the example.

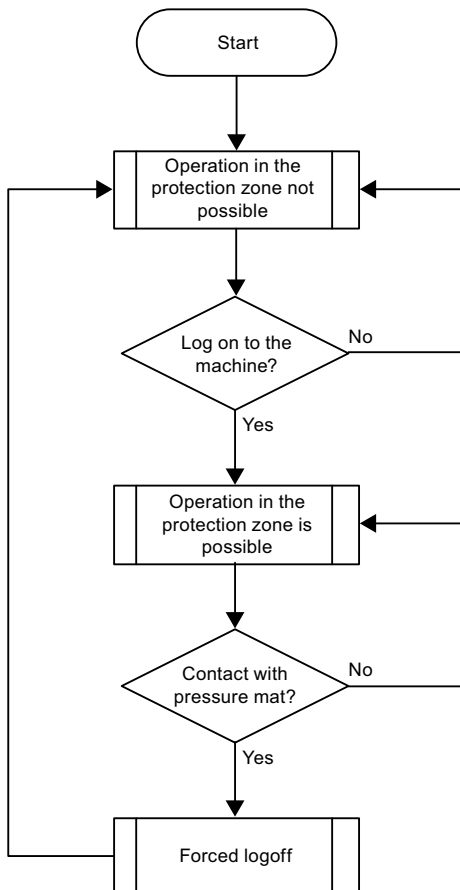

A.4.2 Configuring the controller and HMI device in STEP 7

This section describes the most important parameters you need to set in "HW Config" for the F-CPU and for the HMI device.

<p>⚠ WARNING</p> <p>Safety category</p> <p>Any changes to parameters may result in the loss of the safety category.</p> <p>Set the parameters as described. The parameters will contribute to meeting safety category 4 PL e/SIL 3.</p>

Requirement

The software for fail-safe operation has been installed, see section "Required software (Page 25)".

Procedure – Configuring CPU 317F-2 PN/DP

Proceed as follows:

1. Create a STEP 7 project in SIMATIC Manager.
2. Open the "HW Config" hardware configuration and insert the desired F-CPU and a PROFINET connection, as shown in the following figure:

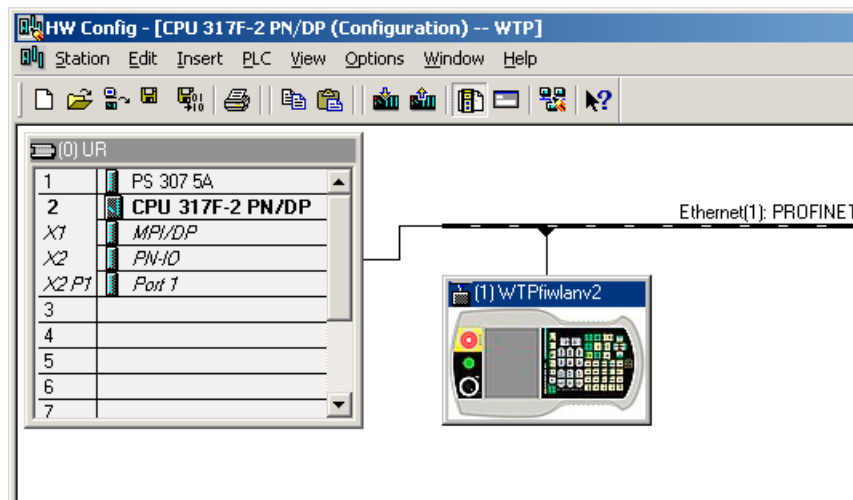



3. Open the settings by double-clicking the F-CPU in "HW Config".

Appendix

A.4 Application example RFID tag system

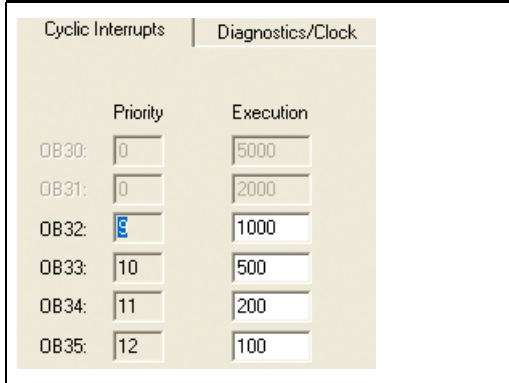
The table below shows the most important settings:

Setting	Explanation																					
 <table border="1"> <thead> <tr> <th></th> <th>Priority</th> <th>Execution</th> </tr> </thead> <tbody> <tr> <td>OB30:</td> <td>0</td> <td>5000</td> </tr> <tr> <td>OB31:</td> <td>0</td> <td>2000</td> </tr> <tr> <td>OB32:</td> <td>8</td> <td>1000</td> </tr> <tr> <td>OB33:</td> <td>10</td> <td>500</td> </tr> <tr> <td>OB34:</td> <td>11</td> <td>200</td> </tr> <tr> <td>OB35:</td> <td>12</td> <td>100</td> </tr> </tbody> </table>		Priority	Execution	OB30:	0	5000	OB31:	0	2000	OB32:	8	1000	OB33:	10	500	OB34:	11	200	OB35:	12	100	<p>This is where you set the cycle time for OB35.</p> <p>Note If the cycle time for OB35 is set lower than the PBIO update time, the message frame may be lost and the evaluation of the "E-STOP" output of F_FB_RNG_4 or F_FB_RNG_16 may be delayed.</p> <p>Set the cycle time of OB35 to a value higher than the PNIO update time.</p>
	Priority	Execution																				
OB30:	0	5000																				
OB31:	0	2000																				
OB32:	8	1000																				
OB33:	10	500																				
OB34:	11	200																				
OB35:	12	100																				
 <p>Protection level</p> <p><input checked="" type="radio"/> 1: Access protect. for F CPU <input checked="" type="checkbox"/> Can be bypassed with password</p> <p><input type="radio"/> 2: Write-protection</p> <p><input type="radio"/> 3: Write-/read protection</p> <p>Password: <input type="text"/></p> <p>Enter again: <input type="text"/></p> <p><input checked="" type="checkbox"/> CPU contains safety program</p>	<p>Assign a password for the safety program.</p> <p>Set the "CPU contains safety program" check box.</p> <p>This setting is required to generate all the necessary F-FBs for safe operation of the fail-safe modules during compilation of "HW Config" by STEP 7.</p>																					

Procedure – Configuring Wireless Teach Pendant F IWLAN

Proceed as follows:

1. Insert the Wireless Teach Pendant F IWLAN in "HW Config" as shown in the following figure.

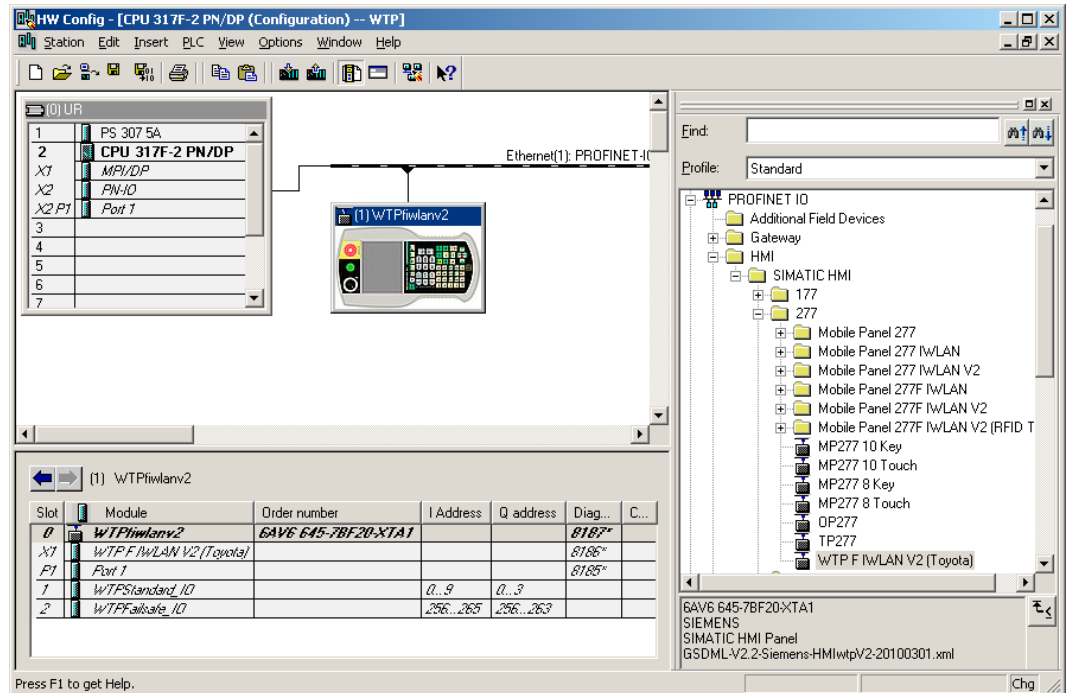

2. Open the properties dialog of the HMI device by double-clicking the "WTPfiwlan" icon.
3. Enter the device name of the HMI device in the properties dialog.
4. Open the properties dialog of the "WTPFailsafe_IO" module by double-clicking the "WTPFailsafe_IO" entry in the detailed view of the HMI device.
5. Change to the "PROFIsafe" tab.

The table below shows the most important settings:

Setting	Explanation																					
<p>General IO Cycle</p> <p>Short description: mobile277fiwlan</p> <p>SIMATIC HMI Panel</p> <p>Order no.: 6AV6 645-0DB01-0AX0</p> <p>Family: SIMATIC HMI</p> <p>Device name: WTPfiwlan</p> <p>GSD file: GSDML-V2.1-Siemens-HMI-20070921.xml</p> <p>Change Release Number...</p>	<p>Device name</p> <p>Here you assign a device name to the HMI device, which is unique in the local Ethernet network segment. This name must match the name defined in the Control Panel of the HMI device under "PROFINET" in the text box "Device name:".</p> <p>Additional information is available in the section: "Specifying the computer name of the HMI device (Page 174)".</p>																					
<p>General Addresses PROFIsafe</p> <p>Inputs</p> <p>Start: 256 Process image: DB1 PI</p> <p>End: 265</p> <p>Outputs</p> <p>Start: 256 Process image: DB1 PI</p> <p>End: 263</p>	<p>Inputs</p> <p>This is where you specify the start address of the inputs and the process image associated with this address area (PII).</p> <p>Outputs</p> <p>Here you specify the start address of the outputs and the process image associated with this address area (PIQ).</p>																					
<p>General Addresses PROFIsafe</p> <table border="1"> <thead> <tr> <th>Parameter name</th> <th>Value</th> <th>Hex</th> </tr> </thead> <tbody> <tr> <td>F_SIL</td> <td>SIL3</td> <td></td> </tr> <tr> <td>F_Block_ID</td> <td>0</td> <td></td> </tr> <tr> <td>F_Par_Version</td> <td>1</td> <td></td> </tr> <tr> <td>F_Source_Add</td> <td>2000</td> <td></td> </tr> <tr> <td>F_Dest_Add</td> <td>200</td> <td>C8</td> </tr> <tr> <td>F_WD_Time</td> <td>500</td> <td></td> </tr> </tbody> </table>	Parameter name	Value	Hex	F_SIL	SIL3		F_Block_ID	0		F_Par_Version	1		F_Source_Add	2000		F_Dest_Add	200	C8	F_WD_Time	500		<p>F_Dest_Add</p> <p>PROFIsafe address of the Wireless Teach Pendant F IWLAN. This address must match the address on the HMI device.</p> <p>F_WD_Time</p> <p>Monitoring time in the fail-safe IO device.</p> <p>A valid current safety message frame must reach the F-CPU and be returned to the HMI device within the monitoring time period. This ensures that failures and errors are detected and appropriate responses are triggered to keep the fail-safe system in a safe state or transfer it to a safe state.</p> <p>The monitoring time selected must be long enough that message frame delays will be tolerated by the communication system, but also that the fault reaction function responds quickly enough in the event of a fault (e.g. interruption in the communication connection).</p>
Parameter name	Value	Hex																				
F_SIL	SIL3																					
F_Block_ID	0																					
F_Par_Version	1																					
F_Source_Add	2000																					
F_Dest_Add	200	C8																				
F_WD_Time	500																					

A.4.3 Safety program S7 Distributed Safety

In the safety program of the S7-CPU, the operation sequence of the application example is implemented by the following programming:

- Once the HMI device is logged on to a machine, the signal lamp and the "Override" mode are enabled.
- In the protection zone, the operator can operate the robot with the "Key1" button and the enabling button.
- If the operator leaves the protection zone over the contact pressure mat, the safety program responds as follows:
 - The signal lamp goes out.
 - "Override" mode is deactivated.
 - The HMI device is logged off the machine.
- After an EMERGENCY STOP, the plant only restarts when the operator performs an acknowledgment.
- Reactions specific to a plant are initiated when a rampdown or shutdown occurs.

Safety program

The safety program is structured as follows:

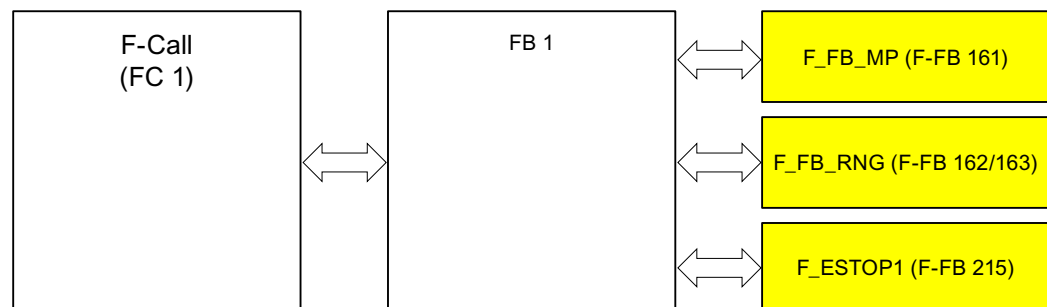

Symbolic names

The following symbolic names are used in the networks of the sample programs

Symbolic name	Meaning
F00256_WTPFail-safe_IO	Fail-safe I/O DB of HMI device
MP1_FB_S7_MP_RE	Input which is set when a reset of the HMI device is performed from the F-CPU.
MP1_FB_S7_ACK_ERR	Input which is set when a communication error is acknowledged from the F-CPU.
MP1_F_DATA_PII	Word 1 of the PII of the HMI device
MP1_F_RANGE_PII	Word 2 of the PII of the HMI device
MP1_F_DATA_PIQ	Word 1 of the PIQ of the HMI device
MP1_F_RANGE_PIQ	Word 2 of the PIQ of the HMI device

Appendix

A.4 Application example RFID tag system

Symbolic name	Meaning
Interface_DB	F-DB for the data transfer of user data
F_DB_States	F-DB for the transfer of data between the F_FB_MP of the HMI device and the F_FB_RNG_n of the effective range

F-CALL (FC 1)

F-CALL (FC1) is the F-run-time group and is called from the cyclic interrupt OB (OB35).
F-CALL (FC1) calls the F-program block (in this case: FB1).

FB1

For reasons of program modularity, all other F-FBs are called from this FB.
In FB 1, you have to call the F-FBs in the following order.

1. Network 1

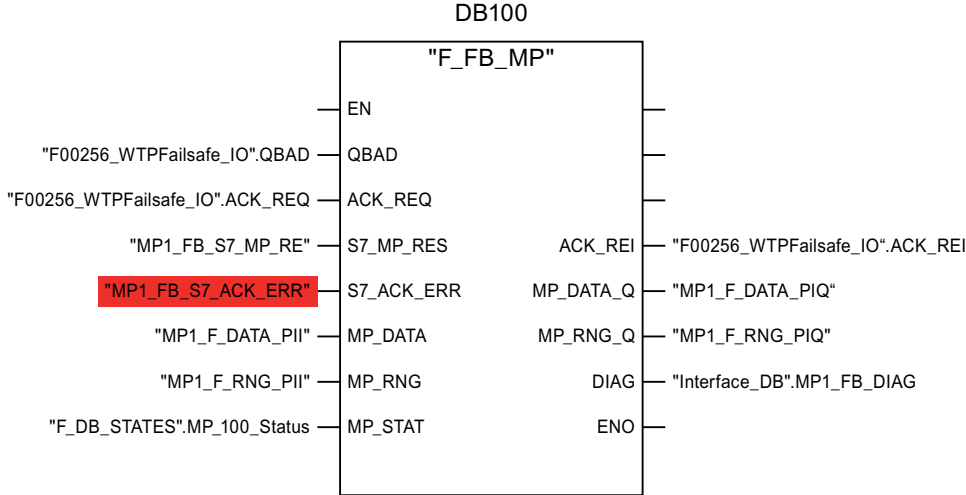

The controller uses this F-FB to monitor the PROFIsafe communication of the HMI device. The following diagnostics information is indicated at the "DIAG" output:

- Status of the HMI device: integrated or removed
- A communication error has occurred.
- Communication error must be acknowledged

2. Network 2

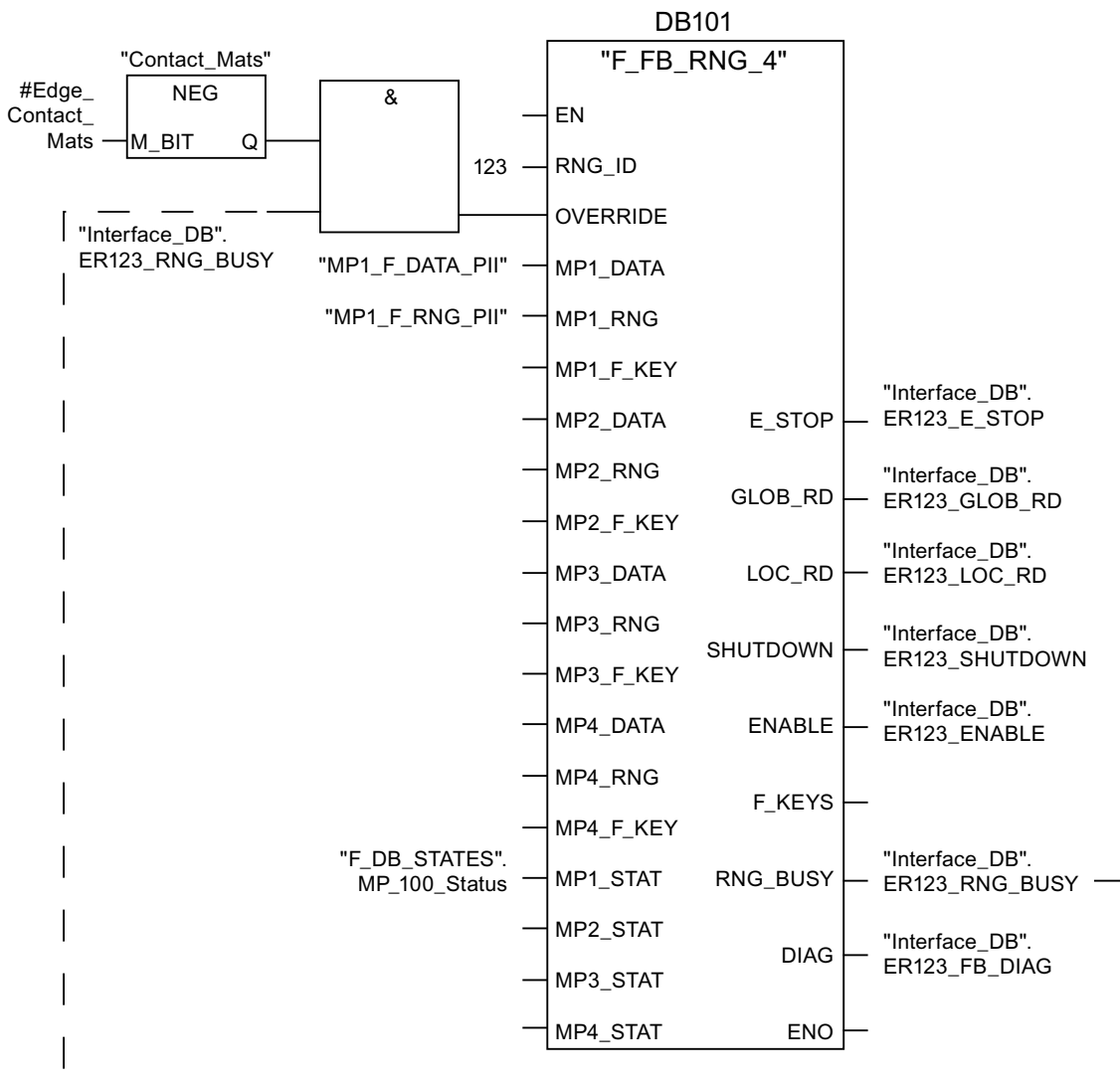

The activation of the "override" mode is controlled in this network.

"OVERRIDE" is set as soon as the operator has logged the HMI device on to the machine via the RFID tag. (RNG_BUSY). "OVERRIDE" is reset by a negative edge on the contact pressure mat, in other words I11.0 = "0". This is the case when the operator leaves the protection zone.

At the same time, F_FB_RNG monitors the signals "EMERGENCY STOP", "Global rampdown", "Local rampdown" and "Shutdown". They are scanned in networks 3 to 6.

3. Network 3

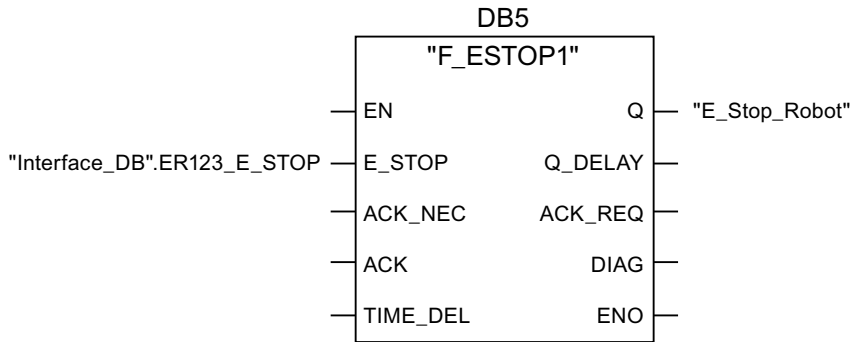

In network 3, the EMERGENCY STOP signal of the HMI device is monitored via F_ESTOP1 from the F-library of S7 Distributed Safety. F_ESTOP1 ensures that the plant is only able to restart following an EMERGENCY STOP after acknowledgment by the operator via the input "ACK".

Note

Read also the information on FB215 in the online help for F-FBs and in the manual "SIMATIC S7-Distributed Safety, Configuring and Programming", section "FB215 "F_ESTOP1:" Emergency STOP up to Stop Category 1".

4. Networks 4, 5 and 6

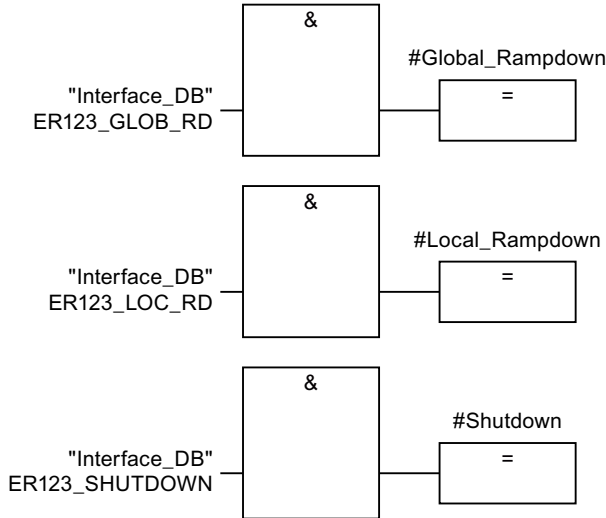

In network 4, 5 and 6 the signals for a global and a local rampdown and shutdown are processed further. As the configuration of the monitored plant determines which responses have to occur following occurrence of a particular safety state, these networks are not explained in detail in this example.

5. Network 7

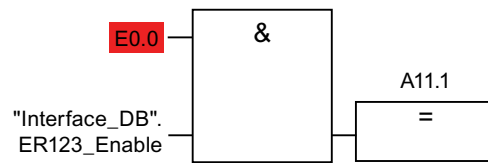

If the operator simultaneously presses the Key1 key and the enabling button, the robot is activated via the output Q11.1.

6. Network 8

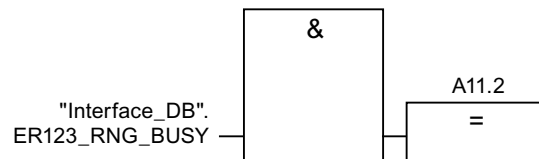

If the "RNG_BUSY" signal is set in F_FB_RNG, output Q11.2 is used to control the signal lamp that indicates whether or not the machine is in use.

A.5 Safety-related messages

A.5.1 Transponder system

The following safety-related messages are displayed in fail-safe mode depending on the operating situation. In contrast to system alarms, no message window needs to be configured for safety-related messages.

NOTICE





Function keys inactive for the display length of the alarm



While a safety-related alarm is shown, the function keys of the HMI device are inactive.

Close the window of the safety-related alarm in order to reactivate the function keys.

Appendix

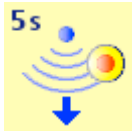

A.5 Safety-related messages

Dialog	Reaction	Situation
<p>Establishment of safety connection</p>  <p>No safe connection available. Reason:</p> <ul style="list-style-type: none"> • Connection not yet completed • PROFIsafe address error • Internal configuration error • Communication error (timeout) • Communication error (CRC) • CPU in STOP • PROFIsafe CRC configuration error <p>Should the Panel be switched off?</p>	<p>"Yes" button</p>	<p>The following is reported in the warning message depending on the operating situation:</p> <ul style="list-style-type: none"> • Connection not yet completed The safe connection is not yet established after the project has been started. Wait until the connection has been established. The dialog is closed on completion. • A communication error occurred after the HMI device was successfully integrated. Correct the cause of the error described by "Reason".
<p>Start removal</p>  <p>The removal cannot be interrupted once it has started. Do you want to start the removal?</p>	<p>"Yes" button "No" button</p>	<p>The "Start removal" dialog opens in the following cases:</p> <ul style="list-style-type: none"> • The operator has pressed the "ON/OFF" button for more than 4 seconds. • The operator has pressed the operator control for closing the project.
<p>Confirm removal</p>  <p>Please confirm the removal with the enabling button.</p>	<p>Press an enabling button until the "Enable" switch position is reached.</p>	<p>The removal starts, in other word, the user has pressed the "Yes" button in the "Start removal" dialog.</p>
<p>Effective range logon</p>  <p>Do you want to logon to the following effective range? Effective range <<EFFECTIVE RANGE NAME>> Please enter the effective range ID:</p>	<p>"Yes" button "No" button</p>	<p>The HMI device is located within an effective range but it is not logged on. The operator has activated the white "Effective range name" object to log on.</p>

Dialog	Reaction	Situation
<p>Effective range logoff</p>  <p>Do you want to log off from the following effective range? Effective range <<EFFECTIVE RANGE NAME>></p>	<p>"Yes" button "No" button</p>	<p>The HMI device is logged onto the effective range. The operator has activated the "Effective range name" object to log off.</p>
<p>Effective range logoff (shutdown)</p>  <p>The Panel cannot be switched off. You first have to log off from the effective range. Do you want to logoff from the following effective range? Effective range <<EFFECTIVE RANGE NAME>></p>	<p>"Yes" button "No" button</p>	<p>The HMI device is logged on to a machine. The operator has attempted to:</p> <ul style="list-style-type: none"> • Shut down the HMI device. • Close the project with the corresponding operator control.
<p>Acknowledgment of communication error</p>  <p>A safe connection is possible again. Please confirm the communication error.</p>	<p>"OK" button</p>	<p>Communication was recovered after a short communication error. The operator must confirm this state. Causes:</p> <ul style="list-style-type: none"> • The operator has briefly left the WLAN range and then returned. • PROFI-safe communication was briefly interrupted.
<p>Effective range exited without logoff(5 seconds)</p>  <p>WARNING: You have exited the following effective range without logging off: Effective range <<EFFECTIVE RANGE NAME>> The enabling button is deactivated. Do you want to log off from the effective range?</p>	<p>"Yes" button or Return to the effective range within 25 seconds</p>	<p>The operator has left the effective range with the logged on HMI device for more than 5 seconds.</p>

Appendix

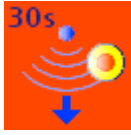
A.5 Safety-related messages

Dialog	Reaction	Situation
<p>Effective range exited without logoff(30 seconds)</p>  <p>You have left the effective range without permission. A local shutdown was initiated! Please confirm logging off from the effective range.</p>	"OK" button	The operator has left the effective range with the logged on HMI device for more than 30 seconds.
<p>Low battery alarm</p> <p>Battery charge is less than 20 percent.</p>	"OK" button	The remaining charge of the main rechargeable battery is less than 20%. An additional system alarm is output after the charge of the main rechargeable battery has dropped to less than 6%.
<p>Testing transponders</p> <p>This dialog contains no coherent text.</p> <p>Users are informed that they are in a mode for testing the transponders. The user muss test all transponders in all effective ranges.</p>	Diverse	A project has been started on the HMI device that does not contain an up-to-date CRC checksum for the effective ranges. The effective ranges and transponders need to be tested using the dialog.
<p>Test enabling button</p>  <p>Both enabling buttons must be tested to ensure they are operational. Fully press both enabling buttons until the panic position is reached.</p>	Press both enabling buttons until the "Panic" switch position is reached.	The operator has started the project. Perform a function test for the enabling button.

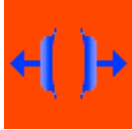
Dialog	Reaction	Situation
<p>Error during effective range logon</p>  <p>Error during effective range logon. The enabling button remains deactivated.</p>	<p>"OK" button</p>	<p>An error occurred during logon of the HMI device to a machine. The operator cannot use the enable switches to control the production process.</p> <p>Possible causes:</p> <ul style="list-style-type: none"> • You are already logged on to the machine with your HMI device or the logon is currently in progress. • Another HMI device is already logged on to the machine. • Transponder defective. • Effective range module in the HMI device is defective. • No ID has been assigned to the transponder. • The operator has entered an incorrect effective range ID for the logon. • F_FB_RNG missing in the STEP7 configuration. • F_FB_RNG is wired incorrectly in STEP7.
<p>Enabling switch discrepancy error</p>  <p>Please release the enabling button.</p>	<p>Release both enabling buttons.</p>	<p>The HMI device detects a discrepancy at one of the two enabling buttons in switch position "Enable".</p>





A.5.2 RFID tag system



The following safety-related messages are displayed in fail-safe mode depending on the operating situation. In contrast to system alarms, no message window needs to be configured for safety-related messages.

NOTICE
<p>Function keys inactive for the display length of the alarm</p> <p>While a safety-related alarm is shown, the function keys of the HMI device are inactive. Close the window of the safety-related alarm in order to reactivate the function keys.</p>

Appendix

A.5 Safety-related messages

Dialog	Reaction	Situation
<p>Establishment of safety connection</p>  <p>No safe connection available. Reason:</p> <ul style="list-style-type: none"> • Connection not yet completed • PROFIsafe address error • Internal configuration error • Communication error (timeout) • Communication error (CRC) • CPU in STOP • PROFIsafe CRC configuration error <p>Should the Panel be switched off?</p>	<p>"Yes" button</p>	<p>The following is reported in the warning message depending on the operating situation:</p> <ul style="list-style-type: none"> • Connection not yet completed The safe connection is not yet established after the project has been started. Wait until the connection has been established. The dialog is closed on completion. • A communication error occurred after the HMI device was successfully integrated. Correct the cause of the error described by "Reason".
<p>Start removal</p>  <p>The removal cannot be interrupted once it has started. Do you want to start the removal?</p>	<p>"Yes" button "No" button</p>	<p>The "Start removal" dialog opens in the following cases:</p> <ul style="list-style-type: none"> • The operator has pressed the "ON/OFF" button for more than 4 seconds. • The operator has pressed the operator control for closing the project.
<p>Confirm removal</p>  <p>Please confirm the removal with the enabling button.</p>	<p>Press an enabling button until the "Enable" switch position is reached.</p>	<p>The removal starts, in other word, the user has pressed the "Yes" button in the "Start removal" dialog.</p>
<p>Effective range logon</p>  <p>Do you want to logon to the following effective range? Effective range <<EFFECTIVE RANGE NAME>> Please enter the effective range ID:</p>	<p>"Yes" button "No" button</p>	<p>The HMI device is located directly in front of an RFID tag and is not yet logged on to the corresponding machine. The operator has activated the "Scan" object to log on.</p> <div style="border: 1px solid black; padding: 2px; width: fit-content; margin: 10px auto;">Scan</div>

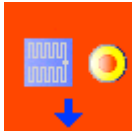
Dialog	Reaction	Situation
<p>Effective range logoff</p>  <p>Do you want to log off from the following effective range? Effective range <<EFFECTIVE RANGE NAME>></p>	<p>"Yes" button "No" button</p>	<p>The HMI device is logged on to a machine. The operator has activated the "Effective range name (RFID)" object to log off.</p>
<p>Effective range logoff (shutdown)</p>  <p>The Panel cannot be switched off. You first have to log off from the effective range. Do you want to logoff from the following effective range? Effective range <<EFFECTIVE RANGE NAME>></p>	<p>"Yes" button "No" button</p>	<p>The HMI device is logged on to a machine. The operator has attempted to:</p> <ul style="list-style-type: none"> • Shut down the HMI device. • Close the project with the corresponding operator control.
<p>Acknowledgment of communication error</p>  <p>A safe connection is possible again. Please confirm the communication error.</p>	<p>"OK" button</p>	<p>Communication was recovered after a short communication error. The operator must confirm this state. Causes:</p> <ul style="list-style-type: none"> • The operator has briefly left the WLAN range and then returned. • PROFI-safe communication was briefly interrupted.
<p>Forced logoff</p>  <p>You are automatically logged off from the effective range. A local rampdown has been triggered! Confirm the logoff from the effective range.</p>	<p>"OK" button</p>	<p>The operator has left the protection zone with a logged-on HMI device via the safety system.</p>
<p>Low battery alarm</p> <p>Battery charge is less than 20 percent.</p>	<p>"OK" button</p>	<p>The remaining charge of the main rechargeable battery is less than 20%. An additional system alarm is output after the charge of the main rechargeable battery has dropped to less than 6%.</p>

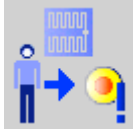
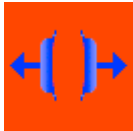
Dialog	Reaction	Situation
<p>Test enabling button</p>  <p>Both enabling buttons must be tested to ensure they are operational. Fully press both enabling buttons until the panic position is reached.</p>	<p>Press both enabling buttons until the "Panic" switch position is reached.</p>	<p>The operator has started the project. Perform a function test for the enabling button.</p>
<p>Error during effective range logon</p>  <p>Error during effective range logon. The enabling button remains deactivated.</p>	<p>"OK" button</p>	<p>An error occurred during logon of the HMI device to a machine. The operator cannot use the enable switches to control the production process.</p> <p>Possible causes:</p> <ul style="list-style-type: none"> • You are already logged on to the machine with your HMI device or the logon is currently in progress. • Another HMI device is already logged on to the machine. • RFID tag is defective. • RFID module in the HMI device is defective. • No ID has been assigned to the RFID tag. • The operator has entered an incorrect RFID tag ID for the logon. • F_FB_RNG missing in the STEP7 configuration. • F_FB_RNG is wired incorrectly in STEP7.
<p>Enabling switch discrepancy error</p>  <p>Please release the enabling button.</p>	<p>Release both enabling buttons.</p>	<p>The HMI device detects a discrepancy at one of the two enabling buttons in switch position "Enable".</p>

A.6 System alarms

Introduction

System alarms on the HMI device provide information about internal states of the HMI device and PLC.

The following overview shows the causes of system alarms and how to eliminate the cause of error.

Some of the system alarms described in this section are relevant to individual HMI devices based on their range of features.

Note

System alarms are only indicated if an alarm window was configured. System alarms are output in the language currently set on your HMI device.

System alarm parameters

System alarms may contain encrypted parameters which are relevant to troubleshooting because they provide a reference to the source code of the runtime software. These parameters are output after the text "Error code:"

Displaying the "System alarms" editor

You can find the text content of the system alarm in WinCC flexible. The "System alarms" editor is not displayed by default in WinCC flexible.

1. Enable the "System alarms" editor under "Options > Setting... > Workbench > Settings for Project Window" with "Display all entries".
2. Select the "System alarms" editor under "Alarms" in the project view.

The system alarms are sorted numerically in the "System alarms" editor.

Configuring events for system alarms

You can configure the "Incoming" event for the following system alarm in the "System alarms" editor.

System alarms		
10000	150000	230300
• 10000 to 10006	• 150000 • 150001	• 230300 to 230308
20000	160000	240000
• 20000 to 20015	• 160000 • 160001 • 160010 to 160014	• 240000 to 240005
30000	170000	250000
• 30010 to 20012	• 170000 to 170004 • 170007	• 250000 to 250003

Appendix

A.6 System alarms

System alarms		
40000	180000	260000
• 40010	• 180000 to 180002	• 260000 to 260009
• 40011		• 260012 to 260014
		• 260028
		• 260030
		• 260033 to 260045
50000	190000	270000
• 50000	• 190000 to 190002	• 270000 to 270003
• 50001	• 190004 to 190013	
60000	190100	280000
• 60010 to 60011	• 190100 to 190102	• 280000 to 280004
70000	200000	290000
• 70010 to 70044	• 200000 to 200005	• 290000 to 290008
		• 290010 to 290014
		• 290020 to 290027
		• 290040 to 290042
		• 290044
		• 290050 to 290065
		• 290070 to 290073
		• 290075
80000	200100	300000
• 80001 to 80035	• 200100 to 200105	• 300000
• 80044 to 80050		• 300001
90000	210000	310000
• 90024 to 90026	• 210000 to 210006	• 310000
• 90029 to 90033		• 310001
• 90040		
• 90041		
• 90044		
110000	220000	600000
• 110000 to 110006	• 220000 to 220008	• 600000
120000	230000	620000
• 120000 to 120002	• 230000	• 620000
	• 230002	
	• 200003	
	• 200005	
130000	230100	
• 130000 to 130012	• 230100	
140000	230200	
• 140000 to 140020	• 230200 to 230203	

10000 - Printer alarms

Number	Effect/cause	Remedy
10000	The print job could not be started or was canceled due to an unknown error. Faulty printer setup. Or: No authorization is available for accessing the network printer. Power supply failure during data transfer.	Check the printer settings, cable connections and the power supply. Set up the printer once again. Obtain a network printer authorization. If the error persists, contact the Hotline!
10001	No printer is installed or a default printer has not been set up.	Install a printer and/or select it as the default printer.
10002	Overflow of the graphics buffer for printing. Up to two graphics are buffered.	Allow sufficient intervals between successive print jobs.
10003	Graphics can now be buffered again.	--
10004	Overflow of the buffer for printing lines in text mode (e.g. alarms). Up to 1000 lines are buffered.	Allow sufficient intervals between successive print jobs.
10005	Text lines can now be buffered again.	--
10006	The Windows printing system reports an error. Refer to the output text and the error ID to determine the possible causes. Nothing is printed or the print is faulty.	Repeat the action if necessary.

20000 - Global script alarms

Number	Effect/causes	Remedy
20010	An error has occurred in the specified script line. Execution of the script was therefore aborted. Note the system alarm that may have occurred prior to this.	Select the specified script line in the configuration. Ensure that the tags used are of the allowed types. Check system functions for the correct number and types of parameters.
20011	An error has occurred in a script that was called by the specified script. Execution of the script was therefore aborted in the called script. Note the system alarm that may have occurred prior to this.	In the configuration, select the script that has been called directly or indirectly by the specified script. Ensure that the tags used are of the allowed types. Check system functions for the correct number and types of parameters.
20012	The configuration data is inconsistent. The script could therefore not be generated.	Recompile the configuration.
20013	The scripting component of WinCC flexible Runtime is not correctly installed. Therefore, no scripts can be executed.	Reinstall WinCC flexible Runtime on your PC. Rebuild your project with "Project > Compiler > Generate" and transfer the project to the HMI device.
20014	The system function returns a value that is not written in any return tag.	Select the specified script in the configuration. Check whether the script name has been assigned a value.
20015	Too many successive scripts have been triggered in short intervals. When more than 20 scripts are queued for processing, any subsequent scripts are rejected. In this case, the script indicated in the alarm is not executed.	Find what is triggering the scripts. Extend the times, e.g. the polling time of the tags which trigger the scripts.

Appendix

A.6 System alarms

30000 - Alarms for IFwSetValue: SetValue()

Number	Effect/causes	Remedy
30010	The tag could not accept the function result, e.g. when it has exceeded the value range.	Check the tag type of the system function parameter.
30011	A system function could not be executed because the function was assigned an invalid value or type in the parameter.	Check the parameter value and tag type of the invalid parameter. If a tag is used as a parameter, check its value.
30012	A system function could not be executed because the function was assigned an invalid value or type in the parameter.	Check the parameter value and tag type of the invalid parameter. If a tag is used as a parameter, check its value.

40000 - Linear scaling alarms

Number	Effect/causes	Remedy
40010	The system function could not be executed since the parameters could not be converted to a common tag type.	Check the parameter types in the configuration.
40011	The system function could not be executed since the parameters could not be converted to a common tag type.	Check the parameter types in the configuration.

50000 - Data server alarms

Number	Effect/causes	Remedy
50000	The HMI device is receiving data faster than it is capable of processing. Therefore, no further data is accepted until all current data have been processed. Data exchange then resumes.	--
50001	Data exchange has been resumed.	--

60000 - Win32 function alarms

Number	Effect/causes	Remedy
60000	This alarm is generated by the "DisplaySystemAlarms" function. The text to be displayed is transferred to the function as a parameter.	--
60010	The file could not be copied in the direction defined because one of the two files is currently open or the source/target path is not available. It is possible that the Windows user has no access rights to one of the two files.	Restart the system function or check the paths of the source/target files. Using Windows NT/XP: The user running WinCC flexible Runtime must be granted access rights to the files.
60011	An attempt was made to copy a file to itself. It is possible that the Windows user has no access rights to one of the two files.	Check the path of the source/target file. Using Windows NT/XP with NTFS: The user running WinCC flexible Runtime must be granted access rights to the files.

70000 - Win32 function alarms

Number	Effect/causes	Remedy
70010	The application could not be started because it could not be found in the path specified or there is insufficient memory space.	Check whether the application exists in the specified path or close other applications.
70011	The system time could not be modified. The error alarm only appears in connection with area pointer "Date/time PLC". Possible causes: <ul style="list-style-type: none"> An invalid time was transferred in the job mailbox. The Windows user has no right to modify the system time. If the first parameter in the system alarm is displayed with the value 13, the second parameter indicates the byte containing the incorrect value.	Check the time which is to be set. Using Windows NT/XP: Users running WinCC flexible Runtime must be granted the right to modify the system time of the operating system.
70012	An error occurred when executing the function "StopRuntime" with the option "Runtime and operating system". Windows and WinCC flexible Runtime are not closed. One possible cause is that other programs cannot be closed.	Close all programs currently running. Then close Windows.
70013	The system time could not be modified because an invalid value was entered. Incorrect separators may have been used.	Check the time which is to be set.
70014	The system time could not be modified. Possible causes: <ul style="list-style-type: none"> An invalid time was transferred. The Windows user has no right to modify the system time. Windows rejects the setting request.	Check the time which is to be set. Using Windows NT/XP: Users running WinCC flexible Runtime must be granted the right to modify the system time of the operating system.
70015	The system time could not be read because Windows rejects the reading function.	--
70016	An attempt was made to select a screen by means of a system function or job. This is not possible because the screen number specified does not exist. Or: A screen could not be generated due to insufficient system memory. Or: The screen is blocked. Or: Screen call has not been executed correctly.	Check the screen number in the function or job with the screen numbers configured. Assign the number to a screen if necessary. Check the details for the screen call and whether the screen is blocked for specific users.
70017	Date/time is not read from the area pointer because the address set in the PLC is either not available or has not been set up.	Change the address or set up the address in the PLC.
70018	Acknowledgment that the password list has been successfully imported.	--
70019	Acknowledgment that the password list has been successfully exported.	--
70020	Acknowledgment for activation of alarm reporting.	--

Appendix

A.6 System alarms

Number	Effect/causes	Remedy
70021	Acknowledgment for deactivation of alarm reporting.	--
70022	Acknowledgment to starting the Import Password List action.	--
70023	Acknowledgment to starting the Export Password List action.	--
70024	The range of values of the tag was exceeded in the system function. No calculation of the system function.	Check and correct the calculation.
70025	The range of values of the tag was exceeded in the system function. No calculation of the system function.	Check and correct the calculation.
70026	No other screens are stored in the internal screen memory. No other screens can be selected.	--
70027	The backup of the RAM file system has been started.	--
70028	The files from the RAM have been copied in the Flash memory. The files from the RAM have been copied in the Flash memory. Following a restart, these saved files are copied back to the RAM file system.	--
70029	Backup of the RAM file system has failed. No backup copy of the RAM file system has been made.	Check the settings in the "Control Panel > OP" dialog and save the RAM file system using the "Save Files" button in the "Persistent Storage" tab.
70030	The parameters configured for the system function are faulty. The connection to the new PLC was not established.	Compare the parameters configured for the system function with the parameters configured for the PLCs and correct them as necessary.
70031	The PLC configured in the system function is not an S7 PLC. The connection to the new PLC was not established.	Compare the S7 PLC name parameter configured for the system function with the parameters configured for the PLC and correct them as necessary.
70032	The object configured with this number in the tab order is not available in the selected screen. The screen changes but the focus is set to the first object.	Check the number of the tab order and correct it if necessary.
70033	An e-mail cannot be sent because a TCP/IP connection to the SMTP server no longer exists. This system alarm is generated only at the first attempt. All subsequent unsuccessful attempts to send an e-mail will no longer generate a system alarm. The event is regenerated when an e-mail has been successfully sent in the meantime. The central e-mail component in WinCC flexible Runtime attempts, in regular intervals (1 minute), to establish the connection to the SMTP server and to send the remaining e-mails.	Check the network connection to the SMTP server and re-establish it if necessary.
70034	Following a disruption, the TCP/IP connection to the SMTP server could be re-established. The queued e-mails are then sent.	--

Number	Effect/causes	Remedy
70036	No SMTP server for sending e-mails is configured. An attempt to connect to an SMTP server has failed and it is not possible to send e-mails. WinCC flexible Runtime generates the system alarm after the first attempt to send an e-mail.	Configure an SMTP server: In WinCC flexible Engineering System using "Device settings > Device settings" In the Windows CE operating system using "Control Panel > Internet Settings > E-mail > SMTP Server"
70037	An e-mail cannot be sent for unknown reasons. The contents of the e-mail are lost.	Check the e-mail parameters (recipient etc.).
70038	The SMTP server has rejected sending or forwarding an e-mail because the domain of the recipient is unknown to the server or because the SMTP server requires authentication. The contents of the e-mail are lost.	Check the domain of the recipient address or disable the authentication on the SMTP server if possible. SMTP authentication is currently not used in WinCC flexible Runtime.
70039	The syntax of the e-mail address is incorrect or contains illegal characters. The contents of the e-mail are discarded.	Check the e-mail address of the recipient.
70040	The syntax of the e-mail address is incorrect or contains illegal characters.	--
70041	The import of the user management was aborted due to an error. Nothing was imported.	Check your user management or transfer it again to the panel.
70042	The range of values of the tag was exceeded while executing the system function. The system function was not calculated.	Check and correct the calculation.
70043	The range of values of the tag was exceeded while executing the system function. The system function was not calculated.	Check and correct the calculation.
70044	An error occurred while sending the e-mails. The e-mails were not sent.	Check the SMTP settings and the error message in the system alarm.
70045	Cannot load a file required for encrypting the e-mail.	Update the operating system and Runtime.
70046	The server does not support encryption.	Select an SMTP server that supports encryption.
70047	The SSL versions of the HMI device and SMTP server may not be compatible.	Contact your network administrator or the operator of the SMTP server.

80000 - Log alarms

Number	Effect/causes	Remedy
80001	The log specified is filled to the size defined (in percent) and must be stored elsewhere.	Store the file or table by executing a 'move' or 'copy' function.
80002	A line is missing in the specified log.	--
80003	The copying process for logging was not successful. In this case, it is advisable to check any subsequent system alarms, too.	--

Appendix

A.6 System alarms

Number	Effect/causes	Remedy
80006	Since logging is not possible, this causes a permanent loss of the functionality.	In the case of databases, check whether the corresponding data source exists and start up the system again.
80009	A copying action has been completed successfully.	--
80010	Since the storage location was incorrectly entered in WinCC flexible, this causes a permanent loss of the functionality.	Configure the storage location for the respective log again and restart the system when the full functionality is required.
80012	Log entries are stored in a buffer. If the values are read to the buffer faster than they can be physically written (using a hard disk, for example), overloading may occur and recording is then stopped.	Archive fewer values. Or: Increase the logging cycle.
80013	The overload status no longer applies. Archiving resumes the recording of all values.	--
80014	The same action was triggered twice in quick succession. Since the process is already in operation, the action is only carried out once.	--
80015	This system alarm is used to report DOS or database errors to the user.	--
80016	The logs are separated by the system function "CloseAllLogs" and the incoming entries exceed the defined buffer size. All entries in the buffer are deleted.	Reconnect the logs.
80017	The number of incoming events cause a buffer overflow. This can be caused, for example, by several copying actions being activated at the same time. All copy jobs in the buffer are deleted.	Stop the copy action.
80019	The connection between WinCC flexible and all logs were closed, for example, after executing the system function "CloseAllLogs". Entries are written to the buffer and are then written to the logs when a connection is re-established. There is no connection to the storage location and the storage medium may be replaced, for example.	--
80020	The maximum number of simultaneously copy operations has been exceeded. Copying is not executed.	Wait until the current copying actions have been completed, then restart the last copy action.
80021	An attempt was made to delete a log which is still busy with a copy action. Deletion has not been executed.	Wait until the current copying actions have been completed, then restart the last action.
80022	An attempt was made to use the system function "StartSequenceLog" to start a sequence log for a log which is not configured as a sequence log. No sequence log file is created.	In the project, check <ul style="list-style-type: none"> • if the "StartSequenceLog" system function was properly configured. • if the tag parameters are properly provided with data on the HMI device.

Number	Effect/causes	Remedy
80023	An attempt was made to copy a log to itself. The log is not copied.	In the project, check <ul style="list-style-type: none"> • if the "CopyLog" system function was properly configured. • if the tag parameters are properly provided with data on the HMI device.
80024	The "CopyLog" system function does not allow copying when the target log already contains data ("Mode" parameter). The log is not copied.	Edit the "CopyLog" system function in the project if necessary. Before you initiate the system function, delete the destination log file.
80025	You have canceled the copy operation. Data written up to this point are retained. The destination log file (if configured) is not deleted. The cancellation is reported by an error entry \$RT_ERR\$ at the end of the destination log.	--
80026	This alarm is output after all logs are initialized. Values are written to the logs from then on. Prior to this, no entries are written to the logs, irrespective whether WinCC flexible Runtime is active or not.	--
80027	The internal Flash memory has been specified as the storage location for a log. This is not permissible. No values are written to this log and the log file is not created.	Configure "Storage Card" or a network path as the storage location.
80028	The alarm returns a status report indicating that the logs are currently being initialized. No values are logged until the alarm 80026 is output.	--
80029	The number of logs specified in the alarm could not be initialized. The logs are initialized. The faulty log files are not available for logging jobs.	Evaluate the additional system alarms related to this alarm. Check the configuration, the ODBC (Open Database Connectivity) and the specified drive.
80030	The structure of the existing log file does not match the expected structure. Logging is stopped for this log.	Delete the existing log data manually, in advance.
80031	The log in CSV format is corrupted. The log cannot be used.	Delete the faulty file.
80032	Logs can be assigned events. These are triggered as soon as the log is full. WinCC flexible Runtime is started and the log is already full, the event is not triggered. The log specified no longer logs data because it is full.	Close WinCC flexible Runtime delete the log, then restart WinCC flexible Runtime. Or: Configure a button which contains the same actions as the event and press it.
80033	"System Defined" is set in the data log file as the data source name. This causes an error. No data is written to the database logs, whereas the logging to the CSV logs works.	Reinstall SQL Sever 2005 Express.
80034	An error has occurred in the initialization of the logs. An attempt has been made to create the tables as a backup. This action was successful. A backup has been made of the tables of the corrupted log file and the cleared log was restarted.	No action is necessary. However, it is recommended to save the backup files or delete them in order to make the space available again.

Appendix

A.6 System alarms

Number	Effect/causes	Remedy
80035	An error has occurred in the initialization of the logs. An attempt has been made to create backups of the tables and this has failed. No logging or backup has been performed.	It is recommended to save the backups or to delete them in order to release memory.
80044	The export of a log was interrupted because Runtime was closed or due to a power failure. It was detected that the export needed to be resume when Runtime restarted.	The export resumes automatically.
80045	The export of a log was interrupted due to an error in the connection to the server or at the server itself.	The export is repeated automatically. Check: <ul style="list-style-type: none"> • The connection to the server. • If the server is running. • If there is enough free space on the server.
80046	The destination file could not be written while exporting the log.	Check whether there is enough space on the server and if you have permission to create the log file.
80047	The log could not be read while exporting it.	Check whether the storage medium is correctly inserted.
80049	The log could not be renamed while preparing to export it. The job can not be completed."	Check whether the storage medium is correctly inserted and if there is sufficient space on the medium.
80050	The log which shall be exported is not closed. The job can not be completed.	Make sure the "CloseAllLogs" system function is called before using the "ExportLog" system function. Change the configuration as required.
80051	The log to be copied contains an invalid checksum. The log was not copied.	Select a log with a valid checksum. The selected log may have been manipulated.
80052	The log cannot be read.	Check the log and the specified path.
80053	The closed log cannot be read.	Open the log.

90000 - FDA alarms

Number	Effect/causes	Remedy
90024	No operator actions can be logged due to lack of space on the storage medium for log. The operator action will therefore not be executed.	Make more space available by inserting an empty storage medium or swapping out the log files on the server using "ExportLog".
90025	No user actions can be logged because of error state of the archive. Therefore the user action will not be executed.	Check whether the storage medium is correctly inserted.
90026	No operator actions can be logged because the log is closed. The operator action will therefore not be executed.	Before further operator actions are carried out, the log must be opened again using the system function "OpenAllLogs". Change the configuration as required.
90028	The password you entered is incorrect.	Enter the correct password.
90029	Runtime was closed during ongoing operation (perhaps due to a power failure) or a storage medium in use is incompatible with Audit Trail. An Audit Trail is not suitable if it belongs to another project or has already been logged.	Ensure that you are using the correct storage medium.
90030	Runtime was closed during ongoing operation (perhaps due to a power failure).	--

Number	Effect/causes	Remedy
90031	Runtime was closed during ongoing operation (perhaps due to a power failure).	--
90032	Running out of space on the storage medium for log.	Make more space available by inserting an empty storage medium or swapping out the log files on the server using "ExportLog".
90033	No more space on the storage medium for log. As of now, no more operator actions requiring logging will be executed.	Make more space available by inserting an empty storage medium or swapping out the log files on the server using "ExportLog".
90039	You do not have the necessary authorization to perform this action.	Adapt or upgrade your authorizations.
90040	Audit Trail is switched off because of a forced user action.	Activate the "Audit Trail" again using the system function "StartLog".
90041	A user action which has to be logged has been executed without a logged on user.	A user action requiring logging should only be possible with permission. Change the configuration by setting a required authorization for the input object.
90044	A user action which has to be confirmed was blocked, because there is another user action pending.	Repeat the user action if necessary.
90048	The Audit Trail cannot be printed while data relevant to the audit is being logged.	Stop logging using the system function "StopLogging".
90049	Access to required file is not possible.	Check the network connection or the storage medium.
90056	The recipe was not imported because the file contains no checksum.	Select a file with a checksum. As an alternative, disable verification of the checksum by using the system function "ImportDataRecords".
90057	The recipe was not imported because the file contains an invalid checksum. The selected file may have been manipulated.	Select a file with a valid checksum.

110000 - Offline function alarms

Number	Effect/causes	Remedy
110000	The operating mode was changed. "Offline" mode is now set.	--
110001	The operating mode was changed. "Online" mode is now set.	--
110002	The operating mode was not changed.	Check the connection to the PLCs. Check whether the address area for the area pointer 88 "Coordination" in the PLC is available.
110003	The operating mode of the specified PLC was changed by the system function "SetConnectionMode". The operating mode is now "offline".	--
110004	The operating mode of the specified PLC has been changed by the system function "SetConnectionMode". The operating mode is now "online".	--

Appendix

A.6 System alarms

Number	Effect/causes	Remedy
110005	An attempt was made to use the system function SetConnectionMode to switch the specified PLC to "online" mode, although the entire system is in "offline" mode. This changeover is not allowed. The PLC remains in "offline" mode.	Switch the complete system to "online" mode, then execute the system function again.
110006	The content of the "project version" area pointer does not match the user version configured in WinCC flexible. WinCC flexible Runtime is therefore closed.	Check the following: <ul style="list-style-type: none"> • The project ID entered on the PLC. • The project ID entered in WinCC flexible.

120000 - Trend alarms

Number	Effect/causes	Remedy
120000	The trend is not displayed because you configured an incorrect axis to the trend or an incorrect trend.	Change the configuration.
120001	The trend is not displayed because you configured an incorrect axis to the trend or an incorrect trend.	Change the configuration.
120002	The trend is not displayed because the tag assigned attempts to access an invalid PLC address.	Check whether the data area for the tag exists in the PLC, the configured address is correct and the value range for the tag is correct.

130000 - System information alarms

Number	Effect/causes	Remedy
130000	The action was not executed.	Close all other programs. Delete files no longer required from the hard disk.
130001	The action was not executed.	Delete files no longer required from the hard disk.
130002	The action was not executed.	Close all other programs. Delete files no longer required from the hard disk.
130003	No data medium found. The operation is canceled.	Check, for example, if <ul style="list-style-type: none"> • The correct data medium is being accessed • The data medium is inserted
130004	The data medium is write-protected. The operation is canceled.	Check whether access has been made to the correct data carrier. Remove the write protection.
130005	The file is read only. The operation is canceled.	Check whether access has been made to the correct file. Edit the file attributes if necessary.
130006	Access to file failed. The operation is canceled.	Check, for example, if <ul style="list-style-type: none"> • The correct file is being accessed • The file exists • Another action is preventing simultaneous access to the file.
130007	The network connection is interrupted. Records cannot be saved or read over the network connection.	Check the network connection and eliminate the cause of error.

Number	Effect/causes	Remedy
130008	The storage card is not available. The specified data records cannot be saved to / read from the storage card.	Insert the storage card.
130009	The specified folder does not exist on the storage card. Any files saved to this directory are not backed up when you switch off the HMI device.	Insert the storage card.
130010	The maximum nesting depth can be exhausted when, for example, a value change in a script results in the call of another script and the second script in turn has a value change that results in the call of yet a further script etc. The configured functionality is not supported.	Check the configuration.
130013	The storage card is not available. The specified data records cannot be saved to / read from the storage card.	Insert the storage card.

140000 - Connection alarms chns7: Connection + device

Number	Effect/causes	Remedy
140000	An online connection to the PLC is established.	--
140001	The online connection to the PLC was shut down.	--
140003	No tag updating or writing is executed.	Check the connection and if the PLC is switched on. Check the parameter definitions in the Control Panel using "Set PG/PC interface". Restart the system.
140004	No tag update or write operations are executed because the access point or the module configuration is faulty.	Verify the connection and check whether the PLC is switched on. Check the access point or the module configuration (MPI, PPI, PROFIBUS) in the Control Panel with "Set PG/PC interface". Restart the system.
140005	No tag updating or writing is executed because the HMI device address is incorrect (possibly too high).	Use a different HMI device address. Verify the connection and check whether the PLC is switched on. Check the parameter definitions in the Control Panel using "Set PG/PC interface". Restart the system.
140006	No tag updating or writing is executed because the baud rate is incorrect.	Select a different baud rate in WinCC flexible (according to module, profile, communication peer, etc.).

Appendix

A.6 System alarms

Number	Effect/causes	Remedy
140007	Tags are not updated or written because the bus profile is incorrect (see %1). The following parameters could not be written to the registry: 1: Tslot 2: Tqui 3: Tset 4: MinTsdr 5: MaxTsdr 6: Trdy 7: Tid1 8: Tid2 9: Gap Factor 10: Retry Limit	Check the user-defined bus profile. Check the connection and if the PLC is switched on. Check the parameter definitions in the Control Panel using "Set PG/PC interface". Restart the system.
140008	No tag updating or writing is executed because baud rate is incorrect. The following parameters could not be written to the registry: 0: General error 1: Wrong version 2: Profile cannot be written to the registry. 3: The subnet type cannot be written to the registry. 4: The target rotation time cannot be written to the registry. 5: Faulty highest address (HSA).	Check the connection and if the PLC is switched on. Check the parameter definitions in the Control Panel using "Set PG/PC interface". Restart the system.
140009	Tags are not updated or written because the module for S7 communication was not found.	Reinstall the module in the Control Panel using "Set PG/PC interface".
140010	No S7 communication partner found because the PLC is shut down. DP/T: The option "PG/PC is the only master" is not set in the Control Panel under "Set PG/PC interface."	Switch the PLC on. DP/T: If only one master is connected to the network, disable "PG/PC is the only master" in "Set PG/PC interface". If several masters are connected to the network, enable these. Do not change any settings, for this will cause bus errors.
140011	No tag updating or writing is executed because communication is down.	Check the connection and that the communication partner is switched on.
140012	There is an initialization problem (e.g. when WinCC flexible Runtime was closed in Task Manager). Or: Another application (e.g. STEP7) with different bus parameters is active and the driver cannot be started with the new bus parameters (transmission rate, for example).	Restart the HMI device. Or: Run WinCC flexible Runtime, then start your other applications.
140013	The MPI cable is disconnected and, thus, there is no power supply.	Check the connections.
140014	The configured bus address is already in use by another application.	Edit the HMI device address in the PLC configuration.

Number	Effect/causes	Remedy
140015	Wrong transmission rate Or: Faulty bus parameters (e.g. HSA) Or: OP address > HSA or: Wrong interrupt vector (interrupt does not arrive at the driver)	Correct the relevant parameters.
140016	The hardware does not support the configured interrupt.	Change the interrupt number.
140017	The set interrupt is in use by another driver.	Change the interrupt number.
140018	The consistency check was disabled by SIMOTION Scout. Only a corresponding note appears.	Enable the consistency check with SIMOTION Scout and once again download the project to the PLC.
140019	SIMOTION Scout is downloading a new project to the PLC. Connection to the PLC is canceled.	Wait until the end of the reconfiguration.
140020	The version in the PLC and that of the project (FWX file) do not match. Connection to the PLC is canceled.	The following remedies are available: Download the current version to the PLC using SIMOTION Scout. Regenerate the project using WinCC flexible ES, close WinCC flexible Runtime and restart with a new configuration.

150000 - Connection alarms chnAS511: Connection

Number	Effect/causes	Remedy
150000	No more data is read or written. Possible causes: <ul style="list-style-type: none"> • The cable is defective. • The PLC does not respond, is defective, etc. • The wrong port is used for the connection. • System overload 	Ensure that the cable is plugged in, the PLC is operational, the correct port is being used. Restart the system if the system alarm persists.
150001	Connection is up because the cause of the interruption has been eliminated.	--

160000 - Connection alarms IVar (WinLC) / OPC: Connection

Number	Effect/causes	Remedy
160000	No more data is read or written. Possible causes: <ul style="list-style-type: none"> • The cable is defective. • The PLC does not respond, is defective, etc. • The wrong port is used for the connection. • System overload 	Ensure that the cable is plugged in, the PLC is operational, the correct port is being used. Restart the system if the system alarm persists.
160001	Connection is up because the cause of the interruption has been eliminated.	--
160010	No connection to the server because the server identification (CLS-ID) cannot be determined. Values cannot be read or written.	Check access rights.

Appendix

A.6 System alarms

Number	Effect/causes	Remedy
160011	No connection to the server because the server identification (CLS-ID) cannot be determined. Values cannot be read or written.	Check, for example, if <ul style="list-style-type: none"> • The server name is correct. • The computer name is correct. • The server is registered.
160012	No connection to the server because the server identification (CLS-ID) cannot be determined. Values cannot be read or written.	Check, for example, if <ul style="list-style-type: none"> • The server name is correct. • The computer name is correct. • The server is registered. Note for advanced users: Interpret the value from HRESULT.
160013	The specified server was started as InProc server. This has not been released and may possibly lead to incorrect behavior because the server is running in the same process area as the WinCC flexible Runtime software.	Configure the server as OutProc Server or Local Server.
160014	Only one OPC server project can be started on a PC/MP. An alarm is output when an attempt is made to start a second project. The second project has no OPC server functionality and cannot be located as an OPC server by external sources.	Do not start a second project with OPC server functionality on the computer.

170000 - S7 dialog alarms

Number	Effect/causes	Remedy
170000	S7 diagnostics events are not indicated because it is not possible to log on to the S7 diagnostics functions at this device. The service is not supported.	--
170001	The S7 diagnostics buffer cannot be viewed because communication with the PLC is shut down.	Set the PLC to online mode.
170002	The S7 diagnostics buffer cannot be viewed because reading of the diagnostics buffer (SSL) was canceled with error.	--
170003	An S7 diagnostics event cannot be visualized. The system returns internal error %2.	--
170004	An S7 diagnostics event cannot be visualized. The system returns an internal error of error class %2, error number %3.	--
170007	It is not possible to read the S7 diagnostics buffer (SSL) because this operation was canceled with an internal error of class %2 and error code %3.	--

180000 - Misc/common alarms

Number	Effect/causes	Remedy
180000	A component/OCX received configuration data with a version ID which is not supported.	Install a newer component.
180001	System overload because too many actions running in parallel. Not all the actions can be executed, some are rejected.	Several remedies are available: <ul style="list-style-type: none"> • Generate the alarms at a slower rate (polling). • Initiate scripts and functions at greater intervals. If the alarm appears more frequently: Restart the HMI device.
180002	The screen keyboard could not be activated. Possible causes: "TouchInputPC.exe" was not registered due to a faulty Setup.	Install WinCC flexible Runtime again.

190000 - Tag alarms

Number	Effect/causes	Remedy
190000	It is possible that the tag is not updated.	--
190001	The tag is updated after the cause of the last error state has been eliminated (return to normal operation).	--
190002	The tag is not updated because communication with the PLC is down.	Select the system function "SetOnline" to go online.
190004	The tag is not updated because the configured tag address does not exist.	Check the configuration.
190005	The tag is not updated because the configured PLC type does not exist for this tag.	Check the configuration.
190006	The tag is not updated because it is not possible to map the PLC type in the data type of the tag.	Check the configuration.
190007	The tag value is not modified because the connection to the PLC is interrupted or the tag is offline.	Set online mode or reconnect to the PLC.
190008	The threshold values configured for the tag have been violated, for example, by <ul style="list-style-type: none"> • A value entered • A system function • A script 	Observe the configured or current threshold values of the tag.
190009	An attempt has been made to assign the tag a value which is outside the permitted range of values for this data type. For example, a value of 260 was entered for a byte tag or a value of -3 for an unsigned word tag.	Observe the range of values for the data type of the tags.

Appendix

A.6 System alarms

Number	Effect/causes	Remedy
190010	Too many values are written to the tag (for example, in a loop triggered by a script). Values are lost because only up to 100 actions are saved to the buffer.	The following remedies are available: <ul style="list-style-type: none"> • Increase the time interval between multiple write actions. • Do not use an array tag longer than 6 words when you configure an acknowledgment on the HMI device using "Acknowledgment HMI".
190011	Possible cause 1: The value entered could not be written to the configured PLC tag because the high or low limit was exceeded. The system discards the entry and restores the original value. Possible cause 2: The connection to the PLC was interrupted.	Make sure that the value entered lies within the range of values of the control tags. Check the connection to the PLC.
190012	It is not possible to convert a value from a source format to a target format, for example: An attempt is being made to assign a value to a counter that is outside the valid, PLC-specific value range. A tag of the type Integer should be assigned a value of the type String.	Check the range of values or the data type of the tags.
190013	The user has entered a string that is longer than the tag. The string is automatically shortened to the permitted length.	Only enter strings that do not exceed the permitted tag length.

190100 - Area pointer alarms

Number	Effect/causes	Remedy
190100	The area pointer is not updated because the address configured for this pointer does not exist. Type 1 Warnings 2 Errors 3 PLC acknowledgment 4 HMI device acknowledgment 5 LED mapping 6 Trend request 7 Trend transfer 1 8 Trend transfer 2 No.: Consecutive number displayed in WinCC flexible ES.	Check the configuration.
190101	The area pointer is not updated because it is not possible to map the PLC type to the area pointer type. Parameter type and no.: see alarm 190100	--
190102	The area pointer is updated after the cause of the last error state has been eliminated (return to normal operation). Parameter type and no.: See alarm 190100.	--

200000 - PLC coordination alarms

Number	Effect/causes	Remedy
200000	Coordination is not executed because the address configured in the PLC does not exist/is not set.	Change the address or set up the address in the PLC.
200001	Coordination is canceled because the write access to the address configured in the PLC is not possible.	Change the address or set the address in the PLC at an area which allows write access.
200002	Coordination is not carried out at the moment because the address format of the area pointer does not match the internal storage format.	Internal error
200003	Coordination can be executed again because the last error state is eliminated (return to normal operation).	--
200004	The coordination may not be executed.	--
200005	No more data is read or written. Possible causes: <ul style="list-style-type: none"> • The cable is defective. • The PLC does not respond, is defective, etc. • System overload 	Ensure that the cable is plugged in and the PLC is operational. Restart the system if the system alarm persists.

Appendix

A.6 System alarms

210000 - PLC job alarms

Number	Effect/causes	Remedy
210000	Jobs are not processed because the address configured in the PLC does not exist/has not been set up.	Change the address or set up the address in the PLC.
210001	Jobs are not processed because read/write access to the address configured in the PLC is not possible.	Change the address or set up the address in the PLC in an area which allows read/write access.
210002	Jobs are not executed because the address format of the area pointer does not match the internal storage format.	Internal error
210003	The job buffer is processed again because the last error status has been eliminated (return to normal operation).	--
210004	It is possible that the job buffer will not be processed.	--
210005	A control request with an illegal number was initiated.	Check the PLC program.
210006	An error occurred while attempting to execute the control request. As a result, the control request is not executed. Observe the next/previous system alarms.	Check the parameters of the control request. Recompile the configuration.

220000 - WinCC channel adapter alarms

Number	Effect/causes	Remedy
220001	The tag is not downloaded because the associated communication driver / HMI device does not support the download of Boolean/discrete data types.	Change the configuration.
220002	The tag is not downloaded because the associated communication driver / HMI device does not support write access to the data type BYTE.	Change the configuration.
220003	The communication driver cannot be loaded. The driver may not be installed.	Install the driver by reinstalling WinCC flexible Runtime.
220004	Communication is down and no update data is transferred because the cable is not connected or defective etc.	Check the connection.
220005	Communication is up.	--
220006	The connection between the specified PLC and the specified port is active.	--

Number	Effect/causes	Remedy
220007	The connection to the specified PLC is interrupted at the specified port.	Check whether <ul style="list-style-type: none"> • The cable is plugged in • The PLC is OK • The correct port is used • Your configuration is OK (port parameters, protocol settings, PLC address). Restart the system if the system alarm persists.
220008	The communication driver cannot access or open the specified port. The port may be in use by another application or the port used is not available on the destination device. There is no communication with the PLC.	Close all the applications which access this port and restart the computer. Use another port of the system.

230000 - View alarms

Number	Effect/causes	Remedy
230000	The value entered could not be accepted. The system discards the entry and restores the previous value. Either <ul style="list-style-type: none"> • The value range has been exceeded • Illegal characters have been entered • The maximum permitted number of users has been exceeded. 	Enter a practical value or delete any unneeded users.
230002	The currently logged in user has not the required authorization. The system therefore discards the input and restored the previous value.	Log on as a user with appropriate authorization.
230003	Changeover to the specified screen failed because the screen is not available/configured. The current screen remains selected.	Configure the screen and check the screen selection function.
230005	The value range of the tag has been exceeded in the I/O field. The original value of the tag is retained.	Observe the range of values for the tag when entering a value.
230100	During navigation in the web browser, the system returned a message which may be of interest to the user. The web browser continues to run but may not (fully) show the new page.	Navigate to another page.
230200	The connection to the HTTP channel was interrupted due to an error. This error is explained in detail by another system alarm. Data is no longer exchanged.	Check the network connection. Check the server configuration.
230201	The connection to HTTP channel was established. Data is exchanged.	--

Appendix

A.6 System alarms

Number	Effect/causes	Remedy
230202	<p>WININET.DLL has detected an error. This error is usually generated if it is not possible to connect to the server or if the server denies access because the client could not authenticate itself.</p> <p>A rejected server certificate could also cause a communication error in secure SSL connections.</p> <p>For details, refer to the error text in the alarm. This text is always output in the language of your Windows installation, as it is returned by the Windows operating system.</p> <p>Process values are not exchanged.</p> <p>The part of the alarm which is returned by the Windows operating system may not be displayed, for example "An error has occurred." WININET.DLL returns the following error: Number: 12055 Text:HTTP: <no error text available>."</p>	<p>Depending on the cause:</p> <p>When an attempt to connect fails or a timeout error occurs:</p> <ul style="list-style-type: none"> • Check the network connection and the network. • Check the server address. • Check whether the WebServer is actually running on the destination station. <p>Faulty authorization:</p> <ul style="list-style-type: none"> • The configured user name and/or password do not match those on the server. Establish consistency <p>When the server certificate is rejected: Certificate signed by an unknown CA ():</p> <ul style="list-style-type: none"> • Either ignore this item in your project, or • Install a certificate that has been signed with a root certificate known to the client computer. <p>The date of the certificate is invalid:</p> <ul style="list-style-type: none"> • Either ignore this item in your project, or • Install a certificate with a valid date on the server. <p>Invalid CN (Common Name or Computer Name):</p> <ul style="list-style-type: none"> • Either ignore this item in your project, or • Install a certificate with a name that corresponds to that of the server address.
230203	<p>Although a connection can be made to the server, the HTTP server refuses to connect because</p> <ul style="list-style-type: none"> • WinCC flexible Runtime is not running on the server or • The HTTP channel is not supported (503 Service unavailable). <p>Other errors can only occur if the Webserver does not support the HTTP channel. The language of the alarm text depends on the Webserver.</p> <p>Data is not exchanged.</p>	<p>Error 503 Service unavailable:</p> <p>Check if WinCC flexible Runtime is running on the server and if the HTTP channel is supported.</p>
230301	<p>An internal error has occurred. An English text explains the error in more detail. This may be caused by insufficient memory.</p> <p>OCX does not work.</p>	--
230302	<p>The name of the remote server cannot be resolved.</p> <p>The attempt to connect failed.</p>	<p>Check the configured server address.</p> <p>Check whether the DNS service is available on the network.</p>
230303	<p>The remote server is not running on the addressed computer.</p> <p>Wrong server address.</p> <p>The attempt to connect failed.</p>	<p>Check the configured server address.</p> <p>Check whether the remote server is running on the target computer.</p>
230304	<p>The remote server on the addressed computer is incompatible with VNCOCX.</p> <p>The attempt to connect failed.</p>	<p>Use a compatible remote server.</p>

Number	Effect/causes	Remedy
230305	The authentication has failed because the password is incorrect. The attempt to connect failed.	Configure the correct password.
230306	Error in the connection to the remote server. This may occur as a result of network problems. The attempt to connect failed.	Check whether <ul style="list-style-type: none"> • The bus cable is plugged in • There are network problems.
230307	The connection to the remote server was shut down because <ul style="list-style-type: none"> • The remote server was shut down, or • The user instructed the server to close all connections. The connection is closed.	--
230308	This alarm provides information on the connection status. An attempt is made to connect.	--

240000 - Authorization alarms

Number	Effect/causes	Remedy
240000	WinCC flexible Runtime is operating in demo mode. You have no authorization or your authorization is corrupted.	Install the authorization.
240001	WinCC flexible Runtime is operating in demo mode. Too many tags are configured for the installed version.	Load an adequate authorization / power pack.
240002	WinCC flexible Runtime is operating with a time-limited emergency authorization.	Restore the full authorization.
240004	Error while reading the emergency authorization. WinCC flexible Runtime is operating in demo mode.	Restart WinCC flexible Runtime, install the authorization or repair the authorization (see Commissioning Instructions Software Protection).
240005	The Automation License Manager has detected an internal system fault. Possible causes: <ul style="list-style-type: none"> • A corrupt file • A defective installation • No free space for the Automation License Manager etc. 	Reboot the HMI device or PC. If this does not solve the problem, remove the Automation License Manager and install it again.

Appendix

A.6 System alarms

250000 - S7 Force alarms

Number	Effect/causes	Remedy
250000	The tag in the specified line in "Status Force" is not updated because the address configured for this tag is not available.	Check the set address and then verify that the address is set up in the PLC.
250001	The tag in the specified line in "Status Force" is not updated because the PLC type configured for this tag does not exist.	Check the set address.
250002	The tag in the specified line in "Status Force" is not updated because it is not possible to map the PLC type in the tag type.	Check the set address.
250003	An attempt to connect to the PLC failed. The tags are not updated.	Check the connection to the PLC. Check that the PLC is switched on and is online.

260000 - Password system alarms

Number	Effect/causes	Remedy
260000	An unknown user or an unknown password has been entered in the system. The current user is logged off from the system.	Log on to the system as a user with a valid password.
260001	The logged in user does not have sufficient authorization to execute the protected functions on the system.	Log on to the system as a user with sufficient authorization.
260002	This alarm is triggered by the system function "TrackUserChange".	--
260003	The user has logged off from the system.	--
260004	The user name entered into the user view already exists in the user management.	Select another user name because user names have to be unique in the user management.
260005	The entry is discarded.	Enter a shorter user name.
260006	The entry is discarded.	Use a shorter or longer password.
260007	The logon timeout value entered is outside the valid range of 0 to 60 minutes. The new value is discarded and the original value is retained.	Enter a logon timeout value between 0 and 60 minutes.
260008	An attempt was made to read a PTProRun.pwl file created with ProTool V 6.0 in WinCC flexible. Reading the file was canceled due to incompatibility of the format.	--
260009	You have attempted to delete the user "Admin" or "PLC User". These users are fixed components of the user management and cannot be deleted.	If you need to delete a user, because perhaps you have exceeded the maximum number permitted, delete another user.
260012	The passwords entered in the "Change Password" dialog and the confirmation field are not identical. The password has not been changed. User will be logged off.	You have to log on to the system again. Then enter the identical password twice to be able to change the password.

Number	Effect/causes	Remedy
260013	The password entered in the "Change Password" dialog is invalid because it is already in use. The password has not been changed. User will be logged off.	You have to log on to the system again. Then enter a new password that has not been used before.
260014	You have tried unsuccessfully to log on three times in succession. You will be locked out and assigned to group no. 0.	You can log on to the system with your correct password. Only an administrator can change the assignment to a group.
260024	The password you entered does not meet the necessary security guidelines.	Enter a password that contains at least one number.
260025	The password you entered does not meet the necessary security guidelines.	Enter a password that contains at least one special character.
260028	Upon system start-up, an attempt to log on, or when trying to change the password of a SIMATIC log-on user, the system attempts to access the SIMATIC Logon Server. If attempting to log on, the new user is not logged in. If a different user was logged on before, then this user is logged off.	Check the connection to the SIMATIC Logon Server and its configuration; for example: 1. Port number 2. IP address 3. Server name 4. Functional transfer cable Or use a local user.
260030	The SIMATIC Logon user could not change his password on the SIMATIC Logon Server. The new password may not comply with the password regulations on the server or the user does not have the right to change his password. The old password remains and the user is logged off.	Log in again and choose a different password. Check the password rules on the SIMATIC Logon Server.
260033	The action change password or log on user could not be carried out.	Check the connection to the SIMATIC Logon Server and its configuration; for example: 1. Port number 2. IP address 3. Server name 4. Functional transfer cable Or use a local user.
260034	The last logon operation has not yet ended. A user action or a logon dialog can therefore not be called. The logon dialog is not opened. The user action is not executed.	Wait until the logon operation is complete.
260035	The last attempt to change the password was not completed. A user action or a logon dialog can therefore not be called. The logon dialog is not opened. The user action is not executed.	Wait until the procedure is complete.
260036	There are insufficient licenses on the SIMATIC Logon Server. The logon is not authorized.	Check the licensing on the SIMATIC Logon Server.

Appendix

A.6 System alarms

Number	Effect/causes	Remedy
260037	There is no license on the SIMATIC Logon Sever. A logon is not possible. It is not possible to log on via the SIMATIC Logon Server, only via a local user.	Check the licensing on the SIMATIC Logon Server.
260040	The system attempts to access the SIMATIC Logon Server upon system start-up or when trying to change the password. If attempting to log on, the new user is not logged in. If a different user was logged on before, then this user is logged off.	Check connection to the domain and its configuration in the Runtime security settings editor. Or use a local user.
260043	It was not possible to log the user on to the SIMATIC Logon Server. The user name or the password could be incorrect or the user does not have sufficient rights to log on. The new user is not logged in. If a different user was logged on before, then this user is logged off.	Try again. If necessary, check the password data on the SIMATIC Logon Server.
260044	It was not possible to log the user on to the SIMATIC Logon Server as his account is blocked. The new user is not logged in. If a different user was logged on before, then this user is logged off.	Check the user data on the SIMATIC Logon Server.
260045	The SIMATIC Logon user is not associated to any or several groups. The new user is not logged in. If a different user was logged on before, then this user is logged off.	Check the user data on the SIMATIC Logon Server and the configuration in your WinCC flexible project. A user may only be assigned to one group.

270000 - System alarms

Number	Effect/causes	Remedy
270000	A tag is not indicated in the alarm because it attempts to access an invalid address in the PLC.	Check whether the data area for the tag exists in the PLC, the configured address is correct and the value range for the tag is correct.
270001	There is a device-specific limit as to how many alarms may be queued for output (see the operating instructions). This limit has been exceeded. The view no longer contains all the alarms. However, all alarms are written to the alarm buffer.	--
270002	The view shows alarms of a log for which there is no data in the current project. Wildcards are output for the alarms.	Delete older log data if necessary.
270003	The service cannot be set up because too many devices want to use this service. A maximum of four devices may execute this action.	Reduce the number of HMI devices which want to use the service.

Number	Effect/causes	Remedy
270004	Access to persistent buffer is not possible. Alarms cannot be restored or saved.	If the problems persist at the next startup, contact Customer Support (delete Flash).
270005	Persistent buffer damaged: Alarms cannot be restored.	If the problems persist at the next startup, contact Customer Support (delete Flash).
270006	Project modified: Alarms cannot be restored from the persistent buffer.	The project was generated and transferred new to the HMI device; The error should no longer occur when the device starts again.
270007	A configuration problem is preventing the restore (a DLL is missing, a directory is unknown, etc.).	Update the operating system and then transfer your project again to the HMI device.

280000 - DPHMI alarms Connection

Number	Effect/causes	Remedy
280000	Connection is up because the cause of the interruption has been eliminated.	--
280001	No more data is read or written. Possible causes: <ul style="list-style-type: none"> • The cable is defective • The PLC does not respond, is defective, etc. • The wrong port is used for the connection • System overload 	Check whether <ul style="list-style-type: none"> • The cable is plugged in • The PLC is OK • The correct port is used. Restart the system if the system alarm persists.
280002	The connection used requires a function block in the PLC. The function block has responded. Communication is now enabled.	--
280003	The connection used requires a function block in the PLC. The function block has not responded.	Check whether <ul style="list-style-type: none"> • The cable is plugged in • The PLC is OK • The correct port is used. Restart the system if the system alarm persists. Remedy depends on the error code: <ol style="list-style-type: none"> 1: The function block must set the COM bit in the response container. 2: The function block must not set the ERROR bit in the response container. 3: The function block must respond within the specified time (timeout). 4: Go online to the PLC.
280004	The connection to the PLC is interrupted. There is no data exchange at present.	Check the connection parameters in WinCC flexible. Ensure that the cable is plugged in, the PLC is operational, the correct port is being used. Restart the system if the system alarm persists.

Appendix

A.6 System alarms

290000 - Recipe system alarms

Number	Effect/causes	Remedy
290000	The recipe tag could not be read or written. It is assigned the start value. The alarm can be entered in the alarm buffer for up to four more failed tags if necessary. After that, alarm 290003 is output.	Check in the configuration that the address has been set up in the PLC.
290001	An attempt has been made to assign a value to a recipe tag which is outside the value range permitted for this type. The alarm can be entered in the alarm buffer for up to four more failed tags if necessary. After that, alarm 290004 is output.	Observe the value range for the tag type.
290002	It is not possible to convert a value from a source format to a target format. The alarm can be entered in the alarm buffer for up to four more failed recipe tags if necessary. After that, alarm 290005 is output.	Check the value range or type of the tag.
290003	This alarm is output when alarm number 290000 is triggered more than five times. In this case, no further separate alarms are generated.	Check in the configuration that the tag addresses have been set up in the PLC.
290004	This alarm is output when alarm number 290001 is triggered more than five times. In this case, no further separate alarms are generated.	Observe the value range for the tag type.
290005	This alarm is output when alarm number 290002 is triggered more than five times. In this case, no further separate alarms are generated.	Check the value range or type of the tag.
290006	The threshold values configured for the tag have been violated by values entered.	Observe the configured or current threshold values of the tag.
290007	There is a difference between the source and target structure of the recipe currently being processed. The target structure contains an additional data recipe tag which is not available in the source structure. The data recipe tag specified is assigned its start value.	Insert the specified data recipe tag in the source structure.
290008	There is a difference between the source and target structure of the recipe currently being processed. The source structure contains an additional data recipe tag which is not available in the target structure and therefore cannot be assigned. The value is rejected.	Remove the specified data recipe tag in the specified recipe from the project.
290010	The storage location configured for the recipe is not permitted. Possible causes: Illegal characters, write protection, data carrier out of space or does not exist.	Check the configured storage location.

Number	Effect/causes	Remedy
290011	The record with the specified number does not exist.	Check the source for the number (constant or tag value).
290012	The recipe with the specified number does not exist.	Check the source for the number (constant or tag value).
290013	An attempt was made to save a record under a record number which already exists. The action is not executed.	The following remedies are available: <ul style="list-style-type: none"> • Check the source for the number (constant or tag value). • First, delete the record. • Change the "Overwrite" function parameter.
290014	The file specified to be imported could not be found.	Check: <ul style="list-style-type: none"> • The file name • Ensure that the file is in the specified directory.
290020	Alarm reporting that the download of records from the HMI device to the PLC has started.	--
290021	Alarm reporting that the download of records from the HMI device to the PLC was completed.	--
290022	Alarm reporting that the download of records from the HMI device to the PLC was canceled due to an error.	Check in the configuration whether: <ul style="list-style-type: none"> • The tag addresses are configured in the PLC • The recipe number exists • The record number exists • The "Overwrite" function parameter is set
290023	Alarm reporting that the download of records from the PLC to the HMI device has started.	--
290024	Alarm reporting that the download of records from the PLC to the HMI device was completed.	---
290025	Alarm reporting that the download of records from the PLC to the HMI device was canceled due to an error.	Check in the configuration whether: <ul style="list-style-type: none"> • The tag addresses are configured in the PLC • The recipe number exists • The record number exists • The "Overwrite" function parameter is set
290026	An attempt has been made to read/write a record although the record is not free at present. This error may occur in the case of recipes for which downloading with synchronization has been configured.	Set the record status to zero.
290027	Unable to connect to the PLC at present. As a result, the record can neither be read nor written. Possible causes: No physical connection to the PLC (no cable plugged in, cable is defect) or the PLC is switched off.	Check the connection to the PLC.
290030	This alarm is output after you selected screen which contains a recipe view in which a record is already selected.	Reload the record from the storage location or retain the current values.
290031	While saving, it was detected that a record with the specified number already exists.	Overwrite the record or cancel the action.

Appendix

A.6 System alarms

Number	Effect/causes	Remedy
290032	While exporting records it was detected that a file with the specified name already exists.	Overwrite the file or cancel the process.
290033	Confirmation request before deleting records.	--
290040	A record error with error code %1 that cannot be described in more detail occurred. The action is canceled. It is possible that the record was not installed correctly on the PLC.	Check the storage location, the record, the "Data record" area pointer and if necessary, the connection to the PLC. Restart the action after a short time. If the error persists, contact Customer Support. Forward the relevant error code to Customer Support.
290041	A record or file cannot be saved because the storage location is full.	Delete files no longer required.
290042	An attempt was made to execute several recipe actions simultaneously. The last action was not executed.	Trigger the action again after waiting a short period.
290043	Confirmation request before storing records.	--
290044	The data store for the recipe has been destroyed and is deleted.	--
290050	Alarm reporting that the export of records has started.	--
290051	Alarm reporting that the export of records was completed.	--
290052	Alarm reporting that the export of records was canceled due to an error.	Ensure that the structure of the records at the storage location and the current recipe structure on the HMI device are identical.
290053	Alarm reporting that the import of records has started.	--
290054	Alarm reporting that the import of records was completed.	--
290055	Alarm reporting that the import of records was canceled due to an error.	Ensure that the structure of the records at the storage location and the current recipe structure on the HMI device are identical.
290056	Error when reading/writing the value in the specified line/column. The action was canceled.	Check the specified line/column.
290057	The tags of the recipe specified were toggled from "offline" to "online" mode. Each change of a tag in this recipe is now immediately downloaded to the PLC.	--
290058	The tags of the specified recipe were toggled from "offline" to "online" mode. Modifications to tags in this recipe are no longer immediately transferred to the PLC but must be transferred there explicitly by downloading a record.	--
290059	Alarm reporting that the specified record was saved.	--
290060	Alarm reporting that the specified record memory was cleared.	--

Number	Effect/causes	Remedy
290061	Alarm reporting that clearing of record memory was canceled due to an error.	--
290062	The record number is above the maximum of 65536. This record cannot be created.	Select another number.
290063	This occurs with the system function "ExportDataRecords" when the parameter "Overwrite" is set to No. An attempt has been made to save a recipe under a file name which already exists. The export is canceled.	Check the "ExportDataRecords" system function.
290064	Alarm reporting that the deletion of records has started.	--
290065	Alarm reporting that the deletion of records has successfully completed.	--
290066	Confirmation request before deleting records.	--
290068	Security request to confirm if all records in the recipe should be deleted.	--
290069	Security request to confirm if all records in the recipe should be deleted.	--
290070	The record specified is not in the import file.	Check the source of the record number or record name (constant or tag value).
290071	During the editing of record values, a value was entered which exceeded the low limit of the recipe tag. The entry is discarded.	Enter a value within the limits of the recipe tag.
290072	When editing record values, a value was entered which exceeds the high limit of the recipe tag. The entry is discarded.	Enter a value within the limits of the recipe tag.
290073	An action (e.g. saving a record) failed due to an unknown error. The error corresponds to the status alarm IDS_OUT_CMD_EXE_ERR in the large recipe view.	--
290074	While saving, it was detected that a record with the specified number already exists but under another name.	Overwrite the record, change the record number or cancel the action.
290075	A record with this name already exists. The record is not saved.	Please select a different record name.

Appendix

A.6 System alarms

Number	Effect/causes	Remedy
290110	The default values could not be set due to an error.	--
290111	The Recipes subsystem cannot be used. Recipe views have no content and recipe-specific functions will not be performed. Possible causes: <ul style="list-style-type: none"> An error occurred while transferring the recipes. The recipe structure was changed in ES. When the project was downloaded again, the recipes were not transferred with it. This means that the new configuration data is not being transferred to the old recipes on the device. 	Transfer the project to the device again, together with the recipes (the corresponding check box in the Transfer dialog must be checked).

300000 - Alarm_S alarms

Number	Effect/causes	Remedy
300000	Faulty configuration of process monitoring (e.g. using PDiag or S7 Graph): More alarms are queued than specified in the specifications of the CPU. No further ALARM_S alarms can be managed by the PLC and reported to the HMI devices.	Change the PLC configuration.
300001	ALARM_S is not registered on this PLC.	Select a controller that supports the ALARM_S service.

310000 - Report system alarms

Number	Effect/causes	Remedy
310000	An attempt is being made to print too many reports in parallel. Only one log file can be output to the printer at a given time; the print job is therefore rejected.	Wait until the previous active log was printed. Repeat the print job if necessary.
310001	An error occurred on triggering the printer. The report is either not printed or printed with errors.	Evaluate the additional system alarms related to this alarm. Repeat the print job if necessary.

320000 - Alarms

Number	Effect/causes	Remedy
320000	The movements have already been indicated by another device. The movements can no longer be controlled.	Deselect the movements on the other display units and select the motion control screen on the required display unit.
320001	The network is too complex. The faulty addresses cannot be indicated.	View the network in STL.

Number	Effect/causes	Remedy
320002	No diagnosable alarm message (error) selected. The unit associated with the alarm message could not be selected.	Select a diagnostics alarm from the ZP_ALARM alarm screen.
320003	No alarm message (error) exists for the selected unit. The detail view cannot visualize any networks.	Select the defective unit from the overview screen.
320004	The required signal states could not be read by the PLC. The faulty addresses cannot be found.	Check the consistency between the configuration on the display unit and the PLC program.
320005	The project contains ProAgent elements which are not installed. ProAgent diagnostic functions cannot be performed	In order to run the project, install the optional ProAgent package.
320006	You have attempted to execute a function which is not supported in the current constellation.	Check the type of the selected unit.
320007	No error-triggering addresses were found on the networks. ProAgent cannot indicate any faulty addresses.	Switch the detail screen to STL layout mode and check the status of the addresses and exclusion addresses.
320008	The diagnostic data stored in the configuration are not synchronized with those in the PLC. ProAgent can only indicate the diagnostic units.	Transfer the project to the HMI device again.
320009	The diagnostic data stored in the configuration are not synchronized with those in the PLC. The diagnostic screens can be operated as usual. ProAgent may be unable to show all diagnostic texts.	Transfer the project to the HMI device again.
320010	The diagnostic data stored in the configuration are not synchronized with those in STEP7. The ProAgent diagnostics data is not up-to-date.	Transfer the project to the HMI device again.
320011	A unit with the corresponding DB number and FB number does not exist. The function cannot be executed.	Check the parameters of the "SelectUnit" function and the units selected in the project.
320012	The "Step sequence mode" dialog is no longer supported.	Use the ZP_STEP step sequence screen from the corresponding standard project for your project. Instead of calling the Overview_Step_Sequence_Mode function, call the "FixedScreenSelection" function using ZP_STEP as the screen name.
320014	The selected PLC cannot be evaluated for ProAgent. The Alarm view assigned to the "EvaluateAlarmDisplayFault" system function could not be found.	Check the parameters of the "EvaluateAlarmDisplayFault" system function.

Appendix

A.6 System alarms

330000 - GUI alarms

Number	Effect/causes	Remedy
330022	Too many dialogs are open on the HMI device.	Close all dialogs you do not require on the HMI device.
330026	The password will expire after the number of days shown.	Enter a new password.

350000 - GUI alarms

Number	Effect/causes	Remedy
350000	PROFIsafe packages have not arrived within the necessary period. There is a communication problem with the F-CPU. RT is terminated.	Check the WLAN connection.
350001	PROFIsafe packages have not arrived within the necessary period. There is a communication problem with the F-CPU. The PROFIsafe connection is re-established.	Check the WLAN connection.
350002	An internal error has occurred. Runtime is terminated.	Internal error
350003	Feedback concerning the connection established with the F-CPU. The Emergency-Off buttons are active immediately.	--
350004	PROFIsafe communication was set and the connection was cleared. The Runtime can be terminated. The Emergency-Off buttons are deactivated immediately.	--
350005	Incorrect address configured for the F-slave. No PROFIsafe connection.	Check and modify the address of the F slave in WinCC flexible ES.
350006	The project has started. At the start of the project, the enabling buttons must be checked for functionality.	Press the two enabling buttons one after another in the "Enable" and "Panic" positions.
350008	The wrong number of fail-safe buttons was configured. No PROFIsafe connection.	Change the number of fail-safe buttons in the project.
350009	The device is in Override mode. It may no longer be possible to detect the location because transponder detection fails.	Exit Override mode.
350010	Internal error: The device has no fail-safe buttons.	Send the device back. Worldwide contact person

B

Abbreviations

ANSI	American National Standards Institution
CPU	Central Processing Unit
CSV	Comma Separated Values
CTS	Clear To Send
DC	Direct Current
DCD	Data Carrier Detect
DHCP	Dynamic Host Configuration Protocol
DIL	Dual-in-Line (electronic chip housing design)
DNS	Domain Name System
DP	Distributed I/O
DSR	Data Set Ready
DTR	Data Terminal Ready
IO	Input and Output
EAP	Extensible Authentication Protocol
ESD	Components and modules endangered by electrostatic discharge
EMC	Electromagnetic compatibility
EN	European standard
ES	Engineering System
ESD	Components and modules endangered by electrostatic discharge
GND	Ground
HF	High Frequency
HMI	Human Machine Interface
IEC	International Electronic Commission
IEEE	Institute of Electrical and Electronics Engineers
IF	Interface
IP	Internet Protocol
IWLAN	Industrial Wireless Local Area Network
LAN	Local Area Network
LED	Light Emitting Diode
MAC	Media Access Control
MOS	Metal Oxide Semiconductor
MPI	Multipoint Interface (SIMATIC S7)
MS	Microsoft
MTBF	Mean Time Between Failures
n. c.	Not connected
OP	Operator Panel

Abbreviations

PC	Personal Computer
PG	Programming device
PPI	Point-to-Point Interface (SIMATIC S7)
RAM	Random Access Memory
PELV	Protective Extra Low Voltage
RJ45	Registered Jack Type 45
RTS	Request to send
RxD	Receive Data
SAR	Specific absorption rate
SD Card	Security Digital Card
SELV	Safety Extra Low Voltage
SIL	Safety Integrity Level
SP	Service Pack
PLC	Programmable Logic Controller
SSID	Service set identifier
STN	Super Twisted Nematic
Sub-D	Subminiature D (plug)
TAB	Tabulator
TCP/IP	Transmission Control Protocol/Internet Protocol
TFT	Thin Film Transistor
TIA	Totally Integrated Automation
TKIP	Temporal Key Integrity Protocol
TLS	Transport Layer Security
TxD	Transmit Data
UL	Underwriter's Laboratory
USB	Universal Serial Bus
WAP	Wireless Access Point
WLAN	Wireless Local Area Network
WEP	Wired Equivalent Privacy
WINS	Windows Internet Naming Service
WPA	Wi-Fi Protected Access

Glossary

"Transfer" mode

"Transfer" is an operating mode of the HMI device in which an executable project is transferred from the configuration PC to an HMI device.

Access point

See Wireless access point.

Ad hoc network

An ad hoc network in information technology refers to a wireless network between two or more mobile devices, for which no fixed infrastructure is necessary. This technique is used with Bluetooth, for example, to spontaneously link mobile phones. Ad hoc mode is also possible for WLAN.

Alarm logging

Output of user-specific alarms to a printer, in parallel to their output to the HMI device screen.

Alarm, acknowledging an

Acknowledgment of an alarm confirms that it has been noted.

Alarm, coming in

Moment at which an alarm is triggered by the PLC or HMI device.

Alarm, going out

Moment at which the initiation of an alarm is reset by the PLC.

Alarm, user-specific

An alarm is configurable object. A user-specific alarm designates a certain operating status of the plant connected to the HMI device via the PLC.

Automation system

An automation system is a controller of the SIMATIC S7 series, such as a SIMATIC S7-300.

Bootloader

Used to start the operating system. Automatically started when the HMI device is switched on. After the operating system has been loaded, the Loader opens.

Configuration PC

A configuration PC is a programming device or PC on which HMI projects are created for a plant with a configuration software.

CRC

Test values contained in a safety message frame can be backed up as follows:

- The validity of the process values contained in the safety message frame
- The accuracy of the assigned address relationships
- The safety-related parameters

Display duration

Defines whether a system alarm is displayed on the HMI device and the duration of the display.

Engineering software

Use the configuration software to create a project for process visualization. WinCC flexible, for example, is such a configuration software.

Event

An event is configurable object. Functions are triggered by defined incoming events. Events which can be assigned to a button include "Press" and "Release", for example.

Fail-safe

Ability of a technical system to remain in a safe operating state or switch to another safe operating state immediately after certain failures occur.

Fail-safe operation

Operating mode of the HMI device in which safety-related communication can be performed via safety message frames.

Fail-safe system, F system

A fail-safe system is used to control production processes by achieving a safe operating state immediately after shutdown. In other words, fail-safe systems control processes in which an immediate shutdown does not endanger people or the environment. Fail-safe systems are used in plants requiring higher levels of safety.

Field array

A field is configurable object. A reserved area is used for the input and output of values.

Flash memory

Non-volatile memory with EEPROM chips, used as mobile storage medium or as memory module installed permanently on the motherboard.

Half Brightness Life Time

Time period after which the brightness reaches 50% of the original value. The specified value is dependent on the operating temperature.

HMI device

An HMI device is used for operation and monitoring of production processes. The operating states of the plant are visually depicted on the HMI device. Operator controls on the HMI device enable intervention in the production process of the plant.

HMI device image

An HMI device image is a file that can be transferred from the configuration PC to the HMI device. An HMI device image contains the operating system for a specific HMI device and the runtime components required for the executable project file.

HMI screen

The HMI screens on the HMI device visualize the production process. The HMI screens are configured with WinCC flexible and will be available on the HMI device once the project has been transferred to the HMI device.

Infotext

Infotext is configurable object. It displays information about other objects within a project. Infotext for an alarm, for example, may contain information on the cause of the fault and troubleshooting routines.

Infrastructure mode

An infrastructure network is a wireless LAN, which enables communication among the various devices through a central wireless access point. The terminal devices must log on with their MAC address to the wireless access point and get an IP address assigned, if a DHCP server responds to the requesting device.

IO field

An IO field is configurable object. It enables values to be entered on the HMI device and transferred to the controller, and values to be output from the controller.

IO field, symbolic

A symbolic IO field is configurable object. It enables values to be entered on the HMI device and transferred to the controller, and values to be output from the controller. Contains a list of default entries from which one can be selected.

IT system

This is a particular type of ground connection in a distribution system in electrical engineering for increased resistance to isolation errors.

Object

An object is a configuration component of a project, for example, a screen, alarm or IO field.

Operating element

Component of a project used to enter values and trigger functions. A operator control is a button, for example.

PLC

A PLC is a general term for devices and systems with which the HMI device communicates, for example SIMATIC S7.

PLC job

A PLC job triggers a function for the PLC at the HMI device.

Process image

The process image is a memory area in the controller which the HMI device and controller access together. At the beginning of the cyclic control program the signal states of the inputs of the HMI device are transferred to the controller via the process input images, PII. At the end of the cyclic program the process image of the outputs, PIQ is transferred as a signal state to the HMI device.

Process visualization

Visualization of technical processes by means of text and graphic elements. Configured plant screens allow operator intervention in active production processes by means of the input and output of data.

PROFINET

Within the framework of Totally Integrated Automation, PROFINET represents an enhancement of the following bus systems:

- PROFIBUS DP as well-established fieldbus
- Industrial Ethernet as the communication bus on the device level

The experience gained from both systems has been and continues to be integrated in PROFINET. PROFINET as an Ethernet-based automation standard from PROFIBUS International defines a vendor-independent communications and engineering model.

PROFINET IO controller

Device used to address the connected IO devices. This means the IO controller exchanges input and output signals with assigned field devices. The IO controller is often a PLC.

PROFINET IO device

A distributed field device that is assigned to one of the IO controllers (e.g. remote IO, valve terminals, frequency converters, switches)

PROFINET IO

As part of PROFINET, PROFINET IO is a communication solution that is used to implement modular, distributed applications.

PROFINET IO allows you to create automation solutions of the type with which you are familiar from PROFIBUS. PROFINET IO is implemented by the PROFINET standard for automation devices on the one hand, and on the other hand by the STEP 7 engineering software. This means that you have the same application view in STEP 7 regardless of whether you configure PROFINET or PROFIBUS devices. Programming your user program is essentially the same for PROFINET IO and PROFIBUS DP if you use the extended blocks and system status lists for PROFINET IO.

PROFIsafe

A fail-safe bus profile from PROFINET for communication between the safety program and the F-I/O in a fail-safe system.

PROFIsafe address

Every F-I/O has a PROFIsafe address. The F-I/O uses this address to receive safety message frames from the F-CPU or send safety message frames to the F-CPU.

Project

A project is the result of a configuration using an configuration software. The project normally contains several HMI screens, in which plant-specific objects are embedded. If it has been configured in WinCC flexible, the project is saved in a project file with the file name extension, ".hmi".

You need to distinguish between the project on the configuration PC and the runtime project on an HMI device. A project on the configuration PC may have more languages than can be managed on the HMI device. The project on the configuration PC can also be set up for different HMI devices. Only the runtime project that has been generated for the respective HMI device can be transferred to it.

Project file

File generated from the runtime project file for use on the HMI device. The project file is usually not transferred and remains on the configuration PC.

The file name extension of a project file is ".hmi".

Project file, compressed

Compressed format of the project file. The compressed project file can be transferred together with the runtime project file to the respective HMI device. Backtransfer must be enabled on the configuration PC for this purpose. The compressed project file is usually saved to an external storage medium.

The file extension of a compressed project file is ".pdz".

Proof-test interval

A period after which a component must be set to a safe state. Either the component is replaced by an unused component or full, error-free operation must be demonstrated.

Recipe

A recipe is a configurable component of a project. A recipe assembles variables in a fixed data structure. The corresponding data structure can be filled with data in the configuration software or on an HMI device.

Using a recipe ensures that all assigned data is transferred to the PLC synchronously during the transfer of a data record.

Runtime

You need the Runtime software to run a project you have created with WinCC flexible on a PC or HMI device.

Runtime project file

A runtime project file is a file that is generated from the finished project file for a specific HMI device based on the configuration. It can therefore only be run on a particular HMI device type. The runtime project file is transferred to the corresponding HMI device and used there to operate and monitor a production process.

The file extension of a runtime project file is "fwx".

Safe operating state

An operating state of a visualization unit which achieves safety. This is defined by the absence of safety-related failures. It is defined by the acceptably low risk achieved with the protective measures taken against potential safety-related failures.

The basic principle of the safety concept in a fail-safe system is the existence of a safe operating state for all process variables.

Safety function

A safety system integrated in F-I/Os and F-CPUs, enabling them to be used in fail-safe systems. According to IEC 61508, a safety function is implemented by a safety mechanism to ensure that the plant is kept in a safe operating state or brought into a safe operating state in the event of a fault (user safety function).

Safety Integrity Level

Safety Integrity Level (safety class) according to IEC 61508 and prEN 50129.

The higher the safety integrity level, the greater the measures required for fail-safe operation in order to avoid systematic errors and bring systematic errors and random equipment failure under control.

Safety-related communication

Communication used for fail-safe data communication.

Screen

See HMI screen.

Screen object

A screen object is a configurable object used to display or operate the plant, for example, a rectangle, I/O field or alarm view.

STEP 7

STEP 7 is the programming software for SIMATIC S7, SIMATIC C7 and SIMATIC WinAC PLCs.

System alarm

A system alarm is assigned to the "System" alarm class. A system alarm refers to internal states on the HMI device and the PLC.

Tab sequence

The tab order is the configured order of the objects that are accessed by successively pressing the "TAB" key.

Tag

Defined memory location to which values can be written to and read from. This can be done from the PLC or the HMI device. Based on whether the tag is interconnected with the PLC or not, we distinguish between "external" tags (process tags) and "internal" tags.

Transfer

Transfer of a runtime project from the configuration PC to the HMI device.

Transponder

A transponder is a – usually wireless – communication, display or control device that receives incoming signals and automatically responds to them. The term transponder is derived from transmitter and responder. Transponders can be passive or active.

Wireless access point

A wireless access point is an electronic device that acts as an interface for wireless communication devices. Terminal devices provide a wireless connection to the wireless access point via wireless adapter, which in turn is connected by cable to an installed communication network.

Index

"

"Override" mode
 Activate, 262
 Disabling, 262

/

/Audit, 25

A

Absorption rate, 52
Acceptance, 241
 Effective range, 243
 F-CPU, 242
 F-I/O, 242
 Plant, 241
 Safety program, 242
 Transponder, 243
Accessories
 Accessory kit, 23
Accessory kit
 Charging station, 20
 Transponder, 23
Acknowledge
 Alarm, 309
 Error alarm, 309
Activate
 "Override" mode, 262
Activating override
 Application case, 369
Ad hoc network, 59
Adapting
 Project, 211
Address assignment
 TCP/IP network, 175
Admin, 291, 292
Alarm, 304
 Acknowledge, 309
 Alarm indicator, 306
 Display, 306
 Editing, 310
 Functional scope, 26
Alarm buffer, 305
 Functional scope, 26

Alarm class, 304
 Icon, 307
Alarm event, 304
Alarm group, 305
Alarm indicator, 306
Alarm line, 306
Alarm log, 305
Alarm report, 305
Alarm view, 306
 Extended, 307
 Simple, 307
Alarm window, 308
ALARM_S, 26
Ambient conditions, 55
 climatic RFID tag, 57
 Climatic, charging station, 57
 Climatic, HMI device, 56
 Climatic, transponder, 57
 Storage, 54
 Testing, 56
 Transport, 54
Application case
 Activating override, 369
 Communication errors with integrated HMI device, 375
 Communication errors with logged on HMI device, 377
 Detecting the effective range, 364
 Enabling button askew, 379
 Enabling button defective, 381
 Exiting the effective range, 366
 Integrating the HMI device, 363
 Internal error, 378
 Log off at the effective range, 367
 Log on at the effective range, 365
 Logging off the machine, 374
 Logon, 372
 Switch on the HMI device., 362
Applications
 Mobile Panel 277F IWLAN, 15
Approvals, 42
 Australia, 43
 UL approval, 43
 Wireless approval, 45
Australia
 Approvals, 43
Authentication, 74
Authorization, 285

- Automatic
 - Transfer, 216
- Automation License Manager, 235
- Automation system
 - Fail-safe, 38
- B**
- Backlighting
 - Reducing, 163
- Backtransfer, 214, 217
- Backup, 185, 187, 213, 220, 221, 286
 - Registry information, 157
 - Temporary files, 157
 - To external storage device, 185
 - With ProSave, 221
 - With WinCC flexible, 221
- Backup time
 - Internal clock, 343
- BAT 1
 - LED, 123
- BAT 2
 - LED, 123
- Battery
 - Inserting, 81
 - Used, 5
- Bit assignment
 - Direct key, 114
 - Illuminated pushbutton, 118
 - Key-operated switch, 117
- Booting, 142
- Brightness
 - Changing, 137
- Byte assignment
 - Direct keys, 113
- C**
- Calibrating
 - Touch screen, 140
- Cancel
 - Transfer, 99
- Care, 336
- CE approval, 42
- Certificate, 45
- Certificates Stores, 183
- Changing
 - Brightness, 137
 - User data, 291
- Character repeat
 - Screen keyboard, 138
- Charge
 - Electrostatic, 359
- Charge level
 - Rechargeable battery, 159
- Charging station
 - Accessory kit, 20
 - Charging compartment, 122
 - Clearance, 67
 - Configuration, 20
 - Connecting, 78
 - EMC-compliant installation, 51
 - LED display, 123
 - Lock, 124
 - Main dimensions, 339
 - Mounting location, 66
 - Mounting position, 77
- Charging status
 - Display, 93
 - Vibration alarm, 159
- Checklist
 - Configuration, 197
 - Fail-safe, 192
 - Information security, 73
- Checksum
 - Determining, 244
- Clearance
 - Charging station, 67
- Climatic environmental conditions, 54
- Closing
 - Remote control, 302
- Column sequence
 - Alarm view, 308
- COM
 - LED, 103
- Commissioning, 213, 237, 247
- Communication
 - HMI device and controller, 194
- Communication error, 40, 251, 303
 - Application case, 377
- Communication link with controller
 - Number, 25
- Compatibility conflict, 220, 224
- Computer name
 - For network operation, 174
 - Unique, 174
- Computers
 - Addressing, 173
- Condensation, 54
- Configuration
 - Checklist, 197
- Configuration example, 386, 399
- Configuration graphic

- Configuring PC, 95
 - PLC on Mobile Panel, 94
 - Printer, 97
- Configuration phase, 30
- Configure
 - Screen keyboard, 136
- Configuring PC, 30
 - Configuration graphic, 95
 - Connecting, 95
- Connecting
 - Configuring PC, 95
 - PLC, 94
 - Printer, 97
- Connector
 - Installing, 78
 - Structure, 78
- Contact person, 5
- Control Panel
 - Open, 131
 - Operating, 133
 - Password protection, 128
 - Screen keyboard, 134
- Convention
 - Style, 4
 - Term, 4
- Cookie, 182
- CRC, 244
- Creating
 - Recipe data record, 320, 326
 - Users, 289

D

- Data channel
 - Enabling, 171
 - Locking, 171
 - Parameter assignment, 171
- Data flow, 314
- Data record list, 316, 325
- Date
 - Setting, 155
 - Synchronizing, 156
- Date format, 162
- Date/time properties, 155
- Default Gateway, 176
- Degree of protection, 58
- Delay time
 - Setting, 167
- Delete
 - Certificate, 183
 - Recipe data record, 321, 327
 - Users, 292

- Design variations, 16
- Detecting the effective range
 - Application case, 364
- Determining
 - Checksum, 244
- DHCP, 175
- Diagnostics
 - HMI device, 251
 - Internal error, 252
 - Reading information, 251
- Direct key, 112
 - Bit assignment, 114
 - Byte assignment, 113
 - Configuring, 275
 - Evaluation, 113
 - Functional scope, 28
- Disabling
 - "Override" mode, 262
 - SecureMode, 131
- Discrepancy error
 - Enabling button askew, 379
 - Enabling button defective, 381
- Display
 - Alarm, 306
 - Charging status, 93
 - Infotext, 308
 - Specifications, 342
- Displaying
 - Displaying information about the HMI device, 158
 - Infotext, 280
 - Memory information, 165
 - System information, 165
- Disposal, 5
- Disturbance variable
 - Pulse-shaped, 51
 - Sinusoidal, 52
- DNS, 176
 - Server, 173
- Documentation
 - SIMATIC complete, 5
- Double-click
 - Setting, 139

E

- Editing
 - Alarm, 310
 - Recipe data record, 327
- Editor
 - System alarms, 417
- Effective range, 33
 - Acceptance, 243

- Bridging time, 91
 - defining, 67
- Detect, 256
- Determining, 257
- Forming, 61
- Leaving, 258
- Logoff, 259
- Logon, 258
- Planning, 62
- Quality, 62
- RFID tag, 65
- Setting up, 59
- Transponder, 62
- Effective range name, 282
- Effective range quality, 283
 - Application, 283
- Effective ranges
 - Testing, 245
- Electrostatic charge, 359
- Element list, 316, 325
- EMC
 - Guideline, 42
- EMERGENCY STOP, 40
- EMERGENCY STOP button
 - Not active, 49
 - Not available, 49
 - Operating, 48, 108
 - Out of service, 49
 - Release, 108
 - Requirements, 48
- Emission, 47, 52
- Enabling
 - SecureMode, 131
- Enabling button, 50, 109
 - Panic activation, 110
 - Switch settings, 110
- Enabling device, 50
- Encryption protocol, 182
- Entering
 - By means of function key, 292
 - Recipe data record, 331
- Entering data, 279
- Equipment failure, 54
- Error
 - Internal, 303
- Error alarm
 - Acknowledge, 309
- Error code
 - Discrepancy error, 252
- Error code message
 - Internal error, 252
- Error display

- Red, 303
- Ethernet settings
 - IP address, 175
- Evaluation
 - Direct key, 113
 - Handwheel, 116
 - LED function key, 116
- Example of an application
 - Components, 401
 - Flowchart, 388, 400
 - HW Config, 401
 - Safety program, 405
- Exiting the effective range
 - Application case, 366
- Exporting
 - Recipe data record, 329
- Extended alarm view, 307
- Extended recipe view, 315
- Extended user view, 287

F

- F_Block_ID, 196
- F_Dest_Add, 195
- F_FB_MP, 201
- F_FB_RNG_n, 204
- F_Par_Version, 196
- F_SIL, 196
- F_Source_Add, 196
- F_WD_Time, 195
- Factory setting, 226
 - With ProSave, 230
 - With WinCC flexible, 227
- Fail-safe
 - Automation system, 38
 - Checklist, 192
 - Operation, 38, 361
- Fail-safe block, 196, 198
- Fail-safe operation
 - Software, 25
 - Specifications, 343
- F-application block, 198
- FB
 - Interconnect, 200
- FCC approval, 43
- F-CPU
 - Acceptance, 242
- Feedback
 - Optical, 274
- F-FB, 196
- F-I/O
 - Acceptance, 242

- Fixing pocket
 - Main dimensions, 340
- Front view, 16, 337
- Function
 - Testing, 111
- Function keys
 - Global function assignment, 292
 - Input via, 292
 - Labeling, 118
 - Local function assignment, 292
- Functional scope
 - Alarm buffer, 26
 - ALARM_S, 26
 - Alarms, 26
 - Device-specific, 29
 - Graphics list, 26
 - Infotext, 28
 - Limit value monitoring, 26
 - Log, 27
 - Recipe, 27
 - RFID tag system, 29
 - Safety, 28
 - Scaling, 26
 - Screen, 27
 - Tag, 26
 - Text list, 26
 - Transponder system, 29
- Functions
 - Additional, 28
- G**
- Gauge, 293
- Global rampdown, 40
- Graphics list
 - Functional scope, 26
- GSDML file, 193
- H**
- Handwheel
 - Evaluate incremental values, 117
 - Evaluation, 116
 - Operating, 111
 - Reaction time, 115
- Hidden SSID, 73
- High frequency radiation, 42
- HMI device
 - alignment, 256
 - Design variations, 16
 - Displaying information, 158
 - During operation, 253
 - Enabling button, 109
 - Front view, 16
 - Holding, 120, 121
 - Integrating, 254
 - Logoff, 39
 - Logon, 39
 - Operating, 120
 - Ports, 87
 - Rear view, 17
 - Remove, 269
 - Restart, 142
 - Side view, 17
 - Specifications, 342
 - Switch off, 100
 - Switching on, 99
 - Usage, 47
- HMI Input Panel
 - Options, 136
- Homepage
 - Internet, 180
- HW Config
 - HMI device display, 193
- I**
- I/O
 - F_FB_MP, 202
 - F_FB_RNG_n, 206
- I/O DB, 201
- Identification, 177
- Illuminated pushbutton
 - Bit assignment, 118
 - Operating, 112
 - Usage, 117
- Illustration, 4
- Importing
 - Certificate, 183
 - Recipe data record, 330
- Industry Portal, 5
- Information
 - For the HMI device, 158
- Information security, 72
 - Checklist, 73
- Infotext
 - Display, 308
 - Displaying, 280
 - Functional scope, 28
- Input
 - F_FB_MP, 202
 - F_FB_RNG_n, 206
- Input device

- Specifications, 342
- Inserting
 - Battery, 81
- Installation
 - EMC-compatible, 51
 - RFID tag, 82
 - Transponder, 79
- Installation according to the instructions, 41
- Installing
 - Connector, 78
 - WinCC flexible option, 213, 232, 234
- insulation resistance, 58
- Integrating, 39, 254
 - Application case, 363
- Interfaces
 - Specifications, 343
- Internal clock, 343
- Internal error, 303
 - Application case, 378
 - Diagnostics, 252
- Internet
 - E-mail, 177
 - Homepage, 180
- Internet browser, 180
- Internet Explorer, 129
- Internet options
 - Advanced, 182
 - Connection, 181
 - General, 180
 - Privacy, 182
- IP address
 - Ethernet, 175
- iPCF, 36
- iPCF-MC, 36
- iWLAN, 31, 34

K

- Key control
 - Trend view, 297
- Keyboard
 - External, 130
- Key-operated switch
 - Bit assignment, 117
 - Operating, 112
 - Usage, 117
- Knowledge
 - Required, 3

L

- Labeling
 - Function keys, 118
- Labeling strips, 18
 - Attaching, 119
 - Dimensions, 119
 - Printing, 118
- Language change
 - Functional scope, 28
- Layout
 - Slider control, 294
 - Sm@rtClient view, 300
- Leaving the effective range
 - Vibration alarm, 159
- LED
 - BAT 1, 123
 - BAT 2, 123
 - COM, 103
 - Meaning, 103
 - POWER, 123
 - PWR, 103
 - RNG, 103
 - SAFE, 103
- LED display
 - Charging station, 123
 - Main battery, 93
 - Mobile Panel, 103
- LED function key
 - Bit assignment, 116
 - Evaluation, 116
- License key, 235
 - Transferring, 213, 236
 - Transferring back, 213, 236
- Limit value monitoring
 - Functional scope, 26
- Loader
 - Buttons, 128
- Local rampdown, 40
- Log
 - Functional scope, 27
- Log off at the effective range
 - Application case, 367
- Logging on at the effective range
 - Application case, 365
- Logoff
 - Application case, 374
 - Effective range, 259
 - HMI device, 39
 - Users, 289
- Logoff time, 286
- Logon
 - Application case, 372

Effective range, 258
HMI device, 39
Users, 288
Logon data, 177

M

MAC address, 168
Main battery, 18
 Changing, 91
 Insert, 92
 LED display, 93
Main dimensions
 Charging station, 339
 Fixing pocket, 340
 Mobile Panel 277F IWLAN, 337
 Spacer, 341
 Transponder, 340
Main rechargeable battery, 280
 Charge level, 159
 Charging in the charging compartment, 122
 Temperature, 159
Maintenance, 335
Manual
 Production sequence, 332
 Scope, 3
 Transfer, 215
Measures
 Organizational, 253
Mechanical ambient conditions, 54
Memory
 Specifications, 342
Memory card, 19
 Inserting, 88
 Unplug, 89
Memory information
 Displaying, 165
Memory management, 189
Mobile Panel
 Applications, 15
 LED display, 103
 Ports, 87
Mobile Panel 277F IWLAN
 Main dimensions, 337
Mode
 Override, 33, 69, 260
Module diagnostics, 251
moisture protection, 58
Monitoring mode
 Sm@rtClient view, 300
Monitoring time, 194
Mounting

 Intended, 41
Mounting location
 Charging station, 66
 Selecting, 68
 Signal lamp, 69
Mounting position
 Charging station, 77
Mouse
 External, 130
Multi-key operation, 273, 293
Multimedia card, 87

N

Name server, 176
Network ID, 177
Network operation
 Computer name, 174
Network parameters
 Setting, 175
Network&Dial-Up Connections, 175
Notice of protected rights, 4
Number format, 162
Number of characters
 For password, 286
 For user, 286
 For user view, 286

O

Object
 Battery, 280
 Effective range (RFID) name, 283
 Effective range name, 282
 Effective range quality, 283
 WLAN quality, 281
 Zone name, 284
 Zone quality, 284
Office location, 5
Offline
 Operating mode, 212
 Recipe tag, 318
 Testing, 219
Online
 Operating mode, 212
 Recipe tag, 318
 Testing, 219
OP properties
 Battery, 159
 Device, 142, 158
 Memory monitoring, 189

- Persistent storage, 157
 - Touch, 140
 - Operating
 - Control Panel, 133
 - EMERGENCY STOP button, 48, 108
 - Feedback, 274
 - Handwheel, 111
 - HMI device, 120
 - Illuminated pushbutton, 112
 - Key-operated switch, 112
 - Recipe menu, 326
 - Recipe screen, 319, 326
 - Recipe view, 319
 - Slider control, 294
 - Switches, 295
 - With external keyboard, 273
 - With external mouse, 273
 - Operating instructions
 - Purpose, 3
 - Operating mode
 - Changing, 212
 - Offline, 212
 - Online, 212
 - Transfer, 99, 212
 - Operating safety
 - Standards, 48
 - Operating state
 - Safe, 38
 - Operating system
 - Parameter assignment, 128
 - Updating, 213, 224
 - Updating using ProSave, 225
 - Updating with WinCC flexible, 225
 - Operation
 - Fail-safe, 38, 361
 - Operation feedback, 274
 - Operator control
 - Recipe view, 319
 - Simple recipe view, 325
 - Optical feedback, 274
 - Option
 - Installing, 213
 - Installing with ProSave, 234
 - Installing with WinCC flexible, 232
 - Removing, 213
 - Removing with ProSave, 235
 - Removing with WinCC flexible, 233
 - Options, 25
 - Output
 - F_FB_MP, 203
 - F_FB_RNG_n, 207
 - Override, 33
 - Mode, 69
 - Switches, 209
- P**
- Panic activation
 - Enabling button, 110
 - Parameter assignment
 - Data channel, 171
 - Operating system, 128
 - Password, 285
 - Backup, 286
 - Number of characters, 286
 - Removing, 144
 - Restoring, 286
 - Setting up, 144
 - Password list, 285
 - Password properties, 143
 - Password protection, 128
 - Setting up, 143
 - Permissions in remote operation, 301
 - PII
 - Start address, 195, 204, 208
 - Pin assignment
 - RJ45 socket, 345
 - USB socket, 345
 - PIQ
 - Start address, 195, 204, 208
 - Planning
 - Effective range, 62
 - Number of RFID tags, 65
 - Transponder assignment, 63, 64
 - Zone, 63
 - Plant
 - Acceptance, 241
 - Shutdown response, 40
 - PLC, 25
 - Configuration graphic, 94
 - Connecting, 94
 - Number, 25
 - Reading recipe data record, 323, 328
 - Released, 25
 - Transferring recipe data record, 323, 329
 - PLC_User, 291, 292
 - Ports, 87
 - POWER
 - LED, 123
 - Power failure, 220
 - Power management
 - Levels, 105
 - Power Save 1, 105, 162
 - Power Save 2, 105, 162

- Power supply, 347
 - Specifications, 343
 - Power supply unit
 - Connecting, 98
 - Printer
 - Configuration graphic, 97
 - Connecting, 97
 - Printer connection
 - Setting, 160
 - Printer properties, 160
 - Printing
 - Labeling strips, 118
 - Production sequence
 - Manual, 332
 - PROFINET
 - Addressing computers, 173
 - PROFINET IO
 - Disabling direct keys, 168
 - Enabling direct keys, 168
 - PROFIsafe, 25
 - Loading the address, 170
 - Parameter, 194
 - Project
 - Adapting, 211
 - Offline testing, 219
 - Reuse, 211
 - Screen keyboard, 277
 - Testing online, 219
 - Transferring, 213
 - Project file
 - Compressed, 214
 - Protected trademark, 4
 - Protection against ingress of solid foreign bodies, 58
 - Protection class
 - HMI device, 58
 - Protection zone, 34, 36, 69
 - Planning, 71
 - Setting up, 69
 - Protective foil, 18
 - Protective measure
 - Static electricity, 360
 - Protocol, 25
 - Released, 25
 - Proxy server
 - HMI device, 181
 - Internet Explorer, 129
 - PWR
 - LED, 103
- R**
- Radiation
 - High frequency, 42
 - Radio interference, 47
 - Emission, 52
 - Radio network, 59
 - Rampdown
 - Global, 40
 - Local, 40
 - Reaction time
 - Handwheel, 115
 - Reading
 - Diagnostic information, 251
 - Reading out
 - Recipe data record, 323, 328
 - Rear view, 17
 - Rechargeable battery
 - Used, 5
 - Rechargeable buffer battery
 - Charge level, 159
 - Temperature, 159
 - Recipe, 311
 - Control, 312
 - Data flow, 314
 - Data record, 312
 - Field of application, 311
 - Functional scope, 27
 - Recipe screen, 315
 - Recipe view, 315
 - Synchronizing tags, 322
 - Recipe data record
 - Creating, 320, 326
 - Delete, 321, 327
 - Editing, 327
 - Entering, 331
 - Exporting, 329
 - Importing, 330
 - Reading from PLC, 323, 328
 - Synchronize with PLC, 321
 - Transferring to PLC, 323, 329
 - Recipe list, 316, 325
 - Recipe menu
 - Operating, 326
 - Recipe screen, 316
 - Operating, 319, 326
 - Overview, 316
 - Recipe tag
 - Offline, 318
 - Online, 318
 - Synchronizing, 318, 322
 - Recipe view, 315
 - Editing, 324
 - Extended, 315
 - Menu items, 325

- Operating, 319
 - Operator control, 319, 325
 - Simple, 316
 - Recommissioning, 213, 237, 247
 - Recycling, 5
 - Red error display, 303
 - Regional and language settings, 162
 - Regional setting, 162
 - Registered trademark, 4
 - Registry information
 - Backup, 157
 - Remote control
 - Closing, 302
 - Forcing permission, 301
 - Start, 301
 - Remove, 39, 269
 - Removing
 - Password, 144
 - WinCC flexible option, 213, 233, 235
 - Replacement key set, 18
 - Reset button, 87
 - Resetting
 - To factory settings, 96
 - Response time, 194
 - Restoring, 213, 220, 222, 223, 286
 - From external storage device, 187
 - With ProSave, 223
 - With WinCC flexible, 222
 - Restoring factory settings, 96, 213
 - RFID tag
 - Effective range, 35
 - Installation, 82
 - planning the mapping, 65
 - Planning the number, 65
 - RFID tag system, 35
 - Risk analysis, 48
 - Risk evaluation
 - Special mode, 50
 - RNG
 - LED, 103
 - Rotary coding switch
 - Transponder, 79
 - RSS approval, 44
 - Ruler
 - Trend view, 295
- S**
- S7 Distributed Safety, 196
 - SAFE
 - LED, 103
 - Safety
 - Functional scope, 28
 - Standards, 48
 - Safety instruction
 - Changed tag name, 322
 - Multi-key operation, 273
 - Recipe data record in the background, 316
 - Safety program, 196, 198, 199
 - Interconnecting FBs, 200
 - Sample cycle time, 115
 - SAR, 52
 - Scaling
 - Functional scope, 26
 - Scope
 - Manual, 3
 - Scope of delivery, 15, 77
 - Screen
 - Functional scope, 27
 - Screen keyboard
 - Adjust size, 135, 278
 - Change layout, 135, 278
 - Character repeat, 138
 - Configure, 136
 - Entering data, 279
 - For Control Panel, 134
 - For project, 277
 - Move, 134, 278
 - Representation types, 134, 277
 - Screen saver, 163
 - Setting, 163
 - SecureMode
 - Disabling, 131
 - Enabling, 131
 - Security system, 34, 36, 285
 - Suitable, 71
 - Selecting
 - Mounting location, 68
 - Service, 5
 - Service pack
 - HMI device, 18
 - Setting
 - Date, 155
 - Date format, 162
 - Delay time, 167
 - Double-click, 139
 - ID, 81
 - Language, 276
 - Network parameters, 175
 - Number format, 162
 - Printer connection, 160
 - Regional data, 162
 - Screen saver, 163
 - SMTP server, 178

- Storage location, 166
- Time, 155
- Time format, 162
- Setting language, 276
- Setting up
 - Effective range, 59
 - Password, 144
 - Password protection, 143
 - Protection zone, 69
 - Zone, 63
- Shutdown, 40
- Shutdown response, 255, 263
 - Plant, 40
- Side view, 17, 338
- Signal lamp
 - Mounting location, 69
- SIMATIC Logon, 285
- SIMATIC S7, 25
- Simple alarm view, 307
- Simple recipe view, 316
 - Menu items, 325
 - Operator control, 325
- Simple user view, 287
- Slider control, 294
- Sm@rtAccess, 25
- Sm@rtClient view, 300
 - Monitoring mode, 300
 - Usage, 300
- Sm@rtService, 25
- SMTP server, 177
 - Setting, 178
- Software
 - Fail-safe operation, 25
 - For fail-safe mode, 191
- Software options, 25
- Sort order
 - Alarm view, 308
- Spacer
 - Main dimensions, 341
- Special mode
 - Risk evaluation, 50
- Specifications
 - Display, 342
 - Fail-safe operation, 343
 - HMI device, 342
 - Input device, 342
 - Interfaces, 343
 - Main battery, 347
 - Memory, 342
 - Power supply, 343
- SSID
 - Hidden, 73
- Standard
 - EMC testing, 45
 - TÜV, 46, 47
- Start
 - HMI device, 142
- Static electricity
 - Protective measures, 360
- Status Force, 298
 - Touch operation, 299
- STEP 7
 - HW Config, 194
- Stop
 - Category 0, 49
 - Category 1, 49
- Storage location
 - Setting, 166
- Storage medium
 - Restoring from external, 187
 - Saving to external, 185
- Subnet Mask, 176
- Support
 - Technical, 5
- Support Request, 5
- Switch off
 - HMI device, 100
- Switch setting
 - Enabling button, 110
- Switches, 295
- Switching on
 - Application case, 362
 - HMI device, 99
- Synchronizing
 - Date and time, 156
 - Recipe tag, 318, 322
- System alarm
 - Configuring events, 417
 - Meaning, 419, 420, 421, 423, 426, 427, 428, 429, 431, 432, 433, 435, 436, 437, 439, 440, 442, 443, 444, 448, 450
 - Parameters, 417
- System alarms
 - Display, 417
- System functions, 112
- System information
 - Displaying, 165
- System properties
 - Device name, 174
 - General, 165
 - Memory, 165

T

- Tag, 32
 - Functional scope, 26
- Task planner
 - Functional scope, 28
- TCP/IP address, 175
- Technical specifications
 - Power supply, 347
 - Weight, 347
- Technical support, 5
- Technical Support, 5
- Temperature
 - Rechargeable battery, 159
- Temporary files
 - Backup, 157
- Test
 - Mechanical, HMI device, 56
- Testing
 - Effective ranges, 245
 - Function, 111
- Text list
 - Functional scope, 26
- Time
 - Setting, 155
 - Synchronizing, 156
- Time format, 162
- Time zone
 - Setting, 155
- Touch operation
 - Trend view, 297
- Touch screen, 130
 - Calibrating, 140
- Trademark, 4
- Training center, 5
- Transfer, 212, 213, 214
 - Automatic, 216
 - Cancel, 99
 - Manual, 215
- Transfer settings, 171
 - Directories, 166, 167
- Transfer Settings
 - Channel, 171
- Transferring
 - License key, 213, 236
 - Project, 213
 - Recipe data record, 323, 329
- Transferring back
 - License key, 213, 236
- Transponder, 32
 - Acceptance, 243
 - Detect, 256
 - Inserting the battery, 81

- Installation, 79
 - Main dimensions, 340
 - Rotary coding switch, 79
 - Setting ID, 81
- Transponder assignment
 - Planning, 63, 64
- Transport damage, 77
- Trend view, 295
 - Buttons, 296
 - Key control, 297
 - Touch operation, 297
- Trends
 - Functional scope, 28
 - Limit violation, 295

U

- UL approval, 43
- Unintentional action, 273, 293
- Updating
 - Operating system, 224
 - With ProSave, 225
 - With WinCC flexible, 225
- Updating the operating system, 213
- Usage
 - In industry, 47
 - In residential areas, 47
- USB
 - Keyboard, 130
 - Mouse, 130
 - Pin assignment, 345
- USB memory stick, 19
- USB-Flashdrive, 19
- Use
 - With additional measures, 55
- User data
 - Backup, 286
 - Changing, 291
 - Restoring, 286
- User group, 285
- User name, 177
- User view, 287
 - Extended, 287
 - Number of characters, 286
 - Simple, 287
- Users, 285
 - Admin, 291, 292
 - Creating, 289
 - Delete, 292
 - Logoff, 289
 - Logon, 288
 - Number of characters, 286

PLC_User, 291, 292

V

Value table

Trend view, 295

VBScript

Functional scope, 28

Vibration alarm

Activate, 159

W

Weight, 347

WinCC flexible ES

Configuration, 209

WinCC flexible Internet settings

E-mail, 177

WinCC flexible option, 232

License key, 235

Windows CE taskbar, 128

Password protection, 128

WINS, 176

Server, 173

Wireless approval, 45

WLAN, 31, 34

Configuring the connection, 147

Interface, 345

Receiver sensitivity, 346

Standards, 345

Transmission power, 346

WLAN quality, 281

WTPFailsafe_IO, 194

WTPfiwlanv2, 194

WTPStandard-IO, 194

Z

ZigBee devices, 71

Zone, 33, 284

Detect, 256

Determining, 257

In the project, 63

Planning, 63

Setting up, 63

Testing, 246

Zone name, 284

