

**ELECTROMAGNETIC EMISSIONS COMPLIANCE REPORT
INTENTIONAL RADIATOR CERTIFICATION TO
FCC PART 15 SUBPART C and Canadian RSS-210 Issue 7 REQUIREMENT**

OF

Full HD Multimedia Player

MODEL No.: LX351HD SATA

BRAND NAME: ZIO

FCC ID: U98-LX351HD

IC ID: 7079A-LX351HD

REPORT NO: E0710034F

ISSUE DATE: November 18, 2007

Prepared for

SDT INFORMATION TECHNOLOGY CO., LTD.

Samil B/D 2F, 5-63, Hyochang-dong, Yongsan-Ku, Seoul, Korea

Prepared by

SHENZHEN EMTEK CO., LTD

Bldg 69, Majialong Industry Zone, Nanshan District,

Shenzhen, Guangdong, China

TEL: 86-755-26954280

FAX: 86-755-26954282

VERIFICATION OF COMPLIANCE

Applicant:	SDT INFORMATION TECHNOLOGY CO., LTD. Samil B/D 2F, 5-63, Hyochang-dong, Yongsan-Ku, Seoul, Korea
Manufacturer:	SDT INFORMATION TECHNOLOGY CO., LTD. 17B7 GuangCaiXinTianDi, GuiMiao Road, NanShan District, ShenZhen, GuangDong, China
Product Description:	Full HD Multimedia Player
Brand Name:	ZIO
Model Number:	LX351HD SATA
Serial Number:	N/A
File Number:	E0710034F
Date of Test:	October 18, 2007 to November 10, 2007

We hereby certify that:

The above equipment was tested by SHENZHEN EMTEK CO., LTD. The test data, data evaluation, test procedures, and equipment configurations shown in this report were made in accordance with the procedures given in ANSI C63.4 (2003) and the energy emitted by the sample EUT tested as described in this report is in compliance with conducted and radiated emission limits of FCC Rules Part 15.247. also, the model complies with Canadian RSS-210 Issue 7 standard.

The test results of this report relate only to the tested sample identified in this report.

Approved By



David Lee / Q.A. Manager
SHENZHEN EMTEK CO., LTD.

Table of Contents

1. GENERAL INFORMATION.....5

1.1 PRODUCT DESCRIPTION..... 5

1.2 RELATED SUBMITTAL(S) / GRANT (S)..... 5

1.3 TEST METHODOLOGY..... 5

1.4 SPECIAL ACCESSORIES 5

1.5 EQUIPMENT MODIFICATIONS 6

1.6 TEST FACILITY 6

2. SYSTEM TEST CONFIGURATION 7

2.1 EUT CONFIGURATION..... 7

2.2 EUT EXERCISE 7

2.3 TEST PROCEDURE 7

2.4 CONFIGURATION OF TESTED SYSTEM 7

3. DESCRIPTION OF TEST MODES 9

4. CONDUCTED EMISSIONS TEST 10

4.1 MEASUREMENT PROCEDURE:..... 10

4.2 TEST SET-UP (BLOCK DIAGRAM OF CONFIGURATION)..... 10

4.3 MEASUREMENT EQUIPMENT USED: 10

4.4 CONDUCTED EMISSION LIMIT..... 11

4.5 MEASUREMENT RESULT:..... 11

4.6 CONDUCTED MEASUREMENT PHOTOS: 12

5. RADIATED EMISSION TEST 13

5.1 MEASUREMENT PROCEDURE..... 13

5.2 TEST SET-UP (BLOCK DIAGRAM OF CONFIGURATION)..... 14

5.3 MEASUREMENT EQUIPMENT USED: 15

5.4 RADIATED EMISSION LIMIT 15

5.5 MEASUREMENT RESULT..... 16

5.6 RADIATED MEASUREMENT PHOTOS: 22

6. OCCUPIED BANDWIDTH TEST..... 23

6.1 MEASUREMENT PROCEDURE..... 23

6.2 TEST SET-UP (BLOCK DIAGRAM OF CONFIGURATION)..... 23

6.3 MEASUREMENT EQUIPMENT USED: 23

6.4 LIMIT 23

6.5 MEASUREMENT RESULTS:..... 23

7. MAXIMUM PEAK OUTPUT POWER TEST 26

7.1 MEASUREMENT PROCEDURE..... 26

7.2 TEST SET-UP (BLOCK DIAGRAM OF CONFIGURATION)..... 26

7.3 MEASUREMENT EQUIPMENT USED: 26

7.4 PEAK POWER OUTPUT LIMIT.....26

7.5 MEASUREMENT RESULTS:.....26

8. BAND EDGE TEST.....27

8.1 MEASUREMENT PROCEDURE.....27

8.2 TEST SET-UP (BLOCK DIAGRAM OF CONFIGURATION).....27

8.3 MEASUREMENT EQUIPMENT USED:27

8.4 MEASUREMENT RESULTS:.....27

9. POWER DENSITY.....29

9.1 TEST EQUIPMENT29

9.2 MEASURING INSTRUMENTS AND SETTING29

9.3 TEST PROCEDURES29

9.4 BLOCK DIAGRAM OF TEST SETUP29

9.5 LIMIT29

9.6. TEST RESULT30

10. ANTENNA APPLICATION.....32

10.1 ANTENNA REQUIREMENT32

10.2. RESULT32

11. RF EXPOSURE EVALUATION33

14.1 FRIIS TRANSMISSION FORMULA: $PD=(POUT * G) / (4 * \pi * R^2)$33

PHOTOGRAPHS OF EUT.....34

1. GENERAL INFORMATION

1.1 Product Description

A major technical descriptions of EUT is described as following:

- A). Standards: IEEE802.11b/g
- B). Operation Frequency: 2400-2483.5MHz
- C). Modulation: OFDM with BPSK, QPSK, 16QAM, 64QAM(11g), BPSK, QPSK, CCK(11b)
- D). Number of Channel: 11
- E). Data Rate: 54Mbps
- F). Transmit Power: 10dBm
- G). Antena GAIN: 5dBi
- H). Antenna Type: External
- I). Power Supply: DC12V/3.5A with Adapter

Channel	Frequency (MHz)	Channel	Frequency (MHz)	Channel	Frequency (MHz)
1	2412	5	2432	9	2452
2	2417	6	2437	10	2457
3	2422	7	2442	11	2462
4	2427	8	2447		

Note:

1. This device is a 2.4GHz Full HD Multimedia Player included 802.11b and 802.11g 2.4GHz transceiver function.
2. Test of channel was included the lowest middle and highest frequency in highest data rate and to perform the test, then record on this report.

1.2 Related Submittal(s) / Grant (s)

This submittal(s) (test report) is intended for FCC ID: U98-LX351HD filing to comply with Section 15.247 of the FCC Part 15, Subpart C Rules. The composite system (receiver) is compliance with Subpart B is authorized under a DoC procedure.

1.3 Test Methodology

Both conducted and radiated testing were performed according to the procedures in ANSI C63.4 (2003). Radiated testing was performed at an antenna to EUT distance 3 meters.

1.4 Special Accessories

Not available for this EUT intended for grant.

1.5 Equipment Modifications

Not available for this EUT intended for grant.

1.6 Test Facility

Site Description

EMC Lab.

: Accredited by CNAS, 2005.11.02

The certificate is valid until 2010.11

The Laboratory has been assessed and proved to be in compliance with CNAS/CL01:2006(identical to ISO/IEC17025: 2005)

The Certificate Registration Number is L2291

Accredited by TUV Rheinland Guangzhou, 2005.1

The certificate is valid until 2008.2

The Laboratory has been assessed according to the requirements ISO/IEC 17025:1999

Accredited by FCC, July 07, 2005

The Certificate Registration Number is 709623.

Accredited by Industry Canada, August 30, 2005

The Certificate Registration Number is 46405-4480

Name of Firm

: SHENZHEN EMTEK CO., LTD

Site Location

: Bldg 69, Majialong Industry Zone,

Nanshan District, Shenzhen, Guangdong, China

2. System Test Configuration

2.1 EUT Configuration

The EUT configuration for testing is installed on RF field strength measurement to meet the Commissions requirement and operating in a manner which intends to maximize its emission characteristics in a continuous normal application.

2.2 EUT Exercise

The Transmitter was operated in the normal operating mode. the Tx frequency was fixed which was for the purpose of the measurements.

2.3 Test Procedure

2.3.1 Conducted Emissions

The EUT is a placed on as turn table which is 0.8 m above ground plane. According to the requirements in Section 13.1.4.1 of ANSI C63.4-2003. Conducted emissions from the EUT measured in the **frequency range between 0.15 MHz and 30MHz** using **CISPR Quasi-Peak and average detector mode**.

2.3.2 Radiated Emissions

The EUT is a placed on as turn table which is 0.8 m above ground plane. The turn table shall rotate 360 degrees to determine the position of maximum emission level. EUT is set 3m away from the receiving antenna which varied from 1m to 4m to find out the highest emission. And also, each emission was to be maximized by changing the polarization of receiving antenna both horizontal and vertical. In order to find out the max. emission, the relative positions of this hand-held transmitter(EUT) was rotated through three orthogonal axes according to the requirements in Section 13.1.4.1 of ANSI C63.4-2003.

2.4 Configuration of Tested System

Fig. 2-1 Configuration of Tested System

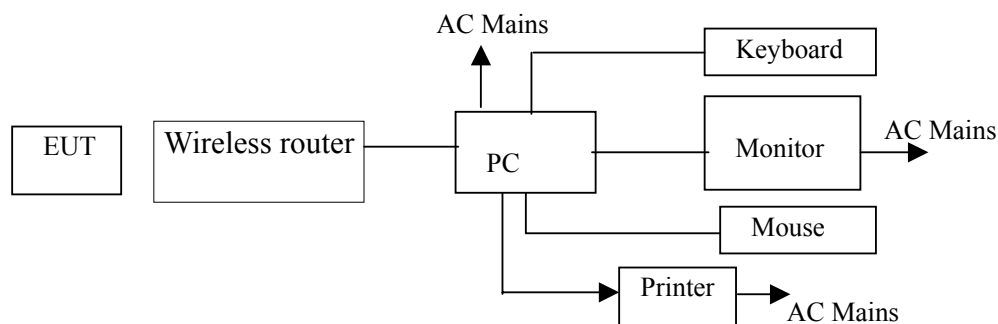

Table 2-1 Equipment Used in Tested System

Item	Equipment	Mfr/Brand	Model/Type No.	FCC ID	Series No.	Note
1.	Full HD Multimedia Player	ZIO	LX351HD SATA	UM4ABD20	N/A	EUT
2.	PC	HEWLETT PACKARD	Vectra VL420 MT	N/A	CN15100363	
3.	CRT Monitor	Sony	SDM-S53	N/A	0413350	
4.	Mouse	HEWLETT PACKARD	M-S48a	N/A	LZE14823966A W	
5.	Printer	HEWLETT PACKARD	C89520	N/A	CN25S182N6	
6	Wireless Router	TP-LINK	TL-WR340G	N/A	06327601461	

Note:

- (1) Unless otherwise denoted as EUT in 『Remark』 column , device(s) used in tested system is a support equipment.

3. Description of test modes

The Transmitter of EUT is a Full HD Multimedia Player and powered by host equipment. This is Digital Transmission system(DTS) and have four type of modulation DBPSK DQPSK CCK&OFDM. The data rates are 54Mbps.

The equipment enables high-speed access without wires to network assets. This adapter uses the IEEE 802.11b/g protocol to enable wireless communications between the host computer and computers, in the same way that the computer would use an Ethernet adapter.

1. For lowest channel : 2412MHz(Channel 1)
2. For middle channel : 2437MHz(Channel 6)
3. For highest channel: 2462MHz(Channel 11)

EUT operating conditions:

The EUT exercise program used during conducted testing was designed to exercise the EUT in a manner similar to typical use, The exercise sequence is listed as below:

1. Setup the EUT and simulators as shown on 2.4.
2. Turn on the power of all equipments.
3. The EUT Ping with the wireless router.
4. Repeat the above steps.

4. Conducted Emissions Test

4.1 Measurement Procedure:

1. The EUT was placed on a table which is 0.8m above ground plane.
2. Maximum procedure was performed on the six highest emissions to ensure EUT compliance.
3. Repeat above procedures until all frequency measured were complete.

4.2 Test SET-UP (Block Diagram of Configuration)

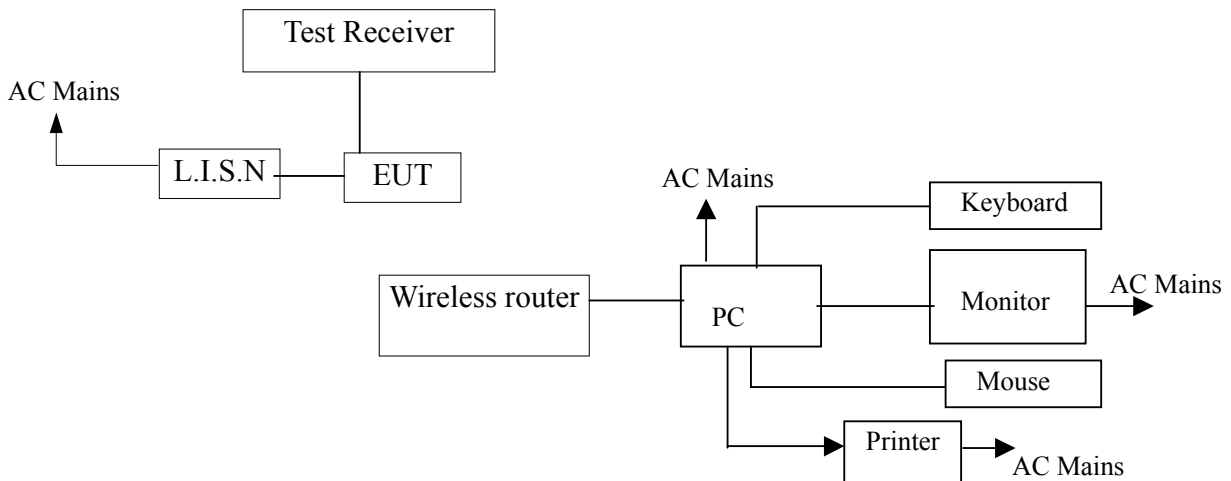

4.3 Measurement Equipment Used:

Conducted Emission Test Site # 4					
EQUIPMENT TYPE	MFR	MODEL NUMBER	SERIAL NUMBER	LAST CAL.	CAL DUE.
Test Receiver	Rohde & Schwarz	ESCS30	828985/018	05/29/2007	05/29/2008
L.I.S.N	Rohde & Schwarz	ESH2-Z5	834549/005	05/29/2007	05/29/2008
L.I.S.N	Rohde & Schwarz	ESH2-Z5	834549/005	05/29/2007	05/29/2008
50ΩCoaxial Switch	Anritsu	MP59B	M20531	005/29/2007	05/29/2008

4.4 Conducted Emission Limit

(7) Conducted Emission

Frequency(MHz)	Quasi-peak	Average
0.15-0.5	66-56	56-46
0.5-5.0	56	46
5.0-30.0	60	50

Note:

1. The lower limit shall apply at the transition frequencies
2. The limit decreases in line with the logarithm of the frequency in the range of 0.15 to 0.50MHz.

4.5 Measurement Result:

Date of Test:	<u>November 19, 2007</u>	Temperature:	<u>22°C</u>
Frequency Detector:	<u>0.15~30MHz</u>	Humidity:	<u>50%</u>
Test Result:	<u>PASS</u>	Test Mode:	<u>802.11b/g</u>

Test Line	Frequency MHz	Emission Level QP dB(μV)	Emission Level AV dB(μV)	Limits QP dB(μV)	Limits AV dB(μV)	Margin QP dB(μV)	Margin AV dB(μV)
Neutral	0.150	50.69	36.85	66.00	56.00	-15.31	-19.15
	0.350	44.10	40.40	58.96	48.96	-14.86	-8.56
	0.370	42.70	40.90	58.50	48.50	-15.80	-7.60
	1.020	46.10	28.20	56.00	46.00	-9.90	-17.80
	2.100	39.50	33.10	56.00	46.00	-16.50	-12.90
	3.580	40.50	36.40	56.00	46.00	-15.50	-9.60
Line	0.150	48.90	35.60	66.00	56.00	-17.10	-20.40
	0.345	43.80	40.50	59.08	49.05	-15.28	-8.55
	0.370	44.50	40.70	58.50	48.50	-14.00	-7.80
	1.250	39.60	32.50	56.00	46.00	-16.40	-13.50
	3.580	42.30	35.80	56.00	46.00	-13.70	-10.20
	3.865	40.50	32.90	56.00	46.00	-15.50	-13.10

4.6 Conducted Measurement Photos:



5. Radiated Emission Test

5.1 Measurement Procedure

- 1 The EUT was placed on a turn table which is 0.8m above ground plane.
2. Maximum procedure was performed on the six highest emissions to ensure EUT compliance.
3. And also, each emission was to be maximized by changing the polarization of receiving antenna both horizontal and vertical.
4. Repeat above procedures until all frequency measured were complete.

5.2 Test SET-UP (Block Diagram of Configuration)

(A) Radiated Emission Test Set-Up, Frequency Below 30MHz

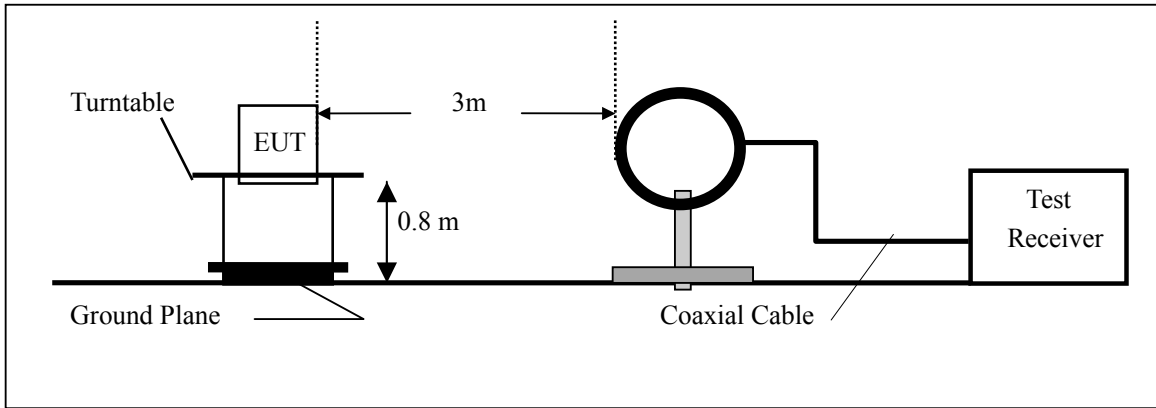

(B) Radiated Emission Test Set-Up, Frequency Below 1000MHz

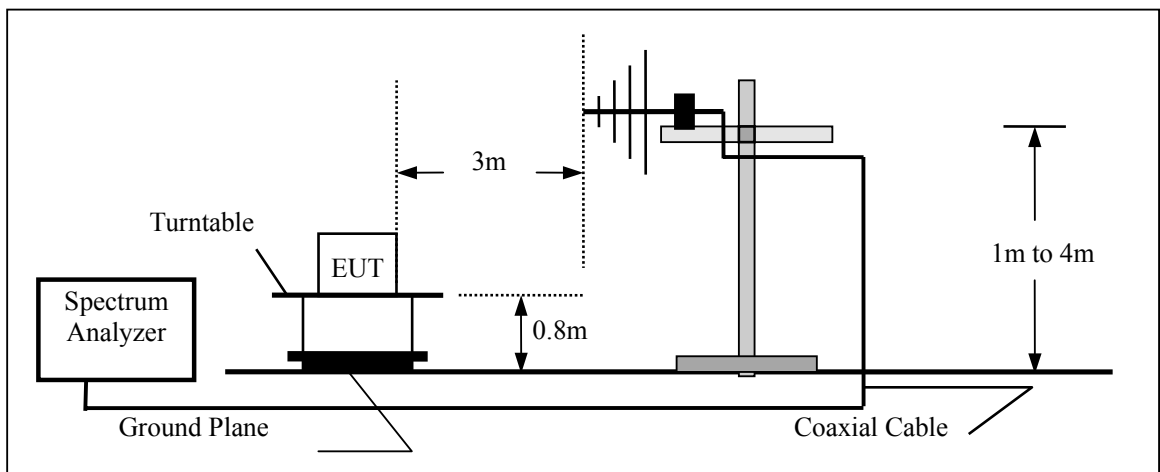

(C) Radiated Emission Test Set-Up, Frequency above 1000MHz

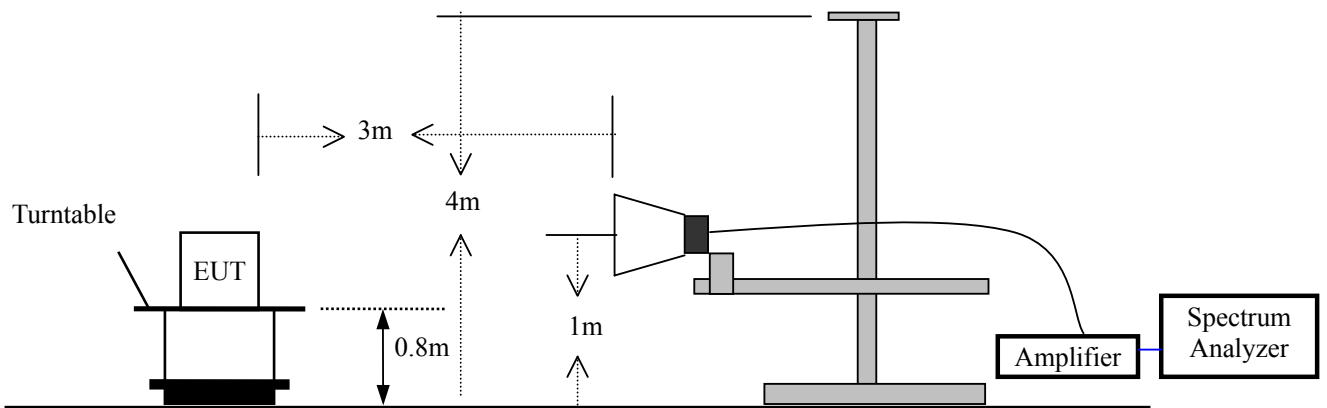

5.3 Measurement Equipment Used:

EQUIPMENT TYPE	MFR	MODEL NUMBER	SERIAL NUMBER	LAST CAL.	CAL DUE.
Spectrum Analyzer	Rohde & Schwarz	FSP7	839511/010	05/29/2007	05/29/2008
Spectrum Analyzer	HP	E4407B	839840481	05/29/2007	05/29/2008
EMI Test Receiver	Rohde & Schwarz	ESCS30	828985/018	05/29/2007	05/29/2008
Pre-Amplifier	HP	8447D	2944A07999	05/29/2007	05/29/2008
Bilog Antenna	Schwarzbeck	VULB9163	142	05/29/2007	05/29/2008
Loop Antenna	ARA	PLA-1030/B	1029	05/29/2007	05/29/2008
Horn Antenna	Electro-Metrics	EM-6961	103314	05/29/2007	05/29/2008
Horn Antenna	Schwarzbeck	BBHA 9120	D143	05/29/2007	05/29/2008

5.4 Radiated emission limit**FCC Class B Limit at 3m**

Frequency MHz	Distance Meter	Field Strength uV/m	Field Strength dBuV/m
30~88	3	100	40.0
88~216	3	150	43.5
216~960	3	200	46.0
Above 960	3	500	54.0

Note: The frequencies above 1000MHz, as measured using instrumentation with a peak detector function was corresponding to 20dB above maximum permitted average limit.

5.5 Measurement Result

Operation Mode: Channel 1 Test Date : November 05, 2007
 Frequency Range: 30~1000MHz Temperature : 28 °C
 Test Result: PASS Humidity : 65 %
 Measured Distance: 3m Test By: Andy

Freq. (MHz)	Ant.Pol. H/V	Emission Level (dBuV)	Limit 3m (dBuV/m)	Margin (dB)	Note
166.500	V	37.31	43.5	-6.19	PK
332.980	V	44.81	46	-1.19	PK
499.470	V	44.76	46	-1.24	PK
832.450	V	43.5	46	-2.50	PK
903.200	V	42.8	46	-3.20	PK
166.480	H	38.92	43.5	-4.58	PK
283.500	H	42.5	46	-3.50	PK
332.480	H	41.8	46	-4.20	PK
674.350	H	43.93	46	-2.07	PK
832.82	H	42.2	46	-3.80	PK

- Note:**
- (1) All Readings are Peak Value.
 - (2) Emission Level= Reading Level+Probe Factor +Cable Loss
 - (3) The average measurement was not performed when the peak measured data under the limit of average detection.

Operation Mode: Channel 6 Test Date : November 05, 2007
 Frequency Range: 30~1000MHz Temperature : 28 °C
 Test Result: PASS Humidity : 65 %
 Measured Distance: 3m Test By: Andy

Freq. (MHz)	Ant.Pol. H/V	Emission Level (dBuV)	Limit 3m (dBuV/m)	Margin (dB)	Note
101.753	V	35.5	43.5	-8.00	PK
166.854	V	37.08	43.5	-6.42	PK
332.975	V	43.51	46	-2.49	PK
500.500	V	44.15	46	-1.85	PK
665.975	V	43.29	46	-2.71	PK
693.512	V	44.26	46	-1.74	PK
936.514	V	42.49	46	-3.51	PK
166.250	H	34.6	43.5	-8.90	PK
332.975	H	44.15	46	-1.85	PK
500.510	H	42.10	46	-3.90	PK
665.51	H	43.15	46	-2.85	PK
832.86	H	44.39	46	-1.61	PK
936.15	H	42.49	46	-3.51	PK

- Note:**
- (1) All Readings are Peak Value and AV.
 - (2) Emission Level= Reading Level+Probe Factor +Cable Loss
 - (3) The average measurement was not performed when the peak measured data under the limit of average detection.

Operation Mode: Channel 11 Test Date : November 05, 2007
 Frequency Range: 30~1000MHz Temperature : 28 °C
 Test Result: PASS Humidity : 65 %
 Measured Distance: 3m Test By: Andy

Freq. (MHz)	Ant.Pol. H/V	Emission Level (dBuV)	Limit 3m (dBuV/m)	Margin (dB)	Note
172.95	V	40.18	43.5	-3.32	PK
337.485	V	42.51	46	-3.49	PK
500.510	V	42.68	46	-3.32	PK
660.570	V	43.15	46	-2.85	PK
832.510	V	41.36	46	-4.64	PK
959.510	V	42.44	46	-3.56	PK
166.480	H	39.73	43.5	-3.77	PK
269.990	H	41.51	46	-4.49	PK
337.485	H	43.96	46	-2.04	PK
500.035	H	42.96	46	-3.04	PK
832.760	H	43.96	46	-2.04	PK

- Note:**
- (1) All Readings are Peak Value and AV.
 - (2) Emission Level= Reading Level+Probe Factor +Cable Loss
 - (3) The average measurement was not performed when the peak measured data under the limit of average detection.

Operation Mode: 802.11b/g(Channel 1) Test Date : November 05, 2007
 Frequency Range: Above 1GHz Temperature : 28 °C
 Test Result: PASS Humidity : 65 %
 Measured Distance: 3m Test By: Andy

Freq. (MHz)	Ant.Pol. H/V	Emission Level(dBuV)		Limit 3m(dBuV/m)		Margin(dB)	
		PK	AV	PK	AV	PK	AV
4824.45	V	58.40	49.85	74.00	54.00	-15.60	-4.15
7236.35	V	52.50	47.57	74.00	54.00	-21.50	-6.43
9648.72	V	51.96	46.81	74.00	54.00	-22.04	-7.19
4824.42	H	53.92	48.62	74.00	54.00	-20.08	-5.38
7236.65	H	51.83	47.32	74.00	54.00	-22.17	-6.68
9647.21	H	48.50	43.96	74.00	54.00	-25.50	-10.04

- Note:**
- (1) All Readings are Peak Value and AV.
 - (2) Emission Level= Reading Level+Probe Factor +Cable Loss
 - (3) The average measurement was not performed when the peak measured data under the limit of average detection.

Operation Mode: 802.11b/g(Channel 6) Test Date : November 05, 2007
 Frequency Range: Above 1GHz Temperature : 28 °C
 Test Result: PASS Humidity : 65 %
 Measured Distance: 3m Test By: Andy

Freq. (MHz)	Ant.Pol. H/V	Emission Level(dBuV)		Limit 3m(dBuV/m)		Margin(dB)	
		PK	AV	PK	AV	PK	AV
4874.35	V	53.51	48.63	74.00	54.00	-20.49	-5.37
7310.24	V	50.91	45.59	74.00	54.00	-23.09	-8.41
9748.82	V	48.61	43.81	74.00	54.00	-25.39	-10.19
4874.24	H	50.19	45.37	74.00	54.00	-23.81	-8.63
7310.52	H	53.51	47.61	74.00	54.00	-20.49	-6.39
9748.45	H	48.61	43.14	74.00	54.00	-25.39	-10.86

- Note:**
- (1) All Readings are Peak Value and AV.
 - (2) Emission Level= Reading Level+Probe Factor +Cable Loss
 - (3) The average measurement was not performed when the peak measured data under the limit of average detection.

Operation Mode: 802.11b/g(Channel 11) Test Date : November 05, 2007
 Frequency Range: Above 1GHz Temperature : 28 °C
 Test Result: PASS Humidity : 65 %
 Measured Distance: 3m Test By: Andy

Freq. (MHz)	Ant.Pol. H/V	Emission Level(dBuV)		Limit 3m(dBuV/m)		Margin(dB)	
		PK	AV	PK	AV	PK	AV
4923.28	V	54.92	48.61	74.00	54.00	-19.08	-5.39
7386.12	V	53.10	46.46	74.00	54.00	-20.90	-7.54
9848.34	V	51.41	45.82	74.00	54.00	-22.59	-8.18
4923.25	H	54.98	47.93	74.00	54.00	-19.02	-6.07
7386.45	H	51.37	44.81	74.00	54.00	-22.63	-9.19
9848.35	H	47.91	42.48	74.00	54.00	-26.09	-11.52

- Note:**
- (1) All Readings are Peak Value and AV.
 - (2) Emission Level= Reading Level+Probe Factor +Cable Loss
 - (3) The average measurement was not performed when the peak measured data under the limit of average detection.

5.6 Radiated Measurement Photos:



6. Occupied Bandwidth test

6.1 Measurement Procedure

The EUT was operating in IEEE 802.11b/g mode or could be controlled its channel. Printed out the test result from the spectrum by hard copy function.

6.2 Test SET-UP (Block Diagram of Configuration)

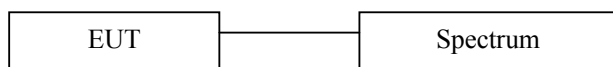

6.3 Measurement Equipment Used:

Same as 4.3 Radiated Emission Measurement.

6.4 Limit

The minimum 6dB bandwidth shall be at least 500kHz.

6.5 Measurement Results:

Refer to attached data chart.

Spectrum Detector:	PK	Test Date :	November 15, 2007
Test By:	Andy	Temperature :	28 °C
Test Result:	PASS	Humidity :	65 %

Channel number	Channel frequency (MHz)	Measurement level (MHz)	Required Limit (KHz)
1	2412	12.25	>500
6	2437	10.25	>500
11	2462	10.13	>500

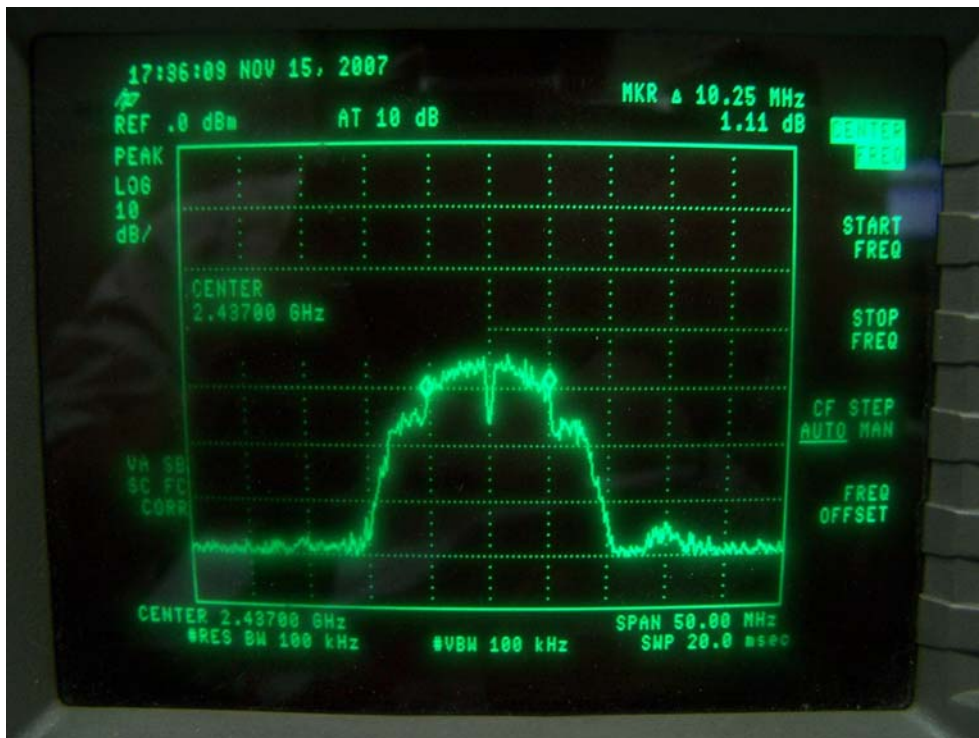

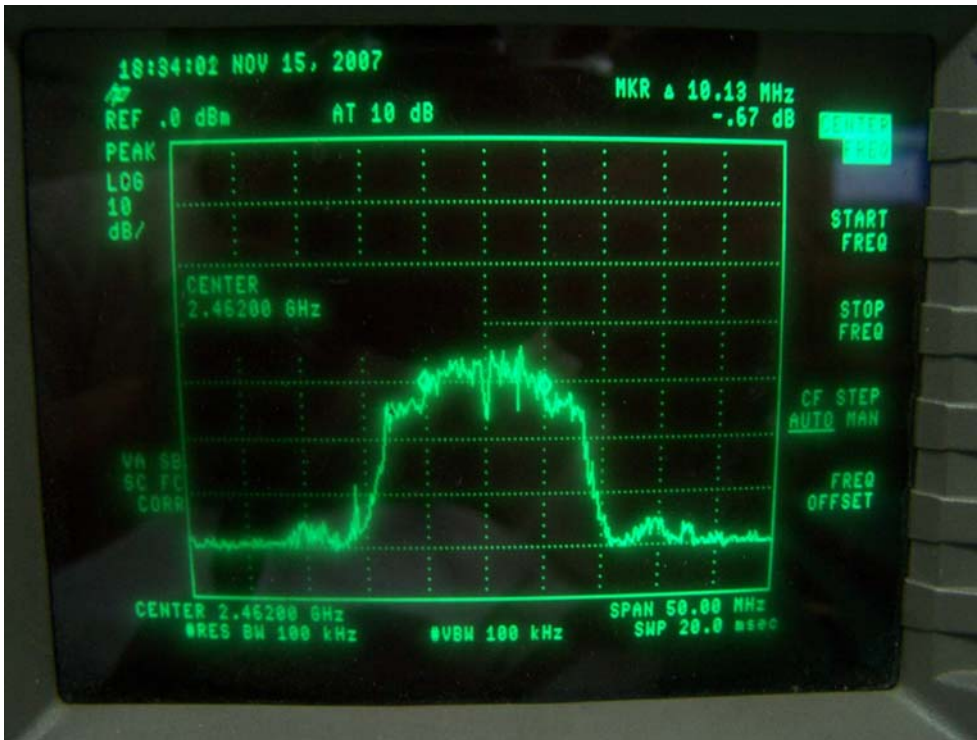

7. MAXIMUM PEAK OUTPUT POWER TEST

7.1 Measurement Procedure

- a. The Transmitter output (antenna port) was connected to the power meter.
- b. Turn on the EUT and power meter and then record the peak power value.
- c. Repeat above procedures on all channels needed to be tested.

7.2 Test SET-UP (Block Diagram of Configuration)

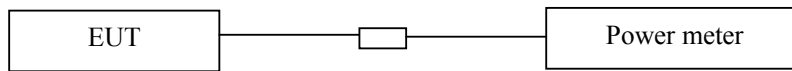

7.3 Measurement Equipment Used:

EQUIPMENT TYPE	MFR	MODEL NUMBER	SERIAL NUMBER	LAST CAL.	CAL DUE.
Power meter	Boonton	4232A	29001	05/29/2007	05/29/2008
Power sensor	Boonton	51011-EMC	31184	05/29/2007	05/29/2008

7.4 Peak Power output limit

The maximum peak power shall be less 1Watt.

7.5 Measurement Results:

Refer to attached data chart.

Spectrum Detector:	PK	Test Date :	November 05, 2007
Test By:	Andy	Temperature :	28 °C
Test Result:	PASS	Humidity :	65 %

Channel number	Channel Frequency (MHz)	Peak Power output(dBm)	Peak Power Limit(W)	Pass/Fail
1	2412.00	9.15	1W(30dBm)	PASS
6	2437.00	9.61	1W(30dBm)	PASS
11	2462.00	8.94	1W(30dBm)	PASS

8. Band EDGE test

8.1 Measurement Procedure

1. The EUT was Operating in hopping mode or could be controlled its channel. Printed out test result from the spectrum by hard copy function.
2. The EUT was placed on a turn table which is 0.8m above ground plane.
3. Maximum procedure was performed on the six highest emissions to ensure EUT compliance.
4. And also, each emission was to be maximized by changing the polarization of receiving antenna both horizontal and vertical.
5. Repeat above procedures until all frequency measured were complete.

8.2 Test SET-UP (Block Diagram of Configuration)

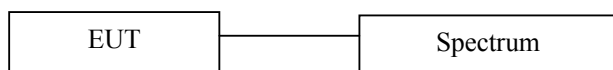

8.3 Measurement Equipment Used:

Same as 4.3 Radiated Emission Measurement.

8.4 Measurement Results:

Refer to attached data chart.

Spectrum Detector:	PK	Test Date :	November 04, 2007
Test By:	Andy	Temperature :	28 °C
Test Result:	PASS	Humidity :	65 %

1. Conducted Test

Frequency (MHz)	Peak Power Output(dBm)	Emission read Value(dBm)	Result of Band edge(dBc)	Band edge Limit(dBc)
<2400	-38.47	-67.65	29.18	>20dBc
>2483.5	-34.77	-69.45	34.68	>20dBc

2. Radiated emission test

Frequency (MHz)	Antenna polarization (H/V)	Emission (dBuV/m)		Band edge Limit (dBuV/m)	
		QP	AV	QP	AV
<2400	V	47.65	42.60	74.00	54.00
>2483.5	V	48.10	42.32	74.00	54.00

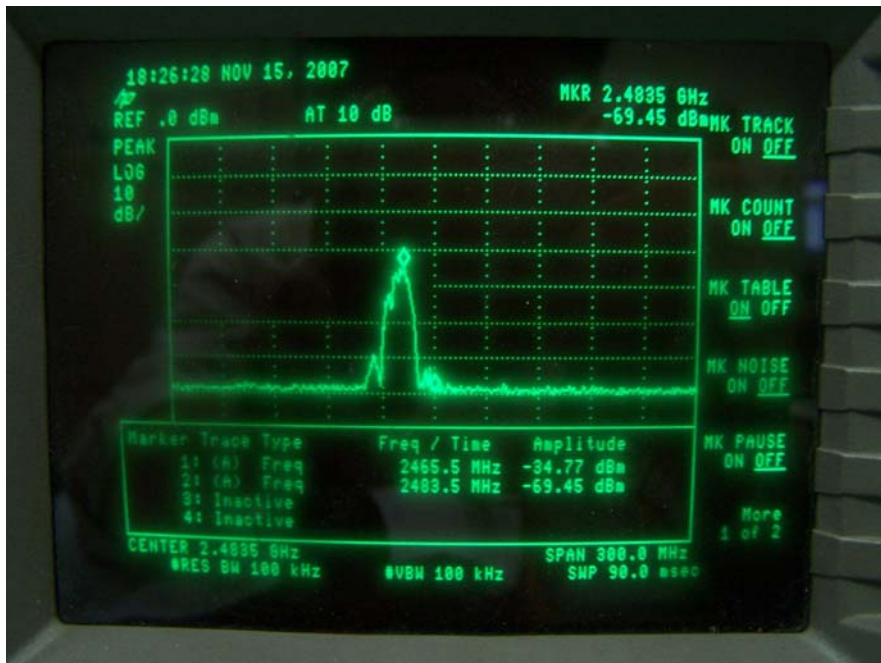
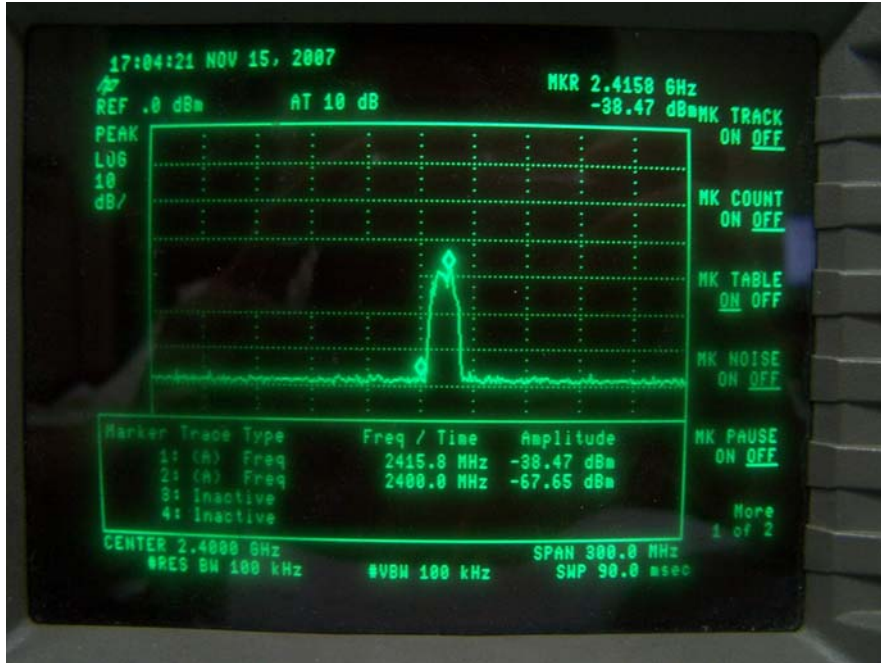

9. Power density

9.1 Test Equipment

EQUIPMENT TYPE	MFR	MODEL NUMBER	SERIAL NUMBER	LAST CAL.	CAL DUE.
Spectrum Analyzer	HP	8594E	88156318	05/29/2007	05/29/2008

9.2 Measuring Instruments and setting

The following table is the setting of spectrum analyzer.

Spectrum analyzer	Setting
Attenuation	Auto
Span Frequency	300kHz
RB	3kHz
VB	30kHz
Detector	Peak
Trace	Max hold
Sweep Time	100s

9.3 Test Procedures

- The transmitter output (antenna port) was connected to the spectrum analyzer.
- Set RBW of spectrum analyzer to 3kHz and VBW to 30kHz, Set Detector to Peak, Trace to Max Hold.
- Mark the frequency with maximum peak power as the center of the display of the spectrum.
- Set the span to 300kHz and the sweep time to 100s and record the maximum peak value.

9.4 Block Diagram of Test setup

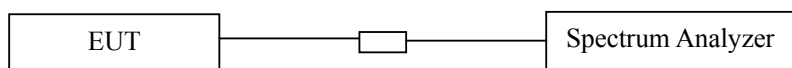

9.5 Limit

The transmitted power density averaged over any 1 second interval shall not be greater +8dBm in any 3KHz bandwidth.

9.6. Test Result

Spectrum Detector: PK Test Date : November 04, 2007
 Test By: Andy Temperature : 28 °C
 Test Result: PASS Humidity : 65 %

Frequency (MHz)	Measurement Level (dBm)	Required limit (dBm)	Result
2412.00	-50.72	<8dBm	PASS
2437.00	-43.90	<8dBm	PASS
2462.00	-44.15	<8dBm	PASS

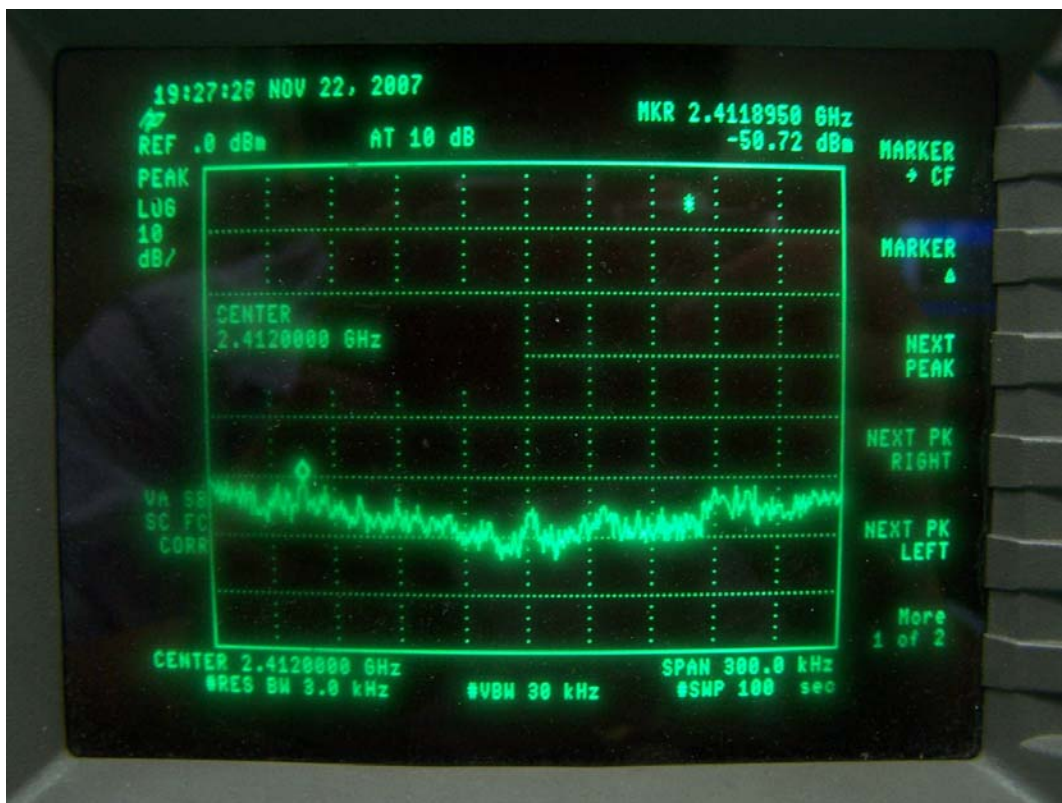

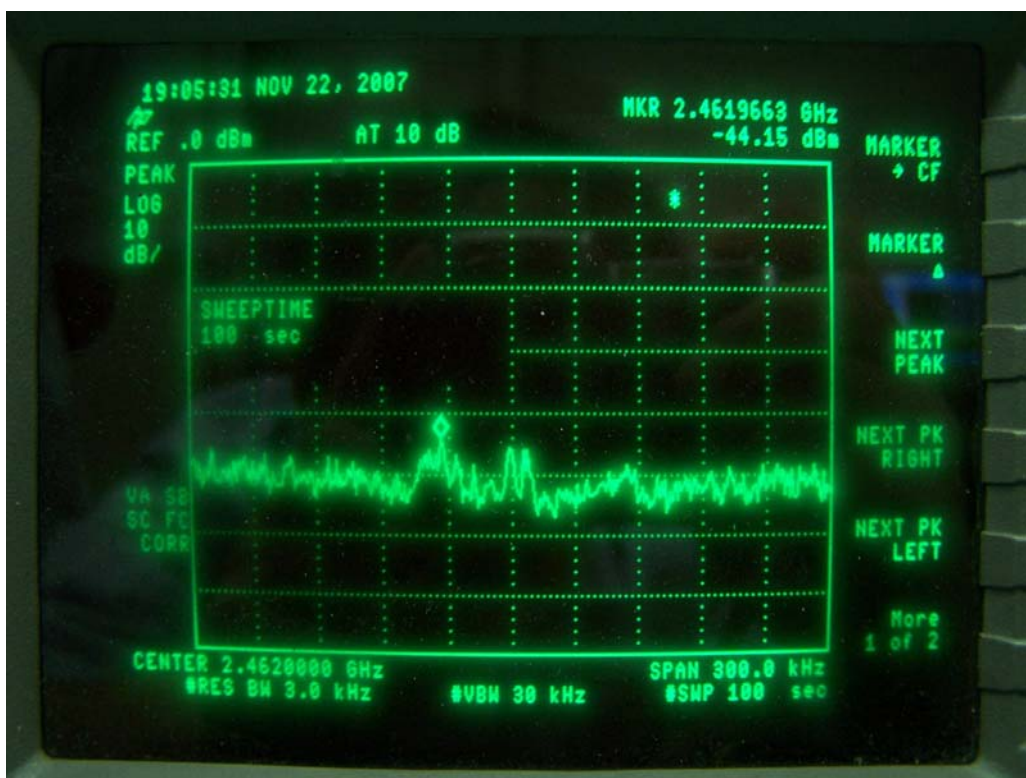
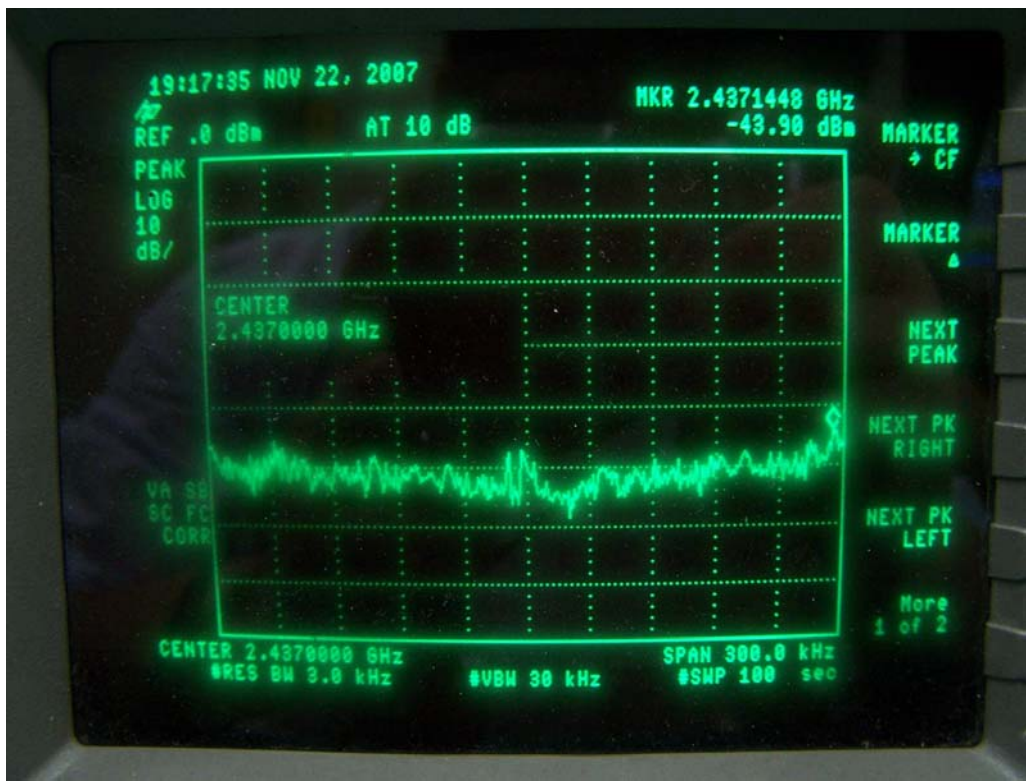

10. Antenna Application

10.1 Antenna requirement

The EUT'S antenna is met the requirement of FCC part 15C section 15.203 and 15.240.

FCC part 15C section 15.247 requirements:

Systems operating in the 2412-2462MHz band that are used exclusively for fixed, point-to-point operations may employ transmitting antennas with directional gain greater than 6dBi provided the maximum peak output power of the intentional radiator is reduced by 1dB for every 3dB that the directional gain of the antenna exceeds 6dBi.

10.2. Result

The EUT's antenna used a chip antenna and integrated on PCB, The antenna's gain is 5dBi and meets the requirement.

11. RF EXPOSURE EVALUATION

According to FCC 1.1310: The criteria listed in the following table shall be used to evaluate the environment impact of human exposure to radio frequency(RF) Radiation as specified in § 1.1307(b)

Limits for Maximum Permissible Exposure(MPE)

Frequency Range(MHz)	Electric Field Strength(V/m)	Magnetic Field Strength(A/m)	Power Density(mW/cm ²)	Average Time
(A) Limits for Occupational/Control Exposures				
300-1500	--	--	F/300	6
1500-100000	--	--	5	6
(B) Limits for General Population/Uncontrol Exposures				
300-1500	--	--	F/1500	6
1500-100000	--	--	1	30

14.1 Friis transmission formula: $P_d = (P_{out} * G) / (4 * \pi * R^2)$

Where

P_d = Power density in mW/cm²

P_{out} =output power to antenna in Mw

G= gain of antenna in linear scale

π =3.1416

R= distance between observation point and center of the radiator in cm

P_d the limit of MPE, 1mW/cm². If we know the maximum gain of the antenna and total power input to the antenna, through the calculation, we will know the distance where the MPE limit is reached.

14.2 Measurement Result

Antenna gain: 2 dBi

Channel	Channel Frequency (MHz)	Output Peak power (mW)	Antenna Gain (dBi)	Power density at 25cm (mW/ cm ²)	Power density Limits (mW/cm ²)
1	2412.00	9.15	5	0.0058	1
6	2437.00	9.61	5	0.0062	1
11	2462.00	8.94	5	0.0057	1

APPENDIX 1

PHOTOGRAPHS OF EUT

UP View of TX



Bottom View of TX



Internal of TX- Open

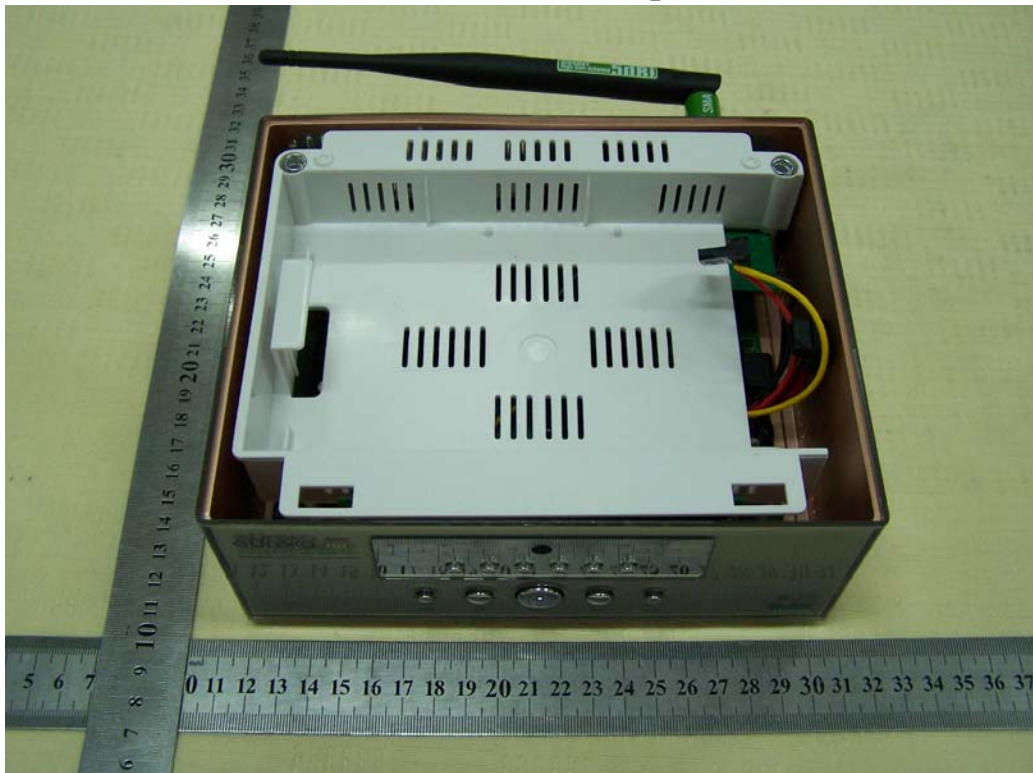

Internal of TX- 1

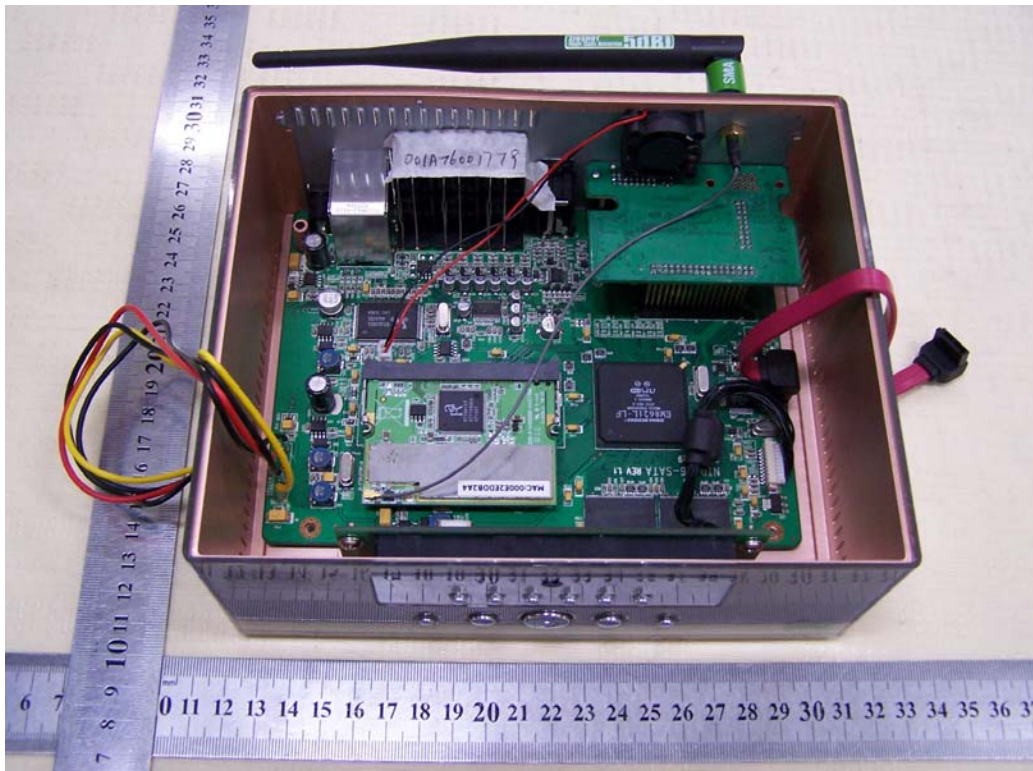

Internal of TX- 2

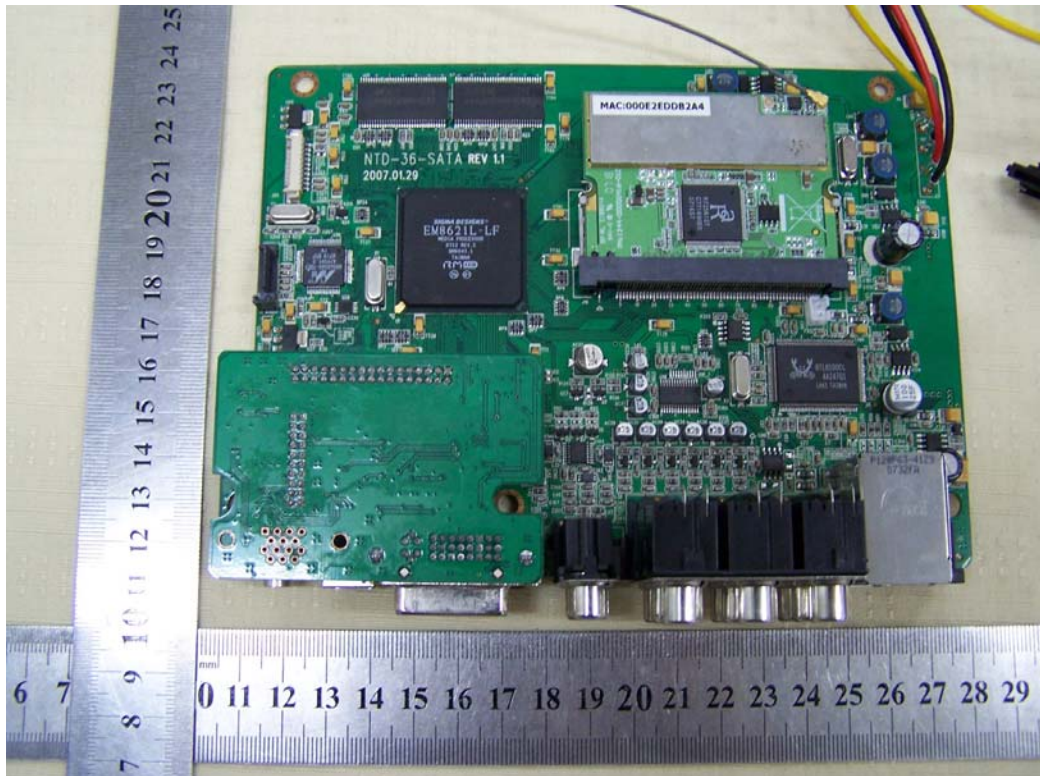

Internal of TX- 2

