

Table of contents	Page
Safety information	25
Box contents	26
Quick overview	27
Headphones	27
Neckloop	27
Transmitter	27
Accessories	27
Connect transmitter to a sound source	28
RCA phono socket(s)	29
SCART socket	29
Headphones socket	30
Microphone	30
Digital TOSlink socket	31
mains power supply	31
Use Swing digital	32
Use SWING digital headphone version	32
Use SWING digital LR neckloop version	32
Safety lock in the neckloop	33
Listening with the 3.5 mm stereo output	33
Pairing of transmitter and receiver	34
Set balance	35
Adjust audio	35
Set volume	36
Transparent cover	36
Charge battery	37
Cleaning and care	38
Clean transmitter and receiver	38
Cleaning of silicone ear adapters	38
Exchange of the silicone ear adapters	38
Important information	39
Warranty	39
Environmental information/disposal	40
Battery	40
Troubleshooting	41
Technical Data	43

Safety information

- Before you start operating this device, read these instructions carefully and completely.
- Please retain these operating instructions so that they are accessible at any time also for other users.
- The device and especially the power supply are designed exclusively for operation in dry interior spaces. A flawless function is guaranteed for a room temperature of 10 °C to 35 °C.
- Please handle the device and the accessories carefully and install them only in low-dust and clean locations.
- Clean the transmitter and the receiver regularly. For hygienic reasons, the soft silicone ear adapters should be cleaned regularly. Replacement soft silicone ear adapters are available as accessories.
- Place the transmitter with care, the rubber feet may cause damage to polished furniture.
- Only use the supplied power supply.
- We recommend to unplug the power supply from the electrical outlet if you are absent for several days.

Caution:

High volume can be set on your receiver. Please adhere to the following information to protect your ears or the ears of persons with normal hearing, especially children, from hearing impairments due to a high volume.

1. Please set a low volume level before you put the receiver on.
2. During use, adjust the volume to a level agreeable to you.
3. The neckloop receiver may cause interference with heart pacemakers. Please contact your physician or manufacturer of the pacemaker to ensure the pacemaker is not subject to possible interference.
4. If you use other medical devices, please use the SWING only by adhering to the safety information/safety directives of your physician or the manufacturer.

Safety information for the lithium polymer battery

The battery used in SWING is a lithium polymer battery, which was produced in accordance with the most current provisions and safety regulations. The battery can be damaged when misused or if not used according to the specifications, in this case Humantechnik accepts no liability.

Warning!

The following risks exist in extreme cases:



- Heat development
- Fire development
- Explosion
- Smoke and gas development

- Do not heat the battery above 70°C, e.g., through sun radiation or by casting it into fire.
- Do not subject the battery to moisture.
- Do not short circuit the battery
- Do not disassemble or deform the battery.
- Store device/battery in cool and dry places at room temperature.
- Use only the provided charger for the battery.
- Recharge the battery in the device regularly in case the device is not used for a longer time (every 6 months for app. 1 hour).
- Charge the battery only at ambient temperatures of 10°C to 40°C.
- Do not recharge the battery if the device is clearly damaged.
- Please return defective devices or devices with worn out batteries to your retailer.

Box contents

The SWING digital / SWING digital LR system includes:

- 1 SWING digital receiver
- 1 SWING digital transmitter
- 1 battery AP12A
- 1 screwdriver
- 1 power supply
- 1 audio connection cable with 3.5 mm stereo stereo jack
- 1 audio adapter 3.5 mm on 6.3 mm stereo stereo jack
- 1 audio adapter 3.5mm - RCA Phono
- 1 Toslink cable
- 1 pair of additional small silicone ear adapters (Headphone version)

Optional extras
SCART adapter
Microphone

Quick overview

These operating instructions let you fold the first 2 pages out. These pages show images of the SWING with identification by numbers.

Headphones:

- 1 volume control
- 2 speaker ear adapters
- 3 battery compartment
- 4 status LED
- 5 pairing button (connect)
- 6 balance (Bal)
- 7 tone adjustment left right (tone)

Neckloop:

- 8 On/Off switch (On / Off)
- 9 volume control
- 10 induction loop
- 11 safety break
- 12 battery compartment
- 13 status LED
- 14 pairing button (connect)
- 15 balance (Bal)
- 16 tone adjustment left right (tone)

Transmitter:

- 17 charging bay
- 18 charge LED for receiver in charging bay
- 19 replacement battery charging bay
- 20 charge LED for additional battery charging bay
- 21 status LED transmitting

Accessories:

- 22 power supply connection
- 23 optical input digital
- 24 AUDIO, MIC / optical selector switch
- 25 female connector for connection to a sound source (green)
- 26 female connector for connection to a microphone (black)
- 27 pairing button (connect)

We congratulate you for purchasing your »SWING« headphones. You have chosen a reliable state-of-the-art device. Please review these operating instructions carefully to ensure that you commission the device correctly and that you are familiar with all functions of the device.

Connect transmitter to a sound source

Please switch the sound source off before connecting the transmitter.

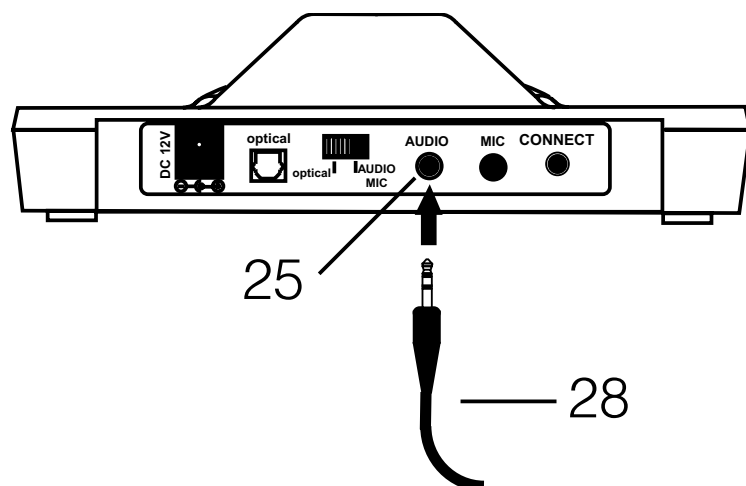

Plug the provided audio connection cable **28** into the green “Audio” female connector **25** of the transmitter.

Several options exist to connect the SWING digital to a sound source (e.g. TV, etc.).

Please check the connection options of your sound source.



– RCA phono female connector

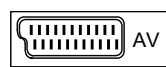

– SCART female connector



– Headphones connection



– External microphone (optional)

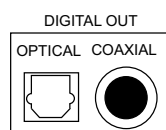

– S/PDIF output

Connect transmitter to a RCA phono female connector

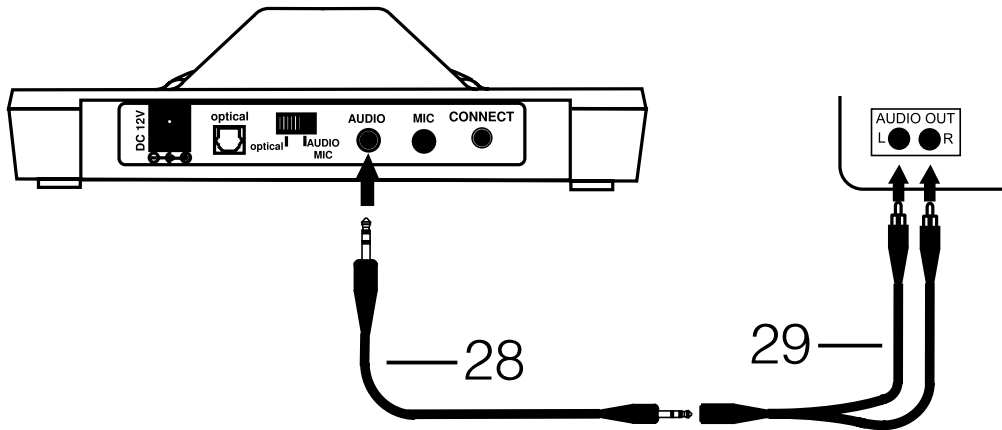

Connect the adapter cable with the RCA phono plugs **29** to the audio connection cable **28**.

Plug the RCA phono plug into the RCA phono connection of your sound source. Please ensure that the white connection is connected to the white connection of your sound source.

Please ensure that the red connection is connected to the red connection of your sound source.

Optionally, a S/PDIF digital audio adapter is available for connection to digital audio sources.

Connect transmitter to a SCART connector (optional)

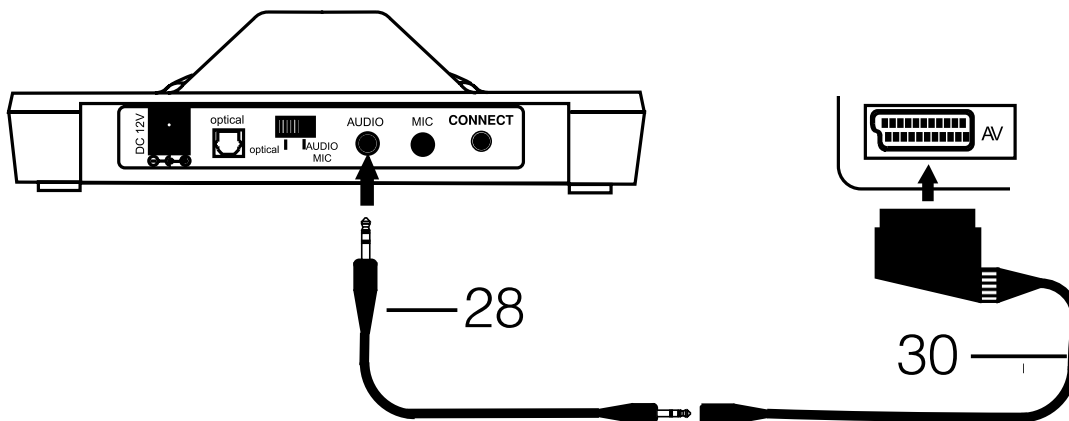

The SCART adapter is not included in the contents. It can be purchased from your retailer.

Plug the SCART adapter **30** into the audio connection cable **28**.

Plug the SCART adapter into the SCART socket of your source of sound.

Connect transmitter headphone connector

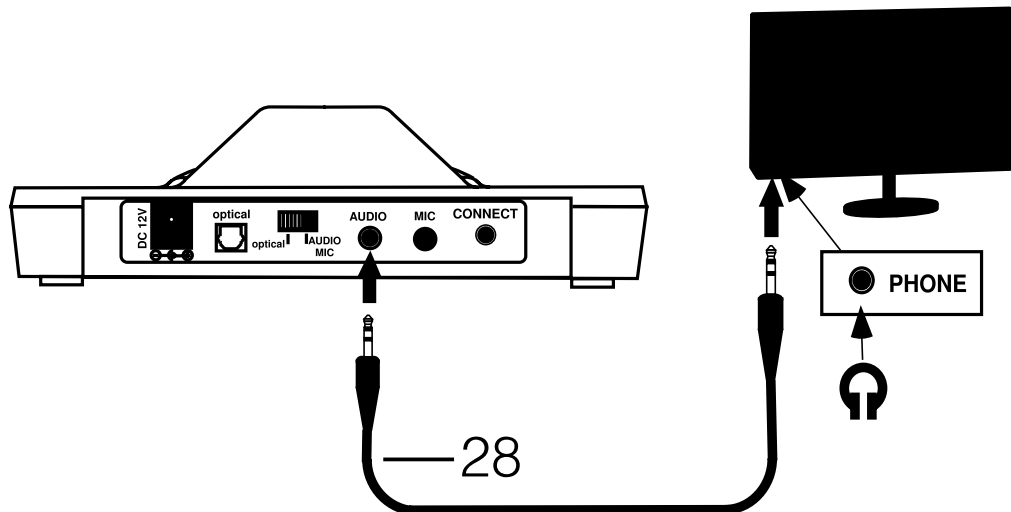

Plug the audio connection cable **28** into the headphone connection of your sound source.

You may need the 6.3 mm headphone plug adapter for the connection of the headphones to your sound source. Set the volume of your sound source to an average volume.

Connect the transmitter to the microphone (optional)

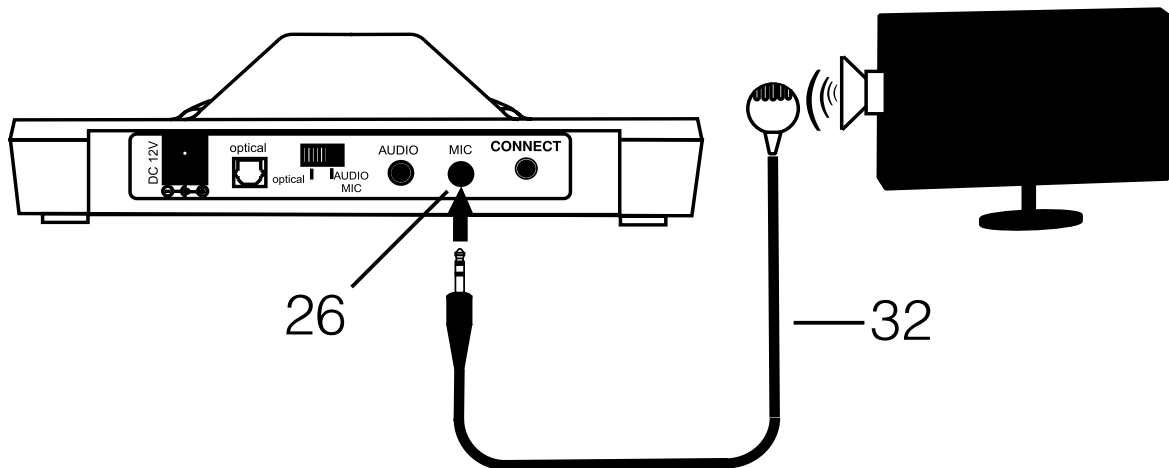

The microphone is not included in the contents. It can be purchased from your retailer.

Plug the microphone **32** into the black “MIC” connection **26** of the transmitter. Fasten the microphone to the loudspeaker of your sound source.

Connect transmitter to the digital Toslink connector

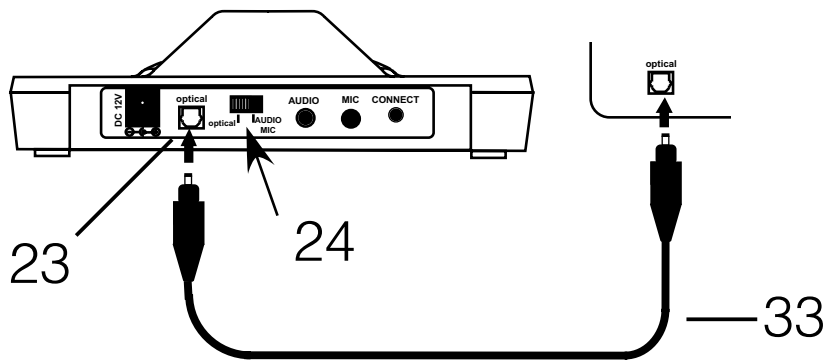

Remove protective ends from TOSlink cable. Connect the optical Toslink cable **33** to the “optical” connection **24** of the transmitter and connect it with your source of sound. The switch **25** must be set to “optical”.
NOTE: Your TV digital output must be set to PCM audio.
This would be found in the Audio setup of the TV menu system.

Connect transmitter to the mains supply

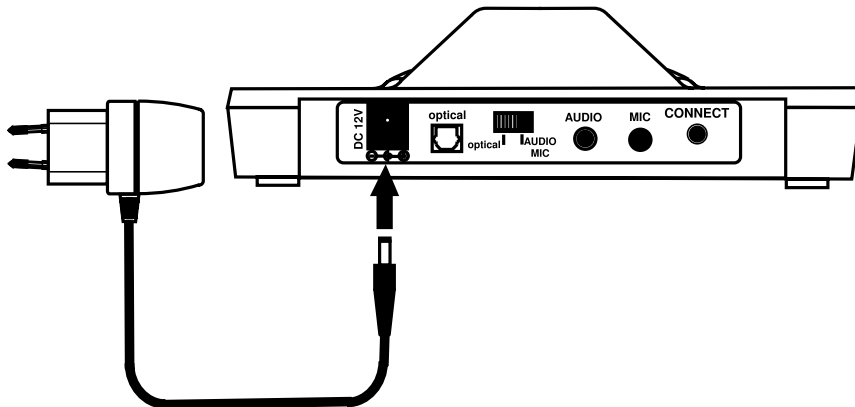

Connect the provided power supply to the transmitter using the power supply connection “DC12V”. The power supply needs to be connected to an electrical outlet.

Please charge the receiver with the battery installed in the receiver for 6 hours before commissioning the device for the first time.

Operating Swing digital

SWING digital headphone version

Please follow the instructions to use your SWING digital:

1. Switch your sound source on (e.g. TV).
2. Adjust the volume level controller **1** initially to a low volume to protect your ears. The volume increases when you turn the dial in the direction of “5” and it decreases when you turn the dial in the direction of “0”.
3. Please put the headphones on. By opening the speaker arms, the headphones switch on automatically. The LED **4** always indicates that the receiver is switched on.
4. The blue LED bar **21** is illuminated only when sound is being transmitted by the transmitter.
5. Set the desired volume **1**.
6. If you remove the headphones they will switch off automatically. We recommend the headphones are returned to the transmitter charging cradle when not in use so they will be charged for the next time.

SWING digital LR neckloop version

Please follow the instructions to use your SWING digital LR:

1. Switch your sound source on (e.g. TV).
2. Adjust the volume level controller **9** initially to a low volume to protect your ears. The volume increases when you turn the dial in the direction of “5” and it decreases when you turn the dial in the direction of “0”.
3. Ensure that the safety break has been closed completely. The neck loop safety break is designed to minimize accidents.
4. The receiver is switched on and off by using the ON/OFF switch on the back. Caution: Always switch the receiver off after use because the battery discharges itself otherwise. The LED **13** always indicates that the receiver is switched on.
5. The blue LED bar **21** is illuminated only when sound is being transmitted by the transmitter.
6. Set the desired volume **1**.
7. Switch the receiver off after use. We recommend the neckloop receiver is returned to the transmitter charging cradle when not in use so it will be charged for the next time.

Safety break in the neckloop

(LR neckloop version only)

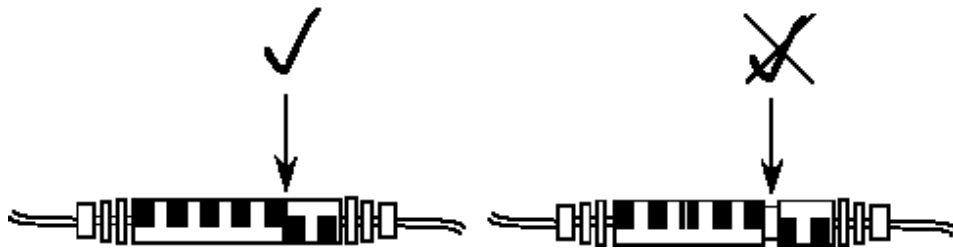

Please ensure that the safety break is completely closed in the neckloop to guarantee best performance.

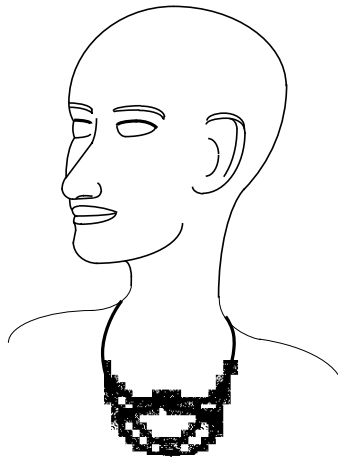

Please ensure the receiver is worn correctly.

Using the the 3.5 mm stereo output

(LR neckloop version only)

The following accessories can be connected to the 3.5 mm stereo jack socket:

- Earphones
- Over head or under chin headphones
- Ear hooks, ear loops - mono or binaural
- Direct hearing aid connections - mono or binaural

Important!

The battery life of the receiver can be reduced significantly depending on the accessories connected to the stereo output. We recommend purchasing an additional battery to guarantee a longer operating time.

Pairing of transmitter and receiver

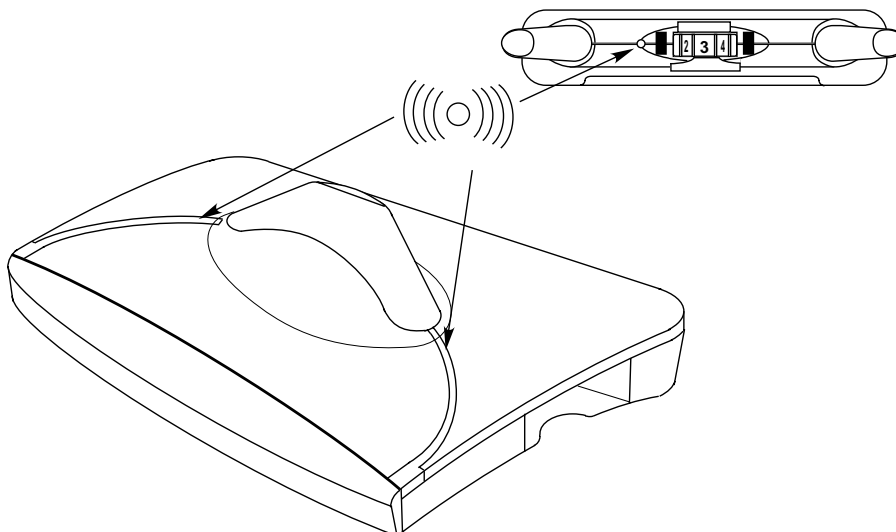

If you want to add an additional receiver to the transmitter then the new receiver must first be paired with the transmitter. This is required to ensure that transmitter and receiver recognize each other and that they can transmit the encrypted data.

This is only required once for each set of headphones. A maximum of 4 sets of headphones can be paired with one transmitter.

If the headphones do not find a transmitter, then the red LED **4** blinks and no signal will be received.

Please follow these instructions to pair the receiver with the transmitter:

1. Ensure that the transmitter is connected to an electrical outlet and that it is provided with electricity.
2. Wear the receiver to ensure that it is switched on. For the SWING digital LR version switch the LR receiver on.
3. Press the “Connect” button **27** briefly at the transmitter. The blue LED bar starts flashing.
4. Press the “Connect” button **5 / 14** briefly at the receiver to complete the pairing.
5. Once the pairing has been completed, the transmitter will stop flashing.

Balance control

(SWING digital Headphones and SWING IR LR 3.5 mm socket output only)

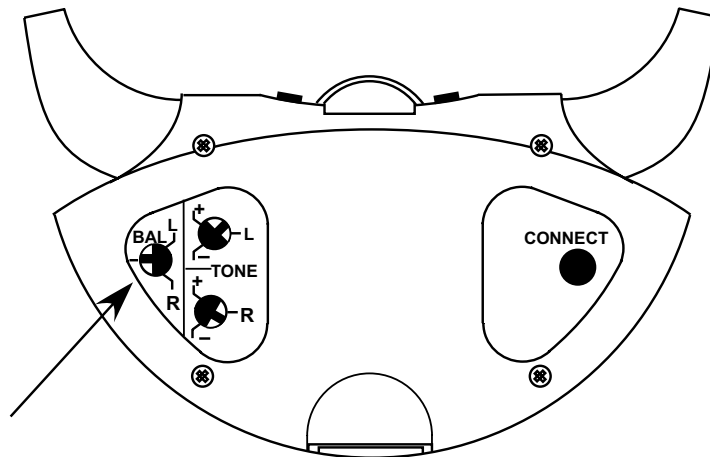

The balance controls the volume distribution between the right and the left ears. Adjust the balance in such a way that you hear equally in both ears. This function does not affect the output of the integrated neckloop with the IR LR receiver. Leave balance control at mid point when using the integrated neckloop.

Tone control adjustment

(SWING digital and SWING digital LR)

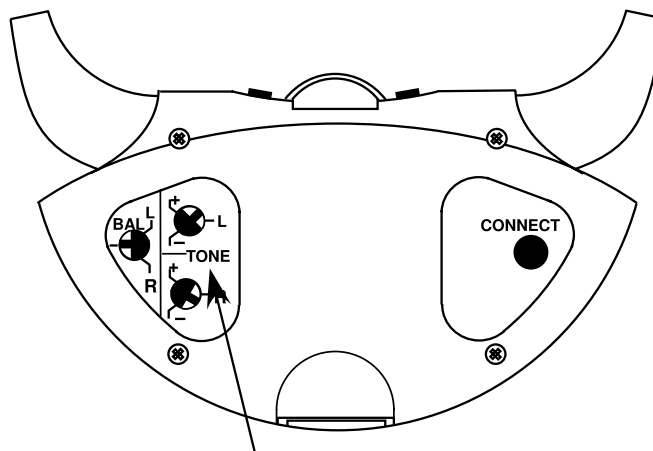

The tone control is used to change the clarity of the sound output. This can be done independently for each ear with left and right controls.

Note: When listening through the neckloop of the LR receiver, only the right (R) control has an effect. The left (L) control has no effect.

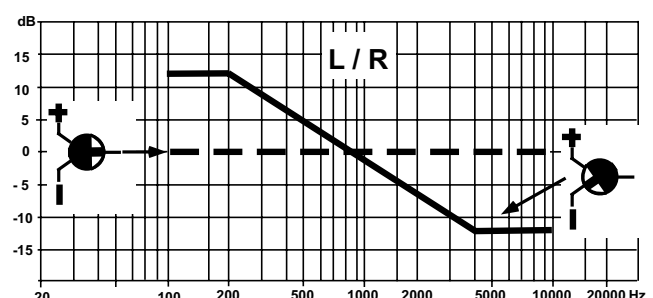
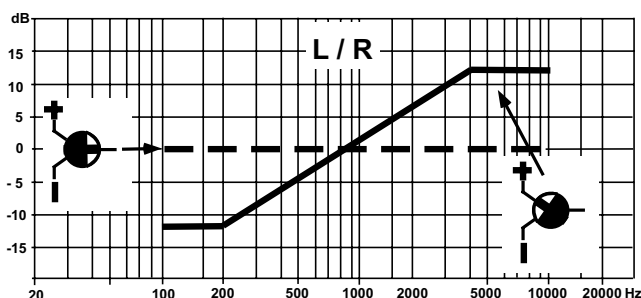

Volume Control

Set the volume to a level comfortable for you by adjusting the volume control.

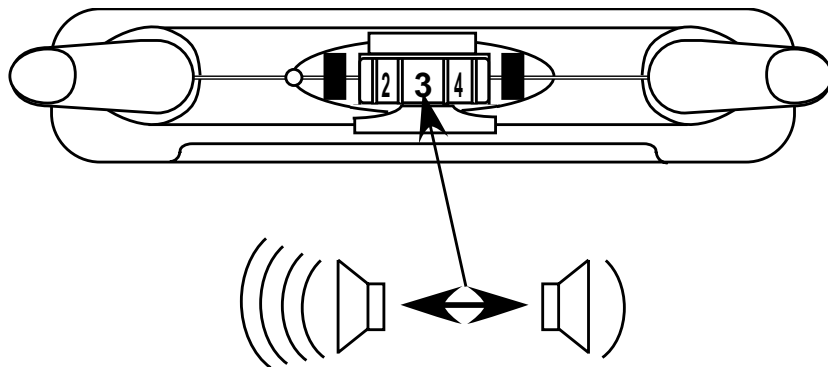

Transparent cover

The transparent cover protects the volume control against unintended adjustment of the volume control and against contamination by dust or fluids.

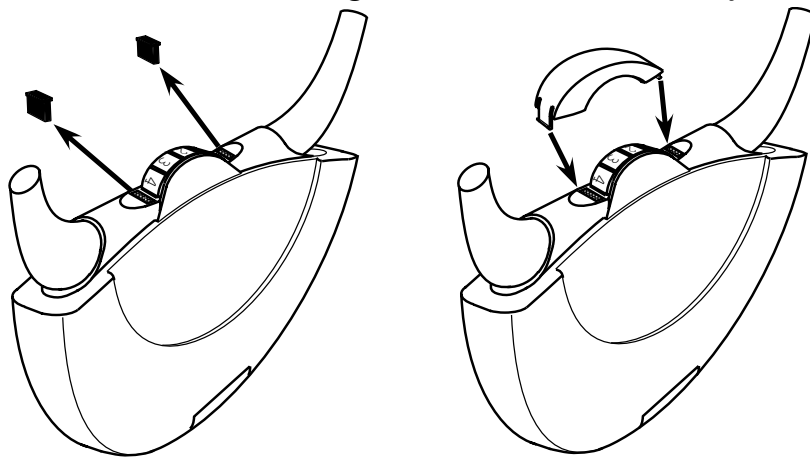

Remove both rubber covers and click the transparent cover into the openings.

Range

SWING digital uses the latest 2.4Ghz technology. In optimal cases the range is up to 45 m.

The range depends strongly on the building and the environment. The 2.4Ghz radio technology also works through walls.

Battery charging

A fully charged battery can be used for up to 6 hours listening. The LED **4/13** starts flashing red when the battery is almost empty. The battery should now be charged or swapped for a fully charged battery. The listening time is dependent on the volume control setting and the type of sound you are listening to, e.g. speech or music.

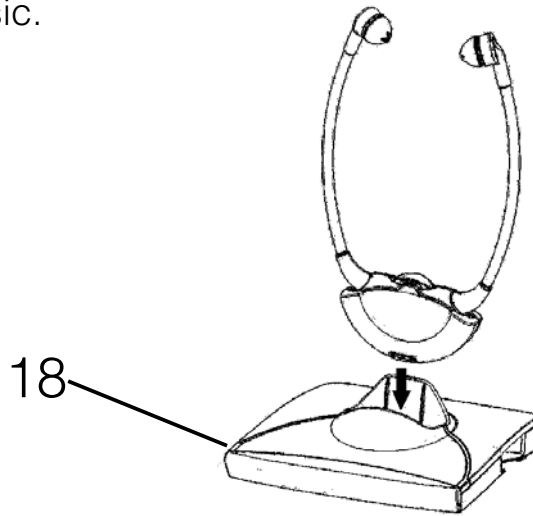

After use, place the receiver onto the charging cradle of the receiver without applying pressure. When the receiver is placed correctly the LED **18** will light. When LED **18** is illuminated RED, the receiver is charging. When the LED **18** is illuminated Green, the receiver battery is fully charged.

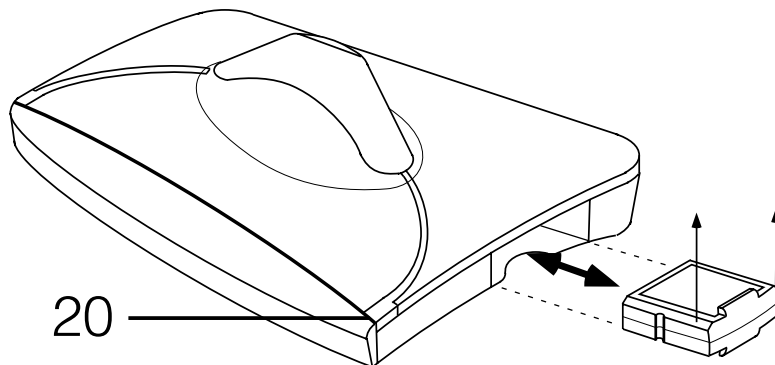

An additional battery may be charged in the transmitter. Additional batteries are available from your retailer.

The additional battery can be plugged in into the side charging bay **19**. Please ensure that the chamfered edges point upward. The battery requires very little force to be inserted. When LED **20** is illuminated RED, the battery is charging. When the LED **20** is illuminated Green, the battery is fully charged. If you have an additional battery we recommend swapping the batteries between the charging bay and the receiver at least once a week. This helps to use the batteries in a balanced manner to obtain the maximum life from them.

All batteries lose their capacity over time. This is characterized by a shorter usage time.

Cleaning and care

Transmitter and receiver

If the devices are dusty or dirty, please clean them with a soft, clean and slightly moist cloth.

Please disconnect the transmitter from the mains supply before you start cleaning.

Silicone ear adapters

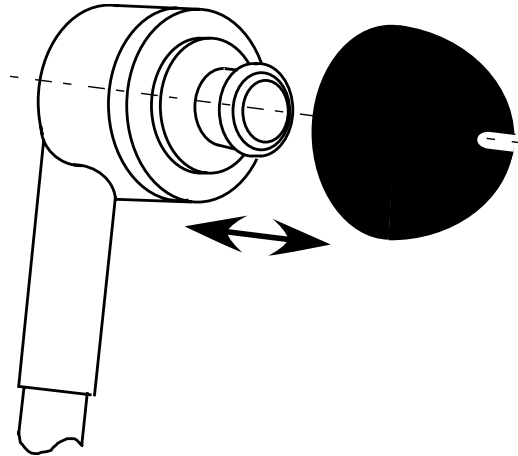

You can easily pull the ear adapters from the headphones. Clean the ear adapters with mild soapy water. Dry the ear adapters well before replacing them.

Changing silicone ear adapters

The skin-neutral silicone ear adapters must be changed if they are very contaminated.

You can easily remove the ear adapters by gently pulling them away from the headphones. New ear adapters are easily pushed into place.

Important information

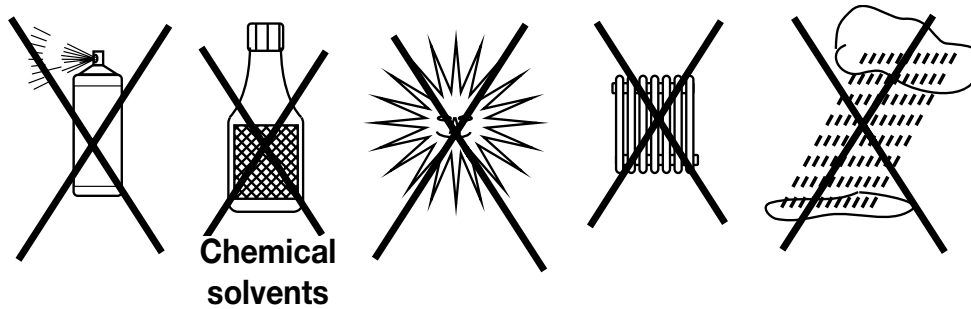

The equipment is designed for listening to domestic audio sources. Other uses are outside the scope of use for this product. Damage or contamination caused to the equipment caused by use not in accordance with these instructions is excluded from the warranty. The equipment is not waterproof and should be kept away from all fluids. Do not place near any heat sources. Do not place any items on top of the equipment that may cause it to malfunction.

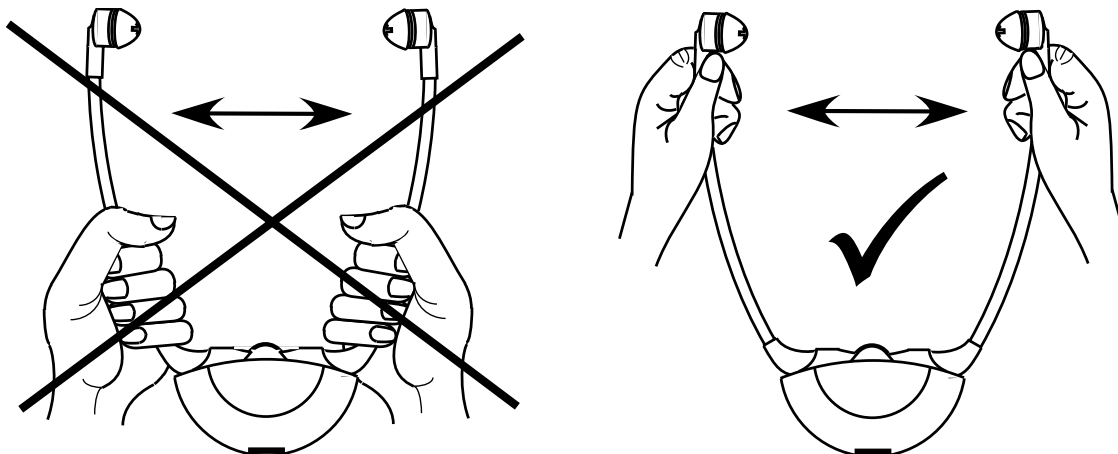

Warranty

Swing digital is designed to have high reliability. Should a fault occur please refer to the troubleshooting guide, if this does not resolve the problem please contact your retailer or the manufacturer directly for further help before returning items.

The warranty covers free repair as well as free return shipment, where applicable. Where possible, please send the complete system equipment in the original packaging.

This warranty does not cover misuse, improper handling or attempted repairs by unauthorised persons (quality seal broken). Warranty repairs will only be carried out if proof of purchase is provided to the retailer or manufacturer.

Environmental information/disposal



Disposal of used electrical and electronic devices (to be applied in countries of the European Union and other European countries with a separate collection system for these devices). The symbol on the product or on its packing indicates that this product must not be treated as normal household waste, but that it must be returned to a recycling point of acceptance for electrical and electronic devices or that it must be disposed in a Yellow Bin. You are protecting the environment and the health of your fellow man by contributing to the correct disposal. The environment and health are endangered by incorrect disposal.

Material recycling helps to reduce the consumption of raw materials.

Additional information about recycling of this product can be obtained from your community, the municipal disposal companies or the shop where you bought the product.

Battery

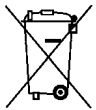

The provided battery can be recycled. Please dispose the battery through the battery container or the specialist shop. Please dispose only discharged batteries to guarantee environmental protection.



This devices adheres to the requirements of the following EU directives:

- 1999/5/EG R&TTE directive
- 2002/95/EG RoHS directive
- 2002/96/EG WEEE directive
- 2004/108/EG EMV directive
- 2006/95/EG low voltage directive

The conformity of the a.m. directives is confirmed by the CE mark on the device. CE conformity declarations are available on the Internet from www.humantechnik.com.

Subject to technical changes

Troubleshooting guide

Symptoms	Cause	Resolution
LED charge indicators do not illuminate despite battery being inserted correctly into receiver or charging bay	Transmitter has no electricity from mains supply.	Check whether the power supply is connected to the electrical outlet of the house and at the plug and whether the electrical outlet is working and that no fuse was triggered.
The charge indicator is not illuminated, despite the fact that the batteries are inserted.	No contact between battery and charging station in transmitter.	Insert the batteries correctly and completely into transmitter.
Receiver charge indicator is not illuminated, despite the fact that the receiver is inserted in the charging cradle.	No contact between battery in the receiver and the charging cradle in transmitter.	Insert the batteries fully in the correct orientation into transmitter or the charging cradle.
	No battery inserted into the receiver.	Insert battery in receiver.
Receiver does not work – no sound received.	The transmitter is not connected correctly to TV set or other audio device.	Check the cable and the plug connection between the sender and the TV or HiFi device. Use the operating instructions of the TV or HiFi device to check whether the headphone output is correctly connected.
	TV set or HiFi system is not switched on.	
	Pairing was lost	Re-pair transmitter and receiver

Symptoms	Cause	Resolution
Receiver does not work – no sound received.	Receiver is not switched on. (SWING digital LR)	Switch the receiver on by using the ON/OFF switch on the back. (SWING digital LR)
	No battery in receiver.	Insert battery in receiver.
	Battery in receiver is discharged or not charged.	Charge battery or insert fully charged battery.
The sound transmission is bad, noisy or it is distorted.	Receiver is too far away from transmitter.	Move receiver closer to the transmitter.
The sound transmission is distorted.	The battery is almost exhausted.	Charge battery or insert fully charged battery.
The sound transmission is distorted for a short time and works well afterwards	Receiver is too far away from transmitter. The environment (e.g. walls) distort the reception.	Move the receiver closer to the transmitter.
The battery only lasts a short time before needing recharging	Battery is not completely charged or defective.	Charge battery or insert new or fully charged battery.

Technical Data

Modulation process	Stereo
Carrier frequency:	2.4 GHz
Tone frequency transmission range:	20 – 20,000 Hz
Distortion factor:	< 1 %
Signal/interference ratio:	> 90 dB
Working range:	0° C – 55° C

Headphones receiver:

Operating hours:	app. 5 h
Maximum volume:	app. 125 dB
Weight:	app. 58 g

Transmitter:

Power consumption:	app. 4.5 VA
Power supply:	12 VDC.
Power supply:	100–240 Volt 50–60 Hz
Weight:	app. 43 g

THIS DEVICE COMPLIES WITH PART 15 OF THE FCC RULES. OPERATION IS SUBJECT TO THE FOLLOWING TWO CONDITIONS: (1) THIS DEVICE MAY NOT CAUSE HARMFUL INTERFERENCE, AND (2) THIS DEVICE MUST ACCEPT ANY INTERFERENCE RECEIVED, INCLUDING INTERFERENCE THAT MAY CAUSE UNDESIRE OPERATION.

NOTE: THE GRANTEE IS NOT RESPONSIBLE FOR ANY CHANGES OR MODIFICATIONS NOT EXPRESSLY APPROVED BY THE PARTY RESPONSIBLE FOR COMPLIANCE. SUCH MODIFICATIONS COULD VOID THE USER' S AUTHORITY TO OPERATE THE EQUIPMENT.