

FCC Radio Test Report

FCC ID: XMR202005SC200RNA

This report concerns: Original Grant

Project No. : 2005H018
Equipment : Multi-mode Smart LTE Module
Brand Name : Quectel
Test Model : SC200R-NA
Series Model : N/A
Applicant : Quectel Wireless Solutions Co., Ltd.
Address : Building 5, Shanghai Business Park Phase III (Area B), No.1016 Tianlin Road, Minhang District, Shanghai, China 200233.
Manufacturer : Quectel Wireless Solutions Co., Ltd.
Address : Building 5, Shanghai Business Park Phase III (Area B), No.1016 Tianlin Road, Minhang District, Shanghai, China 200233.
Date of Receipt : May 08, 2020
Date of Test : May 08, 2020 ~ Jun. 05, 2020
Issued Date : Aug. 10, 2020
Report Version : R00
Test Sample : Engineering Sample No.: SH2020050840, SH2020050840-1
Standard(s) : 47 CFR FCC Part 22 Subpart H
47 CFR FCC Part 2
ANSI/TIA/EIA-603-E-2016
FCC KDB 971168 D01 Power Meas License Digital Systems v03r01

The above equipment has been tested and found compliance with the requirement of the relative standards by BTL Inc.

Krain. Wu

Prepared by : Krain Wu

Ryan. Wang

Approved by : Ryan Wang



Certificate # 5123.03

Add: No. 29, Jintang Road, Tangzhen Industry Park, Pudong New Area, Shanghai 201210, China

TEL: +86-021-61765666

Web: www.newbtl.com

Declaration

BTL represents to the client that testing is done in accordance with standard procedures as applicable and that test instruments used has been calibrated with standards traceable to international standard(s) and/or national standard(s).

BTL's reports apply only to the specific samples tested under conditions. It is manufacture's responsibility to ensure that additional production units of this model are manufactured with the identical electrical and mechanical components. **BTL** shall have no liability for any declarations, inferences or generalizations drawn by the client or others from **BTL** issued reports.

The report must not be used by the client to claim product certification, approval, or endorsement by NIST, A2LA, or any agency of the U.S. Government.

This report is the confidential property of the client. As a mutual protection to the clients, the public and ourselves, the test report shall not be reproduced, except in full, without our written approval.

BTL's laboratory quality assurance procedures are in compliance with the **ISO/IEC 17025** requirements, and accredited by the conformity assessment authorities listed in this test report.

BTL is not responsible for the sampling stage, so the results only apply to the sample as received.

The information, data and test plan are provided by manufacturer which may affect the validity of results, so it is manufacturer's responsibility to ensure that the apparatus meets the essential requirements of applied standards and in all the possible configurations as representative of its intended use.

Limitation

For the use of the authority's logo is limited unless the Test Standard(s)/Scope(s)/Item(s) mentioned in this test report is (are) included in the conformity assessment authorities acceptance respective.

Please note that the measurement uncertainty is provided for informational purpose only and is not use in determining the Pass/Fail results.

Table of Contents	Page
REPORT ISSUED HISTORY	5
1 . SUMMARY OF TEST RESULTS	6
1.1 TEST FACILITY	7
1.2 MEASUREMENT UNCERTAINTY	7
1.3 TEST ENVIRONMENT CONDITIONS	7
2 . GENERAL INFORMATION	8
2.1 GENERAL DESCRIPTION OF EUT	8
2.2 DESCRIPTION OF TEST MODES AND TEST CONDITION	10
2.3 BLOCK DIGRAM SHOWING THE CONFIGURATIONOFSYSTEMTESTED	13
2.4 DESCRIPTION OF SUPPORT UNITS	13
3 . TEST RESULT	14
3.1 OUTPUT POWER MEASUREMENT	14
3.1.1 LIMIT	14
3.1.2 TEST PROCEDURE	14
3.1.3 TEST SETUP LAYOUT	14
3.1.4 TEST DEVIATION	14
3.1.5 TEST RESULTS	14
3.2 OCCUPIED BANDWIDTH MEASUREMENT	15
3.2.1 TEST PROCEDURE	15
3.2.2 TEST SETUP LAYOUT	15
3.2.3 TEST DEVIATION	15
3.2.4 TEST RESULTS	15
3.3 CONDUCTED EMISSIONS MEASUREMENT	16
3.3.1 LIMIT	16
3.3.2 TEST PROCEDURES	16
3.3.3 TEST SETUP LAYOUT	16
3.3.4 TEST DEVIATION	16
3.3.5 TEST RESULTS	16
3.4 RADIATED EMISSIONS MEASUREMENT	17
3.4.1 LIMIT	17
3.4.2 TEST PROCEDURES	17
3.4.3 TEST SETUP LAYOUT	18
3.4.4 TEST DEVIATION	19
3.4.5 TEST RESULTS (9KHZ TO 30MHZ)	19
3.4.6 TEST RESULTS (30MHZ TO 1000MHZ)	19
3.4.7 TEST RESULTS (ABOVE 1000MHZ)	19
3.5 BAND EDGE MEASUREMENT	20
3.5.1 LIMIT	20

Table of Contents	Page
3.5.2 TEST PROCEDURES	20
3.5.3 TEST SETUP LAYOUT	20
3.5.4 TEST DEVIATION	20
3.5.5 TEST RESULTS	20
3.6 PEAK TO AVERAGE RATIO MEASUREMENT	21
3.6.1 LIMIT	21
3.6.2 TEST PROCEDURES	21
3.6.3 TEST SETUP LAYOUT	21
3.6.4 TEST DEVIATION	21
3.6.5 TEST RESULTS	21
3.7 FREQUENCY STABILITY MEASUREMENT	22
3.7.1 LIMIT	22
3.7.2 TEST PROCEDURES	22
3.7.3 TEST SETUP LAYOUT	22
3.7.4 TEST DEVIATION	22
3.7.5 TEST RESULTS	22
4. LIST OF MEASUREMENT EQUIPMENTS	23
APPENDIX A - OUTPUT POWER	25
APPENDIX B - OCCUPIED BANDWIDTH	36
APPENDIX C - CONDUCTED EMISSIONS	56
APPENDIX D - RADIATED SPURIOUS EMISSIONS (9KHZ TO 30MHZ)	64
APPENDIX E - RADIATED EMISSION (30MHZ TO 1GHZ)	65
APPENDIX F - RADIATED EMISSION (ABOVE 1GHZ)	72
APPENDIX G - BAND EDGE	87
APPENDIX H - PEAK TO AVERAGE RATIO	98
APPENDIX I - FREQUENCY STABILITY	109

REPORT ISSUED HISTORY

Report Version	Description	Issued Date
R00	Original Issue.	Aug. 10, 2020

1. SUMMARY OF TEST RESULTS

Test procedures according to the technical standard(s):

FCC Part 22 Subpart H & Part 2			
Standard(s) Section	Test Item	Judgment	Remark
2.1046 22.913(a)(5)	Effective Radiated Power	PASS	-----
2.1049	Occupied Bandwidth	PASS	-----
2.1051 22.917(a)	Conducted Spurious Emissions	PASS	-----
2.1053 22.917(a)	Radiated Spurious Emissions	PASS	-----
22.917(a)	Band Edge Measurements	PASS	-----
-	Peak To Average Ratio	PASS	Record Only
2.1055 22.355	Frequency Stability	PASS	-----

Note:

For the verdict, the "N/A" denotes "not applicable", the "N/T" denotes "not tested".

1.1 TEST FACILITY

The test facilities used to collect the test data in this report is at the location of No. 29, Jintang Road, Tangzhen Industry Park, Pudong New Area, Shanghai 201210, China.

BTL's Test Firm Registration Number for FCC: 476765

BTL's Designation Number for FCC: CN1241

1.2 MEASUREMENT UNCERTAINTY

ISO/IEC 17025 requires that an estimate of the measurement uncertainties associated with the emissions test results be included in the report. The measurement uncertainties given below are based on a 95% confidence level (based on a coverage factor (k=2)).

The BTL measurement uncertainty as below table:

A. Radiated Measurement :

Test Site	Method	Measurement Frequency Range	Ant. H / V	U,(dB)
SH-CB01	CISPR	9KHz ~ 30MHz	V	3.79
		9KHz ~ 30MHz	H	3.57
		30MHz ~ 200MHz	V	4.12
		30MHz ~ 200MHz	H	3.20
		200MHz ~ 1,000MHz	V	3.12
		200MHz ~ 1,000MHz	H	3.18

Test Site	Method	Measurement Frequency Range	U,(dB)
SH-CB01 (3m)	CISPR	1GHz ~ 6GHz	4.40
		6GHz ~ 18GHz	4.86

Test Site	Method	Measurement Frequency Range	U,(dB)
SH-CB01 (3m)	CISPR	18 ~ 26.5 GHz	3.64
		26.5 ~ 40 GHz	3.78

Note: Unless specifically mentioned, the uncertainty of measurement has not been taken into account to declare the compliance or non-compliance to the specification.

1.3 TEST ENVIRONMENT CONDITIONS

Test Item	Temperature	Humidity	Test Voltage	Tested By
Output Power & ERP	23 °C	60%	DC 3.8V	Forest Li
Occupied Bandwidth	23 °C	60%	DC 3.8V	Forest Li
Conducted Spurious Emissions	23 °C	60%	DC 3.8V	Forest Li
Radiated Spurious Emissions	23 °C	46%	DC 3.8V	Forest Li
Band Edge	23 °C	60%	DC 3.8V	Forest Li
Peak to Average Ratio	23 °C	60%	DC 3.8V	Forest Li
Frequency Stability	Normal and Extreme			Forest Li

2. GENERAL INFORMATION

2.1 GENERAL DESCRIPTION OF EUT

Equipment	Multi-mode Smart LTE Module	
Brand Name	Quectel	
Test Model	SC200R-NA	
Series Model	N/A	
Model Difference(s)	N/A	
Software Version	SC200RNANAR04A01	
Hardware Version	R1.0	
Power Source	DC power supply.	
Power Rating	DC 3.8V	
Antenna Type	Dipole	
Antenna Gain	WCDMA Band V	2.53 dBi
	LTE Band 5	
	LTE Band 26	2.13 dBi
Modulation Type	WCDMA	UL: QPSK DL: QPSK
	LTE	UL: QPSK,16QAM DL: QPSK,16QAM
Operation Frequency	WCDMA Band V	826.4MHz ~ 846.6MHz
	LTE Band 5 (Channel Bandwidth: 1.4MHz)	824.7 MHz ~ 848.3 MHz
	LTE Band 5 (Channel Bandwidth: 3MHz)	825.5 MHz ~ 847.5 MHz
	LTE Band 5 (Channel Bandwidth: 5MHz)	826.5 MHz ~ 846.5 MHz
	LTE Band 5 (Channel Bandwidth: 10MHz)	829.0 MHz ~ 844.0 MHz
	LTE Band 26 (Channel Bandwidth: 1.4MHz)	824.7 MHz ~ 848.3 MHz
	LTE Band 26 (Channel Bandwidth: 3MHz)	825.5 MHz ~ 847.5 MHz
	LTE Band 26 (Channel Bandwidth: 5MHz)	826.5 MHz ~ 846.5 MHz
	LTE Band 26 (Channel Bandwidth: 10MHz)	829 MHz ~ 844 MHz
LTE Band 26 (Channel Bandwidth: 15MHz)	831.5 MHz ~ 841.5 MHz	

Max. ERP Power	WCDMA Band V	QPSK	23.33	dBm
	LTE Band 5 (Channel Bandwidth: 1.4MHz)	QPSK	24.39	dBm
		16QAM	23.75	dBm
	LTE Band 5 (Channel Bandwidth: 3MHz)	QPSK	24.46	dBm
		16QAM	23.91	dBm
	LTE Band 5 (Channel Bandwidth: 5MHz)	QPSK	24.35	dBm
		16QAM	23.16	dBm
	LTE Band 5 (Channel Bandwidth: 10MHz)	QPSK	24.76	dBm
		16QAM	23.83	dBm
	LTE Band 26 (Channel Bandwidth: 1.4MHz)	QPSK	24.23	dBm
		16QAM	23.60	dBm
	LTE Band 26 (Channel Bandwidth: 3MHz)	QPSK	24.30	dBm
		16QAM	23.54	dBm
	LTE Band 26 (Channel Bandwidth: 5MHz)	QPSK	24.26	dBm
		16QAM	22.88	dBm
	LTE Band 26 (Channel Bandwidth: 10MHz)	QPSK	24.46	dBm
16QAM		23.07	dBm	
LTE Band 26 (Channel Bandwidth: 15MHz)	QPSK	24.22	dBm	
	16QAM	23.61	dBm	

Note:

1. For a more detailed features description, please refer to the manufacturer's specifications or the user's manual.

2.2 DESCRIPTION OF TEST MODES AND TEST CONDITION

Pre-Scan has been conducted to determine the worst-case mode from all possible combinations between available modulations, data rates, XYZ axis and antenna ports

The worst case was found when positioned on X-plane for EIRP and X-axis for radiated emission.

Following channel(s) was (were) selected for the final test as listed below:

WCDMA MODE			
Test Item	Available Channel	Tested Channel	Mode
ERP	4132 to 4233	4132, 4182, 4233	WCDMA
Output Power	4132 to 4233	4132, 4182, 4233	WCDMA
Conducted Emission	4132 to 4233	4182	WCDMA
Radiated Emission	4132 to 4233	4182	WCDMA
Band Edge	4132 to 4233	4132, 4233	WCDMA
Peak to Average Ratio	4132 to 4233	4132, 4182, 4233	WCDMA
Frequency Stability	4132 to 4233	4182	WCDMA

LTE BAND 5						
Test Item	Available Channel	Tested Channel	Channel Bandwidth	Modulation	Mode	
Output Power & ERP	20407 to 20643	20407, 20525, 20643	1.4MHz	QPSK, 16QAM	1RB/3RB/6RB	
	20415 to 20635	20415, 20525, 20635	3MHz	QPSK, 16QAM	1RB/8RB/15RB	
	20425 to 20625	20425, 20525, 20625	5MHz	QPSK, 16QAM	1RB/12RB/25RB	
	20450 to 20600	20450, 20525, 20600	10MHz	QPSK, 16QAM	1RB/25RB/50RB	
Occupied Bandwidth	20407 to 20643	20407, 20525, 20643	1.4MHz	QPSK, 16QAM	6 RB	
	20415 to 20635	20415, 20525, 20635	3MHz	QPSK, 16QAM	15 RB	
	20425 to 20625	20425, 20525, 20625	5MHz	QPSK, 16QAM	25 RB	
	20450 to 20600	20450, 20525, 20600	10MHz	QPSK, 16QAM	50 RB	
Conducted Emission	20407 to 20643	20525	1.4MHz	QPSK	1 RB	
	20425 to 20625	20525	5MHz	QPSK	1 RB	
	20450 to 20600	20525	10MHz	QPSK	1 RB	
Radiated Emission	20407 to 20643	20525	1.4MHz	QPSK	1 RB	
	20425 to 20625	20525	5MHz	QPSK	1 RB	
	20450 to 20600	20525	10MHz	QPSK	1 RB	
Band Edge	20407 to 20643	20407	1.4MHz	QPSK	1 RB 6 RB	
		20643	1.4MHz	QPSK	1 RB 6 RB	
	20415 to 20635	20415	3MHz	QPSK	1 RB 15 RB	
		20635	3MHz	QPSK	1 RB 15 RB	
	20425 to 20625	20425	5MHz	QPSK	1 RB 25 RB	
		20625	5MHz	QPSK	1 RB 25 RB	
	20450 to 20600	20450	10MHz	QPSK	1 RB 50 RB	
		20600	10MHz	QPSK	1 RB 50 RB	
	Peak To Average Ratio	20407 to 20643	20407, 20525, 20643	1.4MHz	QPSK, 16QAM	1 RB
		20415 to 20635	20415, 20525, 20635	3MHz	QPSK, 16QAM	1 RB
		20425 to 20625	20425, 20525, 20625	5MHz	QPSK, 16QAM	1 RB
		20450 to 20600	20450, 20525, 20600	10MHz	QPSK, 16QAM	1 RB
Frequency Stability	20407 to 20643	20525	1.4MHz	QPSK	1 RB	
	20415 to 20635	20525	3MHz	QPSK	1 RB	
	20425 to 20625	20525	5MHz	QPSK	1 RB	
	20450 to 20600	20525	10MHz	QPSK	1 RB	

LTE BAND 26 MODE					
Test Item	Available Channel	Tested Channel	Channel Bandwidth	Modulation	Mode
Output Power & ERP	26797 to 27033	26797, 26915, 27033	1.4MHz	QPSK, 16QAM,	1RB/3RB/6RB
	26805 to 27025	26805, 26915, 27025	3MHz	QPSK, 16QAM,	1RB/8RB/15RB
	26815 to 27015	26815, 26915, 27015	5MHz	QPSK, 16QAM,	1RB/12RB/25RB
	26840 to 26990	26840, 26915, 26990	10MHz	QPSK, 16QAM,	1RB/25RB/50RB
	26865 to 26965	26865, 26915, 26965	15MHz	QPSK, 16QAM,	1RB/36RB/75RB
Occupied Bandwidth	26797 to 27033	26797, 26915, 27033	1.4MHz	QPSK, 16QAM,	6RB
	26805 to 27025	26805, 26915, 27025	3MHz	QPSK, 16QAM,	15RB
	26815 to 27015	26815, 26915, 27015	5MHz	QPSK, 16QAM,	25RB
	26840 to 26990	26840, 26915, 26990	10MHz	QPSK, 16QAM,	50RB
	26865 to 26965	26865, 26915, 26965	15MHz	QPSK, 16QAM,	75RB
Conducted Spurious Emissions	26815 to 27015	226915	1.4MHz	QPSK	1RB
	26815 to 27015	226915	5MHz	QPSK	1RB
	26865 to 26965	226915	15MHz	QPSK	1RB
Radiated Spurious Emissions	26815 to 27015	226915	1.4MHz	QPSK	1RB
	26815 to 27015	226915	5MHz	QPSK	1RB
	26865 to 26965	226915	15MHz	QPSK	1RB
Band Edge	26797 to 27033	26797, 27033	1.4MHz	QPSK	1RB
					6RB
	26805 to 27025	26805, 27025	3MHz	QPSK	1RB
					15RB
	26815 to 27015	26815, 27015	5MHz	QPSK	1RB
					25RB
26840 to 26990	26840, 26990	10MHz	QPSK	1RB	
				50RB	
26865 to 26965	26865, 26965	15MHz	QPSK	1RB	
				75RB	
Peak To Average Ratio	26797 to 27033	26797, 26915, 27033	1.4MHz	QPSK, 16QAM,	6 RB
	26805 to 27025	26805, 26915, 27025	3MHz	QPSK, 16QAM,	15 RB
	26815 to 27015	26815, 26915, 27015	5MHz	QPSK, 16QAM,	25 RB
	26840 to 26990	26840, 26915, 26990	10MHz	QPSK, 16QAM,	50 RB
	26865 to 26965	26865, 26915, 26965	15MHz	QPSK, 16QAM,	75 RB
Frequency Stability	26797 to 27033	226915	1.4MHz	QPSK	1RB
	26805 to 27025	226915	3MHz	QPSK	1RB
	26815 to 27015	226915	5MHz	QPSK	1RB
	26840 to 26990	226915	10MHz	QPSK	1RB
	26865 to 26965	226915	15MHz	QPSK	1RB

Note: The low frequency, which started from 9 kHz to 30MHz, was pre-scanned and the result which was 20dB lower than the limit line was not reported.

2.3 BLOCK DIGRAM SHOWING THE CONFIGURATION OF SYSTEM TESTED

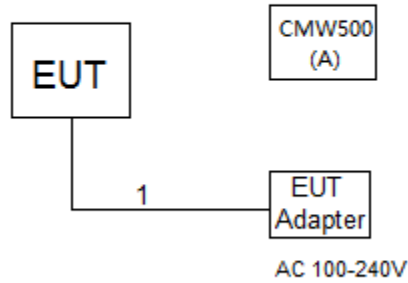

2.4 DESCRIPTION OF SUPPORT UNITS

The EUT has been tested as an independent unit together with other necessary accessories or support units. The following support units or accessories were used to form a representative test configuration during the tests.

Item	Equipment	Mfr/Brand	Model/Type No.	Series No.
1	CMW500	N/A	N/A	131463

Item	Cable Type	Shielded Type	Ferrite Core	Length
1	DC Cable	N/A	N/A	1.5m

3. TEST RESULT

3.1 OUTPUT POWER MEASUREMENT

3.1.1 LIMIT

Mobile / Portable station are limited to 7 watts e.r.p.

3.1.2 TEST PROCEDURE

The testing follows FCC KDB 971168 v03r01 Section 5.

EIRP/ ERP:

1. EIRP= Output Power +Antenan gain
ERP power= EIPR power-2.15dBi.

Output Power:

The EUT was set up for the maximum power with WCDMA and LTE link data modulation and link up with simulator.

Set the EUT to transmit under low, middle and high channel and record the power level shown on simulator.

3.1.3 TEST SETUP LAYOUT

Output Power Measurement

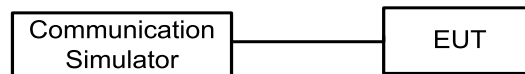

3.1.4 TEST DEVIATION

No deviation

3.1.5 TEST RESULTS

Please refer to the Appendix A.

3.2 OCCUPIED BANDWIDTH MEASUREMENT

3.2.1 TEST PROCEDURE

The testing follows FCC KDB 971168 v03r01 Section 4.

1. The EUT makes a call to the communication simulator. All measurements were done at low, middle and high operational frequency range. The communication simulator station system controlled a EUT to export maximum output power under transmission mode and specific channel frequency. Use OBW measurement function of Spectrum analyzer to measure 99 % occupied bandwidth and 26dB bandwidth.
2. The EUT was connected to spectrum analyzer and system simulator via a power divider.
3. $RBW=(1\% \sim 5\%)*EBW$
 $VBW \geq 3*RBW$
4. Set spectrum analyzer with Peak detector.

3.2.2 TEST SETUP LAYOUT

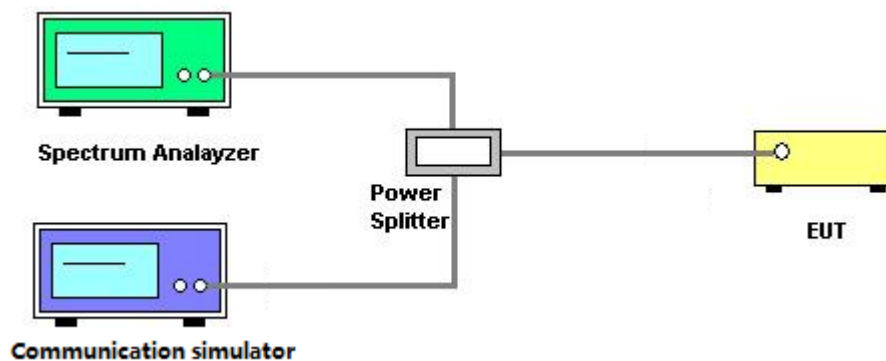

3.2.3 TEST DEVIATION

No deviation

3.2.4 TEST RESULTS

Please refer to the Appendix B.

3.3 CONDUCTED EMISSIONS MEASUREMENT

3.3.1 LIMIT

The power of any emission outside of the authorized operating frequency ranges must be attenuated below the transmitting power (P) by a factor of at least $43 + 10 \log(P)$ dB. The emission limit equal to -13dBm.

3.3.2 TEST PROCEDURES

1. The testing follows FCC KDB 971168 v03r01 Section 6.0.
2. The EUT was connected to spectrum analyzer and system simulator via a power divider.
3. The band edges of low and high channels for the highest RF powers were measured. Set RBW \geq 1% EBW in the 1MHz band immediately outside and adjacent to the band edge.
4. Set spectrum analyzer with RMS detector.
5. The RF fundamental frequency should be excluded against the limit line in the operating frequency band.
6. The limit line is derived from $43+10\log(P)$ dB below the transmitter power P(Watts)
 $=P(W)-[43+10\log(P)](dB)$
 $=[30+10\log(P)](dBm)-[43+10\log(P)](dB)$
 $=-13dBm$

3.3.3 TEST SETUP LAYOUT

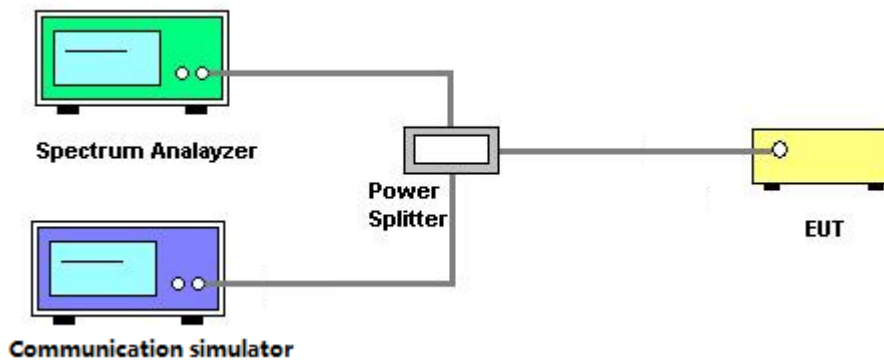

3.3.4 TEST DEVIATION

No deviation

3.3.5 TEST RESULTS

Please refer to the Appendix C.

3.4 RADIATED EMISSIONS MEASUREMENT

3.4.1 LIMIT

The power of any emission outside of the authorized operating frequency ranges must be attenuated below the transmitting power (P) by a factor of at least $43 + 10 \log(P)$ dB. The emission limit equal to -13dBm.

3.4.2 TEST PROCEDURES

The testing follows FCC KDB 971168 v03r01 Section 6.2.

1. Substitution method is used for E.I.R.P measurement. In the semi-anechoic chamber, EUT placed on the 0.8m height of Turn Table, rotated the table around 360 degrees to search the maximum radiation power and receiver antenna shall be rotated vertical and horizontal polarization and moved height from 1m to 4m to find the maximum polar radiated power. The "Read Value" is the spectrum reading the maximum power value.
2. The substitution horn antenna is substituted for EUT at the same position and signals generator export the CW signal to the substitution antenna via a TX cable. Rotated the Turn Table and moved receiving antenna to find the maximum radiation power. Adjust output power level of S.G to get a Value of spectrum reading equal to "Read Value " of step a. Record the power level of S.G
3. EIRP = Output power level of S.G – TX cable loss + Antenna gain of substitution horn.
4. E.R.P power can be calculated form E.I.R.P power by subtracting the gain of dipole, E.R.P power = E.I.P.R power - 2.15dBi.
5. The resolution bandwidth and video bandwidth of test receiver/spectrum analyzer is 1MHz/3MHz.

3.4.3 TEST SETUP LAYOUT**Below 30MHz**

Absorbers

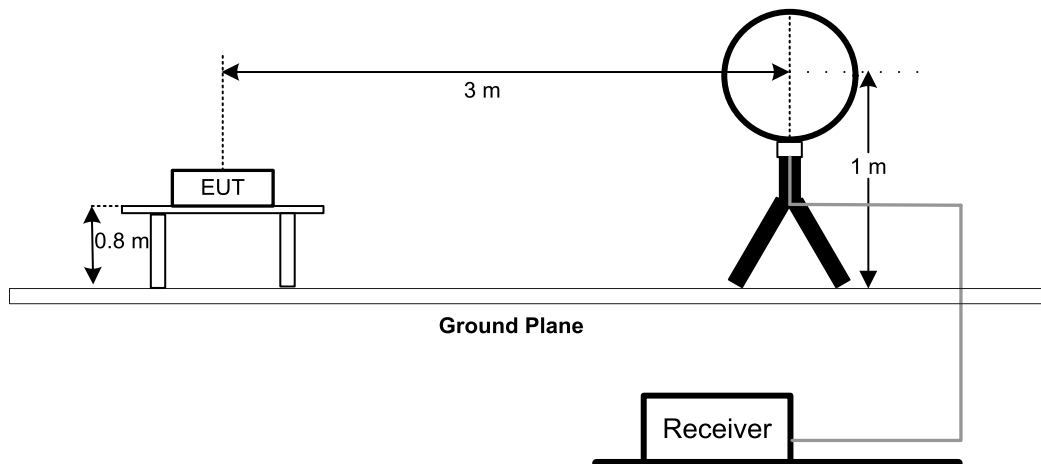
**30MHz to 1GHz**

Absorbers

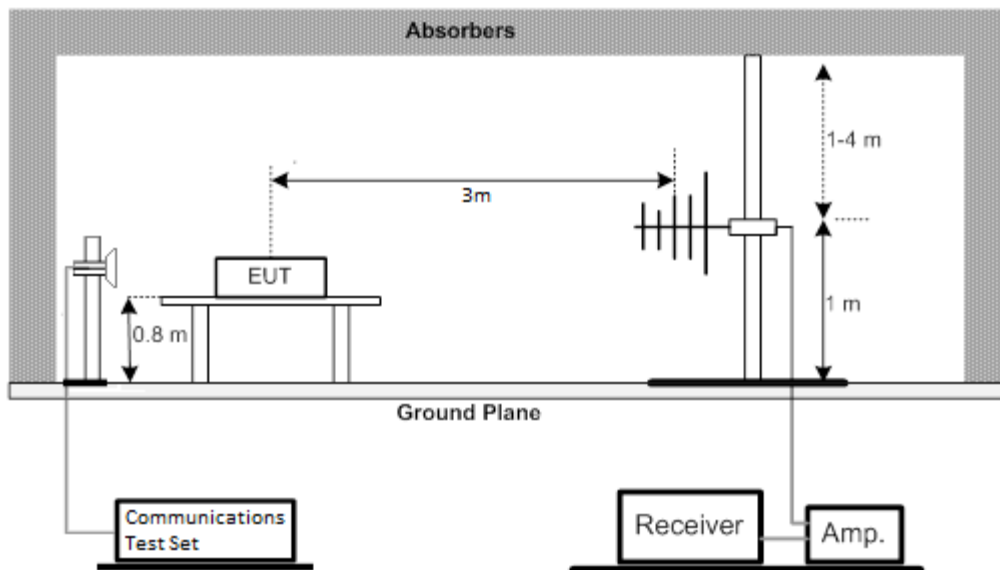

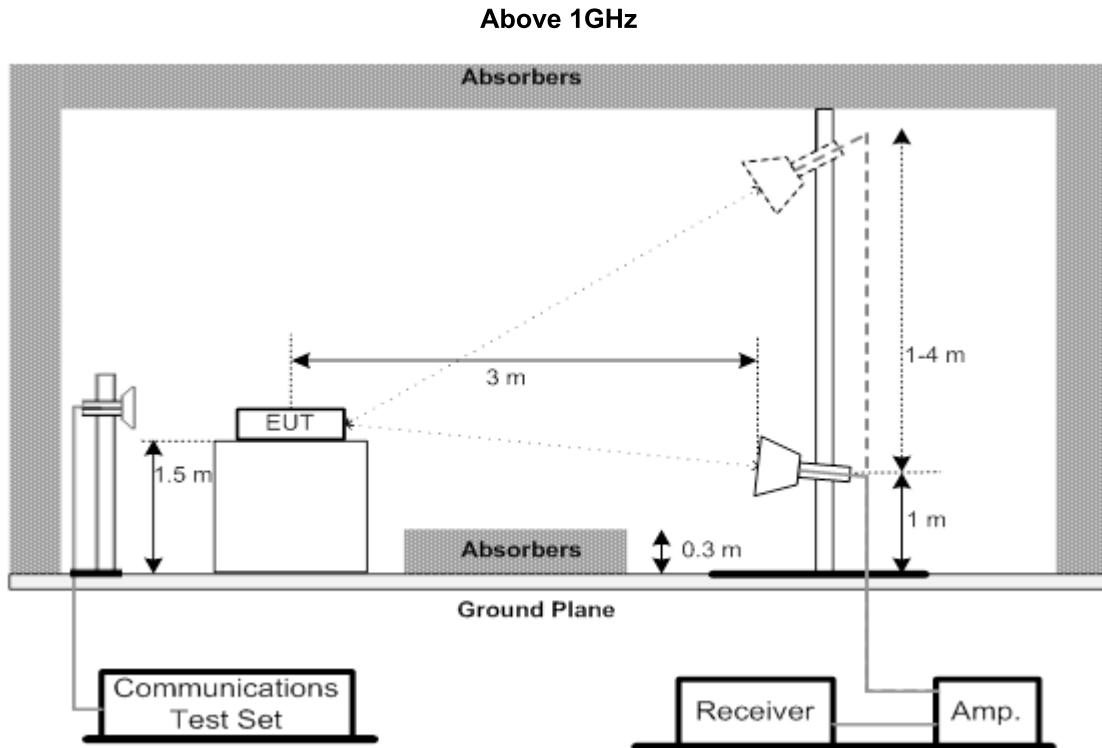

3.4.4 TEST DEVIATION

No deviation

3.4.5 TEST RESULTS (9KHZ TO 30MHZ)

Please refer to the APPENDIX D.

3.4.6 TEST RESULTS (30MHZ TO 1000MHZ)

Please refer to the APPENDIX E.

3.4.7 TEST RESULTS (ABOVE 1000MHZ)

Please refer to the APPENDIX F.

3.5 BAND EDGE MEASUREMENT

3.5.1 LIMIT

A Power of any emission outside of the authorized operating frequency ranges must be attenuated below the transmitting power (P) by a factor of at least $43 + 10 \log(P)$ dB. In the 1 MHz bands immediately outside and adjacent to the frequency block a resolution bandwidth of at least one percent of the emission bandwidth of the fundamental emission of the transmitter may be employed.

3.5.2 TEST PROCEDURES

The testing follows FCC KDB 971168 v03r01 Section 6.

1. All measurements were done at low and high operational frequency range.
2. The center frequency of spectrum is the band edge frequency and span is 10MHz. RB of the spectrum is 100kHz and VB of the spectrum is 300kHz (WCDMA).
3. The center frequency of spectrum is the band edge frequency and span is 2MHz. RB of the spectrum is 15kHz and VB of the spectrum is 43kHz (LTE Bandwidth 1.4MHz).
4. The center frequency of spectrum is the band edge frequency and span is 2MHz. RB of the spectrum is 30kHz and VB of the spectrum is 91kHz (LTE Bandwidth 3MHz).
5. The center frequency of spectrum is the band edge frequency and span is 2MHz. RB of the spectrum is 51kHz and VB of the spectrum is 150kHz (LTE Bandwidth 5MHz).
6. The center frequency of spectrum is the band edge frequency and span is 2MHz. RB of the spectrum is 100kHz and VB of the spectrum is 300kHz (LTE Bandwidth 10MHz).
7. The center frequency of spectrum is the band edge frequency and span is 2MHz. RB of the spectrum is 150kHz and VB of the spectrum is 470kHz (LTE Bandwidth 15MHz).
8. The center frequency of spectrum is the band edge frequency and span is 2MHz. RB of the spectrum is 200kHz and VB of the spectrum is 620kHz (LTE Bandwidth 20MHz).

3.5.3 TEST SETUP LAYOUT

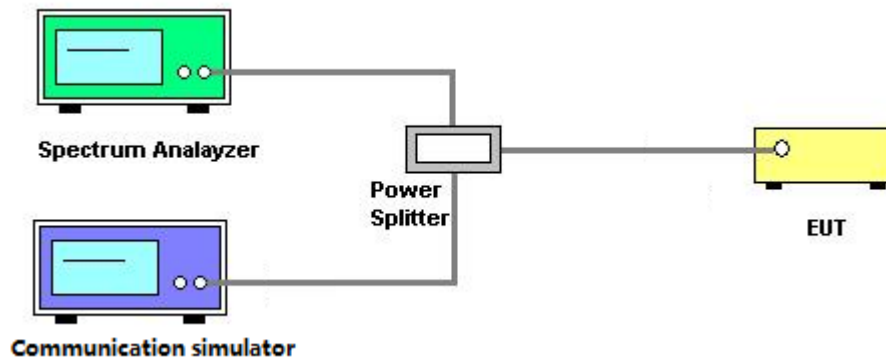

3.5.4 TEST DEVIATION

No deviation

3.5.5 TEST RESULTS

Please refer to the Appendix G.

3.6 PEAK TO AVERAGE RATIO MEASUREMENT

3.6.1 LIMIT

In measuring transmissions in this band using an average power technique, the peak to-average ratio (PAR) of the transmission may not exceed 13 dB.

3.6.2 TEST PROCEDURES

The testing follows FCC KDB 971168 v03r01 Section 5.7.

1. Set resolution/measurement bandwidth \geq signal's occupied bandwidth;
2. Set the number of counts to a value that stabilizes the measured CCDF curve;
3. Record the maximum PAPR level associated with a probability of 0.1%.

3.6.3 TEST SETUP LAYOUT

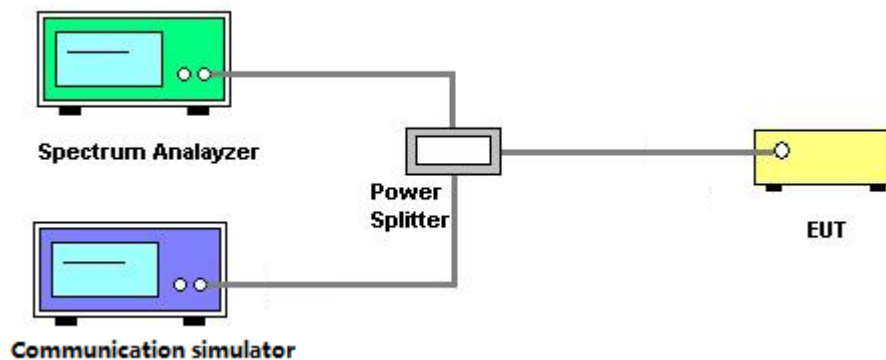

3.6.4 TEST DEVIATION

No deviation

3.6.5 TEST RESULTS

Please refer to the Appendix H.

3.7 FREQUENCY STABILITY MEASUREMENT

3.7.1 LIMIT

± 1.5 ppm is for base and fixed station. ± 2.5 ppm is for mobile station.

3.7.2 TEST PROCEDURES

The testing follows FCC KDB 971168 v03r01 Section 9.

1. Device is placed at the oven room. The oven room could control the temperatures and humidity. Power warm up is at least 15 min and power applied should perform before recording frequency error.
2. EUT is connected the external power supply to control the DC input power. The test voltage range is from minimum to maximum working voltage. Each step shall be record the frequency error rate.
3. The temperature range step is 10 degrees in this test items. All temperature levels shall be hold the ± 0.5 °C during the measurement testing. The each temperature step shall be at least 0.5 hours, consider the EUT could be test under the stability condition.
4. The frequency error was recorded frequency error from the communication simulator.

3.7.3 TEST SETUP LAYOUT

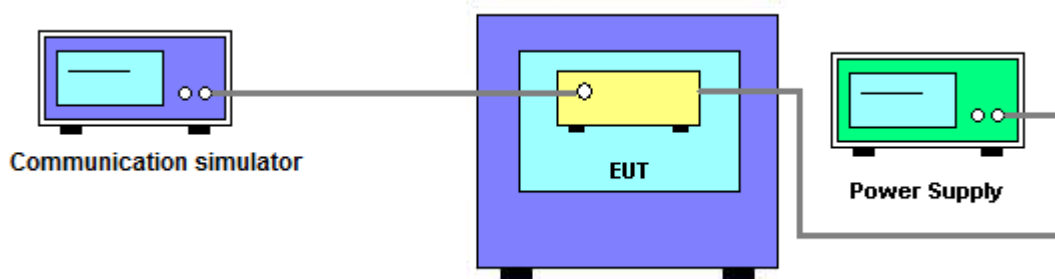

3.7.4 TEST DEVIATION

No deviation

3.7.5 TEST RESULTS

Please refer to the Appendix I.

4. LIST OF MEASUREMENT EQUIPMENTS

Radiated Emission Measurement(30M-1G)					
Item	Kind of Equipment	Manufacturer	Type No.	Serial No.	Calibrated until
1	TRILOG Broadband Antenna	Schwarzbeck	VULB 9168	719	Apr. 02, 2021
2	Pre-Amplifier	emci	EMC9135	980400	Mar. 21, 2021
3	MXE EMI Receiver	Keysight	N9038A	MY57150106	Mar. 21, 2021
4	Test Cable	emci	EMC104-SM-SM-7000	170330	Apr. 13, 2021
5	Test Cable	emci	EMC104-SM-SM-1000	170331	Apr. 13, 2021
6	Test Cable	emci	EMC104-SM-NM-3500	170621	Apr. 13, 2021
7	Measurement Software	Farad	EZ-EMC Ver.NB-03A1-01	N/A	Apr. 13, 2021
8	Wideband Radio Communication Test	R&S	CMW500	131463	Sep. 01, 2020

Radiated Emission Measurement(1G-18G)					
Item	Kind of Equipment	Manufacturer	Type No.	Serial No.	Calibrated until
1	Pre-Amplifier	emci	EMC184045SE	980409	Apr. 02, 2021
2	Pre-Amplifier	emci	EMC012645SE	980421	May. 11, 2021
3	Pre-Amplifier	emci	EMC9135	980400	Mar. 21, 2021
4	Double Ridged Broadband Horn Antenna	Schwarzbeck	BBHA 9120D	9120D-1787	Apr. 13, 2021
5	Double-Ridged Waveguide Horn Antenna	ETS-Lindgren	3116C	00203919	Apr. 13, 2021
6	TRILOG Broadband Antenna	Schwarzbeck	VULB 9168	719	Apr. 13, 2021
7	Cable	N/A	EMC102-SM-SM-6000	170336	N/A
8	Wideband Radio Communication Test	R&S	CMW500	131463	Sep. 01, 2020

Conducted Emission & Band Edge & Occupied Bandwidth Measurement					
	Kind of Equipment	Manufacturer	Type No.	Serial No.	Calibrated until
1	8960 SERIES 10 WIRELESS COMMUNICATIONS TEST SET	Agilent	E5515C	GB45070942	Sep. 01, 2020
2	Spectrum Analyzer	R&S	FSP40	100626	May. 06, 2021
3	EXA Spectrum Analyzer	Keysight	N9010A	MY56480579	Mar. 21, 2021
4	Power Divider	JUK	PD-2SF-2060	N/A	N/A

Frequency Stability Measurement					
	Kind of Equipment	Manufacturer	Type No.	Serial No.	Calibrated until
1	8960 SERIES 10 WIRELESS COMMUNICATIONS TEST SET	Agilent	E5515C	GB45070942	Sep. 01, 2020
2	Spectrum Analyzer	R&S	FSP40	100626	May. 06, 2021
3	EXA Spectrum Analyzer	Keysight	N9010A	MY56480579	Mar. 21, 2021
4	Power Divider	JUK	PD-2SF-2060	N/A	N/A
5	Temperature And Humidity Box	Blue pand	BPHS-120B	170616454	Sep. 01, 2020

Remark: "N/A" denotes no model name, serial no. or calibration specified.

All calibration period of equipment list is one year.

APPENDIX A - OUTPUT POWER

Output Power (dBm):

Modulation	Band	WCDMA Band V		
	Tx Channel	4132CH	4182CH	4233CH
	Frequency	826.4MHz	836.4MHz	846.6MHz
QPSK	RMC 12.2K	22.43	22.69	22.77
	RMC 64K	22.52	22.70	22.95
	RMC 144K	22.48	22.87	22.73
	RMC 384K	22.34	22.64	22.68

LTE Band / BW	Modulation	RB Size	RB Offset	Low CH	Mid CH	High CH
				20407CH	20525CH	20643CH
				824.7MHz	836.5MHz	848.3MHz
5 / 1.4M	QPSK	1	0	23.88	23.87	23.48
		1	2	23.79	23.91	23.64
		1	5	23.82	23.87	23.53
		3	0	23.86	23.88	23.75
		3	1	23.89	24.01	23.69
		3	2	23.84	23.89	23.73
		6	0	22.84	22.94	22.81
	16QAM	1	0	22.89	23.31	23.14
		1	2	22.89	23.36	23.26
		1	5	23.01	23.28	22.63
		3	0	23.37	23.35	22.94
		3	1	23.30	23.30	22.87
		3	2	23.30	23.25	22.66
		6	0	21.98	22.21	21.90

LTE Band / BW	Modulation	RB Size	RB Offset	Low CH	Mid CH	High CH
				20415CH	20525CH	20635CH
				825.5MHz	836.5MHz	847.5MHz
5 / 3M	QPSK	1	0	23.83	24.08	23.97
		1	7	23.99	24.00	23.97
		1	14	23.86	23.79	23.47
		8	0	22.73	22.96	22.94
		8	4	22.72	22.91	22.90
		8	7	22.64	22.93	22.77
		15	0	22.71	22.95	22.91
	16QAM	1	0	22.92	23.40	22.99
		1	7	22.90	23.53	23.02
		1	14	22.82	23.43	22.84
		8	0	21.96	22.25	22.01
		8	4	21.94	22.20	21.98
		8	7	21.98	22.29	21.79
		15	0	21.86	22.21	21.77

LTE Band / BW	Modulation	RB Size	RB Offset	Low CH	Mid CH	High CH
				20425CH	20525CH	20625CH
				826.5MHz	836.5MHz	846.5MHz
5 / 5M	QPSK	1	0	23.83	23.74	23.82
		1	13	23.89	23.84	23.90
		1	24	23.97	23.76	23.56
		12	0	22.78	23.13	22.86
		12	6	22.92	23.02	23.01
		12	11	22.95	22.94	22.92
	16QAM	25	0	22.90	23.11	22.88
		1	0	22.34	22.45	22.59
		1	13	22.40	22.49	22.62
		1	24	22.78	22.32	22.43
		12	0	21.86	22.01	22.04
		12	6	21.97	21.91	22.07
		12	11	21.93	21.84	22.09
		25	0	21.84	22.19	21.95

LTE Band / BW	Modulation	RB Size	RB Offset	Low CH	Mid CH	High CH
				20450CH	20525CH	20600CH
				829.0MHz	836.5MHz	844.0MHz
5 / 10M	QPSK	1	0	23.96	23.81	23.82
		1	25	24.38	24.17	24.11
		1	49	24.30	23.48	23.65
		25	0	22.78	23.05	22.78
		25	13	22.97	23.02	22.94
		25	25	23.10	22.88	22.88
		50	0	22.87	22.97	22.86
	16QAM	1	0	22.94	23.35	22.84
		1	25	23.45	23.44	23.01
		1	49	23.35	23.18	22.80
		25	0	21.83	22.16	21.98
		25	13	21.95	22.16	22.14
		25	25	22.00	22.00	22.08
		50	0	21.97	22.09	21.94

LTE Band / BW	Modulation	RB Siset	RB Offset	Low CH	Mid CH	High CH
				26797 CH	26915 CH	27033 CH
				824.7 MHz	836.5 MHz	848.3 MHz
26 / 1.4M	QPSK	1	0	23.77	24.10	23.96
		1	2	24.15	24.21	24.16
		1	5	24.06	24.11	24.01
		3	0	24.05	24.16	24.17
		3	1	24.25	23.85	24.20
		3	3	23.73	23.77	24.06
	16QAM	6	0	22.73	23.05	23.11
		1	0	22.85	22.73	23.35
		1	2	23.00	22.96	23.32
		1	5	23.04	22.90	22.92
		3	0	23.50	23.21	23.23
		3	1	23.62	23.14	23.15
		3	3	23.50	22.62	23.12
		6	0	22.63	22.17	22.05

LTE Band / BW	Modulation	RB Siset	RB Offset	Low CH	Mid CH	High CH
				26805 CH	26915 CH	27025 CH
				825.5 MHz	836.5 MHz	847.5 MHz
26 / 3M	QPSK	1	0	24.22	23.63	24.08
		1	7	24.32	24.09	23.87
		1	14	24.24	23.94	24.04
		8	0	22.74	23.10	23.05
		8	3	23.20	23.29	23.10
		8	7	22.86	23.19	23.01
		15	0	22.97	23.05	23.13
	16QAM	1	0	22.80	23.33	23.10
		1	7	23.55	23.56	23.17
		1	14	23.40	23.54	23.14
		8	0	22.34	22.05	22.06
		8	3	22.22	22.34	22.11
		8	7	22.13	22.08	21.94
		15	0	21.93	22.10	22.17

LTE Band / BW	Modulation	RB Siset	RB Offset	Low CH	Mid CH	High CH
				26815 CH	26915 CH	27015 CH
				826.5 MHz	836.5 MHz	846.5 MHz
26 / 5M	QPSK	1	0	24.00	23.75	23.90
		1	12	24.02	23.98	24.13
		1	24	24.28	23.94	23.88
		12	0	23.15	22.87	23.18
		12	6	23.03	23.37	23.14
		12	13	23.33	22.99	23.20
		25	0	22.84	22.84	23.04
	16QAM	1	0	22.49	22.43	22.90
		1	12	22.42	22.87	22.82
		1	24	22.56	22.52	22.85
		12	0	22.18	22.06	22.09
		12	6	22.18	21.82	22.13
		12	13	22.14	21.80	22.18
		25	0	22.04	22.09	21.95

LTE Band / BW	Modulation	RB Siset	RB Offset	Low CH	Mid CH	High CH
				26840 CH	26915 CH	26990 CH
				829 MHz	836.5 MHz	844MHz
26 / 10M	QPSK	1	0	24.03	24.11	23.98
		1	24	24.48	24.26	24.22
		1	49	24.13	23.86	23.93
		25	0	23.13	22.96	22.84
		25	12	23.28	23.16	23.20
		25	25	23.10	23.07	23.23
		50	0	23.22	23.04	23.14
	16QAM	1	0	22.87	23.31	22.80
		1	24	23.45	22.97	23.69
		1	49	23.26	22.86	22.99
		25	0	22.08	22.12	22.07
		25	12	22.23	22.23	22.18
		25	25	22.07	22.22	22.24
		50	0	22.15	22.14	22.03

LTE Band / BW	Modulation	RB Siset	RB Offset	Low CH	Mid CH	High CH
				26865 CH	26915 CH	26965 CH
				831.5 MHz	836.5 MHz	841.5 MHz
26 / 15M	QPSK	1	0	23.91	23.79	23.93
		1	37	23.93	23.97	23.83
		1	74	24.24	23.73	23.91
		36	0	23.14	22.92	22.99
		36	19	23.11	23.02	23.00
		36	39	23.03	22.96	23.13
		75	0	23.11	22.89	23.02
	16QAM	1	0	22.64	23.00	22.82
		1	37	22.77	23.63	22.85
		1	74	22.91	23.29	22.88
		36	0	22.35	21.86	22.00
		36	19	22.29	22.12	22.03
		36	39	22.06	22.05	22.15
		75	0	22.22	22.02	22.06

ERP Power (dBm):

Modulation	Band	WCDMA Band V		
	Tx Channel	4132CH	4182CH	4233CH
	Frequency	826.4MHz	836.4MHz	846.6MHz
QPSK	RMC 12.2K	22.81	23.07	23.15
	RMC 64K	22.90	23.08	23.33
	RMC 144K	22.86	23.25	23.11
	RMC 384K	22.72	23.02	23.06

LTE Band / BW	Modulation	RB Size	RB Offset	Low CH	Mid CH	High CH
				20407CH	20525CH	20643CH
				824.7MHz	836.5MHz	848.3MHz
5 / 1.4M	QPSK	1	0	24.26	24.25	23.86
		1	2	24.17	24.29	24.02
		1	5	24.20	24.25	23.91
		3	0	24.24	24.26	24.13
		3	1	24.27	24.39	24.07
		3	2	24.22	24.27	24.11
	16QAM	6	0	23.22	23.32	23.19
		1	0	23.27	23.69	23.52
		1	2	23.27	23.74	23.64
		1	5	23.39	23.66	23.01
		3	0	23.75	23.73	23.32
		3	1	23.68	23.68	23.25
		3	2	23.68	23.63	23.04
		6	0	22.36	22.59	22.28

LTE Band / BW	Modulation	RB Size	RB Offset	Low CH	Mid CH	High CH
				20415CH	20525CH	20635CH
				825.5MHz	836.5MHz	847.5MHz
5 / 3M	QPSK	1	0	24.21	24.46	24.35
		1	7	24.37	24.38	24.35
		1	14	24.24	24.17	23.85
		8	0	23.11	23.34	23.32
		8	4	23.10	23.29	23.28
		8	7	23.02	23.31	23.15
		15	0	23.09	23.33	23.29
	16QAM	1	0	23.30	23.78	23.37
		1	7	23.28	23.91	23.40
		1	14	23.20	23.81	23.22
		8	0	22.34	22.63	22.39
		8	4	22.32	22.58	22.36
		8	7	22.36	22.67	22.17
		15	0	22.24	22.59	22.15

LTE Band / BW	Modulation	RB Size	RB Offset	Low CH	Mid CH	High CH
				20425CH	20525CH	20625CH
				826.5MHz	836.5MHz	846.5MHz
5 / 5M	QPSK	1	0	24.21	24.12	24.20
		1	13	24.27	24.22	24.28
		1	24	24.35	24.14	23.94
		12	0	23.16	23.51	23.24
		12	6	23.30	23.40	23.39
		12	11	23.33	23.32	23.30
	16QAM	25	0	23.28	23.49	23.26
		1	0	22.72	22.83	22.97
		1	13	22.78	22.87	23.00
		1	24	23.16	22.70	22.81
		12	0	22.24	22.39	22.42
		12	6	22.35	22.29	22.45
		12	11	22.31	22.22	22.47
		25	0	22.22	22.57	22.33

LTE Band / BW	Modulation	RB Size	RB Offset	Low CH	Mid CH	High CH
				20450CH	20525CH	20600CH
				829.0MHz	836.5MHz	844.0MHz
5 / 10M	QPSK	1	0	24.34	24.19	24.20
		1	25	24.76	24.55	24.49
		1	49	24.68	23.86	24.03
		25	0	23.16	23.43	23.16
		25	13	23.35	23.40	23.32
		25	25	23.48	23.26	23.26
		50	0	23.25	23.35	23.24
	16QAM	1	0	23.32	23.73	23.22
		1	25	23.83	23.82	23.39
		1	49	23.73	23.56	23.18
		25	0	22.21	22.54	22.36
		25	13	22.33	22.54	22.52
		25	25	22.38	22.38	22.46
		50	0	22.35	22.47	22.32

LTE Band / BW	Modulation	RB Sizing	RB Offset	Low CH	Mid CH	High CH
				26797 CH	26915 CH	27033 CH
				824.7 MHz	836.5 MHz	848.3 MHz
26 / 1.4M	QPSK	1	0	23.75	24.08	23.94
		1	2	24.13	24.19	24.14
		1	5	24.04	24.09	23.99
		3	0	24.03	24.14	24.15
		3	1	24.23	23.83	24.18
		3	3	23.71	23.75	24.04
		6	0	22.71	23.03	23.09
	16QAM	1	0	22.83	22.71	23.33
		1	2	22.98	22.94	23.30
		1	5	23.02	22.88	22.90
		3	0	23.48	23.19	23.21
		3	1	23.60	23.12	23.13
		3	3	23.48	22.60	23.10
		6	0	22.61	22.15	22.03

LTE Band / BW	Modulation	RB Sizing	RB Offset	Low CH	Mid CH	High CH
				CH26805	CH26915	CH27025
				825.5MHz	836.5MHz	847.5MHz
26 / 3M	QPSK	1	0	24.20	23.61	24.06
		1	7	24.30	24.07	23.85
		1	14	24.22	23.92	24.02
		8	0	22.72	23.08	23.03
		8	3	23.18	23.27	23.08
		8	7	22.84	23.17	22.99
		15	0	22.95	23.03	23.11
	16QAM	1	0	22.78	23.31	23.08
		1	7	23.53	23.54	23.15
		1	14	23.38	23.52	23.12
		8	0	22.32	22.03	22.04
		8	3	22.20	22.32	22.09
		8	7	22.11	22.06	21.92
		15	0	21.91	22.08	22.15

LTE Band / BW	Modulation	RB Siset	RB Offset	Low CH	Mid CH	High CH
				26815 CH	26915 CH	27015 CH
				826.5 MHz	836.5MHz	846.5 MHz
26 / 5M	QPSK	1	0	23.98	23.73	23.88
		1	12	24.00	23.96	24.11
		1	24	24.26	23.92	23.86
		12	0	23.13	22.85	23.16
		12	6	23.01	23.35	23.12
		12	13	23.31	22.97	23.18
		25	0	22.82	22.82	23.02
	16QAM	1	0	22.47	22.41	22.88
		1	12	22.40	22.85	22.80
		1	24	22.54	22.50	22.83
		12	0	22.16	22.04	22.07
		12	6	22.16	21.80	22.11
		12	13	22.12	21.78	22.16
		25	0	22.02	22.07	21.93

LTE Band / BW	Modulation	RB Siset	RB Offset	Low CH	Mid CH	High CH
				26840 CH	26915 CH	26990 CH
				829MHz	836.5 MHz	844MHz
26 / 10M	QPSK	1	0	24.01	24.09	23.96
		1	24	24.46	24.24	24.20
		1	49	24.11	23.84	23.91
		25	0	23.11	22.94	22.82
		25	12	23.26	23.14	23.18
		25	25	23.08	23.05	23.21
		50	0	23.20	23.02	23.12
	16QAM	1	0	22.85	23.29	22.78
		1	24	23.43	22.95	23.67
		1	49	23.24	22.84	22.97
		25	0	22.06	22.10	22.05
		25	12	22.21	22.21	22.16
		25	25	22.05	22.20	22.22
		50	0	22.13	22.12	22.01

LTE Band / BW	Modulation	RB Siset	RB Offset	Low CH	Mid CH	High CH
				26865 CH	26915 CH	26965 CH
				831.5MHz	836.5MHz	841.5MHz
26 / 15M	QPSK	1	0	23.89	23.77	23.91
		1	37	23.91	23.95	23.81
		1	74	24.22	23.71	23.89
		36	0	23.12	22.90	22.97
		36	19	23.09	23.00	22.98
		36	39	23.01	22.94	23.11
		75	0	23.09	22.87	23.00
	16QAM	1	0	22.62	22.98	22.80
		1	37	22.75	23.61	22.83
		1	74	22.89	23.27	22.86
		36	0	22.33	21.84	21.98
		36	19	22.27	22.10	22.01
		36	39	22.04	22.03	22.13
		75	0	22.20	22.00	22.04

APPENDIX B - OCCUPIED BANDWIDTH

WCDMA Band V_WCDMA					
QPSK					
Channel	Frequency (MHz)	99% Occupied Bandwidth (MHz)	Channel	Frequency (MHz)	26dB Bandwidth (MHz)
4132	826.4	4.1675	4132	826.4	4.760
4182	836.4	4.1606	4182	836.4	4.769
4233	846.6	4.1503	4233	846.6	4.760



LTE Band 5_1.4M					
QPSK			16QAM		
Channel	Frequency (MHz)	99% Occupied Bandwidth (MHz)	Channel	Frequency (MHz)	99% Occupied Bandwidth (MHz)
20407	824.7	1.1047	20407	824.7	1.0950
20525	836.5	1.0866	20525	836.5	1.0885
20643	848.3	1.0953	20643	848.3	1.0886
Channel	Frequency (MHz)	26dB Bandwidth (MHz)	Channel	Frequency (MHz)	26dB Bandwidth (MHz)
20407	824.7	1.3120	20407	824.7	1.2840
20525	836.5	1.2840	20525	836.5	1.2680
20643	848.3	1.3150	20643	848.3	1.2550

Spectrum Plot

QPSK-20407

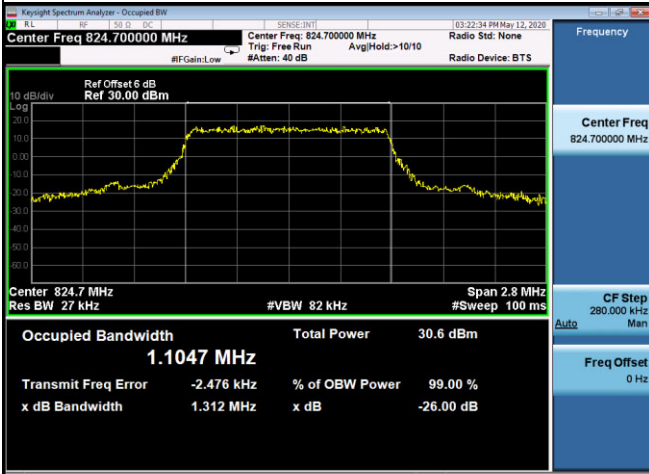

QPSK-20525

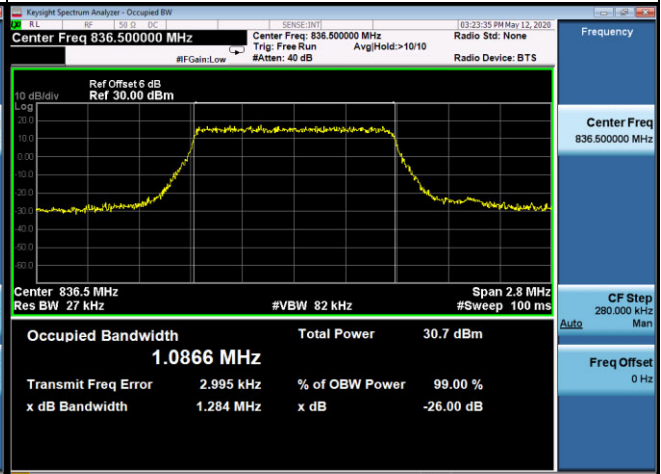

QPSK-20643

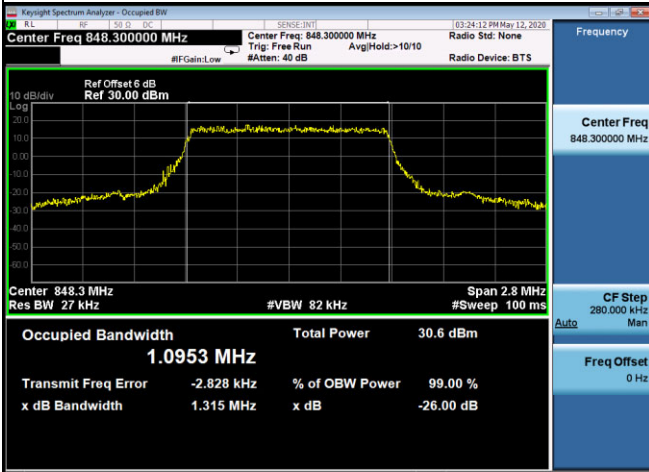

16QAM-20407

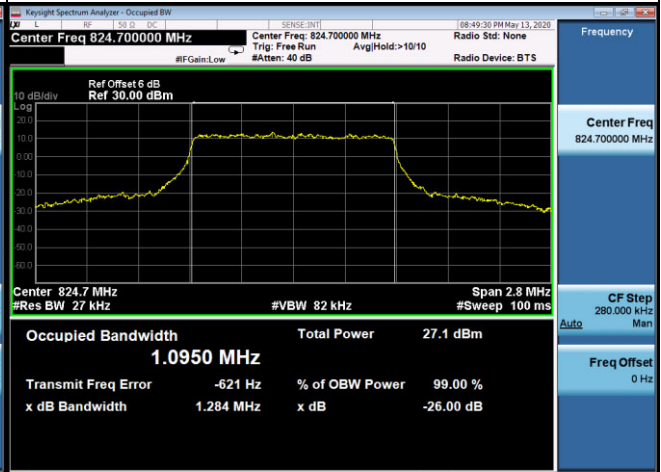

16QAM-20525



16QAM-20643



LTE Band 5_3M					
QPSK			16QAM		
Channel	Frequency (MHz)	99% Occupied Bandwidth (MHz)	Channel	Frequency (MHz)	99% Occupied Bandwidth (MHz)
20415	825.5	2.7011	20415	825.5	2.7106
20525	836.5	2.7007	20525	836.5	2.6988
20635	847.5	2.6965	20635	847.5	2.6971
Channel	Frequency (MHz)	26dB Bandwidth (MHz)	Channel	Frequency (MHz)	26dB Bandwidth (MHz)
20415	825.5	3.0190	20415	825.5	2.9640
20525	836.5	2.9780	20525	836.5	2.9430
20635	847.5	2.9570	20635	847.5	2.9330

Spectrum Plot

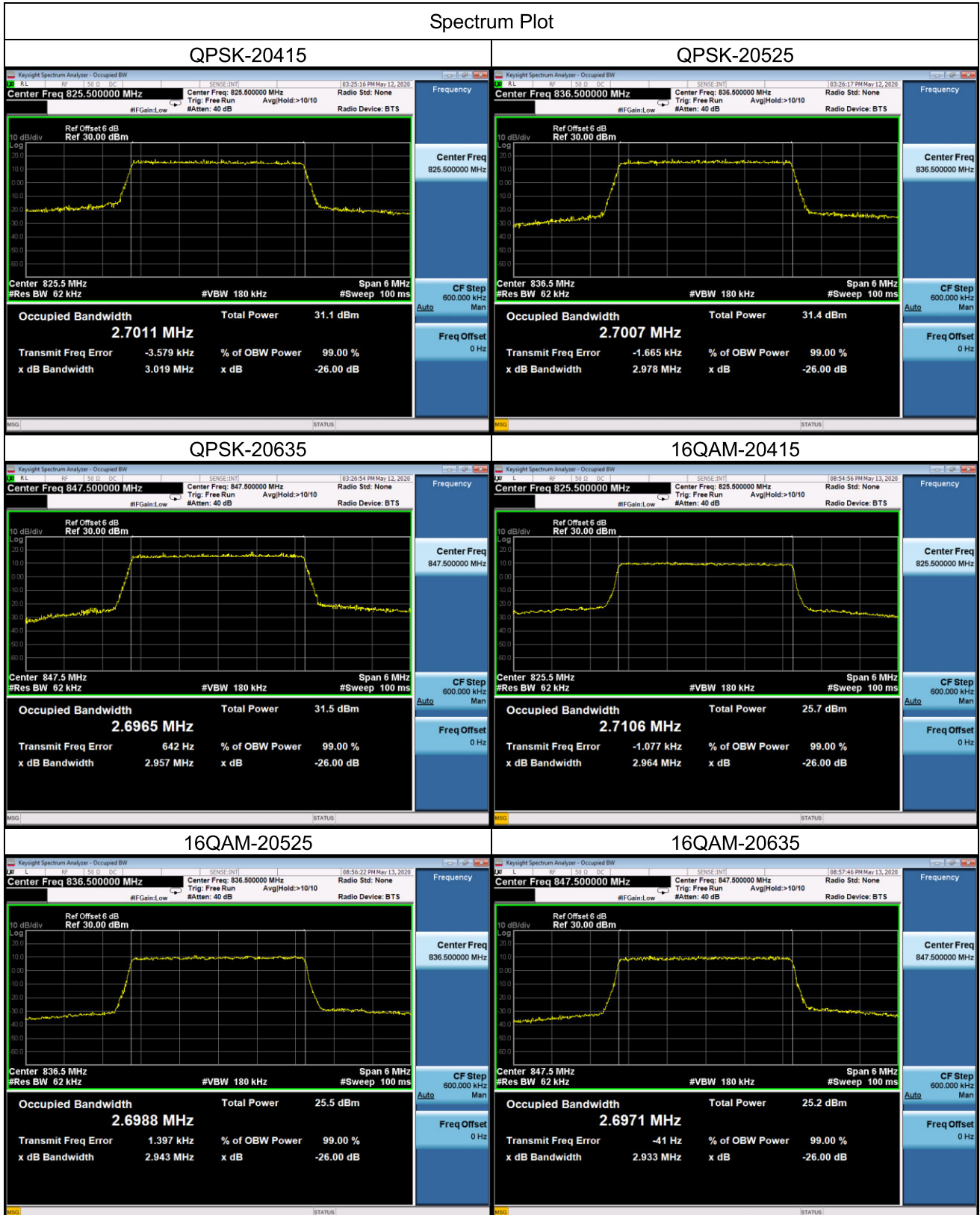

LTE Band 5_5M					
QPSK			16QAM		
Channel	Frequency (MHz)	99% Occupied Bandwidth (MHz)	Channel	Frequency (MHz)	99% Occupied Bandwidth (MHz)
20425	826.5	4.5211	20425	826.5	4.5075
20525	836.5	4.4997	20525	836.5	4.4867
20625	846.5	4.5025	20625	846.5	4.4964
Channel	Frequency (MHz)	26dB Bandwidth (MHz)	Channel	Frequency (MHz)	26dB Bandwidth (MHz)
20425	826.5	5.0410	20425	826.5	4.9060
20525	836.5	4.9640	20525	836.5	4.8110
20625	846.5	4.9480	20625	846.5	4.8310

Spectrum Plot

QPSK-20425

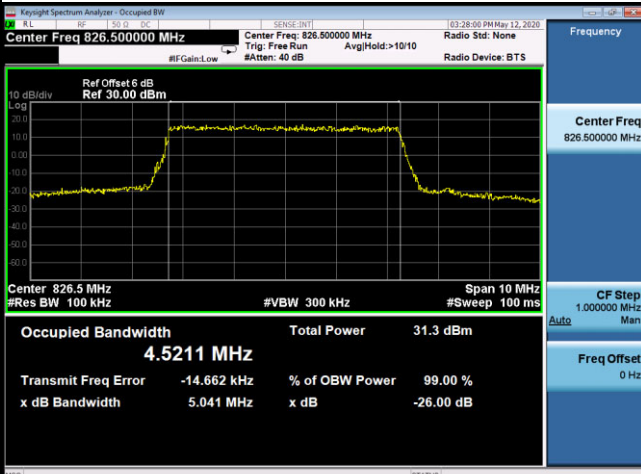

QPSK-20525

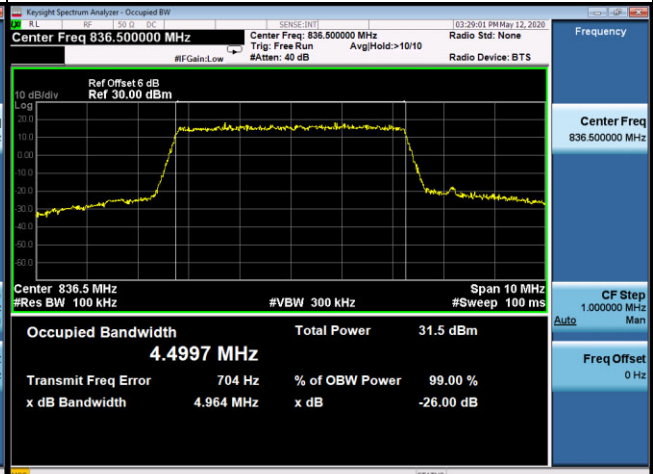

QPSK-20625

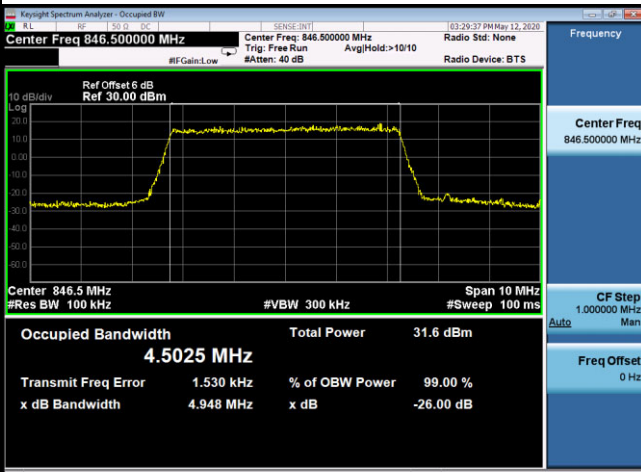

16QAM-20425

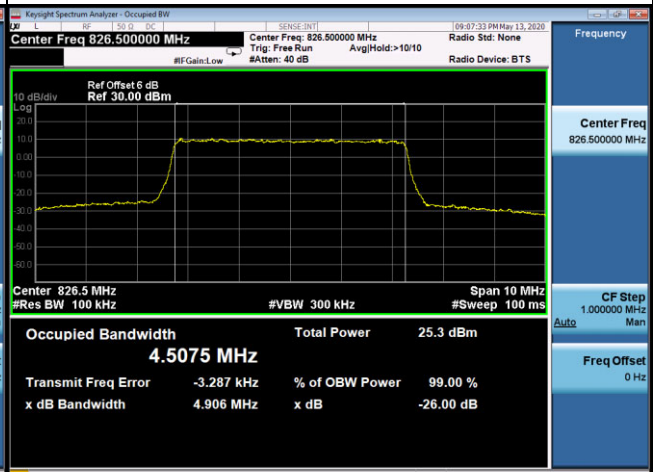

16QAM-20525

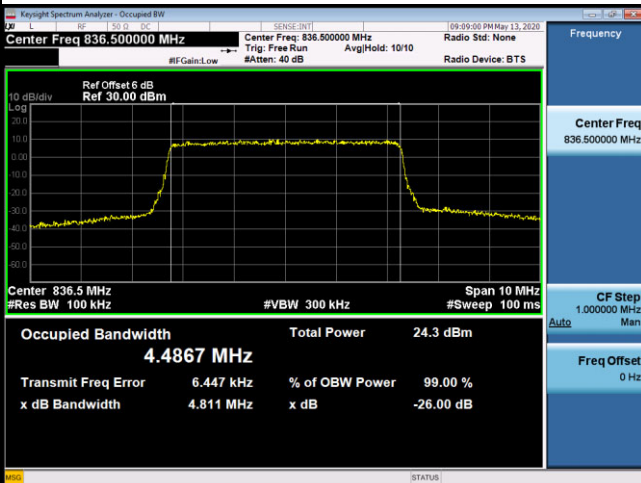

16QAM-20625

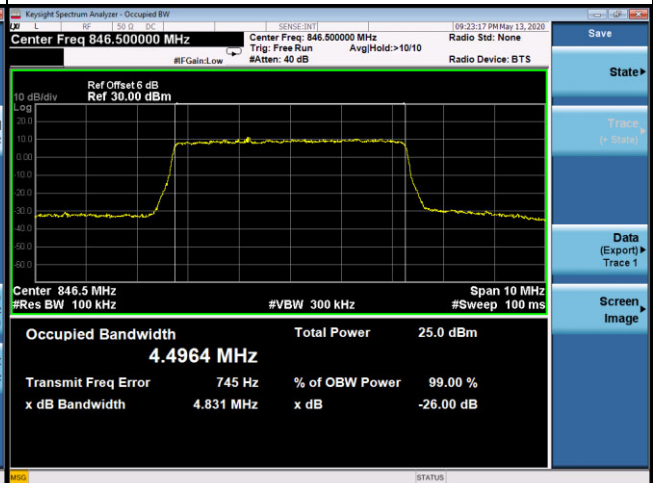

LTE Band 5_10M					
QPSK			16QAM		
Channel	Frequency (MHz)	99% Occupied Bandwidth (MHz)	Channel	Frequency (MHz)	99% Occupied Bandwidth (MHz)
20450	829.0	8.9978	20450	829.0	8.9915
20525	836.5	8.9175	20525	836.5	8.9157
20600	844.0	9.0210	20600	844.0	9.0044
Channel	Frequency (MHz)	26dB Bandwidth (MHz)	Channel	Frequency (MHz)	26dB Bandwidth (MHz)
20450	829.0	9.9210	20450	829.0	9.6330
20525	836.5	9.7430	20525	836.5	9.5280
20600	844.0	9.9440	20600	844.0	9.5440

Spectrum Plot

QPSK-20450

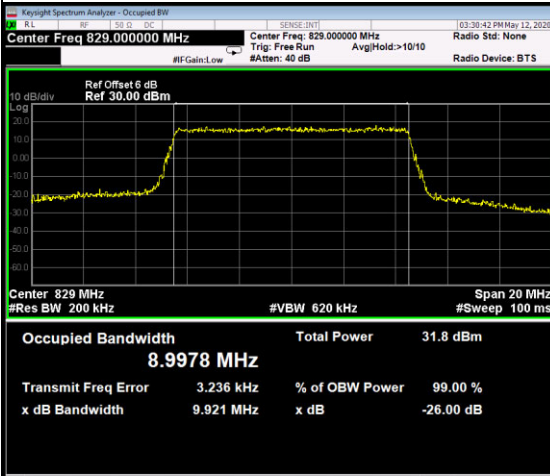

QPSK-20525

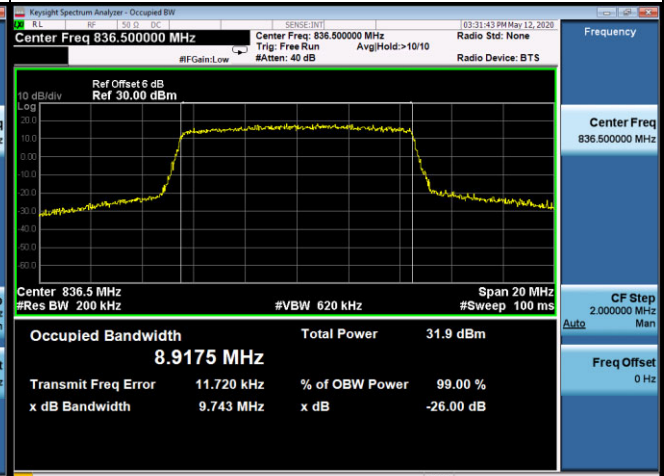

QPSK-20600

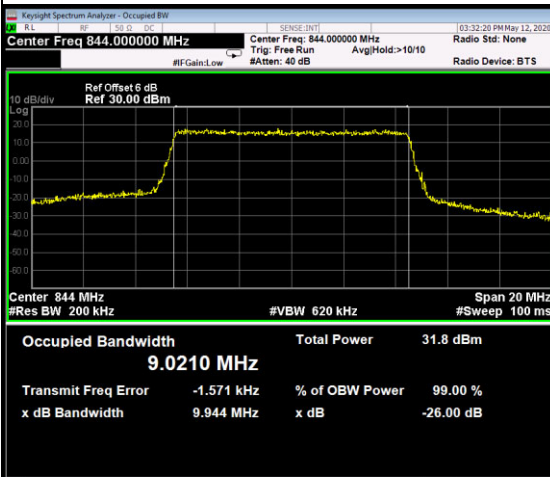

16QAM-20450

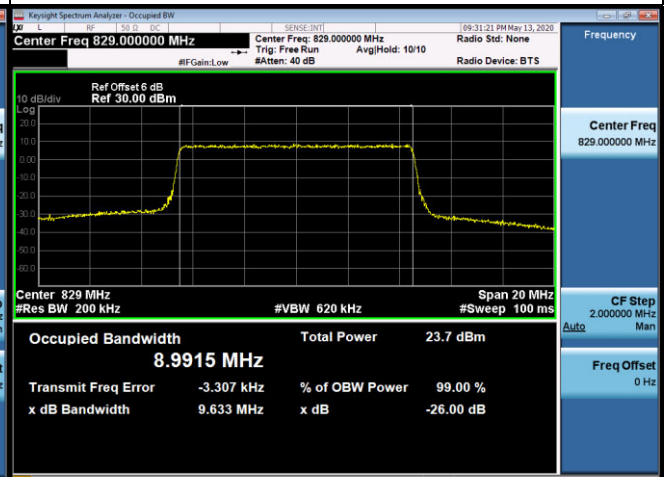

16QAM-20525

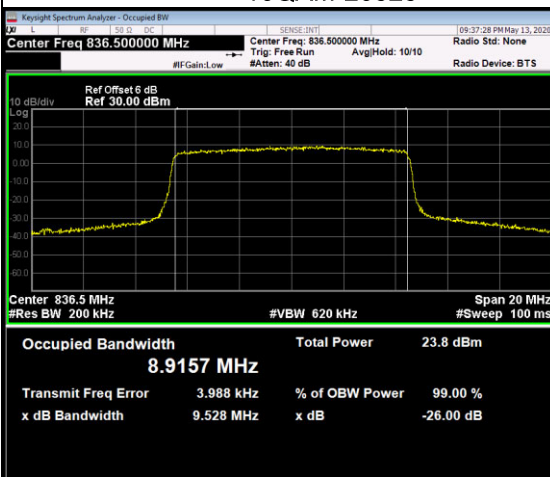

16QAM-20600

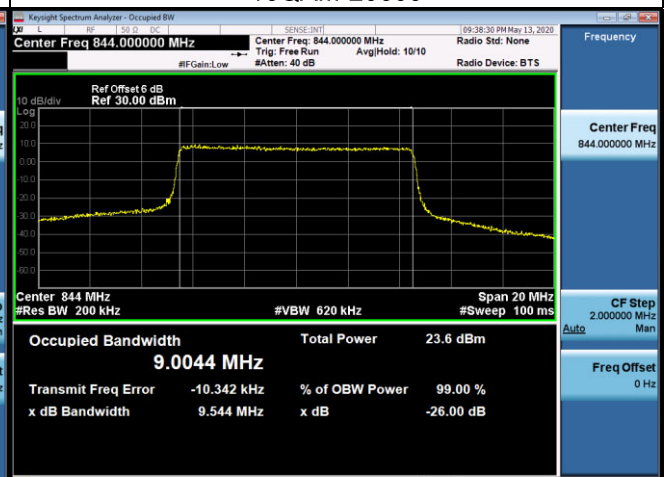

LTE Band 26_1.4M					
QPSK			16QAM		
Channel	Frequency (MHz)	99% Occupied Bandwidth (MHz)	Channel	Frequency (MHz)	99% Occupied Bandwidth (MHz)
26797	824.7	1.0820	26797	824.7	1.0828
26915	836.5	1.0826	26915	836.5	1.0799
27033	848.3	1.1001	27033	848.3	1.0885
Channel	Frequency (MHz)	26dB Bandwidth (MHz)	Channel	Frequency (MHz)	26dB Bandwidth (MHz)
26797	824.7	1.2530	26797	824.7	1.2500
26915	836.5	1.244	26915	836.5	1.2420
27033	848.3	1.3170	27033	848.3	1.2420

Spectrum Plot

QPSK-26797

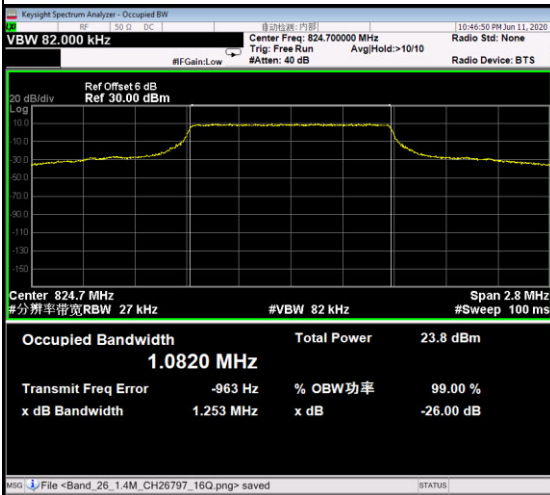

QPSK-26915



QPSK-27033

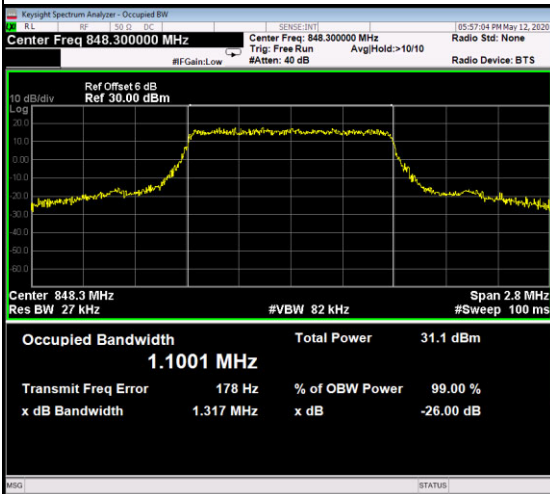

16QAM-26797

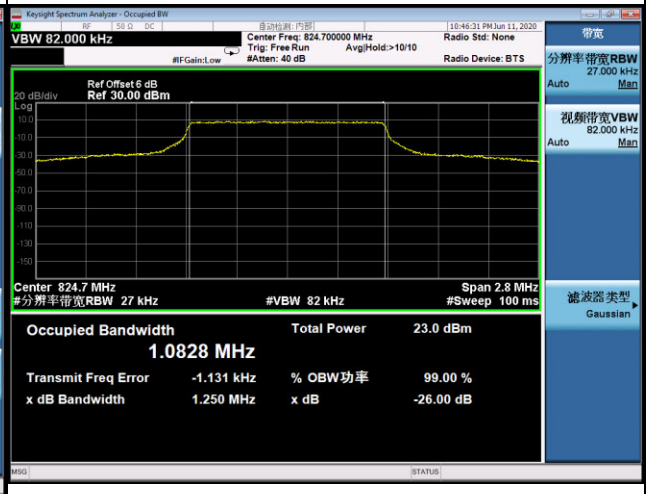

16QAM-26915

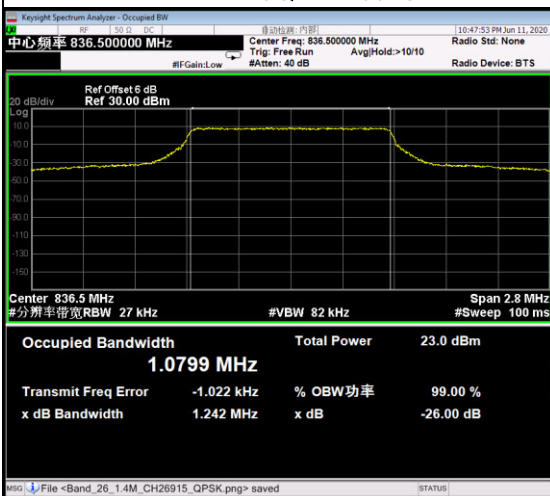

16QAM-27033

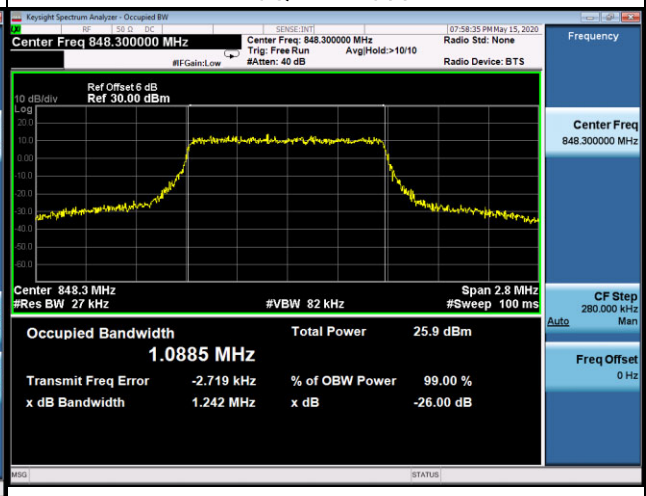

LTE Band 26_3M					
QPSK			16QAM		
Channel	Frequency (MHz)	99% Occupied Bandwidth (MHz)	Channel	Frequency (MHz)	99% Occupied Bandwidth (MHz)
26805	825.5	2.6899	26805	825.5	2.6918
26915	836.5	2.6957	26915	836.5	2.6913
27025	847.5	2.6996	27025	847.5	2.7048
Channel	Frequency (MHz)	26dB Bandwidth (MHz)	Channel	Frequency (MHz)	26dB Bandwidth (MHz)
26805	825.5	2.9230	26805	825.5	2.9010
26915	836.5	2.9050	26915	836.5	2.9020
27025	847.5	2.9940	27025	847.5	2.9210