



Micronet SmartCAM™

Vehicular Android Camera DVR and ADAS
(Advanced Driver Assistance System)
Hardware Guide



powered by
ANDROID

Disclaimer: Micronet reserves the right to change product specifications without prior notice

Important Notice

© 2019 Micronet Ltd. All rights reserved.

Micronet Ltd. Reserves the right to alter the equipment specifications and descriptions in this publication without prior notice. No part of this publication shall be deemed to be part of any contract or warranty unless specifically incorporated by reference into such a contract or warranty.

The information contained herein is merely descriptive in nature and does not constitute a binding offer for the sale of the product described herein.

All usage of Micronet Ltd. Logotype or trademarks is forbidden without prior written approval from Micronet Ltd.

Information in this manual is subject to change without notice.

Micronet maintains no liability or responsibility to any person or entity concerning any loss or damage arising from the information contained in this book.

Other company and brand products and service names are trademarks or registered trademarks of their respective holders, for example, Google, Android, ADB, ADT, Eclipse and Android Studio.

Please refer to Micronet's website (<http://www.micronet-inc.com>) for further information or contact us directly (<https://www.micronet-inc.com/contact/>)

Table of Contents

Table of Contents	3
Revision History	5
Safety Precautions	6
1. Introduction.....	7
Micronet SmartCAM Platform Overview	7
In the Vehicle	7
Micronet SmartCAM Models	8
Compatibility with Micronet SmartX Products	9
Shorter Development Cycles.....	9
Lower Total Cost of Ownership	9
GSD® Software Services	9
Development Tool Kit.....	10
Platform Key Feature Specifications	10
2. Micronet SmartCAM Views	11
Micronet SmartCAM Front View	11
Micronet SmartCAM Rear View	12
Micronet SmartCAM Top View	13
3. Micronet SmartCAM Functional Details	14
Platform Core	14
User Interface.....	15
Cameras	16
Sound.....	16
Connectivity	16
Battery	18
Motion Control	19
Communication Interfaces.....	19
General Purpose I/O	20
Vehicle Bus Connectivity	20
4. Micronet SmartCAM™ Models	21
Overview.....	21
ELD Mandate	21
Fix Mount Lock.....	21
LED and Buzzer.....	21
5. Standard Model	22
Overview.....	22
Functional Details.....	22
Standard Cradle Dev Cable.....	22
General Purpose I/O	25
6. Intermediate Model.....	26
Overview.....	26
Functional Details	26
Standard & Intermediate Model Dev Cable	26
General Purpose I/O	29
7. Enhanced Model	30
Overview.....	30

Platform Core	30
Functional Details	30
Enhanced Model Dev Cable	30
Vehicle Bus Connectivity	31
General Purpose I/O	34
8. Signals Map	36
Overview	36
Basic and Intermediate Signal Map	36
Standard and Intermediate Model Signal Pinout	36
9. Enhanced Signals Map	39
Overview	39
10. SmartCAM™ Installation Mechanical Installation	41
Device Installation Steps	43
Electrical Installation	43
11. Physical Characteristics	45
12. Known Issues	46
Overview	46
Access Point Configuration:	46
SD Card Format Error:	46
Battery Depletion Reboot:	46
Battery Not Charging:	46
Roadside Camera Performace:	47
Microphone Gain:	47
IR LED Brightness:	47

Revision History

Revision	Date	Change
1	September 2019	Document created

Safety Precautions

Read the following safety precautions before installation or operation.

**WARNING!****Abnormal Conditions**

Should the Micronet SmarTab become hot, start to emit smoke or a strange odor, immediately turn off the power and contact your original dealer or authorized service provider. Continued usage is dangerous and may result in fire or electric shock.

**WARNING!****Foreign Objects**

Avoid having foreign matter or objects enter into any opening of the Micronet SmarTab. This could result in fire or electric shock. Immediately turn off the power and contact your original dealer or an authorized service provider.

**WARNING!****Liquids**

Keep the device away from water, other liquids and liquid containers. Liquid entering into the device can cause fire and electric shock.

**CAUTION****LCD Screen**

Never apply heavy pressure to the Micronet SmarTab display or subject it to strong impact. Doing so may crack the screen or LCD panel glass, resulting in personal injury or major damage to the device. Should the LCD panel glass break, do not touch the liquid inside. Should liquid from the LCD panel accidentally touch a person's skin or enter a person's mouth or eyes, immediately rinse the area affected with water and contact a physician.

**CAUTION****Battery and Power Supply**

- Charge the battery only as instructed on [Charging the Battery](#) instruction.
- Immediately stop the charging while battery or device - overheating, smell, smoke, change color, distortion etc.
- Battery charging temperature can review on [Charging Temperature](#)
- Micronet SmarTab includes unremovable battery. Therefore, the Micronet SmarTab rear panel should not open for remove the battery.

**CAUTION**

Risk of explosion if battery replaced by an incorrect type. Dispose of used batteries according to the instructions.

**CAUTION**

Use careful with the earphone maybe possible excessive sound pressure from earphones and headphones can cause hearing loss.

1. Introduction

Micronet SmartCAM Platform Overview

In today's commercial Telematics industry there is a growing demand for onboard devices that not only send sensor data from the vehicle and driver environment for backend processing, but devices that also analyze, detect, and notify the driver in real-time of any potential safety risks, operational errors, and protocol violations. Events such as near-collision, tailgating, unsafe lane departures, hard braking/cornering/accelerating, stop sign violations, speeding, distracted driving, driver fatigue, and more comprise a rich dataset that is used by fleet managers to measure their drivers' skills and performance. It is also used to deploy training and education programs that result in improved fleet safety, reduced insurance claims and premiums, higher up-time, and lower maintenance costs.

The Micronet SmartCAM™ enables fleet managers to address all these safety events not only through conventional Telematic sensors such as GPS, 3D accelerometer, I/O, and CANbus, but also by providing the 'Full Picture' through a rich set of real-time, onboard video analytics and AI capabilities enabled by a dual automotive-grade camera for road and in-cabin monitoring all packaged into a single device. This saves costly installations of separate ELD device installations for Telematics, ADAS, and DashCams. It also saves upload data due to the local video analytics processing done on the device and its powerful computing platform.

With the ability to run multiple applications simultaneously, the Micronet SmartCAM™ allows Telematics Service Providers and System Integrators to extend their offering beyond their applications and provide customers with advanced 3rd party mobility and video analytics applications.

In the Vehicle

Placed on the vehicle windshield, the Micronet SmartCAM™ functions as a high-end camera and onboard Telematics computer. With integrated GPS, rear and front cameras, cellular communications, various sensors, and support for a variety of vehicle-bus and peripheral interfaces, the Micronet SmartCAM™ enables a host of Fleet Management and Video Analytics solutions such as: ADAS, Driver Fatigue, ELD/HOS, fleet tracking, driver behavior, real-time driver coaching and fuel management, remote diagnostics, DVIR, backend communications, and much more.

The Micronet SmartCAM's two cameras, together with its powerful processor and memory, allows it to run advanced algorithms required for video analysis applications like tailgate monitoring, unsafe lane departures, collision warnings, speed limit and stop sign detection, driver fatigue, distracted drivers, driver ID, and passenger counting.



With a rich set of wireless and wired interfaces – Wi-Fi hotspot, BT tethering and BLE, Bluetooth audio, NFC, Wi-Fi Direct, multiple CAN channels (including open/customizable CAN libraries), and multiple I/Os – the Micronet SmartCAM™ can function as an in-cabin hub to easily connect with other devices, sensors, and accessories. Driver notification features such as system status LEDs, warning indicators, internal speakers, and microphone are also provided for device control and driver alerting purposes.

The Micronet SmartCAM™ lets drivers remain safe, effective, and efficient with on-the-go connectivity – anytime and anywhere – using cellular communication and Wi-Fi. Its durable design withstands shocks and a range of temperatures, allowing drivers to operate freely in any environment. Installed on the windshield, the Micronet SmartCAM™ has a perfect view of the road and the cabin.

The Micronet SmartCAM™ is a superior and cost-effective solution for Video Telematics.

Micronet SmartCAM Models

Micronet has implemented the SmartCAM™ platform in three product variants: The Basic Model, an Intermediate Model, and Enhanced Model. These models include powerful computing, extended memory, GPS, Wi-Fi, Bluetooth, NFC, and more. In addition, each model supports a set of additional features:

- **Basic Model** – provides support for 2 cameras, a QC SDM450 chipset (2GB/16GB memory), and additional storage for DVR recording. This model is described in more detail in the [Basic Model](#).
- **Intermediate Model** – In addition to the Basic Model, the [Intermediate Model](#) provides 4G LTE.
- **Enhanced Model** - provides basic + enhanced key features set, described in [Enhanced Model](#) list below.

The following Table 1 distinguishes each model for their specific components:

Table 1: Micronet SmartCAM™ Models

	Basic	Intermediate	Premium (V2)
CAN BUS	X	X	J1939/J1708
Cellular	X	3G/HSPA+/4G LTE	3G/HSPA+/4G LTE
USB interface	Debug / Download	Debug / Download	Hub (OTG)
Memory RAM/Flash	2GB/16GB	2GB/16GB	2GB/16GB

Compatibility with Micronet SmartX Products

The Micronet SmartCAM™ is based on the same hardware and software platform as the Micronet SmartHub, SmarTab, and Tab 8 – Micronet’s next-generation Android On-Board-Computer. Telematics Service Providers who develop applications for Micronet’s SmartX series products can easily adjust and run those apps on the Micronet SmartCAM™ for customers who also need that as part of their solution.

Shorter Development Cycles

Powered by an open Android platform, the Micronet SmartCAM™ platform offers a comprehensive development environment for independent application programming and system integration. Because of the vast ecosystem of Android development tools and software frameworks, and a flourishing community of developers, working with Android devices has rapid development and integration cycles.

Lower Total Cost of Ownership

Designed to operate in harsh automotive field environments, the Micronet SmartCAM™ lowers the total cost of ownership by withstanding shocks, vibrations, and extreme temperatures

GSD® Software Services

Micronet’s GSD™ (Guardian System Design) is a cloud-based Software as a Service (SaaS) platform for managing mobile devices in the field.

GSD™ enables remote delta-based, over-the-air, firmware, and application updates allowing customers to keep devices relevant anywhere, anytime. It features Mobile Device Management functionality, Remote Control, and self-tests.

Administrators can proactively monitor and manage connected devices with a flexible web interface.

Introducing GSD® - Advanced software tools to manage and support mobile devices in the field.

Micronet’s new comprehensive software framework called GSD® - Guardian System Design - is a cloud-based Software-as-a-Service platform that provides advanced software tools to manage and support applications and system firmware upgrades on Micronet and third-party devices installed in the field. The GSD® enables remote over-the-air access and control of Android-based mobile devices to conduct individual or group diagnostics to support training activity.

GSD® a fully integrated software framework enabling new levels of control, support, and corporate policy compliance.

GSD® is offered on the Micronet SmartCAM™ series of rugged, automotive-grade MDTs. It enables both firmware and application software to be remotely managed, simplifies maintenance, troubleshooting,



and remote training, which significantly reduces operational costs over the lifetime of the product and substantially improves user experience and customer satisfaction.

GSD® features white-label cloud-based SaaS solutions offered as two key services:

1. Mobile Device Management and remote control.
2. Fail-safe firmware and application over-the-air updates (FOTA/OTA).

Development Tool Kit

Micronet's SmartCAM™ Development Package provides all the tools required for product evaluation, application development, quick-start, and product testing. The Developers Package contains all essential hardware and software components as described in the following sections:

Hardware

- Micronet SmartCAM™
- SmartCAM™ Basic, Intermediate, or Enhanced Model
- Wall power supply
- Main cable harness
- Mechanical and interface connection accessories
- Mounting accessories

Software

- Software Development Kit (SDK) provides a set of software tools and API documentation.
- Android demo samples for some device features, including the source code.

Documentation

- Micronet SmartCAM™ Hardware Guide
- Micronet SmartCAM™ Getting Started Guide
- Micronet SmartCAM™ OS Update Guide
- Micronet SmartCAM™ Remote Control and Display Guide

Platform Key Feature Specifications

The Micronet SmartCAM™ Tablet key feature specifications are documented in the "Micronet SmartCAM™

Datasheet" document provided with the DTK documentation.

2. Micronet SmartCAM Views

Micronet SmartCAM Front View



Figure 1: Micronet SmartCAM™ Front View

For more information about the Micronet SmartCAM™ front view see:

- [Driver \(In-Cabin\) Camera](#)
- [System, Driver, and IR LEDs](#)
- [Multipurpose Button](#)
- [Locking Screw](#)
- [Mounting Arm / Sunshield](#)
- [Custom Labeling](#)
- [NFC Proximity Reader](#)
- [Speaker](#)

带格式的: 正文

Micronet SmartCAM Rear View



Figure 2: Micronet SmartCAM™ Rear View

For more information about the Micronet SmartCAM™ rearview see:

- [Memory Card](#)
- [MicroSIM Card Slot](#)
- [Road-Facing Camera](#)

Micronet SmartCAM Top View



Figure 2: Micronet SmartCAM™ Top View

For more information about the Micronet SmartCAM™ rear-view see:

- [Installation Cable](#)
- [USB Type-C Port](#)

批注 [BS1]: Probably need a different picture

3. Micronet SmartCAM Functional Details

Platform Core

Operating System

The Micronet SmartCAM™ runs on Google™ Android™ 9.0 Pie.

Google and Android are trademarks of Google LLC.

ELD Compliance

The Micronet SmartCAM™ system boot time is ~40 seconds. The ELD requirement is up to 1 minute. Please refer to the [ELD Mandate](#) for more information.

Application Development Environment

The Micronet SmartCAM™ supports any open source IDE. Micronet recommends using Android Studio.

Micronet's Development Toolkit (DTK) includes the following components:

- Micronet SDK
- Application samples that demonstrate Micronet's proprietary API
- Device management and upload tools
- Development accessories
- Documentation

For more details about the development infrastructure, product tools, and DTK contents, please refer to the "Micronet SmartCAM™ Getting Started" Guide.

Processor

- Qualcomm Snapdragon™ 450 – 2 GHz Octa Core
- High-performance Superscalar 8x ARM® Cortex™ A-53

RAM

2 GB LPDDR3 RAM memory

Flash Memory

16 GB eMMC

Memory Card

The Micronet SmartCAM™ has a MicroSD card slot that supports cards formatted as ext4 and Fat32 up to 128 GB. The MicroSD card slot is located on the road-facing panel behind the mountable sun-shield.

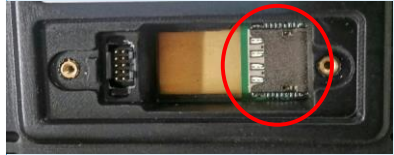

Figure 3: Micronet SmartCAM™ Memory Card Slot

批注 [BS2]: Need this picture, don't have a SmartCAM™

Watchdog

To monitor mission-critical processes, the platform provides an intelligent watchdog mechanism. The watchdog provides various capabilities for temperature control and restarts if the system hangs. The Android OS provides a software level watchdog mechanism by the "Application Manager" to control application stability.

User Interface

Hard Keys

The Micronet SmartCAM™ has one key on the side, which is configurable for a variety of purposes.

NFC Proximity

The Micronet SmartCAM™ provides an NXP PN547 NFC (Near Field Communication) proximity reader. When the Micronet SmartCAM™ is docked in a cradle, it has an NFC slot for reading the NFC proximity card by the Micronet SmartCAM™ tablet. It supports 13.56MHz cards and complies with IS15693 and IS18000-3 standards.

NFC Antenna

The NFC antenna is located on the Micronet SmartCAM™ in-cabin facing panel:



Figure 4: SmartCAM™ NFC Proximity Reader Area



System, Driver, and IR LEDs

The Micronet SmartCAM™ has two LEDs, one tri-color system status LED (located on the left side), and another driver feedback LED located at the top of the in-cabin facing panel. The Micronet SmartCAM™ also has a configurable Infrared (IR) LED ring which can be used for driver detection via heat sensing in addition to the light-sensing LED for similar functionality.

Multipurpose Button

The Micronet SmartCAM™ has a multipurpose button that can be configured to power ON/OFF the device or other customer functions.

Cameras

Road-Facing Camera

The Micronet SmartCAM™ has a 2 MP, Full HD (1080p) autofocus road-facing camera with autofocus, which has low light sensitivity, 120 dB of dynamic range in HDR mode, 110° Field of Vision (FOV), and runs at 30 frames per second (FPS).

Cabin-Facing Camera

The Micronet SmartCAM™ has a 2 MP, Full HD (1080p) autofocus cabin-facing camera with Near-Infrared Sensitivity and IR LEDs, very wide dynamic range (for multiple exposures), a 140° FOV, and run at 60 FPS.

Sound

Internal Speaker

The Micronet SmartCAM™ has a 1-Watt integrated speaker located on the in-cabin facing panel.

Microphone

The platform also has a highly sensitive microphone located at the bottom of the right panel.

批注 [BS3]: Couldn't find where the microphone is located.

Connectivity

Wireless LAN

The Micronet SmartCAM™ provides a dual-mode Wireless Local Area Network (IEEE 802.11 b/g/n/ac) 2.4 or 5 GHz module.

Wireless LAN communication is especially suited for high-speed data transfer over the air when a hotspot infrastructure exists. For applications that require large data transactions, wireless LAN is the most economical way to implement the solution.



The WLAN module provides a 2.4 or 5 GHz IEEE 802.11 b/g/n/ac Ethernet adapter with a high rate of wireless speed up to 150Mbps. The module supports WPA / WPA2 encryption, Wi-Fi Direct, and Hotspot Tethering for up to 10 connected users simultaneously.

Bluetooth 4

The Micronet SmartCAM™ provides a Bluetooth 4.1 BLE module for voice and data.

Cellular Modem

The Micronet SmartCAM™ provides two hardware options of the cellular modem:

- **3.5G GSM** - B8/850/900 and B3/1800/1900, WCDMA 1/2/4/5/8 (DC-HSPA+) B1/2100 and B8/900 for Europe.
- **4G LTE** – North America bands, AT&T and T-Mobile B2 1900MHz, B4 AWS1700MHz, B5 850MHz, B12/B13 700MHz. The modem supports all the following LTE FDD bands on Table 2 below: 1, 2, 3, 4, 5, 7, 8, 12, 13, 17, 20, 28.

Table 2: FDD LTE Bands & Frequencies

FDD LTE BANDS & FREQUENCIES					
LTE BAND #	UPLINK (MHZ)	DOWNLINK (MHZ)	BANDWIDTH (MHZ)	DUPLEX SPACING (MHZ)	BAND GAP (MHZ)
1	1920 - 1980	2110 - 2170	60	190	130
2	1850 - 1910	1930 - 1990	60	80	20
3	1710 - 1785	1805 - 1880	75	95	20
4	1710 - 1755	2110 - 2155	45	400	355
5	824 - 849	869 - 894	25	45	20
6	830 - 840	875 - 885	10	35	25
7	2500 - 2570	2620 - 2690	70	120	50
8	880 - 915	925 - 960	35	45	10
9	1749.9 - 1784.9	1844.9 - 1879.9	35	95	60
10	1710 - 1770	2110 - 2170	60	400	340
11	1427.9 - 1452.9	1475.9 - 1500.9	20	48	28
12	698 - 716	728 - 746	18	30	12
13	777 - 787	746 - 756	10	-31	41
14	788 - 798	758 - 768	10	-30	40
15	1900 - 1920	2600 - 2620	20	700	680
16	2010 - 2025	2585 - 2600	15	575	560
17	704 - 716	734 - 746	12	30	18
18	815 - 830	860 - 875	15	45	30
19	830 - 845	875 - 890	15	45	30
20	832 - 862	791 - 821	30	-41	71
21	1447.9 - 1462.9	1495.5 - 1510.9	15	48	33
22	3410 - 3500	3510 - 3600	90	100	10
23	2000 - 2020	2180 - 2200	20	180	160
24	1625.5 - 1660.5	1525 - 1559	34	-101.5	135.5
25	1850 - 1915	1930 - 1995	65	80	15
26	814 - 849	859 - 894	30 / 40		10
27	807 - 824	852 - 869	17	45	28
28	703 - 748	758 - 803	45	55	10

带格式的: 正文, 缩进: 左侧: 0 厘米

MicroSIM Card Slot

The LTE/GSM modem requires a MicroSIM card connection. The MicroSIM card slot is located on the road-facing panel behind the mountable sun-shield.

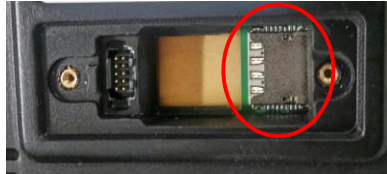

Figure 5: Micronet SmartCAM™ SIM Card Slot

Cellular Antennas

The Micronet SmartCAM™ has two Main and Diversity internal integrated antennas.

GPS Receiver

The Micronet SmartCAM™ provides a highly sensitive GPS receiver which supports 50 different channels, as well as NMEA0183 standard sentences, AGPS, GPS, and GLONASS satellites.

GPS Antennas

The Micronet SmartCAM™ has an integrated Ceramic internal antenna.

Battery

Capacity

The Micronet SmartCAM™ includes a Non-removable Li-Polymer 160 – 350 mAh internal battery for ordered shutdown upon loss of power from the vehicle's battery.

Charging the Battery

The Micronet SmartCAM™ provides fast charging through its USB OTG connector on the left panel and through the cradle, which is connected permanently to the vehicle's battery. The also charges the through the POGO pins at 5V DC power.

Charging Mechanism

The Micronet SmartCAM™ provides a smart charging mechanism. When connected to a power source (e.g. wall mount power supply, PC USB, SmartCAM™ cradle), the battery is charged and also powers the CPU in parallel. On reaching temperatures above 45°C, the internal battery disconnects from the

power source. After disconnecting, the power source from the SmartCAM™ battery reconnects and provides power to CPU. This mechanism prolongs the life of the battery.

Charging Temperature

The Micronet SmartCAM™ battery charging temperature is as follows:

- Battery operating temperature: 0°C to ~ +70°C, 45~85% RH
- Charge: 0°C to ~ +45°C, 45~85% RH



The operating system blocks charging when the temperature is over the defined (45°C). By this function the device is protected even while in operation.

Motion Control

The Micronet SmartCAM™ provides an accelerometer, compass, and gyroscope module. The accelerometer is an electromechanical device used to measure acceleration forces. Such forces may be static like the continuous force of gravity or, as is the case with many mobile devices, dynamic to sense movement or vibrations.

Communication Interfaces

Serial Communication

The Micronet SmartCAM™ provides serial communication ports with both the standard and enhanced models. Each model includes a single serial port for communication and a serial debug port for debugging.

Please refer to the detailed description of the Standard, Intermediate, and Enhanced [Serial Communication](#).

USB Communication

The Micronet SmartCAM™ supports a USB Type-C interface; it located on the [Micronet SmartCAM™ Top View](#) of the device.

The SmartCAM™ standard supports USB Client interface for ADB communication. The enhanced support two USB communication ports, one USB Host and one USB Client device. Please refer to the detailed description of the standard [USB Communication](#) and of the enhanced [USB Communication](#).



NOTE:

The product can connect only to a USB 3.0 or 2.0 interface (no superspeed).

General Purpose I/O

Input lines

The Micronet SmartCAM™ supports general-purpose input lines for ignition sense, automotive digital lines, A2D, and other functions.

The standard model includes one input line for ignition sense. The enhanced model includes one input line for ignition sense and seven general-purpose input lines. Please refer to the detailed description of the standard [Automotive Input](#) and for the enhanced [Analog and Digital Input lines](#).

Output Lines

The Micronet SmartCAM™ supports general-purpose Open-Collector output lines for various functions, through the enhanced only. Please refer to the detailed description of the enhanced [Open Collector Output lines](#).

Vehicle Bus Connectivity

SAE J1939 CANBus

The Micronet SmartCAM™ provides two SAE J1939 CANBus ports through its enhanced model that enables the connection of a variety of vehicle peripherals, such as the vehicle's computer, vehicle's sensors, and so on. Please refer to the detailed description of the enhanced [SAE J1939 CANBus](#).

Single Wire CANBus

The Micronet SmartCAM™ provides a single wire CANBus port through its enhanced model. Please refer to the detailed description of the enhanced [Single Wire CAN](#).

SAE J1708

The Micronet SmartCAM™ provides a J1708 port through its enhanced model. Please refer to the detailed description of the enhanced [SAE J1708](#). If you connect to the J1708 port, you can only connect to one additional J1939 port.

4. Micronet SmartCAM™ Models

Overview

The Micronet SmartCAM™ Platform offers various types of vehicle, allowing durable, protected Device mounting and electronic connection in the vehicle. Compatible with a standard "RAM" mounting arm, the supports easy installation and adjustable device position for convenience of use in an agitated vehicle cabin environment.

There are three models of the Micronet SmartCAM™ available: the Intermediate Model and Enhanced Model – each supporting various features and connection interfaces.

A Micronet SmartCAM™ Device "Lock" option is available on both Standard and Enhanced models to support the "Fixed-Mounted" solution operation only, by preventing of the Device removal. For more details, refer to Fix Mount Lock.

ELD Mandate

The ELD (Electronic Logging Device) Mandate in the USA requires electronic devices to be always connected to the telematics vehicle. Since the Micronet SmartCAM™ is a portable device and all telematics information is stored on the device, the is equipped with an LED and Buzzer to alert when the device not docked while the vehicle's ignition switch is ON. This LED and Buzzer WARN the driver and reminds him or her to dock the device in the cradle.

Fix Mount Lock

The Micronet SmartCAM™ has a locking mechanism option to permanently install the device and prevent tampering. It is an option when a fix mount installation is required. The fix mount lock parts include one screw to prevent pushing the latch and an adhesive cover to hide the screw.

LED and Buzzer

The LED and buzzer are used to alert the driver that the Micronet SmartCAM™ is not locked in place. This alert is enabled by default. The cradle's MCU firmware provides an API to disable both the LED and buzzer if required.

5. Standard Model Overview

The Standard (Basic) model of the SmartCAM™ includes a basic set of interfaces including power, ground, ignition, serial communication as well as serial debug ports, and GPIOs.

Functional Details

The Micronet SmartCAM™ standard provides the following interfaces:

- 12V/24V line to charge the Micronet SmartCAM™ battery
- Digital input signal for ignition switch control
- A single automotive input and an open-collector output
- USB Type-C for ADB connection
- Serial communication and serial debug ports

Standard Cradle Dev Cable

The Micronet SmartTab 8 standard cradle development cable, shown in figure 6 below, exposes power, ignition, USB Type-C, a serial communication line and a serial debug line, and two GPIOs.

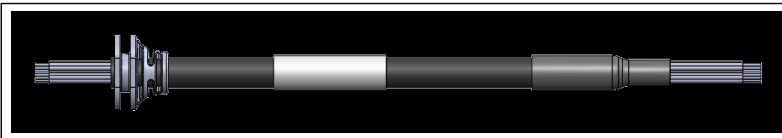

Figure 6: Micronet SmartCAM Standard & Intermediate Model Cable Harness GCAB516.

The pinout for P1, P2, and P3 is displayed in the standard cradle pinout in Figure 7 below:

	SIGNAL	COLOR	AWG	TWISTED	SHIELD
1	POWER_INPUT	RED	24		
2	POWER_GND	BLACK	24		
3	IGNITION	YELLOW	24		
4	GND	BLACK/RED	24		
5	GP_IN	BROWN	24		
6	GP_OUT	PURPLE	24		
7	RS232_TX	RESEDA	24		
8	RS232_TX_DBG	BLUE	24		
9	RS232_RX_DBG	PINK	24		
10	GND	BLACK/WHITE	24		
11	RS232_RX	WHITE/RED	24		
12	GP_IO	ORANGE	24		

Figure 7: Micronet SmartCAM Standard & Intermediate Model Cable Pinout

Power Connector

The power connector (marked as **P1**) is a 4-pin, 2 row MicroFit 3.0 series Molex male connector and the pinout for power and ignition lines are described in figure 8 below:



Figure 8: Molex 4-Pin Male Connector

Power Consumption

Table 3: Micronet SmartCAM™ Standard Current Consumption

Micronet SmartCAM™ Standard Current	
12V	24V
3mA	3mA

批注 [BS4]: Need this info, we don't have a SmartCAM™

Serial Communication

Serial Port 1 (COM1)

The Micronet SmartCAM™ Intermediate Model supports an (EIA) RS-232 level serial communication on its port. It provides TX and RX signals at 300 to 115,200bps.

Debug Serial Port (COM7)

The Intermediate Model also supports an EIA-RS232 level serial communication port for Co-Processor debugging purposes. The port supports a baud rate of 300 to 115,200bps, and provides the TX and RX signals only.

USB Communication

USB TYPE-C

The standard cradle supports a USB Type-C port (not part of the external cable). It supports DFP (Downstream Facing Port) for device connection as UFP (Upstream Facing Port) for connecting to a USB HUB, Desktop, ADB for debugging, device configuration, and application development. It also supports dual-role behavior according to USB3.x standard for DRP (Dual Role Port).

You can use the USB through the Micronet SmartTab 8 USB Type-C connector on the top of the device next to the installation cable.

批注 [VZ5]: see above

批注 [BS6]: Need picture



Note:

OS Burn using Fastboot only works through the Micronet SmartCAM™ USB Type-C plug.



Automotive Input

The Micronet SmartCAM™ standard provides one automotive digital input for ignition.



The Ignition input line powers ON the Micronet SmartCAM™ from shutdown and suspend states. For proper power management implementation, the ignition input line should connect to the vehicle's ignition switch, and power to the should connect to the vehicle's battery. See [Electrical Installation](#) for more information.

Table 4: Ignition line States, Electrical Parameters

Input State	Typical	Minimum	Maximum
Low	0V	-30V	+6V
High	12V-24V	+7V	+30V

General Purpose I/O

Analog and Digital Input lines

In addition to the ignition line, the SmartCAM™ provides one automotive input line (0-32V). This input lines can be read as digital (state 0 or 1) or analog (voltage level) lines. It also provides a configurable GPIO for input/output. For more information about these interface signals please see the digital output signals map [Pinout by Functionality](#).

Digital input

IGN (automotive voltage state) is for monitoring the ignition switch signal. The other input line can be used for any purpose, like sensing door opening, sensing bus amber lights, etc.

Analog Input

GPIO can be treat as analog input to monitor the value range of compatible vehicle sensors, such as an analog fuel gauge. The supported voltage range is from 0V to 30V.

Open Collector Output

The SmartCAM™ also provides one O.C output line for external peripheral control. For more information about these interface signals please see the digital output signals map [Pinout by Functionality](#).

6. Intermediate Model

Overview

The Intermediate model of the SmartCAM™ has all of the same functionality and pinouts as the Standard model; however, it also has 4G LTE cellular data enabled for backend server updates and statistics.

批注 [B57]: Need this info reviewed

Functional Details

The Micronet SmartCAM™ intermediate model provides the following interfaces:

- 12V/24V line to charge the Micronet SmartCAM™ battery
- Digital input signal for ignition switch control
- An automotive input, and an open-collector output
- USB Type-C for ADB connection
- Serial communication port and serial debug port

Standard & Intermediate Model Dev Cable

The Micronet SmartCAM standard and Intermediate development cable, shown in figure 9 below, exposes power, ignition, a serial communication line and a serial debug line, and two GPIOs:

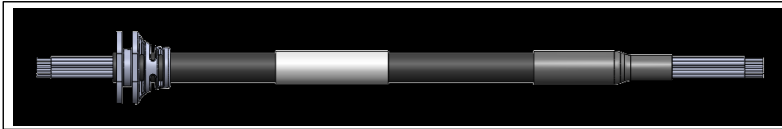

Figure 9: Micronet SmartCAM Standard & Intermediate Model Cable Harness GCAB516.

The pinout for P1, P2, and P3 is displayed in the standard cradle pinout in Figure 10 below:

	SIGNAL	COLOR	AWG	TWISTED	SHIELD
1	POWER_INPUT	RED	24		
2	POWER_GND	BLACK	24		
3	IGNITION	YELLOW	24		
4	GND	BLACK/RED	24		
5	GP_IN	BROWN	24		
6	GP_OUT	PURPLE	24		
7	RS232_TX	RESEDA	24		
8	RS232_TX_DBG	BLUE	24		
9	RS232_RX_DBG	PINK	24		
10	GND	BLACK/WHITE	24		
11	RS232_RX	WHITE/RED	24		
12	GP_IO	ORANGE	24		

Figure 10: Micronet SmartCAM Standard & Intermediate Model Cable Pinout

Power Connector

The power connector (marked as **P1**) is a 4-pin, 2 row MicroFit 3.0 series Molex male connector and the pinout for power and ignition lines are described in figure 11 below:



Figure 11: Molex 4-Pin Male Connector

Power Consumption

Table 5: Micronet SmartCAM™ Intermediate Current Consumption

Micronet SmartCAM™ Intermediate Current Consumption	
12V	24V
~200mA	3mA

批注 [B58]: Need this info, we don't have a SmartCAM™

Serial Communication

The intermediate model similarly supports a serial communication port for external device connection, and a debug port connected to the MCU Co-Processor. These ports support various hardware and software flow

control functions. For more information about the interface signals, please see the signal map [Pinout by Functionality](#).

Serial Port 1 (COM1)

The intermediate model supports an (EIA) RS-232 level serial communication on its port. It provides TX and RX signals at 300 up to 115,200bps. The serial port provides one pair of communication control handshake CTS/RTS signals.

Debug Serial Port (COM7)

The intermediate model supports EIA-RS232 level serial communication port for Co-Processor debugging purposes. The port supports a baud rate of 300 to 115,200bps, and provides the TX and RX signals only.

USB Communication

USB TYPE-C

The intermediate model supports a USB Type-C port (not part of the external cable). It supports DFP (Downstream Facing Port) for device connection as UFP (Upstream Facing Port) for connecting to a USB HUB, Desktop, ADB for debugging, device configuration, and application development. It also supports dual-role behavior according to USB3.x standard for DRP (Dual Role Port).

You can use the USB through the Micronet SmartTab 8 USB Type-C connector on the top of the device next to the installation cable.

批注 [VZ9]: see above



Note:

OS Burn using Fastboot works through the Micronet SmartCAM™ USB Type-C plug.



批注 [BS10]: Need picture

Automotive Input

The Micronet SmartCAM™ standard provides one automotive digital input for ignition.



The Ignition input line powers ON the Micronet SmartCAM™ from shutdown and suspend states. For proper power management implementation, the ignition input line should connect to the vehicle's ignition switch, and power to the should connect to the vehicle's battery. See [Electrical Installation](#) for more information.

Table 6: Ignition line States, Electrical Parameters

Input State	Typical	Minimum	Maximum
Low	0V	-30V	+6V
High	12V-24V	+7V	+30V

General Purpose I/O

Analog and Digital Input lines

In addition to the ignition line, the SmartCAM™ provides one automotive input line (0-32V). This input lines can be read as digital (state 0 or 1) or analog (voltage level) lines. It also provides a configurable GPIO for input/output. For more information about these interface signals please see the digital output signals map [Pinout by Functionality](#).

Digital input

IGN (automotive voltage state) is for monitoring the ignition switch signal. The other input line can be used for any purpose, like sensing door opening, sensing bus amber lights, etc.

Analog Input

GPIO can be treat as analog input to monitor the value range of compatible vehicle sensors, such as an analog fuel gauge. The supported voltage range is from 0V to 30V.

Open Collector Output

The SmartCAM™ also provides one O.C output line for external peripheral control. For more information about these interface signals please see the digital output signals map [Pinout by Functionality](#).

7. Enhanced Model

Overview

The Enhanced Model of the Micronet SmartCAM™ similarly supports a serial communication and serial debug port, control I/O signals, and in addition it offers vehicle BUS interface connections that a developer can use to implement his or her ADAS and Telematics Solution.

Platform Core

MCU Processor

The enhanced MCU CPU consists of the Freescale K20_120 MQX RTOS.

Functional Details

The Micronet SmartCAM™ enhanced model provides the following interfaces:

- 12V/24V for charging the Micronet SmartCAM™ battery
- Digital input signal for ignition switch control
- One general-purpose input line, A2D, or Automotive digital input
- One general-purpose open-collector output line
- A serial communication port and a serial debug port
- Two J1939 CAN interfaces
- Single Wire CAN
- J1708 interface

Enhanced Model Dev Cable

In addition to the standard model, the Micronet SmartCAM enhanced model also provides two J1939 CAN interfaces, a Single Wire CAN line, and a J1708 line. These added interfaces are shown below in figures 12 and 13 on the enhanced model development cable drawing and pinout:

NOTE: The Micronet SmartCAM DTK cable (P/N: GCAB618) includes MicroFit 3.0 Molex connectors crimped to the ends of the wires, but the Standard, Intermediate, and Enhanced model Production cables all come with open-ended wires.

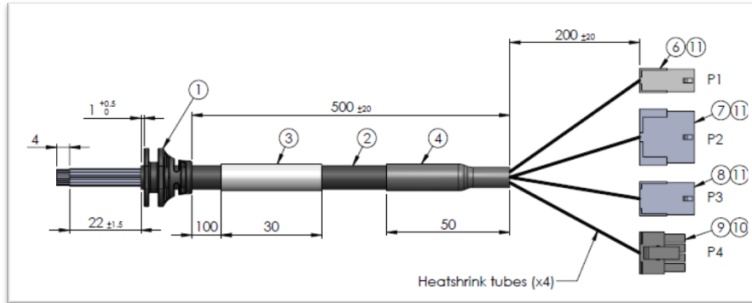

Figure 12: Micronet SmartCAM Enhanced Model Cable Drawing (P/N: GCAB618).

The pinouts for P2 – P6 are displayed in the enhanced cradle pinout in Figure 13 below:

SIGNAL	COLOR	AWG	TWISTED	P1	P2	P3	P4
POWER_INPUT	RED	24		4	8		
POWER_GND	BLACK	24		3	7		
IGNITION	YELLOW	24		1	10		
CAN1_P	GRAY	24	T1		1		
CAN1_N	WHITE	24	T1		2		
J1708_P/CAN2_P	RED/BLACK	24	T2		3		
J1708_N/CAN2_N	GREEN	24	T2		4		
GP_OUT	ORANGE	24				2	
RS232_TX	RESEDA	24				4	
RS232_TX_DBG	BLUE	24					2
RS232_RX_DBG	PINK	24					1
GND	BLACK	24				6	3
RS232_RX	ORANGE	24				5	
GP_IN	WHITE/BLACK	24				1	
GP_IO	BROWN	24				3	
SWC	PURPLE	24			9		

Figure 13: Micronet SmartCAM Enhanced Model Cable Pinout

Vehicle Bus Connectivity

CANbus Connector

The CANbus connector (marked as **P2**) is a 10-pin, 2 row MicroFit 3.0 series Molex male connector, shown in figure 14 below, which provides CAN 1 HIGH/LOW, CAN 2 HIGH/LOW, J1708, and Single Wire CAN:



Figure 14: Molex 10-Pin Male Connector

SAE J1939 CANBus

The SmartCAM™ enhanced model provides two SAE J1939 CANBus ports that enable the connection of a variety of vehicle peripherals, such as the vehicle's computer, vehicle's sensors and so on.

The provided CANBus V2.0B (a 1 Mbps port) supports the following functionality:

- 0 - 8-byte length in the data field
- Standard and extended data and remote frames
- Two receive buffers with prioritized message storage
- Six 29-bit filters
- Two 29-bit masks
- Three transmit buffers with prioritization and abort features

Single Wire CAN

The SmartCAM™ enhanced provides SAE J2411 single wire for CAN network applications with low requirements regarding bit rate and bus length. The communication takes place via just one bus line with a nominal data rate of 33,3 Kbit/s (83,3 Kbit/s in high-speed mode for diagnostics).

SAE J1708

The SmartCAM™ enhanced provides SAE J1708 port. The SAE J1708 is a standard used for serial communications between ECUs on a heavy-duty vehicle and between a computer and the vehicle. With respect to Open System Interconnection model (OSI), J1708 defines the physical layer. If connected to the J1708 port only one other J1939 port will be available.

Serial Communication

The enhanced model similarly supports a serial communication ports for external device connections, and a debug port connected to the MCU Co-Processor. These ports support various hardware and software flow

control functions. For more information about the interface signals, please see the signal map [Pinout by Functionality](#).

Serial Port 1 (COM1)

The enhanced model supports an (EIA) RS-232 level serial communication on its port. It provides TX and RX signals at 300 up to 115,200bps. The serial port provides one pair of communication control handshake CTS/RTS signals.

Debug Serial Port (COM7)

The enhanced model supports EIA-RS232 level serial communication port for Co-Processor debugging purposes. The port supports a baud rate of 300 to 115,200bps, and provides the TX and RX signals only.

Serial Connector

The Micronet SmartCAM enhanced model serial connector (**P3**) is a 6-pin, 2 row MicroFit 3.0 series Molex male connector, and contains GPI1/GPO1, RS232_TX/RS232_RX, and RS232_TX_DBG/RS232_RX_DBG. The serial communication connector is shown in figure 15 below:



Figure 15: Molex 6-Pin Male Connector

Power Consumption

Below in Table 7 is the current consumption of the Enhanced model of the Micronet SmartCAM:

Table 7: Micronet SmartCAM™ Enhanced Current Consumption

Micronet SmartCAM™ Enhanced Current Consumption	
12V	24V
5mA	4mA

批注 [BS11]: Need this info, we don't have a SmartCAM™

USB Communication

USB HOST

The enhanced model is a USB HOST and Client. The USB Host interface supports the following profiles:

- USB Standard HID
- USB Printer (PCL)
- USB Storage USB CLIENT

The USB Client interface supports Android ADB for application development and device management.

The USB Client port provides Android's ADB connectivity and supports:

- Device configuration
- Management tools
- Application development
- Debugging caution

Use the USB Client through the Micronet SmartCAM™ USB Type-C connector on the top of the device.



Note:

OS Burn using Fastboot only works through the Micronet SmartCAM™ USB Type-C plug.



批注 [BS12]: Need this section reviewed

批注 [BS13]: Need picture

General Purpose I/O

Analog and Digital Input lines

The SmartCAM™ similarly provides one automotive input line (0-32V) through its enhanced model in addition to the ignition line. The input line can be read as digital (state 0 or 1) or analog (voltage level) lines.

Digital Input

IGN (automotive voltage state) is for monitoring the ignition switch signal. The other input line can be used for any purpose, like sensing door opening, sensing bus amber lights, etc.



The IGN line powers on the device from a shutdown state. For proper power management, the input should be connected to the vehicle's ignition switch.

Analog Inputs

GPIO can be treated as analog input to monitor the value range of compatible vehicle sensors, such as an analog fuel gauge. The supported voltage range is from 0V to 30V.

Open Collector Output lines

The SmartCAM™ similarly provides one O.C output lines through its enhanced model for external peripheral control. For more information about these interface signals please see the digital output signals map [Pinout by Functionality](#).

Customized Labeling

Micronet provides the option to attach a customized label based on your specifications. To enable rebranding the product, Micronet will provide graphic files and size specifications. This is subject to an additional charge per unit, based on the quantity ordered.



Figures 16, 17: Customized Front & Back Panel Labels

8. Signals Map

Overview

This chapter describes the Micronet SmartCAM™ standard and enhanced signal interfaces.

Basic and Intermediate Signal Map

The Micronet SmartCAM™ Basic Model has the following interfaces on its main cable harness which are soldered directly to the PCB:

- Power Line
- Ground Line
- Digital Input Line
- Open Collector Output
- USB Type-C connector cable to be connected on the computer USB Host connector
- Serial Port and Debug Port with TX, RX, GND signals, baud rate 300-115200bps

The following abbreviations are used:

- I - Input signal
- O - Output signal
- B - Bus signal
- V - Voltage signal
- G - Ground
- P - Positive
- N - Negative

Standard and Intermediate Model Signal Pinout Pinout by Pin Number

The following table lists the 12 Basic and Intermediate Model signals by pin number:

Table 8: Standard and Intermediate Model Signal Map (by Pin Number)

Pin	Signal	Type	Function	Specifications												
1	POWER_INPUT	V	Input Power 12V/24V	Typical – 12V/24V - Minimum continues – 6V (5V for up to 40ms according to ISO7637) - Maximum continues – 32V												
2	POWER_GND	G	Ground													
3	Ignition Input	A	A2D Input Ignition switch	<table border="0"> <tr> <td></td> <td>Typical</td> <td>Min</td> <td>Max</td> </tr> <tr> <td>Input Low: VIL</td> <td>0V</td> <td>-30V</td> <td>6V</td> </tr> <tr> <td>Input High: VIH</td> <td>12V-24V</td> <td>+8V</td> <td>+32V</td> </tr> </table>		Typical	Min	Max	Input Low: VIL	0V	-30V	6V	Input High: VIH	12V-24V	+8V	+32V
	Typical	Min	Max													
Input Low: VIL	0V	-30V	6V													
Input High: VIH	12V-24V	+8V	+32V													
4	GND	G	Ground													
5	Automotive Input	I		<table border="0"> <tr> <td></td> <td>Typical</td> <td>Min</td> <td>Max</td> </tr> <tr> <td>Input Low: VIL</td> <td>0V</td> <td>-30V</td> <td>6V</td> </tr> <tr> <td>Input High: VIH</td> <td>12V-24V</td> <td>+8V</td> <td>+30V</td> </tr> </table> 0V-30V max, 12k OHM		Typical	Min	Max	Input Low: VIL	0V	-30V	6V	Input High: VIH	12V-24V	+8V	+30V
	Typical	Min	Max													
Input Low: VIL	0V	-30V	6V													
Input High: VIH	12V-24V	+8V	+30V													
6	O.C. Output	O	Open Collector Output	Max. switchable current = 300mA Max. switchable voltage = +VIN Max. saturation voltage = 0.6V												
7	RS232_TX	O	Transmit Data (COM1)	EIA-RS232 Level												
8	RS232_TX_DBG	O	Transmit Data DBG	MCU Debug port EIA-RS232 level												
9	RS232_RX_DBG	I	Receive Data DBG	MCU Debug Port EIA-RS232 level												
10	GND	G	Ground													
11	RS232_RX	I	Receive Data (COM1)	EIA-RS232 Level												
12	GP I/O	I/O	General-Purpose	Configurable General-Purpose Input / Output												

Pinout by Functionality

The following table lists the 12 Basic and Intermediate Model signals by functionality:

Table 9: Standard and Intermediate Model Signal Map (by functionality)

Pin	Signal	Type	Function	Specifications												
1	POWER_INPUT	V	Input Power 12V/24V	Typical – 12V/24V - Minimum continues – 6V (5V for up to 40ms according to ISO7637) Maximum continues – 32V -												
2	POWER_GND	G	Ground													
3	Ignition Input	A	A2D Input Ignition switch	<table border="0"> <tr> <td></td> <td>Typical</td> <td>Min</td> <td>Max</td> </tr> <tr> <td>Input Low: VIL</td> <td>0V</td> <td>-30V</td> <td>6V</td> </tr> <tr> <td>Input High: VIH</td> <td>12V-24V</td> <td>+8V</td> <td>+32V</td> </tr> </table>		Typical	Min	Max	Input Low: VIL	0V	-30V	6V	Input High: VIH	12V-24V	+8V	+32V
	Typical	Min	Max													
Input Low: VIL	0V	-30V	6V													
Input High: VIH	12V-24V	+8V	+32V													
4	GND	G	Ground													
5	Automotive Input	I		<table border="0"> <tr> <td></td> <td>Typical</td> <td>Min</td> <td>Max</td> </tr> <tr> <td>Input Low: VIL</td> <td>0V</td> <td>-30V</td> <td>6V</td> </tr> <tr> <td>Input High: VIH</td> <td>12V-24V</td> <td>+8V</td> <td>+30V</td> </tr> </table> 0V-30V max, 12k OHM		Typical	Min	Max	Input Low: VIL	0V	-30V	6V	Input High: VIH	12V-24V	+8V	+30V
	Typical	Min	Max													
Input Low: VIL	0V	-30V	6V													
Input High: VIH	12V-24V	+8V	+30V													
6	O.C. Output	O	Open Collector Output	Max. switchable current = 300mA Max. switchable voltage = +VIN Max. saturation voltage = 0.6V												
7	RS232_TX	O	Transmit Data (COM1)	EIA-RS232 Level												
8	RS232_TX_DBG	O	Transmit Data DBG	MCU Debug port EIA-RS232 level												
9	RS232_RX_DBG	I	Receive Data DBG	MCU Debug Port EIA-RS232 level												
10	GND	G	Ground													
11	RS232_RX	I	Receive Data (COM1)	EIA-RS232 Level												
12	GP I/O	I/O	General-Purpose	Configurable General-Purpose Input / Output												

9. Enhanced Signals Map

Overview

The SmartCAM™ enhanced model has the following interfaces found on its main cable harness which is soldered directly to the PCB:

Pinout by Pin Number

The following table lists the 16 enhanced model signals by pin number.

Table 10: Main Connector Signal Map (by pin number)

Pin	Signal	Type	Function	Specifications												
1	POWER_INPUT	V	Input Power 12V/24V	Typical – 12V/24V - Minimum continues – 6V (5V for up to 40ms according to ISO7637) Maximum continues – 32V												
2	POWER_GND	G	Ground													
3	Ignition Input	A	A2D Input Ignition switch	<table border="0"> <tr> <td></td> <td>Typical</td> <td>Min</td> <td>Max</td> </tr> <tr> <td>Input Low: VIL</td> <td>0V</td> <td>-30V</td> <td>6V</td> </tr> <tr> <td>Input High: VIH</td> <td>12V-24V</td> <td>+8V</td> <td>+32V</td> </tr> </table>		Typical	Min	Max	Input Low: VIL	0V	-30V	6V	Input High: VIH	12V-24V	+8V	+32V
	Typical	Min	Max													
Input Low: VIL	0V	-30V	6V													
Input High: VIH	12V-24V	+8V	+32V													
4	CAN 1 H	I/O	CAN 1 High Signal	Twisted Pair												
5	CAN 1 L	I/O	CAN 1 Low Signal	Twisted Pair												
6	J1708+ or CAN 2 H	I/O	J1708 Positive or CAN 2 High Signal	Twisted Pair												
7	J1708- or CAN 2 L	I/O	J1708 Negative or CAN 2 Low Signal	Twisted Pair												
8	O.C. Output	O	Open Collector Output 1	Max. switchable current = 300mA Max. switchable voltage = +VIN Max. saturation voltage = 0.6V												
9	RS232_TX1	I	Transmit Data (COM1)	EIA-RS232 level												
10	RS232_TX_DBG	O	Transmit Data DBG	MCU Debug port EIA-RS232 level												
11	RS232_RX_DBG	I	Receive Data DBG	MCU Debug Port EIA-RS232 level												
12	GND	G	Ground													
13	RS232_RX1	I	Receive Data (COM1)	EIA-RS232 level												
14	Automotive Input	I	Digital Input 1	<table border="0"> <tr> <td></td> <td>Typical</td> <td>Min</td> <td>Max</td> </tr> <tr> <td>Input Low: VIL</td> <td>0V</td> <td>-30V</td> <td>6V</td> </tr> <tr> <td>Input High: VIH</td> <td>12V-24V</td> <td>+8V</td> <td>+30V</td> </tr> </table> 0V-30V max, 12k OHM		Typical	Min	Max	Input Low: VIL	0V	-30V	6V	Input High: VIH	12V-24V	+8V	+30V
	Typical	Min	Max													
Input Low: VIL	0V	-30V	6V													
Input High: VIH	12V-24V	+8V	+30V													

Pin	Signal	Type	Function	Specifications
15	GPIO	I/O	General-Purpose	Configurable General-Purpose Input / Output
16	SWC	I/O	Single Wire CAN	

Pinout by Functionality

The following table lists the 16 enhanced model signals by functionality:

Table 11: Main Connector Signal Map (by functionality)

Pin	Signal	Type	Function	Specifications												
1	POWER_INPUT	V	Input Power 12V/24V	Typical – 12V/24V - Minimum continues – 6V (5V for up to 40ms according to ISO7637) Maximum continues – 32V												
2	POWER_GND	G	Ground													
3	Ignition Input	A	A2D Input Ignition switch	<table border="0"> <tr> <td></td> <td>Typical</td> <td>Min</td> <td>Max</td> </tr> <tr> <td>Input Low: VIL</td> <td>0V</td> <td>-30V</td> <td>6V</td> </tr> <tr> <td>Input High: VIH</td> <td>12V-24V</td> <td>+8V</td> <td>+32V</td> </tr> </table>		Typical	Min	Max	Input Low: VIL	0V	-30V	6V	Input High: VIH	12V-24V	+8V	+32V
	Typical	Min	Max													
Input Low: VIL	0V	-30V	6V													
Input High: VIH	12V-24V	+8V	+32V													
4	CAN 1 H	I/O	CAN 1 High Signal	Twisted Pair												
5	CAN 1 L	I/O	CAN 1 Low Signal	Twisted Pair												
6	J1708+ or CAN 2 H	I/O	J1708 Positive or CAN 2 High Signal	Twisted Pair												
7	J1708- or CAN 2 L	I/O	J1708 Negative or CAN 2 Low Signal	Twisted Pair												
8	O.C. Output	O	Open Collector Output 1	Max. switchable current = 300mA Max. switchable voltage = +VIN Max. saturation voltage = 0.6V												
9	RS232_TX1	I	Transmit Data (COM1)	EIA-RS232 level												
10	RS232_TX_DBG	O	Transmit Data DBG	MCU Debug port EIA-RS232 level												
11	RS232_RX_DBG	I	Receive Data DBG	MCU Debug Port EIA-RS232 level												
12	GND	G	Ground													

Pin	Signal	Type	Function	Specifications												
13	RS232_RX1	I	Receive Data (COM1)	EIA-RS232 level												
14	Automotive Input	I	Digital Input 1	<table border="1"> <thead> <tr> <th></th> <th>Typical</th> <th>Min</th> <th>Max</th> </tr> </thead> <tbody> <tr> <td>Input Low: VIL</td> <td>0V</td> <td>-30V</td> <td>6V</td> </tr> <tr> <td>Input High: VIH</td> <td>12V-24V</td> <td>+8V</td> <td>+30V</td> </tr> </tbody> </table> 0V-30V max, 12k OHM		Typical	Min	Max	Input Low: VIL	0V	-30V	6V	Input High: VIH	12V-24V	+8V	+30V
	Typical	Min	Max													
Input Low: VIL	0V	-30V	6V													
Input High: VIH	12V-24V	+8V	+30V													
15	GPIO	I/O	General-Purpose	Configurable General-Purpose Input/Output												
16	SWC	I/O	Single Wire CAN													

10. SmartCAM™ Installation

Mechanical Installation

Mounting Sunshield

The mountable sunshield of the Micronet SmartCAM™ should be attached to the vehicle's windshield using the adhesive provided in the DTK for installation.

The fast and easy-to-use permanent bonding adhesive method provides high strength and long-term durability. It is virtually invisible and keeps surfaces smooth. It can replace mechanical fasteners (rivets, welds, screws) or liquid adhesives, eliminate drilling, grinding, refinishing, screwing, welding and associated clean-up. It also creates a permanent seal against water, moisture and more.



NOTE:

In-vehicle installation instructions must be provided by a qualified installation technician.

Mounting Location and Dimensions

The sunshield can rotate every 8 degrees for click-turn positioning with two adhesive pads. Place the adhesive pads on the mounting sunshield as shown in the figure below:



Figure 18: Micronet SmartCAM™ Rear Panel Mounting Sunshield with Adhesive

Windshield Spacing

To mount the sunshield after applying the adhesive pads, press the sunshield firmly on to the vehicle windshield about four inches above the wiper blade path slightly off-center to the right like below:

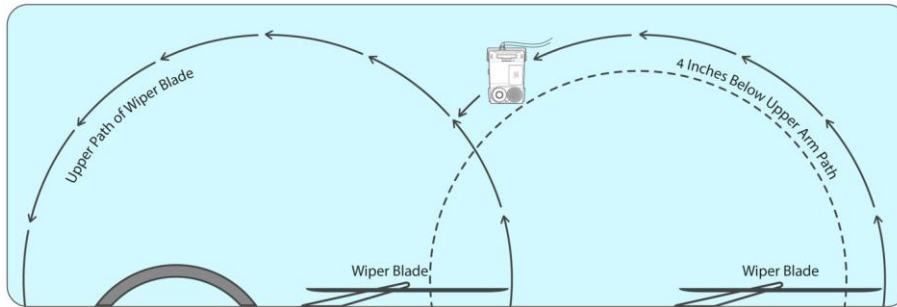

Figure 19: Micronet SmartCAM™ Single Windshield Mounting Spacing

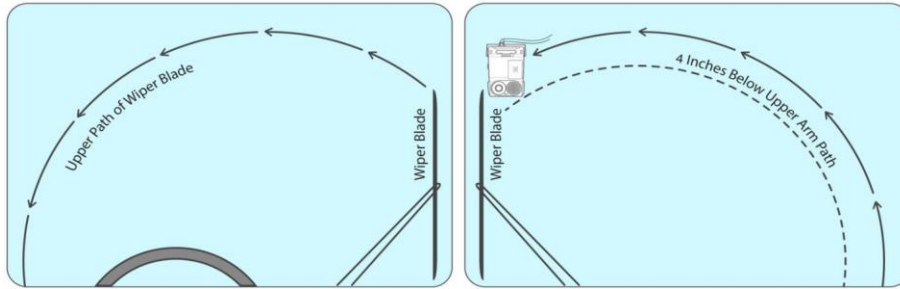

Figure 20: Micronet SmartCAM™ Double Windshield Mounting Spacing

Device Installation Steps

1. Determine the optimal positioning of the Micronet SmartCAM™ in the vehicle that provides easy access and a clear view of both the road and the display.
2. Attach the two adhesive pads to the mounting sunshield of the Micronet SmartCAM™ (make sure the sunshield is free of dust and debris).
3. Press and hold the mounting sunshield with adhesive pads on the pre-determined windshield position for at least 30 seconds.
4. Follow the cable installation steps as described in [Electrical Installation](#).

Electrical Installation

Vehicle Battery Connection

The Micronet SmartCAM™ input power connects directly to the vehicle's battery. See the Electrical Installation in Figure 21 below.

The supported nominal battery voltage supply is 12V or 24V DC, with an operating range between 8V to 30V DC.

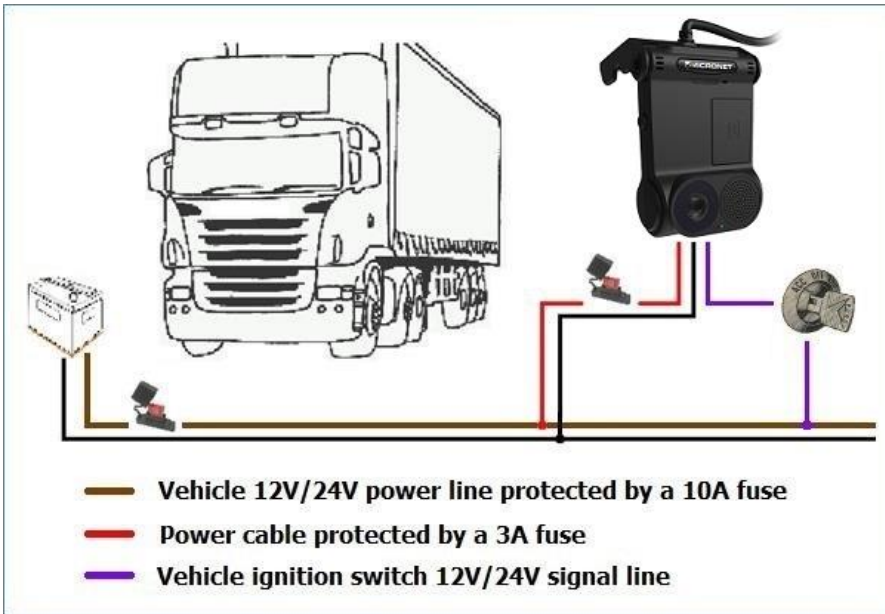

Figure 21: Electrical Installation Scheme

Electrical Installation Procedure

1. Prepare the wiring for power, ground and ignition switch in the vehicle, for connecting to the Micronet SmartCAM™ cable.
2. The power signal connects to the vehicle's power line protected by a 10A fuse. Add an inline 3A "Slow Blow" fuse with fuse holder for HHC/HHD blade-type fuses to the power cable.
3. The ground signal connects to the vehicle's ground line.
4. The ignition input signal connects to the vehicle's ignition switch line.
5. Fix the cable after verifying that all the functions are performing properly.
6. Arrange the cables using a plastic strip.



The must be connected to power before inserting the Micronet SmartCAM™ into the cradle. If the Micronet SmartCAM™ is inserted while the is not connected to power, the Micronet SmartCAM™ shuts down immediately.

11. Physical Characteristics

Table 12: Physical Characteristics

Dimension	Measurement	
<i>Micronet SmartCAM™ Dimensions & Weight</i>		
Width	6.50 inch	165 mm
Height	3.15 inch	80 mm
Depth	0.60 inch	15 mm
Weight	8.11 oz.	230 Gram

批注 [BS14]: Need all these measurements

12. Known Issues

Overview

The Micronet SmarTab 8 has some known issues discovered in the alpha launch and pre-production testing. These are listed below:

Access Point Configuration:

NOTE: No cellular connections are available in the SmartCAM Basic model which requires the device to connect via Wi-Fi. Active WiFi-Direct connections should NOT be available in specific cases i.e. no application may use the device in WiFi-Direct or Hotspot mode when update is scheduled to allow device connecting client AP in station mode.

BUG – Cellular Access Points (APs) are not pre-defined through a configuration files; neither are the APs automatically generated upon booting the Micronet SmartCAM with microSIM cards.

WORKAROUND (temporary) – Customers should predefine AP data in the Micronet SmartCAM Wi-Fi settings for internet connectivity.

SD Card Format Error:

BUG – When an SD Card is inserted to the SmartCAM, the Android OS attempts to format it as "Internal" (application) storage, which fails and displays "Not Supported" (This is a specific version limitation).

WORKAROUND (temporary) – To use the "External" (data storage) of the SD card, we recommend formatting it externally on a PC as FAT32 file system prior to inserting the SD card it to the Micronet SmartCAM device. Doing this will ensure correct behavior of the SD card as external storage.

Battery Depletion Reboot:

BUG – When the battery is depleted below a 5% threshold the Micronet SmartCAM will start booting in a reboot loop after charging for some moments.

FIX IN PROGRESS – Should be fixed by using correct battery profile in firmware.

Battery Not Charging:

BUG – The Micronet SmartCAM's battery won't fully charge and it depletes too fast due to the absence of customized battery profile.

FIX IN PROGRESS – Should be fixed by using correct battery profile in firmware.

Roadside Camera Performance:

BUG – The Micronet SmartCAM’s roadside camera performance is degraded due to an uncalibrated camera sensor.

FIX IN PROGRESS – Will be fixed by applying correct camera calibrations.

Microphone Gain:

BUG – The Micronet SmartCAM’s external microphone doesn’t provide sufficient gain.

FIX IN PROGRESS – The PCB will require a resistor of lesser value to provide the best possible gain.

IR LED Brightness:

BUG – The Micronet SmartCAM’s Infrared LED brightness of the driver side camera needs to be fine-tuned for optimal performance.

FIX IN PROGRESS – Currently undergoing testing.