



# RF TEST REPORT

**Applicant** Micronet  
**FCC ID** U8O-A9  
**Product** SmarTab-8  
**Brand** TREQ  
**Model** SmarTab-8  
**Report No.** R1912A0704-R2  
**Issue Date** March 5, 2020

TA Technology (Shanghai) Co., Ltd. tested the above equipment in accordance with the requirements in **FCC CFR47 Part 2 (2019)/ FCC CFR 47 Part 24E (2019)**. The test results show that the equipment tested is capable of demonstrating compliance with the requirements as documented in this report.

Performed by: Peng Tao

Approved by: Kai Xu

---

## TA Technology (Shanghai) Co., Ltd.

No.145, Jintang Rd, Tangzhen Industry Park, Pudong Shanghai, China

TEL: +86-021-50791141/2/3

FAX: +86-021-50791141/2/3-8000



## TABLE OF CONTENT

1. Test Laboratory .....	4
1.1. Notes of the test report.....	4
1.2. Test facility.....	4
1.3. Testing Location .....	4
2. General Description of Equipment under Test.....	5
2.3. Applicant and Manufacturer Information .....	5
2.4. General information .....	5
3. Applied Standards.....	6
4. Test Configuration.....	7
5. Test Case Results.....	8
5.1. RF Power Output.....	8
5.2. Radiates Spurious Emission .....	16
6. Main Test Instruments .....	22



## Summary of measurement results

No.	Test Case	Clause in FCC rules	Verdict
1	RF Power Output	2.1046 24.232(c)	PASS
2	Radiates Spurious Emission	2.1053 / 24.238(a)	PASS
Date of Testing: December 14, 2019~ January 17, 2020			
Note: PASS: The EUT complies with the essential requirements in the standard. FAIL: The EUT does not comply with the essential requirements in the standard. All indications of Pass/Fail in this report are opinions expressed by TA Technology (Shanghai) Co., Ltd. based on interpretations and/or observations of test results. Measurement Uncertainties were not taken into account and are published for informational purposes only.			

**Conducted test items except for RF Power Output refer to module A9 test report(Report No.: I19D00117-SRD04/ I19D00117-SRD06).**



## 1. Test Laboratory

### 1.1. Notes of the test report

This report shall not be reproduced in full or partial, without the written approval of **TA technology (shanghai) co., Ltd.** The results documented in this report apply only to the tested sample, under the conditions and modes of operation as described herein. Measurement Uncertainties were not taken into account and are published for informational purposes only. This report is written to support regulatory compliance of the applicable standards stated above.

### 1.2. Test facility

#### **FCC (Designation number: CN1179, Test Firm Registration Number: 446626)**

TA Technology (Shanghai) Co., Ltd. has been listed on the US Federal Communications Commission list of test facilities recognized to perform electromagnetic emissions measurements.

#### **A2LA (Certificate Number: 3857.01)**

TA Technology (Shanghai) Co., Ltd. has been listed by American Association for Laboratory Accreditation to perform electromagnetic emission measurement.

### 1.3. Testing Location

Company: TA Technology (Shanghai) Co., Ltd.  
Address: No.145, Jintang Rd, Tangzhen Industry Park, Pudong  
City: Shanghai  
Post code: 201201  
Country: P. R. China  
Contact: Xu Kai  
Telephone: +86-021-50791141/2/3  
Fax: +86-021-50791141/2/3-8000  
Website: <http://www.ta-shanghai.com>  
E-mail: [xukai@ta-shanghai.com](mailto:xukai@ta-shanghai.com)

## 2. General Description of Equipment under Test

### 2.3. Applicant and Manufacturer Information

Applicant	Micronet
Applicant address	1865 West 2100 South, Suite 2 Salt Lake City, Utah 84119 United States
Manufacturer	Micronet
Manufacturer address	1865 West 2100 South, Suite 2 Salt Lake City, Utah 84119 United States

### 2.4. General information

EUT Description			
Model	SmarTab-8		
IMEI	353436100010544		
Hardware Version	A9: C801_V1.00_PCB		
Software Version	MSTAB8_9.00.2.7.0		
Power Supply	Battery/AC adapter		
Antenna Type	Internal Antenna		
Antenna Gain	1.30dBi		
Test Mode(s)	GSM1900; WCDMA Band II; LTE Band 2;		
Test Modulation	(GSM)GMSK,8PSK; (WCDMA) BPSK, QPSK,16QAM; (LTE)QPSK,16QAM		
GPRS Multislot Class	12		
EGPRS Multislot Class	12		
HSDPA UE Category	24		
HSUPA UE Category	7		
LTE Category	4		
Rated Power Supply Voltage	3.8V		
Extreme Voltage	Minimum: 3.7V    Maximum: 4.2V		
Extreme Temperature	Lowest: -20°C    Highest: +70°C		
Operating Frequency Range(s)	Band	Tx (MHz)	Rx (MHz)
	GSM1900	1850 ~ 1910	1930 ~ 1990
	WCDMA Band II	1850 ~ 1910	1930 ~ 1990
	LTE Band 2	1850 ~ 1910	1930 ~ 1990
EUT Accessory			
Battery	Manufacturer: Howell Model: HWE30100100 6600mAH (ENH.)		
Note: 1. The EUT is sent from the applicant to TA and the information of the EUT is declared by the applicant.			

### 3. Applied Standards

According to the specifications of the manufacturer, it must comply with the requirements of the following standards:

**Test standards:**

**FCC CFR 47 Part 24E (2019)**

**ANSI C63.26 (2015)**

**Reference standard:**

**FCC CFR47 Part 2 (2019)**

**KDB 971168 D01 Power Meas License Digital Systems v03r01**

### 4. Test Configuration

Radiated measurements are performed by rotating the EUT in three different orthogonal test planes. EUT stand-up position (Z axis), lie-down position (X, Y axis). Receiver antenna polarization (horizontal and vertical), the worst emission was found in position (X axis, horizontal polarization) and the worst case was recorded.

All mode and data rates and positions and RB size and modulations were investigated.

Subsequently, only the worst case emissions are reported.

The following testing in GSM/WCDMA/LTE is set based on the maximum RF Output Power.

Test modes are chosen to be reported as the worst case configuration below:

Test items	Modes/Modulation	
	GSM 1900	WCDMA Band II
RF Power Output	GSM GPRS EGPRS	RMC HSDPA/HSUPA
Radiates Spurious Emission	GSM	RMC

Test modes are chosen to be reported as the worst case configuration below for LTE Band 2:

Test items	Bandwidth (MHz)						Modulation		RB			Test Channel		
	1.4	3	5	10	15	20	QPSK	16QAM	1	50%	100%	L	M	H
RF Power Output	O	O	O	O	O	O	O	O	O	O	O	O	O	O
Radiates Spurious Emission	O	-	O	-	-	O	O	-	O	-	-	-	O	-
Note	1. The mark "O" means that this configuration is chosen for testing. 2. The mark "-" means that this configuration is not testing.													

## 5. Test Case Results

### 5.1. RF Power Output

#### Ambient condition

Temperature	Relative humidity	Pressure
23°C ~25°C	45%~50%	101.5kPa

#### Methods of Measurement

During the process of the testing, The EUT is controlled by the Base Station Simulator to ensure max power transmission and proper modulation.

#### Test Setup

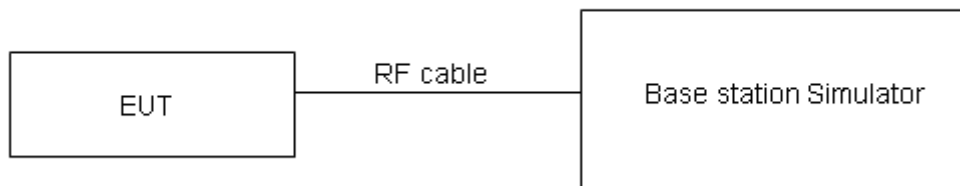

The loss between RF output port of the EUT and the input port of the tester has been taken into consideration.

#### Limits

No specific RF power output requirements in part 2.1046.

#### Measurement Uncertainty

The assessed measurement uncertainty to ensure 95% confidence level for the normal distribution is with the coverage factor  $k = 2$ ,  $U = 0.4$  dB for RF power output.



**Test Results**

GSM 1900		Conducted Power (dBm)		
		Channel 512	Channel 661	Channel 810
		1850.2 (MHz)	1880 (MHz)	1909.8 (MHz)
GSM	Results	27.67	27.59	27.40
GPRS/EGPRS (GMSK)	1TXslot	27.68	27.58	27.65
	2TXslots	27.28	27.20	27.00
	3TXslots	26.10	26.07	25.92
	4TXslots	24.95	24.97	24.73
EGPRS (8PSK)	1TXslot	23.05	22.98	22.92
	2TXslots	21.93	21.96	21.97
	3TXslots	20.97	20.94	20.96
	4TXslots	19.92	19.99	19.95

WCDMA Band II		Conducted Power (dBm)		
		Channel 9262	Channel 9400	Channel 9538
		1852.4 (MHz)	1880 (MHz)	1907.6 (MHz)
RMC		21.45	21.63	21.86
HSDPA	Sub - Test 1	20.91	21.05	21.30
	Sub - Test 2	20.90	21.07	21.27
	Sub - Test 3	20.37	20.57	20.79
	Sub - Test 4	20.38	20.58	20.77
HSUPA	Sub - Test 1	20.87	21.04	21.25
	Sub - Test 2	19.86	20.02	20.24
	Sub - Test 3	20.33	20.50	20.73
	Sub - Test 4	19.79	19.99	20.21
	Sub - Test 5	20.80	20.97	21.19



Band	Bandwidth (MHz)	UL Channel	RB Size	RB Position	Modulation	Power (dBm)	high Limit (dBm)	Verdict
LTE Band2	1.4	18607	1	#0	QPSK	22.10	37	PASS
LTE Band2	1.4	18607	1	#Mid	QPSK	22.09	37	PASS
LTE Band2	1.4	18607	1	#Max	QPSK	22.05	37	PASS
LTE Band2	1.4	18607	3	#0	QPSK	21.85	37	PASS
LTE Band2	1.4	18607	3	#Mid	QPSK	21.85	37	PASS
LTE Band2	1.4	18607	3	#Max	QPSK	21.85	37	PASS
LTE Band2	1.4	18607	6	#0	QPSK	21.01	37	PASS
LTE Band2	1.4	18607	1	#0	QAM16	20.89	37	PASS
LTE Band2	1.4	18607	1	#Mid	QAM16	20.63	37	PASS
LTE Band2	1.4	18607	1	#Max	QAM16	20.81	37	PASS
LTE Band2	1.4	18607	3	#0	QAM16	20.97	37	PASS
LTE Band2	1.4	18607	3	#Mid	QAM16	20.96	37	PASS
LTE Band2	1.4	18607	3	#Max	QAM16	21.09	37	PASS
LTE Band2	1.4	18607	6	#0	QAM16	20.05	37	PASS
LTE Band2	1.4	18900	1	#0	QPSK	22.04	37	PASS
LTE Band2	1.4	18900	1	#Mid	QPSK	22.14	37	PASS
LTE Band2	1.4	18900	1	#Max	QPSK	21.82	37	PASS
LTE Band2	1.4	18900	3	#0	QPSK	21.82	37	PASS
LTE Band2	1.4	18900	3	#Mid	QPSK	21.91	37	PASS
LTE Band2	1.4	18900	3	#Max	QPSK	21.92	37	PASS
LTE Band2	1.4	18900	6	#0	QPSK	20.92	37	PASS
LTE Band2	1.4	18900	1	#0	QAM16	21.43	37	PASS
LTE Band2	1.4	18900	1	#Mid	QAM16	21.55	37	PASS
LTE Band2	1.4	18900	1	#Max	QAM16	21.55	37	PASS
LTE Band2	1.4	18900	3	#0	QAM16	20.89	37	PASS
LTE Band2	1.4	18900	3	#Mid	QAM16	21.03	37	PASS
LTE Band2	1.4	18900	3	#Max	QAM16	21.04	37	PASS
LTE Band2	1.4	18900	6	#0	QAM16	19.85	37	PASS
LTE Band2	1.4	19193	1	#0	QPSK	21.75	37	PASS
LTE Band2	1.4	19193	1	#Mid	QPSK	22.21	37	PASS
LTE Band2	1.4	19193	1	#Max	QPSK	22.05	37	PASS
LTE Band2	1.4	19193	3	#0	QPSK	21.89	37	PASS
LTE Band2	1.4	19193	3	#Mid	QPSK	21.99	37	PASS
LTE Band2	1.4	19193	3	#Max	QPSK	21.66	37	PASS
LTE Band2	1.4	19193	6	#0	QPSK	20.82	37	PASS
LTE Band2	1.4	19193	1	#0	QAM16	20.87	37	PASS
LTE Band2	1.4	19193	1	#Mid	QAM16	20.91	37	PASS
LTE Band2	1.4	19193	1	#Max	QAM16	20.94	37	PASS
LTE Band2	1.4	19193	3	#0	QAM16	21.31	37	PASS
LTE Band2	1.4	19193	3	#Mid	QAM16	21.30	37	PASS



LTE Band2	1.4	19193	3	#Max	QAM16	21.41	37	PASS
LTE Band2	1.4	19193	6	#0	QAM16	20.37	37	PASS
LTE Band2	3	18615	1	#0	QPSK	21.91	37	PASS
LTE Band2	3	18615	1	#Mid	QPSK	21.93	37	PASS
LTE Band2	3	18615	1	#Max	QPSK	21.94	37	PASS
LTE Band2	3	18615	8	#0	QPSK	20.97	37	PASS
LTE Band2	3	18615	8	#Mid	QPSK	20.98	37	PASS
LTE Band2	3	18615	8	#Max	QPSK	20.98	37	PASS
LTE Band2	3	18615	15	#0	QPSK	21.01	37	PASS
LTE Band2	3	18615	1	#0	QAM16	20.87	37	PASS
LTE Band2	3	18615	1	#Mid	QAM16	21.55	37	PASS
LTE Band2	3	18615	1	#Max	QAM16	21.52	37	PASS
LTE Band2	3	18615	8	#0	QAM16	20.08	37	PASS
LTE Band2	3	18615	8	#Mid	QAM16	20.08	37	PASS
LTE Band2	3	18615	8	#Max	QAM16	20.14	37	PASS
LTE Band2	3	18615	15	#0	QAM16	20.11	37	PASS
LTE Band2	3	18900	1	#0	QPSK	21.84	37	PASS
LTE Band2	3	18900	1	#Mid	QPSK	21.83	37	PASS
LTE Band2	3	18900	1	#Max	QPSK	21.89	37	PASS
LTE Band2	3	18900	8	#0	QPSK	20.89	37	PASS
LTE Band2	3	18900	8	#Mid	QPSK	21.02	37	PASS
LTE Band2	3	18900	8	#Max	QPSK	20.91	37	PASS
LTE Band2	3	18900	15	#0	QPSK	21.02	37	PASS
LTE Band2	3	18900	1	#0	QAM16	21.25	37	PASS
LTE Band2	3	18900	1	#Mid	QAM16	21.34	37	PASS
LTE Band2	3	18900	1	#Max	QAM16	21.28	37	PASS
LTE Band2	3	18900	8	#0	QAM16	19.80	37	PASS
LTE Band2	3	18900	8	#Mid	QAM16	19.78	37	PASS
LTE Band2	3	18900	8	#Max	QAM16	19.69	37	PASS
LTE Band2	3	18900	15	#0	QAM16	19.71	37	PASS
LTE Band2	3	19185	1	#0	QPSK	21.66	37	PASS
LTE Band2	3	19185	1	#Mid	QPSK	21.63	37	PASS
LTE Band2	3	19185	1	#Max	QPSK	21.74	37	PASS
LTE Band2	3	19185	8	#0	QPSK	20.85	37	PASS
LTE Band2	3	19185	8	#Mid	QPSK	20.85	37	PASS
LTE Band2	3	19185	8	#Max	QPSK	20.78	37	PASS
LTE Band2	3	19185	15	#0	QPSK	20.87	37	PASS
LTE Band2	3	19185	1	#0	QAM16	20.62	37	PASS
LTE Band2	3	19185	1	#Mid	QAM16	20.25	37	PASS
LTE Band2	3	19185	1	#Max	QAM16	20.31	37	PASS
LTE Band2	3	19185	8	#0	QAM16	19.53	37	PASS
LTE Band2	3	19185	8	#Mid	QAM16	19.53	37	PASS
LTE Band2	3	19185	8	#Max	QAM16	19.53	37	PASS



LTE Band2	3	19185	15	#0	QAM16	19.74	37	PASS
LTE Band2	5	18625	1	#0	QPSK	21.85	37	PASS
LTE Band2	5	18625	1	#Mid	QPSK	21.97	37	PASS
LTE Band2	5	18625	1	#Max	QPSK	21.85	37	PASS
LTE Band2	5	18625	12	#0	QPSK	21.06	37	PASS
LTE Band2	5	18625	12	#Mid	QPSK	21.07	37	PASS
LTE Band2	5	18625	12	#Max	QPSK	21.04	37	PASS
LTE Band2	5	18625	25	#0	QPSK	21.02	37	PASS
LTE Band2	5	18625	1	#0	QAM16	20.69	37	PASS
LTE Band2	5	18625	1	#Mid	QAM16	21.32	37	PASS
LTE Band2	5	18625	1	#Max	QAM16	21.27	37	PASS
LTE Band2	5	18625	12	#0	QAM16	20.00	37	PASS
LTE Band2	5	18625	12	#Mid	QAM16	20.09	37	PASS
LTE Band2	5	18625	12	#Max	QAM16	19.97	37	PASS
LTE Band2	5	18625	25	#0	QAM16	19.90	37	PASS
LTE Band2	5	18900	1	#0	QPSK	21.68	37	PASS
LTE Band2	5	18900	1	#Mid	QPSK	21.84	37	PASS
LTE Band2	5	18900	1	#Max	QPSK	21.76	37	PASS
LTE Band2	5	18900	12	#0	QPSK	20.90	37	PASS
LTE Band2	5	18900	12	#Mid	QPSK	20.91	37	PASS
LTE Band2	5	18900	12	#Max	QPSK	20.94	37	PASS
LTE Band2	5	18900	25	#0	QPSK	20.93	37	PASS
LTE Band2	5	18900	1	#0	QAM16	21.11	37	PASS
LTE Band2	5	18900	1	#Mid	QAM16	21.23	37	PASS
LTE Band2	5	18900	1	#Max	QAM16	21.05	37	PASS
LTE Band2	5	18900	12	#0	QAM16	19.64	37	PASS
LTE Band2	5	18900	12	#Mid	QAM16	19.64	37	PASS
LTE Band2	5	18900	12	#Max	QAM16	19.72	37	PASS
LTE Band2	5	18900	25	#0	QAM16	19.72	37	PASS
LTE Band2	5	19175	1	#0	QPSK	21.96	37	PASS
LTE Band2	5	19175	1	#Mid	QPSK	21.80	37	PASS
LTE Band2	5	19175	1	#Max	QPSK	21.67	37	PASS
LTE Band2	5	19175	12	#0	QPSK	20.80	37	PASS
LTE Band2	5	19175	12	#Mid	QPSK	20.81	37	PASS
LTE Band2	5	19175	12	#Max	QPSK	20.83	37	PASS
LTE Band2	5	19175	25	#0	QPSK	20.87	37	PASS
LTE Band2	5	19175	1	#0	QAM16	20.80	37	PASS
LTE Band2	5	19175	1	#Mid	QAM16	20.76	37	PASS
LTE Band2	5	19175	1	#Max	QAM16	20.92	37	PASS
LTE Band2	5	19175	12	#0	QAM16	19.86	37	PASS
LTE Band2	5	19175	12	#Mid	QAM16	19.87	37	PASS
LTE Band2	5	19175	12	#Max	QAM16	19.86	37	PASS
LTE Band2	5	19175	25	#0	QAM16	19.76	37	PASS



LTE Band2	10	18650	1	#0	QPSK	21.95	37	PASS
LTE Band2	10	18650	1	#Mid	QPSK	21.92	37	PASS
LTE Band2	10	18650	1	#Max	QPSK	21.92	37	PASS
LTE Band2	10	18650	25	#0	QPSK	21.06	37	PASS
LTE Band2	10	18650	25	#Mid	QPSK	21.06	37	PASS
LTE Band2	10	18650	25	#Max	QPSK	21.09	37	PASS
LTE Band2	10	18650	50	#0	QPSK	21.07	37	PASS
LTE Band2	10	18650	1	#0	QAM16	21.08	37	PASS
LTE Band2	10	18650	1	#Mid	QAM16	21.71	37	PASS
LTE Band2	10	18650	1	#Max	QAM16	21.65	37	PASS
LTE Band2	10	18650	25	#0	QAM16	20.07	37	PASS
LTE Band2	10	18650	25	#Mid	QAM16	20.07	37	PASS
LTE Band2	10	18650	25	#Max	QAM16	20.12	37	PASS
LTE Band2	10	18650	50	#0	QAM16	20.04	37	PASS
LTE Band2	10	18900	1	#0	QPSK	21.89	37	PASS
LTE Band2	10	18900	1	#Mid	QPSK	22.11	37	PASS
LTE Band2	10	18900	1	#Max	QPSK	21.90	37	PASS
LTE Band2	10	18900	25	#0	QPSK	20.92	37	PASS
LTE Band2	10	18900	25	#Mid	QPSK	20.93	37	PASS
LTE Band2	10	18900	25	#Max	QPSK	20.95	37	PASS
LTE Band2	10	18900	50	#0	QPSK	21.00	37	PASS
LTE Band2	10	18900	1	#0	QAM16	21.57	37	PASS
LTE Band2	10	18900	1	#Mid	QAM16	21.43	37	PASS
LTE Band2	10	18900	1	#Max	QAM16	21.65	37	PASS
LTE Band2	10	18900	25	#0	QAM16	19.87	37	PASS
LTE Band2	10	18900	25	#Mid	QAM16	19.87	37	PASS
LTE Band2	10	18900	25	#Max	QAM16	20.13	37	PASS
LTE Band2	10	18900	50	#0	QAM16	20.03	37	PASS
LTE Band2	10	19150	1	#0	QPSK	21.87	37	PASS
LTE Band2	10	19150	1	#Mid	QPSK	21.98	37	PASS
LTE Band2	10	19150	1	#Max	QPSK	21.97	37	PASS
LTE Band2	10	19150	25	#0	QPSK	20.96	37	PASS
LTE Band2	10	19150	25	#Mid	QPSK	20.98	37	PASS
LTE Band2	10	19150	25	#Max	QPSK	20.82	37	PASS
LTE Band2	10	19150	50	#0	QPSK	20.90	37	PASS
LTE Band2	10	19150	1	#0	QAM16	20.78	37	PASS
LTE Band2	10	19150	1	#Mid	QAM16	20.84	37	PASS
LTE Band2	10	19150	1	#Max	QAM16	20.29	37	PASS
LTE Band2	10	19150	25	#0	QAM16	20.15	37	PASS
LTE Band2	10	19150	25	#Mid	QAM16	20.07	37	PASS
LTE Band2	10	19150	25	#Max	QAM16	19.91	37	PASS
LTE Band2	10	19150	50	#0	QAM16	19.91	37	PASS
LTE Band2	15	18675	1	#0	QPSK	22.01	37	PASS



LTE Band2	15	18675	1	#Mid	QPSK	22.01	37	PASS
LTE Band2	15	18675	1	#Max	QPSK	22.09	37	PASS
LTE Band2	15	18675	36	#0	QPSK	21.07	37	PASS
LTE Band2	15	18675	36	#Mid	QPSK	21.06	37	PASS
LTE Band2	15	18675	36	#Max	QPSK	21.00	37	PASS
LTE Band2	15	18675	75	#0	QPSK	20.97	37	PASS
LTE Band2	15	18675	1	#0	QAM16	21.20	37	PASS
LTE Band2	15	18675	1	#Mid	QAM16	21.42	37	PASS
LTE Band2	15	18675	1	#Max	QAM16	20.94	37	PASS
LTE Band2	15	18675	36	#0	QAM16	19.90	37	PASS
LTE Band2	15	18675	36	#Mid	QAM16	19.89	37	PASS
LTE Band2	15	18675	36	#Max	QAM16	19.95	37	PASS
LTE Band2	15	18675	75	#0	QAM16	19.96	37	PASS
LTE Band2	15	18900	1	#0	QPSK	21.68	37	PASS
LTE Band2	15	18900	1	#Mid	QPSK	21.78	37	PASS
LTE Band2	15	18900	1	#Max	QPSK	21.78	37	PASS
LTE Band2	15	18900	36	#0	QPSK	20.85	37	PASS
LTE Band2	15	18900	36	#Mid	QPSK	20.85	37	PASS
LTE Band2	15	18900	36	#Max	QPSK	20.99	37	PASS
LTE Band2	15	18900	75	#0	QPSK	20.87	37	PASS
LTE Band2	15	18900	1	#0	QAM16	21.35	37	PASS
LTE Band2	15	18900	1	#Mid	QAM16	21.46	37	PASS
LTE Band2	15	18900	1	#Max	QAM16	21.44	37	PASS
LTE Band2	15	18900	36	#0	QAM16	20.03	37	PASS
LTE Band2	15	18900	36	#Mid	QAM16	19.82	37	PASS
LTE Band2	15	18900	36	#Max	QAM16	19.95	37	PASS
LTE Band2	15	18900	75	#0	QAM16	19.92	37	PASS
LTE Band2	15	19125	1	#0	QPSK	21.94	37	PASS
LTE Band2	15	19125	1	#Mid	QPSK	21.83	37	PASS
LTE Band2	15	19125	1	#Max	QPSK	21.62	37	PASS
LTE Band2	15	19125	36	#0	QPSK	21.01	37	PASS
LTE Band2	15	19125	36	#Mid	QPSK	21.02	37	PASS
LTE Band2	15	19125	36	#Max	QPSK	20.85	37	PASS
LTE Band2	15	19125	75	#0	QPSK	20.95	37	PASS
LTE Band2	15	19125	1	#0	QAM16	20.62	37	PASS
LTE Band2	15	19125	1	#Mid	QAM16	20.51	37	PASS
LTE Band2	15	19125	1	#Max	QAM16	19.97	37	PASS
LTE Band2	15	19125	36	#0	QAM16	19.99	37	PASS
LTE Band2	15	19125	36	#Mid	QAM16	20.00	37	PASS
LTE Band2	15	19125	36	#Max	QAM16	19.69	37	PASS
LTE Band2	15	19125	75	#0	QAM16	19.76	37	PASS
LTE Band2	20	18700	1	#0	QPSK	21.79	37	PASS
LTE Band2	20	18700	1	#Mid	QPSK	22.14	37	PASS





LTE Band2	20	18700	1	#Max	QPSK	21.80	37	PASS
LTE Band2	20	18700	50	#0	QPSK	21.09	37	PASS
LTE Band2	20	18700	50	#Mid	QPSK	21.00	37	PASS
LTE Band2	20	18700	50	#Max	QPSK	21.05	37	PASS
LTE Band2	20	18700	100	#0	QPSK	21.00	37	PASS
LTE Band2	20	18700	1	#0	QAM16	21.40	37	PASS
LTE Band2	20	18700	1	#Mid	QAM16	21.66	37	PASS
LTE Band2	20	18700	1	#Max	QAM16	21.05	37	PASS
LTE Band2	20	18700	50	#0	QAM16	20.16	37	PASS
LTE Band2	20	18700	50	#Mid	QAM16	20.07	37	PASS
LTE Band2	20	18700	50	#Max	QAM16	19.93	37	PASS
LTE Band2	20	18700	100	#0	QAM16	20.07	37	PASS
LTE Band2	20	18900	1	#0	QPSK	21.88	37	PASS
LTE Band2	20	18900	1	#Mid	QPSK	22.08	37	PASS
LTE Band2	20	18900	1	#Max	QPSK	22.09	37	PASS
LTE Band2	20	18900	50	#0	QPSK	20.88	37	PASS
LTE Band2	20	18900	50	#Mid	QPSK	20.88	37	PASS
LTE Band2	20	18900	50	#Max	QPSK	20.98	37	PASS
LTE Band2	20	18900	100	#0	QPSK	20.93	37	PASS
LTE Band2	20	18900	1	#0	QAM16	20.58	37	PASS
LTE Band2	20	18900	1	#Mid	QAM16	20.73	37	PASS
LTE Band2	20	18900	1	#Max	QAM16	20.59	37	PASS
LTE Band2	20	18900	50	#0	QAM16	19.80	37	PASS
LTE Band2	20	18900	50	#Mid	QAM16	19.86	37	PASS
LTE Band2	20	18900	50	#Max	QAM16	19.84	37	PASS
LTE Band2	20	18900	100	#0	QAM16	19.87	37	PASS
LTE Band2	20	19100	1	#0	QPSK	21.94	37	PASS
LTE Band2	20	19100	1	#Mid	QPSK	22.23	37	PASS
LTE Band2	20	19100	1	#Max	QPSK	21.80	37	PASS
LTE Band2	20	19100	50	#0	QPSK	21.04	37	PASS
LTE Band2	20	19100	50	#Mid	QPSK	21.05	37	PASS
LTE Band2	20	19100	50	#Max	QPSK	20.89	37	PASS
LTE Band2	20	19100	100	#0	QPSK	21.04	37	PASS
LTE Band2	20	19100	1	#0	QAM16	20.96	37	PASS
LTE Band2	20	19100	1	#Mid	QAM16	21.40	37	PASS
LTE Band2	20	19100	1	#Max	QAM16	20.25	37	PASS
LTE Band2	20	19100	50	#0	QAM16	20.03	37	PASS
LTE Band2	20	19100	50	#Mid	QAM16	20.03	37	PASS
LTE Band2	20	19100	50	#Max	QAM16	19.79	37	PASS
LTE Band2	20	19100	100	#0	QAM16	20.14	37	PASS

## 5.2. Radiates Spurious Emission

### Ambient condition

Temperature	Relative humidity	Pressure
23°C ~25°C	45%~50%	101.5kPa

### Method of Measurement

- The testing follows FCC KDB 971168 v03r01 Section 5.8 and ANSI C63.26 (2015).
- Below 1GHz: The EUT is placed on a turntable 0.8 meters above the ground in the chamber, 3 meter away from the antenna. The maximal emission value is acquired by adjusting the antenna height, polarisation and turntable azimuth. Normally, the height range of antenna is 1 m to 4 m, the azimuth range of turntable is 0° to 360°, and the receive antenna has two polarizations Vertical (V) and Horizontal (H). Above 1GHz: (Note: the FCC's permission to use 1.5m as an alternative per TCBC Conf call of Dec. 2, 2014.) The EUT is placed on a turntable 1.5 meters above the ground in the chamber, 3 meter away from the antenna. The maximal emission value is acquired by adjusting the antenna height, polarisation and turntable azimuth. Normally, the height range of antenna is 1 m to 4 m, the azimuth range of turntable is 0° to 360°, and the receive antenna has two polarizations Vertical (V) and Horizontal (H).
- A loop antenna, A log-periodic antenna or horn antenna shall be substituted in place of the EUT. The log-periodic antenna will be driven by a signal generator and the level will be adjusted till the same power value on the spectrum analyzer or receiver. The level of the spurious emissions can be calculated through the level of the signal generator, cable loss, the gain of the substitution antenna and the reading of the spectrum analyzer or receiver.
- The EUT is then put into continuously transmitting mode at its maximum power level during the test. Set Test Receiver or Spectrum RBW=200Hz,VBW=600Hz for 9kHz150kHz , RBW=10kHz, VBW=30kHz 150kHz-30MHz , RBW=100kHz,VBW=300kHz for 30MHz to 1GHz and RBW=1MHz, VBW=3MHz for above 1GHz, And the maximum value of the receiver should be recorded as (Pr).
- The EUT shall be replaced by a substitution antenna. In the chamber, an substitution antenna for the frequency band of interest is placed at the reference point of the chamber. An RF Signal source for the frequency band of interest is connected to the substitution antenna with a cable that has been constructed to not interfere with the radiation pattern of the antenna. A power (PMea) is applied to the input of the substitution antenna, and adjust the level of the signal generator output until the value of the receiver reach the previously recorded (Pr). The power of signal source (PMea) is recorded. The test should be performed by rotating the test item and adjusting the receiving antenna polarization.
- A amplifier should be connected to the Signal Source output port. And the cable should be connect between the Amplifier and the Substitution Antenna. The cable loss (Pcl) ,the Substitution Antenna Gain (Ga) and the Amplifier Gain (PAg) should be recorded after test.
- The measurement results are obtained as described below:  
 $Power(EIRP)=PMea- PAg - Pcl + Ga$   
 The measurement results are amend as described below:  
 $Power(EIRP)=PMea- Pcl + Ga$
- This value is EIRP since the measurement is calibrated using an antenna of known gain (2.15 dBi)



and known input power. ERP can be calculated from EIRP by subtracting the gain of the dipole,  $ERP = EIRP - 2.15\text{dBi}$ .

The modulation mode and RB allocation refer to section 5.1, using the maximum output power configuration.

**Test setup**

**9KHz ~ 30MHz**

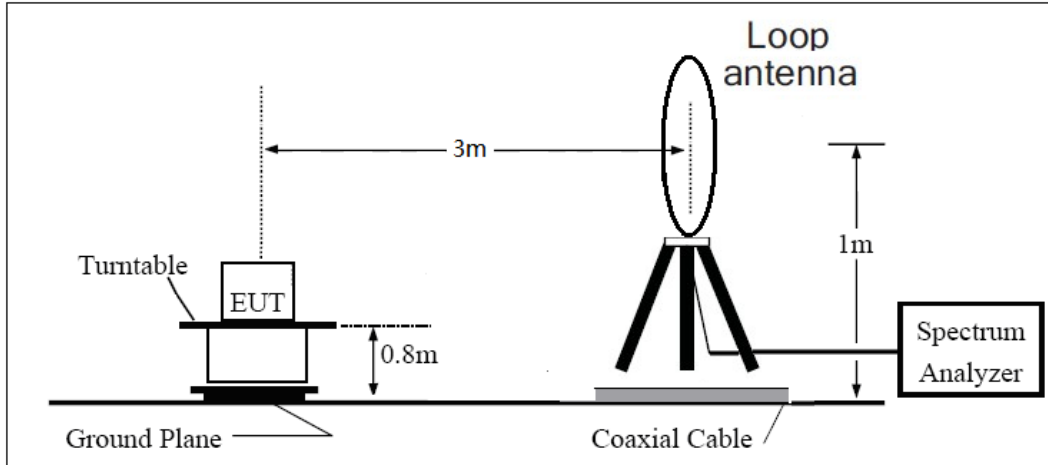

**30MHz ~ 1GHz**

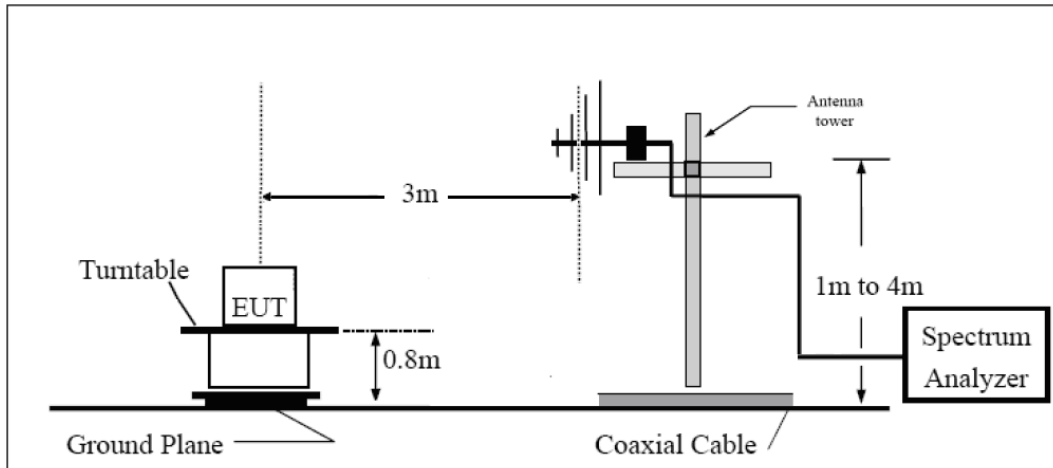

**Above 1GHz**

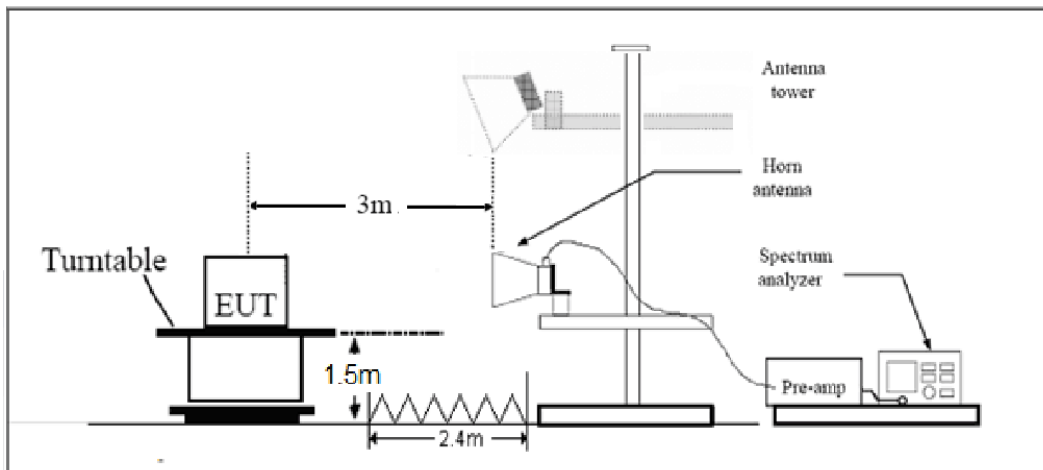



Note: Area side: 2.4mX3.6m

### Limits

Rule Part 24.238(a) specifies that “on any frequency outside a licensee's frequency block, the power of any emission shall be attenuated below the transmitter power (P) by at least  $43 + 10 \log_{10}(P)$  dB.”

Limit	-13 dBm
-------	---------

### Measurement Uncertainty

The assessed measurement uncertainty to ensure 95% confidence level for the normal distribution is with the coverage factor  $k = 1.96$ ,  $U = 3.55$  dB.

**Test Result**

Sweep the whole frequency band through the range from 9kHz to the 10th harmonic of the carrier, the emissions below the noise floor will not be recorded in the report.

GSM 1900 CH-Middle

Harmonic	Frequency (MHz)	SG (dBm)	Cable Loss (dB)	Gain (dBi)	Antenna Polarization	EIRP Level (dBm)	Limit (dBm)	Margin (dB)	Azimuth (deg)
2	3760.0	-58.74	5.10	11.05	Horizontal	-52.79	-13.00	39.79	0
3	5640.0	-58.02	5.42	12.65	Horizontal	-50.79	-13.00	37.79	180
4	7520.0	-55.40	6.70	13.85	Horizontal	-48.25	-13.00	35.25	315
5	9400.0	-54.45	7.01	14.75	Horizontal	-46.71	-13.00	33.71	45
6	11280.0	-53.10	7.48	15.95	Horizontal	-44.63	-13.00	31.63	135
7	13160.0	-51.76	7.51	16.55	Horizontal	-42.72	-13.00	29.72	90
8	15040.0	-50.83	8.24	15.35	Horizontal	-43.72	-13.00	30.72	0
9	16920.0	-45.23	8.41	14.95	Horizontal	-38.69	-13.00	25.69	180
10	18800.0	-	-	-	-	-	-	-	-

Note: 1.The other Spurious RF Radiated emissions level is no more than noise floor.  
 2. The worst emission was found in the antenna is Horizontal position.

WCDMA Band II CH-Middle

Harmonic	Frequency (MHz)	SG (dBm)	Cable Loss (dB)	Gain (dBi)	Antenna Polarization	EIRP Level (dBm)	Limit (dBm)	Margin (dB)	Azimuth (deg)
2	3760.0	-58.32	5.10	11.05	Horizontal	-52.37	-13.00	39.37	135
3	5640.0	-53.73	5.42	12.65	Horizontal	-46.50	-13.00	33.50	90
4	7520.0	-55.85	6.70	13.85	Horizontal	-48.70	-13.00	35.70	0
5	9400.0	-53.70	7.01	14.75	Horizontal	-45.96	-13.00	32.96	45
6	11280.0	-53.07	7.48	15.95	Horizontal	-44.60	-13.00	31.60	90
7	13160.0	-50.94	7.51	16.55	Horizontal	-41.90	-13.00	28.90	315
8	15040.0	-49.91	8.24	15.35	Horizontal	-42.80	-13.00	29.80	225
9	16920.0	-45.84	8.41	14.95	Horizontal	-39.30	-13.00	26.30	135
10	18800.0	-	-	-	-	-	-	-	-

Note: 1.The other Spurious RF Radiated emissions level is no more than noise floor.  
 2. The worst emission was found in the antenna is Horizontal position.

LTE Band 2 1.4MHz CH-Middle

Harmonic	Frequency (MHz)	SG (dBm)	Cable Loss (dB)	Gain (dBi)	Antenna Polarization	EIRP Level (dBm)	Limit (dBm)	Margin (dB)	Azimuth (deg)
2	3759.0	-58.64	5.10	11.05	Horizontal	-52.69	-13.00	39.69	90
3	5638.9	-50.72	5.42	12.65	Horizontal	-43.49	-13.00	30.49	0
4	7520.0	-56.25	6.70	13.85	Horizontal	-49.10	-13.00	36.10	0
5	9400.0	-54.44	7.01	14.75	Horizontal	-46.70	-13.00	33.70	45
6	11280.0	-53.57	7.48	15.95	Horizontal	-45.10	-13.00	32.10	90
7	13160.0	-51.64	7.51	16.55	Horizontal	-42.60	-13.00	29.60	225
8	15040.0	-49.81	8.24	15.35	Horizontal	-42.70	-13.00	29.70	135
9	16920.0	-46.34	8.41	14.95	Horizontal	-39.80	-13.00	26.80	90
10	18800.0	-	-	-	-	-	-	-	-

Note: 1.The other Spurious RF Radiated emissions level is no more than noise floor.  
2. The worst emission was found in the antenna is Horizontal position.

LTE Band 2 5MHz CH-Middle

Harmonic	Frequency (MHz)	SG (dBm)	Cable Loss (dB)	Gain (dBi)	Antenna Polarization	EIRP Level (dBm)	Limit (dBm)	Margin (dB)	Azimuth (deg)
2	3755.6	-58.35	5.10	11.05	Horizontal	-52.40	-13.00	39.40	135
3	5633.6	-49.13	5.42	12.65	Horizontal	-41.90	-13.00	28.90	270
4	7520.0	-55.35	6.70	13.85	Horizontal	-48.20	-13.00	35.20	315
5	9400.0	-55.14	7.01	14.75	Horizontal	-47.40	-13.00	34.40	45
6	11280.0	-53.87	7.48	15.95	Horizontal	-45.40	-13.00	32.40	180
7	13160.0	-52.04	7.51	16.55	Horizontal	-43.00	-13.00	30.00	135
8	15040.0	-50.71	8.24	15.35	Horizontal	-43.60	-13.00	30.60	90
9	16920.0	-45.64	8.41	14.95	Horizontal	-39.10	-13.00	26.10	0
10	18800.0	-	-	-	-	-	-	-	-

Note: 1.The other Spurious RF Radiated emissions level is no more than noise floor.  
2. The worst emission was found in the antenna is Horizontal position.

LTE Band 2 20MHz CH-Middle

Harmonic	Frequency (MHz)	SG (dBm)	Cable Loss (dB)	Gain (dBi)	Antenna Polarization	EIRP Level (dBm)	Limit (dBm)	Margin (dB)	Azimuth (deg)
2	3742.1	-58.93	5.10	11.05	Horizontal	-52.98	-13.00	39.98	90
3	5613.4	-48.93	5.42	12.65	Horizontal	-41.70	-13.00	28.70	135
4	7484.6	-56.35	6.70	13.85	Horizontal	-49.20	-13.00	36.20	315
5	9400.0	-55.34	7.01	14.75	Horizontal	-47.60	-13.00	34.60	225
6	11280.0	-53.34	7.48	15.95	Horizontal	-44.87	-13.00	31.87	270
7	13160.0	-51.34	7.51	16.55	Horizontal	-42.30	-13.00	29.30	0
8	15040.0	-50.21	8.24	15.35	Horizontal	-43.10	-13.00	30.10	45
9	16920.0	-46.68	8.41	14.95	Horizontal	-40.14	-13.00	27.14	90
10	18800.0	-	-	-	-	-	-	-	-

Note: 1. The other Spurious RF Radiated emissions level is no more than noise floor.  
 2. The worst emission was found in the antenna is Horizontal position.

## 6. Main Test Instruments

Name	Manufacturer	Type	Serial Number	Calibration Date	Expiration Date
Base Station Simulator	R&S	CMU200	118133	2019-05-19	2020-05-18
Base Station Simulator	R&S	CMW500	113824	2019-05-19	2020-05-18
Power Splitter	Hua Xiang	SHX-GF2-2-13	10120101	/	/
Spectrum Analyzer	Key sight	N9010A	MY50210259	2019-05-19	2020-05-18
Universal Radio Communication Tester	Key sight	E5515C	MY48367192	2019-05-19	2020-05-18
Signal Analyzer	R&S	FSV30	100815	2019-12-15	2020-12-14
Loop Antenna	SCHWARZBECK	FMZB1519	1519-047	2017-09-26	2020-09-25
Trilog Antenna	SCHWARZBECK	VUBL 9163	9163-201	2017-11-18	2020-11-17
Horn Antenna	R&S	HF907	100126	2018-07-07	2020-07-06
Horn Antenna	ETS-Lindgren	3160-09	00102643	2018-06-20	2020-06-19
Signal generator	R&S	SMB 100A	102594	2019-05-19	2020-05-18
Climatic Chamber	ESPEC	SU-242	93000506	2017-12-17	2020-12-16
Preamplifier	R&S	SCU18	102327	2019-05-19	2020-05-18
MOB COMMS DC SUPPLY	Keysight	66319D	MY43004105	2019-05-19	2020-05-18
RF Cable	Agilent	SMA 15cm	0001	2019-12-13	2020-6-12
Software	R&S	EMC32	9.26.0	/	/

\*\*\*\*\*END OF REPORT \*\*\*\*\*