

FCC Test Report

Product Name : peplink PEPWAVE Wireless Product
Brand Name : PEPWAVE / peplink
Model No. : Balance 20X Pro, BPL-021X-PRO-LTEA-Q-T-PRM
FCC ID : U8G-P1AX19

Applicant : PISMO LABS TECHNOLOGY LIMITED
Address : A8, 5/F, HK Spinners Industrial Building, Phase 6, 481
Castle Peak Road, Cheung Sha Wan, Hong Kong

Date of Receipt : Jul. 06, 2022
Issued Date : Sep. 28, 2022
Report No. : 2270136R-RFUSWL2V01-A
Report Version : V1.0



The test results relate only to the samples tested.

The test results shown in the test report are traceable to the national/international standard through the calibration of the equipment and evaluated measurement uncertainty herein.

This report must not be used to claim product endorsement by TAF or any agency of the government.

Measurement uncertainties evaluated for each testing system and associated connections are given here to provide the system information for reference. Compliance determinations do not take into account measurement uncertainties for each testing system, but are based on the results of the compliance measurement.

The test report shall not be reproduced except in full without the written approval of DEKRA Testing and Certification Co., Ltd.



Product Name : peplink PEPWAVE Wireless Product
Applicant : PISMO LABS TECHNOLOGY LIMITED
Address : A8, 5/F, HK Spinners Industrial Building, Phase 6, 481 Castle Peak Road, Cheung Sha Wan, Hong Kong
Manufacturer : PISMO LABS TECHNOLOGY LIMITED
Address : A8, 5/F, HK Spinners Industrial Building, Phase 6, 481 Castle Peak Road, Cheung Sha Wan, Hong Kong
Brand Name : PEPWAVE / peplink
Model No. : Balance 20X Pro, BPL-021X-PRO-LTEA-Q-T-PRM
FCC ID : U8G-P1AX19
EUT Voltage : DC 12V (adapter)
Applicable Standard : FCC CFR Title 47 Part 15 Subpart C Section 15.247
ANSI C63.10: 2013
Laboratory Name : DEKRA Testing and Certification Co., Ltd.
Hsin Chu Laboratory
Address : No.372-2, Sec. 4, Zhongxing Rd., Zhudong Township, Hsinchu County 310, Taiwan, R.O.C.
Test Result : Complied

Documented By : 

(Amelia Wu / Project Specialist)

Approved By : 

(Rueyyan Lin / Supervisor)

The test results relate only to the samples tested.

The test report shall not be reproduced except in full without the written approval of DEKRA Testing and Certification Co., Ltd.

Revision History

Version	Description	Issued Date
V1.0	Initial issue of report	Sep. 28, 2022

TABLE OF CONTENTS

Description	Page
1. General Information.....	6
1.1. EUT Description	6
1.2. Test Mode.....	8
1.3. Comments and Remarks.....	9
1.4. Tested System Details	10
1.5. Configuration of Tested System	10
1.6. EUT Operation of during Test	10
1.7. Test Facility	11
1.8. List of Test Equipment	12
1.9. Measurement Uncertainty	13
1.10. Duty Cycle.....	14
2. AC Power Line Conducted Emission.....	15
2.1. Test Setup	15
2.2. Test Limit	15
2.3. Test Procedure	15
2.4. Test Specification	15
2.5. Test Result of AC Power Line Conducted Emission	16
3. Maximum Conducted Output Power.....	18
3.1. Test Setup	18
3.2. Test Limit	18
3.3. Test Procedures	18
3.4. Test Specification	18
3.5. Test Result of Maximum Conducted Output Power.....	19
4. Radiated Emission	20
4.1. Test Setup	20
4.2. Test Limit	21
4.3. Test Procedure	21
4.4. Test Specification	21
4.5. Test Result of Radiated Emissions (30 MHz ~ 1 GHz).....	22
4.6. Test Result of Radiated Emissions (1 GHz ~ 10 th Harmonic).....	23
5. Antenna Port Conducted Emission.....	29
5.1. Test Setup	29
5.2. Test Limit	29
5.3. Test Procedure	29
5.4. Test Specification	29
5.5. Test Result of Antenna Port Conducted Emission.....	30
6. Radiated Emission Band Edge.....	42
6.1. Test Setup	42
6.2. Test Limit	42
6.3. Test Procedure	43
6.4. Test Specification	43
6.5. Test Result of Radiated Emission Band Edge.....	44
7. Occupied Bandwidth & DTS Bandwidth.....	56
7.1. Test Setup	56
7.2. Test Limit	56
7.3. Test Procedures	56
7.4. Test Specification	56
7.5. Test Result of Occupied Bandwidth	57
7.6. Test Result of DTS Bandwidth	59

8.	Maximum Power Spectral Density	61
8.1.	Test Setup	61
8.2.	Test Limit	61
8.3.	Test Procedures	61
8.4.	Test Specification	61
8.5.	Test Result of Maximum Power Spectral Density.....	62
Appendix A	64
<input type="checkbox"/>	Test Result of Radiated Emissions Co-location.....	64
Appendix B	66
<input type="checkbox"/>	Test Setup Photograph.....	66

1. General Information

1.1. EUT Description

Product Name	peplink PEPWAVE Wireless Product	
Brand Name	PEPWAVE / peplink	
Model No.	Balance 20X Pro, BPL-021X-PRO-LTEA-Q-T-PRM	
Frequency Range / Channel Number	IEEE 802.11b/g	2412 ~ 2462 MHz / 11 Channels
	IEEE 802.11n/ac/ax (20 MHz)	2412 ~ 2462 MHz / 11 Channels
	IEEE 802.11n/ac/ax (40 MHz)	2422 ~ 2452 MHz / 7 Channels
Type of Modulation	IEEE 802.11b	DSSS
	IEEE 802.11g/n/ac	OFDM
	IEEE 802.11ax	OFDMA
Data Rate	IEEE 802.11b	1, 2, 5.5, 11 Mbps
	IEEE 802.11g	6, 9, 12, 18, 24, 36, 48, 54 Mbps
	IEEE 802.11n	Support a subset of the combination of GI, MCS 0 ~ MCS 15 and bandwidth defined in 802.11n
	IEEE 802.11ac	Support a subset of the combination of GI, MCS 0 ~ MCS 9 and bandwidth defined in 802.11ac
	IEEE 802.11ax	Support a subset of the combination of GI, MCS 0 ~ MCS 11 and bandwidth defined in 802.11ax

Accessories Information				
No.	Equipment Name	Brand Name	Model No.	Rating
1	Adapter	DVE	DSA-36PFN-12 FUS 120300	INPUT: 100~240Vac, 50/60Hz, 1.0A OUTPUT: 12Vdc, 3.0A, 36.0W

The brand name/model number in the following table are all refer to the identical product.

Brand Name	Description
PEPWAVE	There is nothing different of two models, just for different marketing use.
peplink	
Model No.	
Balance 20X Pro	
BPL-021X-PRO-LTEA-Q-T-PRM	

From the above models, model: Balance 20X Pro was selected as representative model for the test and its data was recorded in this report.

Antenna Information				
Ant.	Brand Name	Model No.	Type	Antenna Gain (dBi)
0	Master Wave	98614PRSX000	Omni-directional	2.44
1	Master Wave	98614PRSX000	Omni-directional	2.44

For IEEE 802.11b/g/n/ac/ax Mode: (2TX, 2RX)

All of the antenna No. can be used as transmitting/receiving antennas, and them can transmit/receive signal simultaneously.

EUT Operational Condition	
Testing Voltage	AC 120V/60Hz

IEEE 802.11b/g & IEEE 802.11n/ac/ax (20 MHz)

Working Frequency of Each Channel							
Channel	Frequency	Channel	Frequency	Channel	Frequency	Channel	Frequency
01	2412 MHz	02	2417 MHz	03	2422 MHz	04	2427 MHz
05	2432 MHz	06	2437 MHz	07	2442 MHz	08	2447 MHz
09	2452 MHz	10	2457 MHz	11	2462 MHz	-	-

IEEE 802.11n/ac/ax (40 MHz)

Working Frequency of Each Channel							
Channel	Frequency	Channel	Frequency	Channel	Frequency	Channel	Frequency
03	2422 MHz	04	2427 MHz	05	2432 MHz	06	2437 MHz
07	2442 MHz	08	2447 MHz	09	2452 MHz	-	-

Note:

1. Regards to the frequency band operation; the lowest, middle and highest frequency of channel were selected to perform the test, and then shown on this report.
2. The above EUT information is declared by the manufacturer.

1.2. Test Mode

DEKRA has verified the construction and function in typical operation. The preliminary tests were performed in different data rate, and to find the worst condition, which was shown in this test report. The following table is the final test mode.

Test Mode	Mode 1: Transmit
-----------	------------------

Test Items	Test Mode	Modulation	Channel	Antenna	Result
AC Power Line Conducted Emission	Mode 1	11ax (40 MHz)	6	0+1	Pass
Maximum Conducted Output Power	Mode 1	11b	1/6/11	0+1	Pass
		11g	1/6/11	0+1	Pass
		11n (20 MHz)	1/6/11	0+1	Pass
		11ac (20 MHz)	1/6/11	0+1	Pass
		11ax (20 MHz)	1/6/11	0+1	Pass
		11n (40 MHz)	3/6/9	0+1	Pass
		11ac (40 MHz)	3/6/9	0+1	Pass
Radiated Emission Below 1 GHz	Mode 1	11ax (40 MHz)	6	0+1	Pass
Radiated Emission Above 1 GHz	Mode 1	11b	1/6/11	0+1	Pass
		11g	1/6/11	0+1	Pass
		11ax (20 MHz)	1/6/11	0+1	Pass
		11ax (40 MHz)	3/6/9	0+1	Pass
Antenna Port Conducted Emission	Mode 1	11b	1/6/11	0+1	Pass
		11g	1/6/11	0+1	Pass
		11ax (20 MHz)	1/6/11	0+1	Pass
		11ax (40 MHz)	3/6/9	0+1	Pass
Radiated Emission Band Edge	Mode 1	11b	1/6/11	0+1	Pass
		11g	1/6/11	0+1	Pass
		11ax (20 MHz)	1/6/11	0+1	Pass
		11ax (40 MHz)	3/6/9	0+1	Pass
Occupied Bandwidth & DTS Bandwidth	Mode 1	11b	1/6/11	0+1	Pass
		11g	1/6/11	0+1	Pass
		11ax (20 MHz)	1/6/11	0+1	Pass
		11ax (40 MHz)	3/6/9	0+1	Pass
Maximum Power Spectral Density	Mode 1	11b	1/6/11	0+1	Pass
		11g	1/6/11	0+1	Pass
		11ax (20 MHz)	1/6/11	0+1	Pass
		11ax (40 MHz)	3/6/9	0+1	Pass

Note:

- Determining compliance shall be based on the results of the compliance measurement, not taking into account measurement instrumentation uncertainty.

2. The worst case of data rate for 802.11b is 1 Mbps, for 802.11g is 6 Mbps, for 802.11ax (20 MHz)/802.11ax (40 MHz) are MCS 0, Nss1.
3. The modulation and bandwidth are similar for 802.11n mode for HT20/HT40, 802.11ac mode for VHT20/VHT40 and 802.11ax mode for HE20/HE40, therefore investigated worst case to representative mode in test report. (Please refer to the test result of conducted output power for detail.)
4. For radiated emission below 1 GHz and AC power line conducted emission have performed all modes of operation were investigated and the worst-case emissions are reported.
5. The EUT could be applied with 1. WiFi 2.4 GHz function + WiFi 5 GHz function + WWAN WCDMA function and 2. WiFi 2.4 GHz function + WiFi 5 GHz function + WWAN LTE function; therefore Co-location Maximum Permissible Exposure (Please refer to DEKRA Report No.: 2270136R-RFUSMPEV02-A) and Radiated Emission Co-location (Please refer to Appendix A) tests are added for simultaneously transmit with 1. WiFi 2.4 GHz function + WiFi 5 GHz function + WWAN WCDMA function and 2. WiFi 2.4 GHz function + WiFi 5 GHz function + WWAN LTE function.
6. The EUT contains a WWAN module (brand name: Telit, model: LN920A12-WW, FCC ID: RI7LN920).

1.3. Comments and Remarks

The product specification and testing instructions for the EUT declared in the report are provided by the manufacturer who will take all responsibilities for the accuracy.

1.4. Tested System Details

The types for all equipment, plus descriptions of all cables used in the tested system.

Product		Manufacturer	Model No.	Serial No.
1	Notebook	Lenove	Lenovo Ideapad 320	PF0SXXY1

1.5. Configuration of Tested System

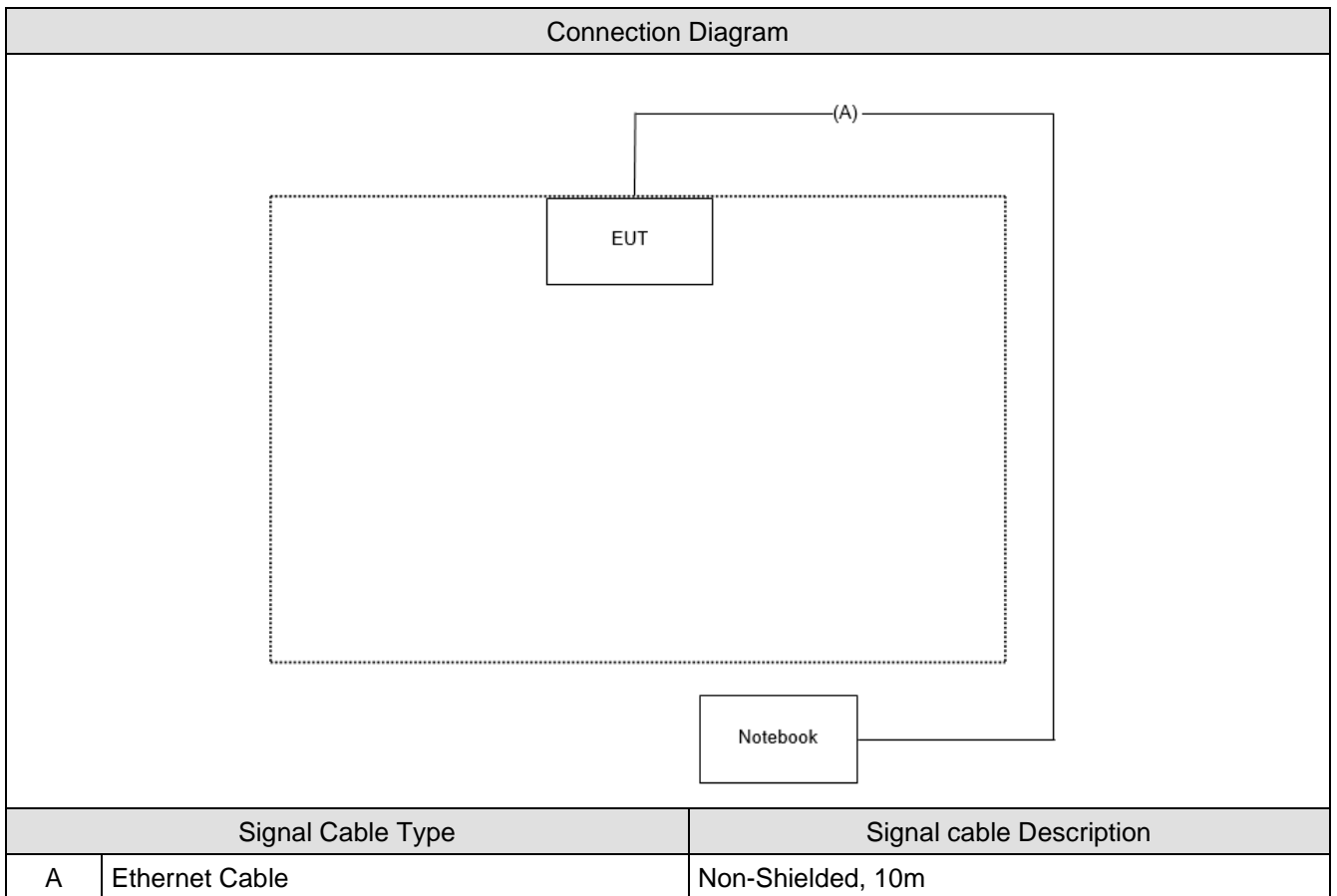

1.6. EUT Operation of during Test

1	Execute control command by software "QSPR v5.0-00197".
2	Configure the test mode, the test channel, and the data rate.
3	Press "Start TX" to start the continuous transmitting.
4	Verify that the EUT works properly.

1.7. Test Facility

Ambient conditions in the laboratory:

Items	Test Item	Actually	Tested by	Test Date	Test Site
Temperature (°C)	AC Power Line Conducted Emission	22.8	Ling Chen	2022/08/04	HC-SR02
Humidity (%RH)		62			
Temperature (°C)	Maximum Conducted Output Power	23 ~ 25	Clemens Fang	2022/07/26 ~ 2022/08/09	HC-SR12
Humidity (%RH)		58 ~ 63			
Temperature (°C)	Radiated Emission	22.5 ~ 23.8	Gary Liao Ling Chen	2022/07/19 ~ 2022/07/26	HC-CB04
Humidity (%RH)		56 ~ 58			
Temperature (°C)	Antenna Port Conducted Emission	25	Clemens Fang	2022/07/28	HC-SR12
Humidity (%RH)		57			
Temperature (°C)	Radiated Emission Band Edge	21.5 ~ 22.5	Gary Liao	2022/07/20 ~ 2022/07/21	HC-CB04
Humidity (%RH)		55 ~ 57			
Temperature (°C)	Occupied Bandwidth & DTS Bandwidth	25	Clemens Fang	2022/07/28	HC-SR12
Humidity (%RH)		57			
Temperature (°C)	Maximum Power Spectral Density	25	Clemens Fang	2022/07/28	HC-SR12
Humidity (%RH)		57			

Note: Test site information refers to Laboratory Information.

USA : **FCC Registration Number: TW3024**
Canada : **CAB identifier : TW3024**

The address and introduction of DEKRA Testing and Certification Co., Ltd. laboratories can be founded in our Web site: <http://www.dekra.com.tw>

If you have any comments, please don't hesitate to contact us. Our test sites as below:

Test Laboratory	DEKRA Testing and Certification Co., Ltd.
Address	1. No.372-2, Sec. 4, Zhongxing Rd., Zhudong Township, Hsinchu County 31061, Taiwan, R.O.C. 2. No.372, Sec. 4, Zhongxing Rd., Zhudong Township, Hsinchu County 31061, Taiwan, R.O.C.
Phone number	1. +886-3-582-8001 2. +886-3-582-8001
Fax number	1. +886-3-582-8958 2. +886-3-582-8958
E mail address	info.tw@dekra.com
Website	http://www.dekra.com.tw
Note: Test site number for address 1 includes HC-SR02. Test site number for address 2 includes HC-CB02, HC-CB03, HC-CB04, SR10-H and HC-SR12.	

1.8. List of Test Equipment

HC-SR02

Instrument	Manufacturer	Model No.	Serial No.	Cal. Date	Next Cal. Date
Artificial Mains Network	R&S	ENV4200	848411/010	2021/12/27	2022/12/26
EMI Test Receiver	R&S	ESR3	102608	2022/05/30	2023/05/29
LISN	R&S	ENV216	100092	2022/04/29	2023/04/28
Coaxial Cable(9 m)	Harbour	RG-400	HC-SR02	2021/08/15	2022/08/14
DEKRA Testing System	DEKRA	Version 2.0	HC-SR02	N/A	N/A

HC-SR12

Instrument	Manufacturer	Model No.	Serial No.	Cal. Date	Next Cal. Date
High Speed Peak Power Meter Dual Input	Anritsu	ML2496A	1602004	2021/11/12	2022/11/11
Pulse Power Sensor	Anritsu	MA2411B	1531043	2021/11/12	2022/11/11
EXA Signal Analyzer	Keysight	N9010A	MY51440132	2022/01/07	2023/01/06
Pulse Power Sensor	Anritsu	MA2411B	1531044	2021/11/12	2022/11/11
Power Meter	Keysight	8990B	MY51000248	2022/05/06	2023/05/05
Power Sensor	Keysight	N1923A	MY57240005	2022/05/06	2023/05/05
Signal and Spectrum Analyzer	R&S	FSVA40	101435	2022/05/30	2023/05/29

HC-CB04

Instrument	Manufacturer	Model No.	Serial No.	Cal. Date	Next Cal. Date
Signal Analyzer	R&S	FSVA40	101455	2021/10/22	2022/10/21
EXA Signal Analyzer	Keysight	N9010A	MY51440132	2022/01/07	2023/01/06
Trilog Broadband Antenna	Schwarzbeck	VULB 9168	1209	2022/06/14	2023/06/13
Horn Antenna	Schwarzbeck	BBHA 9120D	639	2022/05/06	2023/05/05
Horn Antenna	Schwarzbeck	BBHA 9170	203	2022/02/23	2023/02/22
Pre-Amplifier	EMCI	EMC01820I	980365	2022/04/15	2023/04/14
Pre-Amplifier	EMEC	EM01G18GA	060741	2022/05/06	2023/05/05
Pre-Amplifier	DEKRA	AP-400C	201801231	2021/12/24	2022/12/23
Coaxial Cable(10m)	Suhner	SF102_SF104	HC-CB04	2021/08/09	2022/08/08
Coaxial Cable(3m)	Suhner,Rosnol	SF102_UP0264	HC-CB04_1	2021/08/17	2022/08/18
EMI Test Receiver	R&S	ESR7	102260	2021/12/22	2022/12/21
Magnetic Loop Antenna	Teseq	HLA 6121	44287	2021/09/06	2022/09/05
Radiated Software	AUDIX	e3 V9	HC-CB04_1	N/A	N/A

Note: All equipment upon which need to calibrated are with calibration period of 1 year.

1.9. Measurement Uncertainty

Uncertainties have been calculated according to the DEKRA internal document with the emissions test results be included in the report. The measurement uncertainties given below are based on a 95% confidence level (based on a coverage factor (k=2)).

Test Item	Uncertainty
AC Power Line Conducted Emission	± 2.10 dB
Maximum Conducted Output Power	± 1.16 dB
Radiated Emission	± 3.25 dB below 1 GHz ± 3.32 dB above 1 GHz
Antenna Port Conducted Emission	± 1.60 dB
Radiated Emission Band Edge	± 3.32 dB above 1GHz
DTS Bandwidth	± 282.55 Hz
Occupied Bandwidth	± 282.55 Hz
Maximum Power Spectral Density	± 1.60 dB

1.10. Duty Cycle

Modulation	On Times (ms)	On+Off Times (ms)	Duty Cycle (%)	Duty Factor (dB)	1/T Minimum VBW (kHz)
802.11b	0.640	1.235	51.82	2.855	1.563
802.11g	1.425	1.545	92.23	0.351	0.702
802.11ax (20 MHz)	5.420	5.680	95.42	0.203	0.185
802.11ax (40 MHz)	5.440	5.700	95.44	0.203	0.184

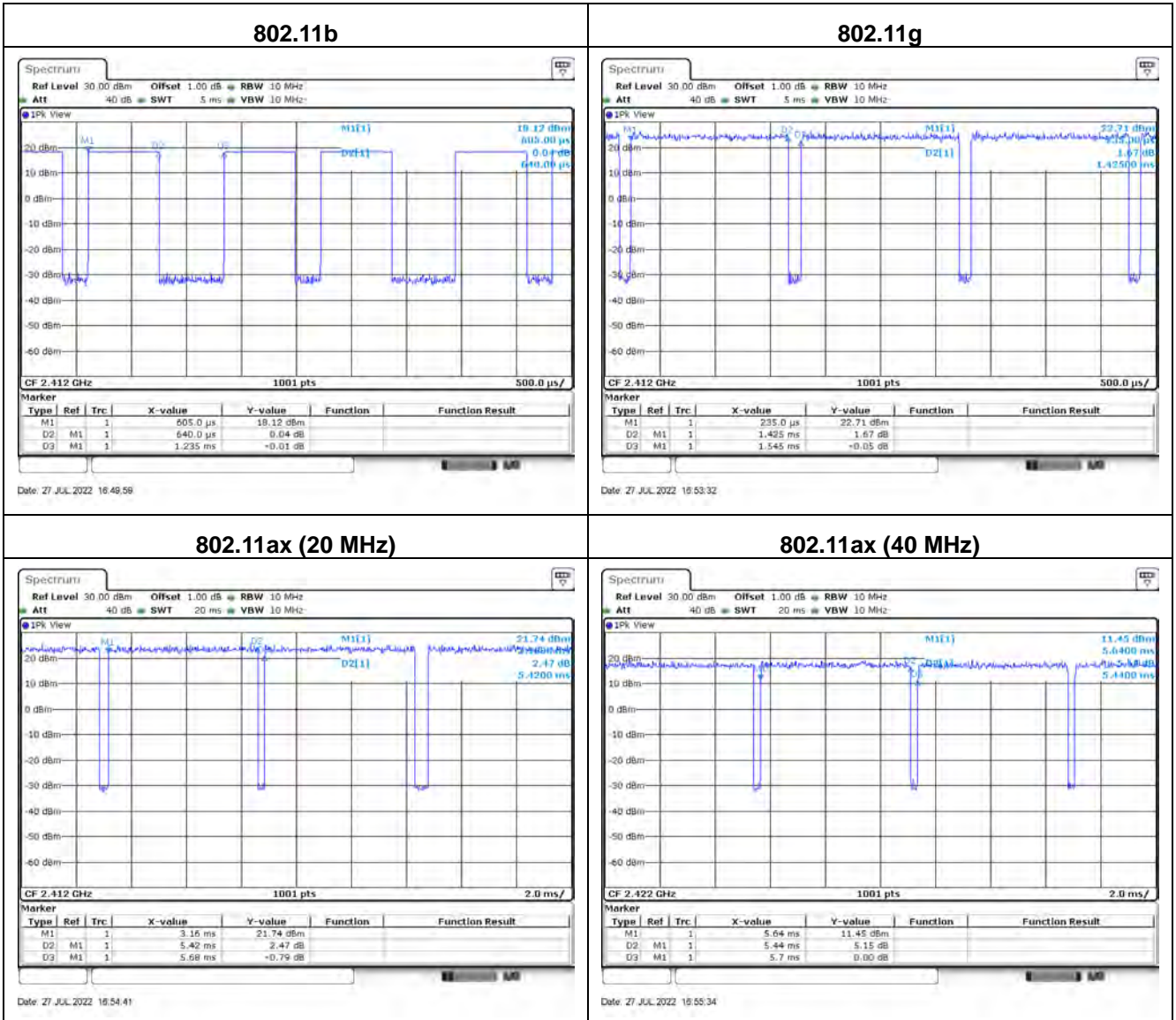

2. AC Power Line Conducted Emission

2.1. Test Setup

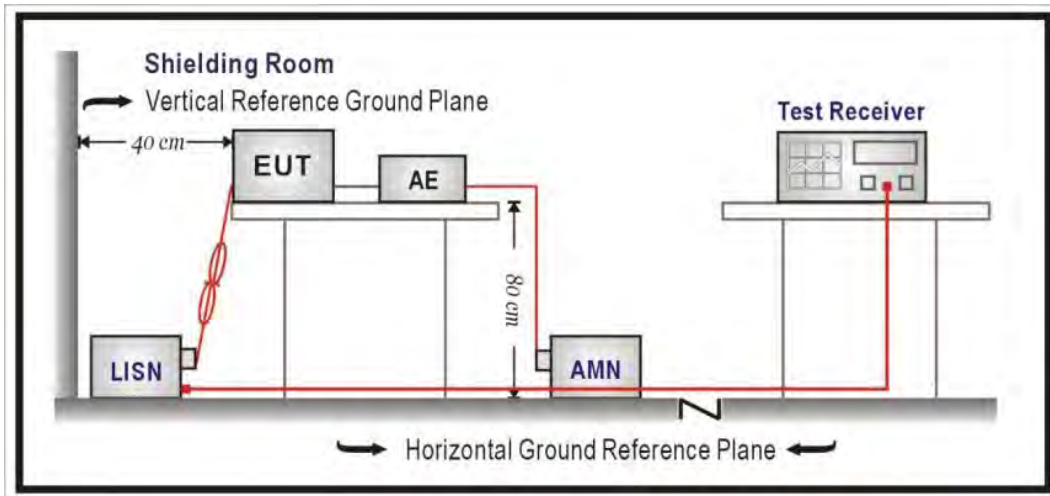

2.2. Test Limit

Frequency (MHz)	QP (dBuV)	AV (dBuV)
0.15 - 0.50	66 - 56	56 - 46
0.50 - 5.0	56	46
5.0 - 30	60	50

Remarks: In the above table, the tighter limit applies at the band edges.

2.3. Test Procedure

The EUT and simulators are connected to the main power through a line impedance stabilization network (L.I.S.N.). This provides a 50 ohm /50 uH coupling impedance for the measuring equipment. The peripheral devices are also connected to the main power through a LISN that provides a 50 ohm/50 uH coupling impedance with 50 ohm termination. (Please refer to the block diagram of the test setup and photographs.)

Both sides of A.C. line are checked for maximum conducted interference. In order to find the maximum emission, the relative positions of equipment and all of the interface cables must be changed according to ANSI C63.10: 2013 on conducted measurement.

AC Power Line Conducted Emissions were investigated over the frequency range from 0.15 MHz to 30 MHz using a receiver bandwidth of 9 kHz.

2.4. Test Specification

According to FCC Part 15 Subpart C Paragraph 15.247.

2.5. Test Result of AC Power Line Conducted Emission

Test Mode	Mode 1: Transmit	Phase	Line
Test Condition	802.11ax (40MHz) / Ant. 0 + Ant. 1 / 2437 MHz		

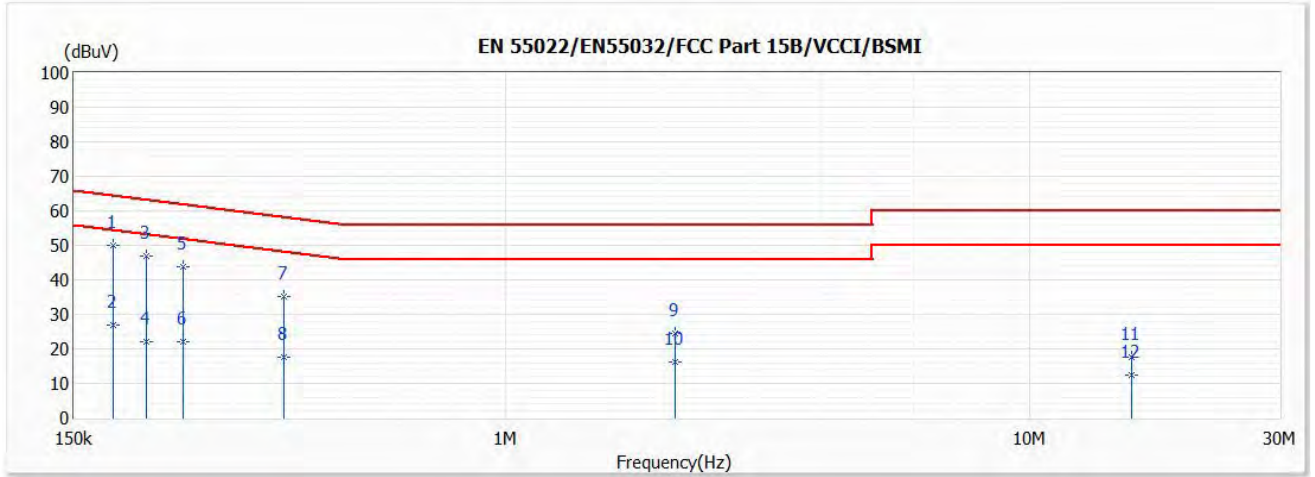

No	Frequency (MHz)	Emission Level (dBuV)	Limit (dBuV)	Margin (dB)	Reading Level (dBuV)	Correct Factor (dB)	Detector Type
*1	0.178	50.02	64.57	-14.55	40.41	9.61	QP
2	0.178	26.87	54.57	-27.70	17.26	9.61	AV
3	0.207	46.77	63.34	-16.57	37.16	9.61	QP
4	0.207	22.12	53.34	-31.22	12.51	9.61	AV
5	0.242	43.77	62.03	-18.26	34.15	9.62	QP
6	0.242	22.22	52.03	-29.81	12.60	9.62	AV
7	0.378	35.27	58.32	-23.05	25.63	9.64	QP
8	0.378	17.53	48.32	-30.79	7.89	9.64	AV
9	2.107	24.38	56.00	-31.62	14.63	9.75	QP
10	2.107	16.29	46.00	-29.71	6.54	9.75	AV
11	15.649	17.74	60.00	-42.26	7.49	10.25	QP
12	15.649	12.48	50.00	-37.52	2.23	10.25	AV

Remark:

1. "*" means this data is the worst emission level.
2. Emission Level = Reading Level + Correct Factor (Correct Factor = LISN Insertion Loss + Cable Loss).
3. Margin = Emission Level - Limit.

Test Mode	Mode 1: Transmit	Phase	Neutral
Test Condition	802.11ax (40MHz) / Ant. 0 + Ant. 1 / 2437 MHz		

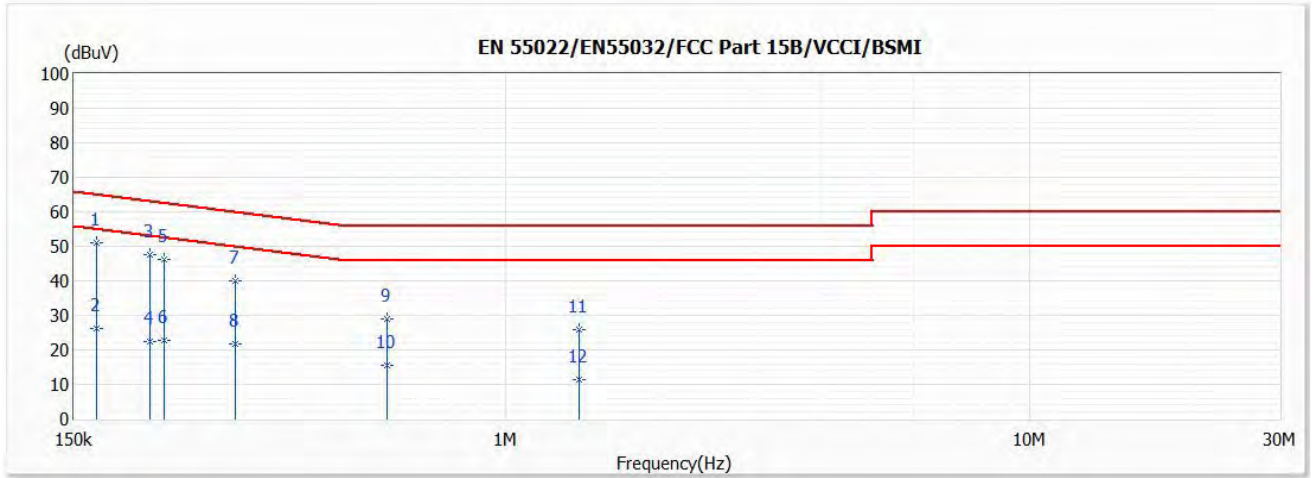

No	Frequency (MHz)	Emission Level (dBuV)	Limit (dBuV)	Margin (dB)	Reading Level (dBuV)	Correct Factor (dB)	Detector Type
*1	0.165	51.15	65.20	-14.05	41.53	9.62	QP
2	0.165	26.36	55.20	-28.84	16.74	9.62	AV
3	0.210	47.54	63.21	-15.67	37.92	9.62	QP
4	0.210	22.58	53.21	-30.63	12.96	9.62	AV
5	0.223	46.08	62.72	-16.64	36.46	9.62	QP
6	0.223	22.80	52.72	-29.92	13.18	9.62	AV
7	0.305	39.84	60.10	-20.26	30.22	9.62	QP
8	0.305	21.72	50.10	-28.38	12.10	9.62	AV
9	0.593	28.83	56.00	-27.17	19.17	9.66	QP
10	0.593	15.36	46.00	-30.64	5.70	9.66	AV
11	1.379	25.74	56.00	-30.26	16.02	9.72	QP
12	1.379	11.46	46.00	-34.54	1.74	9.72	AV

Remark:

1. "*" means this data is the worst emission level.
2. Emission Level = Reading Level + Correct Factor (Correct Factor = LISN Insertion Loss + Cable Loss).
3. Margin = Emission Level - Limit.

3. Maximum Conducted Output Power

3.1. Test Setup

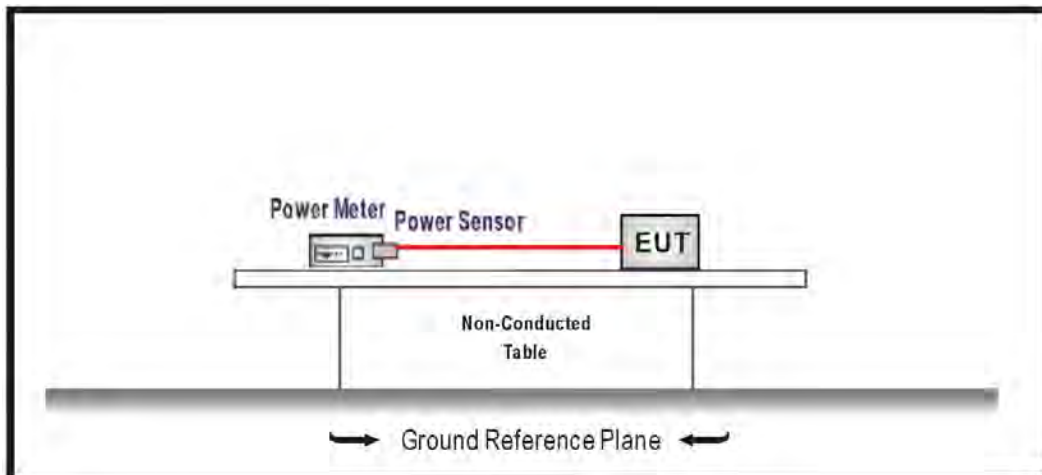

3.2. Test Limit

The maximum conducted output power shall be less 30 dBm (1 Watt).

3.3. Test Procedures

The EUT was setup according to ANSI C63.10: 2013; tested according to DTS test procedure of KDB 558074 D01 v05r02 for compliance to FCC 47CFR 15.247 requirements.

3.4. Test Specification

According to FCC Part 15 Subpart C Paragraph 15.247.

3.5. Test Result of Maximum Conducted Output Power

Modulation	Channel	Frequency (MHz)	Maximum Conducted Output Power (dBm)			Limit (dBm)	Result
			Ant. 0	Ant. 1	Total		
802.11b	1	2412	19.80	19.52	22.67	≤ 30.00	Pass
	6	2437	21.98	21.89	24.95	≤ 30.00	Pass
	11	2462	22.93	22.62	25.79	≤ 30.00	Pass
802.11g	1	2412	22.52	22.18	25.36	≤ 30.00	Pass
	6	2437	22.94	22.61	25.79	≤ 30.00	Pass
	11	2462	21.53	21.22	24.39	≤ 30.00	Pass
802.11n (20 MHz)	1	2412	19.48	19.42	22.46	≤ 30.00	Pass
	6	2437	22.73	22.22	25.49	≤ 30.00	Pass
	11	2462	20.12	19.88	23.01	≤ 30.00	Pass
802.11ac (20 MHz)	1	2412	19.53	19.44	22.50	≤ 30.00	Pass
	6	2437	22.77	22.25	25.53	≤ 30.00	Pass
	11	2462	20.20	19.93	23.08	≤ 30.00	Pass
802.11ax (20 MHz)	1	2412	19.62	19.51	22.58	≤ 30.00	Pass
	6	2437	22.78	22.29	25.55	≤ 30.00	Pass
	11	2462	20.32	20.04	23.19	≤ 30.00	Pass
802.11n (40 MHz)	3	2422	17.03	16.59	19.83	≤ 30.00	Pass
	6	2437	18.66	18.35	21.52	≤ 30.00	Pass
	9	2452	15.82	15.68	18.76	≤ 30.00	Pass
802.11ac (40 MHz)	3	2422	17.06	16.65	19.87	≤ 30.00	Pass
	6	2437	18.72	18.40	21.57	≤ 30.00	Pass
	9	2452	15.88	15.74	18.82	≤ 30.00	Pass
802.11ax (40 MHz)	3	2422	17.13	16.71	19.94	≤ 30.00	Pass
	6	2437	18.73	18.49	21.62	≤ 30.00	Pass
	9	2452	15.94	15.85	18.91	≤ 30.00	Pass

4. Radiated Emission

4.1. Test Setup

9 kHz ~ 30 MHz

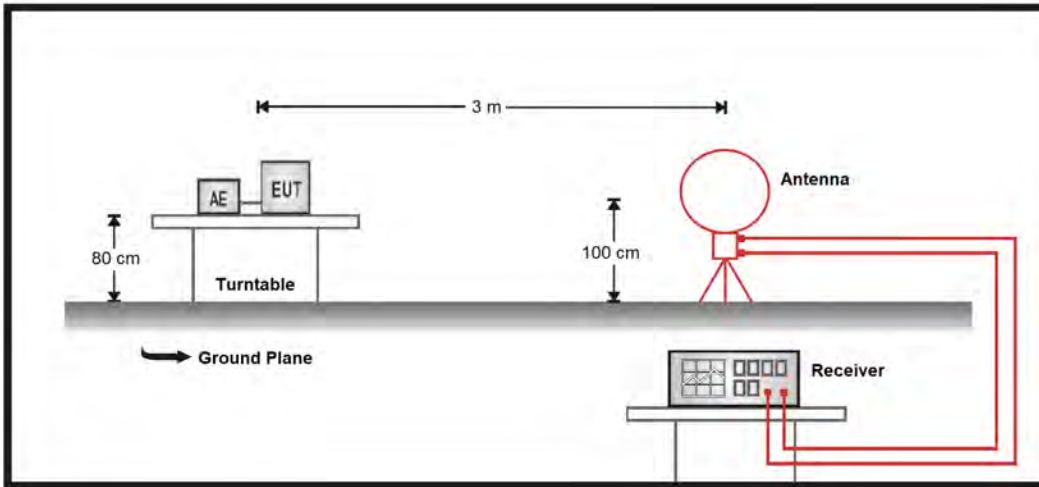

30 MHz ~ 1 GHz

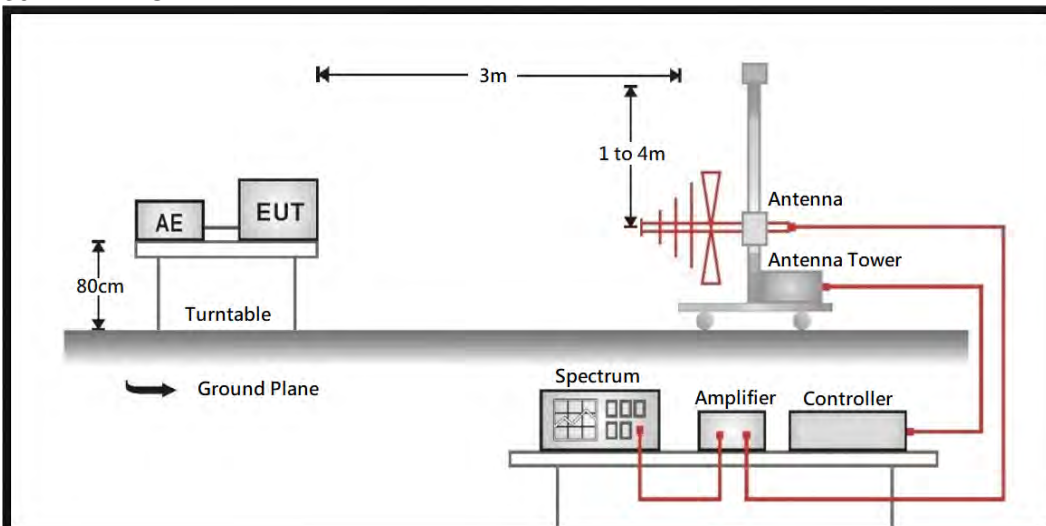

Above 1 GHz

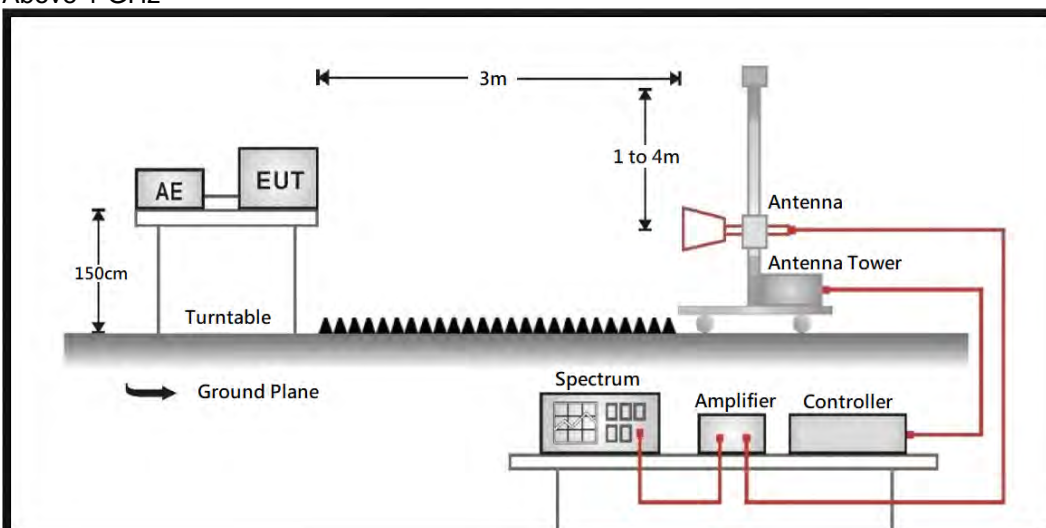

4.2. Test Limit

Emissions radiated outside of the specified frequency bands, except for harmonics, shall be attenuated by at least 30dB below the level of the fundamental or to the general radiated emission limit in paragraph 15.209, whichever is the lesser attenuation.

Frequency (MHz)	Field strength (uV/m)	Field strength (dBuV/m)	Measurement distance (m)
0.009 – 0.490	2400/F(kHz)	20 log (2400/F(kHz))	300
0.490 – 1.705	24000/F(kHz)	20 log (24000/F(kHz))	30
1.705 - 30	30	29.5	30
30 - 88	100	40	3
88 - 216	150	43.5	3
216 - 960	200	46	3
Above 960	500	54	3

Remarks:

1. Field strength (dBuV/m) = 20 log Field strength (uV/m)
2. In the Above Table, the tighter limit applies at the band edges.
3. Distance refers to the distance in meters between the measuring instrument antenna and the closed point of any part of the device or system

4.3. Test Procedure

The EUT was setup according to ANSI C63.10: 2013 and tested according to DTS test procedure of KDB 558074 D01V05r02 for compliance to FCC 47CFR 15.247 requirements.

The EUT and its simulators are placed on a turn table which is 0.8 or 1.5 meter above ground. The turn table can rotate 360 degrees to determine the position of the maximum emission level.

The antenna can move up and down between 1 meter and 4 meters to find out the maximum emission level.

Both horizontal and vertical polarization of the antenna are set on measurement. In order to find the maximum emission, all of the interface cables must be manipulated according to ANSI C63.10: 2013 on radiated measurement.

On any frequency or frequencies from 9 kHz(include The the lowest oscillator frequency generated within the device up to the 10th harmonic) to 1000 MHz, the limit shown are based on measuring equipment employing a quasi-peak detector function and on any frequency or frequencies above 1000 MHz the radiated limit shown are based upon the use of measurement instrumentation employing an average detector function. When average radiated emission measurement are included emission measurement below 1000 MHz, there also is a limit on the radio frequency emissions, as measured using instrumentation with a peak detector function, corresponding to 20 dB above the maximum permitted average limit.

The bandwidth below 1 GHz setting on the field strength meter is 120 kHz and above 1 GHz is 1 MHz.

4.4. Test Specification

According to FCC Part 15 Subpart C Paragraph 15.247.

4.5. Test Result of Radiated Emissions (30 MHz ~ 1 GHz)



4.6. Test Result of Radiated Emissions (1 GHz ~ 10th Harmonic)

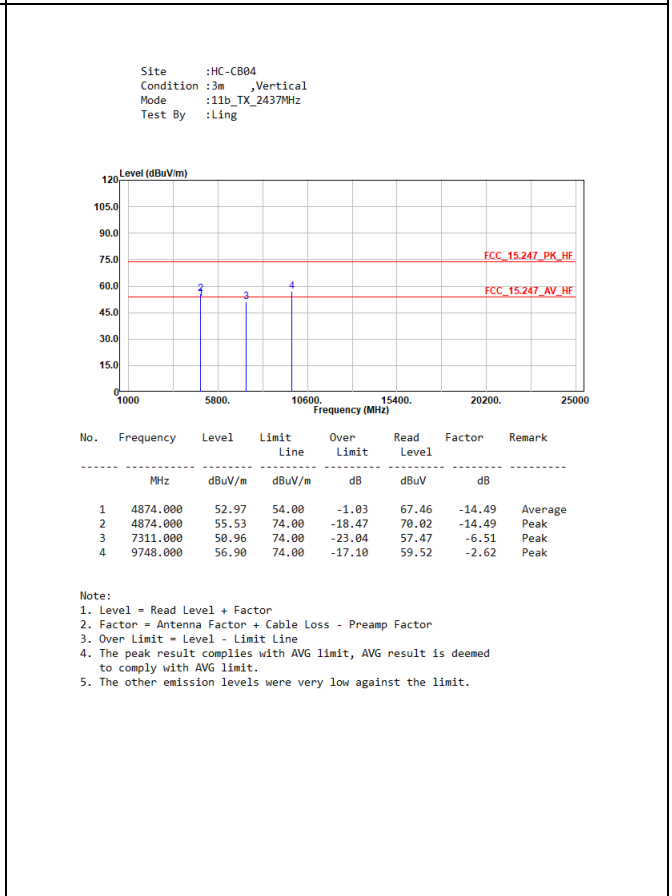
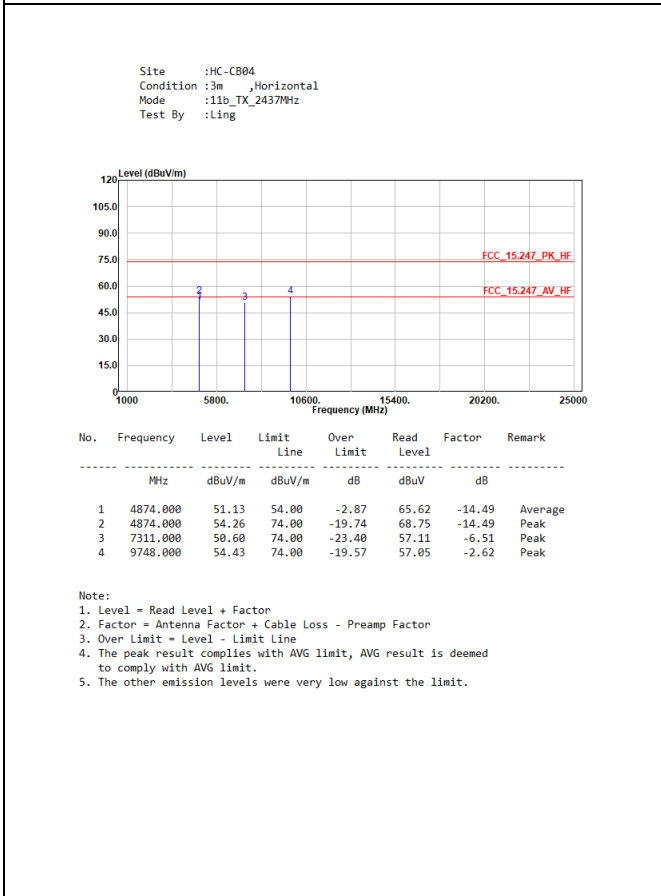
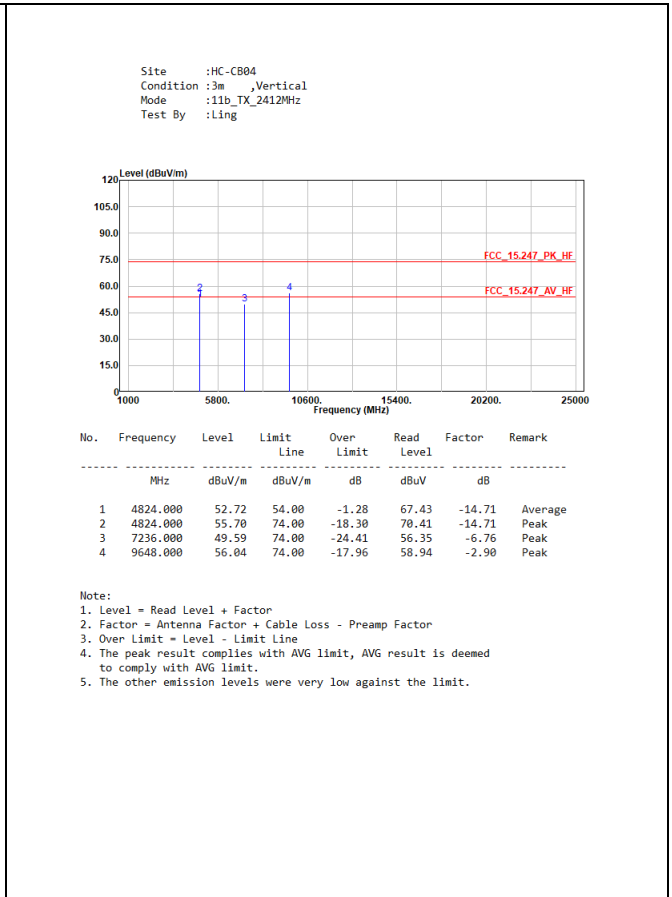
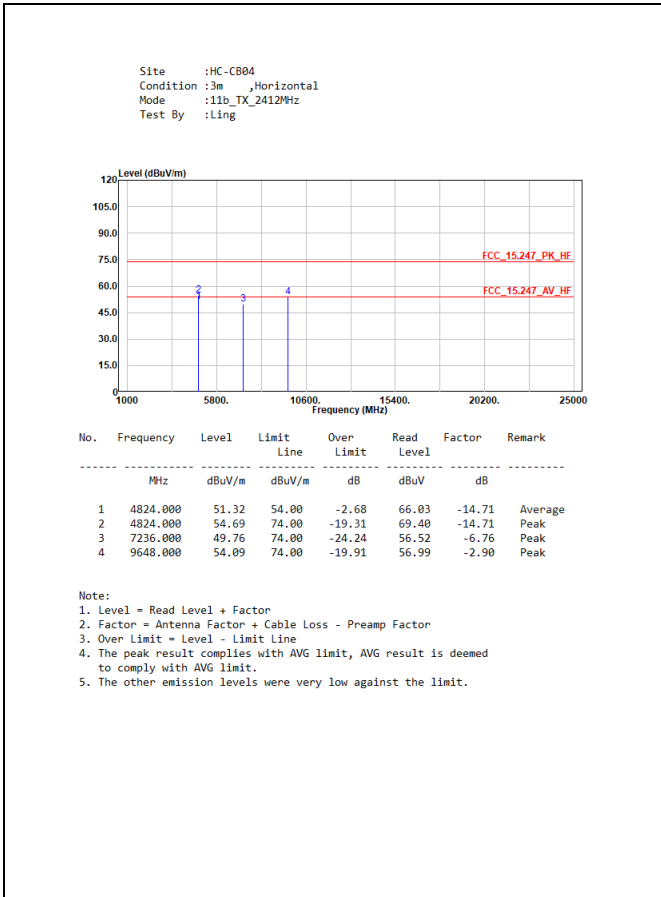

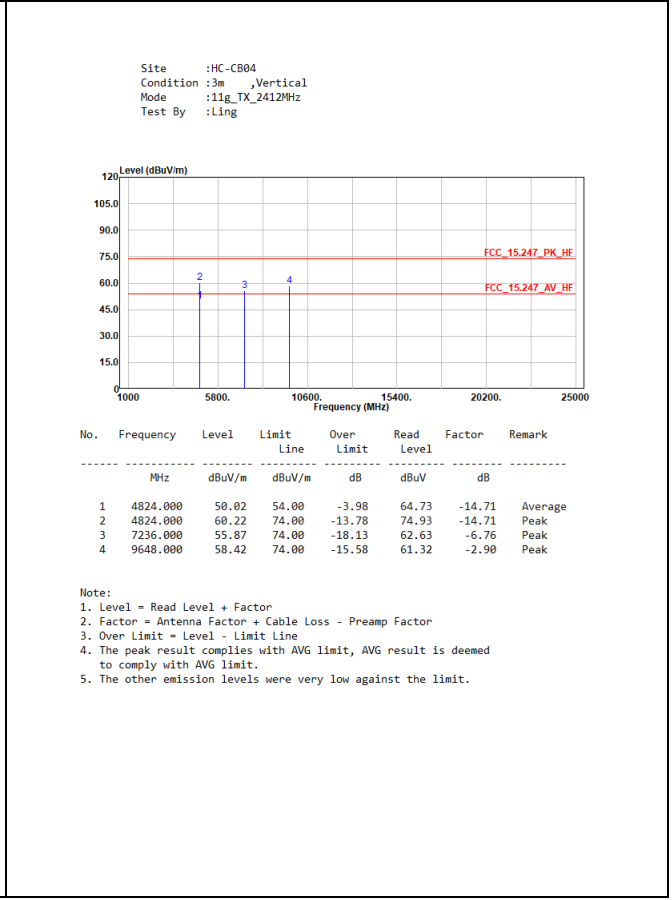
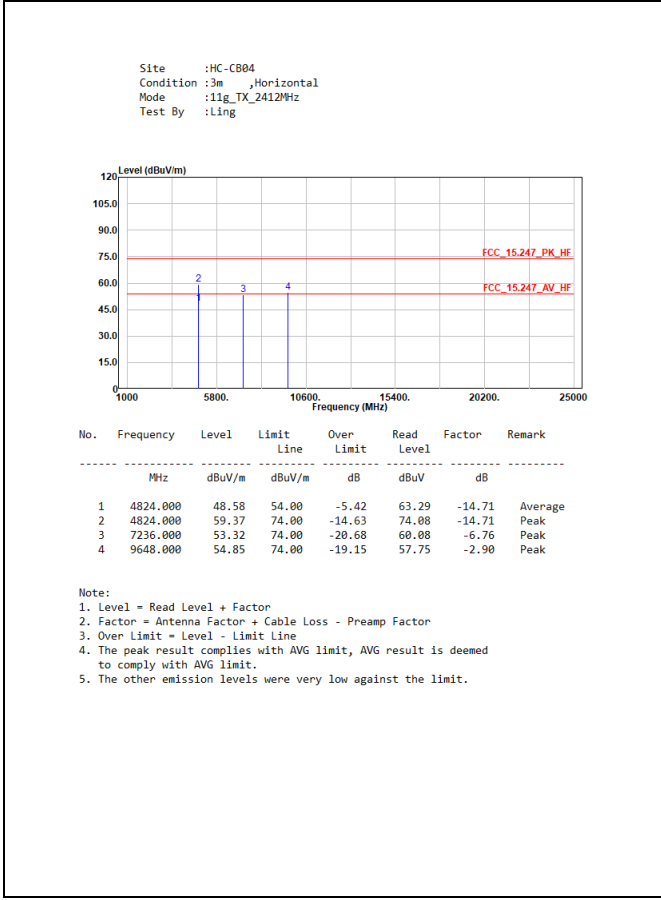
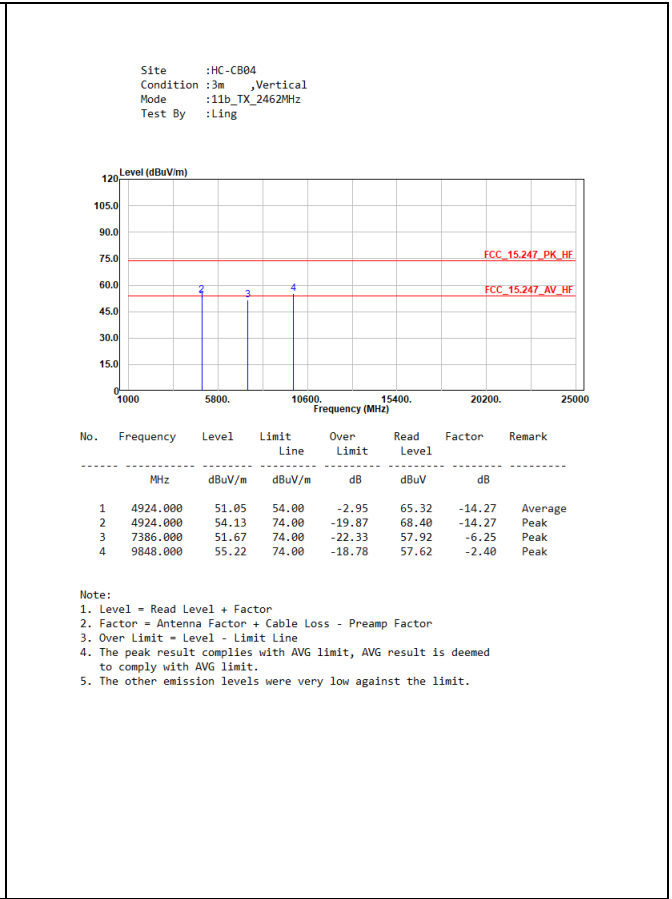
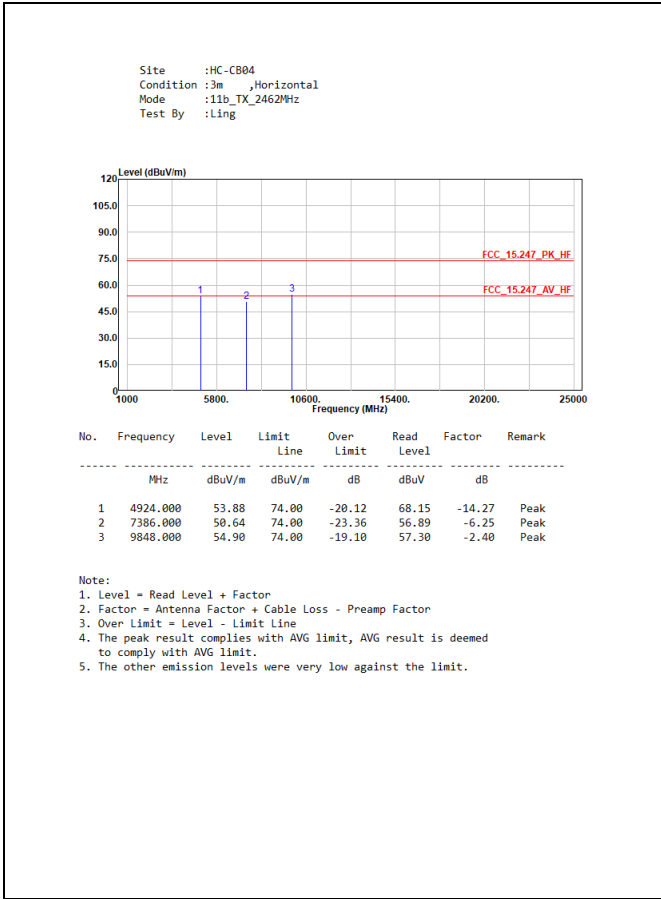

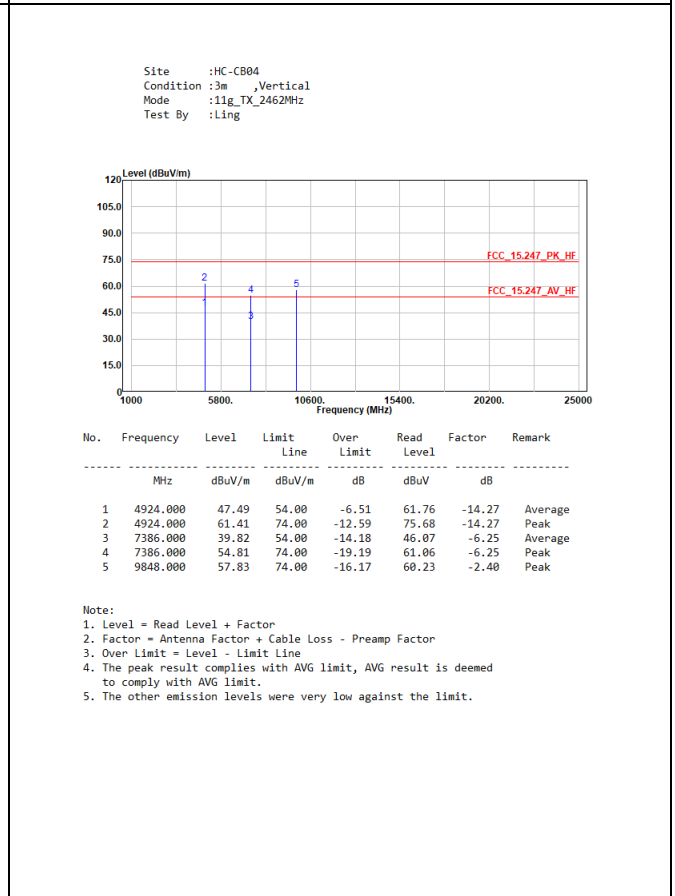
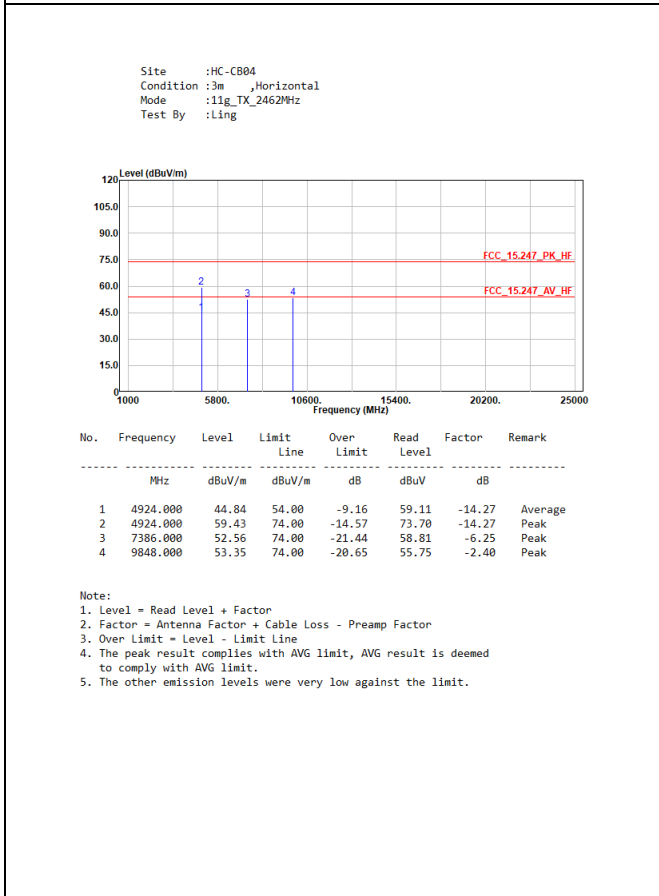
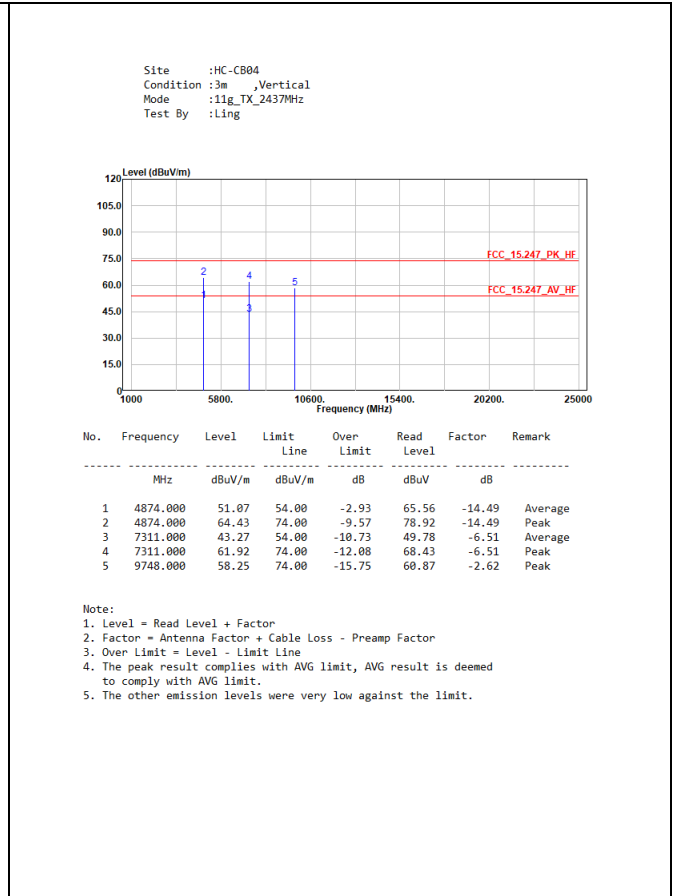
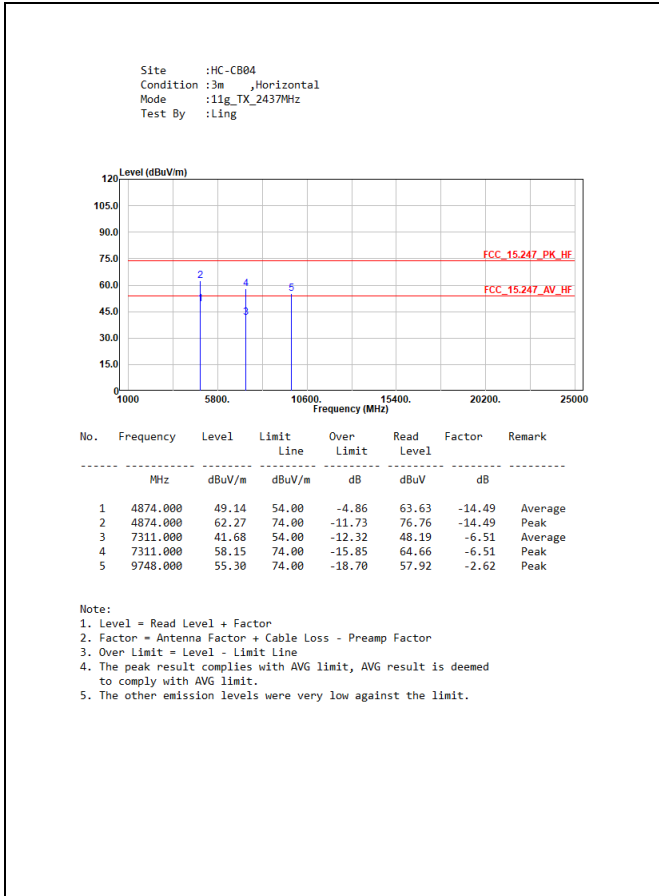

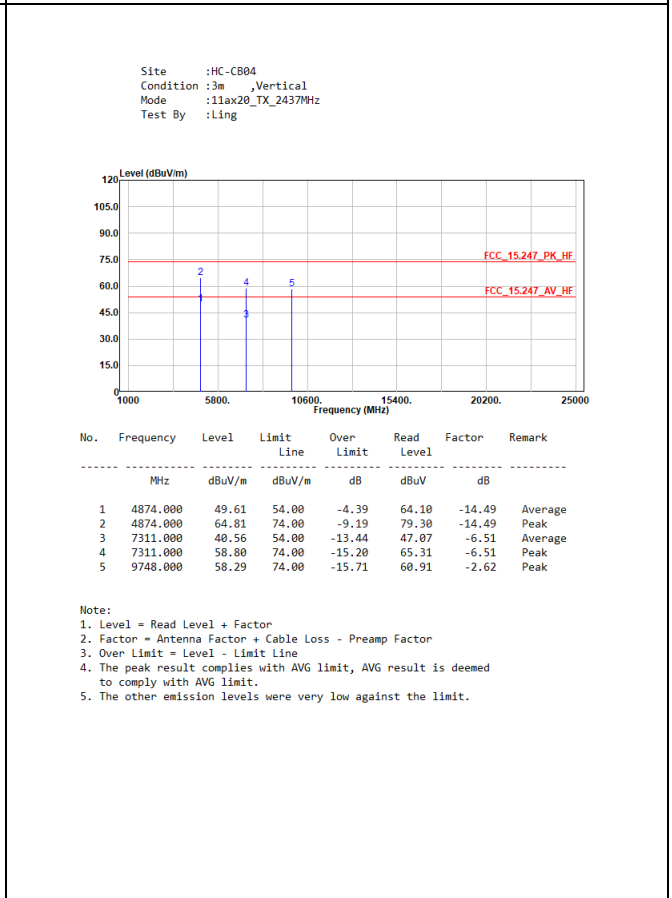
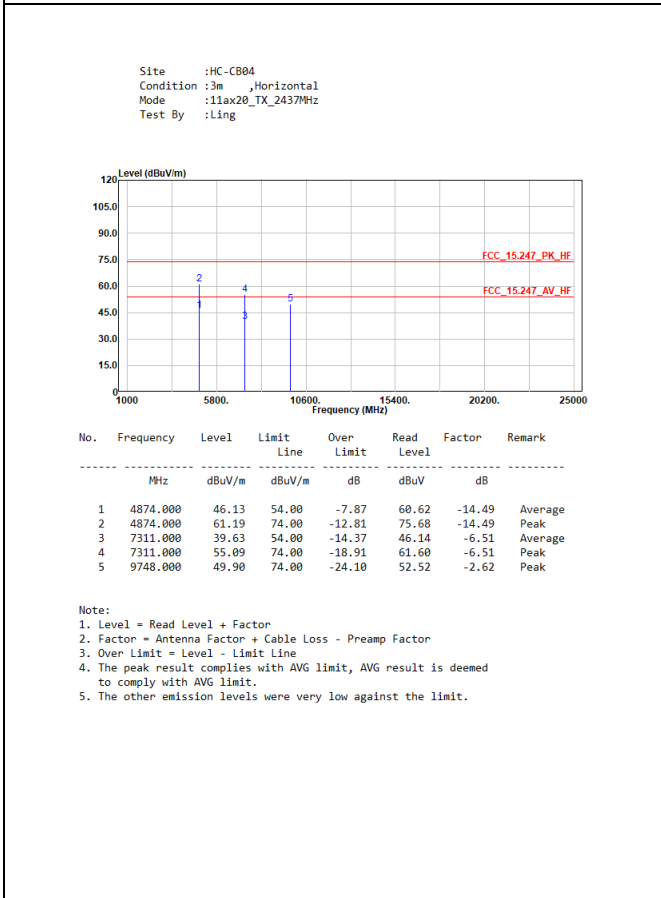
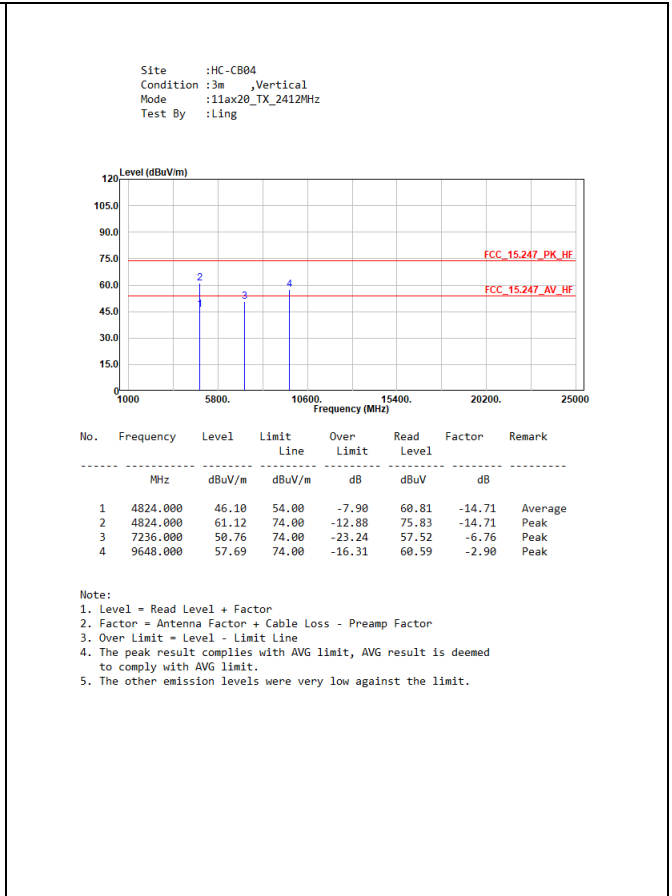
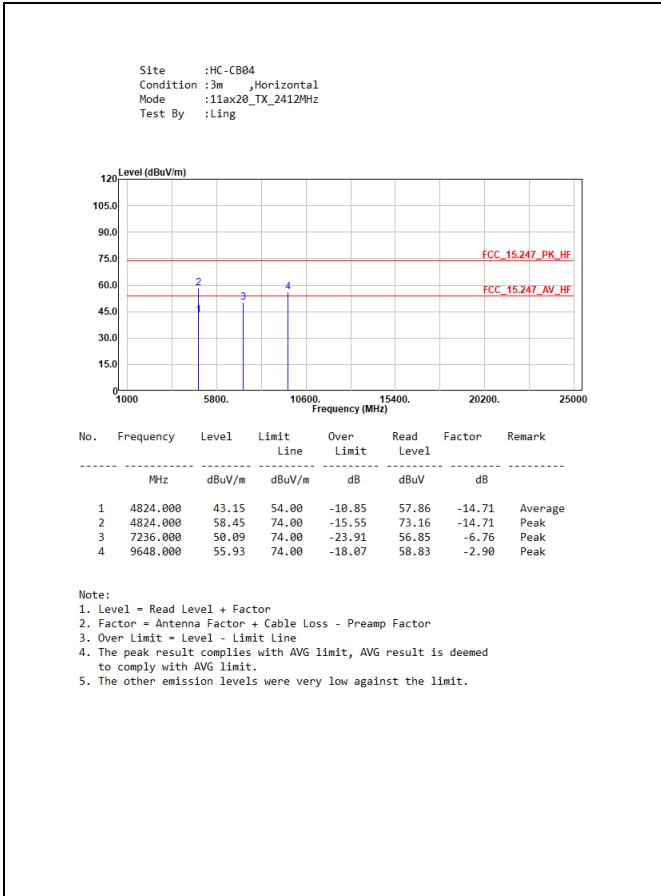

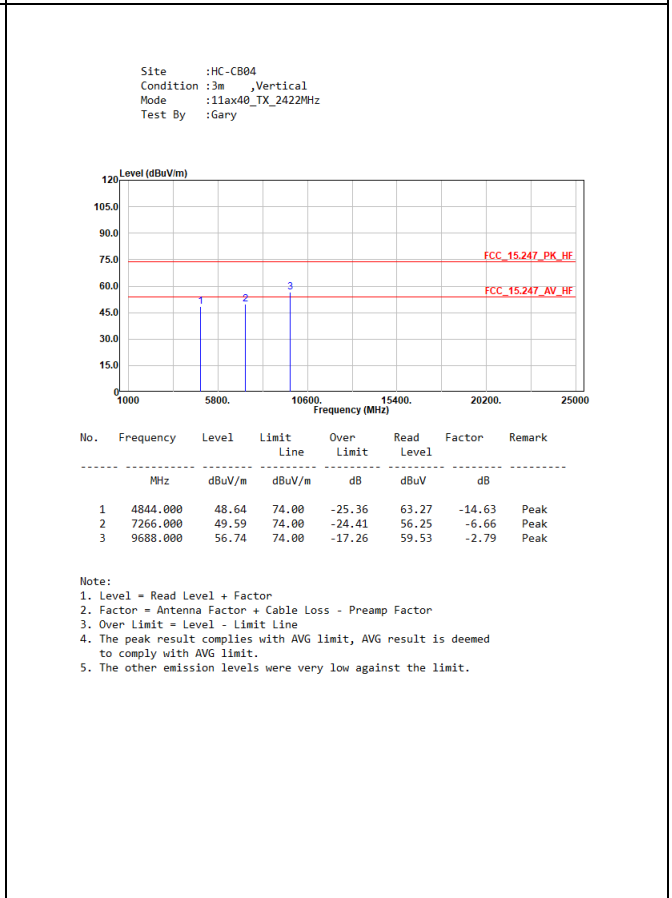
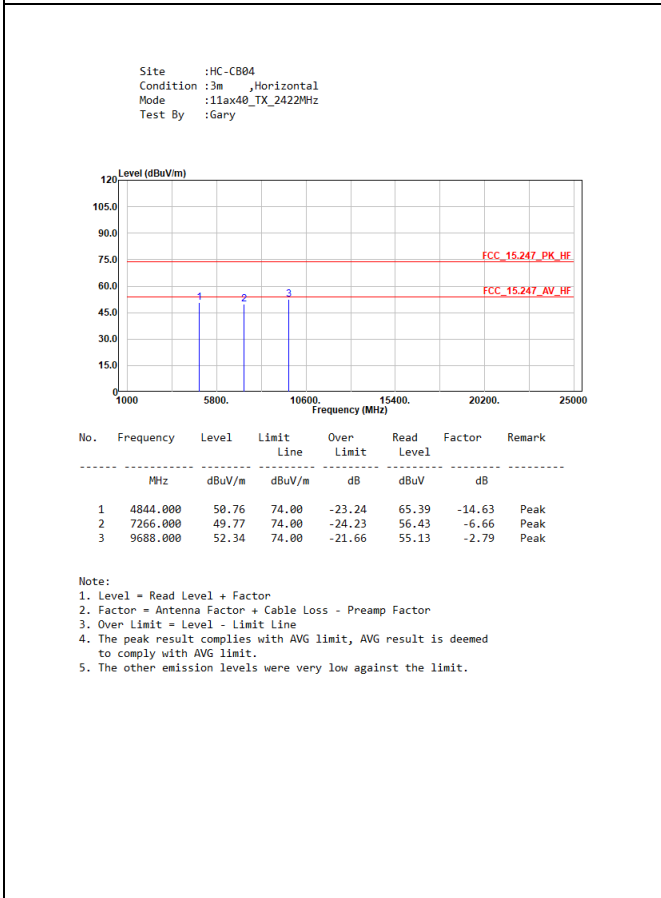
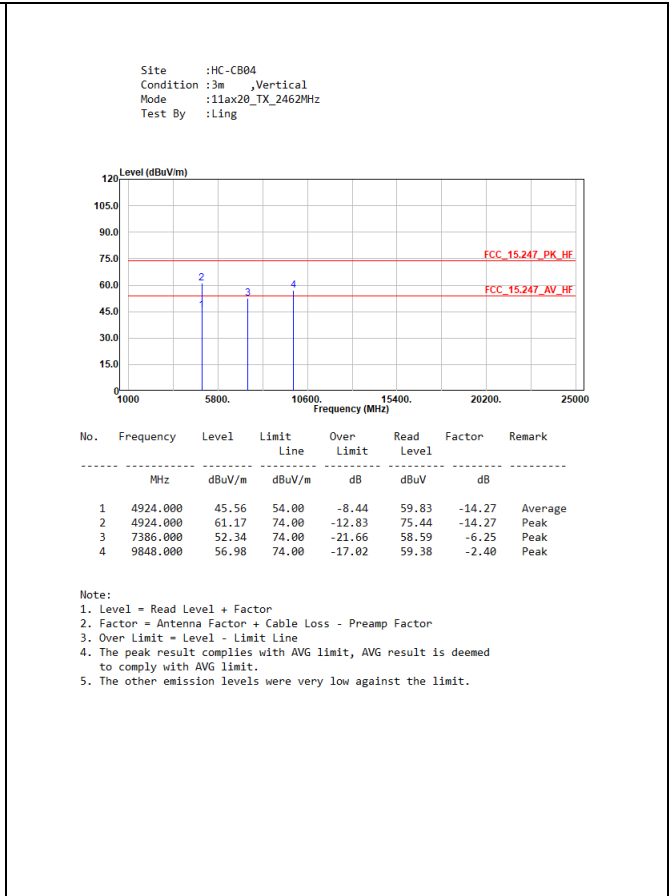
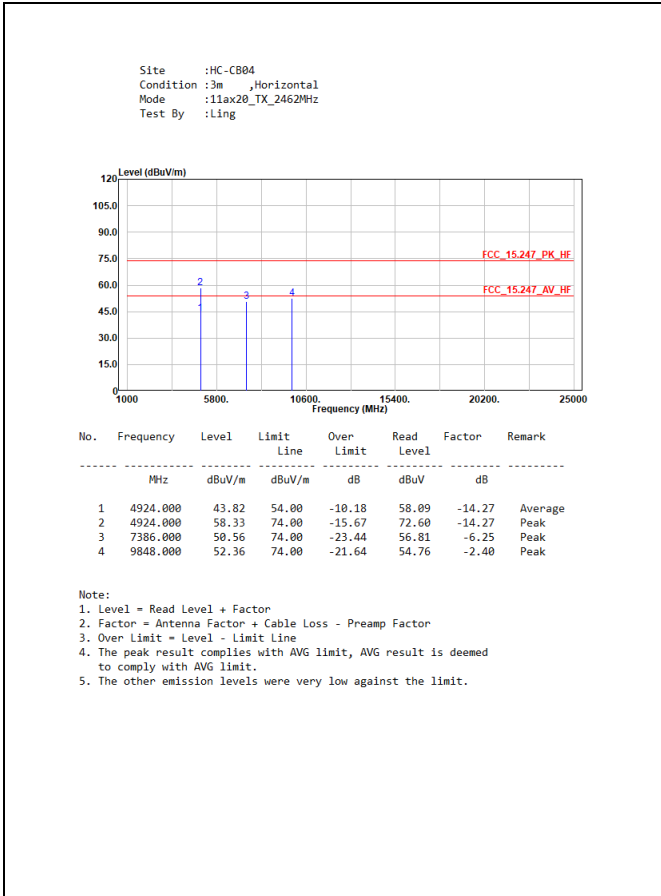

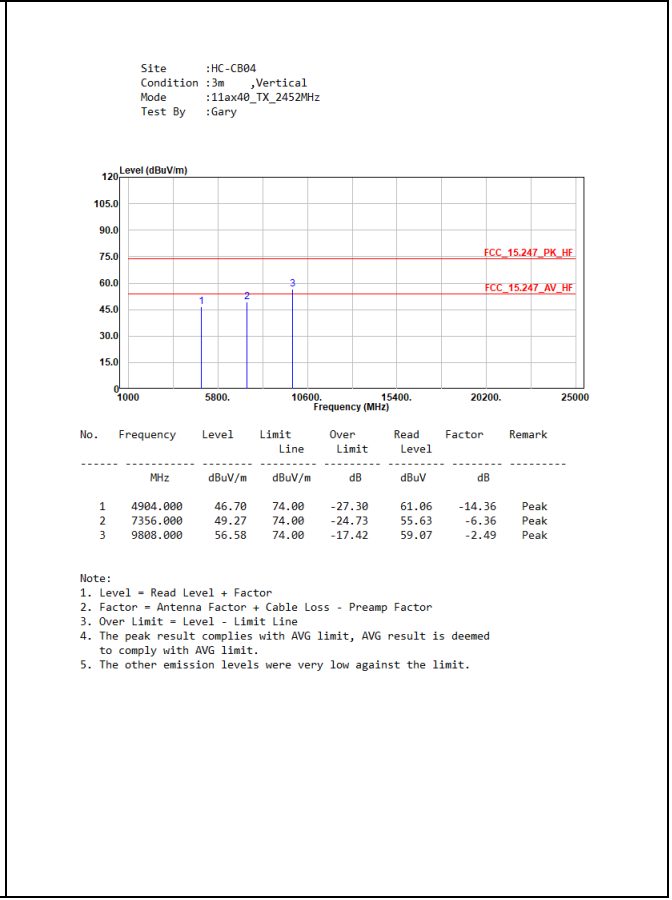
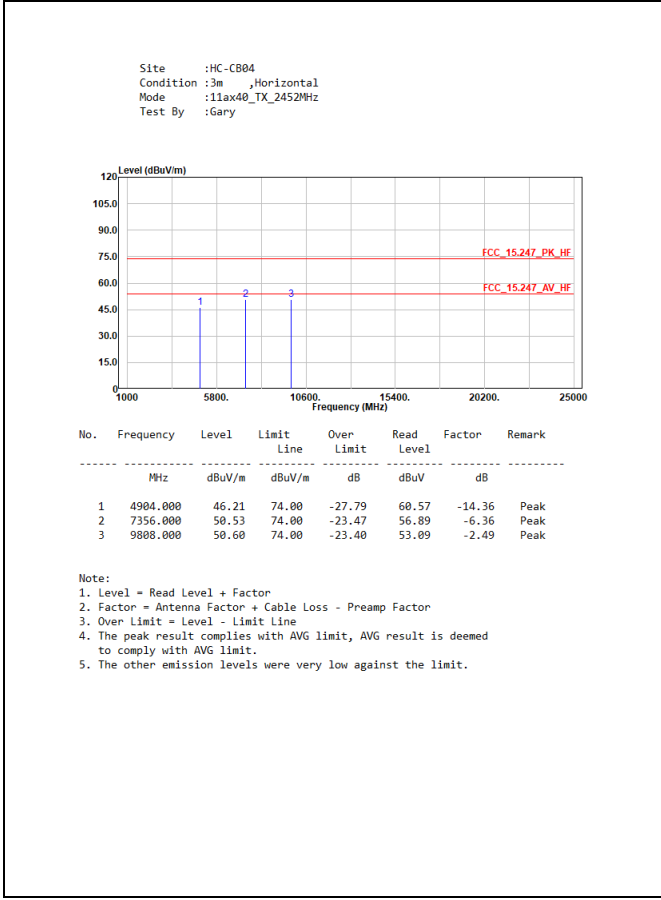
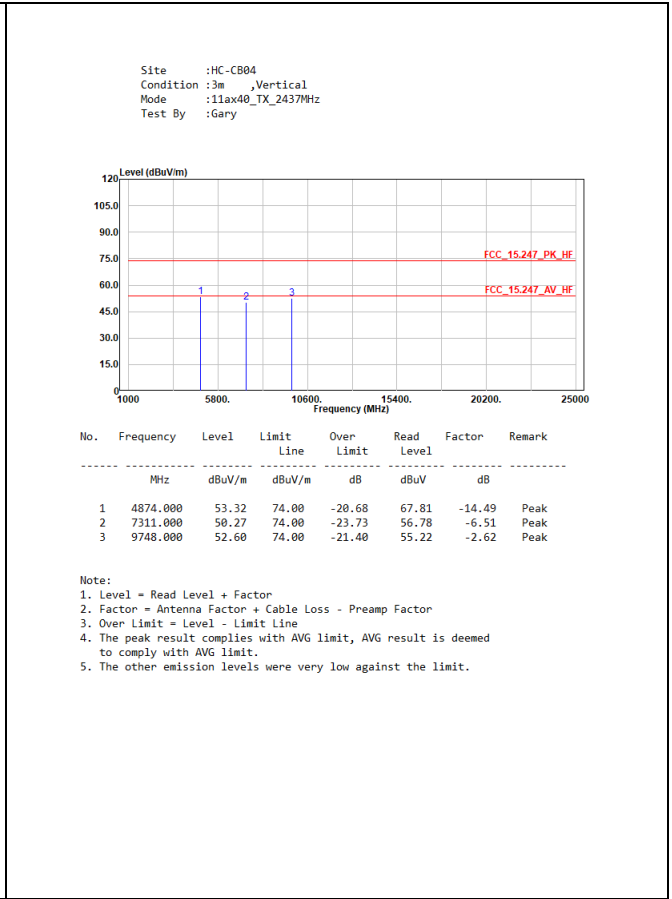
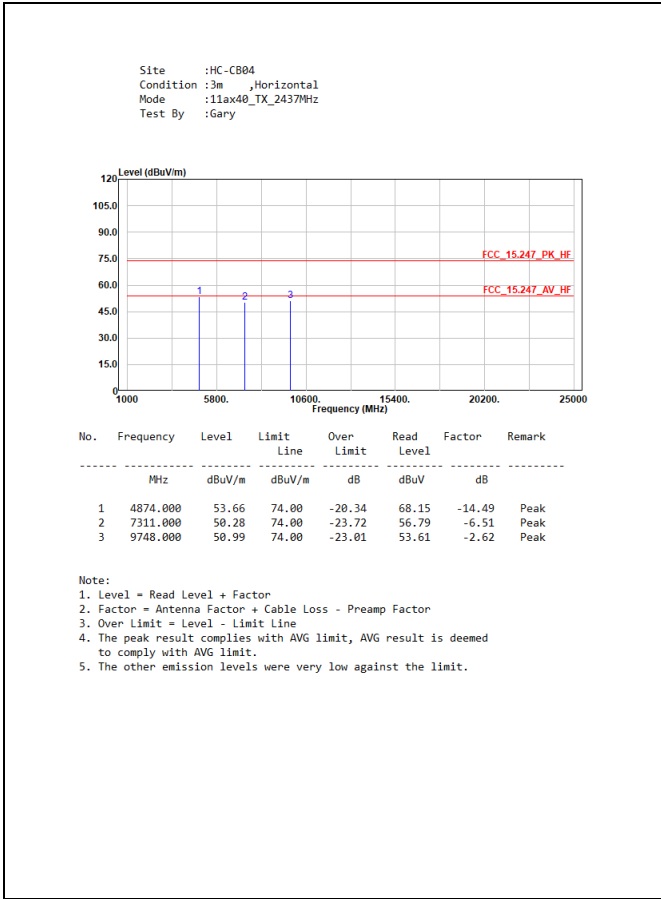

5. Antenna Port Conducted Emission

5.1. Test Setup

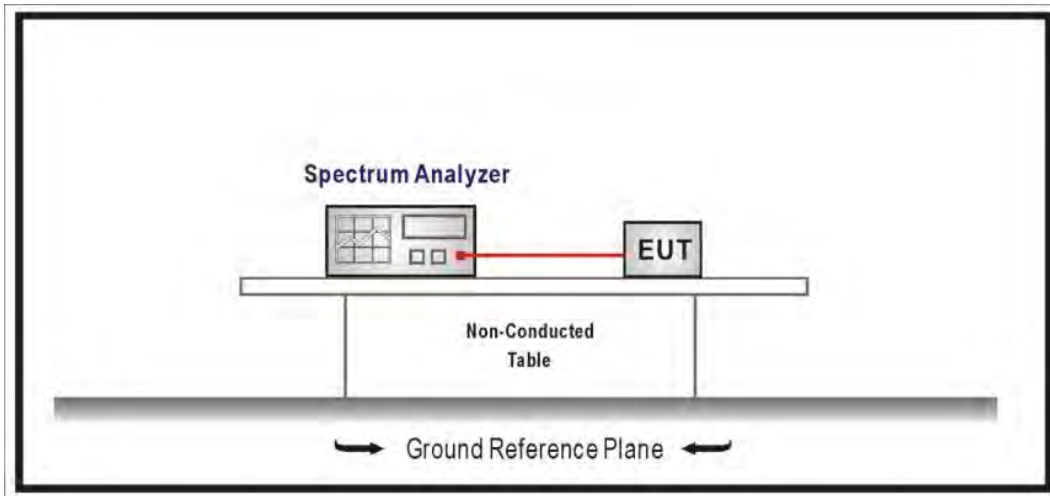

5.2. Test Limit

In any 100 kHz bandwidth outside the frequency band in which the spread spectrum or digitally modulated intentional radiator is operating, the radio frequency power that is produced by the intentional radiator shall be at least 20 dB below that in the 100 kHz bandwidth within the band that contains the highest level of the desired power, based on either an RF conducted or a radiated measurement, provided the transmitter demonstrates compliance with the peak conducted power limit. If the transmitter complies with the conducted power limit based on the use of RMS averaging over a time interval, the attenuation required under this paragraph shall be 30 dB instead of 20 dB. Attenuation below the general limit specified in §15.209(a) is not required. In addition, radiated emissions which fall in the restricted bands, as defined in §15.205(a), must also comply with the radiated emission limit specified in §15.209(a) (see §15.205(c)).

5.3. Test Procedure

The EUT was setup according to ANSI C63.10: 2013 and tested according to DTS test procedure of KDB 558074 D01 V05r02 for compliance to FCC 47CFR 15.247 requirements.

Set RBW = 100 kHz, Set VBW > RBW, scan up through 10th harmonic.

5.4. Test Specification

According to FCC Part 15 Subpart C Paragraph 15.247.

5.5. Test Result of Antenna Port Conducted Emission

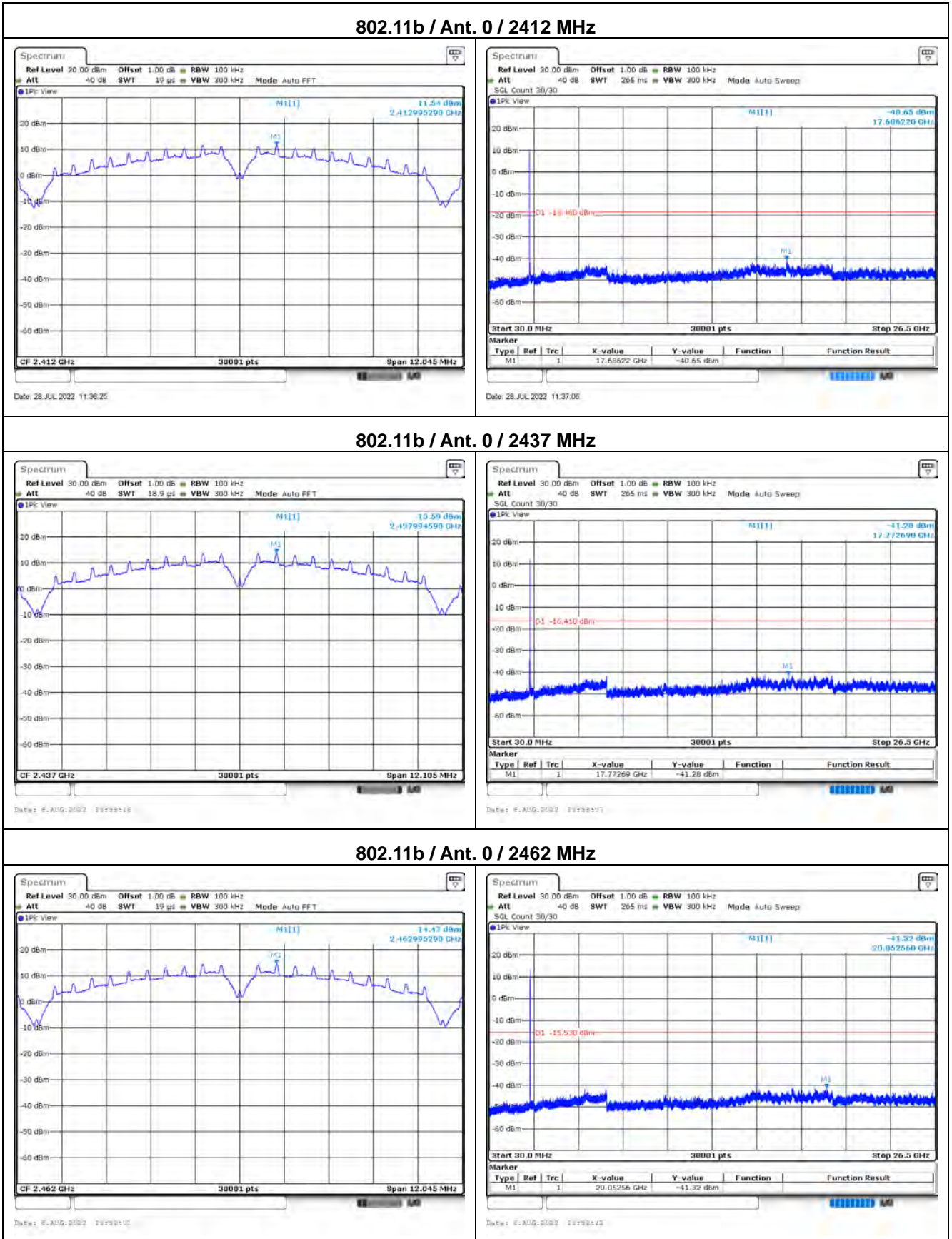

802.11g / Ant. 0 / 2412 MHz

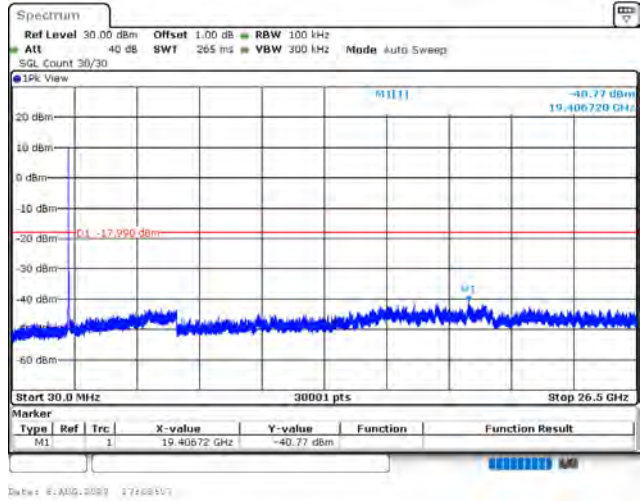
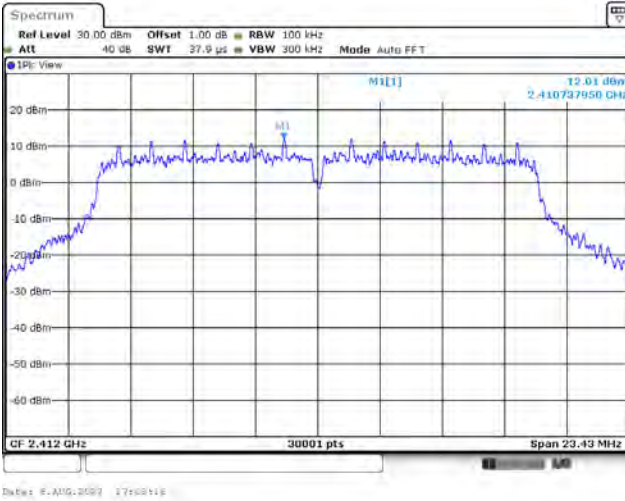

802.11g / Ant. 0 / 2437 MHz

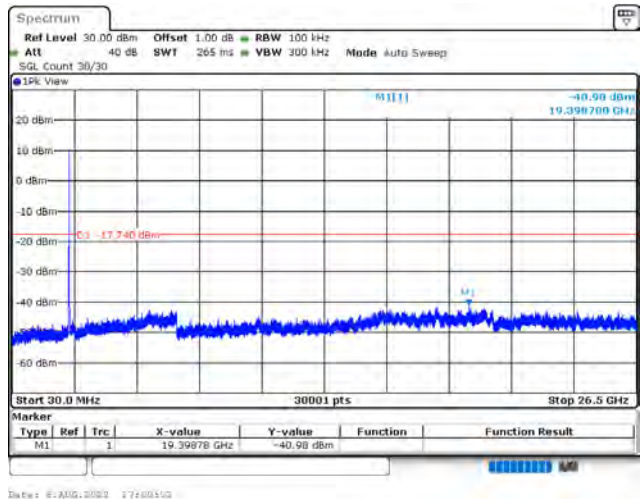
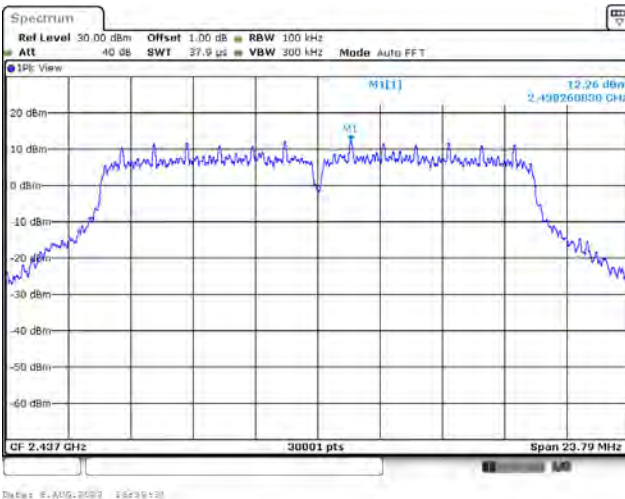

802.11g / Ant. 0 / 2462 MHz

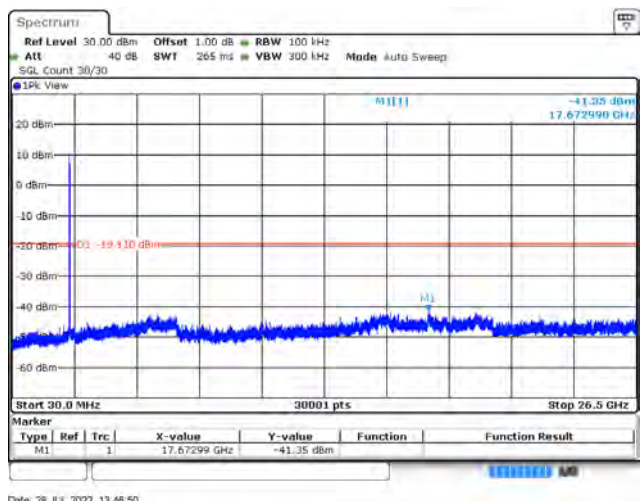
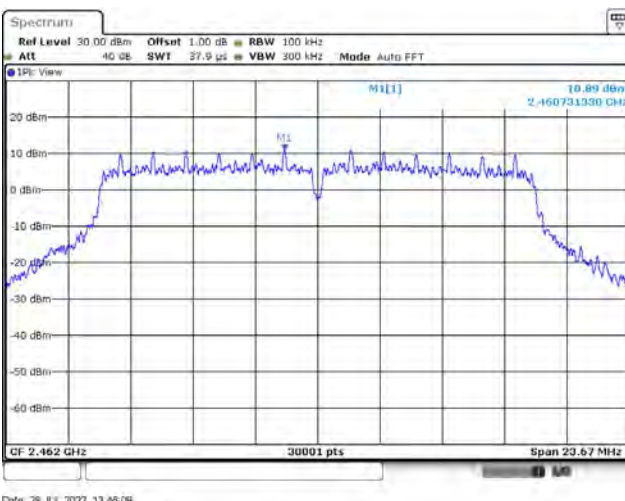

802.11ax (20 MHz) / Ant. 0 / 2412 MHz

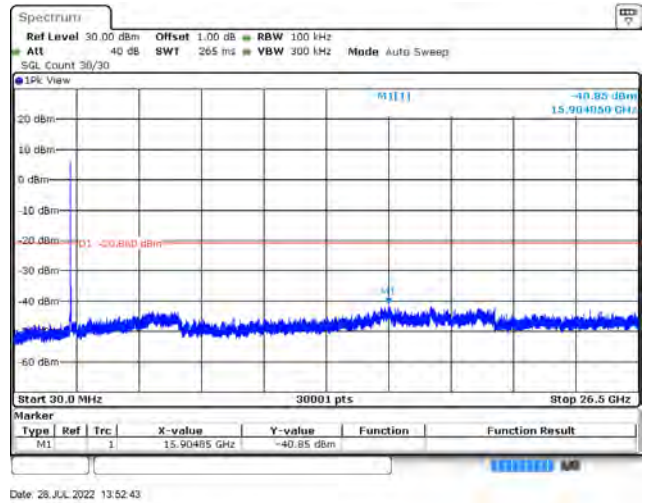
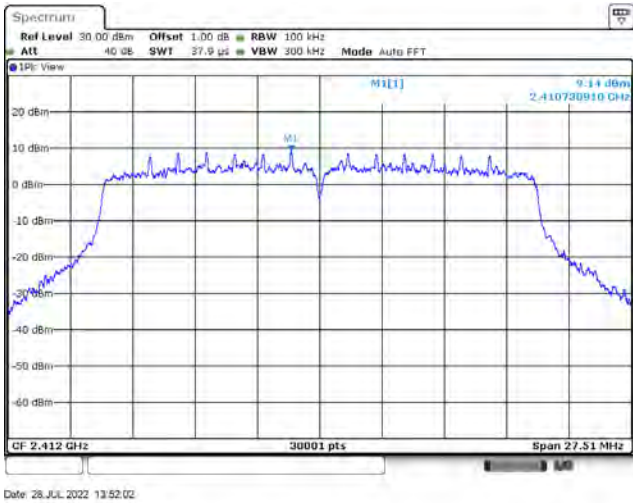

802.11ax (20 MHz) / Ant. 0 / 2437 MHz

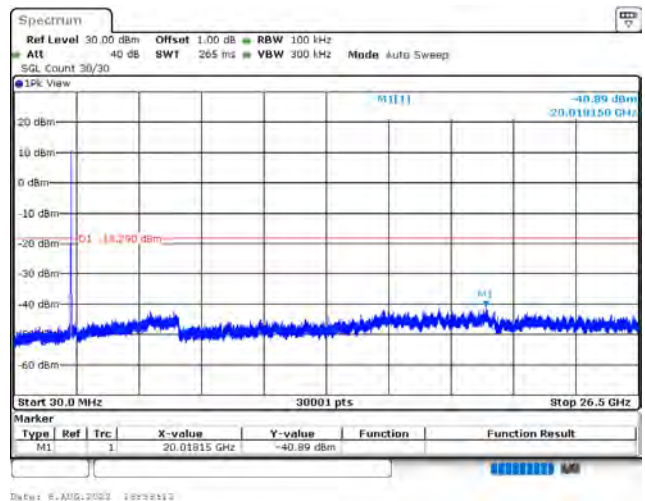
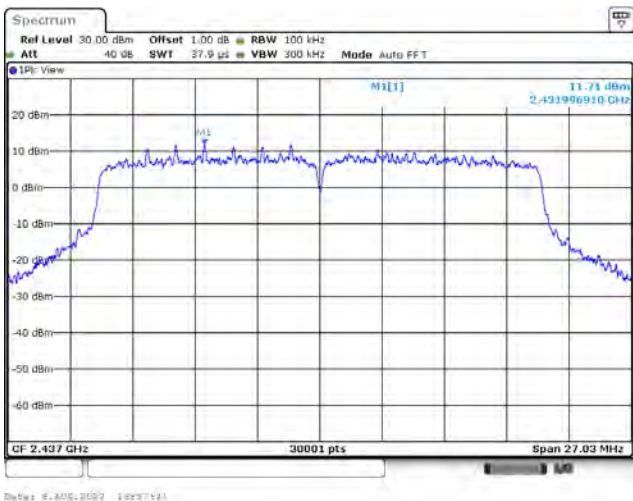

802.11ax (20 MHz) / Ant. 0 / 2462 MHz

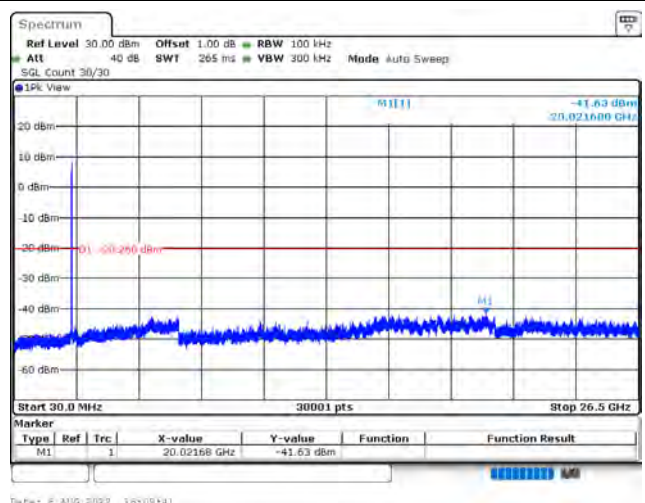
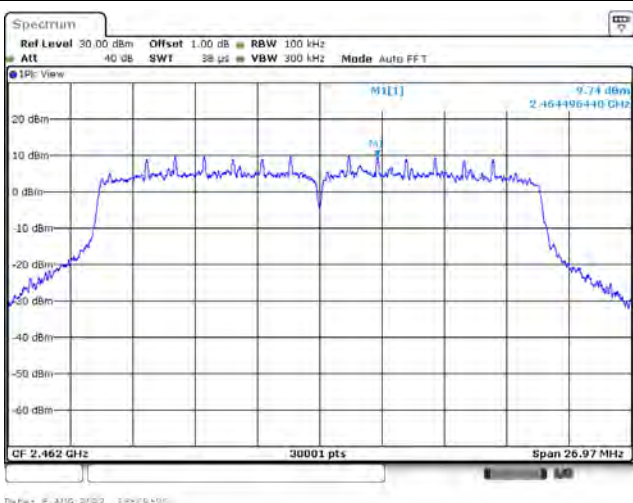

802.11ax (40 MHz) / Ant. 0 / 2422 MHz

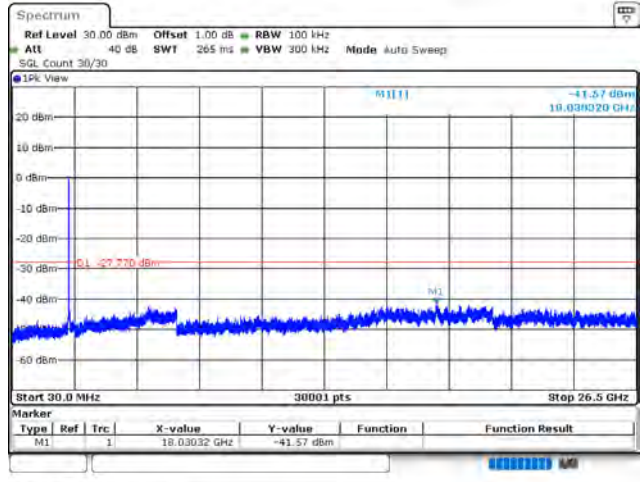
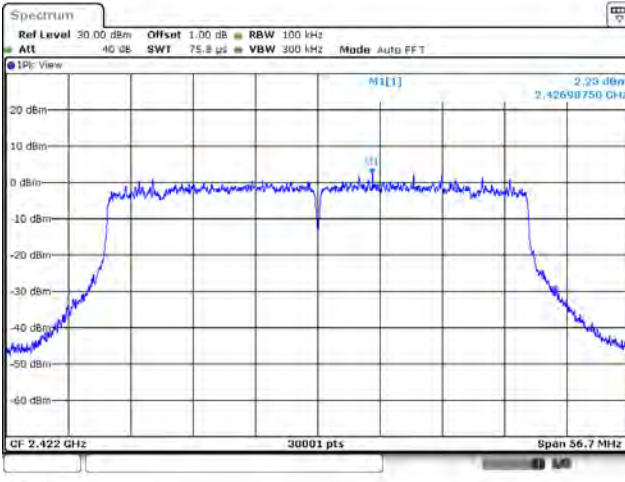

802.11ax (40 MHz) / Ant. 0 / 2437 MHz

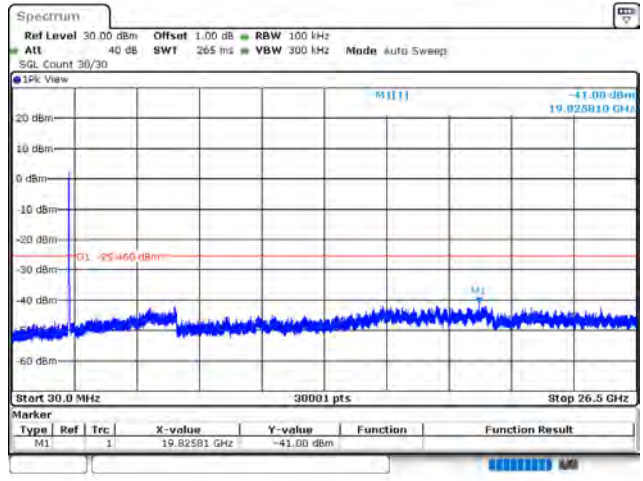
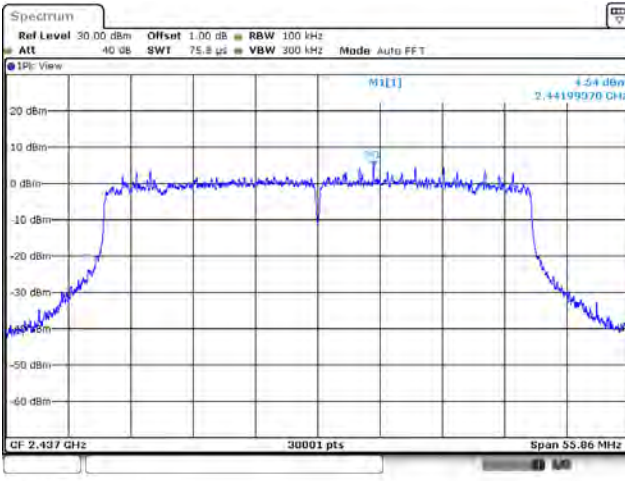

802.11ax (40 MHz) / Ant. 0 / 2452 MHz

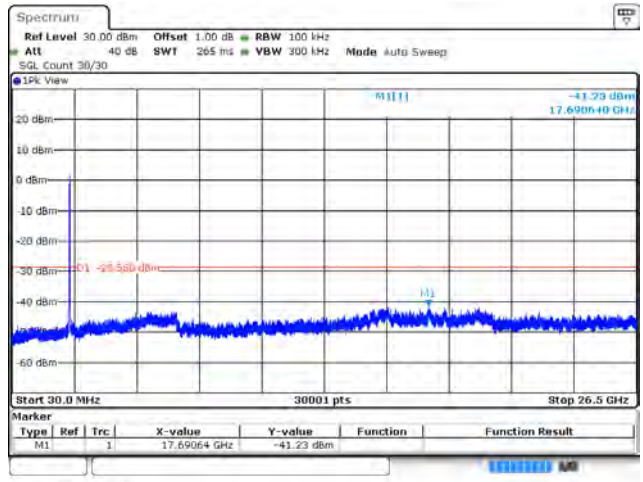
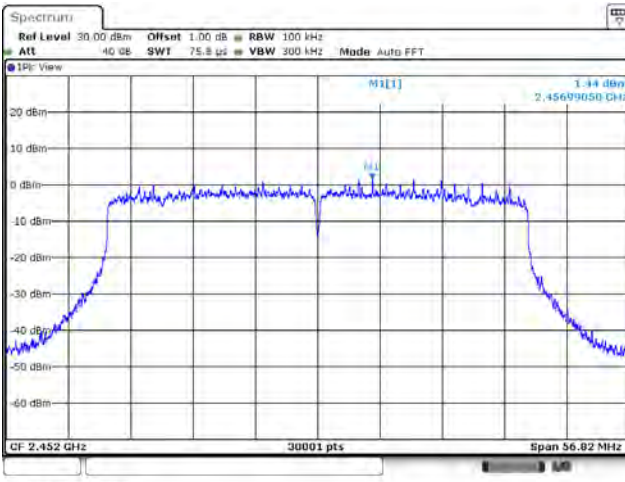

802.11b / Ant. 1 / 2412 MHz

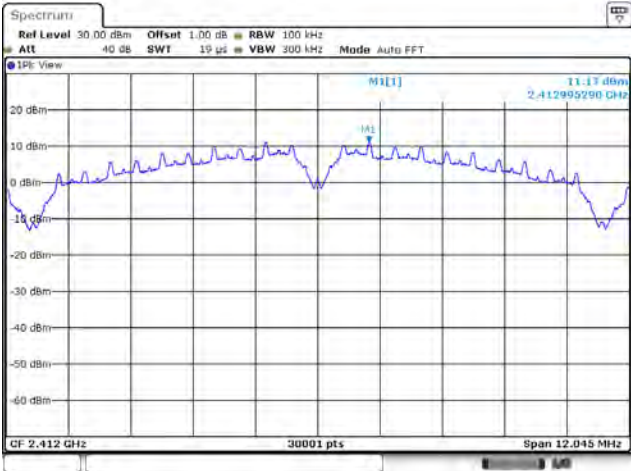

Date: 28.JUL.2022 11:43:25

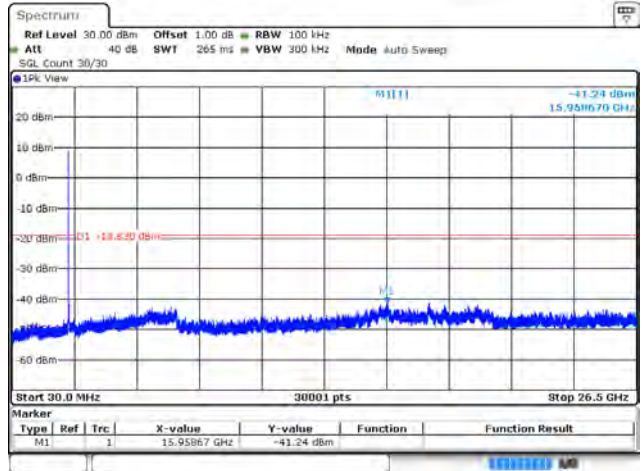

Date: 28.JUL.2022 11:44:05

802.11b / Ant. 1 / 2437 MHz

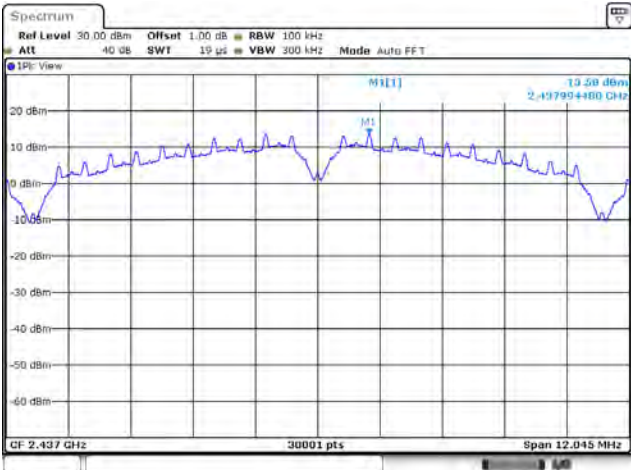

Date: 8.AUG.2022 15:08:15

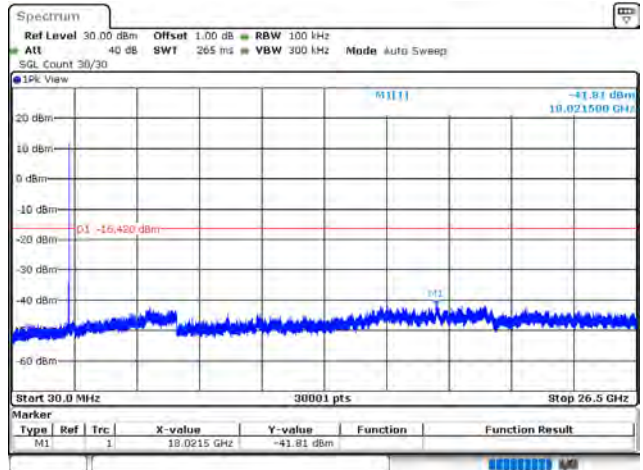

Date: 8.AUG.2022 15:09:10

802.11b / Ant. 1 / 2462 MHz

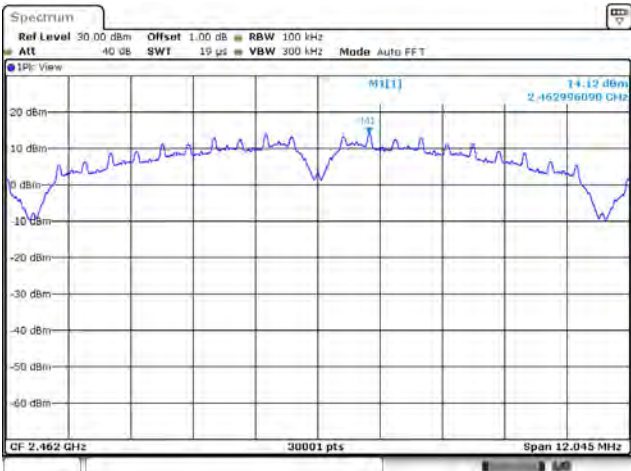

Date: 8.AUG.2022 15:10:15

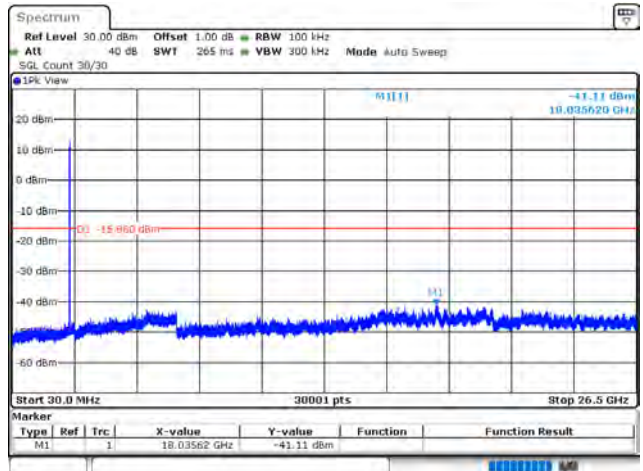

Date: 8.AUG.2022 15:10:17

802.11g / Ant. 1 / 2412 MHz

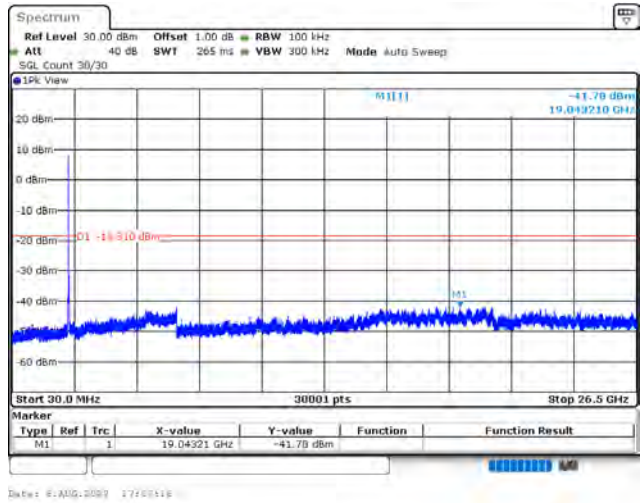
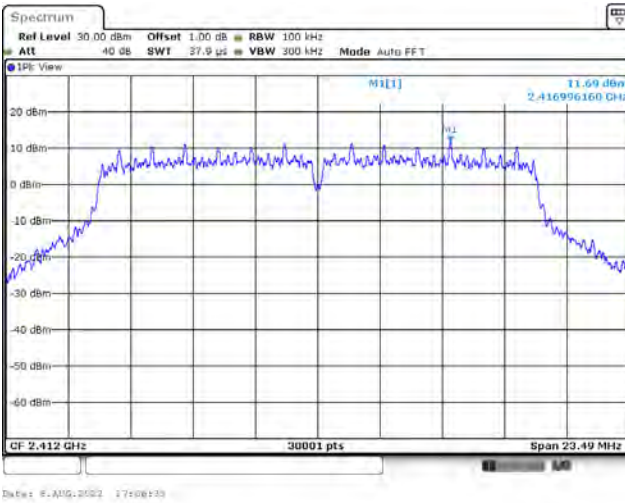

802.11g / Ant. 1 / 2437 MHz

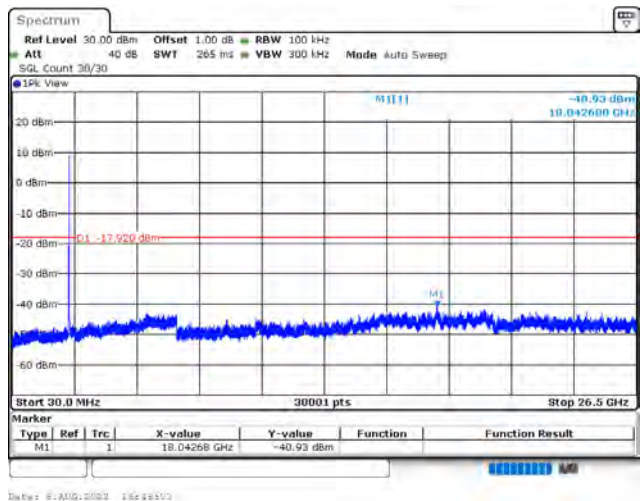
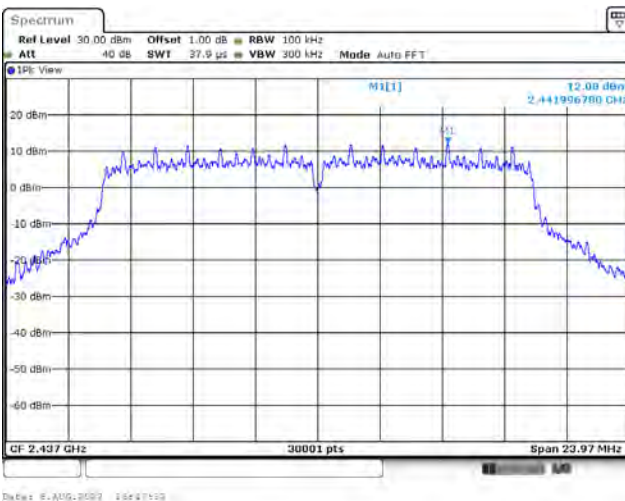

802.11g / Ant. 1 / 2462 MHz

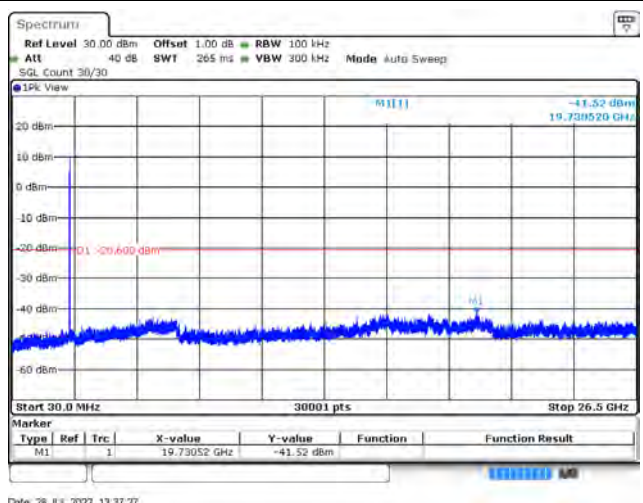
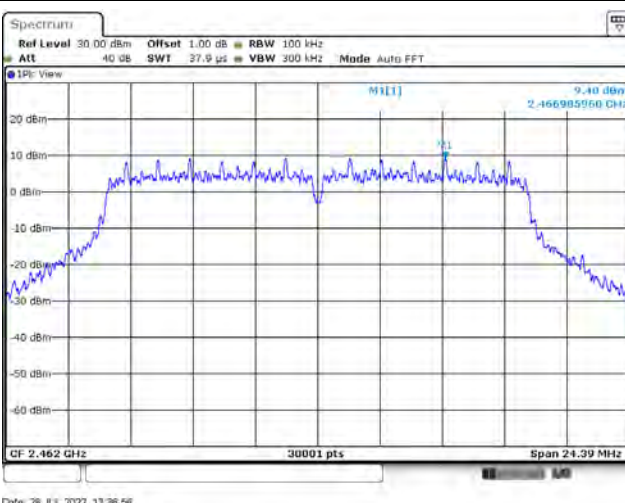

802.11ax (20 MHz) / Ant. 1 / 2412 MHz

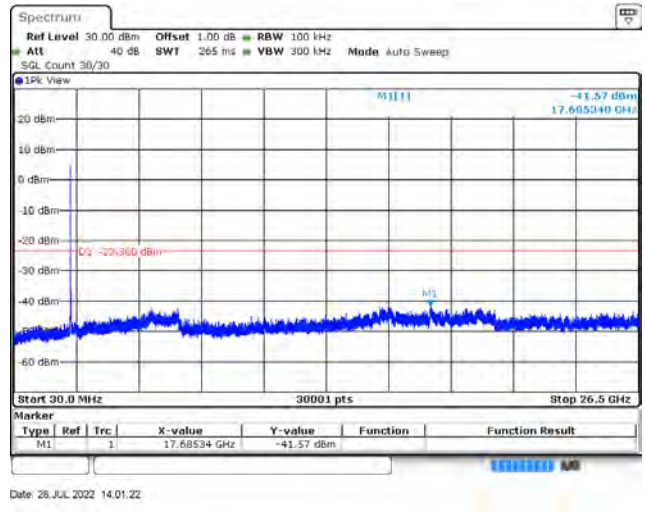
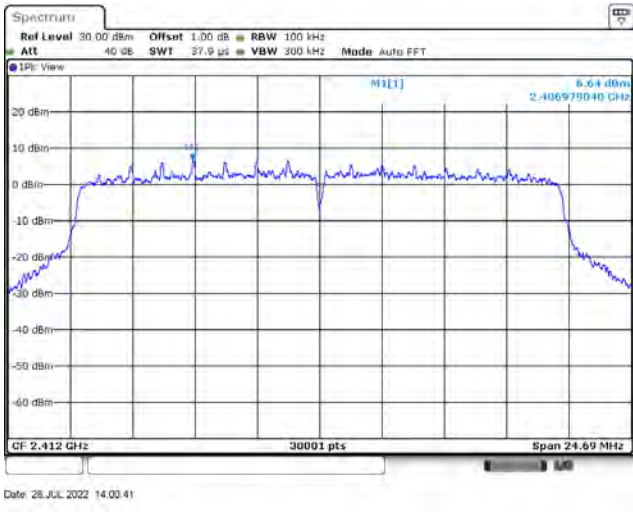

802.11ax (20 MHz) / Ant. 1 / 2437 MHz

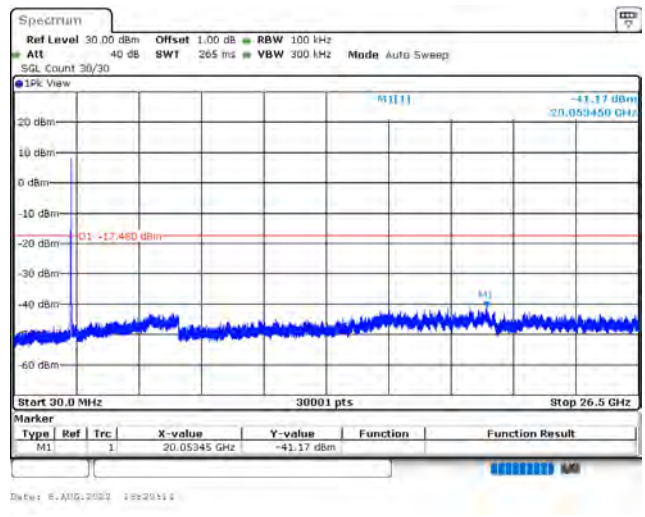
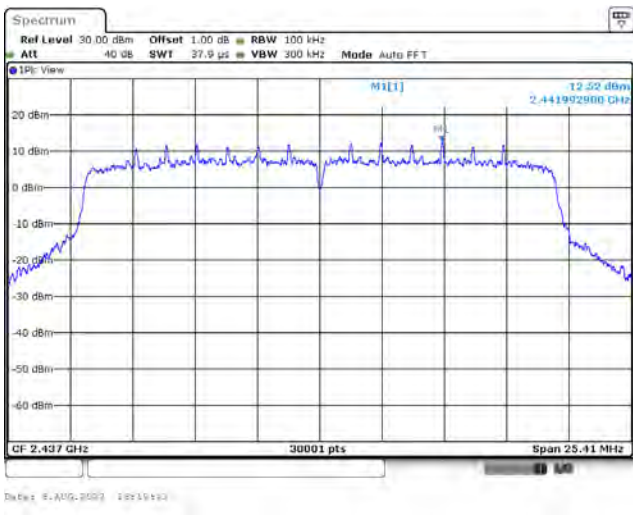

802.11ax (20 MHz) / Ant. 1 / 2462 MHz

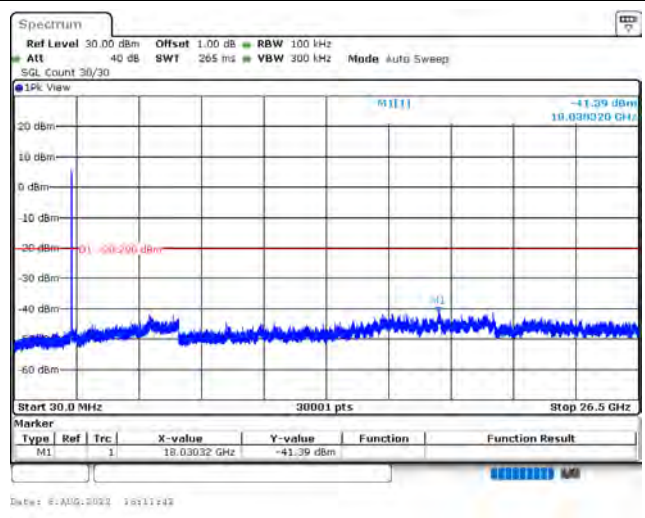
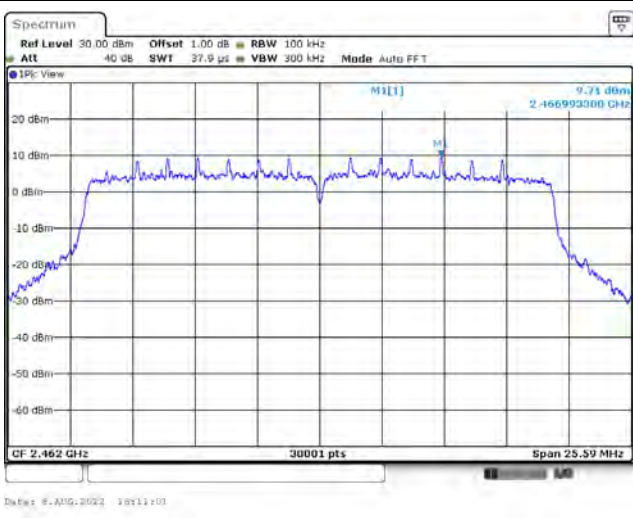

802.11ax (40 MHz) / Ant. 1 / 2422 MHz

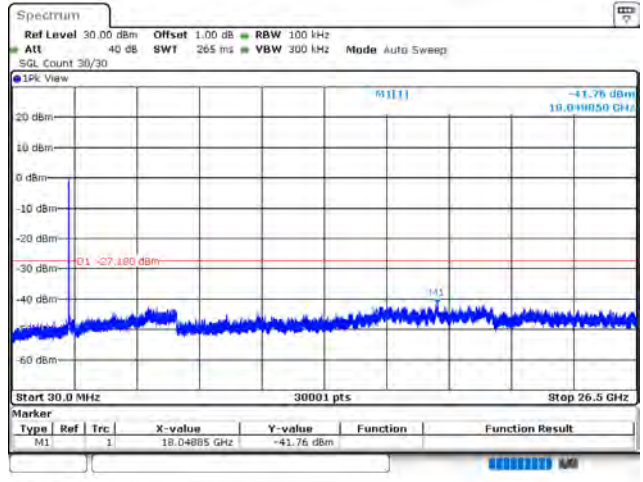
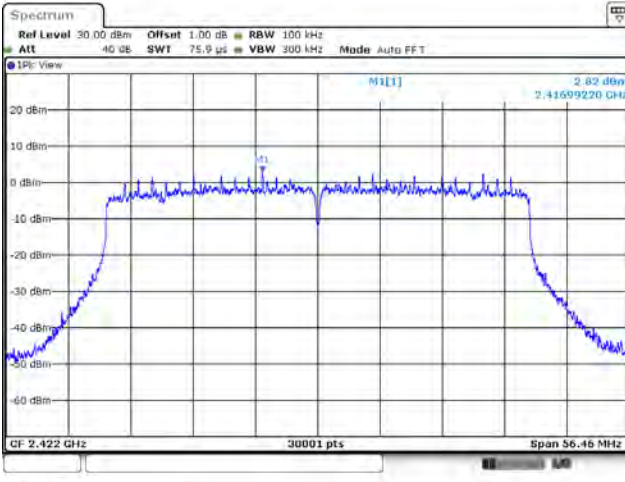

802.11ax (40 MHz) / Ant. 1 / 2437 MHz

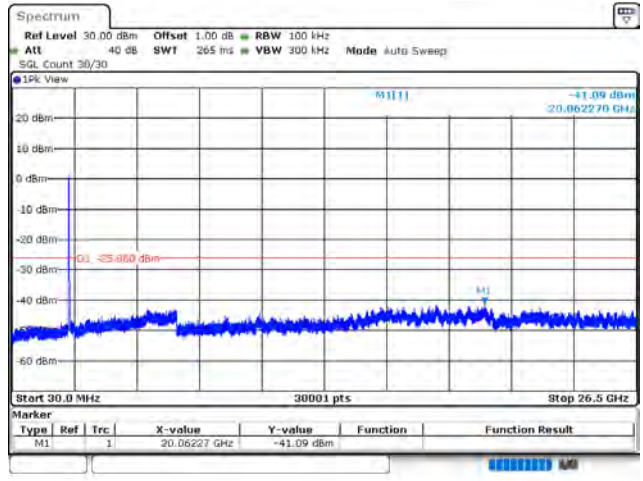
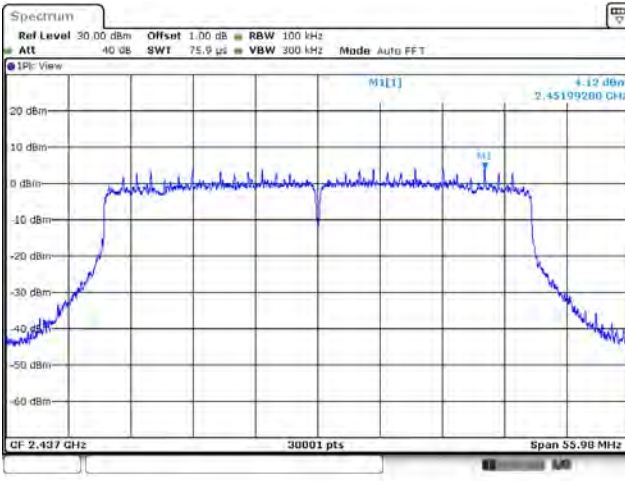

802.11ax (40 MHz) / Ant. 1 / 2452 MHz

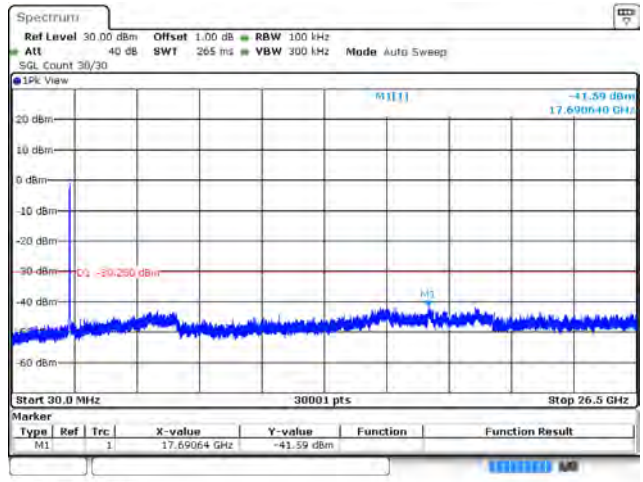
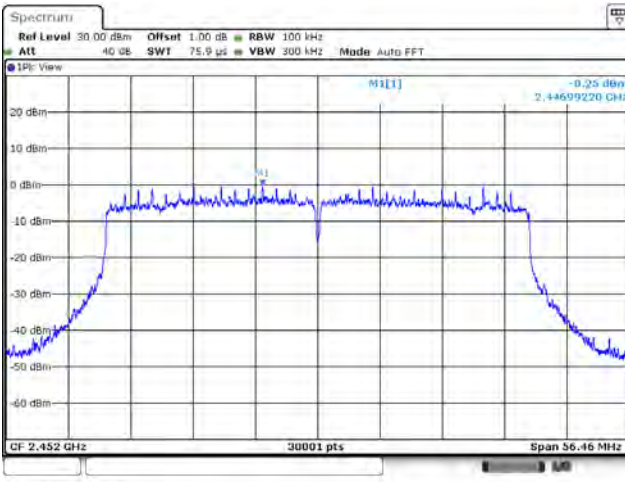

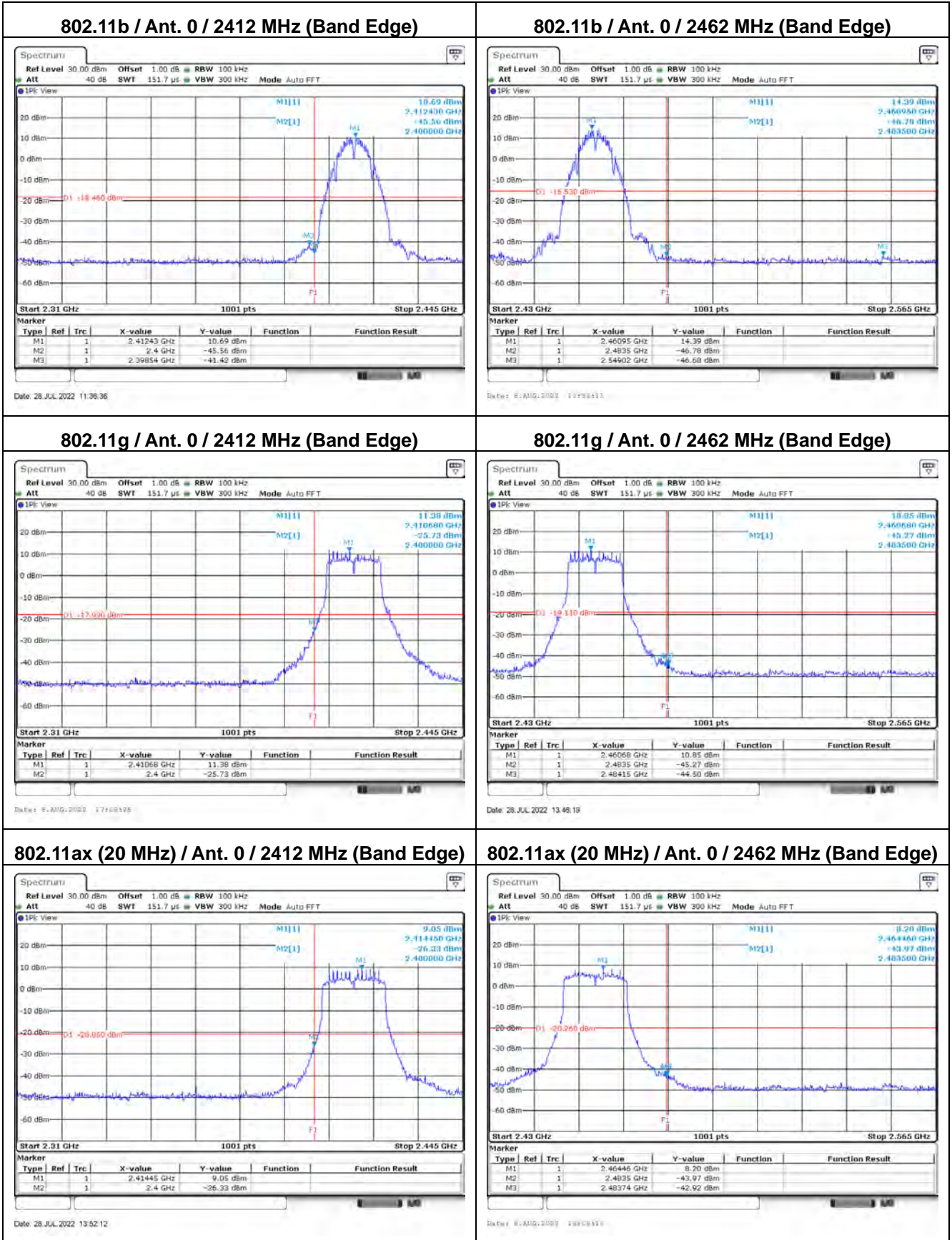

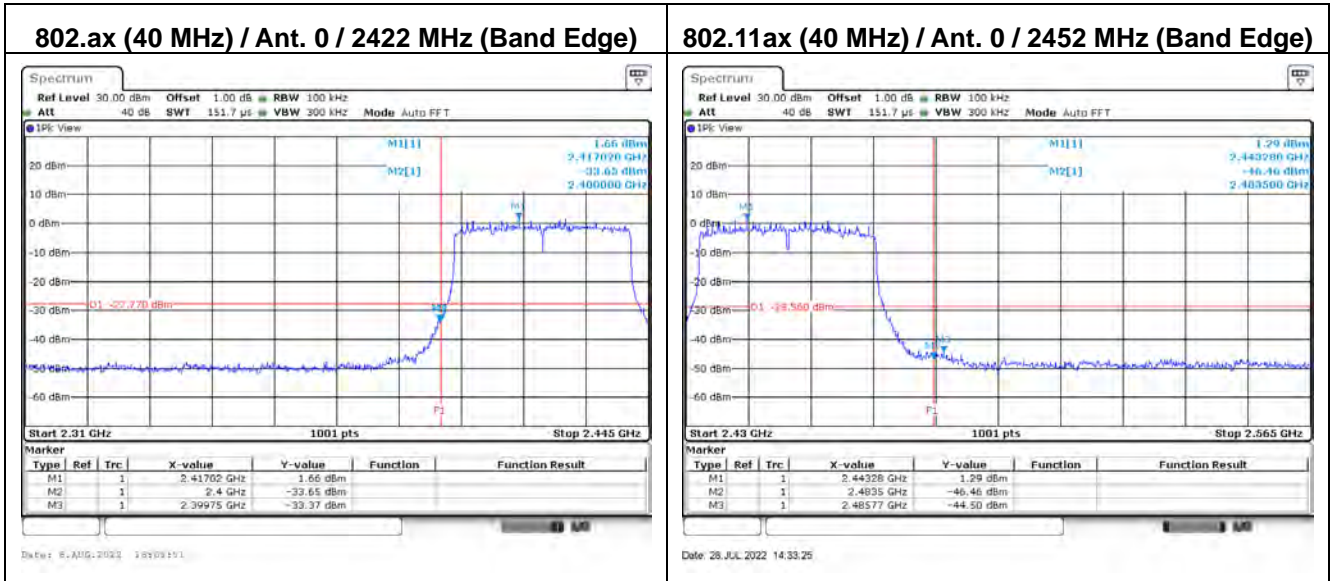

802.11b / Ant. 1 / 2412 MHz (Band Edge)

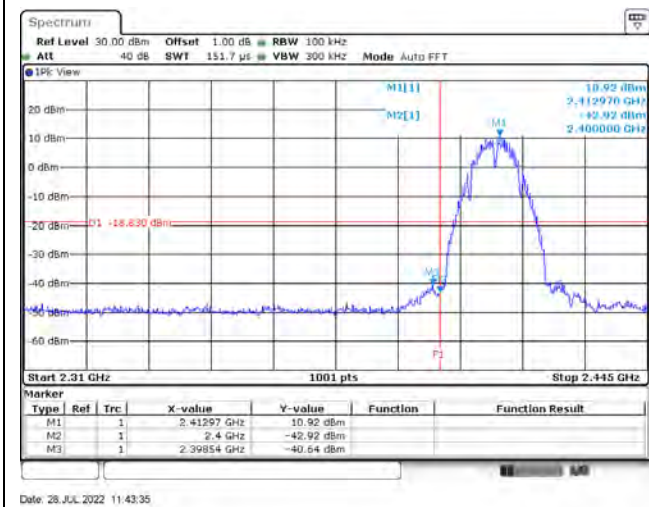

802.11b / Ant. 1 / 2462 MHz (Band Edge)

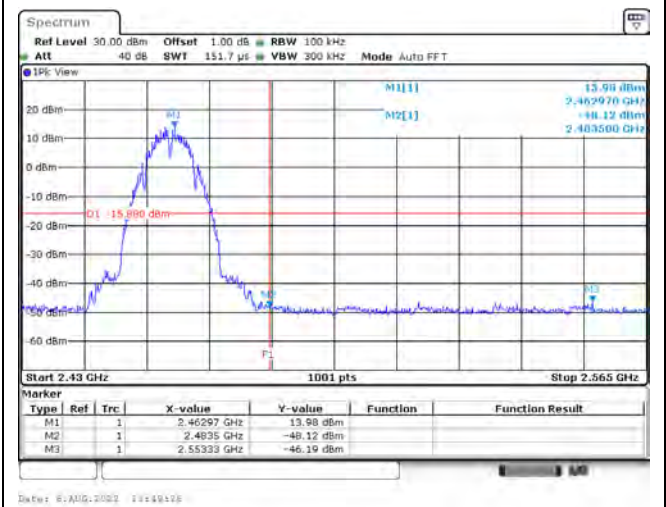

802.11g / Ant. 1 / 2412 MHz (Band Edge)

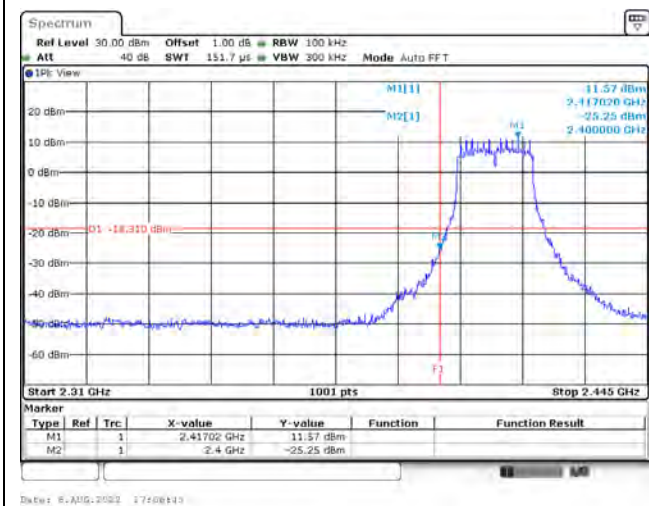

802.11g / Ant. 1 / 2462 MHz (Band Edge)

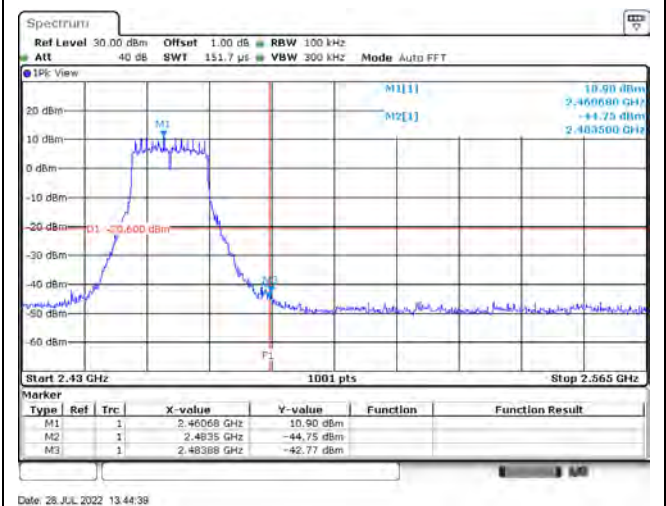

802.11ax (20 MHz) / Ant. 1 / 2412 MHz (Band Edge)

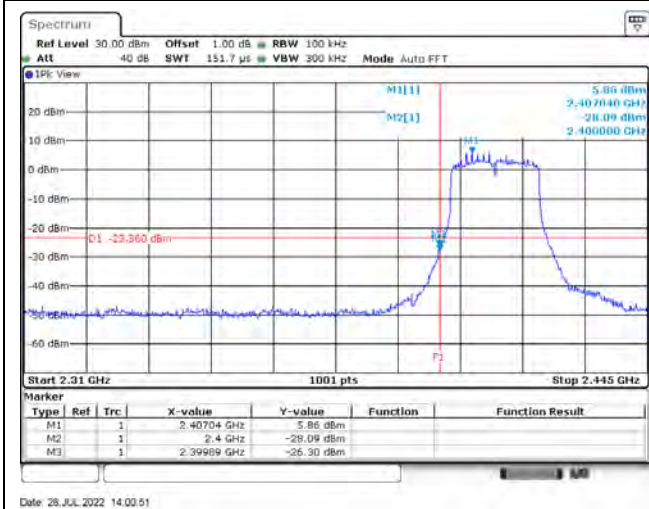

802.11ax (20 MHz) / Ant. 1 / 2462 MHz (Band Edge)

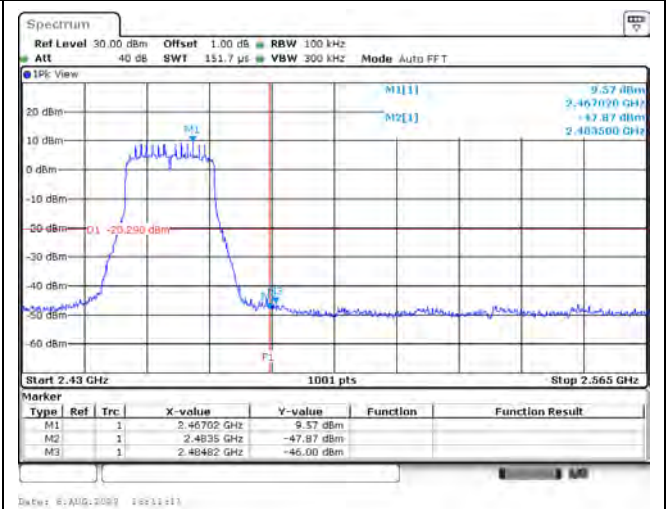

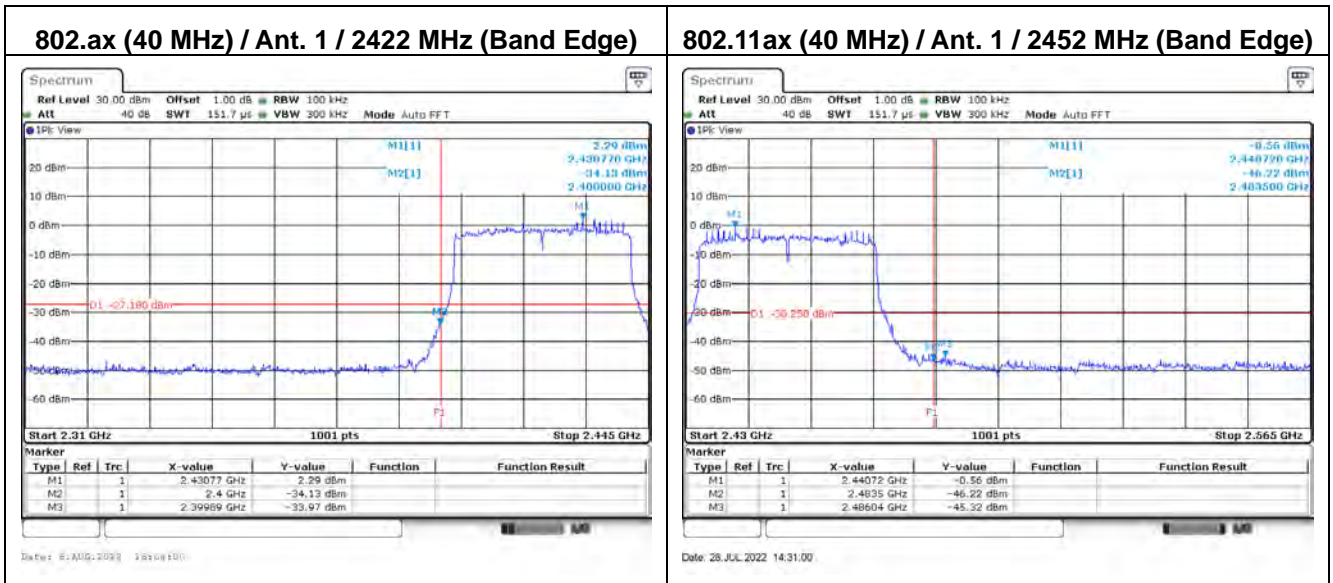

6. Radiated Emission Band Edge

6.1. Test Setup

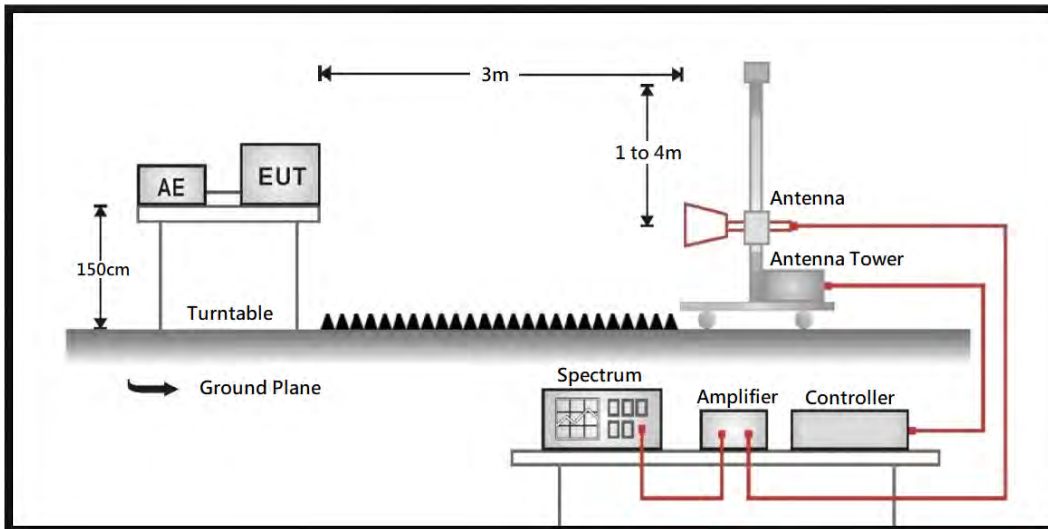

6.2. Test Limit

Emissions radiated outside of the specified frequency bands, except for harmonics, shall be attenuated by at least 30 dB below the level of the fundamental or to the general radiated emission limit in paragraph 15.209, whichever is the lesser attenuation.

Frequency (MHz)	Field strength (uV/m)	Field strength (dBuV/m)	Measurement distance (m)
30 - 88	100	40	3
88 - 216	150	43.5	3
216 - 960	200	46	3
Above 960	500	54	3

Remarks:

1. Field strength (dBuV/m) = 20 log Field strength (uV/m)
2. In the Above Table, the tighter limit applies at the band edges.
3. Distance refers to the distance in meters between the measuring instrument antenna and the closed point of any part of the device or system

6.3. Test Procedure

The EUT was setup according to ANSI C63.10: 2013 and tested according to the FCC KDB 558074 D01 v05r02 for compliance to FCC 47CFR 15.247 requirements.

The EUT and its simulators are placed on a turn table which is 1.5 meter above ground. The turn table can rotate 360 degrees to determine the position of the maximum emission level. The antenna can move up and down between 1 meter and 4 meters to find out the maximum emission level.

Both horizontal and vertical polarization of the antenna are set on measurement. In order to find the maximum emission, all of the interface cables must be manipulated according to ANSI C63.10: 2013 on radiated measurement.

6.4. Test Specification

According to FCC Part 15 Subpart C Paragraph 15.247.

6.5. Test Result of Radiated Emission Band Edge

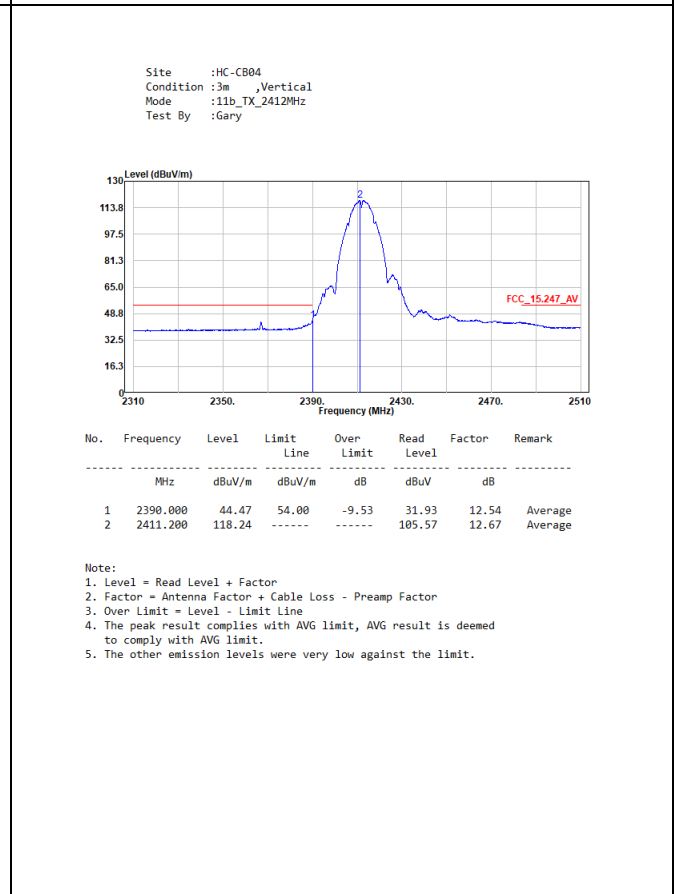
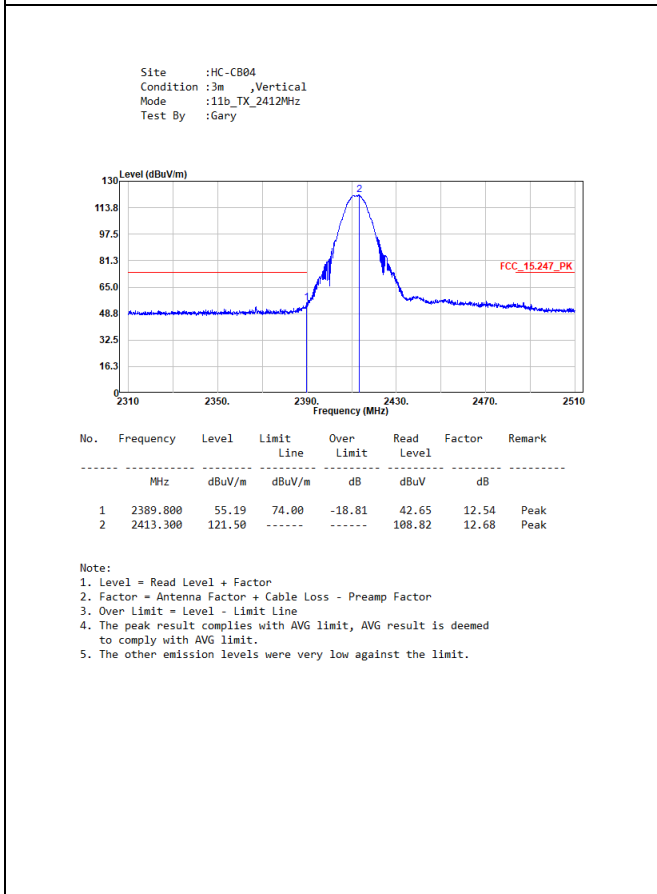
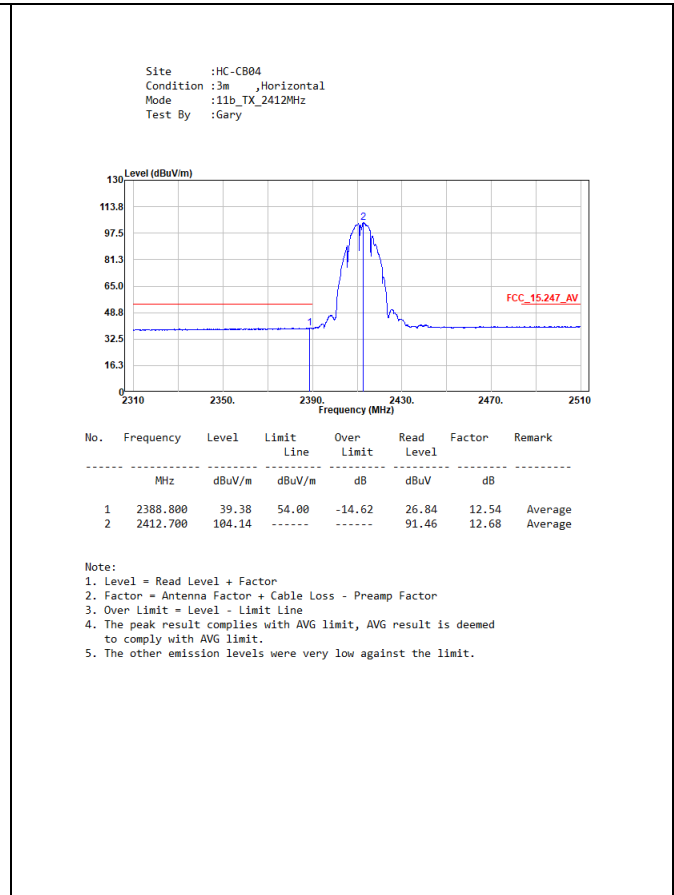
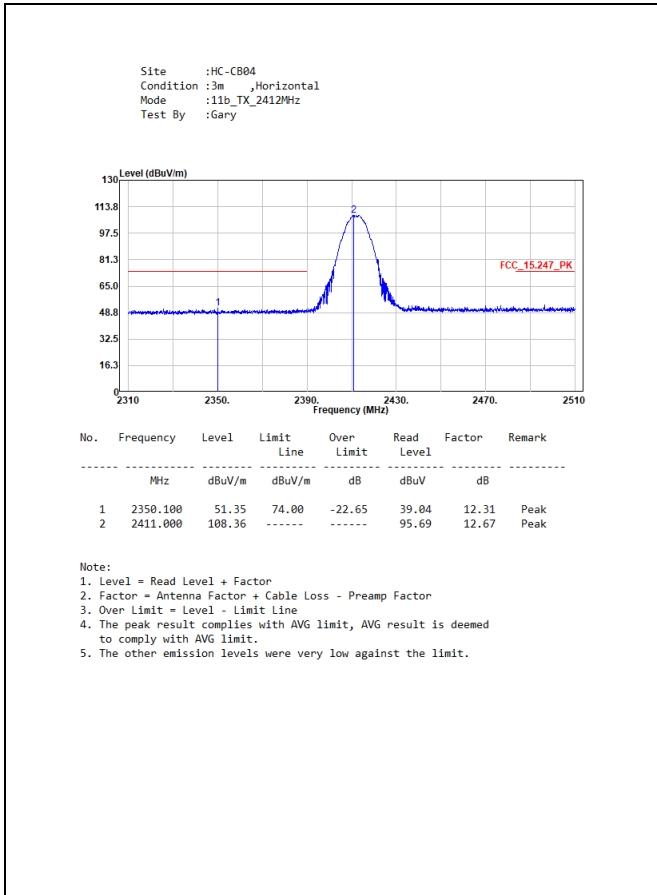

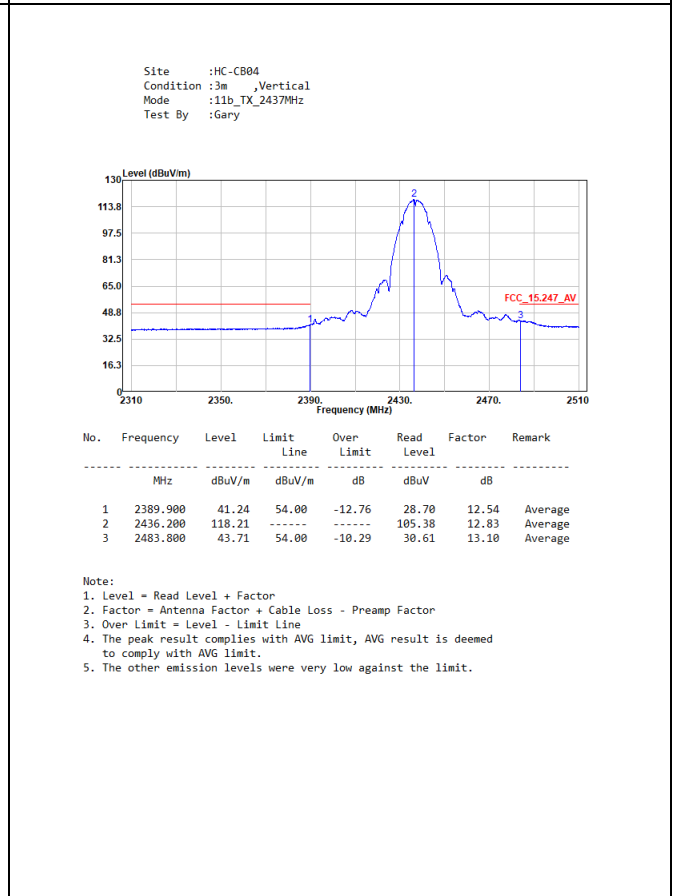
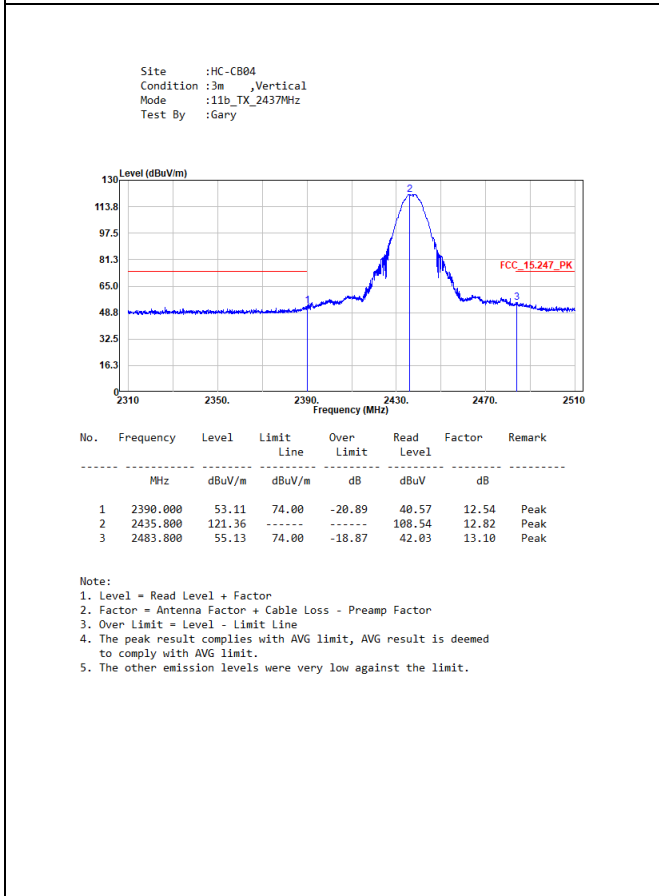
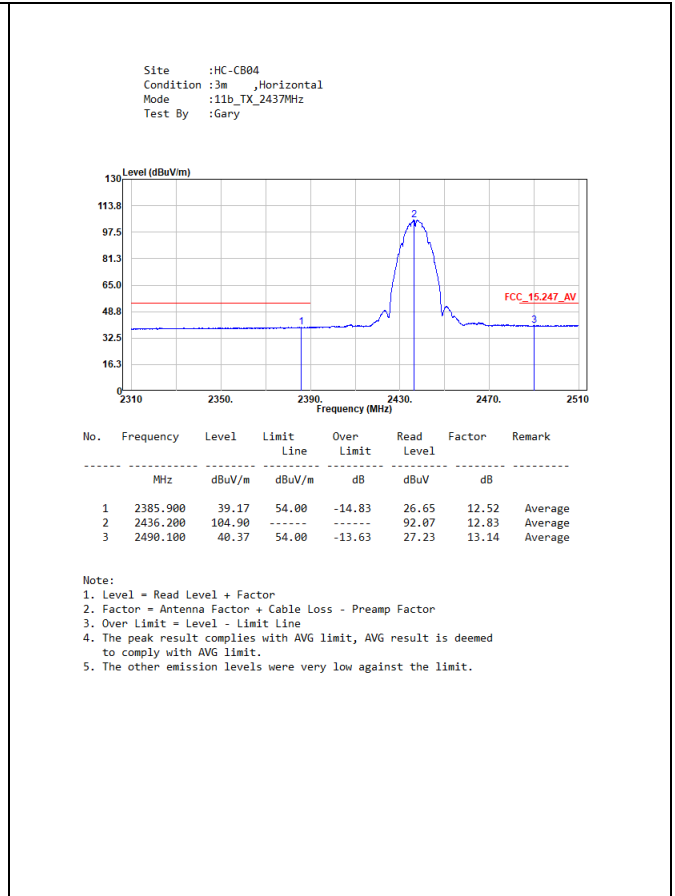
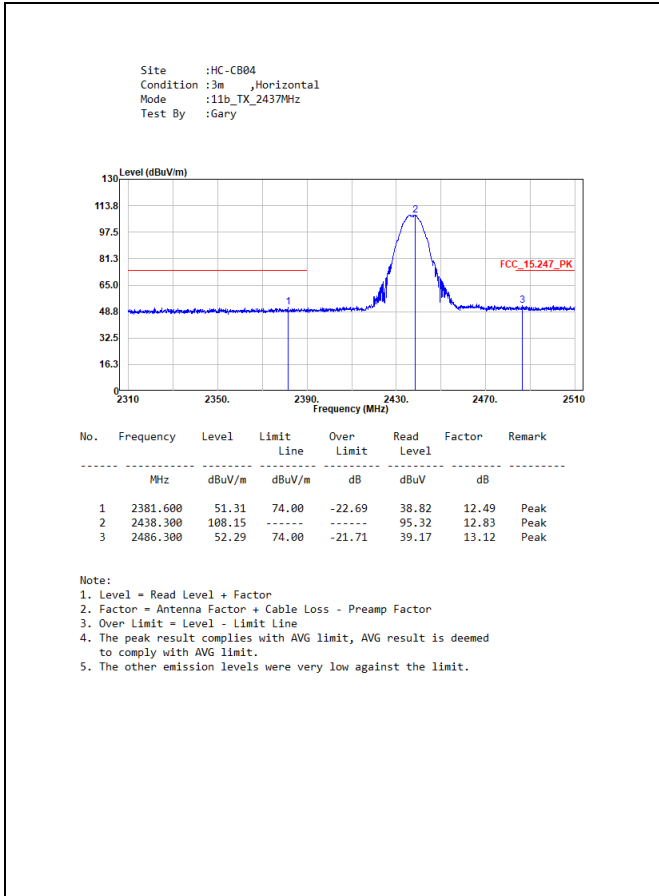

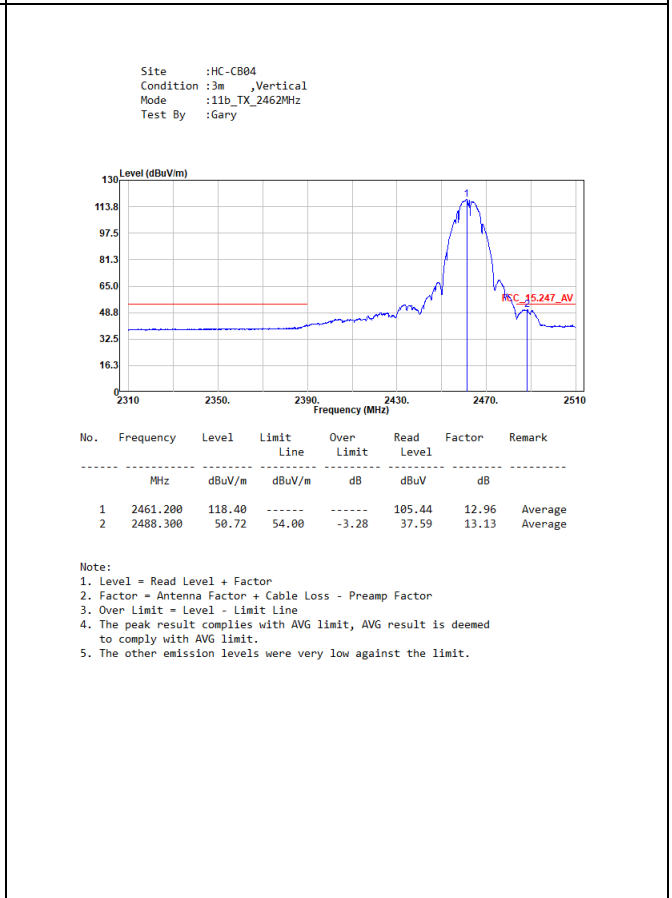
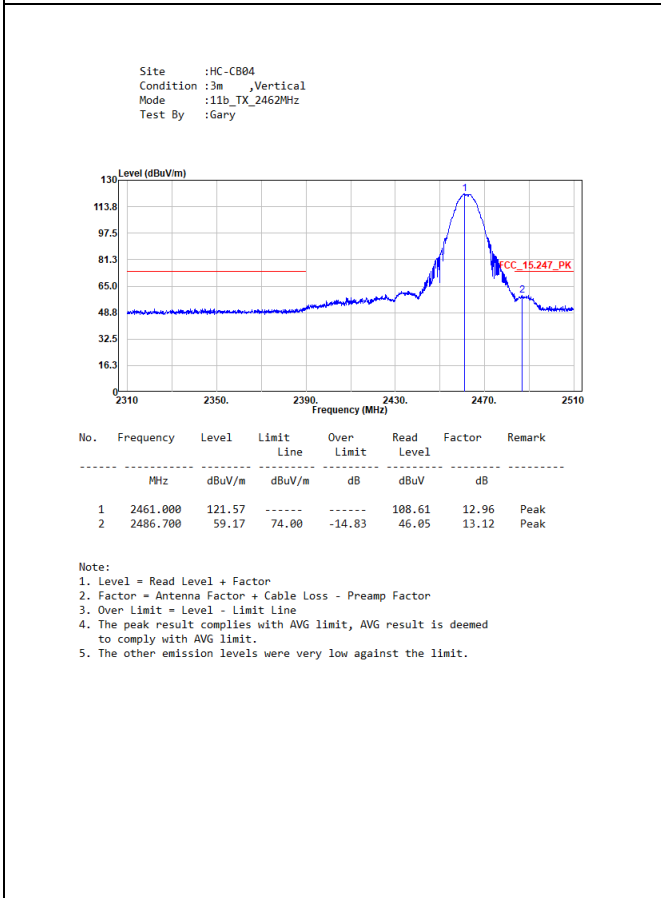
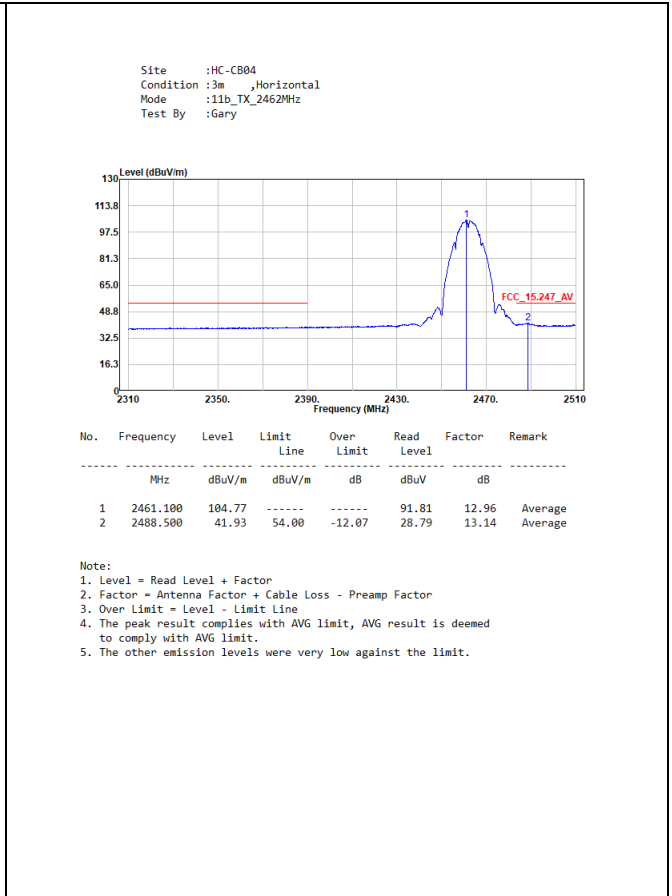
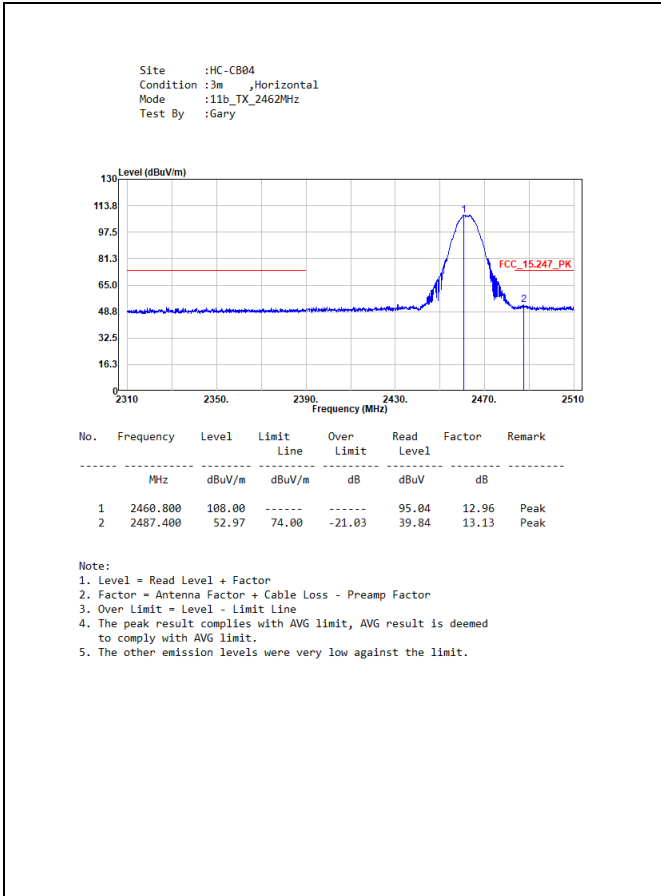

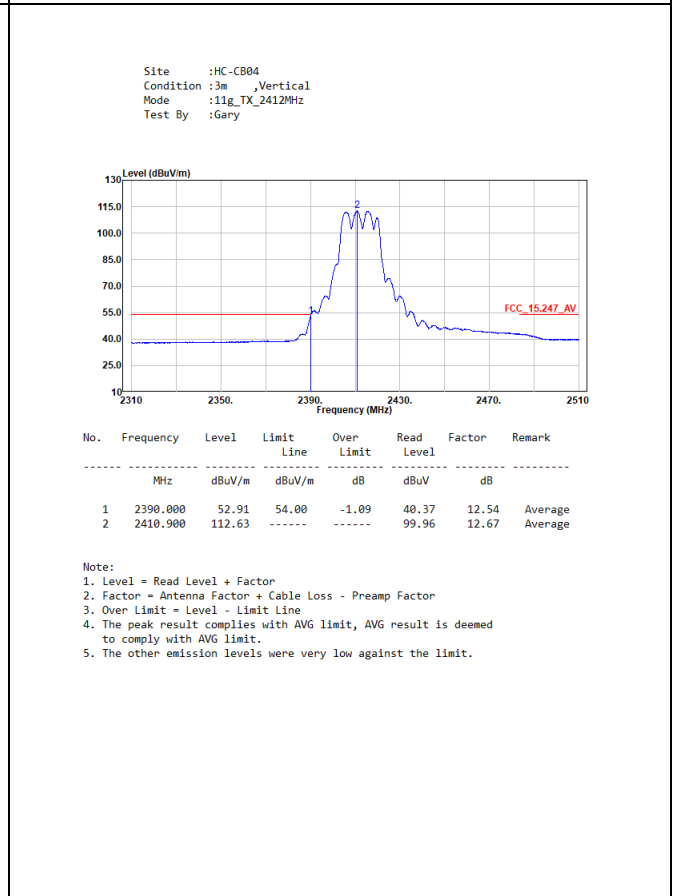
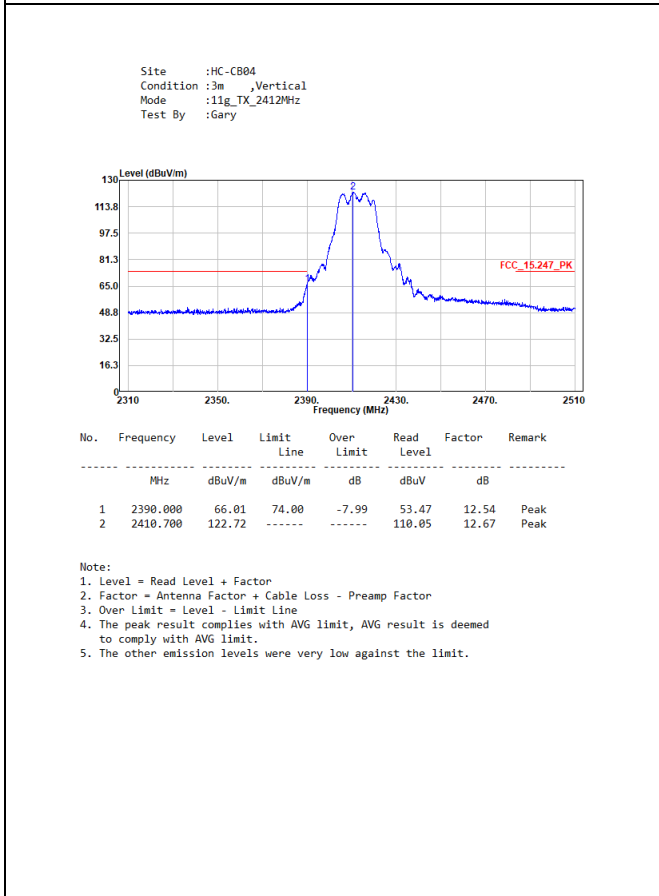
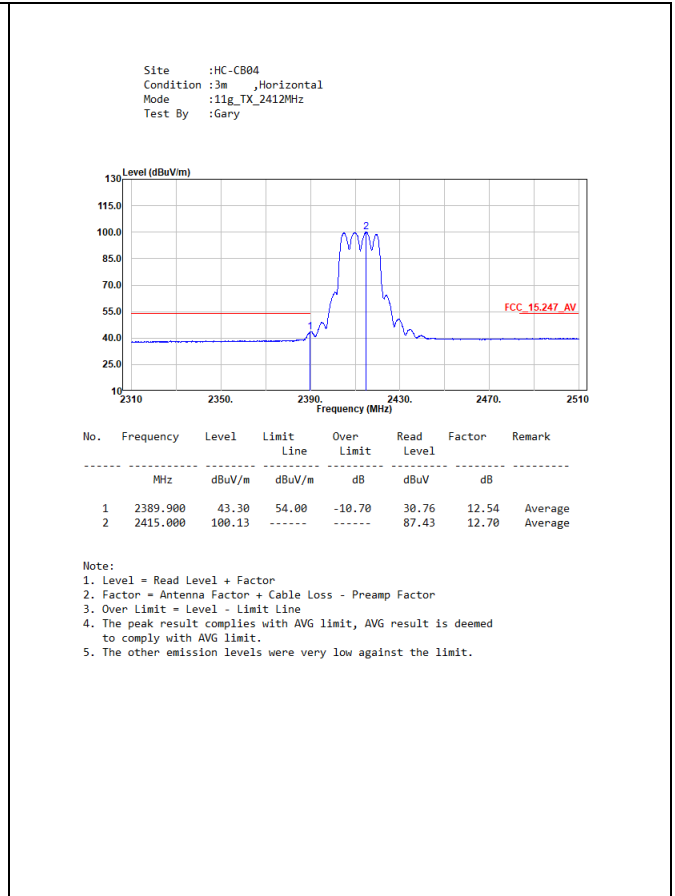
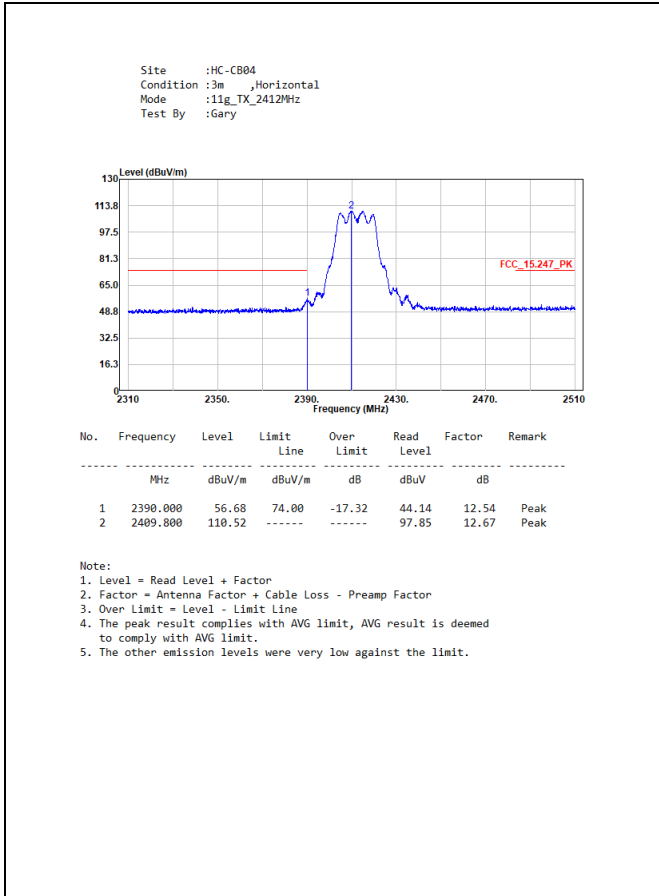

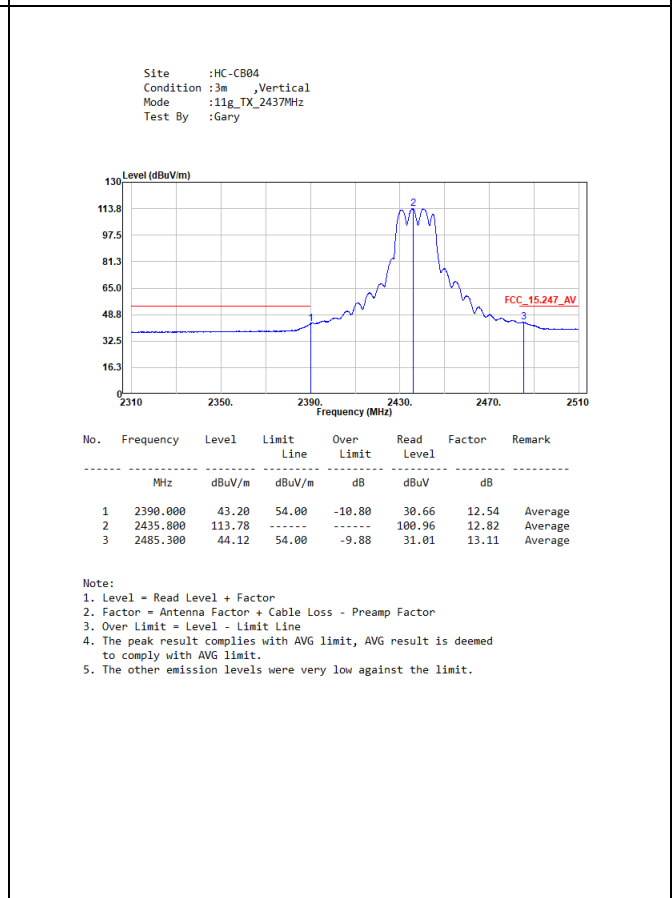
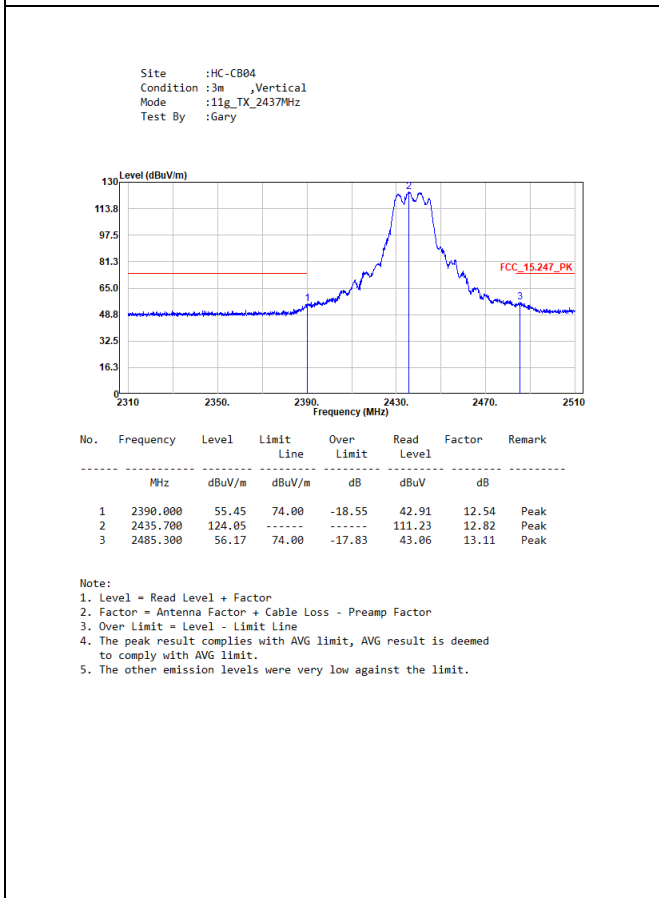
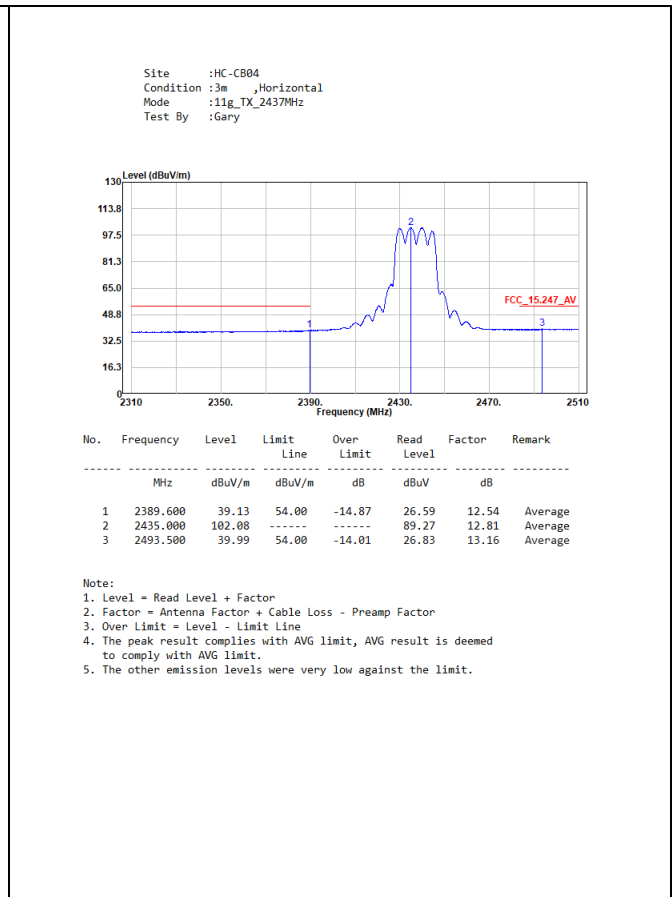
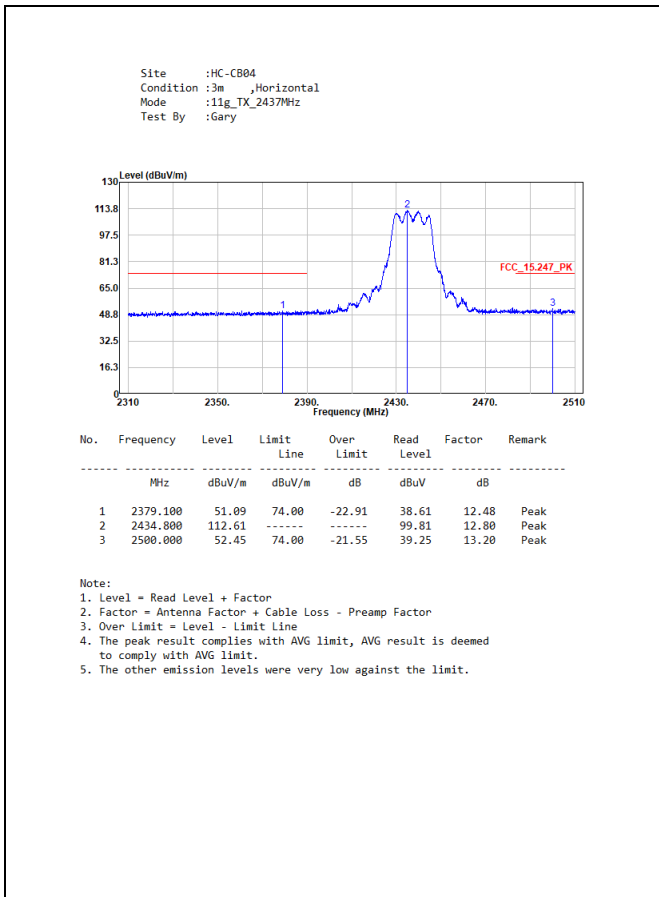

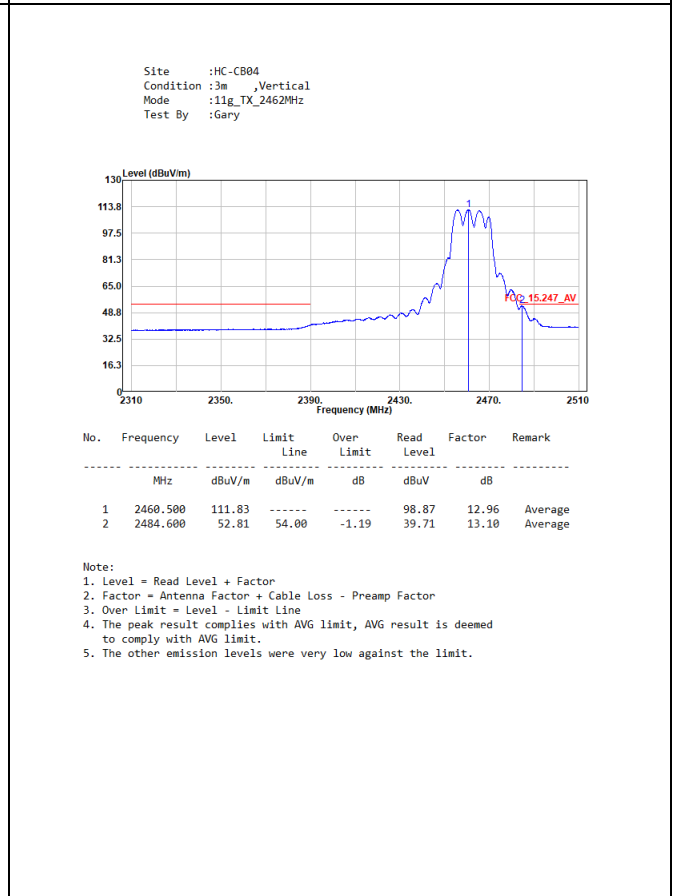
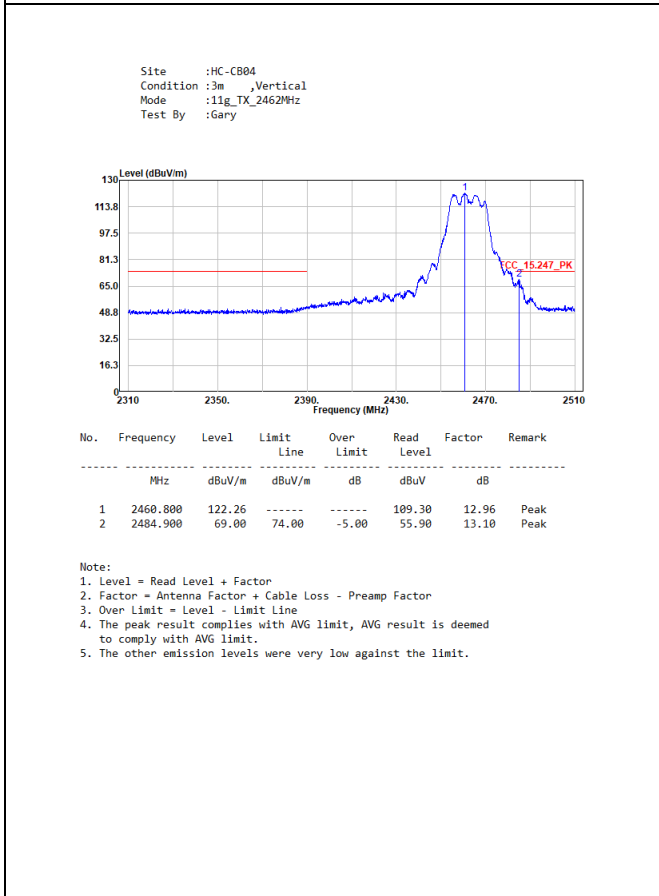
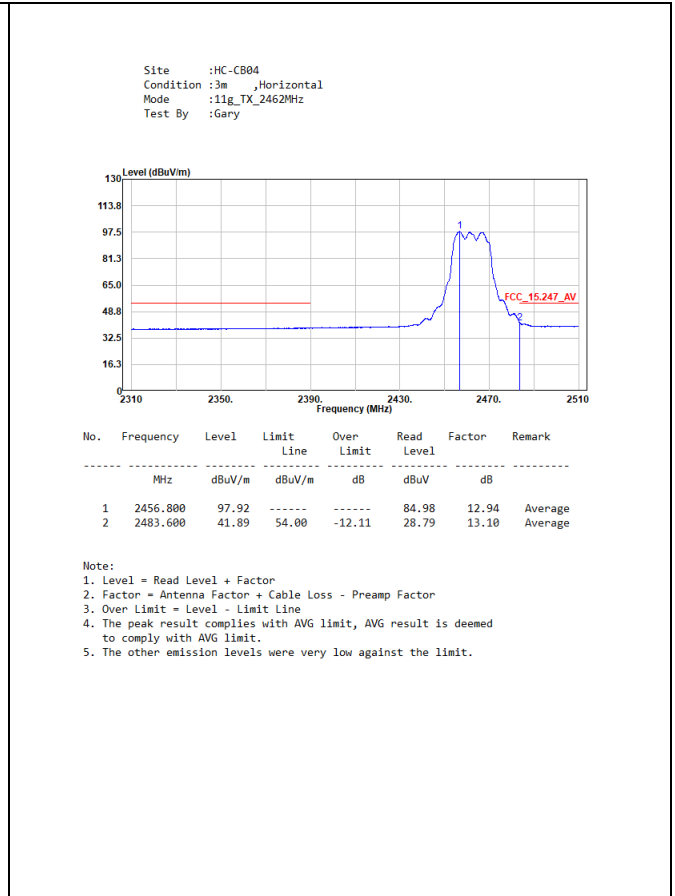
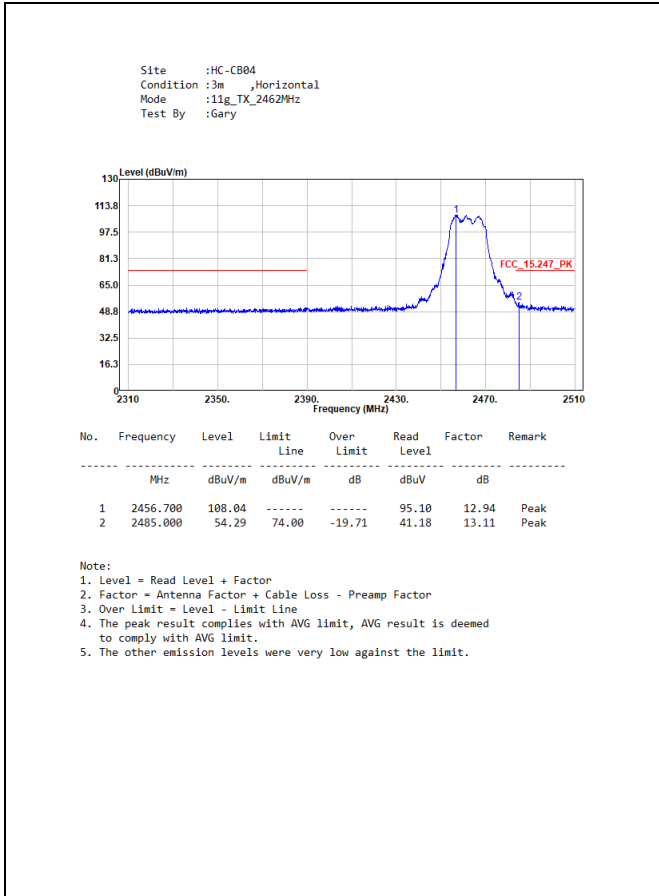

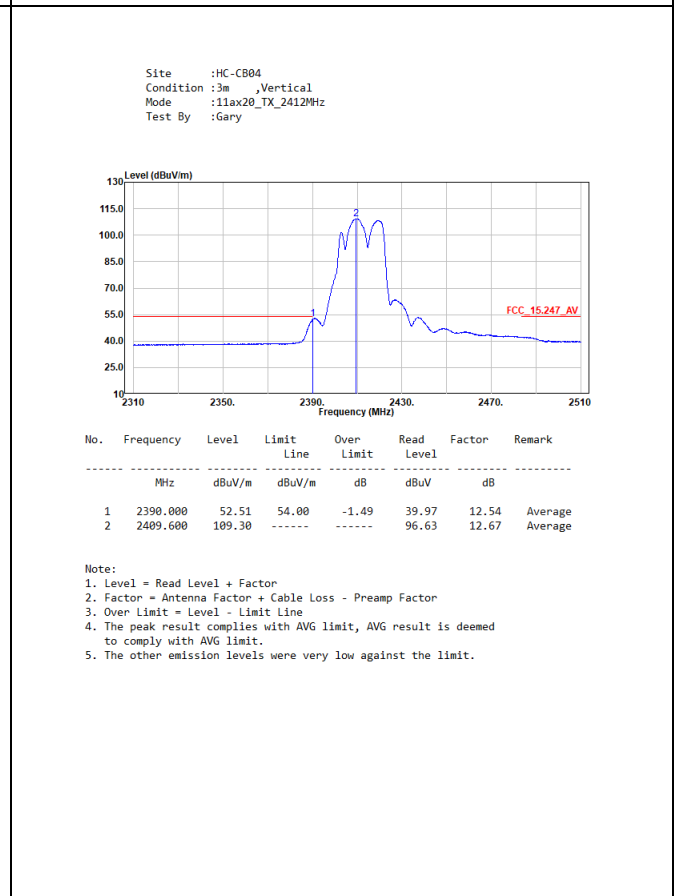
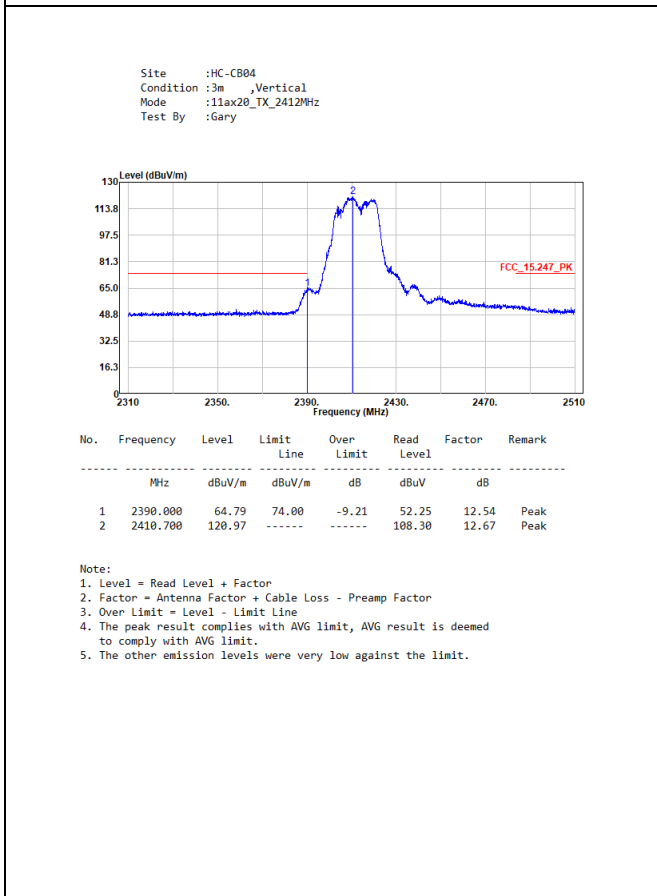
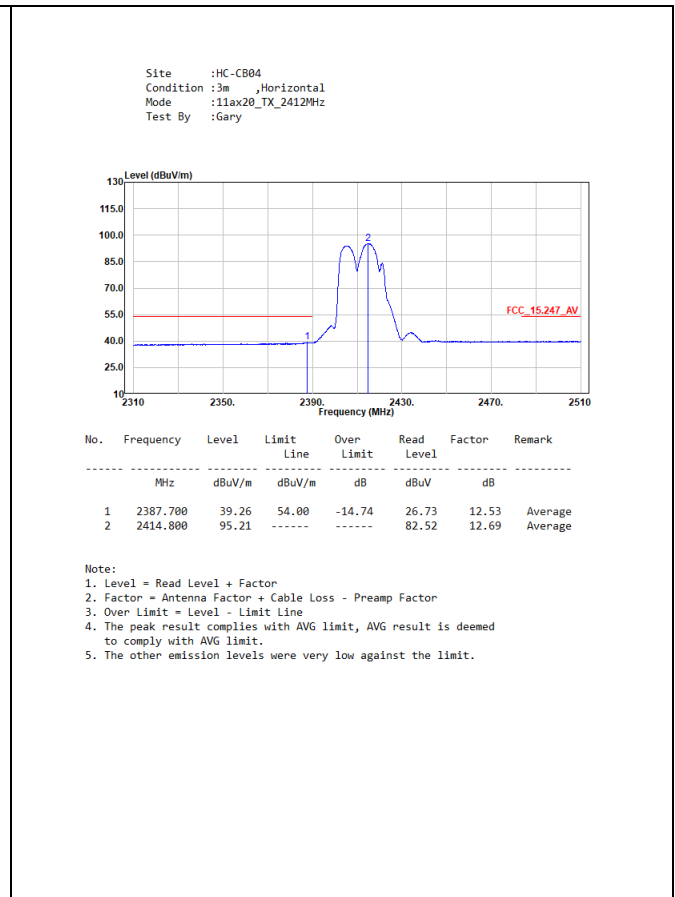
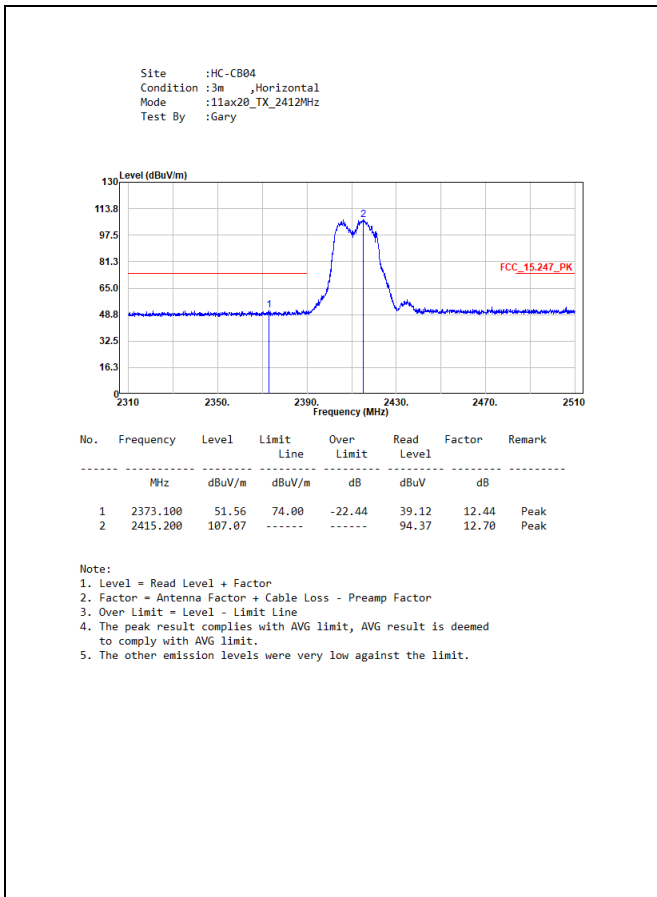

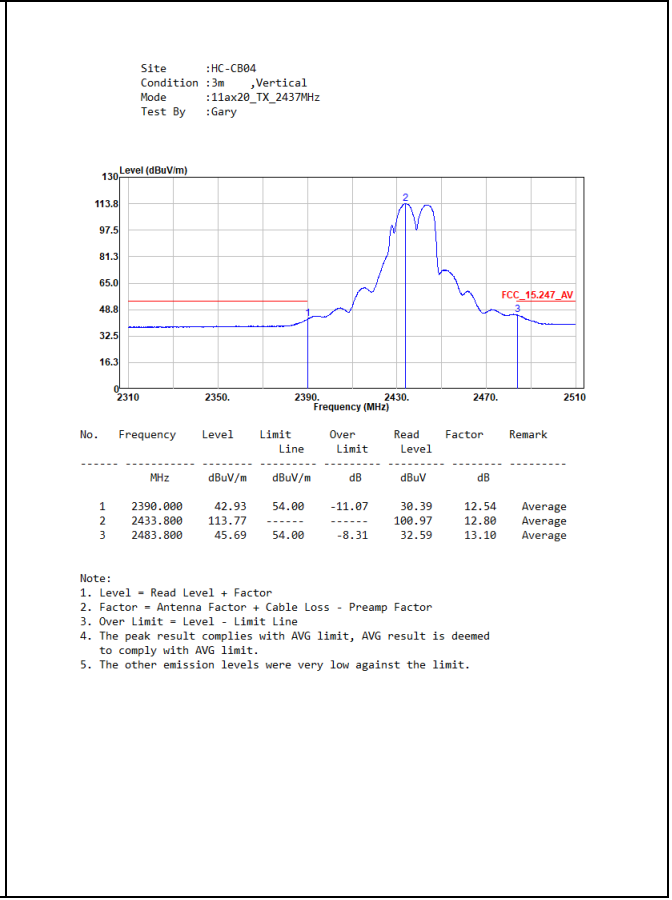
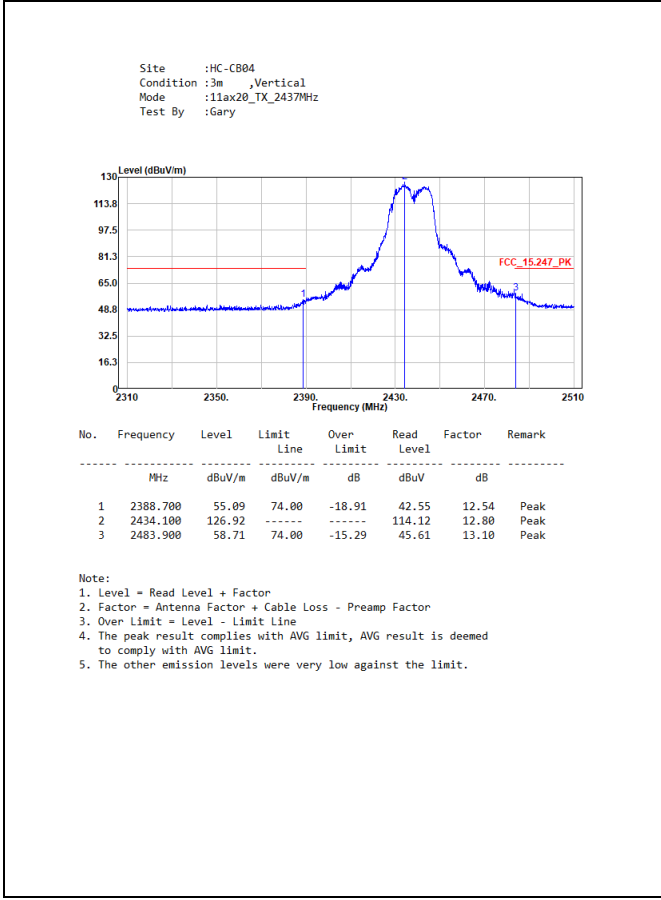
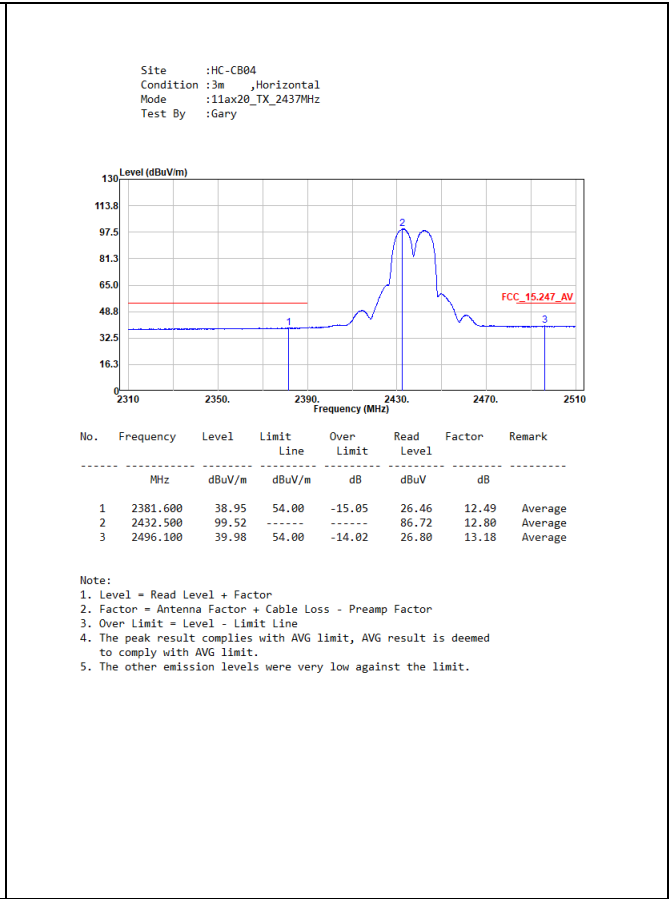
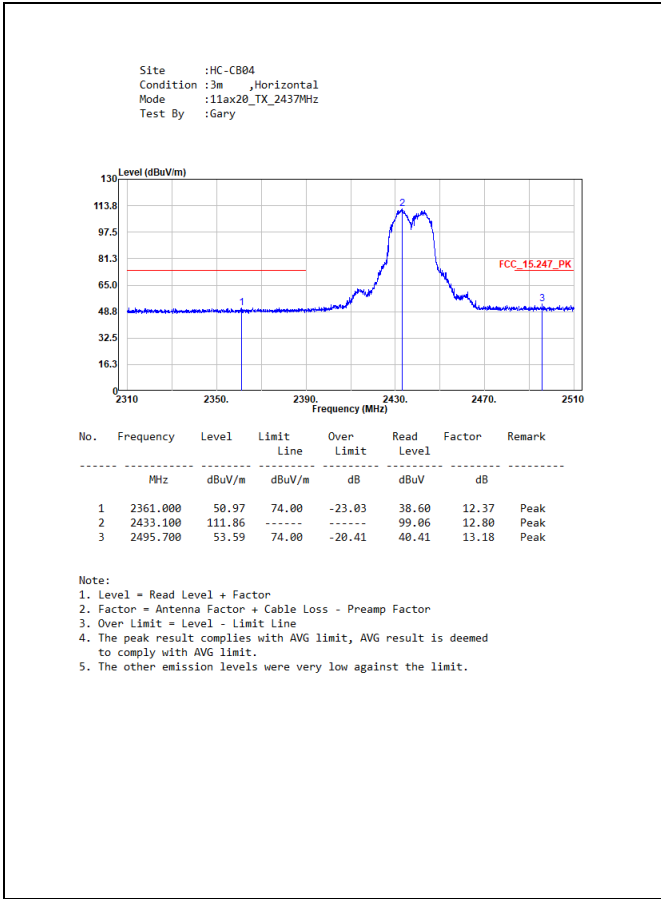

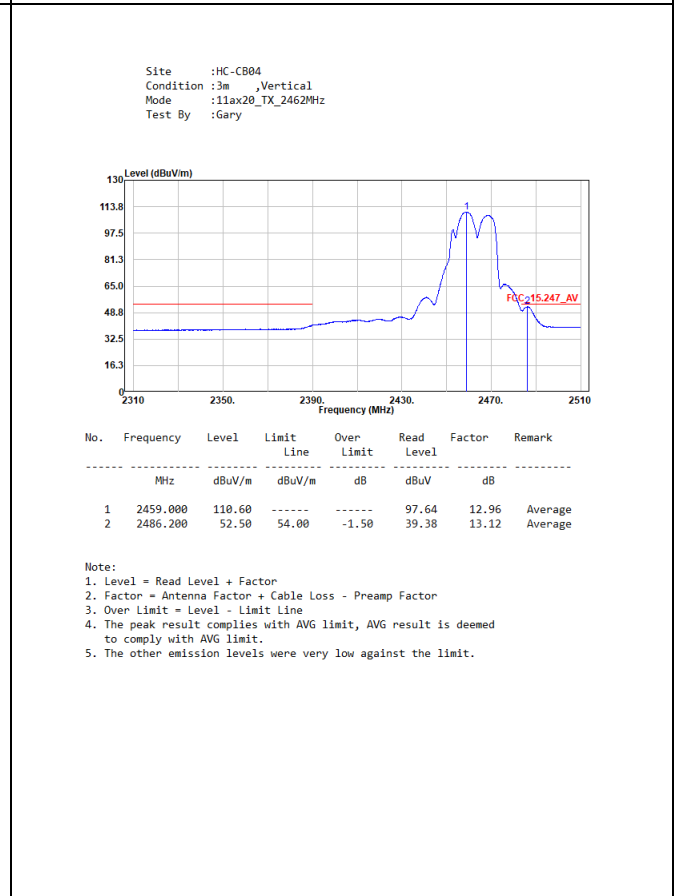
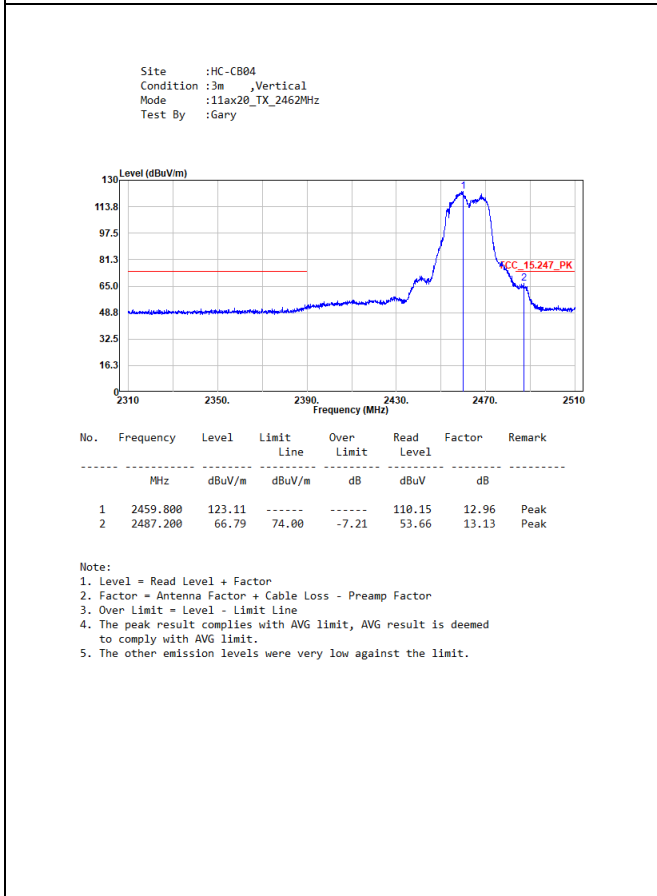
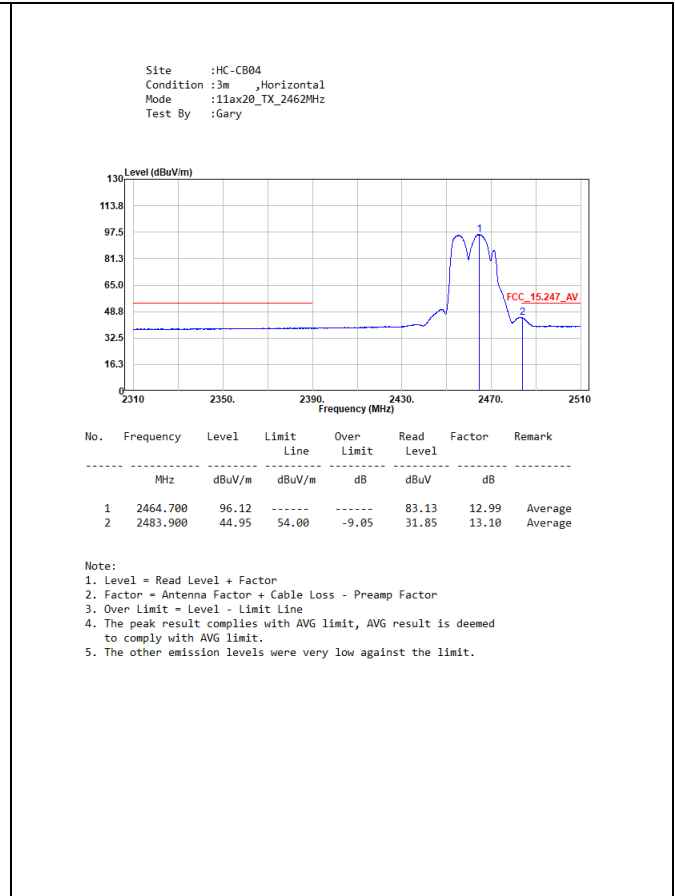
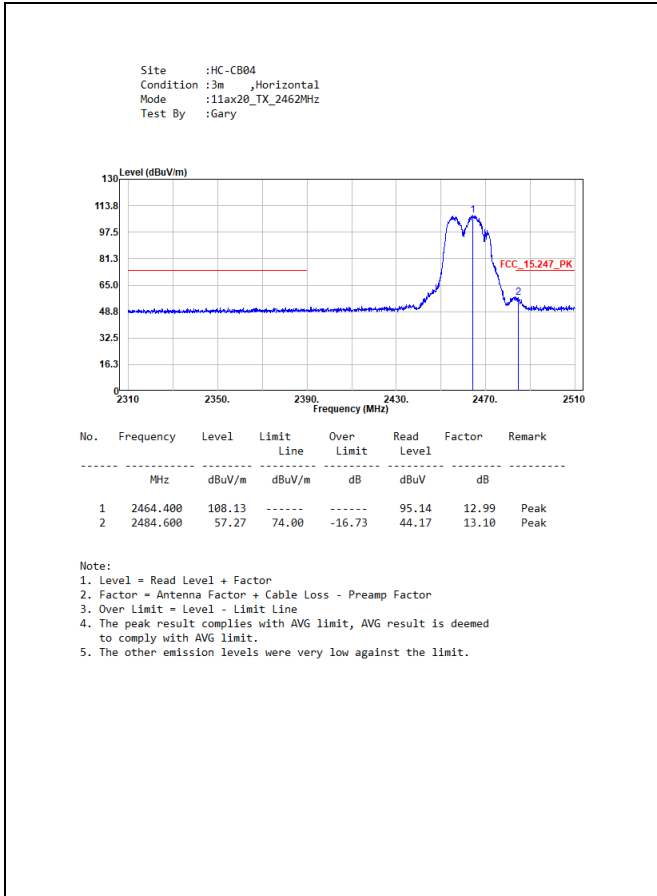

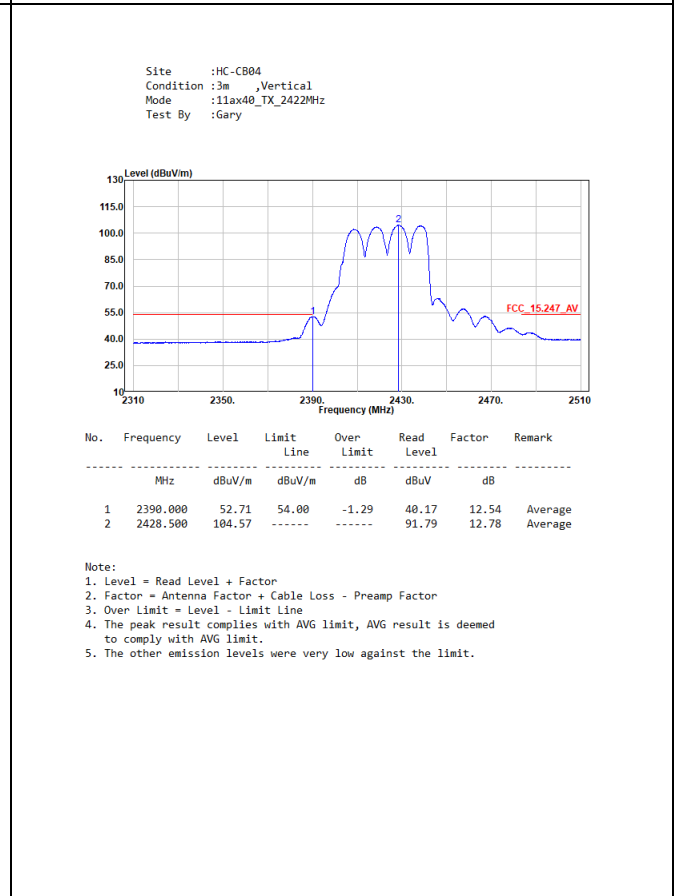
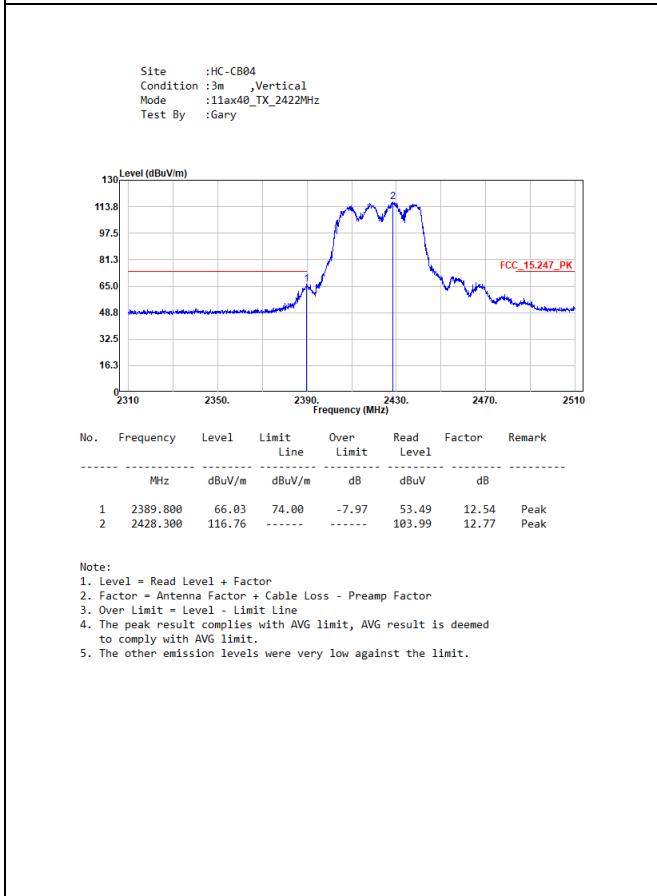
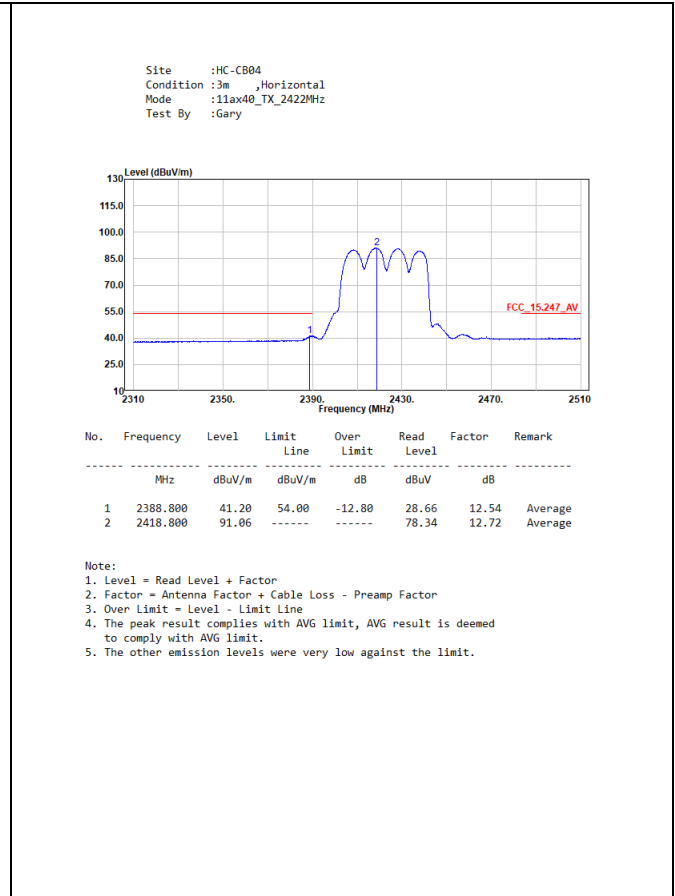
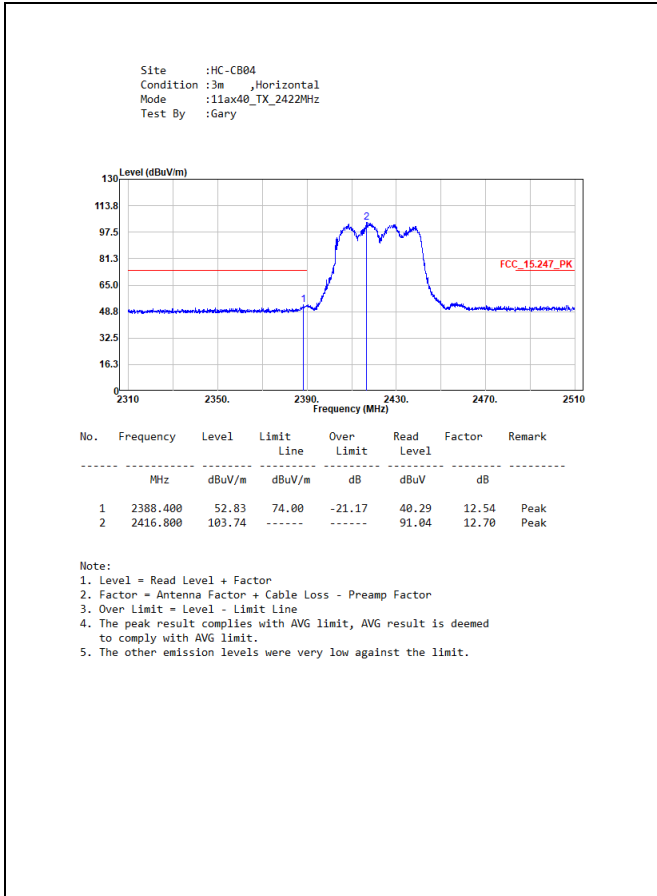

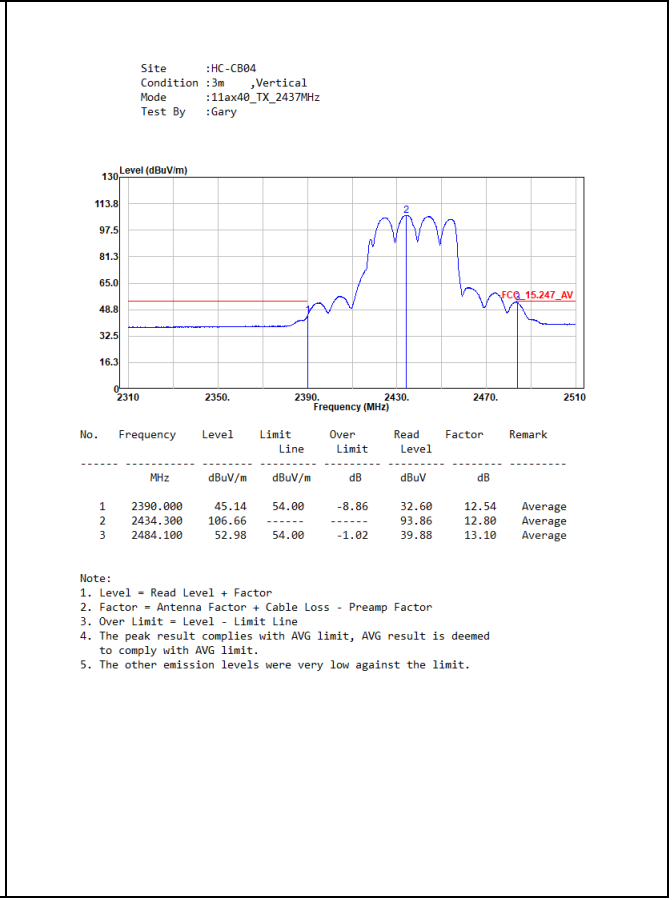
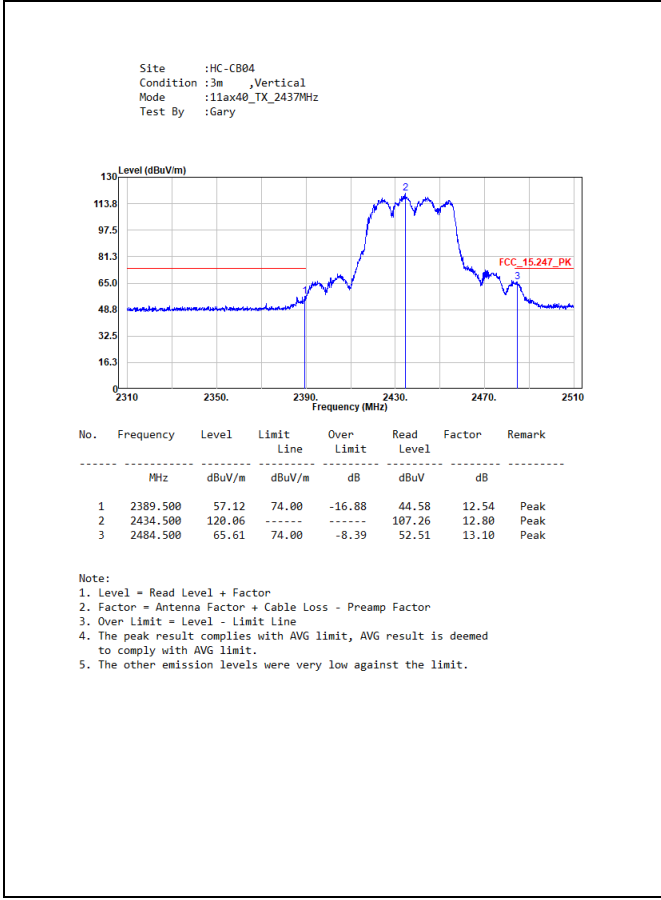
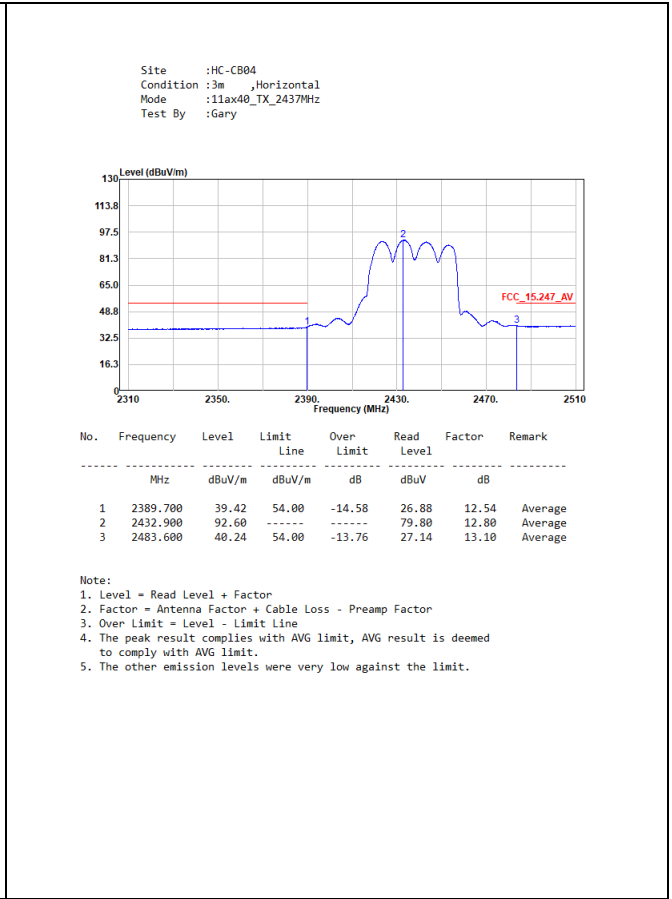
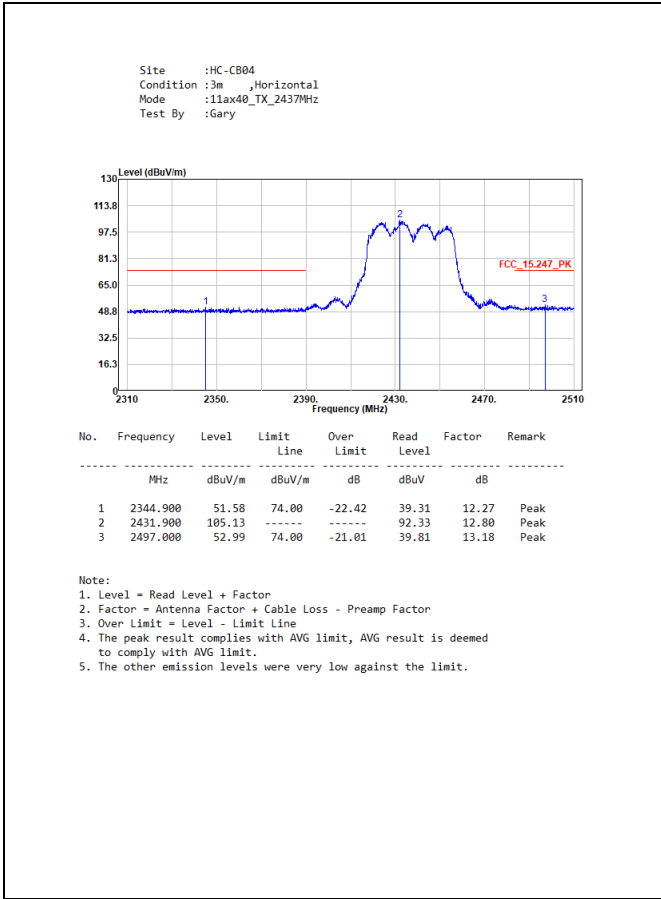

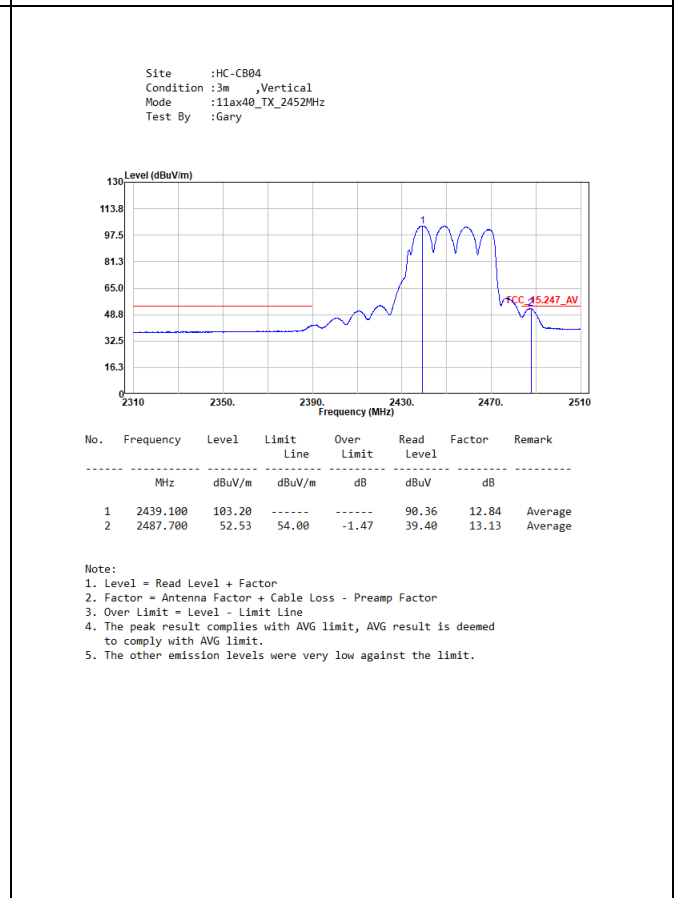
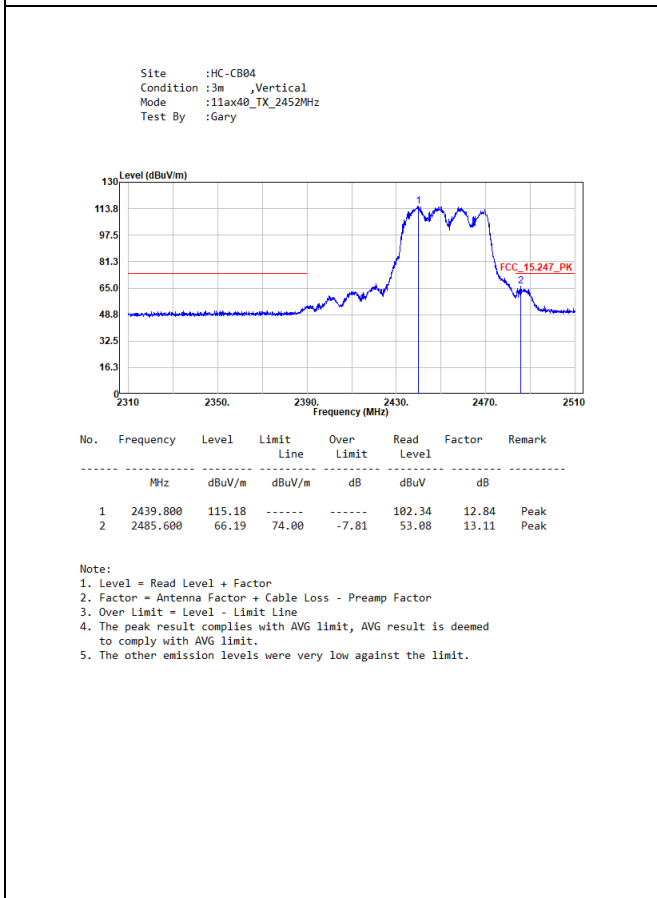
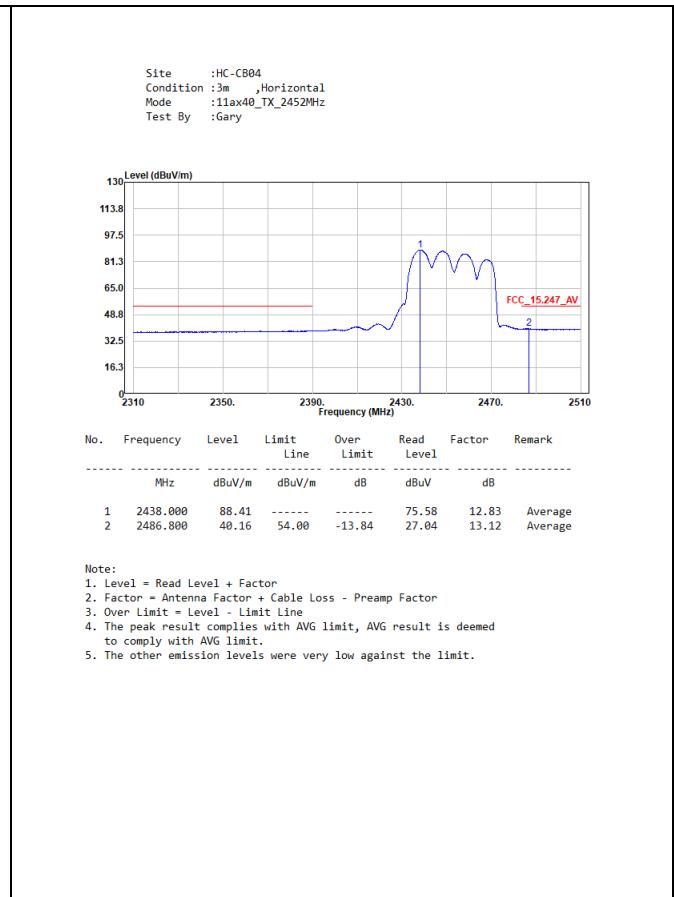
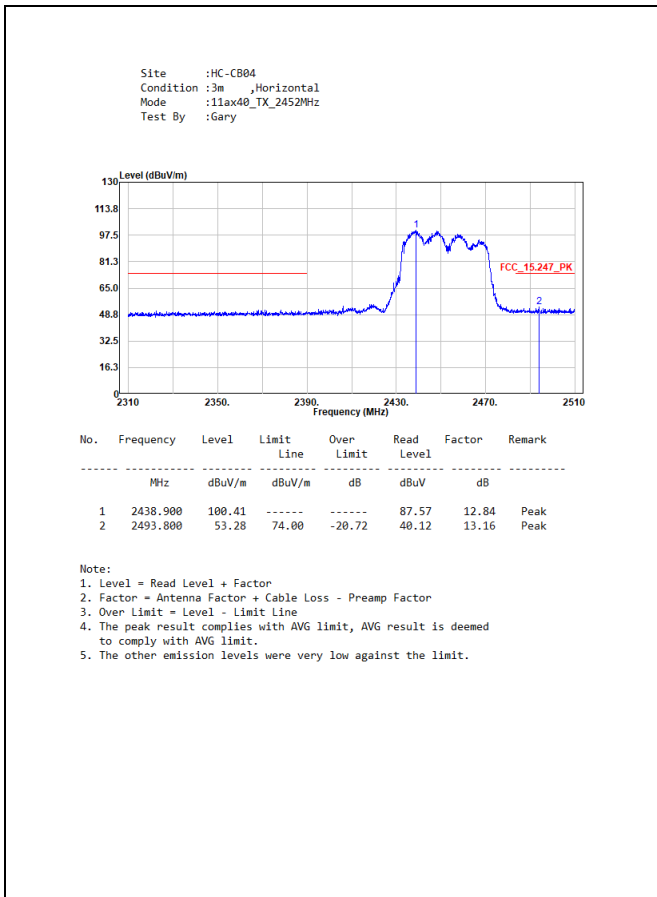

7. Occupied Bandwidth & DTS Bandwidth

7.1. Test Setup

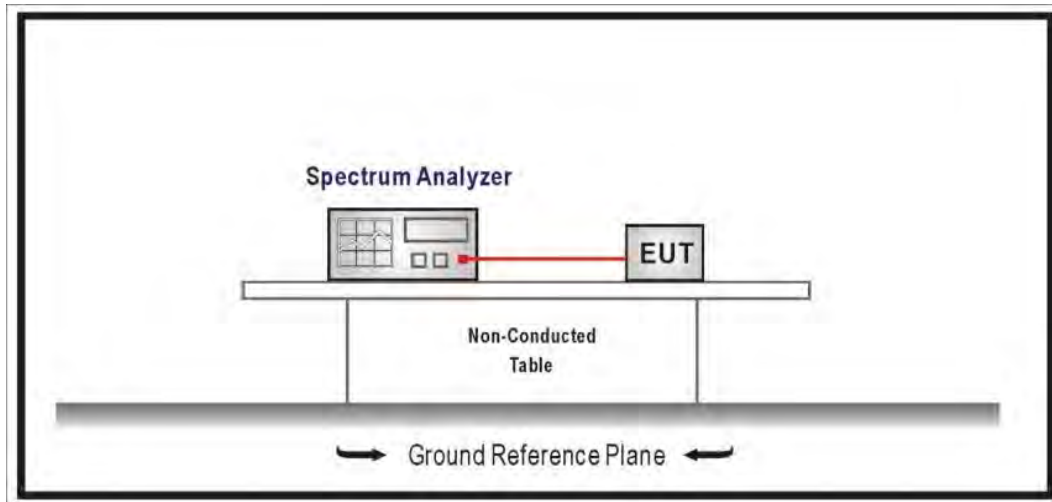

7.2. Test Limit

The 6 dB bandwidth: ≥ 0.50 MHz.

Occupied Bandwidth: NA

7.3. Test Procedures

The EUT was setup according to ANSI C63.10: 2013; tested according to DTS test procedure of KDB 558074 D01 V05r02 for compliance to FCC 47CFR 15.247 requirements.

7.4. Test Specification

According to FCC Part 15 Subpart C Paragraph 15.247.

7.5. Test Result of Occupied Bandwidth

Modulation	Channel	Frequency (MHz)	Occupied Bandwidth (MHz)		Limit (MHz)
			Ant. 0	Ant. 1	
802.11b	1	2412	12.907	12.867	-
	6	2437	12.987	12.867	-
	11	2462	12.947	13.026	-
802.11g	1	2412	16.463	16.423	-
	6	2437	16.423	16.423	-
	11	2462	16.463	16.463	-
802.11ax (20 MHz)	1	2412	18.981	18.901	-
	6	2437	18.941	18.941	-
	11	2462	18.941	18.941	-
802.11ax (40 MHz)	3	2422	37.962	37.882	-
	6	2437	37.882	37.882	-
	9	2452	37.802	38.041	-

Spectrum plot of maximum value

802.11b / Ant. 1 / 2462 MHz

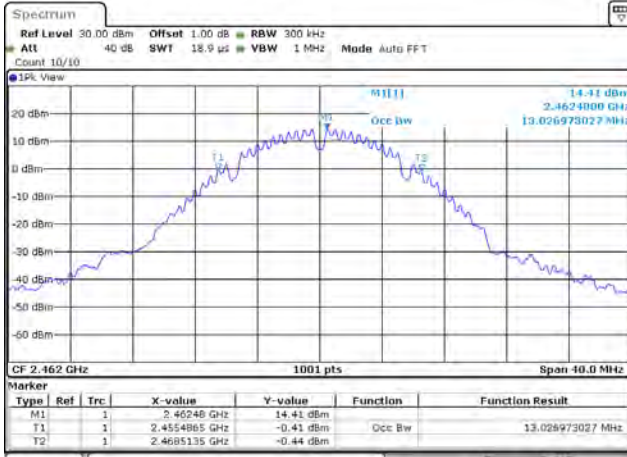

Date: 8.AUG.2022 10:55:13

802.11g / Ant. 0 / 2412 MHz

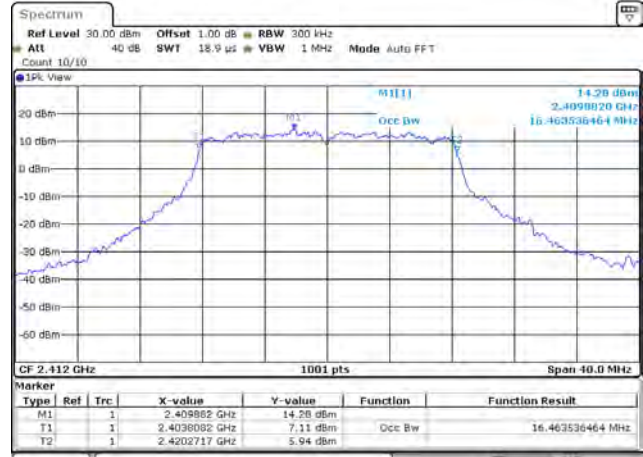

Date: 8.AUG.2022 17:08:51

802.11ax (20 MHz) / Ant. 0 / 2412 MHz

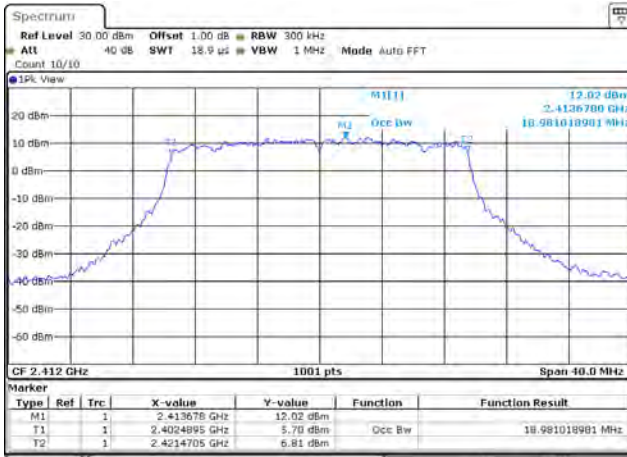

Date: 28.JUL.2022 13:51:43

802.11ax (40 MHz) / Ant. 1 / 2452 MHz

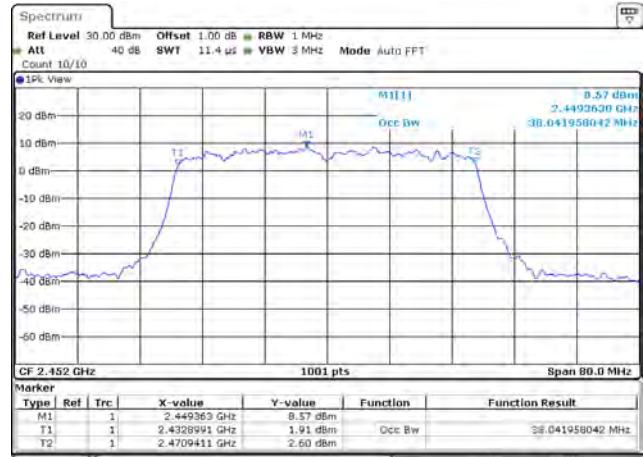

Date: 28.JUL.2022 14:30:30

7.6. Test Result of DTS Bandwidth

Modulation	Channel	Frequency (MHz)	DTS Bandwidth (MHz)		Limit (MHz)	Result
			Ant. 0	Ant. 1		
802.11b	1	2412	8.032	8.032	≥ 0.50	Pass
	6	2437	8.071	8.032	≥ 0.50	Pass
	11	2462	8.032	8.032	≥ 0.50	Pass
802.11g	1	2412	15.624	15.664	≥ 0.50	Pass
	6	2437	15.864	15.984	≥ 0.50	Pass
	11	2462	15.784	16.263	≥ 0.50	Pass
802.11ax (20 MHz)	1	2412	18.341	16.463	≥ 0.50	Pass
	6	2437	18.022	16.943	≥ 0.50	Pass
	11	2462	17.982	17.062	≥ 0.50	Pass
802.11ax (40 MHz)	3	2422	37.802	37.642	≥ 0.50	Pass
	6	2437	37.242	37.322	≥ 0.50	Pass
	9	2452	37.882	37.642	≥ 0.50	Pass

Spectrum plot of worst value

802.11b / Ant. 0 / 2412 MHz

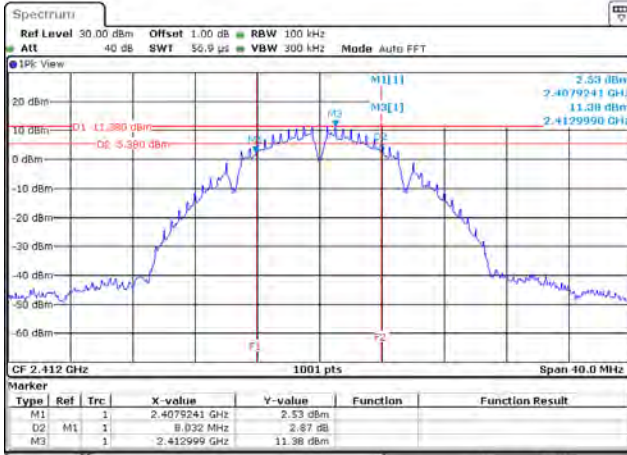

Date: 28.JUL.2022 11:35:56

802.11g / Ant. 0 / 2412 MHz

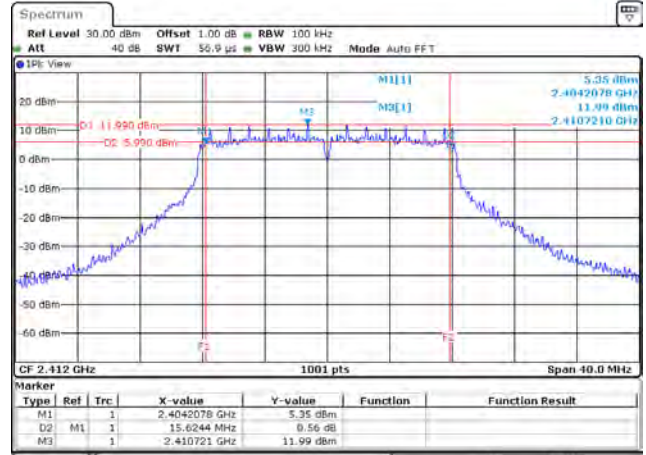

Date: 8.AUG.2022 17:05:59

802.11ax (20 MHz) / Ant. 1 / 2412 MHz

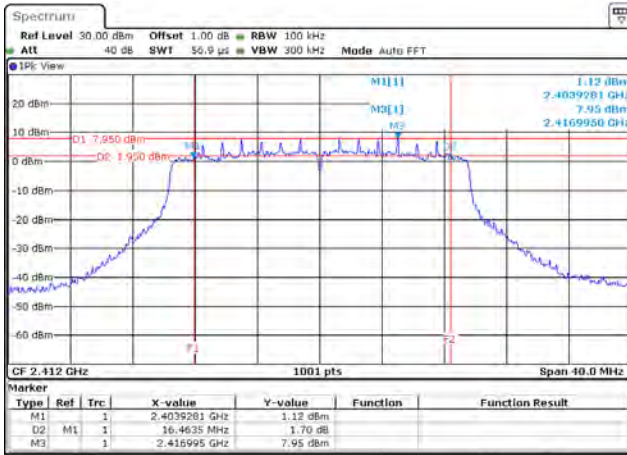

Date: 28.JUL.2022 14:00:14

802.11ax (40 MHz) / Ant. 0 / 2437 MHz

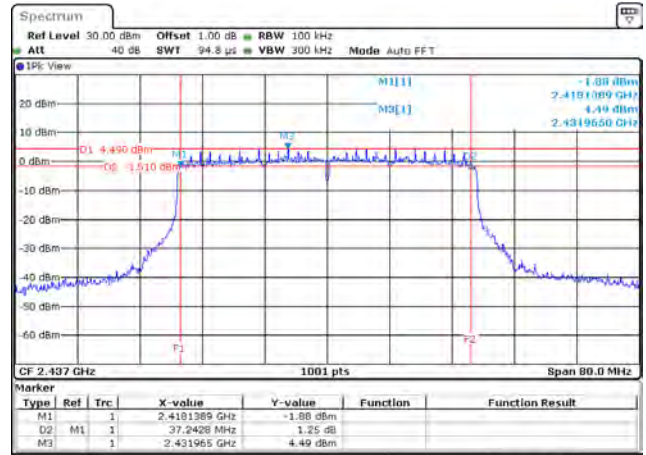

Date: 8.AUG.2022 17:20:46

8. Maximum Power Spectral Density

8.1. Test Setup

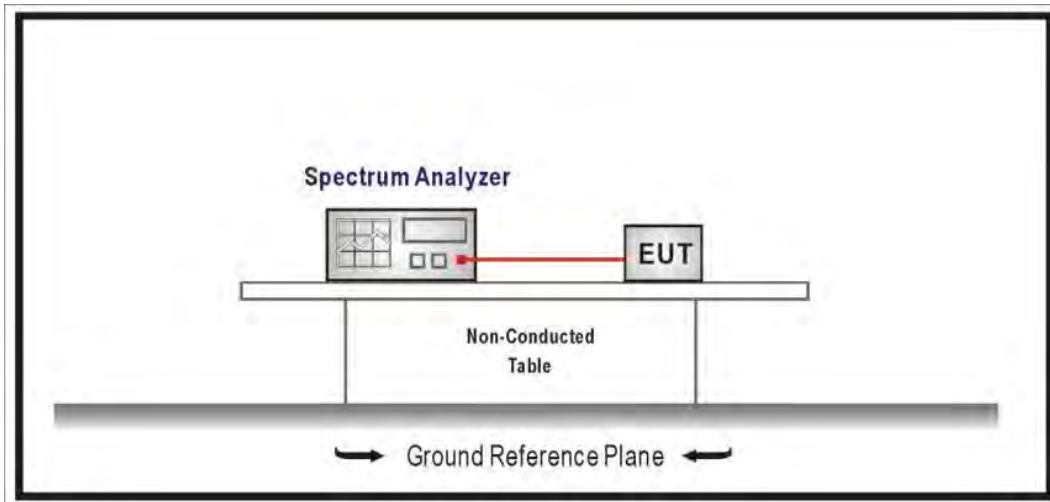

8.2. Test Limit

The peak power spectral density conducted from the intentional radiated to the antenna shall not be greater than +8 dBm in any 3 kHz band during any time interval of continuous transmission.

8.3. Test Procedures

The EUT was setup according to ANSI C63.10: 2013; tested according to DTS test procedure of KDB 558074 D01 V05r02 for compliance to FCC 47CFR 15.247 requirements.

8.4. Test Specification

According to FCC Part 15 Subpart C Paragraph 15.247.

8.5. Test Result of Maximum Power Spectral Density

Modulation	Channel	Frequency (MHz)	Power Spectral Density (dBm / 3kHz)			Limit (dBm / 3kHz)	Result
			Ant. 0	Ant. 1	Total		
802.11b	1	2412	-6.330	-7.310	-0.927	≤ 8.00	Pass
	6	2437	-3.410	-3.340	2.490	≤ 8.00	Pass
	11	2462	-1.960	-3.630	3.150	≤ 8.00	Pass
802.11g	1	2412	-6.630	-7.120	-3.507	≤ 8.00	Pass
	6	2437	-6.360	-6.690	-3.160	≤ 8.00	Pass
	11	2462	-7.960	-9.320	-5.226	≤ 8.00	Pass
802.11ax (20 MHz)	1	2412	-11.350	-13.080	-8.916	≤ 8.00	Pass
	6	2437	-8.070	-8.330	-4.984	≤ 8.00	Pass
	11	2462	-10.840	-11.270	-7.836	≤ 8.00	Pass
802.11ax (40 MHz)	3	2422	-16.780	-16.930	-13.641	≤ 8.00	Pass
	6	2437	-15.270	-15.690	-12.262	≤ 8.00	Pass
	9	2452	-18.260	-19.920	-15.798	≤ 8.00	Pass

Note: Total power spectral density = power spectral density + duty factor, and the duty factor refer to section 1.10.

Spectrum plot of worst value

802.11b / Ant. 0 / 2462 MHz

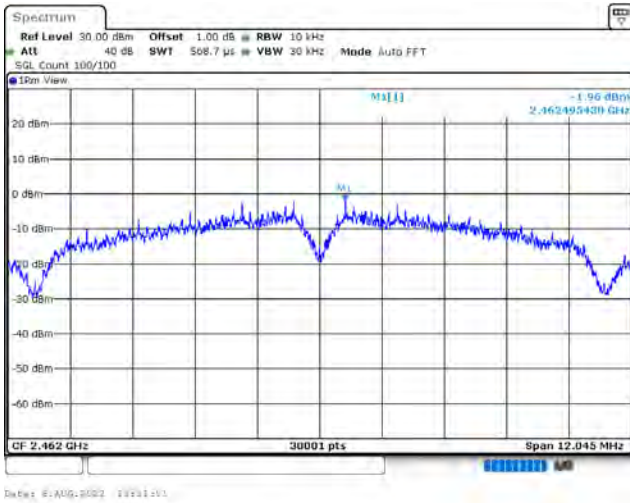

802.11g / Ant. 0 / 2437 MHz

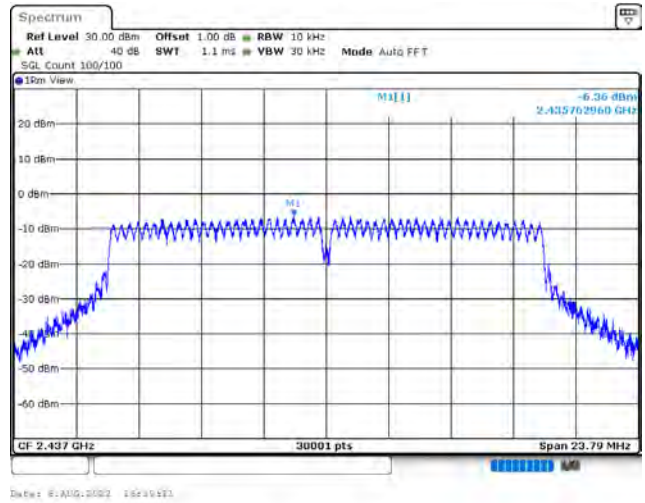

802.11ax (20 MHz) / Ant. 0 / 2437 MHz

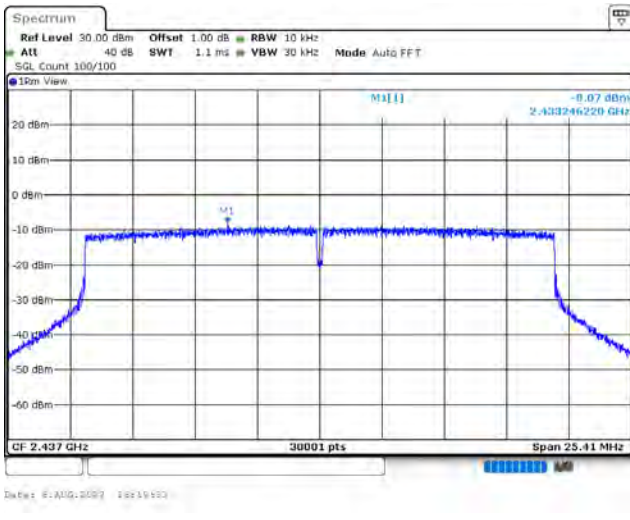

802.11ax (40 MHz) / Ant. 0 / 2437 MHz

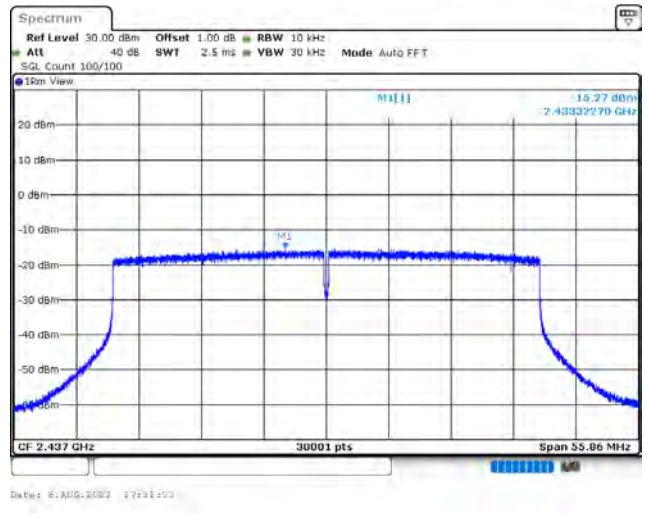

Appendix A

➤ Test Result of Radiated Emissions Co-location

1. WiFi 2.4 GHz function + WiFi 5 GHz function + WWAN WCDMA function 30 MHz ~ 1 GHz:



Above 1 GHz:

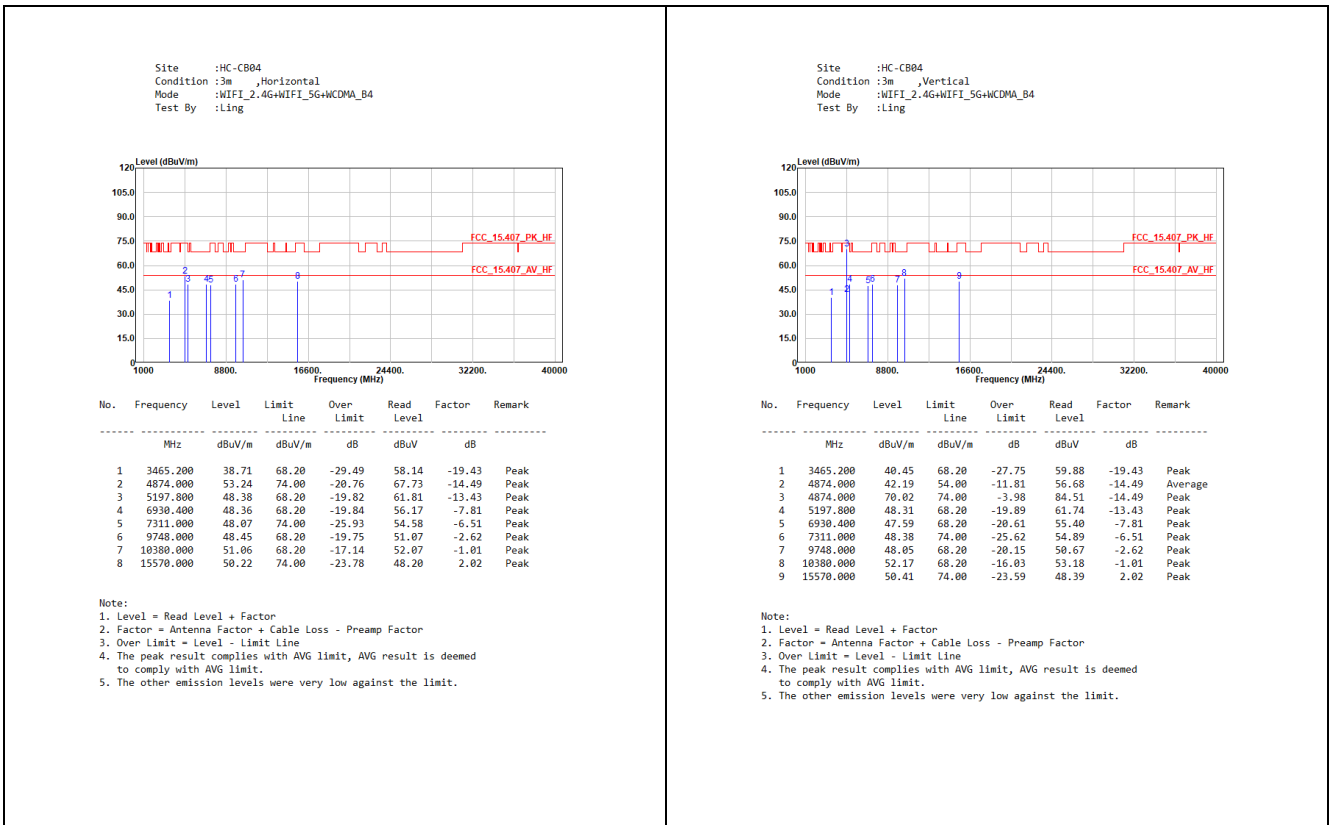

**2. WiFi 2.4 GHz function + WiFi 5 GHz function + WWAN LTE function
30 MHz ~ 1 GHz:**

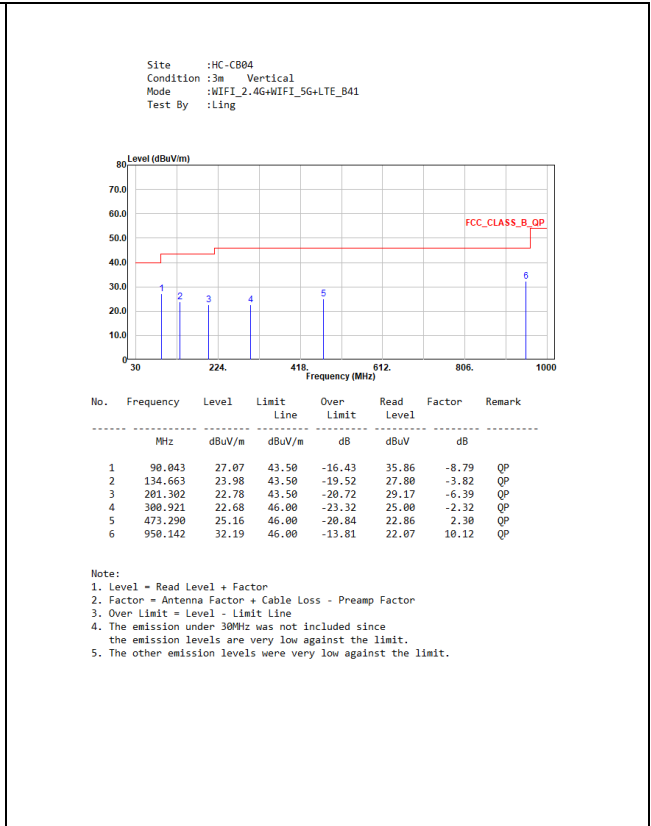
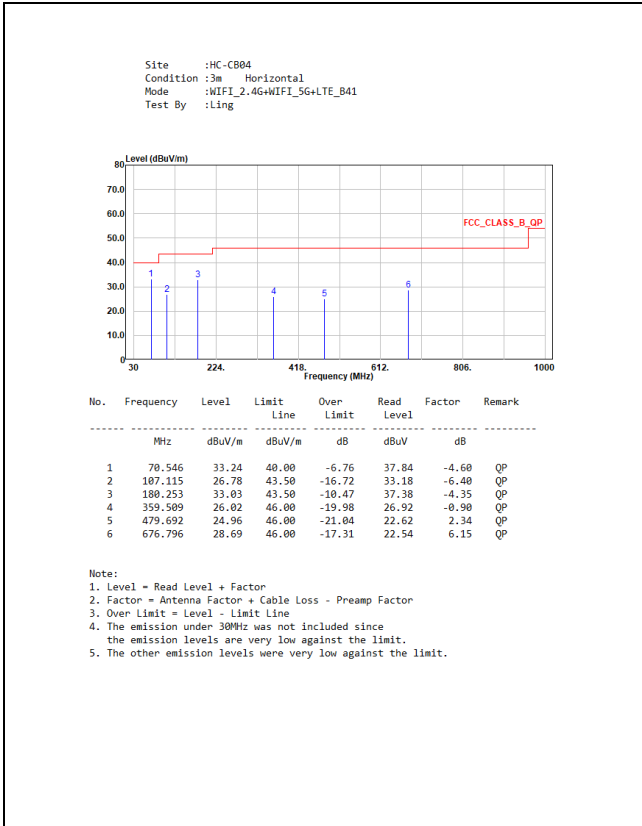

Above 1 GHz:

