



Variant FCC RF Test Report

APPLICANT : Pismo Labs Technology Limited

EQUIPMENT : Pepwave/Peplink/Pismo Labs Wireless Product

BRAND NAME : Pepwave / Peplink / Pismo

MODEL NAME : MAX Transit
MAX Transit LTE
MAX Transit LTEA
MAX transit with Content Hub (MAX-TST-CHBA-E-T,
MAX-TST-CHBB-E-T, MAX-TST-CHBC-E-T)
MAX Transit with M12 Connector
MAX Transit with ContentHub with M12 connector
MAX Transit with Content Hub with M12 connector
MAX Transit LTEA with M12 Connector
MAX Transit LTEA with ContentHub with M12 connector
MAX Transit LTEA with Content Hub with M12 connector
Pismo813
Pismo 813
MAX Transit Quad
MAX Transit Quad LTE
MAX Transit Quad LTEA
MAX Transit Duo
MAX Transit Duo LTE
MAX Transit Duo LTEA
MAX Transit Duo with M12 Connector
MAX Transit Duo with ContentHub with M12 connector
MAX Transit Duo with Content Hub with M12 connector
MAX Transit Duo LTEA with M12 Connector
MAX Transit Duo LTEA with ContentHub with M12 connector
MAX Transit Duo LTEA with Content Hub with M12 connector
Pismo813M12
Pismo 813M12
(for more details please refer to section 1.3)

FCC ID : U8G-P1813

STANDARD : FCC Part 15 Subpart C §15.247

CLASSIFICATION : (DTS) Digital Transmission System



The product was received on Feb. 05, 2018 and testing was completed on Feb. 14, 2018. We, SPORTON INTERNATIONAL INC., would like to declare that the tested sample has been evaluated in accordance with the test procedures and has been in compliance with the applicable technical standards.

The test results in this report apply exclusively to the tested model / sample. Without written approval of SPORTON INTERNATIONAL INC., the test report shall not be reproduced except in full.

Reviewed by: Joseph Lin / Supervisor

Approved by: Jones Tsai / Manager



SPORTON INTERNATIONAL INC.

No. 52, Hwa Ya 1st Rd., Hwa Ya Technology Park, Kwei-Shan District, Tao Yuan City, Taiwan, R.O.C.



TABLE OF CONTENTS

1 GENERAL DESCRIPTION 6

1.1 Applicant 6

1.2 Manufacturer 6

1.3 Product Feature of Equipment Under Test 6

1.4 Product Specification of Equipment Under Test 9

1.5 Modification of EUT 9

1.6 Testing Location 9

1.7 Applicable Standards 9

2 TEST CONFIGURATION OF EQUIPMENT UNDER TEST 10

2.1 Carrier Frequency and Channel 10

2.2 Test Mode 11

2.3 Connection Diagram of Test System 12

2.4 Support Unit used in test configuration and system 13

2.5 EUT Operation Test Setup 13

3 TEST RESULT 14

3.1 Radiated Band Edges and Spurious Emission Measurement 14

3.2 AC Conducted Emission Measurement 18

4 LIST OF MEASURING EQUIPMENT 22

5 UNCERTAINTY OF EVALUATION 23

APPENDIX A. RADIATED SPURIOUS EMISSION

APPENDIX B. SETUP PHOTOGRAPHS



REVISION HISTORY

REPORT NO.	VERSION	DESCRIPTION	ISSUED DATE
FR820530A	Rev. 01	Initial issue of report	Apr. 25, 2018



SUMMARY OF TEST RESULT

Report Section	FCC Rule	Description	Limit	Result	Remark
-	15.247(a)(2)	6dB Bandwidth	≥ 0.5MHz	Not Required	-
-	-	99% Bandwidth	-	Not Required	-
-	15.247(b)	Power Output Measurement	≤ 30dBm	Not Required	-
-	15.247(e)	Power Spectral Density	≤ 8dBm/3kHz	Not Required	-
-	15.247(d)	Conducted Band Edges	≤ 20dBc	Not Required	-
		Conducted Spurious Emission		Not Required	-
3.1	15.247(d)	Radiated Band Edges and Radiated Spurious Emission	15.209(a) & 15.247(d)	Pass	Under limit 1.93 dB at 4924.000 MHz
3.2	15.207	AC Conducted Emission	15.207(a)	Pass	Under limit 0.42 dB at 2.980 MHz
-	15.203 & 15.247(b)	Antenna Requirement	N/A	Pass	-

Remark: Not Required means the change does not affect the test result.



1 General Description

1.1 Applicant

Pismo Labs Technology Limited

Flat A5, 5/F HK Spinners Ind. Bldg., Phase 6, 481 Castle Peak Road, Cheung Sha Wan, Kowloon, Hong Kong

1.2 Manufacturer

Pismo Labs Technology Limited

Flat A5, 5/F HK Spinners Ind. Bldg., Phase 6, 481 Castle Peak Road, Cheung Sha Wan, Kowloon, Hong Kong

1.3 Product Feature of Equipment Under Test

Product Feature	
Equipment	Pepwave/Peplink/Pismo Labs Wireless Product
Brand Name	Pepwave / Peplink / Pismo
Model Name	Please refer to remark 3 below which list all model names
FCC ID	U8G-P1813
EUT supports Radios application	WLAN 2.4GHz 802.11b/g/n HT20/HT40
Power Supply Rating	12-56Vdc from power adapter or 12-56Vdc from Terminal Block
HW Version	3
SW Version	7.0.3
EUT Stage	Identical Prototype

Remark:

1. The above EUT's information was declared by manufacturer. Please refer to the specifications or user's manual for more detailed description.
2. Based on the similarity between current and previous project, only the worst cases of RSE from original test report (BV Report Number "RF150713E08") and conduction item were verified for the differences.



3. This is a variant report changing non-RF component and adding serial models for FCC class II permissive change. The difference compared with the original report design is as the following table:

Brand	Product Name	Model Name	Difference	
Pepwave / Peplink / Pismo	Pepwave / Peplink / Pismo Labs Wireless Product	MAX Transit (original)	With one module slot & cellular SIM slot	a. equipped with M12 connector and the M12 connector board's size is larger b. has an extension board (Piggy board) added with 2 PCIE slots
		MAX Transit LTE (original)		
		MAX Transit LTEA (original)		
		MAX transit with Content Hub (MAX-TST-CHBA-E-T, MAX-TST-CHBB-E-T, MAX-TST-CHBC-E-T) (original)		
		MAX Transit with M12 Connector		
		MAX Transit with ContentHub with M12 connector		
		MAX Transit with Content Hub with M12 connector		
		MAX Transit LTEA with M12 Connector		
		MAX Transit LTEA with ContentHub with M12 connector		
		MAX Transit LTEA with Content Hub with M12 connector		
		Pismo813	With two module slots & cellular SIM slots	
		Pismo 813 (original)		
		MAX Transit Quad (original)		
		MAX Transit Quad LTE (original)		
		MAX Transit Quad LTEA (original)		
		MAX Transit Duo (original)		
		MAX Transit Duo LTE (original)		
		MAX Transit Duo LTEA (original)		
		MAX Transit Duo with M12 Connector		
		MAX Transit Duo with ContentHub with M12 connector		
MAX Transit Duo with Content Hub with M12 connector				
MAX Transit Duo LTEA with M12 Connector				
MAX Transit Duo LTEA with ContentHub with M12 connector				
MAX Transit Duo LTEA with Content Hub with M12 connector				
Pismo813M12				
Pismo 813M12				

4. The antennas provided to the EUT, please refer to the following table:

For WLAN						
Antenna No.	Band	Model	Ant. Gain (dBi)	Frequency range (GHz to GHz)	Antenna Type	Connecter Type
1	SmartAnt	SAA06-220690	3	2.4~2.4835	Dipole	RP-SMA
			5.5	5.15~5.25		
			6	5.725~5.85		
2	SmartAnt	SAA06-220690	3	2.4~2.4835	Dipole	RP-SMA
			5.5	5.15~5.25		
			6	5.725~5.85		

5. EUT must be supplied with two power adapters as following table:

NO.	Brand Name	Model No.	Spec.
Adapter 1	Ten Pao	S024AMM1200200	Input: 100-240V, 600mA, 50/60Hz Output: 12Vdc, 2A DC output cable: non-shielded, 1.5m with 1 core
Adapter 2	DVE	DSA-24PFM-12 FUS	Input 100-240V ,800mA, 50/60Hz Output: 12 Vdc, 2,0 A DC output cable: non-shielded, 1.5m without core

6. The EUT was pre-tested under the following test modes:

Pre-test Mode	Power
Mode A	Power from Adapter 1
Mode B	Power from Adapter 2
Mode C	Power from (Terminal Block: 56Vdc)
Mode D	Power from (Terminal Block: 48Vdc)
Mode E	Power from (Terminal Block: 12Vdc)

The worst radiated emissions & AC conducted emissions were found in **Mode A**. Therefore only the test data of the modes were recorded in this report

1.4 Product Specification of Equipment Under Test

Standards-related Product Specification	
Tx/Rx Channel Frequency Range	2412 MHz ~ 2462 MHz
Type of Modulation	802.11b : DSSS (DBPSK / DQPSK / CCK) 802.11g/n : OFDM (BPSK / QPSK / 16QAM / 64QAM)

1.5 Modification of EUT

No modifications are made to the EUT during all test items.

1.6 Testing Location

Sporton Lab is accredited to ISO 17025 by Taiwan Accreditation Foundation (TAF code : 1190) and the FCC designation No. TW1098 under the FCC 2.948(e) by Mutual Recognition Agreement (MRA) in FCC Test.

Test Site	SPORTON INTERNATIONAL INC.	
Test Site Location	No. 52, Hwa Ya 1 st Rd., Hwa Ya Technology Park, Kwei-Shan District, Tao Yuan City, Taiwan, R.O.C. TEL: +886-3-327-3456 FAX: +886-3-328-4978	
Test Site No.	Sporton Site No.	
	CO01-HY	03CH15-HY

Note: The test site complies with ANSI C63.4 2014 requirement.

1.7 Applicable Standards

According to the specifications of the manufacturer, the EUT must comply with the requirements of the following standards:

- FCC Part 15 Subpart C §15.247
- FCC KDB Publication No. 558074 D01 DTS Meas. Guidance v03r05
- ANSI C63.10-2013

Remark:

1. All test items were verified and recorded according to the standards and without any deviation during the test.
2. This EUT has also been tested and complied with the requirements of FCC Part 15, Subpart B, recorded in a separate test report.



2 Test Configuration of Equipment Under Test

The EUT has been associated with peripherals and configuration operated in a manner tended to maximize its emission characteristics in a typical application. Frequency range investigated: conducted emission (150 kHz to 30 MHz) and radiated emission (9 kHz to the 10th harmonic of the highest fundamental frequency or to 40 GHz, whichever is lower).

2.1 Carrier Frequency and Channel

Frequency Band	Channel	Freq. (MHz)	Channel	Freq. (MHz)
2400-2483.5 MHz	1	2412	7	2442
	2	2417	8	2447
	3	2422	9	2452
	4	2427	10	2457
	5	2432	11	2462
	6	2437	-	-



2.2 Test Mode

Final test mode of conducted test items and radiated spurious emissions are considering the modulation and worse data rates as below table.

Modulation	Data Rate
802.11b	1 Mbps
802.11g	6 Mbps
802.11n HT40	MCS0

Test Cases	
AC Conducted Emission	Mode 1 : 11b_20M_CH11 + Adapter

2.3 Connection Diagram of Test System

<WLAN Tx Mode>

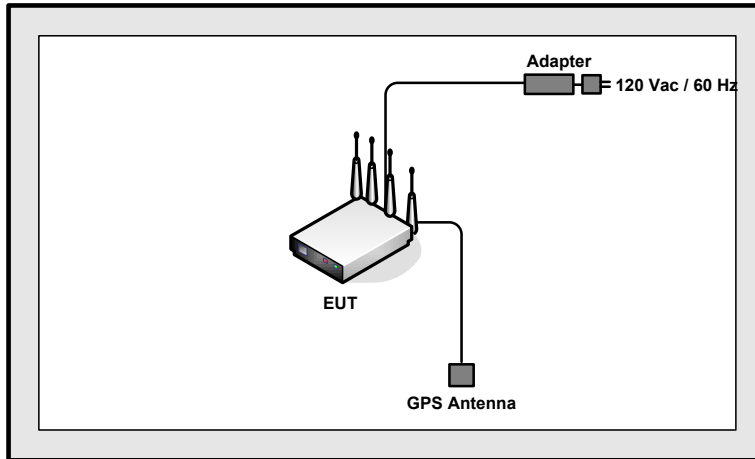

<AC Conducted Emission Mode>

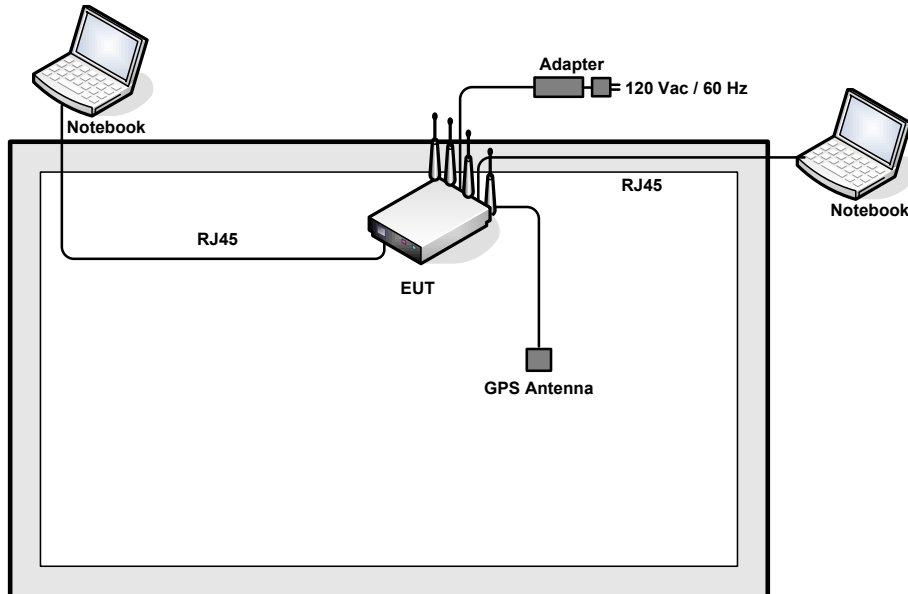



2.4 Support Unit used in test configuration and system

Item	Equipment	Trade Name	Model Name	FCC ID	Data Cable	Power Cord
1.	DC Power supply	Topward	6303D	N/A	N/A	N/A
2.	GPS Antenna	N/A	N/A	N/A	N/A	N/A

2.5 EUT Operation Test Setup

For WLAN RF test items, an engineering test program was provided and enabled to make EUT continuous transmit/receive.



3 Test Result

3.1 Radiated Band Edges and Spurious Emission Measurement

3.1.1 Limit of Radiated band edge and Spurious Emission Measurement

In any 100 kHz bandwidth outside the intentional radiator frequency band, all harmonics/spurious must be at least 20 dB below the highest emission level within the authorized band. If the output power of this device was measured by spectrum analyzer, the attenuation under this paragraph shall be 30 dB instead of 20 dB. In addition, radiated emissions which fall in the restricted bands must also comply with the limits as below.

Frequency (MHz)	Field Strength (microvolts/meter)	Measurement Distance (meters)
0.009 – 0.490	2400/F(kHz)	300
0.490 – 1.705	24000/F(kHz)	30
1.705 – 30.0	30	30
30 – 88	100	3
88 – 216	150	3
216 - 960	200	3
Above 960	500	3

3.1.2 Measuring Instruments

The measuring equipment is listed in the section 4 of this test report.



3.1.3 Test Procedures

1. The testing follows FCC KDB Publication No. 558074 D01 DTS Meas. Guidance v03r05.
2. The EUT was arranged to its worst case and then tune the antenna tower (from 1 m to 4 m) and turntable (from 0 degree to 360 degrees) to find the maximum reading. A pre-amp and a high pass filter are used for the test in order to get better signal level.
3. The EUT was placed on a turntable with 0.8 meter for frequency below 1GHz and 1.5 meter for frequency above 1GHz respectively above ground.
4. The EUT was set 3 meters from the interference receiving antenna, which was mounted on the top of a variable height antenna tower.
5. Corrected Reading: Antenna Factor + Cable Loss + Read Level - Preamp Factor = Level
6. For measurement below 1GHz, If the emission level of the EUT measured by the peak detector is 3 dB lower than the applicable limit, the peak emission level will be reported. Otherwise, the emission measurement will be repeated using the quasi-peak detector and reported.
7. Use the following spectrum analyzer settings:
 - (1) Span shall wide enough to fully capture the emission being measured;
 - (2) Set RBW=100 kHz for $f < 1$ GHz; $VBW \geq RBW$; Sweep = auto; Detector function = peak; Trace = max hold;
 - (3) Set RBW = 1 MHz, $VBW = 3$ MHz for $f \geq 1$ GHz for peak measurement.
For average measurement:
 - $VBW = 10$ Hz, when duty cycle is no less than 98 percent.
 - $VBW \geq 1/T$, when duty cycle is less than 98 percent where T is the minimum transmission duration over which the transmitter is on and is transmitting at its maximum power control level for the tested mode of operation.

3.1.4 Test Setup

For radiated emissions below 30MHz

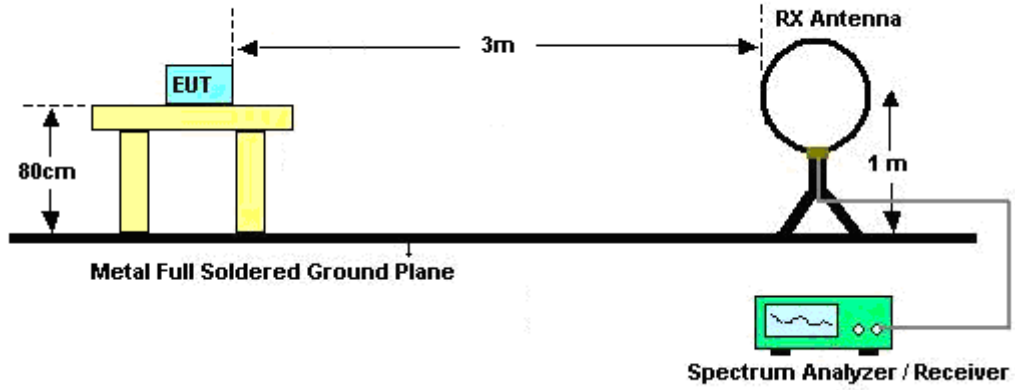

For radiated emissions from 30MHz to 1GHz

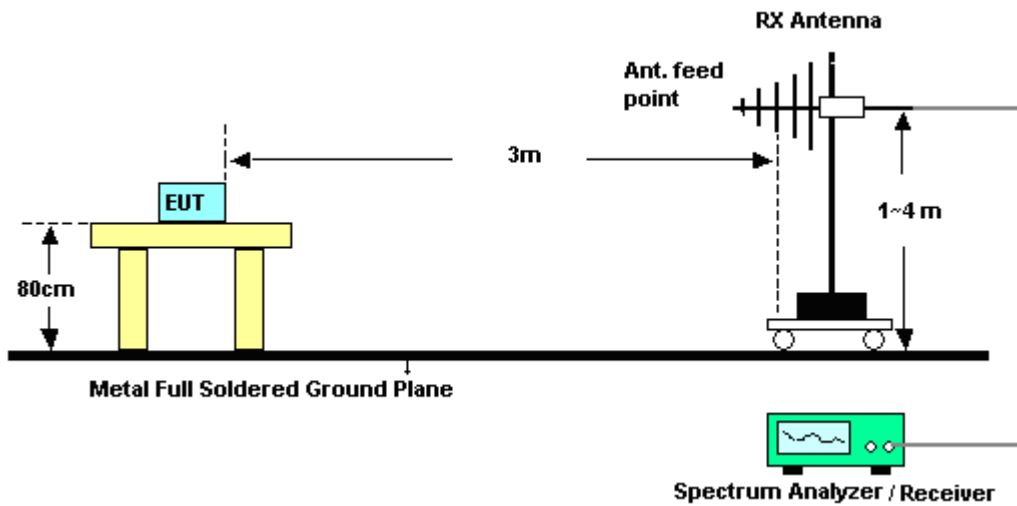

For radiated emissions above 1GHz

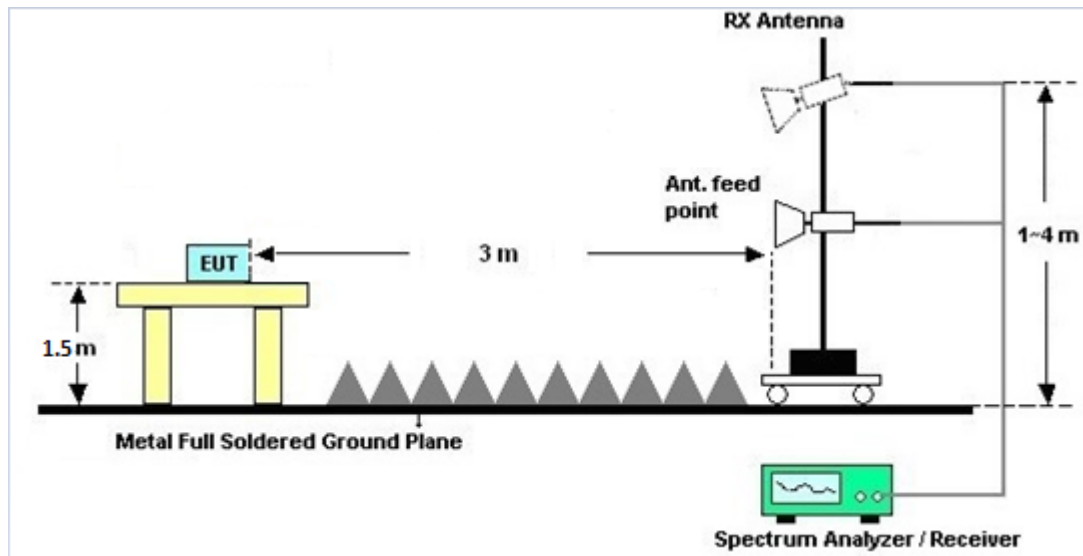

3.1.5 Test Results of Radiated Spurious Emissions (9kHz ~ 30MHz)

The low frequency, which started from 9 kHz to 30MHz, was pre-scanned and the result which was 20dB lower than the limit line was not reported.

3.1.6 Test Result of Radiated Spurious at Band Edges

Please refer to Appendix A.

3.1.7 Duty Cycle

Please refer to Original Report.

3.1.8 Test Result of Radiated Spurious Emission (30MHz ~ 10th Harmonic)

Please refer to Appendix A.



3.2 AC Conducted Emission Measurement

3.2.1 Limit of AC Conducted Emission

For equipment that is designed to be connected to the public utility (AC) power line, the radio frequency voltage that is conducted back onto the AC power line on any frequency or frequencies within the band 150 kHz to 30 MHz shall not exceed the limits in the following table.

Frequency of Emission (MHz)	Conducted Limit (dBµV)	
	Quasi-Peak	Average
0.15-0.5	66 to 56*	56 to 46*
0.5-5	56	46
5-30	60	50

*Decreases with the logarithm of the frequency.

3.2.2 Measuring Instruments

The measuring equipment is listed in the section 4 of this test report.

3.2.3 Test Procedures

1. The EUT was placed 0.4 meter from the conducting wall of the shielding room, and it was kept at least 80 centimeters from any other grounded conducting surface.
2. Connect EUT to the power mains through a line impedance stabilization network (LISN).
3. All the support units are connecting to the other LISN.
4. The LISN provides 50 ohm coupling impedance for the measuring instrument.
5. The FCC states that a 50 ohm, 50 microhenry LISN should be used.
6. Both sides of AC line were checked for maximum conducted interference.
7. The frequency range from 150 kHz to 30 MHz was searched.
8. Set the test-receiver system to Peak Detect Function and specified bandwidth (IF bandwidth = 9kHz) with Maximum Hold Mode.

3.2.4 Test Setup

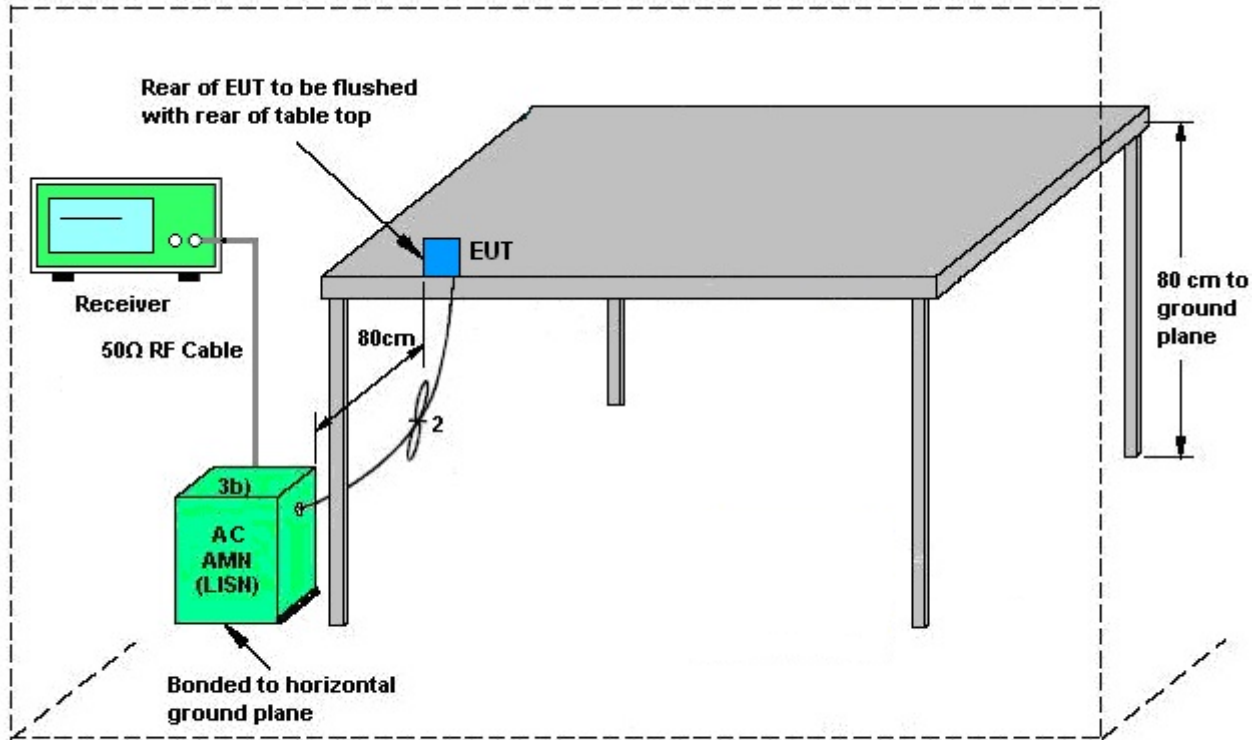

AMN = Artificial mains network (LISH)
 AE = Associated equipment
 EUT = Equipment under test
 ISN = Impedance stabilization network



3.2.5 Test Result of AC Conducted Emission

Test Mode :	Mode 1	Temperature :	22~24°C
Test Engineer :	Will Chen	Relative Humidity :	54~56%
Test Voltage :	120Vac / 60Hz	Phase :	Line
Function Type :	11b_20M_CH11 + Adapter		

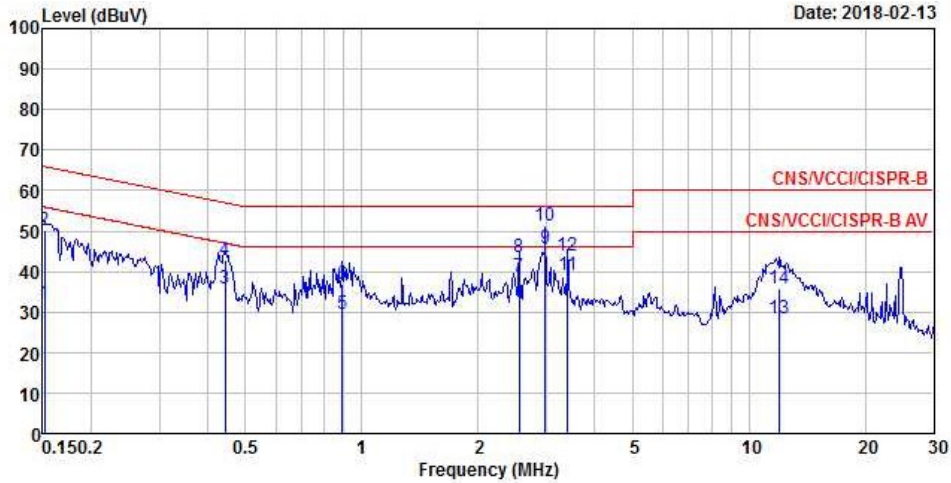

Site : CO01-HY
 Condition: CNS/VCCI/CISPR-B LISN216-101274-10604 LINE
 Power : 120Vac/60Hz
 EUT : 820633
 Memo : Mode 1

	Freq	Level	Over Limit	Limit Line	Read Level	LISN Factor	Cable Loss	Remark
	MHz	dBuV	dB	dBuV	dBuV	dB	dB	
1	0.15	32.23	-23.68	55.91	22.58	9.63	0.02	Average
2	0.15	50.00	-15.91	65.91	40.35	9.63	0.02	QP
3	0.44	35.70	-11.28	46.98	26.05	9.63	0.02	Average
4	0.44	42.75	-14.23	56.98	33.10	9.63	0.02	QP
5	0.89	29.53	-16.47	46.00	19.88	9.63	0.02	Average
6	0.89	36.73	-19.27	56.00	27.08	9.63	0.02	QP
7	2.55	38.57	-7.43	46.00	28.86	9.65	0.06	Average
8	2.55	43.71	-12.29	56.00	34.00	9.65	0.06	QP
9 MAX	2.98	45.58	-0.42	46.00	35.85	9.66	0.07	Average
10	2.98	51.14	-4.86	56.00	41.41	9.66	0.07	QP
11	3.41	38.96	-7.04	46.00	29.23	9.66	0.07	Average
12	3.41	43.95	-12.05	56.00	34.22	9.66	0.07	QP
13	12.00	28.25	-21.75	50.00	18.39	9.68	0.18	Average
14	12.00	35.75	-24.25	60.00	25.89	9.68	0.18	QP



Test Mode :	Mode 1	Temperature :	22~24°C
Test Engineer :	Will Chen	Relative Humidity :	54~56%
Test Voltage :	120Vac / 60Hz	Phase :	Neutral
Function Type :	11b_20M_CH11 + Adapter		

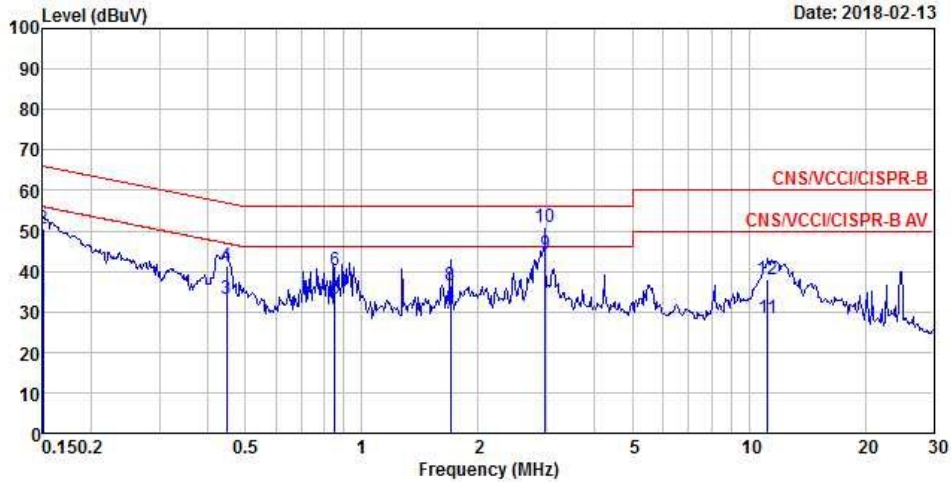

Site : CO01-HY
 Condition: CNS/VCCI/CISPR-B LISN216-101274-10604 NEUTRAL
 Power : 120Vac/60Hz
 EUT : 820633
 Memo : Mode 1

	Freq	Level	Over	Limit	Read	LISN	Cable	Remark
	MHz	dBuV	dB	dBuV	dBuV	dB	dB	
1	0.15	32.84	-23.16	56.00	23.17	9.65	0.02	Average
2	0.15	50.66	-15.34	66.00	40.99	9.65	0.02	QP
3	0.45	33.29	-13.64	46.93	23.63	9.64	0.02	Average
4	0.45	41.38	-15.55	56.93	31.72	9.64	0.02	QP
5	0.85	33.38	-12.62	46.00	23.72	9.64	0.02	Average
6	0.85	40.27	-15.73	56.00	30.61	9.64	0.02	QP
7	1.70	29.46	-16.54	46.00	19.76	9.66	0.04	Average
8	1.70	36.67	-19.33	56.00	26.97	9.66	0.04	QP
9 MAX	2.98	44.13	-1.87	46.00	34.39	9.67	0.07	Average
10	2.98	50.94	-5.06	56.00	41.20	9.67	0.07	QP
11	11.20	28.52	-21.48	50.00	18.61	9.74	0.17	Average
12	11.20	38.19	-21.81	60.00	28.28	9.74	0.17	QP



4 List of Measuring Equipment

Instrument	Manufacturer	Model No.	Serial No.	Calibration Date	Test Date	Due Date	Remark
EMC Receiver	R&S	ESR3	102052	Apr. 05, 2017	Feb. 13, 2018	Apr. 04, 2018	Conduction (CO01-HY)
LISN	R&S	ENV 216	101274	Apr. 20, 2017	Feb. 13, 2018	Apr. 19, 2018	Conduction (CO01-HY)
RF Cable-CON	HUBER+SUHNER	RG213/U	07611832010001	Mar. 06, 2017	Feb. 13, 2018	Mar. 05, 2018	Conduction (CO01-HY)
Impuls Begrenzer Pulse Limiter	SCHWARZBECK	VTSD 9561F	9495	Oct. 12, 2017	Feb. 13, 2018	Oct. 11, 2018	Conduction (CO01-HY)
Software	Audix	e3	6.12160809	NCR	Feb. 13, 2018	NCR	Conduction (CO01-HY)
Bilog Antenna	TESEQ	CBL6111D&00800N1D01N-06	41912&05	Jan. 10, 2018	Feb. 14, 2018	Jan. 09, 2019	Radiation (03CH15-HY)
Horn Antenna	SCHWARZBECK	BBHA 9120D	9120D-1620	Oct. 03, 2017	Feb. 14, 2018	Oct. 02, 2018	Radiation (03CH15-HY)
Loop Antenna	Rohde & Schwarz	HFH2-Z2	100315	Nov. 10, 2017	Feb. 14, 2018	Nov. 09, 2019	Radiation (03CH15-HY)
SHF-EHF Horn Antenna	SCHWARZBECK	BBHA 9170	BBHA9170576	Apr. 26, 2018	Feb. 14, 2018	Apr. 26, 2018	Radiation (03CH15-HY)
Preamplifier	Keysight	83017A	MY53270195	Aug. 20, 2018	Feb. 14, 2018	Aug. 20, 2018	Radiation (03CH15-HY)
Amplifier	SONOMA	310N	363440	Dec. 25, 2018	Feb. 14, 2018	Dec. 25, 2018	Radiation (03CH15-HY)
Amplifier	MITEQ	TTA1840-35-HG	1871923	Jul. 17, 2018	Feb. 14, 2018	Jul. 17, 2018	Radiation (03CH15-HY)
Antenna Mast	ChainTek	MBS-520-1	N/A	N/A	Feb. 14, 2018	N/A	Radiation (03CH15-HY)
Turn Table	ChainTek	T-200-S-1	N/A	N/A	Feb. 14, 2018	N/A	Radiation (03CH15-HY)
Spectrum Analyzer	Rohde & Schwarz	FSQ	200578	Mar. 21, 2018	Feb. 14, 2018	Mar. 21, 2018	Radiation (03CH15-HY)
Spectrum Analyzer	Rohde & Schwarz	FSV	101183	Jan. 03, 2019	Feb. 14, 2018	Jan. 03, 2019	Radiation (03CH15-HY)
EMI Test Receiver	Rohde & Schwarz	ESR3	102317	Jul. 19, 2018	Feb. 14, 2018	Jul. 19, 2018	Radiation (03CH15-HY)
RF signal cable	HUBER+SUHNER	SUCOFLEX 104	MY11681/4PE	Mar. 15, 2018	Feb. 14, 2018	Mar. 15, 2018	Radiation (03CH15-HY)
RF signal cable	HUBER+SUHNER	SUCOFLEX 104	MY36980/4	Mar. 16, 2018	Feb. 14, 2018	Mar. 16, 2018	Radiation (03CH15-HY)
Software	Audix	E3 6.2009-8-24	N/A	N/A	Feb. 14, 2018	N/A	Radiation (03CH15-HY)

NCR: No Calibration Required



5 Uncertainty of Evaluation

Uncertainty of Conducted Emission Measurement (150kHz ~ 30MHz)

Measuring Uncertainty for a Level of Confidence of 95% ($U = 2Uc(y)$)	2.3dB
---	-------

Uncertainty of Radiated Emission Measurement (30 MHz ~ 1000 MHz)

Measuring Uncertainty for a Level of Confidence of 95% ($U = 2Uc(y)$)	4.6dB
---	-------

Uncertainty of Radiated Emission Measurement (1GHz ~ 18GHz)

Measuring Uncertainty for a Level of Confidence of 95% ($U = 2Uc(y)$)	4.5dB
---	-------

Uncertainty of Radiated Emission Measurement (18GHz ~ 40GHz)

Measuring Uncertainty for a Level of Confidence of 95% ($U = 2Uc(y)$)	4.7dB
---	-------



Appendix A. Radiated Spurious Emission

2.4GHz 2400~2483.5MHz

WIFI 802.11b (Spurious Emission @ 3m)

WIFI	Note	Frequency	Level	Over Limit	Limit Line	Read Level	Antenna Factor	Cable Loss	Preamp Factor	Ant Pos	Table Pos	Peak Avg.	Pol.
		(MHz)	(dBμV/m)	(dB)	(dBμV/m)	(dBμV)	(dB/m)	(dB)	(dB)	(cm)	(deg)	(P/A)	(H/V)
802.11b 20M CH 11 2462MHz	*	2462	95.28	-	-	94.6	27.5	4.01	30.83	141	265	A	H
	*	2462	99.91	-	-	99.23	27.5	4.01	30.83	141	265	P	H
		2483.52	40.42	-13.58	54	39.65	27.55	4.04	30.82	141	265	A	H
		2485.4	53.12	-20.88	74	52.35	27.55	4.04	30.82	141	265	P	H
		4924	52.07	-1.93	54	44.87	31.56	5.74	30.1	100	260	A	H
		4924	56.58	-17.42	74	49.38	31.56	5.74	30.1	100	260	P	H
	*	2462	83.47	-	-	82.79	27.5	4.01	30.83	327	345	A	V
	*	2462	87.91	-	-	87.23	27.5	4.01	30.83	327	345	P	V
		2487.32	52.38	-21.62	74	51.61	27.55	4.04	30.82	327	345	P	V
		2488.04	39.73	-14.27	54	38.91	27.6	4.04	30.82	327	345	A	V
		4924	41.53	-12.47	54	34.33	31.56	5.74	30.1	392	142	A	V
		4924	45.97	-28.03	74	38.77	31.56	5.74	30.1	392	142	P	V
Remark	1. No other spurious found. 2. All results are PASS against limit line.												



2.4GHz 2400~2483.5MHz

WIFI 802.11g (Spurious Emission @ 3m)

WIFI	Note	Frequency (MHz)	Level (dBμV/m)	Over Limit (dB)	Limit Line (dBμV/m)	Read Level (dBμV)	Antenna Factor (dB/m)	Cable Loss (dB)	Preamp Factor (dB)	Ant Pos (cm)	Table Pos (deg)	Peak Avg. (P/A)	Pol. (H/V)
802.11g 20M CH 11 2462MHz	*	2462	101.28	-	-	100.6	27.5	4.01	30.83	141	265	A	H
	*	2462	110.89	-	-	110.21	27.5	4.01	30.83	141	265	P	H
		2483.64	46.33	-7.67	54	45.56	27.55	4.04	30.82	141	265	A	H
		2485.04	64.93	-9.07	74	64.16	27.55	4.04	30.82	141	265	P	H
		4924	50.28	-3.72	54	43.08	31.56	5.74	30.1	100	265	A	H
		4924	63.64	-10.36	74	56.44	31.56	5.74	30.1	100	265	P	H
		7386	42.39	-11.61	54	30.3	36.27	7.07	31.25	100	273	A	H
		7386	55.78	-18.22	74	43.69	36.27	7.07	31.25	100	273	P	H
	*	2462	89.27	-	-	88.59	27.5	4.01	30.83	327	345	A	V
	*	2462	98.76	-	-	98.08	27.5	4.01	30.83	327	345	P	V
		2487.16	40.92	-13.08	54	40.15	27.55	4.04	30.82	327	345	A	V
		2489.6	52.65	-21.35	74	51.83	27.6	4.04	30.82	327	345	P	V
		4924	40.43	-13.57	54	33.23	31.56	5.74	30.1	392	142	A	V
		4924	53.99	-20.01	74	46.79	31.56	5.74	30.1	392	142	P	V
Remark	1. No other spurious found. 2. All results are PASS against limit line.												



2.4GHz 2400~2483.5MHz

WIFI 802.11n (Spurious Emission @ 3m)

WIFI	Note	Frequency (MHz)	Level (dBμV/m)	Over Limit (dB)	Limit Line (dBμV/m)	Read Level (dBμV)	Antenna Factor (dB/m)	Cable Loss (dB)	Preamp Factor (dB)	Ant Pos (cm)	Table Pos (deg)	Peak Avg. (P/A)	Pol. (H/V)
802.11n 40M CH 03 2422MHz		2387.385	54.85	-19.15	74	54.44	27.31	3.96	30.86	169	265	P	H
		2389.905	43.26	-10.74	54	42.84	27.31	3.96	30.85	169	265	A	H
	*	2422	94.43	-	-	93.87	27.41	3.99	30.84	169	265	A	H
	*	2422	104.15	-	-	103.59	27.41	3.99	30.84	169	265	P	H
		4844	39.36	-14.64	54	32.39	31.39	5.7	30.12	110	260	A	H
		4844	52.87	-21.13	74	45.9	31.39	5.7	30.12	110	260	P	H
		2380.875	40.88	-13.12	54	40.52	27.26	3.96	30.86	332	304	A	V
		2382.24	51.52	-22.48	74	51.16	27.26	3.96	30.86	332	304	P	V
	*	2422	81.59	-	-	81.03	27.41	3.99	30.84	332	304	A	V
	*	2422	91.35	-	-	90.79	27.41	3.99	30.84	332	304	P	V
		4844	33.68	-20.32	54	26.71	31.39	5.7	30.12	390	142	A	V
		4844	46.97	-27.03	74	40	31.39	5.7	30.12	390	142	P	V
Remark	1. No other spurious found. 2. All results are PASS against limit line.												



Emission below 1GHz

2.4GHz WIFI (LF)

WIFI	Note	Frequency	Level	Over	Limit	Read	Antenna	Cable	Preamp	Ant	Table	Peak	Pol.
		(MHz)	(dBμV/m)	(dB)	(dBμV/m)	(dBμV)	(dB/m)	(dB)	(dB)	(cm)	(deg)	Quasi- Peak (P/QP)	(H/V)
2.4GHz WIFI LF		164.46	26.84	-16.66	43.5	42.23	16.16	1	32.55	-	-	P	H
		214.95	27.47	-16.03	43.5	43.6	15.25	1.16	32.54	-	-	P	H
		280.02	40.46	-5.54	46	52.78	18.88	1.33	32.53	-	-	P	H
		440	42.38	-3.62	46	50.31	22.94	1.67	32.54	-	-	P	H
		699.7	41.25	-4.75	46	44.94	26.7	2.1	32.49	-	-	P	H
		920.2	43.62	-2.38	46	43.01	29.71	2.43	31.53	153	104	QP	H
		38.91	37.5	-2.5	40	49.61	20.07	0.46	32.64	100	283	QP	V
		60.24	35.05	-4.95	40	55.03	11.96	0.67	32.61	-	-	P	V
		280.02	33.63	-12.37	46	45.95	18.88	1.33	32.53	-	-	P	V
		440	42.39	-3.61	46	50.32	22.94	1.67	32.54	-	-	P	V
		599.6	36.19	-9.81	46	40.97	25.85	1.94	32.57	-	-	P	V
		920.2	39.27	-6.73	46	38.66	29.71	2.43	31.53	-	-	P	V
Remark	1. No other spurious found. 2. All results are PASS against limit line.												



Note symbol

*	Fundamental Frequency which can be ignored. However, the level of any unwanted emissions shall not exceed the level of the fundamental frequency.
!	Test result is over limit line.
P/A	Peak or Average
P/QP	Peak or Quasi-Peak
H/V	Horizontal or Vertical



A calculation example for radiated spurious emission is shown as below:

WIFI	Note	Frequency	Level	Over	Limit	Read	Antenna	Cable	Preamp	Ant	Table	Peak	Pol.
Ant.				Limit	Line	Level	Factor	Loss	Factor	Pos	Pos	Avg.	
1+2		(MHz)	(dBμV/m)	(dB)	(dBμV/m)	(dBμV)	(dB/m)	(dB)	(dB)	(cm)	(deg)	(P/A)	(H/V)
802.11b		2390	55.45	-18.55	74	54.51	32.22	4.58	35.86	103	308	P	H
CH 01													
2412MHz		2390	43.54	-10.46	54	42.6	32.22	4.58	35.86	103	308	A	H

- Level(dBμV/m) =
Antenna Factor(dB/m) + Cable Loss(dB) + Read Level(dBμV) - Preamp Factor(dB)
- Over Limit(dB) = Level(dBμV/m) – Limit Line(dBμV/m)

For Peak Limit @ 2390MHz:

- Level(dBμV/m)
= Antenna Factor(dB/m) + Cable Loss(dB) + Read Level(dBμV) - Preamp Factor(dB)
= 32.22(dB/m) + 4.58(dB) + 54.51(dBμV) – 35.86 (dB)
= 55.45 (dBμV/m)
- Over Limit(dB)
= Level(dBμV/m) – Limit Line(dBμV/m)
= 55.45(dBμV/m) – 74(dBμV/m)
= -18.55(dB)

For Average Limit @ 2390MHz:

- Level(dBμV/m)
= Antenna Factor(dB/m) + Cable Loss(dB) + Read Level(dBμV) - Preamp Factor(dB)
= 32.22(dB/m) + 4.58(dB) + 42.6(dBμV) – 35.86 (dB)
= 43.54 (dBμV/m)
- Over Limit(dB)
= Level(dBμV/m) – Limit Line(dBμV/m)
= 43.54(dBμV/m) – 54(dBμV/m)
= -10.46(dB)

Both peak and average measured complies with the limit line, so test result is “PASS”.