

# FCC REPORT

## Certification

**Applicant Name:**  
GS Instech Co., Ltd.**Date of Issue:**  
November 21, 2018**Address:**  
70, Gilpa-ro 71beon-gil, Nam-gu, Inchen, Korea**Location of test lab:**  
HCT CO., LTD.,  
74, Seoicheon-ro 578beon-gil, Majang-myeon,  
Icheon-si, Gyeonggi-do, 17383, Rep. of KOREA**Report No.:** HCT-RF-1811-FC015**FCC ID:** U88-B10K**APPLICANT:** GS Instech Co., Ltd.**Model:** B-10K**EUT Type:** In-building RF repeater**Frequency Range:**

Band Name	Downlink (MHz)	Uplink (MHz)
Lower 700 MHz	734 ~ 746	704 ~ 716
Upper 700 MHz	746 ~ 756	777 ~ 787
Cellular	869 ~ 894	824 ~ 849
AWS-1	2 110 ~ 2 155	1 710 ~ 1 755
Broadband PCS	1 930 ~ 1 995	1 850 ~ 1 915

**Output Power:** 5 dBm (DL) / 20 dBm (UL)**Date of Test:** October 11, 2018 ~ November 10, 2018**FCC Rule Parts:** CFR 47 Part 2, Part 22, Part 24, Part 27

The measurements shown in this report were made in accordance with the procedures indicated, and the emissions from this equipment were found to be within the limits applicable. I assume full responsibility for the accuracy and completeness of these measurements, and for the qualifications of all persons taking them. It is further stated that upon the basis of the measurements made, the equipment tested is capable of operation in accordance with the requirements of the FCC Rules under normal use and maintenance.



Report prepared by : Kwang il Yoon  
Engineer of telecommunication testing center



Approved by : Jong Seok Lee  
Manager of telecommunication testing center

This report only responds to the tested sample and may not be reproduced, except in full, without written approval of the HCT Co., Ltd.

## Version

TEST REPORT NO.	DATE	DESCRIPTION
HCT-RF-1811-FC015	November 21, 2018	- First Approval Report

# Table of Contents

1. GENERAL INFORMATION.....	4
1.1. APPLICANT INFORMATION.....	4
1.2. PRODUCT INFORMATION .....	4
1.3. TEST INFORMATION .....	4
2. FACILITIES AND ACCREDITATIONS .....	5
2.1. FACILITIES .....	5
2.2. EQUIPMENT .....	5
3. TEST SPECIFICATIONS.....	6
3.1. STANDARDS .....	6
3.2. ADDITIONAL DESCRIPTIONS ABOUT TEST .....	7
3.3. MEASUREMENT UNCERTAINTY.....	9
3.4. STANDARDS ENVIRONMENTAL TEST CONDITIONS.....	9
3.5. TEST DIAGRAMS.....	10
4. TEST EQUIPMENTS.....	11
5. TEST RESULT .....	12
5.1. AGC THRESHOLD .....	12
5.2. OUT-OF-BAND REJECTION.....	14
5.3. INPUT-VERSUS-OUTPUT SIGNAL COMPARISON .....	20
5.4. MEAN OUTPUT POWER AND AMPLIFIER/BOOSTER GAIN .....	47
5.5. OUT-OF-BAND/OUT-OF-BLOCK EMISSIONS AND SPURIOUS EMISSIONS.....	60
5.6. RADIATED SPURIOUS EMISSIONS .....	281
6. Annex A_EUT AND TEST SETUP PHOTO .....	283

## 1. GENERAL INFORMATION

### 1.1. APPLICANT INFORMATION

Company Name	GS Instech Co., Ltd.
Company Address	70, Gilpa-ro 71beon-gil, Nam-gu, Inchen, Korea

### 1.2. PRODUCT INFORMATION

EUT Type	In-building RF repeater		
Power Supply	110 ~ 220 V AC, AC/DC Adaptor Output : 7.5 Vdc X 5.4 Amps		
Frequency Range	Band Name	Downlink (MHz)	Uplink (MHz)
	Lower 700 MHz	734 ~ 746	704 ~ 716
	Upper 700 MHz	746 ~ 756	777 ~ 787
	Cellular	869 ~ 894	824 ~ 849
	AWS-1	2 110 ~ 2 155	1 710 ~ 1 755
	Broadband PCS	1 930 ~ 1 995	1 850 ~ 1 915
Tx Output Power	5 dBm (DL) / 20 dBm (UL)		
Antenna Specification	Service (DL) Panel Antenna : 7 dBi (698 ~ 960 MHz) / 10 dBi (1 710 ~ 2 700 MHz) Donor (UL) Yagi Antenna : 9 dBi (698 ~ 960 MHz) / 11 dBi (1 710 ~ 2 700 MHz)		

### 1.3. TEST INFORMATION

FCC Rule Parts	CFR 47 Part 2, Part 22, Part 24, Part 27
Measurement Standards	KDB 935210 D05 v01r02, ANSI C63.26-2015
Test Location	HCT CO., LTD. 74, Seoicheon-ro 578beon-gil, Majang-myeon, Icheon-si, Gyeonggi-do, 17383, Rep. of KOREA

## **2. FACILITIES AND ACCREDITATIONS**

### **2.1. FACILITIES**

The SAC (Semi-Anechoic Chamber) and conducted measurement facility used to collect the radiated data are located at the 74, Seoicheon-ro 578beon-gil, Majang-myeon, Icheon-si, Gyeonggi-do, 17383, Rep. of KOREA.

The site is constructed in conformance with the requirements of ANSI C63.4 (Version: 2014) and CISPR Publication 22.

Detailed description of test facility was submitted to the Commission and accepted dated April 02, 2018 (Registration Number: KR0032).

### **2.2. EQUIPMENT**

Radiated emissions are measured with one or more of the following types of linearly polarized antennas: tuned dipole, bi-conical, log periodic, bi-log, and/or ridged waveguide, horn. Spectrum analyzers with pre-selectors and quasi-peak detectors are used to perform radiated measurements.

Calibrated wideband preamplifiers, coaxial cables, and coaxial attenuators are also used for making measurements.

All receiving equipment conforms to CISPR Publication 16-1, "Radio Interference Measuring Apparatus and Measurement Methods."

### 3. TEST SPECIFICATIONS

#### 3.1. STANDARDS

The following tests were conducted on a sample of the equipment for the purpose of demonstrating compliance with FCC Part 2, Part 22, Part 24 and Part 27.

Description	Reference	Results
AGC threshold	KDB 935210 D05 v01r02 3.2	Compliant
Out-of-band rejection	KDB 935210 D05 v01r02 3.3	Compliant
Input-versus-output signal comparison	§2.1049	Compliant
Mean output power and amplifier/booster gain	§2.1046, §22.913, §24.232, §27.50(b),(c),(d)	Compliant
Out-of-band/out-of-block and spurious emissions	§2.1051, §22.917, §24.238, §27.53(c),(f),(g),(h)	Compliant
Spurious emissions radiated	§2.1053	Compliant

### 3.2. ADDITIONAL DESCRIPTIONS ABOUT TEST

Except for the following cases, EUT was tested under normal operating conditions.

: Out-of-band rejection test requires maximum gain condition without AGC

The test was generally based on the method of KDB 935210 D05 v01r02 and only followed ANSI C63.26-2015 if there was no test method in KDB standard.

EUT was tested with following modulated signals provide by applicant.

Band Name	Tested signals
Lower 700 MHz	LTE 10 MHz
Upper 700 MHz	LTE 10 MHz
Cellular	CDMA, 1xEV-DO, LTE 5 MHz
Broadband PCS	CDMA, 1xEV-DO, LTE 20 MHz
AWS-1	LTE 10 MHz

\* We have done CDMA and 1xEVDO modulation test in technology. Test results are only attached worst cases.

The frequency stability measurement has been omitted in accordance with section 3.7 of KDB 935210 D05 v01r02.

: It can be confirmed through input-versus-output signal comparison test that EUT does not alter the input signal.

The tests results included actual loss value for attenuator and cable combination as shown in the table below.

: Input Path

Correction factor table					
Frequency (MHz)	Factor (dB)	Frequency (MHz)	Factor (dB)	Frequency (MHz)	Factor (dB)
600	1.055	1 200	1.564	2 200	2.067
650	1.134	1 300	1.588	2 300	2.099
700	1.167	1 400	1.588	2 400	2.226
750	1.163	1 500	1.744	2 500	2.241
800	1.204	1 600	1.895	2 600	2.295
850	1.188	1 700	1.769	2 700	2.158
900	1.187	1 800	1.775	2 800	2.172
950	1.240	1 900	1.806	2 900	2.377
1 000	1.223	2 000	1.967	3 000	2.655
1 100	1.291	2 100	2.008	-	-

: Output Path

Correction factor table			
Frequency (MHz)	Factor (dB)	Frequency (MHz)	Factor (dB)
2	20.975	9 000	22.740
10	20.391	9 500	22.153
30	20.073	10 000	24.544
50	20.022	10 500	23.789
100	20.007	11 000	23.800
200	20.093	11 500	23.470
300	20.388	12 000	23.312
400	20.448	12 500	23.643
500	20.555	13 000	22.867
600	20.598	13 500	24.509
700	20.668	14 000	24.278
750	20.646	14 500	22.686
800	20.666	15 000	23.690
850	20.661	15 500	23.261
900	20.636	16 000	23.564
1 000	20.655	16 500	24.124
1 500	20.998	17 000	23.494
2 000	21.165	17 500	24.199
2 500	21.384	18 000	23.910
3 000	21.675	19 000	24.397
3 500	21.691	20 000	25.216
4 000	21.830	21 000	26.594
4 500	21.619	22 000	26.103
5 000	21.827	23 000	27.272
5 500	22.056	24 000	27.122
6 000	22.183	25 000	28.000
6 500	22.851	26 000	27.297
7 000	22.214	26 500	29.124
7 500	22.442	-	-
8 000	22.425	-	-
8 500	22.240	-	-



### 3.3. MEASUREMENT UNCERTAINTY

Description	Reference	Results
AGC threshold	-	±0.87 dB
Out-of-band rejection	-	±0.58 MHz
Input-versus-output signal comparison		
Mean output power and amplifier/booster gain	-	±0.87 dB
Out-of-band/out-of-block and spurious emissions	-	±1.08 dB
Spurious emissions radiated	$f \leq 1 \text{ GHz}$	±4.80 dB
	$f > 1 \text{ GHz}$	±6.07 dB

\* Coverage factor  $k = 2$ , Confidence levels of 95 %

### 3.4. STANDARDS ENVIRONMENTAL TEST CONDITIONS

Temperature	+15 °C to +35 °C
Relative humidity	30 % to 60 %
Air pressure	860 mbar to 1 060 mbar

### 3.5. TEST DIAGRAMS

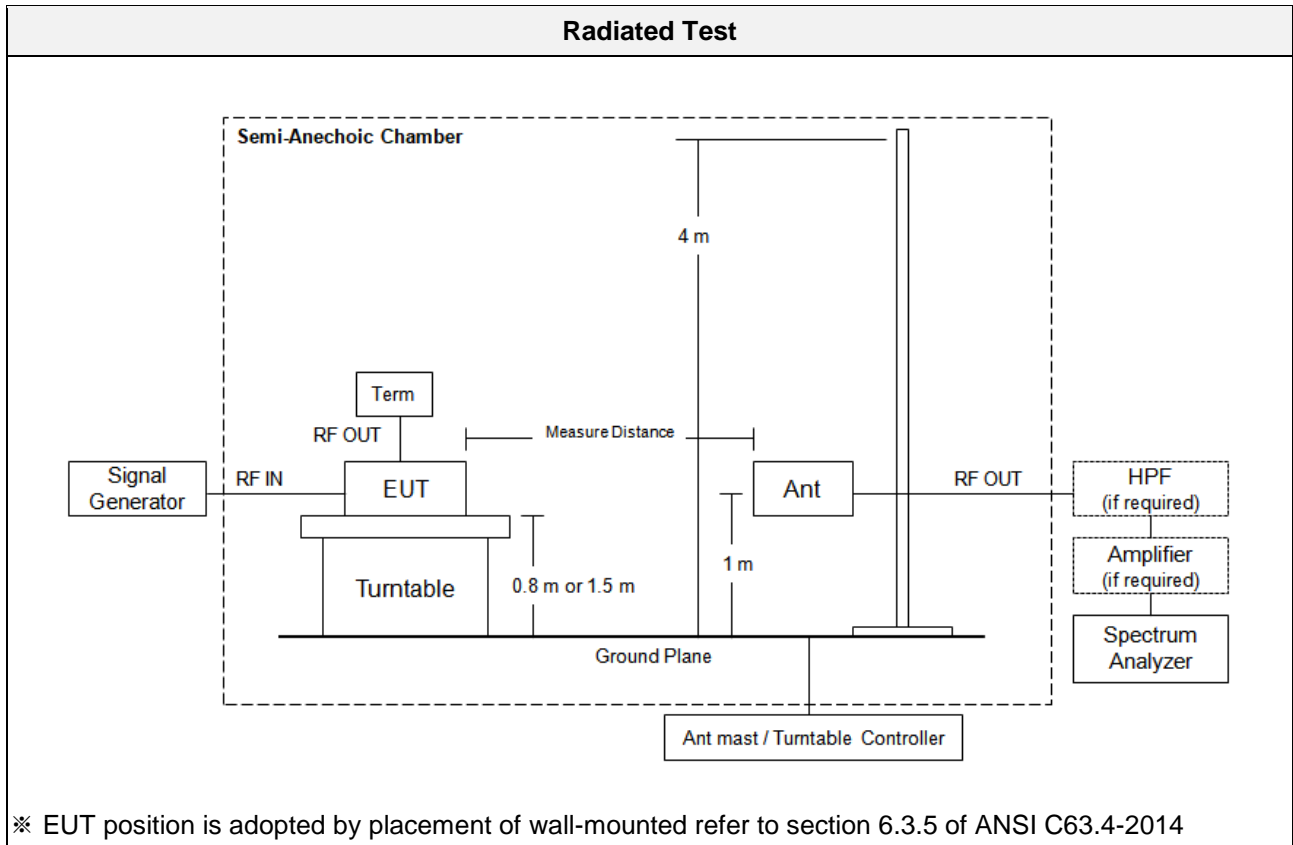
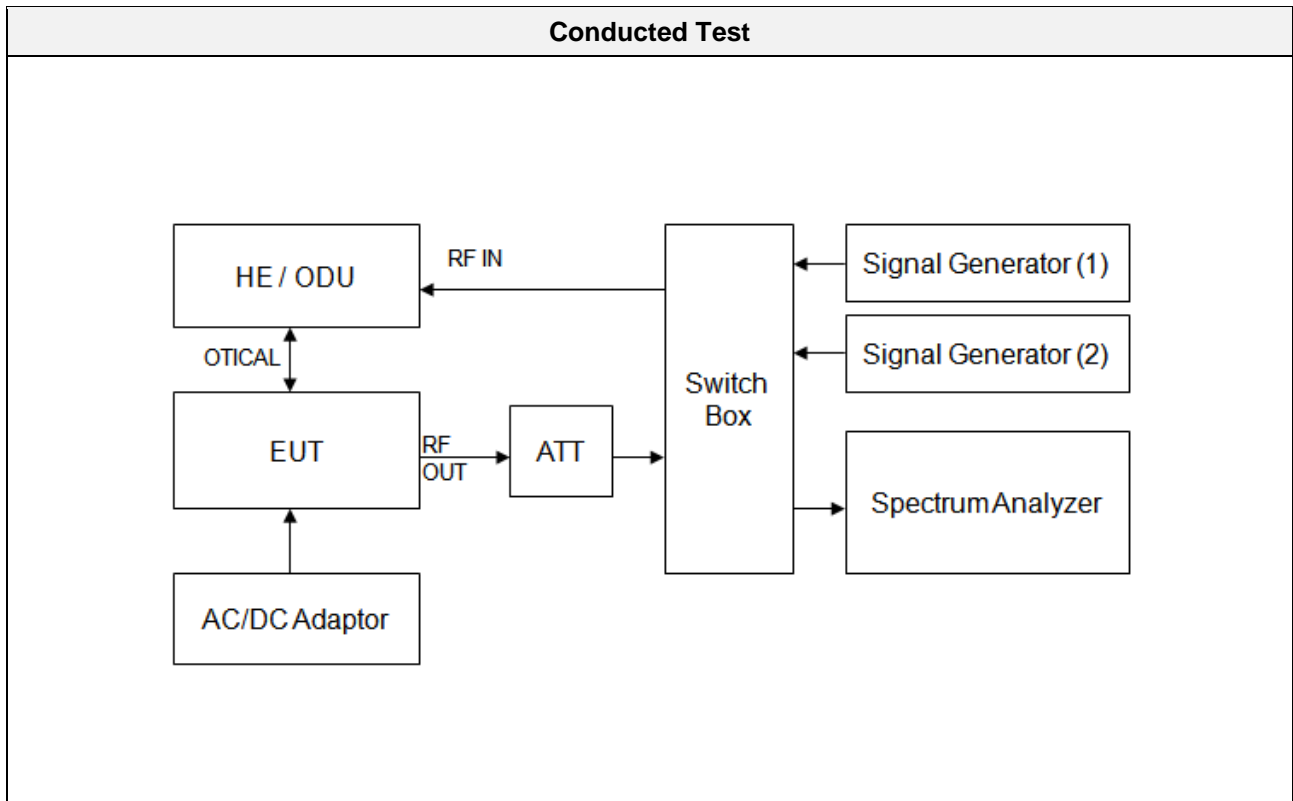

## 4. TEST EQUIPMENTS

Manufacturer	Model / Equipment	Calibration Date	Calibration Interval	Serial No.
Agilent	N9020A / Spectrum Analyzer	09/05/2018	Annual	MY46471250
Agilent	N5182A / Signal Generator	08/09/2018	Annual	MY50140312
Agilent	N5182A / Signal Generator	08/30/2018	Annual	MY46240523
Changwoo	18N-20 dB / Attenuator	09/13/2018	Annual	4
KEITHLEY	S46 / Switch	N/A	N/A	1088024
Deayoung ENT	DFSS60 / AC Power Supply	04/05/2018	Annual	1003030-1
Innco system	CO3000 / Controller(Antenna mast)	N/A	N/A	CO3000-4p
Innco system	MA4640/800-XP-EP / Antenna Position Tower	N/A	N/A	N/A
Emco	2090 / Controller	N/A	N/A	060520
Ets	- / Turn Table	N/A	N/A	N/A
Rohde&Schwarz	- / Loop Antenna	04/19/2017	Biennial	1513-175
Schwarzbeck	VULB 9168 / Hybrid Antenna	04/06/2017	Biennial	760
Schwarzbeck	BBHA 9120D / Horn Antenna	06/30/2017	Biennial	9120D-1300
Schwarzbeck	BBHA9170 / Horn Antenna(15 GHz ~ 40 GHz)	04/25/2017	Biennial	BBHA9170124
Rohde&Schwarz	FSP / Spectrum Analyzer	09/19/2018	Annual	836650/016
Wainwright Instruments	WHKX10-900-1000-15000-40SS / High Pass Filter	07/20/2018	Annual	5
Wainwright Instruments	WHKX10-2700-3000-18000-40SS / High Pass Filter	07/20/2018	Annual	3
CERNEX	CBLU1183540 / Power Amplifier	01/03/2018	Annual	24613
CERNEX	CBL06185030 / Power Amplifier	01/03/2018	Annual	24615
CERNEX	CBL18265035 / Power Amplifier	01/10/2018	Annual	22966

## 5. TEST RESULT

### 5.1. AGC THRESHOLD

**Test Requirement:**

**KDB 935210 D05 v01r02**

Testing at and above the AGC threshold is required.

**Test Procedures:**

Measurements were in accordance with the test methods section 3.2 of KDB 935210 D05 v01r02.

*In the case of fiber-optic distribution systems, the RF input port of the equipment under test (EUT) refers to the RF input of the supporting equipment RF to optical convertor; see also descriptions and diagrams for typical DAS booster systems in KDB Publication 935210 D02*

*Devices intended to be directly connected to an RF source (donor port) only need to be evaluated for any over-the-air transmit paths.*

- a) Connect a signal generator to the input of the EUT.
- b) Connect a spectrum analyzer or power meter to the output of the EUT using appropriate attenuation as necessary.
- c) The signal generator should initially be configured to produce either of the required test signals.
- d) Set the signal generator frequency to the center frequency of the EUT operating band.
- e) While monitoring the output power of the EUT, measured using the methods of ANSI C63.26-2015 subclause 5.2.4.4.1, increase the input level until a 1 dB increase in the input signal power no longer causes a 1 dB increase in the output signal power.
- f) Record this level as the AGC threshold level.
- g) Repeat the procedure with the remaining test signal.

Output power measurement in subclause 5.2.4.4.1 of ANSI C63.26

- a) Set span to  $2 \times$  to  $3 \times$  the OBW.
- b) Set RBW = 1% to 5% of the OBW.
- c) Set VBW  $\geq 3 \times$  RBW.
- d) Set number of measurement points in sweep  $\geq 2 \times$  span / RBW.
- e) Sweep time: auto-couple
- f) Detector = power averaging (rms).
- g) If the EUT can be configured to transmit continuously, then set the trigger to free run.
- h) Omit
- i) Trace average at least 100 traces in power averaging (rms) mode if sweep is set to auto-couple. To

accurately determine the average power over multiple symbols, it can be necessary to increase the number of traces to be averaged above 100 or, if using a manually configured sweep time, increase the sweep time.

j) Compute the power by integrating the spectrum across the OBW of the signal using the instrument's band or channel power measurement function, with the band/channel limits set equal to the OBW band edges. If the instrument does not have a band or channel power function, then sum the spectrum levels (in linear power units) at intervals equal to the RBW extending across the entire OBW of the spectrum.

**Test Results:**

Test Band	Link	Signal	Center Frequency (MHz)	AGC Threshold Level (dBm)	Output Level (dBm)
Lower 700 MHz	Uplink	LTE 10 MHz	710.00	-40	20.15
	Downlink	LTE 10 MHz	740.00	-55	4.80
Upper 700 MHz	Uplink	LTE 10 MHz	781.50	-40	19.76
	Downlink	LTE 10 MHz	751.00	-55	5.22
Cellular	Uplink	CDMA	836.50	-40	19.53
		LTE 5 MHz	836.50	-40	20.21
	Downlink	CDMA	881.50	-55	5.11
		LTE 5 MHz	881.50	-55	4.95
AWS-1	Uplink	LTE 10 MHz	1 732.50	-45	19.39
	Downlink	LTE 10 MHz	2 132.50	-60	4.78
Broadband PCS	Uplink	CDMA	1 882.50	-45	19.92
		LTE 20 MHz	1 882.50	-45	20.22
	Downlink	CDMA	1 962.50	-60	4.62
		LTE 20 MHz	1 962.50	-60	4.66

## 5.2. OUT-OF-BAND REJECTION

### Test Requirement:

#### KDB 935210 D05 v01r02

Out-of-band rejection required.

### Test Procedures:

Measurements were in accordance with the test methods section 3.3 of KDB 935210 D05 v01r02.

*Adjust the internal gain control of the EUT to the maximum gain for which equipment certification is sought.*

- a) Connect a signal generator to the input of the EUT.
- b) Configure a swept CW signal with the following parameters:
  - 1) Frequency range =  $\pm 250\%$  of the passband, for each applicable CMRS band.
  - 2) Level = a sufficient level to affirm that the out-of-band rejection is  $> 20$  dB above the noise floor and will not engage the AGC during the entire sweep.
  - 3) Dwell time = approximately 10 ms.
  - 4) Number of points =  $\text{SPAN}/(\text{RBW}/2)$ .
- c) Connect a spectrum analyzer to the output of the EUT using appropriate attenuation.
- d) Set the span of the spectrum analyzer to the same as the frequency range of the signal generator.
- e) Set the resolution bandwidth (RBW) of the spectrum analyzer to be 1 % to 5 % of the EUT passband, and the video bandwidth (VBW) shall be set to  $\geq 3 \times \text{RBW}$ .
- f) Set the detector to Peak Max-Hold and wait for the spectrum analyzer's spectral display to fill.
- g) Place a marker to the peak of the frequency response and record this frequency as  $f_0$ .
- h) Place two markers, one at the lowest and the other at the highest frequency of the envelope of the spectral display, such that each marker is at or slightly below the  $-20$  dB down amplitude, to determine the 20 dB bandwidth.
- i) Capture the frequency response of the EUT.
- j) Repeat for all frequency bands applicable for use by the EUT.

**Test Results:**

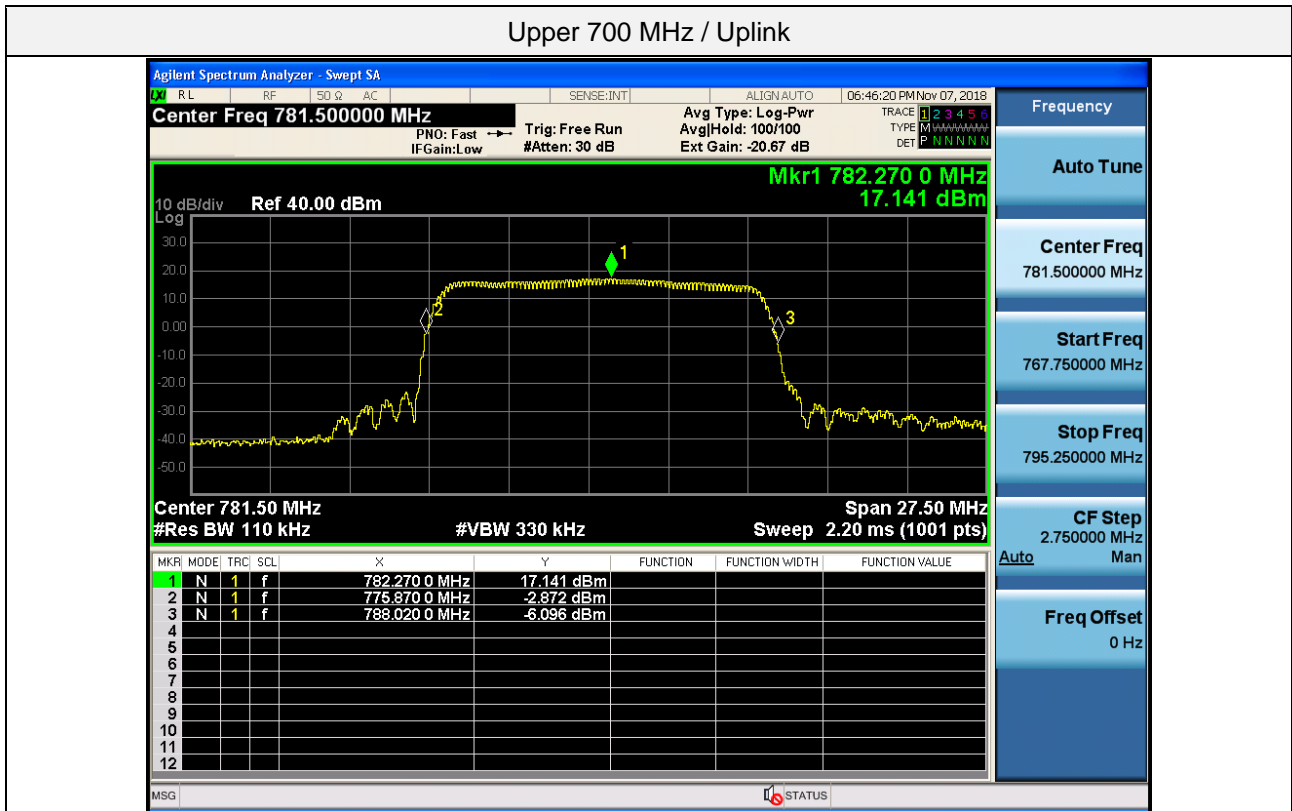
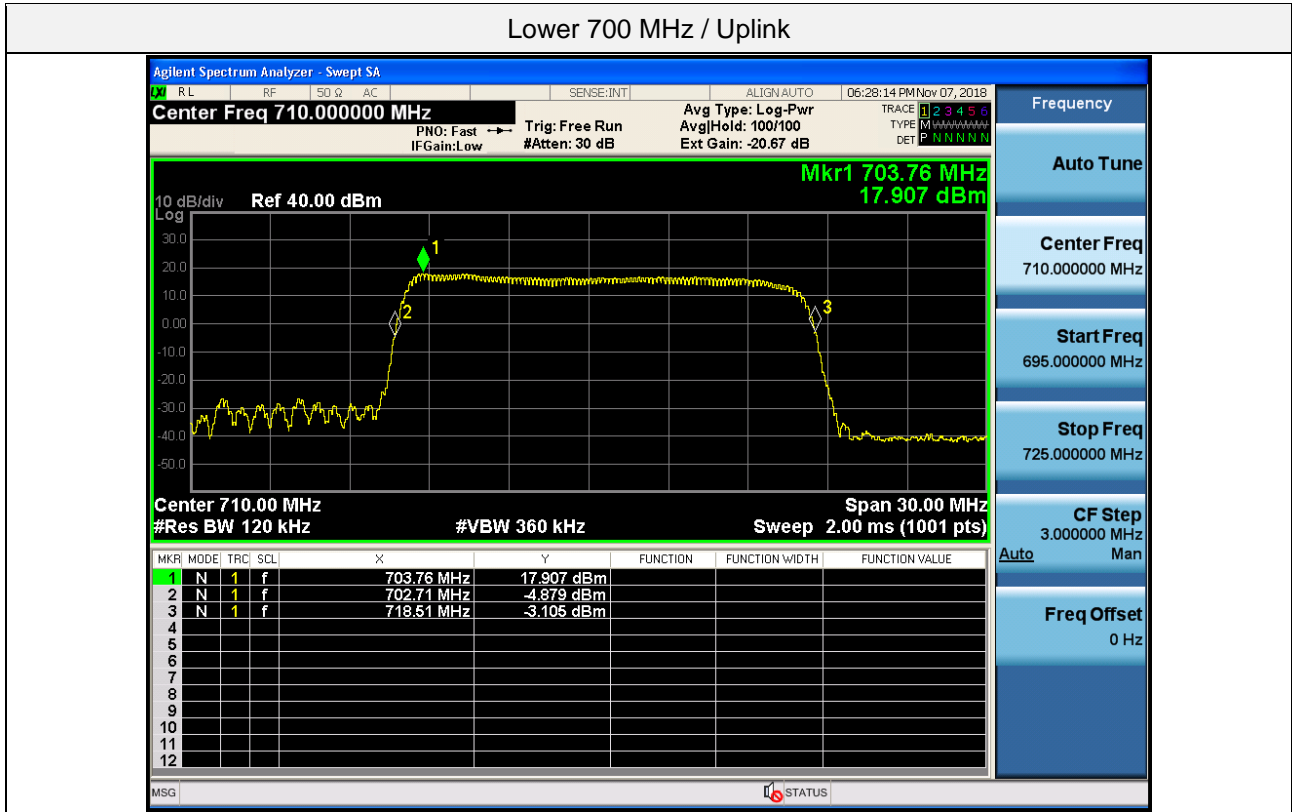

Lower + Upper 700 MHz / Downlink

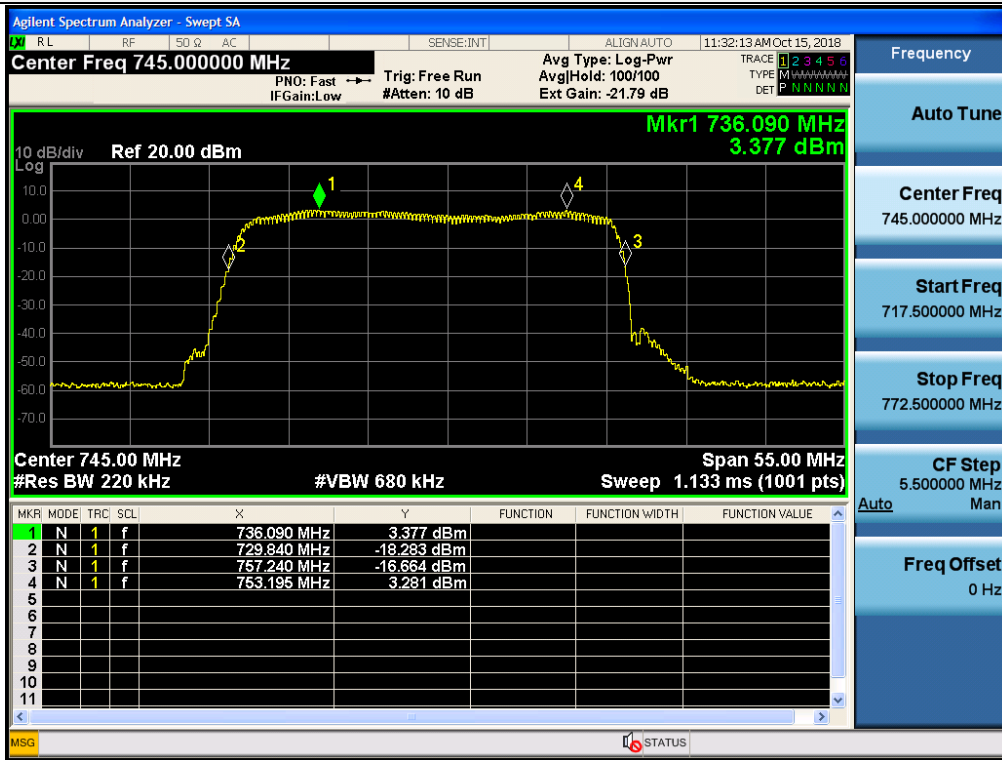

Cellular / Uplink

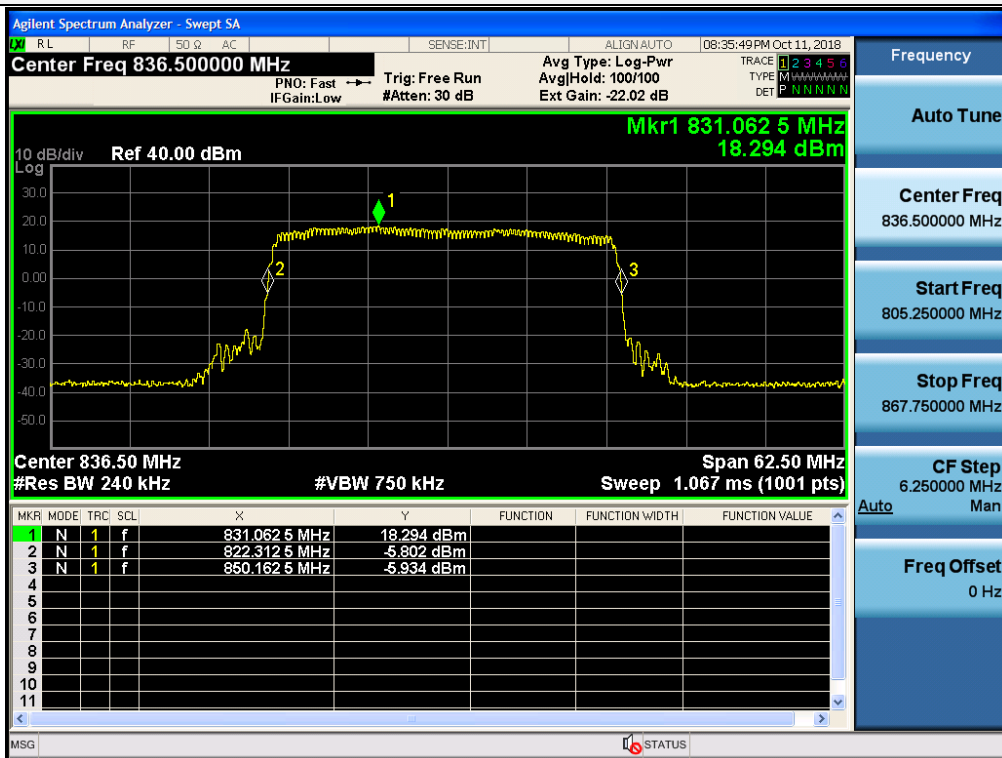



Cellular / Downlink

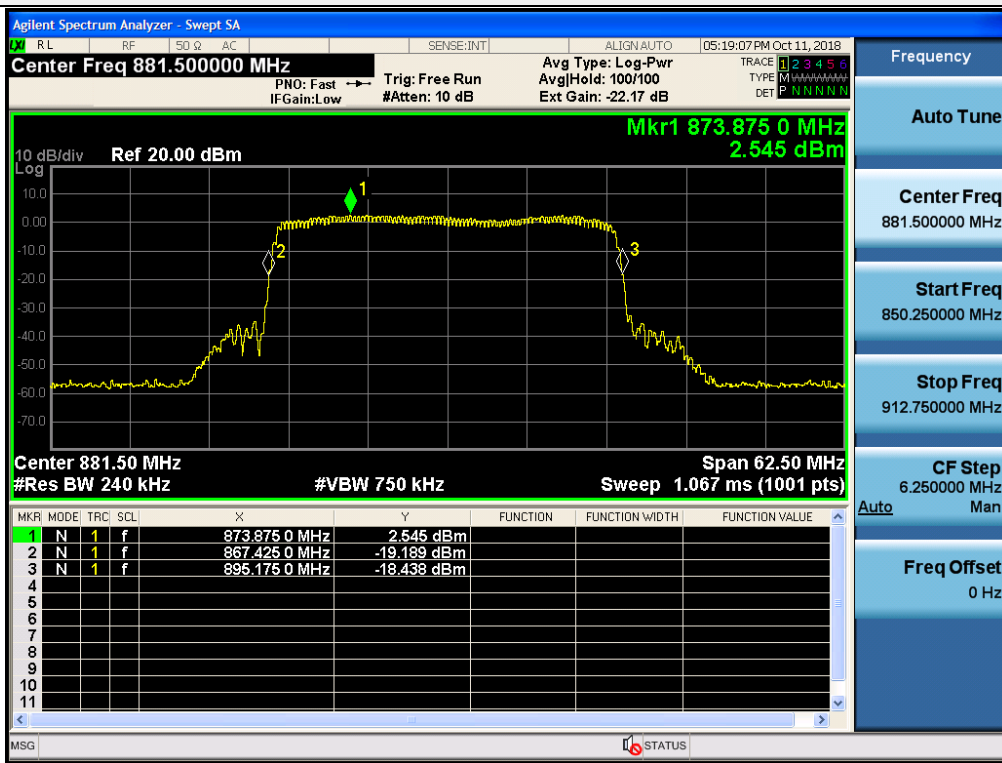

AWS-1 / Uplink

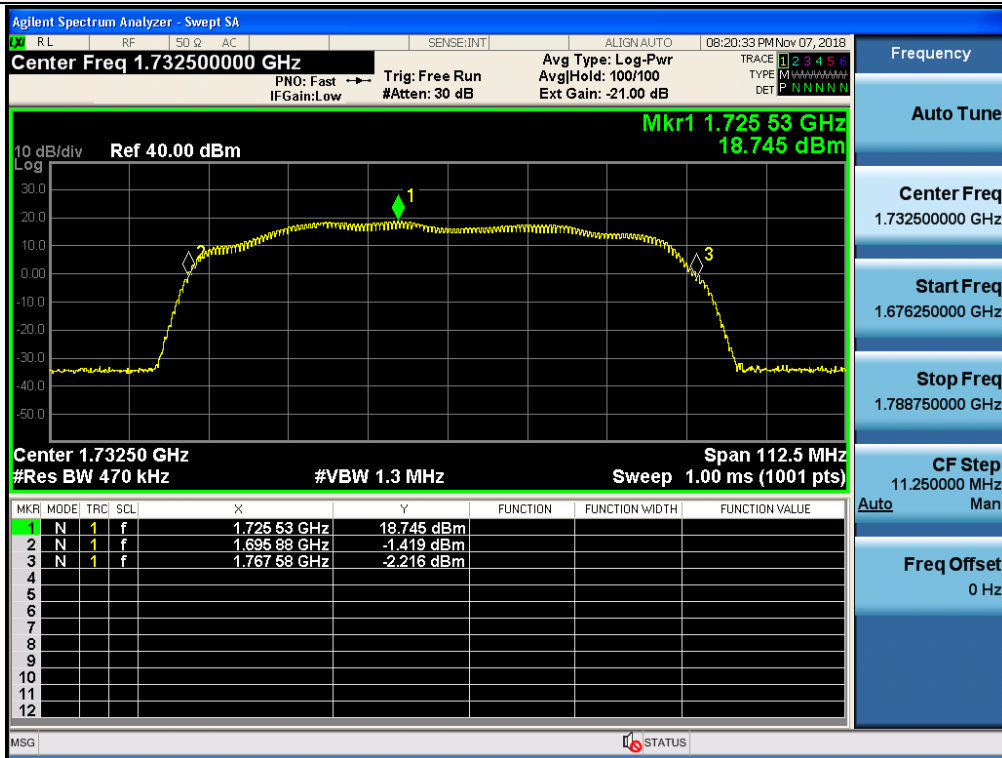

AWS-1 / Downlink

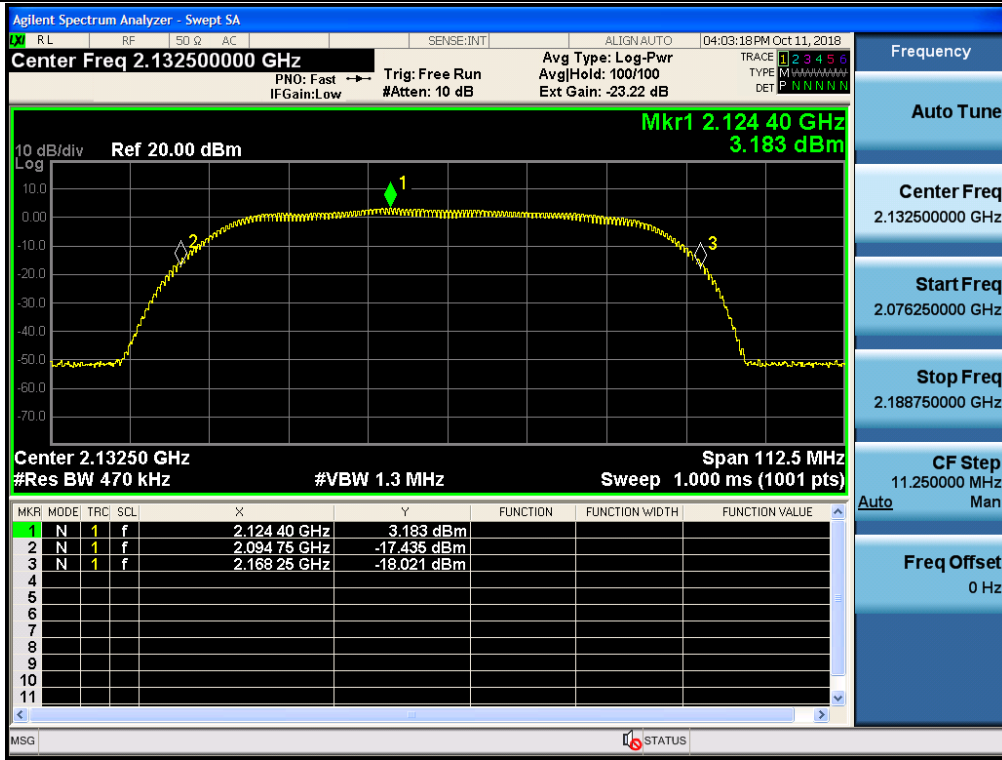

Broadband PCS / Uplink

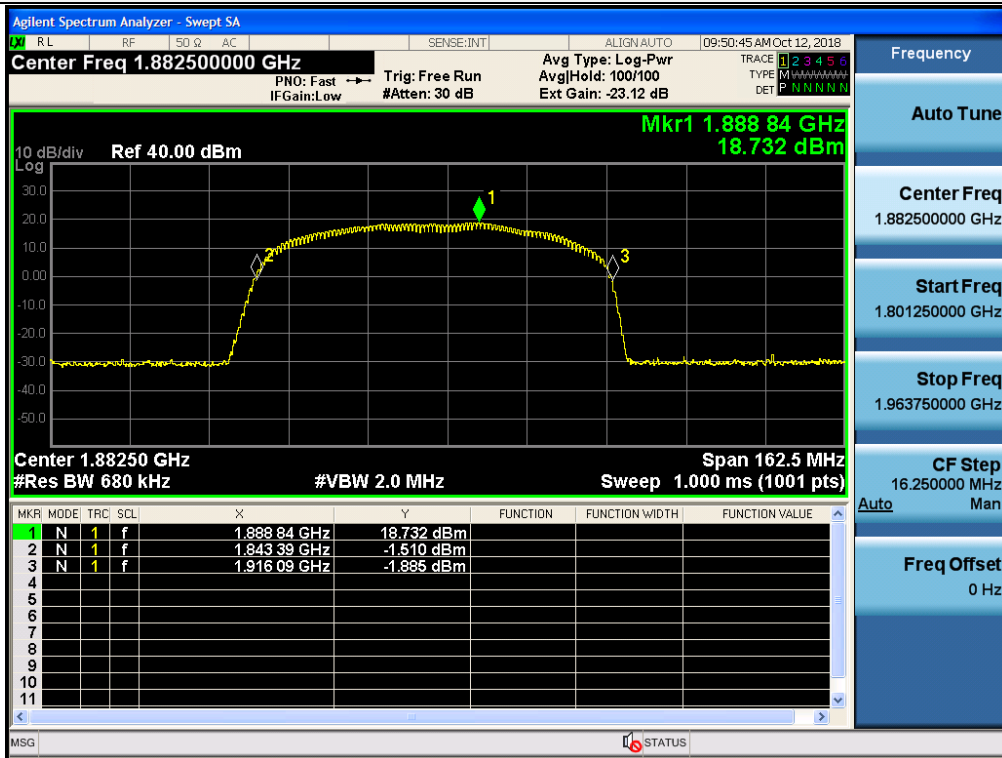

Broadband PCS / Downlink

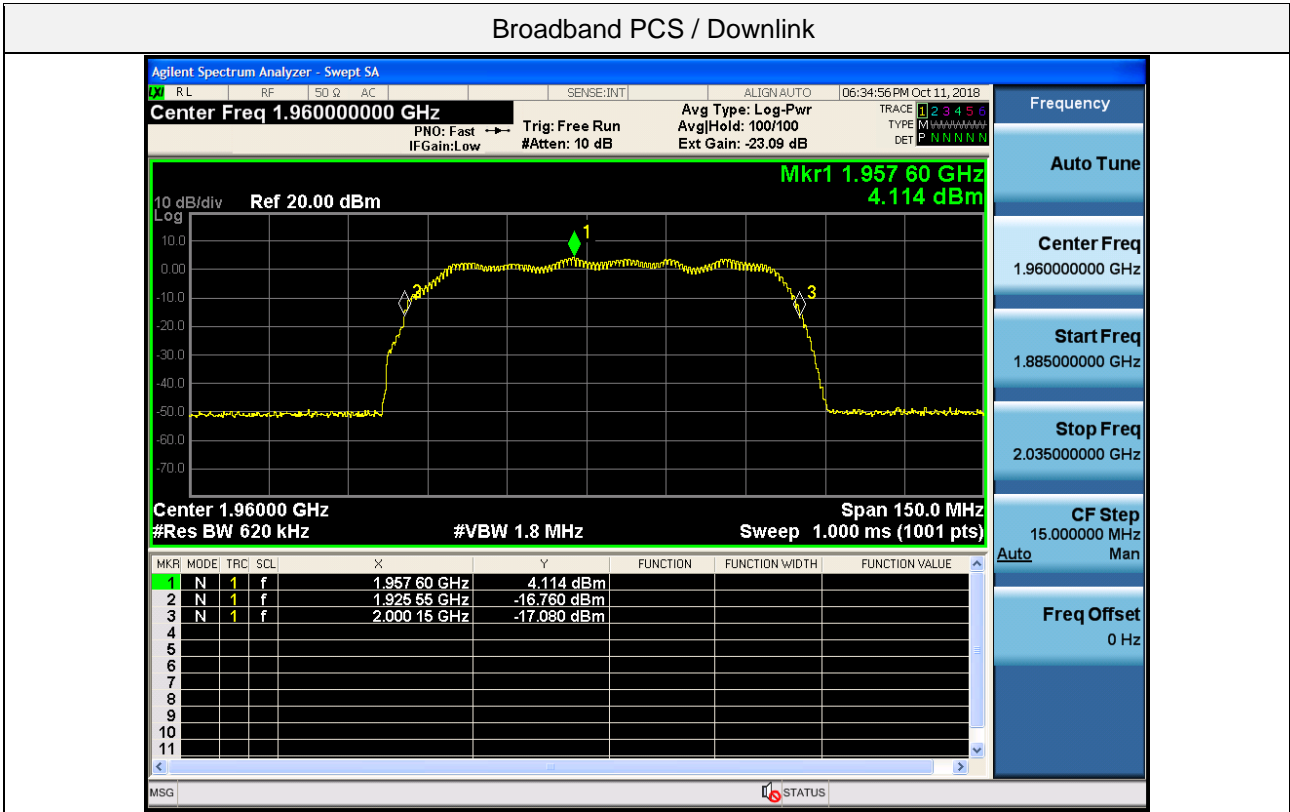

### 5.3. INPUT-VERSUS-OUTPUT SIGNAL COMPARISON

**Test Requirement:****§2.1049 Measurements required: Occupied bandwidth.**

The occupied bandwidth, that is the frequency bandwidth such that, below its lower and above its upper frequency limits, the mean powers radiated are each equal to 0.5 percent of the total mean power radiated by a given emission shall be measured under the specified conditions of § 2.1049 (a) through (i) as applicable.

**Test Procedures:**

Measurements were in accordance with the test methods section 3.4 of KDB 935210 D05 v01r02.

- a) Connect a signal generator to the input of the EUT.
- b) Configure the signal generator to transmit the AWGN signal.
- c) Configure the signal amplitude to be just below the AGC threshold level (see 3.2), but not more than 0.5 dB below.
- d) Connect a spectrum analyzer to the output of the EUT using appropriate attenuation.
- e) Set the spectrum analyzer center frequency to the center frequency of the operational band under test. The span range of the spectrum analyzer shall be between 2 times to 5 times the emission bandwidth (EBW) or alternatively, the OBW.
- f) The nominal RBW shall be in the range of 1 % to 5 % of the anticipated OBW, and the VBW shall be  $\geq 3 \times$  RBW.
- g) Set the reference level of the instrument as required to preclude the signal from exceeding the maximum spectrum analyzer input mixer level for linear operation. In general, the peak of the spectral envelope must be more than  $[10 \log (OBW / RBW)]$  below the reference level. Steps f) and g) may require iteration to enable adjustments within the specified tolerances.
- h) The noise floor of the spectrum analyzer at the selected RBW shall be at least 36 dB below the reference level.
- i) Set spectrum analyzer detection function to positive peak.
- j) Set the trace mode to max hold.
- k) Determine the reference value: Allow the trace to stabilize. Set the spectrum analyzer marker to the highest amplitude level of the displayed trace (this is the reference value) and record the associated frequency as  $f_0$ .
- l) Place two markers, one at the lowest and the other at the highest frequency of the envelope of the spectral display, such that each marker is at or slightly below the  $-26$  dB down amplitude. The 26 dB EBW (alternatively OBW) is the positive frequency difference between the two markers. If the spectral envelope crosses the  $-26$  dB down amplitude at multiple points, the lowest or highest frequency shall be selected as the frequencies that are the furthest removed from the center frequency at which the spectral envelope crosses the  $-26$  dB down amplitude point.

- m) Repeat steps e) to l) with the input signal connected directly to the spectrum analyzer (i.e., input signal measurement).
- n) Compare the spectral plot of the input signal (determined from step m) to the output signal (determined from step l) to affirm that they are similar (in passband and rolloff characteristic features and relative spectral locations), and include plot(s) and descriptions in test report.
- o) Repeat the procedure [steps e) to n)] with the input signal amplitude set to 3 dB above the AGC threshold.
- p) Repeat steps e) to o) with the signal generator set to the narrowband signal.
- q) Repeat steps e) to p) for all frequency bands authorized for use by the EUT.

**Test Results:**

**Tabular data of Output Occupied Bandwidth**

Test Band	Link	Signal	Center Frequency (MHz)	99 % OBW (MHz)	26 dB OBW (MHz)
Lower 700 MHz	Uplink	LTE 10 MHz	710.00	9.0142	9.996
	Downlink	LTE 10 MHz	740.00	8.9946	9.879
Upper 700 MHz	Uplink	LTE 10 MHz	781.50	8.9653	9.867
	Downlink	LTE 10 MHz	751.00	8.9695	9.921
Cellular	Uplink	CDMA	836.50	1.2420	1.372
		LTE 5 MHz	836.50	4.5363	5.054
	Downlink	CDMA	881.50	1.2409	1.362
		LTE 5 MHz	881.50	4.5116	5.029
AWS-1	Uplink	LTE 10 MHz	1 732.50	9.0519	10.253
	Downlink	LTE 10 MHz	2 132.50	9.0116	10.027
Broadband PCS	Uplink	CDMA	1 882.50	1.2427	1.367
		LTE 20 MHz	1 882.50	18.008	19.79
	Downlink	CDMA	1 962.50	1.2383	1.366
		LTE 20 MHz	1 962.50	17.867	19.73

**Tabular data of Input Occupied Bandwidth**

Test Band	Link	Signal	Center Frequency (MHz)	99 % OBW (MHz)	26 dB OBW (MHz)
Lower 700 MHz	Uplink	LTE 10 MHz	710.00	9.0020	9.994
	Downlink	LTE 10 MHz	740.00	9.0101	10.031
Upper 700 MHz	Uplink	LTE 10 MHz	781.50	8.9988	9.912
	Downlink	LTE 10 MHz	751.00	9.0024	9.982
Cellular	Uplink	CDMA	836.50	1.2367	1.367
		LTE 5 MHz	836.50	4.5118	5.042
	Downlink	CDMA	881.50	1.2400	1.364
		LTE 5 MHz	881.50	4.5191	5.022
AWS-1	Uplink	LTE 10 MHz	1 732.50	8.9937	10.049
	Downlink	LTE 10 MHz	2 132.50	9.0212	9.978
Broadband PCS	Uplink	CDMA	1 882.50	1.2404	1.365
		LTE 20 MHz	1 882.50	17.975	19.82
	Downlink	CDMA	1 962.50	1.2410	1.368
		LTE 20 MHz	1 962.50	18.007	20.03

**Tabular data of 3 dB above the AGC threshold Output Occupied Bandwidth**

Test Band	Link	Signal	Center Frequency (MHz)	99 % OBW (MHz)	26 dB OBW (MHz)
Lower 700 MHz	Uplink	LTE 10 MHz	710.00	9.0240	9.972
	Downlink	LTE 10 MHz	740.00	8.9955	9.908
Upper 700 MHz	Uplink	LTE 10 MHz	781.50	8.9875	9.847
	Downlink	LTE 10 MHz	751.00	8.9600	10.032
Cellular	Uplink	CDMA	836.50	1.2429	1.372
		LTE 5 MHz	836.50	4.5236	5.050
	Downlink	CDMA	881.50	1.2369	1.363
		LTE 5 MHz	881.50	4.5094	5.005
AWS-1	Uplink	LTE 10 MHz	1 732.50	9.0523	10.129
	Downlink	LTE 10 MHz	2 132.50	9.0079	9.950
Broadband PCS	Uplink	CDMA	1 882.50	1.2423	1.359
		LTE 20 MHz	1 882.50	17.995	20.44
	Downlink	CDMA	1 962.50	1.2398	1.357
		LTE 20 MHz	1 962.50	17.950	19.78



**Measured Occupied Bandwidth Comparison**

Test Band	Link	Signal	Variant of Input and output Occupied Bandwidth (%)	Variant of Input and 3 dB above the AGC threshold output Occupied Bandwidth (%)
Lower 700 MHz	Uplink	LTE 10 MHz	0.020	-0.220
	Downlink	LTE 10 MHz	-1.515	-1.226
Upper 700 MHz	Uplink	LTE 10 MHz	-0.454	-0.656
	Downlink	LTE 10 MHz	-0.611	0.501
Cellular	Uplink	CDMA	0.366	0.366
		LTE 5 MHz	0.238	0.159
	Downlink	CDMA	-0.147	-0.073
		LTE 5 MHz	0.139	-0.339
AWS-1	Uplink	LTE 10 MHz	2.030	0.796
	Downlink	LTE 10 MHz	0.491	-0.281
Broadband PCS	Uplink	CDMA	0.147	-0.440
		LTE 20 MHz	-0.151	3.128
	Downlink	CDMA	-0.146	-0.804
		LTE 20 MHz	-1.498	-1.248

\* Change in input-output OBW is less than  $\pm 5\%$ .

**Plot data of Occupied Bandwidth**

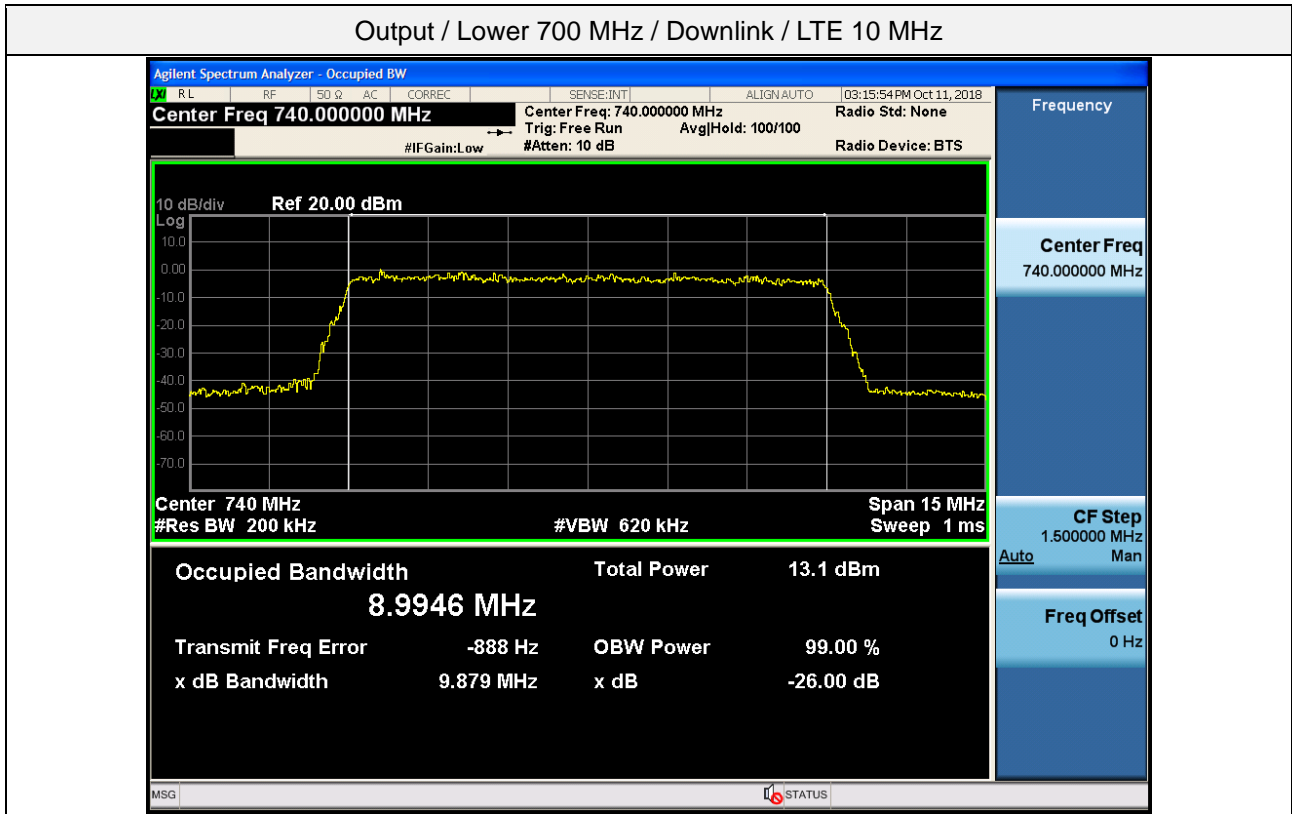
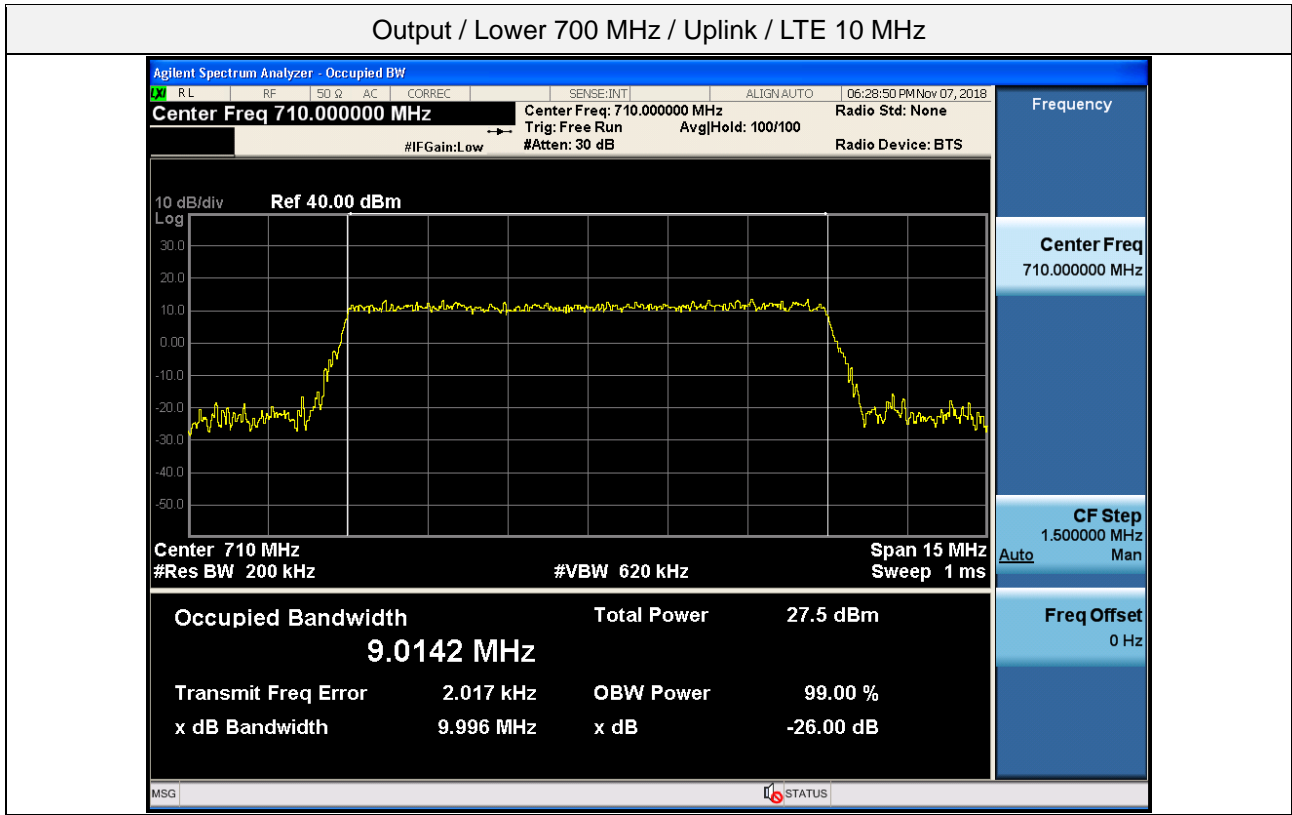

Output / Upper 700 MHz / Uplink / LTE 10 MHz

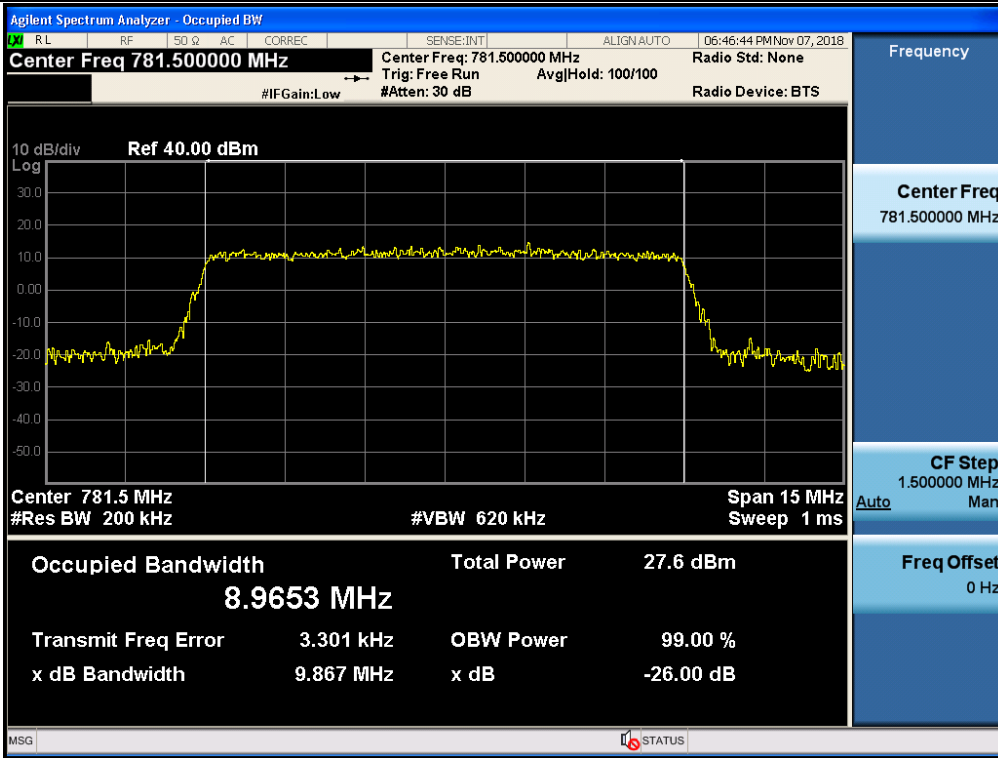

Output / Upper 700 MHz / Downlink / LTE 10 MHz

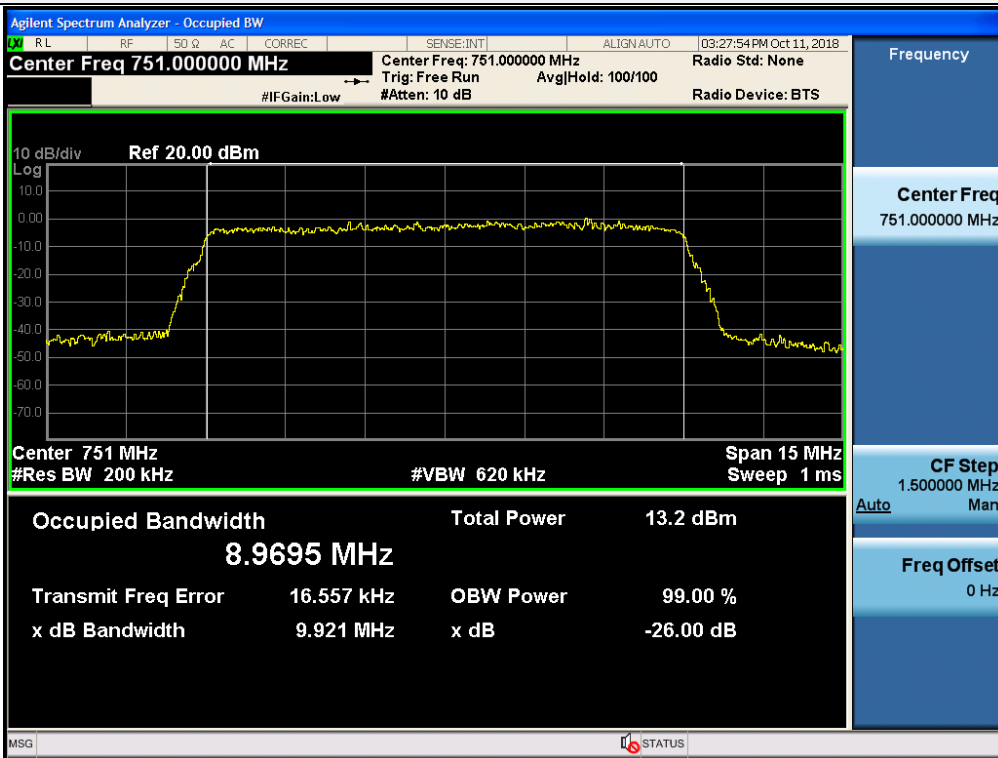

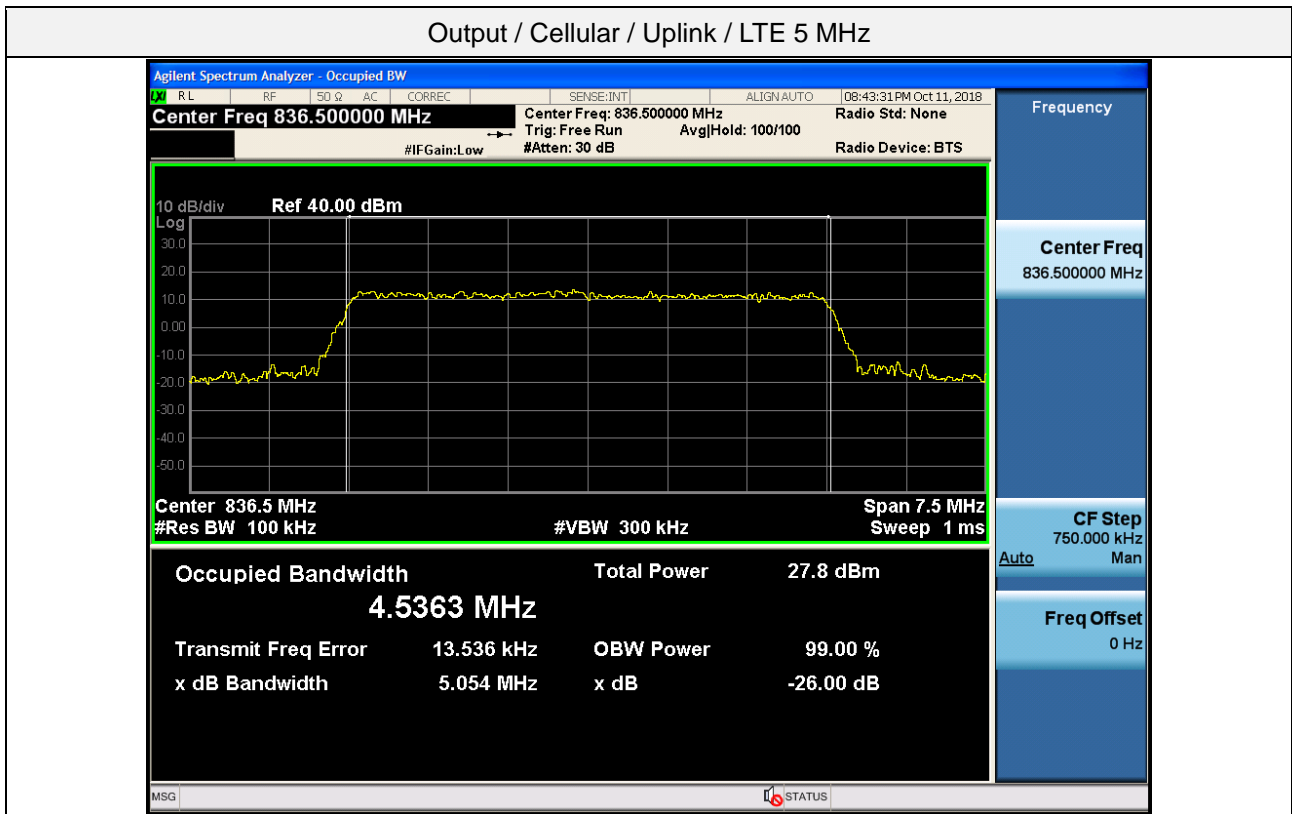
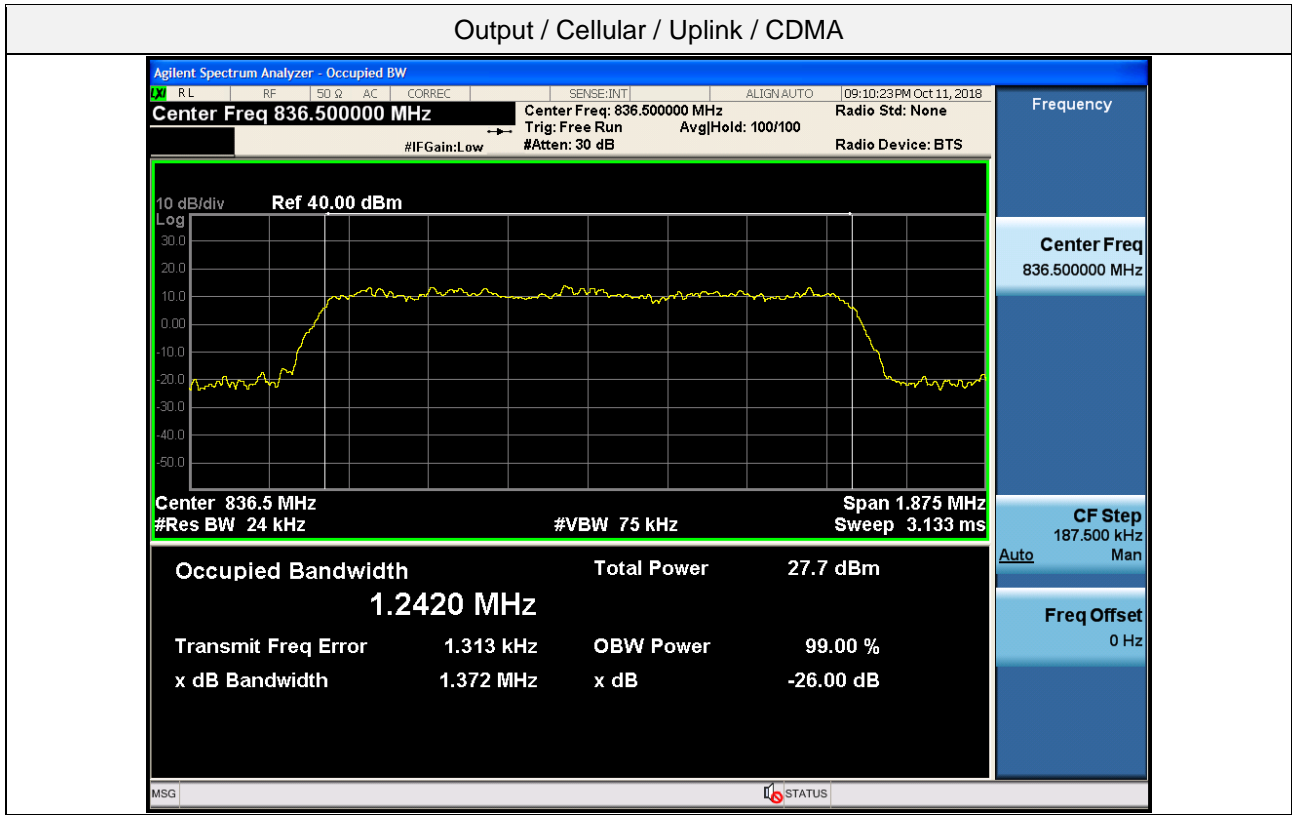

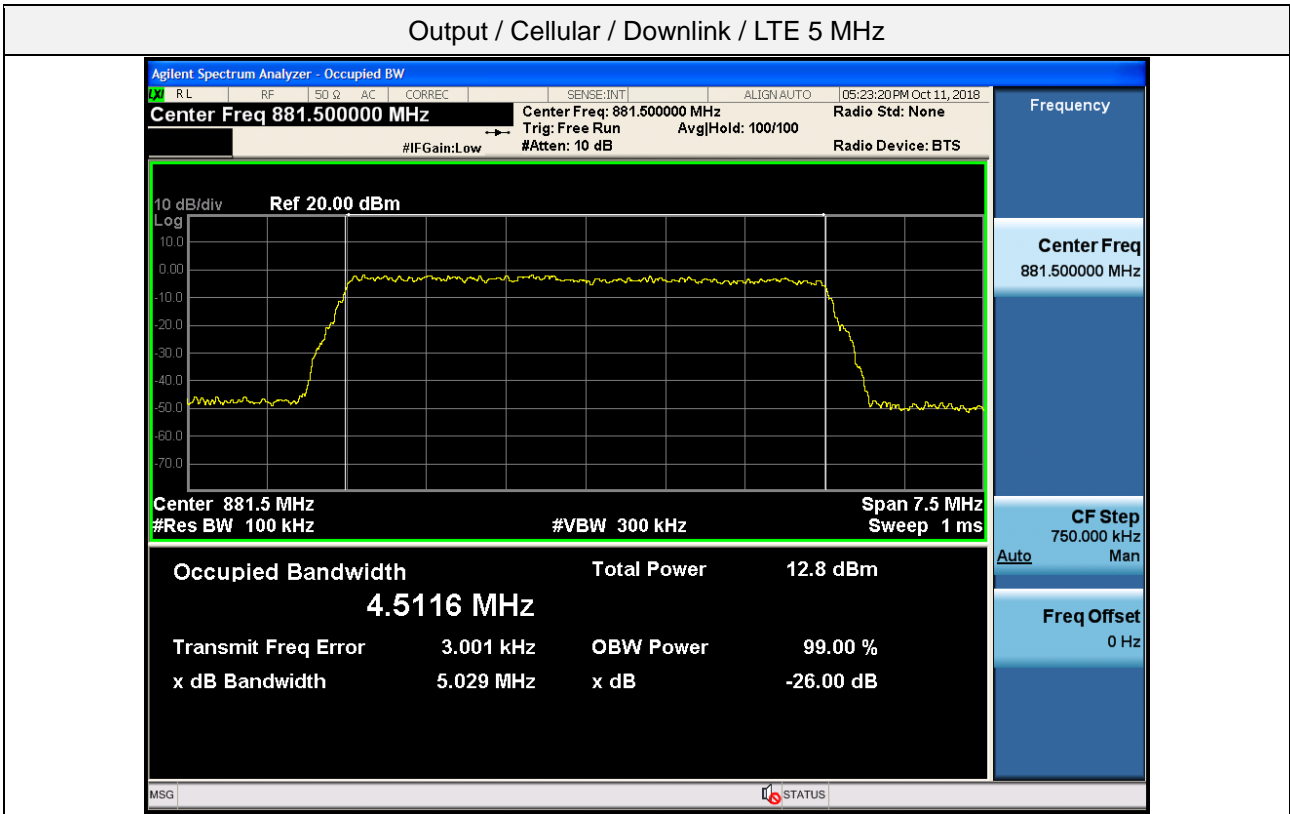
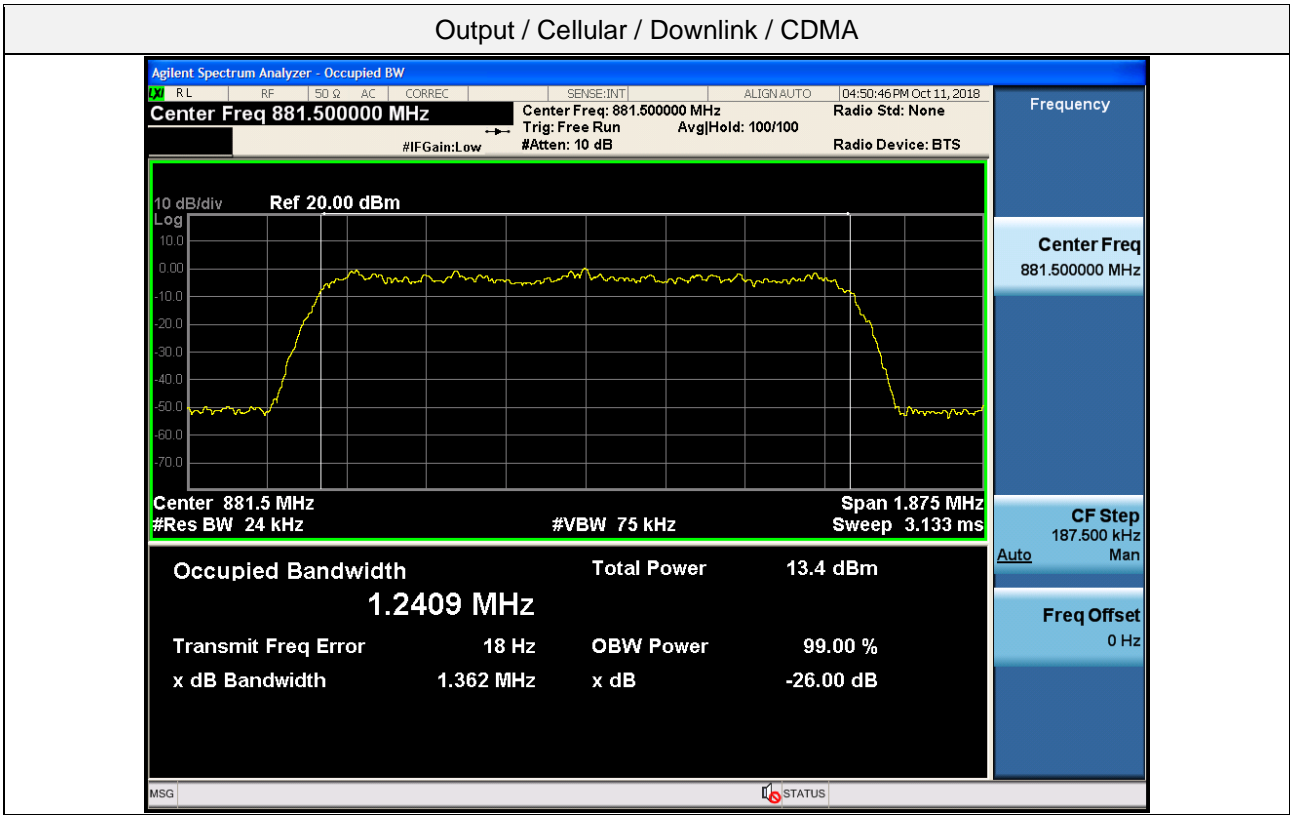

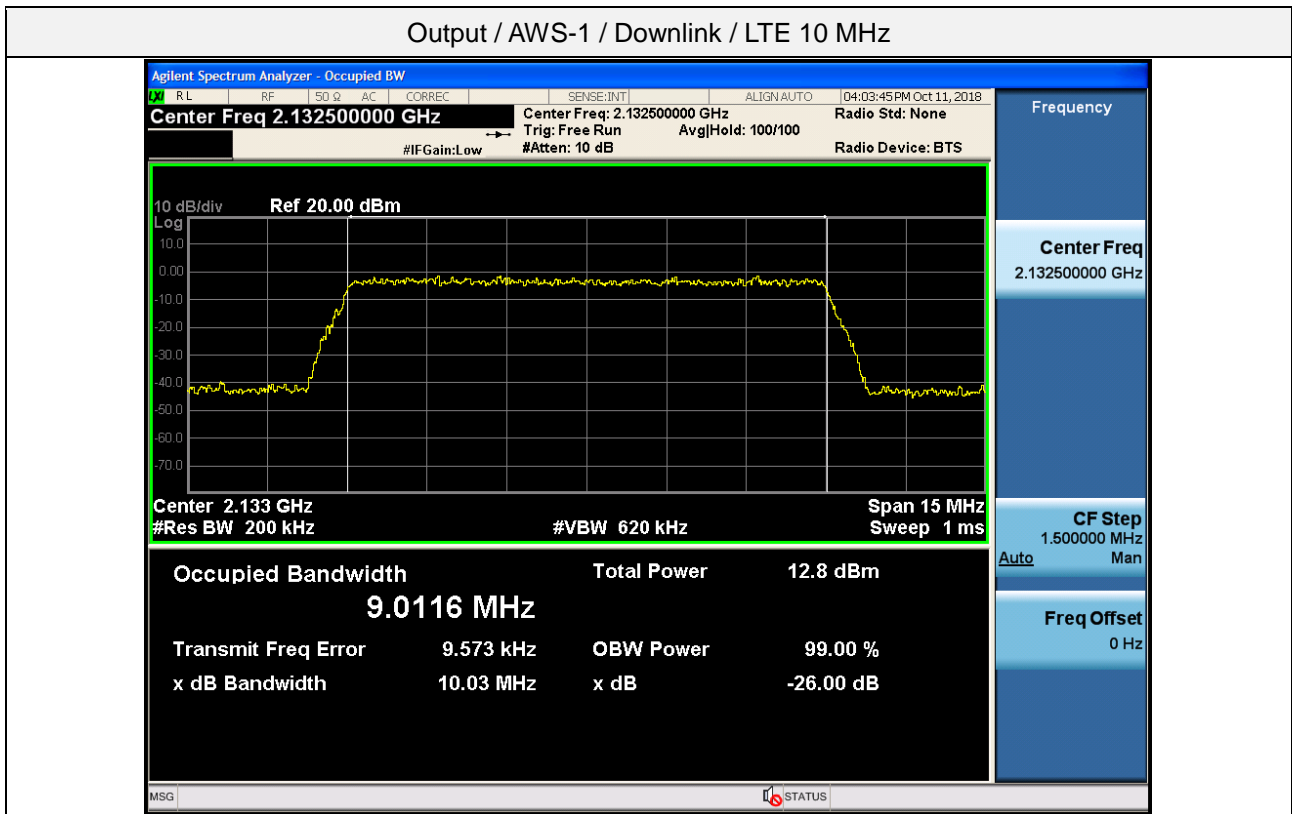
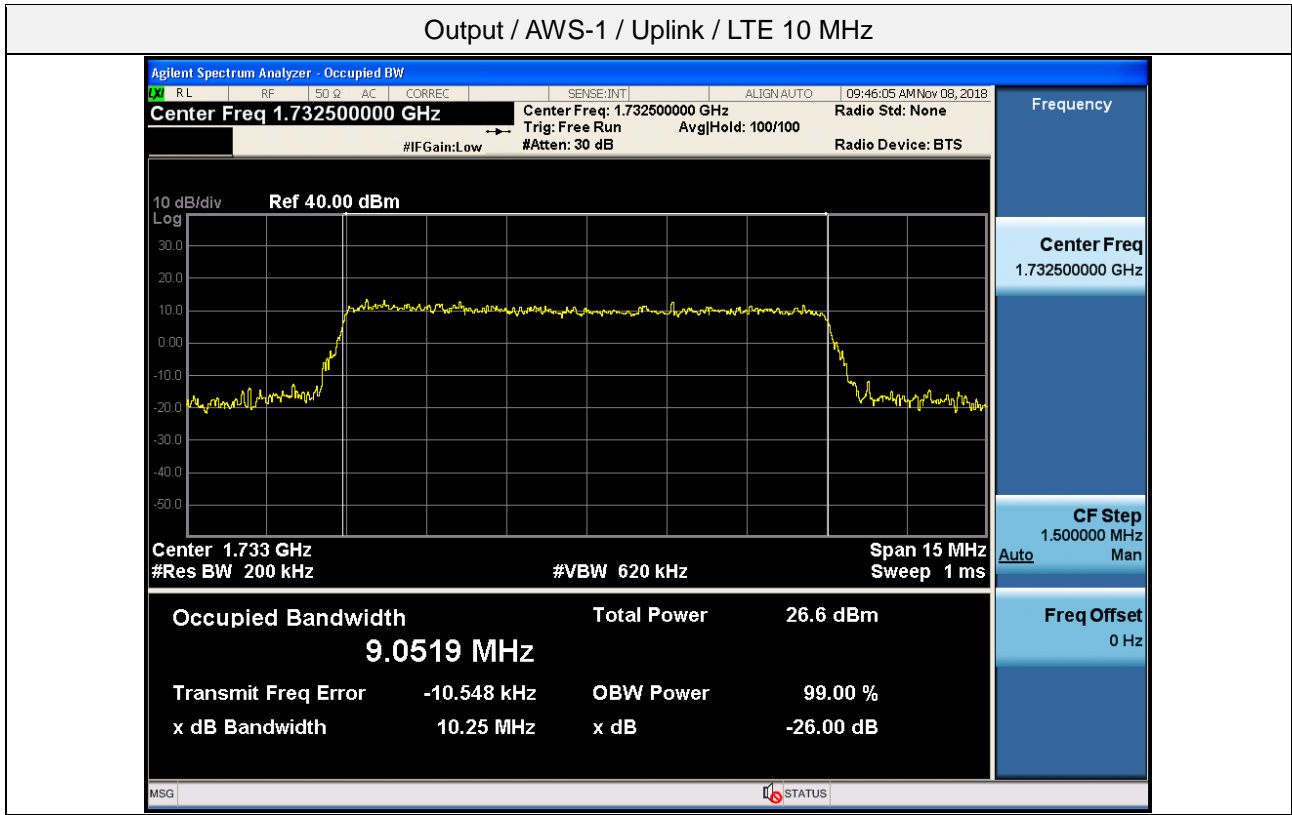

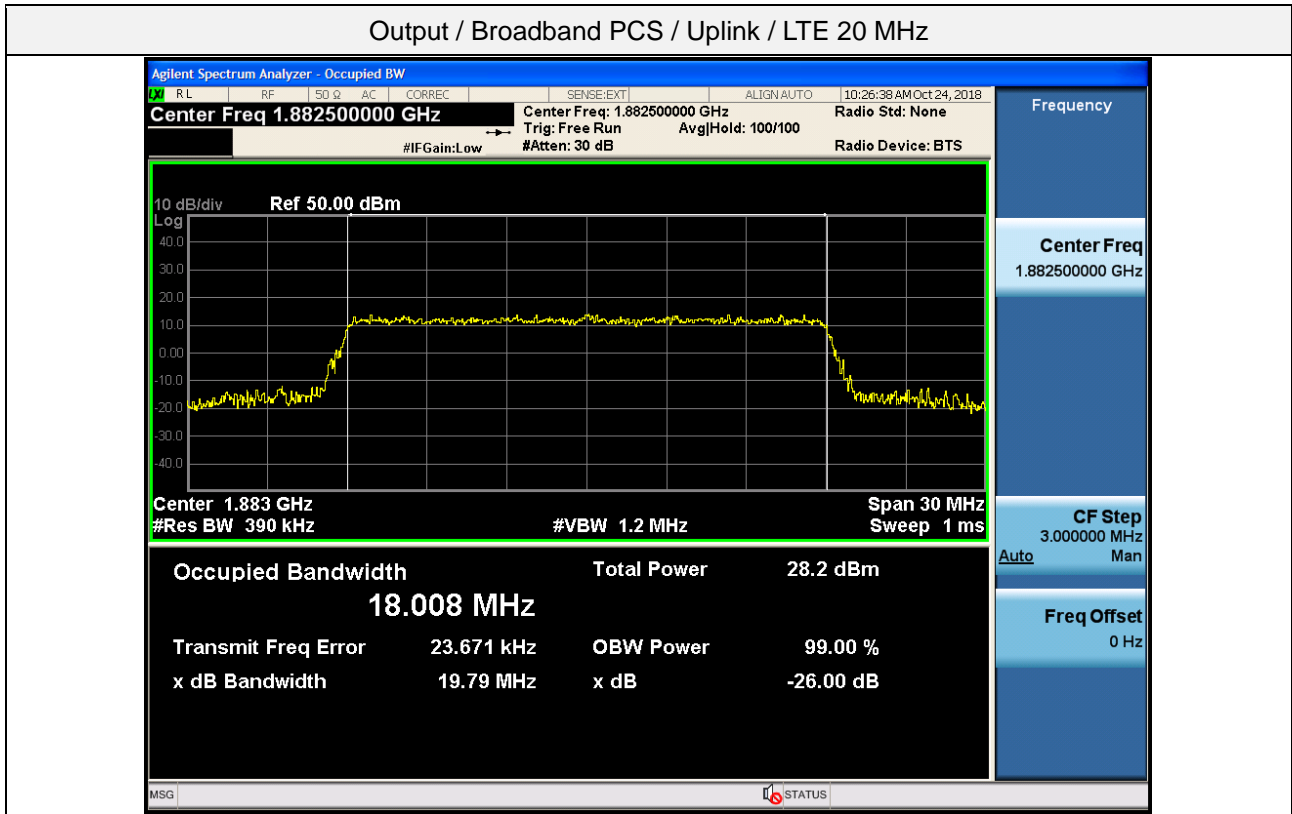
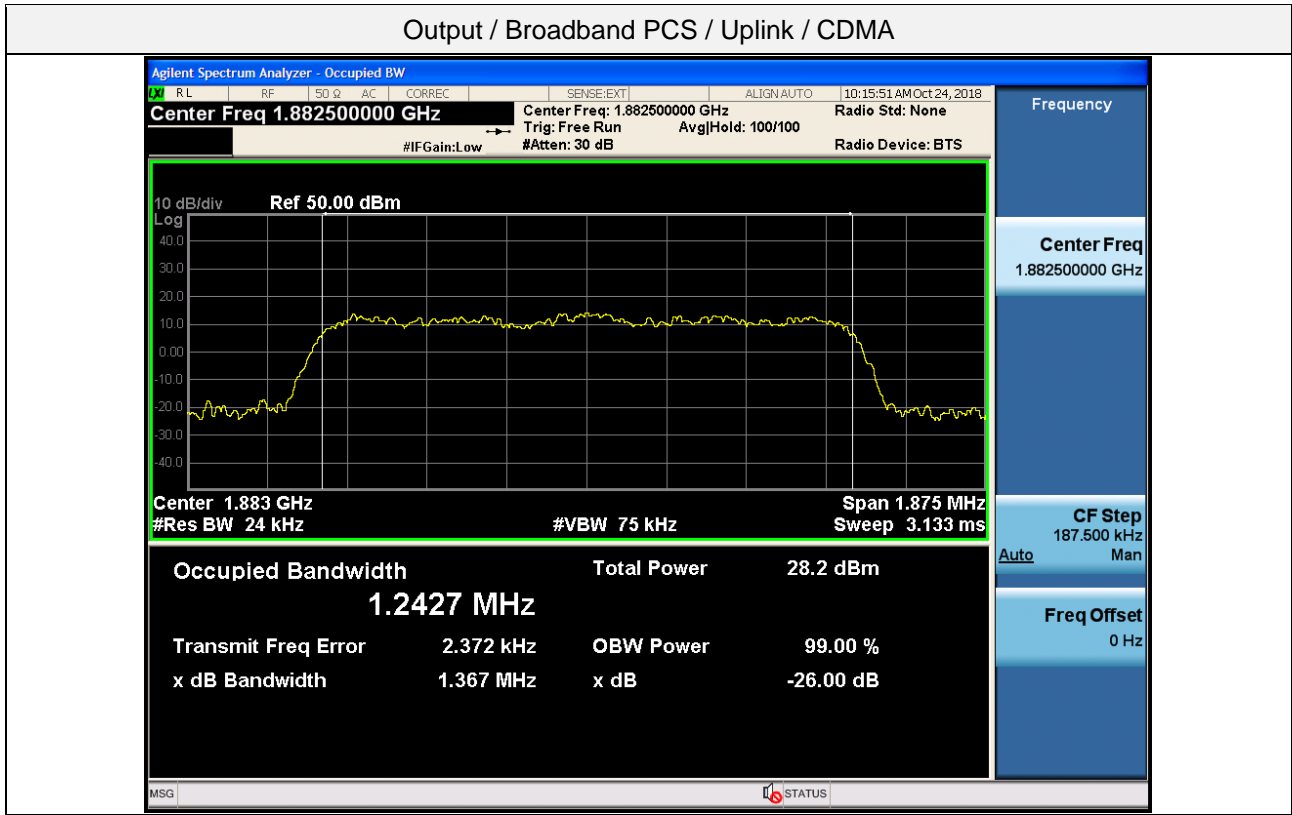

Output / Broadband PCS / Downlink / CDMA

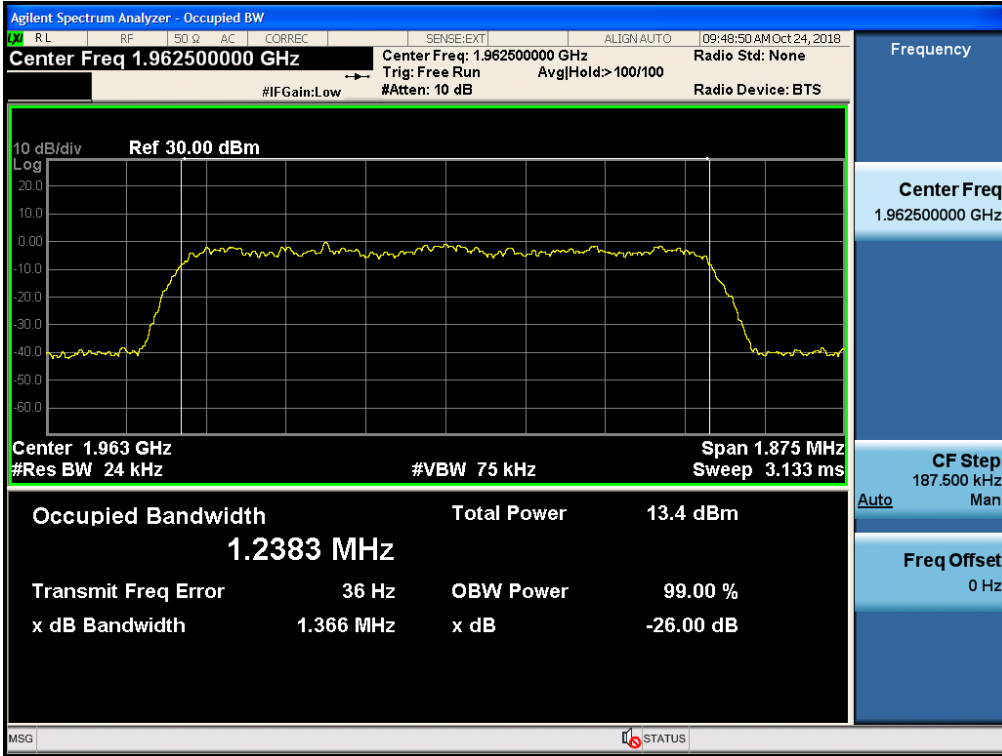

Output / Broadband PCS / Downlink / LTE 20 MHz

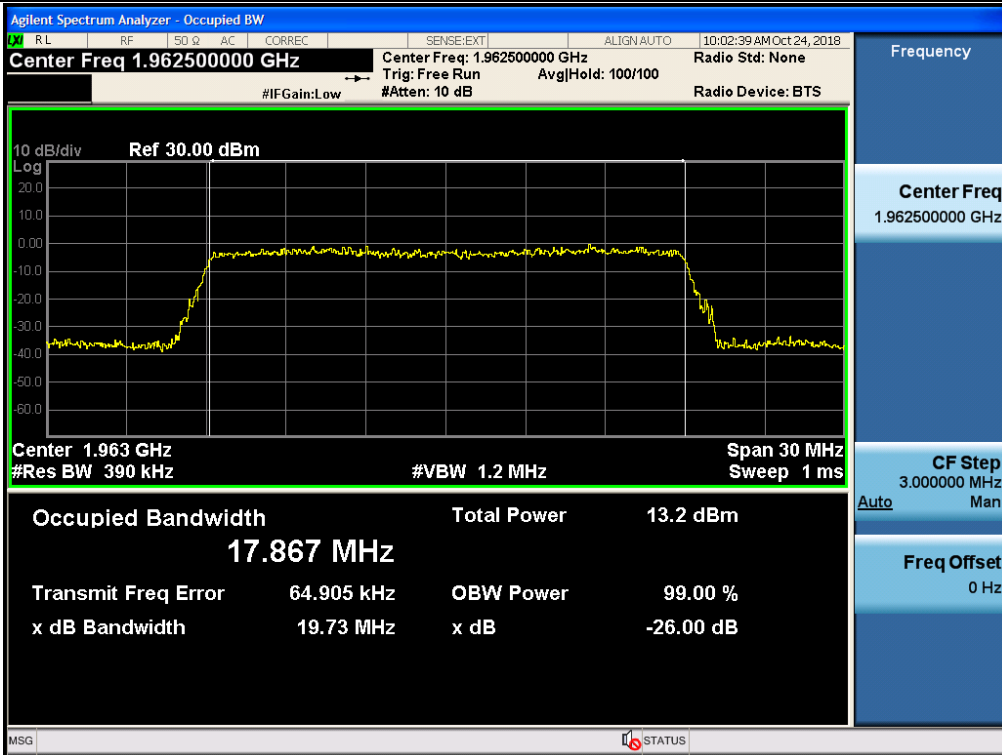



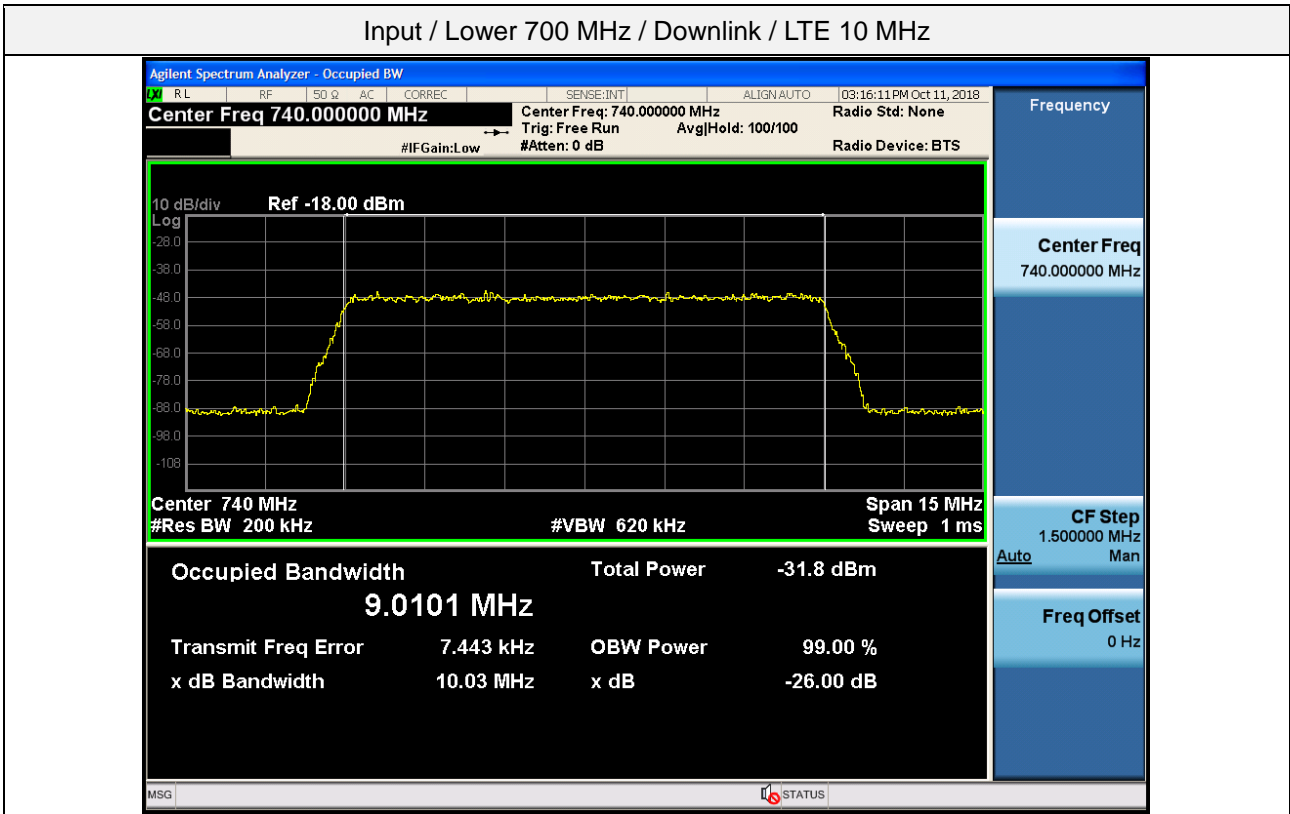
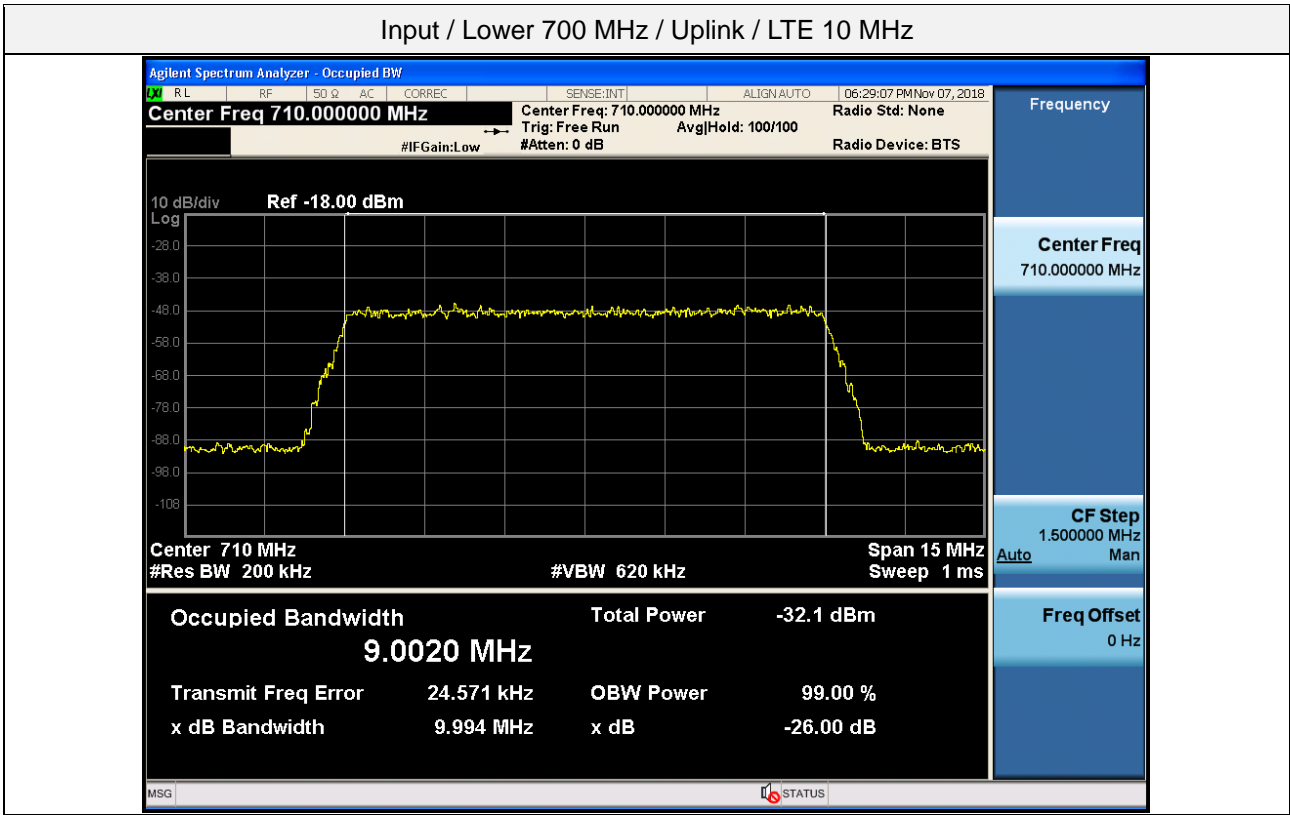

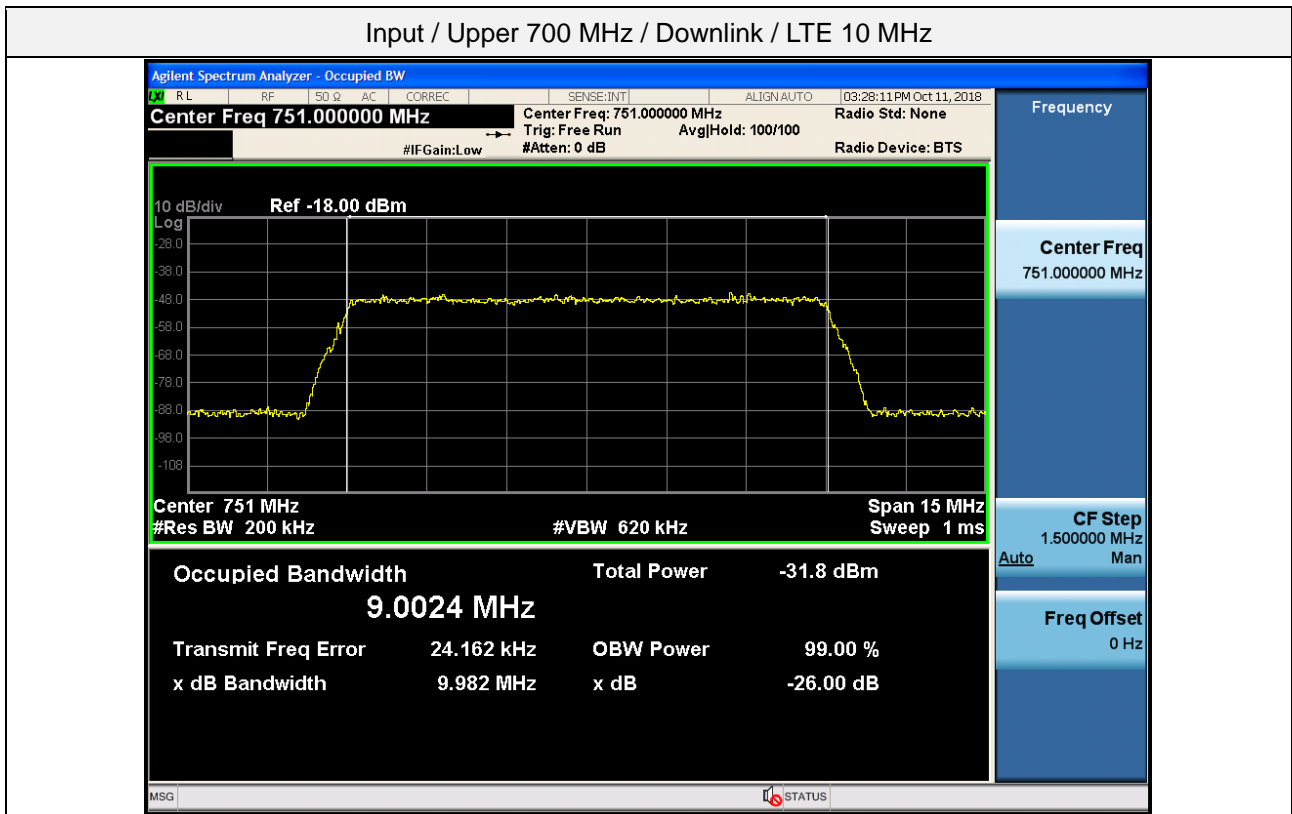
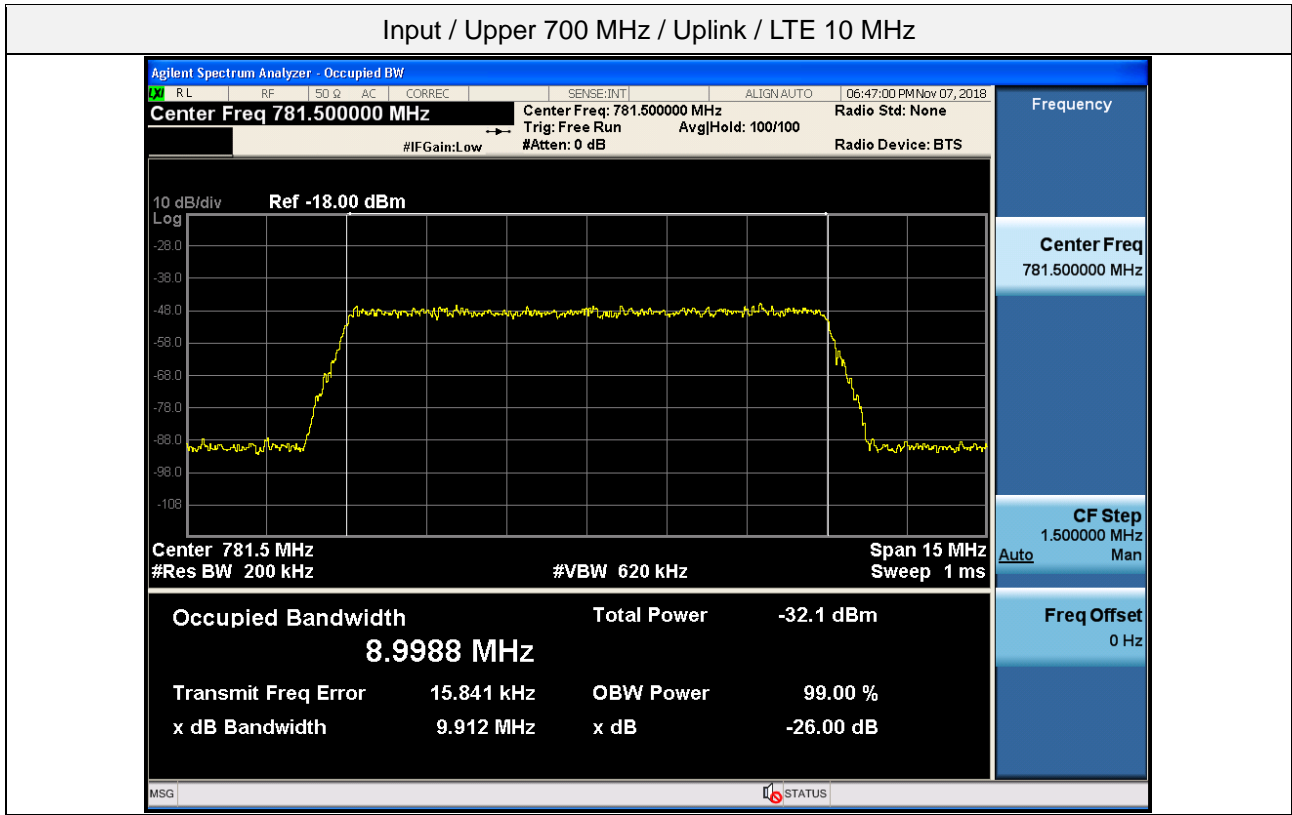

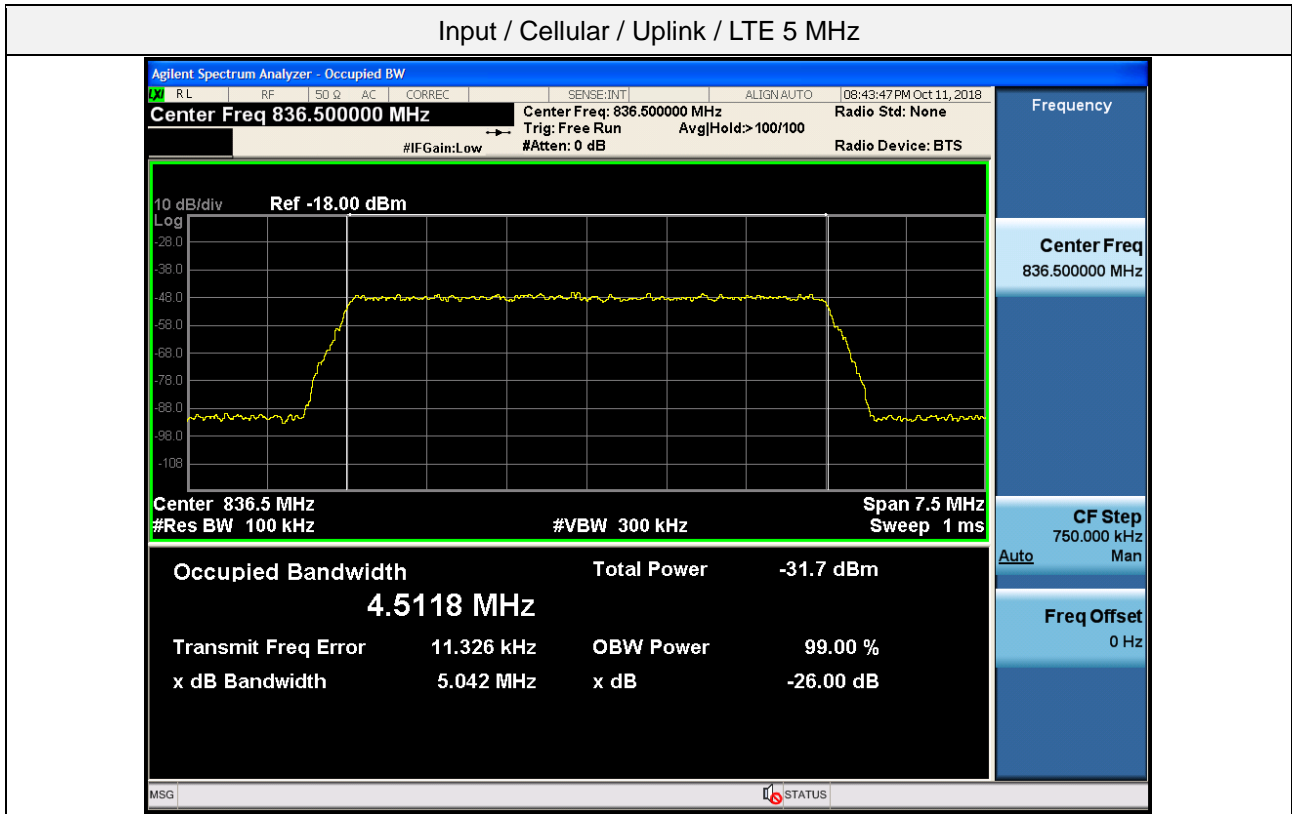
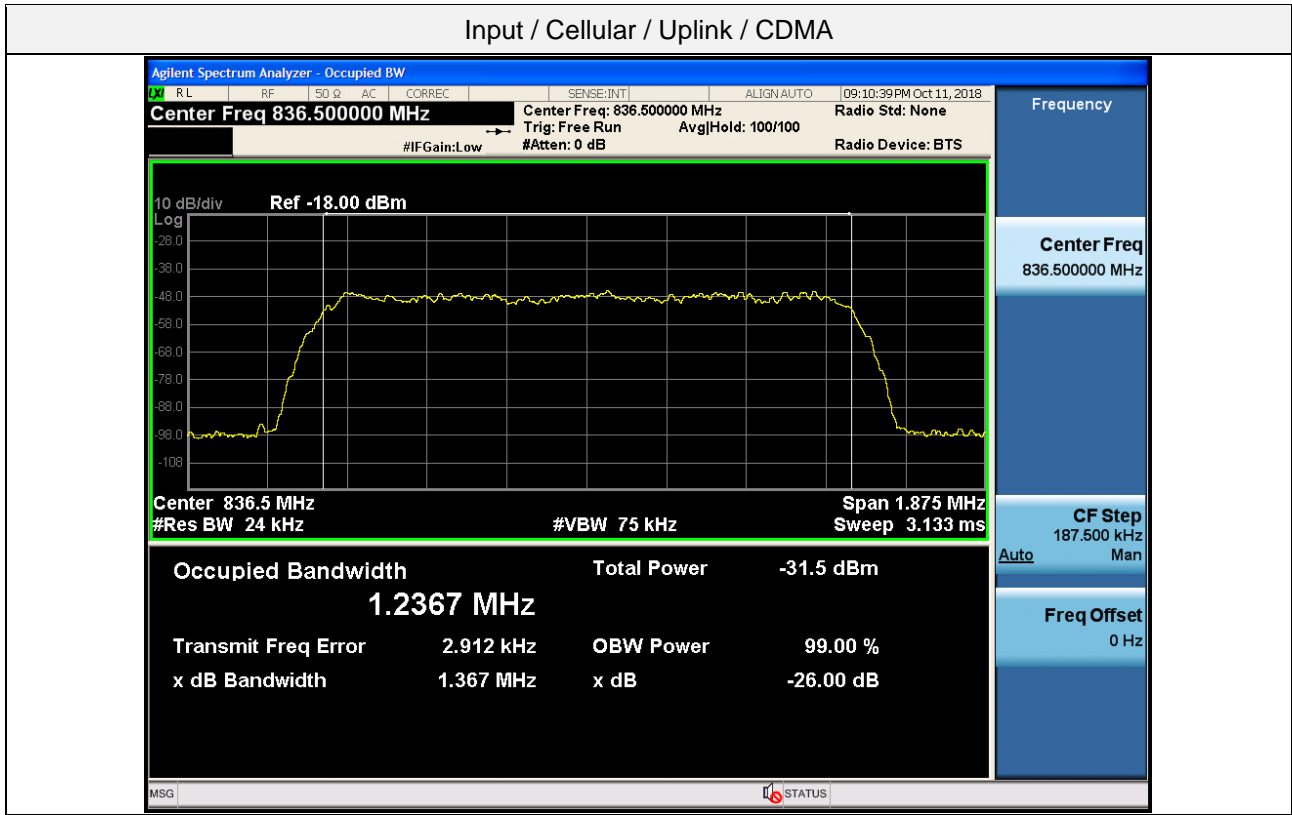

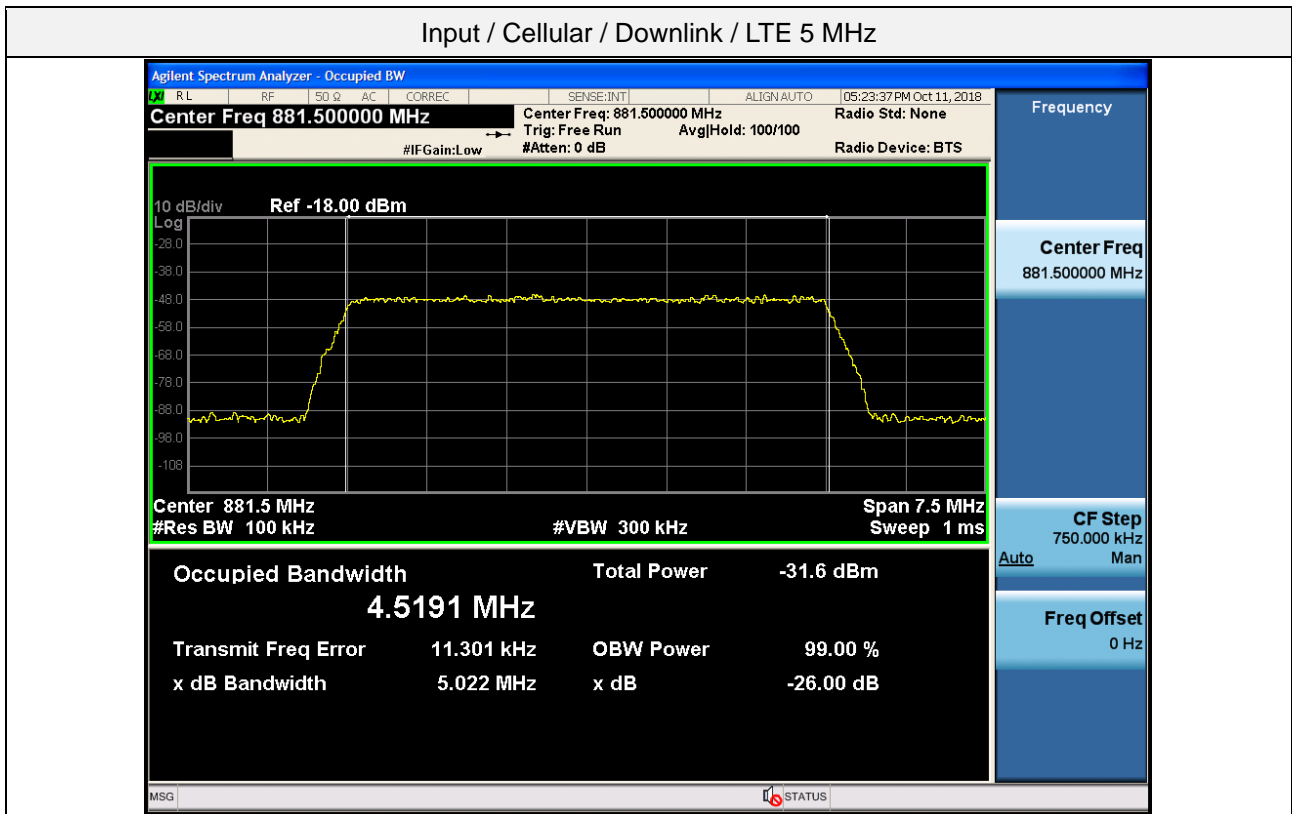
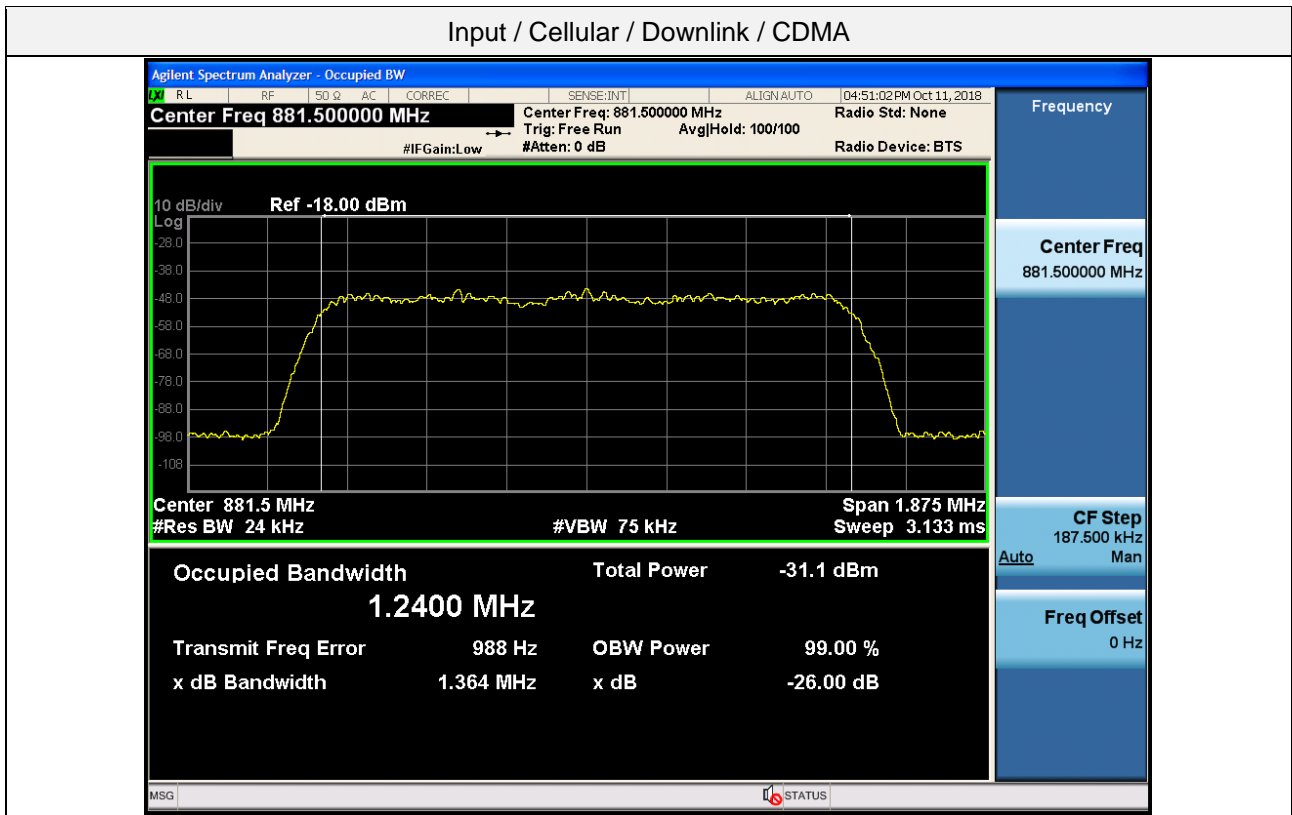

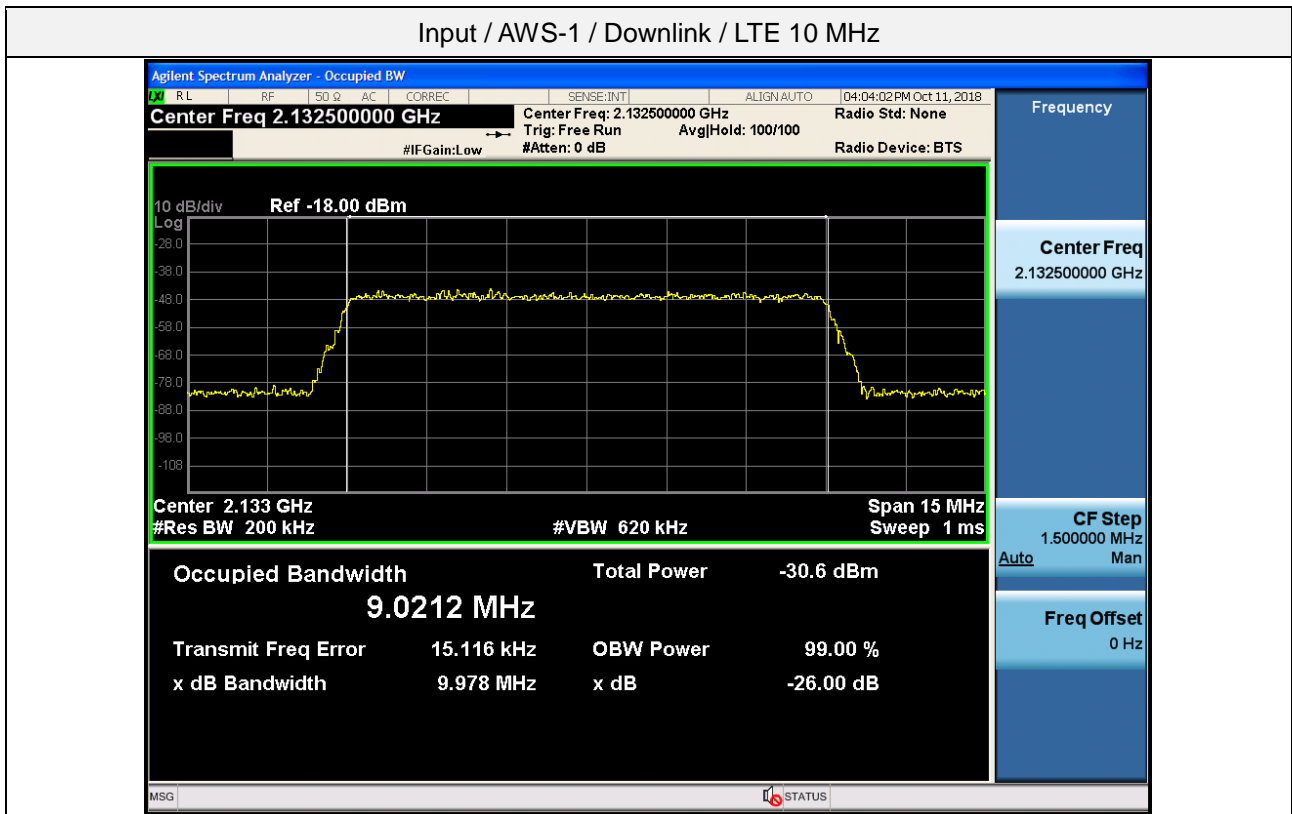
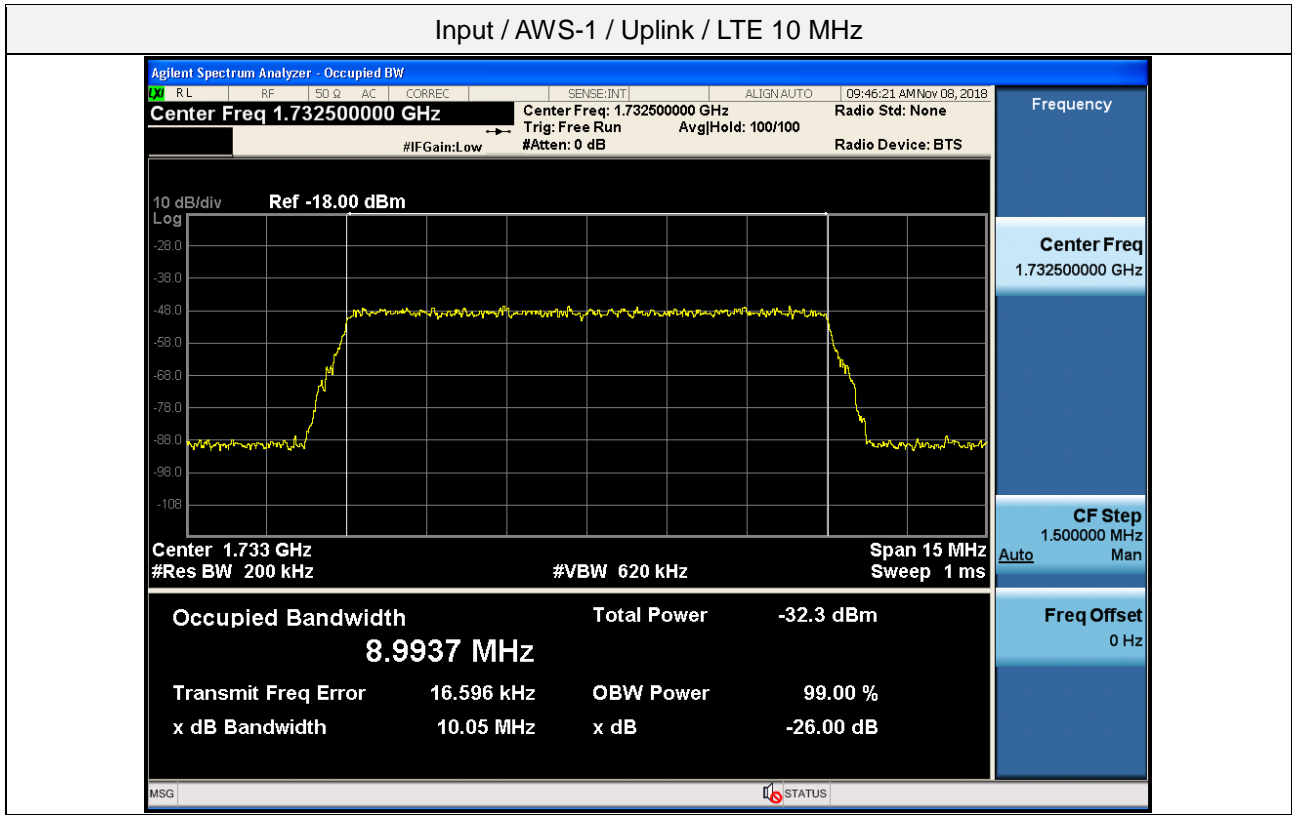

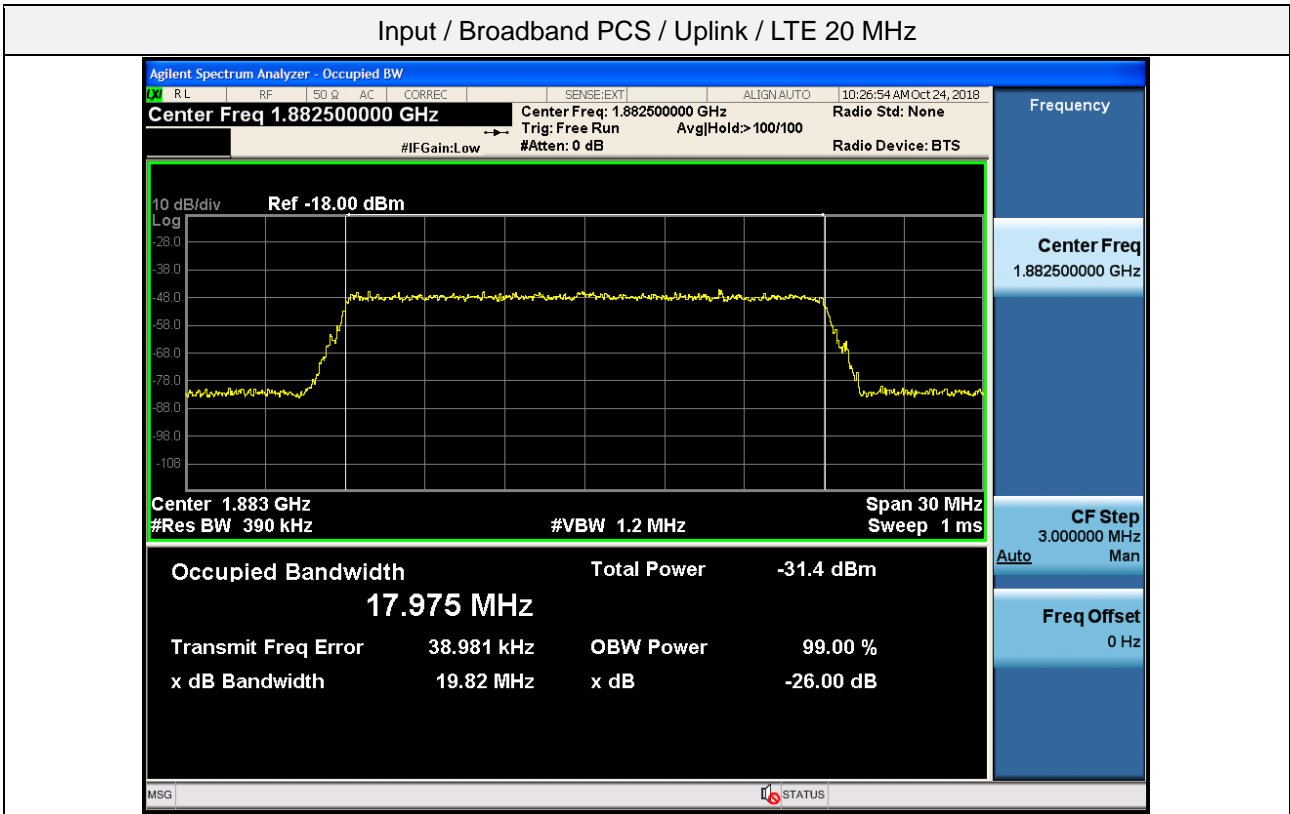
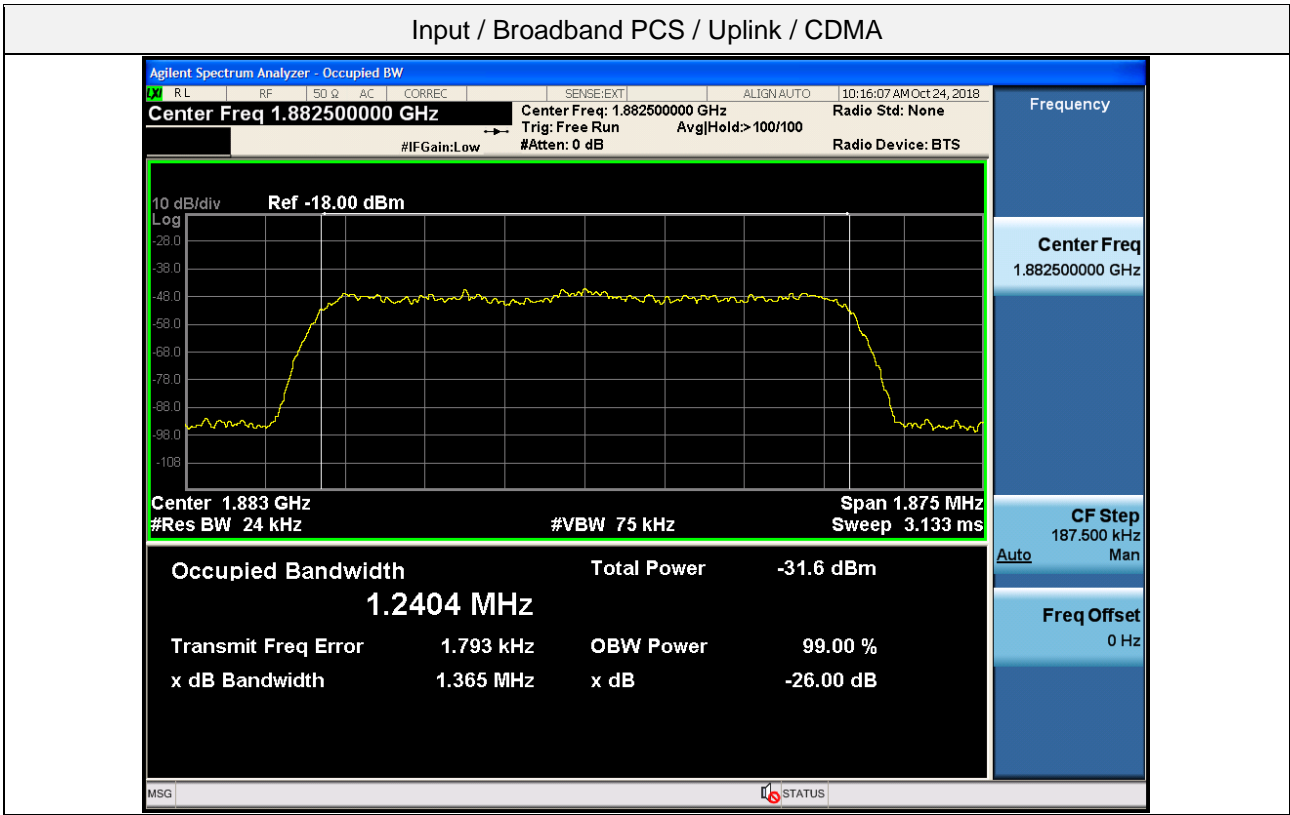

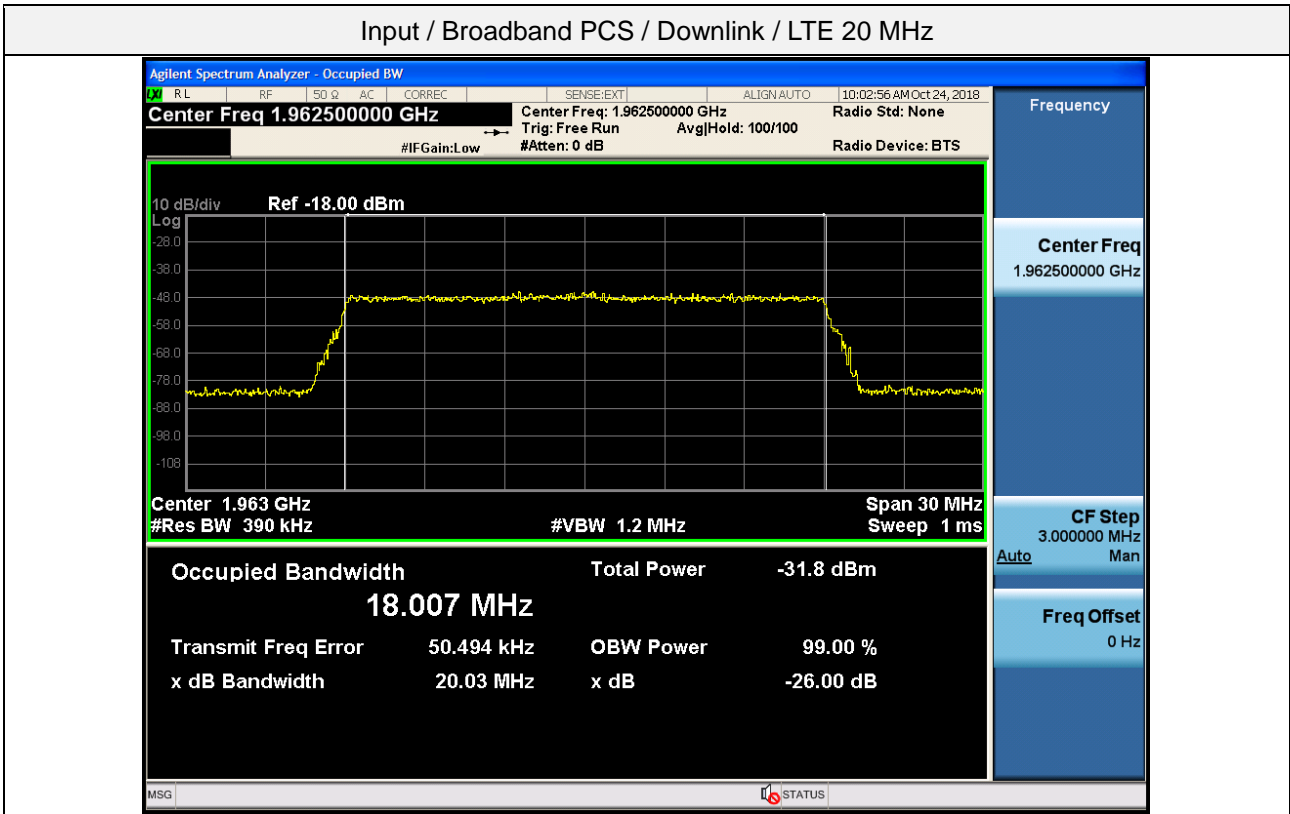
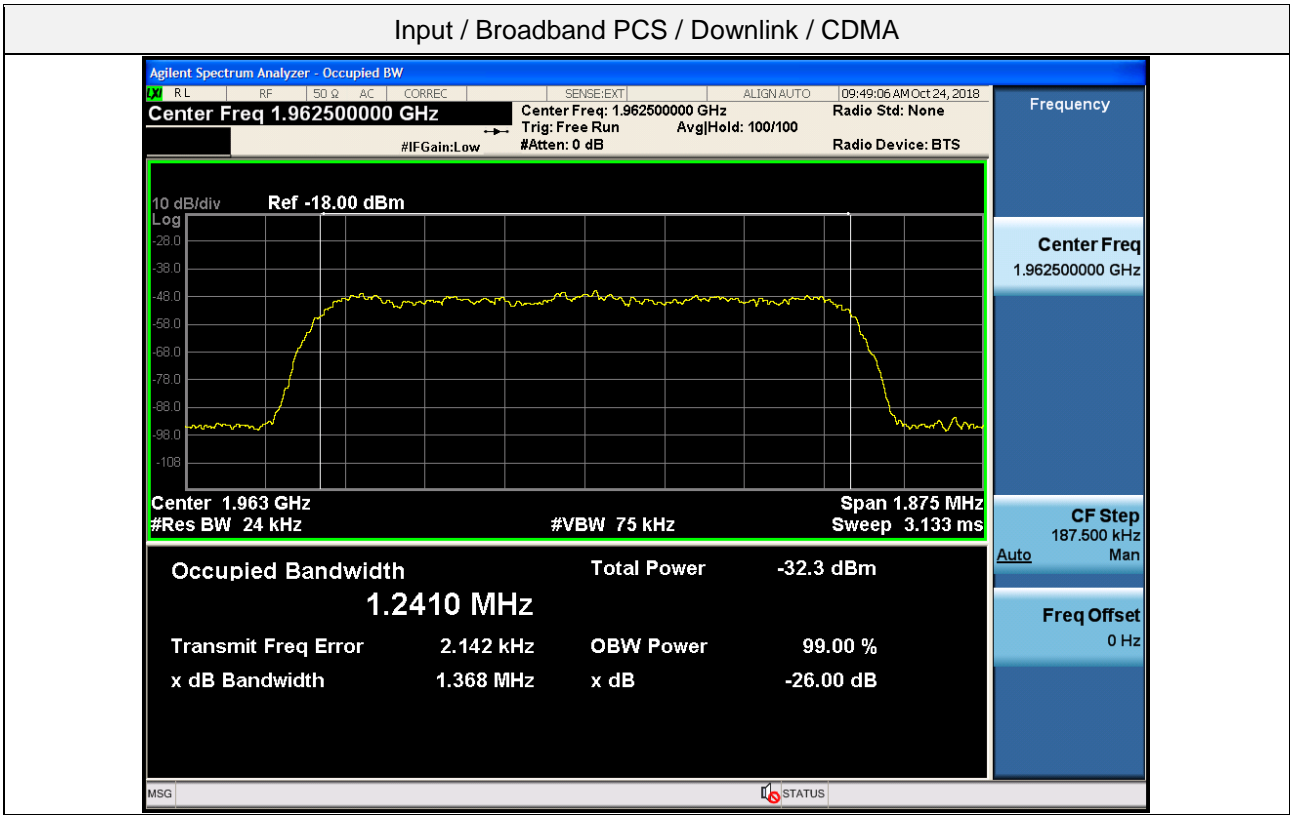

3 dB above the AGC threshold output / Lower 700 MHz / Uplink / LTE 10 MHz

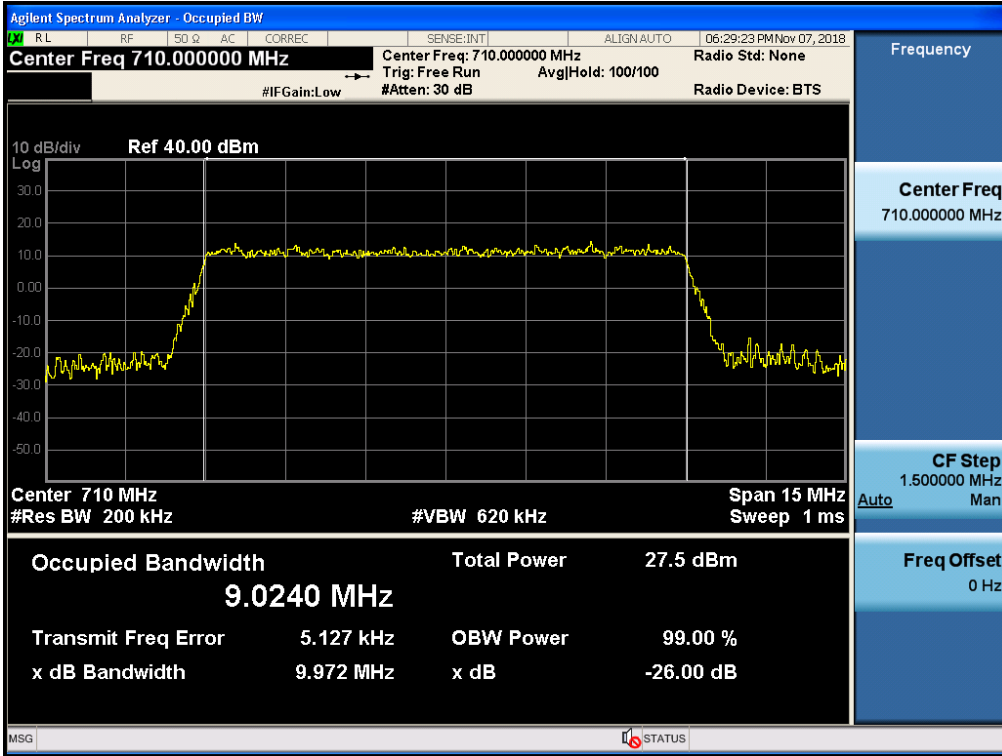

3 dB above the AGC threshold output / Lower 700 MHz / Downlink / LTE 10 MHz

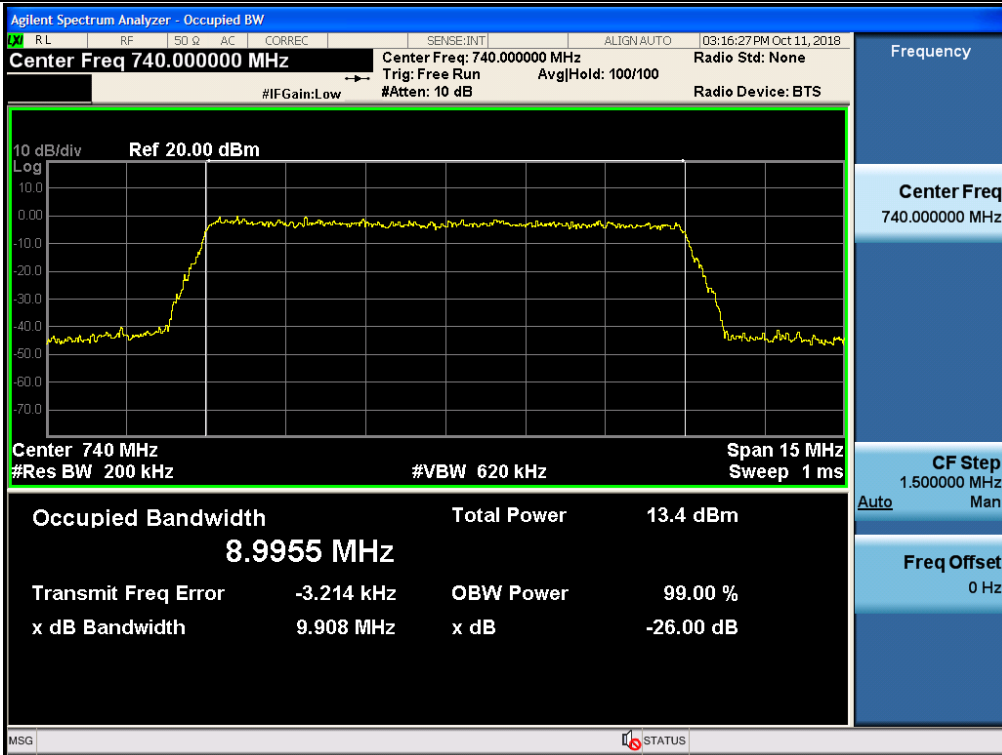



3 dB above the AGC threshold output / Upper 700 MHz / Uplink / LTE 10 MHz

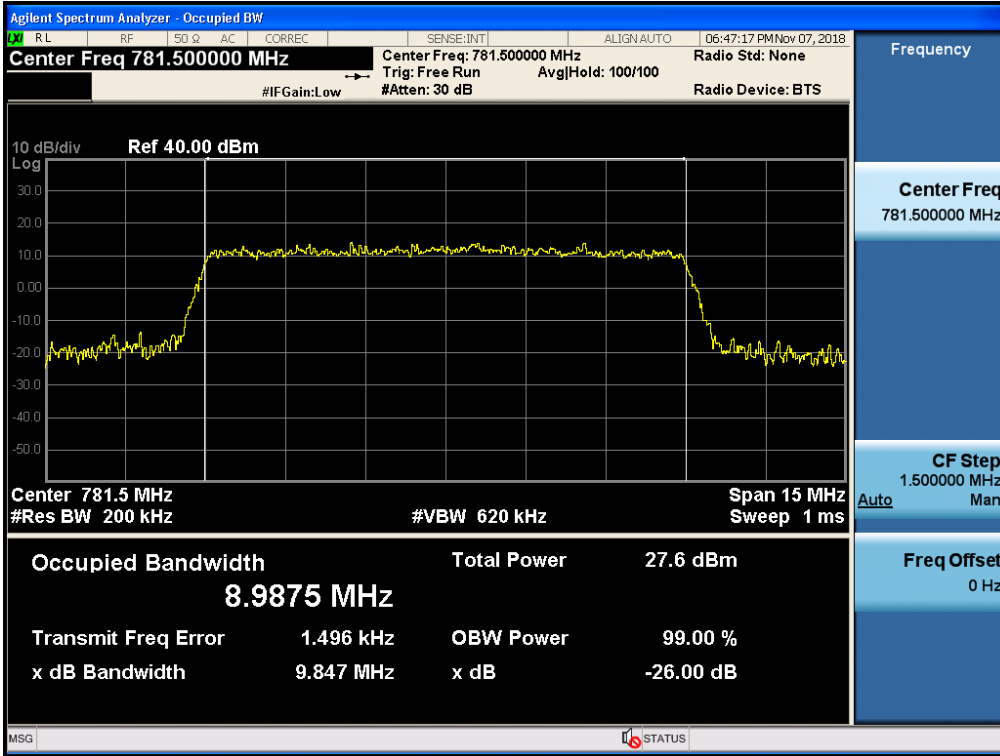

3 dB above the AGC threshold output / Upper 700 MHz / Downlink / LTE 10 MHz

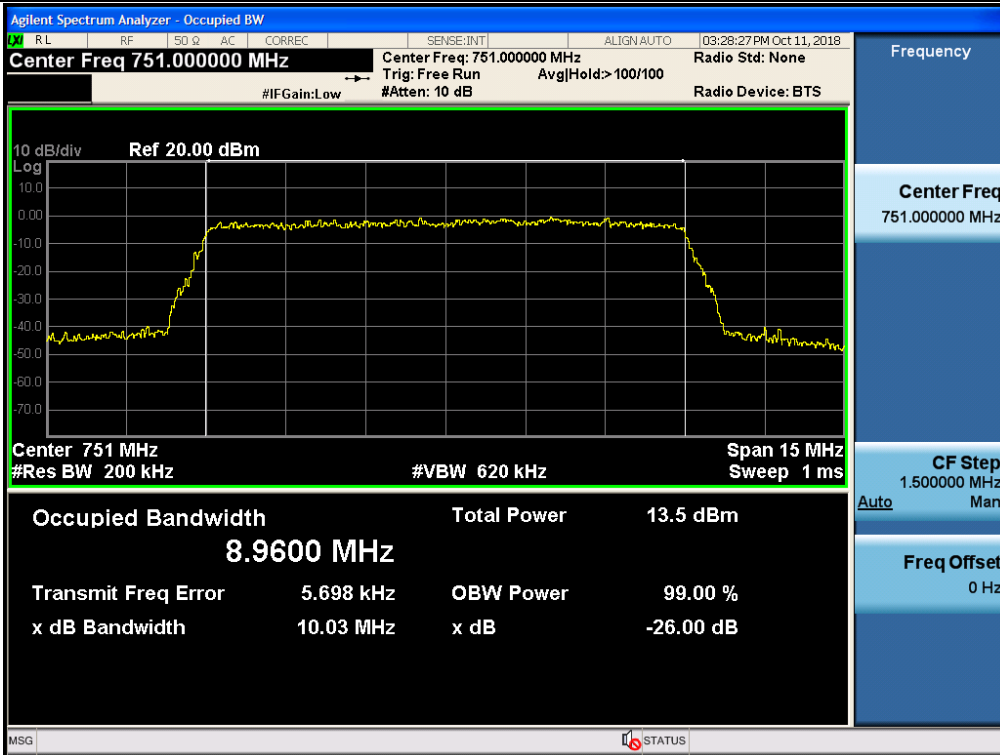

3 dB above the AGC threshold output / Cellular / Uplink / CDMA

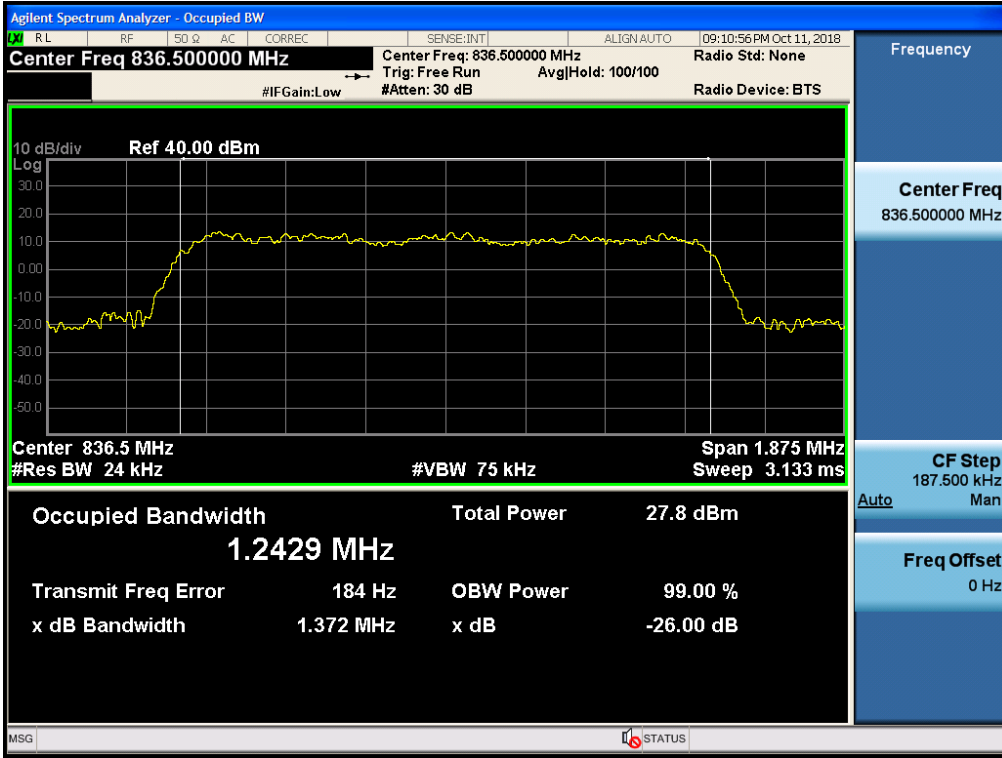

3 dB above the AGC threshold output / Cellular / Uplink / LTE 5 MHz

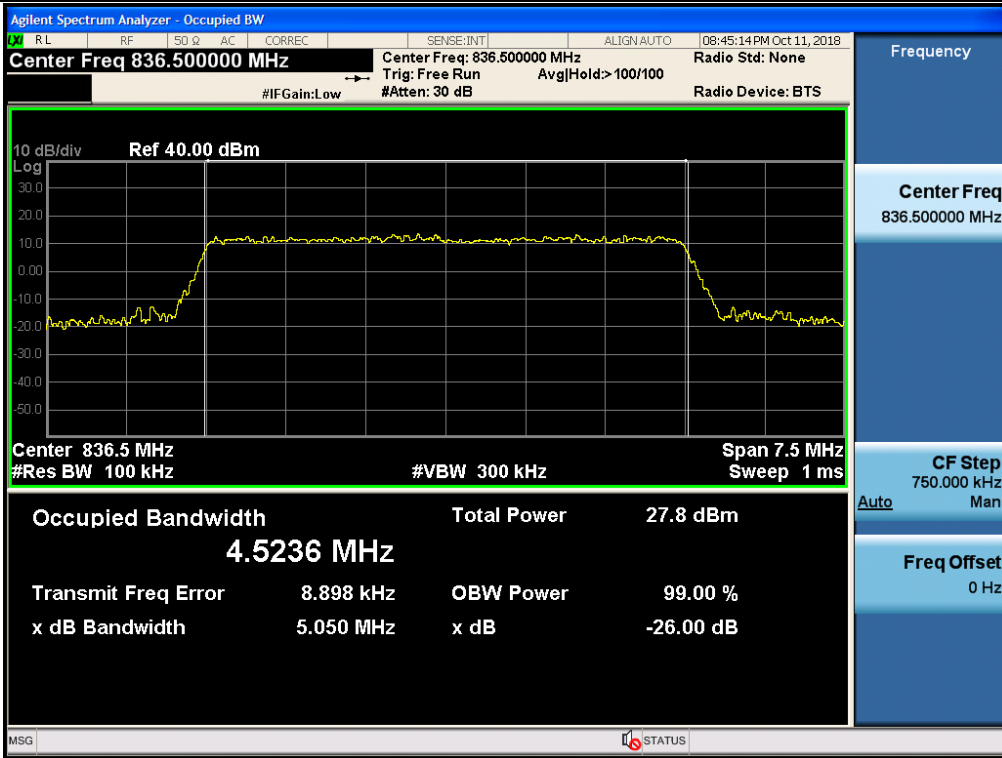

3 dB above the AGC threshold output / Cellular / Downlink / CDMA

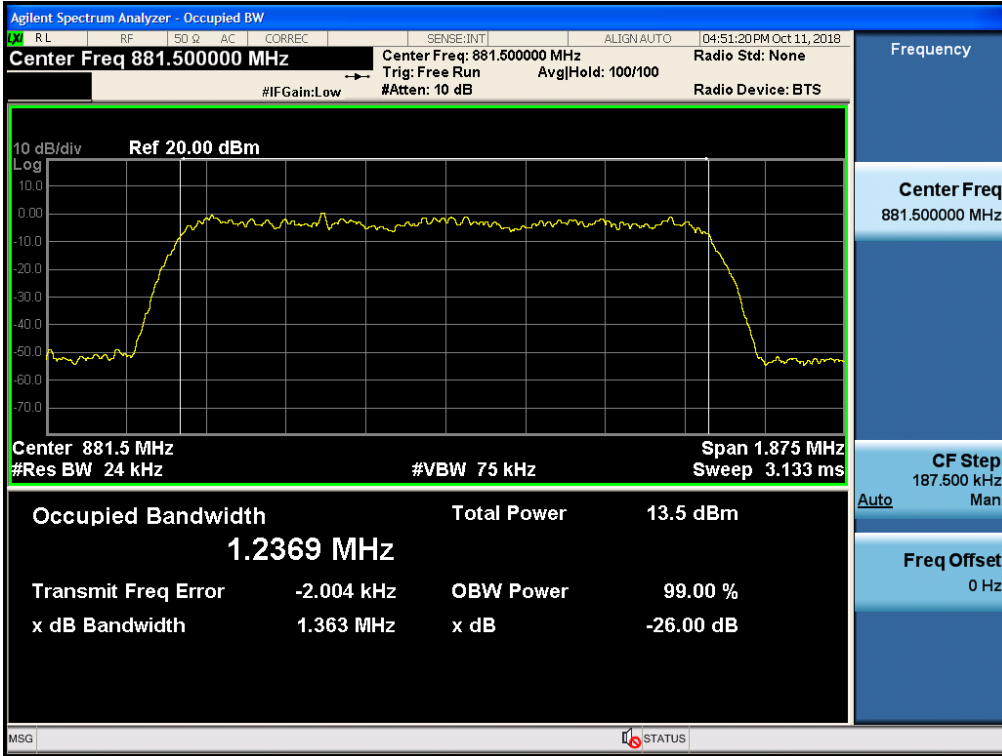

3 dB above the AGC threshold output / Cellular / Downlink / LTE 5 MHz

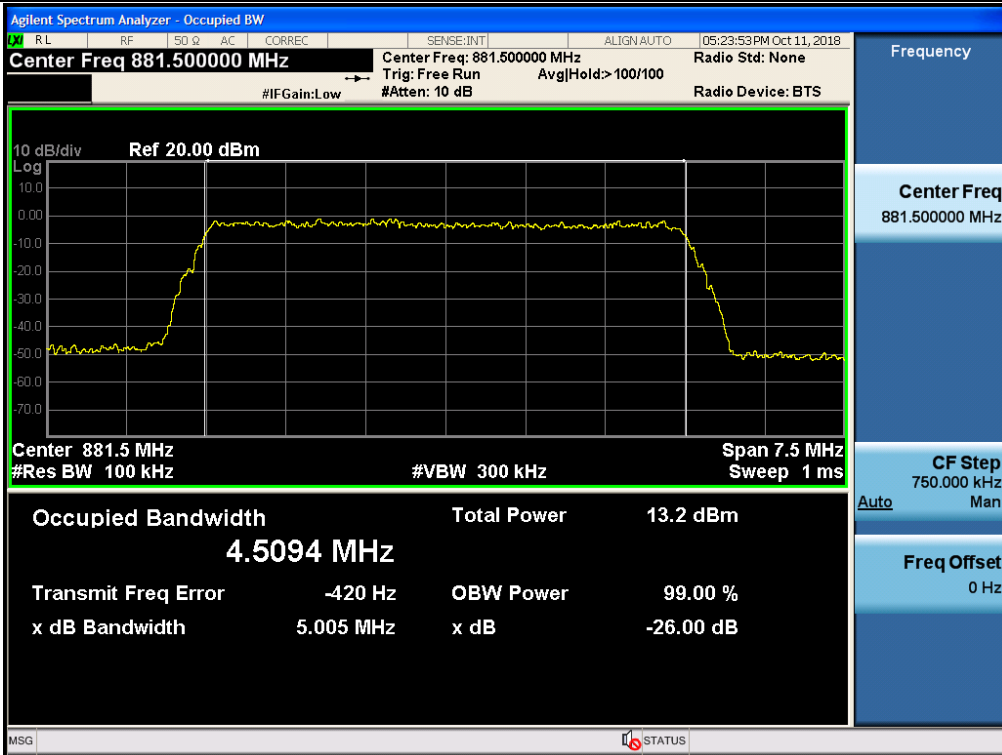

3 dB above the AGC threshold output / AWS-1 / Uplink / LTE 10 MHz

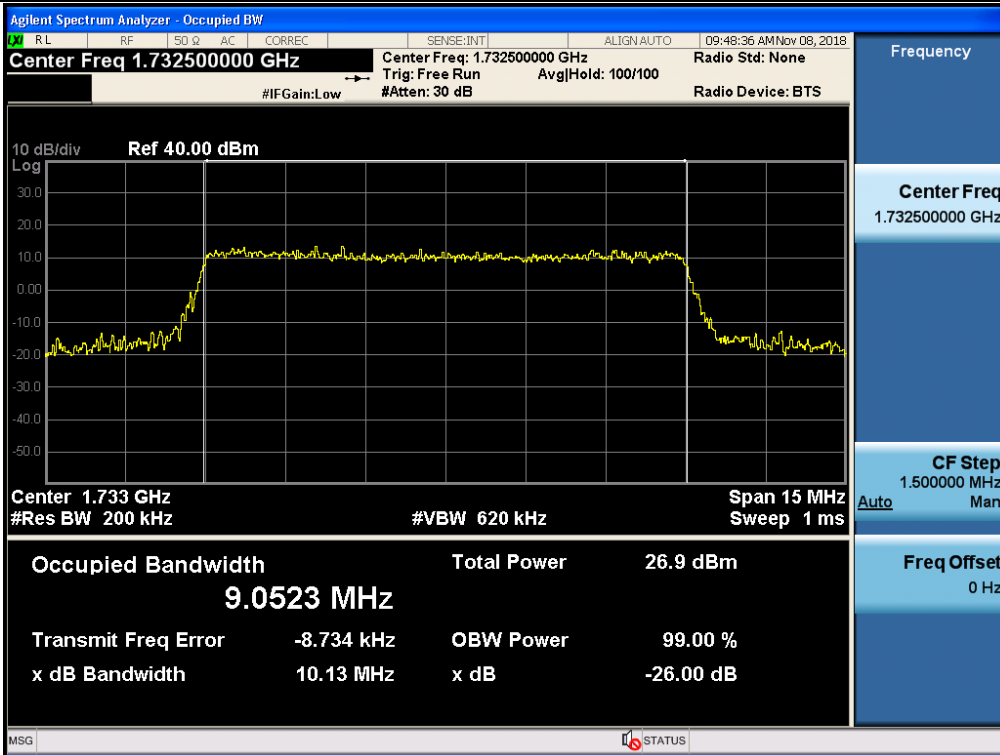

3 dB above the AGC threshold output / AWS-1 / Downlink / LTE 10 MHz

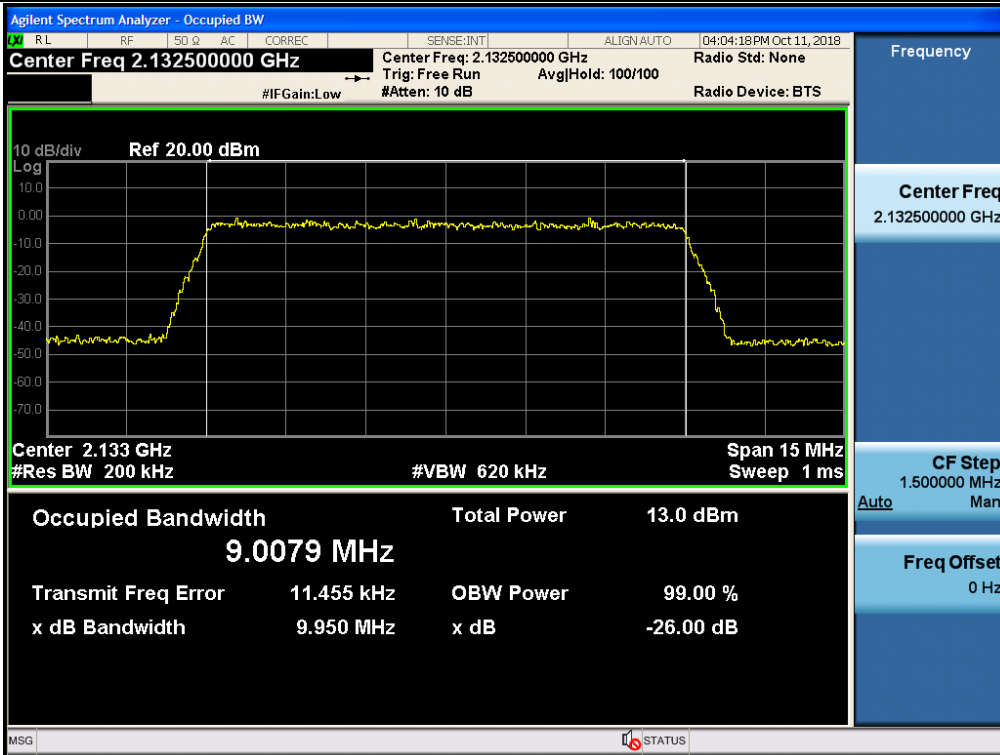

3 dB above the AGC threshold output / Broadband PCS / Uplink / CDMA

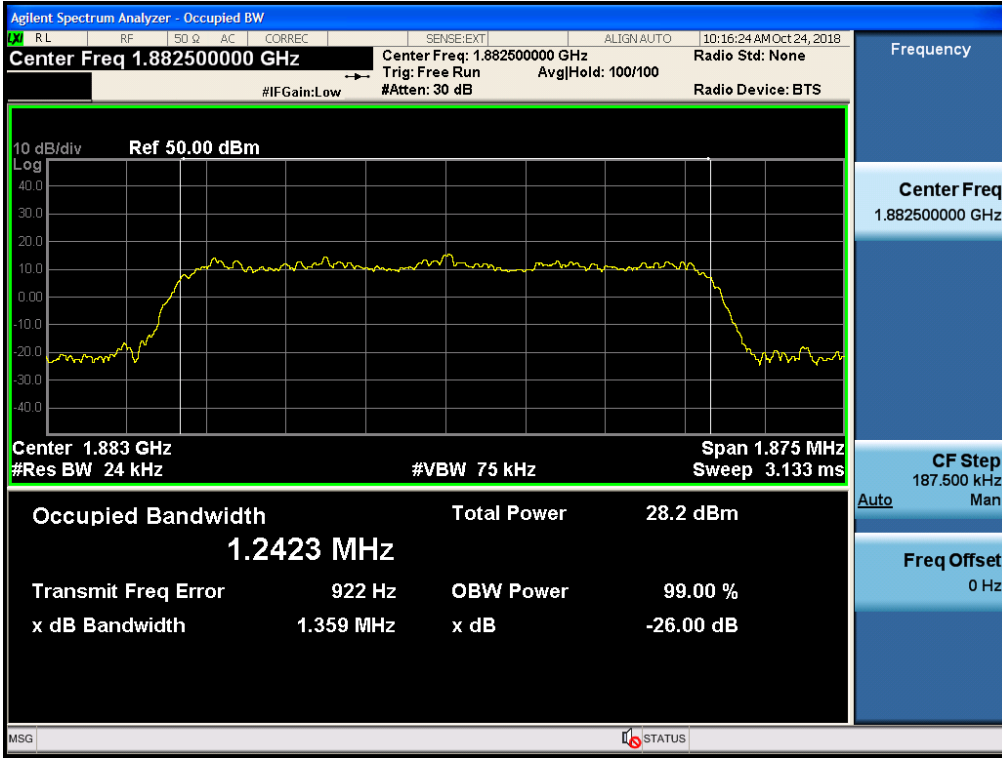

3 dB above the AGC threshold output / Broadband PCS / Uplink / LTE 20 MHz

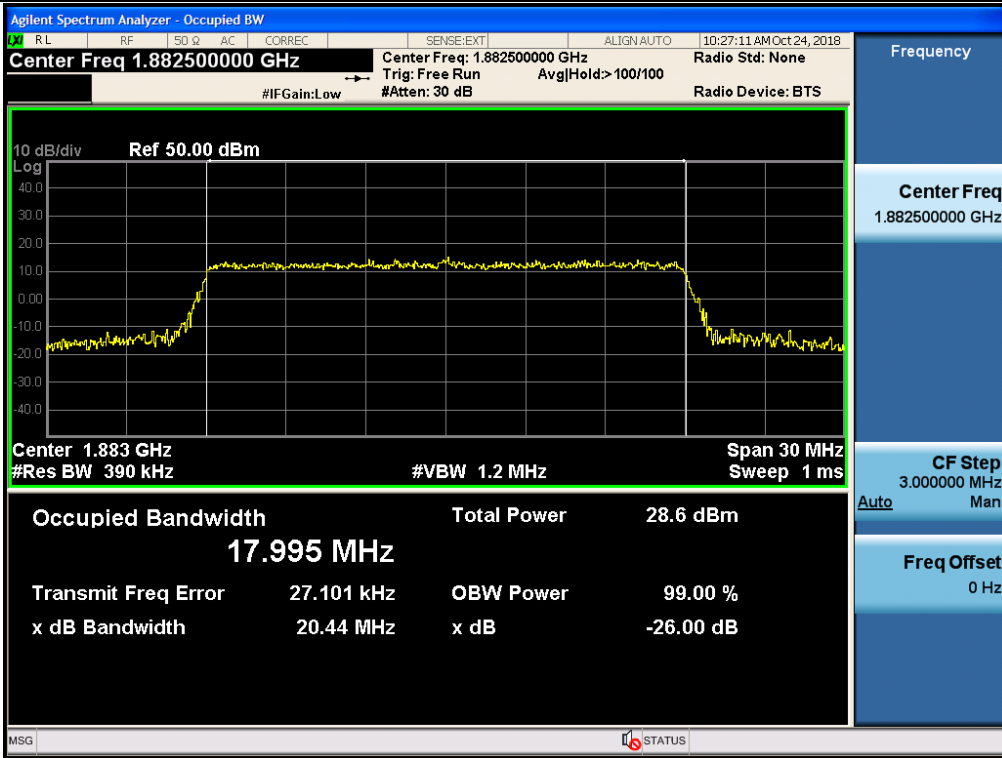

3 dB above the AGC threshold output / Broadband PCS / Downlink / CDMA

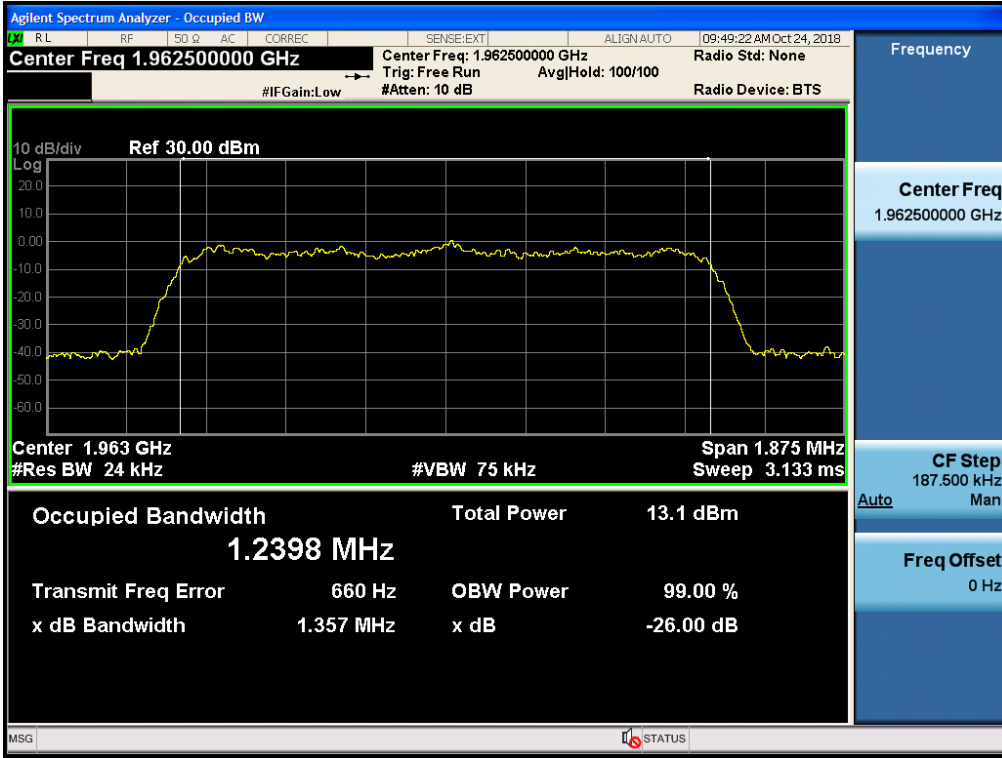

3 dB above the AGC threshold output / Broadband PCS / Downlink / LTE 20 MHz

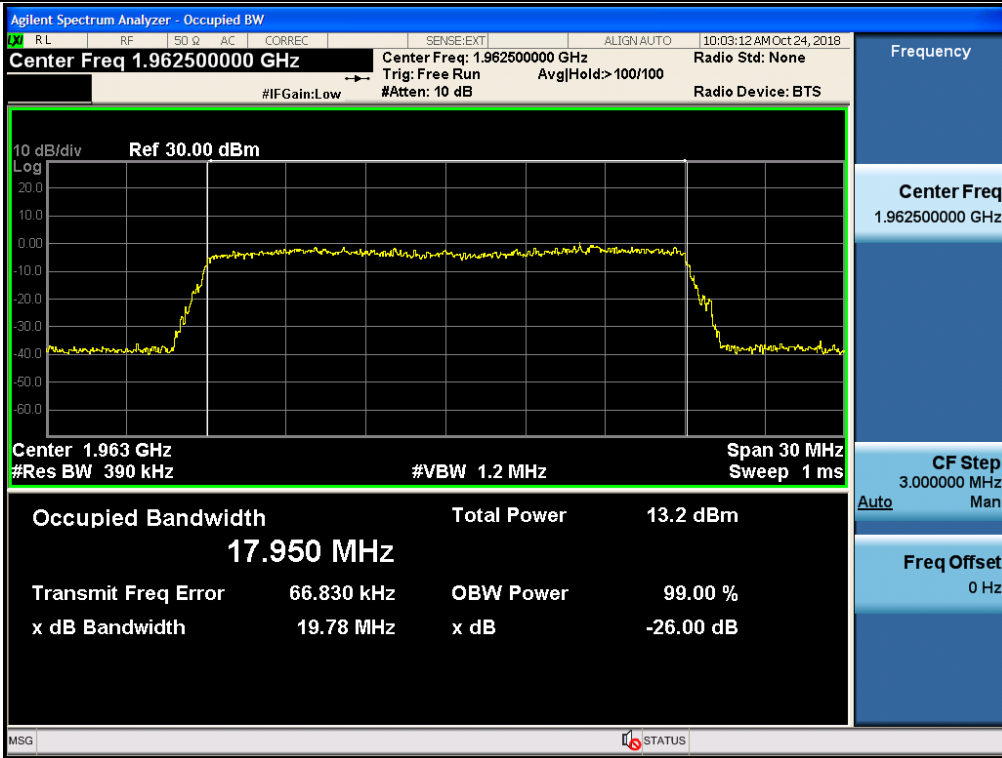

## 5.4. MEAN OUTPUT POWER AND AMPLIFIER/BOOSTER GAIN

### Test Requirement:

#### §2.1046 Measurements required: RF power output.

(a) For transmitters other than single sideband, independent sideband and controlled carrier radiotelephone, power output shall be measured at the RF output terminals when the transmitter is adjusted in accordance with the tune-up procedure to give the values of current and voltage on the circuit elements specified in §2.1033(c)(8). The electrical characteristics of the radio frequency load attached to the output terminals when this test is made shall be stated.

(b) For single sideband, independent sideband, and single channel, controlled carrier radiotelephone transmitters the procedure specified in paragraph (a) of this section shall be employed and, in addition, the transmitter shall be modulated during the test as specified and applicable in § 2.1046 (b) (1-5). In all tests, the input level of the modulating signal shall be such as to develop rated peak envelope power or carrier power, as appropriate, for the transmitter.

(c) For measurements conducted pursuant to paragraphs (a) and (b) of this section, all calculations and methods used by the applicant for determining carrier power or peak envelope power, as appropriate, on the basis of measured power in the radio frequency load attached to the transmitter output terminals shall be shown. Under the test conditions specified, no components of the emission spectrum shall exceed the limits specified in the applicable rule parts as necessary for meeting occupied bandwidth or emission limitations.

#### §22.913 Effective radiated power limits.

Licensees in the Cellular Radiotelephone Service are subject to the effective radiated power (ERP) limits and other requirements in this Section. See also §22.169.

(a) *Maximum ERP.* The ERP of transmitters in the Cellular Radiotelephone Service must not exceed the limits in this section.

(1) Except as described in paragraphs (a)(2), (3), and (4) of this section, the ERP of base stations and repeaters must not exceed—

- (i) 500 watts per emission; or
- (ii) 400 watts/MHz (PSD) per sector.

(d) Power measurement. Measurement of the ERP of Cellular base transmitters and repeaters must be made using an average power measurement technique. The peak-to-average ratio (PAR) of the transmission must not exceed 13 dB. Power measurements for base transmitters and repeaters must be made in accordance with either of the following:

- (1) A Commission-approved average power technique (see FCC Laboratory's Knowledge Database); or
- (2) For purposes of this section, peak transmit power must be measured over an interval of continuous transmission using instrumentation calibrated in terms of an rms-equivalent voltage. The measurement results shall be properly adjusted for any instrument limitations, such as detector response times, limited

resolution bandwidth capability when compared to the emission bandwidth, sensitivity, etc., so as to obtain a true peak measurement for the emission in question over the full bandwidth of the channel.

**§24.232 Power and antenna height limits.**

(2) Base stations with an emission bandwidth greater than 1 MHz are limited to 1640 watts/MHz equivalent isotropically radiated power (EIRP) with an antenna height up to 300 meters HAAT, except as described in paragraph (b) below.

(3) Base station antenna heights may exceed 300 meters HAAT with a corresponding reduction in power; see Tables 2 of this section.

Table 2—Reduced Power for Base Station Antenna Heights Over 300 Meters, With Emission Bandwidth Greater Than 1 MHz

HAAT in meters	Maximum EIRP (watts/MHz)
≤300	1640
≤500	1070
≤1000	490
≤1500	270
≤2000	160

(2) Base stations that are located in counties with population densities of 100 persons or fewer per square mile, based upon the most recently available population statistics from the Bureau of the Census, with an emission bandwidth greater than 1 MHz are limited to 3280 watts/MHz equivalent isotropically radiated power (EIRP) with an antenna height up to 300 meters HAAT.

(3) Base station antenna heights may exceed 300 meters HAAT with a corresponding reduction in power; see Tables 4 of this section.

Table 4—Reduced Power for Base Station Antenna Heights Over 300 Meters, With Emission Bandwidth Greater Than 1 MHz

HAAT in meters	Maximum EIRP (watts/MHz)
≤300	3280
≤500	2140
≤1000	980
≤1500	540
≤2000	320

(d) Power measurements for transmissions by stations authorized under this section may be made either in accordance with a Commission-approved average power technique or in compliance with paragraph (e) of this section. In both instances, equipment employed must be authorized in accordance with the provisions of §24.51. In measuring transmissions in this band using an average power technique, the peak-to-average ratio (PAR) of the transmission may not exceed 13 dB.

(e) Peak transmit power must be measured over any interval of continuous transmission using instrumentation calibrated in terms of an rms-equivalent voltage. The measurement results shall be properly adjusted for any instrument limitations, such as detector response times, limited resolution bandwidth capability when compared to the emission bandwidth, sensitivity, etc., so as to obtain a true peak measurement for the emission in question over the full bandwidth of the channel.



**§27.50 Power limits and duty cycle.**

(b) The following power and antenna height limits apply to transmitters operating in the 746-758 MHz, 775-788 MHz and 805-806 MHz bands:

(4) Fixed and base stations transmitting a signal in the 746-757 MHz and 776-787 MHz bands with an emission bandwidth greater than 1 MHz must not exceed an ERP of 1000 watts/MHz and an antenna height of 305 m HAAT, except that antenna heights greater than 305 m HAAT are permitted if power levels are reduced below 1000 watts/MHz ERP in accordance with Table 3 of this section.

(5) Fixed and base stations located in a county with population density of 100 or fewer persons per square mile, based upon the most recently available population statistics from the Bureau of the Census, and transmitting a signal in the 746-757 MHz and 776-787 MHz bands with an emission bandwidth greater than 1 MHz must not exceed an ERP of 2000 watts/MHz and an antenna height of 305 m HAAT, except that antenna heights greater than 305 m HAAT are permitted if power levels are reduced below 2000 watts/MHz ERP in accordance with Table 4 of this section.

(c) The following power and antenna height requirements apply to stations transmitting in the 600 MHz band and the 698-746 MHz band:

(4) Fixed and base stations located in a county with population density of 100 or fewer persons per square mile, based upon the most recently available population statistics from the Bureau of the Census, and transmitting a signal with an emission bandwidth greater than 1 MHz must not exceed an ERP of 2000 watts/MHz and an antenna height of 305 m HAAT, except that antenna heights greater than 305 m HAAT are permitted if power levels are reduced below 2000 watts/MHz ERP in accordance with Table 4 of this section;

(5) Licensees, except for licensees operating in the 600 MHz downlink band, seeking to operate a fixed or base station located in a county with population density of 100 or fewer persons per square mile, based upon the most recently available population statistics from the Bureau of the Census, and transmitting a signal at an ERP greater than 1000 watts must:

(i) Coordinate in advance with all licensees authorized to operate in the 698-758 MHz, 775-788, and 805-806 MHz bands within 120 kilometers (75 miles) of the base or fixed station;

(ii) coordinate in advance with all regional planning committees, as identified in §90.527 of this chapter, with jurisdiction within 120 kilometers (75 miles) of the base or fixed station.

(d) The following power and antenna height requirements apply to stations transmitting in the 1695-1710 MHz, 1710-1755 MHz, 1755-1780 MHz, 1915-1920 MHz, 1995-2000 MHz, 2000-2020 MHz, 2110-2155 MHz, 2155-2180 MHz and 2180-2200 MHz bands:

(1) The power of each fixed or base station transmitting in the 1995-2000 MHz, 2110-2155 MHz, 2155-2180 MHz or 2180-2200 MHz band and located in any county with population density of 100 or fewer persons per square mile, based upon the most recently available population statistics from the Bureau of the Census, is limited to:

(i) An equivalent isotropically radiated power (EIRP) of 3280 watts when transmitting with an emission bandwidth of 1 MHz or less;

- (ii) An EIRP of 3280 watts/MHz when transmitting with an emission bandwidth greater than 1 MHz.
- (2) The power of each fixed or base station transmitting in the 1995-2000 MHz, the 2110-2155 MHz 2155-2180 MHz band, or 2180-2200 MHz band and situated in any geographic location other than that described in paragraph (d)(1) of this section is limited to:
- (i) An equivalent isotropically radiated power (EIRP) of 1640 watts when transmitting with an emission bandwidth of 1 MHz or less;
  - (ii) An EIRP of 1640 watts/MHz when transmitting with an emission bandwidth greater than 1 MHz.
- (3) A licensee operating a base or fixed station in the 2110-2155 MHz band utilizing a power greater than 1640 watts EIRP and greater than 1640 watts/MHz EIRP must coordinate such operations in advance with all Government and non-Government satellite entities in the 2025-2110 MHz band. A licensee operating a base or fixed station in the 2110-2180 MHz band utilizing power greater than 1640 watts EIRP and greater than 1640 watts/MHz EIRP must be coordinated in advance with the following licensees authorized to operate within 120 kilometers (75 miles) of the base or fixed station operating in this band: All Broadband Radio Service (BRS) licensees authorized under this part in the 2155-2160 MHz band and all advanced wireless services (AWS) licensees authorized to operate on adjacent frequency blocks in the 2110-2180 MHz band.
- (5) Equipment employed must be authorized in accordance with the provisions of §24.51. Power measurements for transmissions by stations authorized under this section may be made either in accordance with a Commission-approved average power technique or in compliance with paragraph (d)(6) of this section. In measuring transmissions in this band using an average power technique, the peak-to-average ratio (PAR) of the transmission may not exceed 13 dB.
- (6) Peak transmit power must be measured over any interval of continuous transmission using instrumentation calibrated in terms of an rms-equivalent voltage. The measurement results shall be properly adjusted for any instrument limitations, such as detector response times, limited resolution bandwidth capability when compared to the emission bandwidth, sensitivity, etc., so as to obtain a true peak measurement for the emission in question over the full bandwidth of the channel.

**Test Procedures:**

Measurements were in accordance with the test methods section 3.5 of KDB 935210 D05 v01r02.

*Adjust the internal gain control of the EUT to the maximum gain for which the equipment certification is being sought. Any EUT attenuation settings shall be set to their minimum value.*

*Input power levels (uplink and downlink) should be set to maximum input ratings while confirming that the device is not capable of operating in saturation (non-linear mode) at the rated input levels, including during the performance of the input/output power measurements.*

**3.5.2 Measuring the EUT mean input and output power**

- a) Connect a signal generator to the input of the EUT.
- b) Configure to generate the test signal.

- c) The frequency of the signal generator shall be set to the frequency  $f_0$  as determined from out-of-band rejection test.
- d) Connect a spectrum analyzer or power meter to the output of the EUT using appropriate attenuation as necessary.
- e) Set the signal generator output power to a level that produces an EUT output level that is just below the AGC threshold, but not more than 0.5 dB below.
- f) Measure and record the output power of the EUT; use ANSI C63.26-2015 subclause 5.2.4.4.1, for power measurement.
- g) Remove the EUT from the measurement setup. Using the same signal generator settings, repeat the power measurement at the signal generator port, which was used as the input signal to the EUT, and record as the input power. EUT gain may be calculated as described in 3.5.5.
- h) Repeat steps f) and g) with input signal amplitude set to 3 dB above the AGC threshold level.
- i) Repeat steps e) to h) with the narrowband test signal.
- j) Repeat steps e) to i) for all frequency bands authorized for use by the EUT.

### 3.5.5 Calculating amplifier, repeater, or industrial booster gain

After the input and output power levels have been measured as described in the preceding subclauses, the gain of the EUT can be determined from:

$$\text{Gain (dB)} = \text{output power (dBm)} - \text{input power (dBm)}.$$

Report the gain for each authorized operating frequency band, and each test signal stimulus.

**Note1.** If  $f_0$  that determined from out-of-band test is smaller or greater than difference of test signal's center frequency and operation band block, test is performed at the lowest or the highest frequency that test signals can be passed.

**Test Results:**

**Tabular data of Input / Output Power and Gain**

Test Band	Link	Signal	f <sub>0</sub> Frequency (MHz)	Input Power (dBm)	Output Power (dBm)	Gain (dB)
Lower 700 MHz	Uplink	LTE 10 MHz	709.00	-39.95	19.72	59.67
	Downlink	LTE 10 MHz	739.00	-54.72	4.77	59.49
Upper 700 MHz	Uplink	LTE 10 MHz	782.00	-39.84	19.78	59.62
	Downlink	LTE 10 MHz	751.00	-54.63	4.99	59.62
Cellular	Uplink	CDMA	831.06	-39.81	19.81	59.62
		LTE 5 MHz	831.06	-39.62	20.36	59.98
	Downlink	CDMA	873.88	-54.84	5.26	60.10
		LTE 5 MHz	873.88	-54.68	4.80	59.48
AWS-1	Uplink	LTE 10 MHz	1 725.53	-44.90	19.73	64.63
	Downlink	LTE 10 MHz	2 124.40	-58.45	5.17	63.62
Broadband PCS	Uplink	CDMA	1 888.84	-45.13	19.69	64.82
		LTE 20 MHz	1 888.84	-45.29	19.53	64.82
	Downlink	CDMA	1 957.60	-57.96	5.39	63.35
		LTE 20 MHz	1 957.60	-57.60	4.85	62.45

**Tabular data of Input / 3 dB above AGC threshold Output Power and Gain**

Test Band	Link	Signal	f <sub>0</sub> Frequency (MHz)	Input Power (dBm)	+3 dB Output Power (dBm)	Gain (dB)
Lower 700 MHz	Uplink	LTE 10 MHz	709.00	-39.95	20.01	59.96
	Downlink	LTE 10 MHz	739.00	-54.72	4.93	59.65
Upper 700 MHz	Uplink	LTE 10 MHz	782.00	-39.84	19.80	59.64
	Downlink	LTE 10 MHz	751.00	-54.63	5.04	59.67
Cellular	Uplink	CDMA	831.06	-39.81	19.75	59.56
		LTE 5 MHz	831.06	-39.62	20.30	59.92
	Downlink	CDMA	873.88	-54.84	5.36	60.20
		LTE 5 MHz	873.88	-54.68	4.99	59.67
AWS-1	Uplink	LTE 10 MHz	1 725.53	-44.90	19.98	64.88
	Downlink	LTE 10 MHz	2 124.40	-58.45	5.28	63.73
Broadband PCS	Uplink	CDMA	1 888.84	-45.13	19.42	64.55
		LTE 20 MHz	1 888.84	-45.29	19.58	64.87
	Downlink	CDMA	1 957.60	-57.96	5.32	63.28
		LTE 20 MHz	1 957.60	-57.60	5.11	62.71

**Tabular data of PAPR**

Test Band	Link	Signal	f <sub>0</sub> Frequency (MHz)	0.1 % PAPR (dB)
Cellular	Uplink	CDMA	831.06	7.54
		LTE 5 MHz	831.06	7.63
	Downlink	CDMA	873.88	7.84
		LTE 5 MHz	873.88	8.27
AWS-1	Uplink	LTE 10 MHz	1 725.53	6.38
	Downlink	LTE 10 MHz	2 124.40	8.30
Broadband PCS	Uplink	CDMA	1 888.84	6.68
		LTE 20 MHz	1 888.84	7.68
	Downlink	CDMA	1 957.60	7.68
		LTE 20 MHz	1 957.60	8.33

Plot data of PAPR

