



RADIO TEST REPORT

Test Report No. : 12046146H-A

Applicant : **Panasonic Avionics Corporation**
Type of Equipment : **BTv4.0 Dual Mode USB HCI Module**
Model No. : **R8U4FD3830Z**
FCC ID : **U6YBT800**
Test regulation : **FCC Part 15 Subpart C: 2018**
Class II Permissive Change
*** Bluetooth Low Energy part**
(Radiated Spurious Emission test only)
Test Result : **Complied**

1. This test report shall not be reproduced in full or partial, without the written approval of UL Japan, Inc.
2. The results in this report apply only to the sample tested.
3. This sample tested is in compliance with the above regulation.
4. The test results in this report are traceable to the national or international standards.
5. This test report must not be used by the customer to claim product certification, approval, or endorsement by NVLAP, NIST, or any agency of the Federal Government.
6. This test report covers Radio technical requirements. It does not cover administrative issues such as Manual or non-Radio test related Requirements. (if applicable)

Date of test: November 29 and December 1, 2017

Representative test engineer:

T. Shimada
Takumi Shimada
Engineer
Consumer Technology Division

Approved by:

Takayuki S
Takayuki Shimada
Leader
Consumer Technology Division

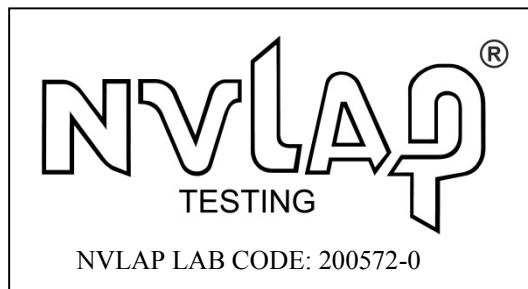

This laboratory is accredited by the NVLAP LAB CODE 200572-0, U.S.A. The tests reported herein have been performed in accordance with its terms of accreditation.
*As for the range of Accreditation in NVLAP, you may refer to the WEB address,
http://japan.ul.com/resources/emc_accredited/

UL Japan, Inc.

Ise EMC Lab.

4383-326 Asama-cho, Ise-shi, Mie-ken 516-0021 JAPAN

Telephone : +81 596 24 8999

Facsimile : +81 596 24 8124

13-EM-F0429

REVISION HISTORY

Original Test Report No.: 12046146H-A

Revision	Test report No.	Date	Page revised	Contents
- (Original)	12046146H-A	January 31, 2018	-	-

CONTENTS	PAGE
SECTION 1: Customer information.....	4
SECTION 2: Equipment under test (E.U.T.).....	4
SECTION 3: Test specification, procedures & results.....	5
SECTION 4: Operation of E.U.T. during testing.....	8
SECTION 5: Radiated Spurious Emission	10
APPENDIX 1: Test data	12
Radiated Spurious Emission	13
APPENDIX 2: Test instruments	19
APPENDIX 3: Photographs of test setup	20
Radiated Spurious Emission	20
Worst Case Position	21

SECTION 1: Customer information

Company Name : Panasonic Avionics Corporation
Address : 26200 Enterprise Way Lake Forest, CA 92630 USA
Telephone Number : +1-949-672-2000
Facsimile Number : +1-949-462-7100
Contact Person : David O'Reilly

SECTION 2: Equipment under test (E.U.T.)

2.1 Identification of E.U.T.

Type of Equipment : BTv4.0 Dual Mode USB HCI Module
Model No. : R8U4FD3830Z
Serial No. : Refer to Section 4, Clause 4.2
Rating : DC 5 V
Receipt Date of Sample : November 16, 2017
Country of Mass-production : Japan
Condition of EUT : Production prototype
(Not for Sale: This sample is equivalent to mass-produced items.)
Modification of EUT : No Modification by the test lab

2.2 Product Description

Model: R8U4FD3830Z (referred to as the EUT in this report) is a BTv4.0 Dual Mode USB HCI Module.

Radio Specification

[Bluetooth (Ver.4.0 Dual mode (Classic Bluetooth and BLE))]

Radio Type : Transceiver
Frequency of Operation : 2402 MHz - 2480 MHz
Modulation : BT: FHSS (GFSK, $\pi/4$ DQPSK, 8DPSK)
LE: GFSK
Channel spacing : BT: 1 MHz
LE: 2 MHz
Power Supply (radio part input) : DC 3.3 V / DC 1.8 V
Antenna type : Microstrip Antenna
Antenna Gain : 0.4 dBi
Clock frequency (Maximum) : 48 MHz

*This test report applies to Bluetooth Ver.4.0 with EDR function (LE part: 2402 MHz - 2480 MHz).

<Contents of the change from original model>

Antenna of the EUT was modified and antenna gain is larger than original model.

The radio specification is identical to the original.

Therefore only Radiated Spurious Emission test were performed in this report.

Additionally, only the information of modified antenna is described in this report.

UL Japan, Inc.

Ise EMC Lab.

4383-326 Asama-cho, Ise-shi, Mie-ken 516-0021 JAPAN

Telephone : +81 596 24 8999

Facsimile : +81 596 24 8124

SECTION 3: Test specification, procedures & results

3.1 Test Specification

Test Specification : FCC Part 15 Subpart C
FCC Part 15 final revised on January 2, 2018 and effective February 1, 2018

Title : FCC 47CFR Part15 Radio Frequency Device Subpart C Intentional Radiators
Section 15.207 Conducted limits
Section 15.247 Operation within the bands 902-928MHz,
2400-2483.5MHz, and 5725-5850MHz

* The revision on January 2, 2018, does not affect the test specification applied to the EUT.

3.2 Procedures and results

Item	Test Procedure	Specification	Worst margin	Results	Remarks
Spurious Emission Restricted Band Edges	FCC: KDB 558074 D01 DTS Meas Guidance v04 IC: RSS-Gen 6.13	FCC: Section15.247(d) IC: RSS-247 5.5 RSS-Gen 8.9 RSS-Gen 8.10	3.3 dB 41.232 MHz, QP, Vert.	Complied	Radiated (above 30 MHz) *1)
Note: UL Japan, Inc.'s EMI Work Procedures No. 13-EM-W0420 and 13-EM-W0422.					
*1) Radiated test was selected over 30 MHz based on section 15.247(d) and KDB 558074 D01 DTS Meas Guidance v04 12.2.7.					

* In case any questions arise about test procedure, ANSI C63.10: 2013 is also referred.

FCC Part 15.31 (e)

This EUT provides stable voltage (DC 3.3 V) constantly to RF Module regardless of input voltage. Therefore, this EUT complies with the requirement.

FCC Part 15.203 Antenna requirement

The antenna is not removable from the EUT.
Therefore, the equipment complies with the antenna requirement of Section 15.203.

3.3 Addition to standard

No addition, exclusion nor deviation has been made from the standard.

3.4 Uncertainty

EMI

The following uncertainties have been calculated to provide a confidence level of 95 % using a coverage factor $k=2$.

Ise EMC Lab.

Radiated emission

Measurement distance	Frequency range	Uncertainty (+/-)
3 m	9 kHz to 30 MHz	3.3 dB
10 m		3.2 dB
3 m	30 MHz to 200 MHz (Horizontal) (Vertical)	4.8 dB
		5.0 dB
	200 MHz to 1000 MHz (Horizontal) (Vertical)	5.2 dB
		6.3 dB
10 m	30 MHz to 200 MHz (Horizontal) (Vertical)	4.8 dB
		4.9 dB
	200 MHz to 1000 MHz (Horizontal) (Vertical)	5.0 dB
		5.0 dB
3 m	1 GHz to 6 GHz	5.0 dB
	6 GHz to 18 GHz	5.3 dB
1 m	10 GHz to 26.5 GHz	5.8 dB
	26.5 GHz to 40 GHz	5.8 dB
10 m	1 GHz to 18 GHz	5.2 dB

Radiated emission test

The data listed in this report meets the limits unless the uncertainty is taken into consideration.

3.5 Test Location

UL Japan, Inc. Ise EMC Lab.
4383-326 Asama-cho, Ise-shi, Mie-ken 516-0021 JAPAN
Telephone: +81 596 24 8999, Facsimile: +81 596 24 8124
NVLAP Lab. code: 200572-0 / FCC Test Firm Registration Number: 199967

Test site	IC Registration Number	Width x Depth x Height (m)	Size of reference ground plane (m) / horizontal conducting plane	Other rooms	Maximum measurement distance
No.1 semi-anechoic chamber	2973C-1	19.2 x 11.2 x 7.7	7.0 x 6.0	No.1 Power source room	10 m
No.2 semi-anechoic chamber	2973C-2	7.5 x 5.8 x 5.2	4.0 x 4.0	-	3 m
No.3 semi-anechoic chamber	2973C-3	12.0 x 8.5 x 5.9	6.8 x 5.75	No.3 Preparation room	3 m
No.3 shielded room	-	4.0 x 6.0 x 2.7	N/A	-	-
No.4 semi-anechoic chamber	2973C-4	12.0 x 8.5 x 5.9	6.8 x 5.75	No.4 Preparation room	3 m
No.4 shielded room	-	4.0 x 6.0 x 2.7	N/A	-	-
No.5 semi-anechoic chamber	-	6.0 x 6.0 x 3.9	6.0 x 6.0	-	-
No.6 shielded room	-	4.0 x 4.5 x 2.7	4.0 x 4.5	-	-
No.6 measurement room	-	4.75 x 5.4 x 3.0	4.75 x 4.15	-	-
No.7 shielded room	-	4.7 x 7.5 x 2.7	4.7 x 7.5	-	-
No.8 measurement room	-	3.1 x 5.0 x 2.7	N/A	-	-
No.9 measurement room	-	8.8 x 4.6 x 2.8	2.4 x 2.4	-	-
No.11 measurement room	-	6.2 x 4.7 x 3.0	4.8 x 4.6	-	-

* Size of vertical conducting plane (for Conducted Emission test) : 2.0 m x 2.0m for No.1, No.2, No.3, and No.4 semi-anechoic chambers and No.3 and No.4 shielded rooms.

3.6 Test data, Test instruments, and Test set up

Refer to APPENDIX.

SECTION 4: Operation of E.U.T. during testing

4.1 Operating Mode(s)

Test operating mode was determined as follows according to “Section 1 of 6 802.11 a/b/g/n testing - Managing Complex Regulatory Approvals - ” of TCB Council Workshop October 2009.

Mode	Remarks*
Bluetooth Low Energy (BT LE)	Maximum Packet Size, PRBS9
*The worst condition was determined based on the test result of Maximum Peak Output Power (Mid Channel)	
*Power of the EUT was set by the software as follows; Power settings: : -8 dBm Software: pactest	
*This setting of software is the worst case. Any conditions under the normal use do not exceed the condition of setting. In addition, end users cannot change the settings of the output power of the product.	

*The details of Operating mode(s) for BT LE

Test Item	Operating Mode	Tested frequency
Radiated Spurious Emission (Below 1GHz/ Above 1GHz)	Tx BT LE	2402 MHz 2440 MHz 2480 MHz

Configuration and peripherals

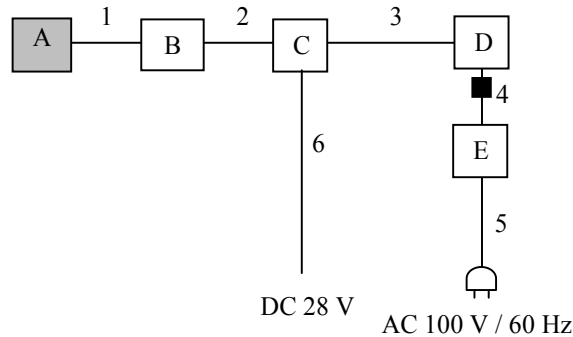

■ : Standard Ferrite Core

* Cabling and setup(s) were taken into consideration and test data was taken under worse case conditions.

Description of EUT and Support equipment

No.	Item	Model number	Serial number	Manufacturer	Remarks
A	Bluetooth BTv4.0 Dual Mode USB HCI Module	R8U4FD3830Z	F16120345	Panasonic Corporation	EUT
B	Monitor	FD-2824-U1	024	Panasonic Corporation	-
C	SEAT ELECTRONICS BOX	RD-FA3124-03	G905997	Panasonic Corporation	-
D	Laptop PC	CF-74	8BKSA00538	Panasonic Corporation	-
E	AC adaptor	CF-AA5803A	5803AM108400359A	Panasonic Corporation	-

List of cables used

No.	Name	Length (m)	Shield		Remarks
			Cable	Connector	
1	Signal Cable	1.75	Shielded	Shielded	-
2	Signal Cable	6.00	Shielded	Shielded	-
3	LAN Cable	1.00	Shielded	Shielded	-
4	DC Cable	2.00	Unshielded	Unshielded	-
5	AC Cable	1.80	Unshielded	Unshielded	-
6	AC Cable	2.00	Unshielded	Unshielded	-

UL Japan, Inc.

Ise EMC Lab.

4383-326 Asama-cho, Ise-shi, Mie-ken 516-0021 JAPAN

Telephone : +81 596 24 8999

Facsimile : +81 596 24 8124

SECTION 5: Radiated Spurious Emission

Test Procedure

It was measured based on "11.0 Emissions in non-restricted frequency bands" of "KDB 558074 D01 DTS Meas Guidance v04".

[For below 1 GHz]

EUT was placed on a urethane platform of nominal size, 0.5 m by 1.0 m, raised 0.8 m above the conducting ground plane. The Radiated Electric Field Strength has been measured in a Semi Anechoic Chamber with a ground plane.

[For above 1 GHz]

EUT was placed on a urethane platform of nominal size, 0.5 m by 0.5 m, raised 1.5 m above the conducting ground plane.

The Radiated Electric Field Strength has been measured in a Semi Anechoic Chamber with absorbent materials lined on a ground plane.

The height of the measuring antenna varied between 1 and 4 m and EUT was rotated a full revolution in order to obtain the maximum value of the electric field strength.

The measurements were performed for both vertical and horizontal antenna polarization with the Test Receiver, or the Spectrum Analyzer.

The measurements were made with the following detector function of the test receiver and the Spectrum analyzer (in linear mode).

The test was made with the detector (RBW/VBW) in the following table.

When using Spectrum analyzer, the test was made with adjusting span to zero by using peak hold.

Test Antennas are used as below;

Frequency	30 MHz to 200 MHz	200 MHz to 1 GHz	Above 1 GHz
Antenna Type	Biconical	Logperiodic	Horn

In any 100 kHz bandwidth outside the restricted band in which the spread spectrum intentional radiator is operating, the radio frequency power that is produced by the intentional radiator confirmed 20 dB below that in the 100 kHz bandwidth within the band that contains the highest level of the desired power, based on a radiated measurement.

20 dBc was applied to the frequency over the limit of FCC 15.209 / Table 4 of RSS-Gen 8.9(IC) and outside the restricted band of FCC15.205 / Table 6 of RSS-Gen 8.10 (IC).

Frequency	Below 1 GHz	Above 1 GHz		20 dBc
Instrument used	Test Receiver	Spectrum Analyzer		Spectrum Analyzer
Detector	QP	PK	AV *1)	PK
IF Bandwidth	BW 120 kHz	RBW: 1 MHz VBW: 3 MHz	Average Power Method: RBW: 1 MHz VBW: 3 MHz Detector: Power Averaging (RMS) Trace: 100 traces If duty cycle was less than 98%, a duty factor was added to the results.	RBW: 100 kHz VBW: 300kHz
Test Distance	3 m	4 m *2) (1 GHz – 10 GHz), 1 m *3) (10 GHz – 26.5 GHz)		4 m *2) (1 GHz – 10 GHz), 1 m *3) (10 GHz – 26.5 GHz)

*1) Average Power Measurement was performed based on 6.0 & 12.2.5 of "KDB 558074 D01 DTS Meas Guidance v04".

*2) Distance Factor: $20 \times \log(4.0 \text{ m} / 3.0 \text{ m}) = 2.5 \text{ dB}$

*3) Distance Factor: $20 \times \log(1.0 \text{ m} / 3.0 \text{ m}) = -9.5 \text{ dB}$

- The carrier level and noise levels were confirmed at each position of X, Y and Z axes of EUT to see the position of maximum noise, and the test was made at the position that has the maximum noise.

The test results and limit are rounded off to one decimal place, so some differences might be observed.

Measurement range : 30 MHz - 26.5 GHz
Test data : APPENDIX
Test result : Pass

APPENDIX 1: Test data

Burst rate confirmation

Test place	Ise EMC Lab. No.3 Semi Anechoic Chamber
Report No.	12046146H
Date	November 29, 2017
Temperature / Humidity	23 deg. C / 41 % RH
Engineer	Takumi Shimada
Mode	Tx

BT LE

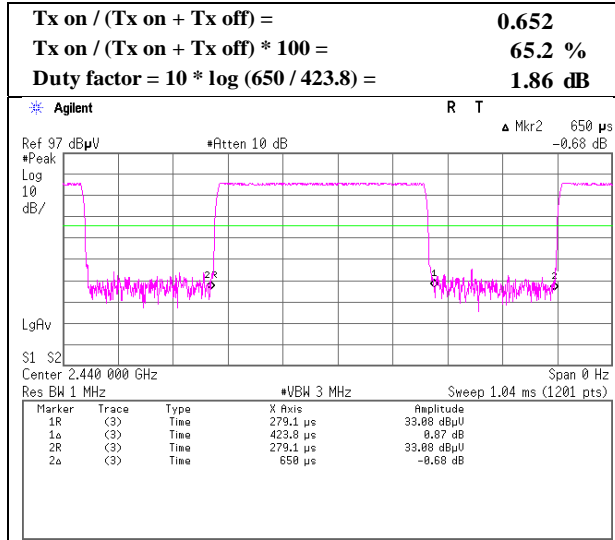

* Since the burst rate is not different between the channels, the data has been obtained on the representative channel.

Radiated Spurious Emission

Report No. 12046146H
Test place Ise EMC Lab.
Semi Anechoic Chamber No.3 No.3
Date November 29, 2017 December 1, 2017
Temperature / Humidity 23 deg. C / 41 % RH 22 deg. C / 33 % RH
Engineer Takumi Shimada Takumi Shimada
(Above 1 GHz) (Below 1 GHz)
Mode Tx BT LE 2402 MHz

Polarity	Frequency [MHz]	Detector	Reading [dBuV]	Ant.Fac. [dB/m]	Loss [dB]	Gain [dB]	Duty Factor [dB]	Result [dBuV/m]	Limit [dBuV/m]	Margin [dB]	Remark
Hori	56.758	QP	37.3	8.4	7.6	32.2	-	21.1	40.0	18.9	
Hori	77.213	QP	39.0	6.5	7.9	32.2	-	21.2	40.0	18.8	
Hori	123.399	QP	36.2	13.0	8.5	32.2	-	25.5	43.5	18.0	
Hori	212.264	QP	46.5	11.6	9.3	32.1	-	35.3	43.5	8.2	
Hori	221.454	QP	45.8	11.6	9.4	32.1	-	34.7	46.0	11.3	
Hori	474.998	QP	34.6	17.2	11.2	32.0	-	31.0	46.0	15.0	
Hori	2390.000	PK	41.9	27.7	5.7	32.4	-	42.9	73.9	31.0	
Hori	4804.000	PK	43.4	31.6	8.0	31.4	-	51.6	73.9	22.3	
Hori	7206.000	PK	41.7	36.0	9.4	32.1	-	55.0	73.9	18.9	Floor noise
Hori	9608.000	PK	43.0	38.5	9.9	32.9	-	58.5	73.9	15.4	Floor noise
Hori	2390.000	AV	31.1	27.7	5.7	32.4	1.9	34.0	53.9	19.9	*1)
Hori	4804.000	AV	34.0	31.6	8.0	31.4	1.9	44.1	53.9	9.8	
Hori	7206.000	AV	32.0	36.0	9.4	32.1	-	45.3	53.9	8.6	Floor noise
Hori	9608.000	AV	31.0	38.5	9.9	32.9	-	46.5	53.9	7.4	Floor noise
Vert	41.255	QP	47.6	13.8	7.3	32.2	-	36.5	40.0	3.5	
Vert	58.256	QP	46.2	7.9	7.6	32.2	-	29.5	40.0	10.5	
Vert	123.447	QP	41.2	13.0	8.5	32.2	-	30.5	43.5	13.0	
Vert	207.748	QP	43.8	11.5	9.3	32.1	-	32.5	43.5	11.0	
Vert	222.597	QP	47.5	11.6	9.4	32.1	-	36.4	46.0	9.6	
Vert	474.984	QP	34.5	17.2	11.2	32.0	-	30.9	46.0	15.1	
Vert	2390.000	PK	42.0	27.7	5.7	32.4	-	43.0	73.9	30.9	
Vert	4804.000	PK	44.0	31.6	8.0	31.4	-	52.2	73.9	21.7	
Vert	7206.000	PK	43.1	36.0	9.4	32.1	-	56.4	73.9	17.5	Floor noise
Vert	9608.000	PK	41.0	38.5	9.9	32.9	-	56.5	73.9	17.4	Floor noise
Vert	2390.000	AV	31.0	27.7	5.7	32.4	1.9	33.9	53.9	20.0	*1)
Vert	4804.000	AV	34.2	31.6	8.0	31.4	1.9	44.3	53.9	9.6	
Vert	7206.000	AV	31.9	36.0	9.4	32.1	-	45.2	53.9	8.7	Floor noise
Vert	9608.000	AV	30.6	38.5	9.9	32.9	-	46.1	53.9	7.8	Floor noise

Result = Reading + Ant Factor + Loss (Cable+Attenuator+Filter+Distance factor(above 1 GHz)) - Gain(Amplifier) + Duty factor

*Other frequency noises omitted in this report were not seen or had enough margin (more than 20 dB).

Distance factor: 1 GHz - 10 GHz 20log (4 m / 3.0 m) = 2.5 dB
10 GHz - 26.5 GHz 20log (1.0 m / 3.0 m) = -9.5 dB

*1) Not Out of Band emission(Leakage Power)

20dBc Data Sheet

Polarity	Frequency [MHz]	Detector	Reading [dBuV]	Ant Factor [dB/m]	Loss [dB]	Gain [dB]	Result [dBuV/m]	Limit [dBuV/m]	Margin [dB]	Remark
Hori	2402.000	PK	79.1	27.7	5.8	32.4	80.2	-	-	Carrier
Hori	2400.000	PK	35.9	27.7	5.8	32.4	37.0	60.2	23.2	
Vert	2402.000	PK	79.1	27.7	5.8	32.4	80.2	-	-	Carrier
Vert	2400.000	PK	37.1	27.7	5.8	32.4	38.2	60.2	22.0	

Result = Reading + Ant Factor + Loss (Cable+Attenuator+Filter+Distance factor(above 1 GHz)) - Gain(Amplifier)

UL Japan, Inc.

Ise EMC Lab.

4383-326 Asama-cho, Ise-shi, Mie-ken 516-0021 JAPAN

Telephone : +81 596 24 8999

Facsimile : +81 596 24 8124

Radiated Spurious Emission
(Reference Plot for band-edge)

Report No. 12046146H
Test place Ise EMC Lab.
Semi Anechoic Chamber No.3
Date November 29, 2017
Temperature / Humidity 23 deg. C / 41 % RH
Engineer Takumi Shimada
(1 GHz - 10 GHz)
Mode Tx BT LE 2402 MHz

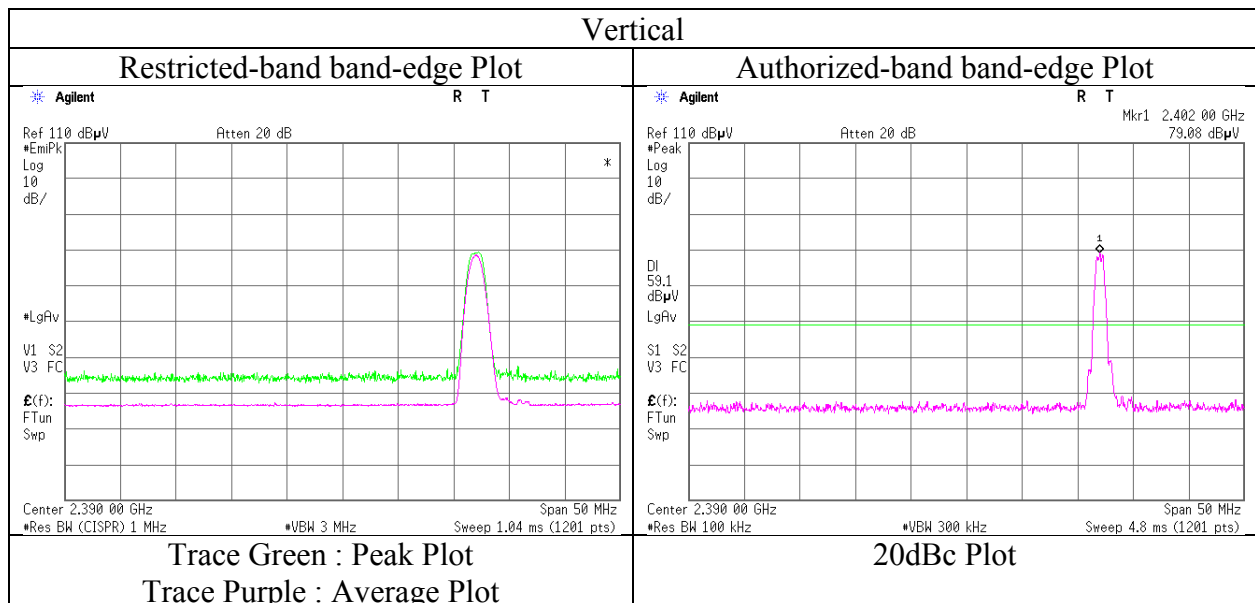
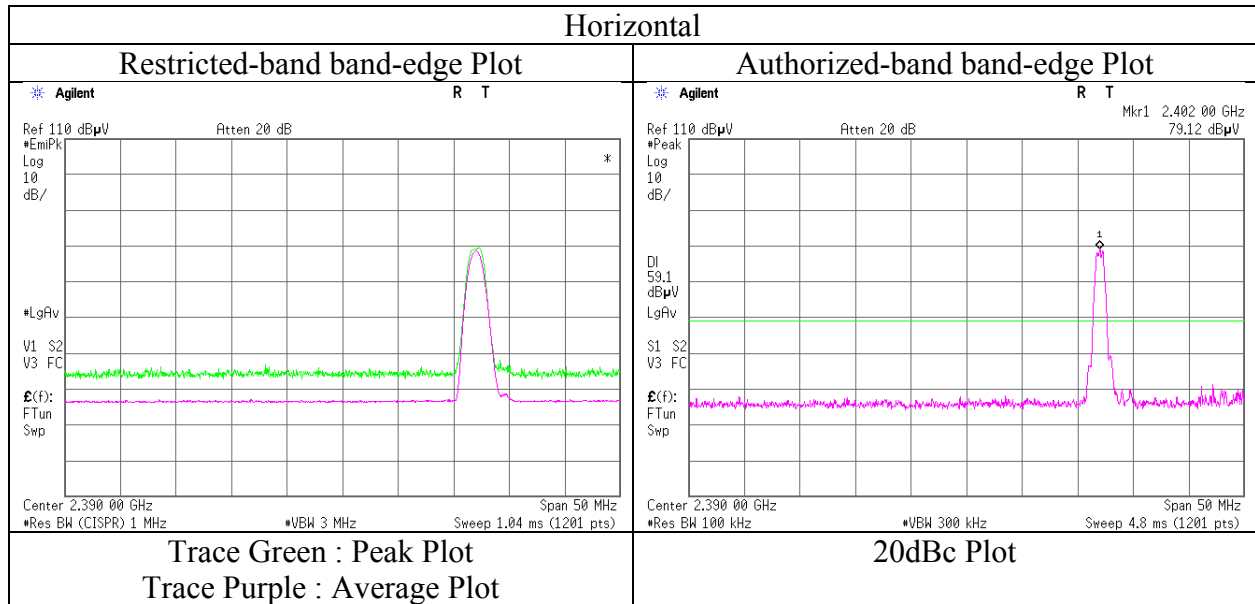

* Final result of restricted band edge was shown in tabular data.

Radiated Spurious Emission

Report No.	12046146H	
Test place	Ise EMC Lab.	
Semi Anechoic Chamber	No.3	No.3
Date	November 29, 2017	December 1, 2017
Temperature / Humidity	23 deg. C / 41 % RH	22 deg. C / 33 % RH
Engineer	Takumi Shimada	Takumi Shimada
	(Above 1 GHz)	(Below 1 GHz)
Mode	Tx BT LE 2440 MHz	

Polarity	Frequency [MHz]	Detector	Reading [dBuV]	Ant.Fac. [dB/m]	Loss [dB]	Gain [dB]	Duty Factor [dB]	Result [dBuV/m]	Limit [dBuV/m]	Margin [dB]	Remark
Hori	56.764	QP	37.1	8.4	7.6	32.2	-	20.9	40.0	19.1	
Hori	77.228	QP	38.6	6.5	7.9	32.2	-	20.8	40.0	19.2	
Hori	123.394	QP	36.7	13.0	8.5	32.2	-	26.0	43.5	17.5	
Hori	212.267	QP	47.7	11.6	9.3	32.1	-	36.5	43.5	7.0	
Hori	221.436	QP	46.0	11.6	9.4	32.1	-	34.9	46.0	11.1	
Hori	474.993	QP	34.8	17.2	11.2	32.0	-	31.2	46.0	14.8	
Hori	4880.000	PK	43.2	31.9	8.0	31.4	-	51.7	73.9	22.2	
Hori	7320.000	PK	39.4	36.2	9.4	32.2	-	52.8	73.9	21.1	Floor noise
Hori	9760.000	PK	40.2	38.7	10.0	33.0	-	55.9	73.9	18.0	Floor noise
Hori	4880.000	AV	35.6	31.9	8.0	31.4	1.9	46.0	53.9	7.9	
Hori	7320.000	AV	32.0	36.2	9.4	32.2	-	45.4	53.9	8.5	Floor noise
Hori	9760.000	AV	32.1	38.7	10.0	33.0	-	47.8	53.9	6.1	Floor noise
Vert	41.232	QP	47.8	13.8	7.3	32.2	-	36.7	40.0	3.3	
Vert	58.248	QP	46.4	7.9	7.6	32.2	-	29.7	40.0	10.3	
Vert	123.442	QP	41.4	13.0	8.5	32.2	-	30.7	43.5	12.8	
Vert	207.742	QP	44.1	11.5	9.3	32.1	-	32.8	43.5	10.7	
Vert	222.583	QP	47.2	11.6	9.4	32.1	-	36.1	46.0	9.9	
Vert	474.985	QP	34.3	17.2	11.2	32.0	-	30.7	46.0	15.3	
Vert	4880.000	PK	43.1	31.9	8.0	31.4	-	51.6	73.9	22.3	
Vert	7320.000	PK	40.4	36.2	9.4	32.2	-	53.8	73.9	20.1	Floor noise
Vert	9760.000	PK	41.5	38.7	10.0	33.0	-	57.2	73.9	16.7	Floor noise
Vert	4880.000	AV	35.7	31.9	8.0	31.4	1.9	46.1	53.9	7.8	
Vert	7320.000	AV	32.1	36.2	9.4	32.2	-	45.5	53.9	8.4	Floor noise
Vert	9760.000	AV	32.0	38.7	10.0	33.0	-	47.7	53.9	6.2	Floor noise

Result = Reading + Ant Factor + Loss (Cable+Attenuator+Filter+Distance factor(above 1 GHz)) - Gain(Amplifier) + Duty factor

*Other frequency noises omitted in this report were not seen or had enough margin (more than 20 dB).

Distance factor: 1 GHz - 10 GHz 20log (4 m / 3.0 m) = 2.5 dB
 10 GHz - 26.5 GHz 20log (1.0 m / 3.0 m) = -9.5 dB

Radiated Spurious Emission

Report No.	12046146H	
Test place	Ise EMC Lab.	
Semi Anechoic Chamber	No.3	No.3
Date	November 29, 2017	December 1, 2017
Temperature / Humidity	23 deg. C / 41 % RH	22 deg. C / 33 % RH
Engineer	Takumi Shimada	Takumi Shimada
	(Above 1 GHz)	(Below 1 GHz)
Mode	Tx BT LE 2480 MHz	

Polarity	Frequency [MHz]	Detector	Reading [dBuV]	Ant.Fac. [dB/m]	Loss [dB]	Gain [dB]	Duty Factor [dB]	Result [dBuV/m]	Limit [dBuV/m]	Margin [dB]	Remark
Hori	56.752	QP	37.4	8.4	7.6	32.2	-	21.2	40.0	18.8	
Hori	77.224	QP	38.8	6.5	7.9	32.2	-	21.0	40.0	19.0	
Hori	123.392	QP	36.3	13.0	8.5	32.2	-	25.6	43.5	17.9	
Hori	212.261	QP	47.6	11.6	9.3	32.1	-	36.4	43.5	7.1	
Hori	221.442	QP	45.9	11.6	9.4	32.1	-	34.8	46.0	11.2	
Hori	474.996	QP	34.6	17.2	11.2	32.0	-	31.0	46.0	15.0	
Hori	2483.500	PK	42.0	27.8	5.8	32.4	-	43.2	73.9	30.7	
Hori	4960.000	PK	42.9	32.1	8.1	31.3	-	51.8	73.9	22.1	
Hori	7440.000	PK	40.7	36.4	9.3	32.2	-	54.2	73.9	19.7	Floor noise
Hori	9920.000	PK	40.5	38.9	10.0	33.1	-	56.3	73.9	17.6	Floor noise
Hori	2483.500	AV	30.5	27.8	5.8	32.4	1.9	33.6	53.9	20.3	*1)
Hori	4960.000	AV	31.6	32.1	8.1	31.3	1.9	42.4	53.9	11.5	
Hori	7440.000	AV	30.5	36.4	9.3	32.2	-	44.0	53.9	9.9	Floor noise
Hori	9920.000	AV	31.1	38.9	10.0	33.1	-	46.9	53.9	7.0	Floor noise
Vert	41.245	QP	46.5	13.8	7.3	32.2	-	35.4	40.0	4.6	
Vert	58.251	QP	46.2	7.9	7.6	32.2	-	29.5	40.0	10.5	
Vert	123.438	QP	41.7	13.0	8.5	32.2	-	31.0	43.5	12.5	
Vert	207.739	QP	44.3	11.5	9.3	32.1	-	33.0	43.5	10.5	
Vert	222.581	QP	47.4	11.6	9.4	32.1	-	36.3	46.0	9.7	
Vert	474.984	QP	34.1	17.2	11.2	32.0	-	30.5	46.0	15.5	
Vert	2483.500	PK	41.1	27.8	5.8	32.4	-	42.3	73.9	31.6	
Vert	4960.000	PK	43.1	32.1	8.1	31.3	-	52.0	73.9	21.9	
Vert	7440.000	PK	41.4	36.4	9.3	32.2	-	54.9	73.9	19.0	Floor noise
Vert	9920.000	PK	40.9	38.9	10.0	33.1	-	56.7	73.9	17.2	Floor noise
Vert	2483.500	AV	33.5	27.8	5.8	32.4	1.9	36.6	53.9	17.3	*1)
Vert	4960.000	AV	33.4	32.1	8.1	31.3	1.9	44.2	53.9	9.7	
Vert	7440.000	AV	30.4	36.4	9.3	32.2	-	43.9	53.9	10.0	Floor noise
Vert	9920.000	AV	30.6	38.9	10.0	33.1	-	46.4	53.9	7.5	Floor noise

Result = Reading + Ant Factor + Loss (Cable+Attenuator+Filter+Distance factor(above 1 GHz)) - Gain(Amplifier) + Duty factor

*Other frequency noises omitted in this report were not seen or had enough margin (more than 20 dB).

Distance factor: 1 GHz - 10 GHz $20\log(4\text{ m} / 3.0\text{ m}) = 2.5\text{ dB}$
10 GHz - 26.5 GHz $20\log(1.0\text{ m} / 3.0\text{ m}) = -9.5\text{ dB}$

*1) Not Out of Band emission(Leakage Power)

Radiated Spurious Emission
(Reference Plot for band-edge)

Report No. 12046146H
Test place Ise EMC Lab.
Semi Anechoic Chamber No.3
Date November 29, 2017
Temperature / Humidity 23 deg. C / 41 % RH
Engineer Takumi Shimada
(1 GHz - 10 GHz)
Mode Tx BT LE 2480 MHz

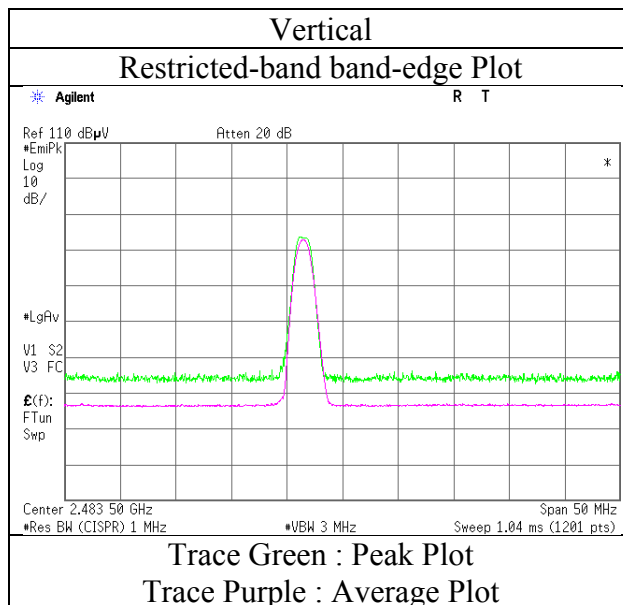
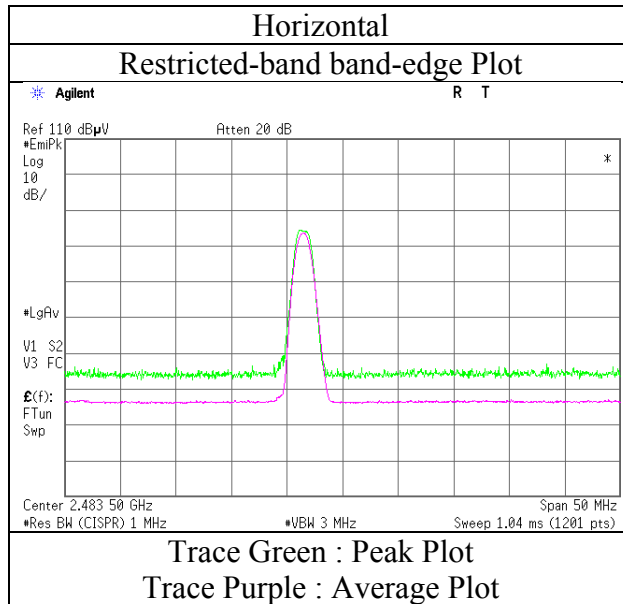

* Final result of restricted band edge was shown in tabular data.

Radiated Spurious Emission
(Plot data, Worst case)

Report No.	12046146H	
Test place	Ise EMC Lab.	
Semi Anechoic Chamber	No.3	No.3
Date	November 29, 2017	December 1, 2017
Temperature / Humidity	23 deg. C / 41 % RH	22 deg. C / 33 % RH
Engineer	Takumi Shimada (Above 1 GHz)	Takumi Shimada (Below 1 GHz)
Mode	Tx BT LE 2440 MHz	

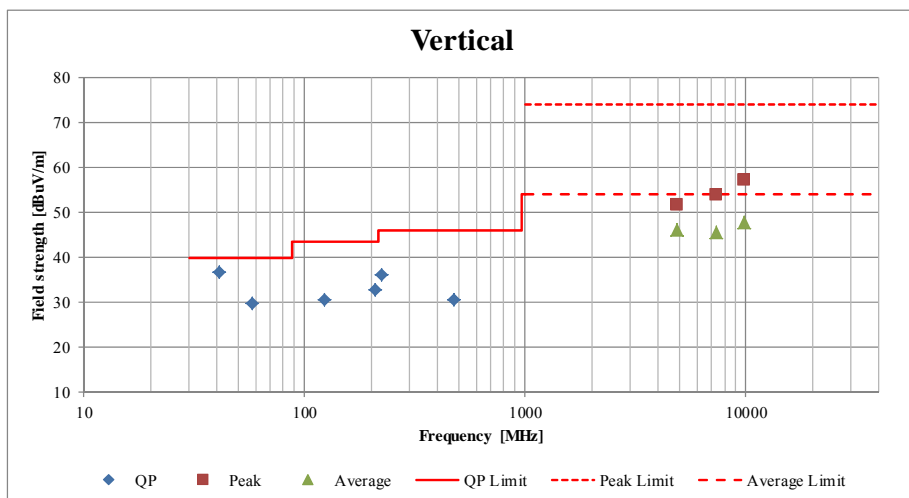
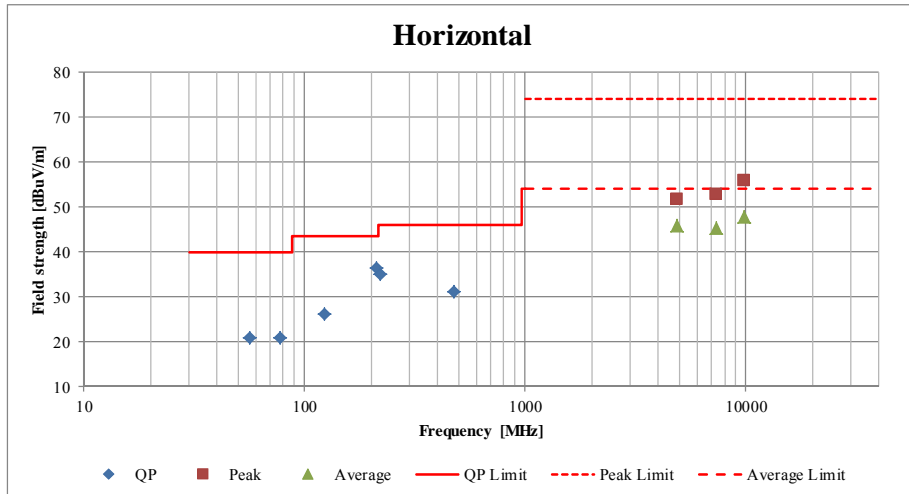

*These plots data contains sufficient number to show the trend of characteristic features for EUT.

APPENDIX 2: Test instruments

Test Instruments

Control No.	Instrument	Manufacturer	Model No	Serial No	Test Item	Calibration Date * Interval(month)
MAEC-03	Semi Anechoic Chamber(NSA)	TDK	Semi Anechoic Chamber 3m	DA-10005	RE	2017/10/31 * 12
MOS-13	Thermo-Hyrometer	Custom	CTH-180	1301	RE	2017/01/20 * 12
MJM-16	Measure	KOMELON	KMC-36	-	RE	-
COTS-MEMI	EMI measurement program	TSJ	TEPTO-DV	-	RE	-
MSA-10	Spectrum Analyzer	Agilent	E4448A	MY46180655	RE	2017/08/22 * 12
MHA-20	Horn Antenna 1-18GHz	Schwarzbeck	BBHA9120D	258	RE	2017/05/22 * 12
MCC-167	Microwave Cable	Junkosha	MWX221	1404S374(1m) / 1405S074(5m)	RE	2017/05/29 * 12
MPA-11	MicroWave System Amplifier	Agilent	83017A	MY39500779	RE	2017/03/21 * 12
MHA-16	Horn Antenna 15-40GHz	Schwarzbeck	BBHA9170	BBHA9170306	RE	2017/05/14 * 12
MMM-08	DIGITAL HiTESTER	Hioki	3805	051201197	RE	2017/01/19 * 12
MHF-25	High Pass Filter 3.5-18.0GHz	UL Japan	HPF SELECTOR	001	RE	2017/09/22 * 12
MTR-08	Test Receiver	Rohde & Schwarz	ESCI	100767	RE	2017/08/22 * 12
MBA-03	Biconical Antenna	Schwarzbeck	BBA9106	1915	RE	2017/10/02 * 12
MLA-22	Logperiodic Antenna(200-1000MHz)	Schwarzbeck	VUSLP9111B	911B-191	RE	2017/01/26 * 12
MCC-51	Coaxial cable	UL Japan	-	-	RE	2017/07/12 * 12
MAT-98	Attenuator	KEYSIGHT	8491A	MY52462349	RE	2016/12/05 * 12
MPA-13	Pre Amplifier	SONOMA INSTRUMENT	310	260834	RE	2017/03/27 * 12

The expiration date of the calibration is the end of the expired month.

All equipment is calibrated with valid calibrations. Each measurement data is traceable to the national or international standards.

As for some calibrations performed after the tested dates, those test equipment have been controlled by means of an unbroken chains of calibrations.

Test item: RE: Radiated Emission test

UL Japan, Inc.

Ise EMC Lab.

4383-326 Asama-cho, Ise-shi, Mie-ken 516-0021 JAPAN

Telephone : +81 596 24 8999

Facsimile : +81 596 24 8124

APPENDIX 3: Photographs of test setup

Radiated Spurious Emission

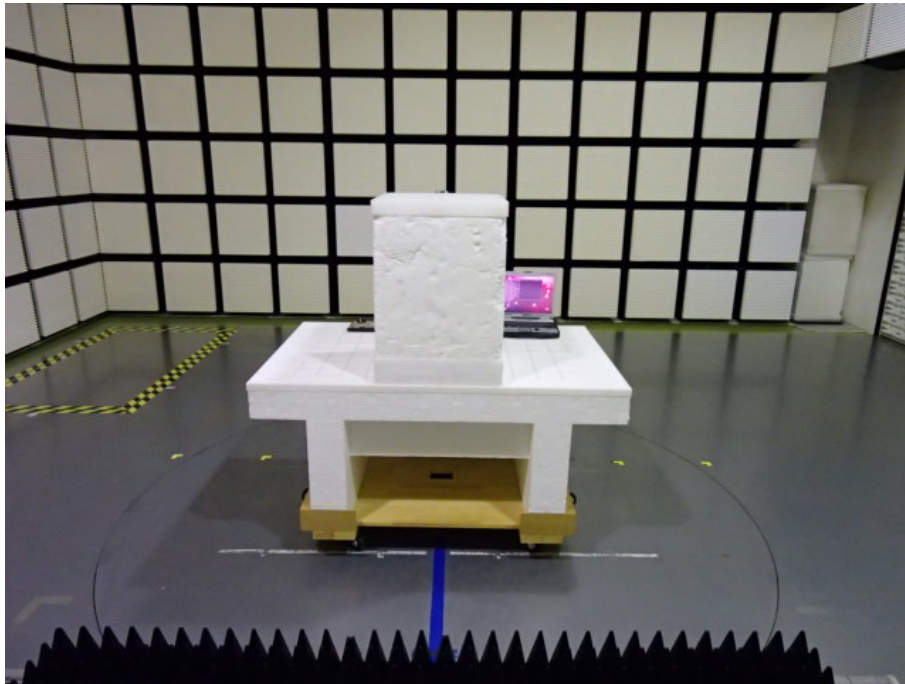

Photo 1

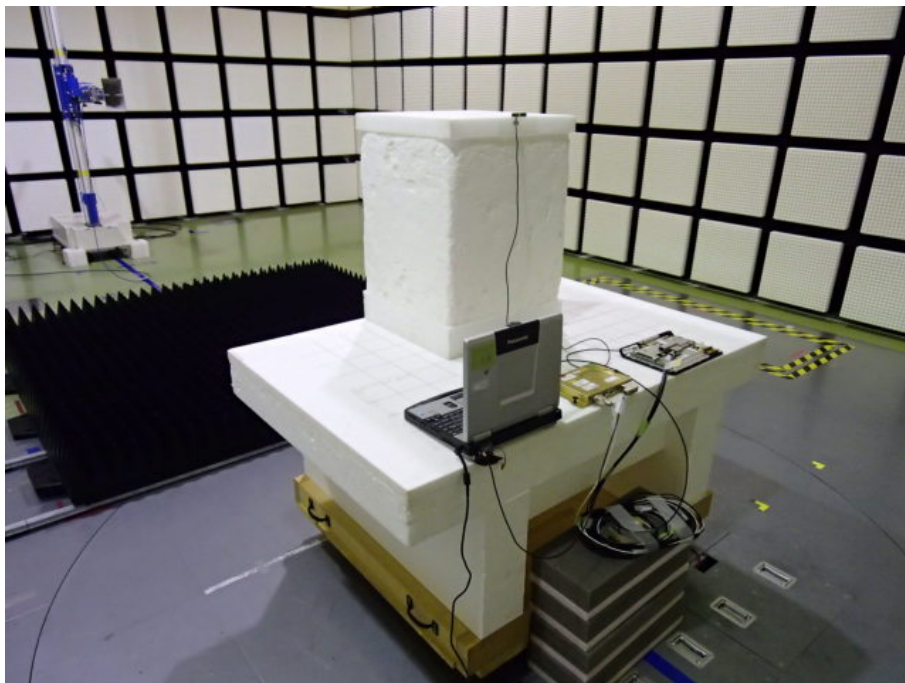

Photo 2

UL Japan, Inc.

Ise EMC Lab.

4383-326 Asama-cho, Ise-shi, Mie-ken 516-0021 JAPAN

Telephone : +81 596 24 8999

Facsimile : +81 596 24 8124

Worst Case Position

Below 1 GHz (Horizontal: X-axis/ Vertical:X-axis)
Above 1 GHz (Horizontal: Y-axis/ Vertical:Z-axis)

X-axis



Y-axis



Z-axis

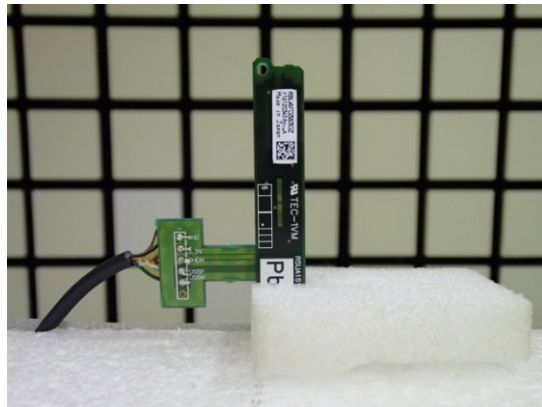

End of Report