



FCC 47 CFR PART 15 SUBPART C: 2008 AND ANSI C63.4: 2003

TEST REPORT

For

11n Wireless Server Router

Model Number: 3R161N

Issued for

E-Top Network Technology Inc.

No. 82, Gongye 2nd Rd., Tainan City 70955, Taiwan, R.O.C.

Issued by

Compliance Certification Services Inc.

Tainan Lab.

**No. 8, Jiu Cheng Ling, Jiaokeng Village, Sinhua
Township, Tainan Hsien 712, Taiwan R.O.C.**

TEL: 886-6-580-2201

FAX: 886-6-580-2202



Note: This report shall not be reproduced except in full, without the written approval of Compliance Certification Services Inc. Ltd. This document may be altered or revised by Compliance Certification Services Inc. personnel only, and shall be noted in the revision section of the document



REVISION HISTORY

Rev.	Issue Date	Revisions	Effect Page	Revised By
00	July 30, 2009	Initial Issue	ALL	Leah Peng



TABLE OF CONTENTS

1. TEST REPORT CERTIFICATION	4
2. EUT DESCRIPTION	5
2.1 DESCRIPTION OF EUT & POWER.....	5
3. DESCRIPTION OF TEST MODES.....	7
4. TEST METHODOLOGY	8
5. FACILITIES AND ACCREDITATIONS.....	8
5.1 FACILITIES	8
5.2 EQUIPMENT	8
5.3 LABORATORY ACCREDITATIONS LISTINGS	8
5.4 TABLE OF ACCREDITATIONS AND LISTINGS.....	9
6. CALIBRATION AND UNCERTAINTY	10
6.1 MEASURING INSTRUMENT CALIBRATION	10
6.2 MEASUREMENT UNCERTAINTY	10
7. SETUP OF EQUIPMENT UNDER TEST	11
7.1 setup configuration of eut	11
7.2 SUPPORT EQUIPMENT	11
7.3 EUT OPERATING CONDITION	12
8. APPLICABLE LIMITS AND TEST RESULTS	13
8.1 6dB BANDWIDTH	13
8.2 MAXIMUM PEAK OUTPUT POWER.....	24
8.3 MAXIMUM PERMISSIBLE EXPOSURE	35
8.4 POWER SPECTRAL DENSITY.....	37
8.5 CONDUCTED SPURIOUS EMISSION.....	47
8.6 RADIATED EMISSIONS	60
8.7 POWERLINE CONDUCTED EMISSIONS.....	107
9. ANTENNA REQUIREMENT	111
9.1 STANDARD APPLICABLE.....	111
9.2 ANTENNA CONNECTED CONSTRUCTION	111
APPENDIX SETUP PHOTOS.....	112



1. TEST REPORT CERTIFICATION

Applicant : E-Top Network Technology Inc.

Address : No. 82, Gongye 2nd Rd., Tainan City 70955, Taiwan, R.O.C.

Manufacture : CNet Technology Inc.

Address : 1F, No.30, Industry E.RD.IX, Science-Based Industrial Park, Hsin-Chu, Taiwan, R.O.C.

Equipment Under Test : 11n Wireless Server Router

Model Number : 3R161N

Date of Test : June 9, 2009, July 28, 2009

APPLICABLE STANDARD	
STANDARD	TEST RESULT
FCC Part 15 Subpart C : 2008 AND ANSI C63.4 : 2003	No non-compliance noted

Approved by:

Jeter Wu
Section Manager
Compliance Certification Services Inc.

Reviewed by:

Eric Yang
Senior Engineer
Compliance Certification Services Inc.



2. EUT DESCRIPTION

2.1 DESCRIPTION OF EUT & POWER

Product Name	11n Wireless Server Router
Model Number	3R161N
Frequency Range	IEEE 802.11b/g, 802.11n HT20 (DTS Band):2412MHz~2462MHz IEEE 802.11n HT40 (DTS Band):2422MHz~2452MHz
Transmit Power	IEEE 802.11b Mode : 21.63dBm (DTS Band) (145.546 mW) IEEE 802.11g Mode : 22.22dBm (DTS Band) (166.725 mW) IEEE 802.11n HT20 Mode : 21.67dBm (DTS Band) (146.893 mW) IEEE 802.11n HT40 Mode : 21.43dBm (DTS Band) (138.995 mW)
Channel Spacing	IEEE 802.11b/g, 802.11n HT20/HT40: 5MHz
Channel Number	IEEE 802.11b/g, 802.11n HT20:11 Channels IEEE 802.11n HT40 :7 Channels
Transmit Data Rate	IEEE 802.11b : 11, 5.5, 2, 1 Mbps IEEE 802.11g : 54, 48, 36, 24, 18, 12, 9, 6 Mbps IEEE 802.11n HT20 : 130, 117, 104, 78, 65, 58.5, 52, 39, 26, 19.5, 13, 6.5 Mbps IEEE 802.11n HT40 : 270, 243, 216, 162, 135, 121.5, 108, 81, 54, 40.5, 27, 13.5 Mbps
Type of Modulation	IEEE 802.11b : DSSS (CCK, DQPSK, DBPSK) IEEE 802.11g : OFDM (64QAM, 16QAM, QPSK, BPSK) IEEE 802.11n HT20/40 : OFDM (64QAM, 16QAM, QPSK, BPSK)
Frequency Selection	By software / firmware
Antenna Type	Two antennas 1Tx 2Rx I-PEX PIFA Antenna (× 1) 1TX1RX Manufacture: SOCAA CORP. LTD. Model: 9806118-A Connector: I-PEX Type: PIFA Gain: 2.0 dBi Printed Antenna (× 1) 1RX Gain: 0 dBi
Power Source	Adapt AC 100 V ~ 240 V in / DC5V 1.5A output
Temperature Range	0 ~ +55°C

- REMARK:**
1. The sample selected for test was engineering sample that approximated to production product and was provided by manufacturer.
 2. This submittal(s) (test report) is intended for FCC ID: **U6A-3R161N** filing to comply with Section 15.207,15.209 and 15.247 of the FCC Part 15, Subpart C Rules.
 3. For more details, please refer to the User's manual of the EUT.
 4. To add a series model is for business necessary. The different of the each model is shown as below:

**Multiple Listing:**

Company Name/ Address	Brand Name	Model Name	Product Name
E-Top Network Technology Inc. No. 82 ,Gongye 2nd Rd.,Tainan City 70955,Taiwan,R.O.C.	ETOP	3R161N	11n Wireless Server Router
Amigo Technology Inc. 1F, No. 333, Sec. 1, Ti-Ding BLVD., NeiHu, Taipei 114, Taiwan	Amigo	3R161N	11n Wireless Server Router
CNet Technology Inc. 1F,No.30,Industry E.RD.IX,Science-Based Industrial Park,Hsin-Chu,Taiwan,R.O.C.	CNet	CWR-935M	Wireless-N Mobile Router
Sapido Technology Inc. No. 383., Sec. 2, Minsheng Rd., West Central District, Tainan 700, Taiwan, R.O.C.	SAPIDO	GR-1102	N+ NES Mini Server



3. DESCRIPTION OF TEST MODES

The EUT is a 11n Wireless Server Router. It has one transmitter chain and two receive chain (1x2 configurations). The 1x2 configuration is implemented with one outside chain 0

The antenna peak gain 2.0dBi (highest gain) were chosen for full testing.

The RF chipset is manufactured by Realtek Semiconductor Corp.

IEEE 802.11 b ,802.11g ,802.11n HT20 mode (DTS Band)

The EUT had been tested under operating condition.

There are three channels have been tested as following:

Channel	Frequency (MHz)
Low	2412
Middle	2437
High	2462

IEEE 802.11b mode: 11Mbps data rates (worst case) were chosen for full testing.

IEEE 802.11g mode: 6Mbps data rates (worst case) were chosen for full testing.

IEEE 802.11n HT20 mode: 6.5Mbps data rates (worst case) were chosen for full testing.

IEEE 802.11n HT40 mode (DTS Band)

The EUT had been tested under operating condition.

There are three channels have been tested as following:

Channel	Frequency (MHz)
Low	2422
Middle	2437
High	2452

IEEE 802.11n HT40 mode: 13.5Mbps data rates (worst case) were chosen for full testing.

The worst-case data rates are determined according to the description above, based on the investigations by measuring the PSD, peak power and average power across all the data rates, bandwidths, modulations and spatial stream modes.



4. TEST METHODOLOGY

The tests documented in this report were performed in accordance with ANSI C63.4 and FCC CFR 47 15.207, 15.209 and 15.247.

5. FACILITIES AND ACCREDITATIONS

5.1 FACILITIES

All measurement facilities used to collect the measurement data are located at

No. 8, Jiu Cheng Ling, Jiaokeng Village, Sinhua Township, Tainan Hsien 712, Taiwan R.O.C.

The sites are constructed in conformance with the requirements of ANSI C63.7:1992, ANSI C63.4: 2003 and CISPR Publication 22.

5.2 EQUIPMENT

Radiated emissions are measured with one or more of the following types of linearly polarized antennas: tuned dipole, biconical, log periodic, bi-log, and/or ridged waveguide, horn. Spectrum analyzers with preselectors and quasi-peak detectors are used to perform radiated measurements.

Conducted emissions are measured with Line Impedance Stabilization Networks and EMI Test Receivers.





Calibrated wideband preamplifiers, coaxial cables, and coaxial attenuators are also used for making measurements.

All receiving equipment conforms to CISPR Publication 16-1, "Radio Interference Measuring Apparatus and Measurement Methods."

5.3 LABORATORY ACCREDITATIONS LISTINGS

The test facilities used to perform radiated and conducted emissions tests are accredited by Taiwan Accreditation Foundation for the specific scope of accreditation under Lab Code: 1109 to perform Electromagnetic Interference tests according to FCC PART 15 AND CISPR 22 requirements. No part of this report may be used to claim or imply product endorsement by TAF or any agency of the Government. In addition, the test facilities are listed with Federal Communications Commission (registration no: TW-1037).

5.4 TABLE OF ACCREDITATIONS AND LISTINGS

Country	Agency	Scope of Accreditation	Logo
USA	FCC	3/10 meter Open Area Test Sites to perform FCC Part 15/18 measurements	 TW-1037
Japan	VCCI	3/10 meter Open Area Test Sites and conducted test sites to perform radiated/conducted measurements	 C-2882 R-2635
Taiwan	TAF	CISPR 11, FCC METHOD-47 CFR Part 18, EN 55011, EN 60601-1-2, CISPR 22, CNS 13438, EN 55022, EN 55024, AS/NZS CISPR 22 CISPR 14, EN 55014-1, EN 55014-2, CNS 13783-1, CISPR 22, CNS 13439, EN 55013, FCC Method-47 CFR Part 15 Subpart B, IC ICES-003, VCCI V-3 & V-4 FCC Method-47 CFR Part 15 Subpart C and ANSI C63.4, LP 0002 EN / IEC 61000-4-2 / -3 / -4 / -5 / -6 / -8 / -11 EN 61000-3-2, EN 61000-3-3 EN 61000-6-3, EN 61000-6-1, AS/NZS 4251.1, EN 61000-6-4, EN 61000-6-2, AS/NZS 4251.2, EN 61204-3, EN 50130-4, EN 62040-2, EN 50371, EN 50385, AS/NZS 4268, ETSI EN 300 386 ETSI EN 300 328, ETSI EN 301 489-1/-3/-9/-17 ETSI EN 301 893, ETSI EN 300 220-2/-1 ETSI EN 300 440-2/-1 ETSI EN 301 357-2/-1 RSS-310, RSS-210 Issue 7, RSS-Gen Issue 2	
Taiwan	BSMI	CNS 13438, CNS 13783-1, CNS13439	 SL2-IN-E-0039 SL2-R1/R2-0039 SL2-A1-E-0039
Canada	Industry Canada	RSS210, Issue 7	 IC 2324H-1

* No part of this report may be used to claim or imply product endorsement by TAF or any agency of the US Government.



6. CALIBRATION AND UNCERTAINTY

6.1 MEASURING INSTRUMENT CALIBRATION

The measuring equipment utilized to perform the tests documented in this report has been calibrated in accordance with the manufacturer's recommendations, and is traceable to recognized national standards.

6.2 MEASUREMENT UNCERTAINTY

Where relevant, the following measurement uncertainty levels have been estimated for tests performed on the apparatus:

PARAMETER	UNCERTAINTY
Radiated Emission, 30 to 1000 MHz	+/- 3.2 dB
Radiated Emission, 1 to 26.5 GHz	+/- 3.2 dB
Power Line Conducted Emission	+/- 2.1 dB

This measurement uncertainty is confidence of approximately 95%, k=2

7. SETUP OF EQUIPMENT UNDER TEST

7.1 SETUP CONFIGURATION OF EUT

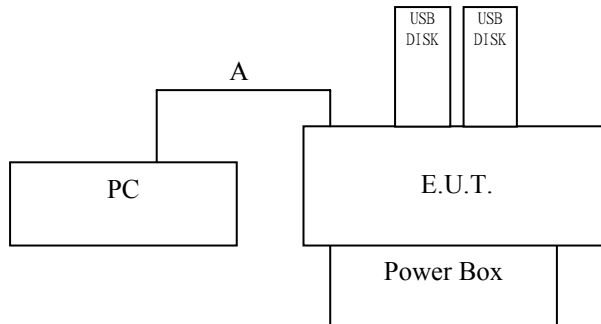

7.2 SUPPORT EQUIPMENT

No.	Product	Manufacturer	Model No.	FCC ID	Signal Cable
1	PC	HP	D330uT	DOC	Power cable, unshd, 1.5m
2	Flash Disk	Kingston	DTI/512	DOC	N/A
3	Flash Disk	Kingston	DTI/512	DOC	N/A

No.	Signal cable description	
A	RJ 45 cable	Unshielded, 1.8m, 1pcs.

REMARK:

1. All the above equipment/cables were placed in worse case positions to maximize emission signals during emission test.
2. Grounding was established in accordance with the manufacturer's requirements and conditions for the intended use.



7.3 EUT OPERATING CONDITION

RF Setup

1. Before connecting power ,press reset key ,10 seconds after transmit power ,unlock reset key
2. Enter Dos under the environment of Release-V2-0 materials are inserted ,carried out batch shelf
Put first
3. Carry out MP Test.exe
4. Set b/g/n mode ,con TX/RX ,channel,bandwidth,data rate,transmit power
5. Start to test

TX Mode:

- ⇒ **Tx Mode:**CCK 、OFDM 、 HT MixMode (Bandwidth: 20 、 40)
- ⇒ **Tx Data Rate:** 11Mbps long (IEEE 802.11b mode)
6Mbps (IEEE 802.11g mode)
6.5Mbps (IEEE 802.11n HT20 mode)
13.5Mbps (IEEE 802.11n HT40 mod)

Power control mode

- Target Power:** IEEE 802.11b Channel Low (2412MHz) = **31**
IEEE 802.11b Channel Middle (2437MHz) = **31**
IEEE 802.11b Channel High (2462MHz) = **31**
- Target Power:** IEEE 802.11g Channel Low (2412MHz) = **31**
IEEE 802.11g Channel Middle (2437MHz) = **31**
IEEE 802.11g Channel High (2462MHz) = **31**
- Target Power:** IEEE 802.11n HT20 Channel Low (2412MHz) = **31**
IEEE 802.11 n HT20 Channel Middle (2437MHz) = **31**
IEEE 802.11 n HT20 Channel High (2462MHz) = **31**
- Target Power:** IEEE 802.11n HT40 Channel Low (2422MHz) = **31**
IEEE 802.11 n HT40 Channel Middle (2437MHz) = **31**
IEEE 802.11 n HT40 Channel High (2452MHz) = **31**

(2) RX Mode :

Start RX

3. All of the function are under run.
4. Start test.

Normal Link Setup

1. Set up all computers like the setup diagram.
 2. All of the function are under run.
 3. Notebook PC (2) ping 192.168.0.10 -t to Notebook PC (1).
 4. Notebook PC (1) ping 192.168.0.20 -t to Notebook PC (2).
 5. Notebook PC (1) ping 192.168.0.50 -t to Wireless Access Point (3).
- Start test.



8. APPLICABLE LIMITS AND TEST RESULTS

8.1 6DB BANDWIDTH

LIMIT

§ 15.207(a) (2) For direct sequence systems, the minimum 6dB bandwidth shall be at least 500kHz

TEST EQUIPMENTS

Name of Equipment	Manufacturer	Model	Serial Number	Calibration Due
Spectrum Analyzer	R&S	FSEK 30	835253/002	OCT. 14, 2009

TEST SETUP

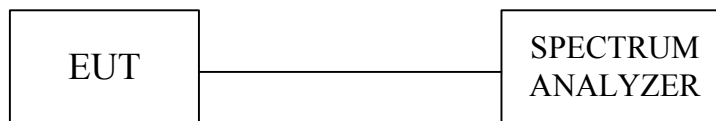

TEST PROCEDURE

The transmitter output was connected to a spectrum analyzer. The bandwidth of the fundamental frequency was measured by spectrum analyzer with 100 KHz RBW and 100 KHz VBW. The 6dB bandwidth is defined as the total spectrum the power of which is higher than peak power minus 6dB.

**TEST RESULTS**

No non-compliance noted.

IEEE 802.11b mode

Channel	Channel Frequency (MHz)	6dB Bandwidth (kHz)	Minimum Limit (kHz)	Pass / Fail
Low	2412	10220	500	PASS
Middle	2437	10235	500	PASS
High	2462	10215	500	PASS

NOTE :

1. At final test to get the worst-case emission at 11Mbps.
2. The cable assembly insertion loss of 11.7dB (including 10 dB pad and 1.7 dB cable) was entered as an offset in the spectrum analyzer to allow for direct reading of power.

IEEE 802.11g mode

Channel	Channel Frequency (MHz)	6dB Bandwidth (kHz)	Minimum Limit (kHz)	Pass / Fail
Low	2412	16629	500	PASS
Middle	2437	16628	500	PASS
High	2462	16633	500	PASS

NOTE :

1. At final test to get the worst-case emission at 6Mbps.
2. The cable assembly insertion loss of 11.7dB (including 10 dB pad and 1.7 dB cable) was entered as an offset in the spectrum analyzer to allow for direct reading of power.

**IEEE 802.11n HT20 mode**

Channel	Channel Frequency (MHz)	6dB Bandwidth (kHz)	Minimum Limit (kHz)	Pass / Fail
Low	2412	17835	500	PASS
Middle	2437	17823	500	PASS
High	2462	17827	500	PASS

- NOTE :**
1. At final test to get the worst-case emission at 6.5Mbps.
 2. The cable assembly insertion loss of 11.7dB (including 10 dB pad and 1.7 dB cable) was entered as an offset in the spectrum analyzer to allow for direct reading of power.

IEEE 802.11n HT40 mode

Channel	Channel Frequency (MHz)	6dB Bandwidth (kHz)	Minimum Limit (kHz)	Pass / Fail
Low	2422	36473	500	PASS
Middle	2437	36475	500	PASS
High	2452	36472	500	PASS

- NOTE :**
1. At final test to get the worst-case emission at 13.5Mbps.
 2. The cable assembly insertion loss of 11.7dB (including 10 dB pad and 1.7 dB cable) was entered as an offset in the spectrum analyzer to allow for direct reading of power.



6dB BANDWIDTH (802.11b MODE)

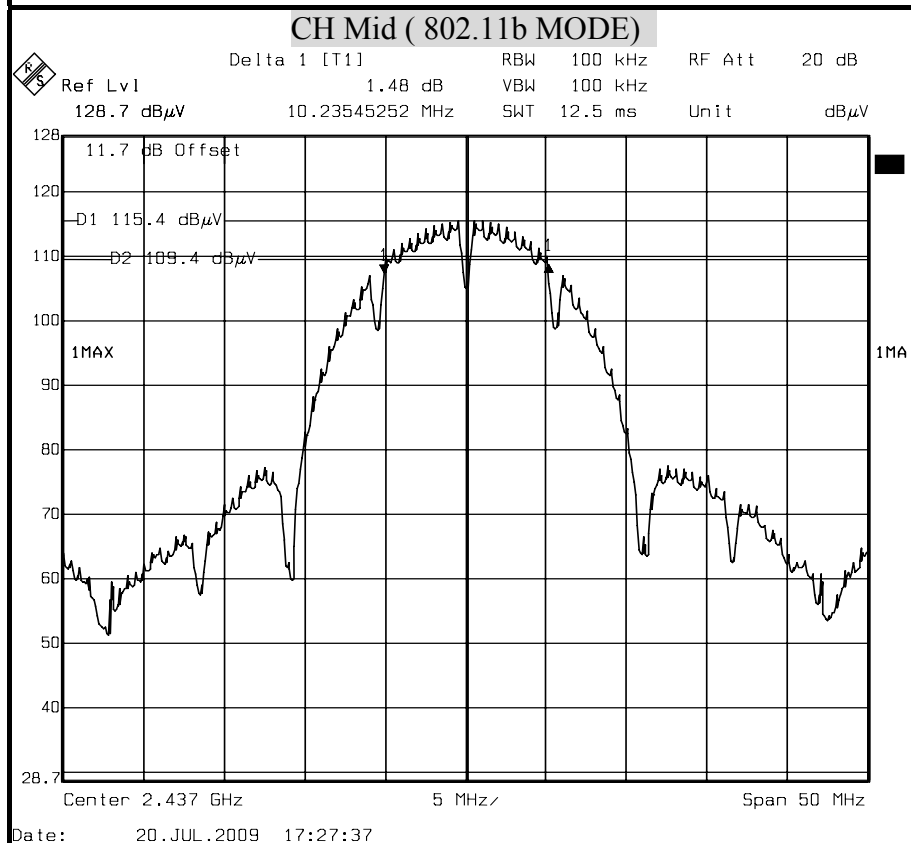
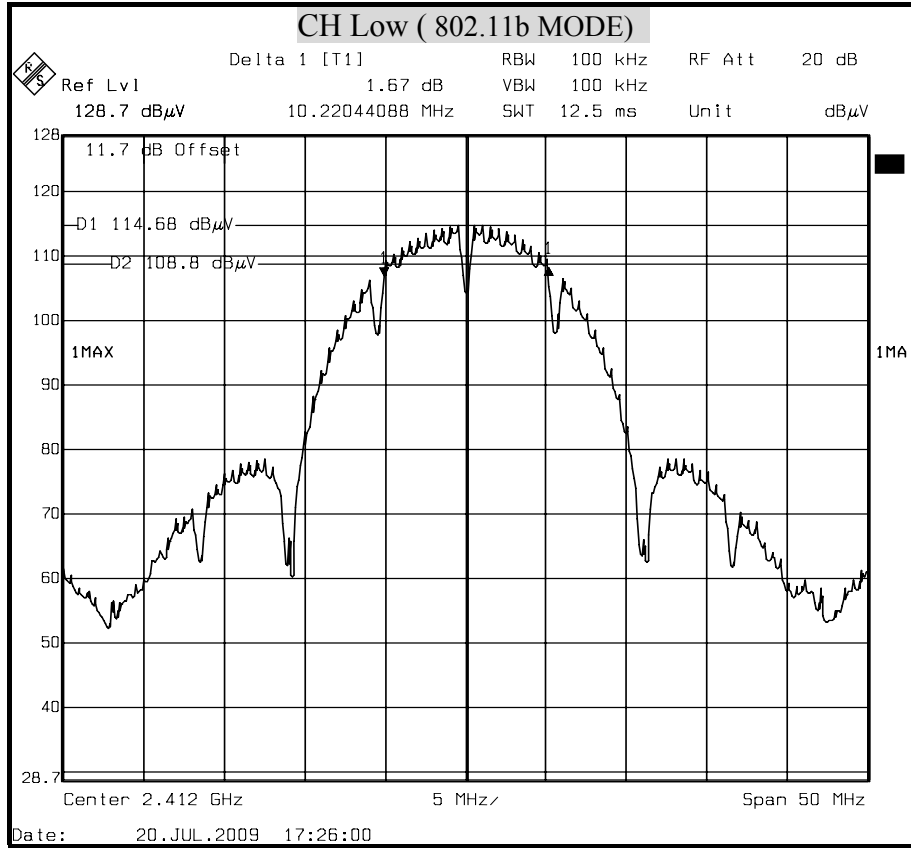

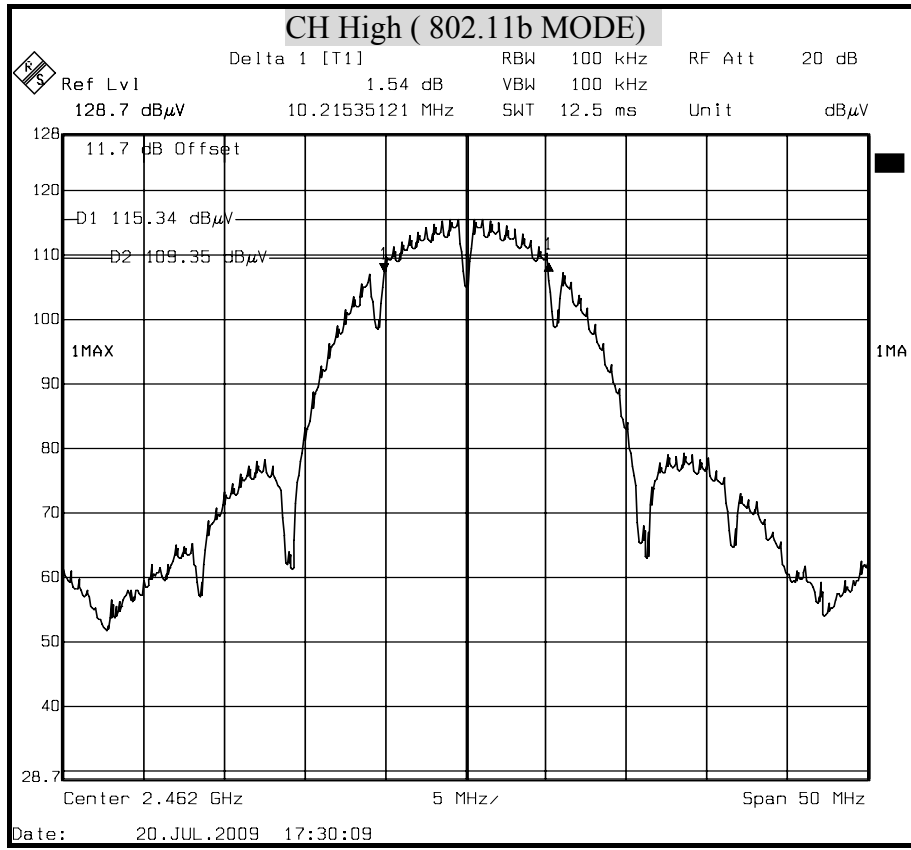



6dB BANDWIDTH (802.11g MODE)

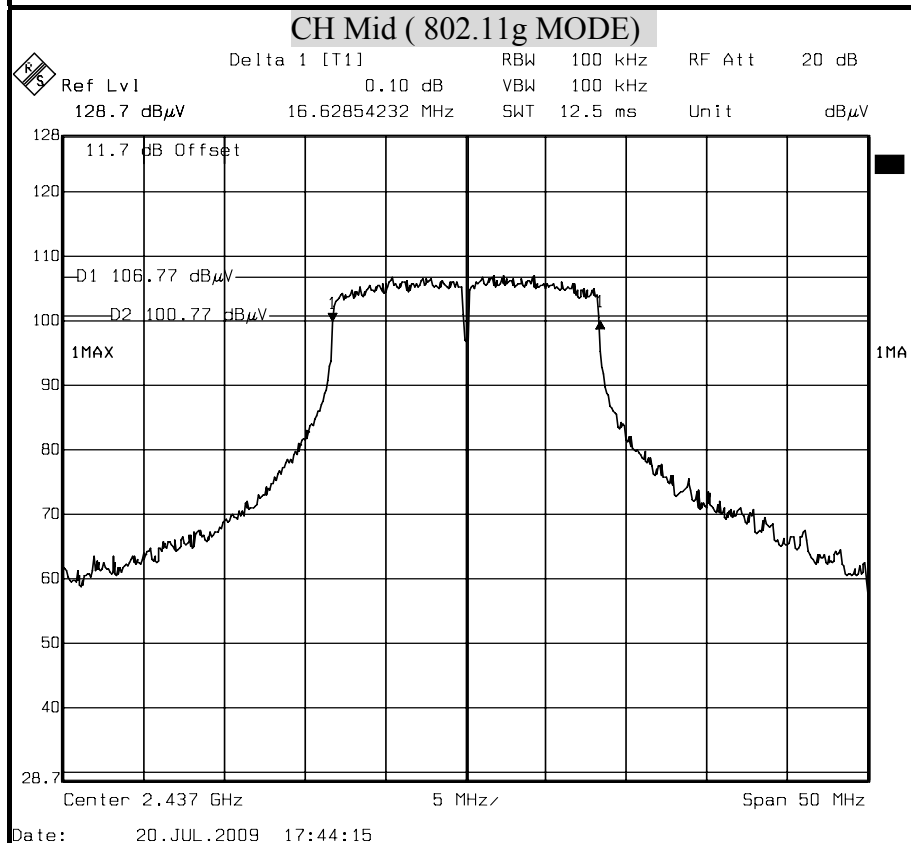
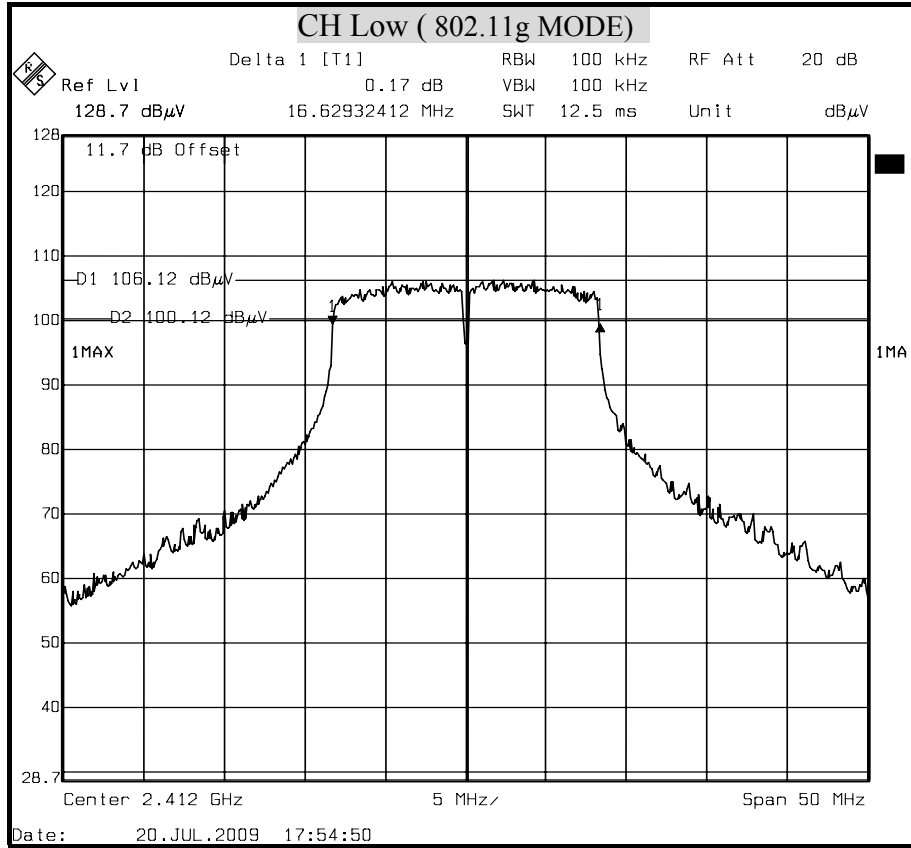

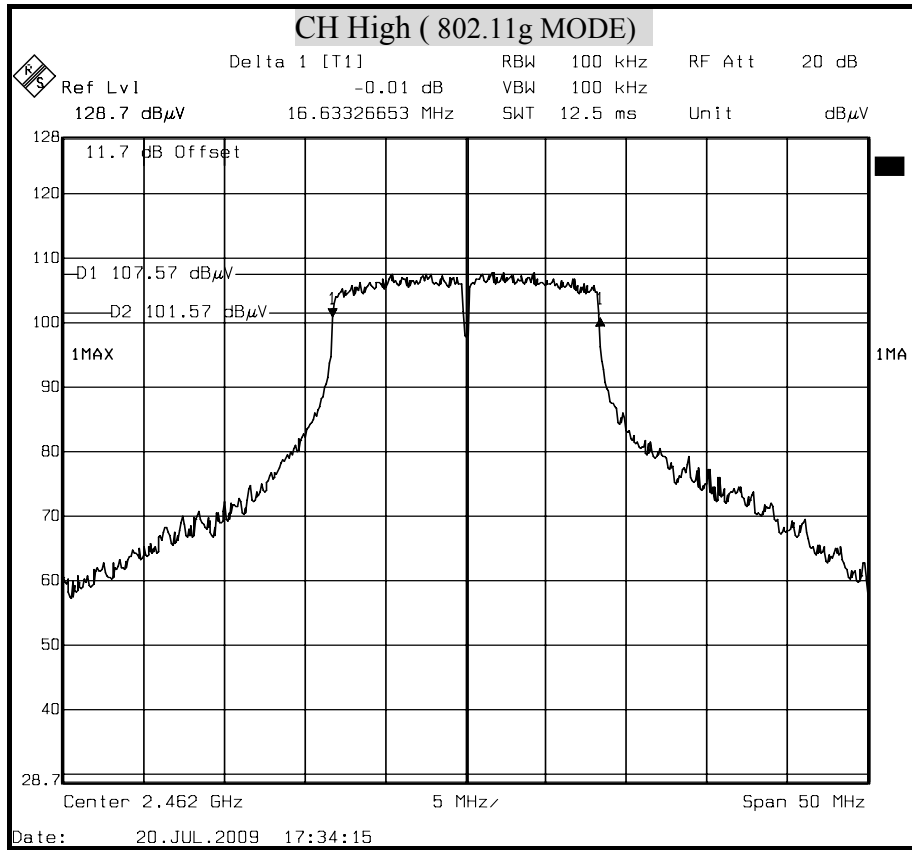



6dB BANDWIDTH (802.11n HT20 MODE)

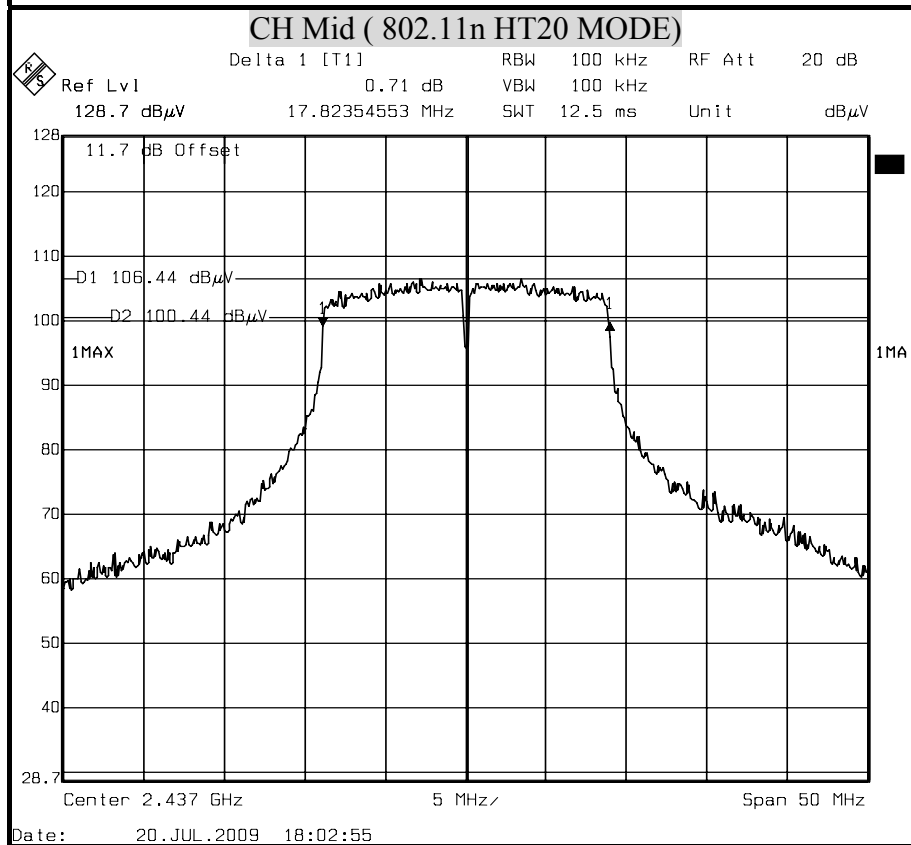
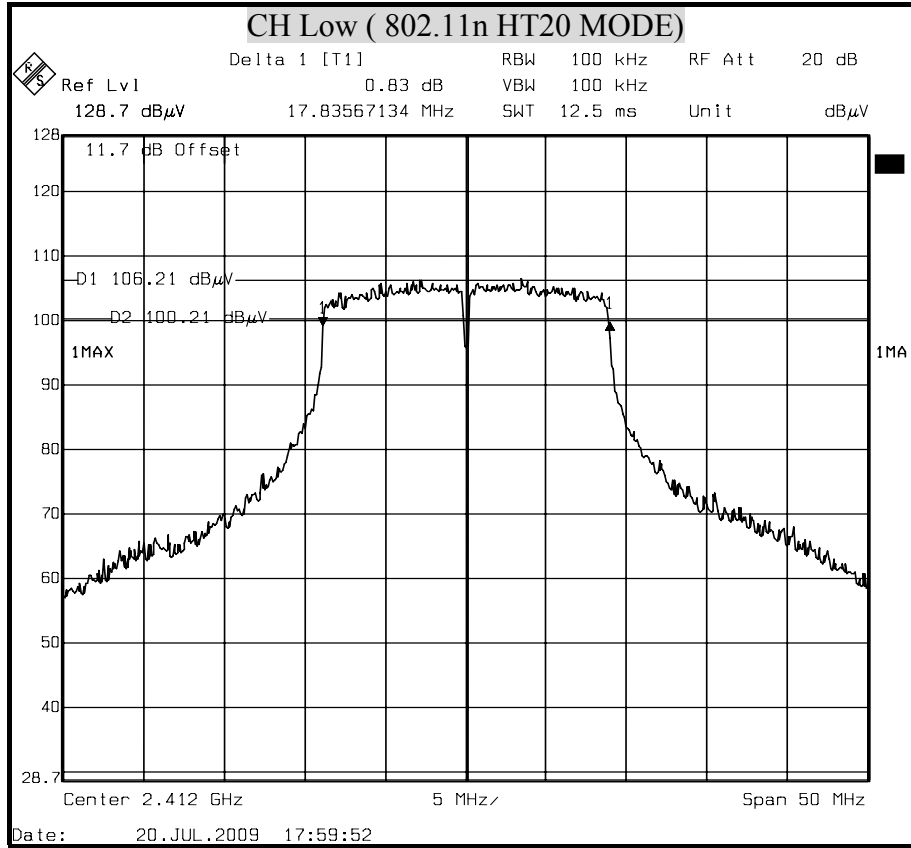

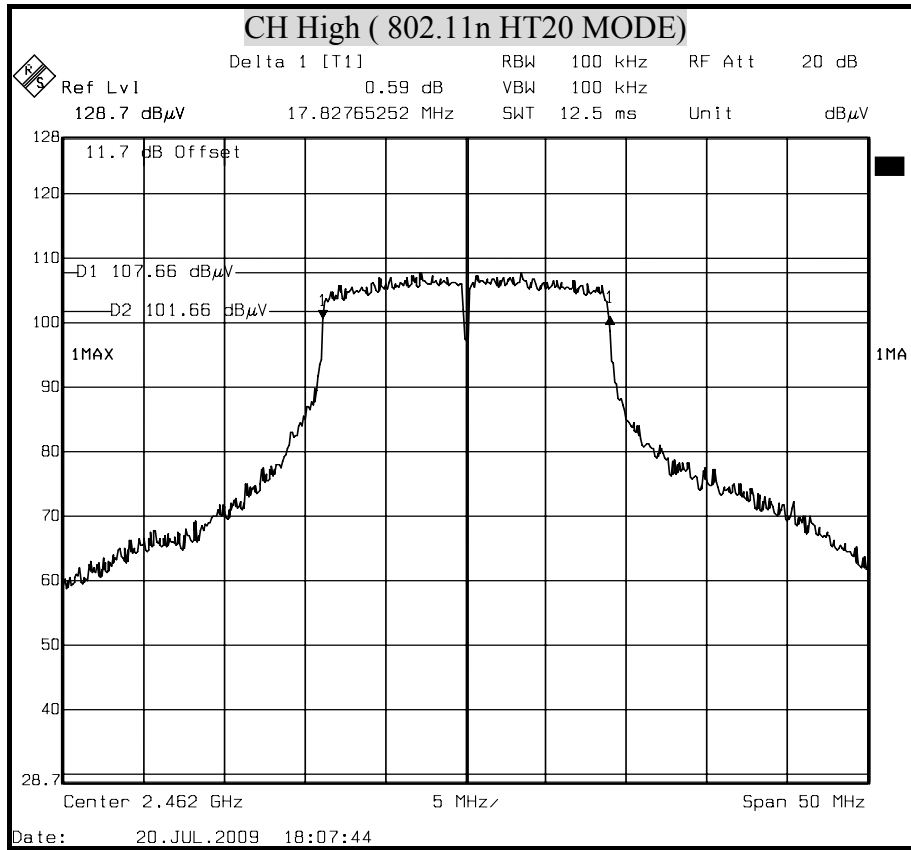



6dB BANDWIDTH (802.11n HT40 MODE)

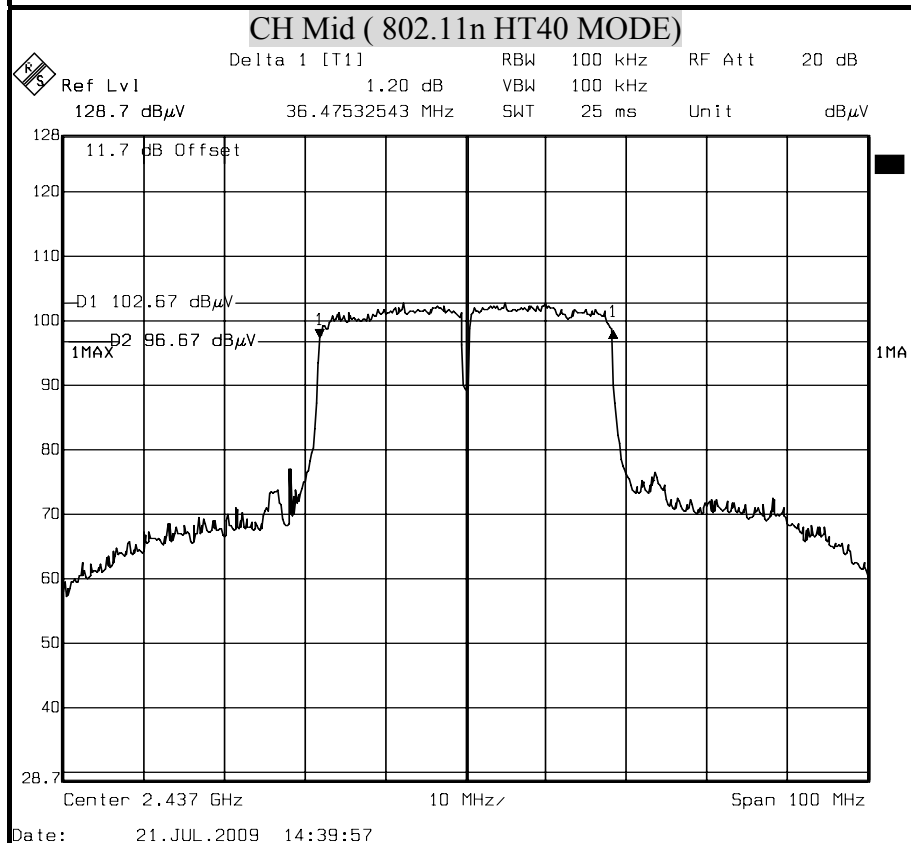
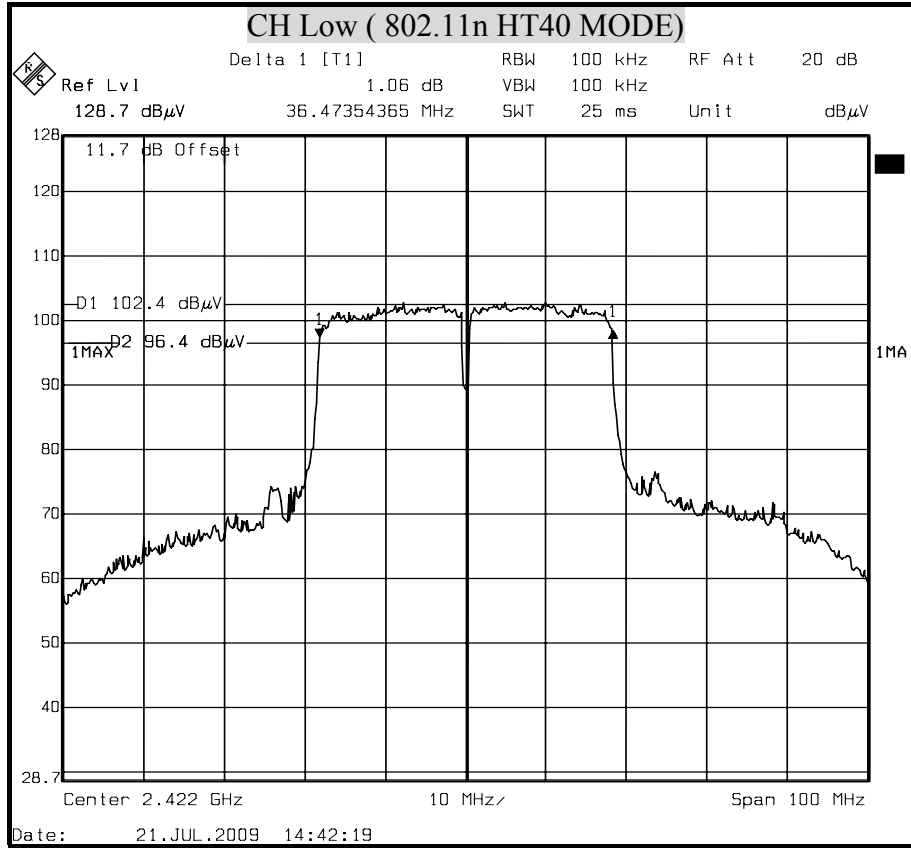

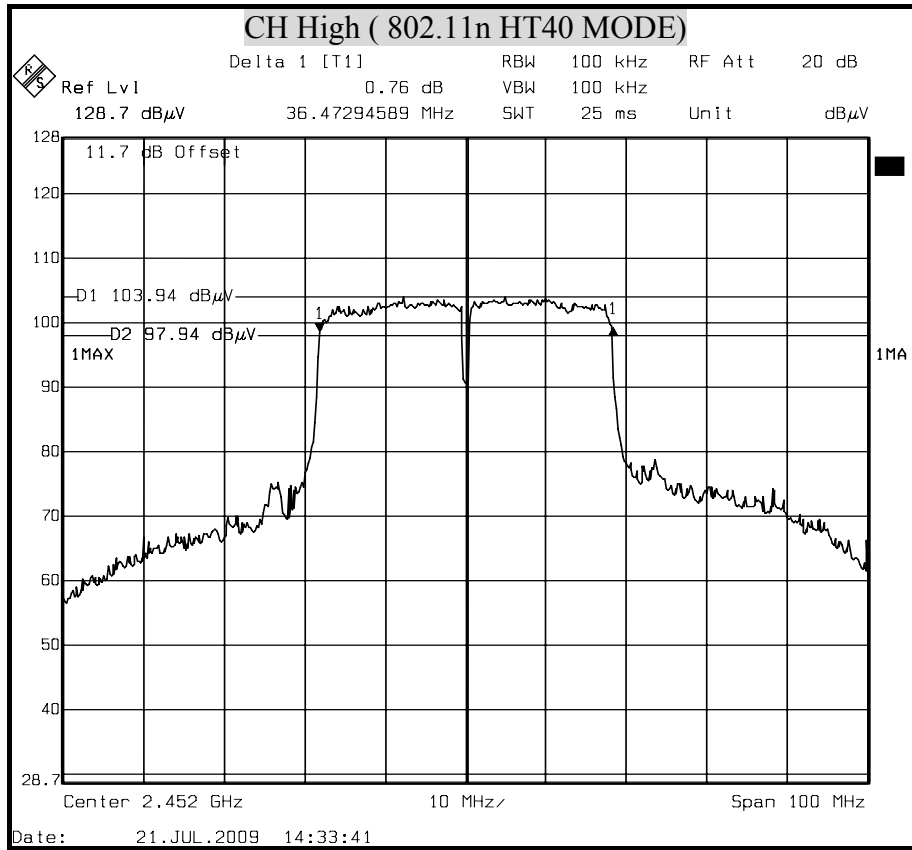



8.2 MAXIMUM PEAK OUTPUT POWER

LIMIT

§ 15.247(b) The maximum peak output power of the intentional radiator shall not exceed the following :

§ 15.247(b) (3) For systems using digital modulation in the 902-928 MHz, 2400-2483.5 MHz, and 5725-5850 MHz bands : 1 watt.

§ 15.247(b) (4) Except as shown in paragraphs (c) of this section , if transmitting antennas of directional gain greater than 6 dBi are used the peak output power from the intentional radiator shall be reduced below the stated values in paragraphs (b)(1) or (b)(2), and (b)(3) of this section , as appropriate, by the amount in dB that the directional gain of the antenna exceeds 6 dBi.

TEST EQUIPMENTS

Name of Equipment	Manufacturer	Model	Serial Number	Calibration Due
Spectrum Analyzer	R&S	FSEK 30	835253/002	OCT. 14, 2009

TEST SETUP

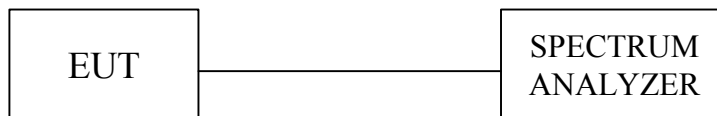

TEST PROCEDURE

Connect the EUT to spectrum analyzer, set the center frequency of the spectrum analyzer to the channel center frequency. Set the RBW to 1MHz and VBW to 3MHz.

TEST RESULTS

No non-compliance noted

**IEEE 802.11b mode**

Channel	Channel Frequency (MHz)	Peak Power (dBm)	Peak Power Limit (dBm)	Pass / Fail
Low	2412	20.31	30	PASS
Middle	2437	21.33	30	PASS
High	2462	21.63	30	PASS

- NOTE :**
1. At final test to get the worst-case emission at 11Mbps.
 2. The cable assembly insertion loss of 11.7dB (including 10 dB pad and 1.7 dB cable) was Entered as an offset in the spectrum analyzer to allow for direct reading of power.

IEEE 802.11g mode

Channel	Channel Frequency (MHz)	Peak Power (dBm)	Peak Power Limit (dBm)	Pass / Fail
Low	2412	20.72	30	PASS
Middle	2437	20.94	30	PASS
High	2462	22.22	30	PASS

- NOTE :**
1. At final test to get the worst-case emission at 6Mbps.
 2. The cable assembly insertion loss of 11.7dB (including 10 dB pad and 1.7 dB cable) was Entered as an offset in the spectrum analyzer to allow for direct reading of power.

**IEEE 802.11n HT20 mode**

Channel	Channel Frequency (MHz)	Peak Power (dBm)	Peak Power Limit (dBm)	Pass / Fail
Low	2412	20.92	30	PASS
Middle	2437	21.13	30	PASS
High	2462	21.67	30	PASS

- NOTE :**
1. At final test to get the worst-case emission at 6.5Mbps.
 2. The cable assembly insertion loss of 11.7dB (including 10 dB pad and 1.7 dB cable) was Entered as an offset in the spectrum analyzer to allow for direct reading of power.

IEEE 802.11n HT40 mode

Channel	Channel Frequency (MHz)	Peak Power (dBm)	Peak Power Limit (dBm)	Pass / Fail
Low	2422	20.68	30	PASS
Middle	2437	20.53	30	PASS
High	2452	21.43	30	PASS

- NOTE :**
1. At final test to get the worst-case emission at 13.5Mbps.
 2. The cable assembly insertion loss of 11.7dB (including 10 dB pad and 1.7 dB cable) was Entered as an offset in the spectrum analyzer to allow for direct reading of power.



MAXIMUM PEAK OUTPUT POWER (802.11b MODE)

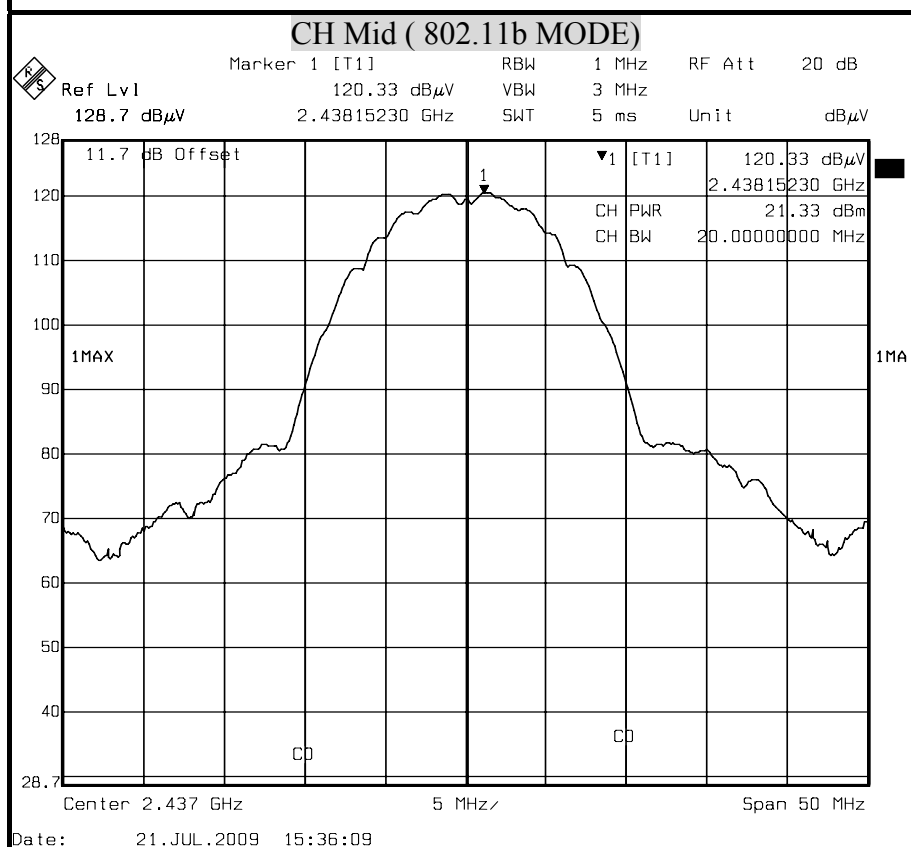
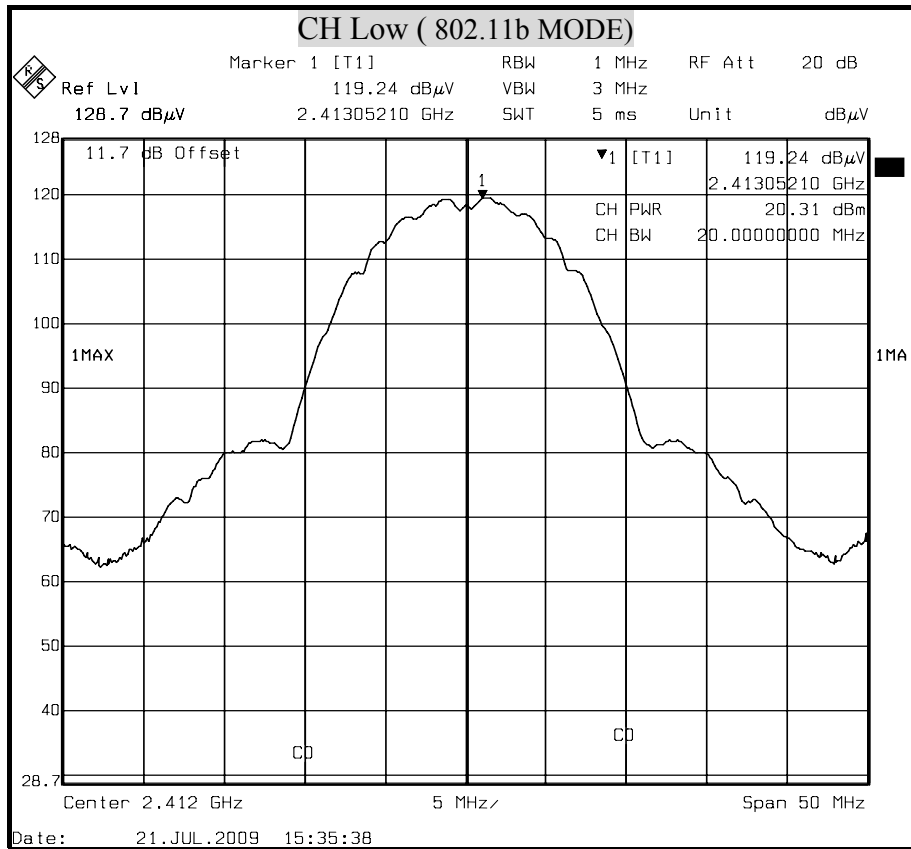

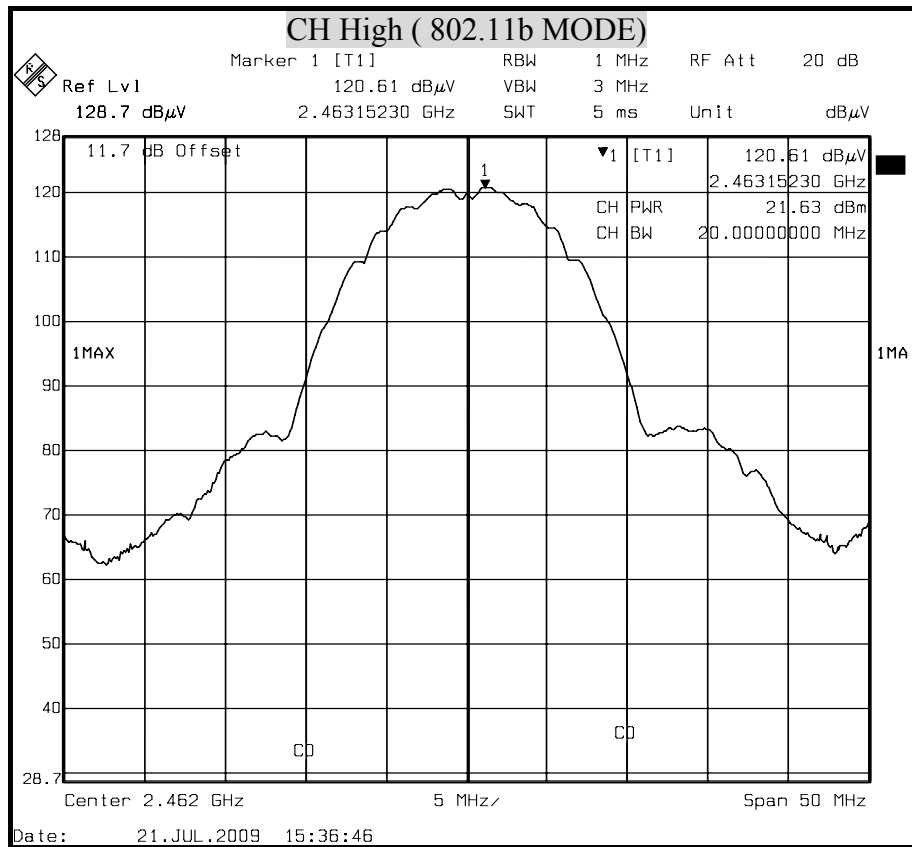



MAXIMUM PEAK OUTPUT POWER (802.11g MODE)

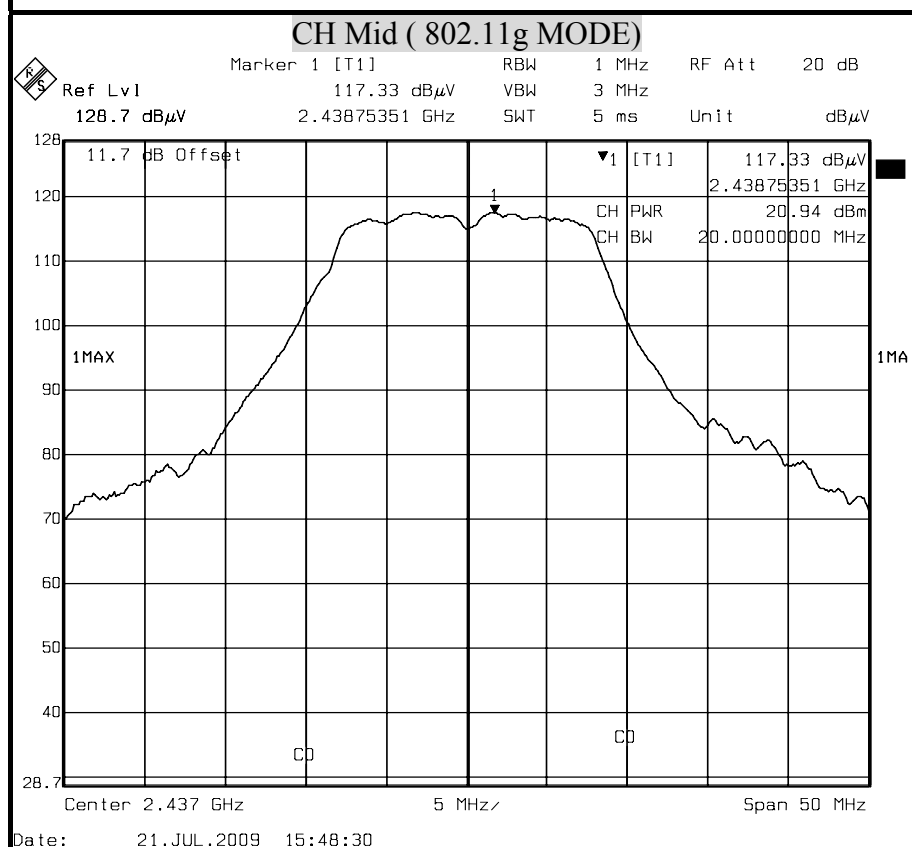
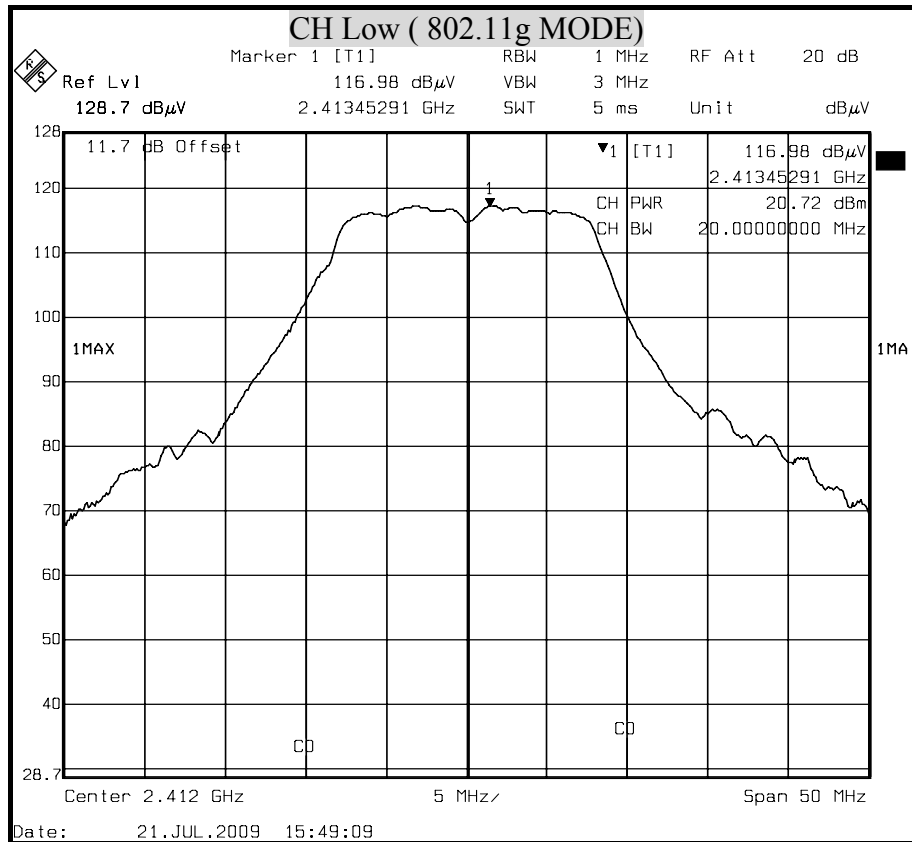

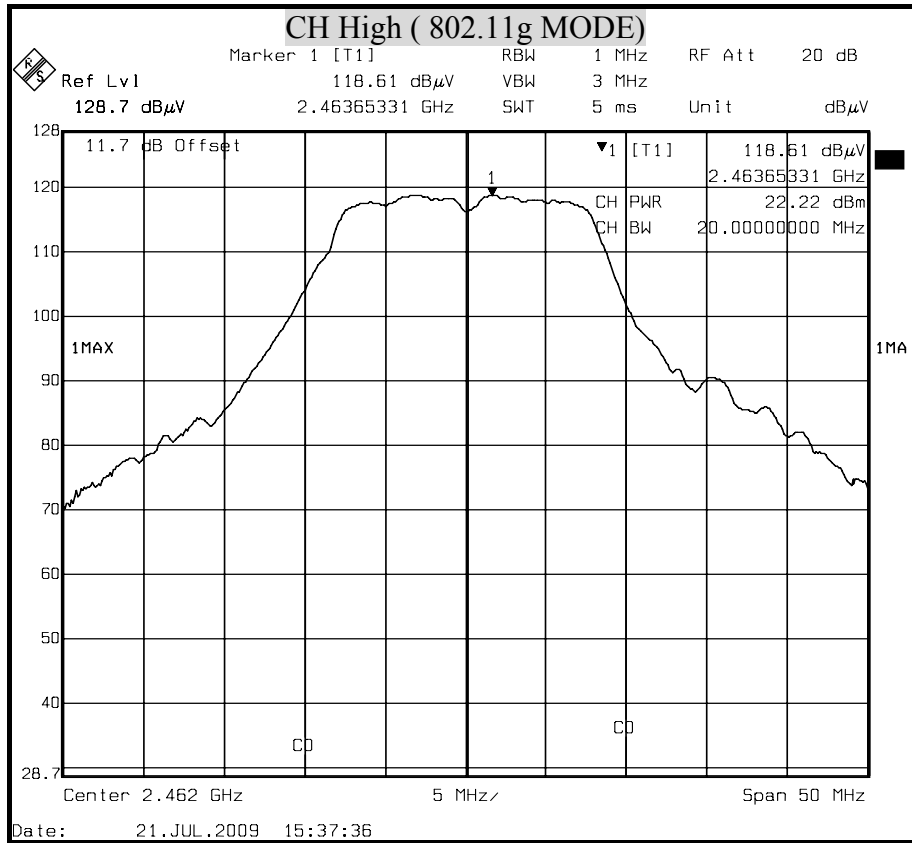



MAXIMUM PEAK OUTPUT POWER (802.11n HT20 MODE)

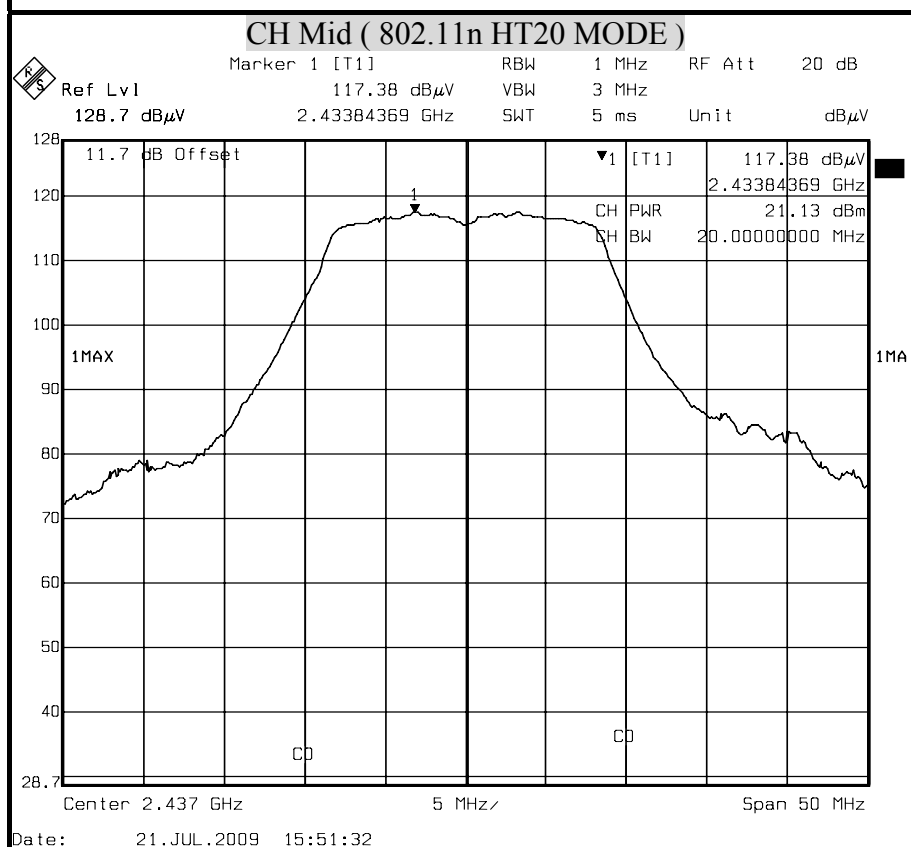
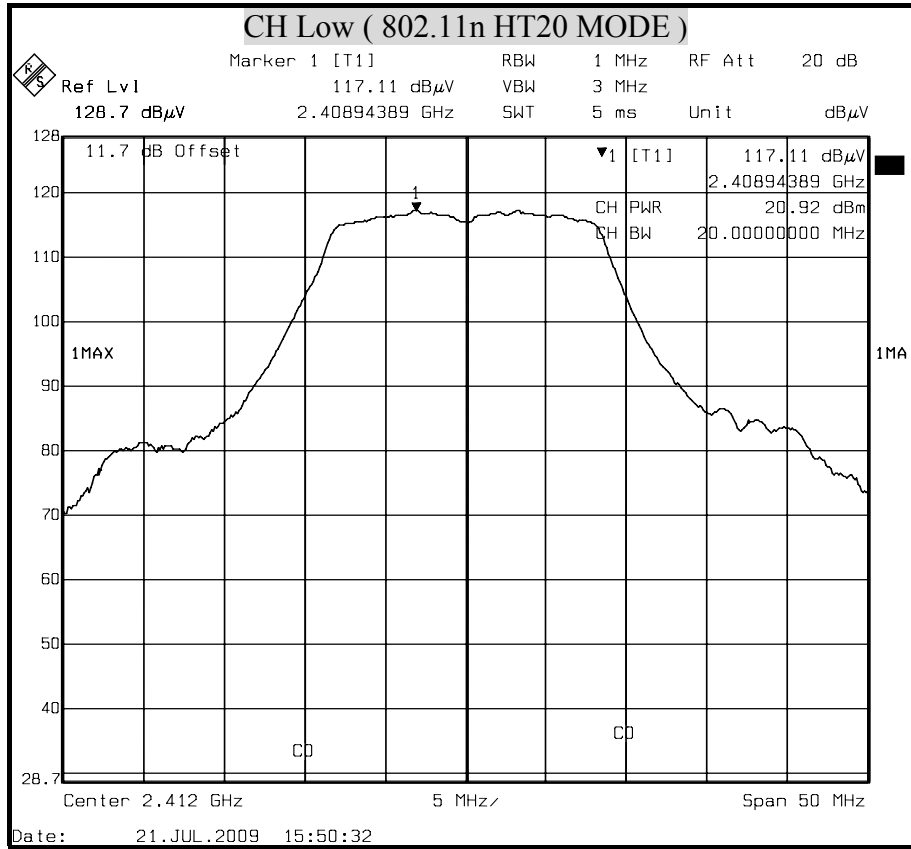

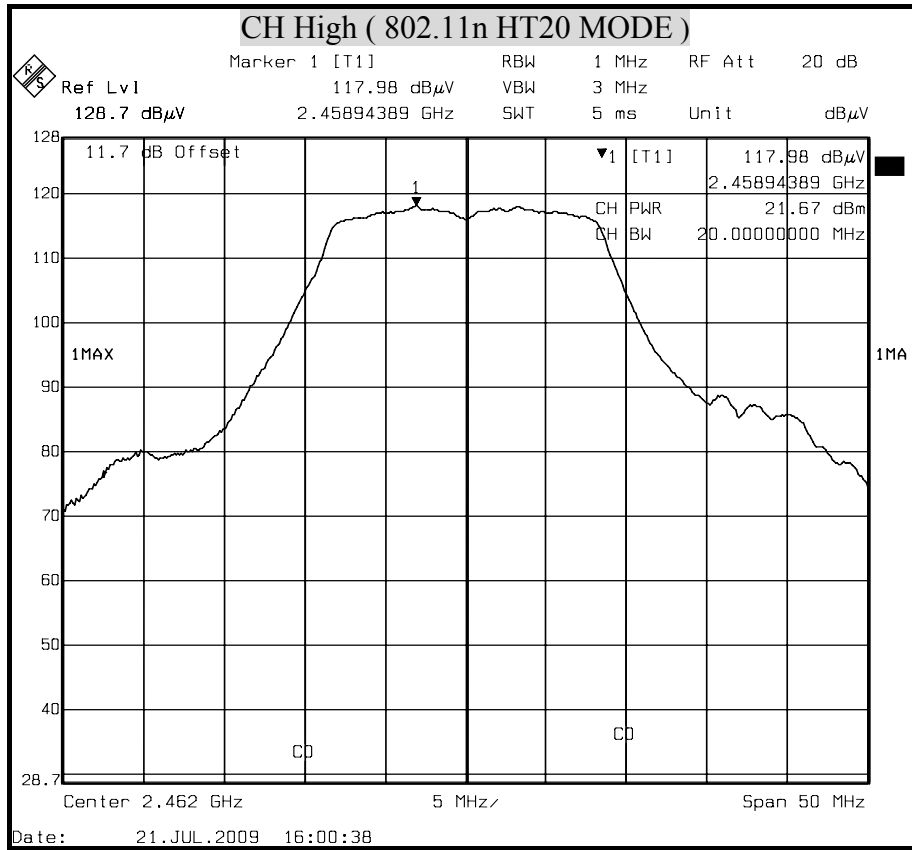



MAXIMUM PEAK OUTPUT POWER (802.11n HT40 MODE)

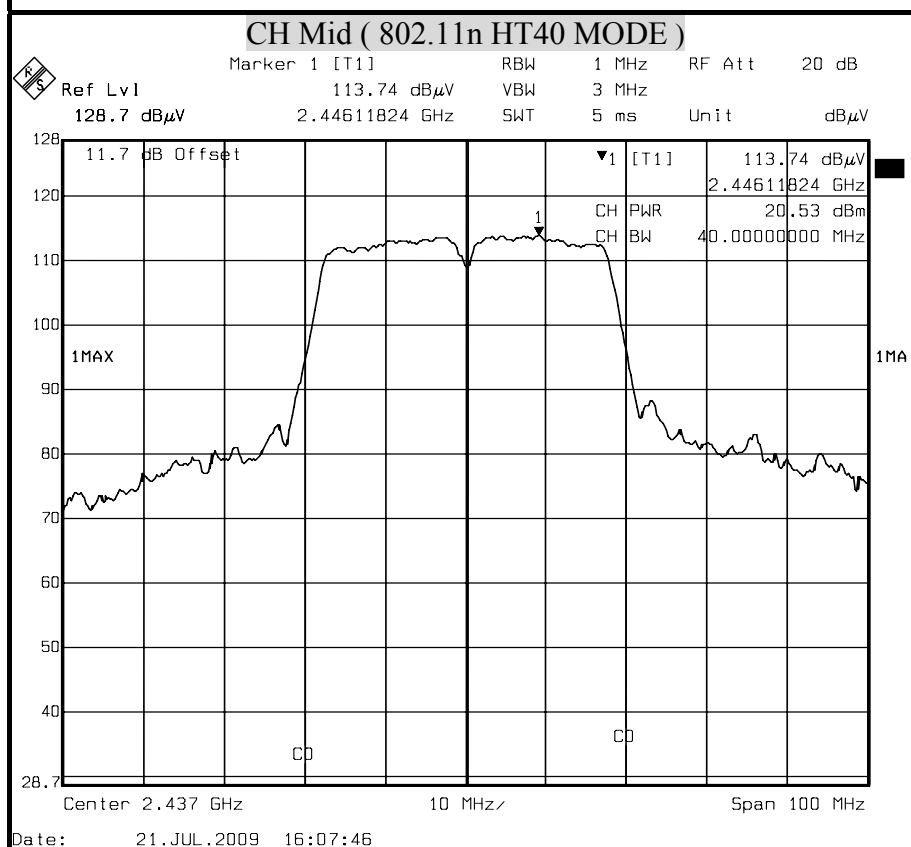
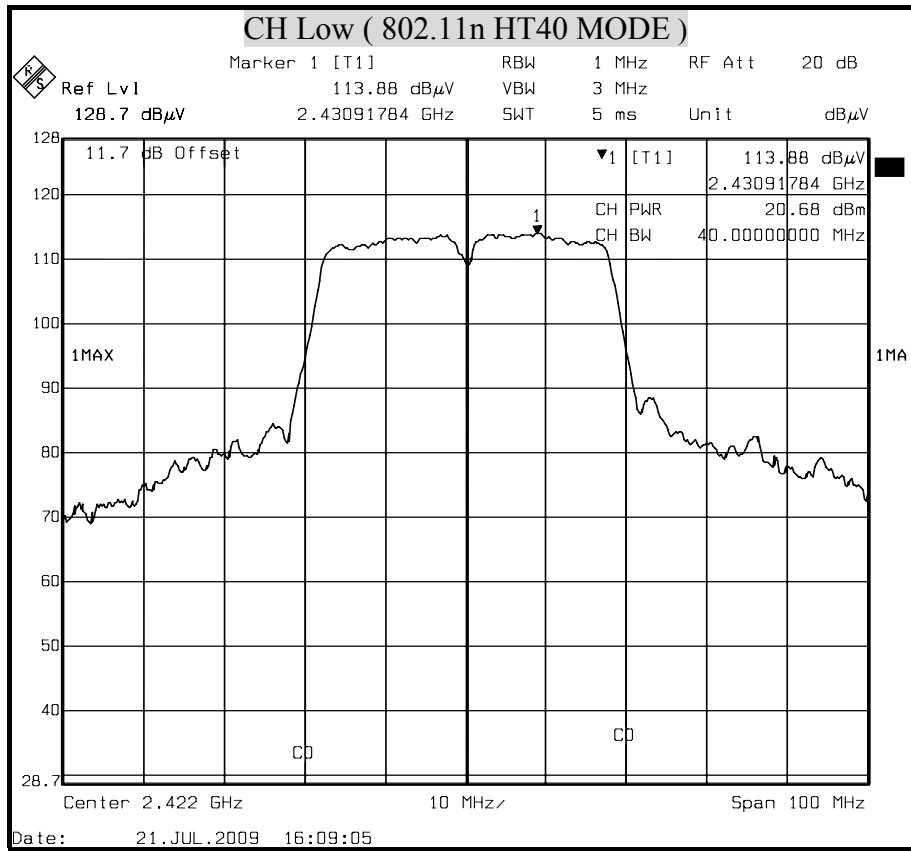

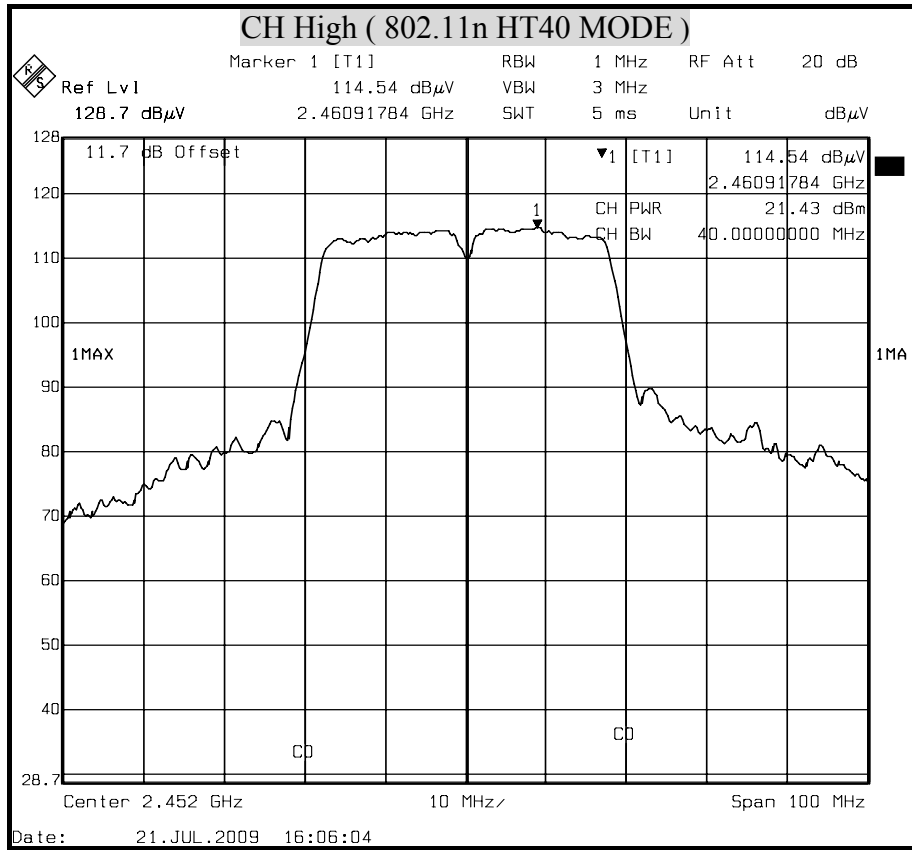

8.3 MAXIMUM PERMISSIBLE EXPOSURE

According to FCC 1.1310 : The criteria listed in the following table shall be used to evaluate the environment impact of human exposure to radio frequency (RF) radiation as specified in 1.1307(b) LIMITS FOR MAXIMUM PERMISSIBLE EXPOSURE (MPE)

Frequency Range (MHz)	Electric Field Strength (V/m)	Magnetic Field Strength (A/m)	Power Density (mW/cm ²)	Average Time
(A) Limits for Occupational / Control Exposures				
300-1,500	--	--	F/300	6
1,500-100,000	--	--	5	6
(B) Limits for General Population / Uncontrol Exposures				
300-1,500	--	--	F/1500	6
1,500-100,000	--	--	1	30

CALCULATIONS

Given $E = \frac{\sqrt{30 \times P \times G}}{d}$ & $S = \frac{E^2}{3770}$

Where $E =$ Field strength in Volts / meter

$P =$ Power in Watts

$G =$ Numeric antenna gain

$d =$ Distance in meters

$S =$ Power density in milliwatts / square centimeter

Combining equations and re-arranging the terms to express the distance as a function of the remaining variables yields:

$$S = \frac{30 \times P \times G}{3770d^2}$$

Changing to units of mW and cm, using:

$$P (mW) = P (W) / 1000 \text{ and}$$

$$d (cm) = d(m) / 100$$

Yields

$$S = \frac{30 \times (P/1000) \times G}{3770 \times (d/100)^2} = 0.0796 \times \frac{P \times G}{d^2}$$

Where $d =$ Distance in cm

$P =$ Power in mW

$G =$ Numeric antenna gain

$S =$ Power density in mW / cm²

**LIMIT**Power Density Limit, $S=1.0\text{mW}/\text{cm}^2$ **TEST RESULTS**

No non-compliance noted.

$$S = \frac{30 \times (P/1000) \times G}{3770 \times (d/100)^2} = 0.0796 \times \frac{P \times G}{d^2}$$

 $G=2.0\text{dBi}=1.58489319\text{dB}$ IEEE 80211b = $0.0796 \times 145.5459 \times 1.58489319 / 400 = 0.045904$ IEEE 80211g = $0.0796 \times 166.7247 \times 1.58489319 / 400 = 0.052584$ IEEE 802n HT20 = $0.0796 \times 146.8926 \times 1.58489319 / 400 = 0.046329$ IEEE 802n HT40 = $0.0796 \times 138.9953 \times 1.58489319 / 400 = 0.043838$

Mode	Minimum separation distance (cm)	Output Power (dBm)	Output Power (mw)	Antenna Gain (dBi)	Power Density Limit (mW/cm^2)	Power Density at 20cm (mW/cm^2)
IEEE 802.11b	20.0	21.63	145.55	2	1	0.045904
IEEE 802.11g	20.0	22.22	166.72	2	1	0.052584
IEEE 802.11n HT20	20.0	21.67	146.89	2	1	0.046329
IEEE 802.11n HT40	20.0	21.43	139.00	2	1	0.043838

REMARK: For mobile or fixed location transmitters, the maximum power density is $1.0 \text{ mW}/\text{cm}^2$ even if the calculation indicates that the power density would be larger.



8.4 POWER SPECTRAL DENSITY

LIMIT

§ 15.247(e) For digitally modulated systems, the power spectral density conducted from the intentional radiator to the antenna shall not greater than 8 dBm in any 3 kHz band during any time interval of continuous transmission.

TEST EQUIPMENTS

Name of Equipment	Manufacturer	Model	Serial Number	Calibration Due
Spectrum Analyzer	R&S	FSEK 30	835253/002	OCT. 14, 2009

TEST SETUP

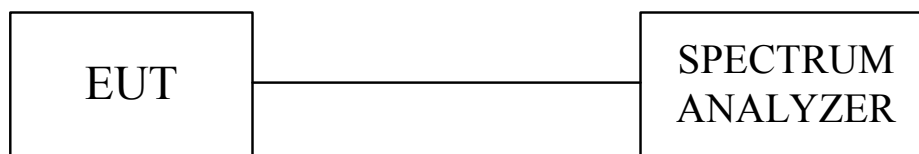

TEST PROCEDURE

The transmitter output was connected to the spectrum analyzer, the bandwidth of the fundamental frequency was measured with the spectrum analyzer using RBW=3KHz and VBW \geq RBW, set sweep time=span / 3KHz.

The power spectral density was measured and recorded.

The sweep time is allowed to be longer than span / 3KHz for a full response of the mixer in the spectrum analyzer.

TEST RESULTS

No non-compliance noted.

**IEEE 802.11b mode**

Channel	Channel Frequency (MHz)	Final RF Power Level in 3KHz BW (dBm)	Maximum Limit (dBm)	Pass / Fail
Low	2412	-12.67	8	PASS
Middle	2437	-11.99	8	PASS
High	2462	-11.53	8	PASS

NOTE : 1. At final test to get the worst-case emission at 11Mbps.
2. The cable assembly insertion loss of 11.7dB (including 10 dB pad and 1.7 dB cable) was Entered as an offset in the spectrum analyzer to allow for direct reading of power.

IEEE 802.11g mode

Channel	Channel Frequency (MHz)	Final RF Power Level in 3KHz BW (dBm)	Maximum Limit (dBm)	Pass / Fail
Low	2412	-16.50	8	PASS
Middle	2437	-16.08	8	PASS
High	2462	-15.14	8	PASS

NOTE : 1. At final test to get the worst-case emission at 6Mbps.
2. The cable assembly insertion loss of 11.7dB (including 10 dB pad and 1.7 dB cable) was Entered as an offset in the spectrum analyzer to allow for direct reading of power.

IEEE 802.11n HT20 mode

Channel	Channel Frequency (MHz)	Final RF Power Level in 3KHz BW (dBm)	Maximum Limit (dBm)	Pass / Fail
Low	2412	-16.58	8	PASS
Middle	2437	-16.05	8	PASS
High	2462	-14.91	8	PASS

NOTE : 1. At final test to get the worst-case emission at 6.5Mbps.
2. The cable assembly insertion loss of 11.7dB (including 10 dB pad and 1.7 dB cable) was Entered as an offset in the spectrum analyzer to allow for direct reading of power.

IEEE 802.11n HT40 mode

Channel	Channel Frequency (MHz)	Final RF Power Level in 3KHz BW (dBm)	Maximum Limit (dBm)	Pass / Fail
Low	2422	-19.62	8	PASS
Middle	2437	-19.59	8	PASS
High	2452	-18.92	8	PASS

NOTE : 1. At final test to get the worst-case emission at 13.5Mbps.
2. The cable assembly insertion loss of 11.7dB (including 10 dB pad and 1.7 dB cable) was Entered as an offset in the spectrum analyzer to allow for direct reading of power.



POWER SPECTRAL DENSITY (IEEE 802.11b MODE)

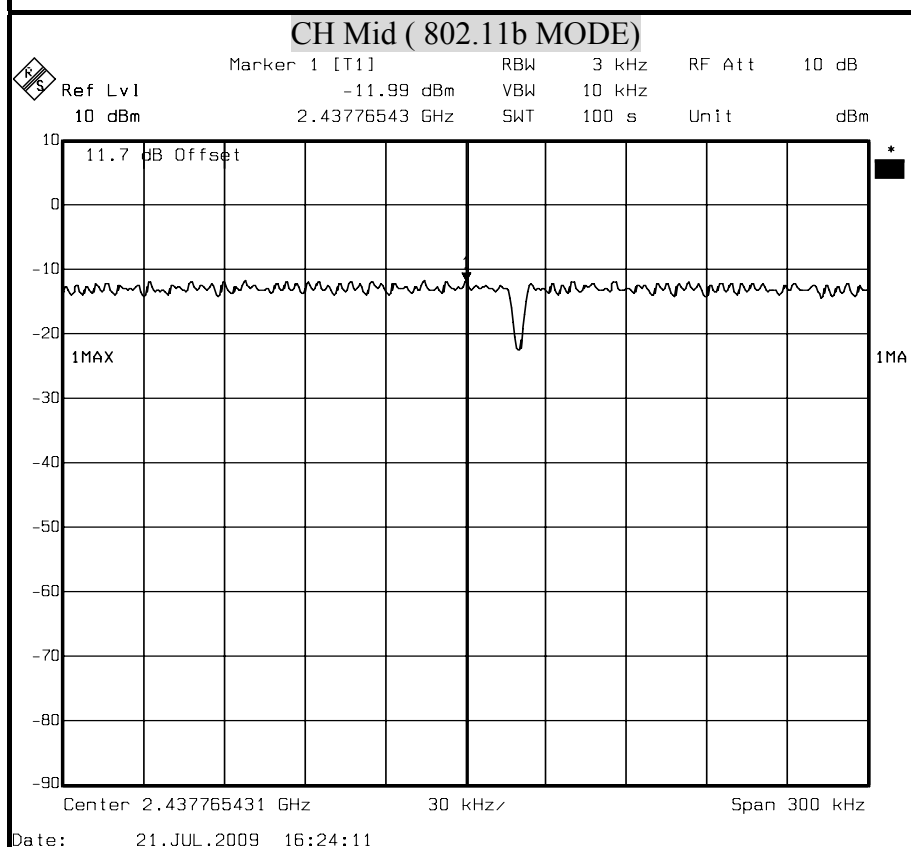
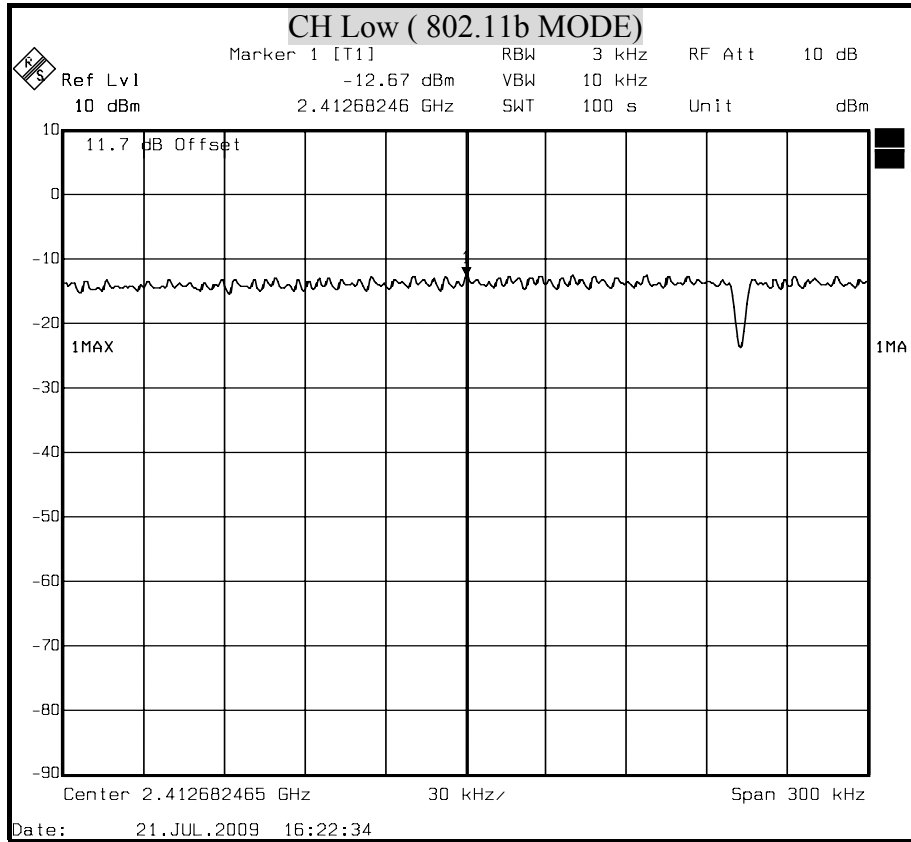

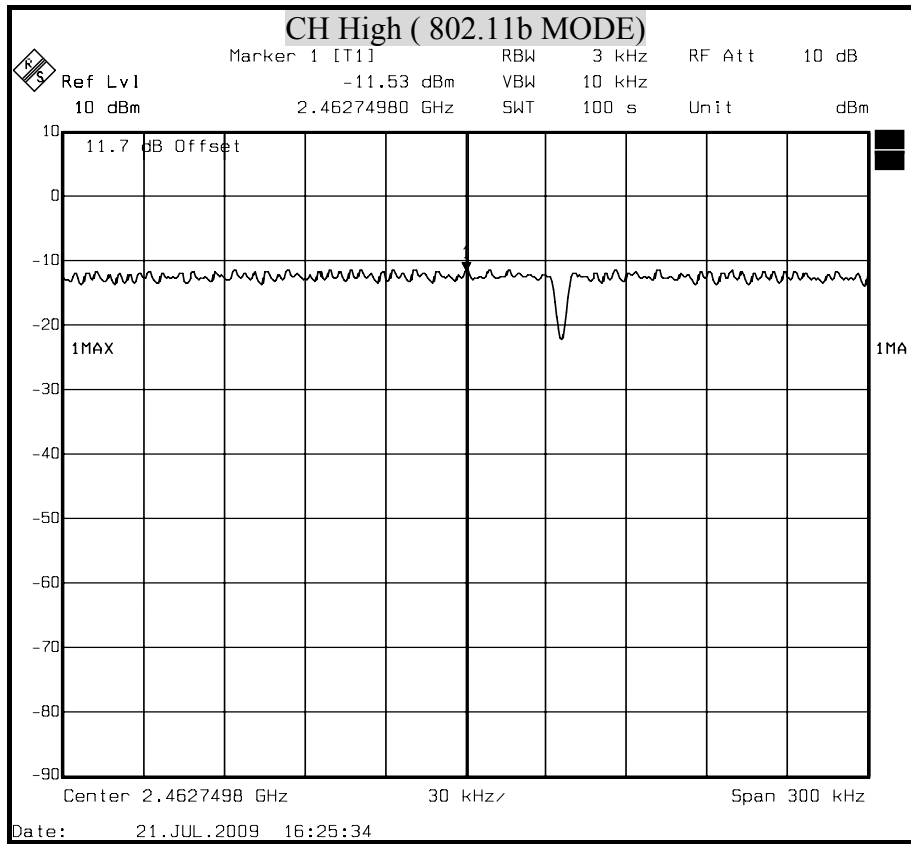



POWER SPECTRAL DENSITY (IEEE 802.11g MODE)

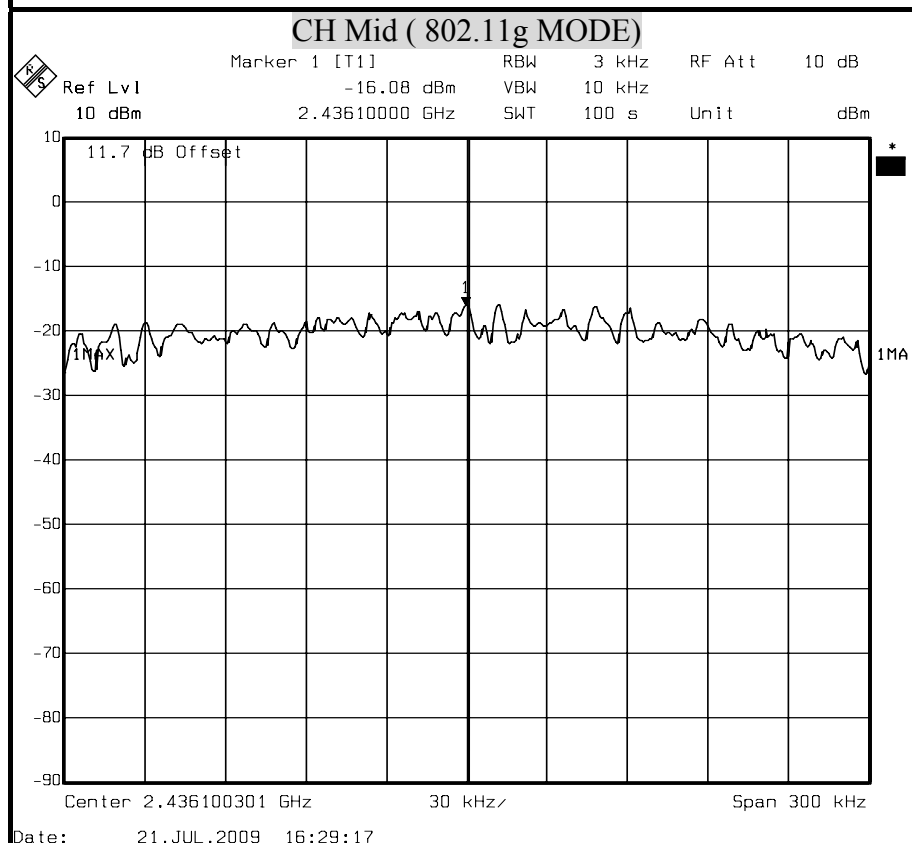
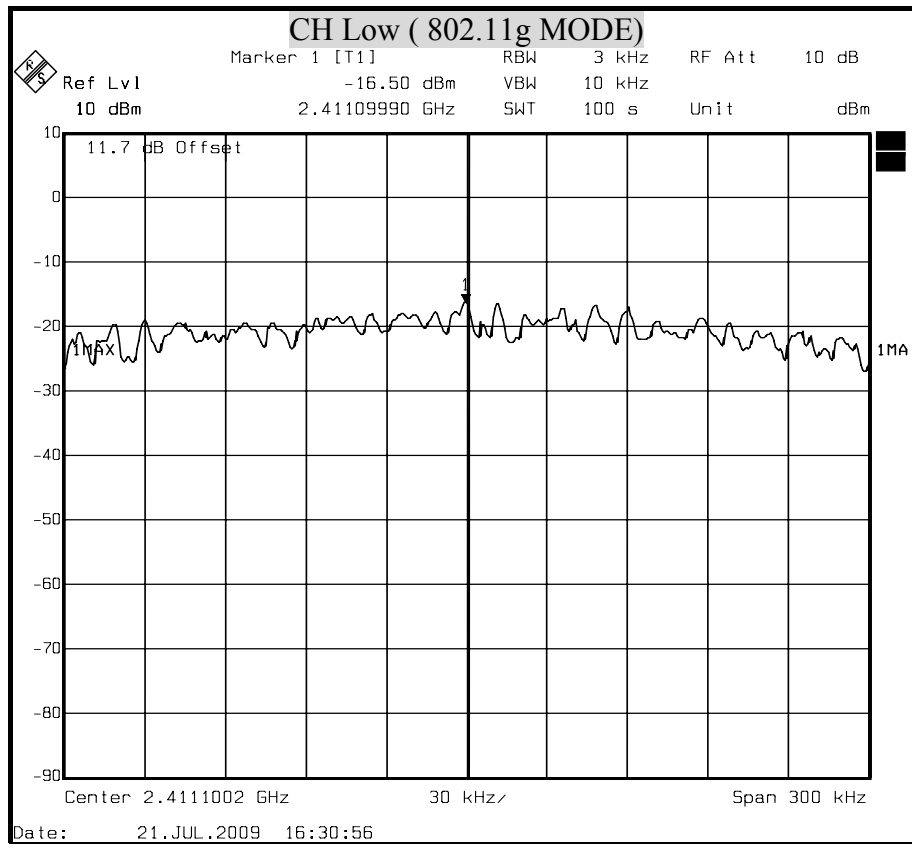

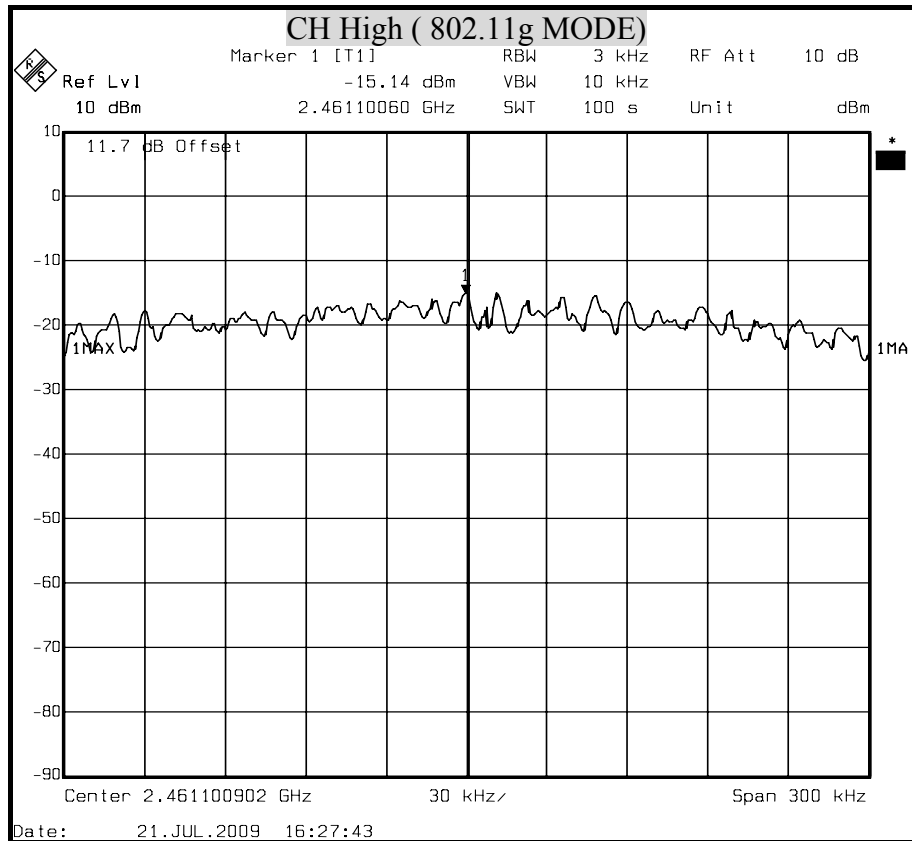



POWER SPECTRAL DENSITY (802.11n HT20 MODE)

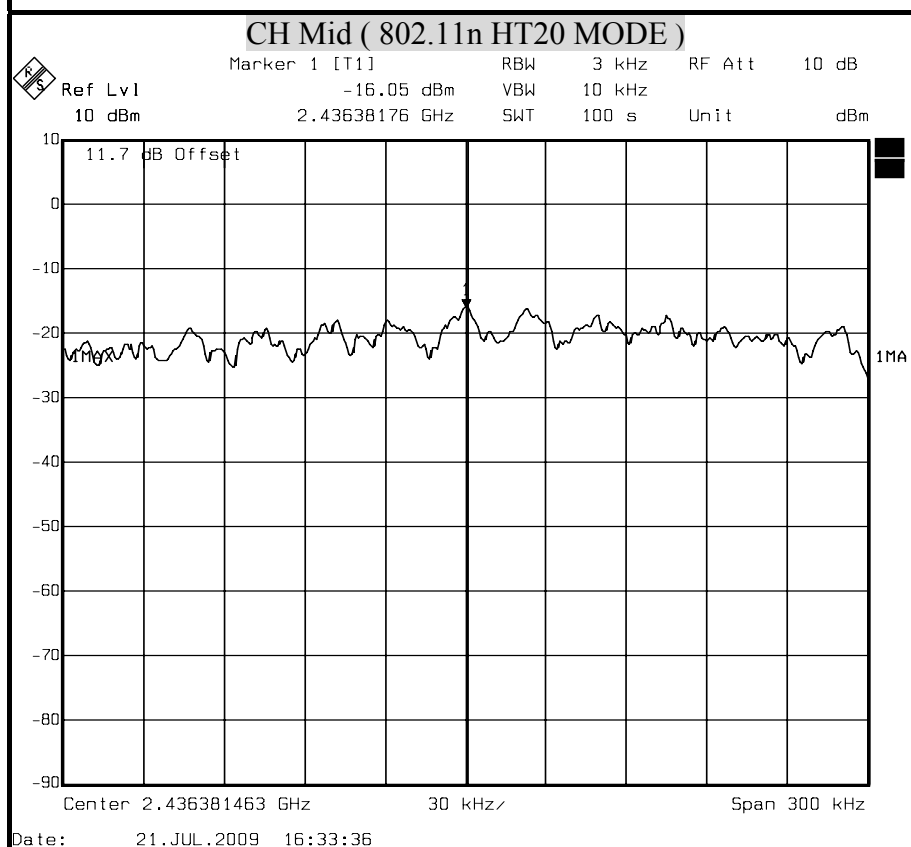
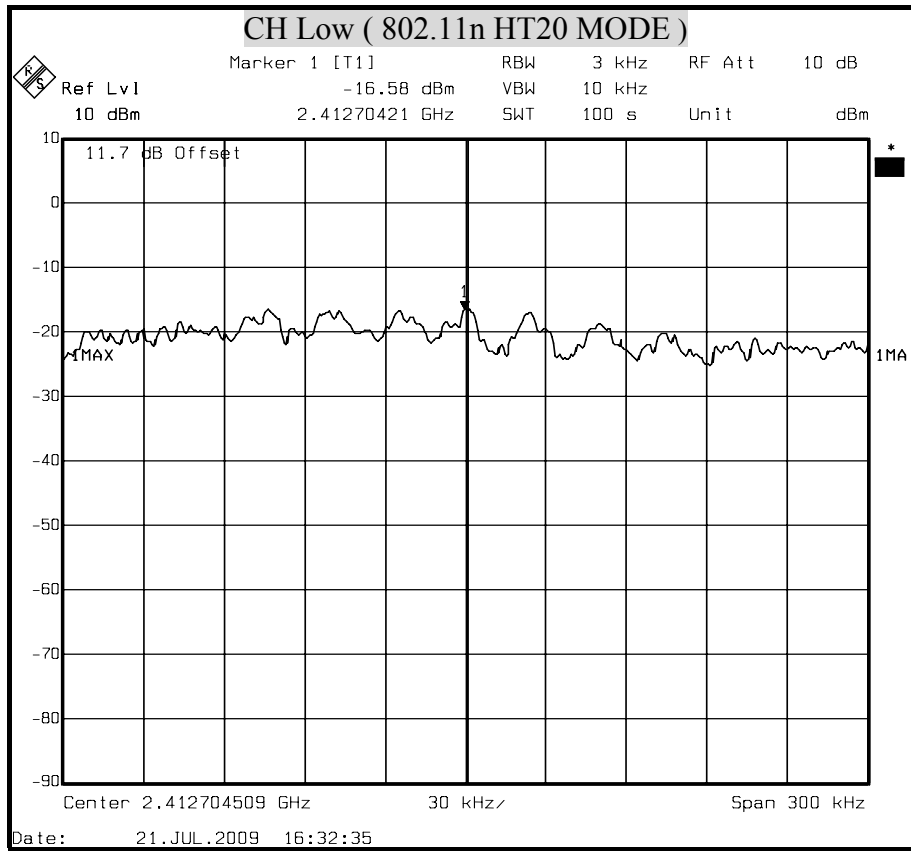

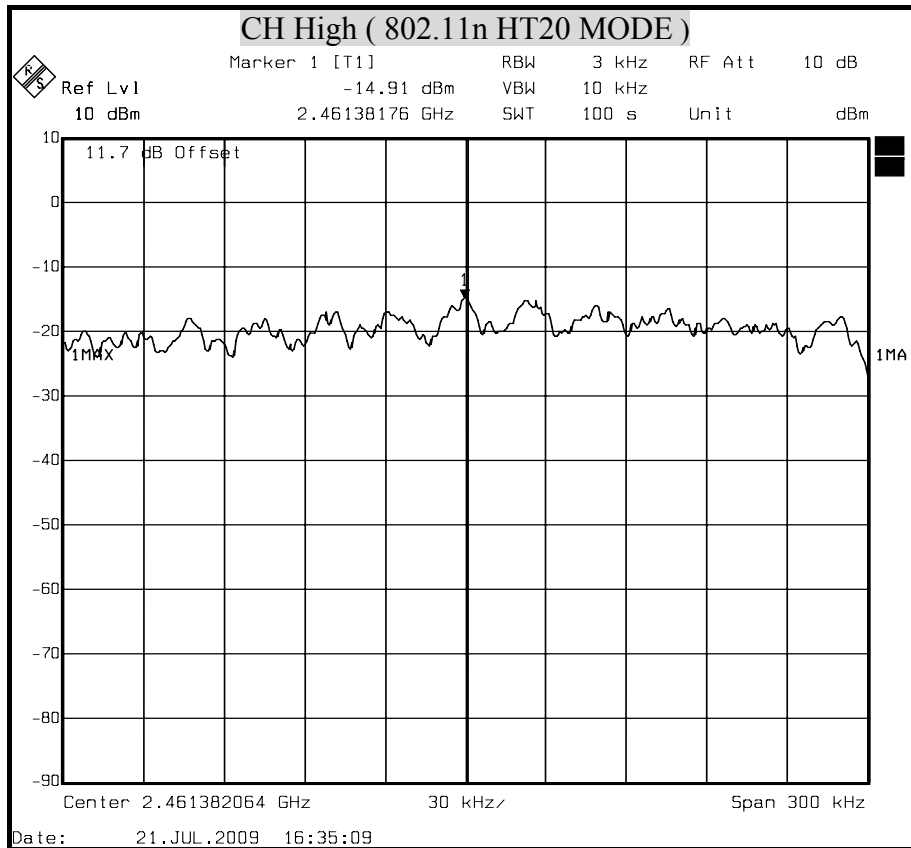



POWER SPECTRAL DENSITY (802.11n HT40 MODE)

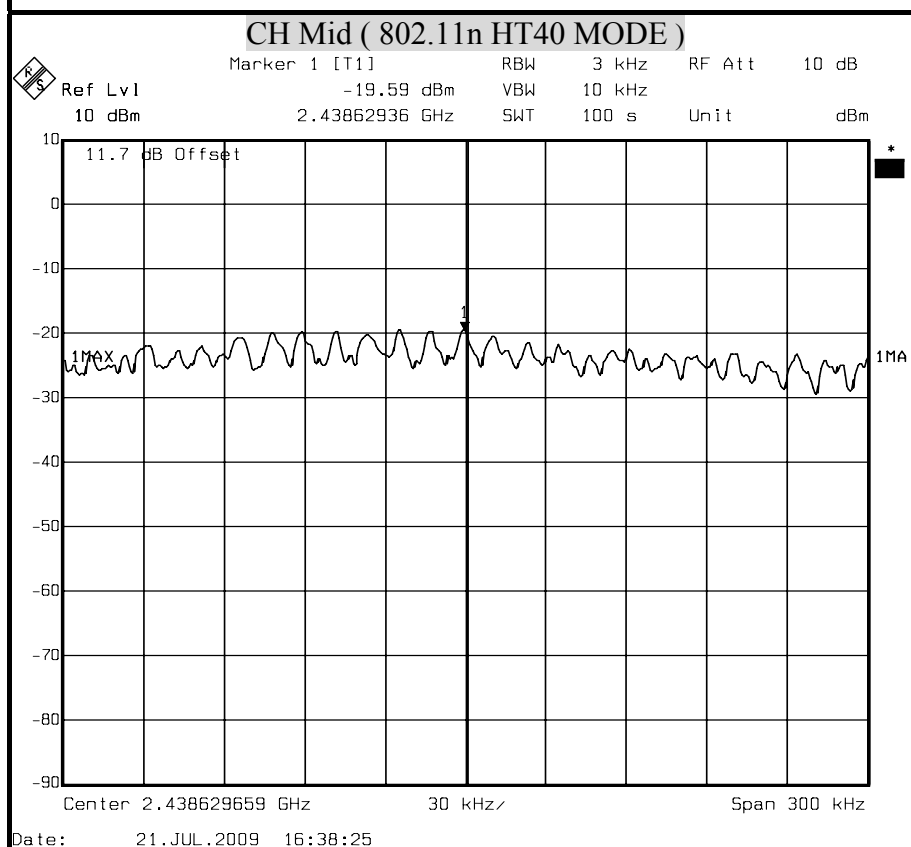
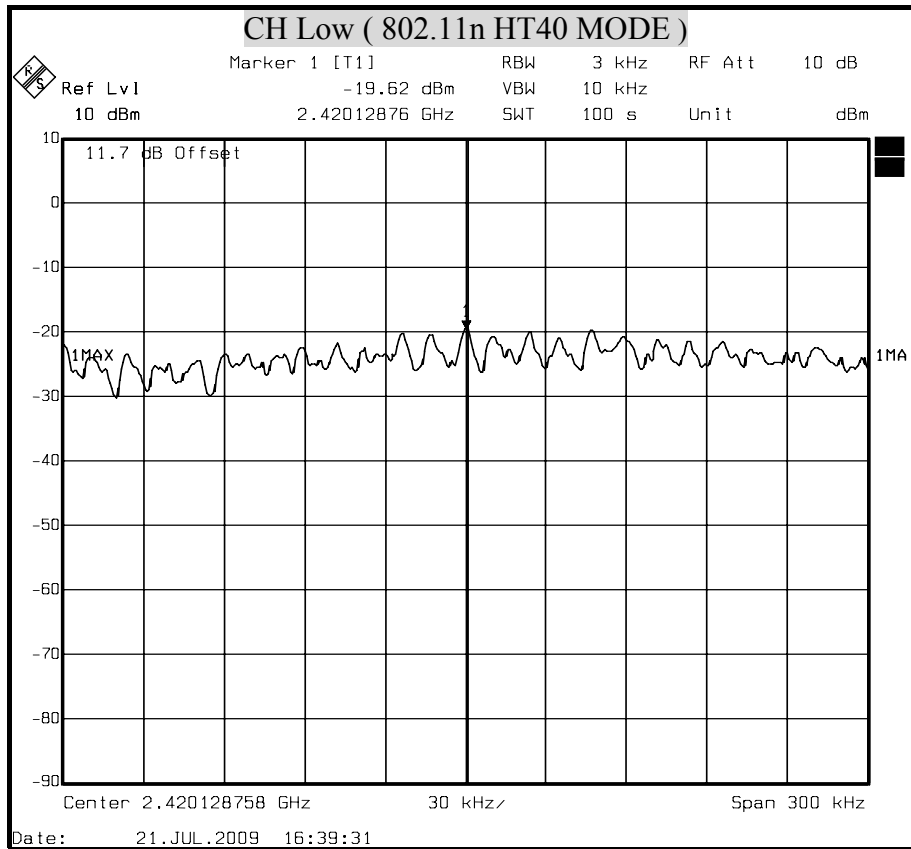

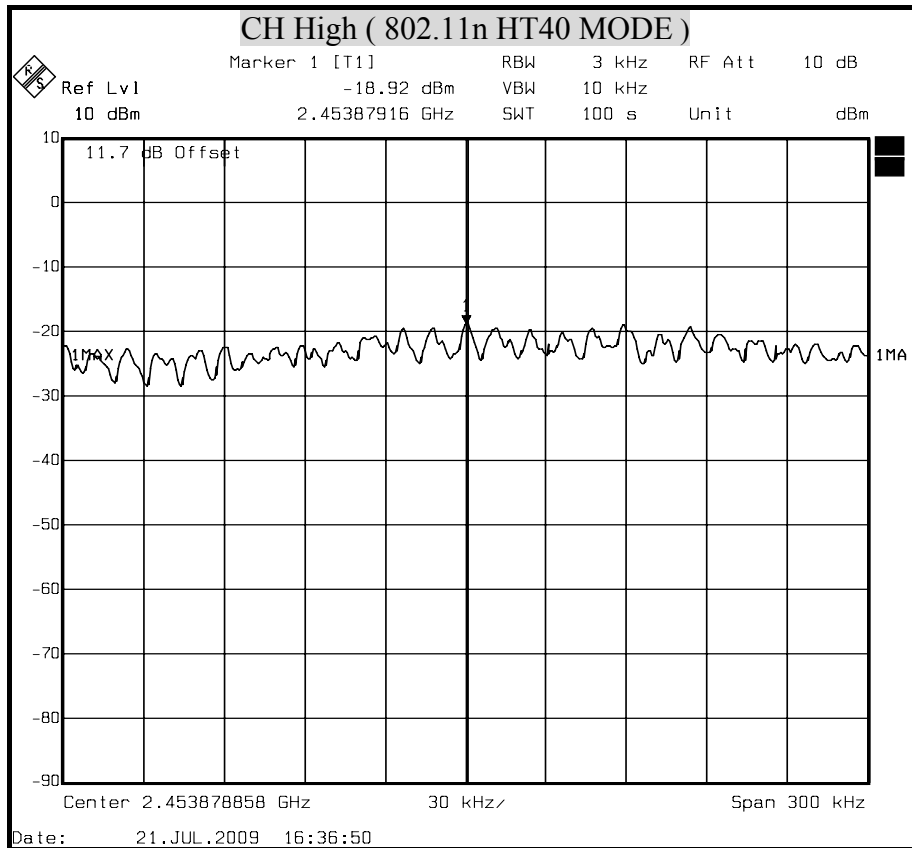

8.5 CONDUCTED SPURIOUS EMISSION

LIMITS

§ 15.247(d) In any 100 kHz bandwidth outside the frequency band in which the spread spectrum intentional radiator is operating, the radio frequency power that is produced by the intentional radiator shall be at least 20 dB below that in the 100 kHz bandwidth within the band that contains the highest level of the desired power, based on either an RF conducted or a radiated measurement. Attenuation below the general limits specified in § 15.209(a) is not required. In addition, radiated emissions which fall in the restricted bands, as defined in § 15.205(a), must also comply with the radiated emission limits specified in § 15.209(a) (see § 15.205(c)).

TEST PROCEDURE

The transmitter output is connected to a spectrum analyzer. The resolution bandwidth is set to 100 kHz. The video bandwidth is set to 100 kHz.

The spectrum from 30 MHz to 26.5 GHz is investigated with the transmitter set to the lowest, middle, and highest channels in the 2.4 GHz band.

TEST SETUP

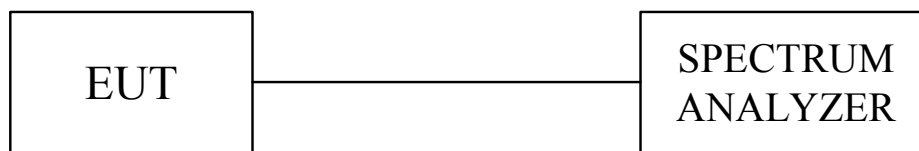

TEST RESULTS

No non-compliance noted.

**TEST DATA****IEEE 802.11b mode****Low**

Frequency	Offset	Reading	Level	Limit	Margin	Pass/Fail
(MHz)	(dB)	(dBμV)	(dBμV)	(dBμV)	(dB)	
2412.6352	11.7	100.71	112.41	N/A	N/A	--
2098.7976	11.7	46.25	57.95	92.41	-34.46	PASS
4804.1483	11.7	48.74	60.44	92.41	-31.97	PASS
23688.5571	11.7	49.93	61.63	92.41	-30.78	PASS

Mid

Frequency	Offset	Reading	Level	Limit	Margin	Pass/Fail
(MHz)	(dB)	(dBμV)	(dBμV)	(dBμV)	(dB)	
2436.2565	11.7	99.75	111.45	N/A	N/A	--
2098.7976	11.7	46.34	58.04	91.45	-33.41	PASS
4857.1943	11.7	47.41	59.11	91.45	-32.34	PASS
24272.0641	11.7	49.67	61.37	91.45	-30.08	PASS

High

Frequency	Offset	Reading	Level	Limit	Margin	Pass/Fail
(MHz)	(dB)	(dBμV)	(dBμV)	(dBμV)	(dB)	
2462.5983	11.7	100.51	112.21	N/A	N/A	--
2151.8436	11.7	47.24	58.94	92.21	-33.27	PASS
4910.2404	11.7	45.96	57.66	92.21	-34.55	PASS
23953.7875	11.7	48.46	60.16	92.21	-32.05	PASS

**IEEE 802.11g mode****Low**

Frequency	Offset	Reading	Level	Limit	Margin	Pass/Fail
(MHz)	(dB)	(dBμV)	(dBμV)	(dBμV)	(dB)	
2412.6538	11.7	92.45	104.15	N/A	N/A	--
2098.7976	11.7	43.20	54.9	84.15	-29.25	PASS
6660.7615	11.7	42.35	54.05	84.15	-30.10	PASS
24219.018	11.7	48.80	60.5	84.15	-23.65	PASS

Mid

Frequency	Offset	Reading	Level	Limit	Margin	Pass/Fail
(MHz)	(dB)	(dBμV)	(dBμV)	(dBμV)	(dB)	
2436.5239	11.7	93.28	104.98	N/A	N/A	--
2151.8436	11.7	41.76	53.46	84.98	-31.52	PASS
6979.038	11.7	42.07	53.77	84.98	-31.21	PASS
24272.0641	11.7	50.04	61.74	84.98	-23.24	PASS

High

Frequency	Offset	Reading	Level	Limit	Margin	Pass/Fail
(MHz)	(dB)	(dBμV)	(dBμV)	(dBμV)	(dB)	
2461.8563	11.7	93.92	105.62	N/A	N/A	--
2151.8436	11.7	42.37	54.07	85.62	-31.55	PASS
6925.9919	11.7	42.07	53.77	85.62	-31.85	PASS
24325.1102	11.7	49.54	61.24	85.62	-24.38	PASS

**IEEE 802.1120 mode****Low**

Frequency	Offset	Reading	Level	Limit	Margin	Pass/Fail
(MHz)	(dB)	(dBμV)	(dBμV)	(dBμV)	(dB)	
2412.3526	11.7	92.07	103.77	N/A	N/A	--
2098.7976	11.7	43.01	54.71	83.77	-29.06	PASS
6766.8537	11.7	42.15	53.85	83.77	-29.92	PASS
23688.5571	11.7	49.34	61.04	83.77	-22.73	PASS

Mid

Frequency	Offset	Reading	Level	Limit	Margin	Pass/Fail
(MHz)	(dB)	(dBμV)	(dBμV)	(dBμV)	(dB)	
2436.5263	11.7	92.17	103.87	N/A	N/A	--
2098.7976	11.7	42.31	54.01	83.87	-29.86	PASS
6607.7154	11.7	42.22	53.92	83.87	-29.95	PASS
24325.1102	11.7	49.43	61.13	83.87	-22.74	PASS

High

Frequency	Offset	Reading	Level	Limit	Margin	Pass/Fail
(MHz)	(dB)	(dBμV)	(dBμV)	(dBμV)	(dB)	
2462.3524	11.7	93.29	104.99	N/A	N/A	--
2151.8436	11.7	42.92	54.62	84.99	-30.37	PASS
6713.8076	11.7	41.83	53.53	84.99	-31.46	PASS
23794.6493	11.7	49.56	61.26	84.99	-23.73	PASS

**IEEE 802.1140 mode****Low**

Frequency	Offset	Reading	Level	Limit	Margin	Pass/Fail
(MHz)	(dB)	(dBμV)	(dBμV)	(dBμV)	(dB)	
2422.6352	11.7	92.34	104.04	N/A	N/A	--
2151.8436	11.7	42.84	54.54	84.04	-29.50	PASS
6979.038	11.7	42.81	54.51	84.04	-29.53	PASS
24165.9719	11.7	50.28	61.98	84.04	-22.06	PASS

Mid

Frequency	Offset	Reading	Level	Limit	Margin	Pass/Fail
(MHz)	(dB)	(dBμV)	(dBμV)	(dBμV)	(dB)	
2436.5248	11.7	92.34	104.04	N/A	N/A	--
2151.8436	11.7	42.84	54.54	84.04	-29.50	PASS
7668.6372	11.7	42.33	54.03	84.04	-30.01	PASS
24219.018	11.7	49.55	61.25	84.04	-22.79	PASS

High

Frequency	Offset	Reading	Level	Limit	Margin	Pass/Fail
(MHz)	(dB)	(dBμV)	(dBμV)	(dBμV)	(dB)	
2452.5873	11.7	93.40	105.1	N/A	N/A	--
2151.8436	11.7	43.41	55.11	85.10	-29.99	PASS
7350.3607	11.7	41.46	53.16	85.10	-31.94	PASS
24219.018	11.7	49.30	61	85.10	-24.10	PASS



OUT-OF-BAND SPURIOUS EMISSIONS-CONDUCTED MEASUREMENT

(IEEE 802.11b MODE)

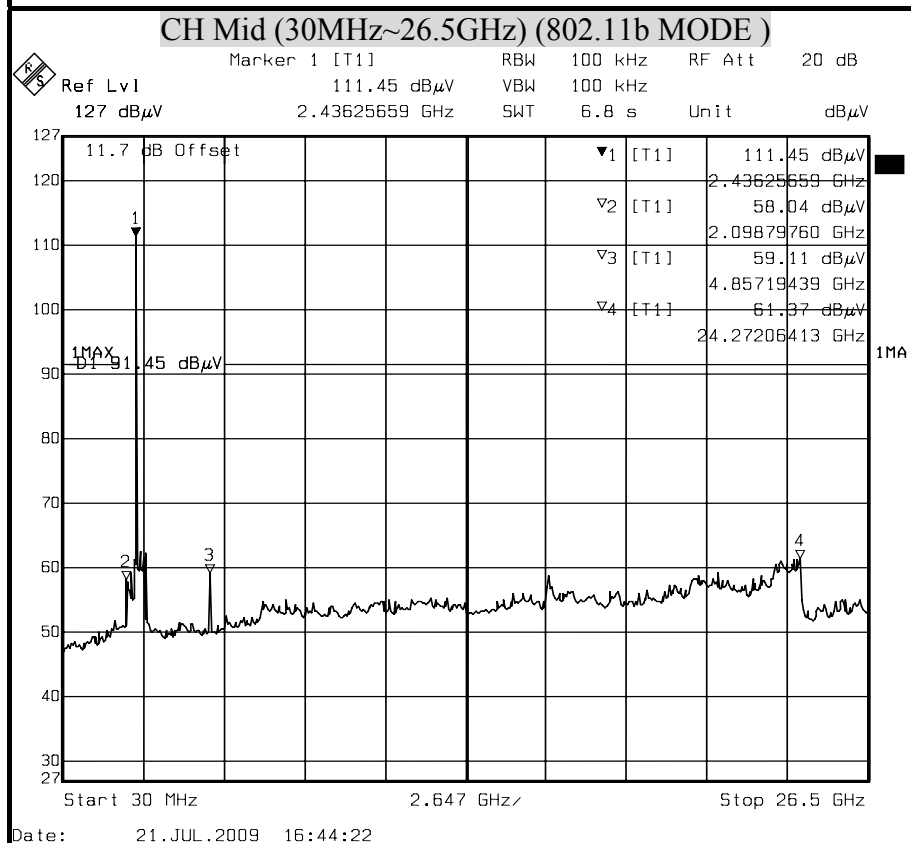
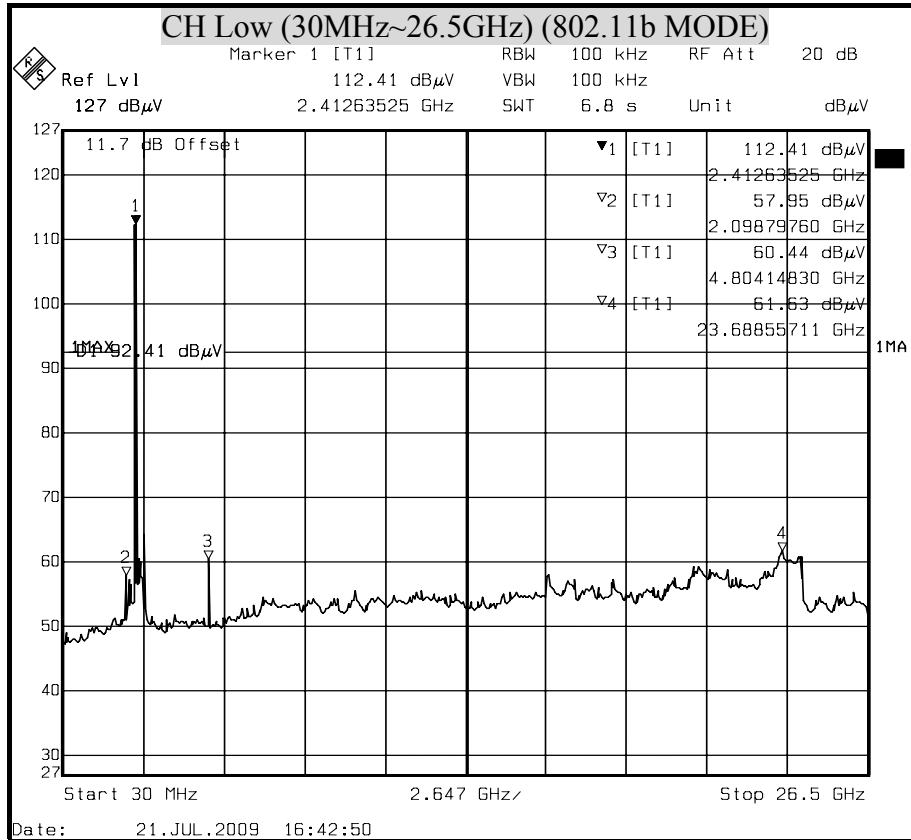

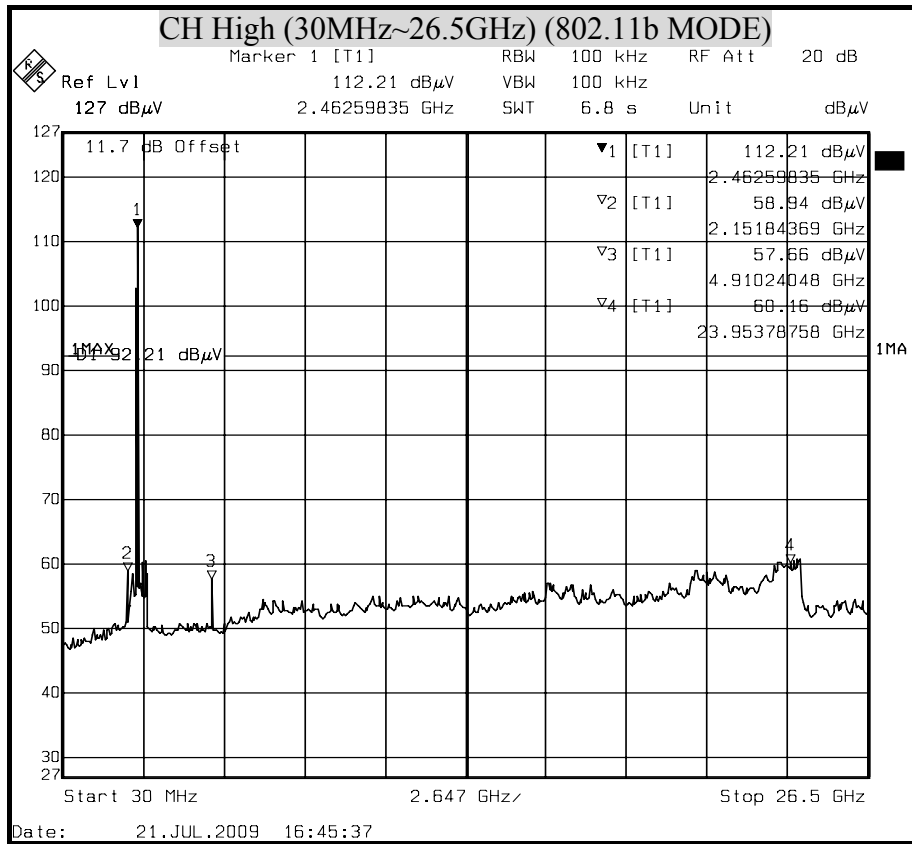



OUT-OF-BAND SPURIOUS EMISSIONS-CONDUCTED MEASUREMENT

(802.11g MODE)

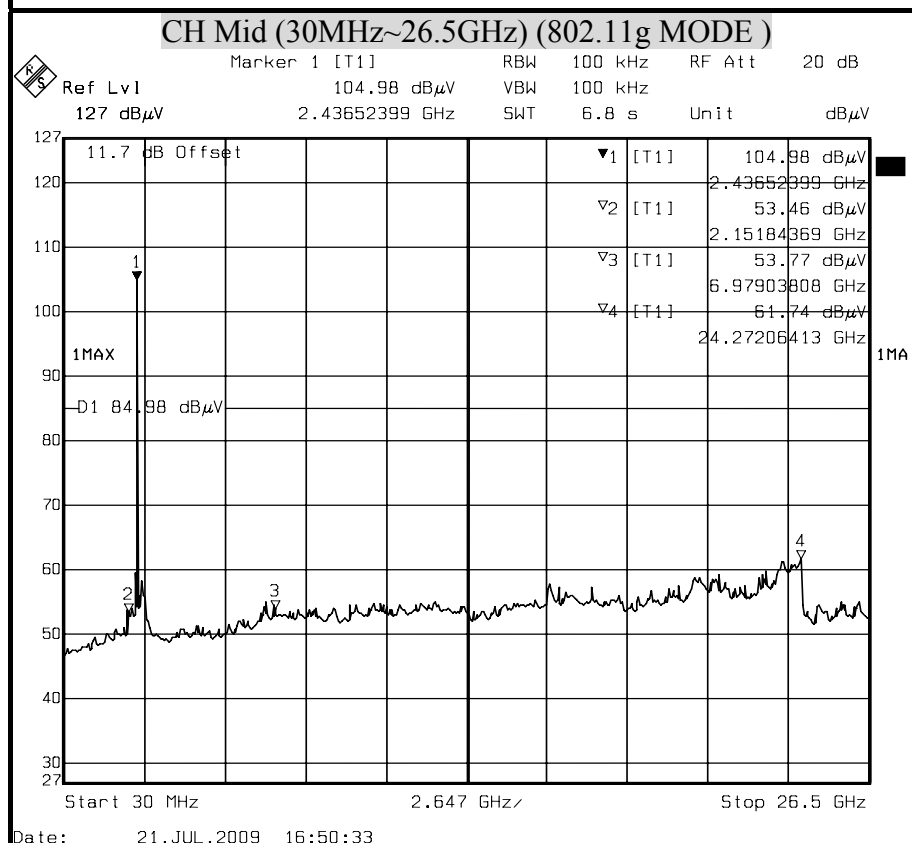
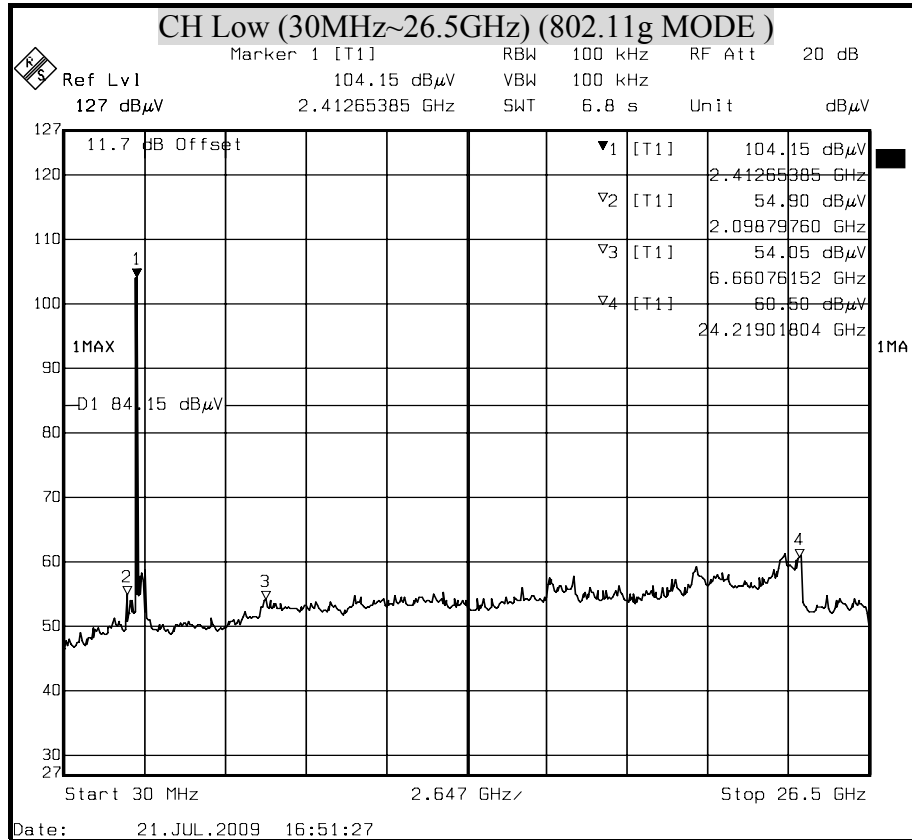

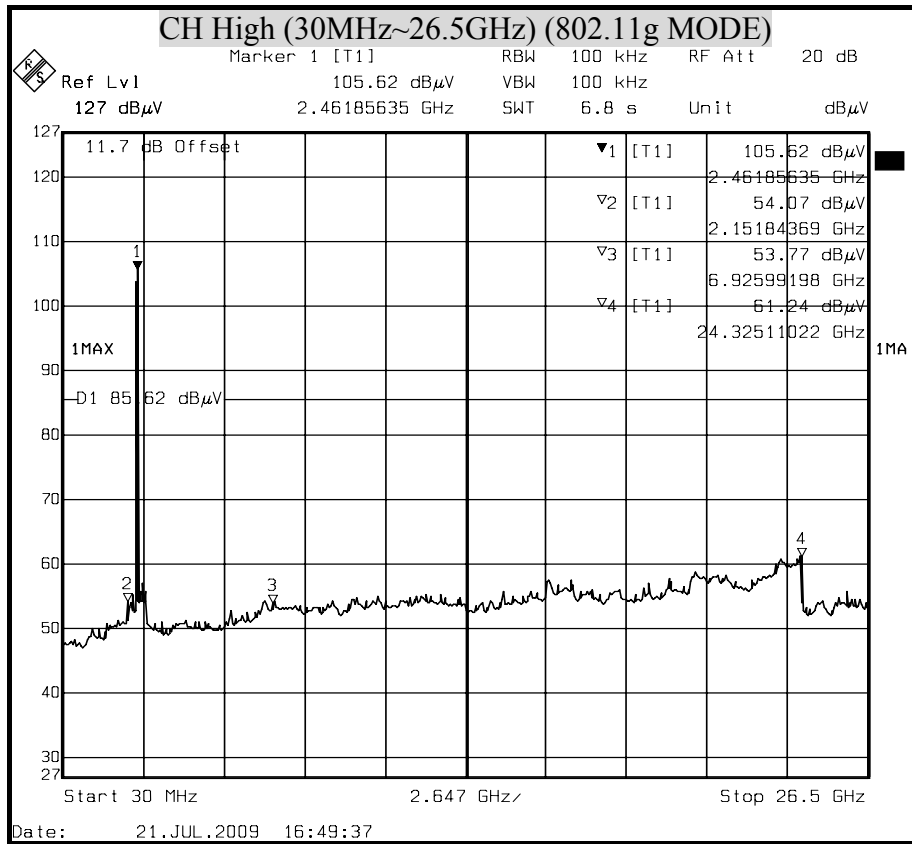



OUT-OF-BAND SPURIOUS EMISSIONS-CONDUCTED MEASUREMENT

(802.11n HT20 MODE)

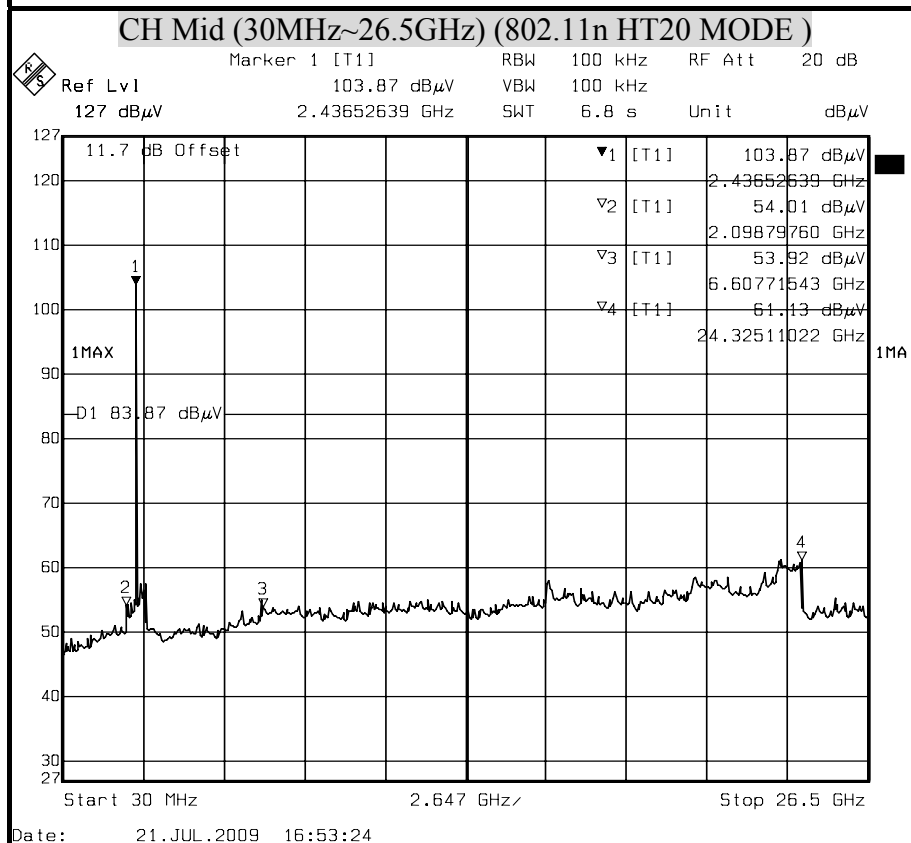
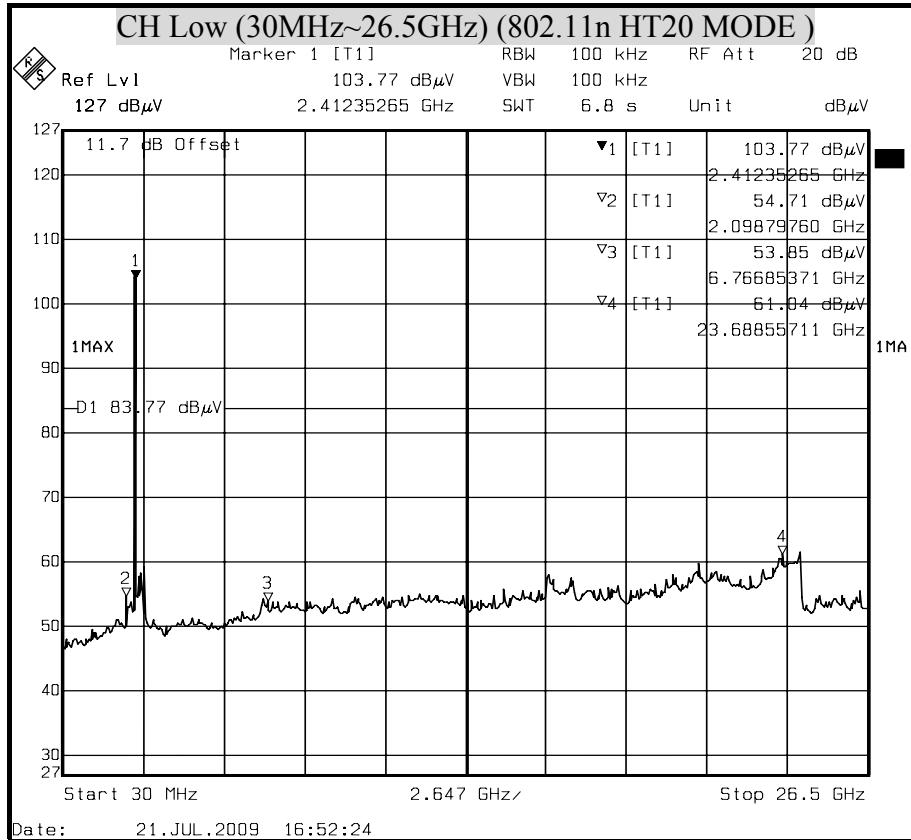

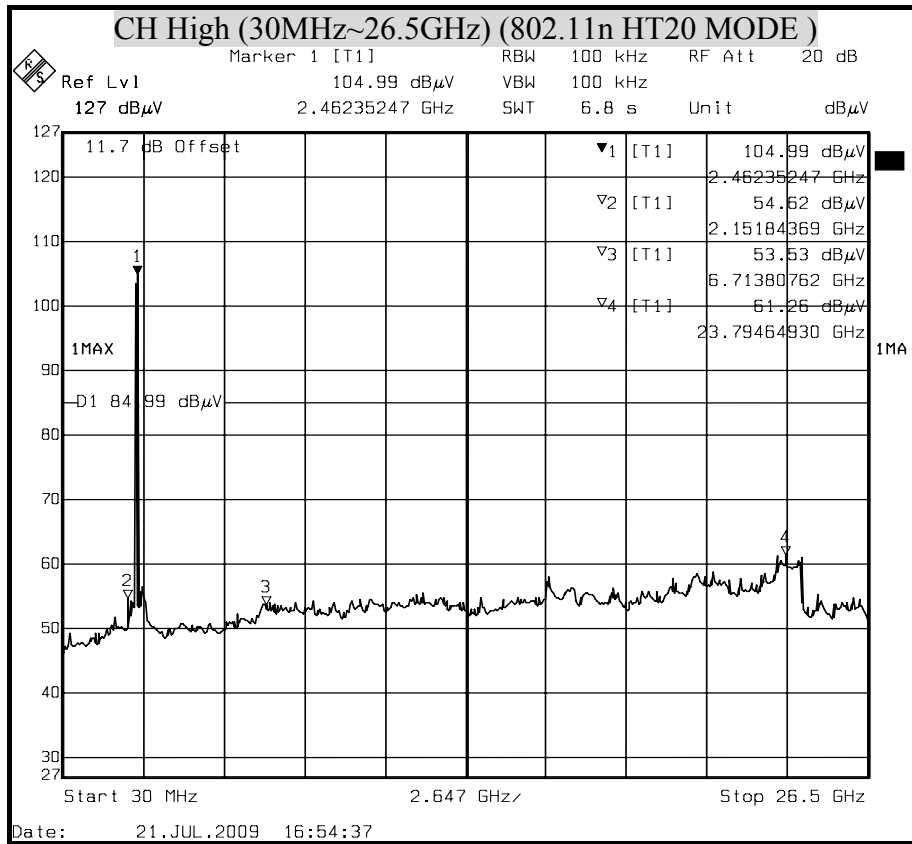



OUT-OF-BAND SPURIOUS EMISSIONS-CONDUCTED MEASUREMENT

(802.11n HT40 MODE)

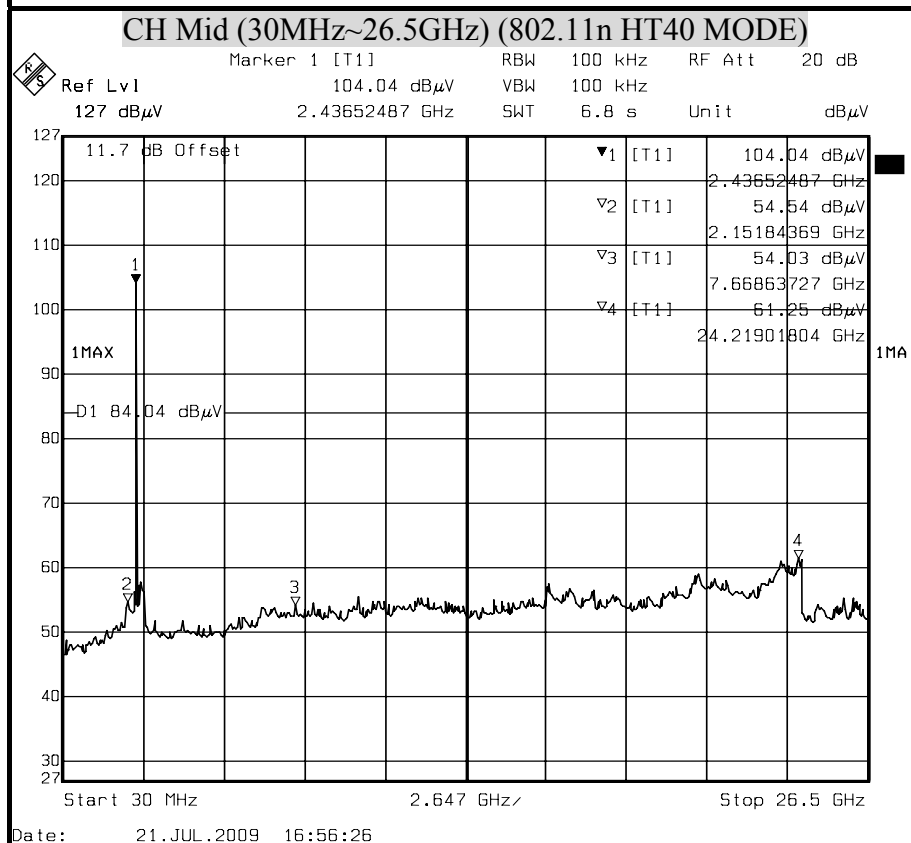
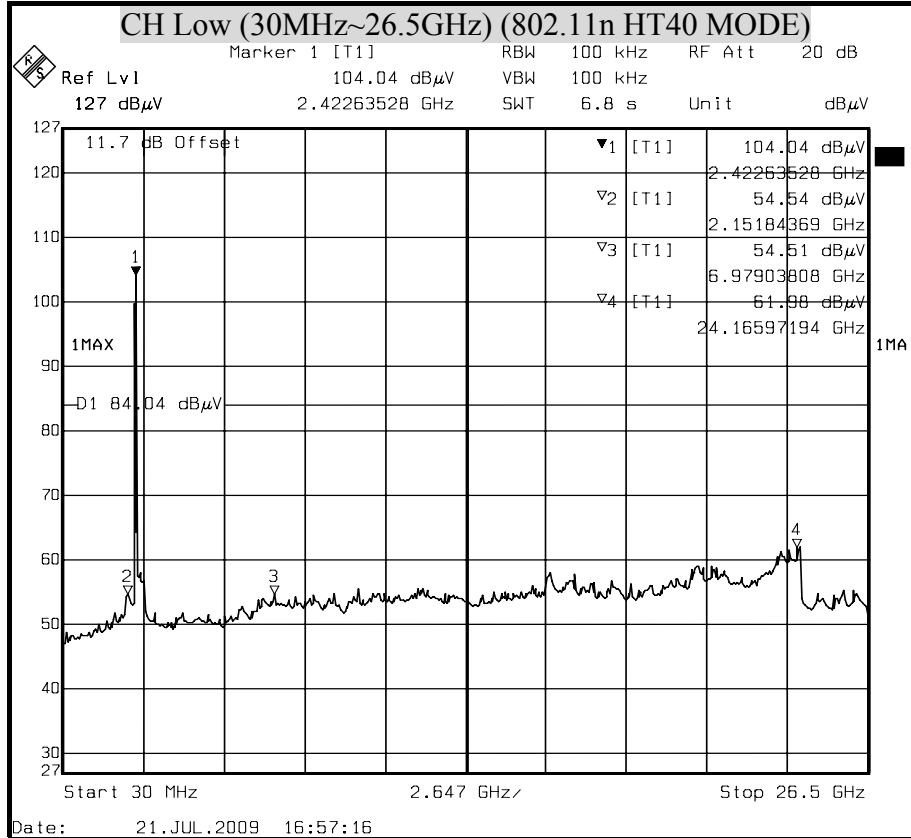

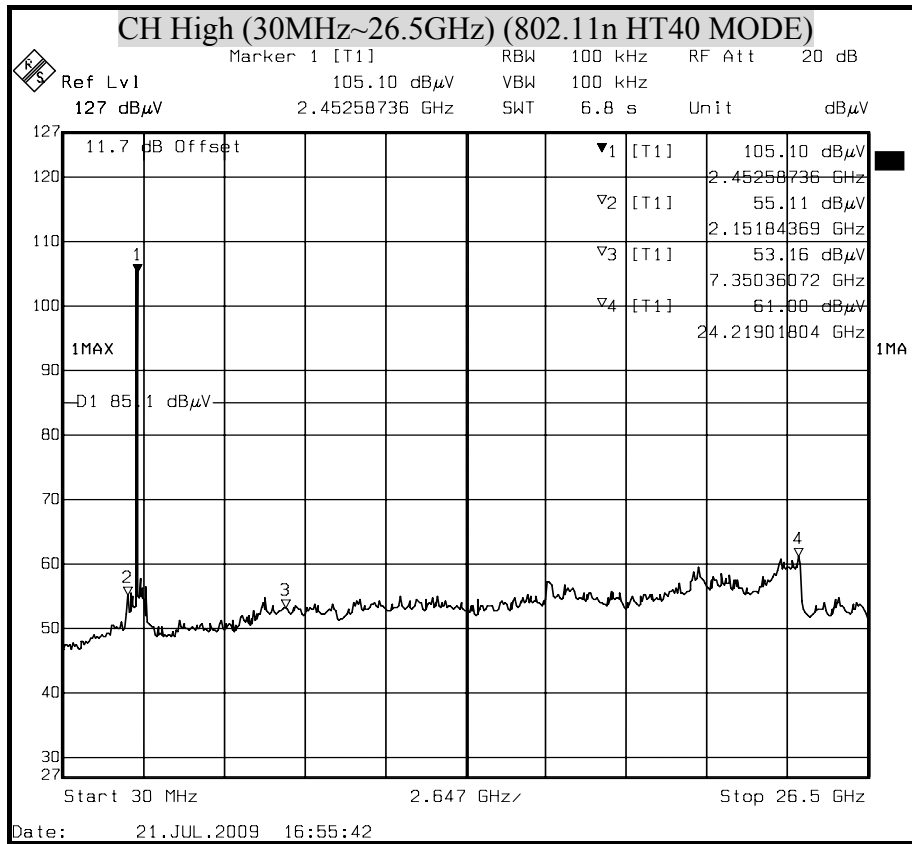



8.6 RADIATED EMISSIONS

8.6.1 TRANSMITTER RADIATED SUPURIOUS EMSSIONS

LIMITS

§ 15.205 (a) Except as shown in paragraph (d) of this section, only spurious emissions are permitted in any of the frequency bands listed below:

MHz	MHz	MHz	GHz
0.090 - 0.110	16.42 - 16.423	399.9 - 410	4.5 - 5.15
¹ 0.495 - 0.505	16.69475 - 16.69525	608 - 614	5.35 - 5.46
2.1735 - 2.1905	16.80425 - 16.80475	960 - 1240	7.25 - 7.75
4.125 - 4.128	25.5 - 25.67	1300 - 1427	8.025 - 8.5
4.17725 - 4.17775	37.5 - 38.25	1435 - 1626.5	9.0 - 9.2
4.20725 - 4.20775	73 - 74.6	1645.5 - 1646.5	9.3 - 9.5
6.215 - 6.218	74.8 - 75.2	1660 - 1710	10.6 - 12.7
6.26775 - 6.26825	108 - 121.94	1718.8 - 1722.2	13.25 - 13.4
6.31175 - 6.31225	123 - 138	2200 - 2300	14.47 - 14.5
8.291 - 8.294	149.9 - 150.05	2310 - 2390	15.35 - 16.2
8.362 - 8.366	156.52475 - 156.52525	2483.5 - 2500	17.7 - 21.4
8.37625 - 8.38675	156.7 - 156.9	2655 - 2900	22.01 - 23.12
8.41425 - 8.41475	162.0125 - 167.17	3260 - 3267	23.6 - 24.0
12.29 - 12.293	167.72 - 173.2	3332 - 3339	31.2 - 31.8
12.51975 - 12.52025	240 - 285	3345.8 - 3338	36.43 - 36.5
12.57675 - 12.57725	322 - 335.4	3600 - 4400	(²)
13.36 - 13.41			

¹ Until February 1, 1999, this restricted band shall be 0.490-0.510 MHz.

² Above 38.6

§ 15.205 (b) Except as provided in paragraphs (d) and (e), the field strength of emissions appearing within these frequency bands shall not exceed the limits shown in Section 15.209. At frequencies equal to or less than 1000 MHz, compliance with the limits in Section 15.209 shall be demonstrated using measurement instrumentation employing a CISPR quasi-peak detector. Above 1000 MHz, compliance with the emission limits in Section 15.209 shall be demonstrated based on the average value of the measured emissions. The provisions in Section 15.35 apply to these measurements.



§ 15.209 (a) Except as provided elsewhere in this Subpart, the emissions from an intentional radiator shall not exceed the field strength levels specified in the following table :

Frequency (MHz)	Field Strength (microvolts/meter)	Measurement Distance (meters)
30 - 88	100 **	3
88 - 216	150 **	3
216 - 960	200 **	3
Above 960	500	3

** Except as provided in paragraph (g), fundamental emissions from intentional radiators operating under this Section shall not be located in the frequency bands 54-72 MHz, 76-88 MHz, 174-216 MHz or 470-806 MHz, However, operation within these frequency bands is permitted under other sections of this Part, e-g, Sections 15.231 and 15.241.

§ 15.209 (b) In the emission table above, the tighter limit applies at the band edges.

TEST EQUIPMENTS

The following test equipments are utilized in making the measurements contained in this report.

Open Area Test Site # 6				
Name of Equipment	Manufacturer	Model	Serial Number	Calibration Due
TYPE N COAXIAL CABLE	SUHNER	CHA9513	005	AUG. 26, 2009
EMI Receiver	R&S	ESVS10	833206/012	APR. 28, 2010
Spectrum Analyzer	R&S	FSEK 30	835253/002	OCT. 14, 2009
BI-LOG Antenna	Sunol	JB1	A070506-2	SEP. 08, 2009
Horn Antenna	Com-Power	AH-118	071032	DEC. 22, 2009
SMA RF CABLE	SUHNER	SUCOFLEX104PEA	20520/4PEA	NOV. 12, 2009
Pre-Amplifier	MITEQ	AFS44-00108650-42-10P-44	1205908	OCT. 23, 2009
Signal Generator	HP	8673C	2938A00663	JUL. 16, 2010
Pre-Amplifier	HP	8447F	2944A03817	NOV. 01, 2009
Turn Table	Yo Chen	001	-----	N.C.R.
Antenna Tower	AR	TP1000A	309874	N.C.R.
Controller	CT	SC101	-----	N.C.R.

TEST SETUP

The diagram below shows the test setup that is utilized to make the measurements for emission from 30 to 1GHz.

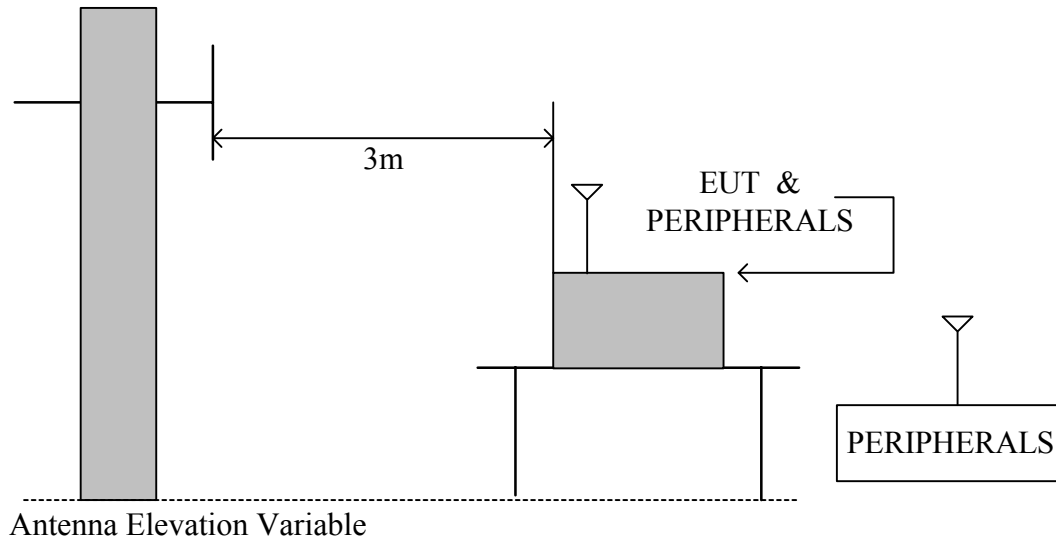

The diagram below shows the test setup that is utilized to make the measurements for emission above 1GHz.

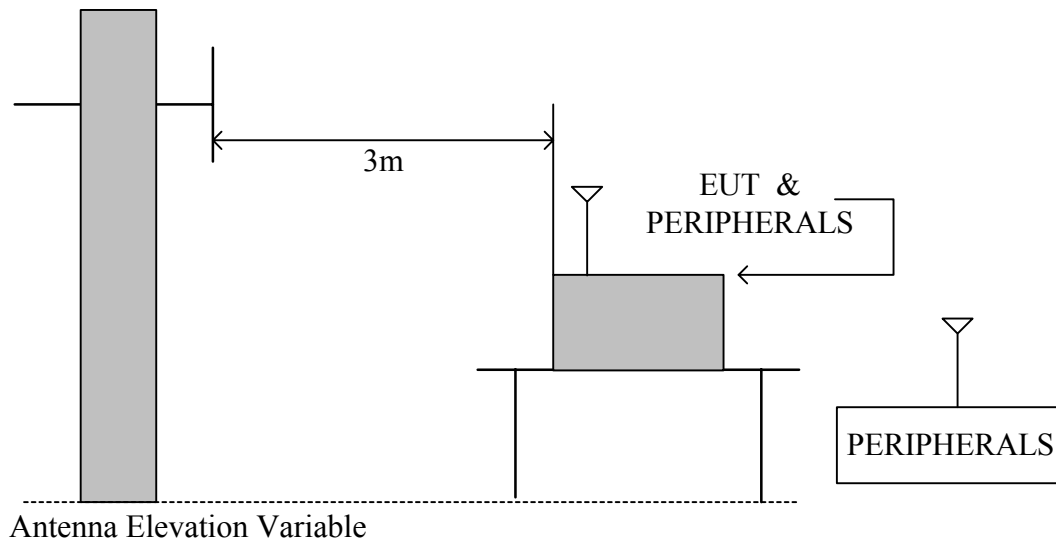



TEST PROCEDURE

- a. The EUT was placed on the top of a rotating table 0.8 meters above the ground at a 10 meter open area test site. The table was rotated 360 degrees to determine the position of the highest radiation.
- b. While measuring the radiated emission below 1GHz, the EUT was set 3 meters away from the interference-receiving antenna, which was mounted on the top of a variable-height antenna tower. While measuring the radiated emission above 1GHz, the EUT was set 3 meters away from the interference-receiving antenna
- c. The antenna is a broadband antenna, and its height is varied from one meter to four meters above the ground to determine the maximum value of the field strength. Both horizontal and vertical polarization of the antenna are set to make the measurement.
- d. For each suspected emission, the EUT was arranged to its worst case and then the antenna was tuned to heights from 1 meter to 4 meters and the table was turned from 0 degrees to 360 degrees to find the maximum reading.
- e. The test-receiver system was set to Peak Detect Function and Specified Bandwidth with Maximum Hold Mode.
- f. If the emission level of the EUT in peak mode was 10 dB lower than the limit specified, then testing could be stopped and the peak values of the EUT would be reported. Otherwise the emissions that did not have 10 dB margin would be re-tested one by one using peak, quasi-peak or average method as specified and then reported in a data sheet.

NOTE:

1. The resolution bandwidth and video bandwidth of test receiver/spectrum analyzer is 120 KHz for Peak detection (PK) and Quasi-peak detection (QP) at frequency below 1GHz.
2. The resolution bandwidth and video bandwidth of test receiver/spectrum analyzer is 1 MHz for Peak detection and frequency above 1GHz.
3. The resolution bandwidth of test receiver/spectrum analyzer is 1 MHz and the video bandwidth is 10 Hz for Average detection (AV) at frequency above 1GHz.
4. **No emission is found between lowest internal used/generated frequency to 30MHz (9kHz~30MHz)**

TEST RESULTS

No non-compliance noted.

**8.6.2 WORST-CASE RADIATED EMISSION BELOW 1 GHz**

Product Name	11n Wireless Server Router	Test Date	2009/7/22
Model	3R161N	Test By	Eric Yang
Test Mode	Normal operating / worst case	TEMP& Humidity	29.5°C, 44%

Horizontal

Frequency	Meter Reading	Antenna Factor	Cable Loss	Emission Level	Limits	Margin	Detector Mode
(MHz)	(dB μ V)	(dB/M)	(dB)	(dB μ V/M)	(dB μ V/M)	(dB)	PK/QP
50.22	15.99	8.25	1.39	25.63	40.00	-14.37	QP
140.65	13.90	13.34	2.25	29.49	43.50	-14.01	QP
250.00	15.20	12.37	3.04	30.60	46.00	-15.40	QP
320.22	15.70	14.39	3.35	33.44	46.00	-12.56	QP
400.00	24.50	16.13	3.83	44.46	46.00	-1.54	QP
479.86	18.00	17.63	4.36	39.99	46.00	-6.01	QP
499.99	13.40	18.01	4.49	35.90	46.00	-10.10	QP
800.02	7.20	21.78	5.95	34.93	46.00	-11.07	QP
N/A	-----	-----	-----	-----	-----	-----	-----

Vertical

Frequency	Meter Reading	Antenna Factor	Cable Loss	Emission Level	Limits	Margin	Detector Mode
(MHz)	(dB μ V)	(dB/M)	(dB)	(dB μ V/M)	(dB μ V/M)	(dB)	PK/QP
50.22	23.40	8.25	1.39	33.04	40.00	-6.96	QP
125.00	9.60	13.67	2.12	25.39	43.50	-18.11	QP
250.00	13.40	12.37	3.04	28.80	46.00	-17.20	QP
320.01	13.90	14.39	3.35	31.64	46.00	-14.36	QP
400.02	24.80	16.13	3.83	44.76	46.00	-1.24	QP
500.00	14.30	18.01	4.49	36.80	46.00	-9.20	QP
640.03	7.70	19.86	5.28	32.84	46.00	-13.16	QP
800.01	5.90	21.78	5.95	33.63	46.00	-12.37	QP
N/A	-----	-----	-----	-----	-----	-----	-----

REMARK: Emission level (dB μ V/m) = Antenna Factor (dB/m) + Cable loss (dB) + Meter Reading (dB μ V).

**8.6.3 TRANSMITTER RADIATED EMISSION ABOVE 1 GHz**

Product Name	1 In Wireless Server Router	Test Date	2009/7/22
Model	3R161N	Test By	Eric Yang
Test Mode	IEEE 802.11b TX (CH Low)	TEMP& Humidity	29.5°C, 44%

Horizontal

	TX / IEEE 802.11b mode / CH Low				Measurement Distance at 3m				Horizontal polarity	
	Freq.	Reading	AF	Cable Loss	Pre-amp	Filter	Level	Limit	Margin	Mark
	(MHz)	(dBμV)	(dB/m)	(dB)	(dB)	(dB)	(dBμV/m)	(dBμV/m)	(dB)	(P/Q/A)
*	4824.07	57.34	32.81	3.70	41.34	0.69	53.21	74.00	-20.79	P
*	4824.07	56.71	32.81	3.70	41.34	0.69	52.58	54.00	-1.42	A
	7236.62	47.46	38.83	4.93	41.42	1.44	51.23	74.00	-22.77	P
	7236.62	38.58	38.83	4.93	41.42	1.44	42.35	54.00	-11.65	A
	9648.13	42.50	38.75	5.74	38.43	0.61	49.18	74.00	-24.82	P
	9648.13	39.28	38.75	5.74	38.43	0.61	45.96	54.00	-8.04	A
	N/A	-----	-----	-----	-----	-----	-----	-----	-----	P
	N/A	-----	-----	-----	-----	-----	-----	-----	-----	A

REMARK:

1. AF: Antenna Factor, Cable: Cable Loss, Pre-Amp: Preamplifier gain, Filter: High Pass Filter Insertion Loss (3.5GHz)
2. Spectrum analyzer setting P(Peak): RBW=1MHz, VBW=1MHz, A(Average): RBW=1MHz, VBW=10Hz
3. The result basic equation calculation is as follow:
Level = Reading + AF + Cable – Preamp + Filter t, Margin = Level-Limit
4. The other emission levels were 20dB below the limit
5. The test limit distance is 3M limit.



Product Name	1 In Wireless Server Router	Test Date	2009/7/22
Model	3R161N	Test By	Eric Yang
Test Mode	IEEE 802.11b TX (CH Low)	TEMP& Humidity	29.5°C, 44%

Vertical

	TX / IEEE 802.11b mode / CH Low				Measurement Distance at 3m				Vertical polarity	
	Freq.	Reading	AF	Cable Loss	Pre-amp	Filter	Level	Limit	Margin	Mark
	(MHz)	(dBμV)	(dB/m)	(dB)	(dB)	(dB)	(dBμV/m)	(dBμV/m)	(dB)	(P/Q/A)
*	4824.07	53.56	32.81	3.70	41.34	0.69	49.43	74.00	-24.57	P
*	4824.07	51.64	32.81	3.70	41.34	0.69	47.51	54.00	-6.49	A
	7236.62	49.75	38.83	4.93	41.42	1.44	53.52	74.00	-20.48	P
	7236.62	42.64	38.83	4.93	41.42	1.44	46.41	54.00	-7.59	A
	9648.13	41.37	38.75	5.74	38.43	0.61	48.05	74.00	-25.95	P
	9648.13	36.42	38.75	5.74	38.43	0.61	43.10	54.00	-10.90	A
	N/A	-----	-----	-----	-----	-----	-----	-----	-----	P
	N/A	-----	-----	-----	-----	-----	-----	-----	-----	A

REMARK:

1. AF: Antenna Factor, Cable: Cable Loss, Pre-Amp: Preamplifier gain, Filter: High Pass Filter Insertion Loss (3.5GHz)
2. Spectrum analyzer setting P(Peak): RBW=1MHz, VBW=1MHz, A(Average): RBW=1MHz, VBW=10Hz
3. The result basic equation calculation is as follow:
Level = Reading + AF + Cable – Preamp + Filter, Margin = Level-Limit
4. The other emission levels were 20dB below the limit
5. The test limit distance is 3M limit.



Product Name	11n Wireless Server Router	Test Date	2009/7/22
Model	3R161N	Test By	Eric Yang
Test Mode	IEEE 802.11b TX (CH Middle)	TEMP& Humidity	29.5°C, 44%

Horizontal

	TX / IEEE 802.11b mode / CH Middle				Measurement Distance at 3m				Horizontal polarity	
	Freq. (MHz)	Reading (dBμV)	AF (dB/m)	Cable Loss (dB)	Pre-amp (dB)	Filter (dB)	Level (dBμV/m)	Limit (dBμV/m)	Margin (dB)	Mark (P/Q/A)
*	4874.07	56.34	32.92	3.73	41.41	0.71	52.30	74.00	-21.70	P
*	4874.07	55.48	32.92	3.73	41.41	0.71	51.44	54.00	-2.56	A
*	7310.61	48.63	38.93	4.96	41.32	1.59	52.80	74.00	-21.20	P
*	7310.61	39.50	38.93	4.96	41.32	1.59	43.67	54.00	-10.33	A
	9748.13	40.90	38.85	5.75	38.24	0.55	47.81	74.00	-26.19	P
	9748.13	36.08	38.85	5.75	38.24	0.55	42.99	54.00	-11.01	A
	N/A	-----	-----	-----	-----	-----	-----	-----	-----	P
	N/A	-----	-----	-----	-----	-----	-----	-----	-----	A

REMARK:

1. AF: Antenna Factor, Cable: Cable Loss, Pre-Amp: Preamplifier gain, Filter: High Pass Filter Insertion Loss (3.5GHz)
2. Spectrum analyzer setting P(Peak): RBW=1MHz, VBW=1MHz, A(Average): RBW=1MHz, VBW=10Hz
3. The result basic equation calculation is as follow:
Level = Reading + AF + Cable – Preamp + Filter, Margin = Level-Limit
4. The other emission levels were 20dB below the limit
5. The test limit distance is 3M limit.



Product Name	11n Wireless Server Router	Test Date	2009/7/22
Model	3R161N	Test By	Eric Yang
Test Mode	IEEE 802.11b TX (CH Middle)	TEMP& Humidity	29.5°C, 44%

Vertical

TX / IEEE 802.11b mode / CH Middle				Measurement Distance at 3m Vertical polarity					
Freq.	Reading	AF	Cable Loss	Pre-amp	Filter	Level	Limit	Margin	Mark
(MHz)	(dBμV)	(dB/m)	(dB)	(dB)	(dB)	(dBμV/m)	(dBμV/m)	(dB)	(P/Q/A)
* 4874.07	53.68	32.92	3.73	41.41	0.71	49.64	74.00	-24.36	P
* 4874.07	52.29	32.92	3.73	41.41	0.71	48.25	54.00	-5.75	A
* 7310.61	44.23	38.93	4.96	41.32	1.59	48.40	74.00	-25.60	P
* 7310.61	35.69	38.93	4.96	41.32	1.59	39.86	54.00	-14.14	A
9748.13	41.08	38.85	5.75	38.24	0.55	47.99	74.00	-26.01	P
9748.13	37.28	38.85	5.75	38.24	0.55	44.19	54.00	-9.81	A
N/A	-----	-----	-----	-----	-----	-----	-----	-----	P
N/A	-----	-----	-----	-----	-----	-----	-----	-----	A

REMARK:

1. AF: Antenna Factor, Cable: Cable Loss, Pre-Amp: Preamplifier gain, Filter: High Pass Filter Insertion Loss (3.5GHz)
2. Spectrum analyzer setting P(Peak): RBW=1MHz, VBW=1MHz, A(Average): RBW=1MHz, VBW=10Hz
3. The result basic equation calculation is as follow:
Level = Reading + AF + Cable – Preamp + Filter, Margin = Level-Limit
4. The other emission levels were 20dB below the limit
5. The test limit distance is 3M limit.



Product Name	11n Wireless Server Router	Test Date	2009/7/22
Model	3R161N	Test By	Eric Yang
Test Mode	IEEE 802.11b TX (CH High)	TEMP& Humidity	29.5°C, 44%

Horizontal

TX / IEEE 802.11b mode / CH High				Measurement Distance at 3m				Horizontal polarity	
Freq.	Reading	AF	Cable Loss	Pre-amp	Filter	Level	Limit	Margin	Mark
(MHz)	(dBμV)	(dB/m)	(dB)	(dB)	(dB)	(dBμV/m)	(dBμV/m)	(dB)	(P/Q/A)
* 4924.08	56.61	33.03	3.76	41.49	0.73	52.65	74.00	-21.35	P
* 4924.08	55.70	33.03	3.76	41.49	0.73	51.74	54.00	-2.26	A
* 7386.60	50.77	39.04	4.99	41.21	1.76	55.35	74.00	-18.65	P
* 7386.60	42.10	39.04	4.99	41.21	1.76	46.68	54.00	-7.32	A
9848.15	40.52	38.95	5.76	38.06	0.49	47.66	74.00	-26.34	P
9848.15	35.06	38.95	5.76	38.06	0.49	42.20	54.00	-11.80	A
N/A	-----	-----	-----	-----	-----	-----	-----	-----	P
N/A	-----	-----	-----	-----	-----	-----	-----	-----	A

REMARK:

1. AF: Antenna Factor, Cable: Cable Loss, Pre-Amp: Preamplifier gain, Filter: High Pass Filter Insertion Loss (3.5GHz)
2. Spectrum analyzer setting P(Peak): RBW=1MHz, VBW=1MHz, A(Average): RBW=1MHz, VBW=10Hz
3. The result basic equation calculation is as follow:
Level = Reading + AF + Cable – Preamp + Filter, Margin = Level-Limit
4. The other emission levels were 20dB below the limit
5. The test limit distance is 3M limit.



Product Name	11n Wireless Server Router	Test Date	2009/7/22
Model	3R161N	Test By	Eric Yang
Test Mode	IEEE 802.11b TX (CH High)	TEMP& Humidity	29.5°C, 44%

Vertical

TX / IEEE 802.11b mode / CH High				Measurement Distance at 3m Vertical polarity					
Freq.	Reading	AF	Cable Loss	Pre-amp	Filter	Level	Limit	Margin	Mark
(MHz)	(dBμV)	(dB/m)	(dB)	(dB)	(dB)	(dBμV/m)	(dBμV/m)	(dB)	(P/Q/A)
* 4924.08	56.10	33.03	3.76	41.49	0.73	52.14	74.00	-21.86	P
* 4924.08	55.10	33.03	3.76	41.49	0.73	51.14	54.00	-2.86	A
* 7386.60	44.72	39.04	4.99	41.21	1.76	49.30	74.00	-24.70	P
* 7386.60	35.41	39.04	4.99	41.21	1.76	39.99	54.00	-14.01	A
9848.15	41.26	38.95	5.76	38.06	0.49	48.40	74.00	-25.60	P
9848.15	35.24	38.95	5.76	38.06	0.49	42.38	54.00	-11.62	A
N/A	-----	-----	-----	-----	-----	-----	-----	-----	P
N/A	-----	-----	-----	-----	-----	-----	-----	-----	A

REMARK:

1. AF: Antenna Factor, Cable: Cable Loss, Pre-Amp: Preamplifier gain, Filter: High Pass Filter Insertion Loss (3.5GHz)
2. Spectrum analyzer setting P(Peak): RBW=1MHz, VBW=1MHz, A(Average): RBW=1MHz, VBW=10Hz
3. The result basic equation calculation is as follow:
Level = Reading + AF + Cable – Preamp + Filter, Margin = Level-Limit
4. The other emission levels were 20dB below the limit
5. The test limit distance is 3M limit.



Product Name	1 In Wireless Server Router	Test Date	2009/7/22
Model	3R161N	Test By	Eric Yang
Test Mode	IEEE 802.11g TX (CH Low)	TEMP& Humidity	29.5°C, 44%

Horizontal

TX / IEEE 802.11g mode / CH Low				Measurement Distance at 3m				Horizontal polarity		
Freq.	Reading	AF	Cable Loss	Pre-amp	Filter	Level	Limit	Margin	Mark	
(MHz)	(dBμV)	(dB/m)	(dB)	(dB)	(dB)	(dBμV/m)	(dBμV/m)	(dB)	(P/Q/A)	
* 4824.65	53.62	32.81	3.71	41.34	0.69	49.50	74.00	-24.50	P	
* 4824.65	45.71	32.81	3.71	41.34	0.69	41.59	54.00	-12.41	A	
7237.53	51.42	38.83	4.93	41.42	1.44	55.20	74.00	-18.80	P	
7237.53	44.68	38.83	4.93	41.42	1.44	48.46	54.00	-5.54	A	
9648.12	51.24	38.75	5.74	38.43	0.61	57.92	74.00	-16.08	P	
9648.12	41.55	38.75	5.74	38.43	0.61	48.23	54.00	-5.77	A	
N/A	-----	-----	-----	-----	-----	-----	-----	-----	P	
N/A	-----	-----	-----	-----	-----	-----	-----	-----	A	

REMARK:

1. AF: Antenna Factor, Cable: Cable Loss, Pre-Amp: Preamplifier gain, Filter: High Pass Filter Insertion Loss (3.5GHz)
2. Spectrum analyzer setting P(Peak): RBW=1MHz, VBW=1MHz, A(Average): RBW=1MHz, VBW=10Hz
3. The result basic equation calculation is as follow:
Level = Reading + AF + Cable – Preamp + Filter, Margin = Level-Limit
4. The other emission levels were 20dB below the limit
5. The test limit distance is 3M limit.



Product Name	1 In Wireless Server Router	Test Date	2009/7/22
Model	3R161N	Test By	Eric Yang
Test Mode	IEEE 802.11g TX (CH Low)	TEMP& Humidity	29.5°C, 44%

Vertical

TX / IEEE 802.11g mode / CH Low				Measurement Distance at 3m				Vertical polarity	
Freq.	Reading	AF	Cable Loss	Pre-amp	Filter	Level	Limit	Margin	Mark
(MHz)	(dBμV)	(dB/m)	(dB)	(dB)	(dB)	(dBμV/m)	(dBμV/m)	(dB)	(P/Q/A)
* 4823.55	50.62	32.81	3.70	41.34	0.69	46.49	74.00	-27.51	P
* 4823.55	42.33	32.81	3.70	41.34	0.69	38.20	54.00	-15.80	A
7235.89	50.24	38.83	4.93	41.43	1.43	54.01	74.00	-19.99	P
7235.89	42.58	38.83	4.93	41.43	1.43	46.35	54.00	-7.65	A
9647.58	51.68	38.75	5.74	38.43	0.61	58.36	74.00	-15.64	P
9647.58	41.17	38.75	5.74	38.43	0.61	47.85	54.00	-6.15	A
N/A	-----	-----	-----	-----	-----	-----	-----	-----	P
N/A	-----	-----	-----	-----	-----	-----	-----	-----	A

REMARK:

1. AF: Antenna Factor, Cable: Cable Loss, Pre-Amp: Preamplifier gain, Filter: High Pass Filter Insertion Loss (3.5GHz)
2. Spectrum analyzer setting P(Peak): RBW=1MHz, VBW=1MHz, A(Average): RBW=1MHz, VBW=10Hz
3. The result basic equation calculation is as follow:
Level = Reading + AF + Cable – Preamp + Filter, Margin = Level-Limit
4. The other emission levels were 20dB below the limit
5. The test limit distance is 3M limit.



Product Name	11n Wireless Server Router	Test Date	2009/7/22
Model	3R161N	Test By	Eric Yang
Test Mode	IEEE 802.11g TX (CH Middle)	TEMP& Humidity	29.5°C, 44%

Horizontal

	TX / IEEE 802.11g mode / CH Middle				Measurement Distance at 3m				Horizontal polarity	
	Freq.	Reading	AF	Cable Loss	Pre-amp	Filter	Level	Limit	Margin	Mark
	(MHz)	(dBμV)	(dB/m)	(dB)	(dB)	(dB)	(dBμV/m)	(dBμV/m)	(dB)	(P/Q/A)
*	4872.69	53.65	32.92	3.73	41.41	0.71	49.60	74.00	-24.40	P
*	4872.69	44.71	32.92	3.73	41.41	0.71	40.66	54.00	-13.34	A
*	7315.82	52.26	38.94	4.96	41.31	1.61	56.46	74.00	-17.54	P
*	7315.82	43.61	38.94	4.96	41.31	1.61	47.81	54.00	-6.19	A
	9749.52	52.64	38.85	5.75	38.24	0.55	59.55	74.00	-14.45	P
	9749.52	42.81	38.85	5.75	38.24	0.55	49.72	54.00	-4.28	A
	N/A	-----	-----	-----	-----	-----	-----	-----	-----	P
	N/A	-----	-----	-----	-----	-----	-----	-----	-----	A

REMARK:

1. AF: Antenna Factor, Cable: Cable Loss, Pre-Amp: Preamplifier gain, Filter: High Pass Filter Insertion Loss (3.5GHz)
2. Spectrum analyzer setting P(Peak): RBW=1MHz, VBW=1MHz, A(Average): RBW=1MHz, VBW=10Hz
3. The result basic equation calculation is as follow:

$$\text{Level} = \text{Reading} + \text{AF} + \text{Cable} - \text{Preamp} + \text{Filter}, \text{Margin} = \text{Level} - \text{Limit}$$
4. The other emission levels were 20dB below the limit
5. The test limit distance is 3M limit.



Product Name	11n Wireless Server Router	Test Date	2009/7/22
Model	3R161N	Test By	Eric Yang
Test Mode	IEEE 802.11g TX (CH Middle)	TEMP& Humidity	29.5°C, 44%

Vertical

TX / IEEE 802.11g mode / CH Middle				Measurement Distance at 3m Vertical polarity					
Freq.	Reading	AF	Cable Loss	Pre-amp	Filter	Level	Limit	Margin	Mark
(MHz)	(dBμV)	(dB/m)	(dB)	(dB)	(dB)	(dBμV/m)	(dBμV/m)	(dB)	(P/Q/A)
* 4873.25	51.62	32.92	3.73	41.41	0.71	47.57	74.00	-26.43	P
* 4873.25	41.75	32.92	3.73	41.41	0.71	37.70	54.00	-16.30	A
* 7315.46	50.22	38.94	4.96	41.31	1.61	54.42	74.00	-19.58	P
* 7315.46	41.36	38.94	4.96	41.31	1.61	45.56	54.00	-8.44	A
9747.33	51.14	38.85	5.75	38.24	0.55	58.05	74.00	-15.95	P
9747.33	41.75	38.85	5.75	38.24	0.55	48.66	54.00	-5.34	A
N/A	-----	-----	-----	-----	-----	-----	-----	-----	P
N/A	-----	-----	-----	-----	-----	-----	-----	-----	A

REMARK:

1. AF: Antenna Factor, Cable: Cable Loss, Pre-Amp: Preamplifier gain, Filter: High Pass Filter Insertion Loss (3.5GHz)
2. Spectrum analyzer setting P(Peak): RBW=1MHz, VBW=1MHz, A(Average): RBW=1MHz, VBW=10Hz
3. The result basic equation calculation is as follow:
Level = Reading + AF + Cable – Preamp + Filter, Margin = Level-Limit
4. The other emission levels were 20dB below the limit
5. The test limit distance is 3M limit.



Product Name	11n Wireless Server Router	Test Date	2009/7/22
Model	3R161N	Test By	Eric Yang
Test Mode	IEEE 802.11g TX (CH High)	TEMP& Humidity	29.5°C, 44%

Horizontal

TX / IEEE 802.11g mode / CH High				Measurement Distance at 3m				Horizontal polarity	
Freq.	Reading	AF	Cable Loss	Pre-amp	Filter	Level	Limit	Margin	Mark
(MHz)	(dBμV)	(dB/m)	(dB)	(dB)	(dB)	(dBμV/m)	(dBμV/m)	(dB)	(P/Q/A)
* 4925.83	53.62	33.04	3.76	41.49	0.73	49.66	74.00	-24.34	P
* 4925.83	44.75	33.04	3.76	41.49	0.73	40.79	54.00	-13.21	A
* 7387.29	51.89	39.04	4.99	41.21	1.76	56.47	74.00	-17.53	P
* 7387.29	42.67	39.04	4.99	41.21	1.76	47.25	54.00	-6.75	A
9849.75	52.64	38.95	5.76	38.06	0.49	59.79	74.00	-14.21	P
9849.75	42.75	38.95	5.76	38.06	0.49	49.90	54.00	-4.10	A
N/A	-----	-----	-----	-----	-----	-----	-----	-----	P
N/A	-----	-----	-----	-----	-----	-----	-----	-----	A

REMARK:

1. AF: Antenna Factor, Cable: Cable Loss, Pre-Amp: Preamplifier gain, Filter: High Pass Filter Insertion Loss (3.5GHz)
2. Spectrum analyzer setting P(Peak): RBW=1MHz, VBW=1MHz, A(Average): RBW=1MHz, VBW=10Hz
3. The result basic equation calculation is as follow:
Level = Reading + AF + Cable – Preamp + Filter, Margin = Level-Limit
4. The other emission levels were 20dB below the limit
5. The test limit distance is 3M limit.



Product Name	11n Wireless Server Router	Test Date	2009/7/22
Model	3R161N	Test By	Eric Yang
Test Mode	IEEE 802.11g TX (CH High)	TEMP& Humidity	29.5°C, 44%

Vertical

TX / IEEE 802.11g mode / CH High				Measurement Distance at 3m				Vertical polarity	
Freq.	Reading	AF	Cable Loss	Pre-amp	Filter	Level	Limit	Margin	Mark
(MHz)	(dBμV)	(dB/m)	(dB)	(dB)	(dB)	(dBμV/m)	(dBμV/m)	(dB)	(P/Q/A)
* 4923.55	51.42	33.03	3.76	41.49	0.73	47.46	74.00	-26.54	P
* 4923.55	42.36	33.03	3.76	41.49	0.73	38.40	54.00	-15.60	A
* 7386.42	51.14	39.04	4.99	41.21	1.76	55.72	74.00	-18.28	P
* 7386.42	41.85	39.04	4.99	41.21	1.76	46.43	54.00	-7.57	A
9846.53	51.22	38.95	5.76	38.06	0.49	58.36	74.00	-15.64	P
9846.53	41.36	38.95	5.76	38.06	0.49	48.50	54.00	-5.50	A
N/A	-----	-----	-----	-----	-----	-----	-----	-----	P
N/A	-----	-----	-----	-----	-----	-----	-----	-----	A

REMARK:

1. AF: Antenna Factor, Cable: Cable Loss, Pre-Amp: Preamplifier gain, Filter: High Pass Filter Insertion Loss (3.5GHz)
2. Spectrum analyzer setting P(Peak): RBW=1MHz, VBW=1MHz, A(Average): RBW=1MHz, VBW=10Hz
3. The result basic equation calculation is as follow:
Level = Reading + AF + Cable – Preamp + Filter, Margin = Level-Limit
4. The other emission levels were 20dB below the limit
5. The test limit distance is 3M limit.



Product Name	11n Wireless Server Router	Test Date	2009/7/22
Model	3R161N	Test By	Eric Yang
Test Mode	IEEE 802.11n HT20 TX (CH Low)	TEMP& Humidity	29.5°C, 44%

Horizontal

	TX / IEEE 802.11n HT20 mode / CH Low				Measurement Distance at 3m				Horizontal polarity	
	Freq. (MHz)	Reading (dBμV)	AF (dB/m)	Cable Loss (dB)	Pre-amp (dB)	Filter (dB)	Level (dBμV/m)	Limit (dBμV/m)	Margin (dB)	Mark (P/Q/A)
*	4823.59	53.62	32.81	3.70	41.34	0.69	49.49	74.00	-24.51	P
*	4823.59	43.22	32.81	3.70	41.34	0.69	39.09	54.00	-14.91	A
	7235.46	52.57	38.83	4.93	41.43	1.43	56.34	74.00	-17.66	P
	7235.46	42.68	38.83	4.93	41.43	1.43	46.45	54.00	-7.55	A
	9646.95	53.62	38.75	5.74	38.43	0.61	60.29	74.00	-13.71	P
	9646.95	43.25	38.75	5.74	38.43	0.61	49.92	54.00	-4.08	A
	N/A	-----	-----	-----	-----	-----	-----	-----	-----	P
	N/A	-----	-----	-----	-----	-----	-----	-----	-----	A

REMARK:

1. AF: Antenna Factor, Cable: Cable Loss, Pre-Amp: Preamplifier gain, Filter: High Pass Filter Insertion Loss (3.5GHz)
2. Spectrum analyzer setting P(Peak): RBW=1MHz, VBW=1MHz, A(Average): RBW=1MHz, VBW=10Hz
3. The result basic equation calculation is as follow:
Level = Reading + AF + Cable – Preamp + Filter, Margin = Level-Limit
4. The other emission levels were 20dB below the limit
5. The test limit distance is 3M limit.



Product Name	11n Wireless Server Router	Test Date	2009/7/22
Model	3R161N	Test By	Eric Yang
Test Mode	IEEE 802.11n HT20 TX (CH Low)	TEMP& Humidity	29.5°C, 44%

Vertical

	TX / IEEE 802.11n HT20 mode / CH Low				Measurement Distance at 3m				Vertical polarity	
	Freq.	Reading	AF	Cable Loss	Pre-amp	Filter	Level	Limit	Margin	Mark
	(MHz)	(dBμV)	(dB/m)	(dB)	(dB)	(dB)	(dBμV/m)	(dBμV/m)	(dB)	(P/Q/A)
*	4825.61	51.22	32.82	3.71	41.34	0.69	47.10	74.00	-26.90	P
*	4825.61	41.68	32.82	3.71	41.34	0.69	37.56	54.00	-16.44	A
	7234.65	52.16	38.83	4.93	41.43	1.43	55.92	74.00	-18.08	P
	7234.65	42.35	38.83	4.93	41.43	1.43	46.11	54.00	-7.89	A
	9647.85	51.62	38.75	5.74	38.43	0.61	58.30	74.00	-15.70	P
	9647.85	41.33	38.75	5.74	38.43	0.61	48.01	54.00	-5.99	A
	N/A	-----	-----	-----	-----	-----	-----	-----	-----	P
	N/A	-----	-----	-----	-----	-----	-----	-----	-----	A

REMARK:

1. AF: Antenna Factor, Cable: Cable Loss, Pre-Amp: Preamplifier gain, Filter: High Pass Filter Insertion Loss (3.5GHz)
2. Spectrum analyzer setting P(Peak): RBW=1MHz, VBW=1MHz, A(Average): RBW=1MHz, VBW=10Hz
3. The result basic equation calculation is as follow:
Level = Reading + AF + Cable – Preamp + Filter, Margin = Level-Limit
4. The other emission levels were 20dB below the limit
5. The test limit distance is 3M limit.



Product Name	11n Wireless Server Router	Test Date	2009/7/22
Model	3R161N	Test By	Eric Yang
Test Mode	IEEE 802.11n HT20 TX (CH Middle)	TEMP& Humidity	29.5°C, 44%

Horizontal

	TX / IEEE 802.11n HT20 mode / CH Middle				Measurement Distance at 3m				Horizontal polarity	
	Freq. (MHz)	Reading (dBμV)	AF (dB/m)	Cable Loss (dB)	Pre-amp (dB)	Filter (dB)	Level (dBμV/m)	Limit (dBμV/m)	Margin (dB)	Mark (P/Q/A)
*	4871.53	53.62	32.92	3.73	41.41	0.71	49.57	74.00	-24.43	P
*	4871.53	42.18	32.92	3.73	41.41	0.71	38.13	54.00	-15.87	A
*	7316.24	52.84	38.94	4.96	41.31	1.61	57.04	74.00	-16.96	P
*	7316.24	42.67	38.94	4.96	41.31	1.61	46.87	54.00	-7.13	A
	9749.51	53.26	38.85	5.75	38.24	0.55	60.17	74.00	-13.83	P
	9749.51	42.51	38.85	5.75	38.24	0.55	49.42	54.00	-4.58	A
	N/A	-----	-----	-----	-----	-----	-----	-----	-----	P
	N/A	-----	-----	-----	-----	-----	-----	-----	-----	A

REMARK:

1. AF: Antenna Factor, Cable: Cable Loss, Pre-Amp: Preamplifier gain, Filter: High Pass Filter Insertion Loss (3.5GHz)
2. Spectrum analyzer setting P(Peak): RBW=1MHz, VBW=1MHz, A(Average): RBW=1MHz, VBW=10Hz
3. The result basic equation calculation is as follow:
Level = Reading + AF + Cable – Preamp + Filter, Margin = Level-Limit
4. The other emission levels were 20dB below the limit
5. The test limit distance is 3M limit.



Product Name	11n Wireless Server Router	Test Date	2009/7/22
Model	3R161N	Test By	Eric Yang
Test Mode	IEEE 802.11n HT20 TX (CH Middle)	TEMP& Humidity	29.5°C, 44%

Vertical

	TX / IEEE 802.11n HT20 mode / CH Middle				Measurement Distance at 3m				Vertical polarity	
	Freq. (MHz)	Reading (dBμV)	AF (dB/m)	Cable Loss (dB)	Pre-amp (dB)	Filter (dB)	Level (dBμV/m)	Limit (dBμV/m)	Margin (dB)	Mark (P/Q/A)
*	4872.16	50.62	32.92	3.73	41.41	0.71	46.57	74.00	-27.43	P
*	4872.16	41.85	32.92	3.73	41.41	0.71	37.80	54.00	-16.20	A
*	7316.24	51.68	38.94	4.96	41.31	1.61	55.88	74.00	-18.12	P
*	7316.24	41.75	38.94	4.96	41.31	1.61	45.95	54.00	-8.05	A
	9748.62	51.22	38.85	5.75	38.24	0.55	58.13	74.00	-15.87	P
	9748.62	41.26	38.85	5.75	38.24	0.55	48.17	54.00	-5.83	A
	N/A	-----	-----	-----	-----	-----	-----	-----	-----	P
	N/A	-----	-----	-----	-----	-----	-----	-----	-----	A

REMARK:

1. AF: Antenna Factor, Cable: Cable Loss, Pre-Amp: Preamplifier gain, Filter: High Pass Filter Insertion Loss (3.5GHz)
2. Spectrum analyzer setting P(Peak): RBW=1MHz, VBW=1MHz, A(Average): RBW=1MHz, VBW=10Hz
3. The result basic equation calculation is as follow:
Level = Reading + AF + Cable – Preamp + Filter, Margin = Level-Limit
4. The other emission levels were 20dB below the limit
5. The test limit distance is 3M limit.



Product Name	11n Wireless Server Router	Test Date	2009/7/22
Model	3R161N	Test By	Eric Yang
Test Mode	IEEE 802.11n HT20 TX (CH High)	TEMP& Humidity	29.5°C, 44%

Horizontal

	TX / IEEE 802.11n HT20 mode / CH High				Measurement Distance at 3m				Horizontal polarity	
	Freq. (MHz)	Reading (dBμV)	AF (dB/m)	Cable Loss (dB)	Pre-amp (dB)	Filter (dB)	Level (dBμV/m)	Limit (dBμV/m)	Margin (dB)	Mark (P/Q/A)
*	4926.85	52.64	33.04	3.76	41.49	0.73	48.68	74.00	-25.32	P
*	4926.85	42.55	33.04	3.76	41.49	0.73	38.59	54.00	-15.41	A
*	7383.42	53.62	39.04	4.99	41.22	1.75	58.18	74.00	-15.82	P
*	7383.42	42.81	39.04	4.99	41.22	1.75	47.37	54.00	-6.63	A
	9849.65	52.64	38.95	5.76	38.06	0.49	59.79	74.00	-14.21	P
	9849.65	42.17	38.95	5.76	38.06	0.49	49.32	54.00	-4.68	A
	N/A	-----	-----	-----	-----	-----	-----	-----	-----	P
	N/A	-----	-----	-----	-----	-----	-----	-----	-----	A

REMARK:

1. AF: Antenna Factor, Cable: Cable Loss, Pre-Amp: Preamplifier gain, Filter: High Pass Filter Insertion Loss (3.5GHz)
2. Spectrum analyzer setting P(Peak): RBW=1MHz, VBW=1MHz, A(Average): RBW=1MHz, VBW=10Hz
3. The result basic equation calculation is as follow:
Level = Reading + AF + Cable – Preamp + Filter, Margin = Level-Limit
4. The other emission levels were 20dB below the limit
5. The test limit distance is 3M limit.



Product Name	11n Wireless Server Router	Test Date	2009/7/22
Model	3R161N	Test By	Eric Yang
Test Mode	IEEE 802.11n HT20 TX (CH High)	TEMP& Humidity	29.5°C, 44%

Vertical

TX / IEEE 802.11n HT20 mode / CH High				Measurement Distance at 3m				Vertical polarity	
Freq.	Reading	AF	Cable Loss	Pre-amp	Filter	Level	Limit	Margin	Mark
(MHz)	(dBμV)	(dB/m)	(dB)	(dB)	(dB)	(dBμV/m)	(dBμV/m)	(dB)	(P/Q/A)
* 4925.86	51.22	33.04	3.76	41.49	0.73	47.26	74.00	-26.74	P
* 4925.86	42.35	33.04	3.76	41.49	0.73	38.39	54.00	-15.61	A
* 7382.56	50.65	39.04	4.99	41.22	1.75	55.21	74.00	-18.79	P
* 7382.56	40.85	39.04	4.99	41.22	1.75	45.41	54.00	-8.59	A
9848.65	51.11	38.95	5.76	38.06	0.49	58.26	74.00	-15.74	P
9848.65	41.36	38.95	5.76	38.06	0.49	48.51	54.00	-5.49	A
N/A	-----	-----	-----	-----	-----	-----	-----	-----	A

REMARK:

1. AF: Antenna Factor, Cable: Cable Loss, Pre-Amp: Preamplifier gain, Filter: High Pass Filter Insertion Loss (3.5GHz)
2. Spectrum analyzer setting P(Peak): RBW=1MHz, VBW=1MHz, A(Average): RBW=1MHz, VBW=10Hz
3. The result basic equation calculation is as follow:
Level = Reading + AF + Cable – Preamp + Filter, Margin = Level-Limit
4. The other emission levels were 20dB below the limit
5. The test limit distance is 3M limit.



Product Name	11n Wireless Server Router	Test Date	2009/7/22
Model	3R161N	Test By	Eric Yang
Test Mode	IEEE 802.11n HT40 TX (CH Low)	TEMP& Humidity	29.5°C, 44%

Horizontal

	TX / IEEE 802.11n HT40 mode / CH Low				Measurement Distance at 3m				Horizontal polarity	
	Freq.	Reading	AF	Cable Loss	Pre-amp	Filter	Level	Limit	Margin	Mark
	(MHz)	(dBμV)	(dB/m)	(dB)	(dB)	(dB)	(dBμV/m)	(dBμV/m)	(dB)	(P/Q/A)
*	4843.65	52.44	32.86	3.72	41.37	0.70	48.35	74.00	-25.65	P
*	4843.65	42.15	32.86	3.72	41.37	0.70	38.06	54.00	-15.94	A
*	7263.85	51.68	38.87	4.94	41.39	1.49	55.60	74.00	-18.40	P
*	7263.85	41.75	38.87	4.94	41.39	1.49	45.67	54.00	-8.33	A
	9686.72	52.25	38.79	5.75	38.36	0.59	59.02	74.00	-14.98	P
	9686.72	42.35	38.79	5.75	38.36	0.59	49.12	54.00	-4.88	A
	N/A	-----	-----	-----	-----	-----	-----	-----	-----	P
	N/A	-----	-----	-----	-----	-----	-----	-----	-----	A

REMARK:

1. AF: Antenna Factor, Cable: Cable Loss, Pre-Amp: Preamplifier gain, Filter: High Pass Filter Insertion Loss (3.5GHz)
2. Spectrum analyzer setting P(Peak): RBW=1MHz, VBW=1MHz, A(Average): RBW=1MHz, VBW=10Hz
3. The result basic equation calculation is as follow:
Level = Reading + AF + Cable – Preamp + Filter, Margin = Level-Limit
4. The other emission levels were 20dB below the limit
5. The test limit distance is 3M limit.



Product Name	11n Wireless Server Router	Test Date	2009/7/22
Model	3R161N	Test By	Eric Yang
Test Mode	IEEE 802.11n HT40 TX (CH Low)	TEMP& Humidity	29.5°C, 44%

Vertical

	TX / IEEE 802.11n HT40 mode / CH Low				Measurement Distance at 3m				Vertical polarity	
	Freq.	Reading	AF	Cable Loss	Pre-amp	Filter	Level	Limit	Margin	Mark
	(MHz)	(dBμV)	(dB/m)	(dB)	(dB)	(dB)	(dBμV/m)	(dBμV/m)	(dB)	(P/Q/A)
*	4842.65	51.24	32.85	3.72	41.36	0.70	47.15	74.00	-26.85	P
*	4842.65	41.22	32.85	3.72	41.36	0.70	37.13	54.00	-16.87	A
*	7263.45	50.62	38.87	4.94	41.39	1.49	54.54	74.00	-19.46	P
*	7263.45	40.38	38.87	4.94	41.39	1.49	44.30	54.00	-9.70	A
	9686.33	50.22	38.79	5.75	38.36	0.59	56.99	74.00	-17.01	P
	9686.33	39.58	38.79	5.75	38.36	0.59	46.35	54.00	-7.65	A
	N/A	-----	-----	-----	-----	-----	-----	-----	-----	P
	N/A	-----	-----	-----	-----	-----	-----	-----	-----	A

REMARK:

1. AF: Antenna Factor, Cable: Cable Loss, Pre-Amp: Preamplifier gain, Filter: High Pass Filter Insertion Loss (3.5GHz)
2. Spectrum analyzer setting P(Peak): RBW=1MHz, VBW=1MHz, A(Average): RBW=1MHz, VBW=10Hz
3. The result basic equation calculation is as follow:
Level = Reading + AF + Cable – Preamp + Filter, Margin = Level-Limit
4. The other emission levels were 20dB below the limit
5. The test limit distance is 3M limit.



Product Name	11n Wireless Server Router	Test Date	2009/7/22
Model	3R161N	Test By	Eric Yang
Test Mode	IEEE 802.11n HT40 TX (CH Middle)	TEMP& Humidity	29.5°C, 44%

Horizontal

	TX / IEEE 802.11n HT40 mode / CH Middle				Measurement Distance at 3m				Horizontal polarity	
	Freq. (MHz)	Reading (dBμV)	AF (dB/m)	Cable Loss (dB)	Pre-amp (dB)	Filter (dB)	Level (dBμV/m)	Limit (dBμV/m)	Margin (dB)	Mark (P/Q/A)
*	4873.26	52.34	32.92	3.73	41.41	0.71	48.29	74.00	-25.71	P
*	4873.26	42.15	32.92	3.73	41.41	0.71	38.10	54.00	-15.90	A
*	7292.24	51.86	38.91	4.95	41.35	1.56	55.93	74.00	-18.07	P
*	7292.24	41.35	38.91	4.95	41.35	1.56	45.42	54.00	-8.58	A
	9746.85	52.22	38.85	5.75	38.25	0.55	59.13	74.00	-14.87	P
	9746.85	42.75	38.85	5.75	38.25	0.55	49.66	54.00	-4.34	A
	N/A	-----	-----	-----	-----	-----	-----	-----	-----	P
	N/A	-----	-----	-----	-----	-----	-----	-----	-----	A

REMARK:

1. AF: Antenna Factor, Cable: Cable Loss, Pre-Amp: Preamplifier gain, Filter: High Pass Filter Insertion Loss (3.5GHz)
2. Spectrum analyzer setting P(Peak): RBW=1MHz, VBW=1MHz, A(Average): RBW=1MHz, VBW=10Hz
3. The result basic equation calculation is as follow:
Level = Reading + AF + Cable – Preamp + Filter, Margin = Level-Limit
4. The other emission levels were 20dB below the limit
5. The test limit distance is 3M limit.



Product Name	11n Wireless Server Router	Test Date	2009/7/22
Model	3R161N	Test By	Eric Yang
Test Mode	IEEE 802.11n HT40 TX (CH Middle)	TEMP& Humidity	29.5°C, 44%

Vertical

	TX / IEEE 802.11n HT40 mode / CH Middle				Measurement Distance at 3m				Vertical polarity	
	Freq. (MHz)	Reading (dBμV)	AF (dB/m)	Cable Loss (dB)	Pre-amp (dB)	Filter (dB)	Level (dBμV/m)	Limit (dBμV/m)	Margin (dB)	Mark (P/Q/A)
*	4874.26	51.24	32.92	3.73	41.41	0.71	47.20	74.00	-26.80	P
*	4874.26	41.22	32.92	3.73	41.41	0.71	37.18	54.00	-16.82	A
*	7293.15	50.26	38.91	4.95	41.34	1.56	54.34	74.00	-19.66	P
*	7293.15	40.33	38.91	4.95	41.34	1.56	44.41	54.00	-9.59	A
	9747.51	51.24	38.85	5.75	38.24	0.55	58.15	74.00	-15.85	P
	9747.51	41.38	38.85	5.75	38.24	0.55	48.29	54.00	-5.71	A
	N/A	-----	-----	-----	-----	-----	-----	-----	-----	P
	N/A	-----	-----	-----	-----	-----	-----	-----	-----	A

REMARK:

1. AF: Antenna Factor, Cable: Cable Loss, Pre-Amp: Preamplifier gain, Filter: High Pass Filter Insertion Loss (3.5GHz)
2. Spectrum analyzer setting P(Peak): RBW=1MHz, VBW=1MHz, A(Average): RBW=1MHz, VBW=10Hz
3. The result basic equation calculation is as follow:
Level = Reading + AF + Cable – Preamp + Filter, Margin = Level-Limit
4. The other emission levels were 20dB below the limit
5. The test limit distance is 3M limit.



Product Name	11n Wireless Server Router	Test Date	2009/7/22
Model	3R161N	Test By	Eric Yang
Test Mode	IEEE 802.11n HT40 TX (CH High)	TEMP& Humidity	29.5°C, 44%

Horizontal

	TX / IEEE 802.11n HT40 mode / CH High				Measurement Distance at 3m				Horizontal polarity	
	Freq. (MHz)	Reading (dBμV)	AF (dB/m)	Cable Loss (dB)	Pre-amp (dB)	Filter (dB)	Level (dBμV/m)	Limit (dBμV/m)	Margin (dB)	Mark (P/Q/A)
*	4904.52	53.20	32.99	3.75	41.46	0.72	49.21	74.00	-24.79	P
*	4904.52	43.26	32.99	3.75	41.46	0.72	39.27	54.00	-14.73	A
*	7354.68	52.41	39.00	4.98	41.26	1.69	56.82	74.00	-17.18	P
*	7354.68	41.22	39.00	4.98	41.26	1.69	45.63	54.00	-8.37	A
	9807.56	52.14	38.91	5.76	38.13	0.52	59.19	74.00	-14.81	P
	9807.56	42.36	38.91	5.76	38.13	0.52	49.41	54.00	-4.59	A
	N/A	-----	-----	-----	-----	-----	-----	-----	-----	P
	N/A	-----	-----	-----	-----	-----	-----	-----	-----	A

REMARK:

1. AF: Antenna Factor, Cable: Cable Loss, Pre-Amp: Preamplifier gain, Filter: High Pass Filter Insertion Loss (3.5GHz)
2. Spectrum analyzer setting P(Peak): RBW=1MHz, VBW=1MHz, A(Average): RBW=1MHz, VBW=10Hz
3. The result basic equation calculation is as follow:
Level = Reading + AF + Cable – Preamp + Filter, Margin = Level-Limit
4. The other emission levels were 20dB below the limit
5. The test limit distance is 3M limit.



Product Name	11n Wireless Server Router	Test Date	2009/7/22
Model	3R161N	Test By	Eric Yang
Test Mode	IEEE 802.11n HT40 TX (CH High)	TEMP& Humidity	29.5°C, 44%

Vertical

TX / IEEE 802.11n HT40 mode / CH High				Measurement Distance at 3m				Vertical polarity	
Freq.	Reading	AF	Cable Loss	Pre-amp	Filter	Level	Limit	Margin	Mark
(MHz)	(dBμV)	(dB/m)	(dB)	(dB)	(dB)	(dBμV/m)	(dBμV/m)	(dB)	(P/Q/A)
* 4903.52	51.24	32.99	3.75	41.46	0.72	47.24	74.00	-26.76	P
* 4903.52	41.25	32.99	3.75	41.46	0.72	37.25	54.00	-16.75	A
* 7353.64	50.26	39.00	4.98	41.26	1.69	54.66	74.00	-19.34	P
* 7353.64	40.75	39.00	4.98	41.26	1.69	45.15	54.00	-8.85	A
9807.42	51.22	38.91	5.76	38.13	0.52	58.27	74.00	-15.73	P
9807.42	41.36	38.91	5.76	38.13	0.52	48.41	54.00	-5.59	A
N/A	-----	-----	-----	-----	-----	-----	-----	-----	P
N/A	-----	-----	-----	-----	-----	-----	-----	-----	A

REMARK:

1. AF: Antenna Factor, Cable: Cable Loss, Pre-Amp: Preamplifier gain, Filter: High Pass Filter Insertion Loss (3.5GHz)
2. Spectrum analyzer setting P(Peak): RBW=1MHz, VBW=1MHz, A(Average): RBW=1MHz, VBW=10Hz
3. The result basic equation calculation is as follow:
Level = Reading + AF + Cable – Preamp + Filter, Margin = Level-Limit
4. The other emission levels were 20dB below the limit
5. The test limit distance is 3M limit.



8.6.4 RESTRICTED BAND EDGES

IEEE 802.11b mode

Channel	Polarity	Freq.(MHz)	Level(dBuV)	Limit(dBuV)	Margin(dB)	Detector
LOW	H	2390.00	58.05	74	-15.95	Peak
	H	2390.00	45.92	54	-8.08	Average
	V	2390.00	58.02	74	-15.98	Peak
	V	2390.00	45.8	54	-8.20	Average
HIGH	H	2483.50	58.38	74	-15.62	Peak
	H	2483.50	45.76	54	-8.24	Average
	V	2483.50	59.13	74	-14.87	Peak
	V	2483.50	45.41	54	-8.59	Average

IEEE 802.11g mode

Channel	Polarity	Freq.(MHz)	Level(dBuV)	Limit(dBuV)	Margin(dB)	Detector
LOW	H	2390.00	60.89	74	-13.11	Peak
	H	2390.00	46.77	54	-7.23	Average
	V	2390.00	61.87	74	-12.13	Peak
	V	2390.00	46.96	54	-7.04	Average
HIGH	H	2483.50	60.19	74	-13.81	Peak
	H	2483.50	46.41	54	-7.59	Average
	V	2483.50	59.89	74	-14.11	Peak
	V	2483.50	46.23	54	-7.77	Average

**IEEE 802.11n HT20 mode**

Channel	Polarity	Freq.(MHz)	Level(dBuV)	Limit(dBuV)	Margin(dB)	Detector
LOW	H	2390.00	64.67	74	-9.33	Peak
	H	2390.00	47.11	54	-6.89	Average
	V	2390.00	65.45	74	-8.55	Peak
	V	2390.00	47.39	54	-6.61	Average
HIGH	H	2483.50	61.99	74	-12.01	Peak
	H	2483.50	46.69	54	-7.31	Average
	V	2483.50	61.64	74	-12.36	Peak
	V	2483.50	46.51	54	-7.49	Average

IEEE 802.11n HT40 mode

Channel	Polarity	Freq.(MHz)	Level(dBuV)	Limit(dBuV)	Margin(dB)	Detector
LOW	H	2390.00	66.01	74	-7.99	Peak
	H	2390.00	49.77	54	-4.23	Average
	V	2390.00	65.82	74	-8.18	Peak
	V	2390.00	51.26	54	-2.74	Average
HIGH	H	2483.50	62.31	74	-11.69	Peak
	H	2483.50	48.45	54	-5.55	Average
	V	2483.50	63.09	74	-10.91	Peak
	V	2483.50	48.69	54	-5.31	Average

Detector mode : Peak

Polarity : Horizontal

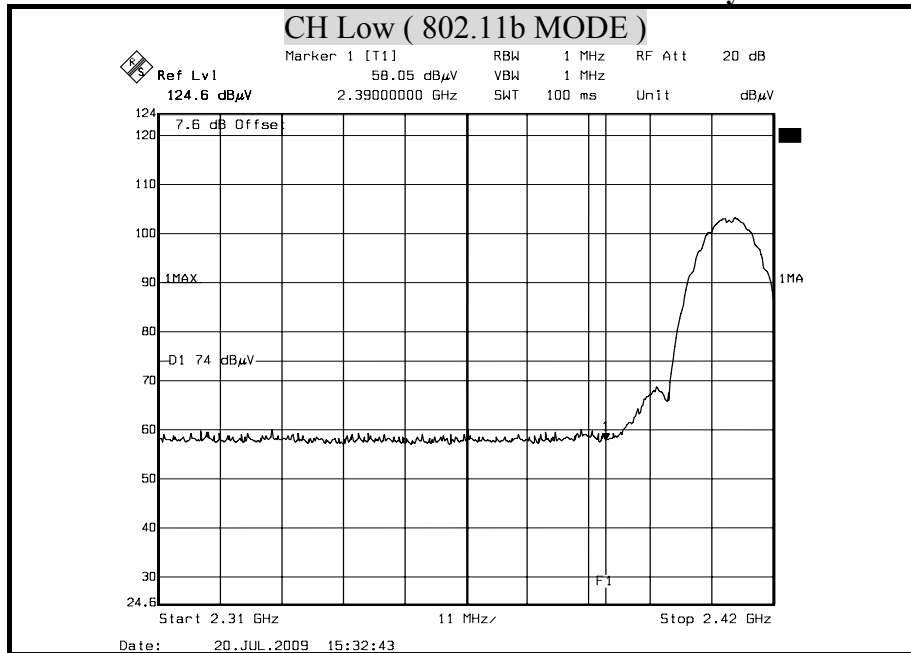

Detector mode : Average

Polarity : Horizontal

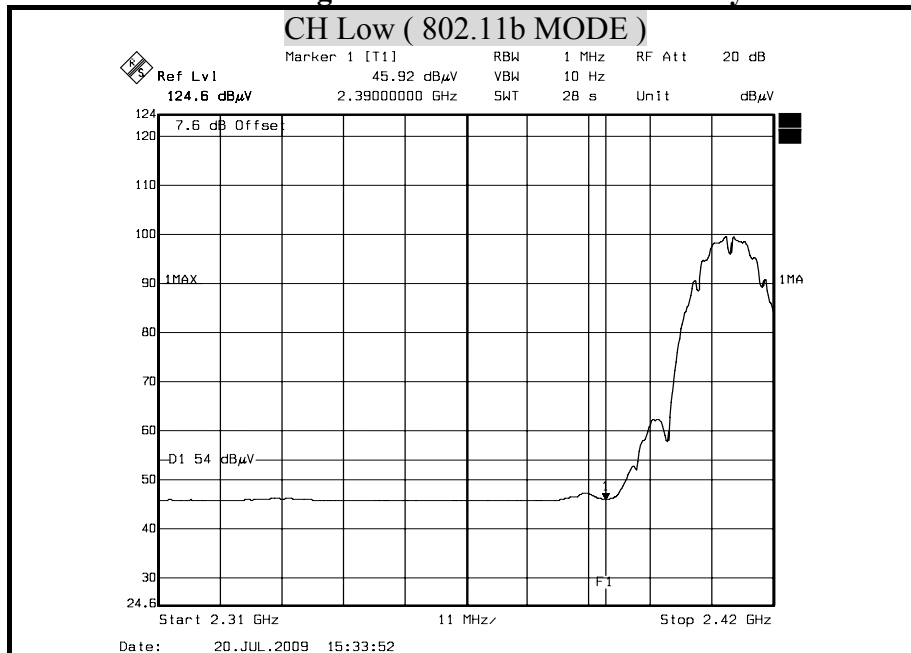

Remark:

1. Display Line = 54/74 dB µ V/m.
2. 2390MHz Offset(dB) = Antenna Factor(dB/m) + Cable Loss(dB) - Pre-Amplifier(dB) + Attenuator(dB)=7.6(dB)
3. 2483.5MHz Offset(dB) = Antenna Factor(dB/m) + Cable Loss(dB) - Pre-Amplifier(dB) + Attenuator(dB)=7.62(dB)

Detector mode : Peak

Polarity : Vertical

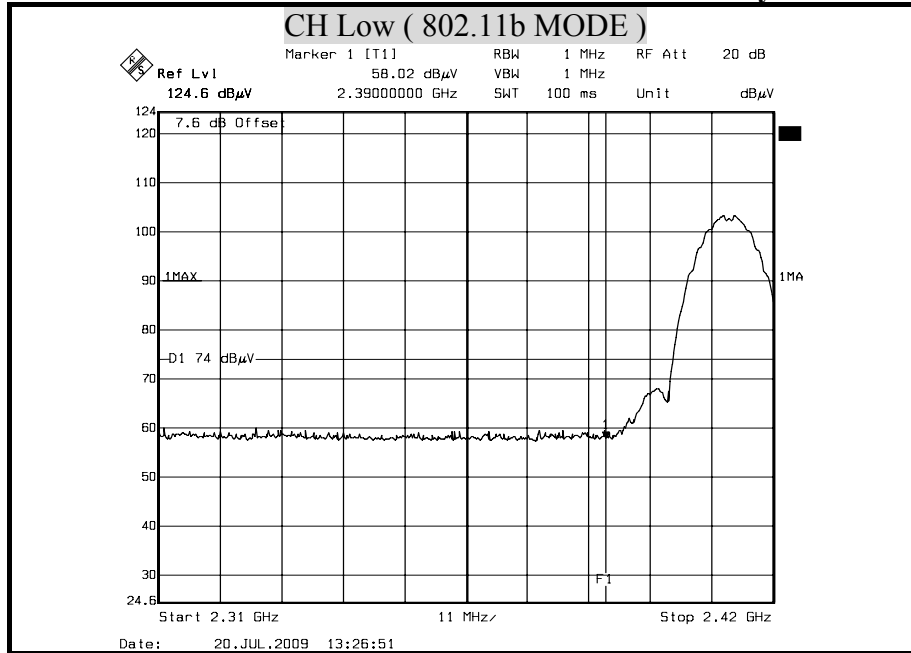

Detector mode : Average

Polarity : Vertical

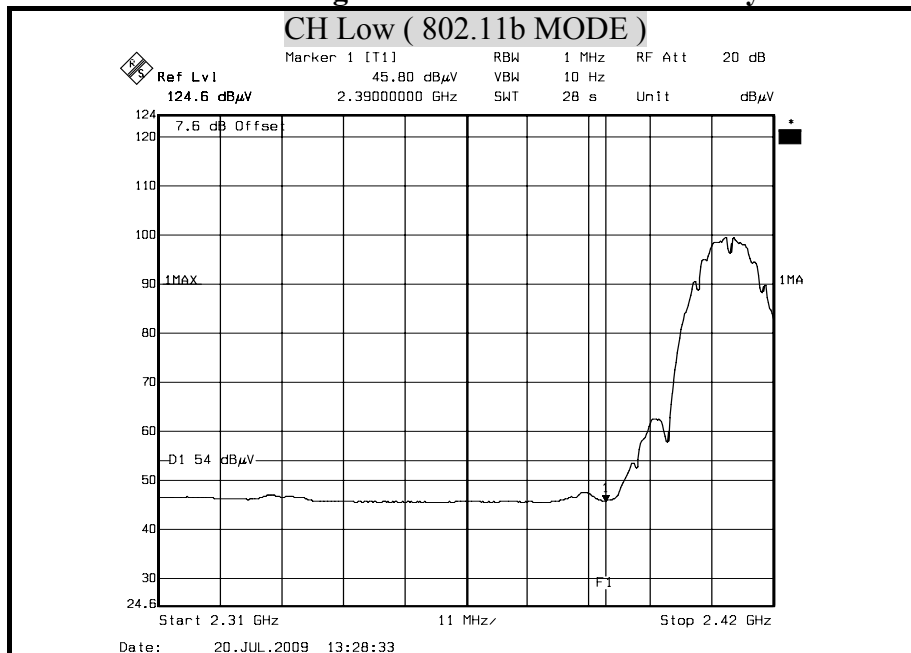

Remark:

1. Display Line = 54/74 dB μ V/m.
2. 2390MHz Offset(dB) = Antenna Factor(dB/m) + Cable Loss(dB) - Pre-Amplifier(dB) + Attenuator(dB)=7.6(dB)
3. 2483.5MHz Offset(dB) = Antenna Factor(dB/m) + Cable Loss(dB) - Pre-Amplifier(dB) + Attenuator(dB)=7.62(dB)

Detector mode : Peak **Polarity : Horizontal**

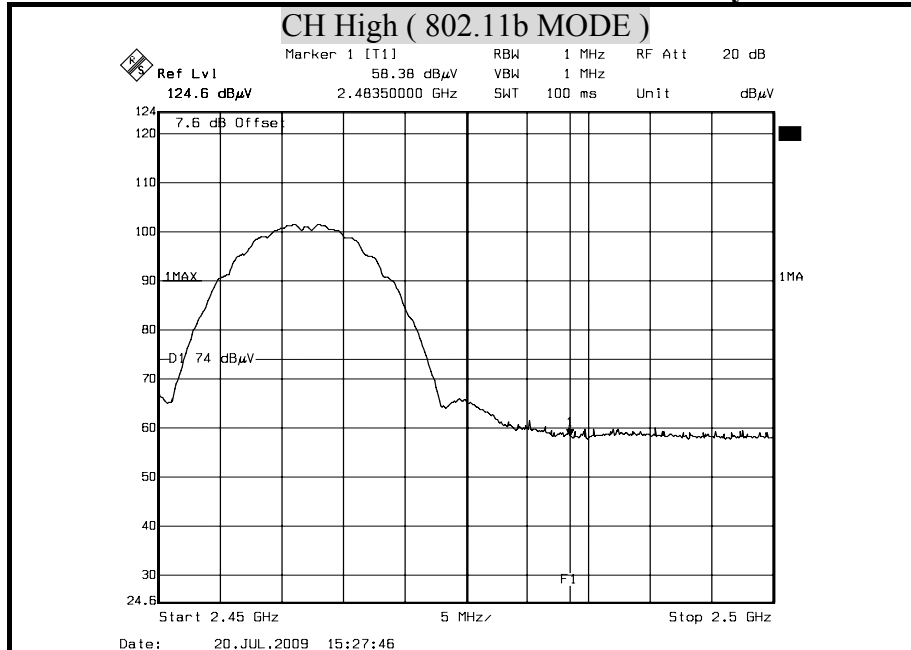

Detector mode : Average **Polarity : Horizontal**

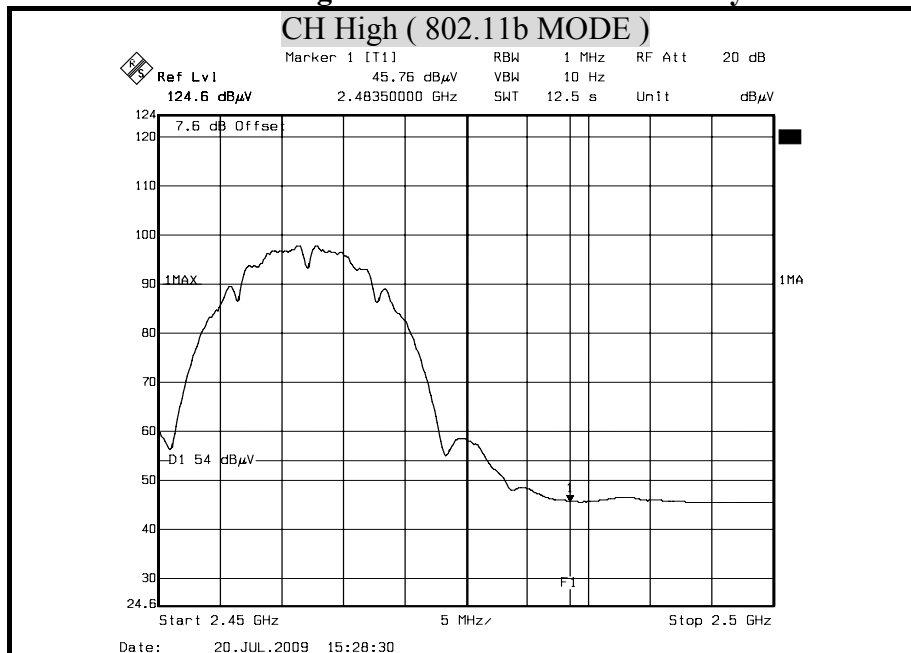

Remark:

1. Display Line = 54/74 dB μ V/m.
2. 2390MHz Offset(dB) = Antenna Factor(dB/m) + Cable Loss(dB) - Pre-Amplifier(dB) + Attenuator(dB)=7.6(dB)
3. 2483.5MHz Offset(dB) = Antenna Factor(dB/m) + Cable Loss(dB) - Pre-Amplifier(dB) + Attenuator(dB)=7.62(dB)

Detector mode : Peak

Polarity : Vertical

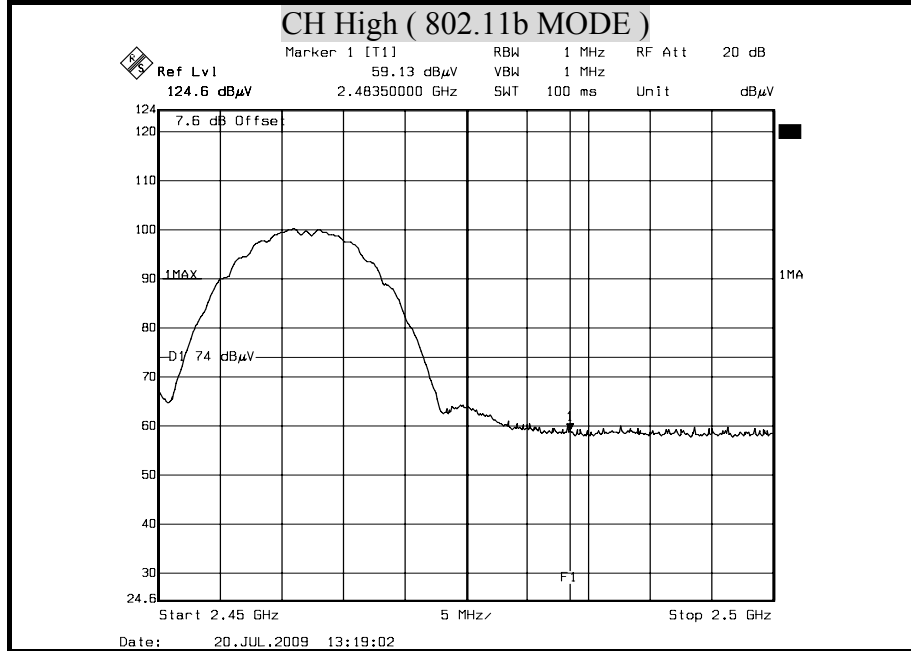

Detector mode : Average

Polarity : Vertical

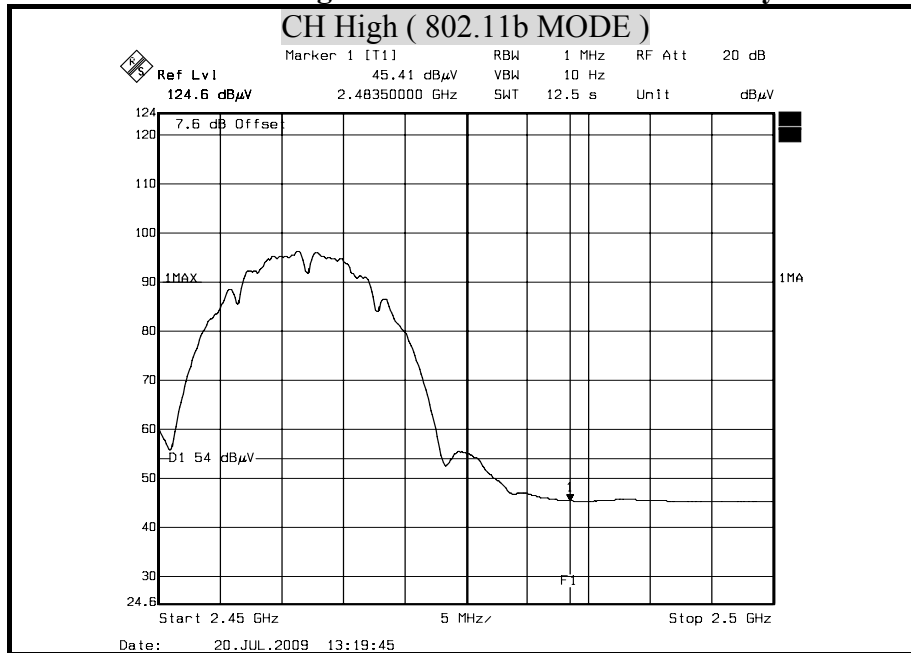

Remark:

1. Display Line = 54/74 dB μ V/m.
2. 2390MHz Offset(dB) = Antenna Factor(dB/m) + Cable Loss(dB) - Pre-Amplifier(dB) + Attenuator(dB)=7.6(dB)
3. 2483.5MHz Offset(dB) = Antenna Factor(dB/m) + Cable Loss(dB) - Pre-Amplifier(dB) + Attenuator(dB)=7.62(dB)



Detector mode : Peak

Polarity : Horizontal

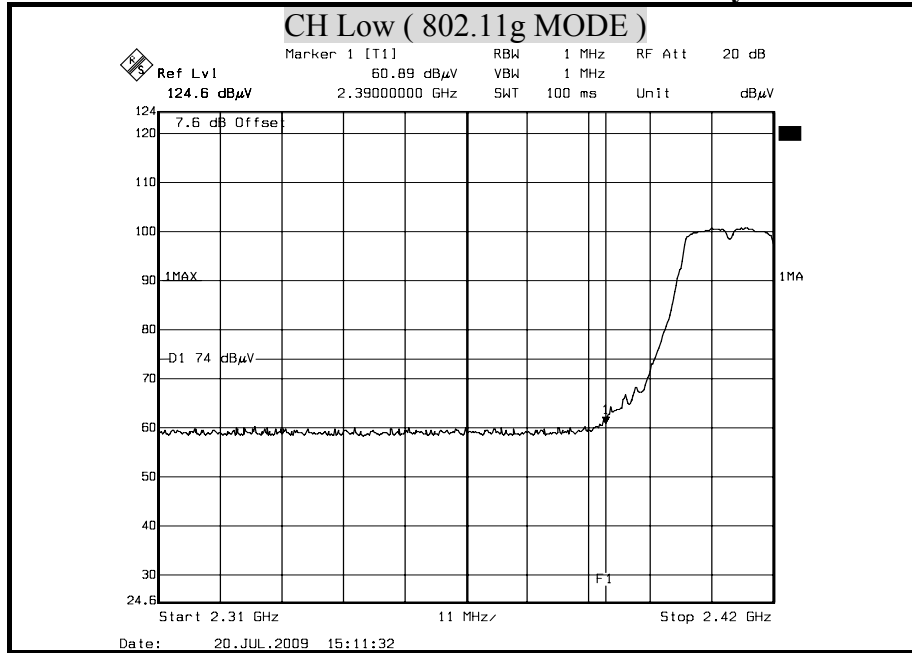

Detector mode : Average

Polarity : Horizontal

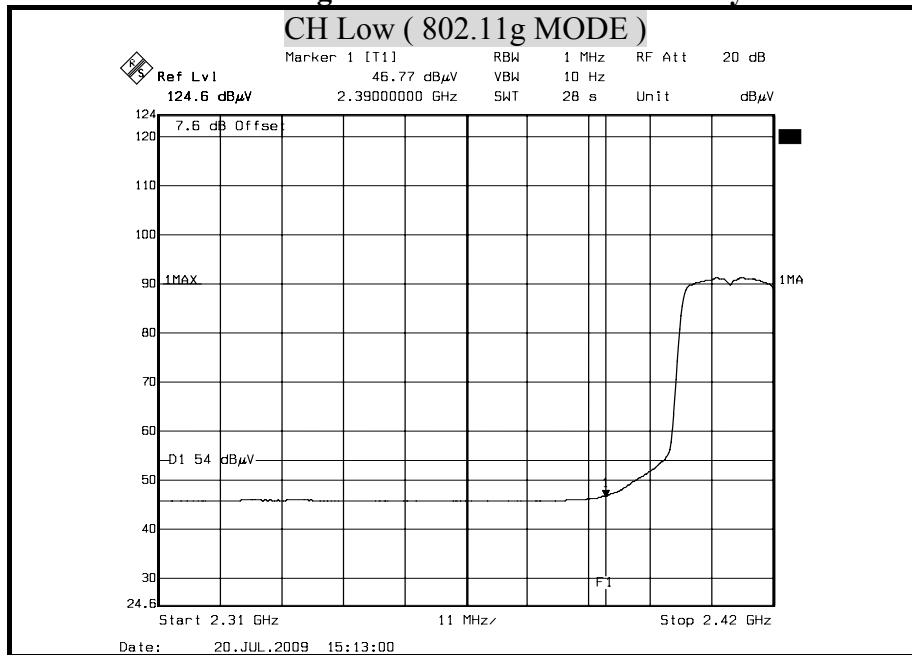

Remark:

1. Display Line = 54/74 dB μ V/m.
2. 2390MHz Offset(dB) = Antenna Factor(dB/m) + Cable Loss(dB) - Pre-Amplifier(dB) + Attenuator(dB)=7.6(dB)
3. 2483.5MHz Offset(dB) = Antenna Factor(dB/m) + Cable Loss(dB) - Pre-Amplifier(dB) + Attenuator(dB)=7.62(dB)

Detector mode : Peak

Polarity : Vertical

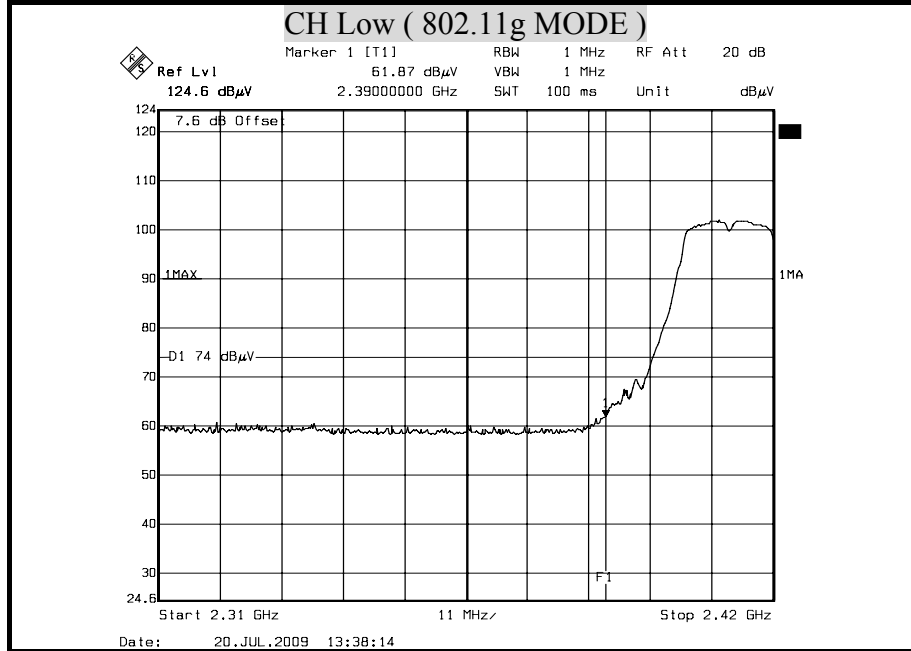

Detector mode : Average

Polarity : Vertical

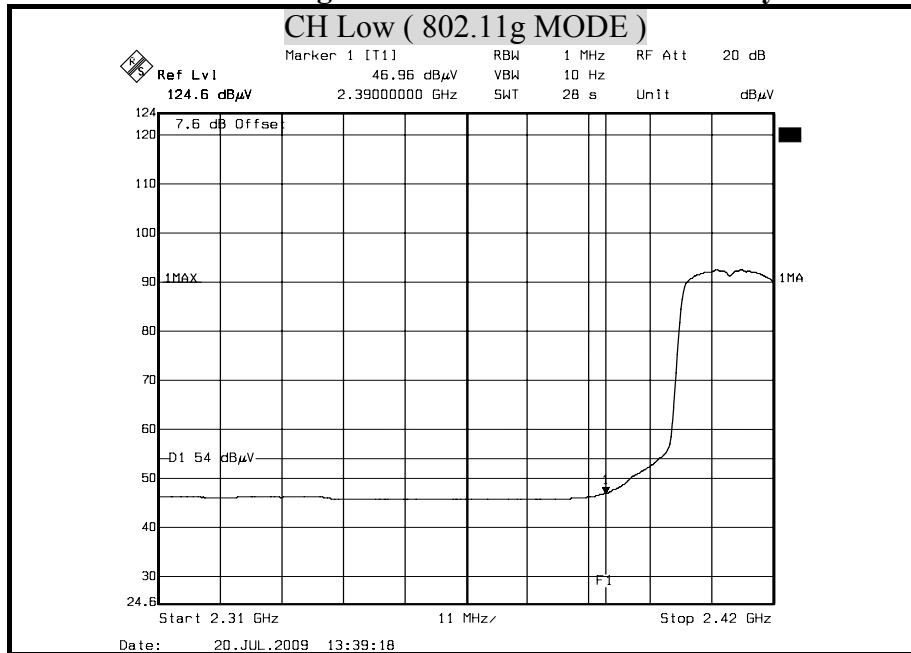

Remark:

1. Display Line = 54/74 dB μ V/m.
2. 2390MHz Offset(dB) = Antenna Factor(dB/m) + Cable Loss(dB) - Pre-Amplifier(dB) + Attenuator(dB)=7.6(dB)
3. 2483.5MHz Offset(dB) = Antenna Factor(dB/m) + Cable Loss(dB) - Pre-Amplifier(dB) + Attenuator(dB)=7.62(dB)

Detector mode : Peak

Polarity : Horizontal

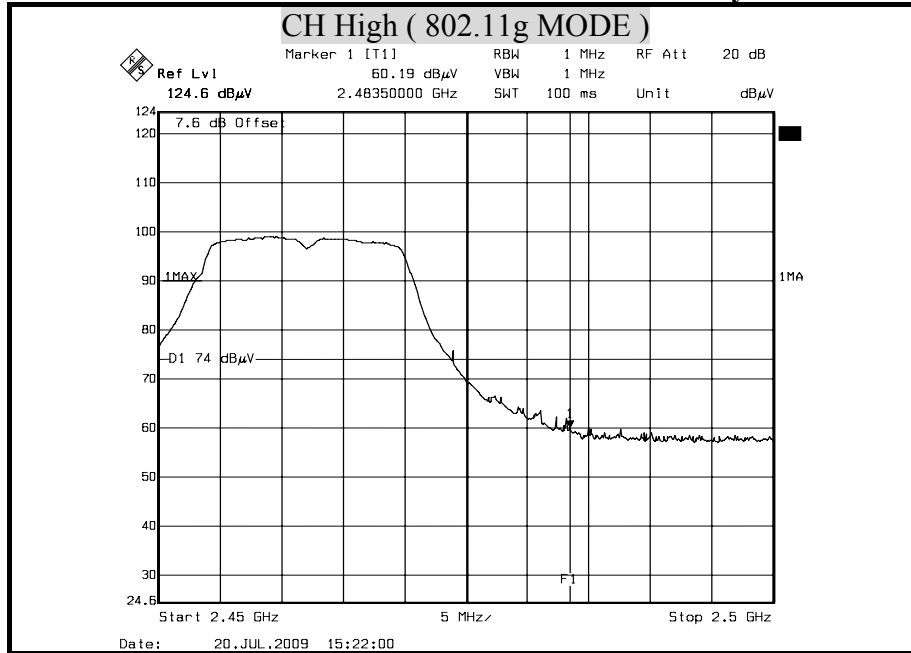

Detector mode : Average

Polarity : Horizontal

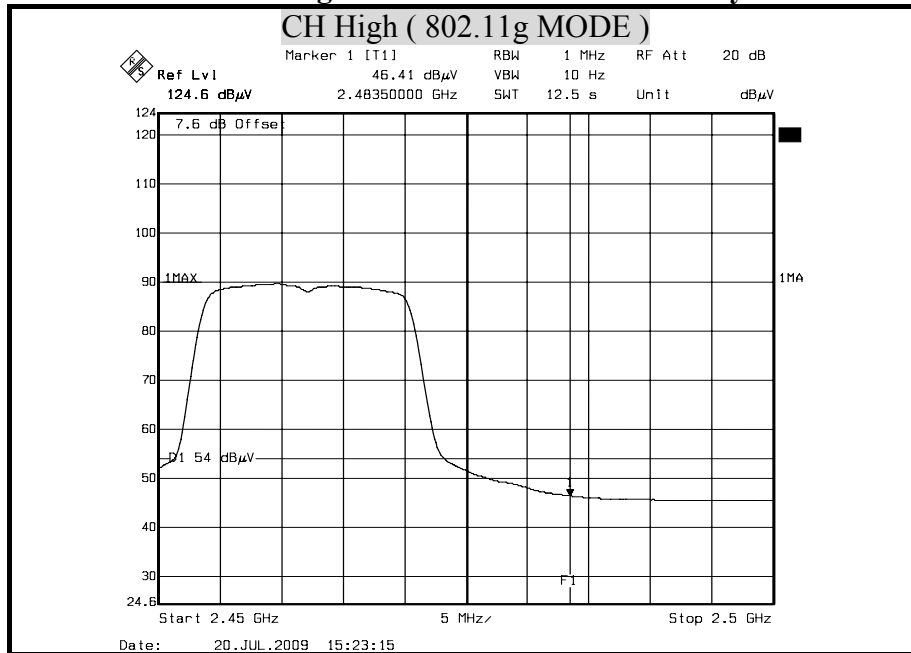

Remark:

1. Display Line = 54/74 dB μ V/m.
2. 2390MHz Offset(dB) = Antenna Factor(dB/m) + Cable Loss(dB) - Pre-Amplifier(dB) + Attenuator(dB)=7.6(dB)
3. 2483.5MHz Offset(dB) = Antenna Factor(dB/m) + Cable Loss(dB) - Pre-Amplifier(dB) + Attenuator(dB)=7.62(dB)

Detector mode : Peak

Polarity : Vertical

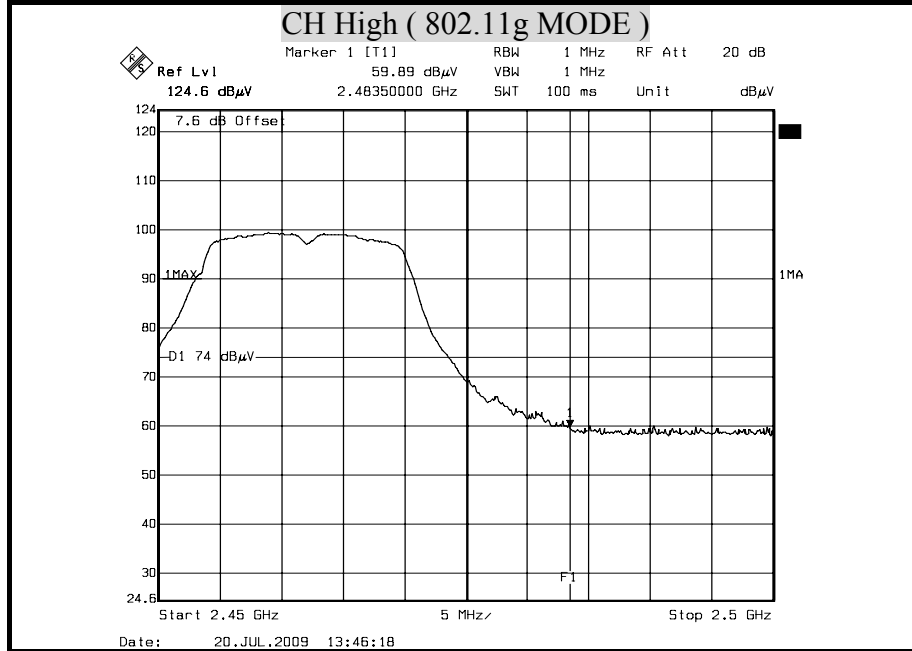

Detector mode : Average

Polarity : Vertical

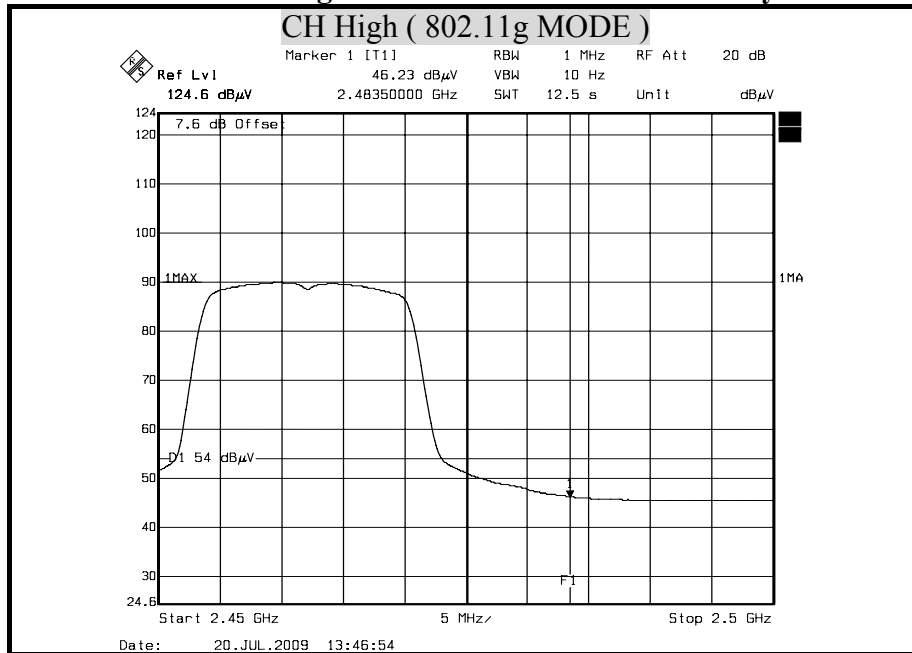

Remark:

1. Display Line = 54/74 dB µ V/m.
2. 2390MHz Offset(dB) = Antenna Factor(dB/m) + Cable Loss(dB) - Pre-Amplifier(dB) + Attenuator(dB)=7.6(dB)
3. 2483.5MHz Offset(dB) = Antenna Factor(dB/m) + Cable Loss(dB) - Pre-Amplifier(dB) + Attenuator(dB)=7.62(dB)

Detector mode : Peak

Polarity : Vertical

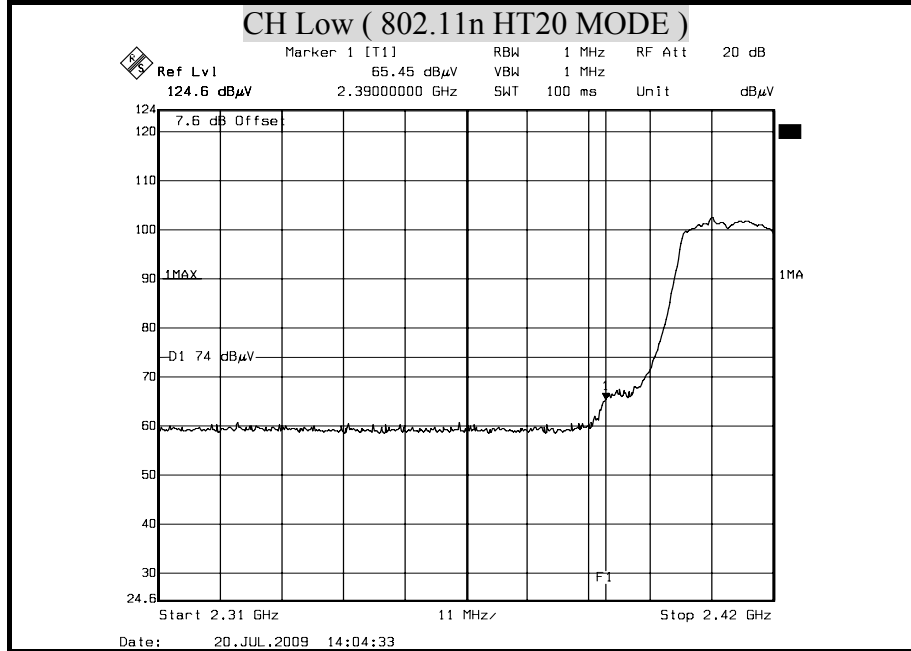

Detector mode : Average

Polarity : Vertical

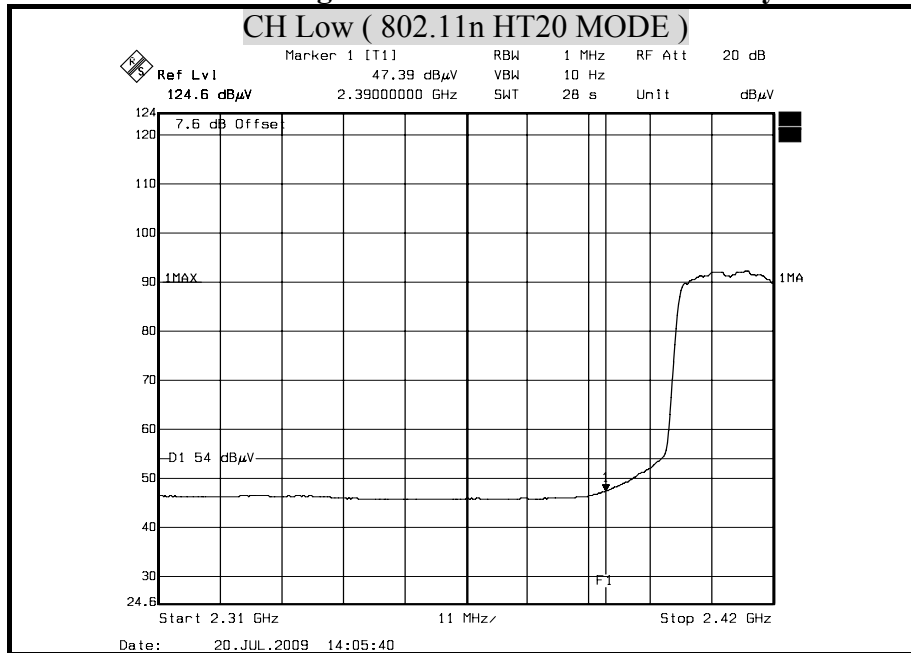

Remark:

1. Display Line = $54/74 \text{ dB } \mu \text{V/m}$.
2. $2390\text{MHz Offset(dB)} = \text{Antenna Factor(dB/m)} + \text{Cable Loss(dB)} - \text{Pre-Amplifier(dB)} + \text{Attenuator(dB)} = 7.6(\text{dB})$
3. $2483.5\text{MHz Offset(dB)} = \text{Antenna Factor(dB/m)} + \text{Cable Loss(dB)} - \text{Pre-Amplifier(dB)} + \text{Attenuator(dB)} = 7.62(\text{dB})$

Detector mode : Peak **Polarity : Horizontal**

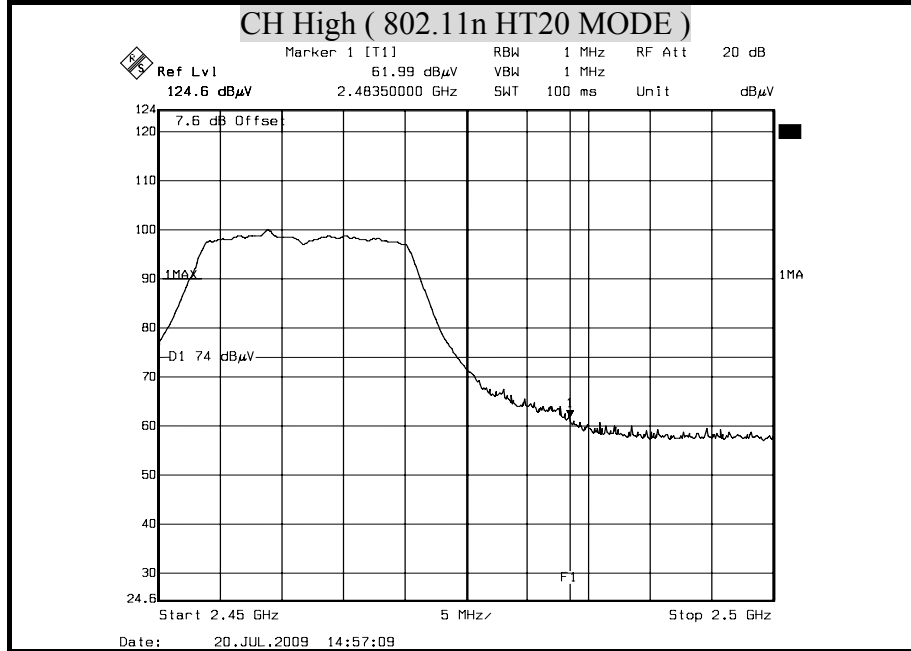

Detector mode : Average **Polarity : Horizontal**

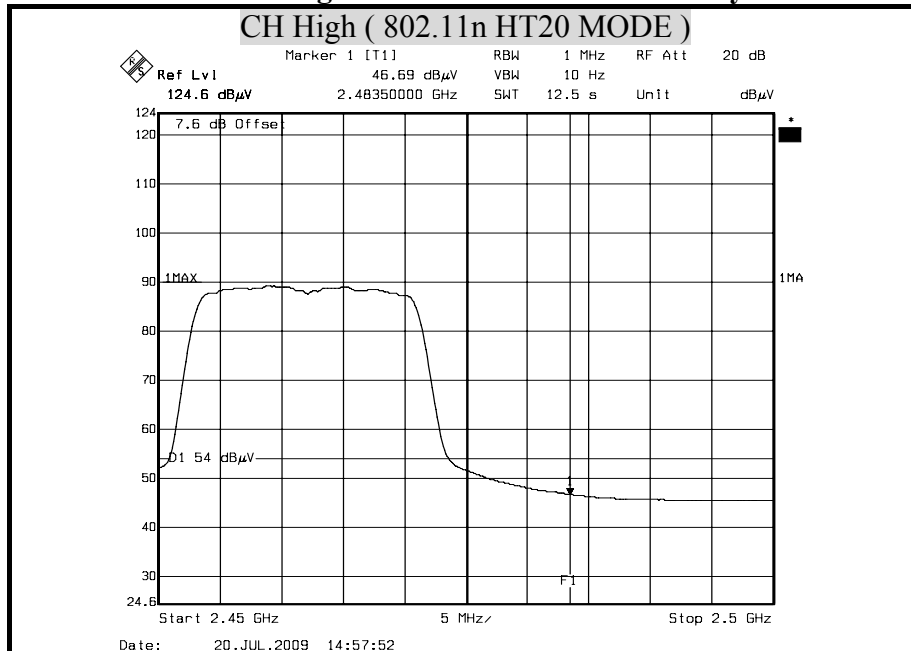

Remark:

1. Display Line = 54/74 dB μ V/m.
2. 2390MHz Offset(dB) = Antenna Factor(dB/m) + Cable Loss(dB) - Pre-Amplifier(dB) + Attenuator(dB)=7.6(dB)
3. 2483.5MHz Offset(dB) = Antenna Factor(dB/m) + Cable Loss(dB) - Pre-Amplifier(dB) + Attenuator(dB)=7.62(dB)

Detector mode : Peak

Polarity : Vertical

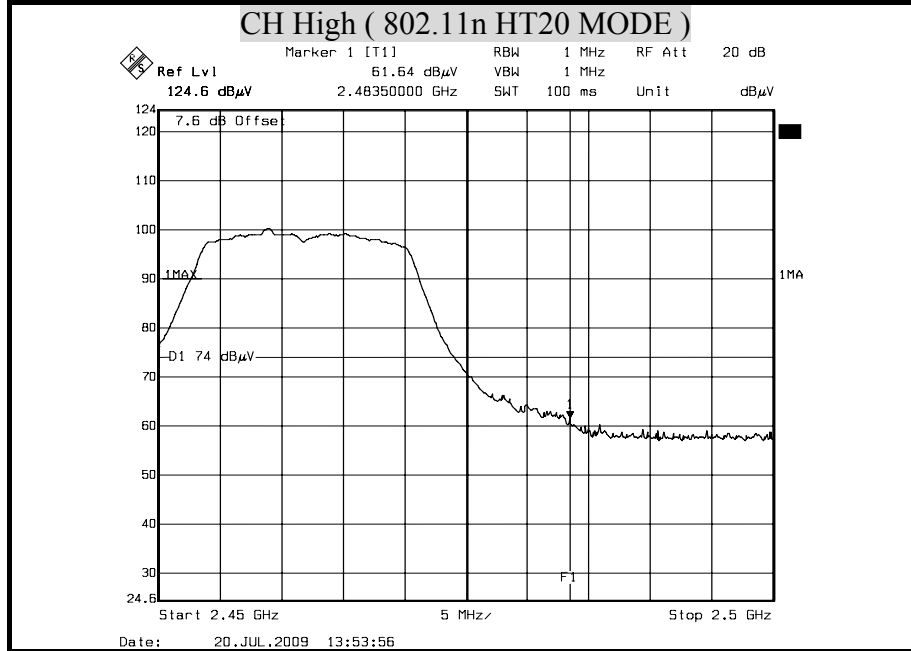

Detector mode : Average

Polarity : Vertical

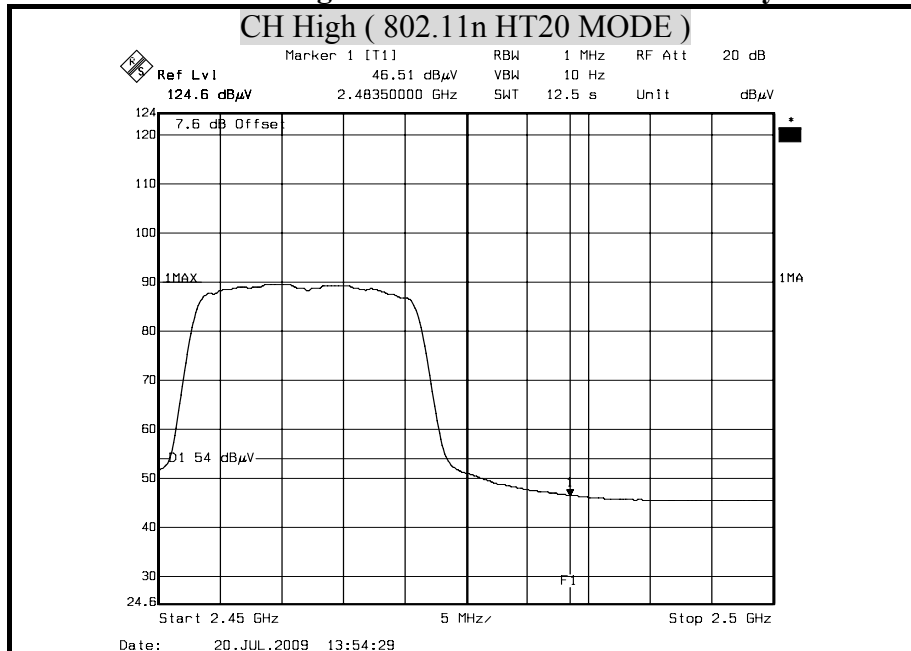

Remark:

1. Display Line = 54/74 dB μ V/m.
2. 2390MHz Offset(dB) = Antenna Factor(dB/m) + Cable Loss(dB) - Pre-Amplifier(dB) + Attenuator(dB)=7.6(dB)
3. 2483.5MHz Offset(dB) = Antenna Factor(dB/m) + Cable Loss(dB) - Pre-Amplifier(dB) + Attenuator(dB)=7.62(dB)

Detector mode : Peak **Polarity : Horizontal**

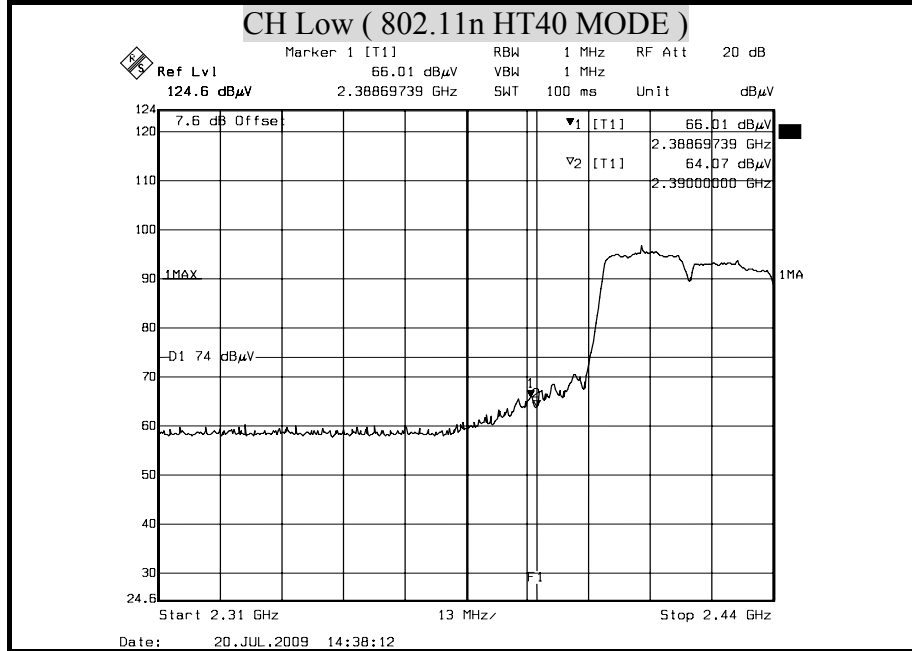

Detector mode : Average **Polarity : Horizontal**

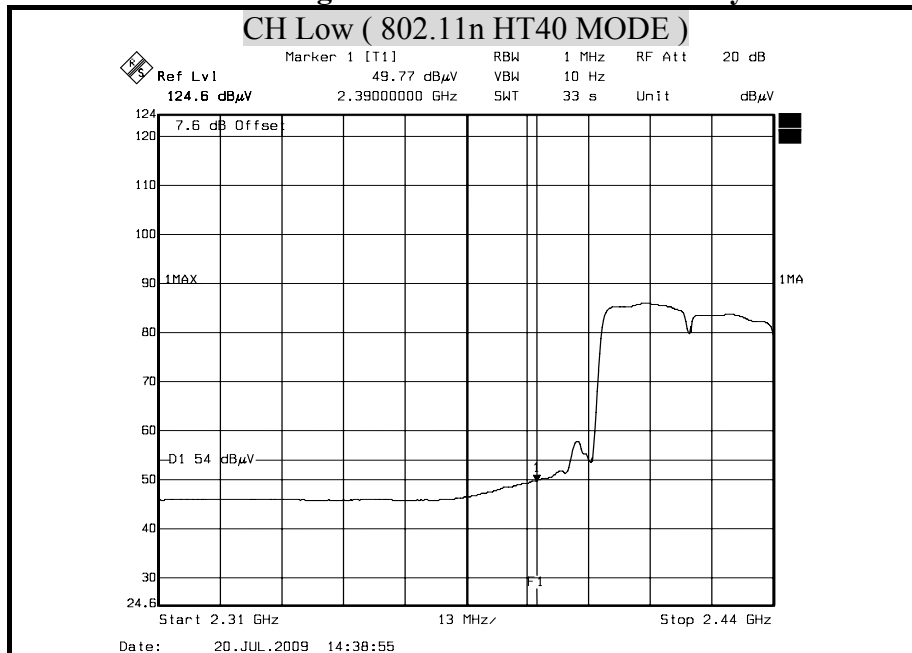

Remark:

1. Display Line = 54/74 dB μ V/m.
2. 2390MHz Offset(dB) = Antenna Factor(dB/m) + Cable Loss(dB) - Pre-Amplifier(dB) + Attenuator(dB)=7.6(dB)
3. 2483.5MHz Offset(dB) = Antenna Factor(dB/m) + Cable Loss(dB) - Pre-Amplifier(dB) + Attenuator(dB)=7.62(dB)



Detector mode : Peak **Polarity : Vertical**

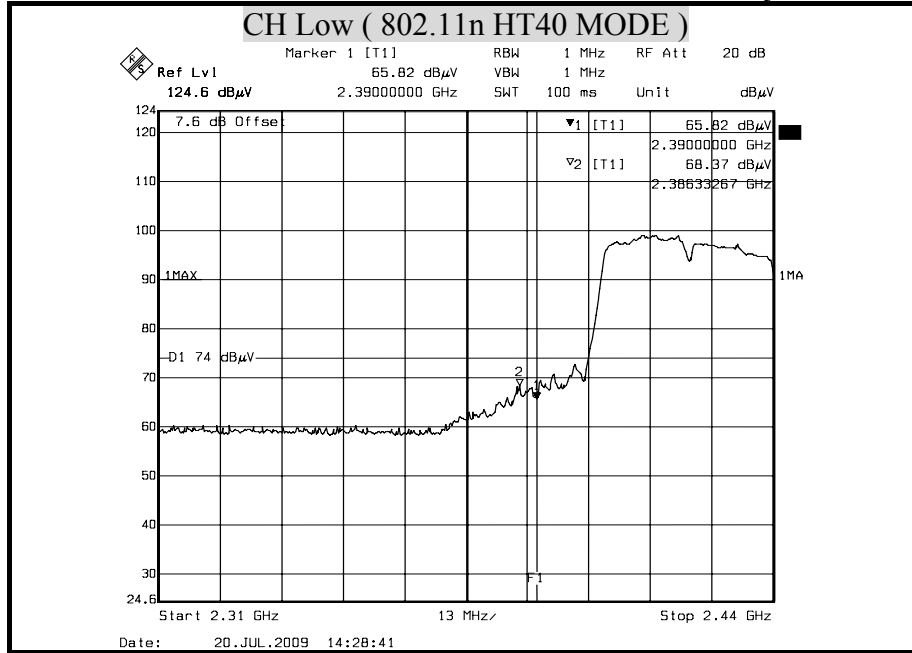

Detector mode : Average **Polarity : Vertical**

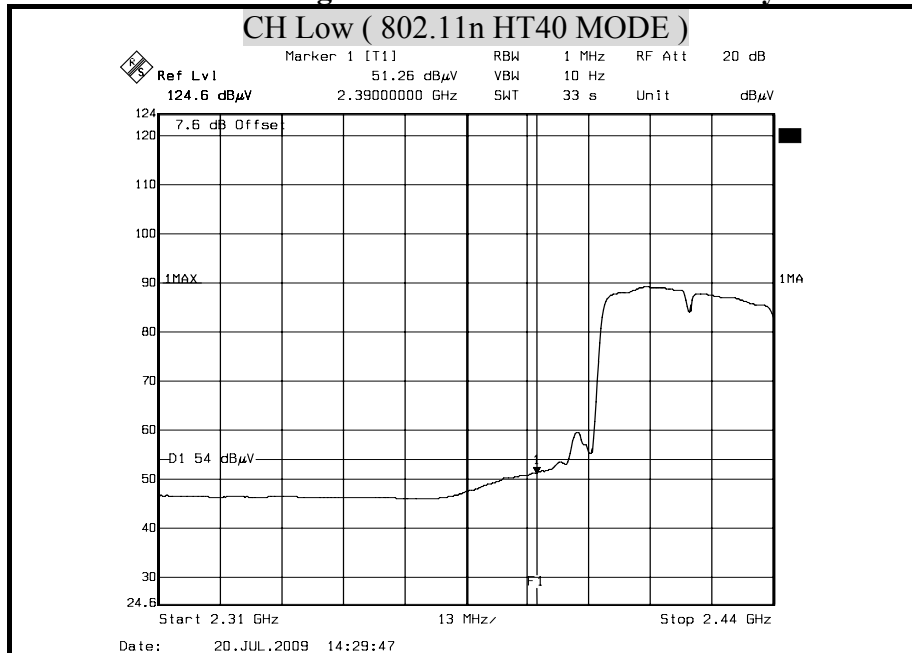

Remark:

1. Display Line = 54/74 dB μ V/m.
2. 2390MHz Offset(dB) = Antenna Factor(dB/m) + Cable Loss(dB) - Pre-Amplifier(dB) + Attenuator(dB)=7.6(dB)
3. 2483.5MHz Offset(dB) = Antenna Factor(dB/m) + Cable Loss(dB) - Pre-Amplifier(dB) + Attenuator(dB)=7.62(dB)

Detector mode : Peak

Polarity : Horizontal

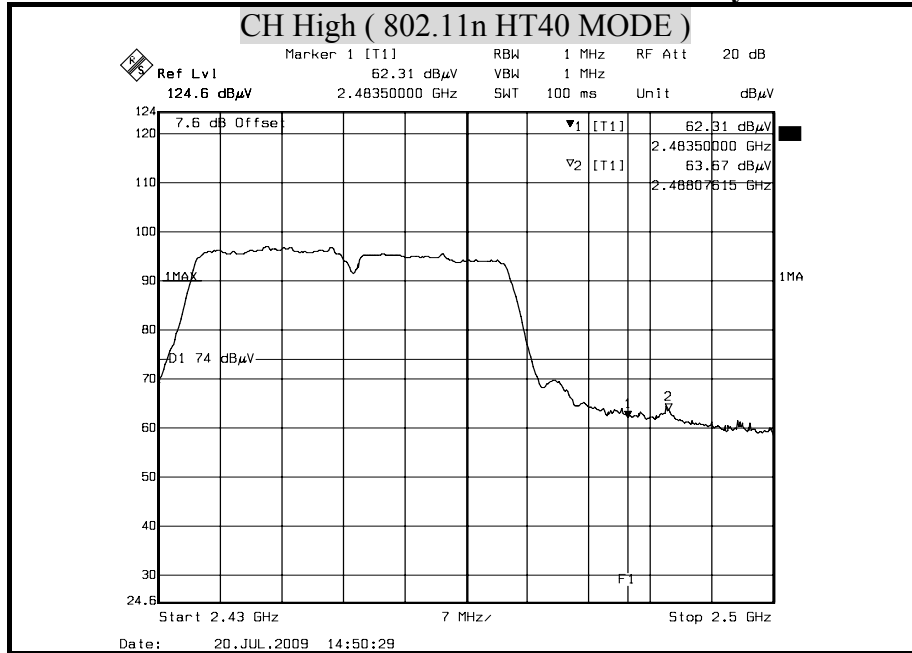

Detector mode : Average

Polarity : Horizontal

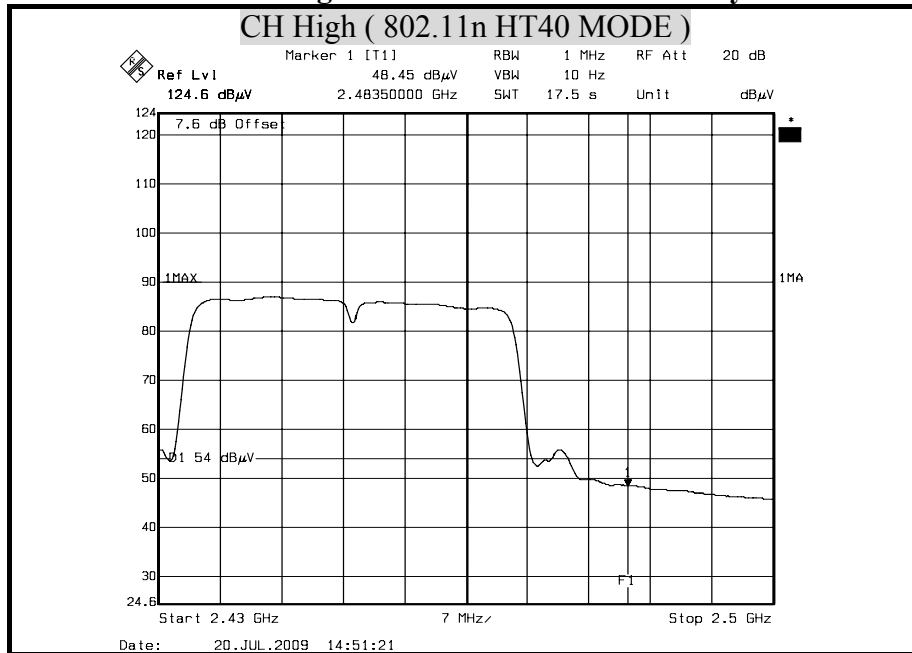

Remark:

1. Display Line = 54/74 dB µ V/m.
2. 2390MHz Offset(dB) = Antenna Factor(dB/m) + Cable Loss(dB) - Pre-Amplifier(dB) + Attenuator(dB)=7.6(dB)
3. 2483.5MHz Offset(dB) = Antenna Factor(dB/m) + Cable Loss(dB) - Pre-Amplifier(dB) + Attenuator(dB)=7.62(dB)

Detector mode : Peak

Polarity : Vertical

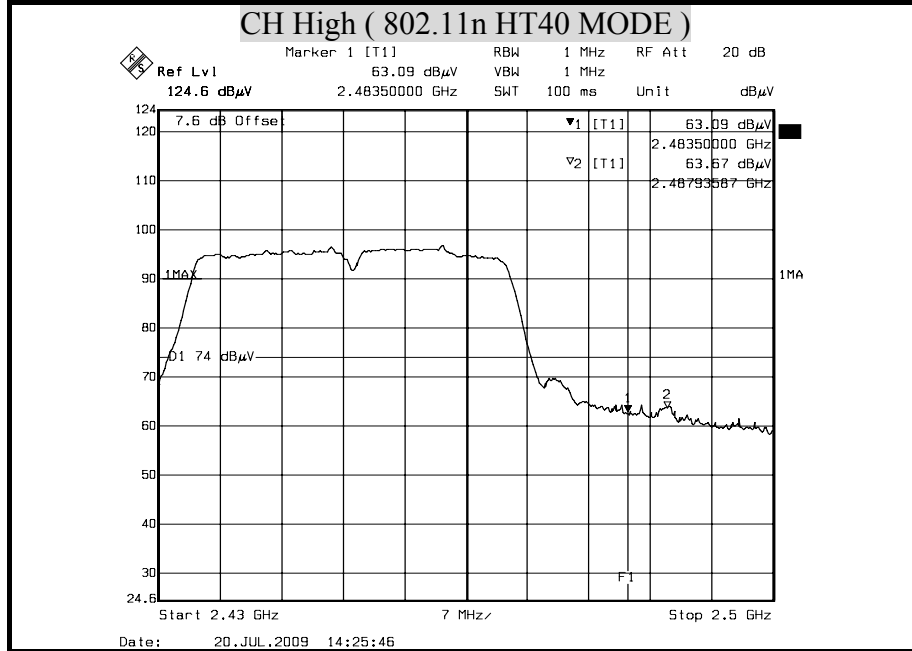

Detector mode : Average

Polarity : Vertical

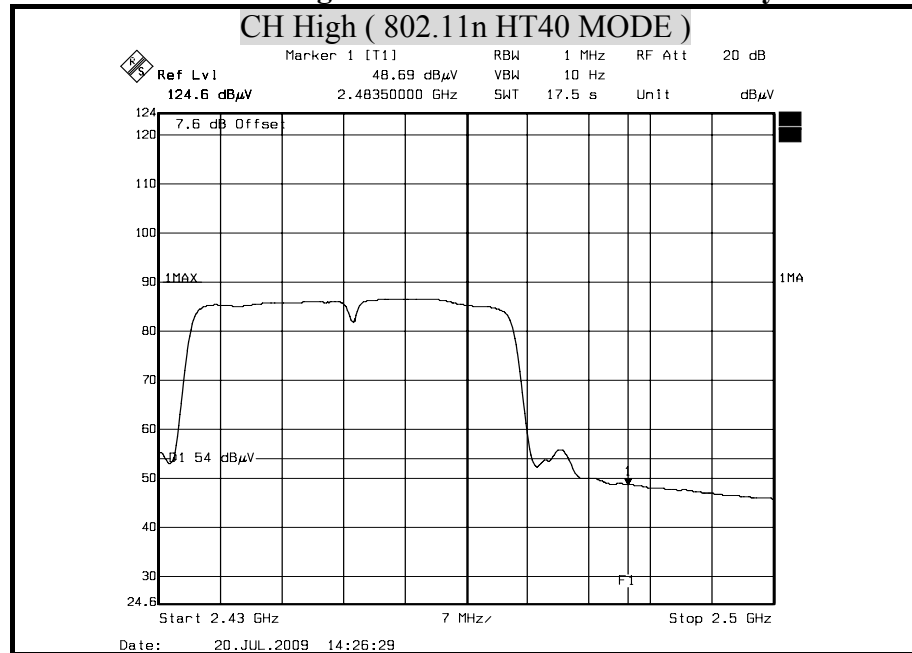

Remark:

1. Display Line = 54/74 dB μ V/m.
2. 2390MHz Offset(dB) = Antenna Factor(dB/m) + Cable Loss(dB) - Pre-Amplifier(dB) + Attenuator(dB)=7.6(dB)
3. 2483.5MHz Offset(dB) = Antenna Factor(dB/m) + Cable Loss(dB) - Pre-Amplifier(dB) + Attenuator(dB)=7.62(dB)



8.7 POWERLINE CONDUCTED EMISSIONS

LIMITS

§ 15.207 (a) Except as shown in paragraph (b) and (c) this section, for an intentional radiator that is designed to be connected to the public utility (AC) power line, the radio frequency voltage that is conducted back onto the AC power line on any frequency or frequencies within the band 150 kHz to 30 MHz shall not exceed the limits in the following table, as measured using a 50 μ H/50 ohms line impedance stabilization network (LISN). Compliance with the provisions of this paragraph shall be based on the measurement of the radio frequency voltage between each power line and ground at the power terminal.

The lower limit applies at the boundary between the frequency ranges.

Frequency of Emission (MHz)	Conducted limit (dB μ v)	
	Quasi-peak	Average
0.15 - 0.5	66 to 56	56 to 46
0.5 - 5	56	46
5 - 30	60	50

TEST EQUIPMENTS

The following test equipments are used during the conducted power line tests:

Conducted Emission room #1				
Name of Equipment	Manufacturer	Model	Serial Number	Calibration Due
L.I.S.N.	SCHWARZBECK	NNLK 8121	8121-446	NOV. 19, 2009 For Insertion loss
	Rohde & Schwarz	ESH 3-Z5	840062/021	OCT. 05, 2009
TEST RECEIVER	Rohde & Schwarz	ESCS 30	100348	JUL. 02, 2010
TYPE N COAXIAL CABLE	SUHNER	BELDEN991 3	2981	JAN. 14, 2010
Test S/W	e-3 (5.04211c) R&S (2.27)			

TEST SETUP

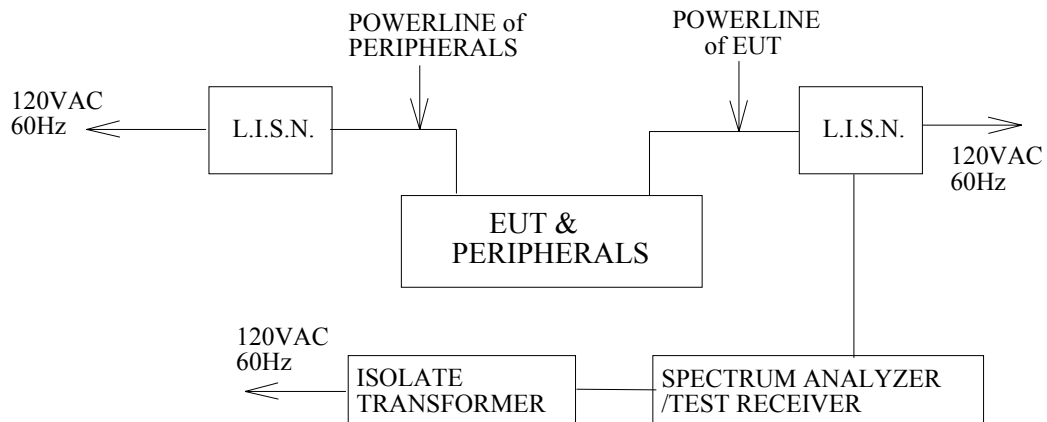

TEST PROCEDURE

The EUT is placed on a non-conducting table 40 cm from the vertical ground plane and 80cm above the horizontal ground plane. The EUT IS CONFIGURED IN ACCORDANCE WITH ANSI C63.4.

The resolution bandwidth is set to 9 kHz for both quasi-peak detection and average detection measurements.

Line conducted data is recorded for both NEUTRAL and LINE.

TEST RESULTS

No non-compliance noted.



CONDUCTED RF VOLTAGE MEASUREMENT

Product Name	11n Wireless Server Router	Test Date	2009/6/9
Model	3R161N	Test By	Taiyu Cyu
Test Mode	Normal operating / worst case	TEMP & Humidity	26°C, 60%

LINE

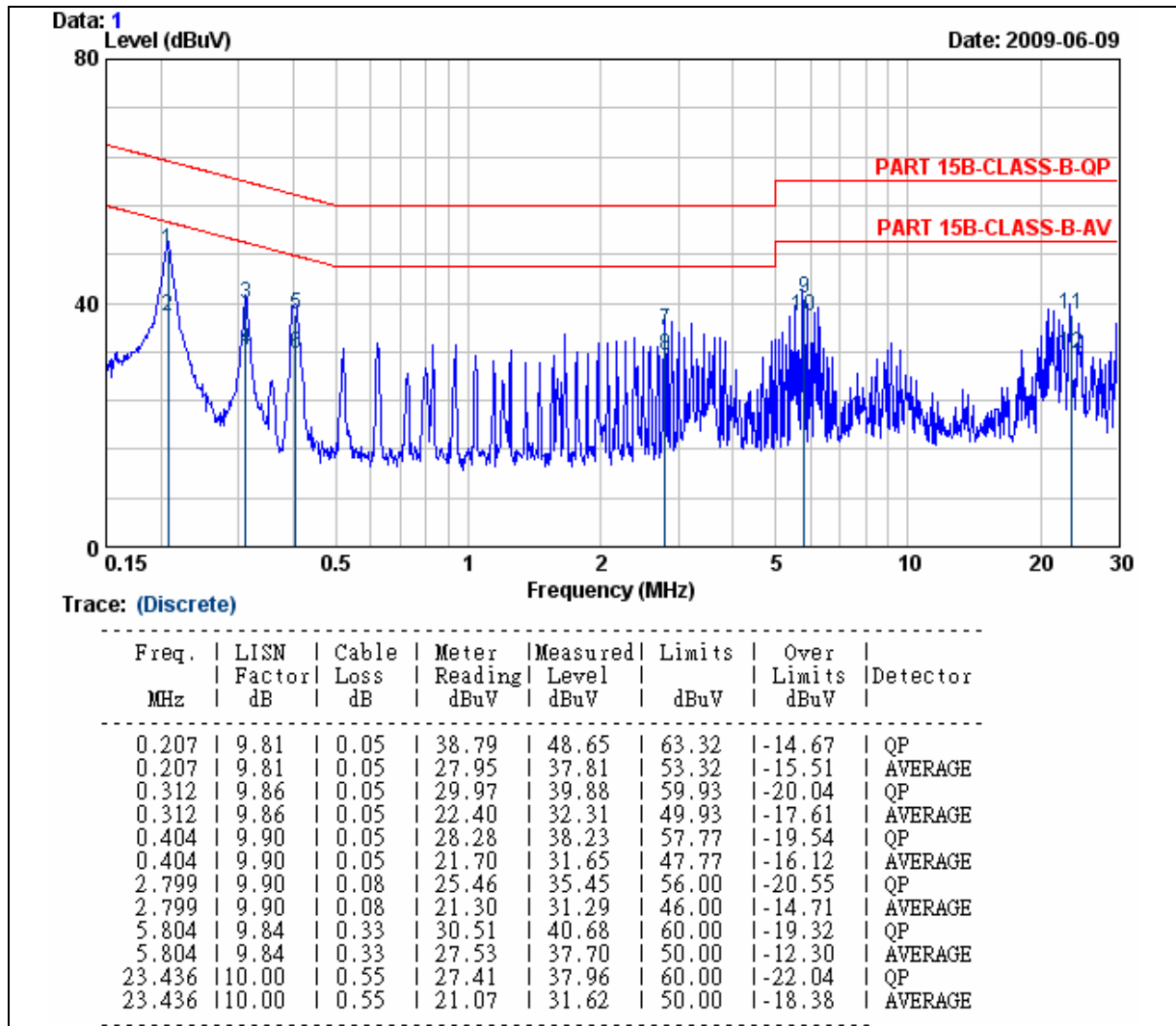

REMARK:

1. Correction Factor = Insertion loss + cable loss
2. Margin value = Emission level – Limit value



Product Name	11n Wireless Server Router	Test Date	2009/6/9
Model	3R161N	Test By	Taiyu Cyu
Test Mode	Normal operating / worst case	TEMP & Humidity	26°C, 60%

NEUTRAL

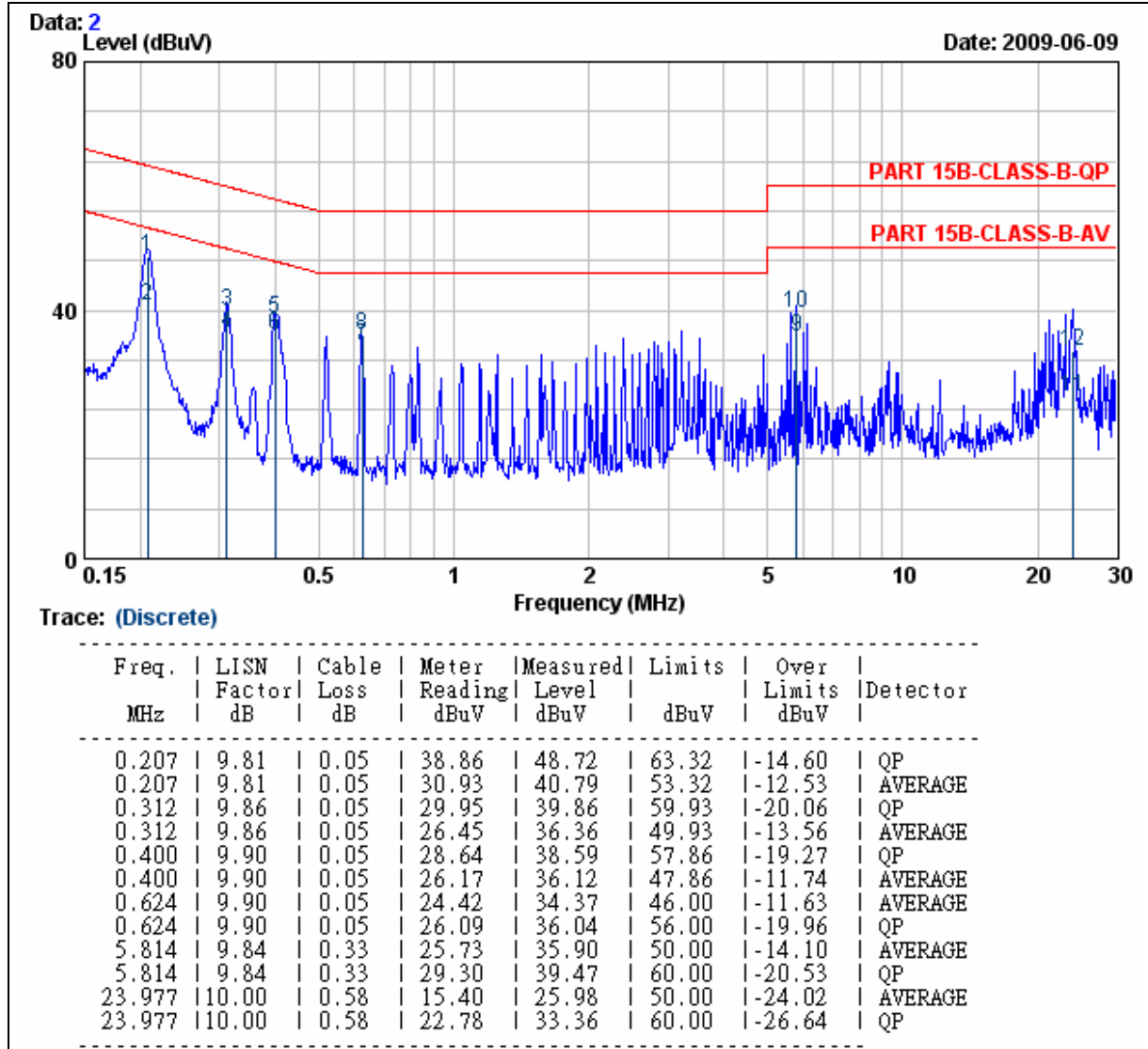

REMARK:

1. Correction Factor = Insertion loss + cable loss
2. Margin value = Emission level – Limit value



9. ANTENNA REQUIREMENT

9.1 STANDARD APPLICABLE

For intentional device, according to FCC 47 CFR Section 15.203, an intentional radiator shall be designed to ensure that no antenna other than that furnished by the responsible party shall be used with the device.

And according to FCC 47 CFR Section 15.247 (b), if transmitting antennas of directional gain greater than 6dBi are used, the power shall be reduced by the amount in dB that the directional gain of the antenna exceeds 6dBi.

9.2 ANTENNA CONNECTED CONSTRUCTION

Two antennas 1Tx 2Rx

I-PEX PIFA Antenna (× 1) 1TX1RX

Manufacture: SOCAA CORP. LTD.

Model: 9806118-A

Connector: I-PEX

Type: PIFA

Gain: 2.0 dBi

Printed Antenna (× 1) 1RX

Gain: 0 dBi