



# RBAND

MONITORED GATE EDGE TRANSMITTER/RECEIVER

## INSTALLATION INSTRUCTIONS

Models: RB-G-K10, RB-TX10

In partnership with



MillerEdge®

### IMPORTANT: THIS DEVICE MUST BE PROFESSIONALLY INSTALLED READ AND UNDERSTAND ALL INSTRUCTIONS BEFORE BEGINNING INSTALLATION

The Miller Edge RBand Monitored Gate Edge Transmitter/Receiver system is intended to provide a wireless connection between a monitored sensing edge and a motorized operator that controls the associated gate. The RBand Receiver is compatible with up to 3 RBand Transmitters on 2 channels; 6 total transmitters. RBand meets the 2016 UL 325 requirements for monitored devices and has been certified as a UL 325 Recognized Component. It is designed for use with operators that comply with 2016 UL 325 using a Miller Edge 10K Sensing Edge.

## 1. PARTS LIST

### RB-G-K10 Contents:

- RBand Gate Edge Transmitter/Receiver System:
  - RBand Edge Transmitter (RB-TX10)
  - RBand Gate Edge Receiver (RB-G-RX10)
- Receiver antenna
- (2) 3.6V AA lithium batteries\*
- (4) #6 pan head transmitter mounting screws

### RB-TX10 Contents:

- RBand Gate Edge Transmitter (RB-TX10)
- (2) 3.6V AA lithium batteries\*
- (4) #6 pan head transmitter mounting screws

\*Replacement **3.6V AA lithium batteries** can be purchased at your local electronics store or via Miller Edge.

### Required:

- 1/8" flat blade screwdriver
- 1/4" flat blade screwdriver
- Miller Edge 10K (T2/blue band) Sensing Edge
- Coaxial cable for exterior mounted antenna
- Coaxial bulkhead adapter, female/female

### Recommended:

- Multi-meter capable of reading 10KΩ
- Mounting screws as required for receiver

## 2. RECEIVER: INSTALLATION

1. Remove the operator cover and turn off the power to the gate operator.
2. Determine where to place the external mounted antenna so it is in line of sight with the Transmitter(s) for the entire range of travel [IMAGE 1]. Prepare the antenna coax as necessary.
3. Remove the Receiver cover and mount the base inside the operator, positioning it for optimum ease of wiring.
4. Connect power to the terminals marked **12/24 AC/DC** (polarity sensitive) on the **removable 8-pin connector** [IMAGE 2].

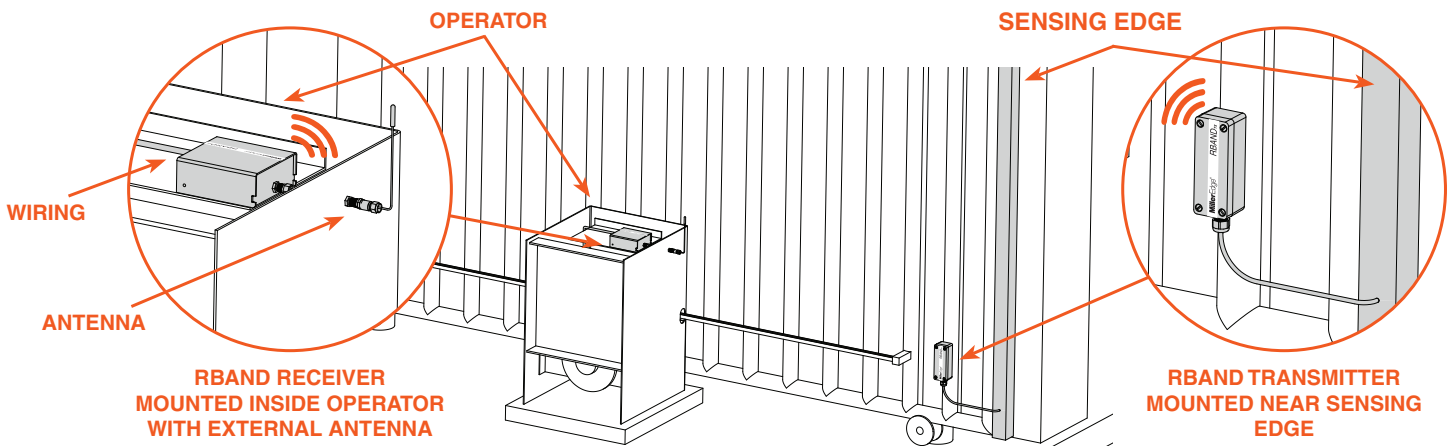

IMAGE 1. RBAND INSTALLATION WITH GATE EDGE

RB-G-K10\_Install\_20180712

5. Determine which monitored interface your operator uses:
  - 10K Operator [Table 1]: Connect the **COM (C1/C2)** and the correct output connections (**BS1/BS2**) to your operator. Set **DIP switch 4** to **off**.
  - N.C. Operator [Table 2]: Connect the **COM (C1/C2)** and the correct output connections (**CS1/CS2**) to your operator. The **A Test** terminals must be used for operators requiring N.C. inputs. Set **DIP switch 4** to **on**.
6. Turn on power to the operator. Note: it takes ~5 seconds for the Receiver to initialize.

**TABLE 1. REMOVABLE CONNECTORS**

	<p><b>8-PIN CONNECTOR</b></p> <p><b>Power</b></p> <ul style="list-style-type: none"> <li><b>+12/24 AC/DC</b> ▶ Constant power source</li> <li><b>-12/24 AC/DC</b> ▶ Constant power source (ground)</li> </ul> <p><b>Relay Output 1</b></p> <ul style="list-style-type: none"> <li><b>CS1</b> ▶ N.C. monitored input</li> <li><b>C1</b> ▶ Monitored input Common</li> <li><b>BS1</b> ▶ 10K monitored input</li> </ul> <p><b>Relay Output 2</b></p> <ul style="list-style-type: none"> <li><b>CS2</b> ▶ N.C. monitored input</li> <li><b>C2</b> ▶ Monitored input Common</li> <li><b>BS2</b> ▶ 10K monitored input</li> </ul> <p><b>4-PIN CONNECTOR</b></p> <p><b>Relay Output 3</b></p> <ul style="list-style-type: none"> <li><b>NO3</b> ▶ Low battery alarm (optional)</li> <li><b>C3</b> ▶ Low battery alarm (optional)</li> </ul> <p><b>N.C. Power Cycling</b></p> <ul style="list-style-type: none"> <li><b>COM</b> ▶ COM: Switched power Common</li> <li><b>A TEST</b> ▶ +12/24VDC: Switched power source</li> </ul>
--	---

**TABLE 2. NORMALLY CLOSED OPERATORS: Removable Connector Assignments by Manufacturer**

<p><b>HySecurity</b></p> <p style="text-align: right;"><b>DIP Switch #4</b> • On to run • Off to test</p>	<p><b>NOTE</b></p> <p>For operator software at these versions or higher, leave <b>DIP switch 4</b> in the <b>on</b> position:</p> <ul style="list-style-type: none"> <li>• Smart Touch Controllers (STC): h4.56</li> <li>• Smart DC Controllers (SDC): h5.57</li> <li>• S.T.A.R.T.: v3.03</li> </ul>
<p><b>Ramset</b></p> <p style="text-align: right;"><b>DIP Switch #4</b> • Turn to on</p>	
<p><b>All-O-Matic</b></p> <p style="text-align: right;"><b>DIP Switch #4</b> • Turn to on</p>	<p><b>Maximum Controls</b></p> <p style="text-align: right;"><b>DIP Switch #4</b> • Turn to on</p>

**IMAGE 2. RBAND GATE EDGE RECEIVER PCB & CONNECTIONS**

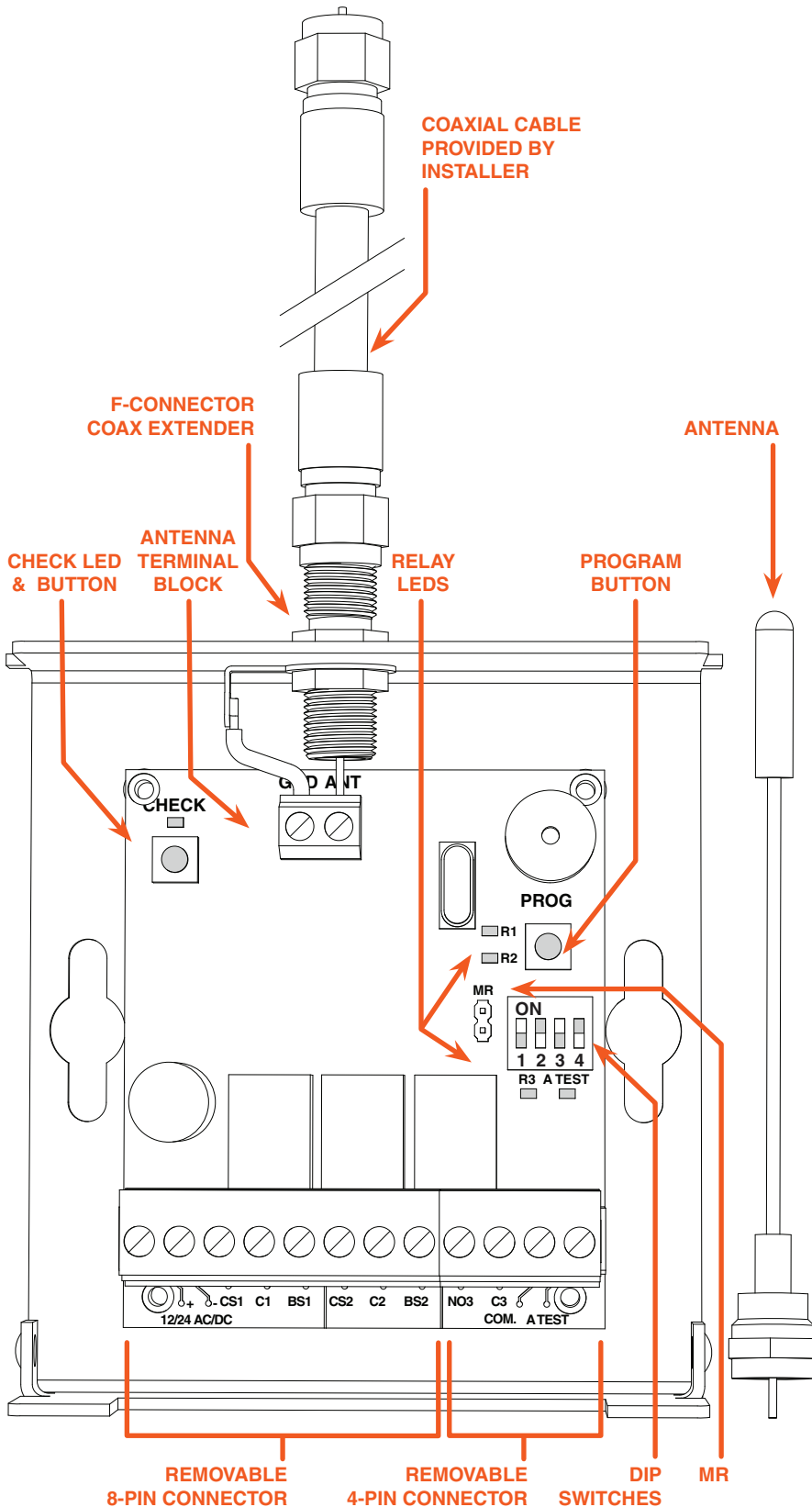

**LED INDICATORS**

**R1 & R2 RELAY LEDs**

- **On:** No transmitters programmed
- **Off:** Programmed
- **On (transmitters programmed):** Fault condition

**R3 RELAY LED**

- **On** when battery is low

**A TEST LED**

- **On** when in **test** mode

**CHECK LED**

(both channels programmed)

- Programmed: Check LED flashes every 5 seconds

**DIP SWITCH SETTINGS**

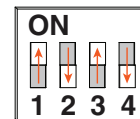

**Switch 1-3:** Leave switches in factory default settings

**Switch 4:** Used to enable Normally Closed cycle testing:

- 10K Operator: Set to **off**
- N.C. Operator: Set to **on** and connect the switched power to the **A Test** and **Common** pins shown above [TABLE 2]

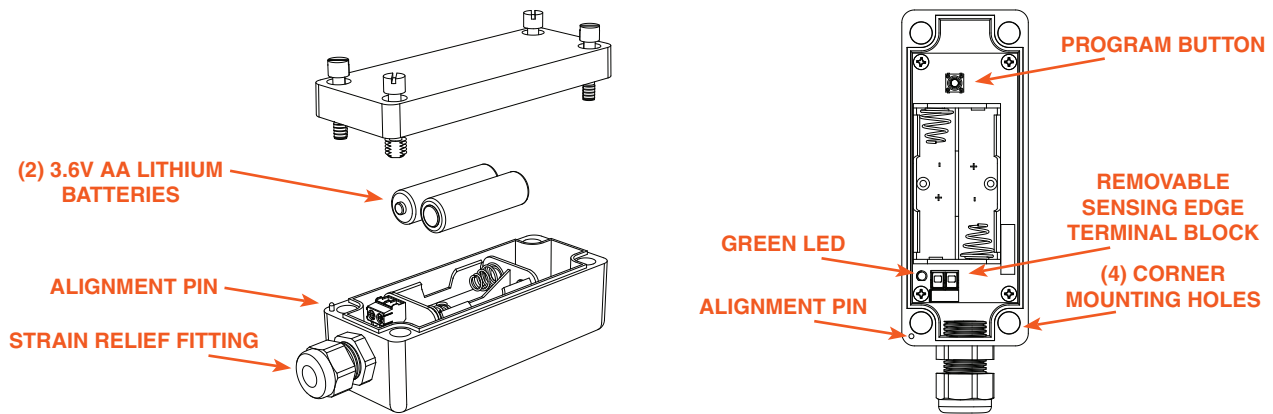

IMAGE 3. RBAND EDGE TRANSMITTER PCB & CONNECTIONS

### 3. PROGRAM MODE

For best performance, turn on all other wireless devices (e.g. card readers, etc.) prior to starting the programming process. The RBand Receiver will search for the quietest RF channel.

1. Confirm the Receiver is powered up. Prior to mounting the Transmitter, remove the cover and insert the batteries, noting their polarity. The **green LED** on the Transmitter may blink to indicate that it has not been associated with the Receiver yet [IMAGE 3].
2. To enter **learn** mode, press and hold the Receiver **program button** until you hear a beep and only the **R1 LED** is on, then release the button [IMAGE 2].
3. Within 10 seconds, press the Transmitter **program button** for ~2 seconds [IMAGE 3]. The Receiver should **beep**. Wait 10 seconds for 2 additional **beeps** to indicate that programming is complete.
4. To program a Transmitter to Channel 2, press and hold the Receiver **program button** until the second **beep** and the **R2 LED** is on, then release the button. Repeat 3-3.
5. To associate up to 2 additional (3 total) transmitters per channel, repeat steps 3-1 to 3-4.
6. The **R1** and **R2 LEDs** will stay on until a 10K sensing edge is connected to the Transmitter(s) [SECTION 4].
7. Replace the cover on the Receiver.

### 4. TRANSMITTER: INSTALL & TEST

1. Strip back approximately 2 inches of outer covering of sensing edge cable, then feed through the Transmitter **strain relief fitting**. Connect the two sensing edge wires to the removable terminal. Dress the wires with a small service loop and tighten the strain relief. Mount unit utilizing the mounting holes at the 4 corners of the Transmitter box. Affix lid to the Transmitter, noting the **alignment pin** [IMAGE 3].
  - Note: Altering the NEMA 4 Transmitter enclosure (such as drilling) and/or removal of the PCB is not advised and will void the manufacturer warranty.
2. Test the sensing edge for functionality.

### 5. TROUBLESHOOTING

1. To verify proper Transmitter function, press the Transmitter **program button**. The LED will blink and then turn off. Test the sensing edge and note that the LED turns on.
2. If the Receiver beeps 4 times every 4 seconds, replace the transmitter batteries.
3. If the Receiver does not react to the Transmitter and shows intermittent faults (R1 or R2 on and off randomly), follow these steps to check the RF signal strength:
  - a) Press the check button on the Receiver for ~2 seconds [IMAGE 2]; 4 beeps will be heard. You will then hear a beep every 1.5 seconds during the **check** process. Wait about 30 seconds; if no other beeps occur, your system is functioning. 3 quick beeps indicate a communication error.
  - b) Press the sensing edge and observe the **check LED**; 3-5 flashes is ideal. Less than 3 flashes means there is a weak signal. Press the other edge to check the signal strength for that Transmitter.
  - c) Check the antenna position for the best line-of-sight alignment. Check the coax cable to the antenna.
  - d) To exit the **check** function, press the **check button** or the system will time out after 5 minutes. There will be a series of beeps heard upon exiting.

## 6. ERASING THE RBAND RECEIVER

If you encounter intermittent performance or you have any other programming issues, erase the RBand Receiver and reprogram the Transmitters. The Receiver will search for a clear RF channel.

1. To erase all Transmitters programmed into the Receiver, use a screwdriver to short the two pins marked **MR** next to the **DIP switches** [IMAGE 2].
2. While shorting the pins, press and hold the **program button**; you will hear a series of 10 beeps followed by a rapid chirping sound. Release the **program button** and the **MR** pin short when your hear the chirping
3. Wait ~10 seconds and you will hear 2 beeps. The Receiver is now ready to be reprogrammed.

## 7. SPECIFICATIONS & CONTROLS

### RBAND EDGE TRANSMITTER (RB-TX10)

**Transmitter Frequency:** 916 MHz, FSK modulation

**Mounting:** 4 corner screws (provided)

**Power Source:** Batteries: 2 AA, 3.6V lithium, 2 year life expectancy

**Dimensions:** 1.80"L x 4.78"W x 1.75"H

**Program Button:** Momentary push button is used to associate the Transmitter to the Receiver

**TX Indicator Lights:**

- Green LED: Normally off
- Press **program button** for status:
  1. Green LED **off**: Good edge
  2. Green LED **on**: Active or damaged edge

### RBAND GATE EDGE RECEIVER (RB-G-RX10)

**Power:** 12-24 VAC/DC nominal (11-30 V max); 100 mA max current draw.

Power may be supplied from the operator or alternatively from an external supply.

**Dimensions:** 4.12"L x 3.65"W x 1.65"H

**Cable Connections:** Screw clamp type terminal blocks for 18-26 AWG wire

**External Antenna:** Monopole antenna supplied (gain: 5dBi +/-2dB)

**Program Button:** Used to associate a Transmitter with the desired receiver channel

**Check Button:** Used to determine signal strength

**RX Indicator Lights:**

- Check LED:
  1. Blinks every ~5 seconds to indicate working properly if both channels are programmed
  2. After **check** button is pressed, blinks to indicate signal strength; 4 or 5 blinks is ideal
- R1 and R2 LEDs:
  1. **Off** when the associated edge is **learned** and has no faults
  2. **On** solid: No Transmitters **learned** or edge activated
  3. Blink rapidly: Edge termination fault (RB-RX10C version only)
- R3 LED: **On** when low battery relay is active
- A TEST LED: **On** when in **test** mode

**Connections:**

- Power (2): Positive and ground, or AC
- Relay Output 1:
  1. CS1: Normally Closed
  2. C1: Common
  3. BS1: 10K termination
- Relay Output 2:
  1. CS2: Normally Closed
  2. C2: Common
  3. BS2: 10K termination
- Relay Output 3 (2): Relay closes when low battery is detected
- A TEST (2): Connect to switched DC power (+ and Com) for N.C. monitoring

## 8. FCC COMPLIANCE

### RBAND EDGE TRANSMITTER

**Model:** RB-TX10, RB-TX10B, RB-TX10C

**FCC ID:** U5Z-RB-TX10, U5Z-RB-TX10B, U5Z-RB-TX10C

This device complies with Part 15 of the FCC rules. Operation is subject to the following two conditions:

1. This device may not cause harmful interference and
2. This device must accept any interference received, including interference that may cause undesired operation.

This device complies with FCC radiation exposure limits for an uncontrolled environment. This device shall be installed and operated with a minimum distance of 0.8" between users or bystanders and the device.

This equipment has been tested and found to comply with the limits for a Class B digital device, pursuant to Part 15 of the FCC Rules:

These limits are designed to provide reasonable protection against harmful interference in a residential installation. This equipment generates, uses and can radiate radio frequency energy and, if not installed and used in accordance with the instructions, may cause harmful interference to radio communications. However, there is no guarantee that interference will not occur in a particular installation. If this equipment does cause harmful interference to radio or television reception, which may be determined by turning the equipment off and on, the user is encouraged to try to correct the interference by one or more of the following measures:

1. Re-orient or relocate the receiver antenna
2. Increase the separation between the equipment and the receiver
3. Connect the equipment into an outlet on a circuit different from that to which the receiver is connected
4. Consult the dealer or an experienced radio/TV technician for help

Changes or modifications not expressly approved by the party responsible for compliance could void the user's authority to operate the equipment.

### RBAND GATE EDGE RECEIVER

**Model:** RB-G-RX10, RB-G-RX10C

**FCC ID:** U5Z-RB-G-RX10, U5Z-RB-G-RX10C

This device complies with Part 15 of the FCC rules. Operation is subject to the following two conditions:

1. This device may not cause harmful interference and
2. This device must accept any interference received, including interference that may cause undesired operation.

This device complies with FCC radiation exposure limits for an uncontrolled environment. This device shall be installed and operated with a minimum distance of 0.8" between users or bystanders and the device.