



RBAND

MONITORED DOOR EDGE TRANSMITTER/RECEIVER

INSTALLATION INSTRUCTIONS

In partnership with
jcm[®]tech

Model: RB-P-K10

FC c[®]RU[®]us

DOOR

IMPORTANT: READ AND UNDERSTAND ALL INSTRUCTIONS BEFORE BEGINNING INSTALLATION

The Miller Edge RBand Monitored Door Edge Transmitter/Receiver system is intended to provide a wireless connection between a monitored sensing edge and a motorized operator installed with a garage door or grille. RBand meets the 2016 UL 325 requirements for monitored devices and has been certified as a UL 325 Recognized Component. It is designed for use with operators that comply with 2016 UL 325 using a Miller Edge 10K Sensing Edge.

1. PARTS LIST

Kit Contents:

1. RBand Edge Transmitter (RB-TX10C)
2. RBand Door Edge Receiver (RB-P-RX10C)
3. (2) 3.6V AA lithium batteries*
4. (4) #6 pan head transmitter mounting screws

*Replacement 3.6V AA lithium batteries can be purchased at your local electronics store or via Miller Edge.

Required:

- 1/8" flat blade screwdriver
- 1/4" flat blade screwdriver
- Miller Edge 10K (T2/blue band) Sensing Edge

Recommended:

- Multi-meter capable of reading 10K Ω
- Mounting screws as required for receiver

2. RECEIVER INSTALLATION

- 2-1. Turn off power to the door operator.
- 2-2. Remove Receiver cover and mount the receiver base near the operator, where it will be in line of sight with the transmitter for the entire range of travel [IMAGE 1].
- 2-3. Connect power (12-24 VAC/DC) to the terminals marked **power**, noting the +/- polarity. 24 VAC power can be connected either way not polarity sensitive [IMAGE 2].
- 2-4. Connect both **OSE1_2FA** and **OSE1_2FB** to the photo-eye inputs on the operator. **OSE1_3F** is not used.
- 2-5. Replace the Receiver cover and turn on power to the operator. Note: it takes ~5 seconds for the Receiver to initialize.

Note: RBand 10K Door Edge Receiver is compatible with up to 3 RBand Transmitters.

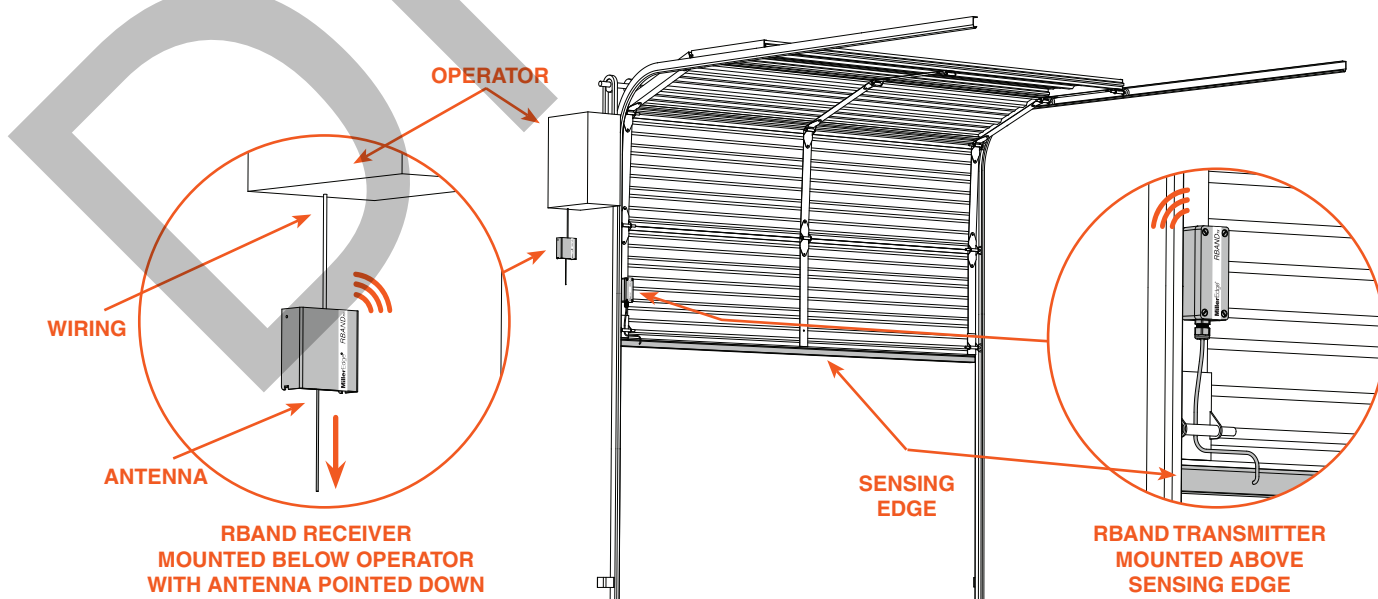

IMAGE 1. Door Installation with RBand Transmitter & Receiver

RB-P-K10_Install_20200115

LED INDICATORS

Initial Power

- No Transmitters Programmed: R1 LED on

R1 LED (1 edge connected)

- Programmed: **Off**
- Fault Condition: **On**

Check LED

- Programmed: Check LED flashes every 5 seconds

R2 LED

- Not used

DIP SWITCH SETTINGS

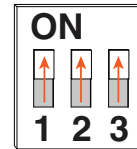

Leave switches in factory default settings (all on).

7-PIN CONNECTOR

- +12/24 VAC/DC** ▶ Constant power source
- 12/24 VAC/DC** ▶ Constant power source ground
- OSE1_3F** ▶ Not used
- OSE1_2FA** ▶ P.E. input terminal
- OSE1_2FB** ▶ P.E. input terminal or common
- NC2** ▶ Normally closed
- COM2** ▶ Open relay

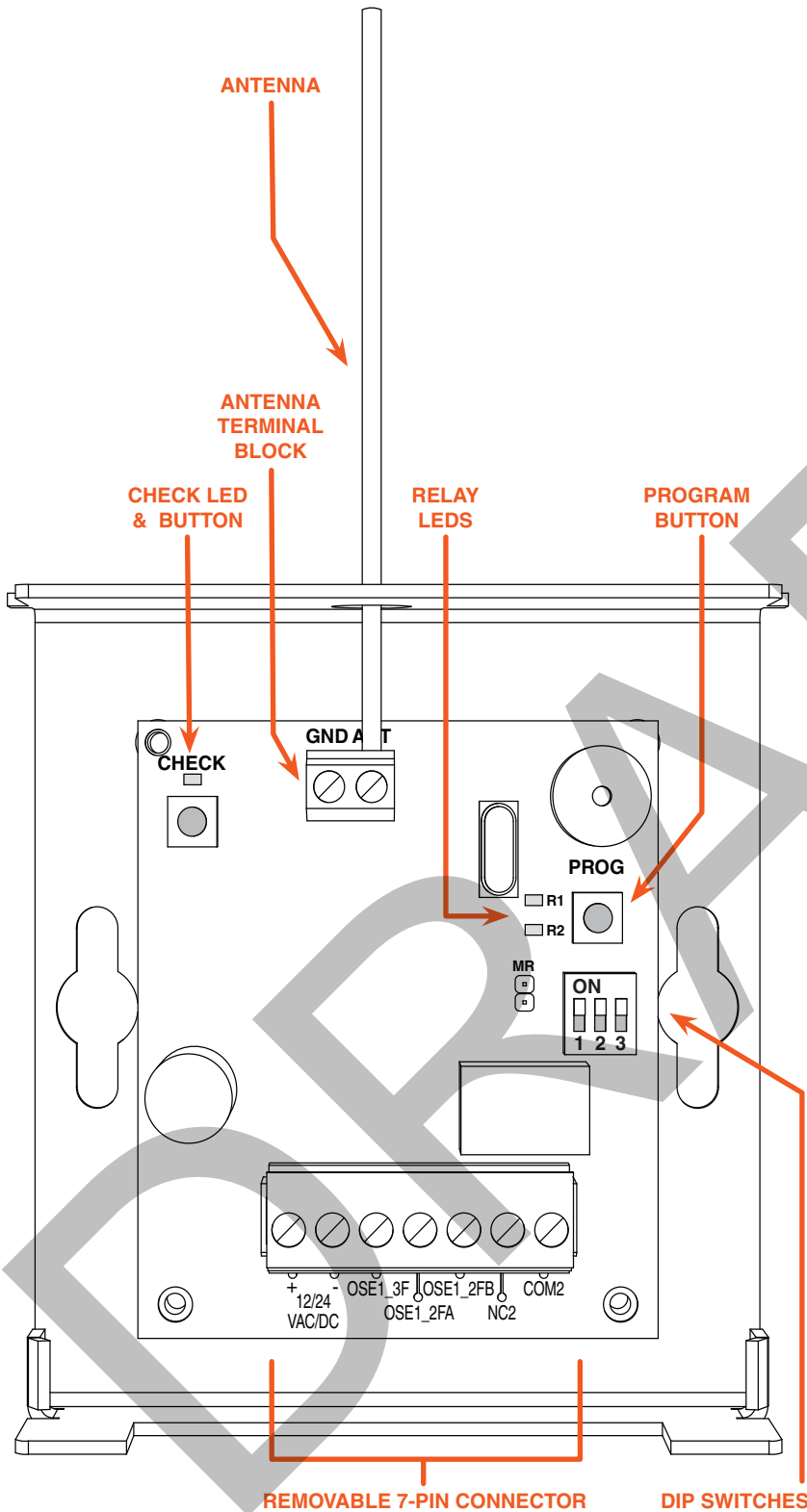

IMAGE 2. RBAND Door Edge Receiver PCB & Connections

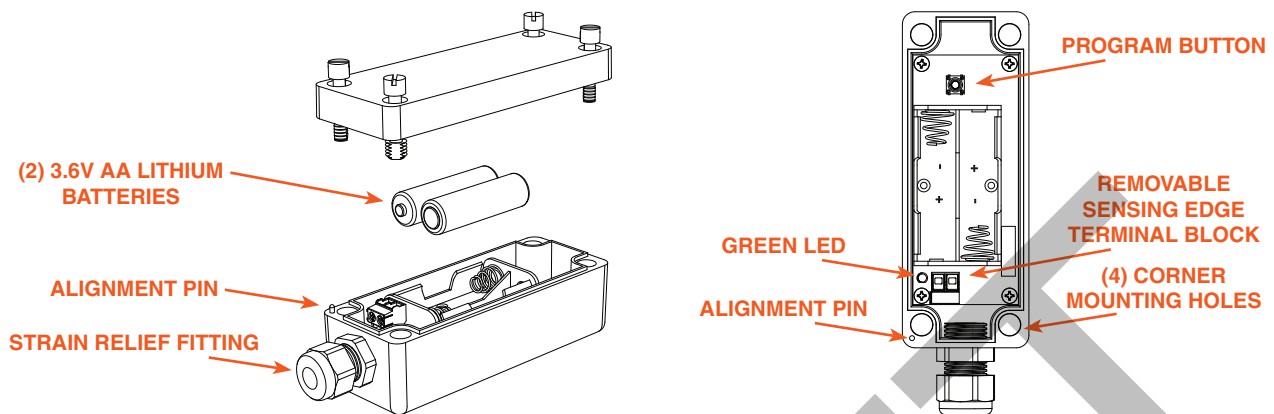

IMAGE 3. RBAND Edge Transmitter PCB & Connections

3. TRANSMITTER: PROGRAM MODE

- 3-1. Confirm the Receiver is powered up. Prior to mounting the Transmitter, remove the cover and insert the batteries, noting their polarity [IMAGE 3]. The **green LED** should blink to indicate that the Transmitter has not been associated with the Receiver yet.
- 3-2. To enter **learn** mode, press and hold the Receiver **program button** [IMAGE 2] for ~2 seconds until the **R1 LED** turns on, then release the button.
- 3-3. Press the Transmitter **program button** [IMAGE 3] for ~2 seconds. The Receiver should **beep**. Wait 10 seconds for an additional **beep** to indicate that programming is complete.
- 3-4. Repeat 3-2 and 3-3 for up to 3 Transmitters.

4. TRANSMITTER: INSTALL & TEST

- 4-1. Strip back approximately 2 inches of outer covering of sensing edge cable, then feed through the Transmitter **strain relief fitting** [IMAGE 3]. Connect the two sensing edge wires to the removable terminal. Dress the wires with a small service loop and tighten the strain relief. Mount unit utilizing the mounting holes at the 4 corners of the Transmitter box. Return lid to Transmitter, noting the **alignment pin** [IMAGE 3].
- 4-2. Test the sensing edge for functionality: press the sensing edge and the Receiver **R1 LED** will turn on.

5. TROUBLESHOOTING

If the Receiver does not react to the Transmitter, you can check the RF signal strength:

- 5-1. Press the **check button** on the Receiver for ~2 seconds [IMAGE 2]; 4 beeps will be heard. You then will hear a beep every 1-1/2 seconds during the **check** process. Wait about 30 seconds; if no other beeps occur, your system is functioning. 3 quick beeps indicates a communication error.
- 5-2. Activate the sensing edge and observe the **check LED**; 3-5 flashes is ideal. Less than 3 flashes means there is a weak signal.
- 5-3. To exit **check** function, press the **check button** again, or the system will time-out after 5 minutes. There will be a series of beeps heard upon exiting.

6. ERASING THE RECEIVER

Erase the Receiver if you need to replace a Transmitter or you have any other programming problems:

- 6-1. Use a screwdriver to short the two pins next to the **DIP switch** marked **MR** [IMAGE 2].
- 6-2. While shorting the pins, press and hold the **program button** for several seconds; you will hear a series of 10 beeps following by a rapid chirping sound.
- 6-3. When the chirping stops, release the **program button**. Wait ~10 seconds and you will hear 2 beeps. The Receiver is now ready to be reprogrammed.

7. TRANSMITTER: SPECIFICATIONS & CONTROLS

Transmitter Frequency: 916 MHz, FSK modulation

TX Indicator Lights:

- Green LED: Normally off
- Press program button for status

Mounting: 4 corner screws (provided)

Power Source: Batteries: 2 AA, 3.6V lithium, 2 year life expectancy

Dimensions: 1.80"L x 4.78"W x 1.75"H

Program Button: Momentary push button is used to associate the Transmitter to the Receiver.

8. RECEIVER: SPECIFICATIONS & CONTROLS

Power: 12-24 VAC/DC nominal (11-30 V max); power may be supplied from the operator or alternatively from an external supply. 100 mA maximum current draw.

Cable Connections: Screw clamp type terminal blocks for 18-26 AWG wire.

Dimensions: 4.12"L x 3.65"W x 1.65"H

Learn Button: Used to associate a Transmitter with the desired receiver channel.

Check Button: Press to determine the signal strength. 4 or 5 blinks is ideal.

RX Indicator Lights:

- Check LED:
 1. Blinks every ~5 seconds to indicate working properly
- Channel LED:
 1. Off when the associated sensing edge is **learned** and has no faults
 2. On solid: No Transmitters **learned** or sensing edge is active

Connections:

- Power (2)
- Output:
 1. OSE1_2F: Photo-eye output
 2. OSE1_3F: High speed pulse output (not commonly used)
 3. NC2: Normally Open output for non-monitored applications

9. FCC COMPLIANCE

Transmitter

Model: RB-TX10C

FCC ID: U5Z-RB-TX10C

Receiver

Model: RB-P-RX10C

FCC ID: U5Z-RB-P-RX10C

This device complies with Part 15 of the FCC rules. Operation is subject to the following two conditions:

1. This device may not cause harmful interference and
2. This device must accept any interference received, including interference that may cause undesired operation.

This equipment has been tested and found to comply with the limits for a Class B digital device, pursuant to Part 15 of the FCC Rules:

These limits are designed to provide reasonable protection against harmful interference in a residential installation. This equipment generates, uses and can radiate radio frequency energy and, if not installed and used in accordance with the instructions, may cause harmful interference to radio communications. However, there is no guarantee that interference will not occur in a particular installation. If this equipment does cause harmful interference to radio or television reception, which may be determined by turning the equipment off and on, the user is encouraged to try to correct the interference by one or more of the following measures:

1. Re-orient or relocate the receiver antenna
2. Increase the separation between the equipment and the receiver
3. Connect the equipment into an outlet on a circuit different from that to which the receiver is connected
4. Consult the dealer or an experienced radio/TV technician for help

Changes or modifications not expressly approved by the party responsible for compliance could void the user's authority to operate the equipment.

This device complies with the FCC RF exposure limits and has been evaluated in compliance with mobile exposure conditions. The equipment must be installed and operated with minimum distance of 20 cm of the human body.