



SPORTON International Inc.

No. 52, Hwa Ya 1st Rd., Hwa Ya Technology Park, Kwei-Shan Hsiang, Tao Yuan Hsien, Taiwan, R.O.C.
Ph: 886-3-327-3456 / FAX: 886-3-327-0973 / www.sporton.com.tw

FCC RADIO TEST REPORT

Applicant's company	Hitron Technologies
Applicant Address	No.1-8, Lising 1st Rd. Hsinchu Science Park, Hsinchu 300, Taiwan
FCC ID	U4P-HTGDS1
Manufacturer's company	Hitron Technologies
Manufacturer Address	No.1-8, Lising 1st Rd. Hsinchu Science Park, Hsinchu 300, Taiwan

Product Name	Garage Door Sensor
Brand Name	hitron
Model No.	HT-GDS1
Test Rule	47 CFR FCC Part 15 Subpart C § 15.247
Test Freq. Range	2400~2483.5 MHz
Received Date	Jan. 27, 2015
Final Test Date	Mar. 11, 2015
Submission Type	Original Equipment

Statement

Test result included is only for the IEEE 802.15.4 ZigBee of the product.

The test result in this report refers exclusively to the presented test model / sample.

Without written approval of SPORTON International Inc., the test report shall not be reproduced except in full.

The measurements and test results shown in this test report were made in accordance with the procedures and found in compliance with the limit given in **ANSI C63.10-2013, 47 CFR FCC Part 15 Subpart C** and **KDB 558074 D01 v03r02**.

The test equipment used to perform the test is calibrated and traceable to NML/ROC.



Table of Contents

1. VERIFICATION OF COMPLIANCE	1
2. SUMMARY OF THE TEST RESULT	2
3. GENERAL INFORMATION	3
3.1. Product Details.....	3
3.2. Accessories.....	3
3.3. Table for Filed Antenna.....	4
3.4. Table for Carrier Frequencies	5
3.5. Table for Test Modes	6
3.6. Table for Testing Locations.....	6
3.7. Table for Supporting Units	7
3.8. Table for Parameters of Test Software Setting	8
3.9. EUT Operation during Test	8
3.10. Duty Cycle.....	8
3.11. Test Configurations	9
4. TEST RESULT	11
4.1. Maximum Conducted Output Power Measurement.....	11
4.2. Power Spectral Density Measurement	13
4.3. 6dB Spectrum Bandwidth Measurement	17
4.4. Radiated Emissions Measurement	21
4.5. Emissions Measurement	31
4.6. Antenna Requirements	37
5. LIST OF MEASURING EQUIPMENTS	38
6. MEASUREMENT UNCERTAINTY	40
APPENDIX A. TEST PHOTOS	A1 ~ A4
APPENDIX B. MAXIMUM PERMISSIBLE EXPOSURE	B1 ~ B3



History of This Test Report

REPORT NO.	VERSION	DESCRIPTION	ISSUED DATE
FR512781	Rev. 01	Initial issue of report	Mar. 20, 2015



1. VERIFICATION OF COMPLIANCE

Product Name : Garage Door Sensor
Brand Name : hitron
Model No. : HT-GDS1
Applicant : Hitron Technologies
Test Rule Part(s) : 47 CFR FCC Part 15 Subpart C § 15.247

Sporton International as requested by the applicant to evaluate the EMC performance of the product sample received on Jan. 27, 2015 would like to declare that the tested sample has been evaluated and found to be in compliance with the tested rule parts. The data recorded as well as the test configuration specified is true and accurate for showing the sample's EMC nature.

A handwritten signature in blue ink that reads 'Sam Chen'. The signature is fluid and cursive, with a horizontal line drawn underneath the name.

Sam Chen

SPORTON INTERNATIONAL INC.

2. SUMMARY OF THE TEST RESULT

Applied Standard: 47 CFR FCC Part 15 Subpart C				
Part	Rule Section	Description of Test	Result	Under Limit
4.1	15.207	AC Power Line Conducted Emissions	-	Note 1
4.2	15.247(b)(3)	Maximum Conducted Output Power	Complies	22.61 dB
4.3	15.247(e)	Power Spectral Density	Complies	15.04 dB
4.4	15.247(a)(2)	6dB Spectrum Bandwidth	Complies	-
4.5	15.247(d)	Radiated Emissions	Complies	3.72 dB
4.6	15.247(d)	Band Edge Emissions	Complies	7.94 dB
4.7	15.203	Antenna Requirements	Complies	-

Note 1: It was supplied from battery for EUT; it's not necessary to apply to AC Power Port Conducted emission test.

3. GENERAL INFORMATION

3.1. Product Details

Items	Description
Power Type	From battery 3V*1
Modulation	DSSS (QPSK)
Data Rate (Mbps)	DSSS (250kbps)
Frequency Range	2400~2483.5 MHz
Channel Number	15
Channel Band Width (99%)	2.66 MHz
Maximum Conducted Output Power	7.39 dBm
Carrier Frequencies	Please refer to section 3.4
Antenna	Please refer to section 3.3

3.2. Accessories

N/A

3.3. Table for Filed Antenna

Ant.	Brand	P/N	Antenna Type	Connector	Gain (dBi)
1	PSA	RFANT321 61 20A3T	Chip Antenna	N/A	2.08

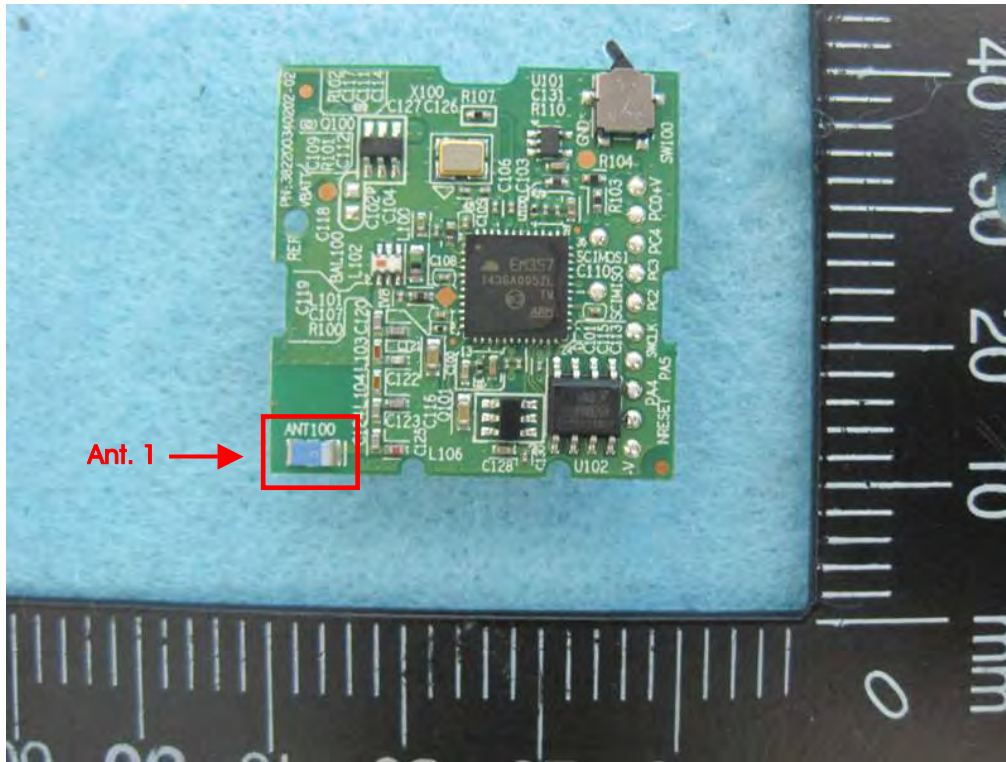

3.4. Table for Carrier Frequencies

Frequency Band	Channel No.	Frequency	Channel No.	Frequency
2400~2483.5 MHz	11	2405 MHz	19	2445 MHz
	12	2410 MHz	20	2450 MHz
	13	2415 MHz	21	2455 MHz
	14	2420 MHz	22	2460 MHz
	15	2425 MHz	23	2465 MHz
	16	2430 MHz	24	2470 MHz
	17	2435 MHz	25	2475 MHz
	18	2440 MHz	-	-

3.5. Table for Test Modes

Preliminary tests were performed in different data rate to find the worst radiated emission. The data rate shown in the table below is the worst-case rate with respect to the specific test item. Investigation has been done on all the possible configurations for searching the worst cases. The following table is a list of the test modes shown in this test report.

Test Items	Mode	Data Rate	Channel	Antenna
AC Power Line Conducted Emissions	Normal Link	-	-	-
Maximum Conducted Output Power	TX Mode	250 kbps	11/18/25	1
Power Spectral Density 6dB Spectrum Bandwidth	TX Mode	250 kbps	11/18/25	1
Radiated Emissions 9kHz~1GHz	Normal Link	-	-	-
Radiated Emissions 1GHz~10 th Harmonic	TX Mode	250 kbps	11/18/25	1
Band Edge Emissions	TX Mode	250 kbps	11/18/25	1

The following test modes were performed for all tests:

For Radiated Emission test<Below 1GHz>:

Mode 1. Place EUT in X axis

Mode 2. Place EUT in Y axis

Mode 3. Place EUT in Z axis

Mode 2 is the worst case, so it was selected to record in this test report

For Radiated Emission test<Above 1GHz>:

The EUT can be placed in X-axis, Y-axis and Z-axis. After evaluating, X-axis was the worst case, so it's recorded in this report.

3.6. Table for Testing Locations

Test Site Location				
Address:	No.8, Lane 724, Bo-ai St., Jhubei City, Hsinchu County 302, Taiwan, R.O.C.			
TEL:	886-3-656-9065			
FAX:	886-3-656-9085			
Test Site No.	Site Category	Location	FCC Reg. No.	IC File No.
03CH01-CB	SAC	Hsin Chu	262045	IC 4086D
CO01-CB	Conduction	Hsin Chu	262045	IC 4086D
TH01-CB	OVEN Room	Hsin Chu	-	-

Open Area Test Site (OATS); Semi Anechoic Chamber (SAC).

3.7. Table for Supporting Units

For Test Site No: 03CH01-CB <Below 1GHz>

Support Unit	Brand	Model	FCC ID
Wireless AP	D-Link	DIR-860L	RRK-2012070022
Notebook	DELL	M1330	E2K4965AGNM
Hub	Hitron teck	N/A	N/A

For Test Site No: 03CH01-CB <Above 1GHz>

Support Unit	Brand	Model	FCC ID
Notebook	DELL	M1330	E2K4965AGNM
Power Supply	Advanced	LPS-305	N/A

For Test Site No: TH01-CB

Support Unit	Brand	Model	FCC ID
Notebook	DELL	E6430	DoC
Power Supply	Advanced	LPS-305	N/A

3.8. Table for Parameters of Test Software Setting

During testing, Channel and Power Controlling Software provided by the customer was used to control the operating channel as well as the output power level. The RF output power selection is for the setting of RF output power expected by the customer and is going to be fixed on the firmware of the final end product.

Power Parameters of IEEE 802.15.4 ZigBee

Test Software Version	Teraterm-4.83		
Frequency	2405 MHz	2440 MHz	2475 MHz
IEEE 802.15.4 ZigBee	8	8	8

3.9. EUT Operation during Test

The EUT was programmed to be in continuously transmitting mode.

3.10. Duty Cycle

On Time (ms)	On+Off Time (ms)	Duty Cycle (%)	Duty Factor (dB)	1/T Minimum VBW (kHz)
1.000	1.000	1.000	100.00%	0.00

3.11. Test Configurations

3.11.1. Radiation Emissions Test Configuration

Test Configuration: 30MHz~1GHz

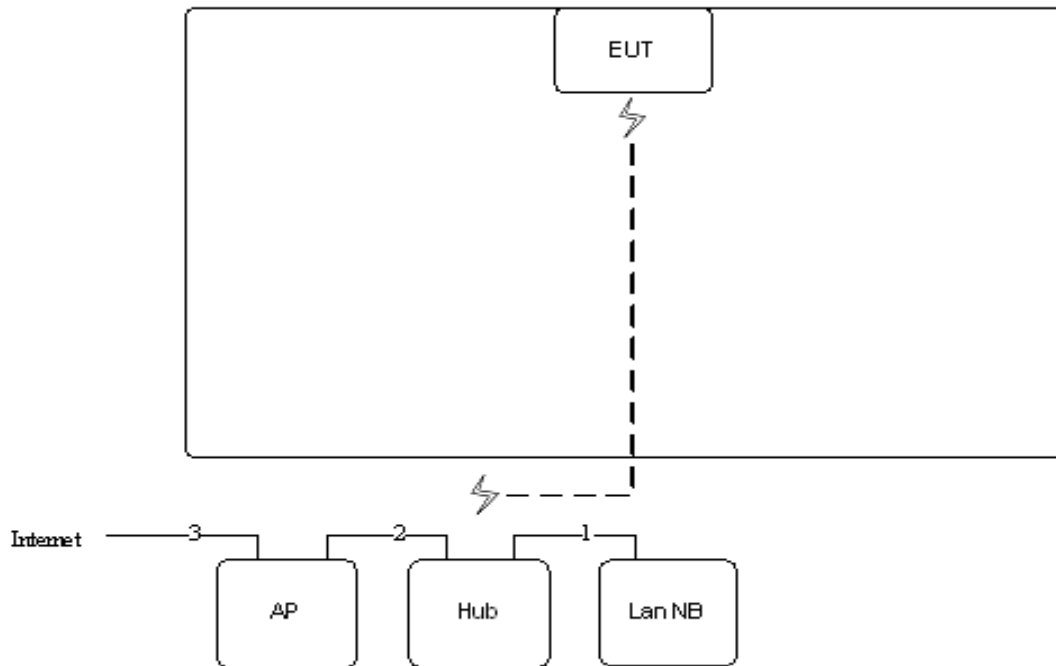

Item	Connection	Shielded	Length(m)
1	RJ-45 cable	No	1m
2	RJ-45 cable	No	1m
3	RJ-45 cable	No	50m

Test Configuration: Above 1GHz

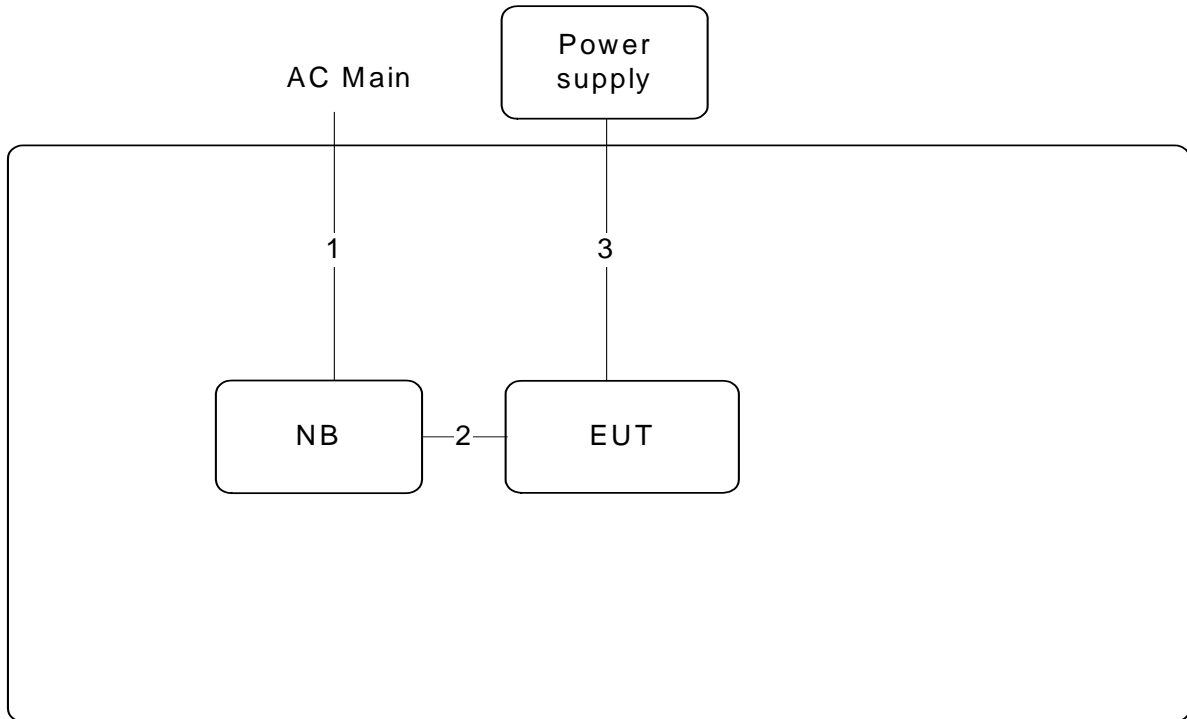

Item	Connection	Shielded	Length(m)
1	Power cable	No	1.5m
2	Console cable	No	1m
3	Power cable	No	1.5m

4. TEST RESULT

4.1. Maximum Conducted Output Power Measurement

4.1.1. Limit

For systems using digital modulation in the 2400-2483.5MHz, the limit for output power is 30dBm. The limited has to be reduced by the amount in dB that the gain of the antenna exceed 6dBi. In case of point-to-point operation, the limit has to be reduced by 1dB for every 3dB that the directional gain of the antenna exceeds 6dBi.

4.1.2. Measuring Instruments and Setting

Please refer to section 5 of equipments list in this report. The following table is the setting of the power meter.

Power Meter Parameter	Setting
Bandwidth	50MHz bandwidth is greater than the EUT emission bandwidth
Detector	Average

4.1.3. Test Procedures

1. Test procedures refer KDB 558074 D01 v03r02 section 9.2.3.2.
2. This procedure provides an alternative for determining the RMS output power using a broadband RF average power meter with a thermocouple detector.

4.1.4. Test Setup Layout

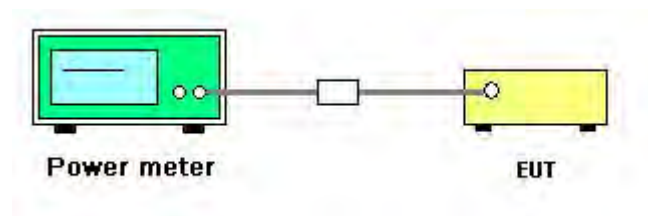

4.1.5. Test Deviation

There is no deviation with the original standard.

4.1.6. EUT Operation during Test

The EUT was programmed to be in continuously transmitting mode.

4.1.7. Test Result of Maximum Conducted Output Power

Temperature	20°C	Humidity	63%
Test Engineer	Sererwy Li	Configurations	802.15.4 Zigbee
Test Date	Mar. 09, 2015		

Configuration IEEE 802.15.4 Zigbee

Channel	Frequency	Conducted Power (dBm)	Max. Limit (dBm)	Result
11	2405 MHz	6.84	30.00	Complies
18	2440 MHz	7.15	30.00	Complies
25	2475 MHz	7.39	30.00	Complies

4.2. Power Spectral Density Measurement

4.2.1. Limit

For digitally modulated systems, the power spectral density conducted from the intentional radiator to the antenna shall not be greater than 8 dBm in any 3 kHz band during any time interval of continuous transmission.

4.2.2. Measuring Instruments and Setting

Please refer to section 5 of equipments list in this report. The following table is the setting of Spectrum Analyzer.

Spectrum Parameter	Setting
Attenuation	Auto
Span Frequency	5-30 % greater than the DTS channel bandwidth.
RBW	$3 \text{ kHz} \leq \text{RBW} \leq 100\text{kHz}$
VBW	$\geq 3 \times \text{RBW}$
Detector	Peak
Trace	Max Hold
Sweep Time	Auto couple

4.2.3. Test Procedures

1. Test was performed in accordance with KDB 558074 D01 v03r02 for Performing Compliance Measurements on Digital Transmission Systems (DTS) - section 10.2 Method PKPSD (peak PSD).
2. Use this procedure when the maximum conducted output power in the fundamental emission is used to demonstrate compliance. The EUT must be configured to transmit continuously at full power over the measurement duration.
3. Ensure that the number of measurement points in the sweep $\geq 2 \times \text{span}/\text{RBW}$ (use of a greater number of measurement points than this minimum requirement is recommended).
4. Use the peak marker function to determine the maximum level in any 3 kHz band segment within the fundamental EBW.
5. The resulting PSD level must be $\leq 8 \text{ dBm}$.

4.2.4. Test Setup Layout

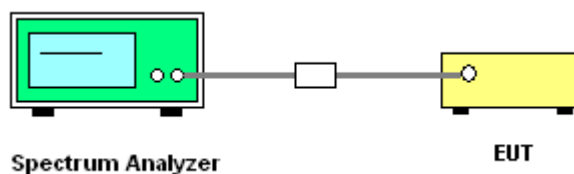

4.2.5. Test Deviation

There is no deviation with the original standard.

4.2.6. EUT Operation during Test

The EUT was programmed to be in continuously transmitting mode.

4.2.7. Test Result of Power Spectral Density

Temperature	20°C	Humidity	63%
Test Engineer	Sererwy Li	Configurations	802.15.4 Zigbee

Configuration IEEE 802.15.4 Zigbee

Frequency	Power Density (dBm/3kHz)	Power Density Limit (dBm/3kHz)	Result
2405 MHz	-7.76	8.00	Complies
2440 MHz	-7.62	8.00	Complies
2475 MHz	-7.04	8.00	Complies

Note: All the test values were listed in the report.

For plots, only the channel with worse result was shown.

Power Density Plot on Configuration 802.15.4 Zigbee / 2475 MHz

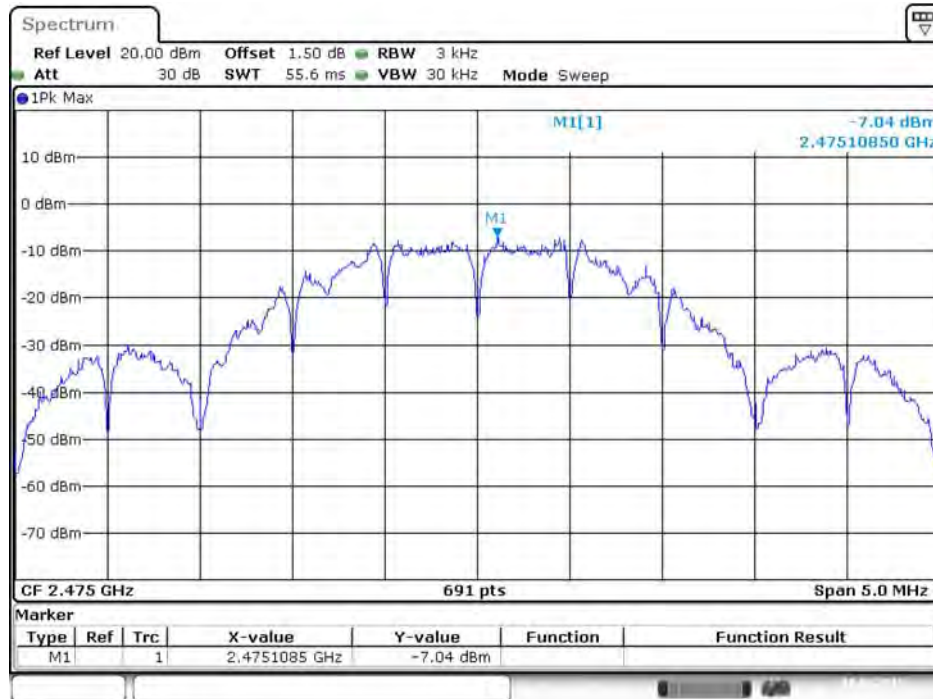

Date: 10.MAR.2015 17:17:43

4.3. 6dB Spectrum Bandwidth Measurement

4.3.1. Limit

For digital modulation systems, the minimum 6dB bandwidth shall be at least 500 kHz.

4.3.2. Measuring Instruments and Setting

Please refer to section 5 of equipments list in this report. The following table is the setting of the spectrum analyzer.

6dB Spectrum Bandwidth	
Spectrum Parameters	Setting
Attenuation	Auto
Span Frequency	> 6dB Bandwidth
RBW	100kHz
VBW	$\geq 3 \times \text{RBW}$
Detector	Peak
Trace	Max Hold
Sweep Time	Auto
99% Occupied Bandwidth	
Spectrum Parameters	Setting
Span	1.5 times to 5.0 times the OBW
RBW	1 % to 5 % of the OBW
VBW	$\geq 3 \times \text{RBW}$
Detector	Peak
Trace	Max Hold

4.3.3. Test Procedures

For Radiated 6dB Bandwidth Measurement:

1. The transmitter was radiated to the spectrum analyzer in peak hold mode.
2. Test was performed in accordance with KDB 558074 D01 v03r02 for Performing Compliance Measurements on Digital Transmission Systems (DTS) - section 8.0 DTS bandwidth = > 8.1 Option 1.
3. Measured the spectrum width with power higher than 6dB below carrier.

4.3.4. Test Setup Layout

For Radiated 6dB Bandwidth Measurement:

This test setup layout is the same as that shown in section 4.4.4.

4.3.5. Test Deviation

There is no deviation with the original standard.

4.3.6. EUT Operation during Test

The EUT was programmed to be in continuously transmitting mode.

4.3.7. Test Result of 6dB Spectrum Bandwidth

Temperature	20°C	Humidity	63%
Test Engineer	Sererwy Li	Configurations	802.15.4 Zigbee

Configuration 802.15.4 Zigbee

Channel	Frequency	6dB Bandwidth (MHz)	99% Occupied Bandwidth (MHz)	Min. Limit (kHz)	Test Result
11	2405 MHz	1.62	2.66	500.00	Complies
18	2440 MHz	1.60	2.63	500.00	Complies
25	2475 MHz	1.58	2.62	500.00	Complies

Note: All the test values were listed in the report.

For plots, only the channel with worse result was shown.

6 dB Bandwidth Plot on Configuration 802.15.4 Zigbee / 2475MHz

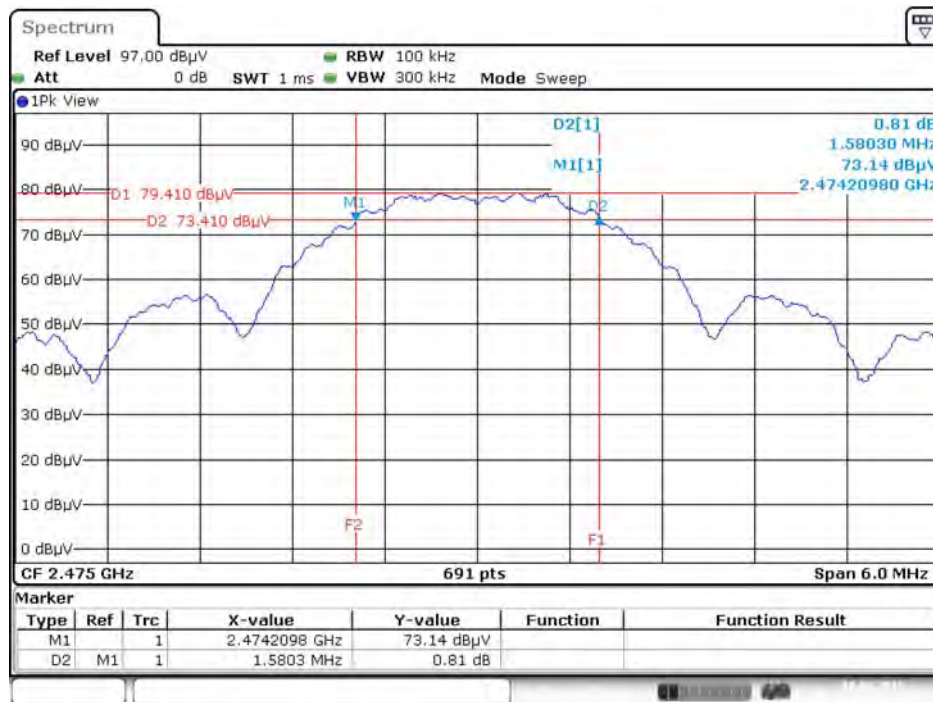

Date: 10.MAR.2015 17:10:32

99% Occupied Bandwidth Plot on Configuration 802.15.4 Zigbee / 2405 MHz



Date: 10.MAR.2015 16:59:08

4.4. Radiated Emissions Measurement

4.4.1. Limit

30dBc in any 100 kHz bandwidth outside the operating frequency band. In case the emission fall within the restricted band specified on 15.205(a), then the 15.209(a) limit in the table below has to be followed.

Frequencies (MHz)	Field Strength (micovolts/meter)	Measurement Distance (meters)
0.009~0.490	2400/F(kHz)	300
0.490~1.705	24000/F(kHz)	30
1.705~30.0	30	30
30~88	100	3
88~216	150	3
216~960	200	3
Above 960	500	3

4.4.2. Measuring Instruments and Setting

Please refer to section 5 of equipments list in this report. The following table is the setting of spectrum analyzer and receiver.

Spectrum Parameter	Setting
Attenuation	Auto
Start Frequency	1000 MHz
Stop Frequency	10th carrier harmonic
RBW / VBW (Emission in restricted band)	1 MHz / 3MHz for Peak, 1 MHz / 1/T for Average
RBW / VBW (Emission in non-restricted band)	100kHz / 300kHz for peak

Receiver Parameter	Setting
Attenuation	Auto
Start ~ Stop Frequency	9kHz~150kHz / RBW 200Hz for QP
Start ~ Stop Frequency	150kHz~30MHz / RBW 9kHz for QP
Start ~ Stop Frequency	30MHz~1000MHz / RBW 120kHz for QP

4.4.3. Test Procedures

1. Configure the EUT according to ANSI C63.10. The EUT was placed on the top of the turntable 1.5 meter above ground. The phase center of the receiving antenna mounted on the top of a height-variable antenna tower was placed 3 meters far away from the turntable.
2. Power on the EUT and all the supporting units. The turntable was rotated by 360 degrees to determine the position of the highest radiation.
3. The height of the broadband receiving antenna was varied between one meter and four meters above ground to find the maximum emissions field strength of both horizontal and vertical polarization.
4. For each suspected emissions, the antenna tower was scan (from 1 M to 4 M) and then the turntable was rotated (from 0 degree to 360 degrees) to find the maximum reading.
5. Set the test-receiver system to Peak or CISPR quasi-peak Detect Function with specified bandwidth under Maximum Hold Mode.
6. For emissions above 1GHz, use 1MHz VBW and 3MHz RBW for peak reading. Then 1MHz RBW and 1/T VBW for average reading in spectrum analyzer.
7. If the emissions level of the EUT in peak mode was 3 dB lower than the average limit specified, then testing will be stopped and peak values of EUT will be reported, otherwise, the emissions which do not have 3 dB margin will be repeated one by one using the quasi-peak method for below 1GHz.
8. For testing above 1GHz, the emissions level of the EUT in peak mode was lower than average limit (that means the emissions level in peak mode also complies with the limit in average mode), then testing will be stopped and peak values of EUT will be reported, otherwise, the emissions will be measured in average mode again and reported.
9. In case the emission is lower than 30MHz, loop antenna has to be used for measurement and the recorded data should be QP measured by receiver. High – Low scan is not required in this case.

4.4.4. Test Setup Layout

For Radiated Emissions: 9kHz ~30MHz

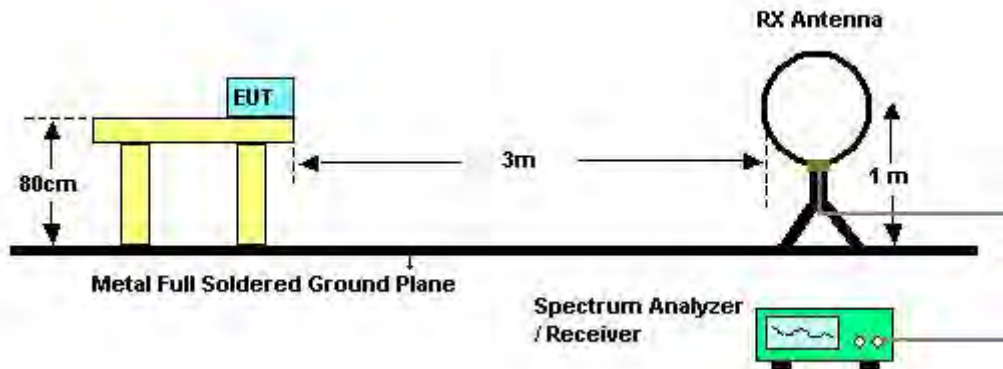

For Radiated Emissions: 30MHz~1GHz

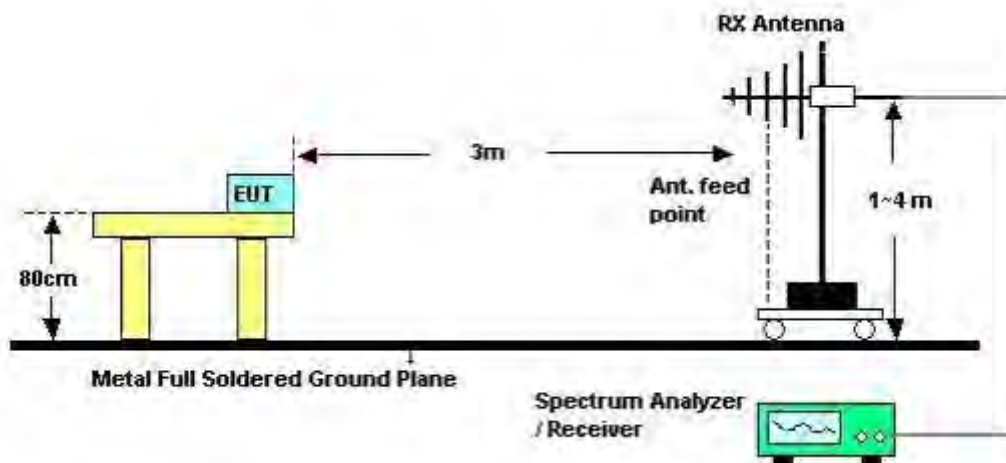

For Radiated Emissions: Above 1GHz

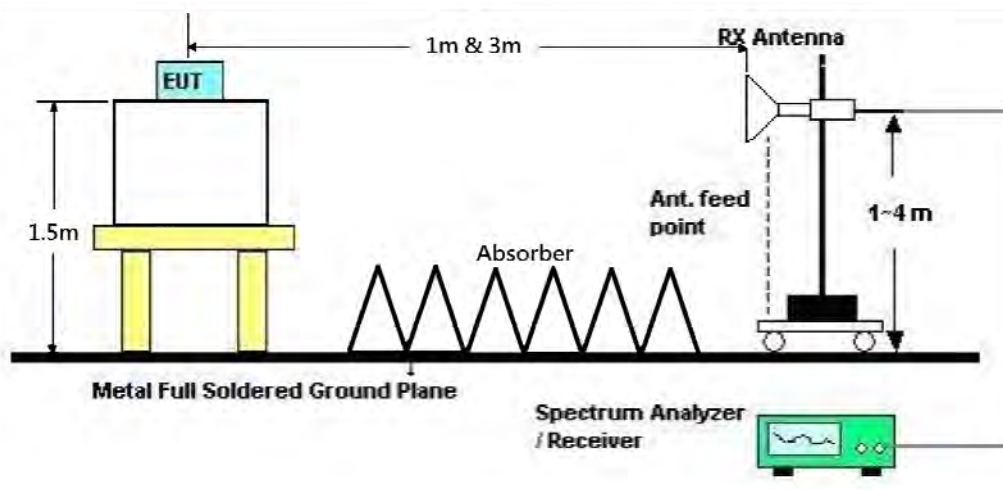

4.4.5. Test Deviation

There is no deviation with the original standard.

4.4.6. EUT Operation during Test

The EUT was programmed to be in continuously transmitting mode.

4.4.7. Results of Radiated Emissions (9kHz~30MHz)

Temperature	25°C	Humidity	40%
Test Engineer	Peter Wu	Configurations	Normal Link
Test Date	Feb. 07, 2015	Test Mode	Mode 2

Freq. (MHz)	Level (dBuV)	Over Limit (dB)	Limit Line (dBuV)	Remark
-	-	-	-	See Note

Note:

The amplitude of spurious emissions that are attenuated by more than 20 dB below the permissible value has no need to be reported.

Distance extrapolation factor = $40 \log(\text{specific distance} / \text{test distance})$ (dB);

Limit line = specific limits (dBuV) + distance extrapolation factor.

4.4.8. Results of Radiated Emissions (30MHz~1GHz)

Temperature	25°C	Humidity	40%
Test Engineer	Peter Wu	Configurations	Normal Link
Test Mode	Mode 2		

Horizontal

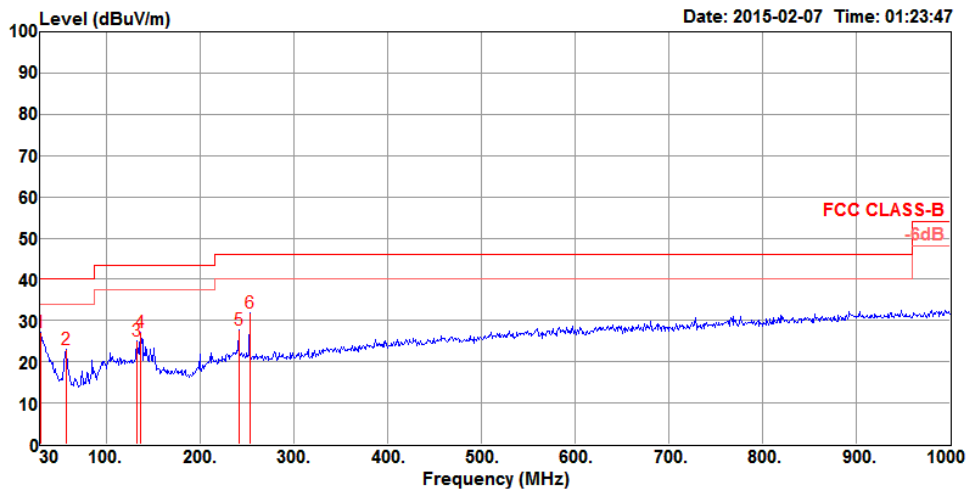

	Freq	Level	Limit Line	Over Limit	Read Level	CableAntenna Loss	Preamp Factor	A/Pos	T/Pos	Pol/Phase	Remark
	MHz	dBuV/m	dBuV/m	dB	dBuV	dB	dB/m	dB	cm	deg	
1	30.00	27.15	40.00	-12.85	38.86	0.43	20.10	32.24	125	301	HORIZONTAL Peak
2	58.13	22.93	40.00	-17.07	47.25	0.66	7.32	32.30	100	299	HORIZONTAL Peak
3	132.82	25.09	43.50	-18.41	43.78	1.00	12.52	32.21	125	191	HORIZONTAL Peak
4	136.70	27.26	43.50	-16.24	46.15	1.02	12.28	32.19	125	37	HORIZONTAL Peak
5	241.46	27.82	46.00	-18.18	46.29	1.36	12.33	32.16	150	32	HORIZONTAL Peak
6	253.10	31.97	46.00	-14.03	49.51	1.39	13.20	32.13	150	34	HORIZONTAL Peak

Vertical

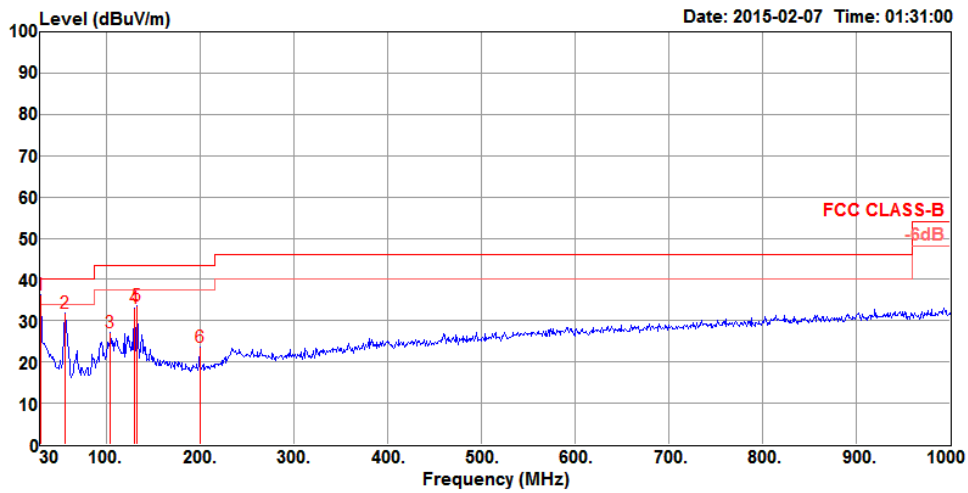

	Freq	Level	Limit	Over	Read	CableAntenna	Preamp	A/Pos	T/Pos	Pol/Phase	Remark
	MHz	dBuV/m	dBuV/m	dB	dBuV	dB	dB/m	dB	cm	deg	
1	30.00	36.28	40.00	-3.72	47.99	0.43	20.10	32.24	100	90	VERTICAL Peak
2	56.19	31.99	40.00	-8.01	55.98	0.65	7.66	32.30	100	359	VERTICAL Peak
3	104.69	27.29	43.50	-16.21	46.99	0.89	11.68	32.27	125	32	VERTICAL Peak
4	129.91	32.92	43.50	-10.58	51.45	0.99	12.70	32.22	125	230	VERTICAL Peak
5	132.82	33.61	43.50	-9.89	52.29	1.00	12.53	32.21	125	230	VERTICAL Peak
6	199.75	23.60	43.50	-19.90	44.05	1.23	10.38	32.06	125	239	VERTICAL Peak

Note:

The amplitude of spurious emissions that are attenuated by more than 20dB below the permissible value has no need to be reported.

Emission level (dBuV/m) = 20 log Emission level (uV/m).

Corrected Reading: Antenna Factor + Cable Loss + Read Level - Preamp Factor = Level.

4.4.9. Results for Radiated Emissions (1GHz~10th Harmonic)

Temperature	25°C	Humidity	40%
Test Engineer	Peter Wu	Configurations	802.15.4 Zigbee / CH 11
Test Date	Mar. 10, 2015		

Horizontal

	Freq	Level	Limit Line	Over Limit	Read Level	CableAntenna Loss	Antenna Factor	Preamp Factor	A/Pos	T/Pos	Remark	Pol/Phase
	MHz	dBuV/m	dBuV/m	dB	dBuV	dB	dB/m	dB	cm	deg		
1	4810.93	43.25	54.00	-10.75	38.92	6.40	31.06	33.13	100	264	Average	HORIZONTAL
2	4811.04	53.55	74.00	-20.45	49.22	6.40	31.06	33.13	100	264	Peak	HORIZONTAL
3	7213.39	44.91	54.00	-9.09	35.46	8.03	35.88	34.46	100	259	Average	HORIZONTAL
4	7216.31	56.48	74.00	-17.52	46.98	8.03	35.93	34.46	100	259	Peak	HORIZONTAL
5	12022.28	41.77	54.00	-12.23	28.02	10.73	38.98	35.96	100	303	Average	HORIZONTAL
6	12022.40	54.73	74.00	-19.27	40.98	10.73	38.98	35.96	100	303	Peak	HORIZONTAL

Vertical

	Freq	Level	Limit Line	Over Limit	Read Level	CableAntenna Loss	Antenna Factor	Preamp Factor	A/Pos	T/Pos	Remark	Pol/Phase
	MHz	dBuV/m	dBuV/m	dB	dBuV	dB	dB/m	dB	cm	deg		
1	4809.04	53.89	74.00	-20.11	49.55	6.40	31.07	33.13	155	251	Peak	VERTICAL
2	4810.98	44.22	54.00	-9.78	39.88	6.40	31.07	33.13	155	251	Average	VERTICAL
3	7213.39	45.25	54.00	-8.75	35.77	8.03	35.91	34.46	107	233	Average	VERTICAL
4	7216.62	57.20	74.00	-16.80	47.71	8.03	35.92	34.46	107	233	Peak	VERTICAL
5	12022.28	43.10	54.00	-10.90	29.35	10.73	38.98	35.96	108	231	Average	VERTICAL
6	12022.46	57.38	74.00	-16.62	43.63	10.73	38.98	35.96	108	231	Peak	VERTICAL

Temperature	25°C	Humidity	40%
Test Engineer	Peter Wu	Configurations	802.15.4 Zigbee / CH 18
Test Date	Mar. 10, 2015		

Horizontal

	Freq	Level	Limit Line	Over Limit	Read Level	Cable Loss	Antenna Factor	Preamp Factor	A/Pos	T/Pos	Remark	PoI/Phase
	MHz	dBuV/m	dBuV/m	dB	dBuV	dB	dB/m	dB	cm	deg		
1	4880.95	45.26	54.00	-8.74	40.72	6.44	31.18	33.08	100	268	Average	HORIZONTAL
2	4881.13	54.88	74.00	-19.12	50.34	6.44	31.18	33.08	100	268	Peak	HORIZONTAL
3	7321.40	43.93	54.00	-10.07	34.20	8.09	36.22	34.58	100	257	Average	HORIZONTAL
4	7321.72	55.55	74.00	-18.45	45.82	8.09	36.22	34.58	100	257	Peak	HORIZONTAL
5	12197.34	54.63	74.00	-19.37	40.83	10.77	38.79	35.76	100	98	Peak	HORIZONTAL
6	12202.56	41.31	54.00	-12.69	27.51	10.77	38.79	35.76	100	98	Average	HORIZONTAL

Vertical

	Freq	Level	Limit Line	Over Limit	Read Level	Cable Loss	Antenna Factor	Preamp Factor	A/Pos	T/Pos	Remark	PoI/Phase
	MHz	dBuV/m	dBuV/m	dB	dBuV	dB	dB/m	dB	cm	deg		
1	4880.98	45.80	54.00	-8.20	41.25	6.44	31.19	33.08	138	251	Average	VERTICAL
2	4880.98	55.39	74.00	-18.61	50.84	6.44	31.19	33.08	138	251	Peak	VERTICAL
3	7318.52	57.89	74.00	-16.11	48.18	8.09	36.20	34.58	100	263	Peak	VERTICAL
4	7321.52	46.42	54.00	-7.58	36.70	8.09	36.21	34.58	100	263	Average	VERTICAL
5	12197.40	56.91	74.00	-17.09	43.10	10.77	38.80	35.76	100	231	Peak	VERTICAL
6	12202.60	44.30	54.00	-9.70	30.50	10.77	38.79	35.76	100	231	Average	VERTICAL

Temperature	25°C	Humidity	40%
Test Engineer	Peter Wu	Configurations	802.15.4 Zigbee / CH 25
Test Date	Mar. 10, 2015		

Horizontal

	Freq	Level	Limit Line	Over Limit	Read Level	Cable Loss	Antenna Factor	Preamp Factor	A/Pos	T/Pos	Remark	Pol/Phase
	MHz	dBuV/m	dBuV/m	dB	dBuV	dB	dB/m	dB	cm	deg		
1	4948.99	57.52	74.00	-16.48	52.77	6.48	31.31	33.04	100	261	Peak	HORIZONTAL
2	4950.98	48.14	54.00	-5.86	43.38	6.49	31.31	33.04	100	261	Average	HORIZONTAL
3	7426.52	60.33	74.00	-13.67	50.36	8.15	36.51	34.69	100	39	Peak	HORIZONTAL
4	7426.58	49.11	54.00	-4.89	39.14	8.15	36.51	34.69	100	39	Average	HORIZONTAL
5	12372.26	43.67	54.00	-10.33	29.82	10.80	38.62	35.57	100	254	Average	HORIZONTAL
6	12377.56	54.83	74.00	-19.17	40.98	10.80	38.62	35.57	100	254	Peak	HORIZONTAL

Vertical

	Freq	Level	Limit Line	Over Limit	Read Level	Cable Loss	Antenna Factor	Preamp Factor	A/Pos	T/Pos	Remark	Pol/Phase
	MHz	dBuV/m	dBuV/m	dB	dBuV	dB	dB/m	dB	cm	deg		
1	4949.07	56.98	74.00	-17.02	52.23	6.48	31.31	33.04	156	251	Peak	VERTICAL
2	4950.98	47.62	54.00	-6.38	42.85	6.49	31.32	33.04	156	251	Average	VERTICAL
3	7426.46	52.07	54.00	-1.93	42.11	8.15	36.50	34.69	100	229	Average	VERTICAL
4	7426.54	62.71	74.00	-11.29	52.75	8.15	36.50	34.69	100	229	Peak	VERTICAL
5	12377.50	57.26	74.00	-16.74	43.41	10.80	38.62	35.57	100	225	Peak	VERTICAL
6	12377.58	45.12	54.00	-8.88	31.27	10.80	38.62	35.57	100	225	Average	VERTICAL

Note:

The amplitude of spurious emissions that are attenuated by more than 20dB below the permissible value has no need to be reported.

Emission level (dBuV/m) = 20 log Emission level (uV/m).

Corrected Reading: Antenna Factor + Cable Loss + Read Level - Preamp Factor = Level.

4.5. Emissions Measurement

4.5.1. Limit

30dBc in any 100 kHz bandwidth outside the operating frequency band. In case the emission fall within the restricted band specified on 15.205(a), then the 15.209(a) limit in the table below has to be followed.

Frequencies (MHz)	Field Strength (micovolts/meter)	Measurement Distance (meters)
0.009~0.490	2400/F(kHz)	300
0.490~1.705	24000/F(kHz)	30
1.705~30.0	30	30
30~88	100	3
88~216	150	3
216~960	200	3
Above 960	500	3

4.5.2. Measuring Instruments and Setting

Please refer to section 5 of equipments list in this report. The following table is the setting of the spectrum analyzer.

Spectrum Parameter	Setting
Attenuation	Auto
Span Frequency	100 MHz
RBW / VBW (Emission in restricted band)	1MHz / 3MHz for Peak, 1MHz / 1/T for Average
RBW / VBW (30dBc in any 100 kHz bandwidth emission)	100 kHz / 300 kHz for Peak

4.5.3. Test Procedures

For Radiated band edges Measurement:

- The test procedure is the same as section 4.4.3, only the frequency range investigated is limited to 100MHz around band edges.

For Radiated Out of Band Emission Measurement:

- Test was performed in accordance with KDB 558074 D01 v03r02 for Performing Compliance Measurements on Digital Transmission Systems (DTS) Operating Under §15.247 section 10.1 Unwanted Emissions into Non-Restricted Frequency Bands Measurement Procedure.

4.5.4. Test Setup Layout

For Radiated band edges Measurement:

This test setup layout is the same as that shown in section 4.4.4.

For Radiated Out of Band Emission Measurement:

This test setup layout is the same as that shown in section 4.4.4.

4.5.5. Test Deviation

There is no deviation with the original standard.

4.5.6. EUT Operation during Test

The EUT was programmed to be in continuously transmitting mode.

4.5.7. Test Result of Band Edge and Fundamental Emissions

Temperature	25°C	Humidity	40%
Test Engineer	Peter Wu	Configurations	802.15.4 Zigbee / CH 11, 18, 25
Test Date	Mar. 10, 2015		

Channel 11

	Freq	Level	Limit Line	Over Limit	Read Level	CableAntenna Loss	Antenna Factor	Preamp Factor	A/Pos	T/Pos	Remark	Pol/Phase
	MHz	dBuV/m	dBuV/m	dB	dBuV	dB	dB/m	dB	cm	deg		
1	2387.20	55.86	74.00	-18.14	24.32	4.43	27.11	0.00	114	68	Peak	HORIZONTAL
2	2390.00	44.58	54.00	-9.42	13.03	4.44	27.11	0.00	114	68	Average	HORIZONTAL
3 0	2404.60	100.60			68.99	4.45	27.16	0.00	114	68	Peak	HORIZONTAL
4 0	2405.00	96.03			64.42	4.45	27.16	0.00	114	68	Average	HORIZONTAL

Item 3, 4 are the fundamental frequency at 2405 MHz.

Channel 18

	Freq	Level	Limit Line	Over Limit	Read Level	CableAntenna Loss	Antenna Factor	Preamp Factor	A/Pos	T/Pos	Remark	Pol/Phase
	MHz	dBuV/m	dBuV/m	dB	dBuV	dB	dB/m	dB	cm	deg		
1	2369.20	56.02	74.00	-17.98	24.54	4.42	27.06	0.00	113	23	Peak	VERTICAL
2	2390.00	44.09	54.00	-9.91	12.53	4.44	27.12	0.00	113	23	Average	VERTICAL
3 0	2440.00	93.21			61.48	4.48	27.25	0.00	113	23	Average	VERTICAL
4 0	2440.40	97.85			66.12	4.48	27.25	0.00	113	23	Peak	VERTICAL
5	2488.70	44.41	54.00	-9.59	12.51	4.53	27.37	0.00	113	23	Average	VERTICAL
6	2493.10	57.42	74.00	-16.58	25.51	4.53	27.38	0.00	113	23	Peak	VERTICAL

Item 3, 4 are the fundamental frequency at 2440 MHz.

Channel 25

	Freq	Level	Limit Line	Over Limit	Read Level	CableAntenna Loss	Antenna Factor	Preamp Factor	A/Pos	T/Pos	Remark	Pol/Phase
	MHz	dBuV/m	dBuV/m	dB	dBuV	dB	dB/m	dB	cm	deg		
1 0	2474.60	99.45			67.59	4.51	27.35	0.00	100	18	Peak	HORIZONTAL
2 0	2475.00	94.69			62.83	4.51	27.35	0.00	100	18	Average	HORIZONTAL
3	2483.50	46.06	54.00	-7.94	14.19	4.52	27.35	0.00	100	18	Average	HORIZONTAL
4	2483.50	56.93	74.00	-17.07	25.06	4.52	27.35	0.00	100	18	Peak	HORIZONTAL

Item 1, 2 are the fundamental frequency at 2475 MHz.

For Emission not in Restricted Band
Plot on Configuration 802.15.4 Zigbee / Reference Level

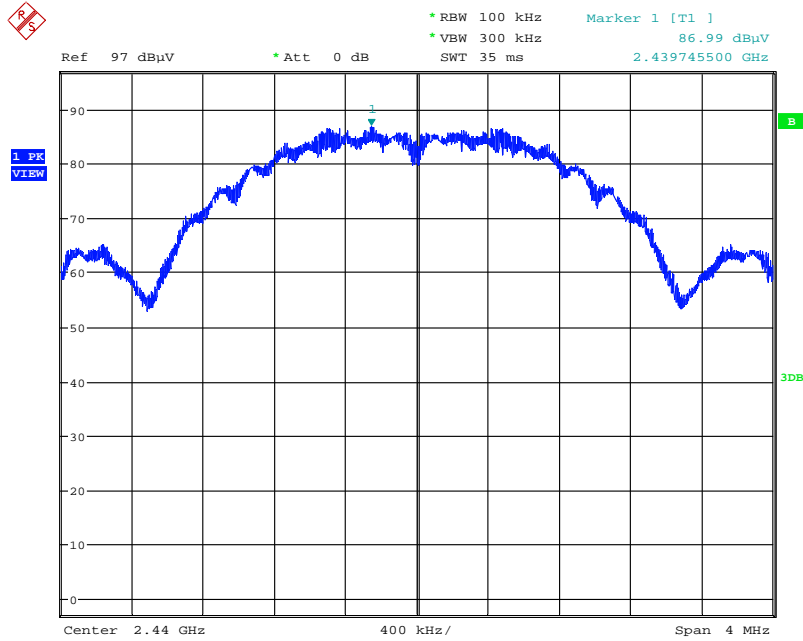

Date: 11.MAR.2015 01:36:58

Plot on Configuration 802.15.4 Zigbee / CH 11 / 30MHz~2400MHz (down 30dBc)

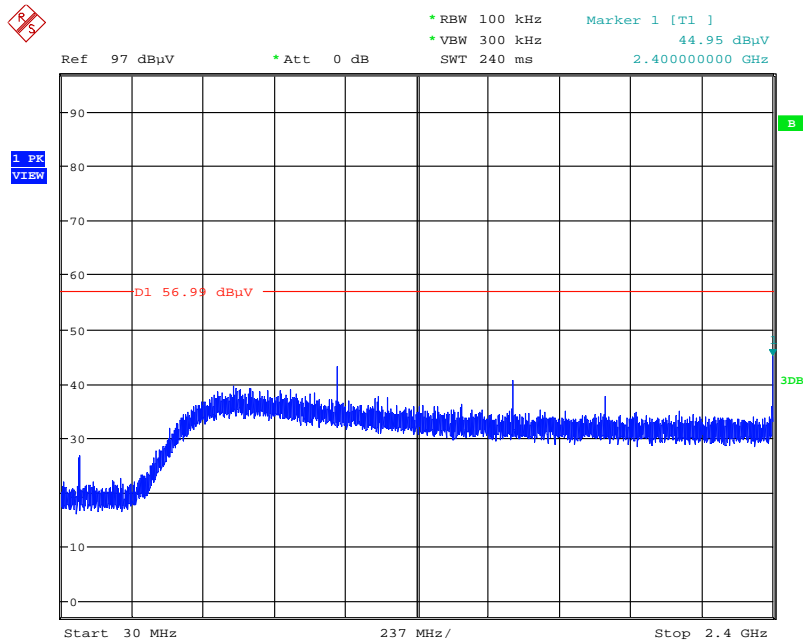

Date: 11.MAR.2015 01:41:06

Plot on Configuration 802.15.4 Zigbee / CH 11 / 2500MHz~26500MHz (down 30dBc)

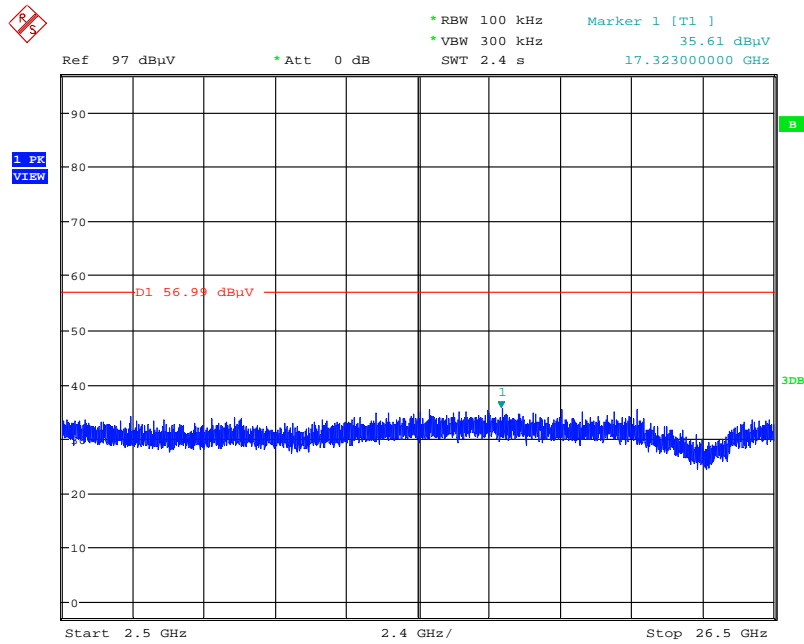

Date: 11.MAR.2015 01:48:42

Plot on Configuration 802.15.4 Zigbee / CH 25 / 30MHz~2400MHz (down 30dBc)

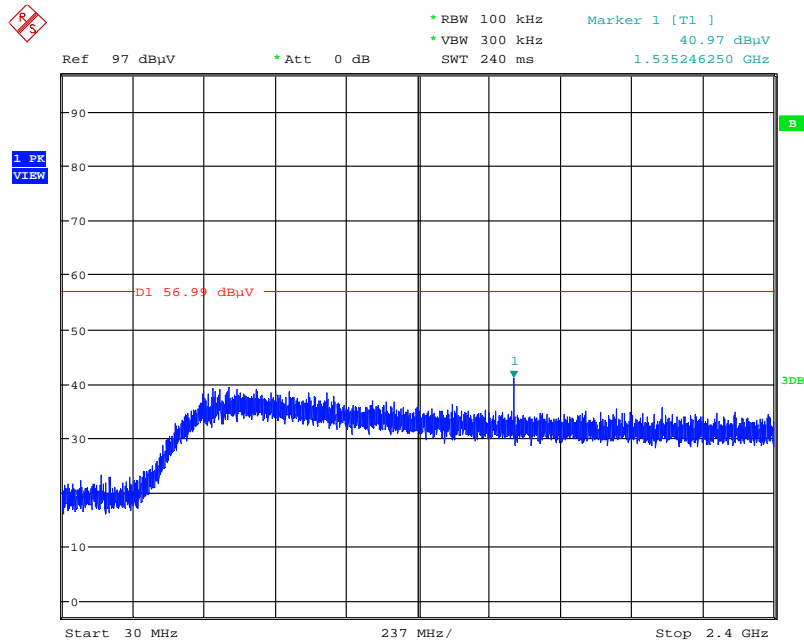

Date: 11.MAR.2015 01:52:05

4.6. Antenna Requirements

4.6.1. Limit

Except for special regulations, the Low-power Radio-frequency Devices must not be equipped with any jacket for installing an antenna with extension cable. An intentional radiator shall be designed to ensure that no antenna other than that furnished by the responsible party shall be used with the device. The use of a permanently attached antenna or of an antenna that uses a unique coupling to the intentional radiator shall be considered sufficient to comply with the provisions of this Section. The manufacturer may design the unit so that the user can replace a broken antenna, but the use of a standard antenna jack or electrical connector is prohibited. Further, this requirement does not apply to intentional radiators that must be professionally installed.

4.6.2. Antenna Connector Construction

Please refer to section 3.3 in this test report; antenna connector complied with the requirements.

5. LIST OF MEASURING EQUIPMENTS

Instrument	Manufacturer	Model No.	Serial No.	Characteristics	Calibration Date	Remark
BILOG ANTENNA	Schaffner	CBL6112D	22021	20MHz ~ 2GHz	May 26, 2014	Radiation (03CH01-CB)
Loop Antenna	Rohde & Schwarz	HFH2-Z2	100315	9 kHz~30 MHz	Jul. 28, 2014	Radiation (03CH01-CB)
Horn Antenna	EMCO	3115	00075790	750MHz~18GHz	Oct. 28, 2014	Radiation (03CH01-CB)
Horn Antenna	Schwarzbeck	BBHA 9170	BBHA9170252	15GHz ~ 40GHz	Aug. 22, 2014	Radiation (03CH01-CB)
Pre-Amplifier	Agilent	8447D	2944A10991	0.1MHz ~ 1.3GHz	Nov. 15, 2014	Radiation (03CH01-CB)
Pre-Amplifier	Agilent	8449B	3008A02310	1GHz ~ 26.5GHz	Jan. 12, 2015	Radiation (03CH01-CB)
Pre-Amplifier	WM	TF-130N-R1	923365	26GHz ~ 40GHz	Nov. 25, 2014	Radiation (03CH01-CB)
Spectrum Analyzer	R&S	FSV40	101026	9kHz ~ 40GHz	Aug. 28, 2014	Radiation (03CH01-CB)
EMI Test Receiver	R&S	ESR26	101289	9kHz~26GHz	Aug. 22, 2014	Radiation (03CH01-CB)
Turn Table	INN CO	CO 2000	N/A	0 ~ 360 degree	N.C.R.	Radiation (03CH01-CB)
Antenna Mast	INN CO	CO 2000	N/A	1 m - 4 m	N.C.R.	Radiation (03CH01-CB)
RF Cable-low	Woken	Low Cable-1	N/A	30 MHz - 1 GHz	Nov. 15, 2014	Radiation (03CH01-CB)
RF Cable-high	Woken	High Cable-1	N/A	1 GHz – 26.5 GHz	Nov. 15, 2014	Radiation (03CH01-CB)
RF Cable-high	Woken	High Cable-2	N/A	1 GHz – 26.5 GHz	Nov. 15, 2014	Radiation (03CH01-CB)
RF Cable-high	Woken	High Cable-3	N/A	1 GHz - 40 GHz	Nov. 15, 2014	Radiation (03CH01-CB)
RF Cable-high	Woken	High Cable-4	N/A	1 GHz - 40 GHz	Nov. 15, 2014	Radiation (03CH01-CB)
Signal analyzer	R&S	FSV40	100979	9kHz~40GHz	Dec.12, 2014	Conducted (TH01-CB)
RF Cable-high	Woken	High Cable-7	-	1 GHz – 26.5 GHz	Nov. 15, 2014	Conducted (TH01-CB)
RF Cable-high	Woken	High Cable-8	-	1 GHz – 26.5 GHz	Nov. 15, 2014	Conducted (TH01-CB)
RF Cable-high	Woken	High Cable-9	-	1 GHz – 26.5 GHz	Nov. 15, 2014	Conducted (TH01-CB)
RF Cable-high	Woken	High Cable-10	-	1 GHz – 26.5 GHz	Nov. 15, 2014	Conducted (TH01-CB)
RF Cable-high	Woken	High Cable-11	-	1 GHz – 26.5 GHz	Nov. 15, 2014	Conducted (TH01-CB)



Instrument	Manufacturer	Model No.	Serial No.	Characteristics	Callbration Date	Remark
Power Sensor	Anritsu	MA2411B	1126203	300MHz~40GHz	Oct. 06, 2014	Conducted (TH01-CB)
Power Meter	Anritsu	ML2495A	1210004	300MHz~40GHz	Oct. 06, 2014	Conducted (TH01-CB)

Note: Calibration Interval of instruments listed above is one year.

N.C.R. means Non-Calibration required.

6. MEASUREMENT UNCERTAINTY

Test Items	Uncertainty	Remark
Radiated Emission (30MHz ~ 1,000MHz)	3.6 dB	Confidence levels of 95%
Radiated Emission (1GHz ~ 18GHz)	3.7 dB	Confidence levels of 95%
Radiated Emission (18GHz ~ 40GHz)	3.5 dB	Confidence levels of 95%
Conducted Emission	1.7 dB	Confidence levels of 95%