



FCC TEST REPORT

REPORT NO.: RF121019E04A

MODEL NO.: CGNV, CGNVXXXXXXXX (where X may be any alphanumeric character or blank)

FCC ID: U4P-CGNV1A

RECEIVED: Oct. 19, 2012

TESTED: Nov. 10 to 13, 2012 and
Aug. 26 to 29, 2013

ISSUED: Sep. 04, 2013

APPLICANT: HitronTechnologies

ADDRESS: NO. 1-8, LISING 1ST RD., HSINCHU SCIENCE
PARK, HSINCHU, 300, TAIWAN.

ISSUED BY: Bureau Veritas Consumer Products Services
(H.K.) Ltd., Taoyuan Branch Hsin Chu Laboratory

LAB ADDRESS : No. 81-1, Lu Liao Keng, 9th Ling, Wu Lung Tsuen,
Chiung Lin Hsiang, Hsin Chu Hsien 307, Taiwan,
R.O.C.

TEST LOCATION (1): No. 81-1, Lu Liao Keng, 9th Ling, Wu Lung Tsuen,
Chiung Lin Hsiang, Hsin Chu Hsien 307, Taiwan,
R.O.C.

TEST LOCATION (2): No. 49, Ln. 206, Wende Rd., Shangshan Tsuen,
Chiung Lin Hsiang, Hsin Chu Hsien 307, Taiwan,
R.O.C.

This report should not be used by the client to claim product certification, approval, or endorsement by TAF or any government agencies.



This report is for your exclusive use. Any copying or replication of this report to or for any other person or entity, or use of our name or trademark, is permitted only with our prior written permission. This report sets forth our findings solely with respect to the test samples identified herein. The results set forth in this report are not indicative or representative of the quality or characteristics of the lot from which a test sample was taken or any similar or identical product unless specifically and expressly noted. Our report includes all of the tests requested by you and the results thereof based upon the information that you provided to us. You have 60 days from date of issuance of this report to notify us of any material error or omission caused by our negligence, provided, however, that such notice shall be in writing and shall specifically address the issue you wish to raise. A failure to raise such issue within the prescribed time shall constitute your unqualified acceptance of the completeness of this report, the tests conducted and the correctness of the report contents. Unless specific mention, the uncertainty of measurement has been explicitly taken into account to declare the compliance or non-compliance to the specification



A D T

Table of Contents

RELEASE CONTROL RECORD	4
1. CERTIFICATION	5
2. SUMMARY OF TEST RESULTS	6
2.1 MEASUREMENT UNCERTAINTY	7
3. GENERAL INFORMATION	8
3.1 GENERAL DESCRIPTION OF EUT	8
3.2 DESCRIPTION OF TEST MODES	10
3.2.1 TEST MODE APPLICABILITY AND TESTED CHANNEL DETAIL	11
3.3 GENERAL DESCRIPTION OF APPLIED STANDARDS	14
3.4 DESCRIPTION OF SUPPORT UNITS	15
3.5 CONFIGURATION OF SYSTEM UNDER TEST	16
4. TEST TYPES AND RESULTS	18
4.1 CONDUCTED EMISSION MEASUREMENT	18
4.1.1 LIMITS OF CONDUCTED EMISSION MEASUREMENT	18
4.1.2 TEST INSTRUMENTS	18
4.1.3 TEST PROCEDURES	19
4.1.4 DEVIATION FROM TEST STANDARD	19
4.1.5 TEST SETUP	19
4.1.6 EUT OPERATING CONDITIONS	20
4.1.7 TEST RESULTS	21
4.2 RADIATED EMISSION AND BANDEDGE MEASUREMENT	23
4.2.1 LIMITS OF RADIATED EMISSION AND BANDEDGE MEASUREMENT	23
4.2.2 TEST INSTRUMENTS	24
4.2.3 TEST PROCEDURES	26
4.2.4 DEVIATION FROM TEST STANDARD	26
4.2.5 TEST SETUP	27
4.2.6 EUT OPERATING CONDITIONS	27
4.2.7 TEST RESULTS	28
4.3 6dB BANDWIDTH MEASUREMENT	41
4.3.1 LIMITS OF 6dB BANDWIDTH MEASUREMENT	41
4.3.2 TEST INSTRUMENTS	41
4.3.3 TEST PROCEDURE	41
4.3.4 DEVIATION FROM TEST STANDARD	41
4.3.5 TEST SETUP	41
4.3.6 EUT OPERATING CONDITIONS	41
4.3.7 TEST RESULTS	42
4.4 CONDUCTED OUTPUT POWER MEASUREMENT	43
4.4.1 LIMITS OF CONDUCTED OUTPUT POWER MEASUREMENT	43
4.4.2 INSTRUMENTS	43
4.4.3 TEST PROCEDURES	43
4.4.4 DEVIATION FROM TEST STANDARD	43
4.4.5 TEST SETUP	44
4.4.6 EUT OPERATING CONDITIONS	44
4.4.7 TEST RESULTS	45
4.5 POWER SPECTRAL DENSITY MEASUREMENT	46
4.5.1 LIMITS OF POWER SPECTRAL DENSITY MEASUREMENT	46
4.5.2 TEST INSTRUMENTS	46
4.5.3 TEST PROCEDURE	46
4.5.4 DEVIATION FROM TEST STANDARD	46
4.5.5 TEST SETUP	46



A D T

4.5.6	EUT OPERATING CONDITION	46
4.5.7	TEST RESULTS	47
4.6	CONDUCTED OUT-BAND EMISSION MEASUREMENT	49
4.6.1	LIMITS OF CONDUCTED OUT-BAND EMISSION MEASUREMENT	49
4.6.2	TEST INSTRUMENTS	49
4.6.3	TEST PROCEDURE	49
4.6.4	DEVIATION FROM TEST STANDARD	50
4.6.5	TEST SETUP	50
4.6.6	EUT OPERATING CONDITION	50
4.6.7	TEST RESULTS	50
5.	PHOTOGRAPHS OF THE TEST CONFIGURATION	59
6.	INFORMATION ON THE TESTING LABORATORIES	60
7.	APPENDIX A - MODIFICATIONS RECORDERS FOR ENGINEERING CHANGES TO THE EUT BY THE LAB	61



RELEASE CONTROL RECORD

ISSUE NO.	REASON FOR CHANGE	DATE ISSUED
RF121019E04A	Original release	Sep. 04, 2013



1. CERTIFICATION

PRODUCT: Wireless Cable Gateway

BRAND NAME: hitron

MODEL NO.: CGNV, CGNVXXXXXXXX (where X may be any alphanumeric character or blank)

TEST SAMPLE: R&D SAMPLE

APPLICANT: HitronTechnologies

TESTED: Nov. 10 to 13, 2012 and Aug. 26 to 29, 2013

STANDARDS: **FCC Part 15, Subpart C (Section 15.247)**
ANSI C63.10-2009

The above equipment (Model: CGNV) has been tested by **Bureau Veritas Consumer Products Services (H.K.) Ltd., Taoyuan Branch**, and found compliance with the requirement of the above standards. The test record, data evaluation & Equipment Under Test (EUT) configurations represented herein are true and accurate accounts of the measurements of the sample's EMC characteristics under the conditions specified in this report.

PREPARED BY :  , **DATE:** Sep. 04, 2013
(Elsie Hsu, Specialist)

APPROVED BY :  , **DATE:** Sep. 04, 2013
(May Chen, Manager)



A D T

2. SUMMARY OF TEST RESULTS

The EUT has been tested according to the following specifications:

APPLIED STANDARD: FCC PART 15, SUBPART C (SECTION 15.247)			
STANDARD SECTION	TEST TYPE	RESULT	REMARK
15.207	AC Power Conducted Emission	PASS	Meet the requirement of limit. Minimum passing margin is -8.48dB at 0.41965MHz
15.247(d) 15.209	Radiated Emissions	PASS	Meet the requirement of limit. Minimum passing margin is -0.5dB at 4824.00MHz
15.247(d)	Band Edge Measurement	PASS	Meet the requirement of limit.
15.247(a)(2)	6dB bandwidth	PASS	Meet the requirement of limit.
15.247(b)	Conducted power	PASS	Meet the requirement of limit.
15.247(e)	Power Spectral Density	PASS	Meet the requirement of limit.
15.203	Antenna Requirement	PASS	No antenna connector is used.



A D T

2.1 MEASUREMENT UNCERTAINTY

Where relevant, the following measurement uncertainty levels have been estimated for tests performed on the EUT as specified in CISPR 16-4-2:

This uncertainty represents an expanded uncertainty expressed at approximately the 95% confidence level using a coverage factor of $k=2$.

Measurement	Value
Conducted emissions	2.98 dB
Radiated emissions (30MHz-1GHz)	5.63 dB
Radiated emissions (1GHz -6GHz)	3.84 dB
Radiated emissions (6GHz -18GHz)	4.09 dB
Radiated emissions (18GHz -40GHz)	4.24 dB



A D T

3. GENERAL INFORMATION

3.1 GENERAL DESCRIPTION OF EUT

PRODUCT	Wireless Cable Gateway
MODEL NO.	CGNV, CGNVXXXXXXXX (where X may be any alphanumeric character or blank)
POWER SUPPLY	DC 15V from internal power supply
MODULATION TYPE	CCK, DQPSK, DBPSK for DSSS 64QAM, 16QAM, QPSK, BPSK for OFDM
MODULATION TECHNOLOGY	DSSS, OFDM
TRANSFER RATE	802.11b: Up to 11Mbps 802.11g: Up to 54Mbps 802.11n (HT20): Up to 216.7Mbps 802.11n (HT40): Up to 450Mbps
OPERATING FREQUENCY	2.412 ~ 2.462GHz
NUMBER OF CHANNEL	11 for 802.11b, 802.11g, 802.11n (HT20) 7 for 802.11n (HT40)
MAXIMUM OUTPUT POWER	802.11b: 177.828mW 802.11g: 478.630mW 802.11n (HT20): 853.425mW 802.11n (HT40): 957.559mW
ANTENNA TYPE	Please see NOTE
DATA CABLE	NA
I/O PORTS	Refer to user's manual
ASSOCIATED DEVICES	Battery x 1 (option)

NOTE:

1. The EUT must be supplied with an internal power supply as following information:

Brand	Model No.	Spec.
AOEM	A036115-F81	AC I/P: 100~240V, 1A, 60Hz DC O/P: 15V, 2.4A

2. The EUT has two model names, which are identical to each other in all aspects except for the following table:

Model No.	Difference
CGNV	For marketing requirement
CGNVXXXXXXXX (where X may be any alphanumeric character or blank)	

From the above models, model: CGNV was selected as representative model for the test and its data was recorded in this report.

3. The EUT must be collocated with a battery as following table:

Brand	Model No.	Spec.
MITAC	BP-LC2200/31-A0002 S	DC O/P: 12.6V, 2.5A

4. The antennas provided to the EUT, please refer to the following table:

Transmitter Circuit	Brand	Model	Antenna Type	Gain (Net dBi)	Connector type	Frequency range (MHz to MHz)
Chain (0)	Airgain	M2445J-T2-100C	PCB	4.5	ipex	2400-2490
Chain (1)	Airgain	M2445J-T2-190C	PCB	4.5	ipex	2400-2490
Chain (2)	Airgain	N2420DS-T-G100C	PCB	3.1	ipex	2400-2490

5. The EUT incorporates a MIMO function.

MODULATION MODE	TX/RX FUNCTION
802.11b	1TX/1RX
802.11g	1TX/1RX
802.11n (HT20)	3TX/3RX
802.11n (HT40)	3TX/3RX

6. When the EUT operating in 802.11n, the software operation, which is defined by manufacturer, MCS (Modulation and Coding Schemes) from 0 to 23.

7. The above EUT information was declared by manufacturer and for more detailed features description, please refer to the manufacturer's specifications or user's manual.



A D T

3.2 DESCRIPTION OF TEST MODES

Eleven channels are provided for 802.11b, 802.11g, 802.11n (HT20):

CHANNEL	FREQUENCY	CHANNEL	FREQUENCY
1	2412MHz	7	2442MHz
2	2417MHz	8	2447MHz
3	2422MHz	9	2452MHz
4	2427MHz	10	2457MHz
5	2432MHz	11	2462MHz
6	2437MHz		

Seven channels are provided for 802.11n (HT40):

CHANNEL	FREQUENCY	CHANNEL	FREQUENCY
3	2422MHz	7	2442MHz
4	2427MHz	8	2447MHz
5	2432MHz	9	2452MHz
6	2437MHz		



A D T

3.2.1 TEST MODE APPLICABILITY AND TESTED CHANNEL DETAIL

EUT CONFIGURE MODE	APPLICABLE TO					DESCRIPTION
	PLC	RE < 1G	RE ≥ 1G	APCM	OB	
-	√	√	√	√	√	-

Where **PLC**: Power Line Conducted Emission **RE < 1G**: Radiated Emission below 1GHz
RE ≥ 1G: Radiated Emission above 1GHz **APCM**: Antenna Port Conducted Measurement
OB: Conducted Out-Band Emission Measurement

POWER LINE CONDUCTED EMISSION TEST:

- Pre-Scan has been conducted to determine the worst-case mode from all possible combinations between available modulations, data rates and antenna ports (if EUT with antenna diversity architecture).
- Following channel(s) was (were) selected for the final test as listed below.

MODE	AVAILABLE CHANNEL	TESTED CHANNEL	MODULATION TECHNOLOGY	MODULATION TYPE	DATA RATE (Mbps)
802.11n (HT20)	1 to 11	11	OFDM	BPSK	19.5

RADIATED EMISSION TEST (BELOW 1 GHz):

- Pre-Scan has been conducted to determine the worst-case mode from all possible combinations between available modulations, data rates and antenna ports (if EUT with antenna diversity architecture).
- Following channel(s) was (were) selected for the final test as listed below.

MODE	AVAILABLE CHANNEL	TESTED CHANNEL	MODULATION TECHNOLOGY	MODULATION TYPE	DATA RATE (Mbps)
802.11n (HT20)	1 to 11	11	OFDM	BPSK	19.5



RADIATED EMISSION TEST (ABOVE 1 GHz):

- Pre-Scan has been conducted to determine the worst-case mode from all possible combinations between available modulations, data rates and antenna ports (if EUT with antenna diversity architecture).
- Following channel(s) was (were) selected for the final test as listed below.

MODE	AVAILABLE CHANNEL	TESTED CHANNEL	MODULATION TECHNOLOGY	MODULATION TYPE	DATA RATE (Mbps)
802.11b	1 to 11	1, 6, 11	DSSS	DBPSK	1
802.11g	1 to 11	1, 6, 11	OFDM	BPSK	6
802.11n (HT20)	1 to 11	1, 6, 11	OFDM	BPSK	19.5
802.11n (HT40)	3 to 9	3, 6, 9	OFDM	BPSK	40.5

ANTENNA PORT CONDUCTED MEASUREMENT:

- Pre-Scan has been conducted to determine the worst-case mode from all possible combinations between available modulations, data rates and antenna ports (if EUT with antenna diversity architecture).
- Following channel(s) was (were) selected for the final test as listed below.

MODE	AVAILABLE CHANNEL	TESTED CHANNEL	MODULATION TECHNOLOGY	MODULATION TYPE	DATA RATE (Mbps)
802.11b	1 to 11	1, 6, 11	DSSS	DBPSK	1
802.11g	1 to 11	1, 6, 11	OFDM	BPSK	6
802.11n (HT20)	1 to 11	1, 6, 11	OFDM	BPSK	19.5
802.11n (HT40)	3 to 9	3, 6, 9	OFDM	BPSK	40.5



A D T

CONDUCTED OUT-BAND EMISSION MEASUREMENT:

- Pre-Scan has been conducted to determine the worst-case mode from all possible combinations between available modulations, data rates and antenna ports (if EUT with antenna diversity architecture).
- Following channel(s) was (were) selected for the final test as listed below.

MODE	AVAILABLE CHANNEL	TESTED CHANNEL	MODULATION TECHNOLOGY	MODULATION TYPE	DATA RATE (Mbps)
802.11b	1 to 11	1, 6, 11	DSSS	DBPSK	1
802.11g	1 to 11	1, 6, 11	OFDM	BPSK	6
802.11n (HT20)	1 to 11	1, 6, 11	OFDM	BPSK	19.5
802.11n (HT40)	3 to 9	3, 6, 9	OFDM	BPSK	40.5

TEST CONDITION:

APPLICABLE TO	ENVIRONMENTAL CONDITIONS	INPUT POWER	TESTED BY
PLC	28deg. C, 58%RH	120Vac, 60Hz	Eagle Chen
RE<1G	24deg. C, 71%RH	120Vac, 60Hz	Chilin Lee
RE ³ 1G	25deg. C, 76%RH	120Vac, 60Hz	Evan Huang
APCM	25deg. C, 60%RH	120Vac, 60Hz	Nelson Teng James Chan
OB	25deg. C, 60%RH	120Vac, 60Hz	James Chan

3.3 GENERAL DESCRIPTION OF APPLIED STANDARDS

The EUT is a RF product. According to the specifications of the manufacturer, it must comply with the requirements of the following standards:

FCC Part 15, Subpart C (15.247)

558074 D01 DTS Meas Guidance v03r01

662911 D01 Multiple Transmitter Output v01 r02

ANSI C63.10-2009

All test items have been performed and recorded as per the above standards.

Note: The EUT is also considered as a kind of computer peripheral, because the connection to computer is necessary for typical use. It has been verified to comply with the requirements of FCC Part 15, Subpart B, Class B (DoC). The test report has been issued separately.



A D T

3.4 DESCRIPTION OF SUPPORT UNITS

The EUT has been tested as an independent unit together with other necessary accessories or support units. The following support units or accessories were used to form a representative test configuration during the tests.

NO.	PRODUCT	BRAND	MODEL NO.	SERIAL NO.	FCC ID
1	NOTEBOOK COMPUTER (For conducted emission test)	DELL	PP27L	6YLB32S	FCC DoC
	NOTEBOOK COMPUTER (For other test items)	DELL	PP32LA	FSLB32S	FCC DoC
2	TELEPHONE (For conducted emission test)	WONDER	WD-303	7C17KA05211	NA
	TELEPHONE (For other test items)	WONDER	WD-303	8C17DA02763	NA
3	TELEPHONE (For conducted emission test)	WONDER	WD-303	7C17KA04011	NA
	TELEPHONE (For other test items)	WONDER	WD-303	7C17KA04011	NA
4	SWITCH	HP	NA	NA	NA
5	TFTP SERVER	ASUS	NA	NA	NA
6	ARRIS C3 CMTS	ARRIS	NA	NA	NA
7	USB HDD	SanDisk	SDCZ2-512-A10	5472260816	FCC DoC
8	iPod	Apple	MC749TA/A	CC4DMFJUDFDM	NA

NO.	SIGNAL CABLE DESCRIPTION OF THE ABOVE SUPPORT UNITS
1	UTP cable (10m)
2	RJ-11 cable (1.5m) / RJ-11 cable (3m)
3	RJ-11 cable (1.5m) / RJ-11 cable (3m)
4	UTP cable (10m)
5	UTP cable (1m)
6	Coaxial cable (10m)
7	NA
8	USB cable (0.1m)

NOTE: All power cords of the above support units are non shielded (1.8m).

3.5 CONFIGURATION OF SYSTEM UNDER TEST

For Conducted emission test:

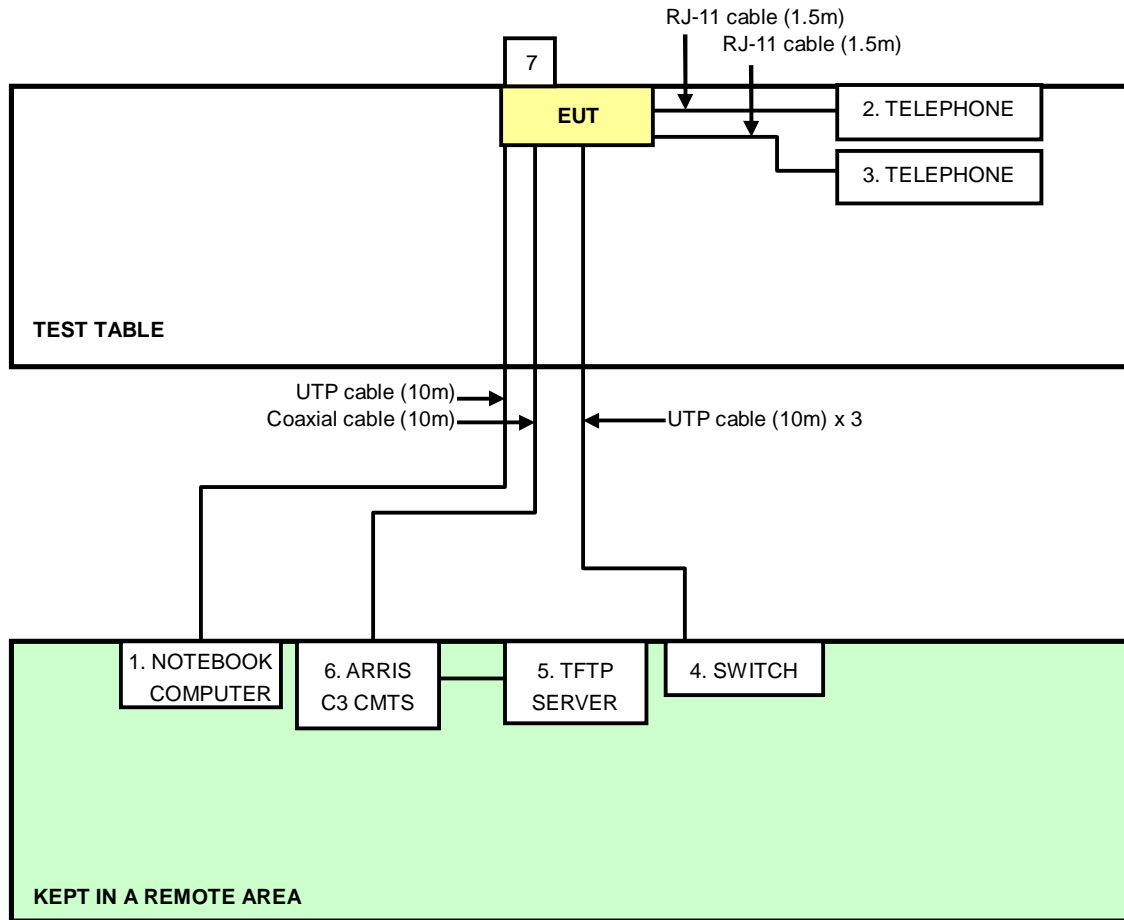

NOTE: The item 7 is support unit 7 (USB HDD)

For Other test items:

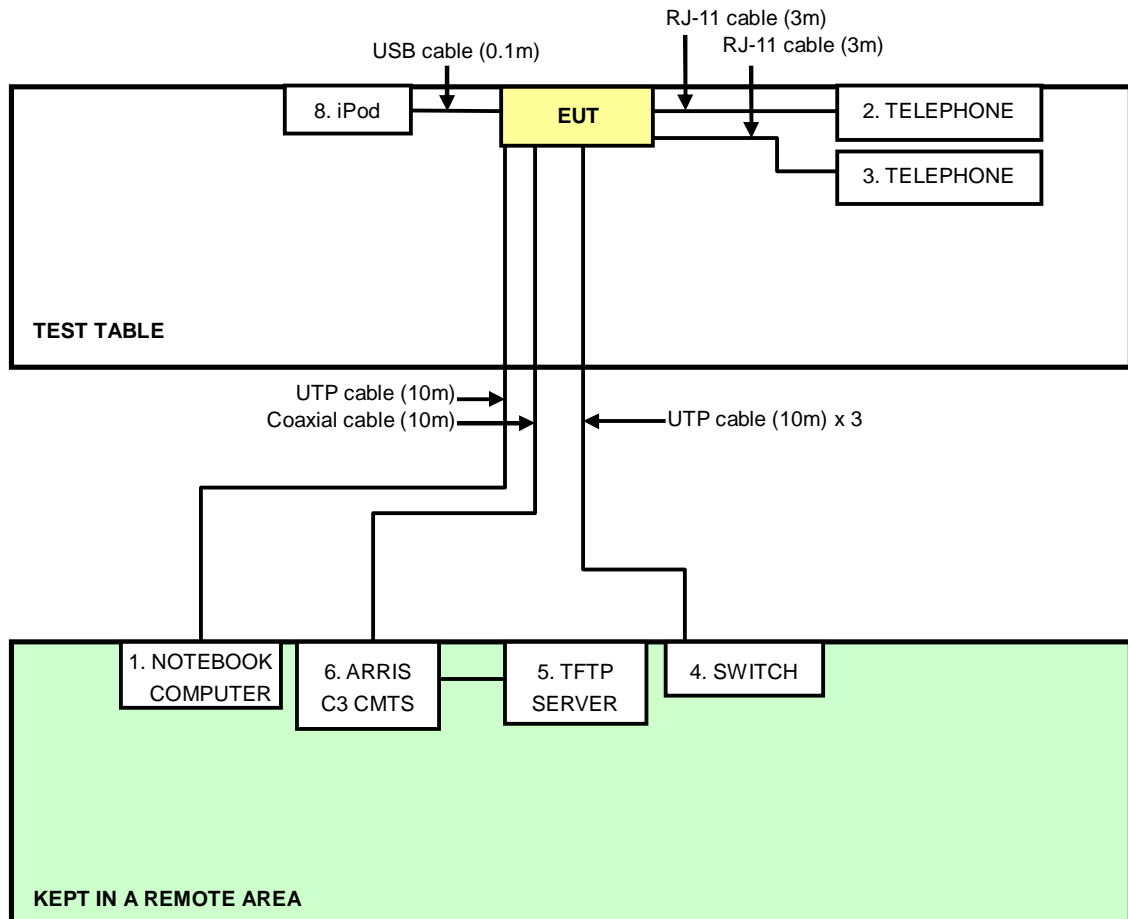



A D T

4. TEST TYPES AND RESULTS

4.1 CONDUCTED EMISSION MEASUREMENT

4.1.1 LIMITS OF CONDUCTED EMISSION MEASUREMENT

FREQUENCY OF EMISSION (MHz)	CONDUCTED LIMIT (dBµV)	
	Quasi-peak	Average
0.15-0.5	66 to 56	56 to 46
0.5-5	56	46
5-30	60	50

- NOTE:**
1. The lower limit shall apply at the transition frequencies.
 2. The limit decreases in line with the logarithm of the frequency in the range of 0.15 to 0.50 MHz.

4.1.2 TEST INSTRUMENTS

DESCRIPTION & MANUFACTURER	MODEL NO.	SERIAL NO.	CALIBRATED DATE	CALIBRATED UNTIL
Test Receiver ROHDE & SCHWARZ	ESCS 30	100287	Feb. 28, 2013	Feb. 27, 2014
Line-Impedance Stabilization Network (for EUT) SCHWARZBECK	NSLK 8127	8127-523	Sep. 24, 2012	Sep. 23, 2013
Line-Impedance Stabilization Network (for Peripheral) ROHDE & SCHWARZ	ESH3-Z5	8487731004	Oct. 29, 2012	Oct. 28, 2013
RF Cable (JYEBAO)	5DFB	COACAB-001	May 27, 2013	May 26, 2014
50 ohms Terminator	50	3	Oct. 16, 2012	Oct. 15, 2013
Software ADT	BV ADT_Cond_V7.3.7 .3	NA	NA	NA

Note:

1. The calibration interval of the above test instruments is 12 months and the calibrations are traceable to NML/ROC and NIST/USA.
2. The test was performed in Shielded Room No. A.
3. The VCCI Con A Registration No. is C-817.
4. Tested Date: Aug. 26, 2013

4.1.3 TEST PROCEDURES

- a. The EUT was placed 0.4 meters from the conducting wall of the shielded room with EUT being connected to the power mains through a line impedance stabilization network (LISN). Other support units were connected to the power mains through another LISN. The two LISNs provide 50 ohm/ 50uH of coupling impedance for the measuring instrument.
- b. Both lines of the power mains connected to the EUT were checked for maximum conducted interference.
- c. The frequency range from 150kHz to 30MHz was searched. Emission levels under (Limit - 20dB) were not recorded.

4.1.4 DEVIATION FROM TEST STANDARD

No deviation

4.1.5 TEST SETUP

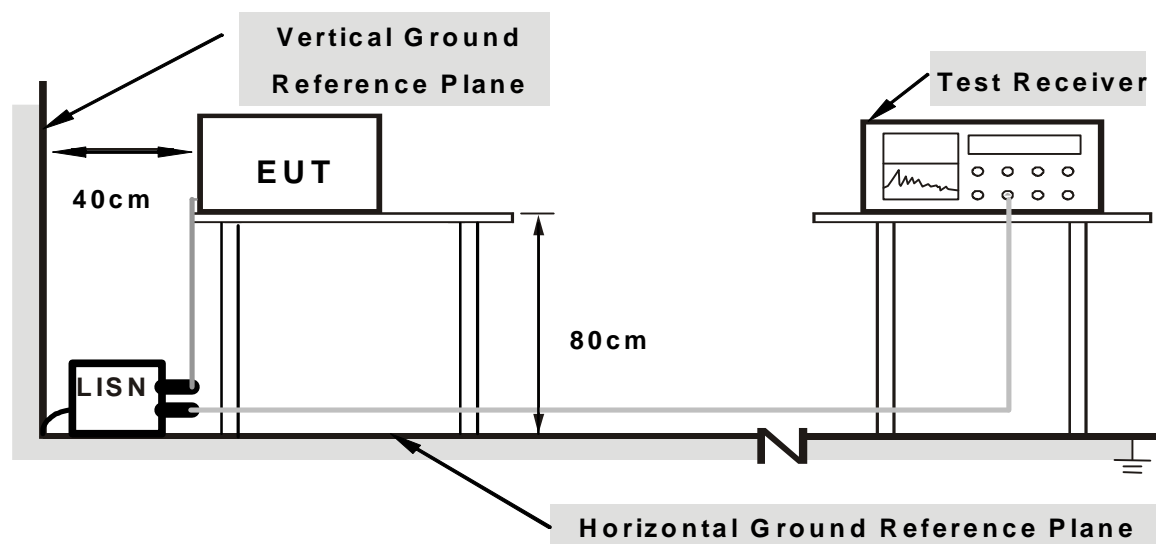

Note: 1. Support units were connected to second LISN.

For the actual test configuration, please refer to the related item – Photographs of the Test Configuration.



A D T

4.1.6 EUT OPERATING CONDITIONS

1. Turn on the power of EUT.
2. The communication partner run test program “RT3883QA.exe” to enable EUT under transmission/receiving condition continuously at specific channel frequency.

4.1.7 TEST RESULTS

PHASE	Line (L)	DETECTOR FUNCTION & BANDWIDTH	Quasi-Peak (QP) / Average (AV), 9 kHz
--------------	----------	--	---------------------------------------

No	Freq.	Corr.	Reading Value		Emission Level		Limit		Margin	
	[MHz]	Factor	[dB (uV)]		[dB (uV)]		[dB (uV)]		(dB)	
		(dB)	Q.P.	AV.	Q.P.	AV.	Q.P.	AV.	Q.P.	AV.
1	0.40456	0.15	44.42	34.46	44.57	34.61	57.76	47.76	-13.19	-13.15
2	0.49347	0.15	40.37	32.48	40.52	32.63	56.11	46.11	-15.59	-13.48
3	0.61534	0.16	40.53	31.67	40.69	31.83	56.00	46.00	-15.31	-14.17
4	0.80978	0.16	39.43	30.46	39.59	30.62	56.00	46.00	-16.41	-15.38
5	1.31072	0.18	38.95	28.42	39.13	28.60	56.00	46.00	-16.87	-17.40
6	3.32964	0.26	35.75	27.86	36.01	28.12	56.00	46.00	-19.99	-17.88

REMARKS:

1. Q.P. and AV. are abbreviations of quasi-peak and average individually.
2. The emission levels of other frequencies were very low against the limit.
3. Margin value = Emission level - Limit value
4. Correction factor = Insertion loss + Cable loss
5. Emission Level = Correction Factor + Reading Value.

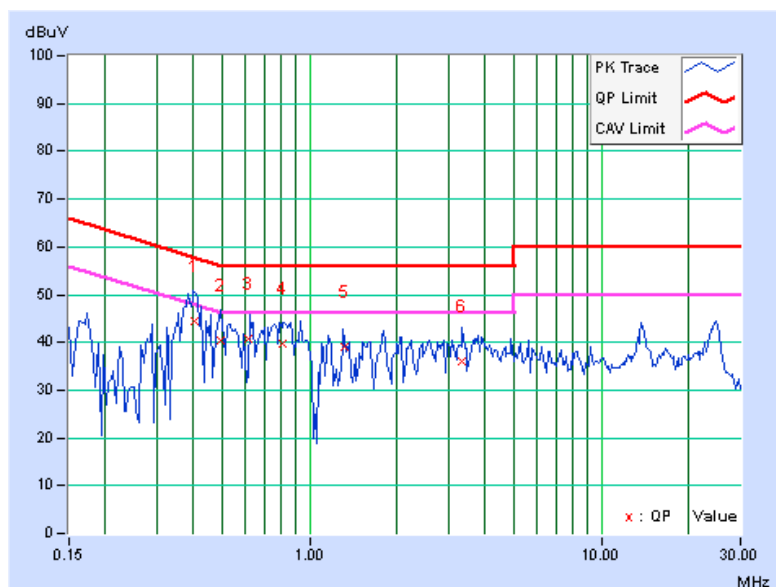

PHASE	Neutral (N)	DETECTOR FUNCTION & BANDWIDTH	Quasi-Peak (QP) / Average (AV), 9 kHz
--------------	-------------	--	---------------------------------------

No	Freq.	Corr.	Reading Value		Emission Level		Limit		Margin	
	[MHz]	Factor	[dB (uV)]		[dB (uV)]		[dB (uV)]		(dB)	
		(dB)	Q.P.	AV.	Q.P.	AV.	Q.P.	AV.	Q.P.	AV.
1	0.41965	0.18	45.47	38.79	45.65	38.97	57.46	47.46	-11.80	-8.48
2	0.52974	0.19	36.65	25.75	36.84	25.94	56.00	46.00	-19.16	-20.06
3	0.76596	0.20	39.37	30.46	39.57	30.66	56.00	46.00	-16.43	-15.34
4	1.43175	0.22	36.76	29.47	36.98	29.69	56.00	46.00	-19.02	-16.31
5	2.10286	0.24	35.67	28.64	35.91	28.88	56.00	46.00	-20.09	-17.12
6	4.12967	0.32	33.28	27.76	33.60	28.08	56.00	46.00	-22.40	-17.92

REMARKS:

1. Q.P. and AV. are abbreviations of quasi-peak and average individually.
2. The emission levels of other frequencies were very low against the limit.
3. Margin value = Emission level - Limit value
4. Correction factor = Insertion loss + Cable loss
5. Emission Level = Correction Factor + Reading Value.

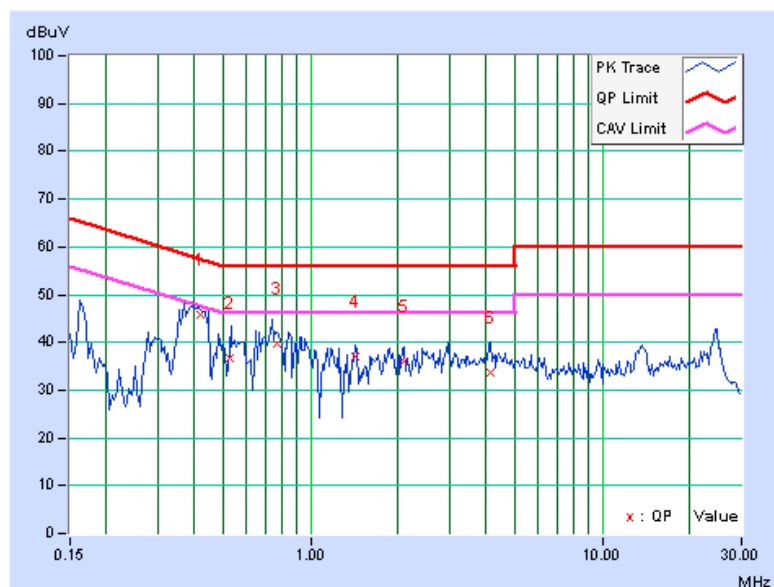



A D T

4.2 RADIATED EMISSION AND BANDEDGE MEASUREMENT

4.2.1 LIMITS OF RADIATED EMISSION AND BANDEDGE MEASUREMENT

Radiated emissions which fall in the restricted bands must comply with the radiated emission limits specified as below table. Other emissions shall be at least 20dB below the highest level of the desired power:

Frequencies (MHz)	Field strength (microvolts/meter)	Measurement distance (meters)
0.009-0.490	2400/F(kHz)	300
0.490-1.705	24000/F(kHz)	30
1.705-30.0	30	30
30-88	100	3
88-216	150	3
216-960	200	3
Above 960	500	3

NOTE:

1. The lower limit shall apply at the transition frequencies.
2. Emission level (dBuV/m) = 20 log Emission level (uV/m).
3. For frequencies above 1000MHz, the field strength limits are based on average detector, however, the peak field strength of any emission shall not exceed the maximum permitted average limits, specified above by more than 20dB.



A D T

4.2.2 TEST INSTRUMENTS

For Below 1GHz test:

DESCRIPTION & MANUFACTURER	MODEL NO.	SERIAL NO.	CALIBRATED DATE	CALIBRATED UNTIL
Spectrum Analyzer Agilent	E4446A	MY48250253	Sep. 03, 2012	Sep. 02, 2013
MXE EMI Receiver Agilent	N9038A	MY51210105	Jan. 29, 2013	Jan. 28, 2014
Pre-Amplifier Mini-Circuits	ZFL-1000VH2 B	AMP-ZFL-03	Nov. 14, 2012	Nov. 13, 2013
Pre-Amplifier Agilent	8449B	3008A02578	June 25, 2013	June 24, 2014
Pre-Amplifier SPACEK LABS	SLKKa-48-6	9K16	Nov. 14, 2012	Nov. 13, 2013
Trilog Broadband Antenna SCHWARZBECK	VULB 9168	9168-360	Mar. 19, 2013	Mar. 18, 2014
Horn_Antenna AISI	AIH.8018	0000320091110	Nov. 19, 2012	Nov. 18, 2013
Horn_Antenna SCHWARZBECK	BBHA 9170	9170-424	Oct. 12, 2012	Oct. 11, 2013
RF Cable	NA	RF104-201 RF104-203 RF104-204	Dec. 25, 2012	Dec. 24, 2013
RF Cable	NA	CHGCAB_001	Oct. 06, 2012	Oct. 05, 2013
Software	ADT_Radiated _V8.7.05	NA	NA	NA
Antenna Tower & Turn Table CT	NA	NA	NA	NA

Note:

1. The calibration interval of the above test instruments is 12 months and the calibrations are traceable to NML/ROC and NIST/USA.
2. The horn antenna, preamplifier (model: 8449B) are used only for the measurement of emission frequency above 1GHz if tested.
- 3 The test was performed in 966 Chamber No. G.
4. The FCC Site Registration No. is 966073.
- 5 The VCCI Site Registration No. is G-137.
- 6 The CANADA Site Registration No. is IC 7450H-2.
- 7 Tested Date: Aug. 26, 2013



A D T

For Above 1GHz test:

DESCRIPTION & MANUFACTURER	MODEL NO.	SERIAL NO.	CALIBRATED DATE	CALIBRATED UNTIL
Spectrum Analyzer Agilent	E4446A	MY48250253	Sep. 03, 2012	Sep. 02, 2013
Pre-Selector Agilent	N9039A	MY46520310	Sep. 03, 2012	Sep. 02, 2013
Signal Generator Agilent	N5181A	MY49060347	July 24, 2012	July 23, 2013
Pre-Amplifier Mini-Circuits	ZFL-1000VH2 B	AMP-ZFL-04	Nov. 15, 2011	Nov. 14, 2012
Pre-Amplifier Agilent	8449B	3008A02465	Feb. 27, 2012	Feb. 26, 2013
SPACEK LABS	SLKka-48-6	9K16	Nov. 15, 2011	Nov. 14, 2012
Trilog Broadband Antenna SCHWARZBECK	VULB 9168	9168-361	Apr. 06, 2012	Apr. 05, 2013
Horn_Antenna AISI	AIH.8018	0000220091110	Nov. 23, 2011	Nov. 22, 2012
Horn_Antenna SCHWARZBECK	BBHA 9170	9170-424	Oct. 12, 2012	Oct. 11, 2013
RF Cable	NA	RF104-205 RF104-207 RF104-202	Dec. 27, 2011	Dec. 26, 2012
RF Cable	NA	CHHCAB_001	Oct. 07, 2012	Oct. 06, 2013
Software	ADT_Radiated _V8.7.05	NA	NA	NA
Antenna Tower & Turn Table CT	NA	NA	NA	NA

Note:

1. The calibration interval of the above test instruments is 12 months and the calibrations are traceable to NML/ROC and NIST/USA.
2. The horn antenna, preamplifier (model: 8449B) are used only for the measurement of emission frequency above 1GHz if tested.
- 3 The test was performed in 966 Chamber No. H.
4. The FCC Site Registration No. is 797305.
- 5 The CANADA Site Registration No. is IC 7450H-3.
- 6 Tested Date: Nov. 10, 2012

4.2.3 TEST PROCEDURES

- a. The EUT was placed on the top of a rotating table 0.8 meters above the ground at 3 meter chamber. The table was rotated 360 degrees to determine the position of the highest radiation.
- b. The EUT was set 3 meters away from the interference-receiving antenna, which was mounted on the top of a variable-height antenna tower.
- c. The height of antenna is varied from one meter to four meters above the ground to determine the maximum value of the field strength. Both horizontal and vertical polarizations of the antenna are set to make the measurement.
- d. For each suspected emission, the EUT was arranged to its worst case and then the antenna was tuned to heights from 1 meter to 4 meters and the rotatable table was turned from 0 degrees to 360 degrees to find the maximum reading.
- e. The test-receiver system was set to quasi-peak detect function and specified bandwidth with maximum hold mode when the test frequency is below 1 GHz.
- f. The test-receiver system was set to peak and average detect function and specified bandwidth with maximum hold mode when the test frequency is above 1 GHz. If the peak reading value also meets average limit, measurement with the average detector is unnecessary.

NOTE:

1. The resolution bandwidth and video bandwidth of test receiver/spectrum analyzer is 120kHz for Quasi-peak detection (QP) at frequency below 1GHz.
2. The resolution bandwidth of test receiver/spectrum analyzer is 1 MHz and the video bandwidth is 3 MHz for Peak detection (PK) at frequency above 1GHz.
3. The resolution bandwidth of test receiver/spectrum analyzer is 1 MHz and the video bandwidth is 10 Hz for Average detection (AV) at frequency above 1GHz.
4. All modes of operation were investigated and the worst-case emissions are reported.

4.2.4 DEVIATION FROM TEST STANDARD

No deviation

4.2.5 TEST SETUP

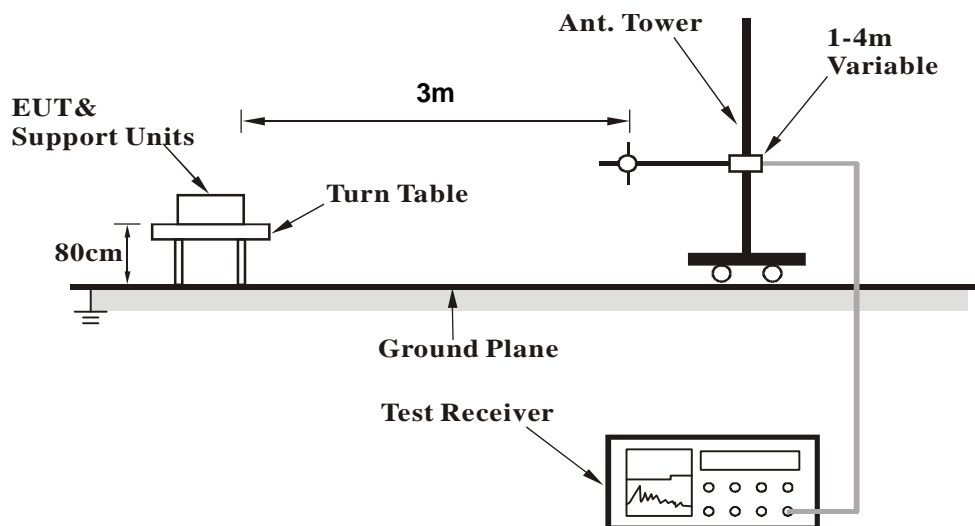

For the actual test configuration, please refer to the related item – Photographs of the Test Configuration.

4.2.6 EUT OPERATING CONDITIONS

Same as 4.1.6

4.2.7 TEST RESULTS

BELOW 1GHz WORST-CASE DATA

802.11n (HT20)

CHANNEL	TX Channel 11	DETECTOR FUNCTION	Quasi-Peak (QP)
FREQUENCY RANGE	Below 1GHz		

ANTENNA POLARITY & TEST DISTANCE: HORIZONTAL AT 3 M								
NO.	FREQ. (MHz)	EMISSION LEVEL (dBuV/m)	LIMIT (dBuV/m)	MARGIN (dB)	ANTENNA HEIGHT (m)	TABLE ANGLE (Degree)	RAW VALUE (dBuV)	CORRECTION FACTOR (dB/m)
1	77.33	18.7 QP	40.0	-21.3	1.50 H	360	36.39	-17.67
2	118.30	12.2 QP	43.5	-31.3	2.00 H	104	27.70	-15.47
3	291.07	25.4 QP	46.0	-20.6	1.00 H	141	38.44	-13.01
4	409.06	20.5 QP	46.0	-25.5	2.00 H	303	30.58	-10.07
5	892.67	28.4 QP	46.0	-17.6	1.50 H	221	28.97	-0.57
6	936.55	30.2 QP	46.0	-15.8	2.00 H	355	29.79	0.43
ANTENNA POLARITY & TEST DISTANCE: VERTICAL AT 3 M								
NO.	FREQ. (MHz)	EMISSION LEVEL (dBuV/m)	LIMIT (dBuV/m)	MARGIN (dB)	ANTENNA HEIGHT (m)	TABLE ANGLE (Degree)	RAW VALUE (dBuV)	CORRECTION FACTOR (dB/m)
1	76.08	22.4 QP	40.0	-17.6	2.00 V	168	39.93	-17.50
2	105.74	23.4 QP	43.5	-20.1	1.50 V	0	40.50	-17.10
3	170.22	19.5 QP	43.5	-24.0	1.00 V	284	33.19	-13.70
4	331.70	20.3 QP	46.0	-25.7	1.00 V	190	31.96	-11.70
5	398.31	31.3 QP	46.0	-14.7	1.00 V	206	41.56	-10.25
6	938.55	37.3 QP	46.0	-8.7	1.50 V	283	36.92	0.34

REMARKS:

1. Emission Level(dBuV/m) = Raw Value(dBuV) + Correction Factor(dB/m)
2. Correction Factor(dB/m) = Antenna Factor(dB/m) + Cable Factor(dB) – Pre-Amplifier Factor(dB)
3. The other emission levels were very low against the limit.
4. Margin value = Emission Level – Limit value



A D T

ABOVE 1GHz DATA

802.11b

CHANNEL	TX Channel 1	DETECTOR FUNCTION	Peak (PK)
FREQUENCY RANGE	1GHz ~ 25GHz		Average (AV)

ANTENNA POLARITY & TEST DISTANCE: HORIZONTAL AT 3 M

NO.	FREQ. (MHz)	EMISSION LEVEL (dBuV/m)	LIMIT (dBuV/m)	MARGIN (dB)	ANTENNA HEIGHT (m)	TABLE ANGLE (Degree)	RAW VALUE (dBuV)	CORRECTION FACTOR (dB/m)
1	2390.00	58.0 PK	74.0	-16.0	1.18 H	327	25.62	32.38
2	2390.00	48.1 AV	54.0	-5.9	1.18 H	327	15.72	32.38
3	*2412.00	104.2 PK			1.18 H	327	71.76	32.44
4	*2412.00	101.7 AV			1.18 H	327	69.26	32.44
5	4824.00	56.3 PK	74.0	-17.7	1.16 H	271	14.36	41.94
6	4824.00	53.0 AV	54.0	-1.0	1.16 H	271	11.06	41.94

ANTENNA POLARITY & TEST DISTANCE: VERTICAL AT 3 M

NO.	FREQ. (MHz)	EMISSION LEVEL (dBuV/m)	LIMIT (dBuV/m)	MARGIN (dB)	ANTENNA HEIGHT (m)	TABLE ANGLE (Degree)	RAW VALUE (dBuV)	CORRECTION FACTOR (dB/m)
1	2390.00	63.1 PK	74.0	-10.9	1.00 V	177	30.72	32.38
2	2390.00	53.4 AV	54.0	-0.6	1.00 V	177	21.02	32.38
3	*2412.00	110.5 PK			1.00 V	177	78.06	32.44
4	*2412.00	108.1 AV			1.00 V	177	75.66	32.44
5	4824.00	56.8 PK	74.0	-17.2	1.03 V	100	14.86	41.94
6	4824.00	53.5 AV	54.0	-0.5	1.03 V	100	11.56	41.94

REMARKS:

1. Emission Level(dBuV/m) = Raw Value(dBuV) + Correction Factor(dB/m)
2. Correction Factor(dB/m) = Antenna Factor(dB/m) + Cable Factor(dB) – Pre-Amplifier Factor(dB)
3. The other emission levels were very low against the limit.
4. Margin value = Emission Level – Limit value
5. " * ": Fundamental frequency.



A D T

CHANNEL	TX Channel 6	DETECTOR FUNCTION	Peak (PK)
FREQUENCY RANGE	1GHz ~ 25GHz		Average (AV)

ANTENNA POLARITY & TEST DISTANCE: HORIZONTAL AT 3 M

NO.	FREQ. (MHz)	EMISSION LEVEL (dBuV/m)	LIMIT (dBuV/m)	MARGIN (dB)	ANTENNA HEIGHT (m)	TABLE ANGLE (Degree)	RAW VALUE (dBuV)	CORRECTION FACTOR (dB/m)
1	2381.70	56.6 PK	74.0	-17.4	1.20 H	332	24.25	32.35
2	2381.70	44.9 AV	54.0	-9.1	1.20 H	332	12.55	32.35
3	*2437.00	103.4 PK			1.20 H	332	70.89	32.51
4	*2437.00	101.1 AV			1.20 H	332	68.59	32.51
5	2490.73	57.3 PK	74.0	-16.7	1.20 H	332	24.65	32.65
6	2490.73	44.5 AV	54.0	-9.5	1.20 H	332	11.85	32.65
7	4874.00	56.1 PK	74.0	-17.9	1.14 H	268	14.11	41.99
8	4874.00	52.8 AV	54.0	-1.2	1.14 H	268	10.81	41.99
9	7311.00	54.8 PK	74.0	-19.2	1.51 H	143	8.27	46.53
10	7311.00	43.8 AV	54.0	-10.2	1.51 H	143	-2.73	46.53

ANTENNA POLARITY & TEST DISTANCE: VERTICAL AT 3 M

NO.	FREQ. (MHz)	EMISSION LEVEL (dBuV/m)	LIMIT (dBuV/m)	MARGIN (dB)	ANTENNA HEIGHT (m)	TABLE ANGLE (Degree)	RAW VALUE (dBuV)	CORRECTION FACTOR (dB/m)
1	2381.70	62.2 PK	74.0	-11.8	1.00 V	205	29.85	32.35
2	2381.70	51.4 AV	54.0	-2.6	1.00 V	205	19.05	32.35
3	*2437.00	110.2 PK			1.00 V	188	77.69	32.51
4	*2437.00	107.9 AV			1.00 V	188	75.39	32.51
5	2490.73	59.8 PK	74.0	-14.2	1.00 V	169	27.15	32.65
6	2490.73	48.7 AV	54.0	-5.3	1.00 V	169	16.05	32.65
7	4874.00	56.8 PK	74.0	-17.2	1.04 V	105	14.81	41.99
8	4874.00	53.2 AV	54.0	-0.8	1.04 V	105	11.21	41.99
9	7311.00	56.4 PK	74.0	-17.6	1.00 V	35	9.87	46.53
10	7311.00	41.9 AV	54.0	-12.1	1.00 V	35	-4.63	46.53

REMARKS:

1. Emission Level(dBuV/m) = Raw Value(dBuV) + Correction Factor(dB/m)
2. Correction Factor(dB/m) = Antenna Factor(dB/m) + Cable Factor(dB) – Pre-Amplifier Factor(dB)
3. The other emission levels were very low against the limit.
4. Margin value = Emission Level – Limit value
5. " * ": Fundamental frequency.



A D T

CHANNEL	TX Channel 11	DETECTOR FUNCTION	Peak (PK)
FREQUENCY RANGE	1GHz ~ 25GHz		Average (AV)

ANTENNA POLARITY & TEST DISTANCE: HORIZONTAL AT 3 M

NO.	FREQ. (MHz)	EMISSION LEVEL (dBuV/m)	LIMIT (dBuV/m)	MARGIN (dB)	ANTENNA HEIGHT (m)	TABLE ANGLE (Degree)	RAW VALUE (dBuV)	CORRECTION FACTOR (dB/m)
1	*2462.00	103.1 PK			1.15 H	325	70.53	32.57
2	*2462.00	100.6 AV			1.15 H	325	68.03	32.57
3	2484.08	58.8 PK	74.0	-15.2	1.15 H	325	26.17	32.63
4	2484.08	48.9 AV	54.0	-5.1	1.15 H	325	16.27	32.63
5	4924.00	56.5 PK	74.0	-17.5	1.13 H	271	14.49	42.01
6	4924.00	53.2 AV	54.0	-0.8	1.13 H	271	11.19	42.01
7	7386.00	55.1 PK	74.0	-18.9	1.50 H	137	8.37	46.73
8	7386.00	44.1 AV	54.0	-9.9	1.50 H	137	-2.63	46.73

ANTENNA POLARITY & TEST DISTANCE: VERTICAL AT 3 M

NO.	FREQ. (MHz)	EMISSION LEVEL (dBuV/m)	LIMIT (dBuV/m)	MARGIN (dB)	ANTENNA HEIGHT (m)	TABLE ANGLE (Degree)	RAW VALUE (dBuV)	CORRECTION FACTOR (dB/m)
1	*2462.00	109.1 PK			1.00 V	182	76.53	32.57
2	*2462.00	106.6 AV			1.00 V	182	74.03	32.57
3	2484.08	61.0 PK	74.0	-13.0	1.00 V	182	28.37	32.63
4	2484.08	50.5 AV	54.0	-3.5	1.00 V	182	17.87	32.63
5	4924.00	56.6 PK	74.0	-17.4	1.15 V	104	14.59	42.01
6	4924.00	53.1 AV	54.0	-0.9	1.15 V	104	11.09	42.01
7	7386.00	56.7 PK	74.0	-17.3	1.00 V	43	9.97	46.73
8	7386.00	42.1 AV	54.0	-11.9	1.00 V	43	-4.63	46.73

REMARKS:

1. Emission Level(dBuV/m) = Raw Value(dBuV) + Correction Factor(dB/m)
2. Correction Factor(dB/m) = Antenna Factor(dB/m) + Cable Factor(dB) – Pre-Amplifier Factor(dB)
3. The other emission levels were very low against the limit.
4. Margin value = Emission Level – Limit value
5. " * ": Fundamental frequency.



A D T

802.11g

CHANNEL	TX Channel 1	DETECTOR FUNCTION	Peak (PK)
FREQUENCY RANGE	1GHz ~ 25GHz		Average (AV)

ANTENNA POLARITY & TEST DISTANCE: HORIZONTAL AT 3 M

NO.	FREQ. (MHz)	EMISSION LEVEL (dBuV/m)	LIMIT (dBuV/m)	MARGIN (dB)	ANTENNA HEIGHT (m)	TABLE ANGLE (Degree)	RAW VALUE (dBuV)	CORRECTION FACTOR (dB/m)
1	2390.00	63.9 PK	74.0	-10.1	1.37 H	126	31.52	32.38
2	2390.00	48.8 AV	54.0	-5.2	1.37 H	126	16.42	32.38
3	*2412.00	104.1 PK			1.37 H	126	71.66	32.44
4	*2412.00	93.4 AV			1.37 H	126	60.96	32.44
5	4824.00	47.3 PK	74.0	-26.7	1.00 H	278	5.36	41.94
6	4824.00	36.9 AV	54.0	-17.1	1.00 H	278	-5.04	41.94

ANTENNA POLARITY & TEST DISTANCE: VERTICAL AT 3 M

NO.	FREQ. (MHz)	EMISSION LEVEL (dBuV/m)	LIMIT (dBuV/m)	MARGIN (dB)	ANTENNA HEIGHT (m)	TABLE ANGLE (Degree)	RAW VALUE (dBuV)	CORRECTION FACTOR (dB/m)
1	2390.00	68.2 PK	74.0	-5.8	1.00 V	192	35.82	32.38
2	2390.00	52.4 AV	54.0	-1.6	1.00 V	192	20.02	32.38
3	*2412.00	112.4 PK			1.00 V	192	79.96	32.44
4	*2412.00	101.7 AV			1.00 V	192	69.26	32.44
5	4824.00	47.6 PK	74.0	-26.4	1.00 V	152	5.66	41.94
6	4824.00	36.8 AV	54.0	-17.2	1.00 V	152	-5.14	41.94

REMARKS:

1. Emission Level(dBuV/m) = Raw Value(dBuV) + Correction Factor(dB/m)
2. Correction Factor(dB/m) = Antenna Factor(dB/m) + Cable Factor(dB) – Pre-Amplifier Factor(dB)
3. The other emission levels were very low against the limit.
4. Margin value = Emission Level – Limit value
5. " * ": Fundamental frequency.



A D T

CHANNEL	TX Channel 6	DETECTOR FUNCTION	Peak (PK)
FREQUENCY RANGE	1GHz ~ 25GHz		Average (AV)

ANTENNA POLARITY & TEST DISTANCE: HORIZONTAL AT 3 M

NO.	FREQ. (MHz)	EMISSION LEVEL (dBuV/m)	LIMIT (dBuV/m)	MARGIN (dB)	ANTENNA HEIGHT (m)	TABLE ANGLE (Degree)	RAW VALUE (dBuV)	CORRECTION FACTOR (dB/m)
1	2384.80	59.6 PK	74.0	-14.4	1.35 H	129	27.24	32.36
2	2384.80	46.7 AV	54.0	-7.3	1.35 H	129	14.34	32.36
3	*2437.00	105.8 PK			1.35 H	129	73.29	32.51
4	*2437.00	94.7 AV			1.35 H	129	62.19	32.51
5	2489.30	58.8 PK	74.0	-15.2	1.38 H	129	26.16	32.64
6	2489.30	45.3 AV	54.0	-8.7	1.38 H	129	12.66	32.64
7	4874.00	48.1 PK	74.0	-25.9	1.00 H	281	6.11	41.99
8	4874.00	37.1 AV	54.0	-16.9	1.00 H	281	-4.89	41.99
9	7311.00	55.1 PK	74.0	-18.9	1.00 H	169	8.57	46.53
10	7311.00	43.9 AV	54.0	-10.1	1.00 H	169	-2.63	46.53

ANTENNA POLARITY & TEST DISTANCE: VERTICAL AT 3 M

NO.	FREQ. (MHz)	EMISSION LEVEL (dBuV/m)	LIMIT (dBuV/m)	MARGIN (dB)	ANTENNA HEIGHT (m)	TABLE ANGLE (Degree)	RAW VALUE (dBuV)	CORRECTION FACTOR (dB/m)
1	2384.80	63.0 PK	74.0	-11.0	1.00 V	177	30.64	32.36
2	2384.80	53.4 AV	54.0	-0.6	1.00 V	177	21.04	32.36
3	*2437.00	114.2 PK			1.00 V	177	81.69	32.51
4	*2437.00	103.5 AV			1.00 V	177	70.99	32.51
5	2489.30	61.7 PK	74.0	-12.3	1.00 V	177	29.06	32.64
6	2489.30	50.7 AV	54.0	-3.3	1.00 V	177	18.06	32.64
7	4874.00	48.1 PK	74.0	-25.9	1.00 V	155	6.11	41.99
8	4874.00	37.1 AV	54.0	-16.9	1.00 V	155	-4.89	41.99
9	7311.00	54.9 PK	74.0	-19.1	1.00 V	132	8.37	46.53
10	7311.00	41.9 AV	54.0	-12.1	1.00 V	132	-4.63	46.53

REMARKS:

1. Emission Level(dBuV/m) = Raw Value(dBuV) + Correction Factor(dB/m)
2. Correction Factor(dB/m) = Antenna Factor(dB/m) + Cable Factor(dB) – Pre-Amplifier Factor(dB)
3. The other emission levels were very low against the limit.
4. Margin value = Emission Level – Limit value
5. " * ": Fundamental frequency.

CHANNEL	TX Channel 11	DETECTOR FUNCTION	Peak (PK)
FREQUENCY RANGE	1GHz ~ 25GHz		Average (AV)

ANTENNA POLARITY & TEST DISTANCE: HORIZONTAL AT 3 M

NO.	FREQ. (MHz)	EMISSION LEVEL (dBuV/m)	LIMIT (dBuV/m)	MARGIN (dB)	ANTENNA HEIGHT (m)	TABLE ANGLE (Degree)	RAW VALUE (dBuV)	CORRECTION FACTOR (dB/m)
1	*2462.00	105.4 PK			1.33 H	123	72.83	32.57
2	*2462.00	94.6 AV			1.33 H	123	62.03	32.57
3	2483.50	63.2 PK	74.0	-10.8	1.33 H	123	30.57	32.63
4	2483.50	47.4 AV	54.0	-6.6	1.33 H	123	14.77	32.63
5	4924.00	47.6 PK	74.0	-26.4	1.00 H	283	5.59	42.01
6	4924.00	36.7 AV	54.0	-17.3	1.00 H	283	-5.31	42.01
7	7386.00	55.6 PK	74.0	-18.4	1.00 H	166	8.87	46.73
8	7386.00	43.5 AV	54.0	-10.5	1.00 H	166	-3.23	46.73

ANTENNA POLARITY & TEST DISTANCE: VERTICAL AT 3 M

NO.	FREQ. (MHz)	EMISSION LEVEL (dBuV/m)	LIMIT (dBuV/m)	MARGIN (dB)	ANTENNA HEIGHT (m)	TABLE ANGLE (Degree)	RAW VALUE (dBuV)	CORRECTION FACTOR (dB/m)
1	*2462.00	114.2 PK			1.00 V	179	81.63	32.57
2	*2462.00	103.4 AV			1.00 V	179	70.83	32.57
3	2483.50	69.8 PK	74.0	-4.2	1.00 V	179	37.17	32.63
4	2483.50	53.0 AV	54.0	-1.0	1.00 V	179	20.37	32.63
5	4924.00	47.9 PK	74.0	-26.1	1.00 V	155	5.89	42.01
6	4924.00	36.9 AV	54.0	-17.1	1.00 V	155	-5.11	42.01
7	7386.00	54.5 PK	74.0	-19.5	1.00 V	135	7.77	46.73
8	7386.00	42.1 AV	54.0	-11.9	1.00 V	135	-4.63	46.73

REMARKS:

1. Emission Level(dBuV/m) = Raw Value(dBuV) + Correction Factor(dB/m)
2. Correction Factor(dB/m) = Antenna Factor(dB/m) + Cable Factor(dB) – Pre-Amplifier Factor(dB)
3. The other emission levels were very low against the limit.
4. Margin value = Emission Level – Limit value
5. " * ": Fundamental frequency.



A D T

802.11n (HT20)

CHANNEL	TX Channel 1	DETECTOR FUNCTION	Peak (PK)
FREQUENCY RANGE	1GHz ~ 25GHz		Average (AV)

ANTENNA POLARITY & TEST DISTANCE: HORIZONTAL AT 3 M

NO.	FREQ. (MHz)	EMISSION LEVEL (dBuV/m)	LIMIT (dBuV/m)	MARGIN (dB)	ANTENNA HEIGHT (m)	TABLE ANGLE (Degree)	RAW VALUE (dBuV)	CORRECTION FACTOR (dB/m)
1	2360.40	64.4 PK	74.0	-9.6	1.31 H	62	32.12	32.28
2	2360.40	53.2 AV	54.0	-0.8	1.31 H	62	20.92	32.28
3	*2412.00	113.7 PK			1.31 H	62	81.26	32.44
4	*2412.00	101.6 AV			1.31 H	62	69.16	32.44
5	4824.00	46.7 PK	74.0	-27.3	1.14 H	143	4.76	41.94
6	4824.00	36.0 AV	54.0	-18.0	1.14 H	143	-5.94	41.94

ANTENNA POLARITY & TEST DISTANCE: VERTICAL AT 3 M

NO.	FREQ. (MHz)	EMISSION LEVEL (dBuV/m)	LIMIT (dBuV/m)	MARGIN (dB)	ANTENNA HEIGHT (m)	TABLE ANGLE (Degree)	RAW VALUE (dBuV)	CORRECTION FACTOR (dB/m)
1	2390.00	62.1 PK	74.0	-11.9	1.00 V	180	29.72	32.38
2	2390.00	51.6 AV	54.0	-2.4	1.00 V	180	19.22	32.38
3	*2412.00	112.0 PK			1.00 V	180	79.56	32.44
4	*2412.00	100.6 AV			1.00 V	180	68.16	32.44
5	4824.00	47.1 PK	74.0	-26.9	1.49 V	326	5.16	41.94
6	4824.00	35.8 AV	54.0	-18.2	1.49 V	326	-6.14	41.94

REMARKS:

1. Emission Level(dBuV/m) = Raw Value(dBuV) + Correction Factor(dB/m)
2. Correction Factor(dB/m) = Antenna Factor(dB/m) + Cable Factor(dB) – Pre-Amplifier Factor(dB)
3. The other emission levels were very low against the limit.
4. Margin value = Emission Level – Limit value
5. " * ": Fundamental frequency.



A D T

CHANNEL	TX Channel 6	DETECTOR FUNCTION	Peak (PK)
FREQUENCY RANGE	1GHz ~ 25GHz		Average (AV)

ANTENNA POLARITY & TEST DISTANCE: HORIZONTAL AT 3 M

NO.	FREQ. (MHz)	EMISSION LEVEL (dBuV/m)	LIMIT (dBuV/m)	MARGIN (dB)	ANTENNA HEIGHT (m)	TABLE ANGLE (Degree)	RAW VALUE (dBuV)	CORRECTION FACTOR (dB/m)
1	2385.00	65.0 PK	74.0	-9.0	1.33 H	86	32.64	32.36
2	2385.00	53.4 AV	54.0	-0.6	1.33 H	86	21.04	32.36
3	*2437.00	114.5 PK			1.27 H	67	81.99	32.51
4	*2437.00	102.0 AV			1.27 H	67	69.49	32.51
5	2489.04	62.7 PK	74.0	-11.3	1.24 H	88	30.06	32.64
6	2489.04	50.7 AV	54.0	-3.3	1.24 H	88	18.06	32.64
7	4874.00	47.9 PK	74.0	-26.1	1.15 H	162	5.91	41.99
8	4874.00	36.8 AV	54.0	-17.2	1.15 H	162	-5.19	41.99
9	7311.00	54.1 PK	74.0	-19.9	1.00 H	20	7.57	46.53
10	7311.00	42.1 AV	54.0	-11.9	1.00 H	20	-4.43	46.53

ANTENNA POLARITY & TEST DISTANCE: VERTICAL AT 3 M

NO.	FREQ. (MHz)	EMISSION LEVEL (dBuV/m)	LIMIT (dBuV/m)	MARGIN (dB)	ANTENNA HEIGHT (m)	TABLE ANGLE (Degree)	RAW VALUE (dBuV)	CORRECTION FACTOR (dB/m)
1	2385.10	64.1 PK	74.0	-9.9	1.00 V	182	31.74	32.36
2	2385.10	51.9 AV	54.0	-2.1	1.00 V	182	19.54	32.36
3	*2437.00	110.6 PK			1.00 V	171	78.09	32.51
4	*2437.00	99.7 AV			1.00 V	171	67.19	32.51
5	2488.92	60.1 PK	74.0	-13.9	1.00 V	163	27.46	32.64
6	2488.92	49.0 AV	54.0	-5.0	1.00 V	163	16.36	32.64
7	4874.00	47.3 PK	74.0	-26.7	1.48 V	307	5.31	41.99
8	4874.00	35.7 AV	54.0	-18.3	1.48 V	307	-6.29	41.99
9	7311.00	53.4 PK	74.0	-20.6	1.24 V	144	6.87	46.53
10	7311.00	41.5 AV	54.0	-12.5	1.24 V	144	-5.03	46.53

REMARKS:

1. Emission Level(dBuV/m) = Raw Value(dBuV) + Correction Factor(dB/m)
2. Correction Factor(dB/m) = Antenna Factor(dB/m) + Cable Factor(dB) – Pre-Amplifier Factor(dB)
3. The other emission levels were very low against the limit.
4. Margin value = Emission Level – Limit value
5. " * ": Fundamental frequency.

CHANNEL	TX Channel 11	DETECTOR FUNCTION	Peak (PK)
FREQUENCY RANGE	1GHz ~ 25GHz		Average (AV)

ANTENNA POLARITY & TEST DISTANCE: HORIZONTAL AT 3 M								
NO.	FREQ. (MHz)	EMISSION LEVEL (dBuV/m)	LIMIT (dBuV/m)	MARGIN (dB)	ANTENNA HEIGHT (m)	TABLE ANGLE (Degree)	RAW VALUE (dBuV)	CORRECTION FACTOR (dB/m)
1	*2462.00	115.8 PK			1.26 H	87	83.23	32.57
2	*2462.00	103.2 AV			1.26 H	87	70.63	32.57
3	2483.50	68.5 PK	74.0	-5.5	1.26 H	87	35.87	32.63
4	2483.50	53.2 AV	54.0	-0.8	1.26 H	87	20.57	32.63
5	4924.00	47.4 PK	74.0	-26.6	1.08 H	170	5.39	42.01
6	4924.00	36.4 AV	54.0	-17.6	1.08 H	170	-5.61	42.01
7	7386.00	54.4 PK	74.0	-19.6	1.04 H	17	7.67	46.73
8	7386.00	42.5 AV	54.0	-11.5	1.04 H	17	-4.23	46.73

ANTENNA POLARITY & TEST DISTANCE: VERTICAL AT 3 M								
NO.	FREQ. (MHz)	EMISSION LEVEL (dBuV/m)	LIMIT (dBuV/m)	MARGIN (dB)	ANTENNA HEIGHT (m)	TABLE ANGLE (Degree)	RAW VALUE (dBuV)	CORRECTION FACTOR (dB/m)
1	*2462.00	111.2 PK			1.00 V	178	78.63	32.57
2	*2462.00	100.4 AV			1.00 V	178	67.83	32.57
3	2483.50	65.4 PK	74.0	-8.6	1.00 V	178	32.77	32.63
4	2483.50	49.1 AV	54.0	-4.9	1.00 V	178	16.47	32.63
5	4924.00	47.4 PK	74.0	-26.6	1.48 V	335	5.39	42.01
6	4924.00	35.8 AV	54.0	-18.2	1.48 V	335	-6.21	42.01
7	7386.00	54.4 PK	74.0	-19.6	1.28 V	148	7.67	46.73
8	7386.00	42.3 AV	54.0	-11.7	1.28 V	148	-4.43	46.73

REMARKS:

1. Emission Level(dBuV/m) = Raw Value(dBuV) + Correction Factor(dB/m)
2. Correction Factor(dB/m) = Antenna Factor(dB/m) + Cable Factor(dB) – Pre-Amplifier Factor(dB)
3. The other emission levels were very low against the limit.
4. Margin value = Emission Level – Limit value
5. " * ": Fundamental frequency.



A D T

802.11n (HT40)

CHANNEL	TX Channel 3	DETECTOR FUNCTION	Peak (PK)
FREQUENCY RANGE	1GHz ~ 25GHz		Average (AV)

ANTENNA POLARITY & TEST DISTANCE: HORIZONTAL AT 3 M

NO.	FREQ. (MHz)	EMISSION LEVEL (dBuV/m)	LIMIT (dBuV/m)	MARGIN (dB)	ANTENNA HEIGHT (m)	TABLE ANGLE (Degree)	RAW VALUE (dBuV)	CORRECTION FACTOR (dB/m)
1	2390.00	73.1 PK	74.0	-0.9	1.31 H	65	40.72	32.38
2	2390.00	52.6 AV	54.0	-1.4	1.31 H	65	20.22	32.38
3	*2422.00	107.8 PK			1.32 H	84	75.33	32.47
4	*2422.00	94.2 AV			1.32 H	84	61.73	32.47
5	4844.00	47.2 PK	74.0	-26.8	1.09 H	159	5.24	41.96
6	4844.00	36.3 AV	54.0	-17.7	1.09 H	159	-5.66	41.96
7	7266.00	54.1 PK	74.0	-19.9	1.00 H	31	7.70	46.40
8	7266.00	42.3 AV	54.0	-11.7	1.00 H	31	-4.10	46.40

ANTENNA POLARITY & TEST DISTANCE: VERTICAL AT 3 M

NO.	FREQ. (MHz)	EMISSION LEVEL (dBuV/m)	LIMIT (dBuV/m)	MARGIN (dB)	ANTENNA HEIGHT (m)	TABLE ANGLE (Degree)	RAW VALUE (dBuV)	CORRECTION FACTOR (dB/m)
1	2390.00	64.9 PK	74.0	-9.1	1.00 V	169	32.52	32.38
2	2390.00	48.9 AV	54.0	-5.1	1.00 V	169	16.52	32.38
3	*2422.00	101.6 PK			1.00 V	169	69.13	32.47
4	*2422.00	90.5 AV			1.00 V	169	58.03	32.47
5	4844.00	47.5 PK	74.0	-26.5	1.53 V	321	5.54	41.96
6	4844.00	36.1 AV	54.0	-17.9	1.53 V	321	-5.86	41.96
7	7266.00	53.8 PK	74.0	-20.2	1.23 V	155	7.40	46.40
8	7266.00	41.9 AV	54.0	-12.1	1.23 V	155	-4.50	46.40

REMARKS:

1. Emission Level(dBuV/m) = Raw Value(dBuV) + Correction Factor(dB/m)
2. Correction Factor(dB/m) = Antenna Factor(dB/m) + Cable Factor(dB) – Pre-Amplifier Factor(dB)
3. The other emission levels were very low against the limit.
4. Margin value = Emission Level – Limit value
5. " * ": Fundamental frequency.



A D T

CHANNEL	TX Channel 6	DETECTOR FUNCTION	Peak (PK)
FREQUENCY RANGE	1GHz ~ 25GHz		Average (AV)

ANTENNA POLARITY & TEST DISTANCE: HORIZONTAL AT 3 M

NO.	FREQ. (MHz)	EMISSION LEVEL (dBuV/m)	LIMIT (dBuV/m)	MARGIN (dB)	ANTENNA HEIGHT (m)	TABLE ANGLE (Degree)	RAW VALUE (dBuV)	CORRECTION FACTOR (dB/m)
1	2390.00	68.5 PK	74.0	-5.5	1.34 H	93	36.12	32.38
2	2390.00	53.3 AV	54.0	-0.7	1.34 H	93	20.92	32.38
3	*2437.00	114.4 PK			1.29 H	86	81.89	32.51
4	*2437.00	101.2 AV			1.29 H	86	68.69	32.51
5	2483.50	66.9 PK	74.0	-7.1	1.27 H	84	34.27	32.63
6	2483.50	51.1 AV	54.0	-2.9	1.27 H	84	18.47	32.63
7	4874.00	48.1 PK	74.0	-25.9	1.12 H	156	6.11	41.99
8	4874.00	36.6 AV	54.0	-17.4	1.12 H	156	-5.39	41.99
9	7311.00	54.5 PK	74.0	-19.5	1.00 H	26	7.97	46.53
10	7311.00	42.6 AV	54.0	-11.4	1.00 H	26	-3.93	46.53

ANTENNA POLARITY & TEST DISTANCE: VERTICAL AT 3 M

NO.	FREQ. (MHz)	EMISSION LEVEL (dBuV/m)	LIMIT (dBuV/m)	MARGIN (dB)	ANTENNA HEIGHT (m)	TABLE ANGLE (Degree)	RAW VALUE (dBuV)	CORRECTION FACTOR (dB/m)
1	2390.00	64.5 PK	74.0	-9.5	1.00 V	172	32.12	32.38
2	2390.00	48.3 AV	54.0	-5.7	1.00 V	172	15.92	32.38
3	*2437.00	109.5 PK			1.00 V	172	76.99	32.51
4	*2437.00	96.6 AV			1.00 V	172	64.09	32.51
5	2483.50	61.3 PK	74.0	-12.7	1.00 V	172	28.67	32.63
6	2483.50	46.5 AV	54.0	-7.5	1.00 V	172	13.87	32.63
7	4874.00	48.3 PK	74.0	-25.7	1.55 V	323	6.31	41.99
8	4874.00	36.6 AV	54.0	-17.4	1.55 V	323	-5.39	41.99
9	7311.00	54.9 PK	74.0	-19.1	1.32 V	156	8.37	46.53
10	7311.00	42.9 AV	54.0	-11.1	1.32 V	156	-3.63	46.53

REMARKS:

1. Emission Level(dBuV/m) = Raw Value(dBuV) + Correction Factor(dB/m)
2. Correction Factor(dB/m) = Antenna Factor(dB/m) + Cable Factor(dB) – Pre-Amplifier Factor(dB)
3. The other emission levels were very low against the limit.
4. Margin value = Emission Level – Limit value
5. " * ": Fundamental frequency.



A D T

CHANNEL	TX Channel 9	DETECTOR FUNCTION	Peak (PK)
FREQUENCY RANGE	1GHz ~ 25GHz		Average (AV)

ANTENNA POLARITY & TEST DISTANCE: HORIZONTAL AT 3 M

NO.	FREQ. (MHz)	EMISSION LEVEL (dBuV/m)	LIMIT (dBuV/m)	MARGIN (dB)	ANTENNA HEIGHT (m)	TABLE ANGLE (Degree)	RAW VALUE (dBuV)	CORRECTION FACTOR (dB/m)
1	*2452.00	109.4 PK			1.27 H	85	76.85	32.55
2	*2452.00	96.4 AV			1.27 H	85	63.85	32.55
3	2483.50	72.7 PK	74.0	-1.3	1.27 H	85	40.07	32.63
4	2483.50	52.6 AV	54.0	-1.4	1.27 H	85	19.97	32.63
5	4904.00	47.6 PK	74.0	-26.4	1.13 H	153	5.58	42.02
6	4904.00	36.5 AV	54.0	-17.5	1.13 H	153	-5.52	42.02
7	7356.00	54.6 PK	74.0	-19.4	1.00 H	23	7.95	46.65
8	7356.00	42.7 AV	54.0	-11.3	1.00 H	23	-3.95	46.65

ANTENNA POLARITY & TEST DISTANCE: VERTICAL AT 3 M

NO.	FREQ. (MHz)	EMISSION LEVEL (dBuV/m)	LIMIT (dBuV/m)	MARGIN (dB)	ANTENNA HEIGHT (m)	TABLE ANGLE (Degree)	RAW VALUE (dBuV)	CORRECTION FACTOR (dB/m)
1	*2452.00	104.3 PK			1.00 V	176	71.75	32.55
2	*2452.00	92.6 AV			1.00 V	176	60.05	32.55
3	2483.50	64.3 PK	74.0	-9.7	1.00 V	176	31.67	32.63
4	2483.50	46.7 AV	54.0	-7.3	1.00 V	176	14.07	32.63
5	4904.00	47.8 PK	74.0	-26.2	1.53 V	326	5.78	42.02
6	4904.00	36.3 AV	54.0	-17.7	1.53 V	326	-5.72	42.02
7	7356.00	53.6 PK	74.0	-20.4	1.25 V	159	6.95	46.65
8	7356.00	42.1 AV	54.0	-11.9	1.25 V	159	-4.55	46.65

REMARKS:

1. Emission Level(dBuV/m) = Raw Value(dBuV) + Correction Factor(dB/m)
2. Correction Factor(dB/m) = Antenna Factor(dB/m) + Cable Factor(dB) – Pre-Amplifier Factor(dB)
3. The other emission levels were very low against the limit.
4. Margin value = Emission Level – Limit value
5. " * ": Fundamental frequency.

4.3 6dB BANDWIDTH MEASUREMENT

4.3.1 LIMITS OF 6dB BANDWIDTH MEASUREMENT

The minimum of 6dB Bandwidth Measurement is 0.5 MHz.

4.3.2 TEST INSTRUMENTS

DESCRIPTION & MANUFACTURER	MODEL NO.	SERIAL NO.	CALIBRATED DATE	CALIBRATED UNTIL
R&S SPECTRUM ANALYZER	FSP40	100037	Nov. 01, 2012	Oct. 31, 2013

Note:

1. The calibration interval of the above test instruments is 12 months and the calibrations are traceable to NML/ROC and NIST/USA.
2. Tested date : Aug. 29, 2013

4.3.3 TEST PROCEDURE

1. Set resolution bandwidth (RBW) = 100kHz
2. Set the video bandwidth (VBW) $\geq 3 \times$ RBW, Detector = Peak.
3. Trace mode = max hold.
4. Sweep = auto couple.
5. Measure the maximum width of the emission that is constrained by the frequencies associated with the two amplitude points (upper and lower) that are attenuated by 6 dB relative to the maximum level measured in the fundamental emission

4.3.4 DEVIATION FROM TEST STANDARD

No deviation

4.3.5 TEST SETUP

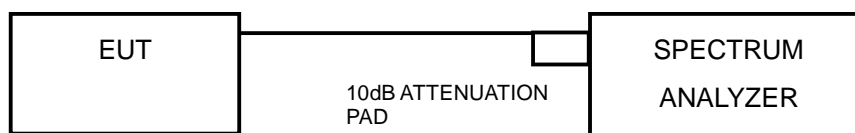

4.3.6 EUT OPERATING CONDITIONS

The software provided by client to enable the EUT under transmission condition continuously at lowest, middle and highest channel frequencies individually.



4.3.7 TEST RESULTS

802.11b

CHANNEL	FREQUENCY (MHz)	6dB BANDWIDTH (MHz)	MINIMUM LIMIT (MHz)	PASS / FAIL
1	2412	12.12	0.5	PASS
6	2437	12.18	0.5	PASS
11	2462	12.16	0.5	PASS

802.11g

CHANNEL	FREQUENCY (MHz)	6dB BANDWIDTH (MHz)	MINIMUM LIMIT (MHz)	PASS / FAIL
1	2412	16.53	0.5	PASS
6	2437	16.58	0.5	PASS
11	2462	16.52	0.5	PASS

802.11n (HT20)

CHANNEL	CHANNEL FREQUENCY (MHz)	6dB BANDWIDTH (MHz)			MINIMUM LIMIT (MHz)	PASS / FAIL
		CHAIN 0	CHAIN 1	CHAIN 2		
1	2412	17.61	17.39	17.37	0.5	PASS
6	2437	17.34	17.62	17.41	0.5	PASS
11	2462	17.41	17.63	17.39	0.5	PASS

802.11n (HT40)

CHANNEL	CHANNEL FREQUENCY (MHz)	6dB BANDWIDTH (MHz)			MINIMUM LIMIT (MHz)	PASS / FAIL
		CHAIN 0	CHAIN 1	CHAIN 2		
3	2422	36.16	36.45	36.09	0.5	PASS
6	2437	36.49	36.48	36.20	0.5	PASS
9	2452	36.19	36.47	36.25	0.5	PASS

4.4 CONDUCTED OUTPUT POWER MEASUREMENT

4.4.1 LIMITS OF CONDUCTED OUTPUT POWER MEASUREMENT

For systems using digital modulation in the 2400–2483.5 MHz bands: 1 Watt (30dBm)

Per KDB 662911 D01 Multiple Transmitter Output v01r02 Method of conducted output power measurement on IEEE 802.11 devices,

Array Gain = 0 dB (i.e., no array gain) for $NANT \leq 4$;

Array Gain = 0 dB (i.e., no array gain) for channel widths ≥ 40 MHz for any NANT;

Array Gain = $5 \log(NANT/NSS)$ dB or 3 dB, whichever is less for 20-MHz channel widths with $NANT \geq 5$.

For power measurements on all other devices: Array Gain = $10 \log(NANT/NSS)$ dB.

4.4.2 INSTRUMENTS

DESCRIPTION & MANUFACTURER	MODEL NO.	SERIAL NO.	CALIBRATED DATE	CALIBRATED UNTIL
Power Meter	ML2495A	0824006	May 10, 2012	May 09, 2013
Peak Power Sensor	MA2411B	0738172	May 10, 2012	May 09, 2013

Note:

1. The calibration interval of the above test instruments is 12 months and the calibrations are traceable to NML/ROC and NIST/USA.
2. Tested date : Nov. 13, 2012

4.4.3 TEST PROCEDURES

The peak power sensor was used on the output port of the EUT. A power meter was used to read the response of the peak power sensor. Record the peak power level.

4.4.4 DEVIATION FROM TEST STANDARD

No deviation

4.4.5 TEST SETUP

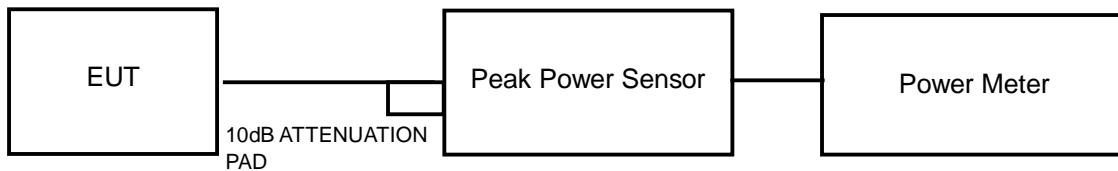

4.4.6 EUT OPERATING CONDITIONS

Same as Item 4.3.6



A D T

4.4.7 TEST RESULTS

802.11b

CHANNEL	FREQUENCY (MHz)	PEAK POWER (mW)	PEAK POWER (dBm)	LIMIT (dBm)	PASS/FAIL
1	2412	173.780	22.4	30	PASS
6	2437	177.828	22.5	30	PASS
11	2462	169.824	22.3	30	PASS

802.11g

CHANNEL	FREQUENCY (MHz)	PEAK POWER (mW)	PEAK POWER (dBm)	LIMIT (dBm)	PASS/FAIL
1	2412	338.844	25.3	30	PASS
6	2437	426.580	26.3	30	PASS
11	2462	478.630	26.8	30	PASS

802.11n (HT20)

CHAN.	CHAN. FREQ. (MHz)	PEAK POWER (dBm)			TOTAL POWER (mW)	TOTAL POWER (dBm)	LIMIT (dBm)	PASS / FAIL
		CHAIN 0	CHAIN 1	CHAIN 2				
1	2412	24.40	24.10	24.50	814.301	29.11	30	PASS
6	2437	24.90	23.80	24.00	800.102	29.03	30	PASS
11	2462	24.20	24.80	24.60	853.425	29.31	30	PASS

802.11n (HT40)

CHAN.	CHAN. FREQ. (MHz)	PEAK POWER (dBm)			TOTAL POWER (mW)	TOTAL POWER (dBm)	LIMIT (dBm)	PASS / FAIL
		CHAIN 0	CHAIN 1	CHAIN 2				
3	2422	19.80	19.80	19.10	272.281	24.35	30	PASS
6	2437	25.30	25.10	24.70	957.559	29.81	30	PASS
9	2452	21.20	21.60	22.10	438.551	26.42	30	PASS

4.5 POWER SPECTRAL DENSITY MEASUREMENT

4.5.1 LIMITS OF POWER SPECTRAL DENSITY MEASUREMENT

The Maximum of Power Spectral Density Measurement is 8dBm.

4.5.2 TEST INSTRUMENTS

DESCRIPTION & MANUFACTURER	MODEL NO.	SERIAL NO.	CALIBRATED DATE	CALIBRATED UNTIL
R&S Spectrum Analyzer	FSP40	100037	Nov. 01, 2012	Oct. 31, 2013

Note:

1. The calibration interval of the above test instruments is 12 months and the calibrations are traceable to NML/ROC and NIST/USA.
2. Tested date : Aug. 29, 2013

4.5.3 TEST PROCEDURE

1. Set the RBW = 3 kHz, VBW =10 kHz, Detector = peak.
2. Sweep time = auto couple, Trace mode = max hold, allow trace to fully stabilize.
3. Use the peak marker function to determine the maximum amplitude level.

4.5.4 DEVIATION FROM TEST STANDARD

No deviation

4.5.5 TEST SETUP

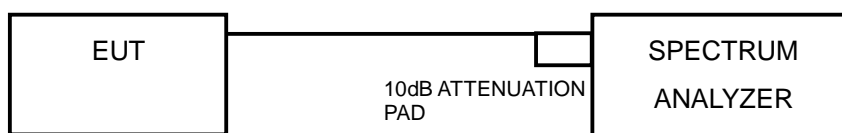

4.5.6 EUT OPERATING CONDITION

Same as Item 4.3.6



A D T

4.5.7 TEST RESULTS

802.11b

CHANNEL	FREQUENCY (MHz)	PSD (dBm/3kHz)	LIMIT (dBm/3kHz)	PASS /FAIL
1	2412	-4.96	8	PASS
6	2437	-4.44	8	PASS
11	2462	-5.63	8	PASS

802.11g

CHANNEL	FREQUENCY (MHz)	PSD (dBm/3kHz)	LIMIT (dBm/3kHz)	PASS /FAIL
1	2412	-11.52	8	PASS
6	2437	-10.17	8	PASS
11	2462	-8.88	8	PASS

802.11n (HT20)

TX chain	Channel	FREQ. (MHz)	PSD (dBm/3kHz)	10 log (N=3) dB	Total PSD (dBm/3kHz)	Limit (dBm/3kHz)	PASS /FAIL
0	1	2412	-12.08	4.77	-7.31	5.17	PASS
	6	2437	-10.89	4.77	-6.12	5.17	PASS
	11	2462	-11.20	4.77	-6.43	5.17	PASS
1	1	2412	-11.33	4.77	-6.56	5.17	PASS
	6	2437	-12.77	4.77	-8.00	5.17	PASS
	11	2462	-11.87	4.77	-7.10	5.17	PASS
2	1	2412	-15.88	4.77	-11.11	5.17	PASS
	6	2437	-11.92	4.77	-7.15	5.17	PASS
	11	2462	-11.18	4.77	-6.41	5.17	PASS



A D T

802.11n (HT40)

TX chain	Channel	FREQ. (MHz)	PSD (dBm/3kHz)	10 log (N=3) dB	Total PSD (dBm/3kHz)	Limit (dBm/3kHz)	PASS /FAIL
0	3	2422	-16.87	4.77	-12.10	5.17	PASS
	6	2437	-12.00	4.77	-7.23	5.17	PASS
	9	2452	-15.61	4.77	-10.84	5.17	PASS
1	3	2422	-17.68	4.77	-12.91	5.17	PASS
	6	2437	-11.56	4.77	-6.79	5.17	PASS
	9	2452	-15.46	4.77	-10.69	5.17	PASS
2	3	2422	-17.88	4.77	-13.11	5.17	PASS
	6	2437	-12.99	4.77	-8.22	5.17	PASS
	9	2452	-15.67	4.77	-10.90	5.17	PASS



A D T

4.6 CONDUCTED OUT-BAND EMISSION MEASUREMENT

4.6.1 LIMITS OF CONDUCTED OUT-BAND EMISSION MEASUREMENT

Below 20dB of the highest emission level of operating band (in 100kHz Resolution Bandwidth).

4.6.2 TEST INSTRUMENTS

DESCRIPTION & MANUFACTURER	MODEL NO.	SERIAL NO.	CALIBRATED DATE	CALIBRATED UNTIL
R&S Spectrum Analyzer	FSP40	100037	Nov. 01, 2012	Oct. 31, 2013

Note:

1. The calibration interval of the above test instruments is 12 months and the calibrations are traceable to NML/ROC and NIST/USA.
2. Tested date : Aug. 23, 2013

4.6.3 TEST PROCEDURE

Measurement Procedure - Reference Level

1. Set the RBW = 100 kHz.
2. Set the VBW \geq 300 kHz.
3. Detector = peak.
4. Sweep time = auto couple.
5. Trace mode = max hold.
6. Allow trace to fully stabilize.
7. Use the peak marker function to determine the maximum power level in any 100 kHz band segment within the fundamental EBW.

Measurement Procedure –Unwanted Emission Level

1. Set RBW = 100 kHz.
2. Set VBW \geq 300 kHz.
3. Set span to encompass the spectrum to be examined
4. Detector = peak.
5. Trace Mode = max hold.
6. Sweep = auto couple.

4.6.4 DEVIATION FROM TEST STANDARD

No deviation

4.6.5 TEST SETUP

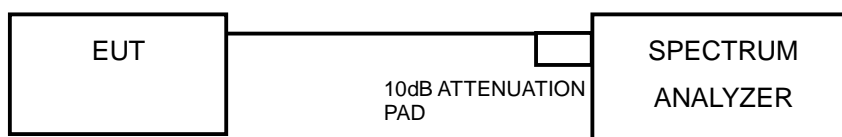

4.6.6 EUT OPERATING CONDITION

Same as Item 4.3.6

4.6.7 TEST RESULTS

The spectrum plots are attached on the following pages. D1 line indicates the highest level, and D2 line indicates the 20dB offset below D1. It shows compliance with the requirement.



A D T

802.11b

CH 1

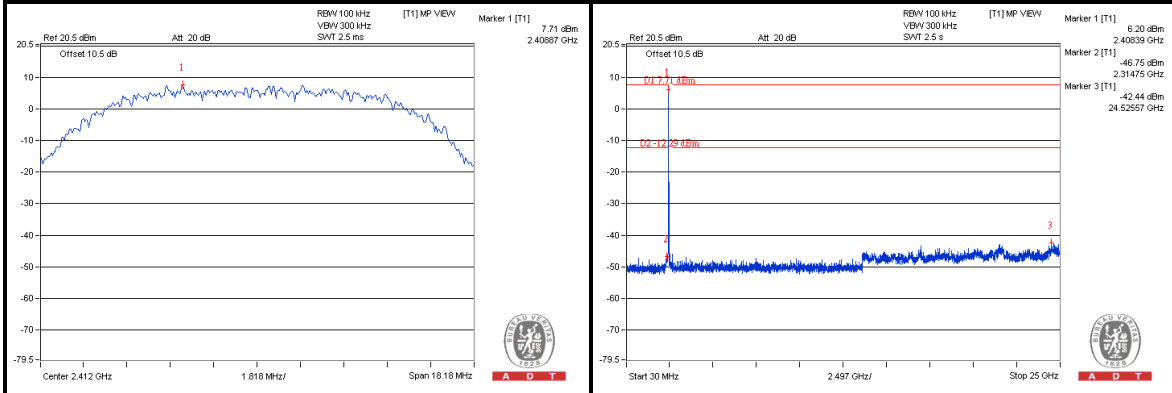

CH 6

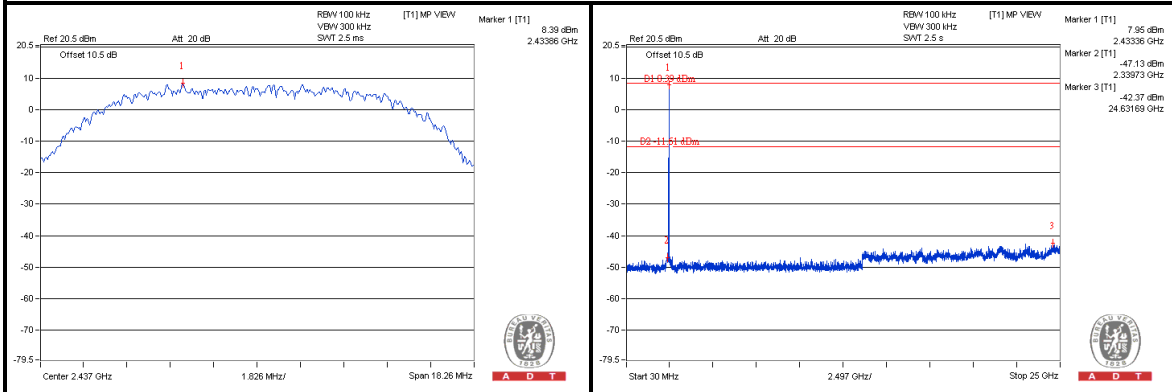

CH 11

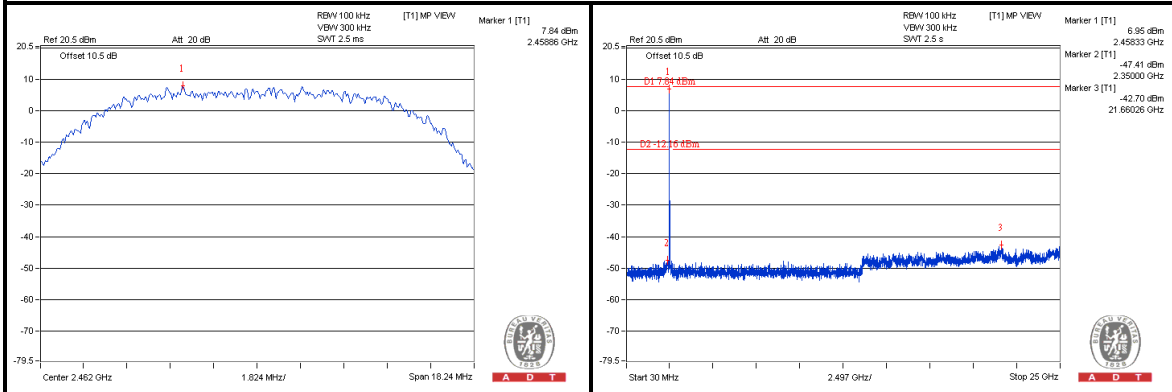



A D T

802.11g

CH 1

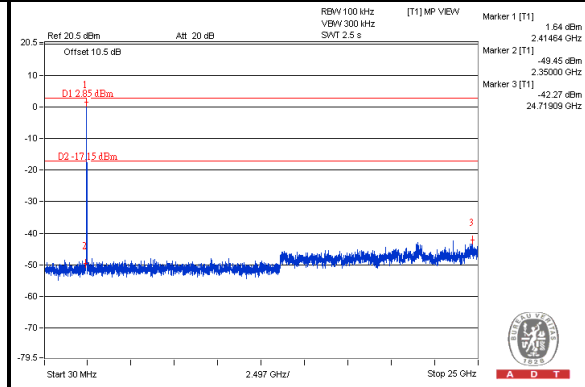
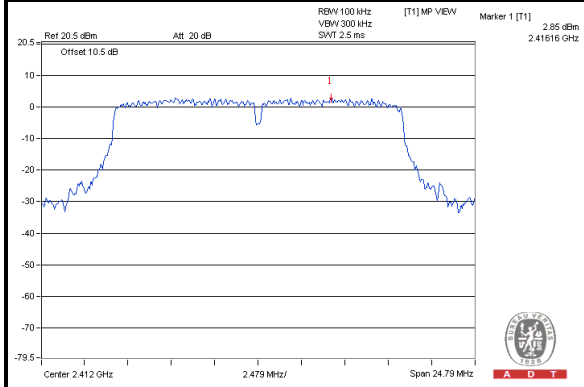

CH 6

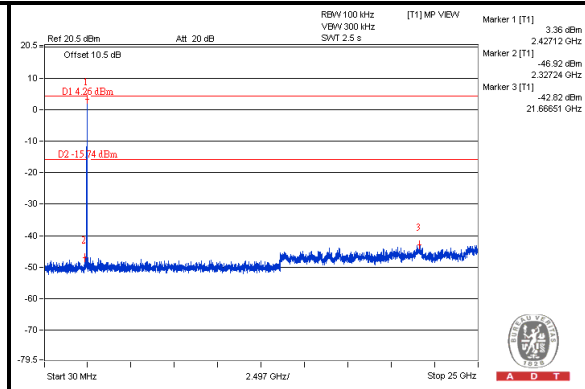
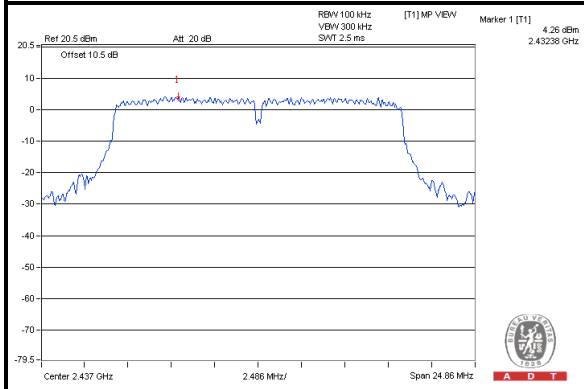

CH 11

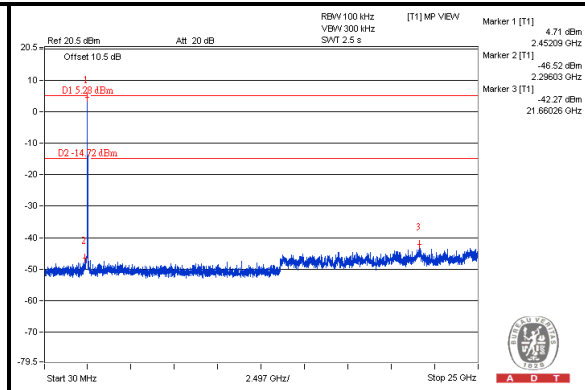
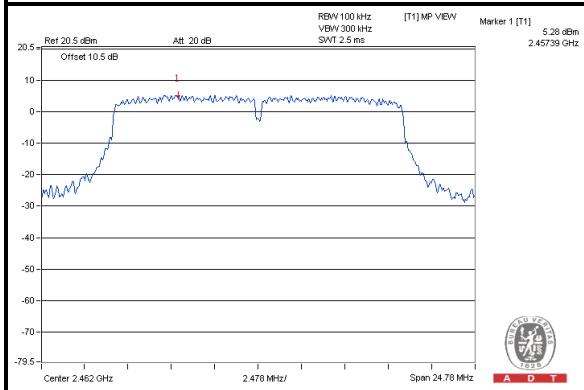



A D T

802.11n (HT20)

Chain 0

CH 1

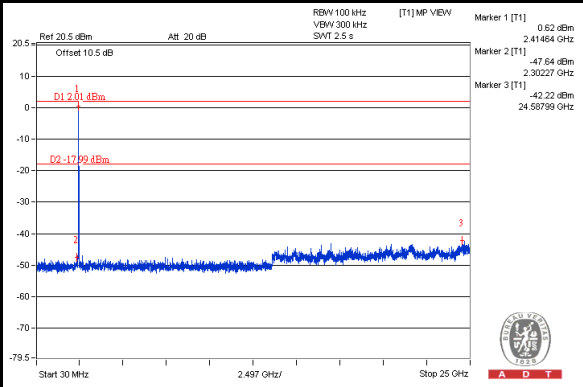
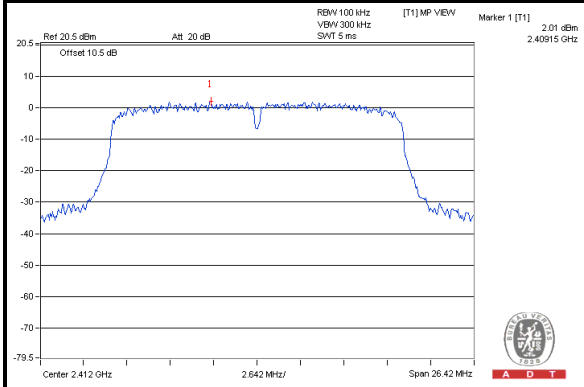

CH 6

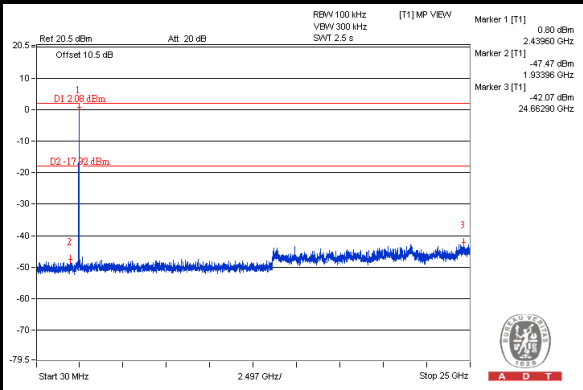
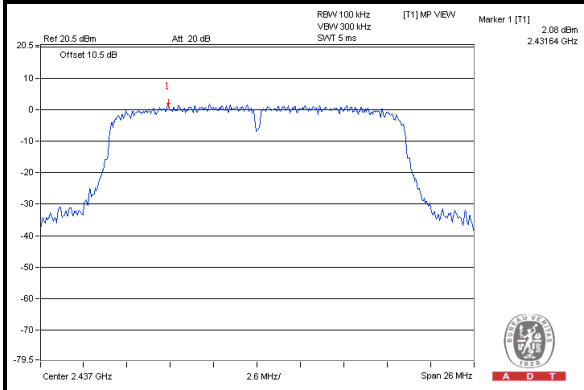

CH 11

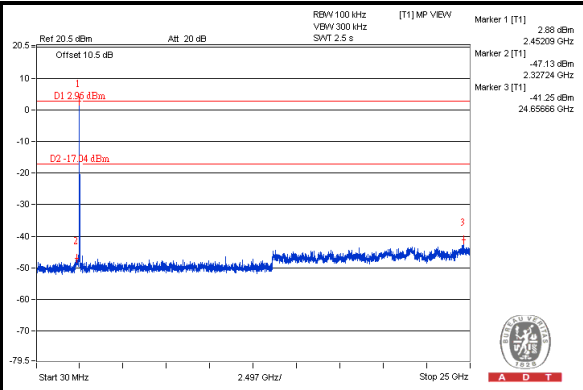
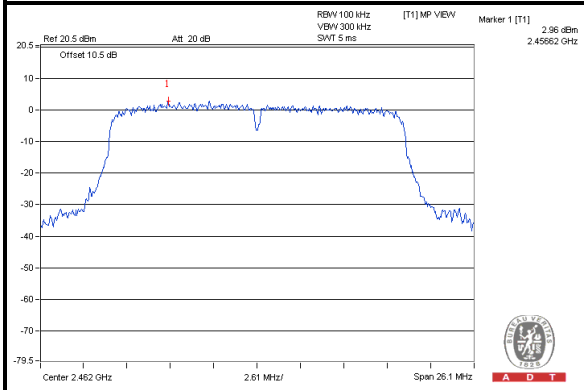



A D T

Chain 1

CH 1

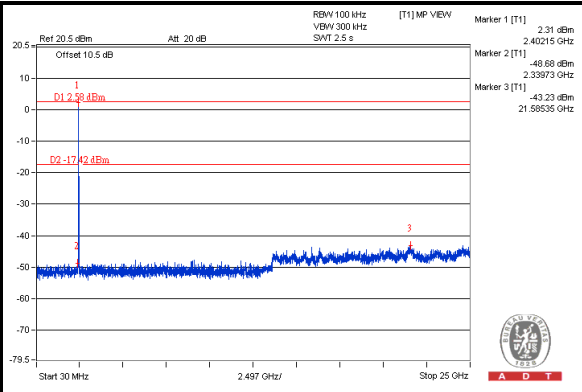
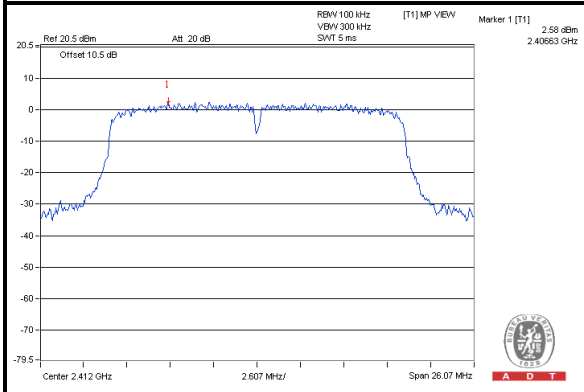

CH 6

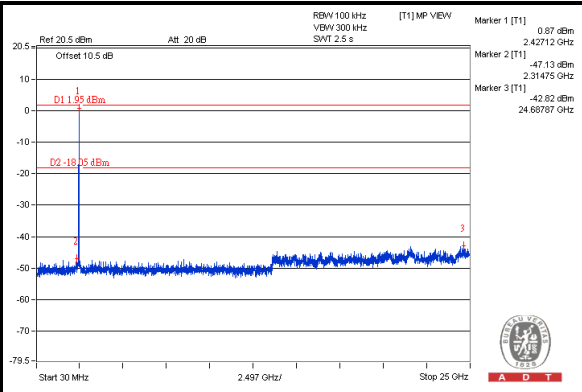
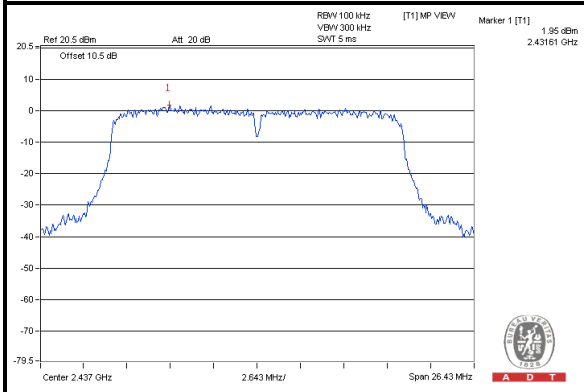

CH 11

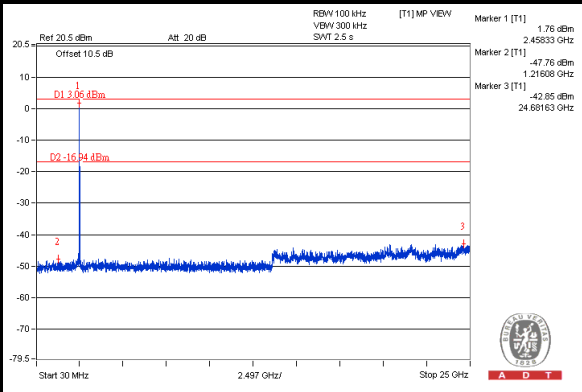
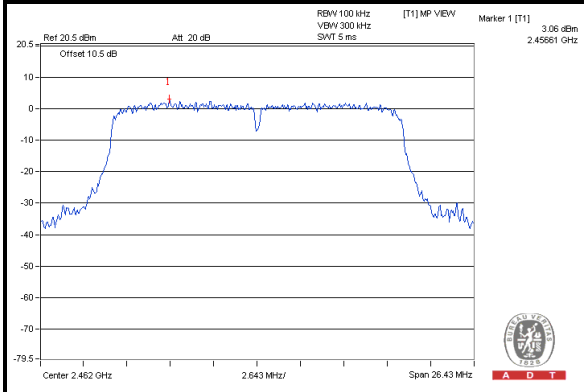



A D T

Chain 2

CH 1

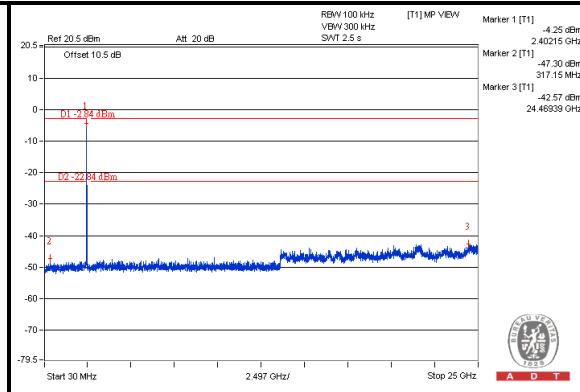
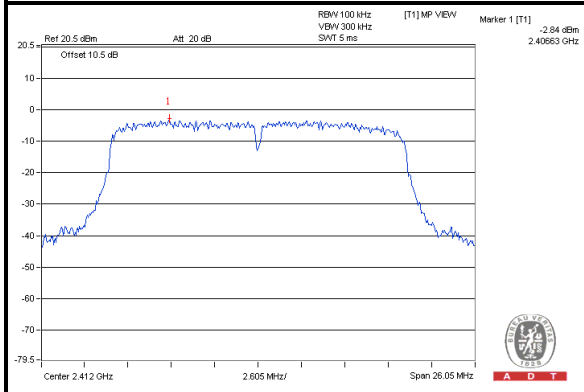

CH 6

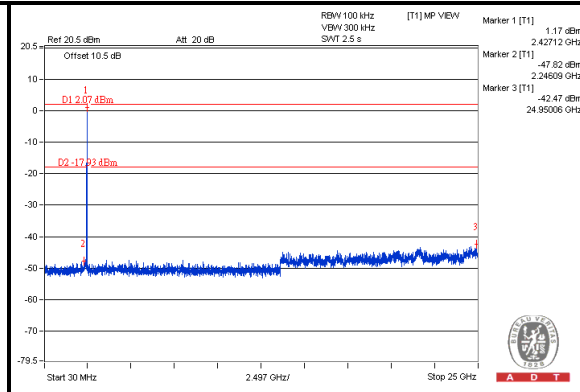
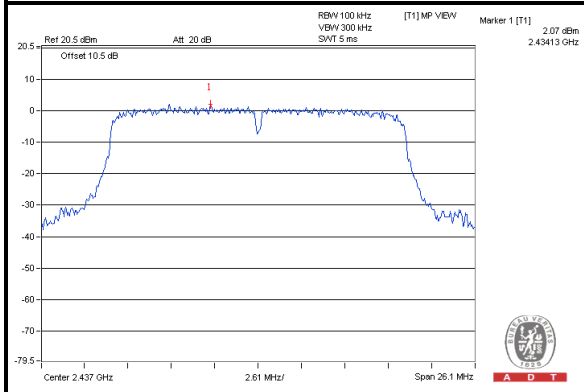

CH 11

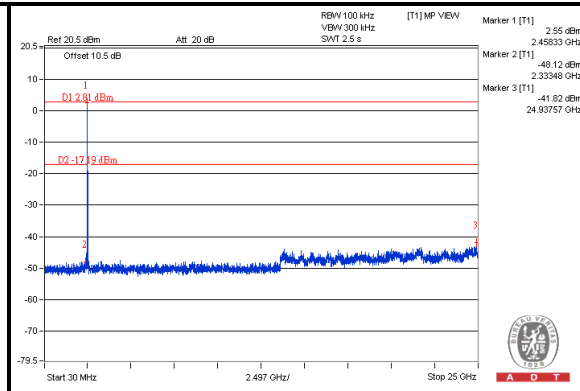
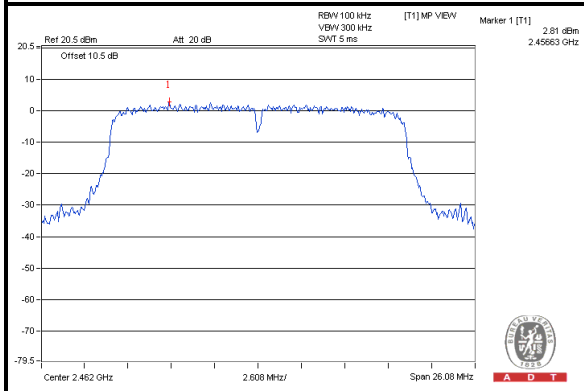



A D T

802.11n (HT40)

Chain 0

CH 3

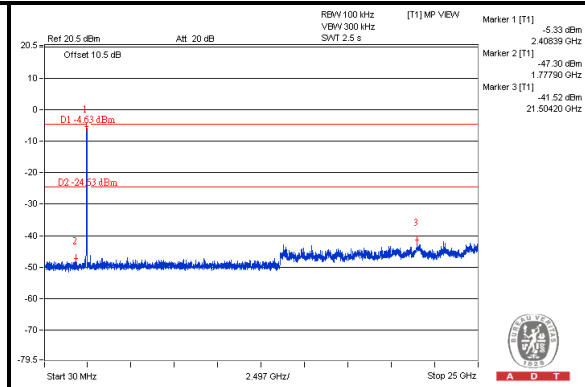
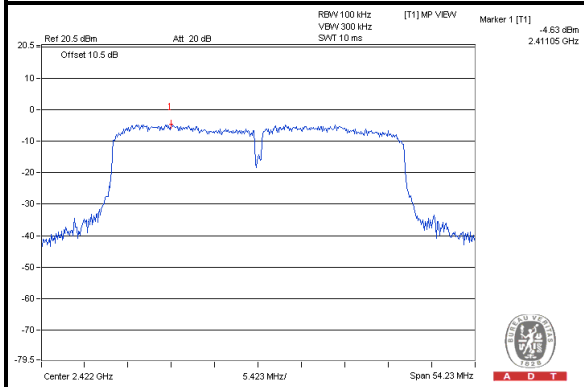

CH 6

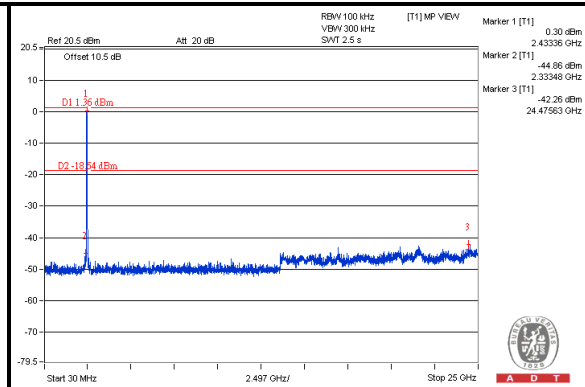
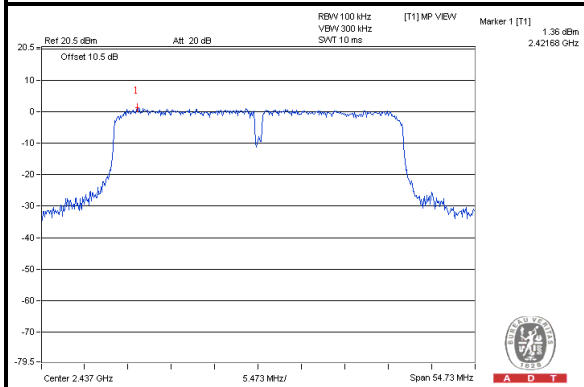

CH 9

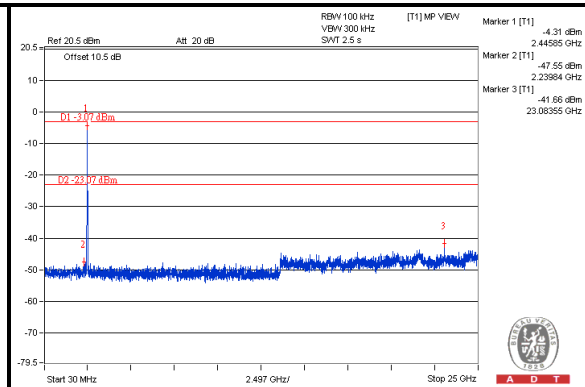
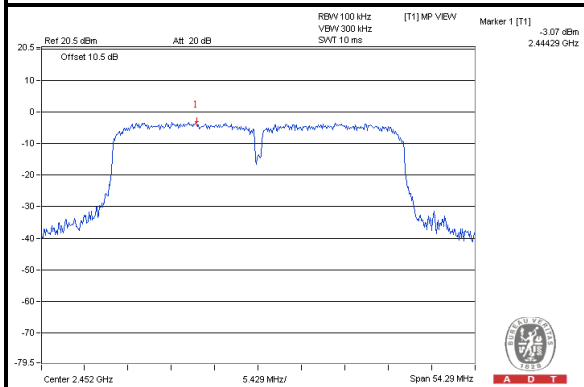



A D T

Chain 1

CH 3

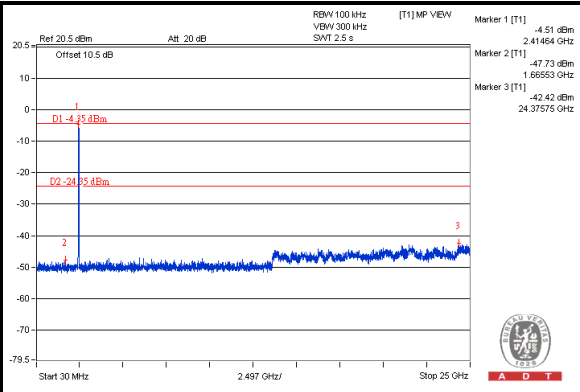
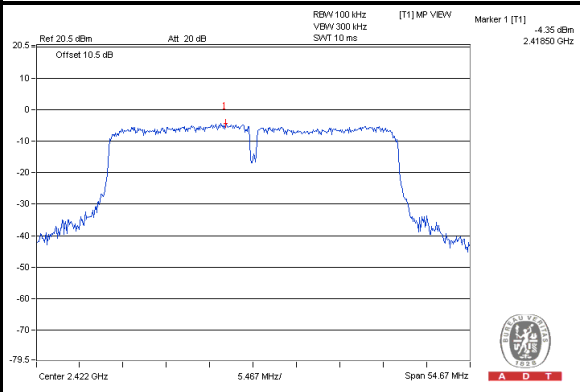

CH 6

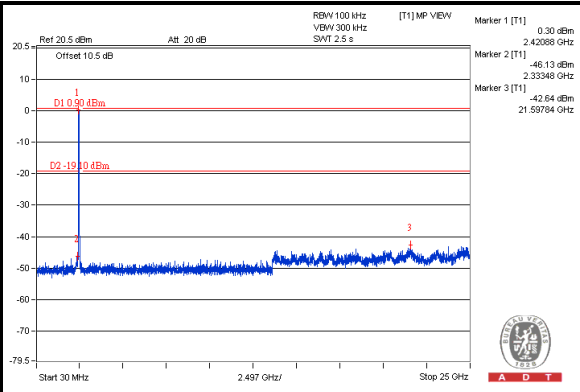
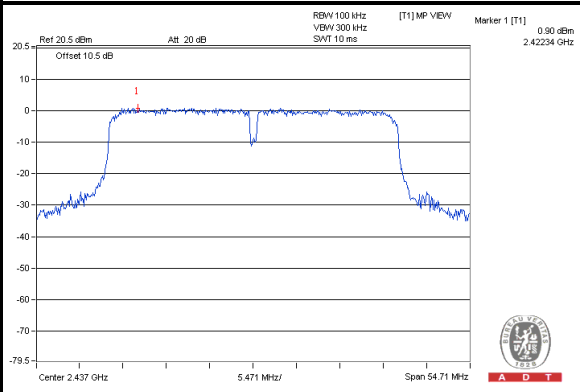

CH 9

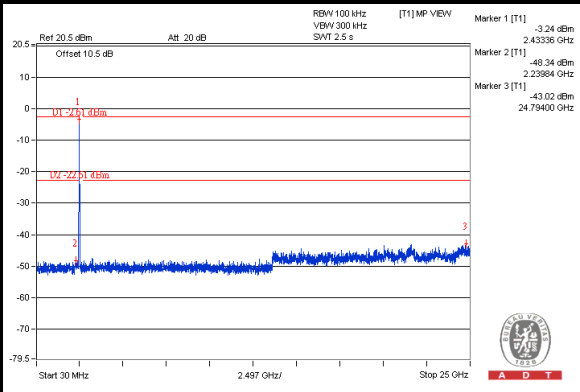
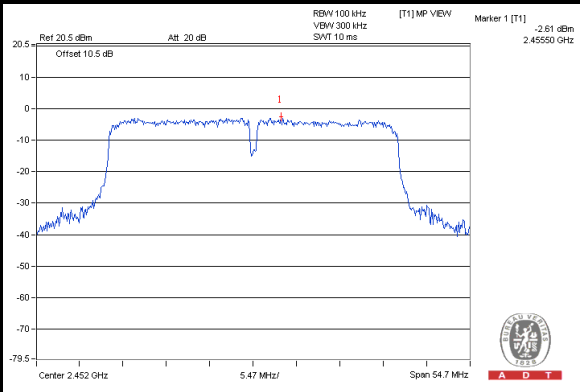



A D T

Chain 2

CH 3

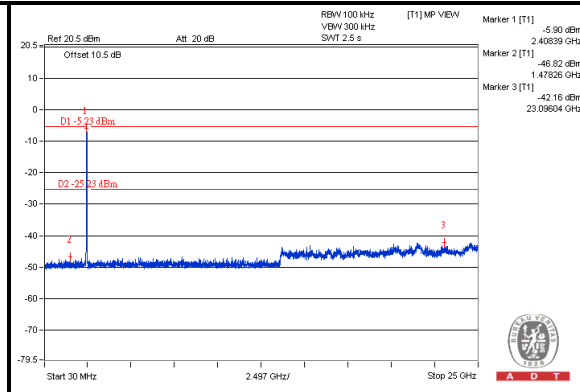
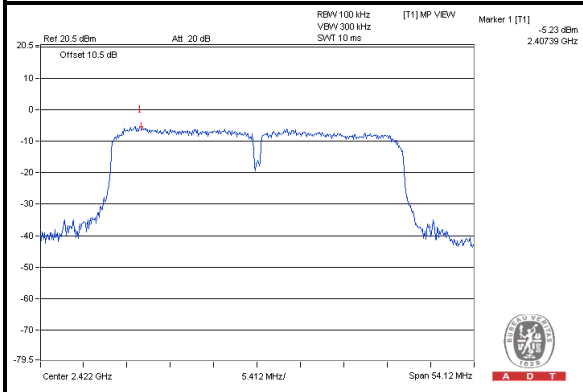

CH 6

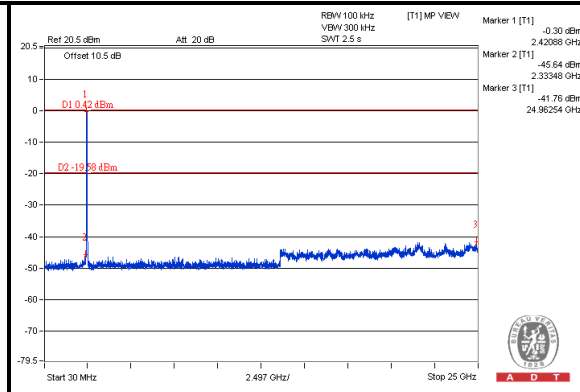
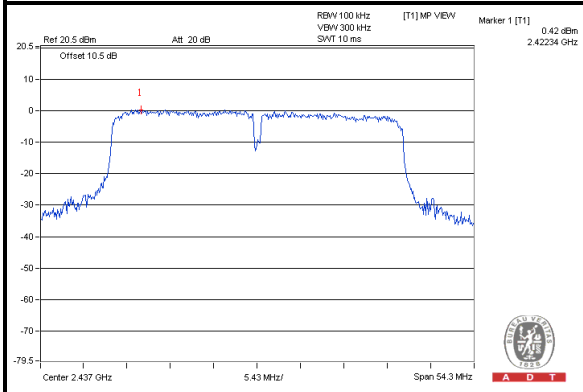

CH 9

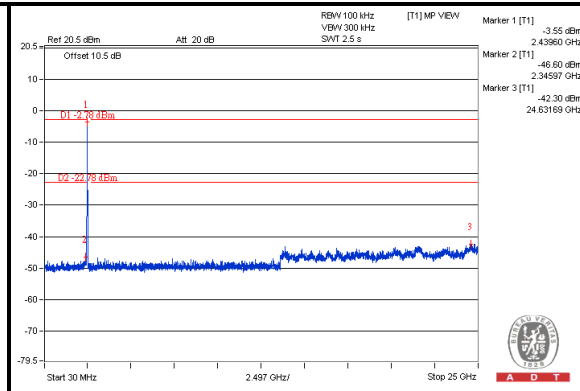
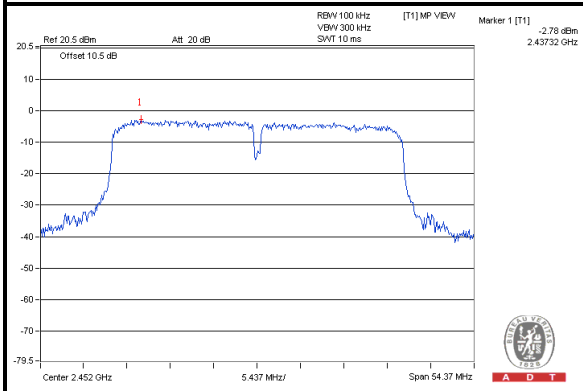



A D T

5. PHOTOGRAPHS OF THE TEST CONFIGURATION

Please refer to the attached file (Test Setup Photo).



6. INFORMATION ON THE TESTING LABORATORIES

We, Bureau Veritas Consumer Products Services (H.K.) Ltd., Taoyuan Branch, were founded in 1988 to provide our best service in EMC, Radio, Telecom and Safety consultation. Our laboratories are accredited and approved according to ISO/IEC 17025.

If you have any comments, please feel free to contact us at the following:

Linko EMC/RF Lab:

Tel: 886-2-26052180

Fax: 886-2-26052943

Hsin Chu EMC/RF Lab:

Tel: 886-3-5935343

Fax: 886-3-5935342

Hwa Ya EMC/RF/Safety/Telecom Lab:

Tel: 886-3-3183232

Fax: 886-3-3270892

Email: service.adt@tw.bureauveritas.com

Web Site: www.bureauveritas-adt.com

The address and road map of all our labs can be found in our web site also.



A D T

7. APPENDIX A - MODIFICATIONS RECORDERS FOR ENGINEERING CHANGES TO THE EUT BY THE LAB

No modifications were made to the EUT by the lab during the test.

--- END ---