



FCC 47 CFR PART 15 SUBPART C AND ANSI C63.4:2003 TEST REPORT

For

8x4 D3 Wireless Router

Model : CGN2-XXXXXXXX

(Where XXXXXXXX = any alpha character "a" - "z", "A" - "Z", or numeric character "0" - "9", or combination of alpha and numeric characters.)

Trade Name : Hitron

Issued for

Hitron Technologies, Inc.

**No. 1-8, Lihsin 1st Rd., HsinChu Science Park,
HishChu, Taiwan 300, R.O.C.**

Issued by

**Compliance Certification Services Inc.
Hsinchu Lab.**

**NO. 989-1 Wen Shan Rd., Shang Shan Village,
Qionglin Shiang Hsinchu County 30741, Taiwan, R.O.C
TEL: +886-3-5921698
FAX: +886-3-5921108**

**http://www.ccsrf.com
E-Mail : service@ccsrf.com**

Issued Date: November 30, 2011



Note: This report shall not be reproduced except in full, without the written approval of Compliance Certification Services Inc. This document may be altered or revised by Compliance Certification Services Inc. personnel only, and shall be noted in the revision section of the document. The client should not use it to claim product endorsement by TAF or any government agencies. The test results of this report relate only to the tested sample identified in this report.



Revision History

Rev.	Issue Date	Revisions	Effect Page	Revised By
00	11/30/2011	Initial Issue	All Page 121	Cindy Pon



TABLE OF CONTENTS

TITLE	PAGE NO.
1. TEST REPORT CERTIFICATION	4
2. EUT DESCRIPTION	5-6
3. DESCRIPTION OF TEST MODES	7
4. TEST METHODOLOGY	8
5. FACILITIES AND ACCREDITATION	8
5.1 FACILITIES	8
5.2 ACCREDITATIONS.....	8
5.3 MEASUREMENT UNCERTAINTY	9
6. SETUP OF EQUIPMENT UNDER TEST.....	10-11
7. FCC PART 15.247 REQUIREMENTS	12
7.1 6dB BANDWIDTH	12-25
7.2 MAXIMUM PEAK OUTPUT POWER	26-40
7.3 AVERAGE POWER	41-43
7.4 POWER SPECTRAL DENSITY	44-58
7.5 CONDUCTED SPURIOUS EMISSION	59-77
7.6 RADIATED EMISSION.....	78-110
7.7 CONDUCTED EMISSION.....	111-115
APPENDIX I MAXIMUM PERMISSIBLE EXPOSURE	116-117
APPENDIX II SETUP PHOTOS	118-121



1. TEST REPORT CERTIFICATION

Applicant : Hitron Technologies, Inc.
Address : No. 1-8, Lihsin 1st Rd., HsinChu Science Park,
 HishChu, Taiwan 300, R.O.C.
Equipment Under Test : 8x4 D3 Wireless Router
Model : CGN2-XXXXXXXX
 (Where XXXXXXXX = any alpha character "a" - "z", "A" - "Z", or numeric character "0" - "9", or combination of alpha and numeric characters.)
Trade Name : Hitron
Tested Date : September 08 ~ 21, 2011 ; November 11 ~ 30, 2011

APPLICABLE STANDARD	
Standard	Test Result
FCC Part 15 Subpart C AND ANSI C63.4:2003	PASS

WE HEREBY CERTIFY THAT: The above equipment has been tested by Compliance Certification Services Inc., and found compliance with the requirements set forth in the technical standards mentioned above. The results of testing in this report apply only to the product/system, which was tested. Other similar equipment will not necessarily produce the same results due to production tolerance and measurement uncertainties.

Approved by:

Sb. Lu
Sr. Engineer

Reviewed by:

Gundam Lin
Sr. Engineer



2. EUT DESCRIPTION

Product Name	8x4 D3 Wireless Router
Model Number	CGN2-XXXXXXXX (Where XXXXXXXX = any alpha character "a" - "z", "A" - "Z", or numeric character "0" - "9", or combination of alpha and numeric characters.)
Identify Number	T11111730701
Received Date	September 08, 2011
Frequency Range	IEEE 802.11b/g, 802.11n HT20 : 2412MHz~2462MHz IEEE 802.11n HT40 : 2422MHz~2452MHz
Transmit Power	IEEE 802.11b : 10.19 dBm (0.0104 W) IEEE 802.11g : 13.40 dBm (0.0219 W) IEEE 802.11n HT20 : 15.74 dBm (0.0375 W) IEEE 802.11n HT40 : 17.12 dBm (0.0515 W)
Channel Spacing	IEEE 802.11b/g, 802.11n HT20/HT40 : 5MHz
Channel Number	IEEE 802.11b/g, 802.11n HT20 : 11 Channels IEEE 802.11n HT40 : 7 Channels
Transmit Data Rate	IEEE 802.11b : 11, 5.5, 2, 1 Mbps IEEE 802.11g : 54, 48, 36, 24, 18, 12, 9, 6 Mbps IEEE 802.11n HT20 : 144.44, 130, 117, 115.56, 104, 86.667, 78, 72.2, 65, 58.5, 57.778, 52, 43.333, 39, 28.889, 26, 21.7, 19.5, 14.444, 13, 7.2, 6.5 Mbps IEEE 802.11n HT40 : 300, 270, 243, 240, 216, 180, 162, 150, 135, 121.5, 120, 108, 90, 81, 60, 54, 45, 40.5, 30, 27, 15, 13.5Mbps
Type of Modulation	IEEE 802.11b : DSSS (CCK, DQPSK, DBPSK) IEEE 802.11g : OFDM (64QAM, 16QAM, QPSK, BPSK) IEEE 802.11n HT20/40 : OFDM (64QAM, 16QAM, QPSK, BPSK)
Antenna Type	Antenna 1 (Chain 0) : Printing Antenna x 1, Antenna Gain 4.73 dBi Antenna 2 (Chain 1) : Printing Antenna x 1, Antenna Gain 3.6 dBi
Power Rating	12Vdc
Test Voltage	120Vac, 60Hz
DC Power Cord Type	Non-shielded cable 1.5 m (Non-detachable)
I/O Port	LAN port x 4, Power port x 1, (Coaxial Cable) RF port x 1, USB Port x 1



Power Adapter :

No.	Manufacturer	Model No.	Power Input	Power Output
1	OEM	ADS0271-W 120200	100-240Vac, 50/60Hz, 0.6A	12Vdc, 2.0A

Remark :

1. The sample selected for test was engineering sample that approximated to production product and was provided by manufacturer.
2. For more details, please refer to the User's manual of the EUT.
3. This submittal(s) (test report) is intended for FCC ID: U4P-CGN21A filing to comply with Section 15.207, 15.209 and 15.247 of the FCC Part 15, Subpart C Rules.
4. The model CGN2-ROG01129 was considered the main model for testing.
5. This report is modified from T110908301.



3. DESCRIPTION OF TEST MODES

The EUT is an 802.11n MIMO transceiver in 8x4 D3 Wireless Router form factor. It has two transmitter chains and two receive chains (2 x 2 configurations). 11b/g mode, only Chain 0 transmitter.

Conducted Emission / Radiated Emission Test (Below 1 GHz)

1. The following test modes were scanned during the preliminary test:

No.	Pre-Test Mode
1	Normal Operating

2. After the preliminary scan, the following test mode was found to produce the highest emission level.

Final Test Mode		
Emission	Radiated Emission	Normal Operating
	Conducted Emission	Normal Operating

Remark : Then, the above highest emission mode of the configuration of the EUT and cable was chosen for all final test items.

Conducted / Radiated Emission Test (Above 1 GHz)

IEEE 802.11b, 802.11g, 802.11n HT20 mode

The EUT had been tested under operating condition.

There are three channels have been tested as following :

Channel	Frequency (MHz)
Low	2412
Middle	2437
High	2462

IEEE 802.11b mode : 1Mbps data rate (worst case) were chosen for full testing.

IEEE 802.11g mode : 6Mbps data rate (worst case) were chosen for full testing.

IEEE 802.11n HT20 mode : 6.5Mbps data rate (worst case) were chosen for full testing.

IEEE 802.11n HT40 mode

The EUT had been tested under operating condition.

There are three channels have been tested as following :

Channel	Frequency (MHz)
Low	2422
Middle	2437
High	2452

IEEE 802.11n HT40 mode : 13.5Mbps data rate (worst case) were chosen for full testing.



4. TEST METHODOLOGY

The tests documented in this report were performed in accordance with ANSI C63.4:2003 and FCC CFR 47, 15.207, 15.209 and 15.247.

5. FACILITIES AND ACCREDITATION

5.1 FACILITIES

All measurement facilities used to collect the measurement data are located at

NO. 989-1 Wen Shan Rd., Shang Shan Village,
Qionglin Shiang Hsinchu County 30741, Taiwan, R.O.C

The sites are constructed in conformance with the requirements of ANSI C63.4:2003 and CISPR 22. All receiving equipment conforms to CISPR 16-1-1, CISPR 16-1-2, CISPR 16-1-3, CISPR 16-1-4, CISPR 16-1-5.

5.2 ACCREDITATIONS

Our laboratories are accredited and approved by the following approval agencies according to ISO/IEC 17025.

Taiwan	TAF
---------------	-----

The measuring facility of laboratories has been authorized or registered by the following approval agencies.

Canada	INDUSTRY CANADA
Japan	VCCI
Taiwan	BSMI
USA	FCC MRA

Copies of granted accreditation certificates are available for downloading from our web site, <http://www.ccsrf.com>



5.3 MEASUREMENT UNCERTAINTY

The following table is for the measurement uncertainty, which is calculated as per the document CISPR 16-4-2.

PARAMETER	UNCERTAINTY
Semi Anechoic Chamber (966 Chamber_B) / Radiated Emission, 30 to 1000 MHz	+/- 3.5189
Semi Anechoic Chamber (966 Chamber_B) / Radiated Emission, 1 to 18GHz	+/- 2.5164
Semi Anechoic Chamber (966 Chamber_B) / Radiated Emission, 18 to 26 GHz	+/- 2.4967
Semi Anechoic Chamber (966 Chamber_B) / Radiated Emission, 26 to 40 GHz	+/- 2.7655
Conducted Emission (Mains Terminals), 9kHz to 30MHz	+/- 1.5923

This uncertainty represents an expanded uncertainty expressed at approximately the 95% confidence level using a coverage factor of $k=2$.

Consistent with industry standard (e.g. CISPR 22: 2006, clause 11, Measurement Uncertainty) determining compliance with the limits shall be base on the results of the compliance measurement. Consequently the measure emissions being less than the maximum allowed emission result in this be a compliant test or passing test.

The acceptable measurement uncertainty value without requiring revision of the compliance statement is base on conducted and radiated emissions being less than U_{CISPR} which is 3.6dB and 5.2dB respectively. CCS values (called U_{Lab} in CISPR 16-4-2) is less than U_{CISPR} as shown in the table above. Therefore, MU need not be considered for compliance.



6. SETUP OF EQUIPMENT UNDER TEST

SUPPORT EQUIPMENT

No.	Product	Manufacturer	Model No.	Serial No.	FCC ID
1	Notebook PC	DELL	Latitude D610	CN-0C4708-48643 -625-5565	DoC
2	Notebook PC	Lenovo ideaPad	S10e_4068-RZ1	L3CEV2D	DoC
3	Usb Flash disk	SanDisk	SDCZ6(2.0G)	2048RB	-----
4	Ethernet Switch	ASUS	GX1008B	90-Q872AN1N0NAM A0-88QSA1003522	-----
5	CMTS	ARRIS	C3 CMTS DOCSIS2. OS/N 5157 5186	-----	-----

No.	Signal Cable Description
1	Unshielded RJ-45 cable, 12m x 1
2	Unshielded RJ-45 cable, 1.2 m x 3
3	Shielded coaxial cable, 10m x 1

SETUP DIAGRAM FOR TESTS

EUT & peripherals setup diagram is shown in appendix setup photos.

EUT OPERATING CONDITION

RF Mode

1. Set up all computers like the setup diagram.
2. Telnet 192.168.0.1
Login : cusadmin
Password : password

mainMenu> she
Password: password

Paste→iwpriv ra0 set QAEnable=1
Open QA tool→ Select the computer network card

TX Mode:

- ⇒ **Tx Data Rate:** 1Mbps Bandwidth 20 (IEEE 802.11b mode)
6Mbps Bandwidth 20 (IEEE 802.11g mode)



6.5Mbps Bandwidth 20 (IEEE 802.11n HT20 mode)

13.5Mbps Bandwidth 40 (IEEE 802.11n HT40 mode)

⇒ **Power control**

IEEE 802.11b Channel Low (2412MHz) TX Power0 0B (only chain 0 TX)

IEEE 802.11b Channel Mid (2437MHz) TX Power0 0B(only chain 0 TX)

IEEE 802.11b Channel High (2462MHz) TX Power0 0E (only chain 0 TX)

IEEE 802.11g Channel Low (2412MHz) TX Power0 17 (only chain 0 TX)

IEEE 802.11g Channel Mid (2437MHz) TX Power0 18 (only chain 0 TX)

IEEE 802.11g Channel High (2462MHz) TX Power0 1B (only chain 0 TX)

IEEE 802.11n HT20 Channel Low (2412MHz) TX Power0 16/TX Power1 14

IEEE 802.11n HT20 Channel Mid (2437MHz) TX Power0 18 /TX Power1 15

IEEE 802.11n HT20 Channel High (2462MHz) TX Power0 1B /TX Power1 18

IEEE 802.11n HT40 Channel Low (2422MHz) TX Power0 19 /TX Power1 17

IEEE 802.11n HT40 Channel Mid (2437MHz) TX Power0 1C /TX Power1 19

IEEE 802.11n HT40 Channel High (2452MHz) TX Power0 1C /TX Power1 19

3. All of the functions are under run.

4. Start test.

Normal Mode

1. Setup whole system for test as shown on diagram.

2. Power on all equipments.

3. Coaxial Cable link Headend-CMTS.

CMTS set DOWN STREAM : -10 dBmV, UP STREAM: + 40 dBmV.

4. Notebook PC (2) ping to Notebook PC (1).

5. Notebook PC (1) ping to Notebook PC (2).

6. LAN 2~3 port link ethernet switch load.

7. USB port link USB flash disk load.

8. Start test.



7. FCC PART 15.247 REQUIREMENTS

7.1 6dB BANDWIDTH

LIMITS

§ 15.247(a) (2) For direct sequence systems, the minimum 6dB bandwidth shall be at least 500kHz.

TEST EQUIPMENT

Name of Equipment	Manufacturer	Model	Serial Number	Calibration Due
Spectrum Analyzer	Agilent	E4407B	US41443108	08/09/2012

Remark: Each piece of equipment is scheduled for calibration once a year.

TEST SETUP



TEST PROCEDURE

The transmitter output was connected to a spectrum analyzer. The bandwidth of the fundamental frequency was measured by spectrum analyzer with 100 KHz RBW and 300 KHz VBW. The 6dB bandwidth is defined as the total spectrum the power of which is higher than peak power minus 6dB.



TEST RESULTS

IEEE 802.11b Mode

Channel	Channel Frequency (MHz)	6dB Bandwidth (MHz)	Minimum Limit (kHz)	Pass / Fail
Low	2412	10.00	500	PASS
Middle	2437	12.00	500	PASS
High	2462	10.33	500	PASS

IEEE 802.11g Mode

Channel	Channel Frequency (MHz)	6dB Bandwidth (MHz)	Minimum Limit (kHz)	Pass / Fail
Low	2412	16.42	500	PASS
Middle	2437	16.42	500	PASS
High	2462	16.42	500	PASS

IEEE 802.11n HT20 Mode (Two TX)

Channel	Channel Frequency (MHz)	6dB Bandwidth (MHz)		Minimum Limit (kHz)	Pass / Fail
		Chain 0	Chain 1		
Low	2412	17.08	16.92	500	PASS
Middle	2437	16.92	16.92	500	PASS
High	2462	16.75	17.08	500	PASS

IEEE 802.11n HT40 Mode (Two TX)

Channel	Channel Frequency (MHz)	6dB Bandwidth (MHz)		Minimum Limit (kHz)	Pass / Fail
		Chain 0	Chain 1		
Low	2422	35.58	35.50	500	PASS
Middle	2437	35.58	34.92	500	PASS
High	2452	35.33	35.17	500	PASS



6dB BANDWIDTH

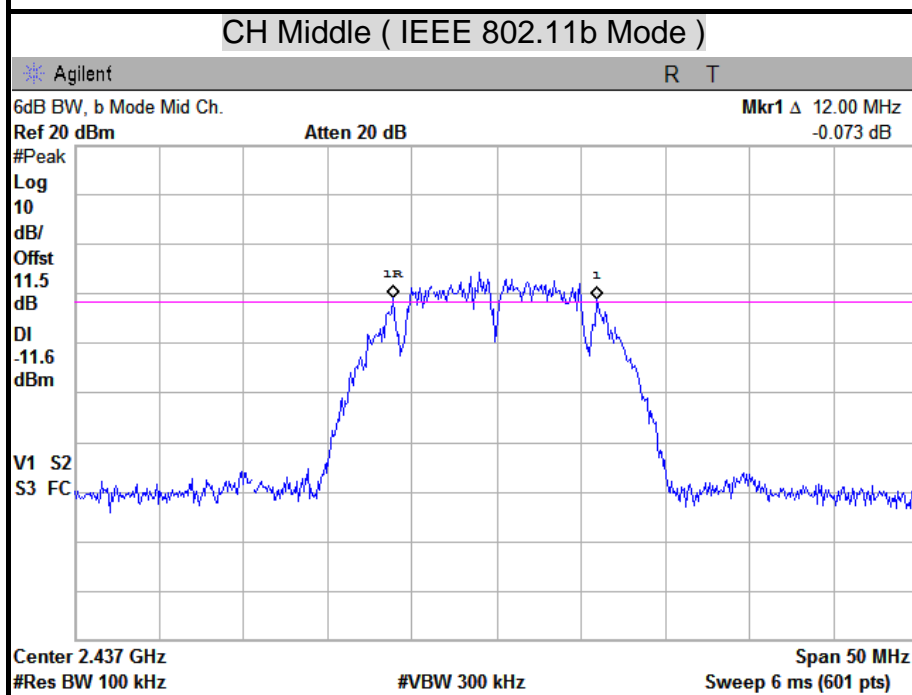
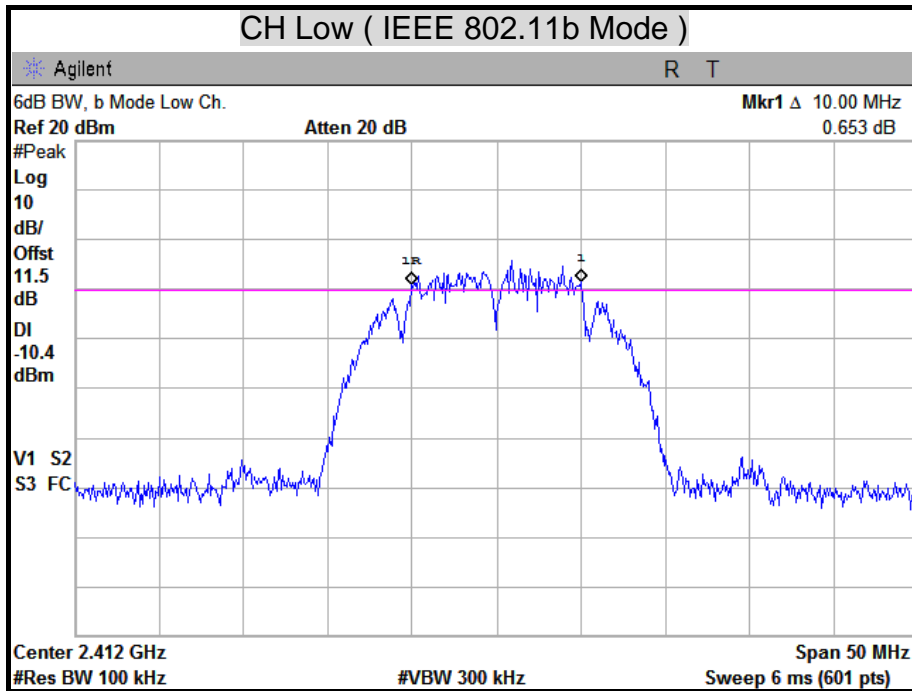

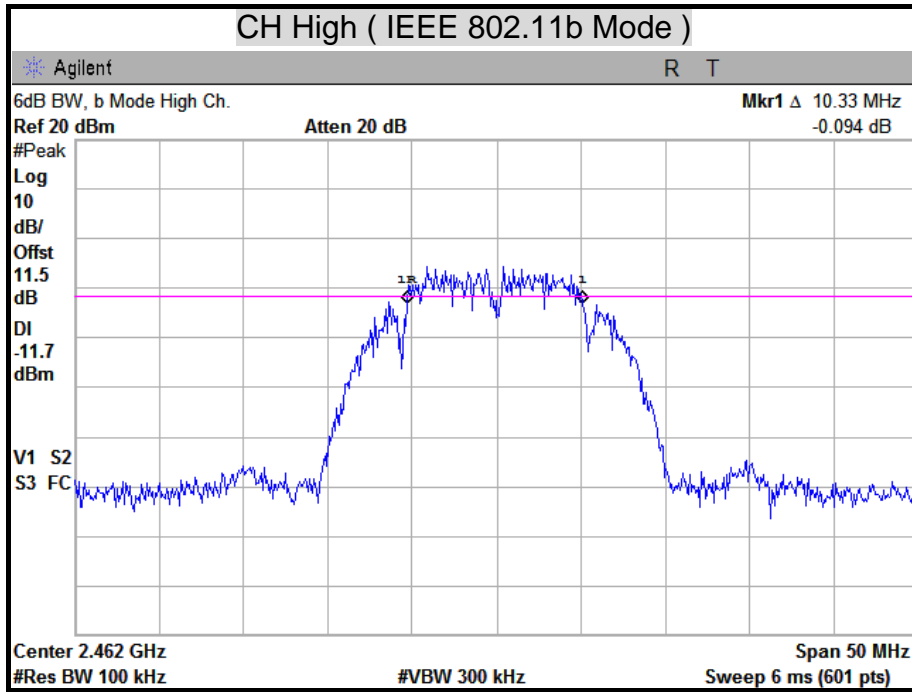

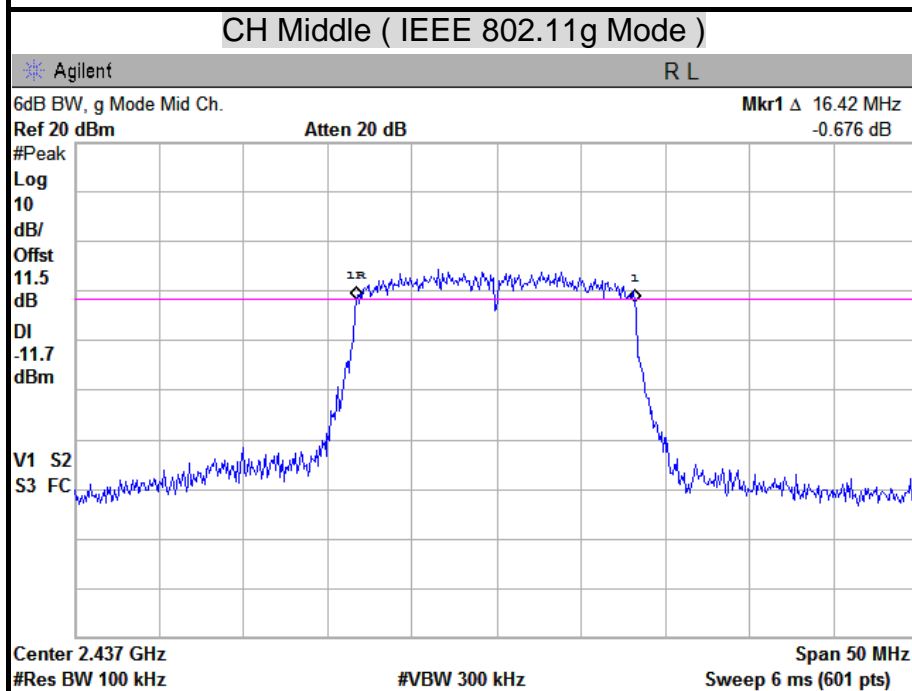
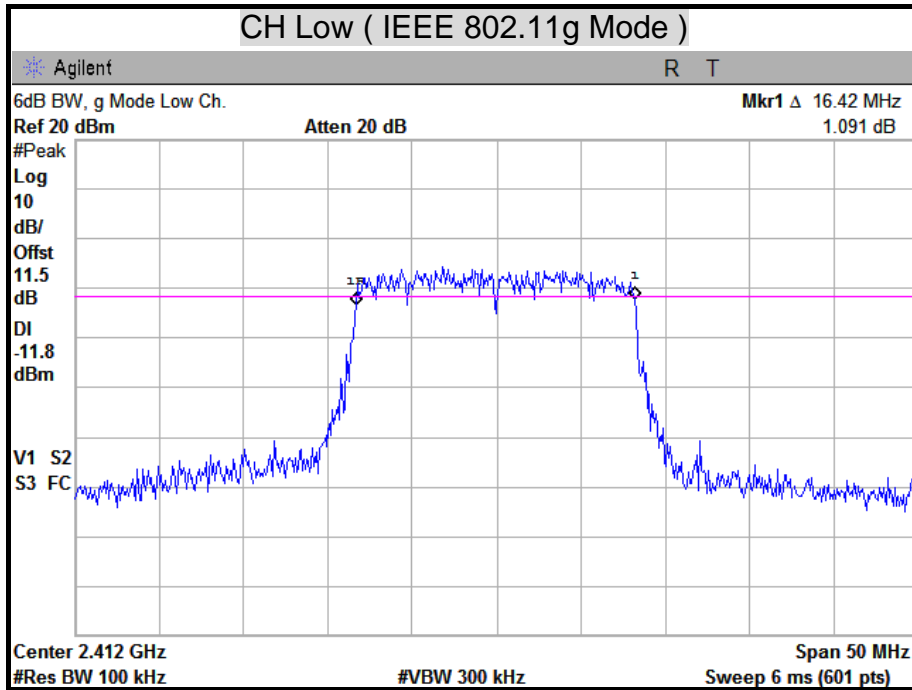

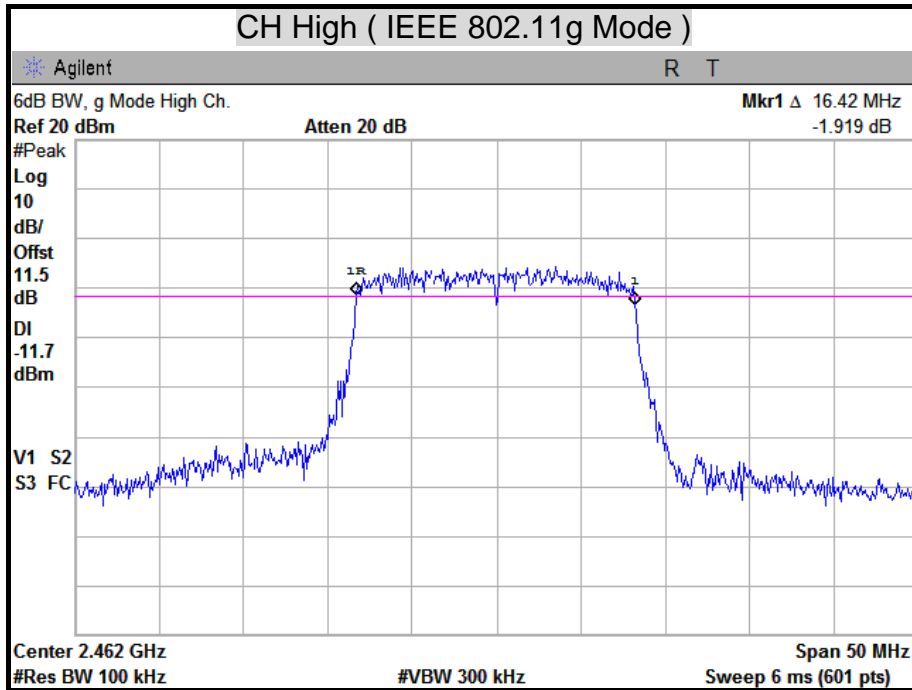

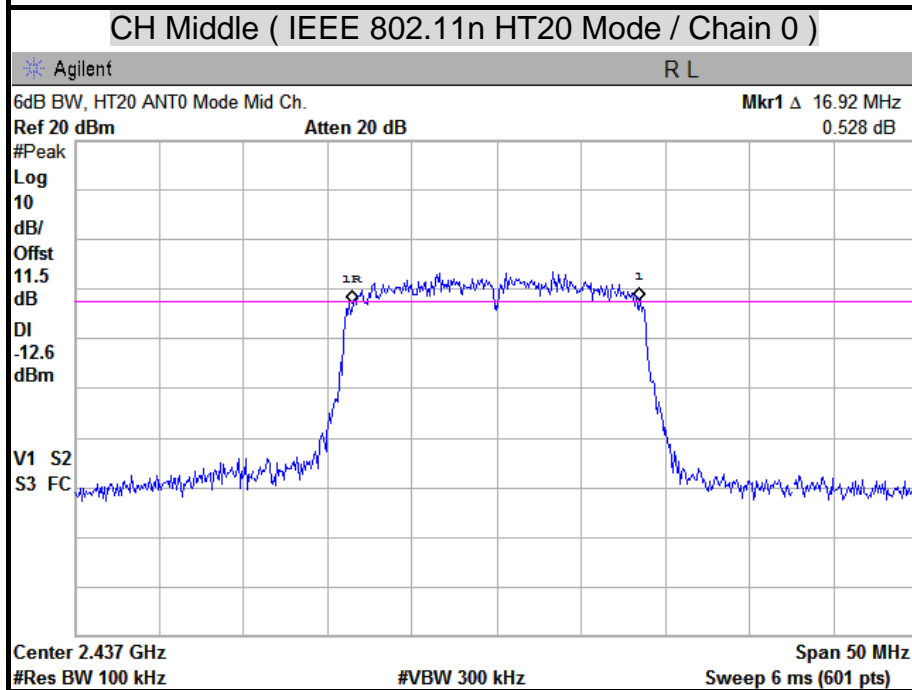
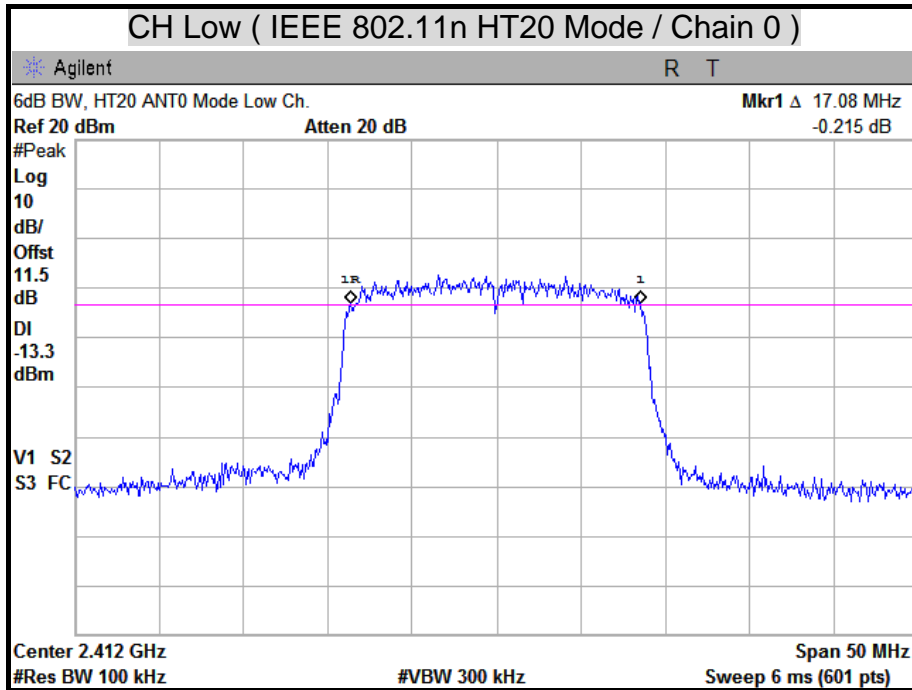

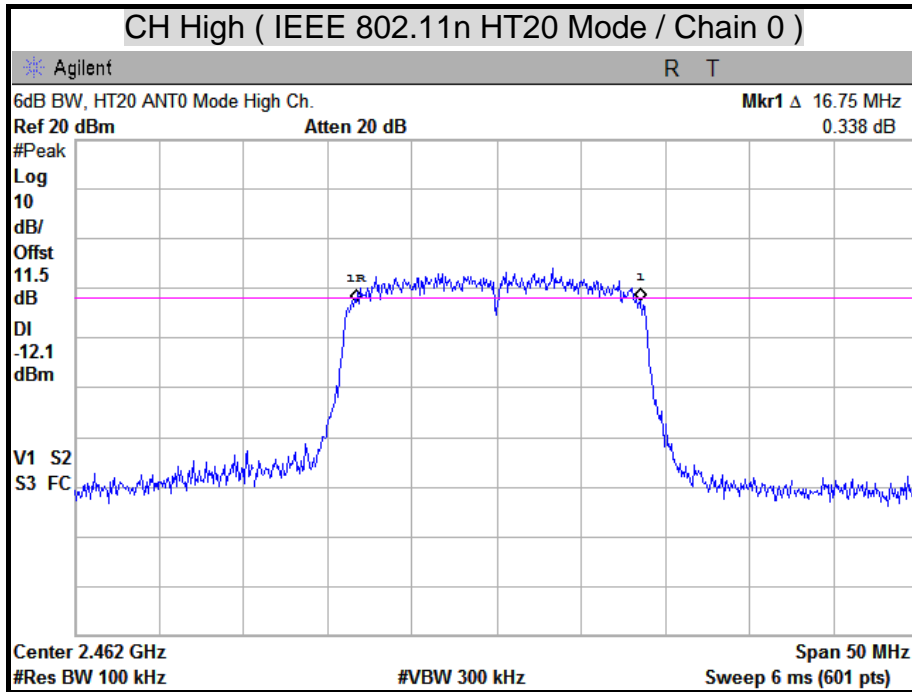

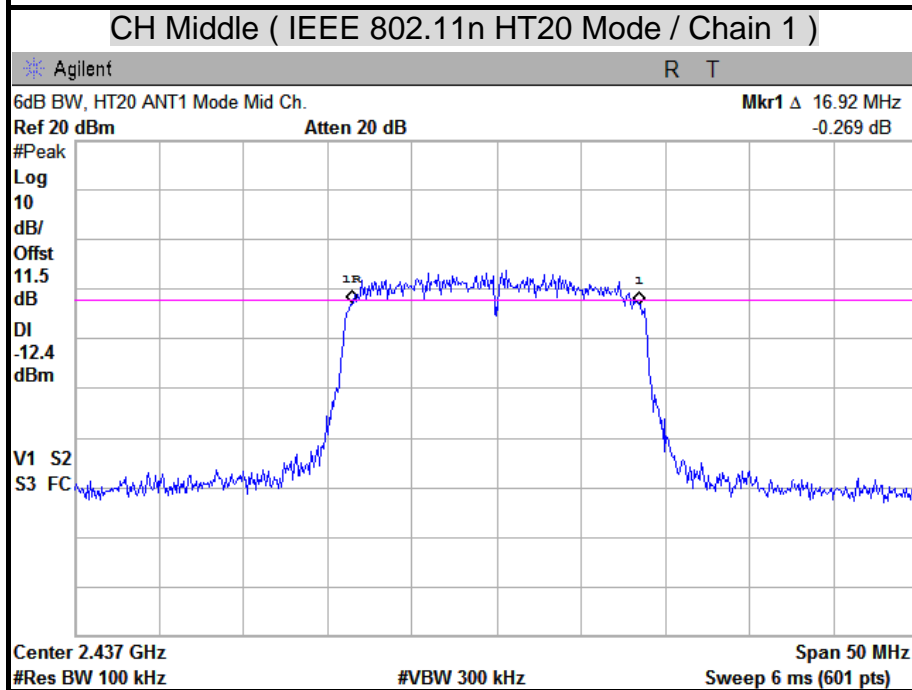
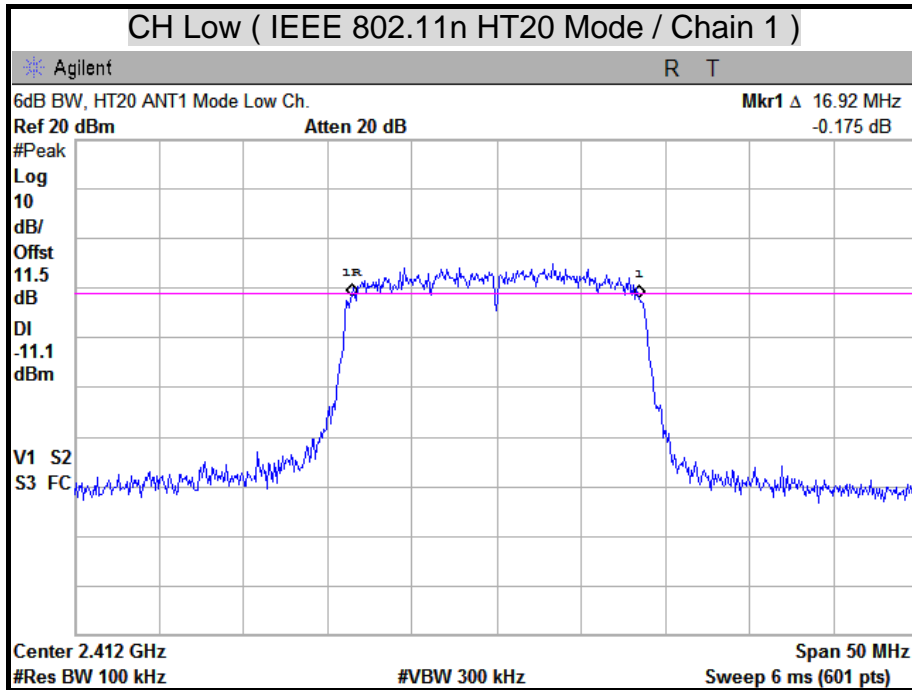

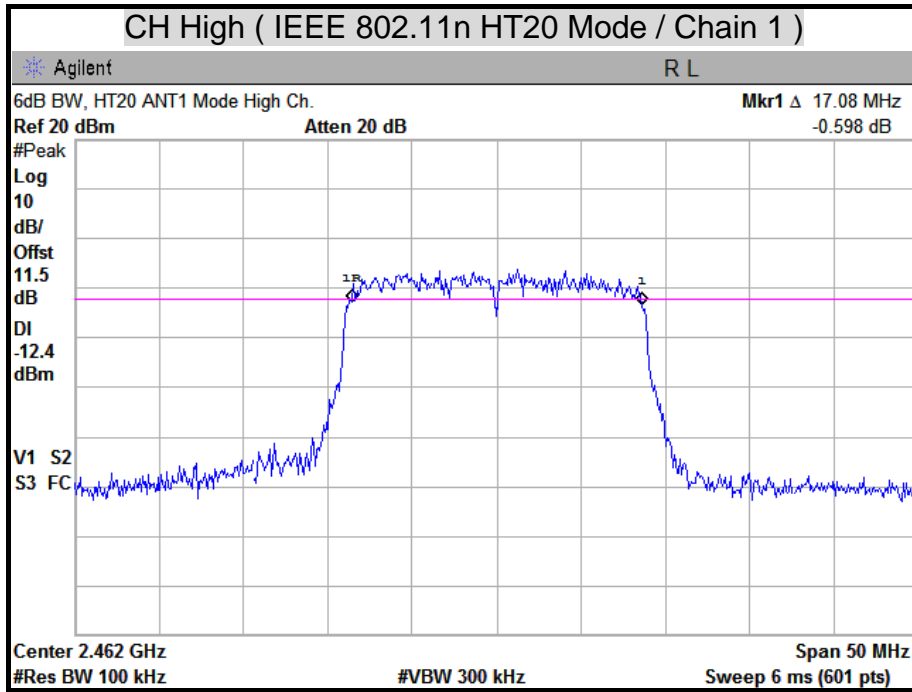

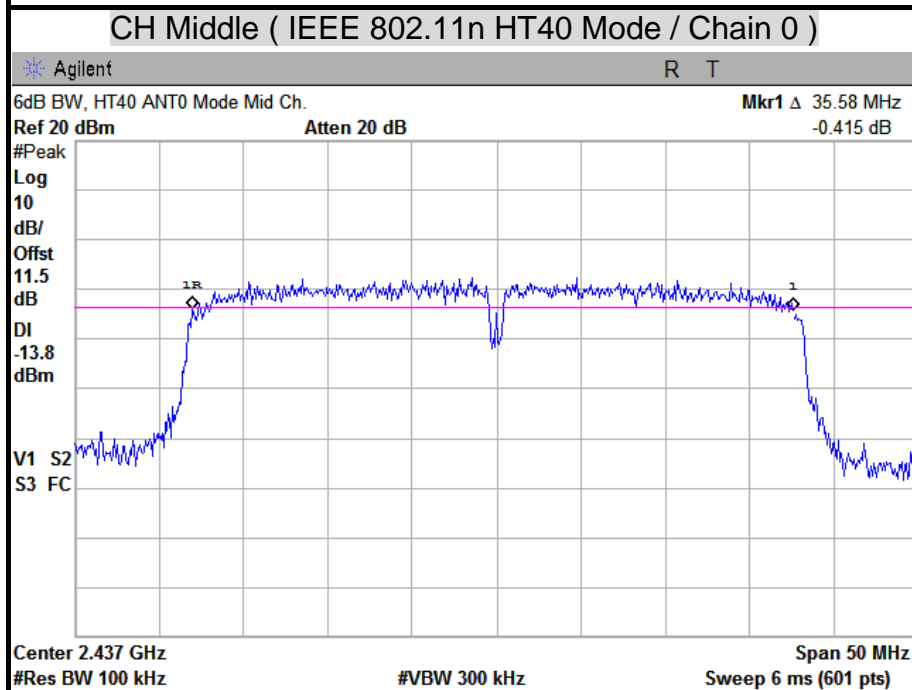
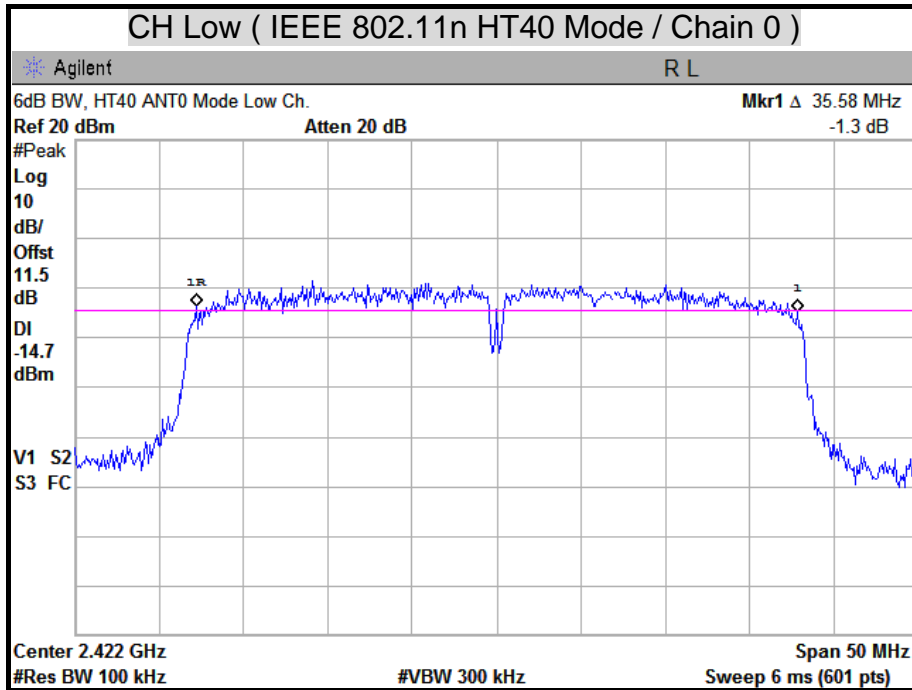

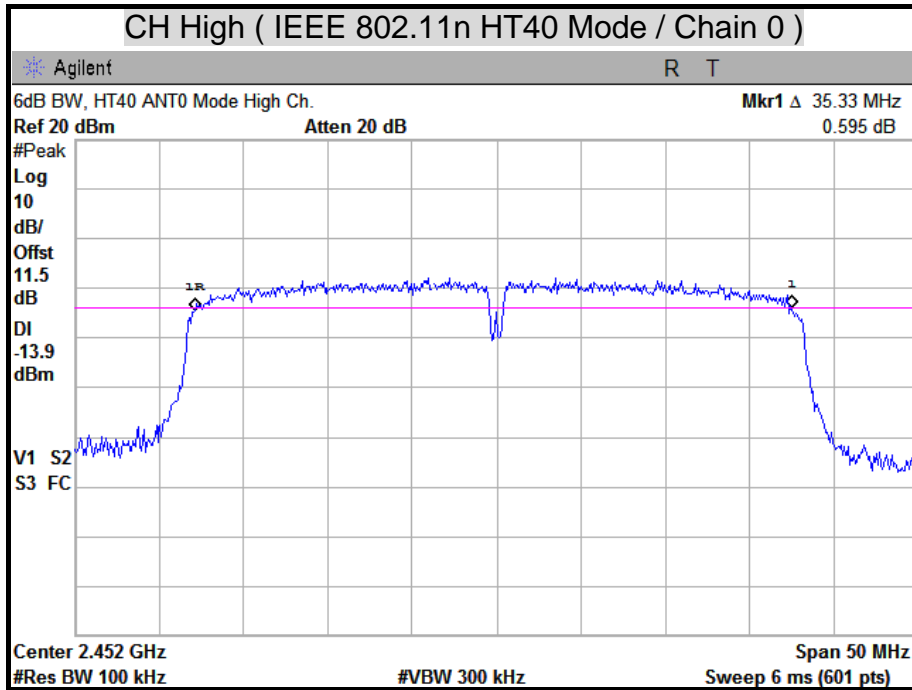

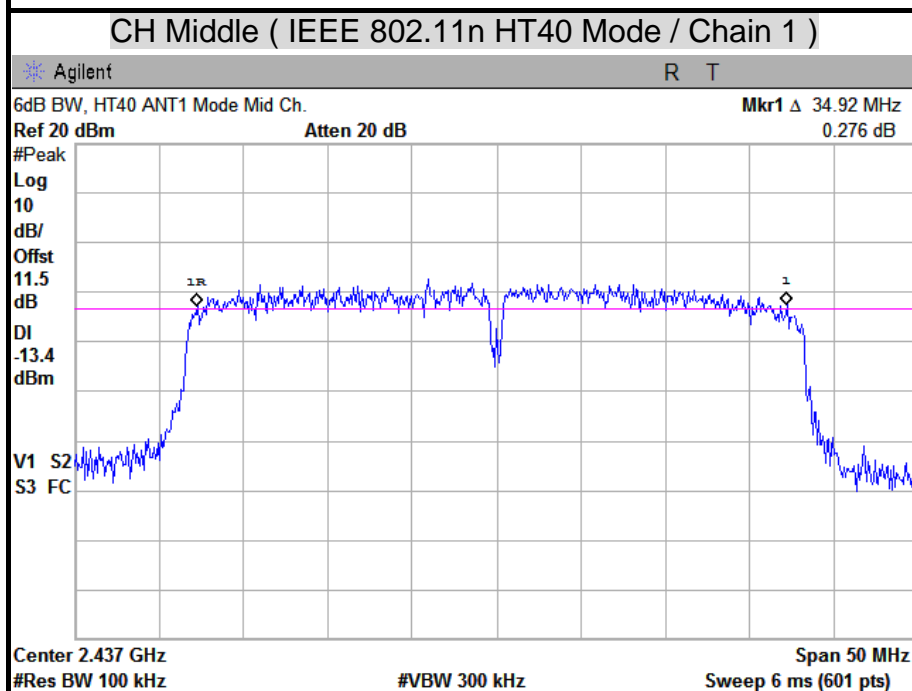
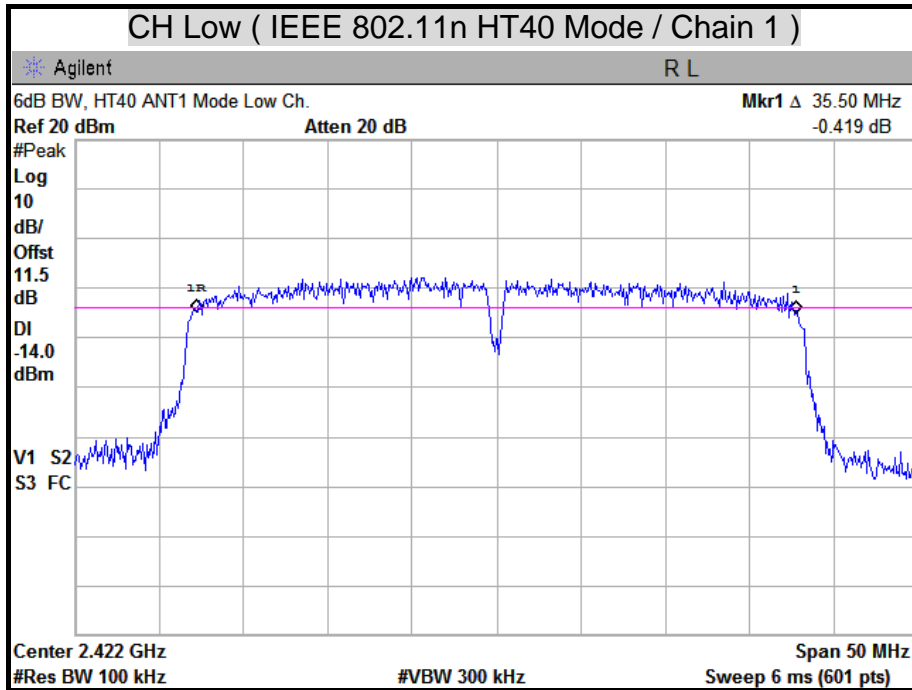

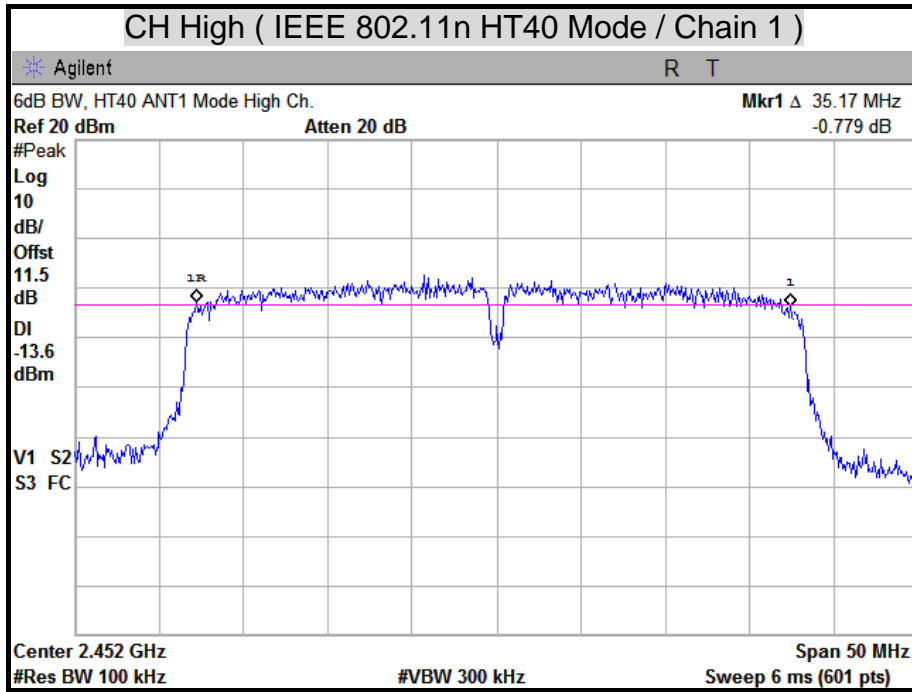



7.2 MAXIMUM PEAK OUTPUT POWER

LIMITS

§ 15.247(b) The maximum peak output power of the intentional radiator shall not exceed the following :

§ 15.247(b) (3) For systems using digital modulation in the 902-928 MHz, 2400-2483.5 MHz, and 5725-5850 MHz bands : 1 watt.

§ 15.247(b) (4) Except as shown in paragraphs (c) of this section, if transmitting antennas of directional gain greater than 6 dBi are used the peak output power from the intentional radiator shall be reduced below the stated values in paragraphs (b)(1) or (b)(2), and (b)(3) of this section, as appropriate, by the amount in dB that the directional gain of the antenna exceeds 6 dBi.

TEST EQUIPMENT

Name of Equipment	Manufacturer	Model	Serial Number	Calibration Due
Spectrum Analyzer	Agilent	E4407B	US41443108	08/09/2012

Remark: Each piece of equipment is scheduled for calibration once a year.

TEST SETUP

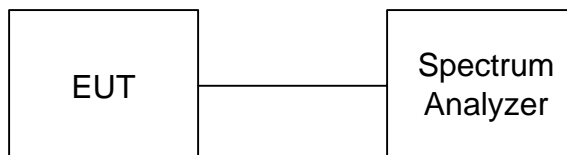

TEST PROCEDURE

- The spectrum shall be set as follows :
Span : 1.5 times channel integration bandwidth.
RBW : 1MHz
VBW : 3MHz
Detector : Peak
Sweep : Single trace
- Compute the combined power of all signal responses contained in the trace by covering all the data points.
- The peak output power is the channel power integrated over 26dB bandwidth.



TEST RESULTS

IEEE 802.11b Mode

Channel	Channel Frequency (MHz)	Peak Power		Peak Power Limit		Pass / Fail
		(dBm)	(W)	(dBm)	(W)	
Low	2412	9.89	0.0097	30	1	PASS
Middle	2437	9.18	0.0083	30	1	PASS
High	2462	10.19	0.0104	30	1	PASS

Remark:

1. At final test to get the worst-case emission at 1Mbps.
2. The cable assembly insertion loss of 11.5 dB (including 10 dB pad and 1.5 dB cable) was Entered as an offset in the spectrum analyzer to allow for direct reading of power.

IEEE 802.11g Mode

Channel	Channel Frequency (MHz)	Peak Power		Peak Power Limit		Pass / Fail
		(dBm)	(W)	(dBm)	(W)	
Low	2412	13.01	0.0200	30	1	PASS
Middle	2437	12.90	0.0195	30	1	PASS
High	2462	13.40	0.0219	30	1	PASS

Remark:

1. At final test to get the worst-case emission at 6Mbps.
2. The cable assembly insertion loss of 11.5 dB (including 10 dB pad and 1.5 dB cable) was Entered as an offset in the spectrum analyzer to allow for direct reading of power.



IEEE 802.11n HT20 Mode (Two TX)

Channel	Channel Frequency (MHz)	Peak Power (dBm)		Peak Power Total		Peak Power Limit		Pass / Fail
		Chain 0	Chain 1	(dBm)	(W)	(dBm)	(W)	
Low	2412	11.71	12.74	15.27	0.0336	28.79	0.7568	PASS
Middle	2437	11.96	12.14	15.06	0.0321	28.79	0.7568	PASS
High	2462	12.41	13.03	15.74	0.0375	28.79	0.7568	PASS

Remark:

1. At final test to get the worst-case emission at 6.5Mbps.
2. The cable assembly insertion loss of 11.5 dB (including 10 dB pad and 1.5 dB cable) was Entered as an offset in the spectrum analyzer to allow for direct reading of power.
3. Total peak power = Chain 0 + Chain 1.
4. The maximum Antenna gain for the MIMO mode is 7.21dBi which is more than 6dBi, the limit should be 0.7568W.

IEEE 802.11n HT40 Mode (Two TX)

Channel	Channel Frequency (MHz)	Peak Power (dBm)		Peak Power Total		Peak Power Limit		Pass / Fail
		Chain 0	Chain 1	(dBm)	(W)	(dBm)	(W)	
Low	2422	13.00	13.80	16.43	0.0439	28.79	0.7568	PASS
Middle	2437	14.06	14.16	17.12	0.0515	28.79	0.7568	PASS
High	2452	13.66	13.51	16.60	0.0457	28.79	0.7568	PASS

Remark:

1. At final test to get the worst-case emission at 13.5Mbps.
2. The cable assembly insertion loss of 11.5 dB (including 10 dB pad and 1.5 dB cable) was Entered as an offset in the spectrum analyzer to allow for direct reading of power.
3. Total peak power = Chain 0 + Chain 1.
4. The maximum Antenna gain for the MIMO mode is 7.21dBi which is more than 6dBi, the limit should be 0.7568W.



MAXIMUM PEAK OUTPUT POWER

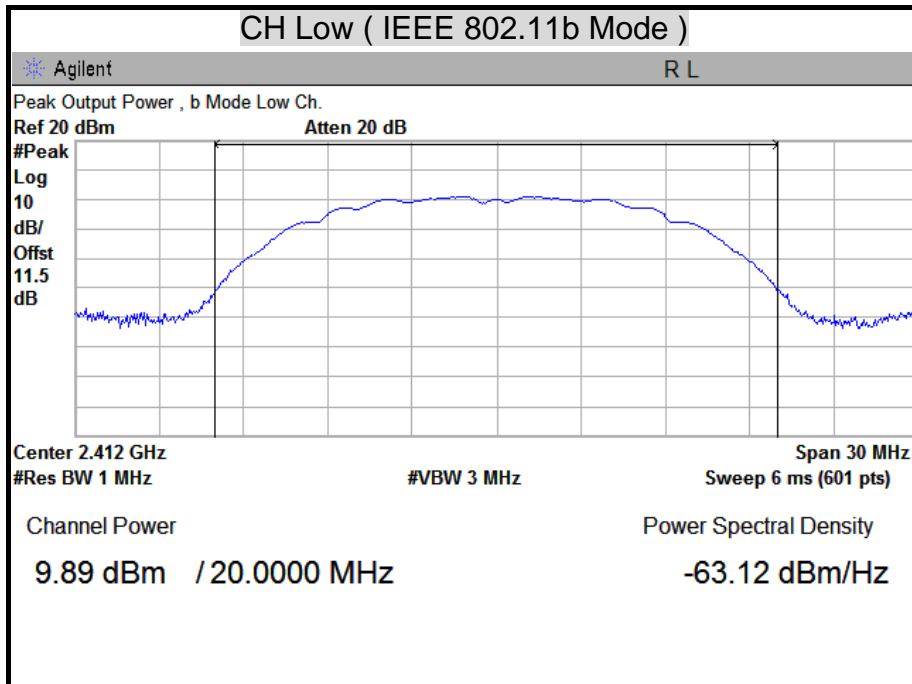

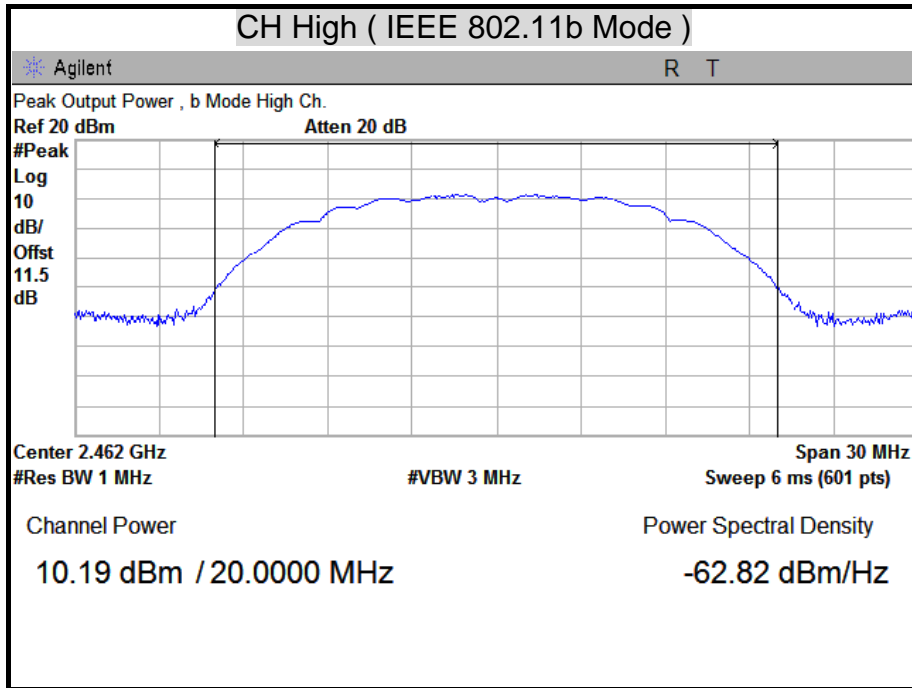

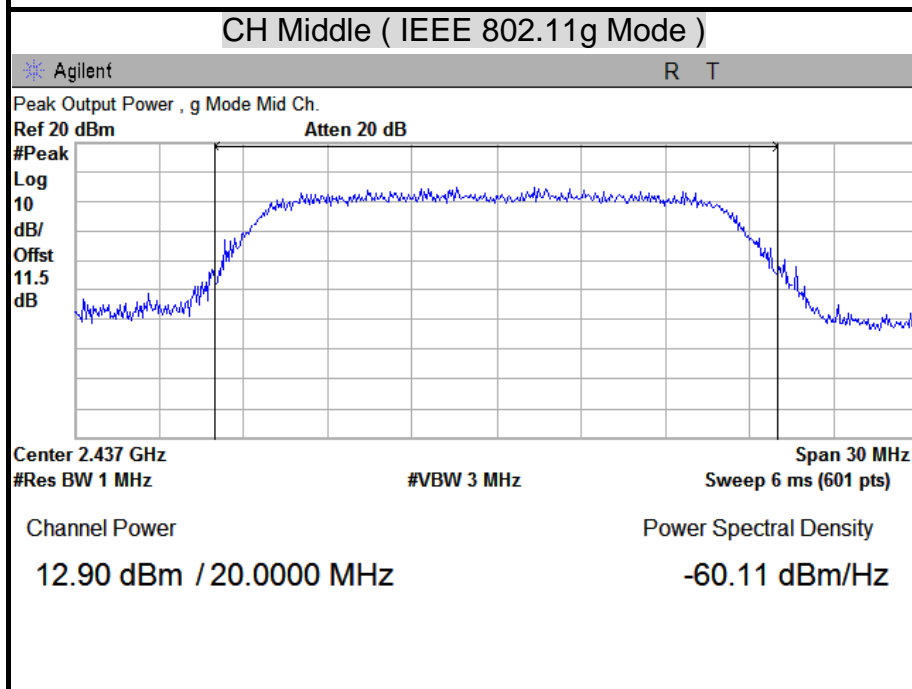
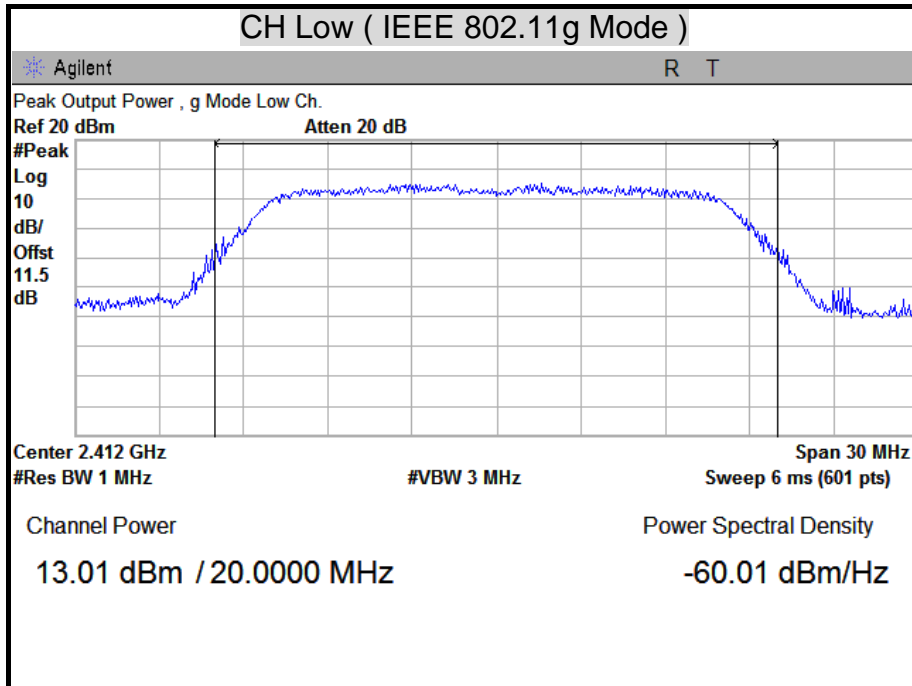

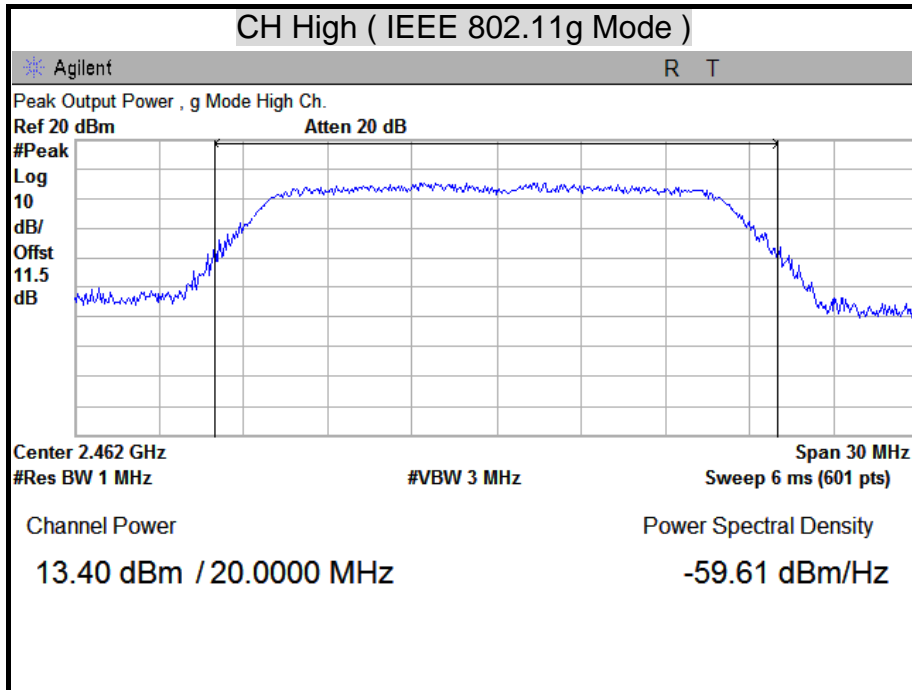

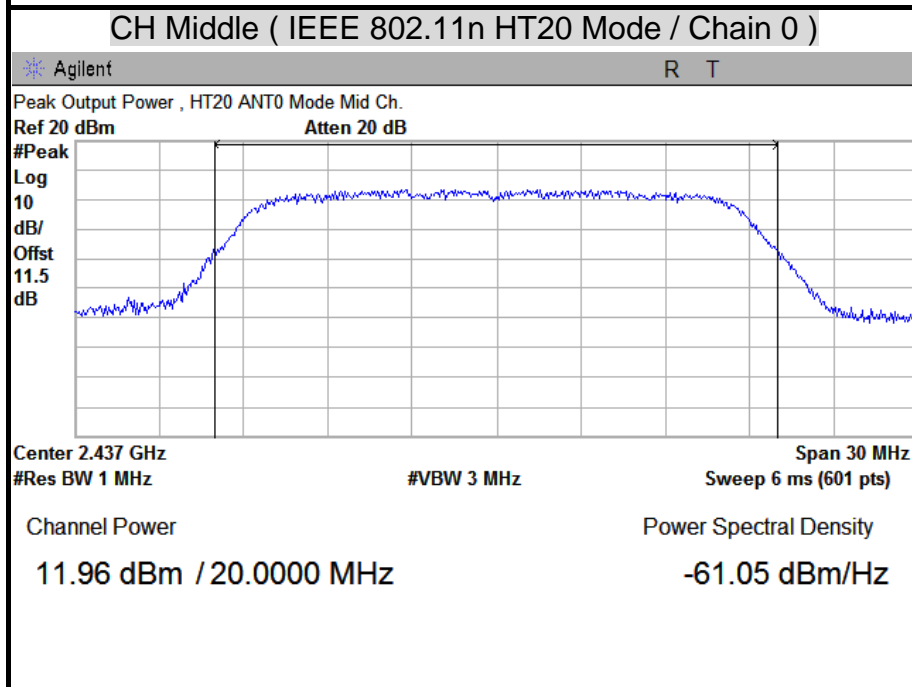
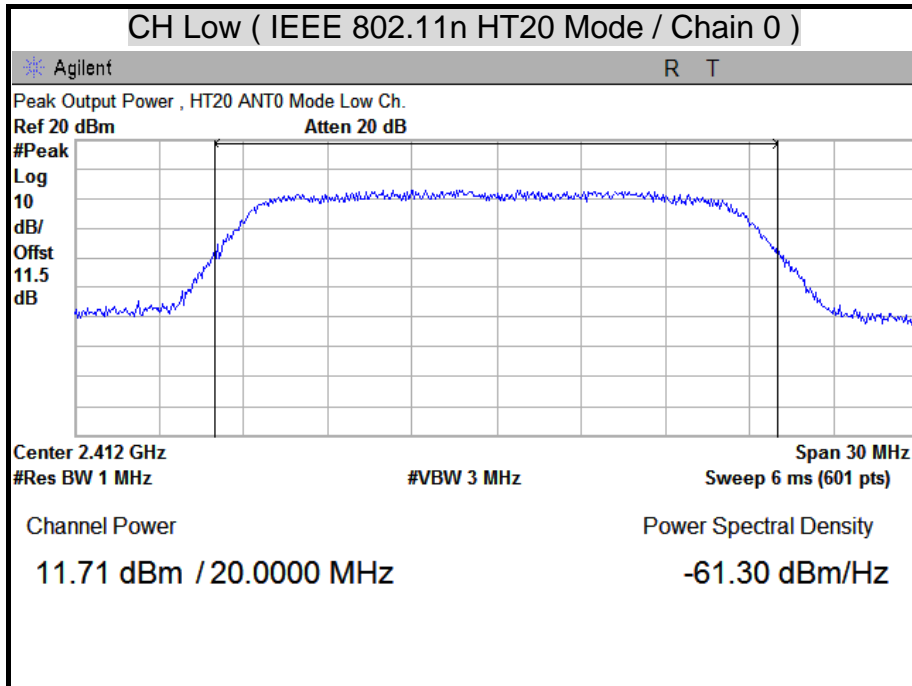

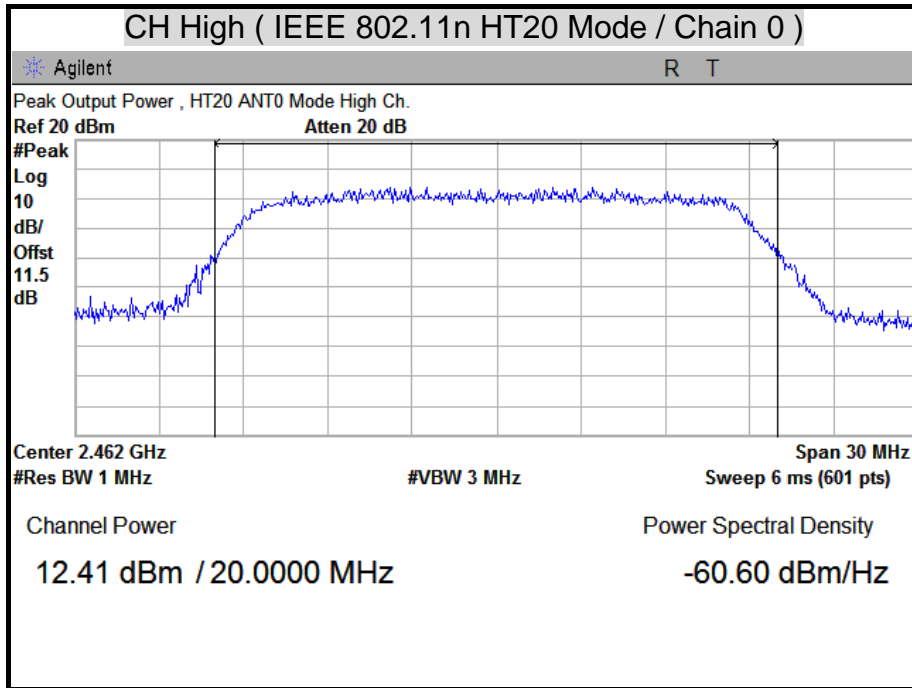

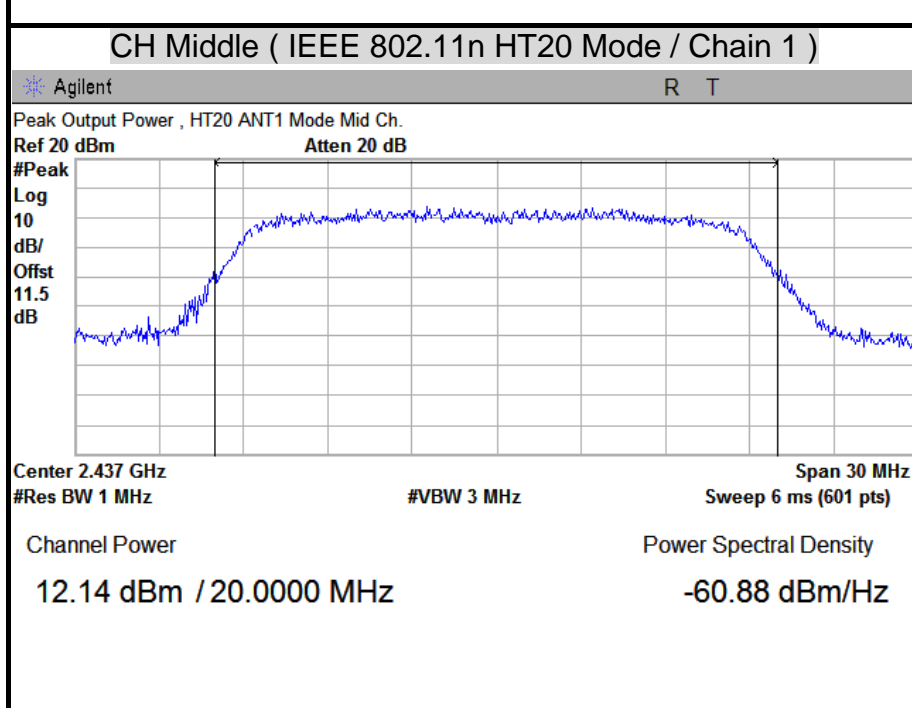
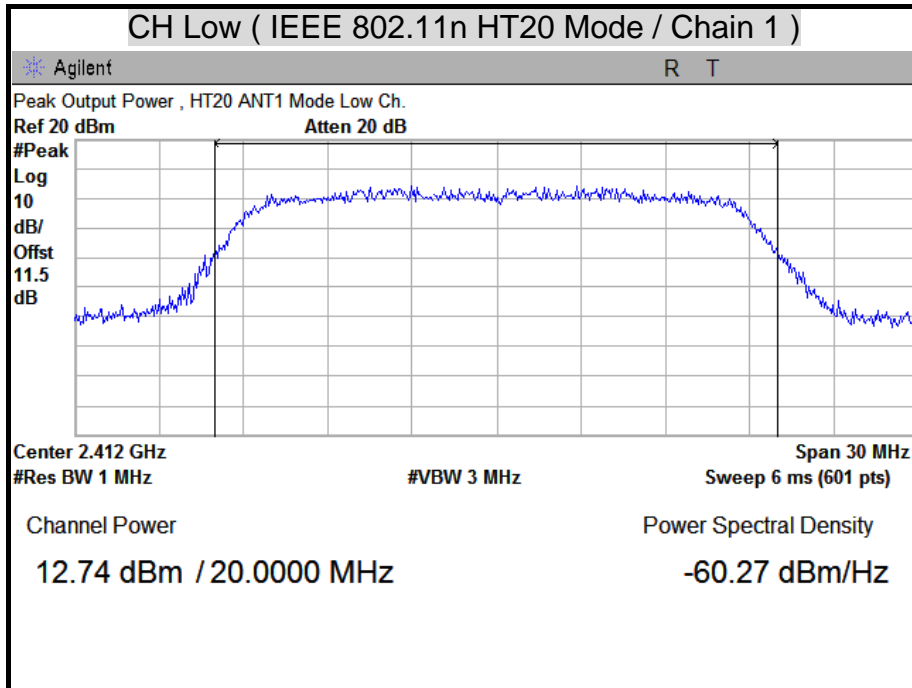

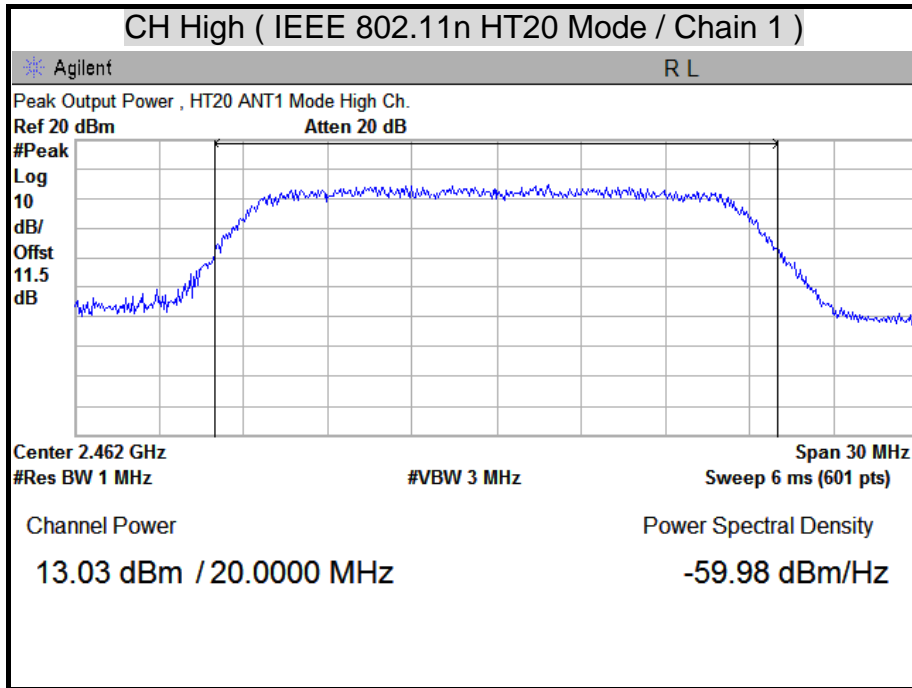

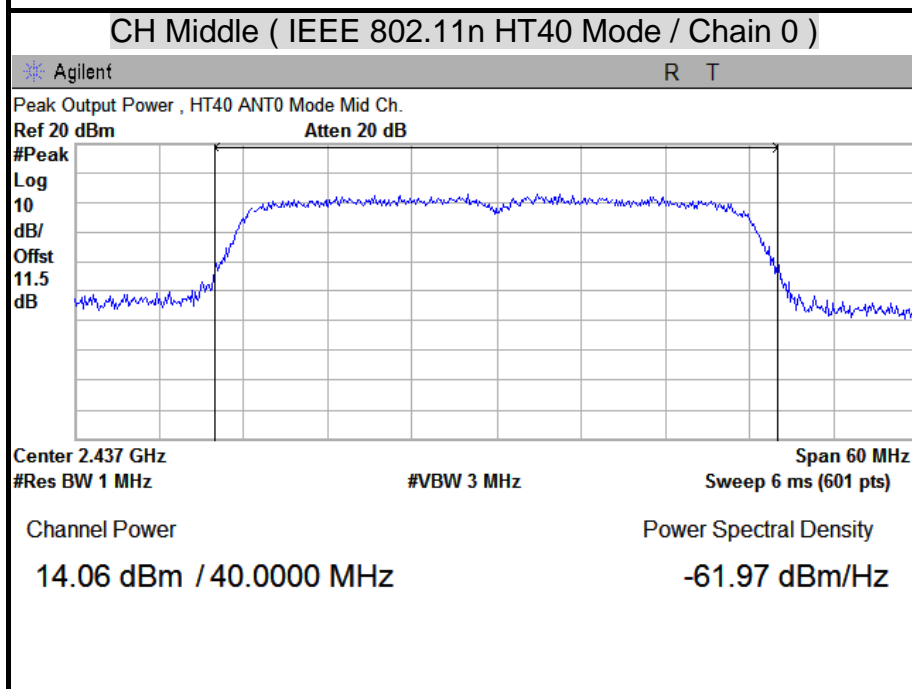
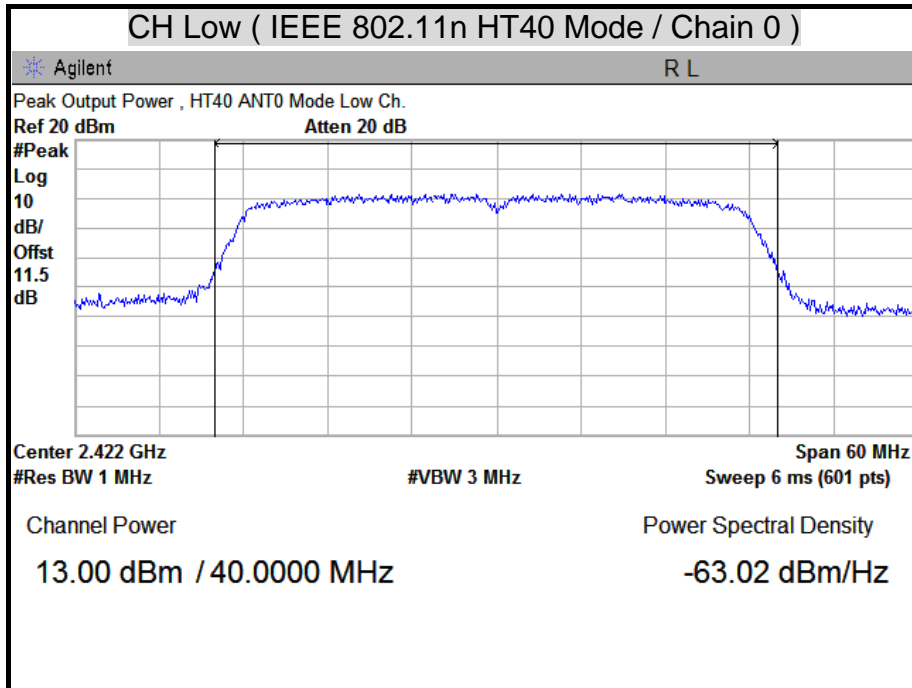

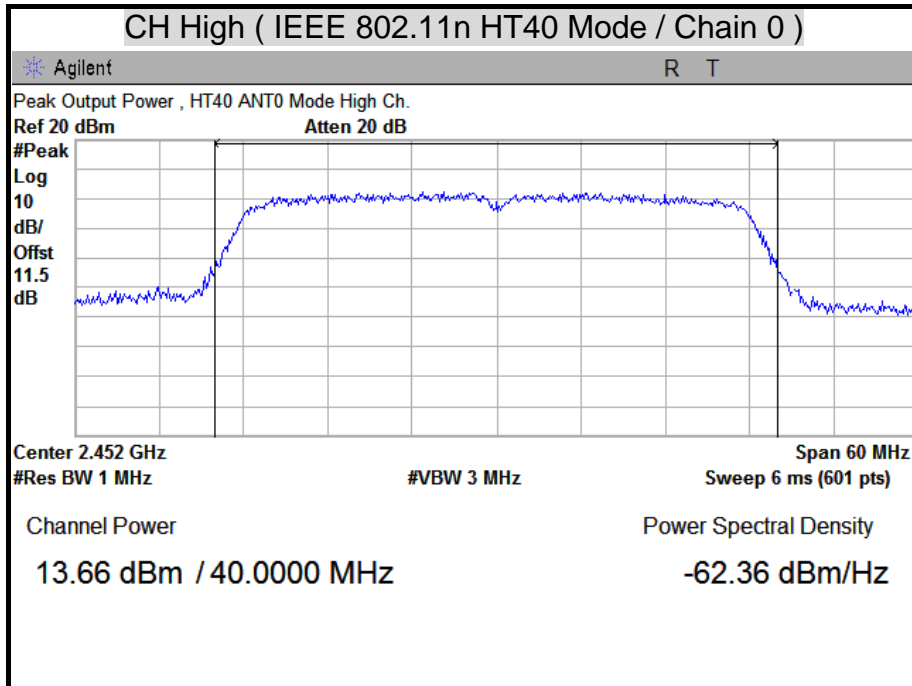

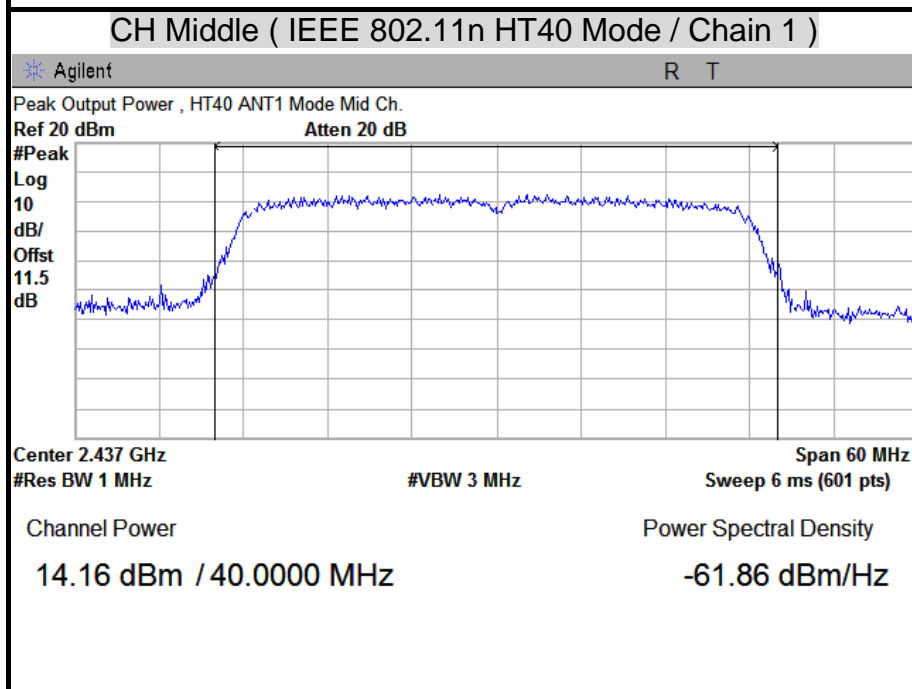
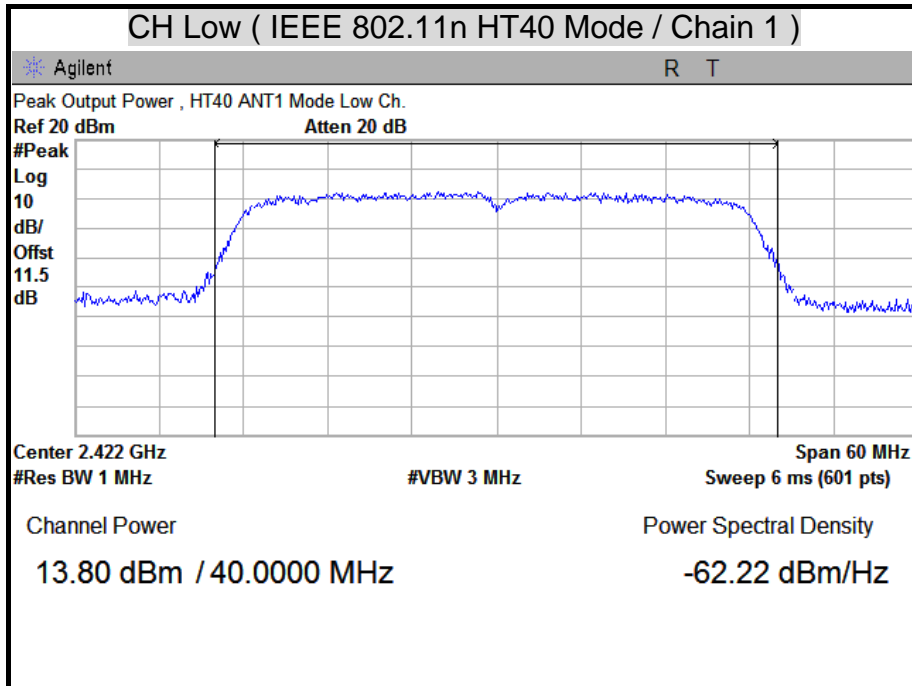

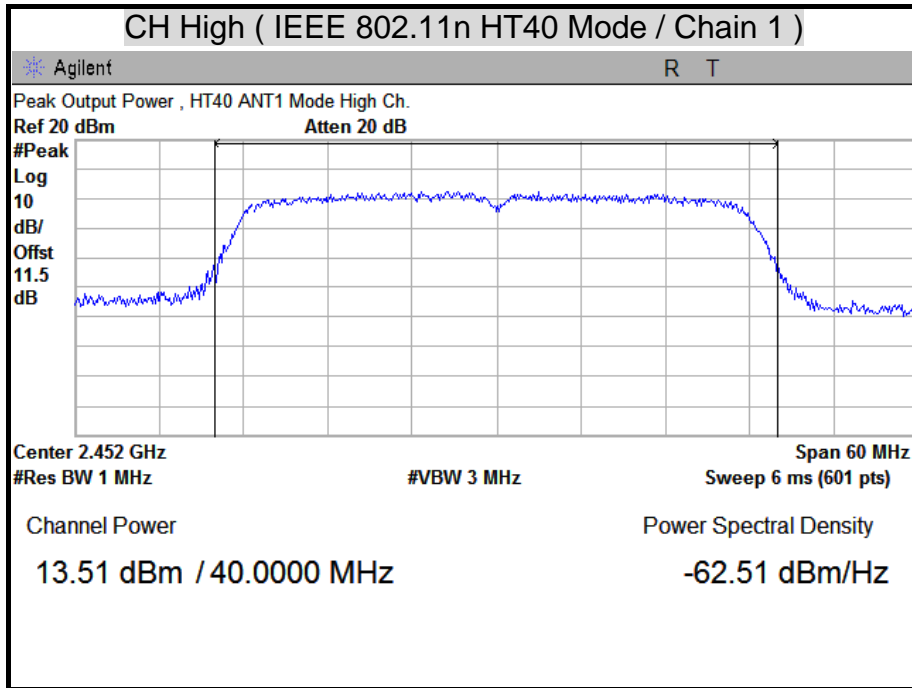



7.3 AVERAGE POWER

LIMITS

None; for reporting purposes only.

TEST EQUIPMENT

Name of Equipment	Manufacturer	Model	Serial Number	Calibration Due
Spectrum Analyzer	Agilent	E4407B	US41443108	08/09/2012

Remark: Each piece of equipment is scheduled for calibration once a year.

TEST SETUP

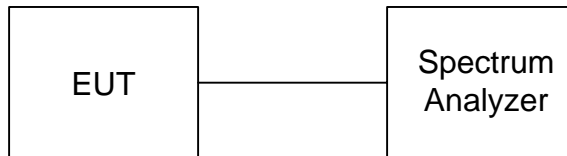

TEST PROCEDURE

The transmitter output is connected to a spectrum analyzer. The Spectrum analyzer is set to the average power detection.



TEST RESULTS

IEEE 802.11b Mode

Channel	Channel Frequency (MHz)	Average Power Output (dBm)
Low	2412	5.85
Middle	2437	5.13
High	2462	6.12

Remark:

1. At final test to get the worst-case emission at 1Mbps.
2. The cable assembly insertion loss of 11.5 dB (including 10 dB pad and 1.5 dB cable) was Entered as an offset in the spectrum analyzer to allow for direct reading of power.

IEEE 802.11g Mode

Channel	Channel Frequency (MHz)	Average Power Output (dBm)
Low	2412	6.86
Middle	2437	6.93
High	2462	8.20

Remark:

1. At final test to get the worst-case emission at 6Mbps.
2. The cable assembly insertion loss of 11.5 dB (including 10 dB pad and 1.5 dB cable) was Entered as an offset in the spectrum analyzer to allow for direct reading of power.



IEEE 802.11n HT20 Mode (Two TX)

Channel	Channel Frequency (MHz)	Average Power Output (dBm)		Average Power Total (dBm)
		Chain 0	Chain 1	
Low	2412	4.91	6.17	8.60
Middle	2437	5.84	5.39	8.63
High	2462	5.10	6.96	9.14

Remark:

1. At final test to get the worst-case emission at 6.5Mbps.
2. The cable assembly insertion loss of 11.5 dB (including 10 dB pad and 1.5 dB cable) was Entered as an offset in the spectrum analyzer to allow for direct reading of power.
3. Total average power = Chain 0 + Chain 1.

IEEE 802.11n HT40 Mode (Two TX)

Channel	Channel Frequency (MHz)	Average Power Output (dBm)		Average Power Total (dBm)
		Chain 0	Chain 1	
Low	2422	6.99	7.62	10.33
Middle	2437	8.00	8.00	11.01
High	2452	7.46	7.48	10.48

Remark:

1. At final test to get the worst-case emission at 13.5Mbps.
2. The cable assembly insertion loss of 11.5 dB (including 10 dB pad and 1.5 dB cable) was Entered as an offset in the spectrum analyzer to allow for direct reading of power.
3. Total average power = Chain 0 + Chain 1.



7.4 POWER SPECTRAL DENSITY

LIMITS

§ 15.247(e) For digitally modulated systems, the power spectral density conducted from the intentional radiator to the antenna shall not greater than 8 dBm in any 3 kHz band during any time interval of continuous transmission.

TEST EQUIPMENT

Name of Equipment	Manufacturer	Model	Serial Number	Calibration Due
Spectrum Analyzer	Agilent	E4407B	US41443108	08/09/2012

Remark: Each piece of equipment is scheduled for calibration once a year.

TEST SETUP

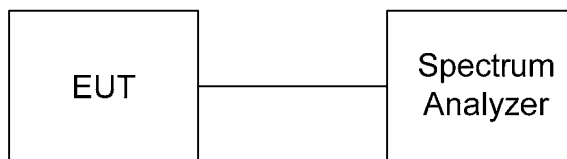

TEST PROCEDURE

The transmitter output was connected to the spectrum analyzer, the bandwidth of the fundamental frequency was measured with the spectrum analyzer using RBW = 3KHz and VBW = RBW, set sweep time = span / 3KHz.

The power spectral density was measured and recorded.

The sweep time is allowed to be longer than span / 3KHz for a full response of the mixer in the spectrum analyzer.



TEST RESULTS

IEEE 802.11b Mode

Channel	Channel Frequency (MHz)	Final RF Power Level in 3KHz BW (dBm)	Minimum Limit (dBm)	Pass / Fail
Low	2412	-22.86	8	PASS
Middle	2437	-23.62	8	PASS
High	2462	-22.57	8	PASS

Remark:

1. At final test to get the worst-case emission at 1Mbps.
2. The cable assembly insertion loss of 11.5 dB (including 10 dB pad and 1.5 dB cable) was Entered as an offset in the spectrum analyzer to allow for direct reading of power.

IEEE 802.11g Mode

Channel	Channel Frequency (MHz)	Final RF Power Level in 3KHz BW (dBm)	Minimum Limit (dBm)	Pass / Fail
Low	2412	-20.72	8	PASS
Middle	2437	-19.07	8	PASS
High	2462	-19.09	8	PASS

Remark:

1. At final test to get the worst-case emission at 6Mbps.
2. The cable assembly insertion loss of 11.5 dB (including 10 dB pad and 1.5 dB cable) was Entered as an offset in the spectrum analyzer to allow for direct reading of power.



IEEE 802.11n HT20 Mode (Two TX)

Channel	Channel Frequency (MHz)	Final RF Power Level in 3KHz BW (dBm)		PSD Total (dBm)	Minimum Limit (dBm)	Pass / Fail
		Chain 0	Chain 1			
Low	2412	-21.01	-19.82	-17.36	8	PASS
Middle	2437	-20.39	-19.57	-16.95	8	PASS
High	2462	-20.57	-19.75	-17.13	8	PASS

Remark:

1. At final test to get the worst-case emission at 6.5Mbps.
2. The cable assembly insertion loss of 11.5 dB (including 10 dB pad and 1.5 dB cable) was Entered as an offset in the spectrum analyzer to allow for direct reading of power.
3. Total power spectral density = Chain 0 + Chain 1.

IEEE 802.11n HT40 Mode (Two TX)

Channel	Channel Frequency (MHz)	Final RF Power Level in 3KHz BW (dBm)		PSD Total (dBm)	Minimum Limit (dBm)	Pass / Fail
		Chain 0	Chain 1			
Low	2422	-20.01	-20.86	-17.40	8	PASS
Middle	2437	-18.41	-20.79	-16.43	8	PASS
High	2452	-18.81	-20.49	-16.56	8	PASS

Remark:

1. At final test to get the worst-case emission at 13.5Mbps.
2. The cable assembly insertion loss of 11.5 dB (including 10 dB pad and 1.5 dB cable) was Entered as an offset in the spectrum analyzer to allow for direct reading of power.
3. Total power spectral density = Chain 0 + Chain 1.



POWER SPECTRAL DENSITY

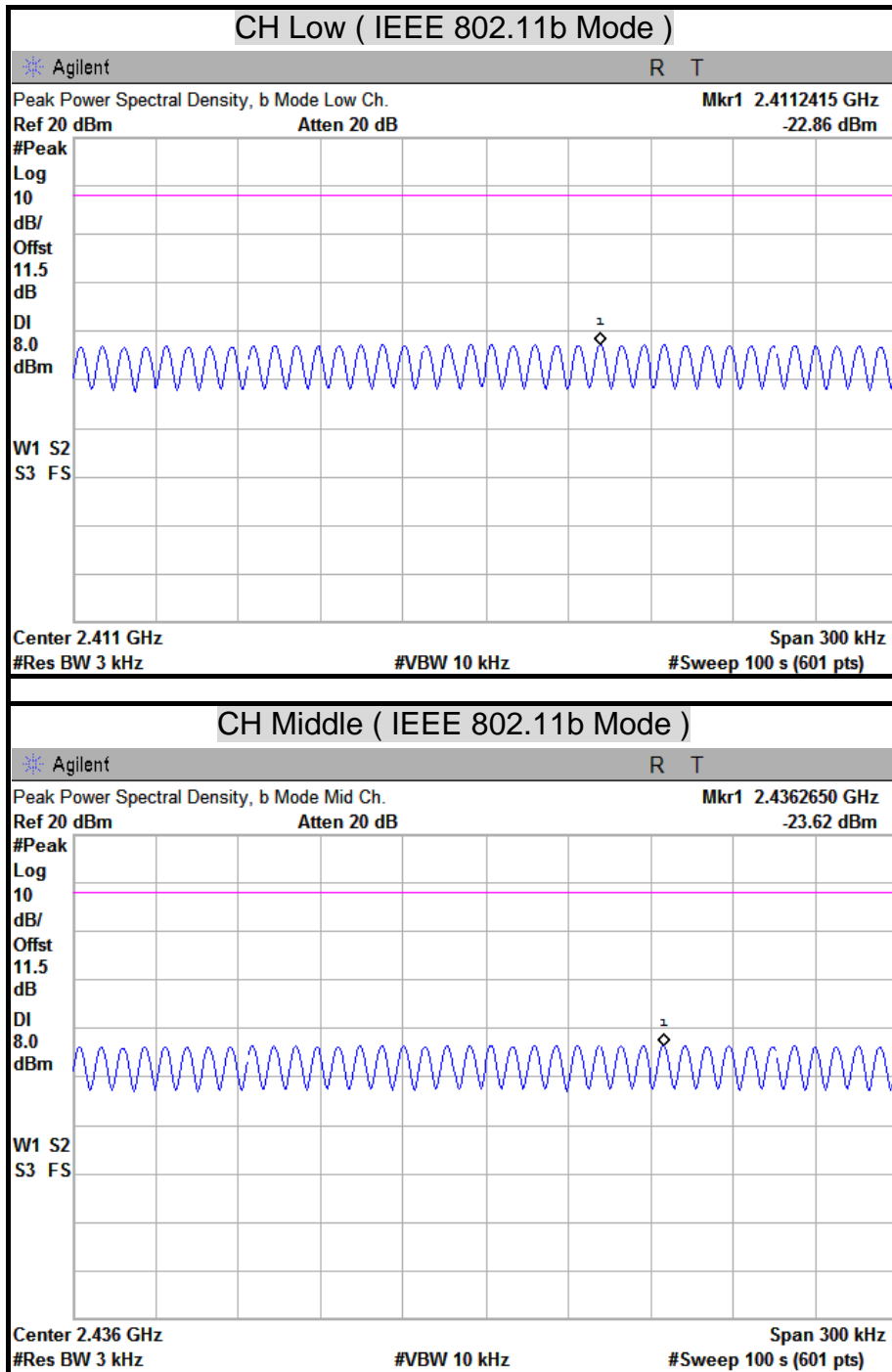

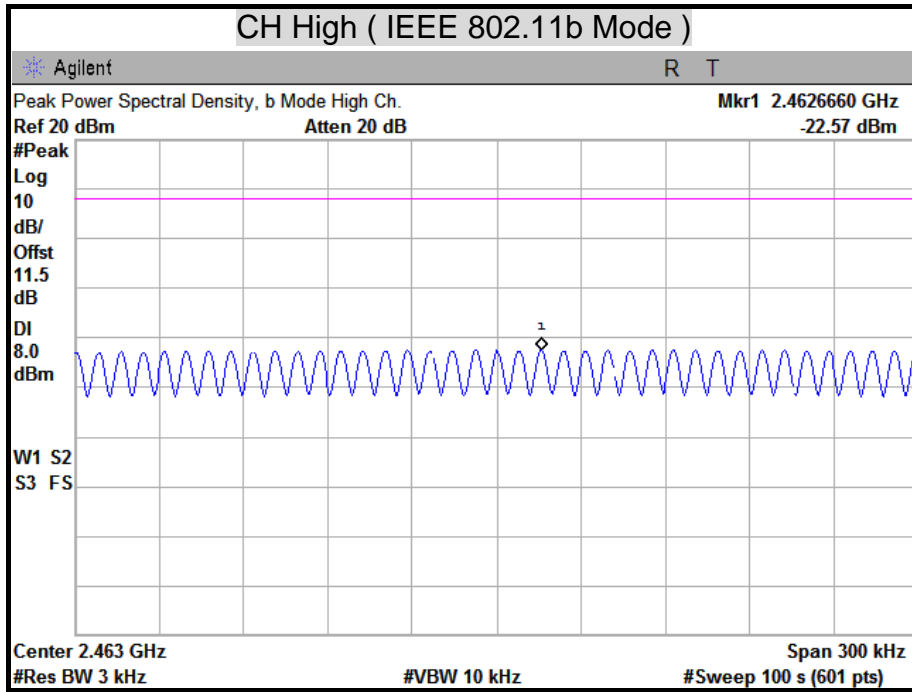

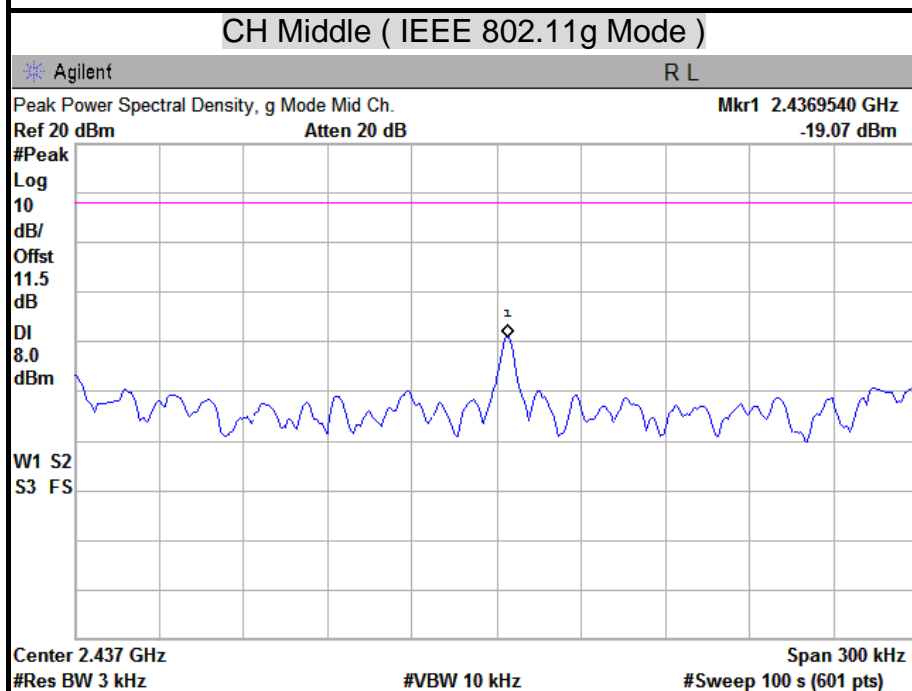
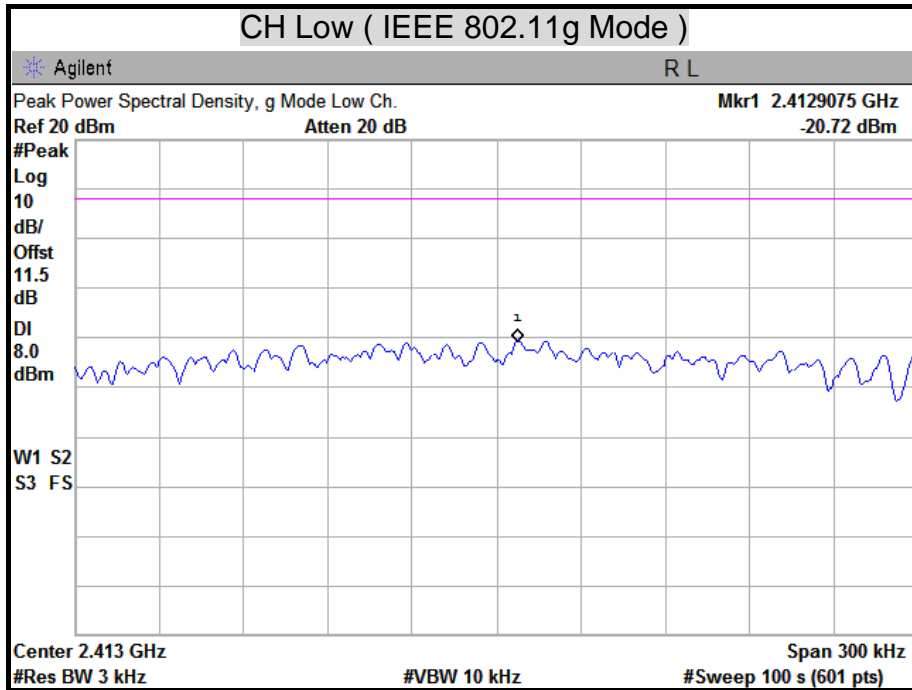

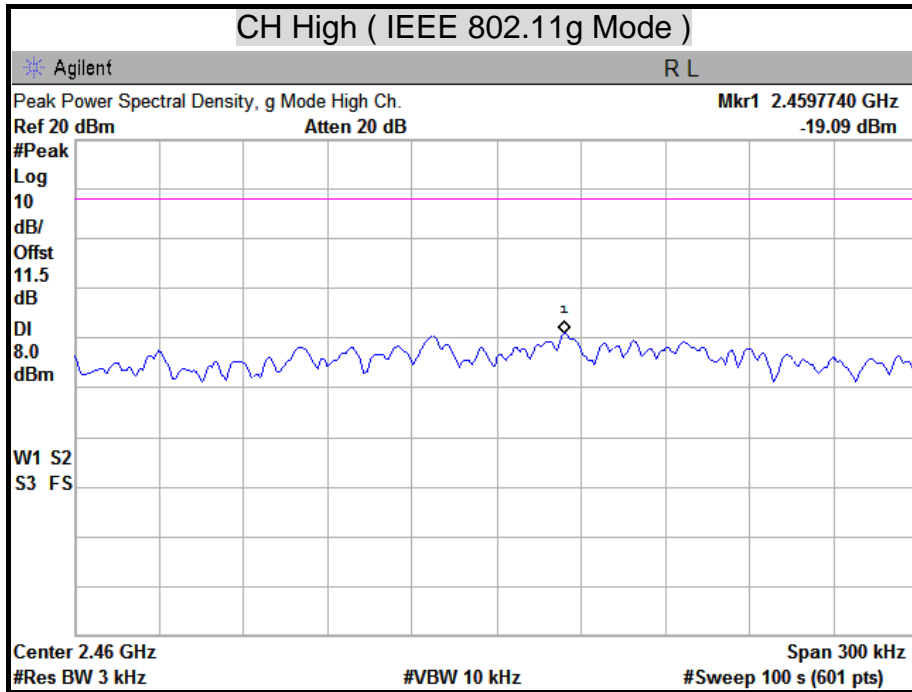

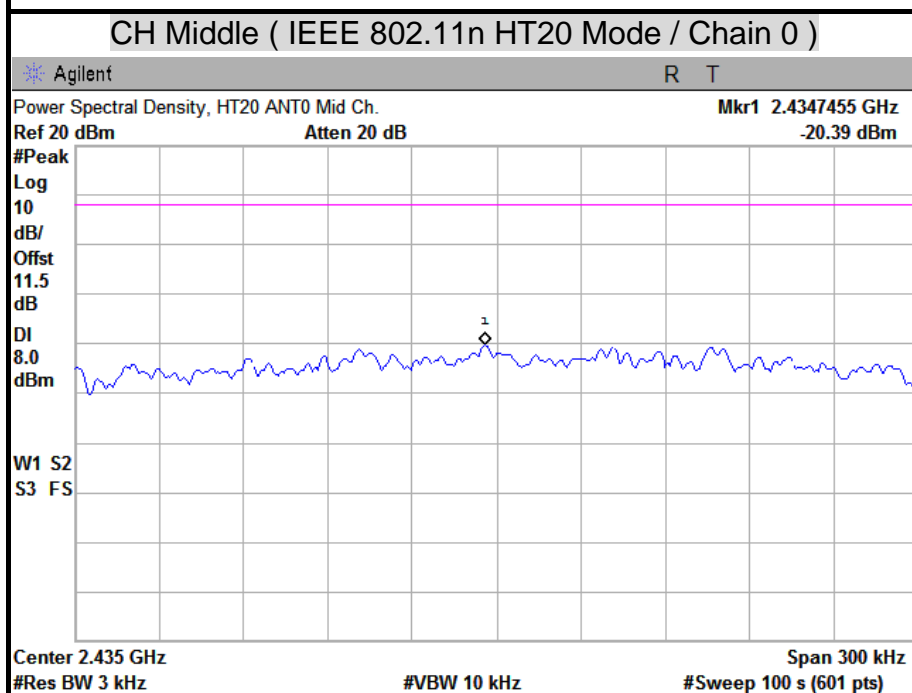
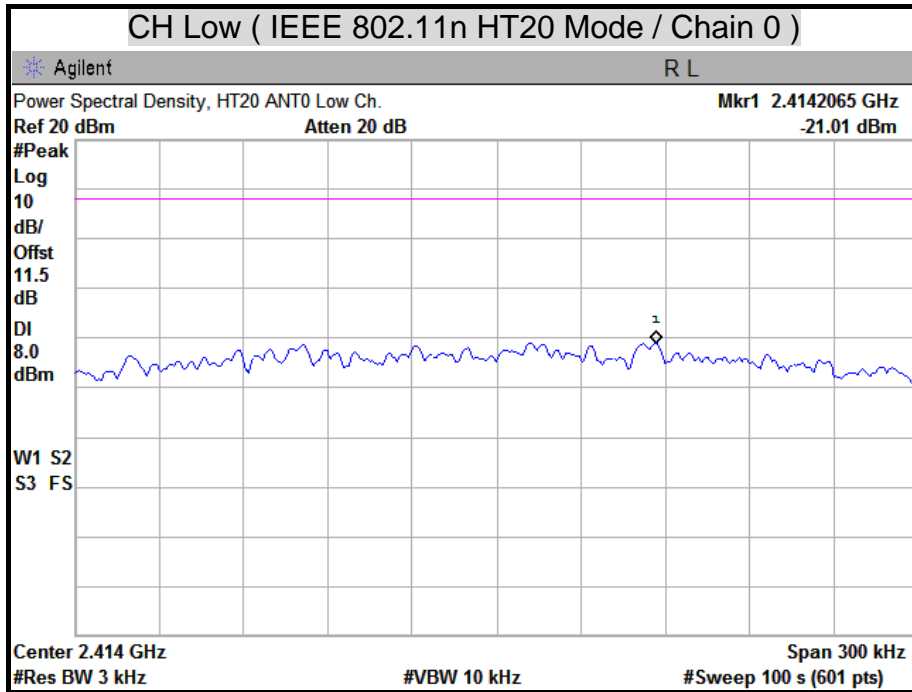

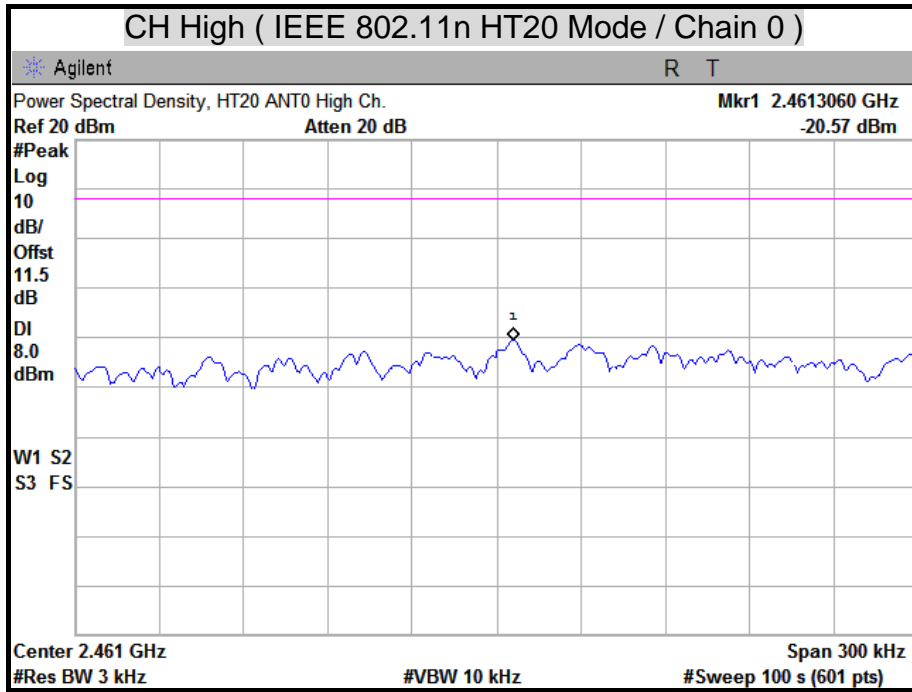

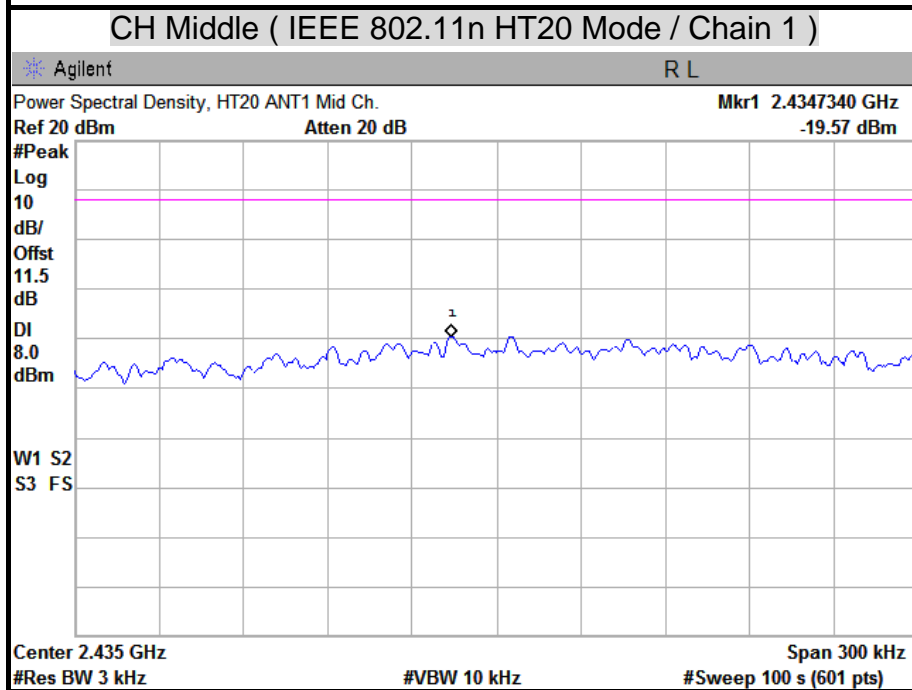
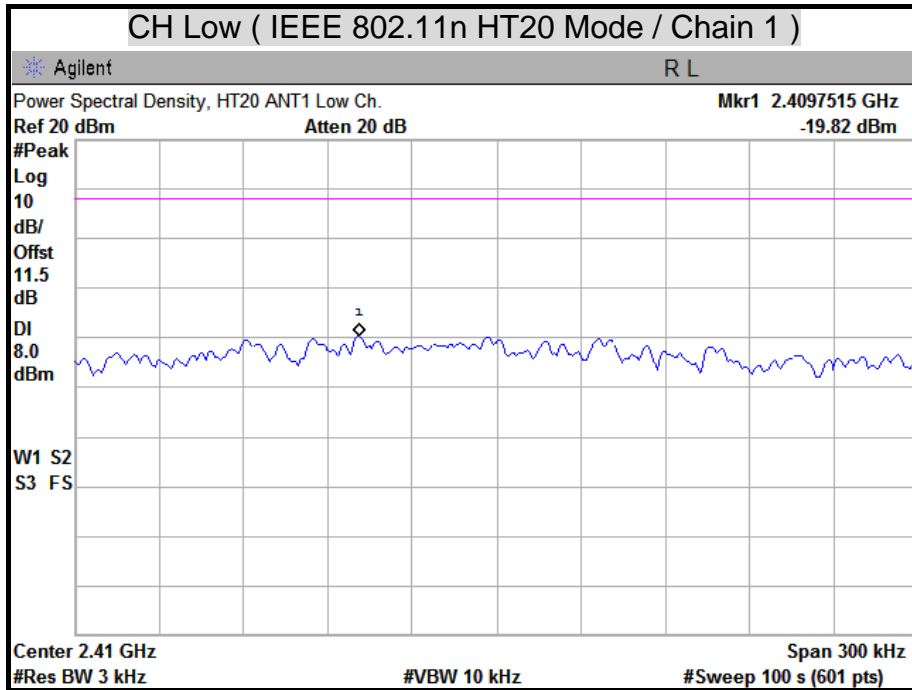

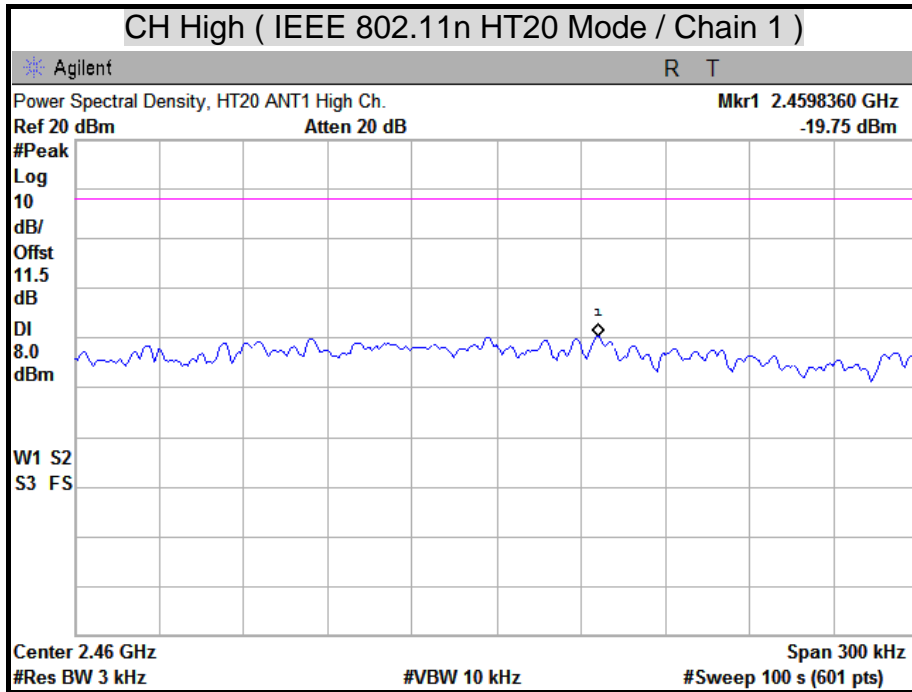

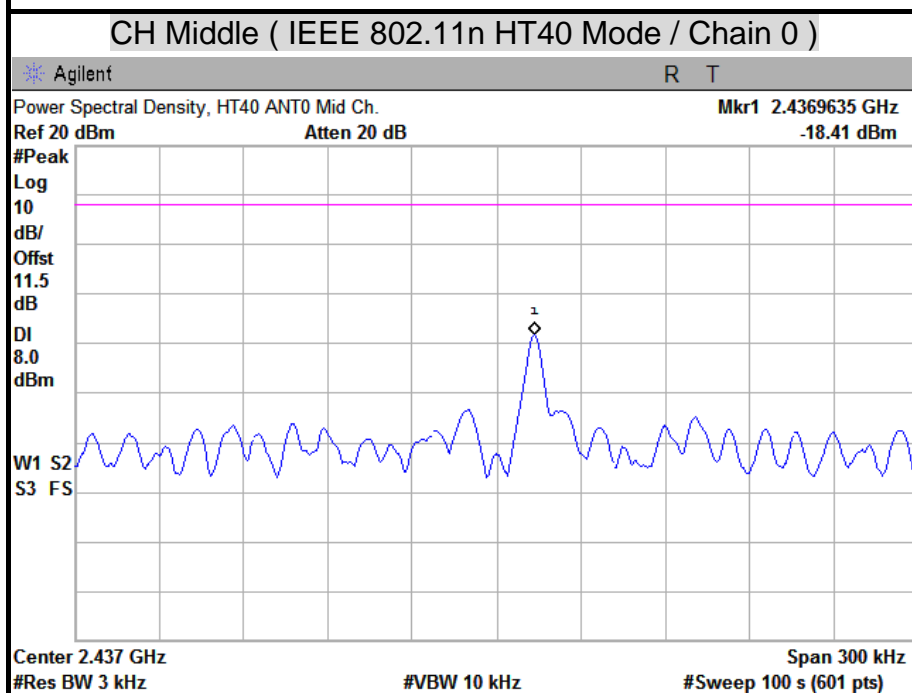
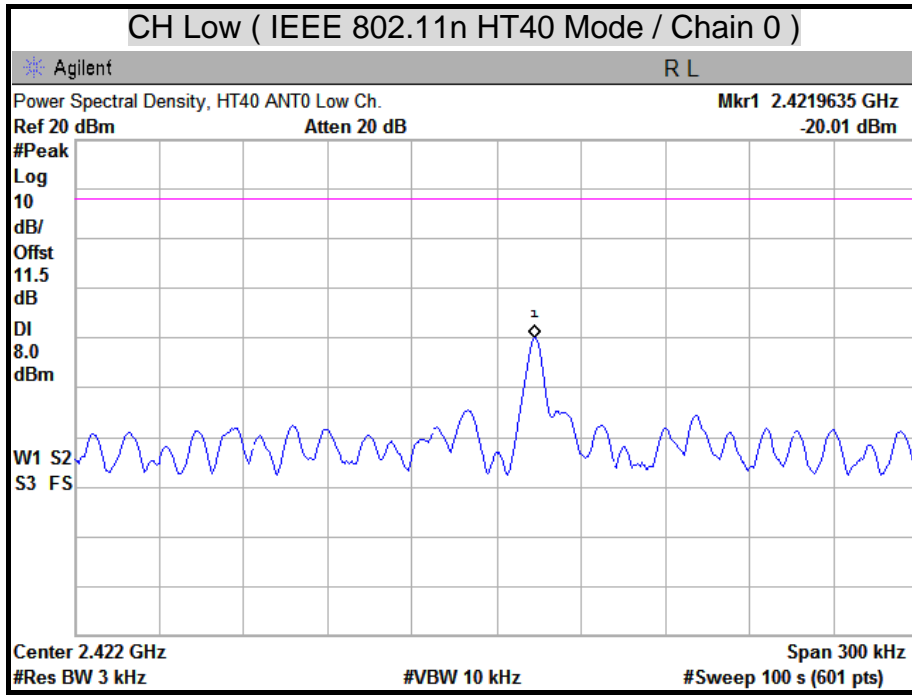

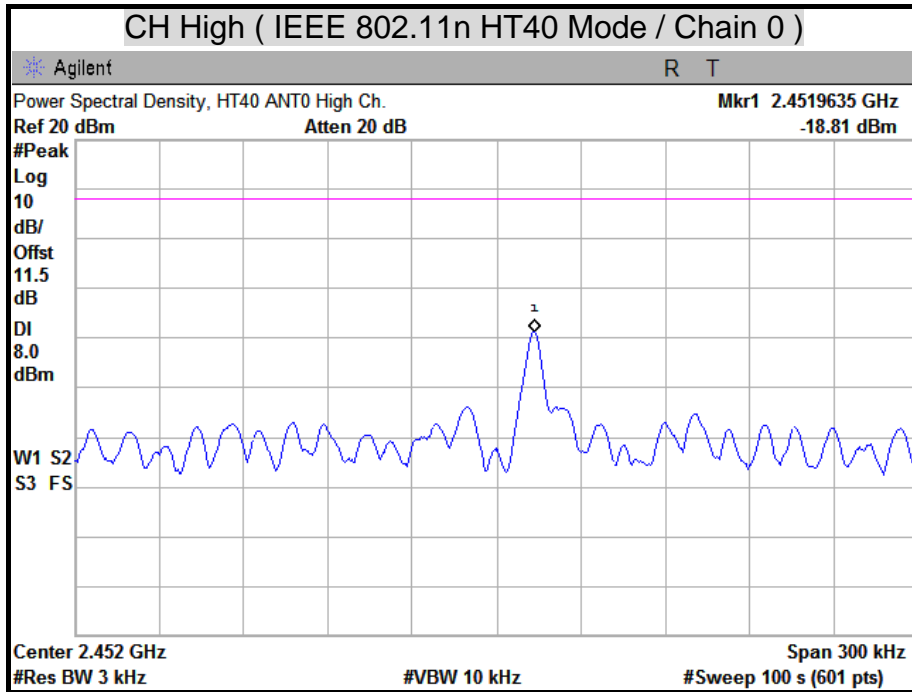

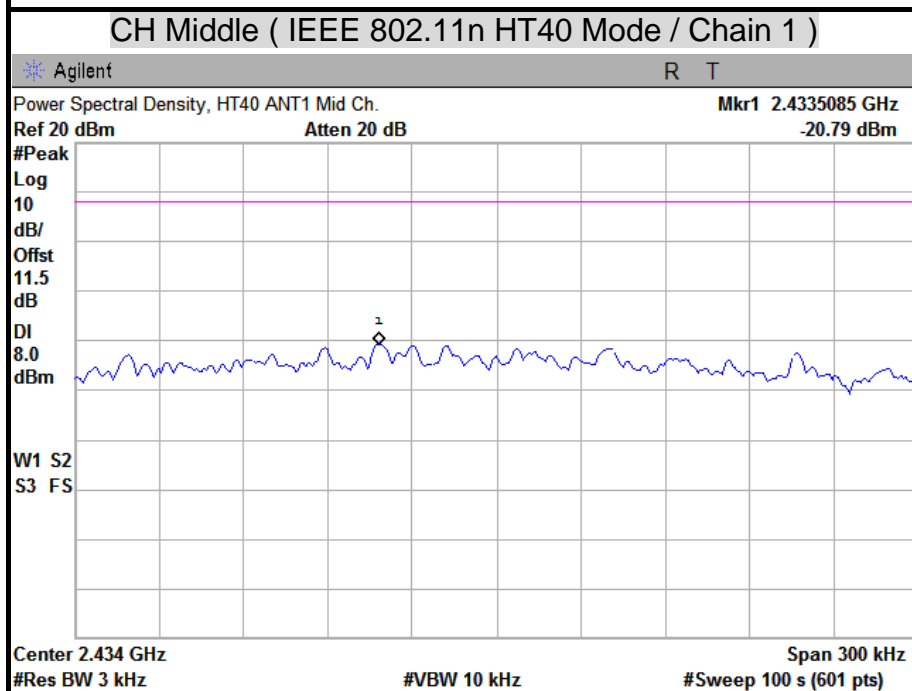
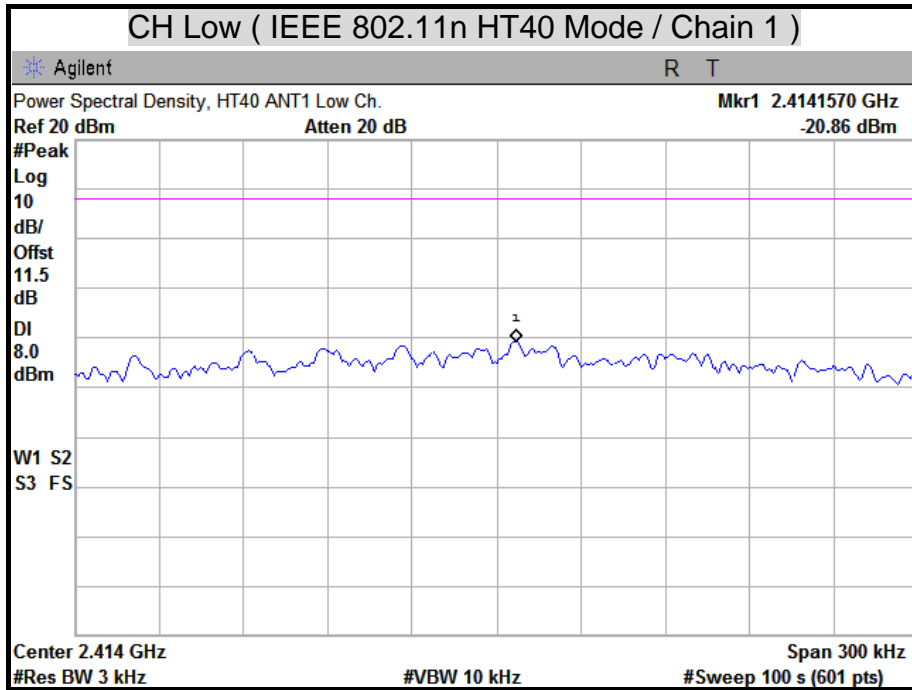

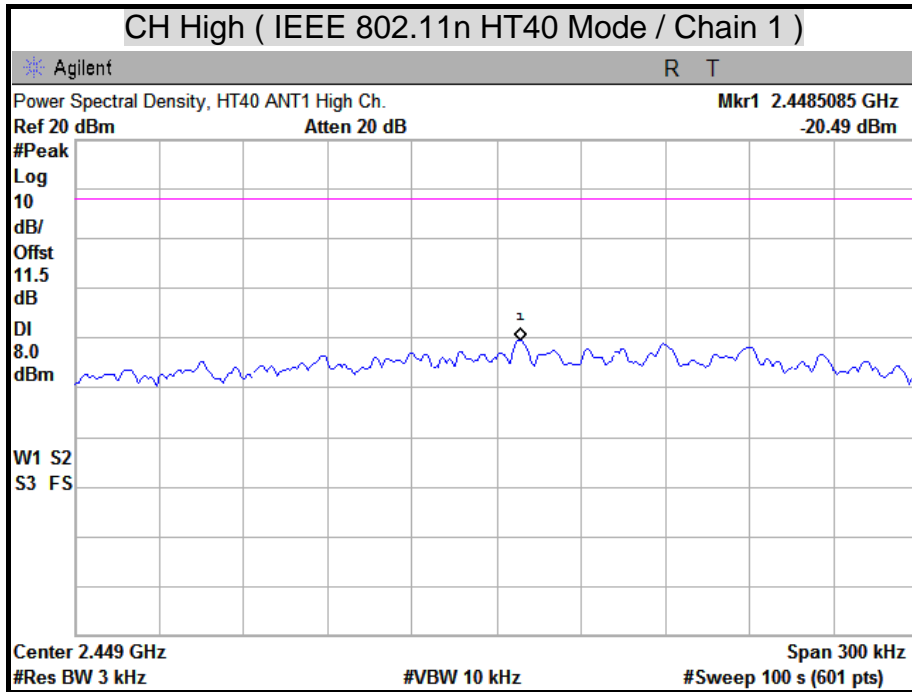



7.5 CONDUCTED SPURIOUS EMISSION

LIMITS

§ 15.247(d) In any 100 kHz bandwidth outside the frequency band in which the spread spectrum intentional radiator is operating, the radio frequency power that is produced by the intentional radiator shall be at least 20 dB below that in the 100 kHz bandwidth within the and that contains the highest level of the desired power, based on either an RF conducted or a radiated measurement. Attenuation below the general limits specified in § 15.209(a) is not required. In addition, radiated emissions which fall in the restricted bands, as defined in § 15.205(a), must also comply with the radiated emission limits specified in § 15.209(a) (see § 15.205(c)).

TEST EQUIPMENT

Name of Equipment	Manufacturer	Model	Serial Number	Calibration Due
Spectrum Analyzer	Agilent	E4407B	US41443108	08/09/2012

Remark: Each piece of equipment is scheduled for calibration once a year.

TEST SETUP

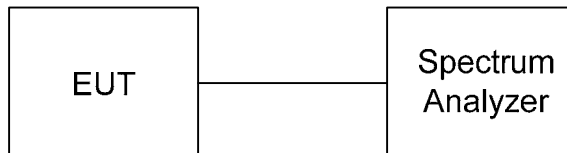

TEST PROCEDURE

The transmitter output is connected to a spectrum analyzer. The resolution bandwidth is set to 100 kHz. The video bandwidth is set to 300 kHz.

The spectrum from 30 MHz to 26 GHz is investigated with the transmitter set to the lowest, middle, and highest channels in the 2.4 GHz band.



TEST RESULTS

OUT-OF-BAND SPURIOUS EMISSIONS-CONDUCTED MEASUREMENT

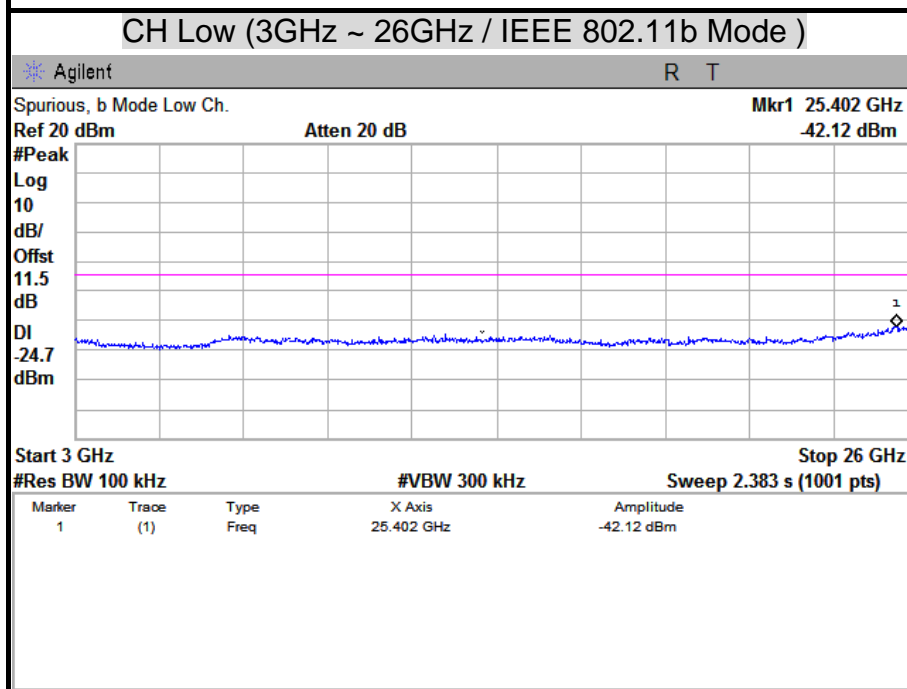
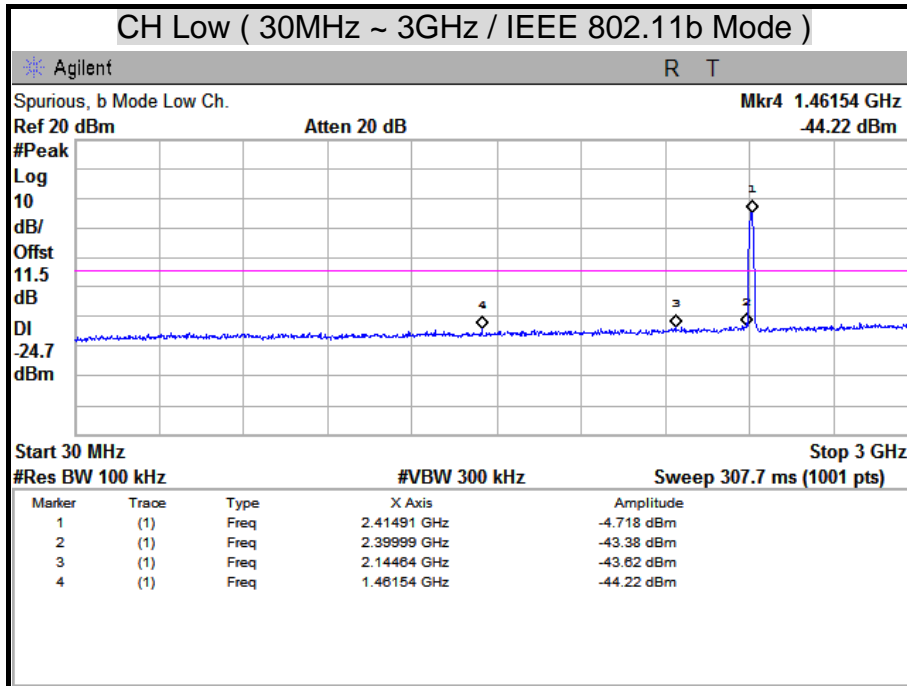

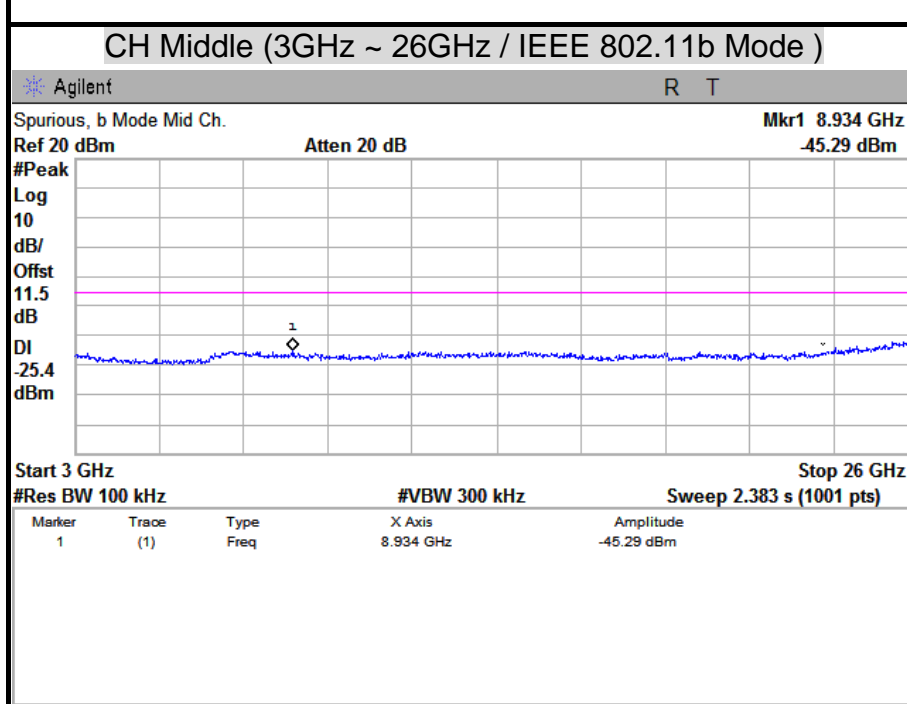
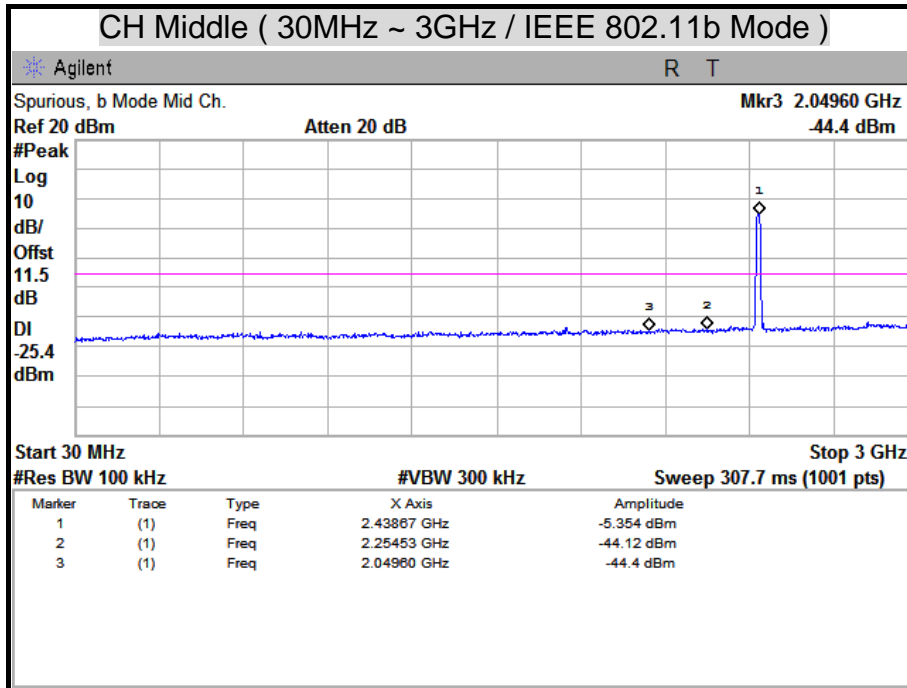

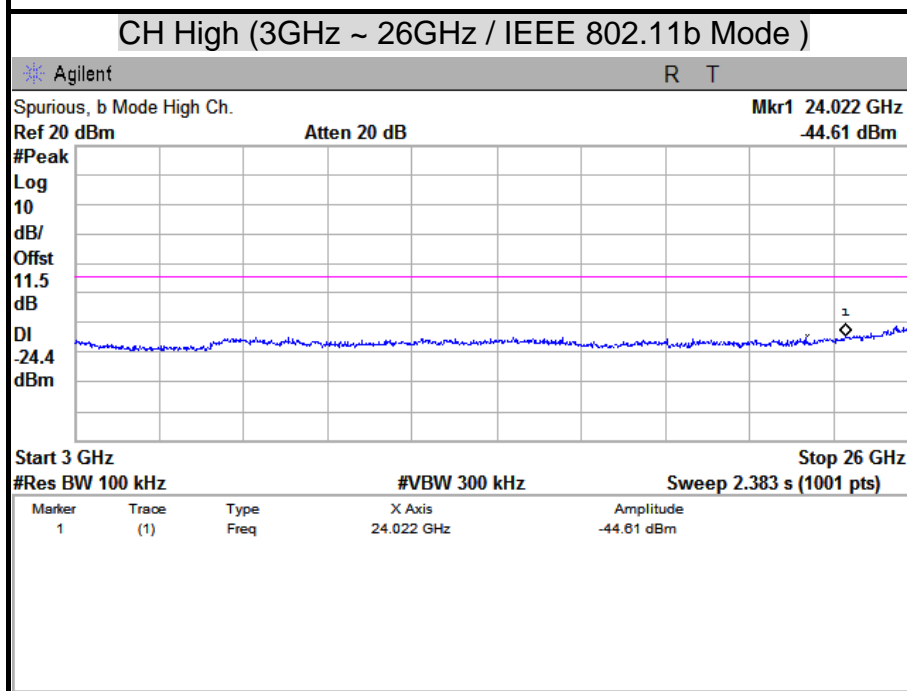
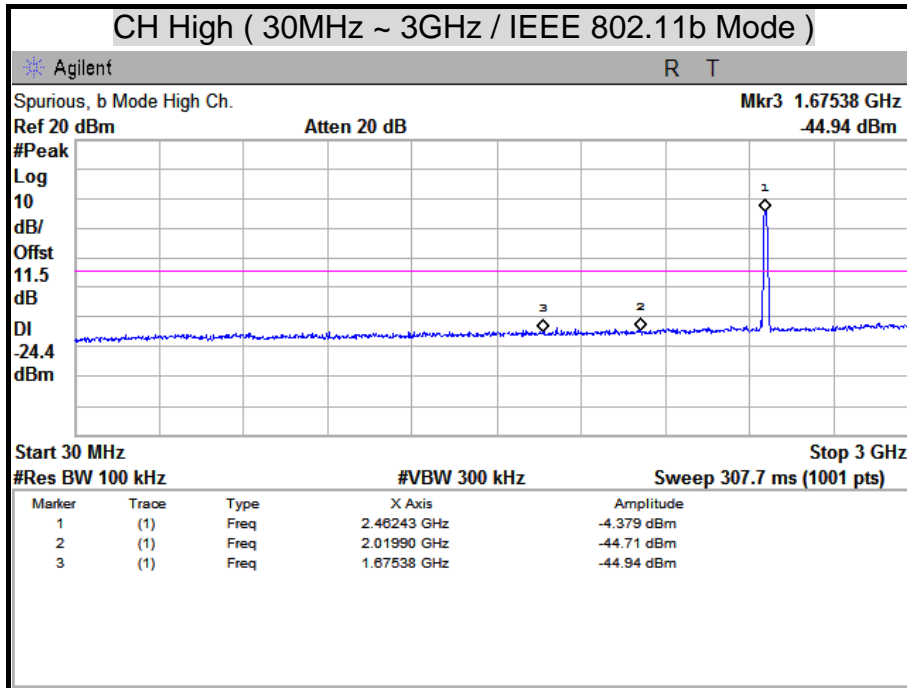

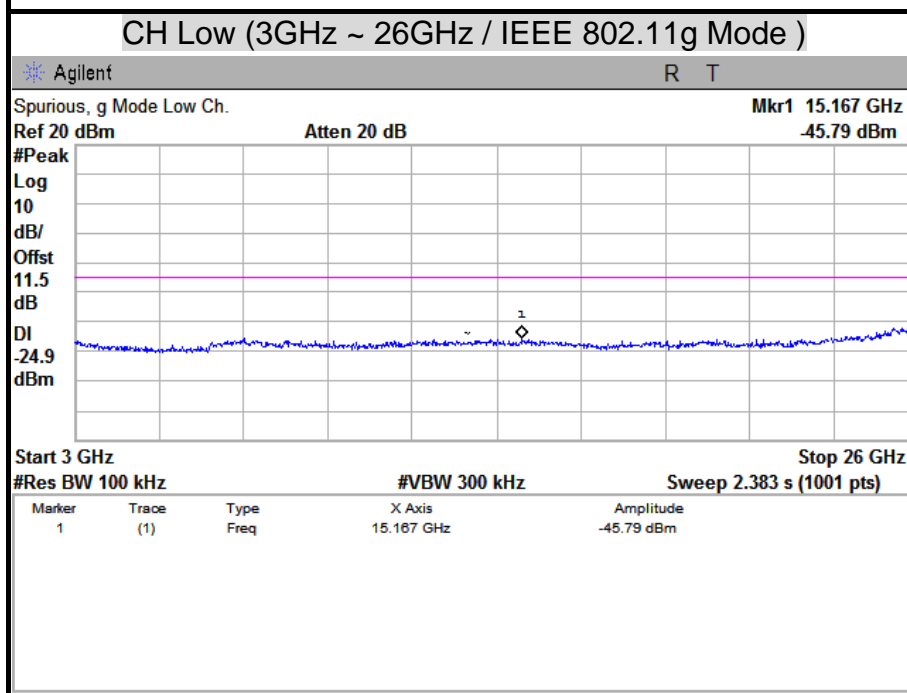
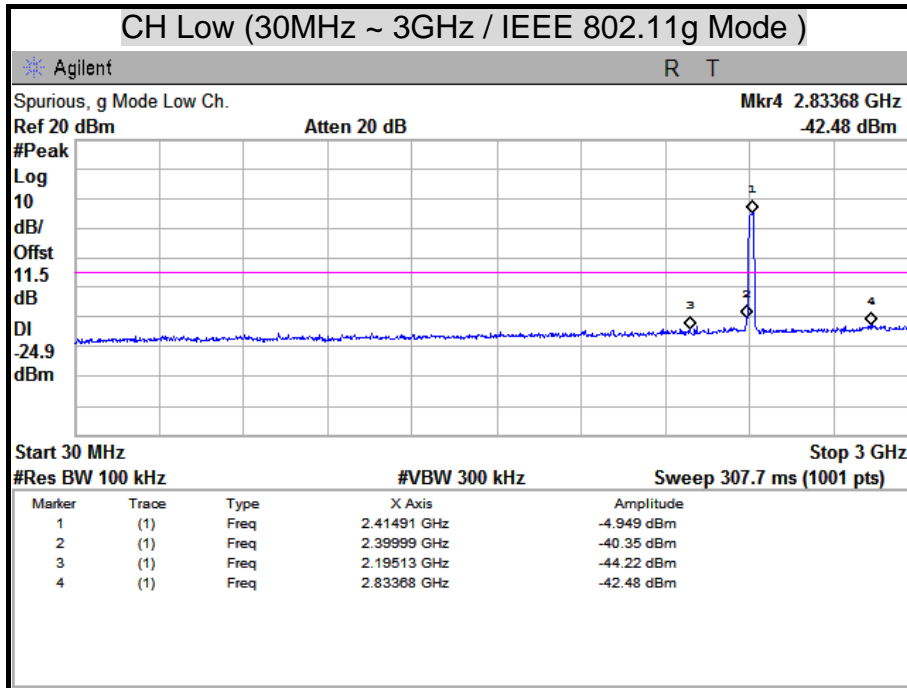

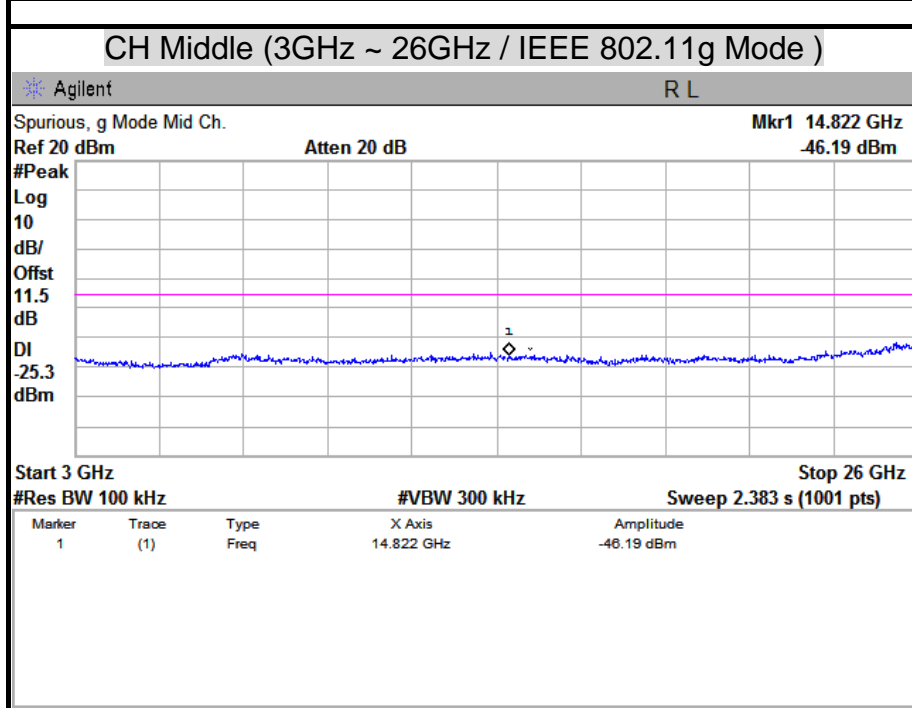
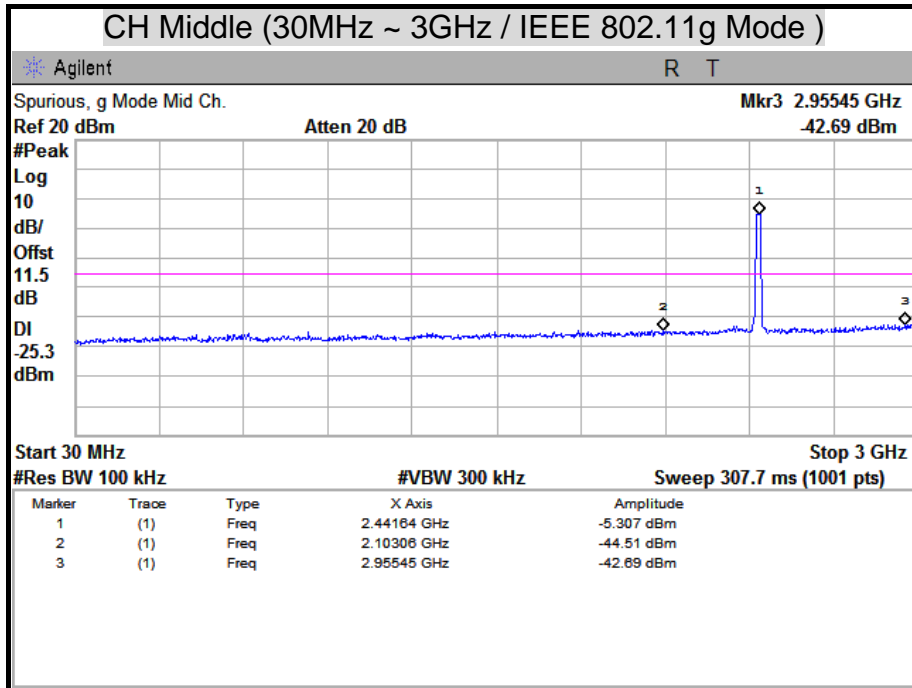

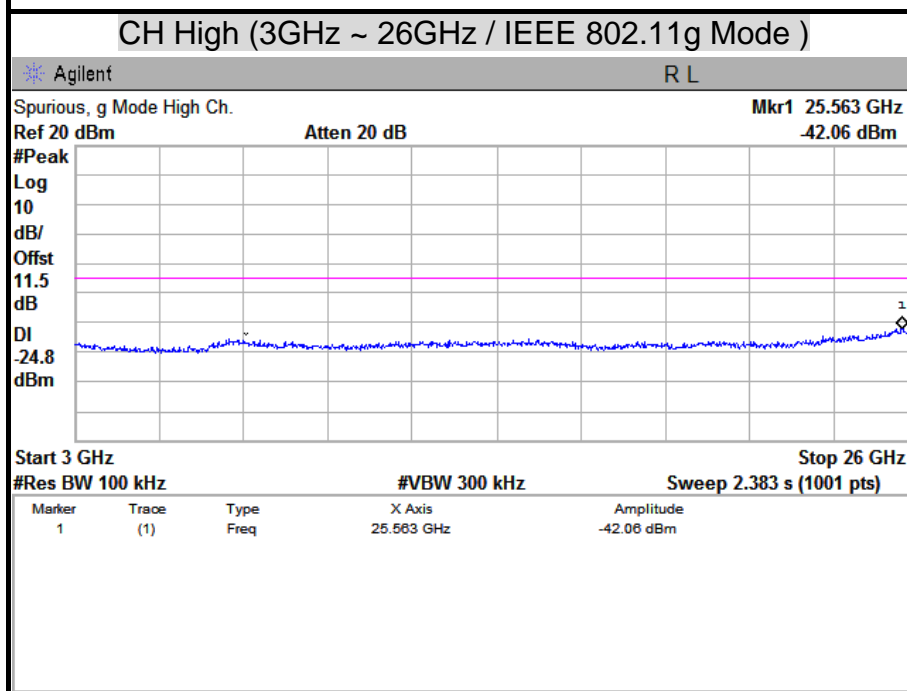
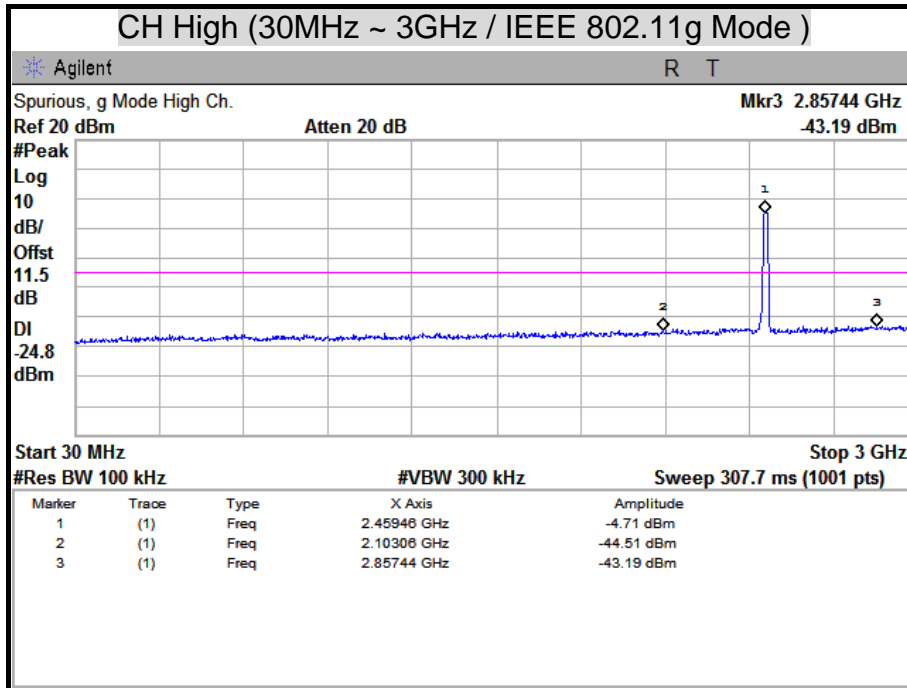

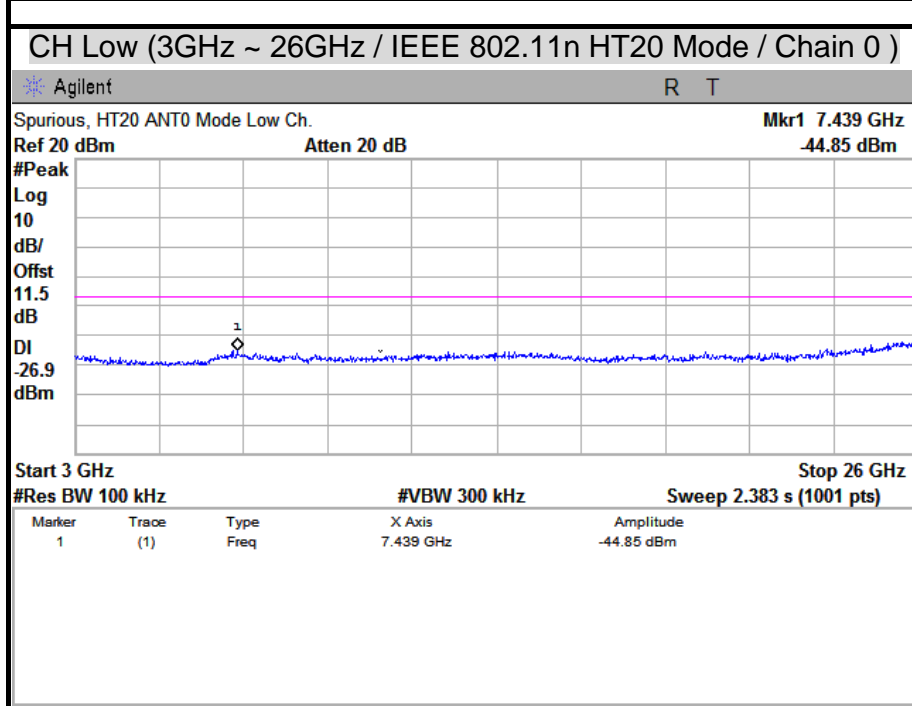
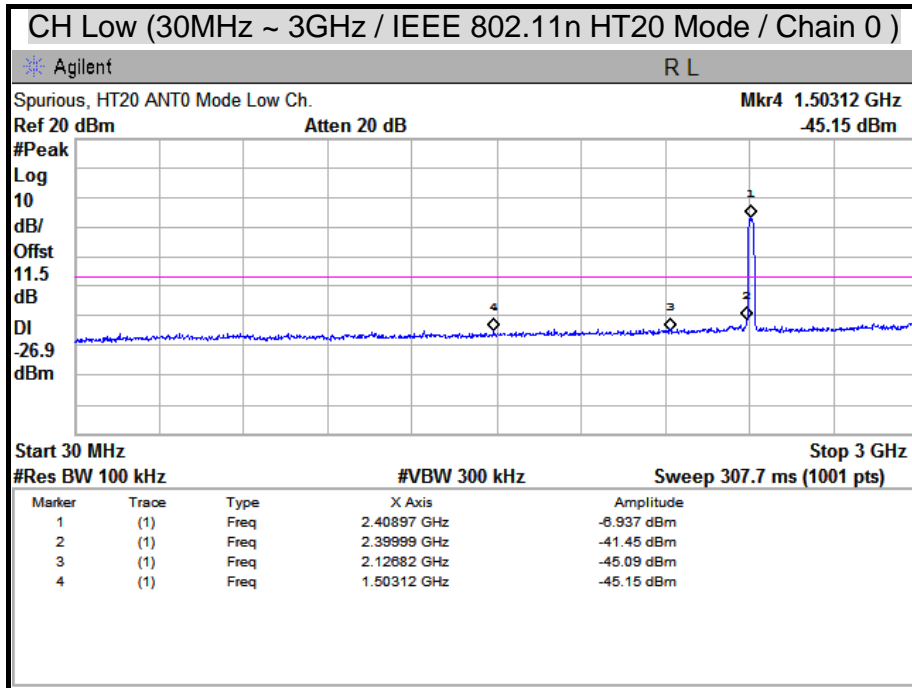

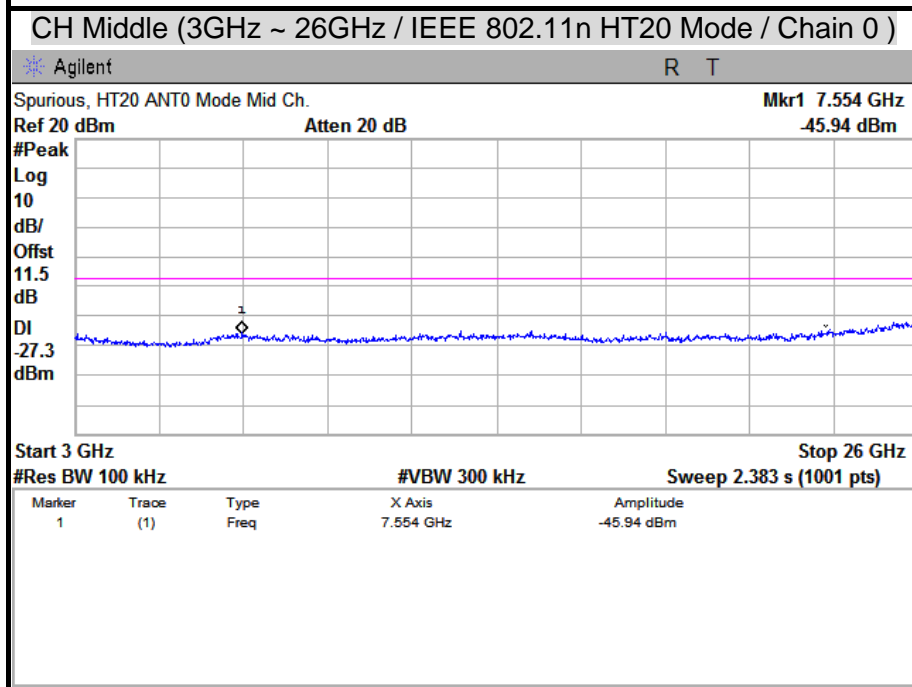
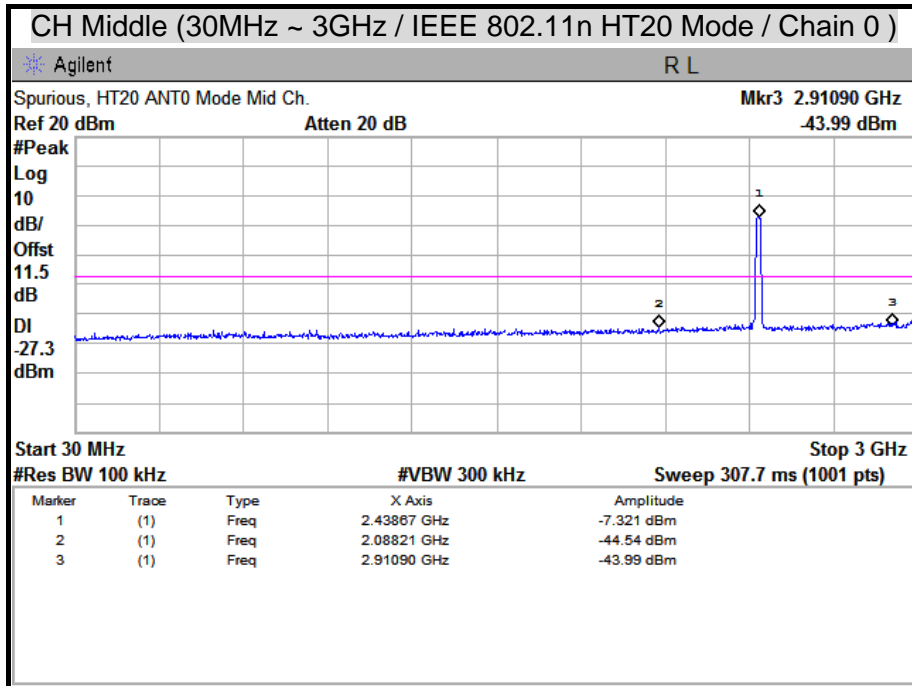

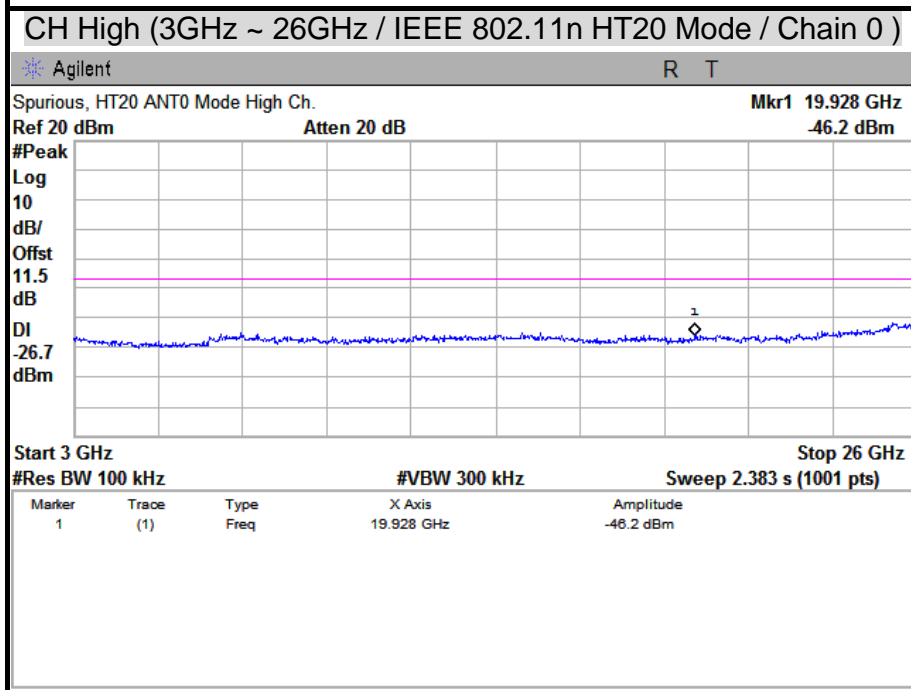
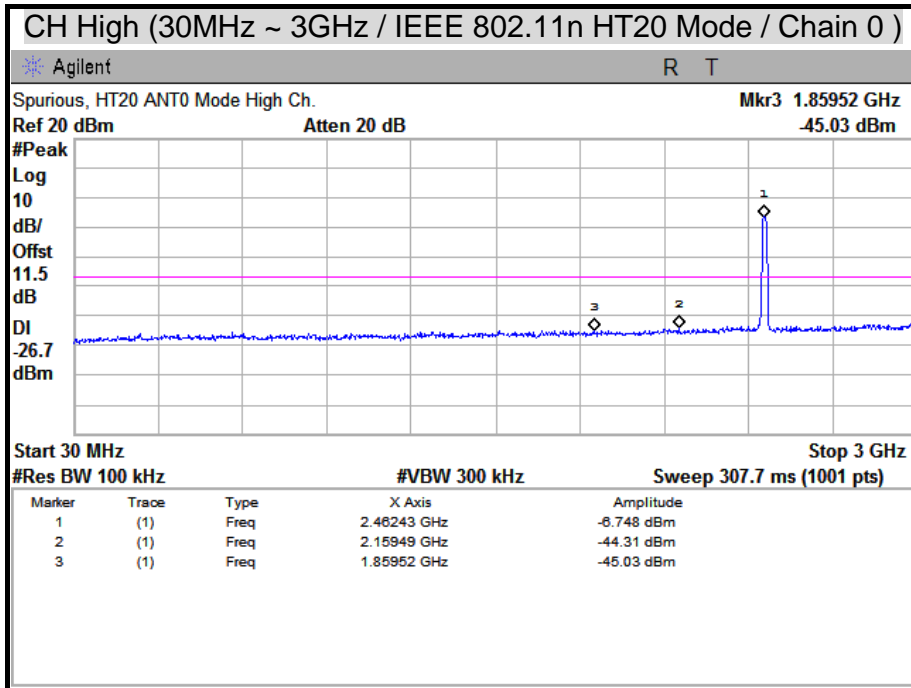

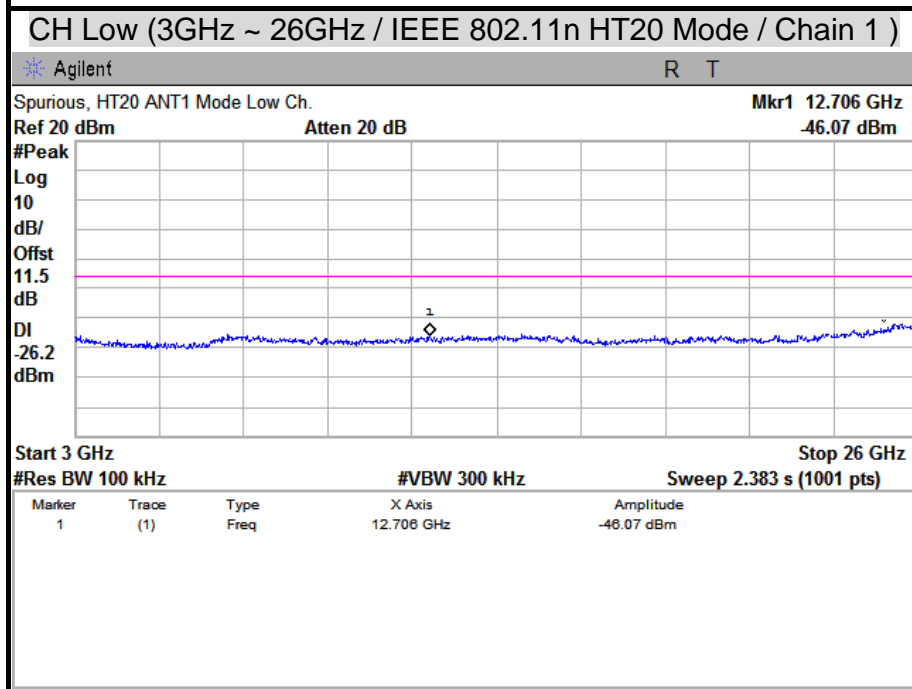
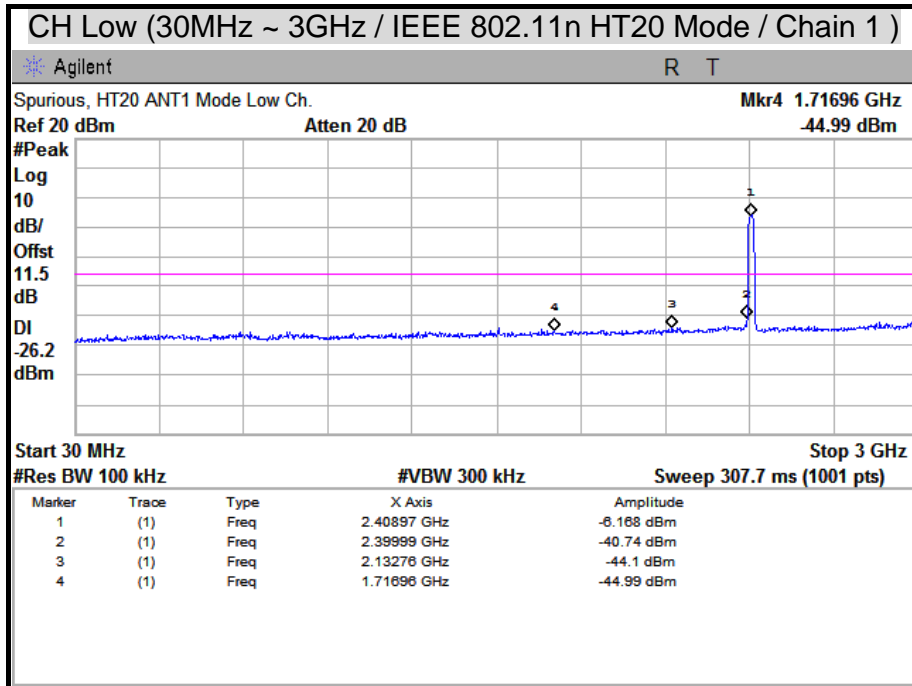

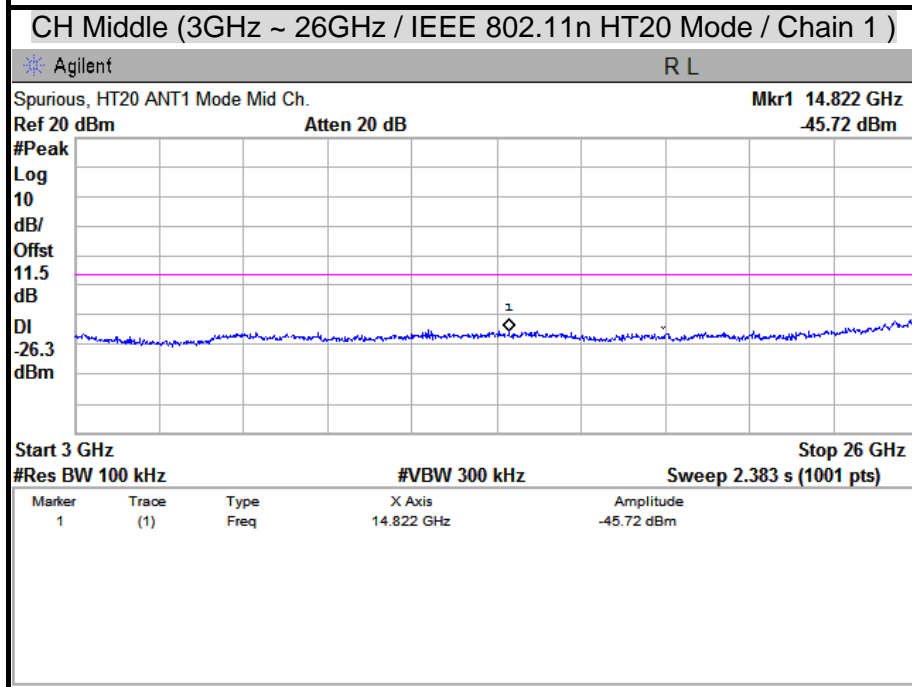
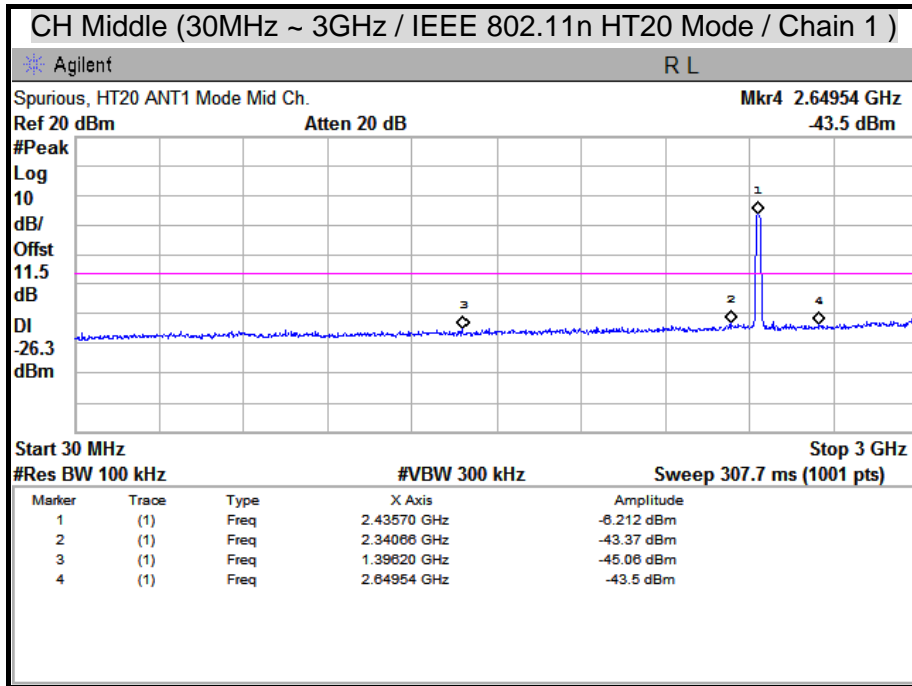

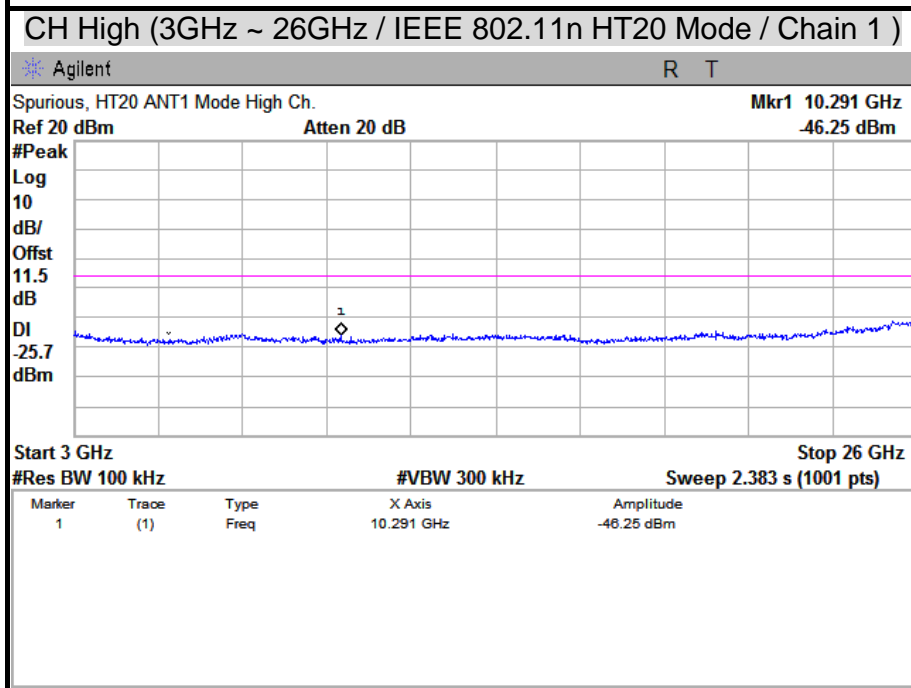
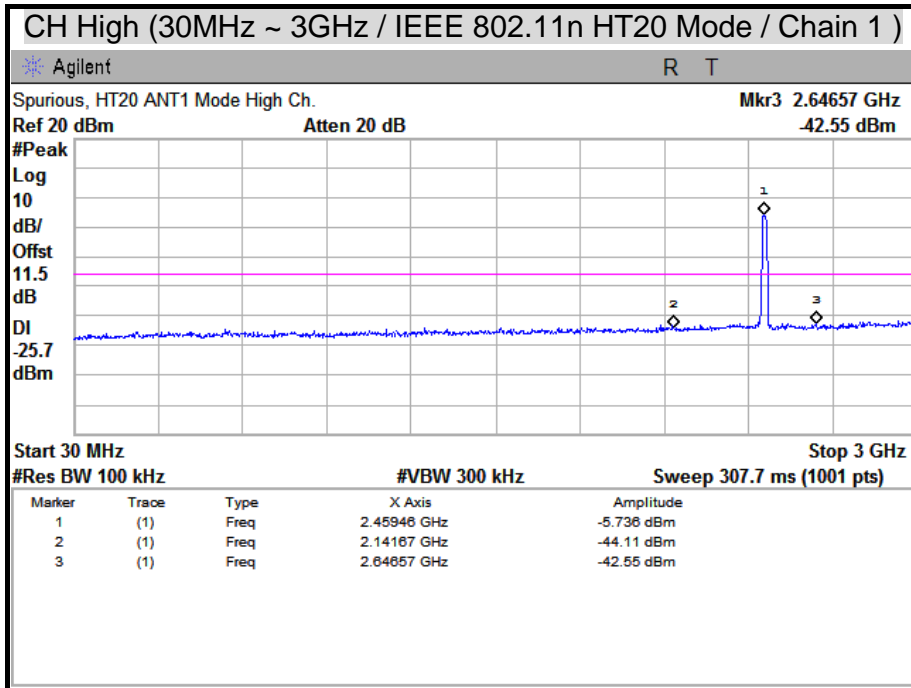

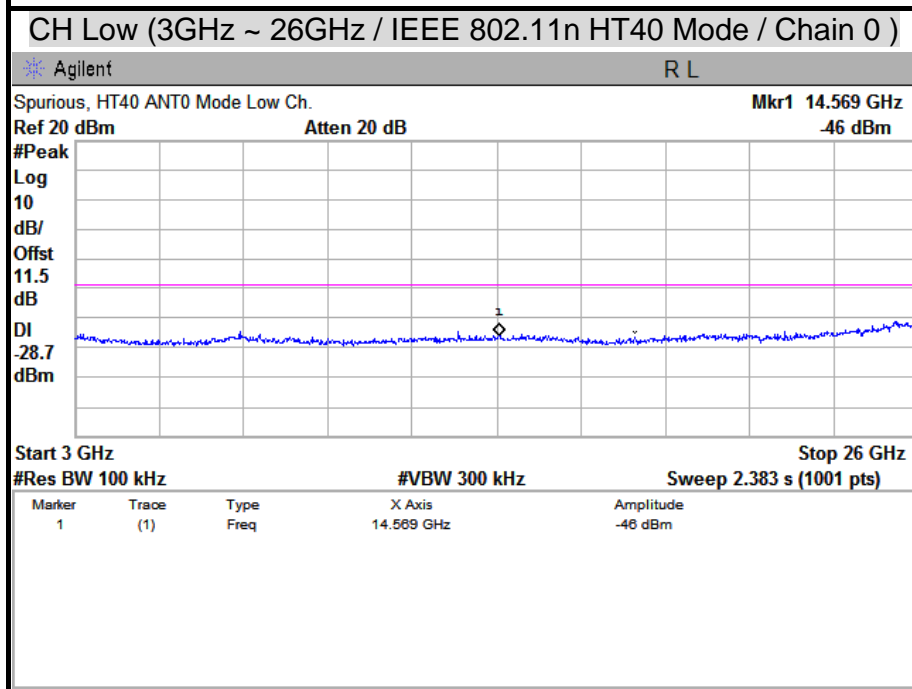
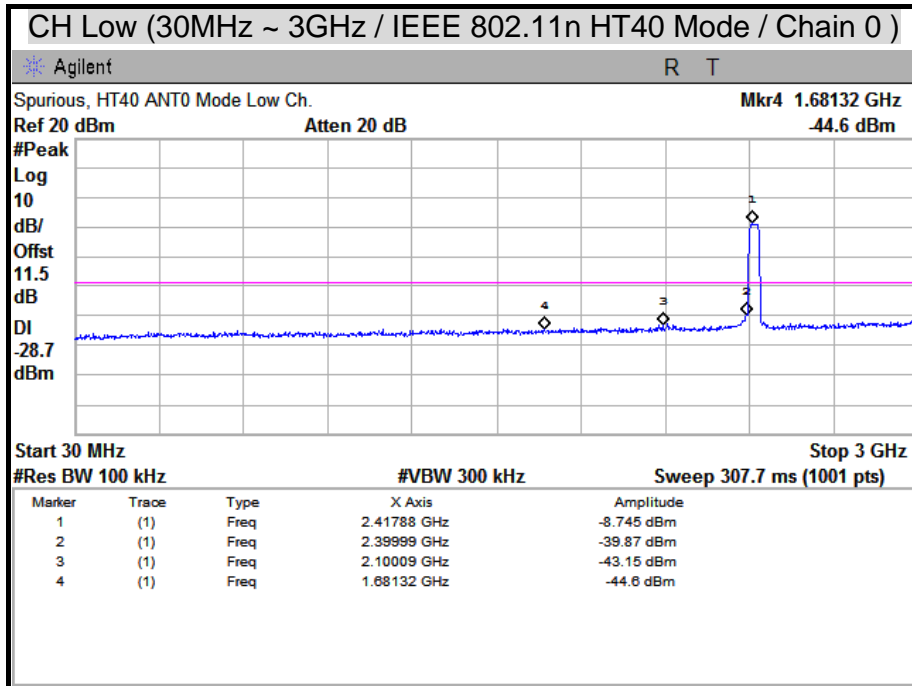

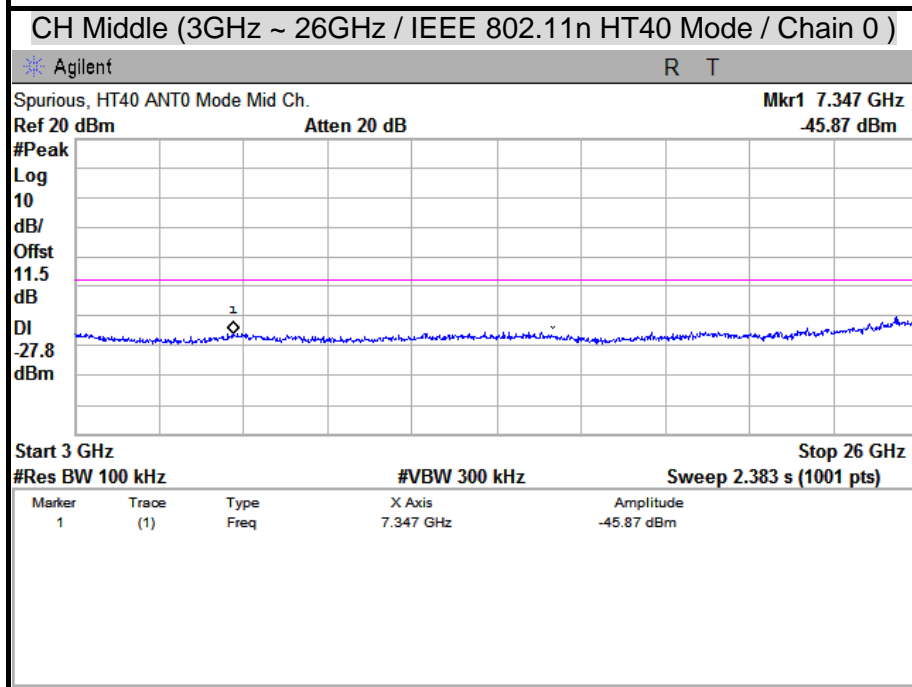
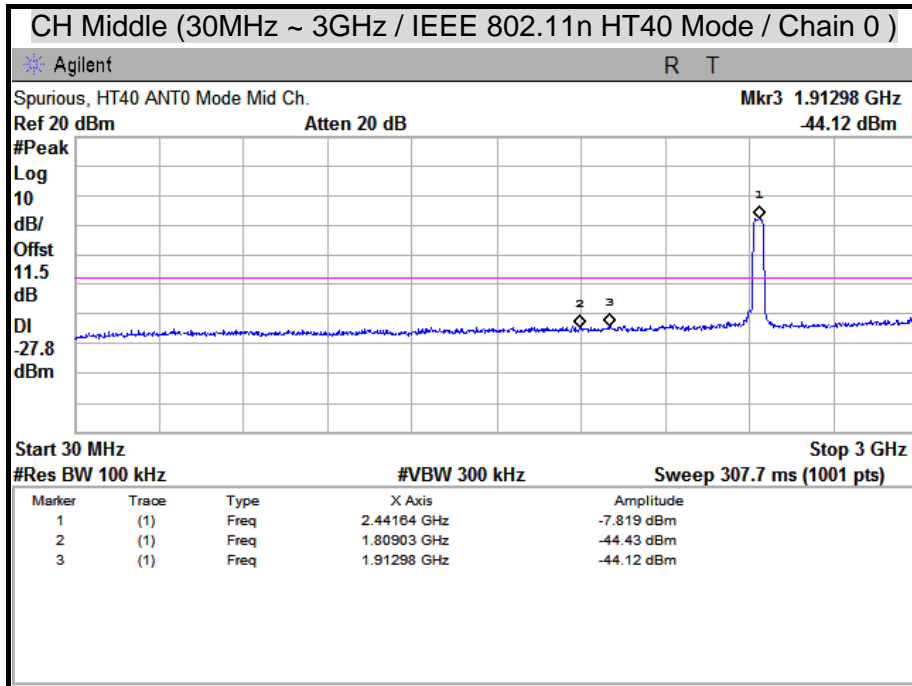

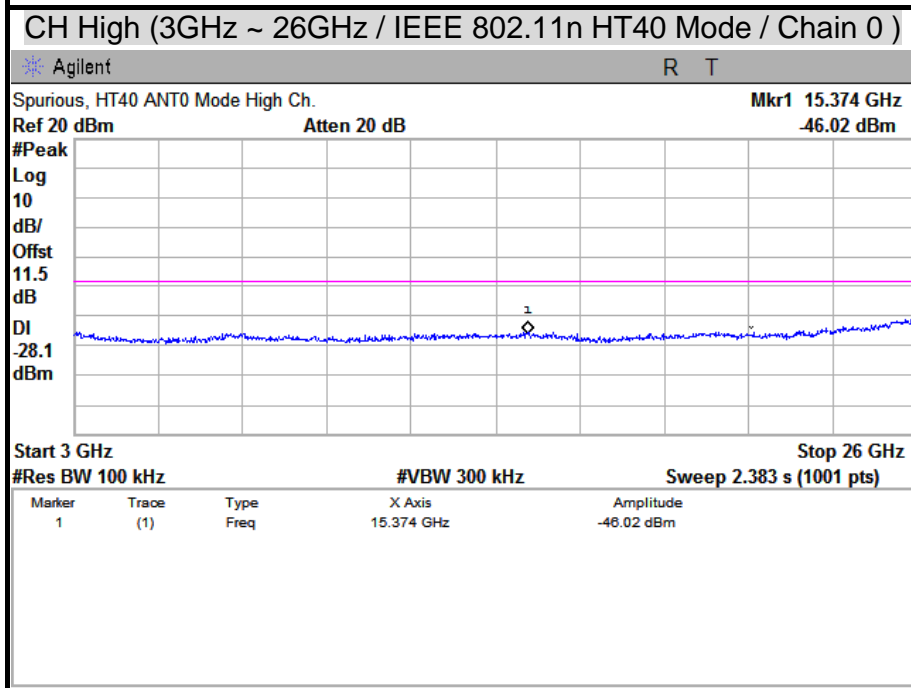
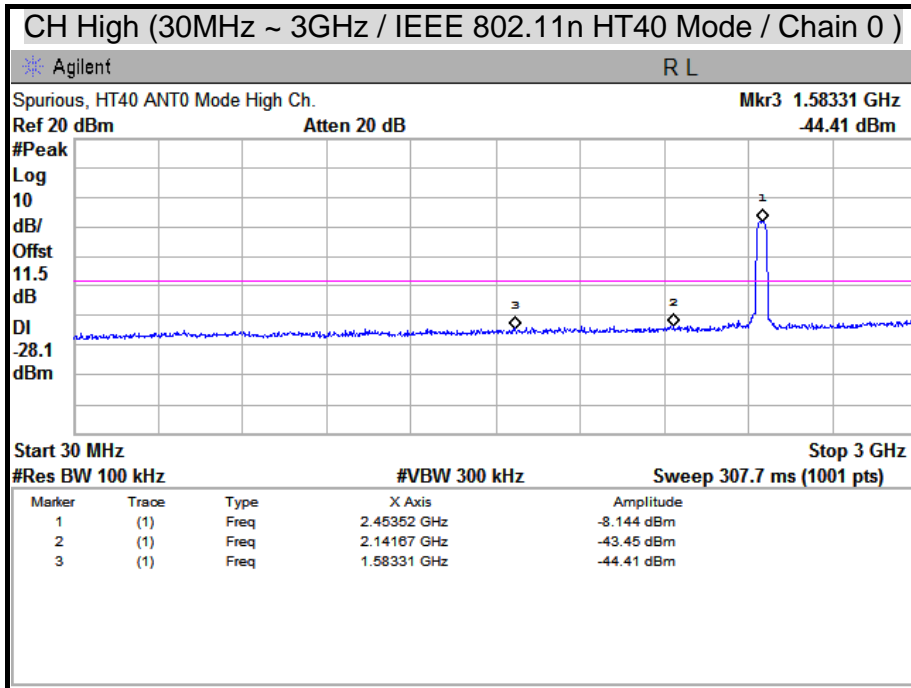

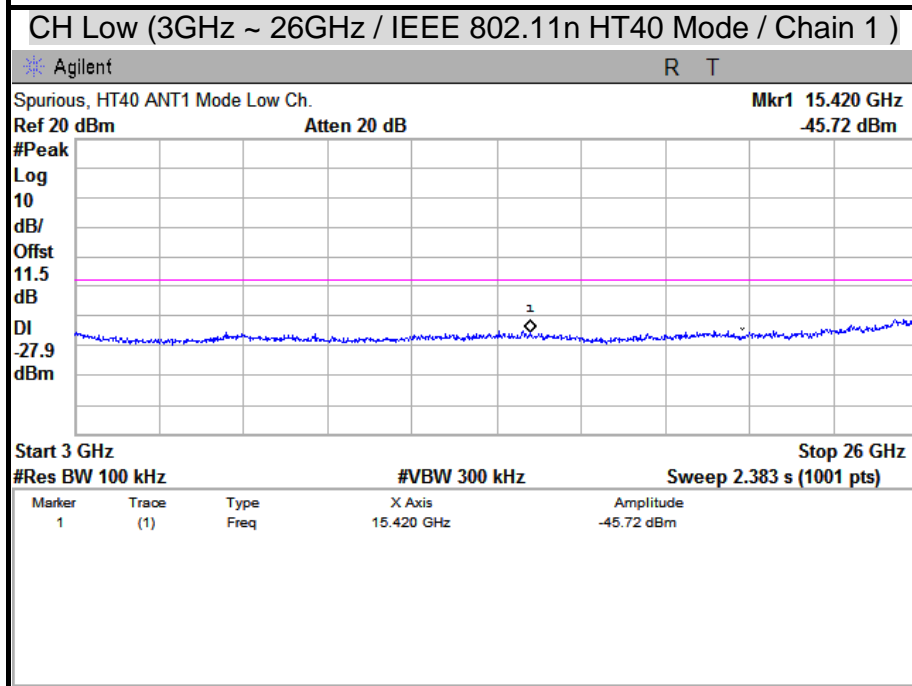
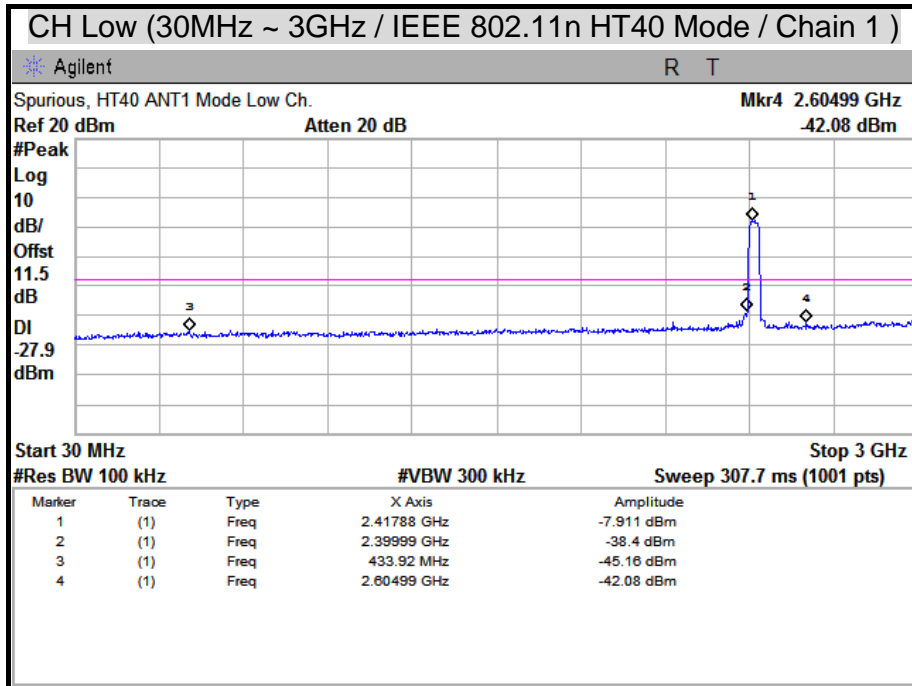

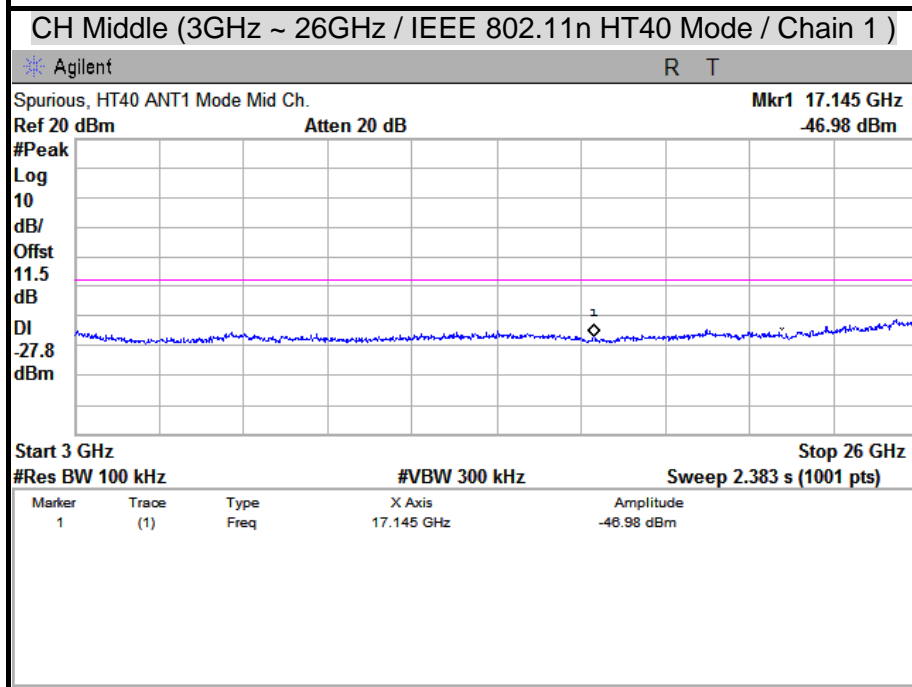
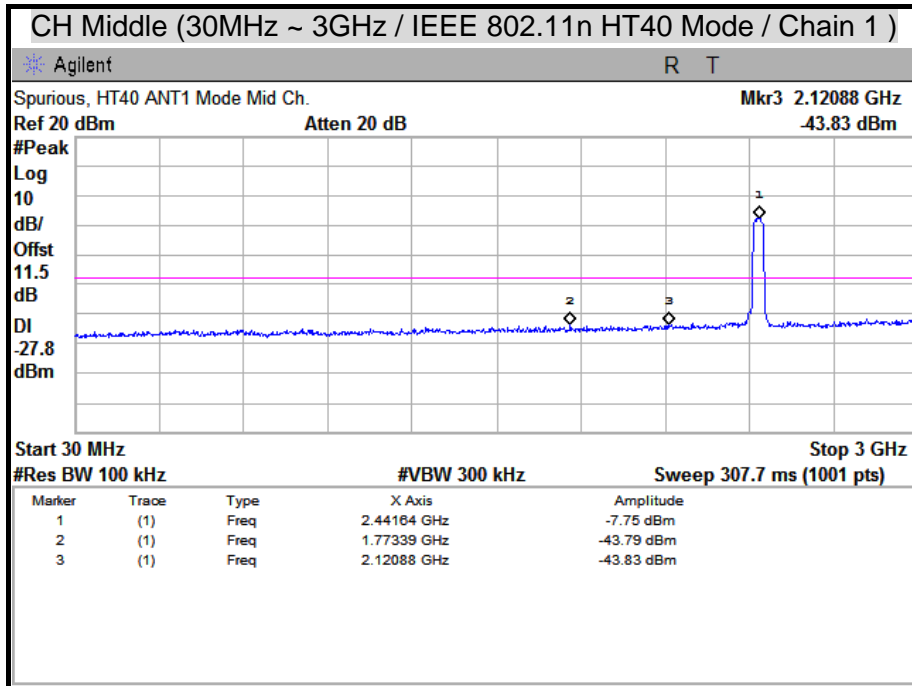

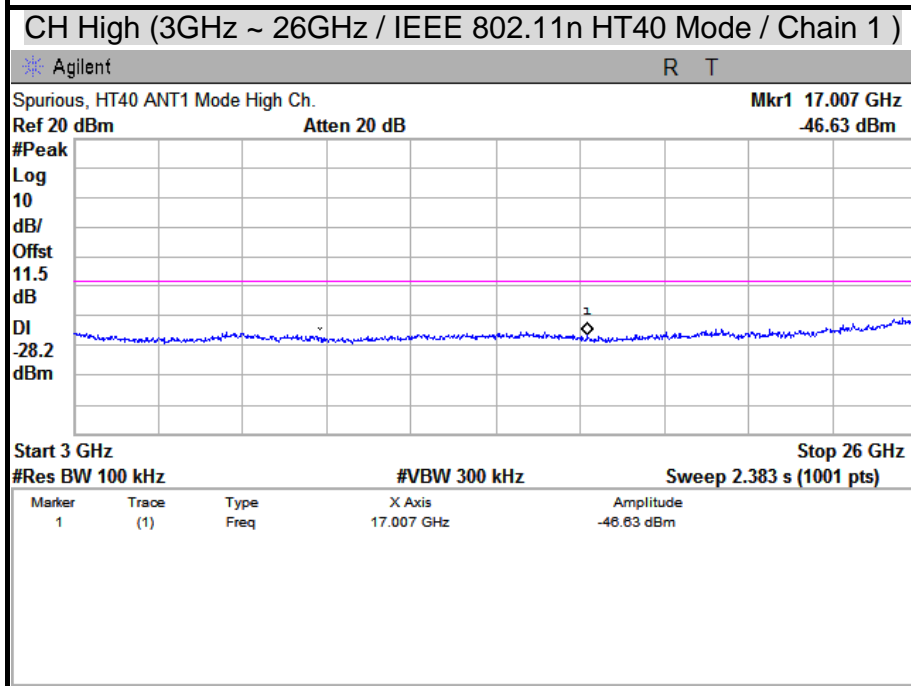
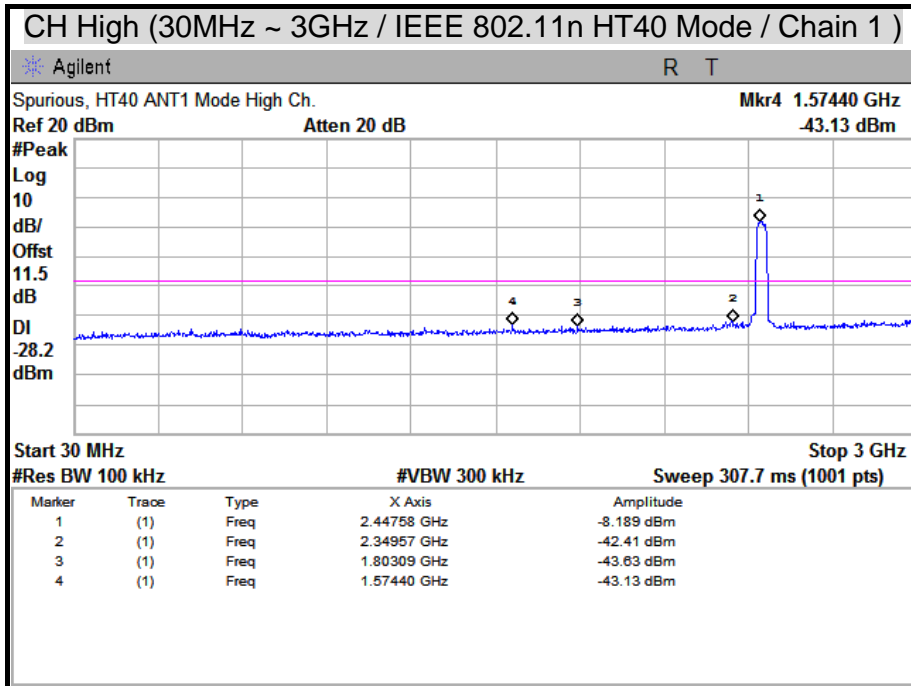



7.6 RADIATED EMISSION

LIMITS

(1) According to § 15.205 (a) Except as shown in paragraph (d) of this section, only spurious emissions are permitted in any of the frequency bands listed below:

MHz	MHz	MHz	GHz
0.090 - 0.110	16.42 - 16.423	399.9 - 410	4.5 - 5.15
¹ 0.495 - 0.505	16.69475 - 16.69525	608 - 614	5.35 - 5.46
2.1735 - 2.1905	16.80425 - 16.80475	960 - 1240	7.25 - 7.75
4.125 - 4.128	25.5 - 25.67	1300 - 1427	8.025 - 8.5
4.17725 - 4.17775	37.5 - 38.25	1435 - 1626.5	9.0 - 9.2
4.20725 - 4.20775	73 - 74.6	1645.5 - 1646.5	9.3 - 9.5
6.215 - 6.218	74.8 - 75.2	1660 - 1710	10.6 - 12.7
6.26775 - 6.26825	108 - 121.94	1718.8 - 1722.2	13.25 - 13.4
6.31175 - 6.31225	123 - 138	2200 - 2300	14.47 - 14.5
8.291 - 8.294	149.9 - 150.05	2310 - 2390	15.35 - 16.2
8.362 - 8.366	156.52475 - 156.52525	2483.5 - 2500	17.7 - 21.4
8.37625 - 8.38675	156.7 - 156.9	2655 - 2900	22.01 - 23.12
8.41425 - 8.41475	162.0125 - 167.17	3260 - 3267	23.6 - 24.0
12.29 - 12.293	167.72 - 173.2	3332 - 3339	31.2 - 31.8
12.51975 - 12.52025	240 - 285	3345.8 - 3338	36.43 - 36.5
12.57675 - 12.57725	322 - 335.4	3600 - 4400	(²)
13.36 - 13.41			

Remark:

1. ¹ Until February 1, 1999, this restricted band shall be 0.490-0.510 MHz.
2. ² Above 38.6

(2) According to § 15.205 (b) Except as provided in paragraphs (d) and (e), the field strength of emissions appearing within these frequency bands shall not exceed the limits shown in Section 15.209. At frequencies equal to or less than 1000 MHz, compliance with the limits in Section 15.209 shall be demonstrated using measurement instrumentation employing a CISPR quasi-peak detector. Above 1000 MHz, compliance with the emission limits in Section 15.209 shall be demonstrated based on the average value of the measured emissions. The provisions in Section 15.35 apply to these measurements.



(3) According to § 15.209 (a) Except as provided elsewhere in this Subpart, the emissions from an intentional radiator shall not exceed the field strength levels specified in the following table :

Frequency (MHz)	Field Strength (microvolts/meter)	Measurement Distance (meters)
0.009 – 0.490	2400/F(KHz)	300
0.490 – 1.705	24000/F(KHz)	30
1.705 – 30.0	30	30
30 - 88	100 **	3
88 - 216	150 **	3
216 - 960	200 **	3
Above 960	500	3

Remark: **Except as provided in paragraph (g), fundamental emissions from intentional radiators operating under this Section shall not be located in the frequency bands 54-72 MHz, 76-88 MHz, 174-216 MHz or 470-806 MHz. However, operation within these frequency bands is permitted under other sections of this Part, e.g., Sections 15.231 and 15.241.

(4) According to § 15.209 (b) In the emission table above, the tighter limit applies at the band edges.

TEST EQUIPMENT

Radiated Emission / 966Chamber_B

Name of Equipment	Manufacture	Model	Serial Number	Calibration Due
Spectrum Analyzer	Agilent	E4446A	MY43360132	06/19/2012
EMI Receiver	ROHDE & SCHWARZ	ESCI	101131	01/13/2012
Broadband Hybrid Bi-Log Antenna	Sunol Sciences	JB1	A100209-4	10/05/2012
Double-Ridged Waveguide Horn	ETS-LINDGREN	3117	00078732	07/03/2012
Horn Antenna	COM-POWER	AH-840	03077	12/12/2011
Pre-Amplifier	Agilent	8447D	2944A10052	07/19/2012
Pre-Amplifier	Agilent	8449B	3008A01916	09/18/2012
Notch Filters Band Reject	Micro-Tronics	BRM05702-01	026	N.C.R

Remark: 1. Each piece of equipment is scheduled for calibration once a year.
2. N.C.R = No Calibration Request.



TEST SETUP

The diagram below shows the test setup that is utilized to make the measurements for emission from below 1GHz.

9kHz ~ 30MHz

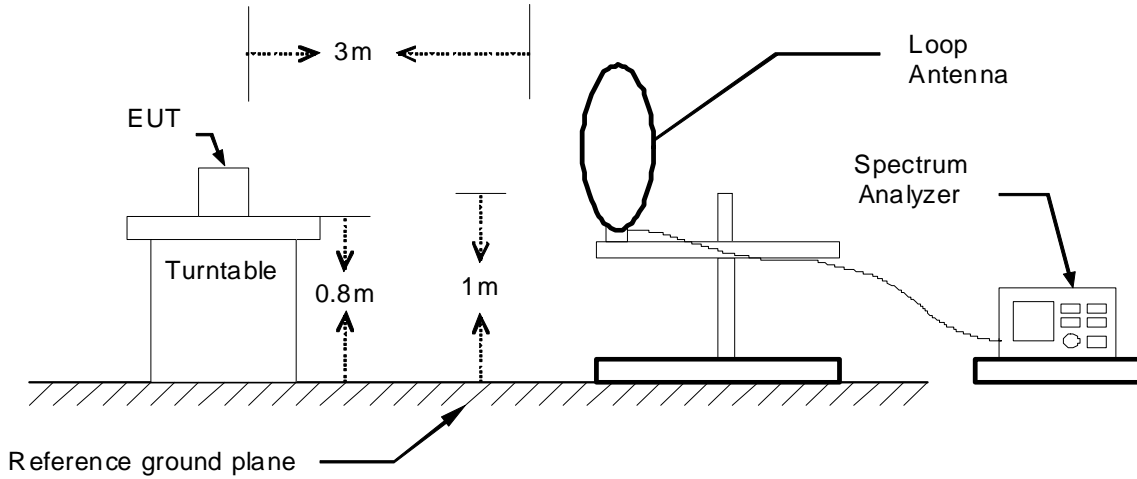

30MHz ~ 1GHz

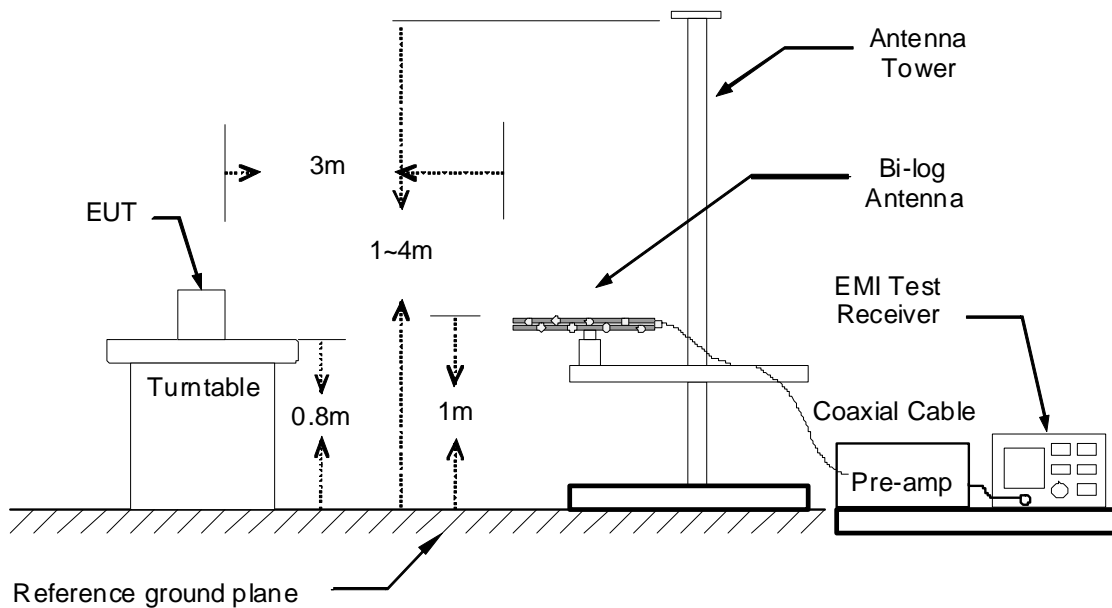



The diagram below shows the test setup that is utilized to make the measurements for emission above 1GHz.

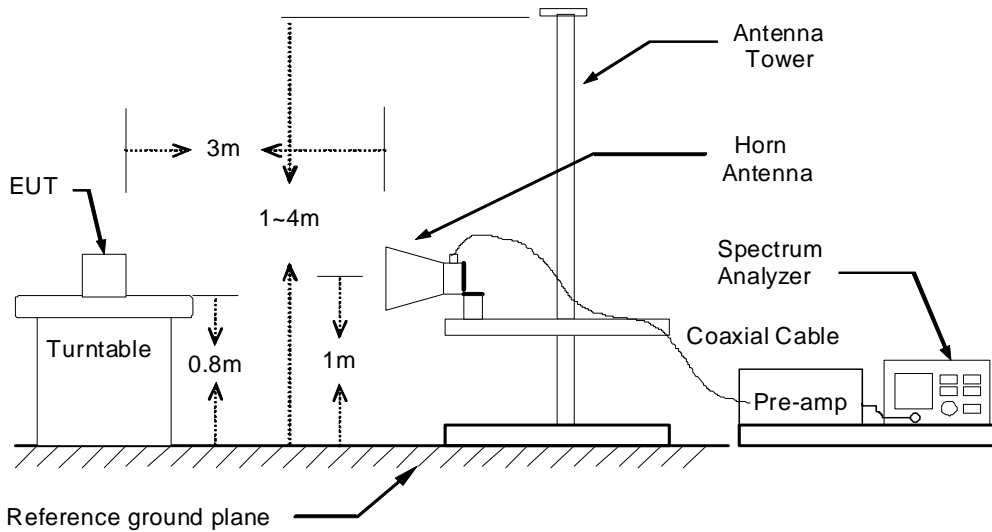

TEST PROCEDURE

1. The EUT was placed on the top of a rotating table 0.8 meters above the ground. The table was rotated 360 degrees to determine the position of the highest radiation.
2. While measuring the radiated emission below 1GHz, the EUT was set 3 meters away from the interference-receiving antenna, which was mounted on the top of a variable-height antenna tower. While measuring the radiated emission above 1GHz, the EUT was set 3 meters away from the interference-receiving antenna.
3. The antenna is a broadband antenna, and its height is varied from one meter to four meters above the ground to determine the maximum value of the field strength. Both horizontal and vertical polarization of the antenna are set to make the measurement.
4. For each suspected emission, the EUT was arranged to its worst case and then the antenna was tuned to heights from 1 meter to 4 meters and the table was turned from 0 degrees to 360 degrees to find the maximum reading.
5. The test-receiver system was set to Peak Detect Function and Specified Bandwidth with Maximum Hold Mode.
6. If the emission level of the EUT in peak mode was 10 dB lower than the limit specified, then testing could be stopped and the peak values of the EUT would be reported. Otherwise the emissions that did not have 10 dB margin would be re-tested one by one using peak, quasi-peak or average method as specified and then reported in a data sheet.

Remark :

1. The resolution bandwidth and video bandwidth of test receiver/spectrum analyzer is 120 KHz for Peak detection (PK) and Quasi-peak detection (QP) at frequency below 1GHz.
2. The resolution bandwidth and video bandwidth of test receiver/spectrum analyzer is 1 MHz for Peak detection and frequency above 1GHz.
3. The resolution bandwidth of test receiver/spectrum analyzer is 1 MHz and the video bandwidth is 10 Hz for Average detection (AV) at frequency above 1GHz.



TEST RESULTS

Below 1 GHz (9kHz ~ 30MHz)

No emission found between lowest internal used/generated frequency to 30MHz.

Below 1 GHz (30MHz ~ 1GHz)

Product Name	8x4 D3 Wireless Router	Test By	Waternil Guan
Test Model	CGN2-ROG01129	Test Date	2011/11/29
Test Mode	Normal Operating	Temp. & Humidity	22°C, 60%

966 Chamber_B at 3Meter / Horizontal						
Frequency (MHz)	Reading (dBµV)	Correction Factor (dB/m)	Result (dBµV/m)	Limit (dBµV/m)	Margin (dB)	Remark
125.06	49.35	-13.58	35.77	43.50	-7.73	Peak
250.19	59.06	-13.57	45.49	46.00	-0.51	QP
273.47	52.60	-12.38	40.22	46.00	-5.78	QP
375.32	55.90	-10.40	45.50	46.00	-0.50	QP
500.45	49.40	-8.24	41.16	46.00	-4.84	Peak
624.61	47.71	-6.43	41.28	46.00	-4.72	Peak
749.74	42.68	-4.68	37.99	46.00	-8.01	Peak
874.87	46.49	-2.59	43.90	46.00	-2.10	Peak

966 Chamber_B at 3Meter / Vertical						
Frequency (MHz)	Reading (dBµV)	Correction Factor (dB/m)	Result (dBµV/m)	Limit (dBµV/m)	Margin (dB)	Remark
51.34	56.90	-19.74	37.16	40.00	-2.84	QP
125.06	54.22	-13.58	40.64	43.50	-2.86	Peak
144.46	56.70	-13.71	42.99	43.50	-0.51	QP
250.19	58.02	-13.57	44.45	46.00	-1.55	Peak
288.02	52.66	-11.92	40.74	46.00	-5.26	Peak
375.32	53.60	-10.40	43.19	46.00	-2.81	Peak
500.45	43.28	-8.24	35.04	46.00	-10.96	Peak
624.61	44.34	-6.43	37.92	46.00	-8.08	Peak
749.74	41.78	-4.68	37.10	46.00	-8.90	Peak
874.87	40.10	-2.59	37.52	46.00	-8.48	Peak

Remark:

1. Quasi-peak test would be performed if the peak result were greater than the quasi-peak limit.
2. Data of measurement within this frequency range shown " --- " in the table above means the reading of emissions are attenuated more than 20dB below the permissible limits or the field strength is too small to be measured.
3. Correction Factor (dB/m) = Antenna Factor (dB/m) + Cable Loss (dB) – PreAmp.Gain (dB)
4. Result (dBuV/m) = Reading (dBuV) + Correction Factor (dB/m)
5. Margin (dB) = Remark result (dBuV/m) - Quasi-peak limit (dBuV/m).



Above 1 GHz

Product Name	8x4 D3 Wireless Router	Test By	Waternil Guan
Test Model	CGN2-ROG01129	Test Date	2011/09/08
Test Mode	IEEE 802.11b TX / CH Low	TEMP & Humidity	24°C, 57%

966 Chamber_B at 3Meter / Horizontal									
Frequency (MHz)	Reading-PK (dBuV)	Reading-AV (dBuV)	Correction Factor (dB/m)	Result-PK (dBuV/m)	Result-AV (dBuV/m)	Limit-PK (dBuV/m)	Limit-AV (dBuV/m)	Margin (dB)	Remark
1126.00	50.74	---	-4.61	46.13	---	74.00	54.00	-7.87	Peak
1250.00	46.33	---	-4.18	42.14	---	74.00	54.00	-11.86	Peak
1800.00	48.18	---	-0.41	47.77	---	74.00	54.00	-6.23	Peak
2412.00	93.73	---	2.58	96.31	---	---	---	---	Fundamental
3405.00	43.30	---	4.77	48.07	---	74.00	54.00	-5.93	Peak
3780.00	42.46	---	5.37	47.83	---	74.00	54.00	-6.17	Peak
4785.00	40.42	---	8.06	48.48	---	74.00	54.00	-5.52	Peak

966 Chamber_B at 3Meter / Vertical									
Frequency (MHz)	Reading-PK (dBuV)	Reading-AV (dBuV)	Correction Factor (dB/m)	Result-PK (dBuV/m)	Result-AV (dBuV/m)	Limit-PK (dBuV/m)	Limit-AV (dBuV/m)	Margin (dB)	Remark
1126.00	49.11	---	-4.61	44.50	---	74.00	54.00	-9.50	Peak
1400.00	47.26	---	-3.67	43.60	---	74.00	54.00	-10.40	Peak
1800.00	48.07	---	-0.41	47.66	---	74.00	54.00	-6.34	Peak
2412.00	87.56	---	2.57	90.13	---	---	---	---	Fundamental
3210.00	46.06	---	4.93	51.00	---	74.00	54.00	-3.00	Peak
3795.00	42.69	---	5.41	48.09	---	74.00	54.00	-5.91	Peak
4830.00	49.47	44.42	8.09	57.56	52.51	74.00	54.00	-1.49	AVG

Remark:

1. Measuring frequencies from 1 GHz to the 10th harmonic of highest fundamental frequency.
2. Average test would be performed if the peak result were greater than the average limit.
3. Data of measurement within this frequency range shown " --- " in the table above means the reading of emissions are attenuated more than 20dB below the permissible limits or the field strength is too small to be measured.
4. Measurements above show only up to 6 maximum emissions noted, or would be lesser, with " N/A " remark, if no specific emissions from the EUT are recorded (ie: margin>20dB from the applicable limit) and considered that's already beyond the background noise floor.
5. In any 100 kHz bandwidth outside the frequency band in which the spread spectrum or digitally modulated intentional radiator is operating, the radio frequency power that is produced by the intentional radiator shall be at least 20 dB below that in the 100 kHz bandwidth within the band that contains the highest level of the desired power, based on either an RF conducted or a radiated measurement, provided the transmitter demonstrates compliance with the peak conducted power limits. If the transmitter complies with the conducted power limits based on the use of RMS averaging over a time interval, as permitted under paragraph (b)(3) of this section, the attenuation required under this paragraph shall be 30 dB instead of 20 dB.
6. Result = Reading + Correction Factor
Margin = Result – Limit
Remark Peak = Result(PK) – Limit(AV)
Remark AVG = Result(AV) – Limit(AV)



Product Name	8x4 D3 Wireless Router	Test By	Waternil Guan
Test Model	CGN2-ROG01129	Test Date	2011/09/08
Test Mode	IEEE 802.11b TX / CH Middle	TEMP & Humidity	24°C, 57%

966 Chamber_B at 3Meter / Horizontal									
Frequency (MHz)	Reading-PK (dBuV)	Reading-AV (dBuV)	Correction Factor (dB/m)	Result-PK (dBuV/m)	Result-AV (dBuV/m)	Limit-PK (dBuV/m)	Limit-AV (dBuV/m)	Margin (dB)	Remark
1124.00	52.20	---	-4.62	47.58	---	74.00	54.00	-6.42	Peak
1250.00	47.52	---	-4.18	43.34	---	74.00	54.00	-10.66	Peak
1800.00	49.55	---	-0.41	49.14	---	74.00	54.00	-4.86	Peak
2437.00	91.84	---	2.64	94.48	---	---	---	---	Fundamental
3105.00	43.38	---	5.02	48.40	---	74.00	54.00	-5.60	Peak
4305.00	41.34	---	7.11	48.45	---	74.00	54.00	-5.55	Peak
4875.00	41.31	---	8.12	49.43	---	74.00	54.00	-4.57	Peak

966 Chamber_B at 3Meter / Vertical									
Frequency (MHz)	Reading-PK (dBuV)	Reading-AV (dBuV)	Correction Factor (dB/m)	Result-PK (dBuV/m)	Result-AV (dBuV/m)	Limit-PK (dBuV/m)	Limit-AV (dBuV/m)	Margin (dB)	Remark
1126.00	49.26	---	-4.61	44.64	---	74.00	54.00	-9.36	Peak
1478.00	46.46	---	-3.40	43.06	---	74.00	54.00	-10.94	Peak
1792.00	46.15	---	-0.49	45.67	---	74.00	54.00	-8.33	Peak
2437.00	87.61	---	2.64	90.24	---	---	---	---	Fundamental
3255.00	44.24	---	4.90	49.13	---	74.00	54.00	-4.87	Peak
4185.00	41.25	---	6.64	47.89	---	74.00	54.00	-6.11	Peak
4875.00	49.23	44.47	8.12	57.35	52.59	74.00	54.00	-1.41	AVG

Remark:

1. Measuring frequencies from 1 GHz to the 10th harmonic of highest fundamental frequency.
2. Average test would be performed if the peak result were greater than the average limit.
3. Data of measurement within this frequency range shown " --- " in the table above means the reading of emissions are attenuated more than 20dB below the permissible limits or the field strength is too small to be measured.
4. Measurements above show only up to 6 maximum emissions noted, or would be lesser, with " N/A " remark, if no specific emissions from the EUT are recorded (ie: margin>20dB from the applicable limit) and considered that's already beyond the background noise floor.
5. In any 100 kHz bandwidth outside the frequency band in which the spread spectrum or digitally modulated intentional radiator is operating, the radio frequency power that is produced by the intentional radiator shall be at least 20 dB below that in the 100 kHz bandwidth within the band that contains the highest level of the desired power, based on either an RF conducted or a radiated measurement, provided the transmitter demonstrates compliance with the peak conducted power limits. If the transmitter complies with the conducted power limits based on the use of RMS averaging over a time interval, as permitted under paragraph (b)(3) of this section, the attenuation required under this paragraph shall be 30 dB instead of 20 dB.
6. Result = Reading + Correction Factor
Margin = Result - Limit
Remark Peak = Result(PK) - Limit(AV)
Remark AVG = Result(AV) - Limit(AV)



Product Name	8x4 D3 Wireless Router	Test By	Waternil Guan
Test Model	CGN2-ROG01129	Test Date	2011/09/08
Test Mode	IEEE 802.11b TX / CH High	TEMP & Humidity	24°C, 57%

966 Chamber_B at 3Meter / Horizontal									
Frequency (MHz)	Reading-PK (dBuV)	Reading-AV (dBuV)	Correction Factor (dB/m)	Result-PK (dBuV/m)	Result-AV (dBuV/m)	Limit-PK (dBuV/m)	Limit-AV (dBuV/m)	Margin (dB)	Remark
1126.00	51.29	---	-4.61	46.68	---	74.00	54.00	-7.32	Peak
1760.00	45.38	---	-0.80	44.58	---	74.00	54.00	-9.42	Peak
1800.00	49.61	---	-0.41	49.20	---	74.00	54.00	-4.80	Peak
2462.00	92.27	---	2.70	94.97	---	---	---	---	Fundamental
3135.00	43.95	---	5.00	48.95	---	74.00	54.00	-5.05	Peak
4110.00	42.39	---	6.34	48.73	---	74.00	54.00	-5.27	Peak
4935.00	40.93	---	8.16	49.09	---	74.00	54.00	-4.91	Peak

966 Chamber_B at 3Meter / Vertical									
Frequency (MHz)	Reading-PK (dBuV)	Reading-AV (dBuV)	Correction Factor (dB/m)	Result-PK (dBuV/m)	Result-AV (dBuV/m)	Limit-PK (dBuV/m)	Limit-AV (dBuV/m)	Margin (dB)	Remark
1124.00	49.44	---	-4.62	44.81	---	74.00	54.00	-9.19	Peak
1376.00	46.74	---	-3.75	42.99	---	74.00	54.00	-11.01	Peak
1800.00	46.73	---	-0.41	46.32	---	74.00	54.00	-7.68	Peak
2462.00	88.12	---	2.70	90.82	---	---	---	---	Fundamental
3285.00	44.78	---	4.87	49.65	---	74.00	54.00	-4.35	Peak
4462.50	41.50	---	7.73	49.23	---	74.00	54.00	-4.77	Peak
4927.50	47.12	44.17	8.15	55.27	52.32	74.00	54.00	-1.68	AVG

Remark:

1. Measuring frequencies from 1 GHz to the 10th harmonic of highest fundamental frequency.
2. Average test would be performed if the peak result were greater than the average limit.
3. Data of measurement within this frequency range shown " --- " in the table above means the reading of emissions are attenuated more than 20dB below the permissible limits or the field strength is too small to be measured.
4. Measurements above show only up to 6 maximum emissions noted, or would be lesser, with " N/A " remark, if no specific emissions from the EUT are recorded (ie: margin>20dB from the applicable limit) and considered that's already beyond the background noise floor.
5. In any 100 kHz bandwidth outside the frequency band in which the spread spectrum or digitally modulated intentional radiator is operating, the radio frequency power that is produced by the intentional radiator shall be at least 20 dB below that in the 100 kHz bandwidth within the band that contains the highest level of the desired power, based on either an RF conducted or a radiated measurement, provided the transmitter demonstrates compliance with the peak conducted power limits. If the transmitter complies with the conducted power limits based on the use of RMS averaging over a time interval, as permitted under paragraph (b)(3) of this section, the attenuation required under this paragraph shall be 30 dB instead of 20 dB.
6. Result = Reading + Correction Factor
Margin = Result - Limit
Remark Peak = Result(PK) - Limit(AV)
Remark AVG = Result(AV) - Limit(AV)



Product Name	8x4 D3 Wireless Router	Test By	Waternil Guan
Test Model	CGN2-ROG01129	Test Date	2011/09/08
Test Mode	IEEE 802.11g TX / CH Low	TEMP & Humidity	24°C, 57%

966 Chamber_B at 3Meter / Horizontal									
Frequency (MHz)	Reading-PK (dBuV)	Reading-AV (dBuV)	Correction Factor (dB/m)	Result-PK (dBuV/m)	Result-AV (dBuV/m)	Limit-PK (dBuV/m)	Limit-AV (dBuV/m)	Margin (dB)	Remark
1080.00	48.40	---	-4.77	43.63	---	74.00	54.00	-10.37	Peak
1126.00	51.42	---	-4.61	46.81	---	74.00	54.00	-7.19	Peak
1800.00	48.01	---	-0.41	47.60	---	74.00	54.00	-6.40	Peak
2412.00	96.00	---	2.57	98.57	---	---	---	---	Fundamental
3210.00	43.78	---	4.93	48.71	---	74.00	54.00	-5.29	Peak
4485.00	41.72	---	7.82	49.54	---	74.00	54.00	-4.46	Peak
4830.00	43.28	---	8.09	51.37	---	74.00	54.00	-2.63	Peak

966 Chamber_B at 3Meter / Vertical									
Frequency (MHz)	Reading-PK (dBuV)	Reading-AV (dBuV)	Correction Factor (dB/m)	Result-PK (dBuV/m)	Result-AV (dBuV/m)	Limit-PK (dBuV/m)	Limit-AV (dBuV/m)	Margin (dB)	Remark
1126.00	49.54	---	-4.61	44.93	---	74.00	54.00	-9.07	Peak
1374.00	47.21	---	-3.76	43.45	---	74.00	54.00	-10.55	Peak
1800.00	46.74	---	-0.41	46.33	---	74.00	54.00	-7.67	Peak
2412.00	91.49	---	2.57	94.06	---	---	---	---	Fundamental
3210.00	45.37	---	4.93	50.31	---	74.00	54.00	-3.69	Peak
4575.00	41.42	---	7.93	49.35	---	74.00	54.00	-4.65	Peak
4830.00	58.27	44.27	8.09	66.36	52.36	74.00	54.00	-1.64	AVG

Remark:

1. Measuring frequencies from 1 GHz to the 10th harmonic of highest fundamental frequency.
2. Average test would be performed if the peak result were greater than the average limit.
3. Data of measurement within this frequency range shown " --- " in the table above means the reading of emissions are attenuated more than 20dB below the permissible limits or the field strength is too small to be measured.
4. Measurements above show only up to 6 maximum emissions noted, or would be lesser, with " N/A " remark, if no specific emissions from the EUT are recorded (ie: margin>20dB from the applicable limit) and considered that's already beyond the background noise floor.
5. In any 100 kHz bandwidth outside the frequency band in which the spread spectrum or digitally modulated intentional radiator is operating, the radio frequency power that is produced by the intentional radiator shall be at least 20 dB below that in the 100 kHz bandwidth within the band that contains the highest level of the desired power, based on either an RF conducted or a radiated measurement, provided the transmitter demonstrates compliance with the peak conducted power limits. If the transmitter complies with the conducted power limits based on the use of RMS averaging over a time interval, as permitted under paragraph (b)(3) of this section, the attenuation required under this paragraph shall be 30 dB instead of 20 dB.
6. Result = Reading + Correction Factor
Margin = Result - Limit
Remark Peak = Result(PK) - Limit(AV)
Remark AVG = Result(AV) - Limit(AV)



Product Name	8x4 D3 Wireless Router	Test By	Waternil Guan
Test Model	CGN2-ROG01129	Test Date	2011/09/08
Test Mode	IEEE 802.11g TX / CH Middle	TEMP & Humidity	24°C, 57%

966 Chamber_B at 3Meter / Horizontal									
Frequency (MHz)	Reading-PK (dBuV)	Reading-AV (dBuV)	Correction Factor (dB/m)	Result-PK (dBuV/m)	Result-AV (dBuV/m)	Limit-PK (dBuV/m)	Limit-AV (dBuV/m)	Margin (dB)	Remark
1126.00	52.06	---	-4.61	47.44	---	74.00	54.00	-6.56	Peak
1636.00	45.02	---	-2.00	43.02	---	74.00	54.00	-10.98	Peak
1800.00	51.17	---	-0.41	50.76	---	74.00	54.00	-3.24	Peak
2437.00	96.02	---	2.64	98.65	---	---	---	---	Fundamental
3045.00	43.64	---	5.07	48.72	---	74.00	54.00	-5.28	Peak
4485.00	41.57	---	7.82	49.39	---	74.00	54.00	-4.61	Peak
4875.00	44.14	---	8.12	52.26	---	74.00	54.00	-1.74	Peak

966 Chamber_B at 3Meter / Vertical									
Frequency (MHz)	Reading-PK (dBuV)	Reading-AV (dBuV)	Correction Factor (dB/m)	Result-PK (dBuV/m)	Result-AV (dBuV/m)	Limit-PK (dBuV/m)	Limit-AV (dBuV/m)	Margin (dB)	Remark
1124.00	49.05	---	-4.62	44.43	---	74.00	54.00	-9.57	Peak
1400.00	47.92	---	-3.67	44.25	---	74.00	54.00	-9.75	Peak
1800.00	46.73	---	-0.41	46.32	---	74.00	54.00	-7.68	Peak
2437.00	91.43	---	2.64	94.08	---	---	---	---	Fundamental
3255.00	44.49	---	4.90	49.39	---	74.00	54.00	-4.61	Peak
4500.00	41.95	---	7.88	49.83	---	74.00	54.00	-4.17	Peak
4875.00	56.82	44.64	8.12	64.94	52.76	74.00	54.00	-1.24	AVG

Remark:

1. Measuring frequencies from 1 GHz to the 10th harmonic of highest fundamental frequency.
2. Average test would be performed if the peak result were greater than the average limit.
3. Data of measurement within this frequency range shown " --- " in the table above means the reading of emissions are attenuated more than 20dB below the permissible limits or the field strength is too small to be measured.
4. Measurements above show only up to 6 maximum emissions noted, or would be lesser, with " N/A " remark, if no specific emissions from the EUT are recorded (ie: margin>20dB from the applicable limit) and considered that's already beyond the background noise floor.
5. In any 100 kHz bandwidth outside the frequency band in which the spread spectrum or digitally modulated intentional radiator is operating, the radio frequency power that is produced by the intentional radiator shall be at least 20 dB below that in the 100 kHz bandwidth within the band that contains the highest level of the desired power, based on either an RF conducted or a radiated measurement, provided the transmitter demonstrates compliance with the peak conducted power limits. If the transmitter complies with the conducted power limits based on the use of RMS averaging over a time interval, as permitted under paragraph (b)(3) of this section, the attenuation required under this paragraph shall be 30 dB instead of 20 dB.
6. Result = Reading + Correction Factor
Margin = Result - Limit
Remark Peak = Result(PK) - Limit(AV)
Remark AVG = Result(AV) - Limit(AV)



Product Name	8x4 D3 Wireless Router	Test By	Waternil Guan
Test Model	CGN2-ROG01129	Test Date	2011/09/08
Test Mode	IEEE 802.11g TX / CH High	TEMP & Humidity	24°C, 57%

966 Chamber_B at 3Meter / Horizontal									
Frequency (MHz)	Reading-PK (dBuV)	Reading-AV (dBuV)	Correction Factor (dB/m)	Result-PK (dBuV/m)	Result-AV (dBuV/m)	Limit-PK (dBuV/m)	Limit-AV (dBuV/m)	Margin (dB)	Remark
1126.00	52.04	---	-4.61	47.42	---	74.00	54.00	-6.58	Peak
1760.00	46.34	---	-0.80	45.54	---	74.00	54.00	-8.46	Peak
1800.00	48.54	---	-0.41	48.13	---	74.00	54.00	-5.87	Peak
2462.00	96.33	---	2.70	99.02	---	---	---	---	Fundamental
3150.00	43.53	---	4.98	48.52	---	74.00	54.00	-5.48	Peak
4425.00	42.57	---	7.58	50.15	---	74.00	54.00	-3.85	Peak
4920.00	44.52	---	8.15	52.67	---	74.00	54.00	-1.33	Peak

966 Chamber_B at 3Meter / Vertical									
Frequency (MHz)	Reading-PK (dBuV)	Reading-AV (dBuV)	Correction Factor (dB/m)	Result-PK (dBuV/m)	Result-AV (dBuV/m)	Limit-PK (dBuV/m)	Limit-AV (dBuV/m)	Margin (dB)	Remark
1124.00	49.40	---	-4.62	44.78	---	74.00	54.00	-9.22	Peak
1376.00	46.56	---	-3.75	42.81	---	74.00	54.00	-11.19	Peak
1800.00	45.74	---	-0.41	45.33	---	74.00	54.00	-8.67	Peak
2462.00	91.68	---	2.70	94.38	---	---	---	---	Fundamental
3285.00	45.48	---	4.87	50.35	---	74.00	54.00	-3.65	Peak
4155.00	41.69	---	6.52	48.21	---	74.00	54.00	-5.79	Peak
4920.00	57.03	44.31	8.15	65.18	52.46	74.00	54.00	-1.54	AVG

Remark:

1. Measuring frequencies from 1 GHz to the 10th harmonic of highest fundamental frequency.
2. Average test would be performed if the peak result were greater than the average limit.
3. Data of measurement within this frequency range shown " --- " in the table above means the reading of emissions are attenuated more than 20dB below the permissible limits or the field strength is too small to be measured.
4. Measurements above show only up to 6 maximum emissions noted, or would be lesser, with " N/A " remark, if no specific emissions from the EUT are recorded (ie: margin>20dB from the applicable limit) and considered that's already beyond the background noise floor.
5. In any 100 kHz bandwidth outside the frequency band in which the spread spectrum or digitally modulated intentional radiator is operating, the radio frequency power that is produced by the intentional radiator shall be at least 20 dB below that in the 100 kHz bandwidth within the band that contains the highest level of the desired power, based on either an RF conducted or a radiated measurement, provided the transmitter demonstrates compliance with the peak conducted power limits. If the transmitter complies with the conducted power limits based on the use of RMS averaging over a time interval, as permitted under paragraph (b)(3) of this section, the attenuation required under this paragraph shall be 30 dB instead of 20 dB.
6. Result = Reading + Correction Factor
Margin = Result - Limit
Remark Peak = Result(PK) - Limit(AV)
Remark AVG = Result(AV) - Limit(AV)



Product Name	8x4 D3 Wireless Router	Test By	Waternil Guan
Test Model	CGN2-ROG01129	Test Date	2011/09/08
Test Mode	IEEE 802.11n HT20 TX / CH Low	TEMP & Humidity	24°C, 57%

966 Chamber_B at 3Meter / Horizontal									
Frequency (MHz)	Reading-PK (dBuV)	Reading-AV (dBuV)	Correction Factor (dB/m)	Result-PK (dBuV/m)	Result-AV (dBuV/m)	Limit-PK (dBuV/m)	Limit-AV (dBuV/m)	Margin (dB)	Remark
1126.00	50.59	---	-4.61	45.97	---	74.00	54.00	-8.03	Peak
1760.00	46.93	---	-0.80	46.13	---	74.00	54.00	-7.87	Peak
1800.00	48.69	---	-0.41	48.28	---	74.00	54.00	-5.72	Peak
2412.00	100.87	---	2.59	103.45	---	---	---	---	Fundamental
3105.00	43.53	---	5.02	48.55	---	74.00	54.00	-5.45	Peak
4230.00	41.48	---	6.81	48.29	---	74.00	54.00	-5.71	Peak
4815.00	43.24	---	8.08	51.32	---	74.00	54.00	-2.68	Peak

966 Chamber_B at 3Meter / Vertical									
Frequency (MHz)	Reading-PK (dBuV)	Reading-AV (dBuV)	Correction Factor (dB/m)	Result-PK (dBuV/m)	Result-AV (dBuV/m)	Limit-PK (dBuV/m)	Limit-AV (dBuV/m)	Margin (dB)	Remark
1126.00	48.85	---	-4.61	44.24	---	74.00	54.00	-9.76	Peak
1374.00	46.35	---	-3.76	42.60	---	74.00	54.00	-11.40	Peak
1800.00	47.11	---	-0.41	46.70	---	74.00	54.00	-7.30	Peak
2412.00	95.54	---	2.58	98.11	---	---	---	---	Fundamental
3210.00	50.02	47.09	4.93	54.95	52.02	74.00	54.00	-1.98	AVG
4200.00	41.29	---	6.70	47.98	---	74.00	54.00	-6.02	Peak
4815.00	55.23	44.27	8.08	63.31	52.35	74.00	54.00	-1.65	AVG

Remark:

1. Measuring frequencies from 1 GHz to the 10th harmonic of highest fundamental frequency.
2. Average test would be performed if the peak result were greater than the average limit.
3. Data of measurement within this frequency range shown " --- " in the table above means the reading of emissions are attenuated more than 20dB below the permissible limits or the field strength is too small to be measured.
4. Measurements above show only up to 6 maximum emissions noted, or would be lesser, with " N/A " remark, if no specific emissions from the EUT are recorded (ie: margin>20dB from the applicable limit) and considered that's already beyond the background noise floor.
5. In any 100 kHz bandwidth outside the frequency band in which the spread spectrum or digitally modulated intentional radiator is operating, the radio frequency power that is produced by the intentional radiator shall be at least 20 dB below that in the 100 kHz bandwidth within the band that contains the highest level of the desired power, based on either an RF conducted or a radiated measurement, provided the transmitter demonstrates compliance with the peak conducted power limits. If the transmitter complies with the conducted power limits based on the use of RMS averaging over a time interval, as permitted under paragraph (b)(3) of this section, the attenuation required under this paragraph shall be 30 dB instead of 20 dB.
6. Result = Reading + Correction Factor
Margin = Result - Limit
Remark Peak = Result(PK) - Limit(AV)
Remark AVG = Result(AV) - Limit(AV)



Product Name	8x4 D3 Wireless Router	Test By	Waternil Guan
Test Model	CGN2-ROG01129	Test Date	2011/09/08
Test Mode	IEEE 802.11n HT20 TX / CH Middle	TEMP & Humidity	24°C, 57%

966 Chamber_B at 3Meter / Horizontal									
Frequency (MHz)	Reading-PK (dBuV)	Reading-AV (dBuV)	Correction Factor (dB/m)	Result-PK (dBuV/m)	Result-AV (dBuV/m)	Limit-PK (dBuV/m)	Limit-AV (dBuV/m)	Margin (dB)	Remark
1126.00	50.85	---	-4.61	46.23	---	74.00	54.00	-7.77	Peak
1760.00	46.37	---	-0.80	45.57	---	74.00	54.00	-8.43	Peak
1800.00	49.21	---	-0.41	48.80	---	74.00	54.00	-5.20	Peak
2437.00	99.98	---	2.64	102.62	---	---	---	---	Fundamental
3195.00	42.92	---	4.95	47.86	---	74.00	54.00	-6.14	Peak
4110.00	41.65	---	6.34	47.99	---	74.00	54.00	-6.01	Peak
4875.00	44.29	---	8.12	52.41	---	74.00	54.00	-1.59	Peak

966 Chamber_B at 3Meter / Vertical									
Frequency (MHz)	Reading-PK (dBuV)	Reading-AV (dBuV)	Correction Factor (dB/m)	Result-PK (dBuV/m)	Result-AV (dBuV/m)	Limit-PK (dBuV/m)	Limit-AV (dBuV/m)	Margin (dB)	Remark
1126.00	49.34	---	-4.61	44.72	---	74.00	54.00	-9.28	Peak
1414.00	46.54	---	-3.62	42.92	---	74.00	54.00	-11.08	Peak
1800.00	49.05	---	-0.41	48.64	---	74.00	54.00	-5.36	Peak
2437.00	97.02	---	2.64	99.66	---	---	---	---	Fundamental
3255.00	49.81	47.33	4.90	54.71	52.23	74.00	54.00	-1.77	AVG
4410.00	41.59	---	7.52	49.12	---	74.00	54.00	-4.88	Peak
4875.00	58.41	44.55	8.12	66.53	52.67	74.00	54.00	-1.33	AVG

Remark:

1. Measuring frequencies from 1 GHz to the 10th harmonic of highest fundamental frequency.
2. Average test would be performed if the peak result were greater than the average limit.
3. Data of measurement within this frequency range shown " --- " in the table above means the reading of emissions are attenuated more than 20dB below the permissible limits or the field strength is too small to be measured.
4. Measurements above show only up to 6 maximum emissions noted, or would be lesser, with " N/A " remark, if no specific emissions from the EUT are recorded (ie: margin>20dB from the applicable limit) and considered that's already beyond the background noise floor.
5. In any 100 kHz bandwidth outside the frequency band in which the spread spectrum or digitally modulated intentional radiator is operating, the radio frequency power that is produced by the intentional radiator shall be at least 20 dB below that in the 100 kHz bandwidth within the band that contains the highest level of the desired power, based on either an RF conducted or a radiated measurement, provided the transmitter demonstrates compliance with the peak conducted power limits. If the transmitter complies with the conducted power limits based on the use of RMS averaging over a time interval, as permitted under paragraph (b)(3) of this section, the attenuation required under this paragraph shall be 30 dB instead of 20 dB.
6. Result = Reading + Correction Factor
Margin = Result - Limit
Remark Peak = Result(PK) - Limit(AV)
Remark AVG = Result(AV) - Limit(AV)



Product Name	8x4 D3 Wireless Router	Test By	Waternil Guan
Test Model	CGN2-ROG01129	Test Date	2011/09/08
Test Mode	IEEE 802.11n HT20 TX / CH High	TEMP & Humidity	24°C, 57%

966 Chamber_B at 3Meter / Horizontal									
Frequency (MHz)	Reading-PK (dBuV)	Reading-AV (dBuV)	Correction Factor (dB/m)	Result-PK (dBuV/m)	Result-AV (dBuV/m)	Limit-PK (dBuV/m)	Limit-AV (dBuV/m)	Margin (dB)	Remark
1126.00	51.32	---	-4.61	46.71	---	74.00	54.00	-7.29	Peak
1270.00	46.41	---	-4.12	42.29	---	74.00	54.00	-11.71	Peak
1800.00	48.10	---	-0.41	47.69	---	74.00	54.00	-6.31	Peak
2462.00	98.27	---	2.71	100.98	---	---	---	---	Fundamental
3120.00	44.00	---	5.01	49.01	---	74.00	54.00	-4.99	Peak
4605.00	41.77	---	7.95	49.72	---	74.00	54.00	-4.28	Peak
4920.00	50.43	37.00	8.15	58.58	45.15	74.00	54.00	-8.85	Peak

966 Chamber_B at 3Meter / Vertical									
Frequency (MHz)	Reading-PK (dBuV)	Reading-AV (dBuV)	Correction Factor (dB/m)	Result-PK (dBuV/m)	Result-AV (dBuV/m)	Limit-PK (dBuV/m)	Limit-AV (dBuV/m)	Margin (dB)	Remark
1124.00	49.29	---	-4.62	44.67	---	74.00	54.00	-9.33	Peak
1400.00	47.13	---	-3.67	43.47	---	74.00	54.00	-10.53	Peak
1844.00	45.35	---	0.02	45.36	---	74.00	54.00	-8.64	Peak
2462.00	96.56	---	2.70	99.25	---	---	---	---	Fundamental
3285.00	50.10	47.86	4.87	54.97	52.73	74.00	54.00	-1.27	AVG
4350.00	41.94	---	7.29	49.23	---	74.00	54.00	-4.77	Peak
4935.00	58.43	44.80	8.16	66.59	52.96	74.00	54.00	-1.04	AVG

Remark:

1. Measuring frequencies from 1 GHz to the 10th harmonic of highest fundamental frequency.
2. Average test would be performed if the peak result were greater than the average limit.
3. Data of measurement within this frequency range shown " --- " in the table above means the reading of emissions are attenuated more than 20dB below the permissible limits or the field strength is too small to be measured.
4. Measurements above show only up to 6 maximum emissions noted, or would be lesser, with " N/A " remark, if no specific emissions from the EUT are recorded (ie: margin>20dB from the applicable limit) and considered that's already beyond the background noise floor.
5. In any 100 kHz bandwidth outside the frequency band in which the spread spectrum or digitally modulated intentional radiator is operating, the radio frequency power that is produced by the intentional radiator shall be at least 20 dB below that in the 100 kHz bandwidth within the band that contains the highest level of the desired power, based on either an RF conducted or a radiated measurement, provided the transmitter demonstrates compliance with the peak conducted power limits. If the transmitter complies with the conducted power limits based on the use of RMS averaging over a time interval, as permitted under paragraph (b)(3) of this section, the attenuation required under this paragraph shall be 30 dB instead of 20 dB.
6. Result = Reading + Correction Factor
Margin = Result - Limit
Remark Peak = Result(PK) - Limit(AV)
Remark AVG = Result(AV) - Limit(AV)



Product Name	8x4 D3 Wireless Router	Test By	Waternil Guan
Test Model	CGN2-ROG01129	Test Date	2011/09/08
Test Mode	IEEE 802.11n HT40 TX / CH Low	TEMP & Humidity	24°C, 57%

966 Chamber_B at 3Meter / Horizontal									
Frequency (MHz)	Reading-PK (dBuV)	Reading-AV (dBuV)	Correction Factor (dB/m)	Result-PK (dBuV/m)	Result-AV (dBuV/m)	Limit-PK (dBuV/m)	Limit-AV (dBuV/m)	Margin (dB)	Remark
1126.00	51.51	---	-4.61	46.89	---	74.00	54.00	-7.11	Peak
1500.00	45.95	---	-3.32	42.63	---	74.00	54.00	-11.37	Peak
1800.00	49.53	---	-0.41	49.12	---	74.00	54.00	-4.88	Peak
2422.00	98.50	---	2.59	101.09	---	---	---	---	Fundamental
3090.00	43.42	---	5.03	48.46	---	74.00	54.00	-5.54	Peak
4470.00	41.52	---	7.76	49.28	---	74.00	54.00	-4.72	Peak
4845.00	43.35	---	8.10	51.45	---	74.00	54.00	-2.55	Peak

966 Chamber_B at 3Meter / Vertical									
Frequency (MHz)	Reading-PK (dBuV)	Reading-AV (dBuV)	Correction Factor (dB/m)	Result-PK (dBuV/m)	Result-AV (dBuV/m)	Limit-PK (dBuV/m)	Limit-AV (dBuV/m)	Margin (dB)	Remark
1124.00	49.18	---	-4.62	44.56	---	74.00	54.00	-9.44	Peak
1374.00	46.77	---	-3.76	43.02	---	74.00	54.00	-10.98	Peak
1800.00	48.54	---	-0.41	48.13	---	74.00	54.00	-5.87	Peak
2422.00	93.55	---	2.61	96.15	---	---	---	---	Fundamental
3225.00	50.10	47.00	4.92	55.02	51.92	74.00	54.00	-2.08	AVG
4530.00	41.60	---	7.90	49.50	---	74.00	54.00	-4.50	Peak
4860.00	56.44	44.11	8.11	64.55	52.22	74.00	54.00	-1.78	AVG

Remark:

1. Measuring frequencies from 1 GHz to the 10th harmonic of highest fundamental frequency.
2. Average test would be performed if the peak result were greater than the average limit.
3. Data of measurement within this frequency range shown " --- " in the table above means the reading of emissions are attenuated more than 20dB below the permissible limits or the field strength is too small to be measured.
4. Measurements above show only up to 6 maximum emissions noted, or would be lesser, with " N/A " remark, if no specific emissions from the EUT are recorded (ie: margin>20dB from the applicable limit) and considered that's already beyond the background noise floor.
5. In any 100 kHz bandwidth outside the frequency band in which the spread spectrum or digitally modulated intentional radiator is operating, the radio frequency power that is produced by the intentional radiator shall be at least 20 dB below that in the 100 kHz bandwidth within the band that contains the highest level of the desired power, based on either an RF conducted or a radiated measurement, provided the transmitter demonstrates compliance with the peak conducted power limits. If the transmitter complies with the conducted power limits based on the use of RMS averaging over a time interval, as permitted under paragraph (b)(3) of this section, the attenuation required under this paragraph shall be 30 dB instead of 20 dB.
6. Result = Reading + Correction Factor
Margin = Result - Limit
Remark Peak = Result(PK) - Limit(AV)
Remark AVG = Result(AV) - Limit(AV)



Product Name	8x4 D3 Wireless Router	Test By	Waternil Guan
Test Model	CGN2-ROG01129	Test Date	2011/09/08
Test Mode	IEEE 802.11n HT40 TX / CH Middle	TEMP & Humidity	24°C, 57%

966 Chamber_B at 3Meter / Horizontal									
Frequency (MHz)	Reading-PK (dBuV)	Reading-AV (dBuV)	Correction Factor (dB/m)	Result-PK (dBuV/m)	Result-AV (dBuV/m)	Limit-PK (dBuV/m)	Limit-AV (dBuV/m)	Margin (dB)	Remark
1080.00	48.94	---	-4.77	44.16	---	74.00	54.00	-9.84	Peak
1126.00	50.72	---	-4.61	46.10	---	74.00	54.00	-7.90	Peak
1800.00	48.14	---	-0.41	47.73	---	74.00	54.00	-6.27	Peak
2437.00	97.84	---	2.63	100.48	---	---	---	---	Fundamental
3060.00	43.79	---	5.06	48.85	---	74.00	54.00	-5.15	Peak
4305.00	41.32	---	7.11	48.43	---	74.00	54.00	-5.57	Peak
4875.00	46.00	35.76	8.12	54.12	43.88	74.00	54.00	-10.12	AVG

966 Chamber_B at 3Meter / Vertical									
Frequency (MHz)	Reading-PK (dBuV)	Reading-AV (dBuV)	Correction Factor (dB/m)	Result-PK (dBuV/m)	Result-AV (dBuV/m)	Limit-PK (dBuV/m)	Limit-AV (dBuV/m)	Margin (dB)	Remark
1124.00	49.30	---	-4.62	44.68	---	74.00	54.00	-9.32	Peak
1400.00	48.09	---	-3.67	44.42	---	74.00	54.00	-9.58	Peak
1800.00	48.37	---	-0.41	47.96	---	74.00	54.00	-6.04	Peak
2437.00	94.46	---	2.65	97.11	---	---	---	---	Fundamental
3255.00	50.60	47.40	4.90	55.50	52.30	74.00	54.00	-1.70	AVG
4575.00	40.98	---	7.93	48.91	---	74.00	54.00	-5.09	Peak
4875.00	55.97	44.57	8.12	64.09	52.69	74.00	54.00	-1.31	AVG

Remark:

1. Measuring frequencies from 1 GHz to the 10th harmonic of highest fundamental frequency.
2. Average test would be performed if the peak result were greater than the average limit.
3. Data of measurement within this frequency range shown " --- " in the table above means the reading of emissions are attenuated more than 20dB below the permissible limits or the field strength is too small to be measured.
4. Measurements above show only up to 6 maximum emissions noted, or would be lesser, with " N/A " remark, if no specific emissions from the EUT are recorded (ie: margin>20dB from the applicable limit) and considered that's already beyond the background noise floor.
5. In any 100 kHz bandwidth outside the frequency band in which the spread spectrum or digitally modulated intentional radiator is operating, the radio frequency power that is produced by the intentional radiator shall be at least 20 dB below that in the 100 kHz bandwidth within the band that contains the highest level of the desired power, based on either an RF conducted or a radiated measurement, provided the transmitter demonstrates compliance with the peak conducted power limits. If the transmitter complies with the conducted power limits based on the use of RMS averaging over a time interval, as permitted under paragraph (b)(3) of this section, the attenuation required under this paragraph shall be 30 dB instead of 20 dB.
6. Result = Reading + Correction Factor
Margin = Result - Limit
Remark Peak = Result(PK) - Limit(AV)
Remark AVG = Result(AV) - Limit(AV)



Product Name	8x4 D3 Wireless Router	Test By	Waternil Guan
Test Model	CGN2-ROG01129	Test Date	2011/09/08
Test Mode	IEEE 802.11n HT40 TX / CH High	TEMP & Humidity	24°C, 57%

966 Chamber_B at 3Meter / Horizontal									
Frequency (MHz)	Reading-PK (dBuV)	Reading-AV (dBuV)	Correction Factor (dB/m)	Result-PK (dBuV/m)	Result-AV (dBuV/m)	Limit-PK (dBuV/m)	Limit-AV (dBuV/m)	Margin (dB)	Remark
1124.00	50.79	---	-4.62	46.17	---	74.00	54.00	-7.83	Peak
1250.00	47.07	---	-4.18	42.89	---	74.00	54.00	-11.11	Peak
1800.00	49.05	---	-0.41	48.64	---	74.00	54.00	-5.36	Peak
2452.00	96.91	---	2.67	99.57	---	---	---	---	Fundamental
3270.00	44.01	---	4.88	48.90	---	74.00	54.00	-5.10	Peak
4320.00	41.77	---	7.17	48.94	---	74.00	54.00	-5.06	Peak
4905.00	46.46	35.09	8.14	54.60	43.23	74.00	54.00	-10.77	AVG

966 Chamber_B at 3Meter / Vertical									
Frequency (MHz)	Reading-PK (dBuV)	Reading-AV (dBuV)	Correction Factor (dB/m)	Result-PK (dBuV/m)	Result-AV (dBuV/m)	Limit-PK (dBuV/m)	Limit-AV (dBuV/m)	Margin (dB)	Remark
1126.00	49.16	---	-4.61	44.55	---	74.00	54.00	-9.45	Peak
1440.00	46.27	---	-3.53	42.74	---	74.00	54.00	-11.26	Peak
2304.00	48.24	---	2.30	50.54	---	74.00	54.00	-3.46	Peak
2452.00	93.84	---	2.65	96.49	---	---	---	---	Fundamental
3270.00	50.50	47.81	4.88	55.38	52.69	74.00	54.00	-1.31	AVG
4440.00	41.41	---	7.64	49.05	---	74.00	54.00	-4.95	Peak
4905.00	55.26	44.69	8.14	63.40	52.83	74.00	54.00	-1.17	AVG

Remark:

1. Measuring frequencies from 1 GHz to the 10th harmonic of highest fundamental frequency.
2. Average test would be performed if the peak result were greater than the average limit.
3. Data of measurement within this frequency range shown " --- " in the table above means the reading of emissions are attenuated more than 20dB below the permissible limits or the field strength is too small to be measured.
4. Measurements above show only up to 6 maximum emissions noted, or would be lesser, with " N/A " remark, if no specific emissions from the EUT are recorded (ie: margin>20dB from the applicable limit) and considered that's already beyond the background noise floor.
5. In any 100 kHz bandwidth outside the frequency band in which the spread spectrum or digitally modulated intentional radiator is operating, the radio frequency power that is produced by the intentional radiator shall be at least 20 dB below that in the 100 kHz bandwidth within the band that contains the highest level of the desired power, based on either an RF conducted or a radiated measurement, provided the transmitter demonstrates compliance with the peak conducted power limits. If the transmitter complies with the conducted power limits based on the use of RMS averaging over a time interval, as permitted under paragraph (b)(3) of this section, the attenuation required under this paragraph shall be 30 dB instead of 20 dB.
6. Result = Reading + Correction Factor
Margin = Result - Limit
Remark Peak = Result(PK) - Limit(AV)
Remark AVG = Result(AV) - Limit(AV)



Restricted Band Edges

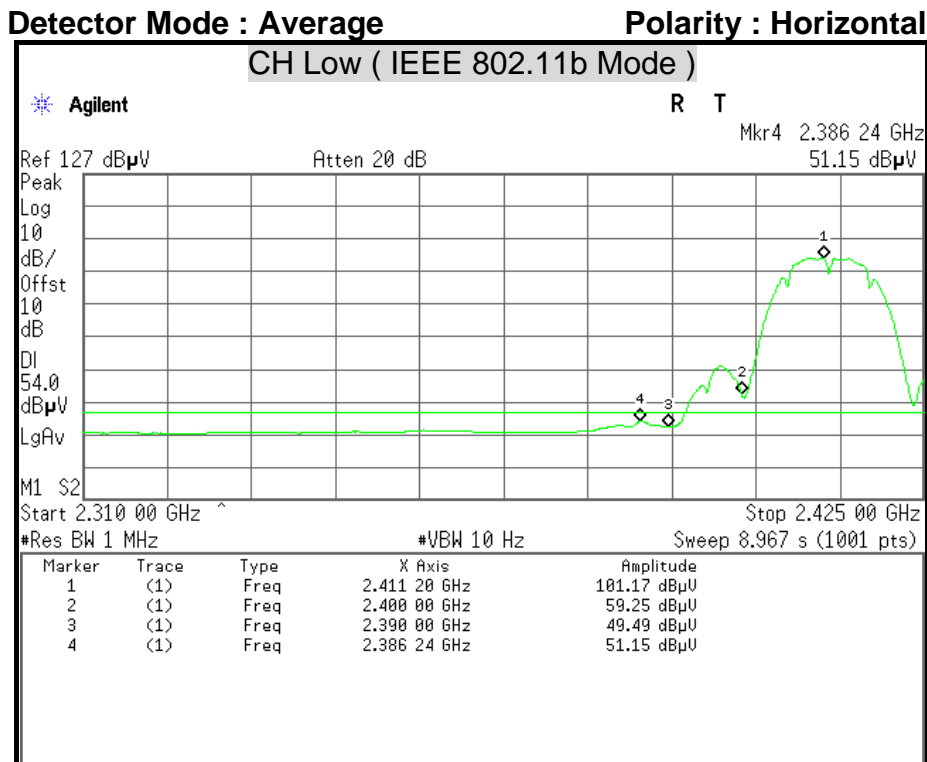
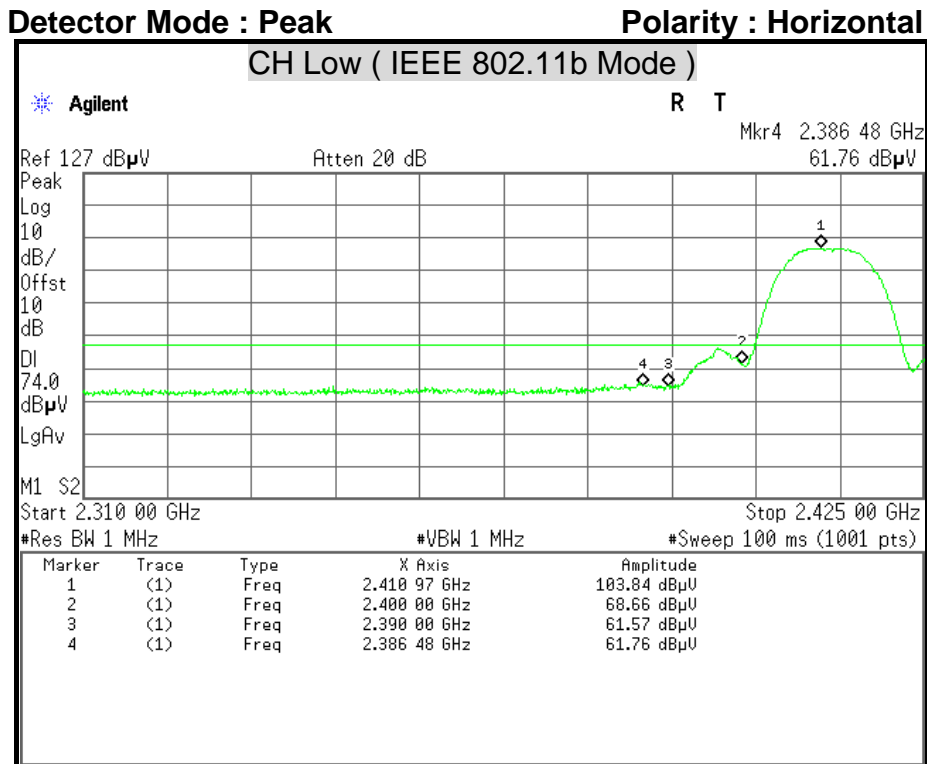



Detector Mode : Peak

Polarity : Vertical

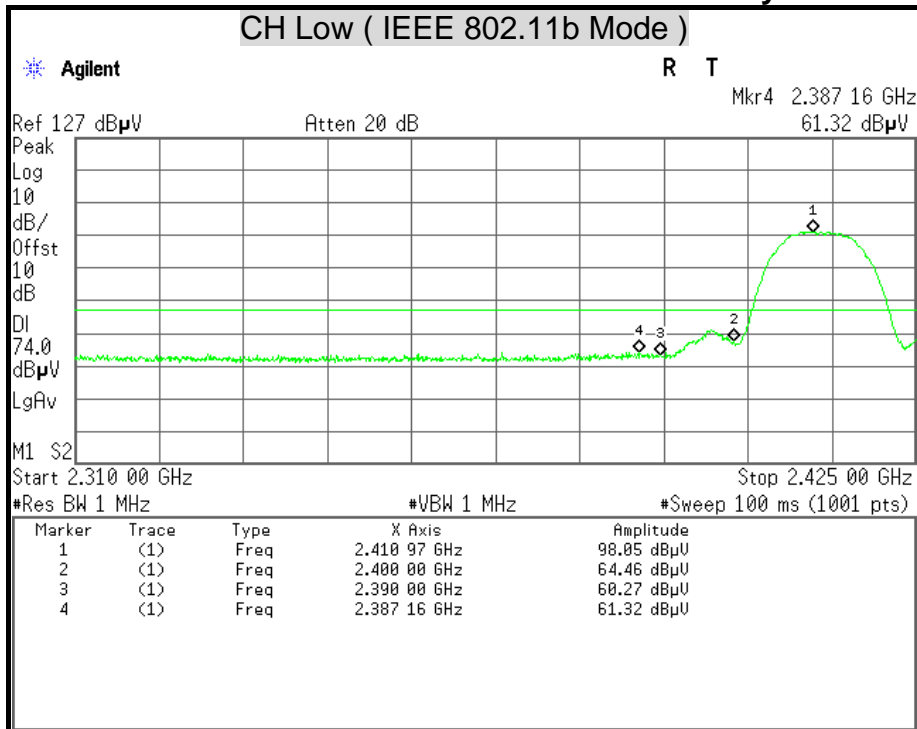

Detector Mode : Average

Polarity : Vertical

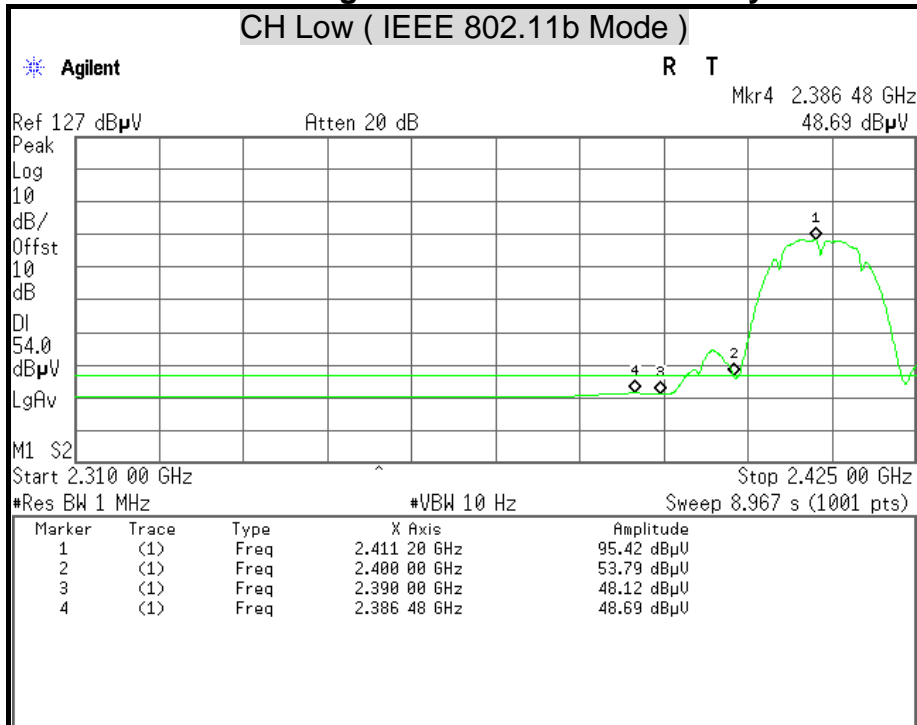



Detector Mode : Peak

Polarity : Horizontal

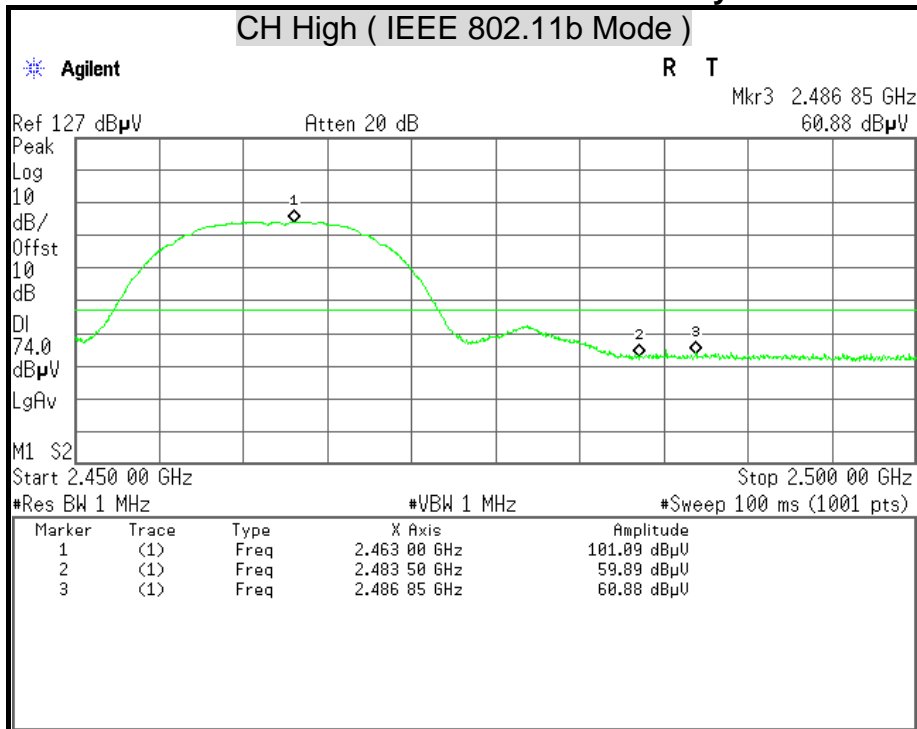

Detector Mode : Average

Polarity : Horizontal

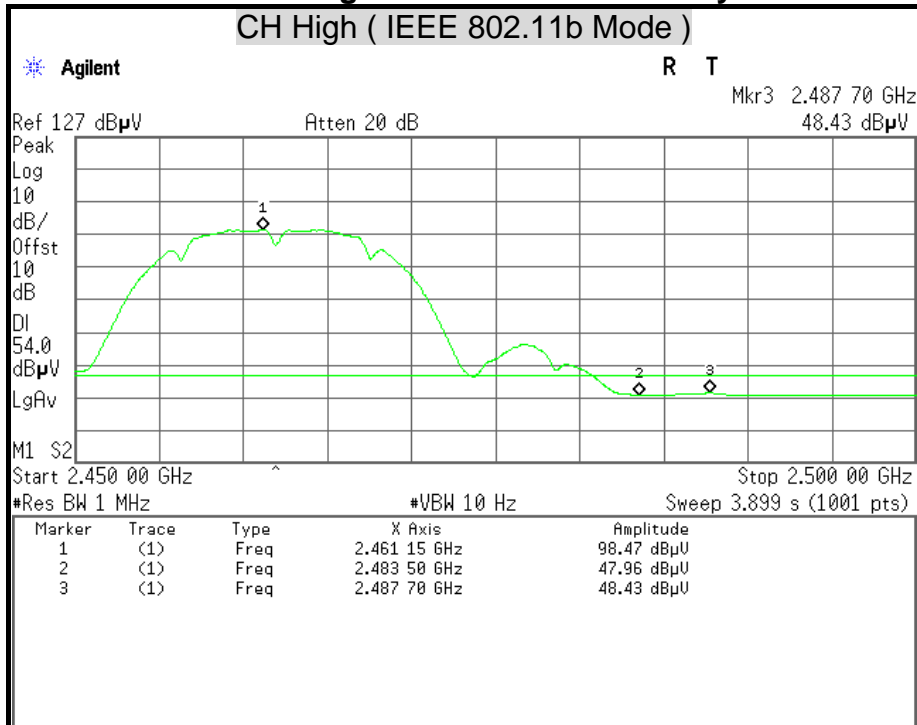



Detector Mode : Peak

Polarity : Vertical

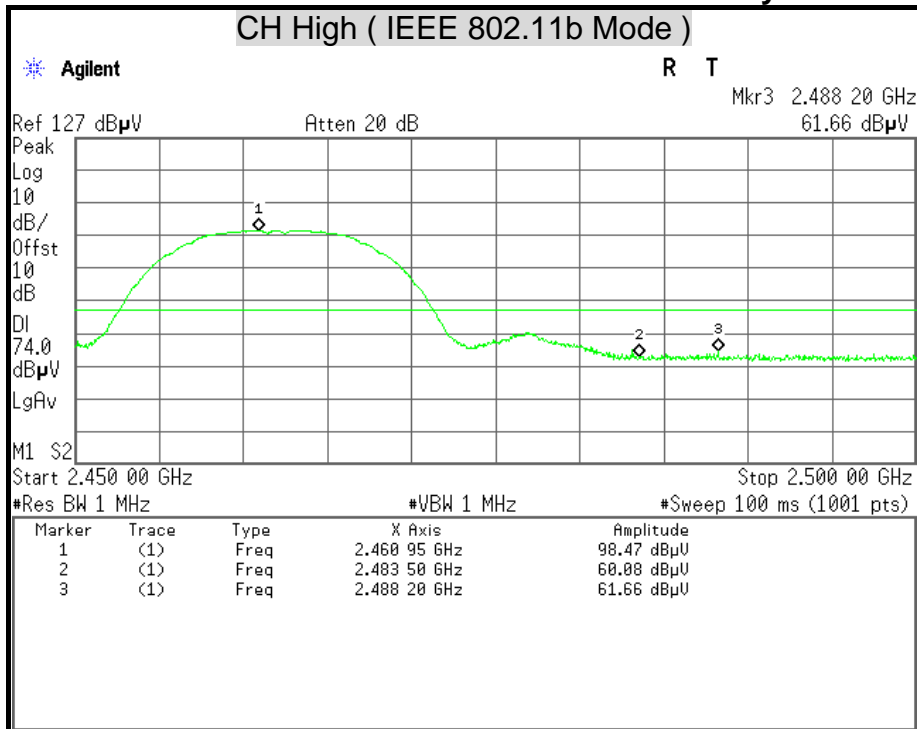

Detector Mode : Average

Polarity : Vertical

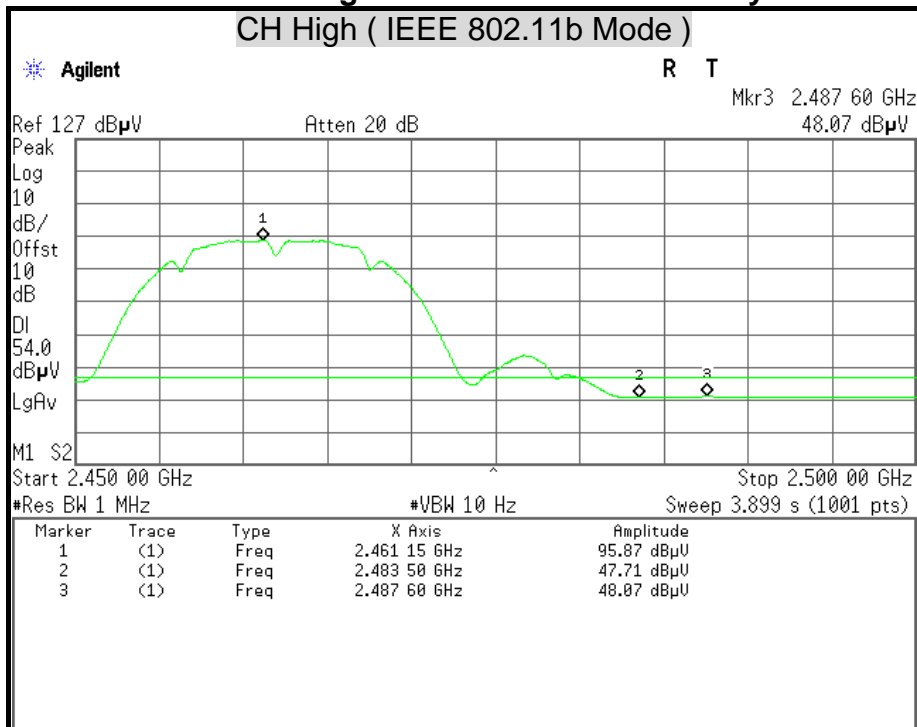



Detector Mode : Peak

Polarity : Horizontal

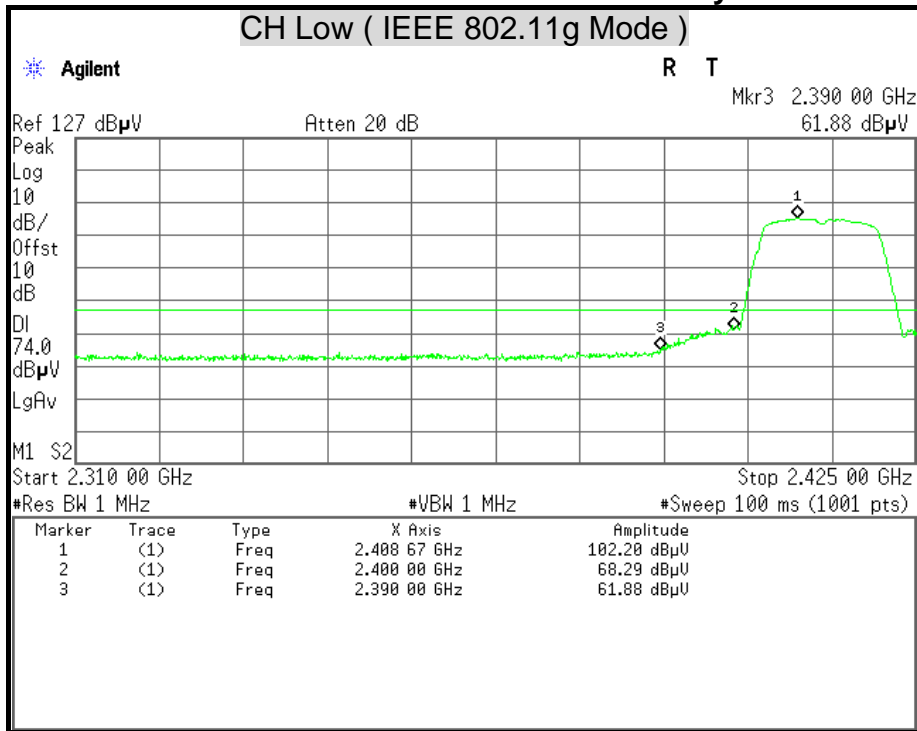

Detector Mode : Average

Polarity : Horizontal

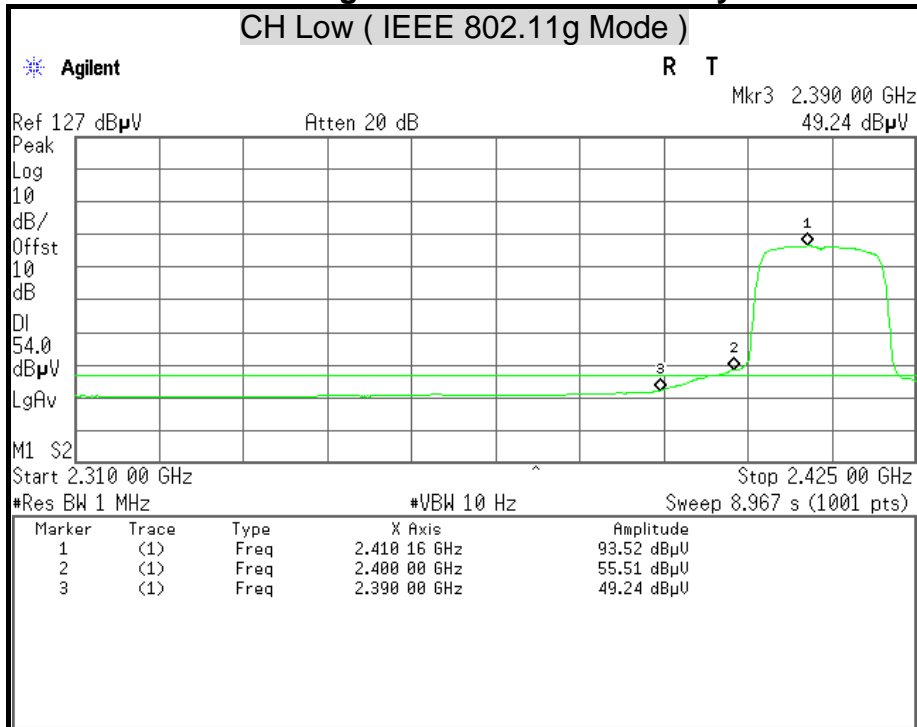



Detector Mode : Peak

Polarity : Vertical

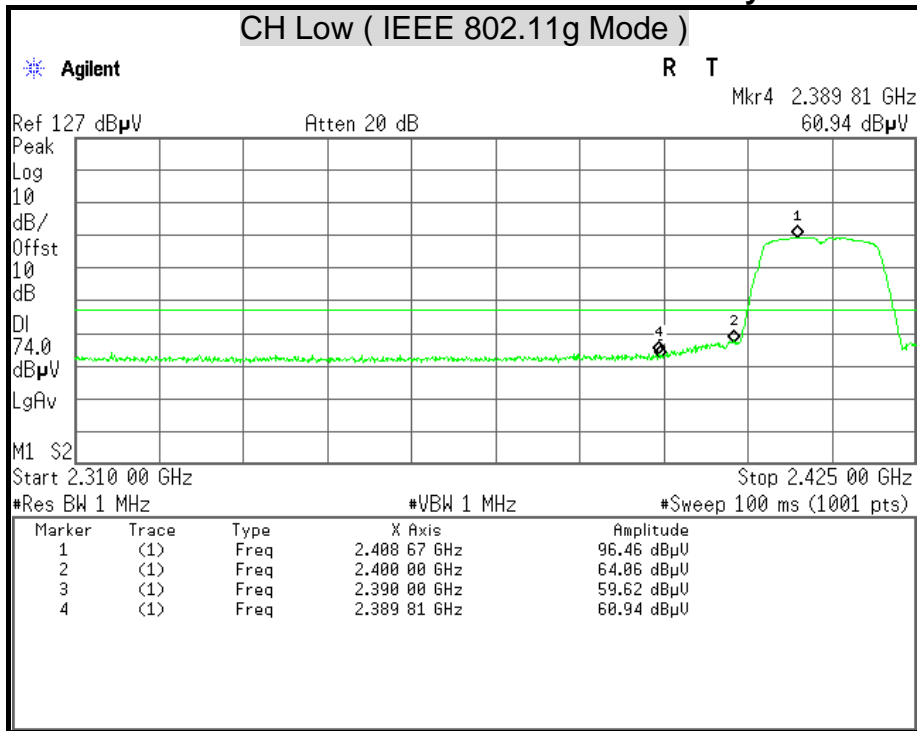

Detector Mode : Average

Polarity : Vertical

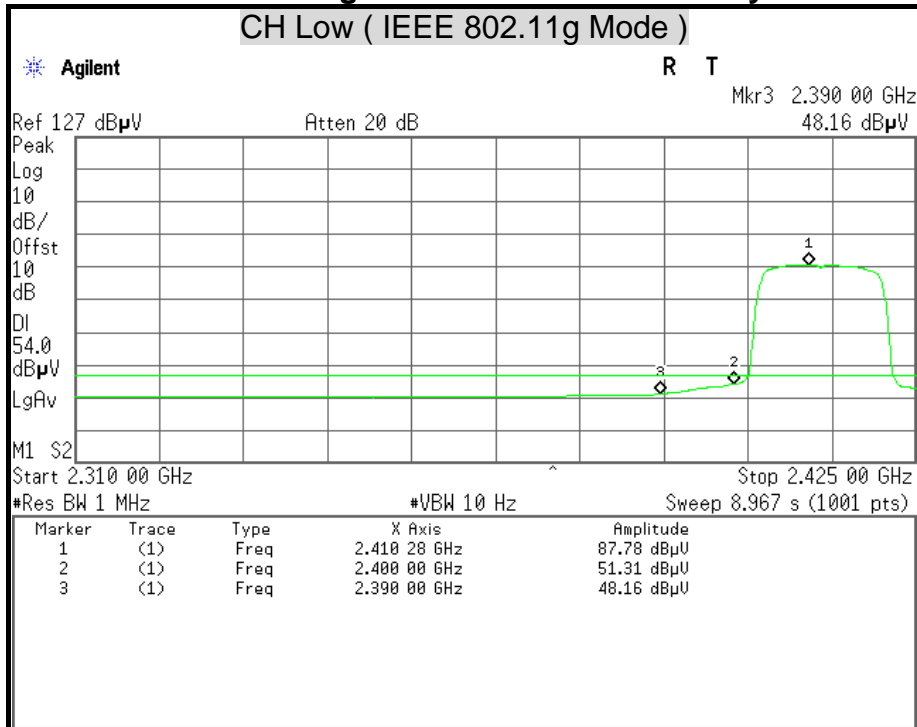



Detector Mode : Peak

Polarity : Horizontal

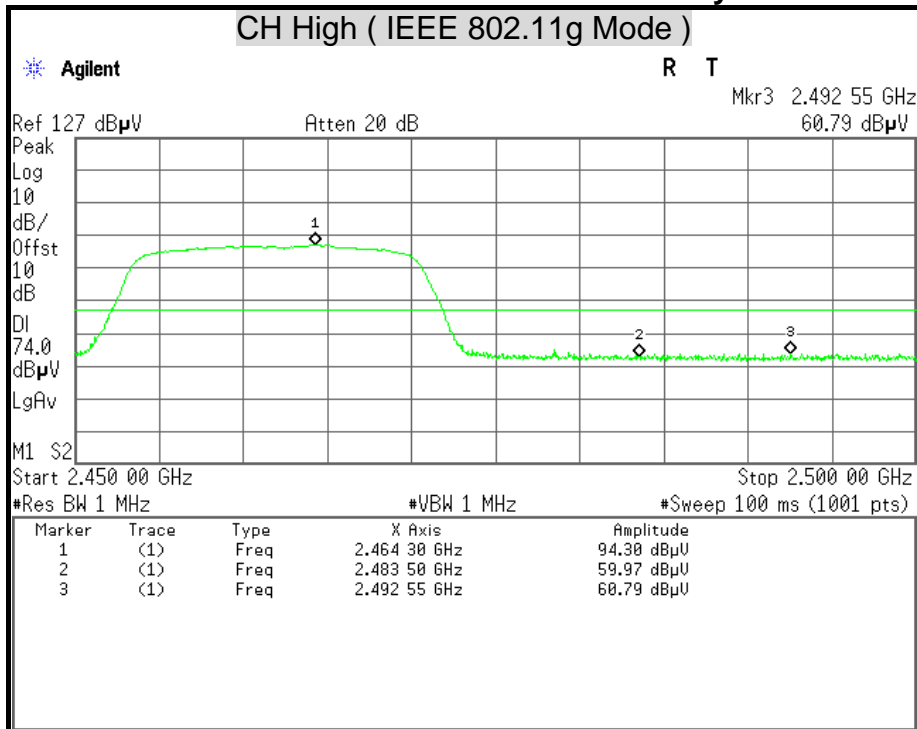

Detector Mode : Average

Polarity : Horizontal

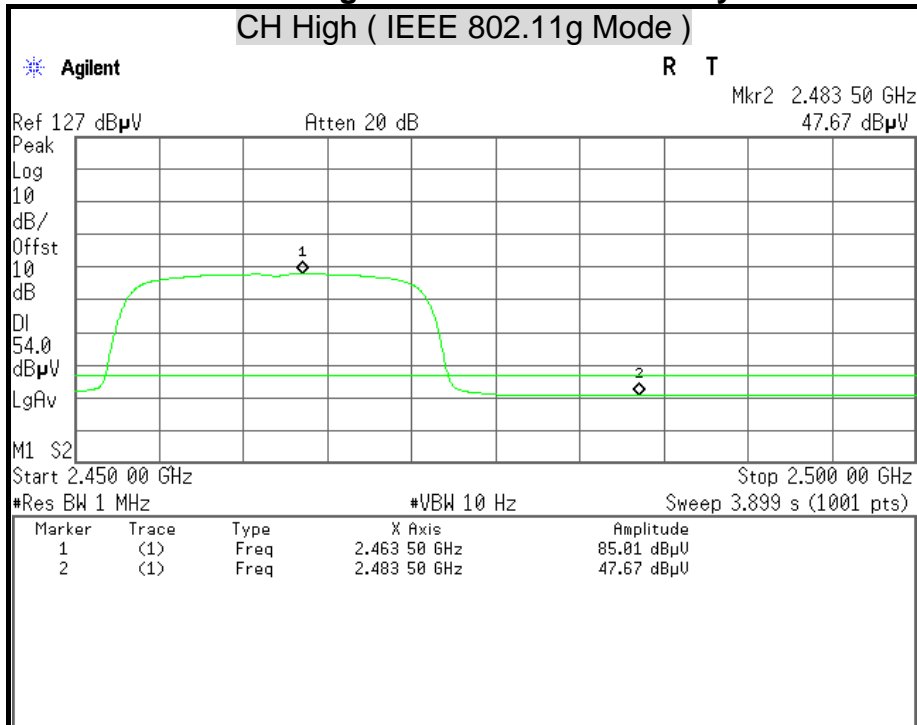



Detector Mode : Peak

Polarity : Vertical

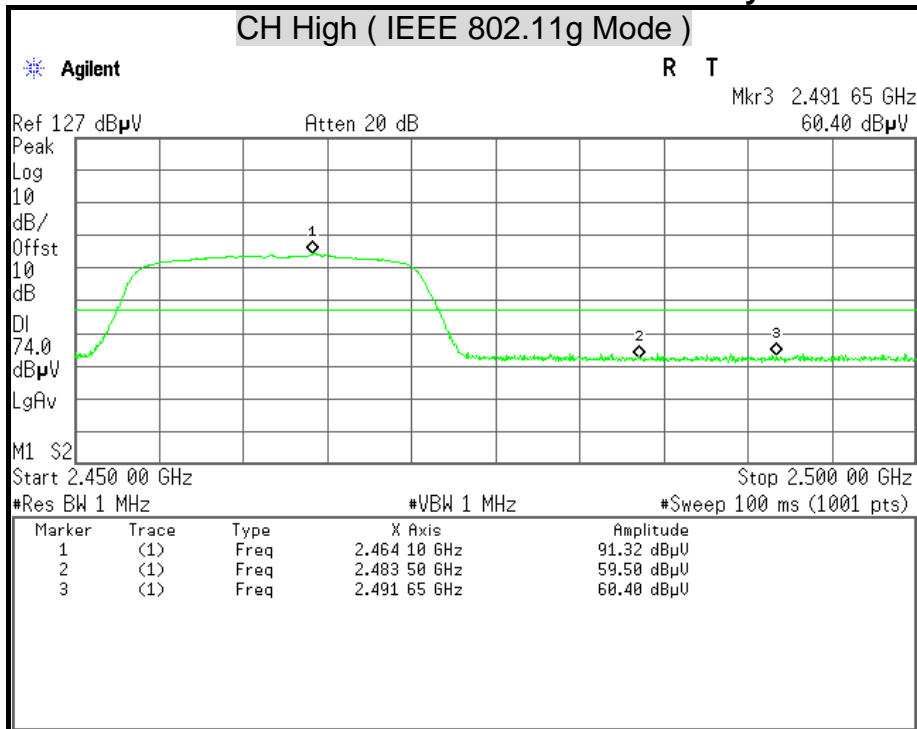

Detector Mode : Average

Polarity : Vertical

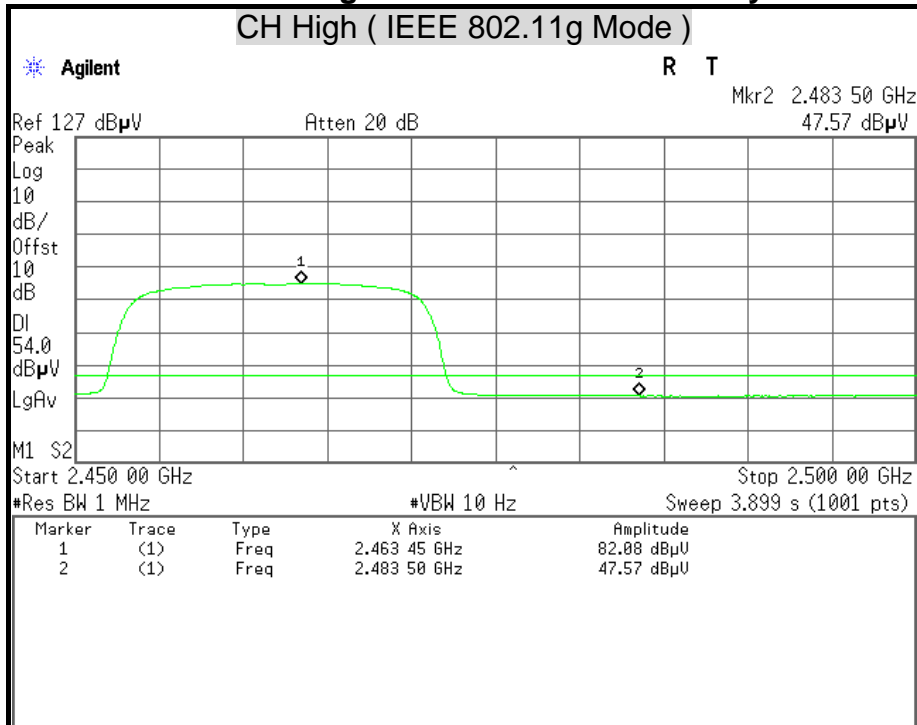



Detector Mode : Peak

Polarity : Horizontal

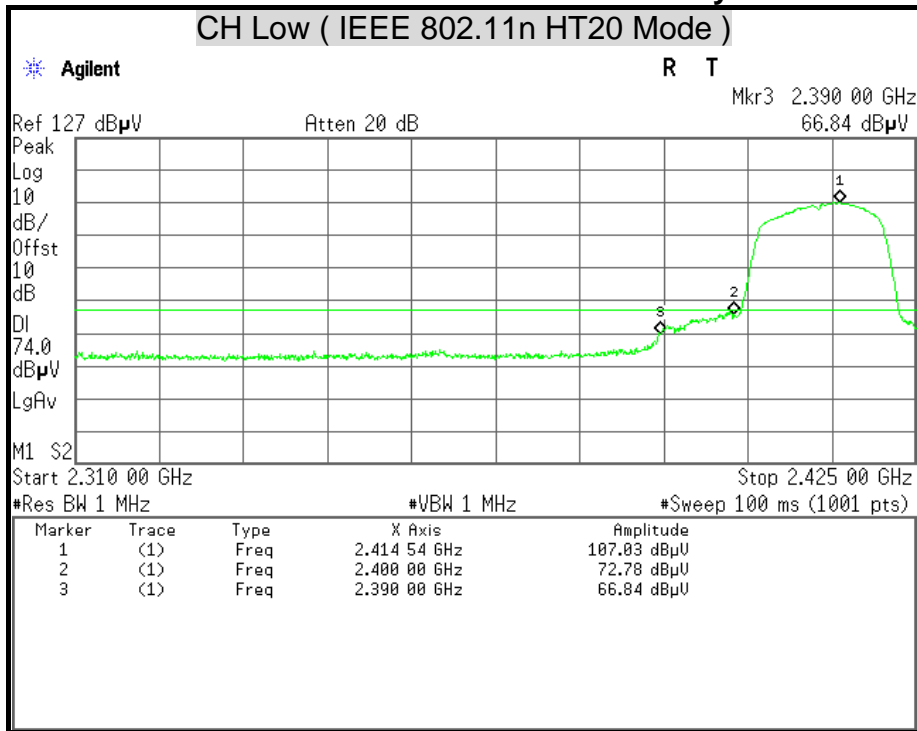

Detector Mode : Average

Polarity : Horizontal

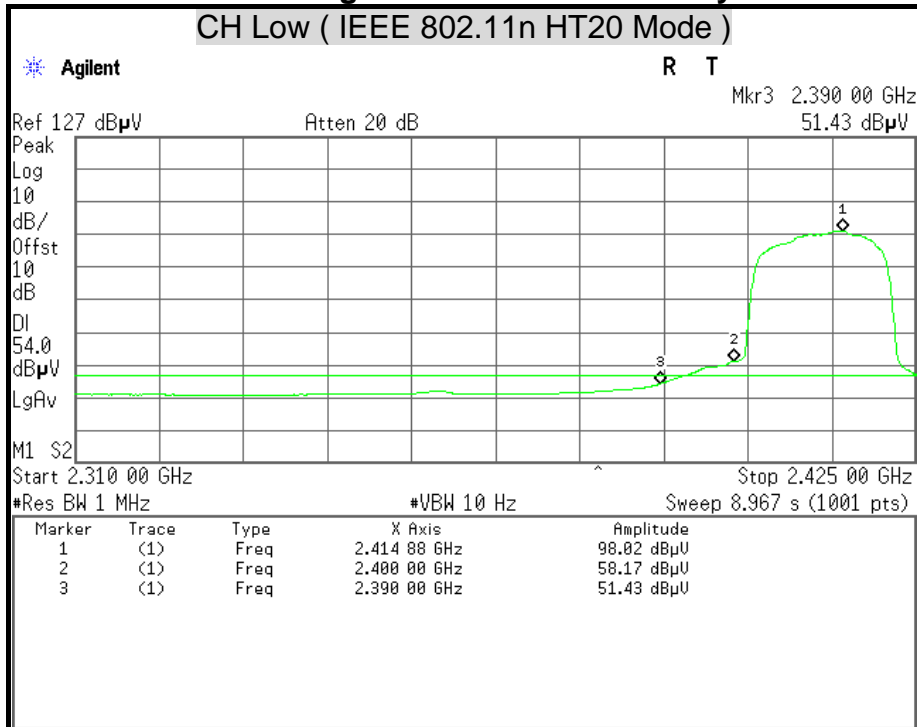



Detector Mode : Peak

Polarity : Vertical

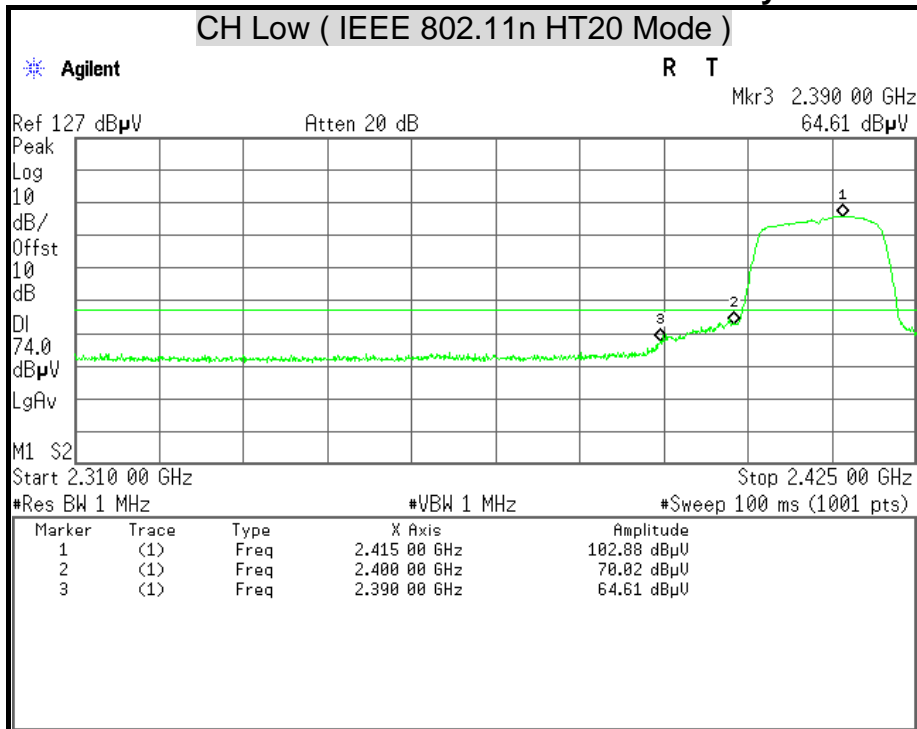

Detector Mode : Average

Polarity : Vertical

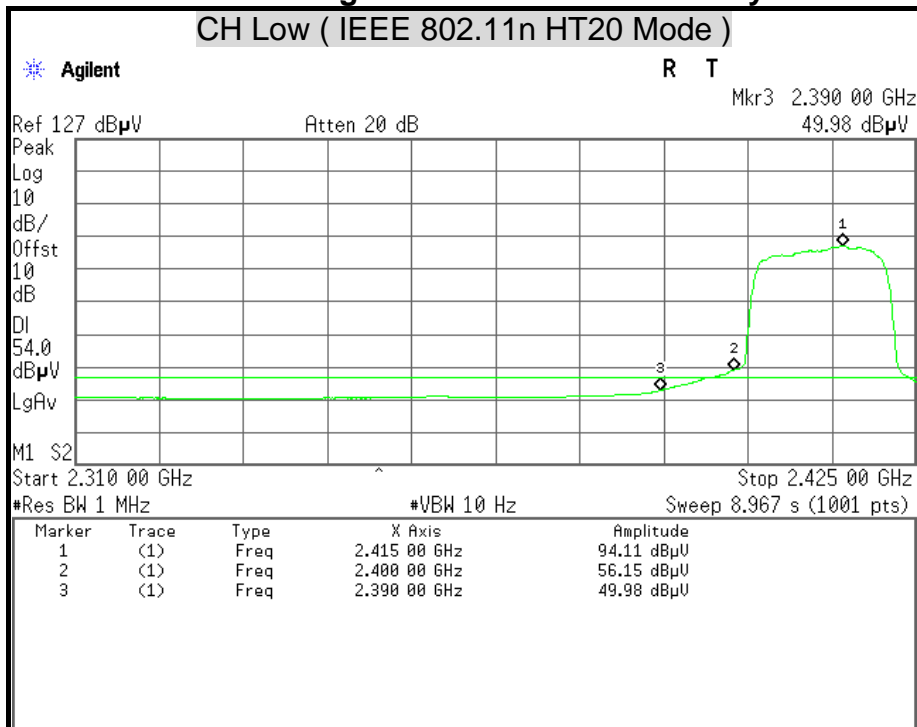



Detector Mode : Peak

Polarity : Horizontal

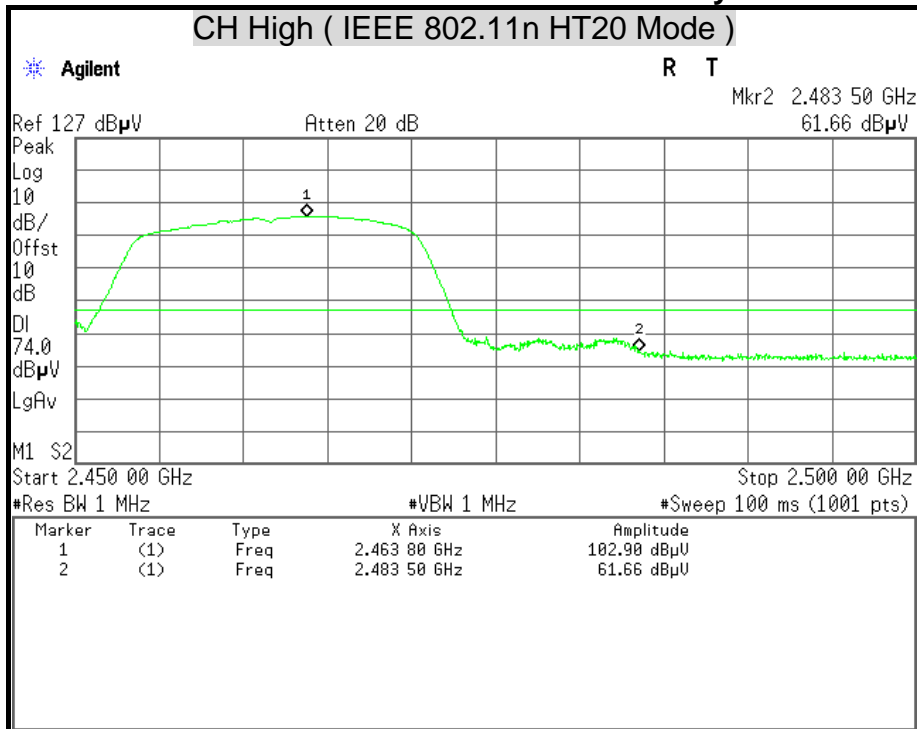

Detector Mode : Average

Polarity : Horizontal

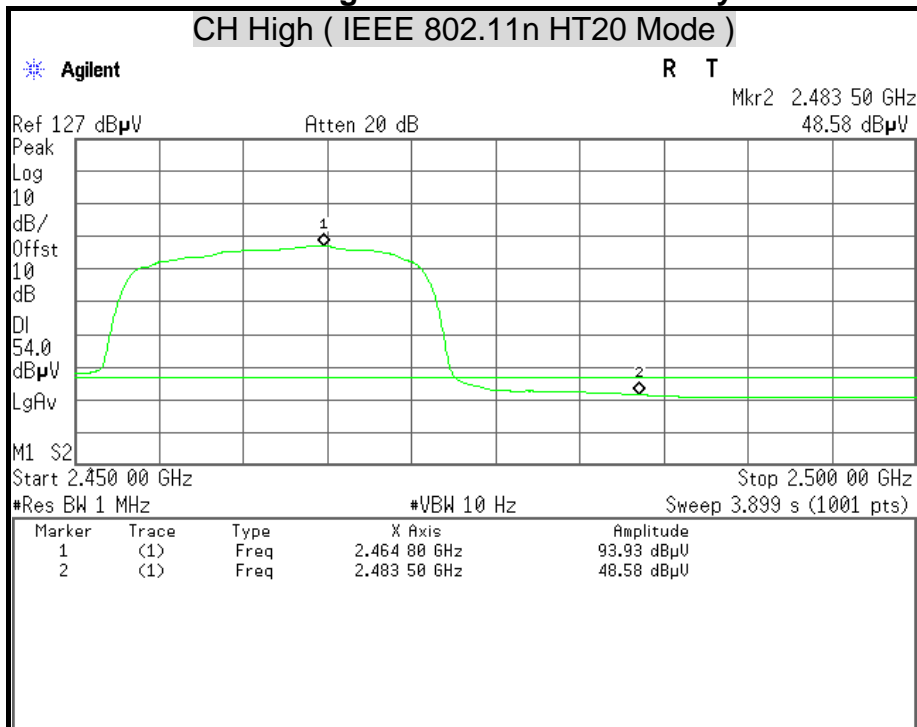



Detector Mode : Peak

Polarity : Vertical

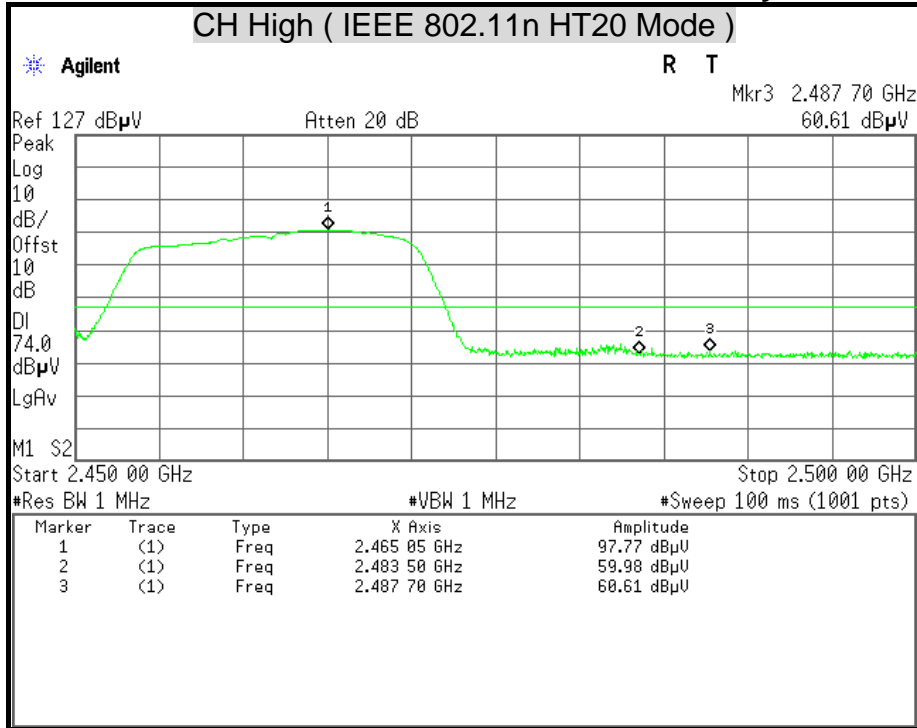

Detector Mode : Average

Polarity : Vertical

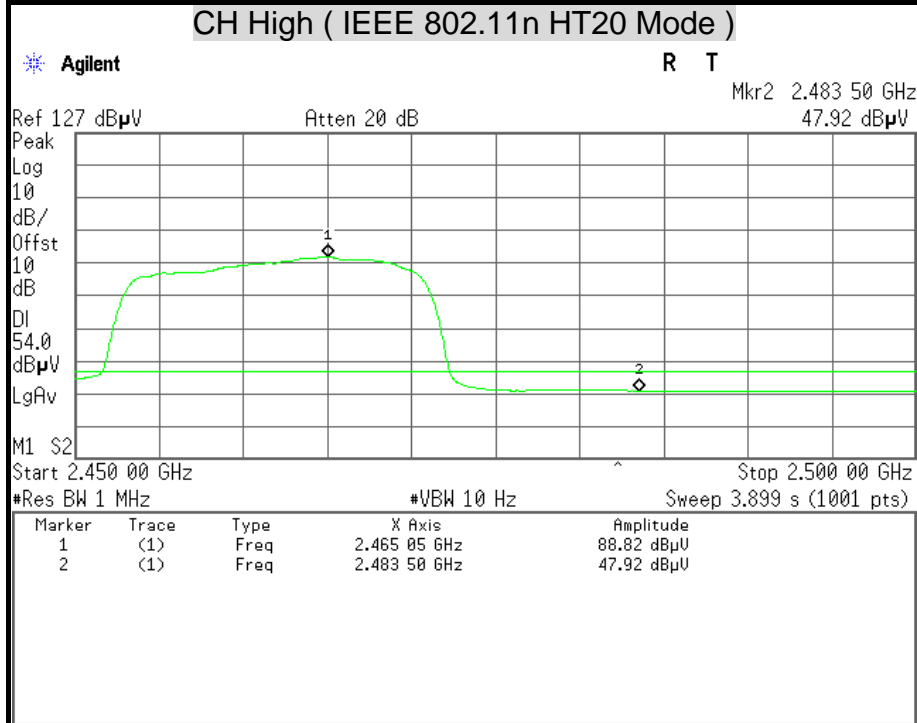



Detector Mode : Peak

Polarity : Horizontal

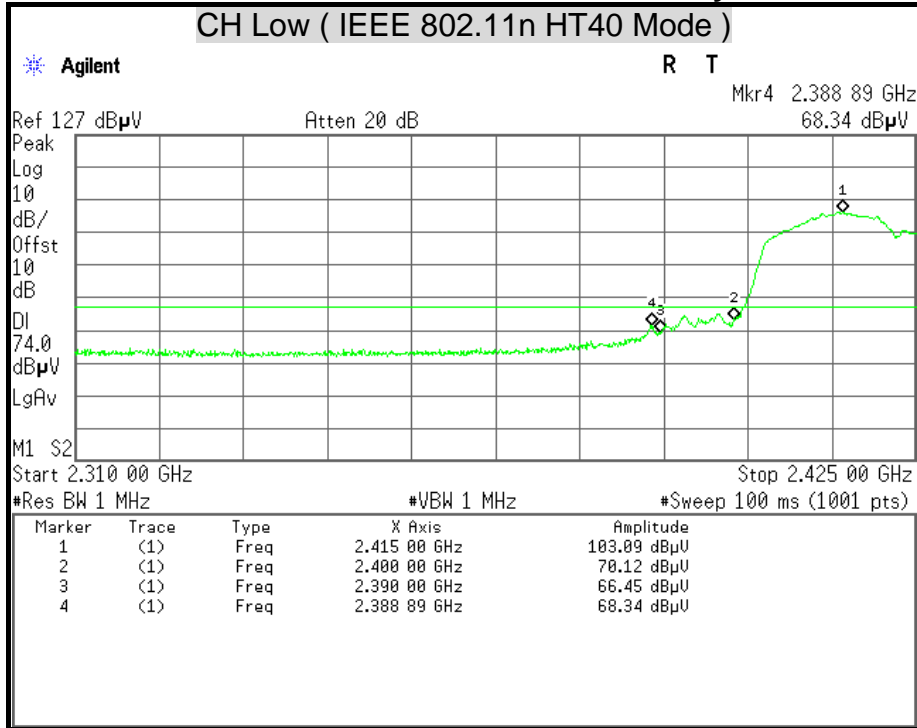

Detector Mode : Average

Polarity : Horizontal

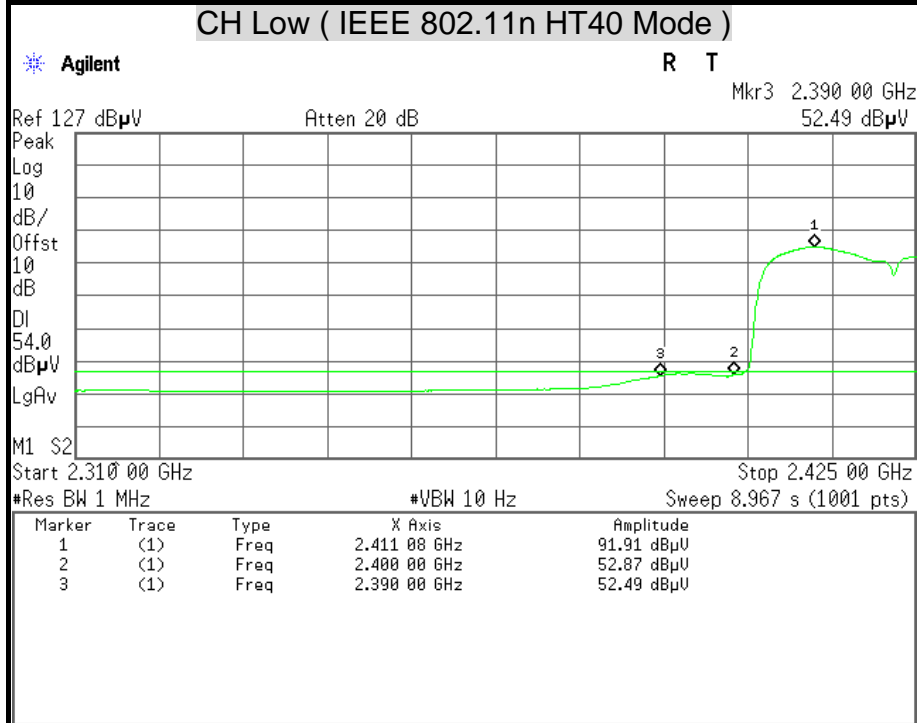



Detector Mode : Peak

Polarity : Vertical

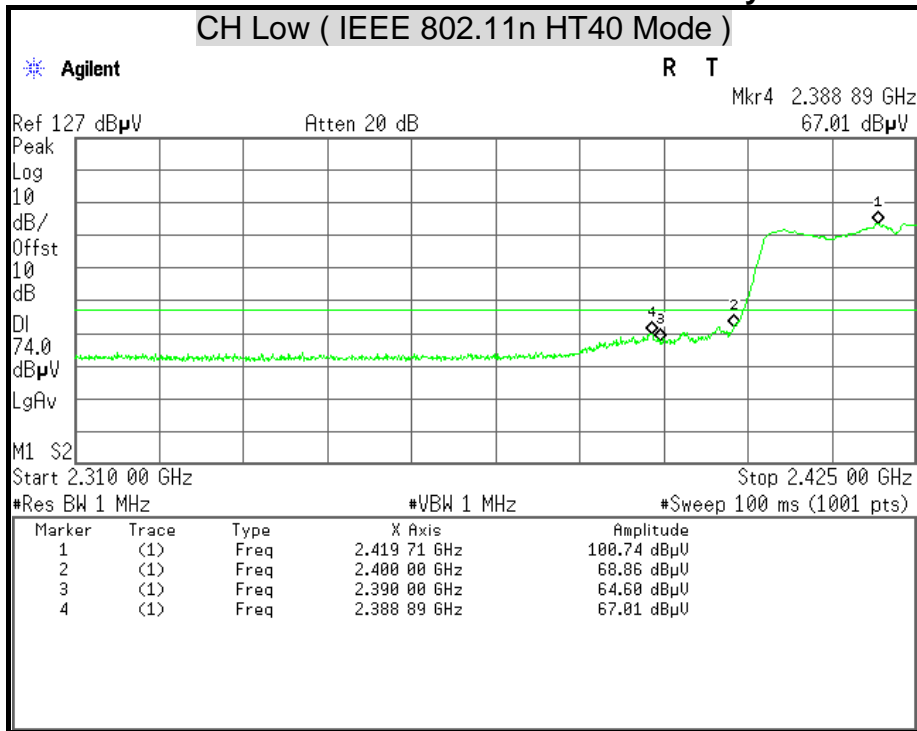

Detector Mode : Average

Polarity : Vertical

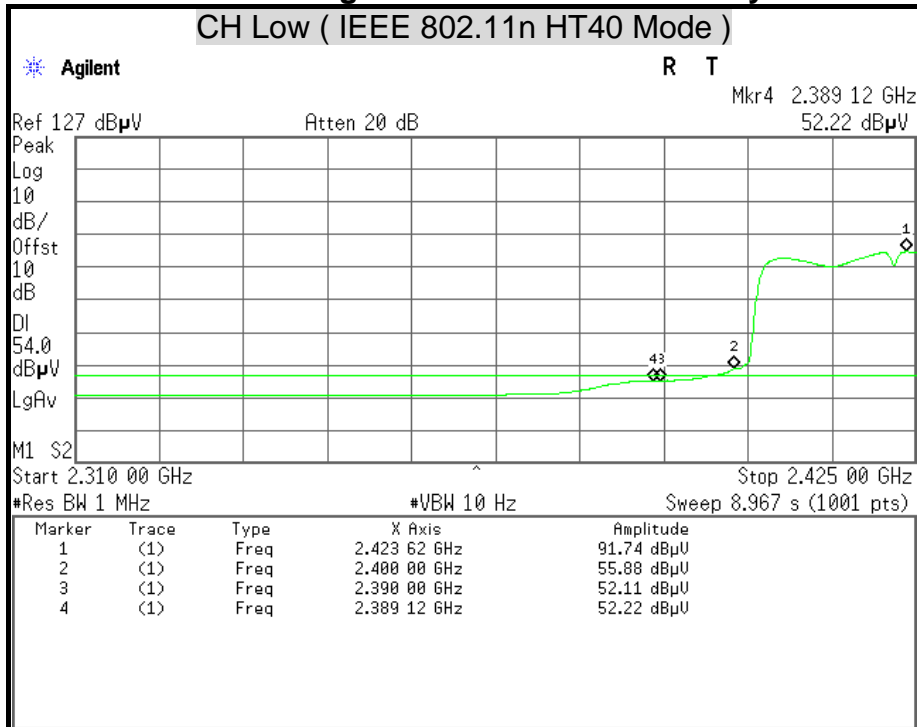



Detector Mode : Peak

Polarity : Horizontal

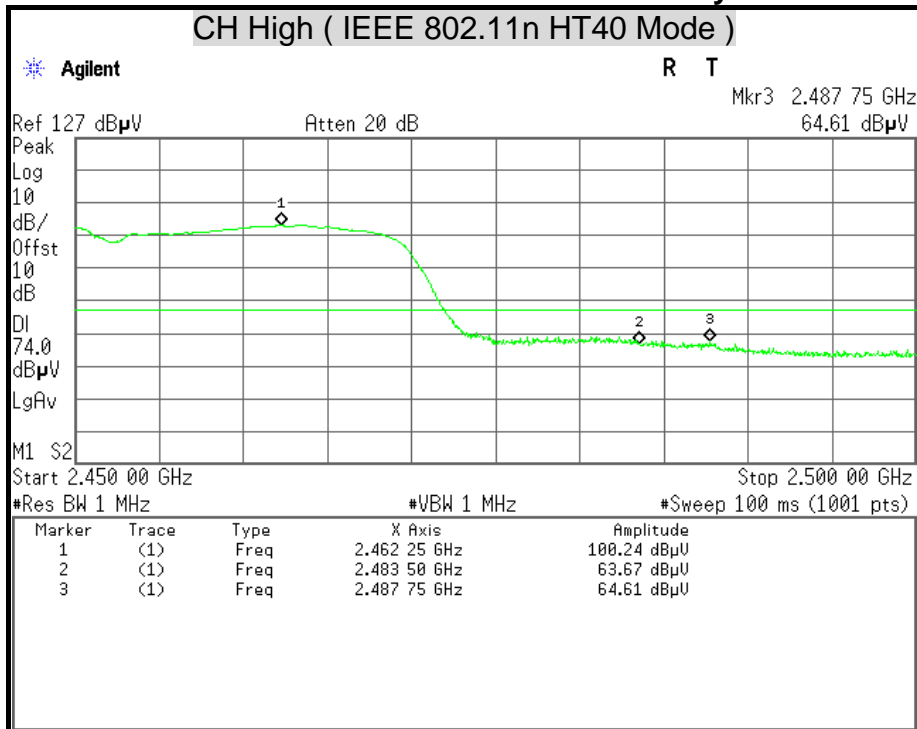

Detector Mode : Average

Polarity : Horizontal

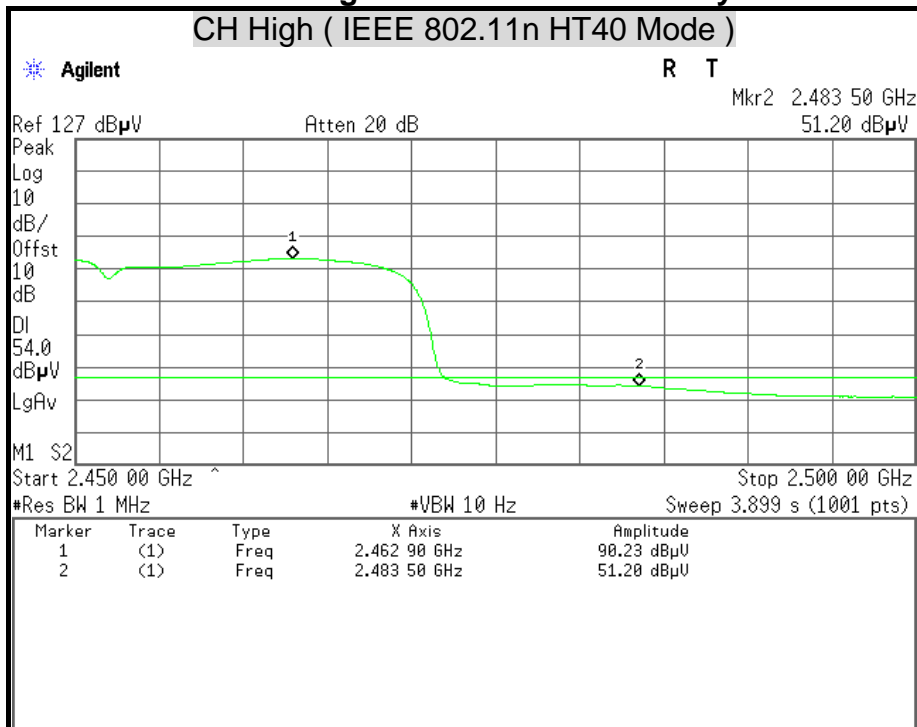



Detector Mode : Peak

Polarity : Vertical

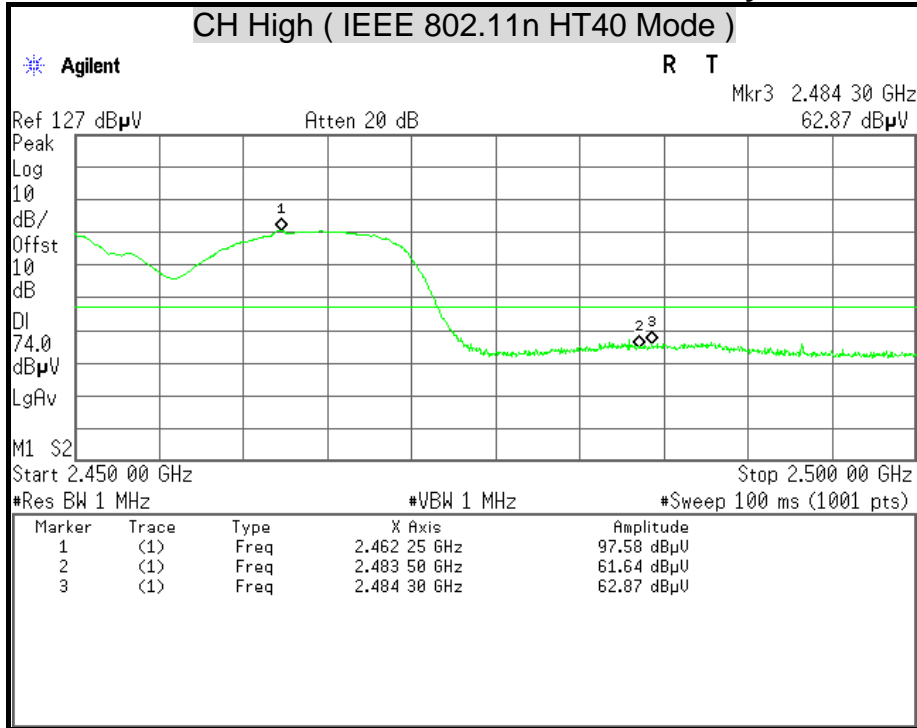

Detector Mode : Average

Polarity : Vertical

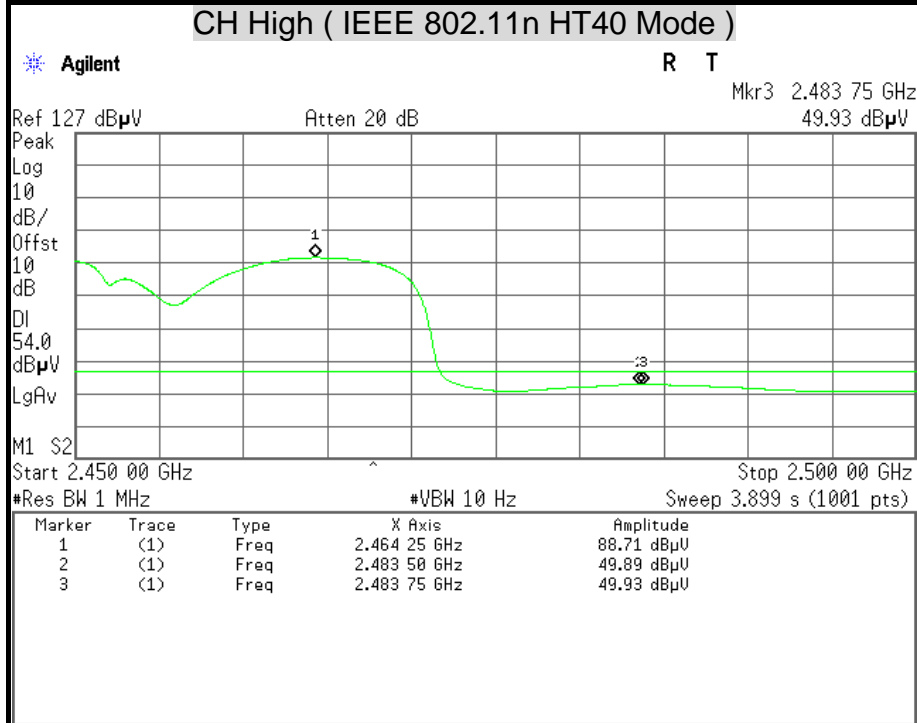



7.7 CONDUCTED EMISSION

LIMITS

§ 15.207 (a) Except as shown in paragraph (b) and (c) this section, for an intentional radiator that is designed to be connected to the public utility (AC) power line, the radio frequency voltage that is conducted back onto the AC power line on any frequency or frequencies within the band 150 kHz to 30 MHz shall not exceed the limits in the following table, as measured using a 50 μ H/50 ohms line impedance stabilization network (LISN). Compliance with the provisions of this paragraph shall be based on the measurement of the radio frequency voltage between each power line and ground at the power terminal. The lower limit applies at the boundary between the frequency ranges.

Frequency Range (MHz)	Conducted Limit (dB μ v)	
	Quasi-peak	Average
0.15 - 0.50	66 to 56	56 to 46
0.50 - 5.00	56	46
5.00 - 30.0	60	50

TEST EQUIPMENT

Name of Equipment	Manufacturer	Model	Serial Number	Calibration Due
L.I.S.N	SCHWARZBECK	NSLK 8127	8127-465	08/09/2012
L.I.S.N	SCHWARZBECK	NSLK 8127	8127-473	03/14/2012
EMI Receiver	ROHDE & SCHWARZ	ESCS 30	835418/008	10/24/2011
Pulse Limit	ROHDE & SCHWARZ	ESH3-Z2	100117	09/14/2012

Remark: Each piece of equipment is scheduled for calibration once a year.



TEST SETUP

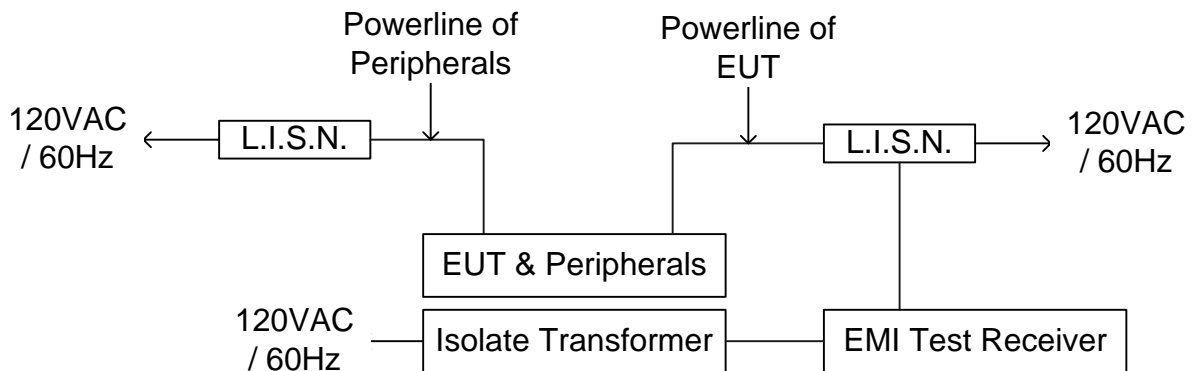
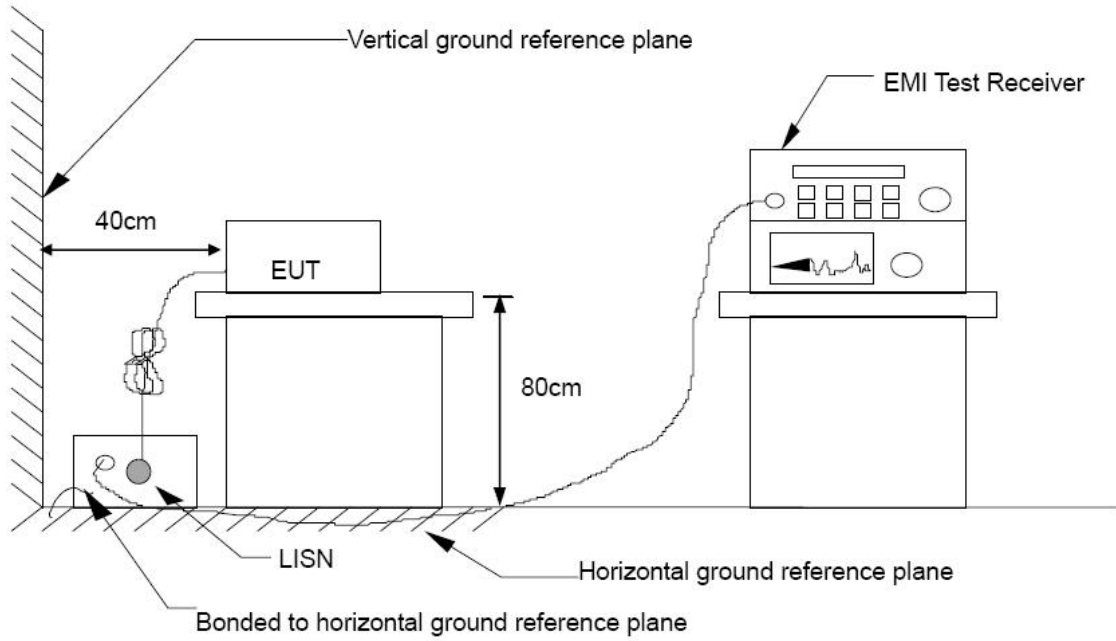



TEST PROCEDURE

The basic test procedure was in accordance with ANSI C63.4:2003.

The test procedure is performed in a 4m × 3m × 2.4m (L×W×H) shielded room.

The EUT along with its peripherals were placed on a 1.0m (W) × 1.5m (L) and 0.8m in height wooden table and the EUT was adjusted to maintain a 0.4 meter space from a vertical reference plane.

The EUT was connected to power mains through a line impedance stabilization network (LISN) which provides 50 ohm coupling impedance for measuring instrument and the chassis ground was bounded to the horizontal ground plane of shielded room. All peripherals were connected to the second LISN and the chassis ground also bounded to the horizontal ground plane of shielded room.

The EUT was located so that the distance between the boundary of the EUT and the closest surface of the LISN is 0.8 m. Where a mains flexible cord was provided by the manufacturer shall be 1 m long, or if in excess of 1 m, the excess cable was folded back and forth as far as possible so as to form a bundle not exceeding 0.4 m in length.



TEST RESULTS

Product Name	8x4 D3 Wireless Router	Test By	Waternil Guan
Test Model	CGN2-ROG01129	Test Date	2011/09/21
Test Mode	Normal Operating	Temp. & Humidity	24.1°C, 52%

LINE

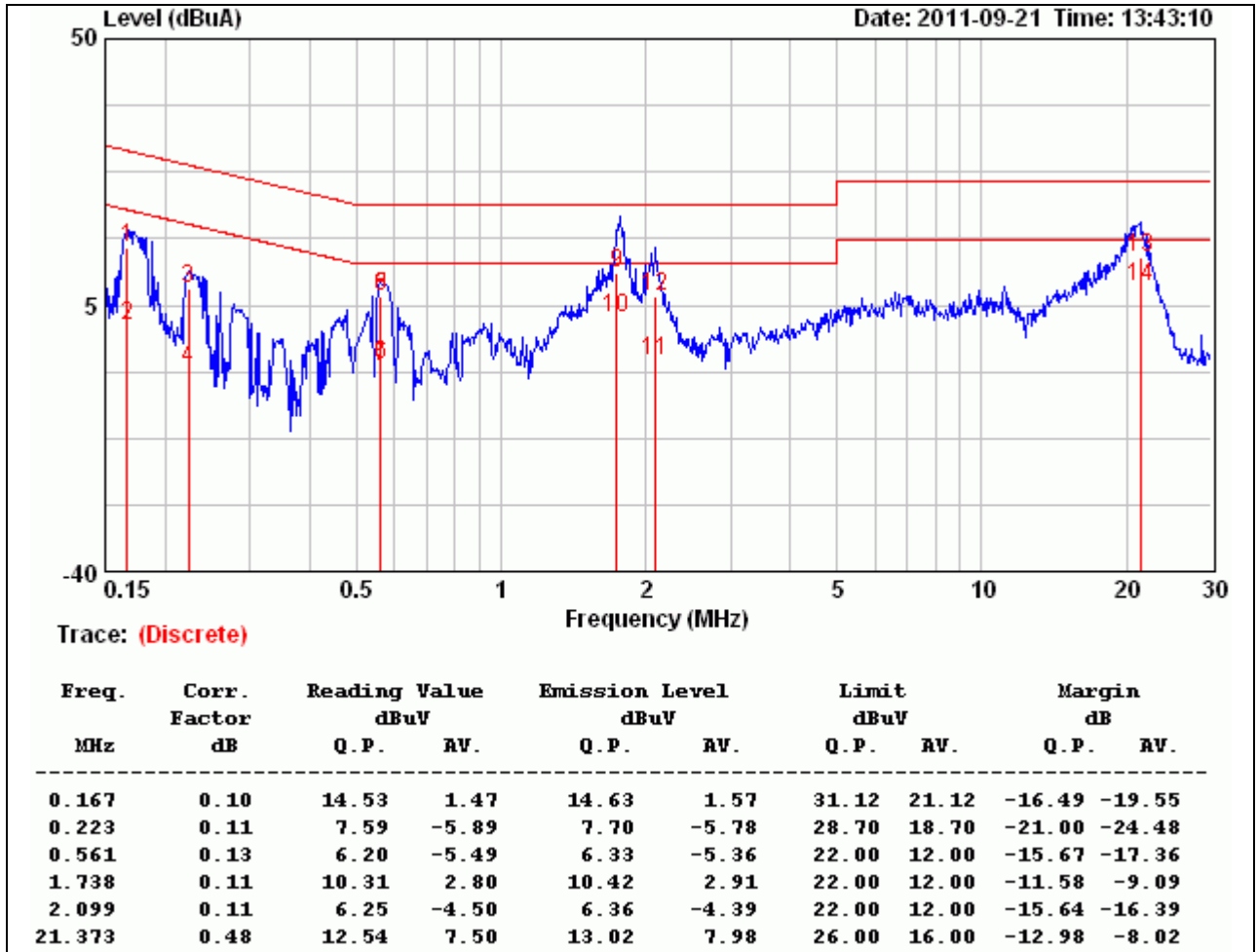

Remark:

1. Correction Factor = Insertion loss + Cable loss
2. Emission level = Reading Value + Correction factor
3. Margin value = Emission level - Limit value



Product Name	8x4 D3 Wireless Router	Test By	Waternil Guan
Test Model	CGN2-ROG01129	Test Date	2011/09/21
Test Mode	Normal Operating	Temp. & Humidity	24.1°C, 52%

NEUTRAL

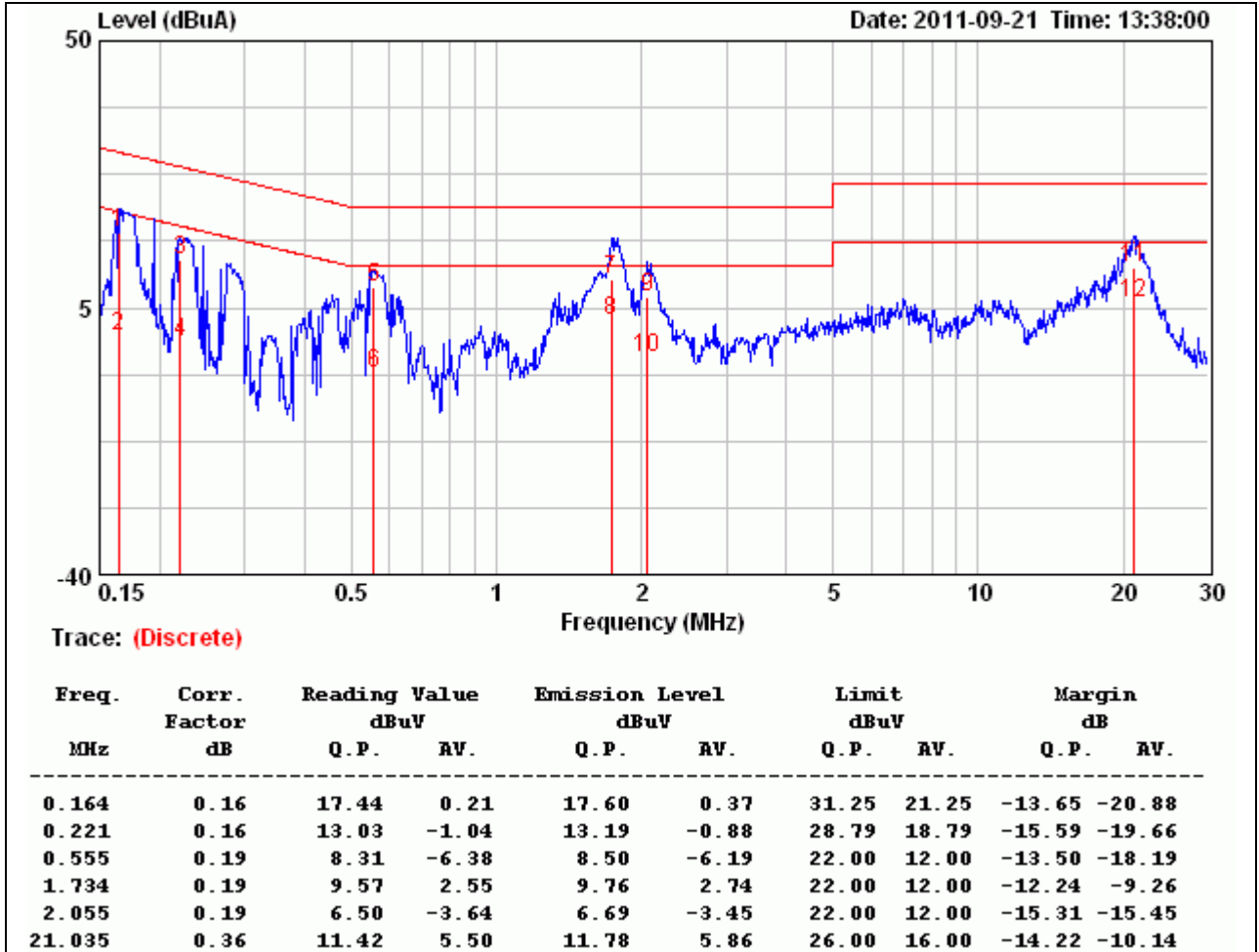

Remark:

1. Correction Factor = Insertion loss + Cable loss
2. Emission level = Reading value + Correction factor
3. Margin value = Emission level - Limit value



APPENDIX I MAXIMUM PERMISSIBLE EXPOSURE

According to FCC 1.1310 : The criteria listed in the following table shall be used to evaluate the environment impact of human exposure to radio frequency (RF) radiation as specified in 1.1307(b) LIMITS FOR MAXIMUM PERMISSIBLE EXPOSURE (MPE)

Frequency Range (MHz)	Electric Field Strength (V/m)	Magnetic Field Strength (A/m)	Power Density (mW/cm ²)	Average Time
(A) Limits for Occupational / Control Exposures				
300-1,500	--	--	F/300	6
1,500-100,000	--	--	5	6
(B) Limits for General Population / Uncontrol Exposures				
300-1,500	--	--	F/1500	6
1,500-100,000	--	--	1	30

CALCULATIONS

Given $E = \frac{\sqrt{30 \times P \times G}}{d}$ & $S = \frac{E^2}{3770}$

Where E = Field strength in Volts / meter

P = Power in Watts

G = Numeric antenna gain

d = Distance in meters

S = Power density in milliwatts / square centimeter

Combining equations and re-arranging the terms to express the distance as a function of the remaining variables yields:

$$S = \frac{30 \times P \times G}{3770d^2}$$

Changing to units of mW and cm, using:

$$P \text{ (mW)} = P \text{ (W)} / 1000 \text{ and}$$

$$d \text{ (cm)} = d \text{ (m)} / 100$$

Yields

$$S = \frac{30 \times (P/1000) \times G}{3770 \times (d/100)^2} = 0.0796 \times \frac{P \times G}{d^2}$$

Where d = Distance in cm

P = Power in mW

G = Numeric antenna gain

S = Power density in mW / cm²



LIMIT

Power Density Limit, $S=1.0\text{mW}/\text{cm}^2$

TEST RESULTS

Mode	Antenna Gain (dBi)	Minimum separation distance (cm)	Output Power (dBm)	Numeric antenna gain (mW)	Power Density Limit (mW/cm^2)	Power Density at 20cm (mW/cm^2)
IEEE 802.11b	4.73	20.0	10.19	2.97	1.00	0.006176
IEEE 802.11g	4.73	20.0	13.40	2.97	1.00	0.012934
IEEE 802.11n HT20	7.21	20.0	15.74	5.26	1.00	0.039239
IEEE 802.11n HT40	7.21	20.0	17.12	5.26	1.00	0.053916

Remark: For mobile or fixed location transmitters, the maximum power density is $1.0\text{ mW}/\text{cm}^2$ even if the calculation indicates that the power density would be larger.