

## TEST REPORT

Test report no.: 1-2904/16-01-02-B



### Testing laboratory

**CTC advanced GmbH**

Untertuerkheimer Strasse 6 – 10

66117 Saarbruecken / Germany

Phone: + 49 681 5 98 - 0

Fax: + 49 681 5 98 - 9075

Internet: <http://www.ctcadvanced.com>

e-mail: [mail@ctcadvanced.com](mailto:mail@ctcadvanced.com)

**Accredited Testing Laboratory:**

The testing laboratory (area of testing) is accredited according to DIN EN ISO/IEC 17025 (2005) by the Deutsche Akkreditierungsstelle GmbH (DAkkS)

The accreditation is valid for the scope of testing procedures as stated in the accreditation certificate with the registration number: D-PL-12076-01-01

### Applicant

**Datalogic S.r.l.**

Via San Vitalino, 13

40012 Lippo di Calderara di Reno (Bologna) / ITALY

Phone: +39 05 13 14 70 11

Contact: Eucarpio Guarisco

e-mail: [eucarpio.guarisco@datalogic.com](mailto:eucarpio.guarisco@datalogic.com)

Phone: +39 05 13 14 72 85

### Manufacturer

**Datalogic S.r.l.**

Via San Vitalino, 13

40012 Lippo di Calderara di Reno (Bologna) / ITALY

### Test standard/s

47 CFR Part 15 Title 47 of the Code of Federal Regulations; Chapter I; Part 15 - Radio frequency devices

RSS - 247 Issue 2 Digital Transmission Systems (DTSs), Frequency Hopping Systems (FHSs) and Licence - Exempt Local Area Network (LE-LAN) Devices

RSS - Gen Issue 4 Spectrum Management and Telecommunications Radio Standards Specifications - General Requirements and Information for the Certification of Radio Apparatus

For further applied test standards please refer to section 3 of this test report.

### Test Item

**Kind of test item:** Mobile Computer

**Model name:** SKORPIO X4

**FCC ID:** U4GSX4WB

**IC:** 3862E-SX4WB

**Frequency:** RLAN bands  
5150 MHz to 5250 MHz; 5250 MHz to 5350 MHz;  
5470 MHz to 5725 MHz

**Technology tested:** WLAN (OFDM/a-mode; n/ac HT20- & n/ac HT40-mode)

**Antenna:** Integrated antenna

**Power supply:** 3.7 V DC by Li-Ion battery

**Temperature range:** -20°C to +50°C



This test report is electronically signed and valid without handwriting signature. For verification of the electronic signatures, the public keys can be requested at the testing laboratory.

### Test report authorized:

René Oelmann  
Lab Manager  
Radio Communications & EMC

### Test performed:

David Lang  
Lab Manager  
Radio Communications & EMC

## 1 Table of contents

<b>1</b>	<b>Table of contents</b> .....	<b>2</b>
<b>2</b>	<b>General information</b> .....	<b>3</b>
2.1	<b>Notes and disclaimer</b> .....	<b>3</b>
2.2	<b>Application details</b> .....	<b>3</b>
2.3	<b>Test laboratories sub-contracted</b> .....	<b>3</b>
<b>3</b>	<b>Test standard/s and references</b> .....	<b>4</b>
<b>4</b>	<b>Test environment</b> .....	<b>5</b>
<b>5</b>	<b>Test item</b> .....	<b>5</b>
5.1	<b>General description</b> .....	<b>5</b>
5.2	<b>Additional information</b> .....	<b>5</b>
<b>6</b>	<b>Measurement uncertainty</b> .....	<b>6</b>
<b>7</b>	<b>Summary of measurement results</b> .....	<b>7</b>
<b>8</b>	<b>Additional comments</b> .....	<b>8</b>
<b>9</b>	<b>RF measurements</b> .....	<b>9</b>
<b>9.1</b>	<b>Description of test setup</b> .....	<b>9</b>
9.1.1	Conducted measurements .....	<b>9</b>
<b>9.2</b>	<b>Parameters of DFS test signals</b> .....	<b>11</b>
9.2.1	DFS Detection Thresholds for Master Devices as well as Client Devices With Radar Detection .....	<b>11</b>
9.2.2	DFS Response Requirement Values .....	<b>11</b>
9.2.3	Radar Test Waveforms .....	<b>12</b>
<b>9.3</b>	<b>Test preparation</b> .....	<b>15</b>
9.3.1	Channel loading .....	<b>15</b>
9.3.2	Radar burst timing signal .....	<b>16</b>
<b>9.4</b>	<b>Test results (during normal operation)</b> .....	<b>17</b>
9.4.1	Channel move time / channel closing transmission time .....	<b>17</b>
9.4.2	Non-Occupancy Period .....	<b>19</b>
<b>10</b>	<b>Observations</b> .....	<b>20</b>
<b>Annex A</b>	<b>Document history</b> .....	<b>20</b>
<b>Annex B</b>	<b>Further information</b> .....	<b>20</b>
<b>Annex C</b>	<b>Accreditation Certificate</b> .....	<b>21</b>

## 2 General information

### 2.1 Notes and disclaimer

The test results of this test report relate exclusively to the test item specified in this test report. CTC advanced GmbH does not assume responsibility for any conclusions and generalizations drawn from the test results with regard to other specimens or samples of the type of the equipment represented by the test item.

The test report may only be reproduced or published in full. Reproduction or publication of extracts from the report requires the prior written approval of CTC advanced GmbH.

The testing service provided by CTC advanced GmbH has been rendered under the current "General Terms and Conditions for CTC advanced GmbH".

CTC advanced GmbH will not be liable for any loss or damage resulting from false, inaccurate, inappropriate or incomplete product information provided by the customer.

Under no circumstances does the CTC advanced GmbH test report include any endorsement or warranty regarding the functionality, quality or performance of any other product or service provided.

Under no circumstances does the CTC advanced GmbH test report include or imply any product or service warranties from CTC advanced GmbH, including, without limitation, any implied warranties of merchantability, fitness for purpose, or non-infringement, all of which are expressly disclaimed by CTC advanced GmbH.

All rights and remedies regarding vendor's products and services for which CTC advanced GmbH has prepared this test report shall be provided by the party offering such products or services and not by CTC advanced GmbH. In no case this test report can be considered as a Letter of Approval.

This test report is electronically signed and valid without handwritten signature. For verification of the electronic signatures, the public keys can be requested at the testing laboratory.

**This test report replaces the test report with the number 1-2904/16-01-02-A and dated 2017-06-09**

### 2.2 Application details

Date of receipt of order:	2017-04-11
Date of receipt of test item:	2017-05-19
Start of test:	2017-05-19
End of test:	2017-05-19
Person(s) present during the test:	-/-

### 2.3 Test laboratories sub-contracted

None

### 3 Test standard/s and references

Test standard	Date	Description
47 CFR Part 15		Title 47 of the Code of Federal Regulations; Chapter I; Part 15 - Radio frequency devices
RSS - 247 Issue 2	February 2017	Digital Transmission Systems (DTSs), Frequency Hopping Systems (FHSs) and Licence - Exempt Local Area Network (LE-LAN) Devices
RSS - Gen Issue 4	November 2014	Spectrum Management and Telecommunications Radio Standards Specifications - General Requirements and Information for the Certification of Radio Apparatus

Guidance	Version	Description
UNII: KDB 789033 D02	v01r04	Guidelines for Compliance Testing of Unlicensed National Information Infrastructure (U-NII) Devices - Part 15, Subpart E
ANSI C63.4-2014	-/-	American national standard for methods of measurement of radio-noise emissions from low-voltage electrical and electronic equipment in the range of 9 kHz to 40 GHz
ANSI C63.10-2013	-/-	American national standard of procedures for compliance testing of unlicensed wireless devices
UNII: KDB 905462 D02	v02	Compliance measurement procedures for unlicensed - national information infrastructure devices operating in the 5250 - 5350 MHz and 5470 - 5725 MHz bands incorporating dynamic frequency selection
UNII: KDB 905462 D03	v01r02	Client Without DFS New Rules
UNII: KDB 905462 D04	v01	Operational Modes for DFS Testing New Rules

## 4 Test environment

Temperature	:	$T_{nom}$ -22 °C during room temperature tests $T_{max}$ +50 °C during high temperature tests $T_{min}$ -20 °C during low temperature tests
Relative humidity content	:	52 %
Barometric pressure	:	986 hpa
Power supply	:	$V_{nom}$ 3.7 V DC by Li-Ion battery $V_{max}$ -/- V $V_{min}$ -/- V

## 5 Test item

### 5.1 General description

Kind of test item	:	Mobile Computer
Type identification	:	SKORPIO X4
HMN	:	-/-
PMN	:	SKORPIO X4
HVIN	:	SX4 WB GUN (Pistol Grip variants)
FVIN	:	-/-
S/N serial number	:	Z16P01724
HW hardware status	:	Beta HW version
SW software status	:	2.01.38 (Android 4.4)
Frequency band	:	RLAN bands 5150 MHz to 5250 MHz; 5250 MHz to 5350 MHz; 5470 MHz to 5725 MHz
Type of radio transmission	:	OFDM
Use of frequency spectrum	:	
Type of modulation	:	(D)BPSK, (D)QPSK, 16 – QAM, 64 – QAM
Antenna	:	Integrated antenna
DFS Classification	:	Client device without radar detection
Power supply	:	3.7 V DC by Li-Ion battery
Temperature range	:	-20°C to +50°C

### 5.2 Additional information

The content of the following annexes is defined in the QA. It may be that not all of the listed annexes are necessary for this report, thus some values in between may be missing.

Test setup- and EUT-photos are included in test report:

- 1-2904/16-01-01\_AnnexA
- 1-2904/16-01-01\_AnnexB
- 1-2904/16-01-01\_AnnexH

## 6 Measurement uncertainty

Measurement uncertainty	
Test case	Uncertainty
Frequency accuracy (radar burst)	0.1 Hz
Level accuracy (radar burst)	± 0.8 dB

## 7 Summary of measurement results

<input type="checkbox"/>	No deviations from the technical specifications were ascertained
<input type="checkbox"/>	There were deviations from the technical specifications ascertained
<input checked="" type="checkbox"/>	This test report is only a partial test report. The content and verdict of the performed test cases are listed below.

TC Identifier	Description	Verdict	Date	Remark
DFS-Testing	CFR Part 15, FCC 06-96	Pass	2017-06-21	DFS only

Test Standard Clause	Test Case	Bandwidth	C	NC	NA	NP	Remark
7.8.1*3	U-NII Detection Bandwidth	-/-	<input type="checkbox"/>	<input type="checkbox"/>	<input checked="" type="checkbox"/>	<input type="checkbox"/>	*3
§15.407 (h)(2)	DFS Detection Threshold	-/-	<input type="checkbox"/>	<input type="checkbox"/>	<input checked="" type="checkbox"/>	<input type="checkbox"/>	*3
§15.407 (h)(2) (ii) & 7.8.2*3	Channel Availability Check Time	-/-	<input type="checkbox"/>	<input type="checkbox"/>	<input checked="" type="checkbox"/>	<input type="checkbox"/>	*3
§15.407 (h)(2) (iv) & 7.8.3*3	Non-Occupancy Period	40 MHz	<input checked="" type="checkbox"/>	<input type="checkbox"/>	<input type="checkbox"/>	<input type="checkbox"/>	*1
§15.407 (h)(2) (iii) & 7.8.2*3	Channel Move Time / Channel Closing Transmission Time	40 MHz	<input checked="" type="checkbox"/>	<input type="checkbox"/>	<input type="checkbox"/>	<input type="checkbox"/>	*2
7.8.3 & 7.8.4*3	In-Service Monitoring / Statistical Performance Check	-/-	<input type="checkbox"/>	<input type="checkbox"/>	<input checked="" type="checkbox"/>	<input type="checkbox"/>	*3

### Abbreviations/References:

- C Compliant
- NC Not compliant
- NA Not applicable
- NP Not performed
- \*1 Prior to use of a channel
- \*2 During normal operation
- \*3 Not applicable for Client Devices without radar detection.

## 8 Additional comments

Reference documents:           None

Special test descriptions:       All tests except the In-Service Monitoring are conducted with Pulse Type 0.  
  
A sample with temporary antenna connector was provided to perform the measurements in a conducted way.

Configuration descriptions:    Iperf was used to generate the required channel load (duty cycle greater 17 percent).

DFS functionality:                Master device  
                                      Client with radar detection  
                                      Client without radar detection



## 9 RF measurements

### 9.1 Description of test setup

#### 9.1.1 Conducted measurements

##### Setup

Figure 1 shows a setup whereby the UUT is a RLAN device operating in slave mode, without Radar Interference Detection function. This setup also contains a RLAN device operating in master mode. The radar test signals are injected into the master device. The UUT (slave device) is associated with the master device.

Figure 1 shows an example

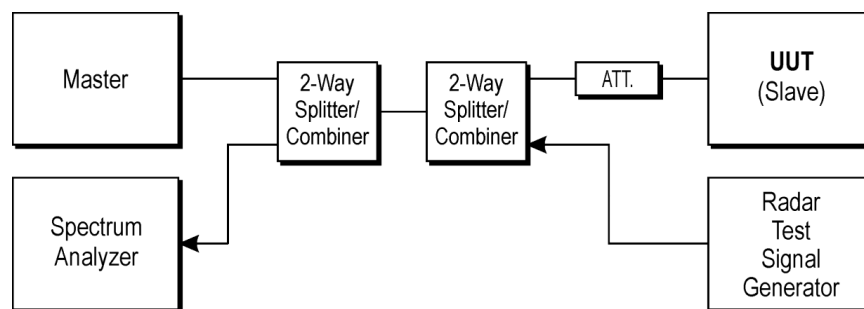

Figure 1: Setup

$$RPP = SG - CA$$

(RPP-radar pulse power; SG-signal generator power; CA-loss signal path)

Example calculation:

$$RPP [dBm] = -30.0 [dBm] - 33.0 [dB] = -63.0 [dBm]$$

**Equipment table:**

No.	Lab / Item	Equipment	Type	Manufacturer	Serial No.	INV. No.	Kind of Calibration	Last Calibration	Next Calibration
1	A	Vector Signal Generator	SMU200A	R&S	101633	300003496	k	24.01.2017	23.01.2020
2	A	Spectrum Analyzer 9kHz to 30GHz - 140..+30dBm	FSP30	R&S	100886	300003575	k	24.01.2017	23.01.2019
3	A	Notebook	Latitude 15 6000 Series	Dell		300004737	ne	-/-	-/-
4	A*	Dual Band Gigabit Router	RT-AC68U	Asus	F11MOH056666	400001244	ne	-/-	-/-
5	A	PC	ExOne	F+W	2890296v001	300005102	ne	-/-	-/-
6	A	RF-Cable DFS-Tester No. 1	Enviroflex 316 D	Huber & Suhner	Batch no. 1560522	400001257	ev	-/-	-/-
7	A	RF-Cable DFS-Tester No. 2	Enviroflex 316 D	Huber & Suhner	Batch no. 1560522	400001258	ev	-/-	-/-
8	A	RF-Cable DFS-Tester No. 3	Enviroflex 316 D	Huber & Suhner	Batch no. 1560522	400001259	ev	-/-	-/-
9	A	RF-Cable DFS-Tester No. 5	Enviroflex 316 D	Huber & Suhner	Batch no. 1560522	400001261	ev	-/-	-/-
10	A	RF-Cable DFS-Tester No. 6	Enviroflex 316 D	Huber & Suhner	Batch no. 1560522	400001262	ev	-/-	-/-

\* FCC ID: MSQ-RTAC68U

**Agenda:** Kind of Calibration

- |      |  |     |  |
|------|--|-----|--|
| k    | calibration / calibrated                   | EK  | limited calibration                                  |
| ne   | not required (k, ev, izw, zw not required) | zw  | cyclical maintenance (external cyclical maintenance) |
| ev   | periodic self verification                 | izw | internal cyclical maintenance                        |
| Ve   | long-term stability recognized             | g   | blocked for accredited testing                       |
| vlk! | Attention: extended calibration interval   | *)  | next calibration ordered / currently in progress     |
| NK!  | Attention: not calibrated                  |     |  |

## 9.2 Parameters of DFS test signals

### 9.2.1 DFS Detection Thresholds for Master Devices as well as Client Devices With Radar Detection

Maximum Transmit Power EIRP	Value (see note)
≥ 200 mW	-64 dBm
< 200 mW and power spectral density < 10 dBm/MHz	-62 dBm
< 200 mW and that do not meet the power spectral density < 10 dBm/MHz	-64 dBm

Note 1: This is the level at the input of the receiver assuming a 0 dBi receive antenna.  
 Note 2: Throughout these test procedures an additional 1 dB has been added to the amplitude of the test transmission waveforms to account for variations in measurement equipment. This will ensure that the test signal is at or above the detection threshold level to trigger a DFS response.  
 Note3: EIRP is based on the highest antenna gain. For MIMO devices refer to KDB Publication 662911 D01.

### 9.2.2 DFS Response Requirement Values

Parameter	Value
Non-occupancy period	minimum 30 minutes
Channel Availability Check Time	60 seconds
Channel Move Time	10 seconds See Note 1.
Channel Closing Transmission Time	200 milliseconds + an aggregate of 60 milliseconds over remaining 10 second period. See Notes 1 and 2.
U-NII Detection Bandwidth	Minimum 100% of the U-NII 99% transmission power bandwidth. See Note 3.

Note 1: Channel Move Time and the Channel Closing Transmission Time should be performed with Radar Type 0. The measurement timing begins at the end of the Radar Type 0 burst.  
 Note 2: The Channel Closing Transmission Time is comprised of 200 milliseconds starting at the beginning of the Channel Move Time plus any additional intermittent control signals required to facilitate a Channel move (an aggregate of 60 milliseconds) during the remainder of the 10 second period. The aggregate duration of control signals will not count quiet periods in between transmissions.  
 Note 3: During the U-NII Detection Bandwidth detection test, radar type 0 should be used. For each frequency step the minimum percentage of detection is 90 percent. Measurements are performed with no data traffic.

### 9.2.3 Radar Test Waveforms

This section provides the parameters for required test waveforms, minimum percentage of successful detections, and the minimum number of trials that must be used for determining DFS conformance.

#### Short Pulse Radar Test Waveforms

Radar Type	Pulse Width (µsec)	PRI (µsec)	Number of Pulses	Minimum Percentage of Successful Detection	Minimum Number of Trials
0	1	1428	18	See Note 1	See Note 1
1	1	Test A: 15 unique PRI values randomly selected from the list of 23 PRI values in Table 5a	Roundup $\left\{ \left( \frac{1}{360} \right) \cdot \left( \frac{19 \cdot 10^6}{PRI_{\mu sec}} \right) \right\}$	60%	30
		Test B: 15 unique PRI values randomly selected within the range of 518-3066 µsec, with a minimum increment of 1 µsec, excluding PRI values selected in Test A			
2	1-5	150-230	23-29	60%	30
3	6-10	200-500	16-18	60%	30
4	11-20	200-500	12-16	60%	30
Aggregate (Radar Types 1-4)				80%	120
Note 1: Short Pulse Radar Type 0 should be used for the detection bandwidth test, channel move time, and channel closing time tests.					

A minimum of 30 unique waveforms are required for each of the Short Pulse Radar Types 2 through 4.

**Pulse Repetition Intervals Values for Test A**

Pulse Repetition Frequency Number	Pulse Repetition Frequency (Pulses Per Second)	Pulse Repetition Interval (Microseconds)
1	1930.5	518
2	1858.7	538
3	1792.1	558
4	1730.1	578
5	1672.2	598
6	1618.1	618
7	1567.4	638
8	1519.8	658
9	1474.9	678
10	1432.7	698
11	1392.8	718
12	1355	738
13	1319.3	758
14	1285.3	778
15	1253.1	798
16	1222.5	818
17	1193.3	838
18	1165.6	858
19	1139	878
20	1113.6	898
21	1089.3	918
22	1066.1	938
23	326.2	3066

**Long Pulse Radar Test Waveform**

Radar Type	Pulse Width (µsec)	Chirp Width (MHz)	PRI (µsec)	Number of Pulses per Burst	Number of Bursts	Minimum Percentage of Successful Detection	Minimum Number of Trails
5	50-100	5-20	1000-2000	1-3	8-20	80%	30

The parameters for this waveform are randomly chosen. Thirty unique waveforms are required for the Long Pulse Radar Type waveforms.

**Frequency Hopping Radar Test Waveform**

Radar Type	Pulse Width (µsec)	Chirp Width (MHz)	Pulses per Hop	Hopping Rate (kHz)	Hopping Sequence Length (msec)	Minimum Percentage of Successful Detection	Minimum Number of Trails
6	1	333	9	0.333	300	70%	30

For the Frequency Hopping Radar Type, the same Burst parameters are used for each waveform. The hopping sequence is different for each waveform and a 100-length segment is selected from the hopping sequence defined.

The first frequency in a hopping sequence is selected randomly from the group of 475 integer frequencies from 5250 – 5724 MHz. Next, the frequency that was just chosen is removed from the group and a frequency is randomly selected from the remaining 474 frequencies in the group. This process continues until all 475 frequencies are chosen for the set.

## 9.3 Test preparation

### 9.3.1 Channel loading

Timing plots are required with calculations demonstrating a minimum channel loading of approximately 17% or greater. For example, channel loading can be estimated by setting the spectrum analyzer for zero span and approximate the Time On/ (Time On + Off Time). This can be done with any appropriate channel BW and modulation type.

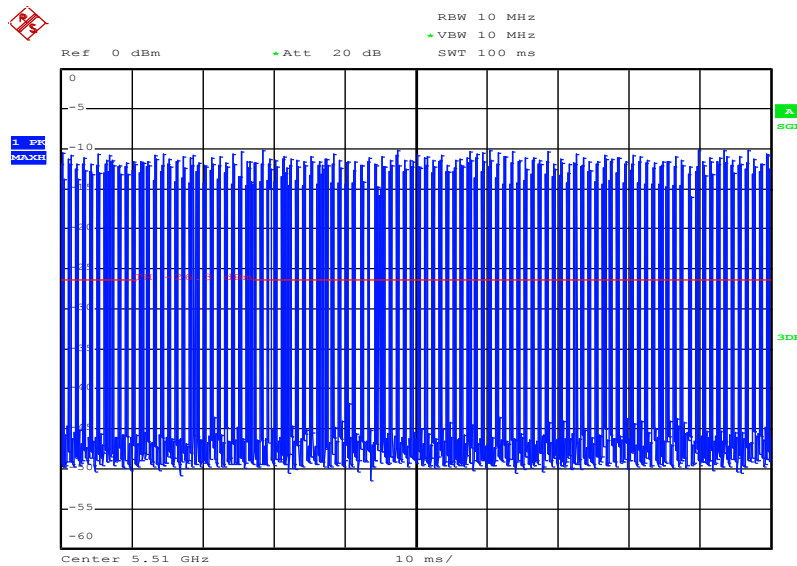

Date: 19.MAY.2017 14:22:12

Plot 1: HT40-Mode: Calculated duty cycle = 28%

### 9.3.2 Radar burst timing signal

To accurately determine the channel closing time and channel closing transmission time the spectrum analyser is triggered at the end of the radar burst (see marker at  $t = 0\text{ms}$ ).

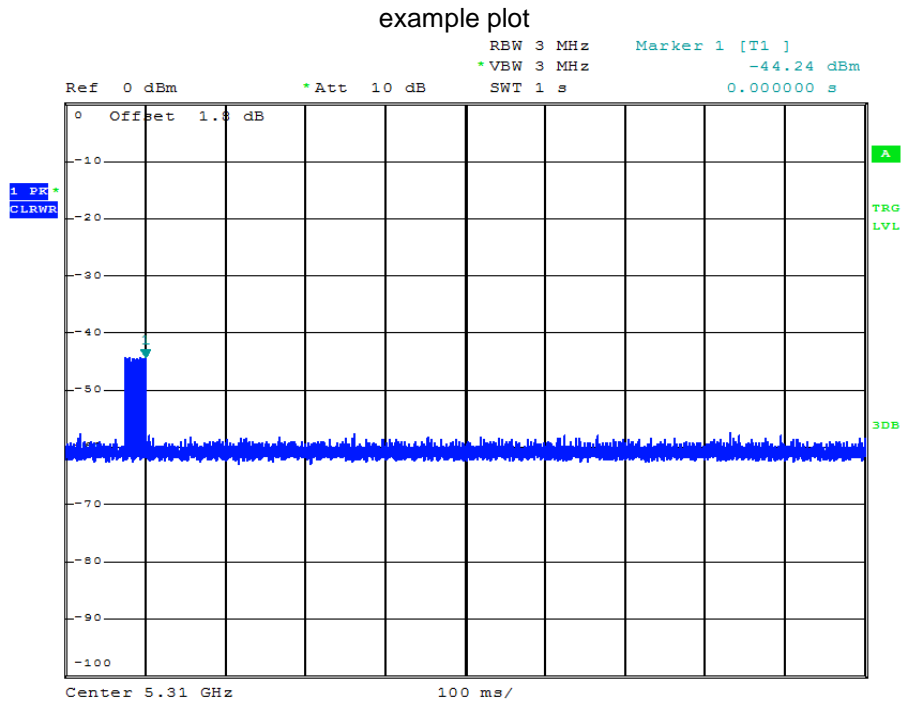

Plot 2: example plot





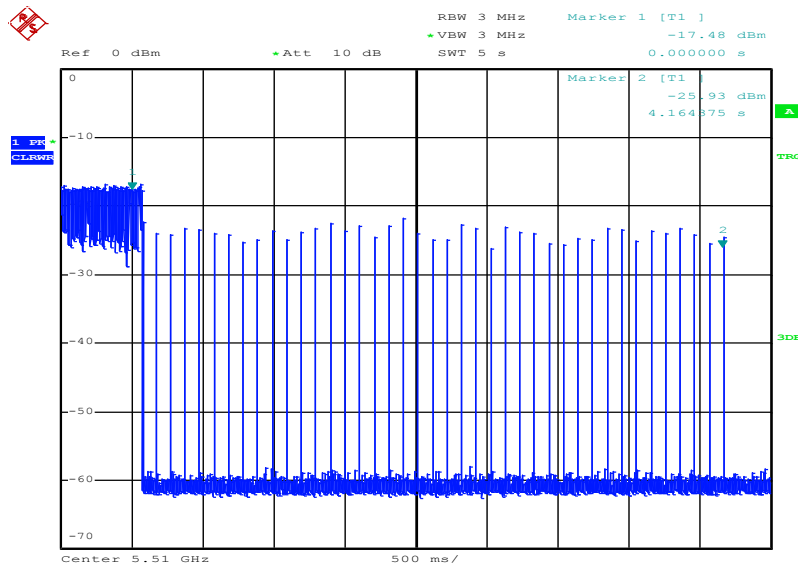

Date: 19.MAY.2017 14:30:25

Plot 4: Channel Closing Transmission Time

Note: The accumulated transmission time is calculated by the number of bins occurring after  $t = 0$ ms multiplied with the Time-per-sweep point-factor resulting from the Sweep Time and number of Sweep Points of the Spectrum Analyser.

The Channel Closing Transmission Time is 41.9ms.

### 9.4.2 Non-Occupancy Period

A channel that has been flagged as containing a radar system, either by a channel availability check or in-service monitoring, is subject to a non-occupancy period of at least 30 minutes. The non occupancy period starts at the time when the radar system is detected.

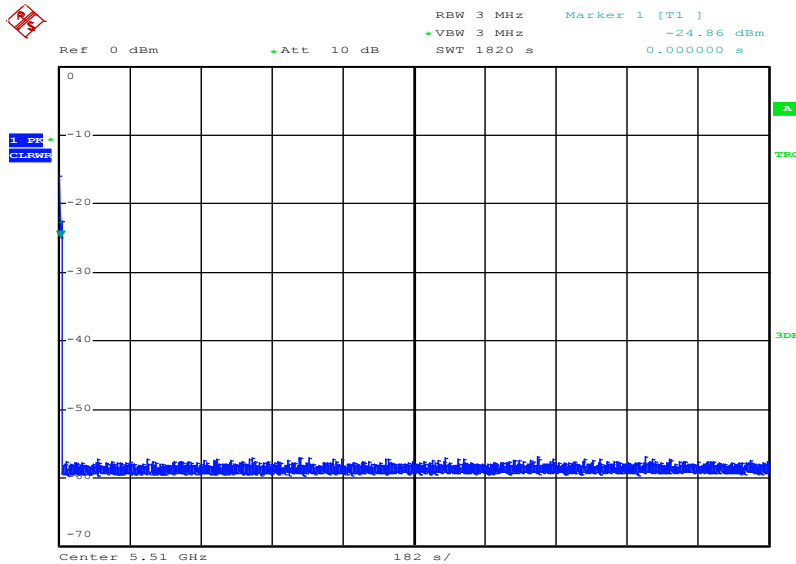

Date: 19.MAY.2017 17:07:39

Plot 5: Non-Occupancy Period

## 10 Observations

No observations except those reported with the single test cases have been made.

## Annex A Document history

Version	Applied changes	Date of release
	Initial release	2017-06-07
-A	Applicant's and manufacturer's name revised	2017-06-09
-B	HW/SW revision information added	2017-06-21

## Annex B Further information

### Glossary

AVG	-	Average
DUT	-	Device under test
EMC	-	Electromagnetic Compatibility
EN	-	European Standard
EUT	-	Equipment under test
ETSI	-	European Telecommunications Standard Institute
FCC	-	Federal Communication Commission
FCC ID	-	Company Identifier at FCC
HW	-	Hardware
IC	-	Industry Canada
Inv. No.	-	Inventory number
N/A	-	Not applicable
PP	-	Positive peak
QP	-	Quasi peak
S/N	-	Serial number
SW	-	Software
PMN	-	Product marketing name
HMN	-	Host marketing name
HVIN	-	Hardware version identification number
FVIN	-	Firmware version identification number
OBW		Occupied Bandwidth
OC		Operating Channel
OCW		Operating Channel Bandwidth
OOB		Out Of Band

**Annex C Accreditation Certificate**

first page

last page



Deutsche Akkreditierungsstelle GmbH

Befehlener gemäß § 8 Absatz 1 AkkStelleG i.V.m. § 1 Absatz 1 AkkStelleGBV  
Unterzeichnerin der Multilateralen Abkommen  
von EA, ILAC und IAF zur gegenseitigen Anerkennung

**Akkreditierung**



Die Deutsche Akkreditierungsstelle GmbH bestätigt hiermit, dass das Prüflaboratorium

**CTC advanced GmbH**  
Untertürkheimer Straße 6-10, 66117 Saarbrücken

die Kompetenz nach DIN EN ISO/IEC 17025:2005 besitzt, Prüfungen in folgenden Bereichen durchzuführen:

- Funk**
- Mobilfunk (GSM / DCS) + OTA
- Elektromagnetische Verträglichkeit (EMV)
- Produktsicherheit
- SAR / EMF
- Umwelt
- Smart Card Technology
- Bluetooth\*
- Automotive
- Wi-Fi-Services
- Kanadische Anforderungen
- US-Anforderungen
- Akustik
- Near Field Communication (NFC)

Die Akkreditierungsurkunde gilt nur in Verbindung mit dem Bescheid vom 25.11.2016 mit der Akkreditierungsnummer D-PL-12076-01 und ist gültig bis 17.01.2018. Sie besteht aus diesem Deckblatt, der Rückseite des Deckblatts und der folgenden Anlage mit insgesamt 63 Seiten.

Registrierungsnummer der Urkunde: D-PL-12076-01-01

Frankfurt, 25.11.2016

Stelle Minister auf der Rückseite

Im Auftrag Dipl.-Ing. Ralf Eigner  
Abteilungsleiter

Deutsche Akkreditierungsstelle GmbH

Standort Berlin  
Spittelmarkt 10  
10117 Berlin

Standort Frankfurt am Main  
Europa-Allee 52  
60327 Frankfurt am Main

Standort Braunschweig  
Bundesallee 100  
38116 Braunschweig

Die auszugsweise Veröffentlichung der Akkreditierungsurkunde bedarf der vorherigen schriftlichen Zustimmung der Deutsche Akkreditierungsstelle GmbH (DAkkS). Ausgenommen davon ist die separate Weiterverbreitung des Deckblattes durch die umseitig genannte Konformitätsbewertungsstelle in unveränderter Form.

Es darf nicht der Anschein erweckt werden, dass sich die Akkreditierung auch auf Bereiche erstreckt, die über den durch die DAkkS bestätigten Akkreditierungsbereich hinausgehen.

Die Akkreditierung erfolgte gemäß des Gesetzes über die Akkreditierungsstelle (AkkStelleG) vom 31. Juli 2009 (BGBl. I S. 2625) sowie der Verordnung (EG) Nr. 765/2008 des Europäischen Parlaments und des Rates vom 9. Juli 2008 über die Vorschriften für die Akkreditierung und Marktüberwachung im Zusammenhang mit der Vermarktung von Produkten (Abt. L 218 vom 9. Juli 2008, S. 30). Die DAkkS ist Unterzeichnerin der Multilateralen Abkommen zur gegenseitigen Anerkennung der European co-operation for Accreditation (EA), des International Accreditation Forum (IAF) und der International Laboratory Accreditation Cooperation (ILAC). Die Unterzeichner dieser Abkommen erkennen ihre Akkreditierungen gegenseitig an.

Der aktuelle Stand der Mitgliedschaft kann folgenden Webseiten entnommen werden:  
EA: [www.european-accreditation.org](http://www.european-accreditation.org)  
ILAC: [www.ilac.org](http://www.ilac.org)  
IAF: [www.iaf.eu](http://www.iaf.eu)

**Note:**  
The current certificate including annex can be received on request.