

PARTIAL TEST REPORT
 No.: 18-1-0050701T04a_C02

According to:
FCC Regulations
 Part 15.205
 Part 15.209
 Part 15.407
ISED-Regulations
 RSS-Gen, Issue 4, RSS-247, Issue 2

for
 Datalogic S.r.l.

Joya Touch A6
A00AN04HLXGT0AN

FCC ID: U4GJTADG
ISED ID: 3862E-JTADG
HVIN JTADG GUN
HVIN JTADG HH







Laboratory Accreditation and Listings		
 <p>Accredited EMC-Test Laboratory</p>	 <p>Industry Canada Reg. No.: 3462D-1 Reg. No.: 3462D-2 Reg. No.: 3462D-3</p>	 <p>Voluntary Controls for Electromagnetic Emissions Reg. No.: R-4552, C-20009, T-20006, G-20013</p>
 <p>AUTHORIZED RF LABORATORY</p>	 <p>Lab Code: 20011130-00</p>	 <p>MRA US-EU 0003</p>
accredited according to DIN EN ISO/IEC 17025		
<p>CETECOM GmbH Laboratory Radio Communications & Electromagnetic Compatibility Im Teelbruch 116 • 45219 Essen • Germany Registered in Essen, Germany, Reg. No.: HRB Essen 8984 Tel.: + 49 (0) 20 54 / 95 19-954 • Fax: + 49 (0) 20 54 / 95 19-964 E-mail: info@cetecom.com • Internet: www.cetecom.com</p>		

Table of Contents

1. SUMMARY OF TEST RESULTS.....	3
1.1. Tests measurement overview according to US CFR Title 47, Subpart 15C and RSS-247, Issue 2	3
1.2. Attestation:.....	6
2. ADMINISTRATIVE DATA	7
2.1. Identification of the testing laboratory	7
2.2. Test location	7
2.3. Organizational items	7
2.4. Applicant’s details	7
2.5. Manufacturer’s details	7
3. EQUIPMENT UNDER TEST (EUT).....	8
3.1. WLAN 5 GHz 802.11a/n Technical Data Of Main EUT as Declared by Applicant	8
3.2. EUT: Type, S/N etc. and short descriptions used in this test report	9
3.3. Auxiliary Equipment (AE): Type, S/N etc. and short descriptions	9
3.4. EUT set-ups	9
3.5. EUT operating modes	9
4. DESCRIPTION OF TEST SYSTEM SET-UP’S	11
4.1. Test system set-up for conducted measurements on antenna port	11
4.2. Test system set-up for radiated magnetic field measurements below 30 MHz	13
4.3. Test system set-up for radiated electric field measurement 30 MHz to 1 GHz	14
4.4. Test system set-up for radiated electric field measurement above 1 GHz	15
5. MEASUREMENTS	16
5.1. Duty-Cycle.....	16
5.2. RF-Parameter - Transmitter Peak output power (conducted and radiated).....	17
5.3. General Limit - Radiated field strength emissions below 30 MHz.....	20
5.4. General Limit - Radiated field strength emissions, 30 MHz - 1 GHz.....	23
5.5. General Limit - Radiated emissions, above 1 GHz.....	25
5.6. RF-Parameter - Radiated Band-Edge compliance measurements.....	28
5.7. Measurement uncertainties	31
6. ABBREVIATIONS USED IN THIS REPORT	32
7. ACCREDITATION DETAILS OF CETECOM’S LABORATORIES AND TEST SITES	32
8. INSTRUMENTS AND ANCILLARY	33
TC”	33
9. VERSIONS OF TEST REPORTS (CHANGE HISTORY)	37

Table of Annex			
Annex No.	Contents	Reference Description	Total Pages
Annex 1	Test results	CETECOM_TR18-1-0050701T04-A1	72
Annex 2	External photographs of EUT	JTA6DG External Pictures	11
Annex 3	Internal photographs of EUT	Internal Pictures JOYA TOUCH A6 DG	8
Annex 4	Test set-up photographs	CETECOM_TR18-1-0050701T02-A4	7
The listed attachments are an integral part of this report.			

1. Summary of test results

The test results apply exclusively to the test samples as presented in this report. The CETECOM GmbH does not assume responsibility for any conclusions and generalizations taken in conjunction with other specimens or samples of the type of the item presented to tests. Also we refer on special conditions which the applicant should fulfill according §2.927 to §2.948, special focus regarding modification of the equipment and availability of sample equipment for market surveillance tests.

The presented Equipment Under Test (in this report, hereinafter referred as EUT) : **Joya Touch** integrates total 1 of pre-certified module **SIMT 1502 (FCC ID: UDV-20170406 and IC: 8430A-20170406)** & supports following technologies :

EUT supported Technologies which are not tested within this test report

EUT supported Technology	Test Report Reference
Bluetooth FHSS (BR-EDR) Modes: 2402 – 2480 MHz	CETECOM_TR18-1-0050701T02a_C01
Bluetooth Low Energy Modes: 2402 – 2480 MHz	CETECOM_TR18-1-0096701T01a_C02
WLAN 802.11b/g/n(HT20) Modes: 2412 – 2462 MHz	CETECOM_TR18-1-0050701T03a_C01

EUT supported Technologies which are tested within this test report

- **WLAN 802.11a/n(HT20) Modes: 5150–5850 MHz**

Following test cases have been performed to show compliance with valid Part 15.205/15.209/15.407 of the FCC CFR Title 47 Rules, Edition October 2017 and Canadian RSS-247, Issue 2 standard.

1.1. Tests measurement overview according to US CFR Title 47, Subpart 15C and RSS-247, Issue 2

Test cases	Port	References and Limits			EUT set-up	EUT op. mode	Result
		FCC Standard	RSS Standard	Test limit			
TX-Mode							
99% occupied bandwidth	Antenna terminal (conducted)	2.1049(h)	RSS-Gen, Issue 4 Chapter 6.6	99% Power bandwidth	--	--	Remark 2)
26 dB bandwidth	Antenna terminal (conducted)	§15.303 + §15.407(a)(2)(5)	RSS-Gen, Issue 4 Chapter 6.6	26 dB spectral density bandwidth	--	--	Remark 2)
Duty-Cycle	Antenna terminal (conducted)	KDB789033 + ANSI C63.10:2013	KDB789033 + ANSI C63.10:2013	No Limit Criteria	2	1	pass
Transmitter frequency stability	Antenna terminal (conducted)	§ 2.1055 + §15.407(g)		Operation within designated operational band	--	--	Remark 2)

Maximum output power	Antenna terminal (conducted)	§15.407(a) (1)(iv) 5.15-5.25 GHz Client devices	RSS-247, Issue 2 Chapter 6.2.1.1	Power Limits (if Antenna Gain < 6 dBi) 250 mW	2	1	Pass
		(2) 5.25-5.35 GHz & 5.47-5.725 GHz	6.2.2.1	lesser of 250mW or 11dBm+10logB			
		(3) 5.725-5.85 GHz	6.2.3.1 6.2.4.1	1 W			
Peak Power Spectral density	Antenna terminal (conducted)	§15.407(a) (1)(iv) 5.15-5.25 GHz Client devices	RSS-247, Issue 2 Chapter 6.2.1.1	Power Spectral Density Limits (if Antenna Gain < 6 dBi) 11dBm/MHz	--	--	Remark 2)
		(2) 5.25-5.35 GHz & 5.47-5.725 GHz	6.2.2.1	11dBm/MHz			
		(3) 5.725-5.85 GHz	6.2.3.1 6.2.4.1	30dBm/500kHz			
Maximum e.i.r.p. power	Antenna terminal (conducted) + Antenna Gain	§15.407(a) (1)(iv) 5.15-5.25 GHz Client devices	RSS-247, Issue 2 Chapter 6.2.1.1	e.i.r.p. Limits (if Antenna Gain < 6 dBi) 250 mW + 6 dBi	2	1	Not Tested + Applicants declaration: Antenna Gain 4.62 dBi
		(2) 5.25-5.35 GHz & 5.47-5.725 GHz	6.2.2.1	lesser of 250mW or 11dBm+10logB + 6 dBi			
		(3) 5.725-5.85 GHz	6.2.3.1 6.2.4.1	1 W + 6 dBi			
Antenna gain information	Antenna terminal (conducted)	§15.407(a) (1)(2)(3)	RSS-247, Issue 2 chapter 6.2.1.1 6.2.2.1 6.2.3.1 6.2.4.1	< 6dBi or if Antenna directional Gain > 6dBi reduction of Max. power & power spectral density by the amount in dB that the directional gain of the antenna exceeds 6 dBi	--	--	Applicants declaration: Antenna Gain 4.62 dBi

General field strength emissions within restricted bands + Band-Edge compliance radiated	Enclosure + Interconnecting cables (radiated)	§ 15.407(b)(1)(2)(3)(4)(5)(6)(7)(8) § 15.205 + § 15.209	RSS-Gen., Issue 4 + RSS-247, Issue 2 Chapter 6.2.1.2, 6.2.2.2, 6.2.3.2, + 6.2.4.2 RSS-Gen., Issue 4 + RSS-247, Issue 2 Chapter 6.2.1.2, 6.2.2.2, 6.2.3.2, + 6.2.4.2	5150-5250 MHz 5250-5350 MHz 5470-5725 MHz all emissions outside operating band shall not exceed -27 dBm/MHz e.i.r.p. 5725-5850 MHz Spectrum Mask acc. to (4)(i) Restricted band limits + General field strength limits	1	1	Pass
Transmit power control + Dynamic frequency selection (DFS)	Antenna terminal (conducted)	§ 15.407 (h1)(h2)	RSS-Gen., Issue 4 + RSS-247, Issue 2 Chapter 6.3	Requirements: Masters Active clients Passive clients	--	--	Remark 3)
Discontinuous transmissions + Device security	FIRMWARE	§ 15.407(c) + § 15.407(i)	RSS-247, Issue 2 Chapter 6.4 a + b + c	No transmissions in case of either absence of information to transmit or operational failure + Protection of firmware by unauthorized parties	--	--	Not tested Applicants declaration of implementation
AC-Power Lines Conducted Emissions	AC-Power lines or Battery Charger	§ 15.207(a)	RSS-Gen., Issue 4: Chapter 8.8 Table 3	AC Power line conducted limits	--	--	Remark 1)

Remark 1) : **Not tested in this report as Bluetooth test configuration was operated using fully charged internal battery**

Refer separate report 18-1-0050701T05a

Remark 2): Refer SIMT 1502 (FCC ID: UDV-20170406) Report No. ER/2017/50038, issue date Aug 09,2017

Remark 3): Refer SIMT 1502 (FCC ID: UDV-20170406) Report No. ER/2017/50039, issue date Jun 13,2017

Specific Absorption Rate (SAR) Measurements (separation distance user to RF-radiating element within 20cm)						
Test cases	Port	References & Limits		EUT set-up	EUT op. mode	Result
		FCC Standard	Test Limit			
Specific Absorption Rate (SAR) requirements	Cabinet + Inter-connecting cables (radiated)	§2.1091 §2.1093 + IEEE 1528-2013 + KDB 865664D01v0r04	Specific Absorption Rate (SAR) for Devices Used by the General Public (Uncontrolled Environment) : 1.6 W/Kg as averaged over any 1 g tissue	--	--	Refer test report Test report no.: 18-1-0050701T01a

General remark: results valid with power 12.5 setting, see document JTA6DG Test instructions

Test report 18-1-0050701T04a_C02 dated 2018-09-25 replace test report 18-1-0050701T04a_C01, dated 2018-09-07. The replaced report gets invalid herewith.

1.2. Attestation:

I declare that all measurements were performed by me or under my supervision and that all measurements have been performed and are correct to my best knowledge and belief to Innovation , Science and Economic Development (ISED) Canada standards. All requirements as shown in above table are met in accordance with enumerated standards.

.....
Dipl.-Ing. Niels Jeß
Responsible for test section

.....
B.Sc. Mohamed Ahmed
Responsible for test report

2. Administrative Data

2.1. Identification of the testing laboratory

Company name:	CETECOM GmbH
Address:	Im Teelbruch 116 45219 Essen - Kettwig Germany
Responsible for testing laboratory:	Dipl.-Ing. Niels Jeß

2.2. Test location

2.2.1. Test laboratory "CTC"

Company name:	see chapter 2.1. Identification of the testing laboratory
---------------	---

2.3. Organizational items

Responsible for test report:	B.Sc. Mohamed Ahmed
Responsible for project:	Dipl.-Ing. Ninovic Perez
Receipt of EUT:	2018-01-08
Date(s) of test:	2018-03-12 - 2018-03-20
Date of report:	2018-09-25

Version of template:	13.02

2.4. Applicant's details

Applicant's name:	Datalogic S.r.l.
Address:	Via S. Vitalino, 13 40012, Lippo di Calderara di Reno (BO) ITALY
Contact :	Mr. Francesco Rossi

2.5. Manufacturer's details

Manufacturer's name:	same as Applicant
Address:	same as Applicant

3. Equipment under test (EUT)

3.1. WLAN 5 GHz 802.11a/n Technical Data Of Main EUT as Declared by Applicant

Frequency Channel B.W. (USA bands only)**	U-NII 1: 5150-5250 MHz	<input checked="" type="checkbox"/> Ch 36 40 44 48 <input type="checkbox"/> Ch. 38 46	<input checked="" type="checkbox"/> Bandwidth 20 MHz <input type="checkbox"/> Bandwidth 40 MHz
	U-NII2A: 5250-5350 MHz	<input checked="" type="checkbox"/> Ch 52 56 60 64 <input type="checkbox"/> Ch. 54 62	<input checked="" type="checkbox"/> Bandwidth 20 MHz <input type="checkbox"/> Bandwidth 40 MHz
	U-NII 2C: 5470-5725 MHz	<input checked="" type="checkbox"/> Ch 100 104 108	<input checked="" type="checkbox"/> Bandwidth 20 MHz <input type="checkbox"/> Bandwidth 40 MHz
		<input checked="" type="checkbox"/> Ch 112 116 120	
		<input checked="" type="checkbox"/> Ch 124 128 132	
		<input checked="" type="checkbox"/> Ch 136 140	
	U-NII 3: 5725 -5850 MHz	<input type="checkbox"/> Ch. 102 110 118	<input checked="" type="checkbox"/> Bandwidth 20 MHz <input type="checkbox"/> Bandwidth 40 MHz
		<input type="checkbox"/> Ch 126 134	
		<input checked="" type="checkbox"/> Ch 149 153 157 <input checked="" type="checkbox"/> Ch 161 165 <input type="checkbox"/> Ch 151 159	
	Channels Power Settings	+20 dBm (According to Applicant's Declaration Max. Rated Power Values)	
802.11a – Mode OFDM Modulation Data Rates	<input checked="" type="checkbox"/> BPSK 6 Mbit / 9 Mbit <input checked="" type="checkbox"/> QPSK 12 Mbit / 18 Mbit <input checked="" type="checkbox"/> 16-QAM 24 Mbit / 36 Mbit <input checked="" type="checkbox"/> 64-QAM 48 Mbit / 54 Mbit		
802.11n – Mode OFDM Modulation Data Rates	<input checked="" type="checkbox"/> HT20 (MCS0 – MCS7) 7.2/14.4/21.7/28.9/43.3/57.8/65/72.2 Mbit <input type="checkbox"/> HT40 (MCS0 – MCS7) 15/30/45/60/90/120/135/150 Mbit		
Antenna Details	Integrated (ANT1 & ANT2)		
Antenna Connections	Primary Antenna: ANT1(WLAN 5 GHz) Secondary Antenna: ANT2 not used		
ANT1 Gain (Peak)	4.62 dBi (4900 MHz – 5900 MHz) (According to Applicant's Declaration)		
ANT2 Gain (Peak)	2.14 dBi (2400 MHz – 2482,5 MHz) (According to Applicant's Declaration)		

Total Number of Modules	1		
Total Number of Antennas	2	Primary ANT1 : WLAN 5 GHz	Secondary ANT2: not used
Test Mode Settings	Datalogic WiFi Test Application		
MAX Field Strength (Radiated @ 3m)	U-NII 1: 5150-5250 MHz	102.998 dBµV/m (PK)	93.098 dBµV/m (AV)
	U-NII2A: 5250-5350 MHz	104 dBµV/m (PK)	93.521 dBµV/m (AV)
	U-NII 2C: 5470-5725 MHz	102.806 dBµV/m (PK)	92.872 dBµV/m (AV)
	U-NII 3: 5725-5850 MHz	95.754 dBµV/m (PK)	85.051 dBµV/m (AV)
Power Supply	<input checked="" type="checkbox"/> Internal Battery: Li-ion 3.75- 4.35VDC 3030mAh		
Special EMI Components	--		
EUT Sample Type	<input type="checkbox"/> Production	<input checked="" type="checkbox"/> Pre-Production	<input type="checkbox"/> Engineering
Firmware	<input type="checkbox"/> for normal use	<input checked="" type="checkbox"/> Special version for test execution : Datalogic WiFi Test	
FCC label attached	<input type="checkbox"/> Yes	<input checked="" type="checkbox"/> No	

For further details refer Applicants Declaration & following technical documents

Description of Reference Document (supplied by applicant)	Version	Total Pages
Operational Description_JOYA TOUCH A6	Rev: 02 Date: 11-May-2018	9
JTA6_FCC_Safety_&_Regulatory_addendum	Rev: A Date: April-2018	15
JTA: Test Instructions	Rev: 01 Date: 17-May-2018	18

** Until further notice, devices subject to RSS-247, Issue 2, February 2017 section 6.2.3

Operating in Frequency bands 5470-5600 MHz and 5650-5725 MHz shall not transmit in the band 5600-5650 MHz.

This restriction is for the protection of Environment Canada's weather radars operating in this band.

3.2. EUT: Type, S/N etc. and short descriptions used in this test report

Short Description*)	EUT	Type	Serial Number	Hardware Status	Software Status
EUT A	Joya Touch A6 (Gun Variant)	A00AN04HLXGT0A N	G18D03796	BETA	02.12
EUT B	Joya Touch A6 (Gun Variant conducted)	A00AN04HLXGT0AN	G18D03791	BETA	02.12
EUT C	Joya Touch A6 (Handheld Variant)	A00AN04HLXHT0AN	G18D03794	BETA	02.12

*) EUT short description is used to simplify the identification of the EUT in this test report.

3.3. Auxiliary Equipment (AE): Type, S/N etc. and short descriptions

AE short description *)	Auxiliary Equipment	Type	S/N serial number	HW hardware status	SW software status
AE 1	--	--	--	--	--

*) AE short description is used to simplify the identification of the auxiliary equipment in this test report.

3.4. EUT set-ups

EUT set-up no. *)	Combination of EUT and AE	Description
set. 1	EUT A	Used for radiated tests
set. 2	EUT B	Used for conducted tests
set. 3	EUT C	Used for radiated tests

*) EUT set-up no. is used to simplify the identification of the EUT set-up in this test report.

3.5. EUT operating modes

EUT operating mode no. *1)	Description of operating modes	Additional information
op. 1	TX-Mode	With help of special test Software (CTA-WIFI Test Tool, Version: 1.0.0) a continuous traffic mode in duty cycle was set-up *2)

*1) EUT operating mode no. is used to simplify the test report.

*2)) Please refer to document “20180613_FCC_JTA_Test-Tools_Quick_Start_Instructions” dated 2018-06-13 for additional information regarding operating mode setup and output power levels.

The Test Software CTA-WIFI Test Tool was implemented on the EUT

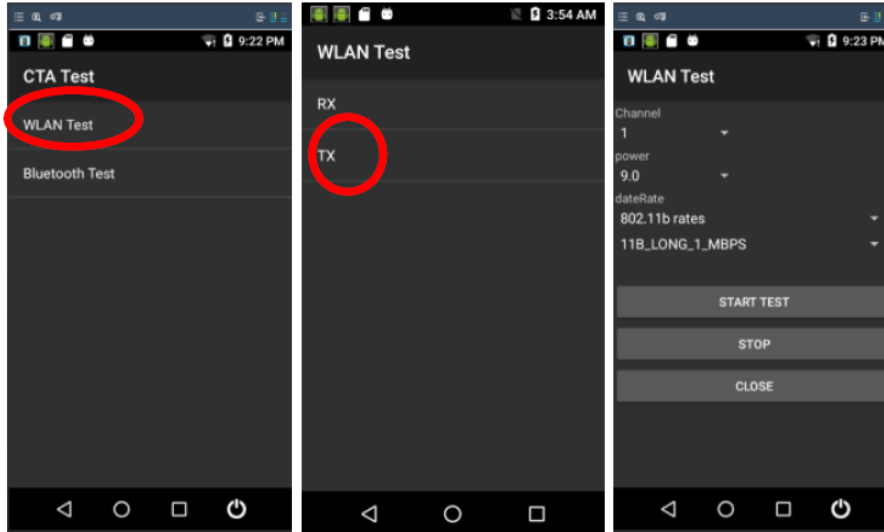

Wifi Settings for each mode and Channel:

5 GHz	802.11a	54Mbps	802.11 a/g rates	11A_54_MBPS	11
		48Mbps	802.11 a/g rates	11A_48_MBPS	12
		36Mbps	802.11 a/g rates	11A_36_MBPS	12.5
		24Mbps	802.11 a/g rates	11A_24_MBPS	12.5
		18Mbps	802.11 a/g rates	11A_18_MBPS	12.5
		12Mbps	802.11 a/g rates	11A_12_MBPS	12.5
		9Mbps	802.11 a/g rates	11A_9_MBPS	12.5
		6Mbps	802.11 a/g rates	11A_6_MBPS	12.5
	802.11n	MCS7-HT20	MCS (20MHz)	MCS_72_2_MBPS	9
		MCS6-HT20	MCS (20MHz)	MCS_58_5_MBPS	10.5
		MCS5-HT20	MCS (20MHz)	MCS_52_MBPS	12
		MCS4-HT20	MCS (20MHz)	MCS_39_MBPS	12.5
		MCS3-HT20	MCS (20MHz)	MCS_26_MBPS	12.5
		MCS2-HT20	MCS (20MHz)	MCS_19_5_MBPS	12.5
		MCS1-HT20	MCS (20MHz)	MCS_13_MBPS	12.5
MCS0-HT20	MCS (20MHz)	MCS_6_5_MBPS	12.5		

4. Description of test system set-up's

4.1. Test system set-up for conducted measurements on antenna port

Conducted Set-up W1

Conducted RF-Setup 1 (W1 Set-up)

General description:

The EUT's RF-signal is coupled out by a suitable antenna coupling connector (1). The signal is first attenuated (2) then connected to the power meter (3) for conducted power measurements. The specific attenuation loss is determined prior to the measurement within a set-up attenuation measurement. These are then taken into account by correcting the measurement readings.

Schematic:

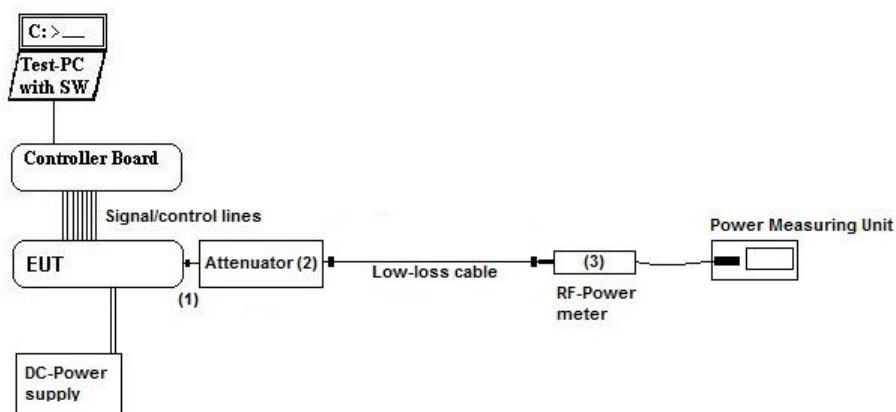

Testing method:

ANSI C63.10:2013,
KDB 789033 D02 General UNII Test Procedures New Rules v01r03

Used Equipment

Passive Elements	Test Equipment	Remark:
<input checked="" type="checkbox"/> 20 dB Attenuator	<input checked="" type="checkbox"/> Power Meter	See List of equipment under each test case and chapter 6 for calibration info
<input checked="" type="checkbox"/> Low loss RF-cables	<input checked="" type="checkbox"/> DC-Power Supply	
<input checked="" type="checkbox"/>	<input checked="" type="checkbox"/> Spectrum-Analyser	

Measurement uncertainty

See chapter 5.7

Conducted Set-up W2

Conducted RF-Setup 2 (W2 Set-up)

General description: The EUT's RF-signal is coupled out by a suitable antenna coupling connector (1). The signal is first attenuated (2) then connected to spectrum-analyzer (4) for RF-conducted measurements. The specific attenuation loss is determined prior to the measurement within a set-up attenuation measurement. These are then taken into account by correcting the measurement readings of the spectrum-analyzer.

Schematic:

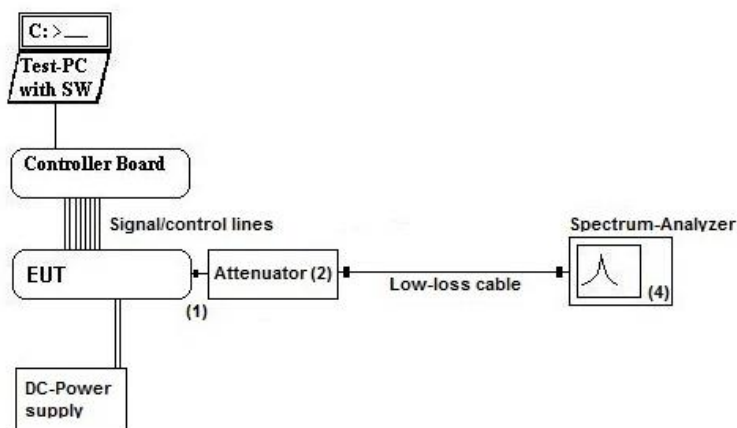

Testing method: ANSI C63.10:2013,
KDB 789033 D02 General UNII Test Procedures New Rules v01r03

Used Equipment	Passive Elements	Test Equipment	Remark:
	<input checked="" type="checkbox"/> 20 dB Attenuator	<input checked="" type="checkbox"/> Power Meter	See List of equipment under each test case and chapter 6 for calibration info
	<input checked="" type="checkbox"/> Low loss RF-cables	<input checked="" type="checkbox"/> DC-Power Supply	
		<input checked="" type="checkbox"/> Spectrum-Analyser	

Measurement uncertainty See chapter 5.7

4.2. Test system set-up for radiated magnetic field measurements below 30 MHz

Specification: ANSI C63.4-2014 §5.3, §8.2.1, §8.3.1.1+§8.3.2.1 , ANSI C63.10-2013 chapter 6.4 (§6.4.4.2)

General Description: Evaluating the radiated field emissions are done first by an exploratory emission measurement and a final measurement for most critical frequencies determined.

The loop antenna was placed at 1 m height above ground plane and 3 m measurement distance from set-up for investigations. Because of reduced measurement distance, correction data were applied, as stated in chapter “General Limit - Radiated field strength emissions below 30 MHz“. The tests are performed in the semi anechoic room recognized by the regulatory commission.

Schematic:

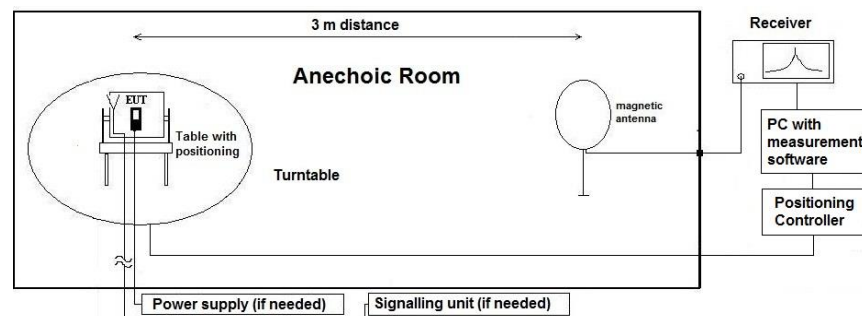

Testing method:

Exploratory, preliminary measurement

The EUT and its associated accessories are placed on a non-conductive position manipulator (tipping device) of 0.8 m height which is placed on the turntable. By rotating the turntable (step 90°, range 0° to 360°) and the EUT itself either on 3-orthogonal axis (portable equipment) or 2-orthogonal axis (defined operational position of EUT), the emission spectrum was recorded. The loop antenna was moved at least to 2-perpendicular axes (antenna vector in direction of EUT and parallel to EUT) in order to maximize the emissions. The results are documented in a diagram. Critical frequencies (low margin to limit) are saved within a data reduction table for further investigations. If various operating modes are supported, further investigations are made to find the worst-case. Also the interconnection cables and equipment position were varied in order to maximize the emissions.

Final measurement on critical frequencies

Based on the exploratory measurements, the most critical frequencies are re-measured by maintaining the EUT's worst-case operation mode, cable position, etc.

First a frequency zoom around the critical frequency is done to locate the frequency more precisely. After this step, for all identified critical frequencies, the maximum peak was determined.

Following parameters were varied: the turntable angle continuously in the range 0 to 360 degree, the EUT itself either over 3-orthogonal axis (not defined usage position) or 2-orthogonal axis (defined usage position).

On the determined worst-case position, a final measurement with necessary bandwidth and detector according standard has been carried out.

Formula:

$$E_C = E_R + AF + C_L + D_F - G_A$$

$$M = L_T - E_C$$

AF = Antenna factor

C_L = Cable loss

D_F = Distance correction factor

E_C = Electrical field – corrected value

E_R = Receiver reading

G_A = Gain of pre-amplifier (if used)

L_T = Limit

M = Margin

All units are dB-units, positive margin means value is below limit.

Distance correction:

Reference for applied correction (extrapolating) factors due to reduced measurement distance:

ANSI C63.10:2013, §6.4.4.2 - Equations (2) + (3) + (4)

4.3. Test system set-up for radiated electric field measurement 30 MHz to 1 GHz

Specification: ANSI C63.4-2014 chapter 8.2.3, ANSI C63.10-2013 chapter 6.5

General Description: Evaluating the field emissions have to be done first by an exploratory emissions measurement and a final measurement for most critical frequencies. The tests are performed in a NSA-compliant semi anechoic room (SAR) recognized by the regulatory commissions.

Schematic:

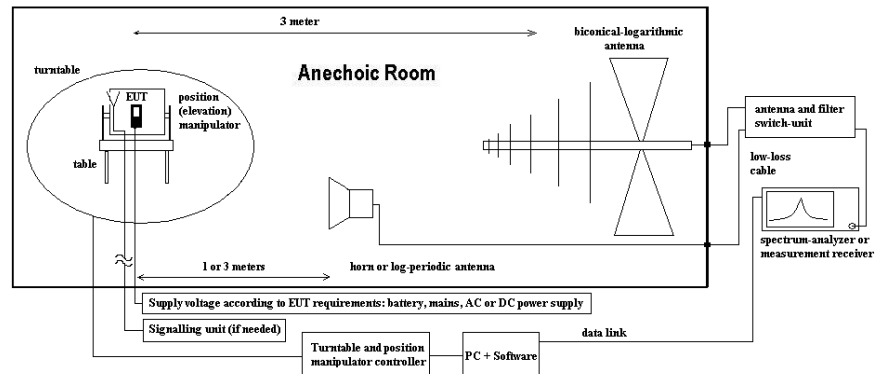

Testing method:

Exploratory, preliminary measurements

The EUT and its associated accessories are placed on a non-conductive position manipulator (tipping device) of 0.8 m height which is placed on the turntable. By rotating the turntable (range 0° to 360°, step 90°) and the EUT itself either on 3-orthogonal axis (portable equipment) or 2-orthogonal axis (defined operational position of EUT) the emission spectrum and its characteristics was recorded with an EMI-receiver, broadband antenna and software.

Measurement antenna: horizontal and vertical, heights: 1,0 m and 1,82 m as worst-case determined by an exploratory emission measurements. The results are documented in a diagram. Critical frequencies (low margin to limit) are saved within a table for further investigations. If various operating modes are supported, further investigations are made to find the worst-case of them. Also the interconnection cables and equipment position were varied in order to maximize the emissions.

Final measurement on critical frequencies

Based on the exploratory measurements, the most critical frequencies are re-measured by maintaining the EUT's worst-case operation mode, cable position, etc. either on 10m OATS or 3m semi-anechoic room.

First a frequency zoom around the critical frequency is done to locate the frequency more precisely. After this step, for all identified critical frequencies, the maximum peak was determined.

Following parameters were varied: the turntable angle continuously in the range 0 to 360 degree, the EUT itself either over 3-orthogonal axis (not defined usage position) or 2-orthogonal axis (defined usage position). The measurement antenna height between 1 m and 4 m.

On the determined worst-case position, a final measurement with necessary bandwidth and detector according standard has been carried out.

Formula:

$$E_C = E_R + AF + C_L + D_F - G_A \quad (1)$$

$$M = L_T - E_C \quad (2)$$

- AF = Antenna factor
- C_L = Cable loss
- D_F = Distance correction factor (if used)
- E_C = Electrical field – corrected value
- E_R = Receiver reading
- G_A = Gain of pre-amplifier (if used)
- L_T = Limit
- M = Margin

All units are dB-units, positive margin means value is below limit.

4.4. Test system set-up for radiated electric field measurement above 1 GHz

Specification: ANSI C63.4-2014 chapter 8.3, ANSI C63.10-2013 chapter 6.6.3.3 & 6.6.4

General Description: Evaluating the emissions have to be done first by an exploratory emissions measurement and a final measurement for most critical frequencies. The tests are performed in a CISPR 16-1-4:2010 compliant fully anechoic room (FAR) recognized by the regulatory commission. The measurement distance was set to 3 meter for frequencies up to 18 GHz and 2 meter above 18 GHz. A logarithmic periodic antenna is used for the frequency range 30 MHz to 1 GHz. Horn antennas are used for frequency range 1 GHz to 40 GHz. The EUT is aligned within 3 dB beam width of the measurement antenna with three orthogonal axis measurements on the EUT.

Schematic:

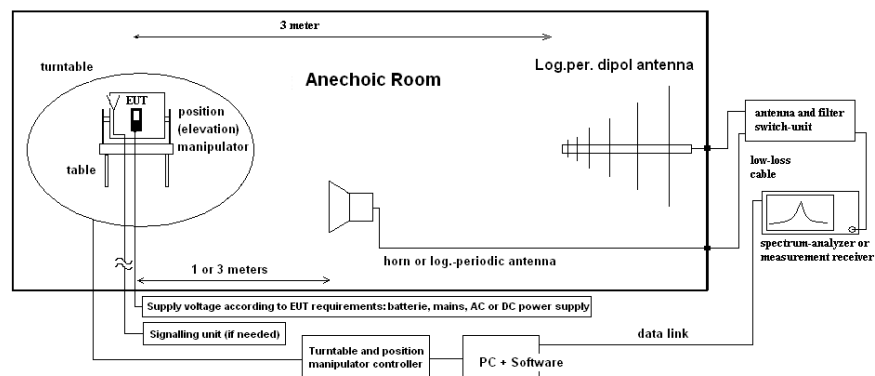

Testing method:

Exploratory, preliminary measurements

The EUT and its associated accessories are placed on a non-conductive position manipulator (tipping device) of 1.55 m height which is placed on the turntable. By rotating the turntable (range 0° to 360°, step 15°) and the EUT itself either on 3-orthogonal axis (portable equipment) or 2-orthogonal axis (defined operational position of EUT) the emission spectrum and its characteristics was recorded with an EMI-receiver, broadband antenna and software. The measurements are performed in horizontal and vertical polarization of the measurement antennas. The results are documented in a diagram. Critical frequencies (low margin to limit) are saved within a table for further investigations. If various operating modes are supported, further investigations are made to find the worst-case of them. Also the interconnection cables and equipment position were varied in order to maximize the emissions.

Final measurement on critical frequencies

Based on the exploratory measurements, the most critical frequencies are re-measured by maintaining the EUT's worst-case operation mode, cable position, etc.

First a frequency zoom around the critical frequency is done to locate the frequency more precisely. After this step, for all identified critical frequencies, the maximum peak was determined. Following parameters were varied: the turntable angle continuously in the range 0 to 360 degree, the EUT itself over 3-orthogonal axis and the height for EUT with large dimensions.

On the determined worst-case position, a final measurement with necessary bandwidth and detector according standard has been carried out. On the determined worst-case position, a final measurement with necessary bandwidth and detector according standard has been carried out.

Formula:

$$E_C = E_R + AF + C_L + D_F - G_A \quad (1)$$

$$M = L_T - E_C \quad (2)$$

E_C = Electrical field – corrected value

E_R = Receiver reading

M = Margin

L_T = Limit

AF = Antenna factor

C_L = Cable loss

D_F = Distance correction factor (if used)

G_A = Gain of pre-amplifier (if used)

All units are dB-units, positive margin means value is below limit.

5. Measurements

5.1. Duty-Cycle

5.1.1. Test location and equipment (for reference numbers please see chapter 'List of test equipment')

Ambient Climatic conditions			Temperature: (22±2)°C			Rel. humidity: (45±15)%		
Test Site	<input type="checkbox"/> 441 EMI SAR	<input type="checkbox"/> 348 EMI cond.	<input type="checkbox"/> 443 EMI FAR	<input checked="" type="checkbox"/> 347 Radio.lab.	<input type="checkbox"/> 337 OATS	<input type="checkbox"/>	<input type="checkbox"/>	<input type="checkbox"/>
Equipment	<input type="checkbox"/> 331 HC 4055	<input type="checkbox"/>	<input type="checkbox"/>	<input checked="" type="checkbox"/> 693 TS8997	<input type="checkbox"/>	<input type="checkbox"/>	<input type="checkbox"/>	<input type="checkbox"/>
Spectr. Analys.	<input checked="" type="checkbox"/> 683 FSU26	<input type="checkbox"/> 120 FSEM	<input type="checkbox"/> 264 FSEK	<input checked="" type="checkbox"/> 693 TS8997	<input type="checkbox"/>	<input type="checkbox"/>	<input type="checkbox"/>	<input type="checkbox"/>
Power Meter	<input type="checkbox"/> 262 NRV-S	<input type="checkbox"/> 266 NRV-Z31	<input type="checkbox"/> 265 NRV-Z33	<input type="checkbox"/> 261 NRV-Z55	<input type="checkbox"/> 356 NRV-Z1	<input type="checkbox"/>	<input type="checkbox"/>	<input type="checkbox"/>
Multimeter	<input type="checkbox"/> 341 Fluke 112	<input type="checkbox"/>	<input type="checkbox"/>	<input type="checkbox"/>	<input type="checkbox"/>	<input type="checkbox"/>	<input type="checkbox"/>	<input type="checkbox"/>
DC Power	<input type="checkbox"/> 086 LNG50-10	<input type="checkbox"/> 087 EA3013	<input type="checkbox"/> 354 NGPE 40	<input type="checkbox"/> 349 car battery	<input type="checkbox"/> 350 Car battery	<input type="checkbox"/>	<input type="checkbox"/>	<input type="checkbox"/> 463 HP3245A
Supply Voltage	<input type="checkbox"/> 230 V 50 Hz via public mains			<input checked="" type="checkbox"/> 3.77 V DC (fully charged internal battery)				
Otherwise	<input checked="" type="checkbox"/> 530 Attenuator 10dB	<input checked="" type="checkbox"/> K4 Cable						

Method of measurement: conducted
 radiated

A special firmware program is used for test purposes. In contrast to normal operating mode a higher duty-cycle is set in order to facilitate the measurements. This is maximized at the extent possible.

The necessary duty-cycle correction factor is determined on nominal conditions on 1 channel for all sub-bands. It is assumed that no noticeable changes occur when tested on other channels or climatic conditions.

Calculated with following formulas:

Duty cycle:	$x = \frac{T_{x_{on}}}{T_{x_{on}} + T_{x_{off}}}$	Duty cycle factor [dB]:	$10 \log \left(\frac{1}{x} \right)$
-------------	---	-------------------------	--------------------------------------

DUTY-CYCLE Measurement								
WLAN 5 GHz	Marker 1	Marker 2	Marker 3	TX ON Marker 2 - Marker 1	TX OFF Marker 3 - Marker 2	Duty Cycle	Correction- Factor: 100log(1/DC)	Plot No.
Data Rate	ms	ms	ms	ms	ms	(%)	(dB)	(Remark 1)
WLAN 5 GHz a-Mode Ch 36 (5180 MHz)								
6MBit	0,496440	1,856090	2,054107	1,359650	0,19802	87,29	0,59	1
18MBit	0,050641	0,516824	0,717051	0,466183	0,20023	69,95	1,55	1
54MBit	0,166026	0,336536	0,536763	0,170510	0,20023	45,99	3,37	2
WLAN 5 GHz n(HT20)-Mode Ch 36 (5180 MHz)								
MCS0	1,306821	2,443859	2,629782	1,13704	0,18592	85,95%	0,66	3
MCS4	0,288622	0,530642	0,731474	0,24202	0,20083	54,65%	2,62	4
MCS7	0,607141	0,767869	0,966506	0,16073	0,19864	44,73%	3,49	4

For power averaging (RMS) factor 10*log10(1/x) was used

- The results were corrected in order to evaluate for worst-case result each time when average values are necessary for example average radiated emissions or similar
- No correction necessary: Duty-Cycle > 98%

5.2. RF-Parameter - Transmitter Peak output power (conducted and radiated)

5.2.1. Test location and equipment (for reference numbers please see chapter 'List of test equipment')

test location	<input checked="" type="checkbox"/> CETECOM Essen (Chapter. 2.2.1)	<input type="checkbox"/> 443 System CTC-FAR-EMI-	<input type="checkbox"/> Please see Chapter. 2.2.3
test site	<input type="checkbox"/> 441 EMI SAR	<input type="checkbox"/> 487 SAR NSA	<input type="checkbox"/> 337 OATS
receiver	<input type="checkbox"/> 377 ESCS30	<input type="checkbox"/> 001 ESS	<input type="checkbox"/> 489 ESU 40
otherwise	<input checked="" type="checkbox"/> 600 NRVD	<input checked="" type="checkbox"/> 357 NRV-Z1	<input checked="" type="checkbox"/> 693 TS8997
spectr. analys.	<input type="checkbox"/> 215 FSU	<input type="checkbox"/> 120 FSEM	<input type="checkbox"/> 264 FSEK
power supply	<input type="checkbox"/> 456 EA 3013A	<input type="checkbox"/> 457 EA 3013A	<input type="checkbox"/> 459 EA 2032-50
otherwise	<input checked="" type="checkbox"/> 613 20 dB Attenuator	<input type="checkbox"/> 248 6 dB Attenuator	<input type="checkbox"/> 529 Power divider
Supply voltage	<input type="checkbox"/> 230 V 50 Hz via public mains		<input checked="" type="checkbox"/> 3.77 V DC (fully charged internal battery)

5.2.2. Reference:

FCC	<input checked="" type="checkbox"/> Part 15 Subpart C, §15.407(a)(1)(2)(3)(4)
ISED	<input checked="" type="checkbox"/> RSS-247, Issue 2
ANSI	<input checked="" type="checkbox"/> C63.10-2013
KDB Guidance no.	<input checked="" type="checkbox"/> KDB 789033 D02 General UNII Test Procedures New Rules v01r03: Subchapter E, <u>Method PM (3)(a)</u> <input type="checkbox"/> KDB 662911 D01 Multiple Transmitter Output v02r01 (MIMO, Smart-antenna)
Limits	<input checked="" type="checkbox"/> U-NII 1: 5.15-5.25 GHz: FCC Outdoor access point: 1W + antenna gain max. 6dBi + Elevation > 30° 21 dBm EIRP FCC Indoor Access Point: 1W + antenna gain max. 6dBi FCC Mobile & Portable client: 250mW + antenna gain max. 6dBi ISED: <input checked="" type="checkbox"/> E.I.R.P. max. 200mW or 10+10log ₁₀ (B) whichever power is less <input type="checkbox"/> OEM device installed on vehicles: 30mW EIRP or 1.76 + 10log ₁₀ (B) + TPC capability
	<input checked="" type="checkbox"/> U-NII2: 5.25-5.35 GHz: FCC: lesser of 250mW or 11dBm+10log ₁₀ (B) ISED: <input checked="" type="checkbox"/> max. conducted output power: 250mW or 11dBm+10log ₁₀ (B) + Antenna gain < 6dBi <input type="checkbox"/> EIRP Elevation Mask requirements if max. EIRP>200mW <input type="checkbox"/> Max. EIRP 1Watt or 17+10log ₁₀ (B) whichever power less <input type="checkbox"/> OEM device installed on vehicles: 30mW EIRP or 1.76 + 10log ₁₀ (B) + TPC capability
	<input checked="" type="checkbox"/> U-NII2extension: 5.470-5.725 GHz: FCC: lesser of 250mW or 11dBm+10log ₁₀ (B) + Antenna gain < 6dBi ISED: <input checked="" type="checkbox"/> Lesser of: lesser of 250mW or 11dBm+10log ₁₀ (B) <input checked="" type="checkbox"/> Max. EIRP 1Watt or 17+10log ₁₀ (B) whichever power less <input type="checkbox"/> TPC required if MAX. EIRP > 500mW
	<input checked="" type="checkbox"/> U-NII3: 5.725-5.850 GHz: FCC/ISED: <input checked="" type="checkbox"/> max. conducted power: 1 Watt (30dBm) <input checked="" type="checkbox"/> Antenna gain less 6dBi <input type="checkbox"/> Antenna gain more 6dBi (-> reduction necessary)

5.2.3. Antenna characteristics:

- directional gain < 6 dBi (Applicants declaration)
 directional gain > 6 dBi (measured / applicant's declaration) -> conducted power reduction necessary

5.2.4. EUT settings:

The EUT was instructed to send with maximum power (if adjustable) according applicants instructions.

5.2.5. Measurement method:

Method used	Reference to KDB	Remarks:
<input type="checkbox"/> SA	KDB 789033 D02 General UNII Test Procedures New Rules v01r03	Integration bandwidth method
<input checked="" type="checkbox"/> Power Meter	a.) Method PM	A wideband thermocouple RF-power meter as described by KDB was used. <input checked="" type="checkbox"/> Duty-Cycle correction necessary <input type="checkbox"/> A value correction is not necessary since the EUT is transmitting continuously at duty-cycle > 98%.

5.2.6. Conducted power measurement and EIRP calculations

- Applicant’s declared Maximum Directional Antenna Peak Gain : 4.62 dBi at 5 GHz Band Range

5.2.7. Results for a-Mode:

FCC15.407 Limits & Verdict				
Operational Bands:	U-NII 1 (Conducted + EIRP limit)	U-NII-2A (conducted + EIRP limit)	U-NII 2C (conducted + EIRP limit)	U-NII 3 (conducted + EIRP)
Highest Conducted Value Subband [dBm]	12,41	12,17	10,35	11,88
Duty-Cycle correction [dB]	1,55	1,55	1,55	1,55
Conducted value including DC-correction	13,96	13,72	11,90	13,43
Conducted Limits or EIRP [dBm]	23,97	23,36	23,36	30,00
Conducted value - margin to Limit [dB]	11,56	11,19	13,02	18,12
Conducted Verdict PASS / FAIL ?	PASS	PASS	PASS	PASS
Antenna Gain [dBi]	4,62	4,62	4,62	4,62
Highest E.I.R.P. Value Subband [dBm]	18,58	18,34	16,52	18,05
E.I.R.P. Limits [dBm]	29,98	29,36	29,36	36,00
Margin to E.I.R.P. Limits [dB]	11,40	11,02	12,85	17,95
E.I.R.P. Verdict PASS / FAIL ?	PASS	PASS	PASS	PASS

RSS-247, Issue 2, Limits & Verdict				
Operational Bands:	U-NII 1 (EIRP limit)	U-NII-2A (conducted + EIRP limit)	U-NII 2C (conducted + EIRP limit)	U-NII 3 (conducted + EIRP)
Highest Conducted Value Subband [dBm]	12,41	12,17	10,35	11,88
Duty-Cycle correction [dB]	1,55	1,55	1,55	1,55
Conducted value including DC-correction [dB]	13,96	13,72	11,90	13,43
Conducted Limits or EIRP [dBm]	--	23,36	23,36	30,00
Conducted value - margin to Limit [dB]	--	11,19	13,02	18,12
Conducted Verdict PASS / FAIL ?	--	PASS	PASS	PASS
Antenna Gain [dBi]	4,62	4,62	4,62	4,62
Highest E.I.R.P. Value Subband [dBm]	18,58	18,34	16,52	18,05
E.I.R.P. Limits [dBm]	22,36	29,36	29,36	36,00
Margin to E.I.R.P. Limits [dB]	3,78	11,02	12,85	17,95
E.I.R.P. Verdict PASS / FAIL ?	PASS	PASS	PASS	PASS

5.2.8. Results for n-Mode:

FCC15.407 Limits & Verdict				
Operational Bands:	U-NII 1 (Conducted + EIRP limit)	U-NII-2A (conducted + EIRP limit)	U-NII 2C (conducted + EIRP limit)	U-NII 3 (conducted + EIRP)
Highest Conducted Value Subband [dBm]	12,37	12,21	10,23	12,00
Duty-Cycle correction [dB]	2,62	0,66	2,62	2,62
Conducted value including DC-correction [dB]	14,99	12,87	12,85	14,62
Conducted Limits or EIRP [dBm]	23,97	23,55	23,55	30,00
Conducted value - margin to Limit [dB]	11,61	11,34	13,32	18,00
Conducted Verdict PASS / FAIL ?	PASS	PASS	PASS	PASS
Antenna Gain[dBi]	4,62	4,62	4,62	4,62
Highest E.I.R.P. Value	19,61	17,49	17,47	19,24
E.I.R.P. Limits[dBm]	29,98	29,55	29,36	36,00
Margin to E.I.R.P. Limits [dB]	10,38	12,06	11,89	16,76
E.I.R.P. Verdict PASS / FAIL ?	PASS	PASS	PASS	PASS

RSS-247, Issue 2, Limits & Verdict				
Operational Bands:	U-NII 1 (EIRP limit)	U-NII-2A (conducted + EIRP limit)	U-NII 2C (conducted + EIRP limit)	U-NII 3 (conducted + EIRP)
Highest Conducted Value Subband [dBm]	12,37	12,21	10,23	12,00
Duty-Cycle correction [dB]	2,62	0,66	2,62	2,62
Conducted value including DC-correction [dB]	14,99	12,87	12,85	14,62
Conducted Limits or EIRP [dBm]	--	23,55	23,36	30,00
Conducted value - margin to Limit [dB]	--	11,34	13,13	18,00
Conducted Verdict PASS / FAIL ?	--	PASS	PASS	PASS
Antenna Gain[dBi]	4,62	4,62	4,62	4,62
Highest E.I.R.P. Value Subband [dBm]	19,61	17,49	17,47	19,24
E.I.R.P. Limits[dBm]	22,55	29,55	29,36	36,00
Margin to E.I.R.P. Limits [dB]	2,95	12,06	11,89	16,76
E.I.R.P. Verdict PASS / FAIL ?	PASS	PASS	PASS	PASS

5.2.9. Verdict: Pass

5.3. General Limit - Radiated field strength emissions below 30 MHz

5.3.1. Test location and equipment

test location	<input checked="" type="checkbox"/> CETECOM Essen (Chapter. 2.2.1)	<input type="checkbox"/> Please see Chapter. 2.2.2	<input type="checkbox"/> Please see Chapter. 2.2.3
test site	<input checked="" type="checkbox"/> 441 EMI SAR	<input type="checkbox"/> 487 SAR NSA	<input type="checkbox"/> 347 Radio.lab.
receiver	<input type="checkbox"/> 377 ESCS30	<input checked="" type="checkbox"/> 001 ESS	<input type="checkbox"/>
spectr. analys.	<input type="checkbox"/> 584 FSU	<input type="checkbox"/> 120 FSEM	<input type="checkbox"/> 264 FSEK
antenna	<input type="checkbox"/> 574 BTA-L	<input type="checkbox"/> 133 EMCO3115	<input type="checkbox"/> 302 BBHA9170
signaling	<input type="checkbox"/> 392 MT8820A	<input type="checkbox"/> 371 CBT32	<input type="checkbox"/> 547 CMU
otherwise	<input type="checkbox"/> 400 FTC40x15E	<input type="checkbox"/> 401 FTC40x15E	<input type="checkbox"/> 110 USB LWL
DC power	<input type="checkbox"/> 671 EA-3013S	<input type="checkbox"/> 457 EA 3013A	<input type="checkbox"/> 459 EA 2032-50
Supply voltage	<input type="checkbox"/> 230 V 50 Hz via public mains	<input checked="" type="checkbox"/> 3.77 V DC (fully charged internal battery)	

5.3.2. Requirements

FCC	Part 15, Subpart C, §15.205 & §15.209			
ISED	RSS-Gen: Issue 5: §8.9 Table 6			
ANSI	C63.10-2013			
Frequency [MHz]	Field strength limit		Distance [m]	Remarks
	[μ V/m]	[dB μ V/m]		
0.009 – 0.490	2400/f (kHz)	67.6 – 20Log(f) (kHz)	300	Correction factor used due to measurement distance of 3 m
0.490 – 1.705	24000/f (kHz)	87.6 – 20Log(f) (kHz)	30	Correction factor used due to measurement distance of 3 m
1.705 – 30	30	29.5	30	Correction factor used due to measurement distance of 3 m

5.3.3. Test condition and test set-up

Signal link to test system (if used):		<input type="checkbox"/> air link	<input type="checkbox"/> cable connection	<input checked="" type="checkbox"/> none
EUT-grounding		<input checked="" type="checkbox"/> none	<input type="checkbox"/> with power supply	<input type="checkbox"/> additional connection
Equipment set up		<input checked="" type="checkbox"/> table top		<input type="checkbox"/> floor standing
Climatic conditions		Temperature: (22 \pm 3 $^{\circ}$ C)		Rel. humidity: (40 \pm 20)%
EMI-Receiver or Analyzer Settings	Scan data	<input checked="" type="checkbox"/> 9 – 150 kHz RBW/VBW = 200 Hz Scan step = 80 Hz <input checked="" type="checkbox"/> 150 kHz – 30 MHz RBW/VBW = 9 kHz Scan step = 4 kHz <input type="checkbox"/> other:		
	Scan-Mode	<input checked="" type="checkbox"/> 6 dB EMI-Receiver Mode <input type="checkbox"/> 3dB Spectrum analyser Mode		
	Detector	Peak (pre-measurement) and Quasi-PK/Average (final if applicable)		
Mode:	Repetitive-Scan, max-hold			
Sweep-Time	Coupled – calibrated display if continuous signal otherwise adapted to EUT's individual transmission duty-cycle			
General measurement procedures		Please see chapter "Test system set-up radiated magnetic field measurements below 30 MHz"		

5.3.4. Radiated Field Strength Emissions – 9 kHz to 30 MHz Results

Table of measurement results:

Diagram No.	Carrier Channel		Frequency range of measurement	Set-up no.	OP-mode no.	Remark	Used detector			Result
	Range [MHz]	Channel					PK	AV	QP	
2.01a	5150-5250	36	9 kHz-30 MHz	1 + 3	1	EUT standing position	<input checked="" type="checkbox"/>	<input type="checkbox"/>	<input type="checkbox"/>	passed
2.01b		36				EUT laying position	<input checked="" type="checkbox"/>	<input type="checkbox"/>	<input type="checkbox"/>	passed
2.02a		48	9 kHz-30 MHz	1	1	EUT standing position	<input checked="" type="checkbox"/>	<input type="checkbox"/>	<input type="checkbox"/>	passed
2.03a	5250-5350	52	9 kHz-30 MHz	1	1	EUT standing position	<input checked="" type="checkbox"/>	<input type="checkbox"/>	<input type="checkbox"/>	passed
2.04a		64	9 kHz-30 MHz	1	1	EUT standing position	<input checked="" type="checkbox"/>	<input type="checkbox"/>	<input type="checkbox"/>	passed
2.05a	5470-5700	100	9 kHz-30 MHz	1	1	EUT standing position	<input checked="" type="checkbox"/>	<input type="checkbox"/>	<input type="checkbox"/>	passed
--		120-128	9 kHz-30 MHz	--	--	Not usable in Canada	<input type="checkbox"/>	<input type="checkbox"/>	<input type="checkbox"/>	remark
2.06a		140	9 kHz-30 MHz	1	1	EUT standing position	<input checked="" type="checkbox"/>	<input type="checkbox"/>	<input type="checkbox"/>	passed
2.07a	5725-5850	149	9 kHz-30 MHz	1	1	EUT standing position	<input checked="" type="checkbox"/>	<input type="checkbox"/>	<input type="checkbox"/>	passed
2.08a		165	9 kHz-30 MHz	1	1	EUT standing position	<input checked="" type="checkbox"/>	<input type="checkbox"/>	<input type="checkbox"/>	passed

Remark: no channel shall be used between 5600-5650MHz in Canada according RSS-247, Issue 2 regulations

5.3.5. Correction factors due to reduced meas. distance (f< 30 MHz)

The used correction factors when the measurement distance is reduced compared to regulatory measurement distance, are calculated according Extrapolation formulas valid for EUT's with maximum dimension of 0.625xLambda. Formula 2+3+4 as presented in ANSI C63.10, Chapter 6.4.4 are used for the calculations of proper extrapolation factors.

Frequency Range	f [kHz/MHz]	Lambda [m]	Far-Field Point [m]	Distance Limit accord. 15.209 [m]	1st Condition (d _{meas} < D _{near-field})	2te Condition (Limit distance bigger d _{near-field})	Distance Correction accord. Formula
kHz	9,00E+03	33333,33	5305,17	300	fulfilled	not fulfilled	-80,00
	1,00E+04	30000,00	4774,65		fulfilled	not fulfilled	-80,00
	2,00E+04	15000,00	2387,33		fulfilled	not fulfilled	-80,00
	3,00E+04	10000,00	1591,55		fulfilled	not fulfilled	-80,00
	4,00E+04	7500,00	1193,66		fulfilled	not fulfilled	-80,00
	5,00E+04	6000,00	954,93		fulfilled	not fulfilled	-80,00
	6,00E+04	5000,00	795,78		fulfilled	not fulfilled	-80,00
	7,00E+04	4285,71	682,09		fulfilled	not fulfilled	-80,00
	8,00E+04	3750,00	596,83		fulfilled	not fulfilled	-80,00
	9,00E+04	3333,33	530,52		fulfilled	not fulfilled	-80,00
	1,00E+05	3000,00	477,47		fulfilled	not fulfilled	-80,00
	1,25E+05	2400,00	381,97		fulfilled	not fulfilled	-80,00
	2,00E+05	1500,00	238,73		fulfilled	fulfilled	-78,02
	3,00E+05	1000,00	159,16		fulfilled	fulfilled	-74,49
	4,00E+05	750,00	119,37		fulfilled	fulfilled	-72,00
	4,90E+05	612,24	97,44		fulfilled	fulfilled	-70,23
	5,00E+05	600,00	95,49		fulfilled	not fulfilled	-40,00
	6,00E+05	500,00	79,58		fulfilled	not fulfilled	-40,00
7,00E+05	428,57	68,21	fulfilled	not fulfilled	-40,00		
8,00E+05	375,00	59,68	fulfilled	not fulfilled	-40,00		
9,00E+05	333,33	53,05	fulfilled	not fulfilled	-40,00		
MHz	1,00	300,00	47,75	30	fulfilled	not fulfilled	-40,00
	1,59	188,50	30,00		fulfilled	not fulfilled	-40,00
	2,00	150,00	23,87		fulfilled	fulfilled	-38,02
	3,00	100,00	15,92		fulfilled	fulfilled	-34,49
	4,00	75,00	11,94		fulfilled	fulfilled	-32,00
	5,00	60,00	9,55		fulfilled	fulfilled	-30,06
	6,00	50,00	7,96		fulfilled	fulfilled	-28,47
	7,00	42,86	6,82		fulfilled	fulfilled	-27,13
	8,00	37,50	5,97		fulfilled	fulfilled	-25,97
	9,00	33,33	5,31		fulfilled	fulfilled	-24,95
	10,00	30,00	4,77		fulfilled	fulfilled	-24,04
	10,60	28,30	4,50		fulfilled	fulfilled	-23,53
	11,00	27,27	4,34		fulfilled	fulfilled	-23,21
	12,00	25,00	3,98		fulfilled	fulfilled	-22,45
	13,56	22,12	3,52		fulfilled	fulfilled	-21,39
	15,00	20,00	3,18		fulfilled	fulfilled	-20,51
	15,92	18,85	3,00		fulfilled	fulfilled	-20,00
	17,00	17,65	2,81		not fulfilled	fulfilled	-20,00
	18,00	16,67	2,65		not fulfilled	fulfilled	-20,00
	20,00	15,00	2,39		not fulfilled	fulfilled	-20,00
	21,00	14,29	2,27		not fulfilled	fulfilled	-20,00
23,00	13,04	2,08	not fulfilled	fulfilled	-20,00		
25,00	12,00	1,91	not fulfilled	fulfilled	-20,00		
27,00	11,11	1,77	not fulfilled	fulfilled	-20,00		
29,00	10,34	1,65	not fulfilled	fulfilled	-20,00		
30,00	10,00	1,59	not fulfilled	fulfilled	-20,00		

5.4. General Limit - Radiated field strength emissions, 30 MHz - 1 GHz

5.4.1. Test location and equipment

test location	<input checked="" type="checkbox"/> CETECOM Essen (Chapter. 2.2.1)	<input type="checkbox"/> Please see Chapter. 2.2.2	<input type="checkbox"/> Please see Chapter. 2.2.3
test site	<input checked="" type="checkbox"/> 441 EMISAR <input checked="" type="checkbox"/> 487 SAR NSA		
receiver	<input type="checkbox"/> 377 ESCS30 <input checked="" type="checkbox"/> 001 ESS	<input type="checkbox"/> 489 ESU 40	<input type="checkbox"/> 620 ESU 26
spectr. analys.	<input type="checkbox"/> 584 FSU <input type="checkbox"/> 120 FSEM	<input type="checkbox"/> 264 FSEK	
antenna	<input checked="" type="checkbox"/> 574 BTA-L <input type="checkbox"/> 133 EMCO3115	<input type="checkbox"/> 302 BBHA9170	<input type="checkbox"/> 289 CBL 6141 <input type="checkbox"/> 030 HFH-Z2 <input type="checkbox"/> 477 GPS
signaling	<input type="checkbox"/> 392 MT8820A <input type="checkbox"/> 371 CBT32	<input type="checkbox"/> 547 CMU	<input type="checkbox"/> 594 CMW
otherwise	<input type="checkbox"/> 400 FTC40x15E <input type="checkbox"/> 401 FTC40x15E	<input type="checkbox"/> 110 USB LWL	<input checked="" type="checkbox"/> 482 Filter Matrix
DC power	<input type="checkbox"/> 671 EA-3013S <input type="checkbox"/> 457 EA 3013A	<input type="checkbox"/> 459 EA 2032-50	<input type="checkbox"/> 268 EA- 3050 <input type="checkbox"/> 494 AG6632A <input type="checkbox"/> 498 NGPE
Supply voltage	<input type="checkbox"/> 230 V 50 Hz via public mains <input checked="" type="checkbox"/> 3.77 V DC (fully charged internal battery)		

5.4.2. Requirements/Limits

FCC		Part 15 Subpart C, §15.209, §15.407(b)(6)	
ISED (IC)		<input checked="" type="checkbox"/> RSS-Gen., Issue 5, table 5+7 <input type="checkbox"/> ICES-003, Issue 5, table 4 (class A) <input checked="" type="checkbox"/> RSS-247, Issue 2, Chapter 6.2	
ANSI		<input type="checkbox"/> C63.4-2014 <input checked="" type="checkbox"/> C63.10-2013	
Limit	Frequency [MHz]	Radiated emissions limits, 10 meters	
		QUASI-Peak [μ V/m]	QUASI-Peak [dB μ V/m]
	30-88	90	39.0
	88-216	150	43.5
	216-960	210	46.4
	above 960	300	49.5

5.4.3. Restricted bands of operation (FCC §15.205)

MHz	MHz	MHz	GHz
0.090-0.110	16.42-16.423	399.9-410	4.5-5.15
0.495-0.505	16.69475-16.69525	608-614	5.35-5.46
2.1735-2.1905	16.80425-16.80475	960-1240	7.25-7.75
4.125-4.128	25.5-25.67	1300-1427	8.025-8.5
4.20725-4.20775	37.5-38.25	1645.5-1646.5	9.3-9.5
6.215-6.218	73-74.6	1660-1710	10.6-12.7
6.26775-6.26825	74.8-75.2	1718.8-1722.2	13.25-13.4
6.31175-6.31225	108-121.94	2200-2300	14.47-14.5
8.291-8.294	123-138	2310-2390	15.35-16.2
8.362-8.366	149.9-150.05	2483.5-2500	17.7-21.4
8.37625-8.38675	156.52475-156.52525	2690-2900	22.01-23.12
8.41425-8.41475	156.7-156.9	3260-3267	23.6-24.0
12.29-12.293	162.0125-167.17	3332-3339	31.2-31.8
12.51975-12.52025	167.72-173.2	3345.8-3358	36.43-36.5
12.57675-12.57725	240-285	3600-4400	--
13.36-13.41	322-335.4	--	--

Remark: only spurious emissions are allowed within these frequency bands not exceeding the limits per §15.209

5.4.4. Test condition and measurement test set-up

Signal link to test system (if used):		<input type="checkbox"/> air link	<input type="checkbox"/> cable connection	<input checked="" type="checkbox"/> none
EUT-grounding		<input checked="" type="checkbox"/> none	<input type="checkbox"/> with power supply	<input type="checkbox"/> additional connection
Equipment set up		<input checked="" type="checkbox"/> table top 0.8m height		<input type="checkbox"/> floor standing
Climatic conditions		Temperature: (22±3°C)		Rel. humidity: (40±20)%
EMI-Receiver (Analyzer) Settings	Scan frequency range:	<input checked="" type="checkbox"/> 30 – 1000 MHz <input type="checkbox"/> other:		
	Scan-Mode	<input checked="" type="checkbox"/> 6 dB EMI-Receiver Mode <input type="checkbox"/> 3 dB spectrum analyser mode		
	Detector	Peak / Quasi-peak		
	RBW/VBW	100 kHz/300 kHz		
	Mode:	Repetitive-Scan, max-hold		
Scan step	80 kHz			
Sweep-Time	Coupled – calibrated display if continuous tx-signal otherwise adapted to EUT's individual duty-cycle			
General measurement procedures		Please see chapter “Test system set-up for electric field measurement in the range 30 MHz to 1 GHz”		

5.4.5. Radiated Field Strength Emissions – 30 MHz to 1 GHz Results

Table of measurement results:

Dia-gram no.	Carrier Channel		Frequency range	Set-up no.	OP-mode no.	Remark	Used detector			Result
	Range	No.					PK	AV	QP	
3.01a	Low	36	30 MHz – 1 GHz	1 + 3	1	18Mbit, EUT laying	<input checked="" type="checkbox"/>	<input type="checkbox"/>	<input type="checkbox"/>	passed
3.01b	Low	36	30 MHz – 1 GHz	1	1	18Mbit, EUT standing	<input checked="" type="checkbox"/>	<input type="checkbox"/>	<input type="checkbox"/>	passed
3.02b	high	48	30 MHz – 1 GHz	1	1	MCS4, EUT standing	<input checked="" type="checkbox"/>	<input type="checkbox"/>	<input type="checkbox"/>	passed
3.03b	Low	52	30 MHz – 1 GHz	1	1	MCS4, EUT standing	<input checked="" type="checkbox"/>	<input type="checkbox"/>	<input type="checkbox"/>	passed
3.04b	High	64	30 MHz – 1 GHz	1	1	18Mbit, EUT standing	<input checked="" type="checkbox"/>	<input type="checkbox"/>	<input type="checkbox"/>	passed
3.05	Low	100	30 MHz – 1 GHz	1	1	18Mbit, EUT standing	<input checked="" type="checkbox"/>	<input type="checkbox"/>	<input type="checkbox"/>	passed
3.06	Middle	140	30 MHz – 1 GHz	1	1	MCS4, EUT standing	<input checked="" type="checkbox"/>	<input type="checkbox"/>	<input type="checkbox"/>	passed
3.07	High	149	30 MHz – 1 GHz	1	1	18Mbit, EUT standing	<input checked="" type="checkbox"/>	<input type="checkbox"/>	<input type="checkbox"/>	passed
3.08	High	165	30 MHz – 1 GHz	1	1	MCS4, EUT standing	<input checked="" type="checkbox"/>	<input type="checkbox"/>	<input type="checkbox"/>	passed
3.04	Low	36	30 MHz – 1 GHz	3	1	MCS4, EUT standing	<input checked="" type="checkbox"/>	<input type="checkbox"/>	<input type="checkbox"/>	passed

Remark: for further details see Annex 1 (18-1-0050701T04-A1)

5.5. General Limit - Radiated emissions, above 1 GHz

5.5.1. Test location and equipment FAR

test site	<input type="checkbox"/> 441 EMI SAR	<input type="checkbox"/> 348 EMI cond.	<input checked="" type="checkbox"/> 443 EMI FAR	<input type="checkbox"/> 347 Radio.lab.	<input type="checkbox"/> 337 OATS	<input type="checkbox"/>
spectr. analys.	<input type="checkbox"/> 584 FSU	<input type="checkbox"/> 120 FSEM	<input type="checkbox"/> 264 FSEK	<input checked="" type="checkbox"/> 489 ESU 40	<input type="checkbox"/>	<input type="checkbox"/>
antenna meas	<input type="checkbox"/> 574 BTA-L	<input type="checkbox"/> 289 CBL 6141	<input type="checkbox"/> 608 HL 562	<input checked="" type="checkbox"/> 549 HL025	<input checked="" type="checkbox"/> 302 BBHA9170	<input type="checkbox"/> 477 GPS
antenna meas	<input type="checkbox"/> 123 HUF-Z2	<input type="checkbox"/> 132 HUF-Z3	<input type="checkbox"/> 030 HFH-Z2	<input checked="" type="checkbox"/> 376 BBHA9120E		<input type="checkbox"/>
antenna subst	<input type="checkbox"/> 071 HUF-Z2	<input type="checkbox"/> 020 EMCO3115	<input type="checkbox"/> 063 LP 3146	<input type="checkbox"/> 303 BBHA9170	<input type="checkbox"/>	<input type="checkbox"/>
multimeter	<input type="checkbox"/> 341 Fluke 112	<input type="checkbox"/>	<input type="checkbox"/>	<input type="checkbox"/>	<input type="checkbox"/>	<input type="checkbox"/>
signaling	<input type="checkbox"/> 392 MT8820A	<input type="checkbox"/> 371 CBT32	<input type="checkbox"/> 547 CMU	<input type="checkbox"/> 594 CMW		
DCpower	<input type="checkbox"/> 611 E3632A	<input type="checkbox"/> 087 EA3013	<input type="checkbox"/> 354 NGPE 40	<input type="checkbox"/> 349 car battery	<input type="checkbox"/> 350 Car battery	<input type="checkbox"/>
Supply voltage	<input type="checkbox"/> 230 V 50 Hz via public mains		<input checked="" type="checkbox"/> 3.77 V DC (fully charged internal battery)			

5.5.2. Requirements/Limits

FCC	<input type="checkbox"/> Part 15 Subpart B, §15.109 class B <input checked="" type="checkbox"/> Part 15 Subpart C, §15.209 for frequencies defined in §15.205 <input type="checkbox"/> Part 15 Subpart C, §15.407(b)(1)(2)(3)(4)			
ISED	<input checked="" type="checkbox"/> RSS-Gen., Issue 5, Chapter 8.9, Table 5+6+7 (transmitter licence exempt) <input type="checkbox"/> RSS-Gen., Issue 5, Chapter 7.3, Table 3 (receiver) <input type="checkbox"/> ICES-003, Issue 6, Chapter 6.2.2, Table 7 (class B) <input type="checkbox"/> RSS-247, Issue 2, Chapter 5.5 <input checked="" type="checkbox"/> RSS-247, Issue 2, Chapter 6.2			
ANSI	<input type="checkbox"/> C63.4-2014 <input checked="" type="checkbox"/> C63.10-2013			
Frequency [MHz]	Limits			
	AV [µV/m]	AV [dBµV/m]	Peak [µV/m]	Peak [dBµV/m] or [dBm/MHz]
above 1 GHz for frequencies as defined in §15.205 or RSS-Gen., Issue 9, §8.9 - Table 5	500	54.0	5000	74.0 dBµV/m
§15.407(b)(1)(2)(3)(4)	--	--	--	(b)(1): 5.15-5.25GHz: -27dBm eirp (b)(2): 5.25-5.35GHz: -27dBm eirp (b)(3): 5.47-5.725 GHz: -27dBm eirp (-17dBm/MHz eirp) (b)(4): 5.725-5.85GHz: Spectrum mask
RSS-247, Issue 2	--	--	--	§6.2.1.2 §6.2.2.2 §6.2.3.3 §6.2.4.2: Spectrum mask 27 to 15.6dBm 15.6dBm to 10dBm

5.5.3. Test condition and measurement test set-up

Signal link to test system (if used):	<input type="checkbox"/> air link	<input type="checkbox"/> cable connection	<input checked="" type="checkbox"/> none
EUT-grounding	<input checked="" type="checkbox"/> none	<input type="checkbox"/> with power supply	<input type="checkbox"/> additional connection
Equipment set up	<input checked="" type="checkbox"/> table top 1.5m height		<input type="checkbox"/> floor standing
Climatic conditions	Temperature: (22±3°C)		Rel. humidity: (40±20)%
Spectrum-Analyzer settings	Scan frequency range: <input checked="" type="checkbox"/> 1 – 18 GHz <input type="checkbox"/> 18 – 25 GHz <input checked="" type="checkbox"/> 18 – 40 GHz <input type="checkbox"/> other: Scan-Mode: <input checked="" type="checkbox"/> 6 dB EMI-Receiver Mode <input type="checkbox"/> 3 dB Spectrum analyser Mode Detector: Peak and Average RBW/VBW: 1 MHz / 3 MHz Mode: Repetitive-Scan, max-hold Scan step: 400 kHz Sweep-Time: Coupled – calibrated display if CW signal otherwise adapted to EUT's individual duty-cycle		
General measurement procedures	Please see chapter "Test system set-up for radiated electric field measurements above 1 GHz"		

5.5.4. Radiated Field Strength Emissions Results:

Dia-gram no.	Carrier Channel		Frequency range	Set-up no.	OP-mode no.	Remark	Used detector			Result
	Range	No.					PK	AV	QP	
4.01a	Low	36	1-7GHz	1	1	18Mbit	<input checked="" type="checkbox"/>	<input checked="" type="checkbox"/>	<input type="checkbox"/>	passed
4.02a	High	48				MCS4	<input checked="" type="checkbox"/>	<input checked="" type="checkbox"/>	<input type="checkbox"/>	passed
4.03a	Low	52				MCS4	<input checked="" type="checkbox"/>	<input checked="" type="checkbox"/>	<input type="checkbox"/>	passed
4.04a	High	64				18Mbit	<input checked="" type="checkbox"/>	<input checked="" type="checkbox"/>	<input type="checkbox"/>	passed
4.05a	Low	100				18Mbit	<input checked="" type="checkbox"/>	<input checked="" type="checkbox"/>	<input type="checkbox"/>	passed
4.06b	High	140				MCS4	<input checked="" type="checkbox"/>	<input checked="" type="checkbox"/>	<input type="checkbox"/>	passed
4.06a	high	165				MCS4	<input checked="" type="checkbox"/>	<input checked="" type="checkbox"/>	<input type="checkbox"/>	passed
4.07a	low	149				18Mbit	<input checked="" type="checkbox"/>	<input checked="" type="checkbox"/>	<input type="checkbox"/>	passed
8.04a	Low	36				3	MCS4	<input checked="" type="checkbox"/>	<input checked="" type="checkbox"/>	<input type="checkbox"/>

Remark:

- 1.) see diagrams in annex 1 for more details
- 2.) Results valid with power 12.5 power setting, see document JTA6DG Test instructions

Dia-gram no.	Carrier Channel		Frequency range	Set-up no.	OP-mode no.	Remark	Used detector			Result
	Range	No.					PK	AV	QP	
8.01b	Low	36	7-18 GHz	1	1	18Mbit	<input checked="" type="checkbox"/>	<input checked="" type="checkbox"/>	<input type="checkbox"/>	passed
8.02b	High	48				MCS4	<input checked="" type="checkbox"/>	<input checked="" type="checkbox"/>	<input type="checkbox"/>	passed
8.03b	Low	52				MCS4	<input checked="" type="checkbox"/>	<input checked="" type="checkbox"/>	<input type="checkbox"/>	passed
8.04b	High	64				18Mbit	<input checked="" type="checkbox"/>	<input checked="" type="checkbox"/>	<input type="checkbox"/>	passed
8.05b	Low	100				18Mbit	<input checked="" type="checkbox"/>	<input checked="" type="checkbox"/>	<input type="checkbox"/>	passed
8.06b	high	140				MCS4	<input checked="" type="checkbox"/>	<input checked="" type="checkbox"/>	<input type="checkbox"/>	passed
8.07b	low	149				18Mbit	<input checked="" type="checkbox"/>	<input checked="" type="checkbox"/>	<input type="checkbox"/>	passed
8.08b	high	165				MCS4	<input checked="" type="checkbox"/>	<input checked="" type="checkbox"/>	<input type="checkbox"/>	passed
4.04b	Low	36				3	MCS4	<input checked="" type="checkbox"/>	<input checked="" type="checkbox"/>	<input type="checkbox"/>

Remark:

- 1.) see diagrams in annex 1 for more details
- 2.) Results valid with power 12.5 setting, see document JTA6DG Test instructions
- 3.) for

Diagram no.	Carrier Channel		Frequency range	Set-up no.	OP-mode no.	Remark	Used detector			Result
	Range	No.					PK	AV	QP	
4.10c	Low	36	18-40 GHz	1	1	a-Mode, 18Mbit	<input checked="" type="checkbox"/>	<input checked="" type="checkbox"/>	<input type="checkbox"/>	passed
4.11c	High	48				n-Mode, MCS4	<input checked="" type="checkbox"/>	<input checked="" type="checkbox"/>	<input type="checkbox"/>	passed
4.12c	Low	52				n-Mode, MCS4	<input checked="" type="checkbox"/>	<input checked="" type="checkbox"/>	<input type="checkbox"/>	passed
4.13c	High	64				a-Mode, 18Mbit	<input checked="" type="checkbox"/>	<input checked="" type="checkbox"/>	<input type="checkbox"/>	passed
4.14c	Low	100				a-Mode, 18Mbit	<input checked="" type="checkbox"/>	<input checked="" type="checkbox"/>	<input type="checkbox"/>	passed
4.15c	high	140				n-Mode, MCS4	<input checked="" type="checkbox"/>	<input checked="" type="checkbox"/>	<input type="checkbox"/>	passed
4.16b	low	149				a-Mode, 18Mbit	<input checked="" type="checkbox"/>	<input checked="" type="checkbox"/>	<input type="checkbox"/>	passed
4.17b	high	165				n-Mode, MCS4	<input checked="" type="checkbox"/>	<input checked="" type="checkbox"/>	<input type="checkbox"/>	passed
4.04c	Low	36		3		MCS4	<input checked="" type="checkbox"/>	<input checked="" type="checkbox"/>	<input type="checkbox"/>	passed

Remark:

- 1.) see diagrams in annex 1 for more details
- 2.) Results valid with power 12.5 setting, see document JTA6DG Test instructions

5.6. RF-Parameter - Radiated Band-Edge compliance measurements

5.6.1. Test location and equipment FAR

test site	<input type="checkbox"/> 441 EMI SAR	<input type="checkbox"/> 348 EMI cond.	<input checked="" type="checkbox"/> 443 EMI FAR	<input type="checkbox"/> 347 Radio.lab.	<input type="checkbox"/> 337 OATS	<input type="checkbox"/>
spectr. analys.	<input type="checkbox"/> 584 FSU	<input type="checkbox"/> 120 FSEM	<input type="checkbox"/> 264 FSEK	<input checked="" type="checkbox"/> 489 ESU 40	<input type="checkbox"/>	<input type="checkbox"/>
antenna meas	<input type="checkbox"/> 574 BTA-L	<input type="checkbox"/> 289 CBL 6141	<input type="checkbox"/> 608 HL 562	<input checked="" type="checkbox"/> 549 HL025	<input type="checkbox"/> 302 BBHA9170	<input type="checkbox"/> 477 GPS
antenna meas	<input type="checkbox"/> 123 HUF-Z2	<input type="checkbox"/> 132 HUF-Z3	<input type="checkbox"/> 030 HFH-Z2	<input type="checkbox"/>	<input type="checkbox"/>	<input type="checkbox"/>
antenna subst	<input type="checkbox"/> 071 HUF-Z2	<input type="checkbox"/> 020 EMCO3115	<input type="checkbox"/> 063 LP 3146	<input type="checkbox"/> 303 BBHA9170	<input type="checkbox"/>	<input type="checkbox"/>
multimeter	<input type="checkbox"/> 341 Fluke 112	<input type="checkbox"/>	<input type="checkbox"/>	<input type="checkbox"/>	<input type="checkbox"/>	<input type="checkbox"/>
signaling	<input type="checkbox"/> 392 MT8820A	<input type="checkbox"/> 371 CBT32	<input type="checkbox"/> 547 CMU	<input type="checkbox"/> 594 CMW	<input type="checkbox"/>	<input type="checkbox"/>
DC power	<input type="checkbox"/> 611 E3632A	<input type="checkbox"/> 087 EA3013	<input type="checkbox"/> 354 NGPE 40	<input type="checkbox"/> 349 car battery	<input type="checkbox"/> 350 Car battery	<input type="checkbox"/>
Supply voltage	<input type="checkbox"/> 230 V 50 Hz via public mains		<input checked="" type="checkbox"/> 3.77 V DC (fully charged internal battery)			

5.6.2. Requirements/Limits

FCC	<input type="checkbox"/> Part 15 Subpart B, §15.109 class B <input checked="" type="checkbox"/> Part 15 Subpart C, §15.209 for frequencies defined in §15.205 <input type="checkbox"/> Part 15 Subpart C, §15.407(b)(1)(2)(3)(4)			
ISED	<input checked="" type="checkbox"/> RSS-Gen., Issue 5, Chapter 8.9, Table 5+6+7 (transmitter licence exempt) <input type="checkbox"/> RSS-Gen., Issue 5, Chapter 7.3, Table 3 (receiver) <input type="checkbox"/> ICES-003, Issue 6, Chapter 6.2.2, Table 7 (class B) <input type="checkbox"/> RSS-247, Issue 2, Chapter 5.5 <input checked="" type="checkbox"/> RSS-247, Issue 2, Chapter 6.2			
ANSI	<input type="checkbox"/> C63.4-2014 <input checked="" type="checkbox"/> C63.10-2013			
Frequency [MHz]	Limits			
	AV [µV/m]	AV [dBµV/m]	Peak [µV/m]	Peak [dBµV/m] or [dBm/MHz]
above 1 GHz for frequencies as defined in §15.205 or RSS-Gen., Issue 9, §8.9 - Table 5	500	54.0	5000	74.0 dBµV/m
§15.407(b)(1)(2)(3)(4)	--	--	--	(b)(1): 5.15-5.25GHz: -27dBm eirp (b)(2): 5.25-5.35GHz: -27dBm eirp (b)(3): 5.47-5.725 GHz: -27dBm eirp (-17dBm/MHz eirp) (b)(4): 5.725-5.85GHz: Spectrum mask
RSS-247, Issue 2	--	--	--	§6.2.1.2 §6.2.2.2 §6.2.3.3 §6.2.4.2: Spectrum mask 27 to 15.6dBm 15.6dBm to 10dBm

5.6.3. Test condition and measurement test set-up

Signal link to test system (if used):	<input type="checkbox"/> air link	<input type="checkbox"/> cable connection	<input checked="" type="checkbox"/> none
EUT-grounding	<input checked="" type="checkbox"/> none	<input type="checkbox"/> with power supply	<input type="checkbox"/> additional connection
Equipment set up	<input checked="" type="checkbox"/> table top 1.5m height		<input type="checkbox"/> floor standing
Climatic conditions	Temperature: (22±3°C)		Rel. humidity: (40±20)%
Spectrum-Analyzer settings	Scan frequency range: <input type="checkbox"/> 1 – 18 GHz <input type="checkbox"/> 18 – 25 GHz <input type="checkbox"/> 18 – 40 GHz <input checked="" type="checkbox"/> other: see diagrams Scan-Mode: <input type="checkbox"/> 6 dB EMI-Receiver Mode <input checked="" type="checkbox"/> 3 dB Spectrum analyzer Mode Detector: Peak and Average RBW/VBW: Left band-edge: 100kHz/300kHz Right band-edge: 1 MHz / 3 MHz Mode: Repetitive-Scan, max-hold Scan step: 40kHz or 400 kHz Sweep-Time: Coupled – calibrated display if CW signal otherwise adapted to EUT's individual duty-cycle		
General measurement procedures	Please see chapter "Test system set-up for radiated electric field measurements above 1 GHz" for general measurements procedures in anechoic chamber.		

5.6.4. Measurement Method

For uncritical results where a measurement resolution bandwidth of 1MHz can clearly show the compliance without influencing the results, a field strength measurement was performed to show compliance.

For critical results a Marker-Delta marker method was used for showing compliance to restricted bands. The method is according ANSI C63.10:2013, Chapter 6.10.6 “Marker-Delta method”. The method consists of three independent steps:

- 1. Step:** Prior to the measurement the fundamental radiated In-Band field strength was performed. The determined value is used as reference value.
- 2. Step:** Second step consist of finding the relative attenuation between the fundamental emission and the maximum local out-of-band emission (within 2 MHz range around the band edge either on the band-edge directly or some modulation product if the level is greater than that on the band-edge) when measured with lower resolution bandwidth.
- 3. Step:** The delta value recorded in step 2 will be subtracted from value recorded in step 1, thus giving the required field strength at the band-edge. This value must fulfil the requirements for radiated spurious emissions in restricted bands in FCC §15.205 with the general limits of FCC §15.209.

5.6.5. EUT settings

The EUT was instructed to send with maximum power (if adjustable) according to applicants instructions, see document **JTA6DG Test instructions**

5.6.6. Results:

5.6.6.1. Non-restricted bands - limits according to FCC §15.407 /RSS-247, Issue 2

Diagram no.	Channel no.	Restricted band ?	Fundamental Value [dBuV/m]		Peak-Value at Band-Edge [dBuV/m]	Limit [dBuV/m @3m]	Margin [dB]	Verdict	Remark:
			Peak -Value	Average -Value					
9.05	100	no	104,19	93,56	61,0	68,2	7,2	PASS	PWR-VALUE=12.5 dBm used
9.06	140	no	101,96	90,75	59,8	68,2	8,4	PASS	PWR-VALUE=12.5 dBm used
9.07	149	no	98,99	88,06	67,6	122,2	54,6	PASS	PWR-VALUE=12.5 dBm used
9.08	165	no	99,46	88,56	61,1	122,2	61,1	PASS	PWR-VALUE=12.5 dBm used
9.13	100	no	105,05	94,1	57,17	68,2	11,03	PASS	PWR-VALUE=12.5 dBm used
9.14	140	no	102,16	90,37	59,8	68,2	8,4	PASS	PWR-VALUE=12.5 dBm used
9.15	149	no	98,94	88,29	69,0	122,2	53,2	PASS	PWR-VALUE=12.5 dBm used
9.16	165	no	100,13	88,92	61,89	122,2	60,31	PASS	PWR-VALUE=12.5 dBm used

Handheld Variant

Diagram no.	Channel no.	Restrict ed band ?	Fundamental Value [dBuV/m]		Peak-Value at Band-Edge [dBuV/m]	Limit [dBuV/m@ 3m]	Margin [dB]	Verdict	Remark:
			Peak -Value	Average -Value					
9.09	100	no	102,99	91,214	61,1	68,2	7,1	PASS	HH Variant PWR-VALUE=12.5 dBm used
9.10	140	no	100,92	91,337	59,8	68,2	8,4	PASS	HH Variant PWR-VALUE=12.5 dBm used
9.11	149	no	98,53	85,198	68,9	122,2	53,3	PASS	HH Variant PWR-VALUE=12.5 dBm used

Limit for channels 100/140: -27dBm/MHz (68.2 dBµV/m at 3m measurement distance)

Limit for channels 149/165: 27dBm/MHz (122.2 dBµV/m at 3m measurement distance)

5.6.6.2. Results for restricted bands near-by with limits accord. FCC §15.205 / §15.209

Diagramm no.	Channel no.	Restricted band ?	Fundamental Value		Value at Band-Edge		Limits		Duty-Cycle [dB]	Margin		Verdict	Remark:
			Peak-Value	Average-Value	Peak -Value	Average -Value	Peak -Value	Average -Value		Peak	Average		
9.01	36	yes	102,73	93,23	57,0	44,0	74	54	1,55	17	8,5	PASS	PWR-Level 12.5 dBm used
9.02	48	yes	102,26	91,73	52,23	40,3	74	54	1,55	21,77	12,15	PASS	PWR-Level 12.5 dBm used
9.04	64	yes	102,45	91,89	54,51	42,13	74	54	1,55	19,49	10,32	PASS	PWR-Level 12.5 dBm used
9.09	36	yes	103,44	93,03	57,35	44,2	74	54	2,62	16,65	7,18	PASS	PWR-Level 12.5dBm used
9.10	48	yes	87,43	78,27	52,0	40,0	74	54	2,62	22	11,38	PASS	PWR-Level 12.5 dBm used
9.12	64	yes	102,93	91,35	56,13	42,69	74	54	2,62	17,87	8,69	PASS	PWR-Level 12.5 dBm used

HH Variant Spot checks

Diagramm no.	Channel no.	Restricted band ?	Fundamental Value		Value at Band-Edge		Limits		Duty-Cycle [dB]	Margin		Verdict	Remark:
			Peak-Value	Average-Value	Peak -Value	Average -Value	Peak -Value	Average -Value		Peak	Average		
9.07	36	yes	99,49	89,229	59,8	44,8	74	54	1,55	14,203	7,7	PASS	HH Variant PWR-Level 12.5 dBm used
9.08	64	yes	96,564	87,58	55,081	42,881	74	54	1,55	18,919	9,569	PASS	HH Variant PWR-Level 12.5 dBm used

5.6.7. Results for restricted emissions in 5250-5350MHz band when TX operable in 5150-5250MHz band

Requirement Canada RSS-247, Issue 2, Chapter 6.2.1.2

See annex 1 for results and calculations (Diagram 3 and 4)

Verdict: pass

5.6.8. Results for restricted power density in 5150-5250MHz band when TX operable in 5250-5350MHz band

Requirement Canada RSS-247, Issue 2, Chapter 6.2.2.2 b)

Diagram 9.03 and 9.11 - Max. power density at 5250MHz point on operable channel 52: -10.7dBm/MHz < 10dBm/MHz

Verdict: pass with restriction to labelling requirement

Device must be labelled: “for indoor use only

5.6.9. Verdict: Pass

5.7. Measurement uncertainties

The reported uncertainties are calculated based on the standard uncertainty multiplied with the appropriate coverage factor **k**, such that a confidence level of approximately 95% is achieved.

For uncertainty determination, each component used in the concrete measurement set-up was taken in account and it's contribution to the overall uncertainty according it's statistical distribution calculated.

Following table shows expectable uncertainties for each measurement type performed.

RF-Measurement	Reference	Frequency range	Calculated uncertainty based on a confidence level of 95%						Remarks
Conducted emissions (U _{CISPR})	CISPR 16-2-1	9 kHz - 150 kHz	4.0 dB						-
		150 kHz - 30 MHz	3.6 dB						
Radiated emissions Enclosure	CISPR 16-2-3	30 MHz - 1 GHz	4.2 dB						E-Field
		1 GHz - 18 GHz	5.1 dB						
Disturbance power	CISPR 16-2-2	30 MHz - 300 MHz	-						-
Power Output radiated	-	30 MHz - 4 GHz	3.17 dB						Substitution method
Power Output conducted	-	Set-up No.	Cel-C1	Cel-C2	BT1	W1	W2	--	-
		9 kHz - 12.75 GHz	N/A	0.60	0.7	0.25	N/A	--	
		12.75 - 26.5GHz	N/A	0.82	--	N/A	N/A	--	
Conducted emissions on RF-port	-	9 kHz - 2.8 GHz	0.70	N/A	0.70	N/A	0.69	--	N/A - not applicable
		2.8 GHz - 12.75GHz	1.48	N/A	1.51	N/A	1.43	--	
		12.75 GHz - 18GHz	1.81	N/A	1.83	N/A	1.77	--	
		18 GHz - 26.5GHz	1.83	N/A	1.85	N/A	1.79	--	
Occupied bandwidth	-	9 kHz - 4 GHz	0.1272 ppm (Delta Marker)						Frequency error
			1.0 dB						Power
Emission bandwidth	-	9 kHz - 4 GHz	0.1272 ppm (Delta Marker)						Frequency error
			See above: 0.70 dB						Power
Frequency stability	-	9 kHz - 20 GHz	0.0636 ppm						-
Radiated emissions Enclosure	-	150 kHz - 30 MHz	5.0 dB						Magnetic field E-field Substitution
		30 MHz - 1 GHz	4.2 dB						
		1 GHz - 20 GHz	3.17 dB						

Table: measurement uncertainties, valid for conducted/radiated measurements

6. Abbreviations used in this report

The abbreviations	
ANSI	American National Standards Institute
AV . AVG. CAV	Average detector
EIRP	Equivalent isotropically radiated power. determined within a separate measurement
EGPRS	Enhanced General Packet Radio Service
EUT	Equipment Under Test
FCC	Federal Communications Commission. USA
IC	Industry Canada
n.a.	not applicable
Op-Mode	Operating mode of the equipment
PK	Peak
RBW	resolution bandwidth
RF	Radio frequency
RSS	Radio Standards Specification. Documents from Industry Canada
Rx	Receiver
TCH	Traffic channel
Tx	Transmitter
QP	Quasi peak detector
VBW	Video bandwidth
ERP	Effective radiated power

7. Accreditation details of CETECOM's laboratories and test sites

Ref.-No.	Accreditation Certificate	Valid for laboratory area or test site	Accreditation Body
-	D-PL-12047-01-01	All laboratories and test sites of CETECOM GmbH. Essen	DAkKS. Deutsche Akkreditierungsstelle GmbH
337 487 558 348 348	(MRA US-EU 0003)	Radiated Measurements 30 MHz to 1 GHz. 3 m / 10 m (OATS) Radiated Measurements 30 MHz to 1 GHz. 3 m (SAR) Radiated Measurements above 1 GHz. 3 m (FAR) Mains Ports Conducted Interference Measurements Telecommunication Ports Conducted Interference Measurment.	FCC. Federal Communications Commission Laboratory Division. USA
337 487 550 558	3462D-1 3462D-2 3462D-2 3462D-3	Radiated Measurements 30 MHz to 1 GHz. 3 m / 10 m (OATS) Radiated Measurements 30 MHz to 1 GHz. 3 m (SAR) Radiated Measurements 1 GHz to 6 GHz. 3 m (SAR) Radiated Measurements above 1 GHz. 3 m (FAR)	IC. Industry Canada Certification and Engineering Bureau
487 550 348 348	R-2666 G-301 C-2914 T-1967	Radiated Measurements 30 MHz to 1 GHz. 3 m (SAR) Radiated Measurements 1 GHz to 6 GHz. 3 m (SAR) Mains Ports Conducted Interference Measurements Telecommunication Ports Conducted Interference Measurment.	VCCI. Voluntary Control Council for Interference by Information Technology Equipment. Japan

OATS = Open Area Test Site. SAR = Semi Anechoic Room. FAR = Fully Anechoic Room

8. Instruments and Ancillary

TC”

The “Ref.-No” in the left column of the following tables allows the clear identification of the laboratory equipment.

8.1.1. Test software and firmware of equipment

Ref.-No.	Equipment	Type	Serial-No.	Version of Firmware or Software during the test
001	EMI Test Receiver	ESS	825132/017	Firm.= 1.21 , OTP=2.0, GRA=2.0
012	Signal Generator (EMS-cond.)	SMY 01	839069/027	Firm.= V 2.02
013	Power Meter (EMS cond.)	NRVD	839111/003	Firm.= V 1.51
017	Digital Radiocommunication Tester	CMD 60 M	844365/014	Firmware = V 3.52 .22.01.99, DECT = D2.87 13.01.99
053	Audio Analyzer	UPA3	860612/022	Firm. V 4.3
119	RT Harmonics Analyzer dig. Flickermeter	B10	G60547	Firm.= V 3.1DHG
140	Signal Generator	SMHU	831314/006	Firm.= 3.21
261	Thermal Power Sensor	NRV-Z55	825083/0008	EPROM-Datum 02.12.04, SE EE 1 B
262	Power Meter	NRV-S	825770/0010	Firm.= 2.6
263	Signal Generator	SMP 04	826190/0007	Firm.=3.21
295	Racal Digital Radio Test Set	6103	1572	UNIT Firmware= 4.04, SW-Main=4.04, SW-BBP=1.04, SW-DSP=1.02, Hardboot=1.02, Softboot=2.02
298	Univ. Radio Communication Tester	CMU 200	832221/091	R&S Test Firmware =3.53 /3.54 (current Testsoftw. f. all band used
323	Digital Radiocommunication Tester	CMD 55	825878/0034	Firm.= 3.52 .22.01.99
335	CTC-EMS-Conducted	System EMS Conducted	-	EMC 32 V 8.52
340	Digital Radiocommunication Tester	CMD 55	849709/037	Firm.= 3.52 .22.01.99
355	Power Meter	URV 5	891310/027	Firm.= 1.31
365	10V Insertion Unit 50 Ohm	URV5-Z2	100880	Eprom Data = 31.03.08
366	Ultra Compact Simulator	UCS 500 M4	V0531100594	Firm. UCS 500=001925/3.06a02, rc=ISMIEC 4.10
371	Bluetooth Tester	CBT32	100153	CBT V5.30+ SW-Option K55, K57
377	EMI Test Receiver	ESCS 30	100160	Firm.= 2.30, OTP= 02.01, GRA= 02.36
378	Broadband RF Field Monitor	RadiSense III	03D00013SNO-08	Firm.= V.03D13
389	Digital Multimeter	Keithley 2000	0583926	Firm. = A13 (Mainboard) A02 (Display)
392	Radio Communication Tester	MT8820A	6K00000788	Firm.= 4.50 #005, IPL=4.01#001, OS=4.02#001, GSM=4.41#013, W-CDMA= 4.54#004, scenario= 4.52#002
436	Univ. Radio Communication Tester	CMU 200	103083	R&S Test Firmware Base=5.14, Mess-Software= GSM:5.14 WCDMA:5.14 (current Testsoftw. F. all band
441	CTC-SAR-EMI Cable Loss	System EMI field (SAR)	-	EMC 32 Version 8.52
442	CTC-SAR-EMS	System EMS field (SAR)	-	EMC 32 Version 8.40
443	CTC-FAR-EMI-RSE	System CTC-FAR-EMI-RSE	-	Spuri 7.2.5 or EMC 32 Ver. 9.15.00
444	CTC-FAR-EMS field	System-EMS-Field (FAR)	-	EMC 32 Version 9.15.00
460	Univ. Radio Communication Tester	CMU 200	108901	R&S Test Firmware Base=5.14, GSM=5.14 WCDMA=5.14 (current Testsoftw..f. all band to be used,
489	EMI Test Receiver	ESU40	1000-30	Firmware=4.43 SP3, Bios=V5.1-16-3, Spec. =01.00
491	ESD Simulator dito	ESD dito	dito307022	V 2.30
524	Voltage Drop Simulator	VDS 200	0196-16	Software Nr: 000037 Version V4.20a01
526	Burst Generator	EFT 200 A	0496-06	Software Nr. 000034 Version V2.32
527	Micro Pulse Generator	MPG 200 B	0496-05	Software-Nr. 000030 Version V2.43
528	Load Dump Simulator	LD 200B	0496-06	Software-Nr. 000031 Version V2.35a01
546	Univ. Radio Communication Tester	CMU 200	106436	R&S Test Firmware Base=5.14, GSM=5.14 WCDMA=5.14 (current Testsoftw..f. all band to be used
547	Univ. Radio Communication Tester	CMU 200	835390/014	R&S Test Firmware Base=V5.1403 (current Testsoftw., f. all band used, GSM = 5.14 WCDMA: = 5.14
584	Spectrum Analyzer	FSU 8	100248	2.82_SP3
597	Univ. Radio Communication Tester	CMU 200	100347	R&S Test Firmware Base=5.01, GSM=5.02 WCDMA= not installed, Mainboard= µP1=V.850
598	Spectrum Analyzer	FSEM 30	831259/013	Firmware Bios 3.40 , Analyzer 3.40 Sp 2
607	Signal Generator	SMR 20	832033/011	V1.25
620	EMI Test Receiver	ESU 26	100362	4.43_SP3
642	Wideband Radio Communication Tester	CMW 500	126089	Setup V03.26, Test programm component V03.02.20
670	Univ. Radio Communication Tester	CMU 200	106833	µP1 =V8.50, Firmware = V.20
689	Vector Signal Generator	SMU200	100970	02.20.360.142
692	Bluetooth Tester	CBT 32	100236	CBT V 5.40, FW: V.2.41 (FPGA Digital, V. 3.09 FPGA RF)

8.1.2. Single instruments and test systems

Ref.-No.	Equipment	Type	Serial-No.	Manufacturer	Interval of calibration	Remark	Cal due
001	EMI Test Receiver	ESS	825132/017	Rohde & Schwarz	12 M	-	16.05.2019
005	AC - LISN (50 Ohm/50µH, test site 1)	ESH2-Z5	861741/005	Rohde & Schwarz	12 M	-	16.05.2019
007	Single-Line V-Network (50 Ohm/5µH)	ESH3-Z6	892563/002	Rohde & Schwarz	12 M	-	16.05.2019
009	Power Meter (EMS-radiated)	NRV	863056/017	Rohde & Schwarz	24 M	-	15.05.2019
016	Line Impedance Simulating Network	Op. 24-D	B6366	Spitzenberger+Spies	36 M	-	30.05.2019
020	Horn Antenna 18 GHz (Subst 1)	3115	9107-3699	EMCO	36/12 M	-	31.07.2021
021	Loop Antenna (H-Field)	6502	9206-2770	EMCO	36 M	-	30.05.2021
030	Loop Antenna (H-field)	HFH-Z2	879604/026	Rohde & Schwarz	36 M	-	30.04.2018
033	RF-current probe (100kHz-30MHz)	ESH2-Z1	879581/18	Rohde & Schwarz	24 M	-	15.05.2019
057	relay-switch-unit (EMS system)	RSU	494440/002	Rohde & Schwarz	pre-m	1a	
060	power amplifier (DC-2kHz)	PAS 5000	B6363	Spitzenberger+Spies	-	3	
086	DC - power supply, 0 -10 A	LNG 50-10	-	Heinzinger Electronic	pre-m	2	
087	DC - power supply, 0 -5 A	EA-3013 S	-	Elektro Automatik	pre-m	2	
091	USB-LWL-Converter	OLS-1	007/2006	Ing. Büro Scheiba	-	4	
099	passive voltage probe	ESH2-Z3	299.7810.52	Rohde & Schwarz	36 M	-	30.05.2021
100	passive voltage probe	Probe TK 9416	without	Schwarzbeck	36 M	-	30.05.2021
110	USB-LWL-Converter	OLS-1	-	Ing. Büro Scheiba	-	4	
119	RT Harmonics Analyzer dig. Flickermeter	B10	G60547	BOCONSULT	36 M	-	30.05.2019
133	horn antenna 18 GHz (Meas 1)	3115	9012-3629	EMCO	36 M	1c	10.03.2020
134	horn antenna 18 GHz (Subst 2)	3115	9005-3414	EMCO	36 M	-	10.03.2020
248	attenuator	SMA 6dB 2W	-	Radiall	pre-m	2	
249	attenuator	SMA 10dB 10W	-	Radiall	pre-m	2	
252	attenuator	N 6dB 12W	-	Radiall	pre-m	2	
256	attenuator	SMA 3dB 2W	-	Radiall	pre-m	2	
257	hybrid	4031C	04491	Narda	pre-m	2	
260	hybrid coupler	4032C	11342	Narda	pre-m	2	
261	Thermal Power Sensor	NRV-Z55	825083/0008	Rohde & Schwarz	24 M	-	30.05.2020
262	Power Meter	NRV-S	825770/0010	Rohde & Schwarz	24 M	-	30.05.2019
263	Signal Generator	SMP 04	826190/0007	Rohde & Schwarz	36 M	-	30.05.2019
265	peak power sensor	NRV-Z33, Model 04	840414/009	Rohde & Schwarz	24 M	-	30.05.2020
266	Peak Power Sensor	NRV-Z31, Model 04	843383/016	Rohde & Schwarz	24 M	-	30.05.2020
267	notch filter GSM 850	WRCA 800/960-6EEK	9	Wainwright GmbH	pre-m	2	
270	termination	1418 N	BB6935	Weinschel	pre-m	2	
271	termination	1418 N	BE6384	Weinschel	pre-m	2	
272	attenuator (20 dB) 50 W	Model 47	BF6239	Weinschel	pre-m	2	
273	attenuator (10 dB) 100 W	Model 48	BF9229	Weinschel	pre-m	2	
274	attenuator (10 dB) 50 W	Model 47 (10 dB) 50 W	BG0321	Weinschel	pre-m	2	
275	DC-Block	Model 7003 (N)	C5129	Weinschel	pre-m	2	
276	DC-Block	Model 7006 (SMA)	C7061	Weinschel	pre-m	2	
279	power divider	1515 (SMA)	LH855	Weinschel	pre-m	2	
298	Univ. Radio Communication Tester	CMU 200	832221/091	Rohde & Schwarz	pre-m	3	
300	AC LISN (50 Ohm/50µH, 1-phase)	ESH3-Z5	892 239/020	Rohde & Schwarz	12 M	-	17.05.2019
301	attenuator (20 dB) 50W, 18GHz	47-20-33	AW0272	Lucas Weinschel	pre-m	2	
302	horn antenna 40 GHz (Meas 1)	BBHA9170	155	Schwarzbeck	36 M	-	14.03.2020
303	horn antenna 40 GHz (Subst 1)	BBHA9170	156	Schwarzbeck	36 M	-	20.03.2020
331	Climatic Test Chamber -40/+180 Grad	HC 4055	43146	Heraeus Vötsch	24 M	-	30.10.2018
341	Digital Multimeter	Fluke 112	81650455	Fluke	24 M	-	30.05.2020
342	Digital Multimeter	Voltcraft M-4660A	IB 255466	Voltcraft	24 M	-	17.05.2019
347	laboratory site	radio lab.	-	-	-	5	

Ref.-No.	Equipment	Type	Serial-No.	Manufacturer	Interval of calibration	Remark	Cal due
348	laboratory site	EMI conducted	-	-	-	5	
354	DC - Power Supply 40A	NGPE 40/40	448	Rohde & Schwarz	pre-m	2	
357	power sensor	NRV-Z1	861761/002	Rohde & Schwarz	24 M	-	24.05.2019
371	Bluetooth Tester	CBT32	100153	R&S	36 M	-	30.05.2019
373	Single-Line V-Network (50 Ohm/5µH)	ESH3-Z6	100535	Rohde & Schwarz	12 M	-	17.05.2019
377	EMI Test Receiver	ESCS 30	100160	Rohde & Schwarz	12 M	-	30.05.2019
389	Digital Multimeter	Keithley 2000	0583926	Keithley	pre-m	-	
392	Radio Communication Tester	MT8820A	6K00000788	Anritsu	12 M	-	30.06.2019
405	Thermo-/Hygrometer	OPUS 10 THI	126.0604.0003.3.3.3.22	LUFFT Mess u. Regeltechnik GmbH	24 M	-	30.03.2019
431	Model 7405	Near-Field Probe Set	9305-2457	EMCO	-	4	
436	Univ. Radio Communication Tester	CMU 200	103083	Rohde & Schwarz	12 M	-	06.03.2019
439	UltraLog-Antenna	HL 562	100248	Rohde & Schwarz	36 M	-	10.03.2020
454	Oscilloscope	HM 205-3	9210 P 29661	Hameg	-	4	
456	DC-Power supply 0-5 A	EA 3013 S	207810	Elektro Automatik	pre-m	2	
459	DC -Power supply 0-5 A , 0-32 V	EA-PS 2032-50	910722	Elektro Automatik	pre-m	2	
460	Univ. Radio Communication Tester	CMU 200	108901	Rohde & Schwarz	12 M	-	30.05.2019
463	Universal source	HP3245A	2831A03472	Agilent	-	4	
466	Digital Multimeter	Fluke 112	89210157	Fluke USA	24 M	-	30.05.2020
467	Digital Multimeter	Fluke 112	89680306	Fluke USA	36 M	-	30.05.2019
468	Digital Multimeter	Fluke 112	90090455	Fluke USA	36 M	-	30.04.2021
477	ReRadiating GPS-System	AS-47	-	Automotive Cons. Fink	-	3	
480	power meter (Fula)	NRVS	838392/031	Rohde & Schwarz	24 M	-	16.05.2019
482	filter matrix	Filter matrix SAR 1	-	CETECOM (Brl)	-	1d	
487	System CTC NSA-Verification SAR-EMI	System EMI field (SAR) NSA	-	ETS Lindgren / CETECOM	24 M	-	31.03.2019
489	EMI Test Receiver	ESU40	1000-30	Rohde & Schwarz	12 M	-	30.06.2019
502	band reject filter	WRCG 1709/1786-1699/1796-	SN 9	Wainwright	pre-m	2	
503	band reject filter	WRCG 824/849-814/859-60/10SS	SN 5	Wainwright	pre-m	2	
517	relais switch matrix	HF Relais Box Keithley System	SE 04	Keithley	pre-m	2	
523	Digital Multimeter	L4411A	MY46000154	Agilent	24 M	-	18.05.2019
529	6 dB Broadband resistive power divider	Model 1515	LH 855	Weinschel	pre-m	2	
530	10 dB Broadband resistive power divider	R 416110000	LOT 9828	-	pre-m	2	
546	Univ. Radio Communication Tester	CMU 200	106436	R&S	12 M	-	30.07.2019
547	Univ. Radio Communication Tester	CMU 200	835390/014	Rohde & Schwarz	12 M	-	30.07.2019
549	Log.Per-Antenna	HL025	1000060	Rohde & Schwarz	36/12 M	-	31.07.2021
550	System CTC S-VSWR Verification SAR-EMI	System EMI Field SAR S-VSWR	-	ETS Lindgren/CETECOM	24 M	-	30.03.2019
558	System CTC FAR S-VSWR	System CTC FAR S-VSWR	-	CTC	24 M	-	08.08.2019
574	Biconilog Hybrid Antenna	BTA-L	980026L	Frankonia	36/12 M	-	31.03.2019
584	Spectrum Analyzer	FSU 8	100248	Rohde & Schwarz	pre-m	-	
594	Wideband Radio Communication Tester	CMW 500	101757	Rohde & Schwarz	12 M	-	30.05.2019
597	Univ. Radio Communication Tester	CMU 200	100347	Rohde & Schwarz	pre-m	-	
600	power meter	NRVD (Reserve)	834501/018	Rohde & Schwarz	24 M	-	17.05.2019
601	medium-sensitivity diode sensor	NRV-Z5 (Reserve)	8435323/003	Rohde & Schwarz	24 M	-	15.05.2019
602	peak power sensor	NRV-Z32 (Reserve)	835080	Rohde & Schwarz	24 M	-	
611	DC power supply	E3632A	KR 75305854	Agilent	pre-m	2	
612	DC power supply	E3632A	MY 40001321	Agilent	pre-m	2	
613	Attenuator	R416120000 20dB 10W	Lot. 9828	Radiall	pre-m	2	
616	Digitalmultimeter	Fluke 177	88900339	Fluke	24 M	-	30.05.2020
617	Power Splitter/Combiner	ZFSC-2-2-S+	S F987001108	Mini Circuits	-	2	
618	Power Splitter/Combiner	50PD-634	600994	JFW Industries USA	-	2	
619	Power Splitter/Combiner	50PD-634	600995	JFW Industries, USA	-	3	
620	EMI Test Receiver	ESU 26	100362	Rohde-Schwarz	12 M	-	30.05.2019
621	Step Attenuator 0-139 dB	RSP	100017	Rohde & Schwarz	pre-m	2	

Ref.-No.	Equipment	Type	Serial-No.	Manufacturer	Interval of calibration	Remark	Cal due
625	Generic Test Load USB	Generic Test Load USB	-	CETECOM	-	2	
627	data logger	OPUS 1	201.0999.9302.6.4.1.43	G. Lufft GmbH	24 M	-	30.03.2019
634	Spectrum Analyzer	FSM (HF-Unit)	826188/010	Rohde & Schwarz	pre-m	2	
637	High Speed HDMI with Ethernet 1m	HDMI cable with Ethernet 1m	-	KogiLink	-	2	
638	HDMI Kabel with Ethernet 1,5 m flach	HDMI cable with Ethernet 1,5m	-	Reichelt	-	2	
640	HDMI cable 2m rund	HDMI cable 2m rund	-	Reichelt	-	2	
641	HDMI cable with Ethernet	Certified HDMI cable with	-	PureLink	-	2	
642	Wideband Radio Communication Tester	CMW 500	126089	Rohde&Schwarz	24 M	-	24.05.2019
644	Amplifier	ZX60-2534M+	SN865701299	Mini-Circuits	-	-	
670	Univ. Radio Communication Tester	CMU 200	106833	Rohde & Schwarz	24 M	-	30.05.2020
671	DC-power supply 0-5 A	EA-3013S	-	Elektro Automatik	pre-m	2	
678	Power Meter	NRP	101638	Rohde&Schwarz	pre-m	-	
683	Spectrum Analyzer	FSU 26	200571	Rohde & Schwarz	12 M	-	30.05.2019
686	Field Analyzer	EHP-200A	160WX30702	Narda Safety Test Solutions	24 M	-	29.03.2019
687	Signal Generator	SMF 100A	102073	Rohde&Schwarz	12 M	-	30.05.2019
688	Pre Amp	JS-18004000-40-8P	1750117	Miteq	pre-m	-	
690	Spectrum Analyzer	FSU	100302/026	Rohde&Schwarz	24 M	-	16.05.2019
691	OSP120 Base Unit	OSP120	106833	Rohde & Schwarz	12 M	-	30.05.2019
692	Bluetooth Tester	CBT 32	100236	Rohde & Schwarz	36 M	-	29.05.2020
693	TS8997	CTC-Radio Lab 1_TS8997	-	Rohde&Schwarz	12 M	5	30.05.2019
697	Power Splitter	ZN4PD-642W-S+	165001445	Mini-Circuits	-	2	
701	CMW500 wide. Radio Comm.	CMW500	158150	Rohde & Schwarz	12 M	-	30.07.2019
703	INNCO Antennen Mast	MA 4010-KT080-XPET-ZSS3	MA4170-KT100-XPET-ZSS3	INNCO	pre-m	-	
704	INNCON Controllor	CO 3000-4port	CO3000/933/38410516/L	INNCO Systems GmbH	pre-m	-	
711	Harmonic Mixer 90 GHz - 140GHz	RPG FS-Z140	101004	RPG	36 M	-	22.02.2020
712	Harmonic Mixer 75 GHz - 110GHz	FS-Z110	101468	Rohde & Schwarz	36 M	-	22.02.2020
713	Harmonic Mixer, 50 GHz - 75GHz	FS-Z75	101022	Rohde & Schwarz	36 M	-	22.05.2020
714	Signal Analyzer 67GHz	FSW67	104023	Rohde & Schwarz	24 M	-	28.02.2020
715	Harmonic Mixer, 140 GHz - 220GHz	FS-Z220	101009	RPG Radiometer Physics	36 M	-	03.08.2020
716	Harmonic Mixer 220 GHz to 325 GHZ	FS-Z325	101005	RPG Radiometer Physics	36 M	-	13.02.2020
747	Spectrum Analyzer	FSU 26	200152	Rohde & Schwarz	12 M	-	30.05.2019
748	Pickett-Potter Horn Antenna	FH-PP 4060	010001	Radiometer Physics	36 M	-	
749	Pickett-potter Horn Antenna	FH-PP 60-90	010003	Radiometer Physics	-	-	
750	Pickett-Potter Horn Antenna	FH-PP 140-220	010011	Radiometer Physics	-	-	
751	Digital Optical System	optoCAN-FD Transceiver	17-010416	mk-messtechnik GmbH	-	-	
752	Digital Optical System	optoCAN-FD Transceiver	17-010083	mk-messtechnik GmbH	-	-	
753	Digital Optical System	optoCAN-FD Transceiver	17-010084	mk-messtechnik GmbH	-	-	
754	Digital Optical System	optoCAN-FD Transceiver	17-010415	mk-messtechnik GmbH	-	-	
755	Digital Optical System	optoLAN-100-MAX Transceiver	17-010795	mk-messtechnik GmbH	-	-	
757	WIDEBAND RADIO COMMUNICATION	CMW500	163673	Rohde&Schwarz	12 M	-	20.07.2018
758	Signal Generator	SMU 200A	100754	Rohde & Schwarz	24 M	-	11.10.2019
780	Spectrum Analyzer	FSH3	101726	Rohde & Schwarz	24 M	-	19.07.2019
781	Power Supply	PS 2042-10 B	2815450369	Elektro-Automatik GmbH & Co.KG	-	-	
782	Power Supply	PS 2042-10 B	2815450348	lektro-Automatik GmbH & Co.KG	-	-	
783	Spectrum Analyzer	FSU 26	100414	Rohde & Schwarz	12 M	-	30.05.2019
784	Power Supply	NGSM 32/10	00196	Rohde & Schwarz	12 M	-	
785	RSP	RF Step Attenuator 0...139.9dB	860712/012	Rohde & Schwarz	12 M	-	
786	SAR Probe	ES3DV3	3340	Speag	36 M	-	14.02.2021
787	OSP	OSP B157WX	101264	Rohde & Schwarz	12 M	-	30.05.2019
788	Precision Omnidirectional Dipole	POD 618	6182558/Q	Seibersdorf Laboratories	36 M	-	30.06.2021
789	Precision Omnidirectional Dipole	POD 16	162496/Q	Seibersdorf Laboratories	36 M	-	30.06.2021

8.1.3. Legend

Note / remarks		Calibrated during system calibration:
	1a	System CTC-SAR-EMS (Ref.-No. 442)
	1b	System-CTC-EMS-Conducted (Ref.-No. 335)
	1c	System CTC-FAR-EMI-RSE (Ref.-No. 443)
	1d	System CTC-SAR-EMI (Ref.-No. 441)
	1e	System CTC-OATS (EMI radiated) (Ref.-No. 337)
	1 f	System CTC-CTIA-OTA (Ref.-No. 420)
	1 g	System CTC-FAR-EMS (Ref.-No. 444)
	2	Calibration or equipment check immediately before measurement
	3	Regulatory maintained equipment for functional check or support purpose
	4	Ancillary equipment without calibration e.g. mechanical equipment or monitoring equipment
	5	Test System

Interval of calibration	12 M	12 month
	24 M	24 month
	36 M	36 month
	24/12 M	Calibration every 24 months. between this every 12 months internal validation
	36/12 M	Calibration every 36 months. between this every 12 months internal validation
	Pre-m	Check before starting the measurement
	-	Without calibration

9. Versions of test reports (change history)

Version	Applied changes	Date of release
--	Initial release	2018-08-23
C01	SW Status updated	2018-09-07
C01	FVIN updated, Module report reference	2018-09-25