







**PARTIAL TEST REPORT**  
 No.: 18-1-0050701T03a\_C01

According to:  
**FCC Regulations**  
 Part 15.205  
 Part 15.209  
 Part 15.247  
**ISED-Regulations**  
 RSS-Gen, Issue 4  
 RSS-247, Issue 2

for

**Datalogic S.r.l.**  
**Joya Touch A6**  
 Type: A00AN04HLXGT0AN

**FCC ID: U4GJTADG**  
**ISED ID: 3862E-JTADG**  
**HVIN JTADG GUN**  
**HVIN JTADG HH**

Laboratory Accreditation and Listings		
 <p>Accredited EMC-Test Laboratory</p>	 <p>Industry Canada            Reg. No.: 3462D-1            Reg. No.: 3462D-2            Reg. No.: 3462D-3</p>	 <p>Voluntary Controls for Electromagnetic Emissions            Reg. No.:            R-4552, C-20009,            T-20006, G-20013</p>
 <p>AUTHORIZED RF LABORATORY</p>	 <p>Lab Code: 20011130-00</p>	 <p>MRA US-EU 0003</p>
accredited according to DIN EN ISO/IEC 17025		
<p align="center"><b>CETECOM GmbH</b>            Laboratory Radio Communications &amp; Electromagnetic Compatibility            Im Teelbruch 116 • 45219 Essen • Germany            Registered in Essen, Germany, Reg. No.: HRB Essen 8984            Tel.: + 49 (0) 20 54 / 95 19-954 • Fax: + 49 (0) 20 54 / 95 19-964            E-mail: info@cetecom.com • Internet: www.cetecom.com</p>		

## Table of contents

<b>1. SUMMARY OF TEST RESULTS.....</b>	<b>3</b>
1.1. Tests measurement overview according of US CFR Title 47, Subpart 15C and ISED (RSS) Standard: .....	3
1.2. Attestation:.....	5
<b>2. ADMINISTRATIVE DATA .....</b>	<b>6</b>
2.1. Identification of the testing laboratory .....	6
2.2. Test location .....	6
2.3. Organizational items .....	6
2.4. Applicant’s details .....	6
2.5. Manufacturer’s details .....	6
<b>3. EQUIPMENT UNDER TEST (EUT).....</b>	<b>7</b>
3.1. Technical data of main EUT declared by applicant .....	7
3.2. IEEE 802.11 overview: modulation and data rates .....	8
3.3. EUT: Type, S/N etc. and short descriptions used in this test report .....	8
3.4. Auxiliary Equipment (AE): Type, S/N etc. and short descriptions .....	9
3.5. EUT set-ups .....	9
3.6. EUT operating modes .....	9
3.7. Worst Case Selection .....	10
<b>4. DESCRIPTION OF TEST SYSTEM SET-UP’S .....</b>	<b>11</b>
4.1. Test system set-up for conducted measurements on antenna port .....	11
4.2. Test system set-up for radiated magnetic field measurements below 30 MHz .....	13
4.3. Test system set-up for radiated electric field measurement 30 MHz to 1 GHz .....	14
4.4. Test system set-up for radiated electric field measurement above 1 GHz .....	15
<b>5. MEASUREMENT RESULTS.....</b>	<b>16</b>
5.1. Duty-Cycle.....	16
5.2. RF-Parameter – RF Power conducted.....	17
5.3. General Limit - Radiated field strength emissions below 30 MHz.....	19
5.4. General Limit - Radiated field strength emissions, 30 MHz - 1 GHz.....	21
5.5. General Limit - Radiated emissions, above 1 GHz.....	23
5.6. RF-Parameter - Radiated Band Edge compliance measurements .....	25
5.7. Measurement uncertainties .....	27
<b>6. ABBREVIATIONS USED IN THIS REPORT .....</b>	<b>28</b>
<b>7. ACCREDITATION DETAILS OF CETECOM’S LABORATORIES AND TEST SITES .....</b>	<b>28</b>
<b>8. INSTRUMENTS AND ANCILLARY .....</b>	<b>29</b>
8.1. Used equipment “CTC” .....	29
<b>9. VERSIONS OF TEST REPORTS (CHANGE HISTORY) .....</b>	<b>33</b>

### Table of Annex

Annex No.	Contents	Reference Description	Total Pages
<b>Annex 1</b>	Test results	<b>CETECOM_TR18-1-0050701T03-A1</b>	38
<b>Annex 2</b>	External photographs of EUT	<b>JTA6DG External Pictures</b>	11
<b>Annex 3</b>	Internal photographs of EUT	<b>Internal Pictures JOYA TOUCH A6 DG</b>	8
<b>Annex 4</b>	Test set-up photographs	<b>CETECOM_TR18-1-0050701T02-A4</b>	7

The listed attachments are an integral part of this report.

## 1. Summary of test results

The test results apply exclusively to the test samples as presented in this Report. The CETECOM GmbH does not assume responsibility for any conclusions and generalizations taken in conjunction with other specimens or samples of the type of the item presented to tests.

**The test results apply exclusively to the test samples as presented in this Report. The CETECOM GmbH does not assume responsibility for any conclusions and generalizations taken in conjunction with other specimens or samples of the type of the item presented to tests. Also we refer on special conditions which the applicant should fulfill according §2.927 to §2.948, special focus regarding modification of the equipment and availability of sample equipment for market surveillance tests.**

The presented Equipment Under Test (in this report, hereinafter referred as EUT) supports radiofrequency technologies with WLAN technology and operating frequency range at 2.412 to 2.462 GHz according to IEE 802.11 b/g/n. Other implemented wireless technologies were not considered within this test report.

Following test cases have been performed to show compliance with valid RSS-Gen, Issue 4 & RSS-247, Issue 2 of the ISED Regulations and Part 15.205/15.209/15.247 of the FCC CFR Title 47 Rules, Edition 4<sup>th</sup> November 2016.

### 1.1. Tests measurement overview according of US CFR Title 47, Subpart 15C and ISED (RSS) Standard:

Test cases	Port	References & Limits			EUT set-up	EUT operating mode	Result
		FCC Standard	RSS Standard	Test Limit			
TX-Mode							
Timing of transmitter (pulsed operation)	Antenna Terminal or enclosure	§15.35	RSS-Gen, Issue 4, Chapter 6.10	--	--	--	for Information only
6 dB bandwidth	Antenna terminal (conducted)	§15.247(a)(2)	RSS-247, Issue 2 Chapter 5.2 b	≥ 500 kHz for DTS systems	--	--	Remark *1)
99% occupied bandwidth	Antenna terminal (conducted)	2.1049(h)	RSS-Gen, Issue 5, Chapter 6.7	99% Power bandwidth	--	--	Remark *1)
Transmitter Peak output power	Antenna terminal (conducted)	§15.247(b)(3)	RSS-247, Issue 2 Chapter 5.1 d	1 Watt Peak	--	--	Pass
Transmitter Peak output power radiated	Enclosure + Inter-connecting cables (radiated)	§15.247(b)(4)	RSS-247, Issue 2 Chapter 5.1 d	< 4 Watt (EIRP) for antenna with directional gain less 6dBi	--	--	Remark *1)
Out-Of-Band RF-emissions Band-Edge emissions	Antenna terminal (conducted)	§15.247 (d)	RSS-Gen, Issue 4, Chapter 8.9	20 dBc or RSS-Gen, Issue 4, Table 4 limits	--	--	Remark *1)

Power spectral density	Antenna terminal (conducted)	§15.247(e)	RSS-247, Issue 2 Chapter 5.2 b	8dBm in any 3 kHz band	--	--	Remark *1)
Transmitter frequency stability	Antenna terminal (conducted)	--	RSS-Gen, Issue 4, Chapter 8.11	Occupied bandwidth entirely outside restricted bands and prohibited TV bands	--	--	Remark *1)
General field strength emissions + restricted bands	Enclosure + Inter-connecting cables (radiated)	§15.247 (d) §15.205 §15.209	RSS-247, Issue 2, Chapter 5.5  RSS-Gen: Issue 4: §8.9 Table 4+5+6	Emissions in restricted bands must meet the general field-strength radiated limits	1	1	Pass
AC-Power Lines  Conducted Emissions	AC-Power lines	§15.207	RSS-Gen, Issue 4: Chapter 8.8 Table 3	FCC §15.107 class B limits §15.207 limits  ISED: Table 3, Chapter 8.8	--	--	Remark *2)

Remark 1) Refer SIMT 1502 (FCC ID: UDV-20170406) Report No. ER/2017/50040, issue date Jul 07,2017

Remark 2): **Not tested in this report. Refer separate report 18-1-0050701T05a**

RF-Exposure Evaluation (separation distance user to RF-radiating element greater 20cm)						
Test cases	Port	References & Limits		EUT set-up	EUT operating mode	Result
		FCC Standard	Test Limit			
Radio frequency radiation exposure requirements	Cabinet + Inter-connecting cables (radiated)	§1.1310(b) §2.1091 §2.1093	SAR-Limits FCC: 1.1310(b)	--	--	Refer separate report:  CETECOM_TR18-1-0050701T01a
			RF-Field Strength Limits: FCC: "general population/uncontrolled" environment Table 1	1	1	

Remark: --

Test report 18-1-0050701T03a\_C01 dated 2018-09-25 replace test report 18-1-0050701T03, dated 2018-09-07. The replaced report gets invalid herewith.

### 1.2. Attestation:

I declare that all measurements were performed by me or under my supervision and that all measurements have been performed and are correct to my best knowledge and belief to Code of Federal Regulations. All requirements as shown in above table are met in accordance with enumerated standards.

.....  
Dipl.-Ing. Niels Jeß  
Responsible for test section

.....  
B. Sc. Mohamed Ahmed  
Responsible for test report

## 2. Administrative Data

### 2.1. Identification of the testing laboratory

Company name:	CETECOM GmbH
Address:	Im Teelbruch 116 45219 Essen - Kettwig Germany
Responsible for testing laboratory:	Dipl.-Ing. Niels Jeß

### 2.2. Test location

#### 2.2.1. Test laboratory "CTC"

Company name:	see chapter 2.1. Identification of the testing laboratory
---------------	---

### 2.3. Organizational items

Responsible for test report:	B.Sc. Mohamed Ahmed
Responsible for project:	Dipl.-Ing. Ninovic Perez
Receipt of EUT:	2018-03-20
Date(s) of test:	2018-04-27 to 2018-05-20
Date of report:	2018-09-25
-----	
Version of template:	13.02

### 2.4. Applicant's details

Applicant's name:	Datalogic S.r.l.
Address:	Via S. Vitalino 13 40012 Lippo di Calderara di Reno (BO)  Italy
Contact person:	Mr.Francesco Rossi

### 2.5. Manufacturer's details

Manufacturer's name:	please see applicant's details
Address:	please see applicant's details

### 3. Equipment under test (EUT)

#### 3.1. Technical data of main EUT declared by applicant

<b>EUT Model</b>	<b>Joya Touch A6</b>		
<b>EUT Model Type</b>	<b>A6</b>		
<b>EUT Type</b>	<b>Portable Mobile Computer</b>		
<b>EUT Applications</b>	<b>Shopping Applications &amp; General Purpose Mobile Computer</b>		
<b>FCC ID</b>	<b>U4GJTADG</b>		
<b>Additional Information: Integrated Module</b>			
<b>Integrated Module</b>	<b>SIMT 1502</b>		
<b>Module Certification FCC ID</b>	<b>UDV-20170406</b>		
<b>Number of Integrated Modules</b>	<b>1</b>		
<b>Additional Information : Supported Technologies</b>			
<b>Technology</b>	<b>Modes</b>	<b>Frequency Range</b>	<b>Remarks</b>
<b>WLAN 2.4 GHz</b>	<b>WLAN 802.11b/g/n(HT20)</b>	<b>2412 MHz – 2462 MHz</b>	refer chapter 3.2
<b>Bluetooth LE</b>	<b>Bluetooth Low Energy</b>	<b>2402 MHz – 2480 MHz</b>	not tested under this report
<b>Bluetooth FHSS</b>	<b>Bluetooth BR-EDR</b>	<b>2402 MHz – 2480 MHz</b>	not tested under this report
<b>WLAN 5 GHz</b>	<b>WLAN 802.11a/n(HT20)/n(HT40)</b>	<b>5150 MHz –5850 MHz</b>	not tested under this report

### 3.2. IEEE 802.11 overview: modulation and data rates

The modulations and data rates defined for 802.11 b/g/n transmitters are identified in the table below. Also it shows which operational mode is possible for the device under test (EUT) according applicant's information.

802.11b-Mode (DSSS System)		
Data rate [Mbps]	Modulation type	Supported by EUT
1	DBPSK (Differential binary phase shift keying)	YES
2	DQPSK (Differential quadrature phase shift keying)	YES
5.5 / 11	CCK/PBCC (8-chip complementary code keying)	YES
22	ERP-PBCC (Packet binary convolutional coding)	NO

802.11g-Mode (OFDM system)		
Brutto data rate [Mbps]	Modulation type of subcarriers	Supported by EUT
6 / 9	BPSK	YES
12 / 18	QPSK	YES
24 / 36	16-QAM	YES
48 / 54	64-QAM	YES

Remark: 52 sub-carriers which can be modulated at different data-rates.

802.11n-Mode (OFDM)		
Brutto data rate [Mbps]	Modulation type	Supported by EUT
7.2/14.4/21.7/28.9/43.3/57.8/65/72.2 Mbps	HT20 (MCS0..MCS7)	YES
14.444/28.889/43.333/57.778/86.667/115.556/130/144.444 Mbps	HT20 (MCS8..MCS7)	NO
15/30/45/60/90/120/135/150 Mbps	HT40 (MCS0..MCS7)	YES
30/60/90/120/180/240/270/300 Mbps	HT40 (MCS8..MCS15)	NO

Comments: For additional details please refer to

### 3.3. EUT: Type, S/N etc. and short descriptions used in this test report

Short description*)	EUT	Type	S/N serial number	HW hardware status	SW software status
EUT A	Jova Touch A6 Gun Variant	A00AN04HLXGT 0AN	G18D03796	Beta	02.12
EUT B	Jova Touch A6 Gun Variant	A00AN04HLXGT 0AN	G18D03791	Beta	02.12
EUT C	Jova Touch A6 (Handheld Variant)	A00AN04HLXHT 0AN	G18D03794	Beta	02.12

\*) EUT short description is used to simplify the identification of the EUT in this test report.



### 3.4. Auxiliary Equipment (AE): Type, S/N etc. and short descriptions

AE short description *)	Auxiliary Equipment	Type	S/N serial number	HW hardware status	SW software status
AE 1	--	--	--	--	--

\*) AE short description is used to simplify the identification of the auxiliary equipment in this test report.

### 3.5. EUT set-ups

EUT set-up no. *)	Combination of EUT and AE	Remarks
set. 1	EUT A	Used for radiated tests
set. 2	EUT B	Used for conducted tests
set. 3	EUT C	Used for radiated tests

EUT set-up no. is used to simplify the identification of the EUT set-up in this test report.

### 3.6. EUT operating modes

EUT operating mode no. *1)	Description of operating modes	Additional information
op. 1	TX-Mode	With help of special test Software (CTA-WIFI Test Tool, Version: 1.0.0) a continuous traffic mode in duty cycle was set-up *2)

\*1) EUT operating mode no. is used to simplify the test report.

\*2) ) Please refer to document “20180613\_FCC\_JTA\_Test-Tools\_Quick\_Start\_Instructions” dated 2018-06-13 for additional information regarding operating mode setup and output power levels.

The Test Software CTA-WIFI Test Tool was implemented on the EUT

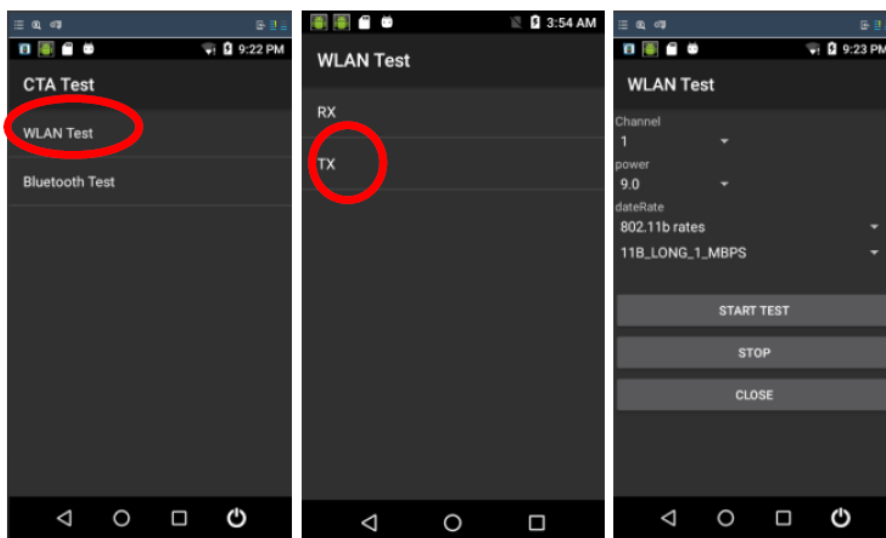

Wifi Settings for each mode and Channel:

Sub-band	Mode	Bit rate	dateRate	dateRate/2	power		
					CH1	CH2-10	CH11
2.4 GHz	802.11b	1M	802.11b rates	11B_LONG_1_MBPS	16		
		2M	802.11b rates	11B_LONG_2_MBPS	16		
		5.5M	802.11b rates	11B_LONG_5_5_MBPS	16		
		11M	802.11b rates	11B_LONG_11_MBPS	16		
	802.11g	54Mbps	802.11 a/g rates	11A_54_MBPS	11	11	9,5
		48Mbps	802.11 a/g rates	11A_48_MBPS	12,5	13	9,5
		36Mbps	802.11 a/g rates	11A_36_MBPS	12,5	15	9,5
		24Mbps	802.11 a/g rates	11A_24_MBPS	12,5	15	9,5
		18Mbps	802.11 a/g rates	11A_18_MBPS	12,5	15	9,5
		12Mbps	802.11 a/g rates	11A_12_MBPS	12,5	15	9,5
		9Mbps	802.11 a/g rates	11A_9_MBPS	12,5	15	9,5
		6Mbps	802.11 a/g rates	11A_6_MBPS	12,5	15	9,5
802.11n	MCS7	MCS (20MHz)	MCS_72_2_MBPS	10,5	10,5	9,5	
	MCS6	MCS (20MHz)	MCS_58_5_MBPS	12	12	9,5	
	MCS5	MCS (20MHz)	MCS_52_MBPS	12,5	13,5	9,5	
	MCS4	MCS (20MHz)	MCS_39_MBPS	12,5	15	9,5	
	MCS3	MCS (20MHz)	MCS_26_MBPS	12,5	15	9,5	
	MCS2	MCS (20MHz)	MCS_19_5_MBPS	12,5	15	9,5	
	MCS1	MCS (20MHz)	MCS_13_MBPS	12,5	15	9,5	
	MCS0	MCS (20MHz)	MCS_6_5_MBPS	12,5	15	9,5	

### 3.7. Worst Case Selection

For the Handheld Variant only spot checks were tested.

## 4. Description of test system set-up's

### 4.1. Test system set-up for conducted measurements on antenna port Conducted Set-up W1

#### W-LAN conducted RF-Setup 1 (W1 Set-up)

**General description:**

The EUT's RF-signal is coupled out by a suitable antenna coupling connector (1). The signal is first attenuated (2) then connected to the power meter (3) for conducted power measurements. The specific attenuation loss is determined prior to the measurement within a set-up attenuation measurement. These are then taken into account by correcting the measurement readings.

**Schematic:**

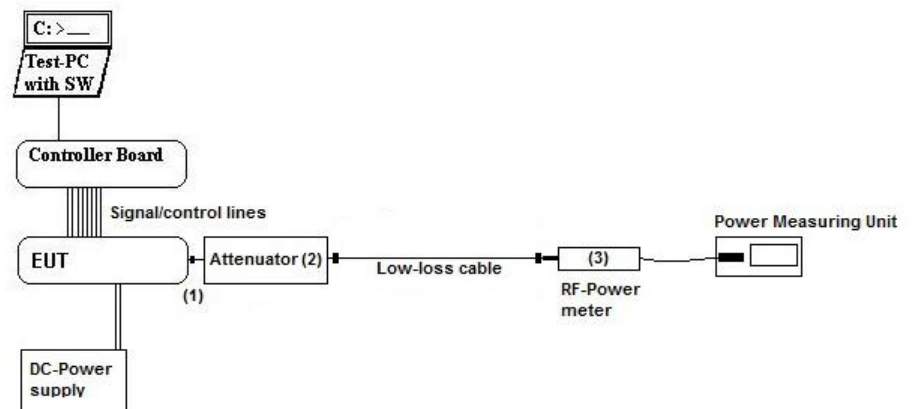

**Testing method:**

ANSI C63.10:2013, KDB 558074 D01 DTS Meas.Guidance v04

**Used Equipment**

Passive Elements	Test Equipment	Remark:
<input checked="" type="checkbox"/> 20 dB Attenuator	<input checked="" type="checkbox"/> Power Meter	See List of equipment under each test case and chapter 6 for calibration info
<input checked="" type="checkbox"/> Low loss RF-cables	<input checked="" type="checkbox"/> DC-Power Supply	
<input checked="" type="checkbox"/>	<input checked="" type="checkbox"/> Spectrum-Analyser	

**Measurement uncertainty**

See chapter 5.10

**Conducted Set-up W2**

**W-LAN conducted RF-Setup 2 (W2 Set-up)**

**General description:** The EUT's RF-signal is coupled out by a suitable antenna coupling connector (1). The signal is first attenuated (2) then connected to spectrum-analyzer (4) for RF-conducted measurements. The specific attenuation loss is determined prior to the measurement within a set-up attenuation measurement. These are then taken into account by correcting the measurement readings of the spectrum-analyzer.

**Schematic:**

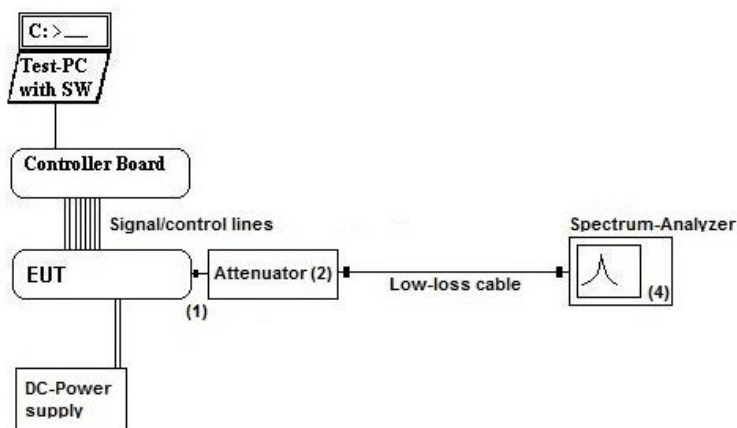

**Testing method:** ANSI C63.10:2013, KDB 558074 D01 DTS Meas.Guidance v04

Used Equipment	Passive Elements	Test Equipment	Remark:
	<input checked="" type="checkbox"/> 20 dB Attenuator	<input checked="" type="checkbox"/> Power Meter	See List of equipment under each test case and chapter 6 for calibration info
	<input checked="" type="checkbox"/> Low loss RF-cables	<input checked="" type="checkbox"/> DC-Power Supply	
		<input checked="" type="checkbox"/> Spectrum-Analyser	

**Measurement uncertainty** See chapter 5.10

## 4.2. Test system set-up for radiated magnetic field measurements below 30 MHz

**Specification:** ANSI C63.10-2013 chapter 6.4 (§6.4.4.2)

**General Description:** Evaluating the radiated field emissions are done first by an exploratory emission measurement and a final measurement for most critical frequencies determined.

The loop antenna was placed at 1 m height above ground plane and 3 m measurement distance from set-up for investigations. Because of reduced measurement distance, correction data were applied, as stated in chapter “General Limit - Radiated field strength emissions below 30 MHz”. The tests are performed in the semi anechoic room recognized by the regulatory commission.

**Schematic:**

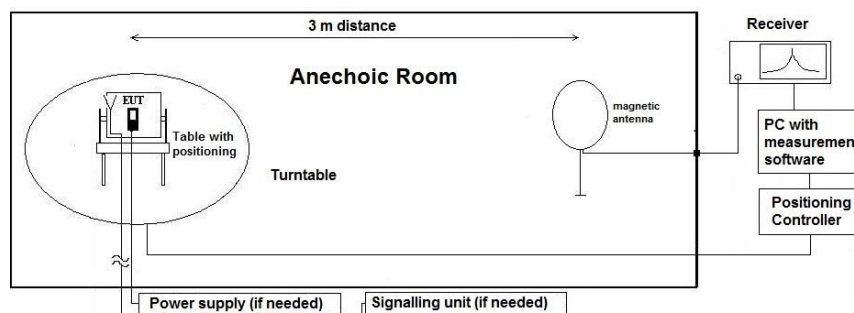

**Testing method:**

### Exploratory, preliminary measurement

The EUT and its associated accessories are placed on a non-conductive position manipulator (tipping device) of 0.8 m height which is placed on the turntable. By rotating the turntable (step 90°, range 0° to 360°) and the EUT itself either on 3-orthogonal axis (portable equipment) or 2-orthogonal axis (defined operational position of EUT), the emission spectrum was recorded. The loop antenna was moved at least to 2-perpendicular axes (antenna vector in direction of EUT and parallel to EUT) in order to maximize the emissions. The results are documented in a diagram. Critical frequencies (low margin to limit) are saved within a data reduction table for further investigations. If various operating modes are supported, further investigations are made to find the worst-case. Also the interconnection cables and equipment position were varied in order to maximize the emissions.

### Final measurement on critical frequencies

Based on the exploratory measurements, the most critical frequencies are re-measured by maintaining the EUT's worst-case operation mode, cable position, etc.

First a frequency zoom around the critical frequency is done to locate the frequency more precisely. After this step, for all identified critical frequencies, the maximum peak was determined.

Following parameters were varied: the turntable angle continuously in the range 0 to 360 degree, the EUT itself either over 3-orthogonal axis (not defined usage position) or 2-orthogonal axis (defined usage position).

On the determined worst-case position, a final measurement with necessary bandwidth and detector according standard has been carried out.

**Formula:**

$$E_C = E_R + AF + C_L + D_F - G_A$$

$$M = L_T - E_C$$

AF = Antenna factor

C<sub>L</sub> = Cable loss

D<sub>F</sub> = Distance correction factor

E<sub>C</sub> = Electrical field – corrected value

E<sub>R</sub> = Receiver reading

G<sub>A</sub> = Gain of pre-amplifier (if used)

L<sub>T</sub> = Limit

M = Margin

All units are dB-units, positive margin means value is below limit.

**Distance correction:**

**Reference for applied correction (extrapolating) factors due to reduced measurement distance:**

ANSI C63.10:2013, §6.4.4.2 - Equations (2) + (3) + (4)

### 4.3. Test system set-up for radiated electric field measurement 30 MHz to 1 GHz

**Specification:** ANSI C63.4-2014 chapter 8.2.3, ANSI C63.10-2013 chapter 6.5

**General Description:** Evaluating the field emissions have to be done first by an exploratory emissions measurement and a final measurement for most critical frequencies. The tests are performed in a NSA-compliant semi anechoic room (SAR) recognized by the regulatory commissions.

**Schematic:**

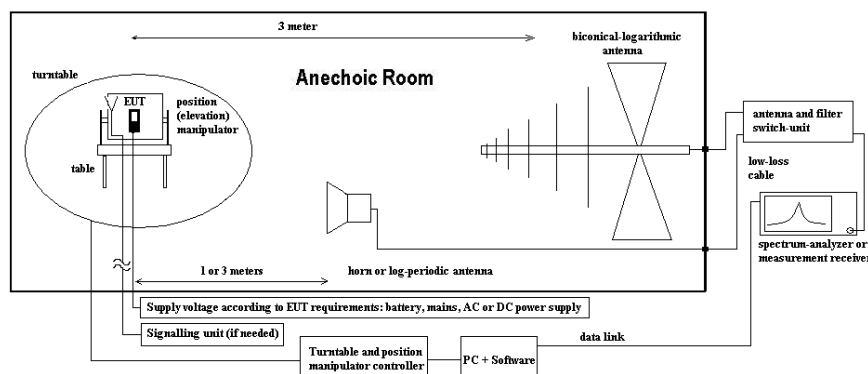

**Testing method:**

**Exploratory, preliminary measurements**

The EUT and its associated accessories are placed on a non-conductive position manipulator (tipping device) of 0.8 m height which is placed on the turntable. By rotating the turntable (range 0° to 360°, step 90°) and the EUT itself either on 3-orthogonal axis (portable equipment) or 2-orthogonal axis (defined operational position of EUT) the emission spectrum and its characteristics was recorded with an EMI-receiver, broadband antenna and software.

Measurement antenna: horizontal and vertical, heights: 1,0 m and 1,82 m as worst-case determined by an exploratory emission measurements. The results are documented in a diagram. Critical frequencies (low margin to limit) are saved within a table for further investigations. If various operating modes are supported, further investigations are made to find the worst-case of them. Also the interconnection cables and equipment position were varied in order to maximize the emissions.

**Final measurement on critical frequencies**

Based on the exploratory measurements, the most critical frequencies are re-measured by maintaining the EUT's worst-case operation mode, cable position, etc. either on 10m OATS or 3m semi-anechoic room.

First a frequency zoom around the critical frequency is done to locate the frequency more precisely. After this step, for all identified critical frequencies, the maximum peak was determined.

Following parameters were varied: the turntable angle continuously in the range 0 to 360 degree, the EUT itself either over 3-orthogonal axis (not defined usage position) or 2-orthogonal axis (defined usage position). The measurement antenna height between 1 m and 4 m.

On the determined worst-case position, a final measurement with necessary bandwidth and detector according standard has been carried out.

**Formula:**

$$E_C = E_R + AF + C_L + D_F - G_A \quad (1)$$

$$M = L_T - E_C \quad (2)$$

- AF = Antenna factor
- C<sub>L</sub> = Cable loss
- D<sub>F</sub> = Distance correction factor (if used)
- E<sub>C</sub> = Electrical field – corrected value
- E<sub>R</sub> = Receiver reading
- G<sub>A</sub> = Gain of pre-amplifier (if used)
- L<sub>T</sub> = Limit
- M = Margin

All units are dB-units, positive margin means value is below limit.

#### 4.4. Test system set-up for radiated electric field measurement above 1 GHz

**Specification:** ANSI C63.4-2014 chapter 8.3, ANSI C63.10-2013 chapter 6.6.3.3 & 6.6.4

**General Description:** Evaluating the emissions have to be done first by an exploratory emissions measurement and a final measurement for most critical frequencies. The tests are performed in a CISPR 16-1-4:2010 compliant fully anechoic room (FAR) recognized by the regulatory commission. The measurement distance was set to 3 meter for frequencies up to 18 GHz and 2 meter above 18 GHz. A logarithmic periodic antenna is used for the frequency range 30 MHz to 1 GHz. Horn antennas are used for frequency range 1 GHz to 40 GHz. The EUT is aligned within 3 dB beam width of the measurement antenna with three orthogonal axis measurements on the EUT.

**Schematic:**

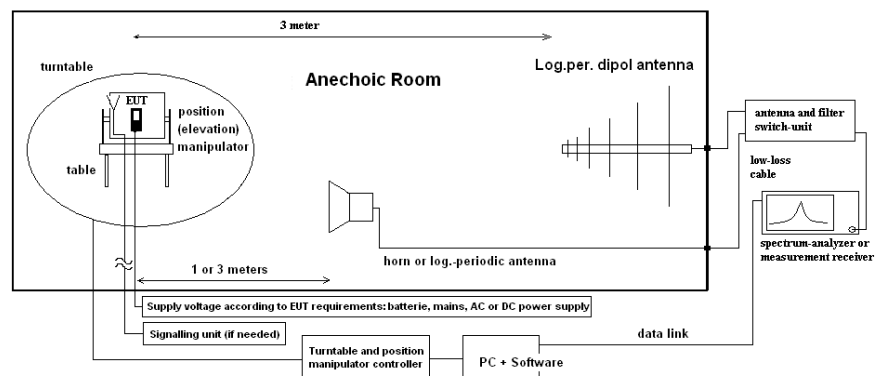

**Testing method:**

##### Exploratory, preliminary measurements

The EUT and its associated accessories are placed on a non-conductive position manipulator (tipping device) of 1.55 m height which is placed on the turntable. By rotating the turntable (range 0° to 360°, step 15°) and the EUT itself either on 3-orthogonal axis (portable equipment) or 2-orthogonal axis (defined operational position of EUT) the emission spectrum and its characteristics was recorded with an EMI-receiver, broadband antenna and software.

The measurements are performed in horizontal and vertical polarization of the measurement antennas. The results are documented in a diagram. Critical frequencies (low margin to limit) are saved within a table for further investigations. If various operating modes are supported, further investigations are made to find the worst-case of them. Also the interconnection cables and equipment position were varied in order to maximize the emissions.

##### Final measurement on critical frequencies

Based on the exploratory measurements, the most critical frequencies are re-measured by maintaining the EUT's worst-case operation mode, cable position, etc.

First a frequency zoom around the critical frequency is done to locate the frequency more precisely. After this step, for all identified critical frequencies, the maximum peak was determined. Following parameters were varied: the turntable angle continuously in the range 0 to 360 degree, the EUT itself over 3-orthogonal axis and the height for EUT with large dimensions.

On the determined worst-case position, a final measurement with necessary bandwidth and detector according standard has been carried out. On the determined worst-case position, a final measurement with necessary bandwidth and detector according standard has been carried out.

**Formula:**

$$E_C = E_R + AF + C_L + D_F - G_A \quad (1)$$

$$M = L_T - E_C \quad (2)$$

$E_C$  = Electrical field – corrected value

$E_R$  = Receiver reading

$M$  = Margin

$L_T$  = Limit

$AF$  = Antenna factor

$C_L$  = Cable loss

$D_F$  = Distance correction factor (if used)

$G_A$  = Gain of pre-amplifier (if used)

All units are dB-units, positive margin means value is below limit.

## 5. Measurement results

### 5.1. Duty-Cycle

#### 5.1.1. Test location and equipment (for reference numbers please see chapter 'List of test equipment')

Ambient Climatic conditions			Temperature: (22±2)°C			Rel. humidity: (45±15)%		
Test Site	<input type="checkbox"/> 441 EMI SAR	<input type="checkbox"/> 348 EMI cond.	<input type="checkbox"/> 443 EMI FAR	<input checked="" type="checkbox"/> 347 Radio.lab.	<input type="checkbox"/> 337 OATS	<input type="checkbox"/>	<input type="checkbox"/>	<input type="checkbox"/>
Equipment	<input type="checkbox"/> 331 HC 4055	<input type="checkbox"/>	<input type="checkbox"/>	<input type="checkbox"/>	<input type="checkbox"/>	<input type="checkbox"/>	<input type="checkbox"/>	<input type="checkbox"/>
Spectr. Analys.	<input checked="" type="checkbox"/> 683 FSU26	<input type="checkbox"/> 120 FSEM	<input type="checkbox"/> 264 FSEK	<input checked="" type="checkbox"/> 693 TS8997	<input type="checkbox"/>	<input type="checkbox"/>	<input type="checkbox"/>	<input type="checkbox"/>
Power Meter	<input type="checkbox"/> 262 NRV-S	<input type="checkbox"/> 266 NRV-Z31	<input type="checkbox"/> 265 NRV-Z33	<input type="checkbox"/> 261 NRV-Z55	<input type="checkbox"/> 356 NRV-Z1	<input type="checkbox"/>	<input type="checkbox"/>	<input type="checkbox"/>
Multimeter	<input type="checkbox"/> 341 Fluke 112	<input type="checkbox"/>	<input type="checkbox"/>	<input type="checkbox"/>	<input type="checkbox"/>	<input type="checkbox"/>	<input type="checkbox"/>	<input type="checkbox"/>
DC Power	<input type="checkbox"/> 086 LNG50-10	<input type="checkbox"/> 087 EA3013	<input type="checkbox"/> 354 NGPE 40	<input type="checkbox"/> 349 car battery	<input type="checkbox"/> 350 Car battery	<input type="checkbox"/>	<input type="checkbox"/>	<input type="checkbox"/> 463 HP3245A
Supply Voltage	<input type="checkbox"/> 230 V 50 Hz via public mains			<input checked="" type="checkbox"/> 4.20 V DC (fully charged internal battery)				
Otherwise	<input checked="" type="checkbox"/> 530 Attenuator 10dB	<input checked="" type="checkbox"/> K4 Cable						

Method of measurement:  conducted  
 radiated

**A special firmware program is used for test purposes. In contrast to normal operating mode a higher duty-cycle is set in order to facilitate the measurements. This is maximized at the extent possible.**

The necessary duty-cycle correction factor is determined on nominal conditions on 1 channel for all sub-bands. It is assumed that no noticeable changes occur when tested on other channels or climatic conditions.

Calculated with following formulas:

Duty cycle:	$x = \frac{T_{x_{on}}}{T_{x_{on}} + T_{x_{off}}}$	Duty cycle factor [dB]:	$10 \log\left(\frac{1}{x}\right)$
-------------	---	-------------------------	-----------------------------------

Results:

Set-up No.:	1
Op. Mode:	1

DUTY-CYCLE Measurement								
WLAN 2.4 GHz	Marker 1	Marker 2	Marker 3	TX ON Marker 2 - Marker 1	TX OFF Marker 3 - Marker 2	Duty Cycle	Correction- Factor: 100log(1/DC)	Plot No.
Data Rate	ms	ms	ms	ms	ms	(%)	(dB)	(Remark 1)
WLAN 2.4 GHz b-Mode   B.W. 20 MHz   SISO   Ch 6 (2437 MHz)								
5.5Mbit	1,609744	3,249167	3,460705	1,63942	0,21154	88,57	0,53	b-mode PWR Level 15
WLAN 2.4 GHz g-Mode   B.W. 20 MHz   SISO   Ch 6 (2437 MHz)								
24Mbit	0,572115	0,925481	1,124038	0,35337	0,19856	64,02	1,94	g-mode PWR Level 15
WLAN 2.4 GHz n-Mode   B.W. 20 MHz   SISO   Ch 6 (2437 MHz)								
MCS6	0,065224	0,308846	0,507708	0,24362	0,19886	55,06	2,59	n-mode PWR Level 15

Remark 1: For further details please refer → Annex 1: Test results - CETECOM\_TR18-1-0050701T02a-A1

- The results were corrected in order to evaluate for worst-case result each time when average values are necessary for example average radiated emissions or similar
- No correction necessary: Duty-Cycle > 98%



## 5.2. RF-Parameter – RF Power conducted

### 5.2.1. Test location and equipment (for reference numbers please see chapter 'List of test equipment')

test location	<input checked="" type="checkbox"/> CETECOM Essen (Chapter. 2.2.1)	<input type="checkbox"/> 443 System CTC-FAR-EMI-	<input type="checkbox"/> Please see Chapter. 2.2.3
test site	<input type="checkbox"/> 441 EMI SAR	<input type="checkbox"/> 487 SAR NSA	<input type="checkbox"/> 337 OATS
receiver	<input type="checkbox"/> 377 ESCS30	<input type="checkbox"/> 001 ESS	<input checked="" type="checkbox"/> 347 Radio.lab.
otherwise	<input type="checkbox"/> 600 NRVD	<input type="checkbox"/> 357 NRV-Z1	<input type="checkbox"/> 489 ESU 40
spectr. analys.	<input type="checkbox"/> 215 FSU	<input type="checkbox"/> 120 FSEM	<input type="checkbox"/> 620 ESU 26
power supply	<input type="checkbox"/> 456 EA 3013A	<input type="checkbox"/> 457 EA 3013A	<input type="checkbox"/> 693 TS8997
otherwise	<input checked="" type="checkbox"/> 613 20 dB Attenuator	<input type="checkbox"/> 248 6 dB Attenuator	<input type="checkbox"/> 264 FSEK
Supply voltage	<input type="checkbox"/> 230 V 50 Hz via public mains	<input checked="" type="checkbox"/> 4.20 V DC (fully charged internal battery)	<input type="checkbox"/> 494 AG6632A
			<input type="checkbox"/> 354 NGPE 40
			<input type="checkbox"/> 529 Power divider
			<input type="checkbox"/> - cable OTA20
			<input type="checkbox"/> 530 10dB Atten
			<input type="checkbox"/> K5 Cable

### 5.2.2. Reference

<b>FCC</b>	<input checked="" type="checkbox"/> §15.247(b) (3) + KDB 558074 D01 DTS Meas Guidance v04
<b>ISED</b>	<input checked="" type="checkbox"/> RSS-247, Chapter 5.4(4)
<b>ANSI</b>	<input checked="" type="checkbox"/> ANSI 63.10:2013
<b>Specification</b>	<i>For systems using digital modulation in the 902-928 MHz, 2400-2483.5 MHz, and 5725-5850 MHz bands: 1 Watt. As an alternative to a peak power measurement, compliance with the one Watt limit can be based on a measurement of the maximum conducted output power. Maximum Conducted Output Power is defined as the total transmit power delivered to all antennas and antenna elements averaged across all symbols in the signalling alphabet when the transmitter is operating at its maximum power control level. Power must be summed across all antennas and antenna elements. The average must not include any time intervals during which the transmitter is off or is transmitting at a reduced power level. If multiple modes of operation are possible (e.g., alternative modulation methods), the maximum conducted output power is the highest total transmit power occurring in any mode.</i>

### 5.2.3. Antenna characteristics:

- directional gain < 6 dBi (Applicants declaration)
- directional gain > 6 dBi (measured / applicant's declaration) -> conducted power reduction necessary

### 5.2.4. EUT settings:

The EUT was instructed to send with maximum power (if adjustable) according applicants instructions.

### 5.2.5. Measurement method and analyzer settings:

The measurement was performed in non-hopping transmission mode with the carrier set to lowest/middle and highest channel.

#### MEASUREMENT METHOD/ SPECTRUM-ANALYZER SETTINGS:

Measurement Method <sup>1)</sup>	§15.247(b) (3) Maximum Peak	1.) <input checked="" type="checkbox"/> PK1-Method (§5.2.1.1): RBW > 6dB-bandwidth of the signal, ANSI 63.10: 2009, chapter 6.10.2.1a
	§15.247(b) (3) Maximum Average	2.) <input type="checkbox"/> PK2-Method (§5.2.1.2): Channel integration method (ANSI 63.10:2013 ) 3.) <input type="checkbox"/> PK1-Method (§9.1.2 KDB): Peak Power Meter Method 4.) <input type="checkbox"/> AVG1 - power averaging over EBW + integrated band power measurement 5.) <input type="checkbox"/> AVG2 - trace averaging over EBW + integrated band power measurement 6.) <input type="checkbox"/> RMS power meter method
	MIMO	7.) <input type="checkbox"/> Method as described in Chapter 3.8 was used for measurements on two available RF-Antenna ports.
Center Frequency	Nominal channel frequency	
Span	30% higher than the EBW measured before	
Resolution Bandwidth (RBW)	20MHz	
Video Bandwidth (VBW)	30MHz	
Sweep time	coupled	
Detector	Peak, Max hold mode for method PK1/PK2 or RMS and trace average for method AVG1/AVG2	
Sweep Mode	Repetitive mode, allow trace to stabilize	
Analyzer-Mode	<input type="checkbox"/> normal <input type="checkbox"/> activated channel integration method with limits set to the EBW of the signal	

Remark 1: guidance 558074 D01 measurement DTS guidance v04

### 5.2.6. RESULTS

#### APPLICANT'S DECLARED ANTENNA CHARACTERISTICS:

- Directional Gain < 6 dBi (measured: difference between measured conducted and radiated eirp. power)
- Directional Gain > 6 dBi (measured / applicant's declaration) -> conducted power reduction necessary

- Applicant's declared Maximum Directional ANT1 Peak Gain : 2.14 dBi

WLAN 2.4GHz b-Mode		Channel No. (Frequency MHz)			b-Mode	Power Units
Data rate	Modulation	1 (2412)	6 (2437)	11 (2462)	Maximum Value	
1Mbit		17,80	17,37	17,67	18,07	dBm
2Mbit		17,81	17,56	17,57		
5.5Mbit		18,02	17,54	17,73		
11Mbit		17,94	17,77	18,07		
17.77WLAN 2.4 GHz Conducted Peak Power Limits					30.0	dBm
WLAN 2.4GHz g-Mode		Channel No. (Frequency MHz)			g-Mode	Power Units
Data rate	Modulation	1 (2412)	6 (2437)	11 (2462)	Maximum Value	
6Mbit		20,69	20,75	18,95	20,96	dBm
9Mbit		20,90	20,76	18,90		
12Mbit		20,85	20,69	18,84		
18Mbit		20,91	20,92	18,98		
24Mbit		20,78	20,94	19,28		
36Mbit		20,39	20,93	19,05		
48Mbit		20,75	20,66	19,25		
54Mbit		20,08	20,96	18,87		
WLAN 2.4 GHz Conducted Peak Power Limits						
WLAN 2.4GHz n-Mode HT20		Channel No. (Frequency MHz)			n-Mode HT20	Power Units
Data rate	Modulation	1 (2412)	6 (2437)	11 (2462)	Maximum Value	
MCS0 -6.5Mbps	BPSK	20,35	20,66	19,44	20,73	dBm
MCS1 - 13Mbps	QPSK	20,51	20,72	18,95		
MCS2 - 19.5Mbps	QPSK	20,64	20,67	19,06		
MCS3 - 26Mbps	QAM16	20,49	20,73	18,90		
MCS4 -39Mbps	QAM16	20,56	20,71	18,92		
MCS5 - 52Mbps	QAM64	20,34	20,56	19,09		
MCS6 - 58.5Mbps	QAM64	20,14	20,19	19,15		
MCS7 - 65Mbps	QAM64	19,36	19,39	19,35		
WLAN 2.4 GHz Conducted Peak Power Limits						

### 5.3. General Limit - Radiated field strength emissions below 30 MHz

#### 5.3.1. Test location and equipment

test location	<input checked="" type="checkbox"/> CETECOM Essen (Chapter. 2.2.1)	<input type="checkbox"/> Please see Chapter. 2.2.2	<input type="checkbox"/> Please see Chapter. 2.2.3
test site	<input checked="" type="checkbox"/> 441 EMI SAR	<input type="checkbox"/> 487 SAR NSA	<input type="checkbox"/> 347 Radio.lab.
receiver	<input type="checkbox"/> 377 ESCS30	<input checked="" type="checkbox"/> 001 ESS	<input type="checkbox"/>
spectr. analys.	<input type="checkbox"/> 584 FSU	<input type="checkbox"/> 120 FSEM	<input type="checkbox"/> 264 FSEK
antenna	<input type="checkbox"/> 574 BTA-L	<input type="checkbox"/> 133 EMCO3115	<input type="checkbox"/> 302 BBHA9170
signaling	<input type="checkbox"/> 392 MT8820A	<input type="checkbox"/> 371 CBT32	<input type="checkbox"/> 547 CMU
otherwise	<input type="checkbox"/> 400 FTC40x15E	<input type="checkbox"/> 401 FTC40x15E	<input type="checkbox"/> 110 USB LWL
DC power	<input type="checkbox"/> 671 EA-3013S	<input checked="" type="checkbox"/> 457 EA 3013A	<input type="checkbox"/> 459 EA 2032-50
line voltage	<input checked="" type="checkbox"/> 3.77V DC fully charged battery	<input type="checkbox"/> 060 120 V 60 Hz	via PAS 5000

#### 5.3.2. Requirements

<b>FCC</b>	Part 15, Subpart C, §15.205 & §15.209			
<b>ISED</b>	RSS-Gen: Issue 5: §8.9 Table 6			
<b>ANSI</b>	C63.10-2013			
Frequency [MHz]	Field strength limit		Distance [m]	Remarks
	[µV/m]	[dBµV/m]		
0.009 – 0.490	2400/f (kHz)	67.6 – 20Log(f) (kHz)	300	Correction factor used due to measurement distance of 3 m
0.490 – 1.705	24000/f (kHz)	87.6 – 20Log(f) (kHz)	30	Correction factor used due to measurement distance of 3 m
1.705 – 30	30	29.5	30	Correction factor used due to measurement distance of 3 m

#### 5.3.3. Test condition and test set-up

Signal link to test system (if used):	<input type="checkbox"/> air link	<input type="checkbox"/> cable connection	<input type="checkbox"/> none
EUT-grounding	<input checked="" type="checkbox"/> none	<input type="checkbox"/> with power supply	<input type="checkbox"/> additional connection
Equipment set up	<input checked="" type="checkbox"/> table top		<input type="checkbox"/> floor standing
Climatic conditions	Temperature: (22±3°C)		Rel. humidity: (40±20)%
EMI-Receiver or Analyzer Settings	Scan data	<input checked="" type="checkbox"/> 9 – 150 kHz RBW/VBW = 200 Hz Scan step = 80 Hz <input checked="" type="checkbox"/> 150 kHz – 30 MHz RBW/VBW = 9 kHz Scan step = 4 kHz <input type="checkbox"/> other:	
	Scan-Mode Detector Mode: Sweep-Time	<input checked="" type="checkbox"/> 6 dB EMI-Receiver Mode <input type="checkbox"/> 3dB Spectrum analyser Mode Peak (pre-measurement) and Quasi-PK/Average (final if applicable) Repetitive-Scan, max-hold Coupled – calibrated display if continuous signal otherwise adapted to EUT’s individual transmission duty-cycle	
General measurement procedures	Please see chapter “Test system set-up radiated magnetic field measurements below 30 MHz”		

#### 5.3.4. Measurement Results

The results are presented below in summary form only. For more information please consult the diagrams included in annex 1.

Table of measurement results:

Diagram No.	Carrier Channel		Frequency range	Set-up no.	OP-mode no.	Remark	Used detector			Result
	Range	No.					PK	AV	QP	
2.01a/b	Low	1	9 kHz - 30 MHz	1	1	n20 – mode   MCS6	<input checked="" type="checkbox"/>	<input type="checkbox"/>	<input type="checkbox"/>	Pass
2.02a/b	Mid	6	9 kHz - 30 MHz	1	1	g – mode   24Mbit	<input checked="" type="checkbox"/>	<input type="checkbox"/>	<input type="checkbox"/>	Pass
2.03a/b	high	11	9 kHz - 30 MHz	1	1	b – mode   5.5Mbit	<input checked="" type="checkbox"/>	<input type="checkbox"/>	<input type="checkbox"/>	Pass
2.034	high	11	9 kHz - 30 MHz	3	1	b – mode   11Mbit	<input checked="" type="checkbox"/>	<input type="checkbox"/>	<input type="checkbox"/>	Pass

### 5.3.5. Correction factors due to reduced meas. distance (f< 30 MHz)

The used correction factors when the measurement distance is reduced compared to regulatory measurement distance, are calculated according Extrapolation formulas valid for EUT's with maximum dimension of 0.625xLambda. Formula 2+3+4 as presented in ANSI C63.10, Chapter 6.4.4 are used for the calculations of proper extrapolation factors.

Frequency Range	f [kHz/MHz]	Lambda [m]	Far-Field Point [m]	Distance Limit accord. 15.209 [m]	1st Condition (d <sub>meas</sub> < D <sub>near-field</sub> )	2te Condition (Limit distance bigger d <sub>near-field</sub> )	Distance Correction accord. Formula
kHz	9,00E+03	33333,33	5305,17	300	fulfilled	not fulfilled	-80,00
	1,00E+04	30000,00	4774,65		fulfilled	not fulfilled	-80,00
	2,00E+04	15000,00	2387,33		fulfilled	not fulfilled	-80,00
	3,00E+04	10000,00	1591,55		fulfilled	not fulfilled	-80,00
	4,00E+04	7500,00	1193,66		fulfilled	not fulfilled	-80,00
	5,00E+04	6000,00	954,93		fulfilled	not fulfilled	-80,00
	6,00E+04	5000,00	795,78		fulfilled	not fulfilled	-80,00
	7,00E+04	4285,71	682,09		fulfilled	not fulfilled	-80,00
	8,00E+04	3750,00	596,83		fulfilled	not fulfilled	-80,00
	9,00E+04	3333,33	530,52		fulfilled	not fulfilled	-80,00
	1,00E+05	3000,00	477,47		fulfilled	not fulfilled	-80,00
	1,25E+05	2400,00	381,97		fulfilled	not fulfilled	-80,00
	2,00E+05	1500,00	238,73		fulfilled	fulfilled	-78,02
	3,00E+05	1000,00	159,16		fulfilled	fulfilled	-74,49
	4,00E+05	750,00	119,37		fulfilled	fulfilled	-72,00
	4,90E+05	612,24	97,44		fulfilled	fulfilled	-70,23
	5,00E+05	600,00	95,49		fulfilled	not fulfilled	-40,00
	6,00E+05	500,00	79,58		fulfilled	not fulfilled	-40,00
7,00E+05	428,57	68,21	fulfilled	not fulfilled	-40,00		
8,00E+05	375,00	59,68	fulfilled	not fulfilled	-40,00		
9,00E+05	333,33	53,05	fulfilled	not fulfilled	-40,00		
MHz	1,00	300,00	47,75	30	fulfilled	not fulfilled	-40,00
	1,59	188,50	30,00		fulfilled	not fulfilled	-40,00
	2,00	150,00	23,87		fulfilled	fulfilled	-38,02
	3,00	100,00	15,92		fulfilled	fulfilled	-34,49
	4,00	75,00	11,94		fulfilled	fulfilled	-32,00
	5,00	60,00	9,55		fulfilled	fulfilled	-30,06
	6,00	50,00	7,96		fulfilled	fulfilled	-28,47
	7,00	42,86	6,82		fulfilled	fulfilled	-27,13
	8,00	37,50	5,97		fulfilled	fulfilled	-25,97
	9,00	33,33	5,31		fulfilled	fulfilled	-24,95
	10,00	30,00	4,77		fulfilled	fulfilled	-24,04
	10,60	28,30	4,50		fulfilled	fulfilled	-23,53
	11,00	27,27	4,34		fulfilled	fulfilled	-23,21
	12,00	25,00	3,98		fulfilled	fulfilled	-22,45
	13,56	22,12	3,52		fulfilled	fulfilled	-21,39
	15,00	20,00	3,18		fulfilled	fulfilled	-20,51
	15,92	18,85	3,00		fulfilled	fulfilled	-20,00
	17,00	17,65	2,81		not fulfilled	fulfilled	-20,00
	18,00	16,67	2,65		not fulfilled	fulfilled	-20,00
	20,00	15,00	2,39		not fulfilled	fulfilled	-20,00
	21,00	14,29	2,27		not fulfilled	fulfilled	-20,00
23,00	13,04	2,08	not fulfilled	fulfilled	-20,00		
25,00	12,00	1,91	not fulfilled	fulfilled	-20,00		
27,00	11,11	1,77	not fulfilled	fulfilled	-20,00		
29,00	10,34	1,65	not fulfilled	fulfilled	-20,00		
30,00	10,00	1,59	not fulfilled	fulfilled	-20,00		

## 5.4. General Limit - Radiated field strength emissions, 30 MHz - 1 GHz

### 5.4.1. Test location and equipment

test location	<input checked="" type="checkbox"/> CETECOM Essen (Chapter. 2.2.1)	<input type="checkbox"/> Please see Chapter. 2.2.2		<input type="checkbox"/> Please see Chapter. 2.2.3	
test site	<input checked="" type="checkbox"/> 441 EMI SAR	<input checked="" type="checkbox"/> 487 SAR NSA			
receiver	<input type="checkbox"/> 377 ESCS30	<input checked="" type="checkbox"/> 001 ESS	<input type="checkbox"/> 489 ESU 40	<input type="checkbox"/> 620 ESU 26	
spectr. analys.	<input type="checkbox"/> 584 FSU	<input type="checkbox"/> 120 FSEM	<input type="checkbox"/> 264 FSEK		
antenna	<input checked="" type="checkbox"/> 574 BTA-L	<input type="checkbox"/> 133 EMCO3115	<input type="checkbox"/> 302 BBHA9170	<input type="checkbox"/> 289 CBL 6141	<input type="checkbox"/> 030 HFH-Z2 <input type="checkbox"/> 477 GPS
signaling	<input type="checkbox"/> 392 MT8820A	<input type="checkbox"/> 371 CBT32	<input type="checkbox"/> 547 CMU	<input type="checkbox"/> 594 CMW	
otherwise	<input type="checkbox"/> 400 FTC40x15E	<input type="checkbox"/> 401 FTC40x15E	<input type="checkbox"/> 110 USB LWL	<input checked="" type="checkbox"/> 482 Filter Matrix	
DC power	<input type="checkbox"/> 456 EA 3013A	<input checked="" type="checkbox"/> 457 EA 3013A	<input type="checkbox"/> 459 EA 2032-50	<input type="checkbox"/> 268 EA- 3050	<input type="checkbox"/> 494 AG6632A <input type="checkbox"/> 498 NGPE
line voltage	<input checked="" type="checkbox"/> 3.77 V DC (fully charged internal battery)		<input type="checkbox"/> 060 120 V 60 Hz via PAS 5000		

### 5.4.2. Requirements/Limits

<b>FCC</b>		<input type="checkbox"/> Part 15 Subpart B, §15.109, class B <input checked="" type="checkbox"/> Part 15 Subpart C, §15.209 @ frequencies defined in §15.205	
<b>ISED (IC)</b>		<input checked="" type="checkbox"/> RSS-Gen., Issue 5, Chapter 8.9, Table 5+6+7 (licence-exempt radio apparatus) <input type="checkbox"/> RSS-Gen., Issue 5, Chapter 7.1.2, Table 2 (receiver) <input type="checkbox"/> ICES-003, Issue 6, Table 5 (Class B) <input checked="" type="checkbox"/> RSS-247, Issue 2, Chapter 5.5 <input type="checkbox"/> RSS-247, Issue 2, Chapter 6.2	
<b>ANSI</b>		<input type="checkbox"/> C63.4-2014 <input checked="" type="checkbox"/> C63.10-2013	
<b>Limit</b>	Frequency [MHz]	Radiated emissions limits, 3 meters	
		QUASI Peak [µV/m]	QUASI-Peak [dBµV/m]
	30 - 88	100	40.0
	88 - 216	150	43.5
	216 - 960	200	46.0
	above 960	500	54.0

### 5.4.3. Restricted bands of operation (FCC §15.205)

MHz	MHz	MHz	GHz
0.090-0.110	16.42-16.423	399.9-410	4.5-5.15
0.495-0.505	16.69475-16.69525	608-614	5.35-5.46
2.1735-2.1905	16.80425-16.80475	960-1240	7.25-7.75
4.125-4.128	25.5-25.67	1300-1427	8.025-8.5
4.20725-4.20775	37.5-38.25	1645.5-1646.5	9.3-9.5
6.215-6.218	73-74.6	1660-1710	10.6-12.7
6.26775-6.26825	74.8-75.2	1718.8-1722.2	13.25-13.4
6.31175-6.31225	108-121.94	2200-2300	14.47-14.5
8.291-8.294	123-138	2310-2390	15.35-16.2
8.362-8.366	149.9-150.05	2483.5-2500	17.7-21.4
8.37625-8.38675	156.52475-156.52525	2690-2900	22.01-23.12
8.41425-8.41475	156.7-156.9	3260-3267	23.6-24.0
12.29-12.293	162.0125-167.17	3332-3339	31.2-31.8
12.51975-12.52025	167.72-173.2	3345.8-3358	36.43-36.5
12.57675-12.57725	240-285	3600-4400	--
13.36-13.41	322-335.4	--	--

Remark: only spurious emissions are allowed within these frequency bands not exceeding the limits per §15.209

#### 5.4.4. Test condition and measurement test set-up

Signal link to test system (if used):		<input type="checkbox"/> air link	<input type="checkbox"/> cable connection	<input type="checkbox"/> none
EUT-grounding		<input type="checkbox"/> none	<input type="checkbox"/> with power supply	<input type="checkbox"/> additional connection
Equipment set up		<input checked="" type="checkbox"/> table top 0.8m height		<input type="checkbox"/> floor standing
Climatic conditions		Temperature: (22±3°C)		Rel. humidity: (40±20)%
EMI-Receiver (Analyzer) Settings	Scan frequency range:	<input checked="" type="checkbox"/> 30 – 1000 MHz <input type="checkbox"/> other:		
	Scan-Mode	<input checked="" type="checkbox"/> 6 dB EMI-Receiver Mode <input type="checkbox"/> 3 dB spectrum analyser mode		
	Detector	Peak / Quasi-peak		
	RBW/VBW	100 kHz/300 kHz		
	Mode:	Repetitive-Scan, max-hold		
Scan step	80 kHz			
Sweep-Time	Coupled – calibrated display if continuous tx-signal otherwise adapted to EUT's individual duty-cycle			
General measurement procedures		Please see chapter "Test system set-up for electric field measurement in the range 30 MHz to 1 GHz"		

#### 5.4.5. MEASUREMENT RESULTS

The results are presented below in summary form only. For more information please consult the diagrams included in annex 1.

Table of measurement results:

Diagram no.	Carrier Channel		Frequency range	Set-up no.	OP-mode no.	Remark	Used detector			Result
	Range	No.					PK	AV	QP	
2.01a/b	Low	1	30 MHz - 1 GHz	1	1	n20 – mode   MCS6	<input checked="" type="checkbox"/>	<input type="checkbox"/>	<input checked="" type="checkbox"/>	Pass
2.02a/b	Mid	6	30 MHz - 1 GHz	1	1	g – mode   24Mbit	<input checked="" type="checkbox"/>	<input type="checkbox"/>	<input checked="" type="checkbox"/>	Pass
2.03a/b	high	11	30 MHz - 1 GHz	1	1	b – mode   5.5Mbit	<input checked="" type="checkbox"/>	<input type="checkbox"/>	<input checked="" type="checkbox"/>	Pass
2.04	high	11	30 MHz - 1 GHz	3	1	b – mode   11 Mbit	<input checked="" type="checkbox"/>	<input type="checkbox"/>	<input checked="" type="checkbox"/>	Pass

Remark: --

## 5.5. General Limit - Radiated emissions, above 1 GHz

### 5.5.1. Test location and equipment FAR

test site	<input type="checkbox"/> 441 EMI SAR	<input type="checkbox"/> 348 EMI cond.	<input checked="" type="checkbox"/> 443 EMI FAR	<input type="checkbox"/> 347 Radio.lab.	<input type="checkbox"/> 337 OATS	<input type="checkbox"/>
spectr. analys.	<input type="checkbox"/> 584 FSU	<input type="checkbox"/> 120 FSEM	<input type="checkbox"/> 264 FSEK	<input checked="" type="checkbox"/> 489 ESU 40	<input type="checkbox"/>	<input type="checkbox"/>
antenna meas	<input type="checkbox"/> 574 BTA-L	<input type="checkbox"/> 289 CBL 6141	<input type="checkbox"/> 608 HL 562	<input checked="" type="checkbox"/> 549 HL025	<input checked="" type="checkbox"/> 302 BBHA9170	<input type="checkbox"/> 477 GPS
antenna meas	<input type="checkbox"/> 123 HUF-Z2	<input type="checkbox"/> 132 HUF-Z3	<input type="checkbox"/> 030 HFH-Z2	<input checked="" type="checkbox"/> 376 BBHA9120E		<input type="checkbox"/>
antenna subst	<input type="checkbox"/> 071 HUF-Z2	<input type="checkbox"/> 020 EMCO3115	<input type="checkbox"/> 063 LP 3146	<input type="checkbox"/> 303 BBHA9170	<input type="checkbox"/>	<input type="checkbox"/>
multimeter	<input type="checkbox"/> 341 Fluke 112	<input type="checkbox"/>	<input type="checkbox"/>	<input type="checkbox"/>	<input type="checkbox"/>	<input type="checkbox"/>
signaling	<input type="checkbox"/> 392 MT8820A	<input type="checkbox"/> 371 CBT32	<input type="checkbox"/> 547 CMU	<input type="checkbox"/> 594 CMW		
DCpower	<input type="checkbox"/> 086 LNG50-10	<input checked="" type="checkbox"/> 087 EA3013	<input type="checkbox"/> 354 NGPE 40	<input type="checkbox"/> 349 car battery	<input type="checkbox"/> 350 Car battery	<input type="checkbox"/>
line voltage	<input checked="" type="checkbox"/> 3.77 V DC (fully charged internal battery)		<input type="checkbox"/> 060 120 V 60 Hz via PAS 5000			

### 5.5.2. Requirements/Limits

<b>FCC</b>	<input type="checkbox"/> Part 15 Subpart B, §15.109 class B <input checked="" type="checkbox"/> Part 15 Subpart C, §15.209 for frequencies defined in §15.205 <input type="checkbox"/> Part 15 Subpart C, §15.407(b)(1)(2)(3)(4)			
<b>ISED</b>	<input checked="" type="checkbox"/> RSS-Gen., Issue 5, Chapter 8.9, Table 5+6+7 (transmitter licence exempt) <input type="checkbox"/> RSS-Gen., Issue 5, Chapter 7.3, Table 3 (receiver) <input type="checkbox"/> ICES-003, Issue 6, Chapter 6.2.2, Table 7 (class B) <input checked="" type="checkbox"/> RSS-247, Issue 2, Chapter 5.5 <input type="checkbox"/> RSS-247, Issue 2, Chapter 6.2			
<b>ANSI</b>	<input type="checkbox"/> C63.4-2014 <input checked="" type="checkbox"/> C63.10-2013			
Frequency [MHz]	Limits			
	AV [µV/m]	AV [dBµV/m]	Peak [µV/m]	Peak [dBµV/m]
above 1 GHz for frequencies as defined in §15.205 or RSS-Gen., Issue 9, §8.9 - Table 5	500	54.0	5000	74.0

### 5.5.3. Test condition and measurement test set-up

Signal link to test system (if used):	<input type="checkbox"/> air link	<input type="checkbox"/> cable connection	<input type="checkbox"/> none
EUT-grounding	<input checked="" type="checkbox"/> none	<input type="checkbox"/> with power supply	<input type="checkbox"/> additional connection
Equipment set up	<input checked="" type="checkbox"/> table top 1.5m height		<input type="checkbox"/> floor standing
Climatic conditions	Temperature: (22±3°C)		Rel. humidity: (40±20)%
Spectrum-Analyzer settings	Scan frequency range: <input checked="" type="checkbox"/> 1 – 18 GHz <input type="checkbox"/> 18 – 25 GHz <input type="checkbox"/> 18 – 40 GHz <input type="checkbox"/> other: <input checked="" type="checkbox"/> 6 dB EMI-Receiver Mode <input type="checkbox"/> 3 dB Spectrum analyser Mode Peak and Average 1 MHz / 3 MHz Mode: Repetitive-Scan, max-hold Scan step: 400 kHz Sweep-Time: Coupled – calibrated display if CW signal otherwise adapted to EUT's individual duty-cycle		
General measurement procedures	Please see chapter "Test system set-up for radiated electric field measurements above 1 GHz"		

### 5.5.4. Measurement Results

The results are presented below in summary form only. For more information please consult the diagrams included in annex 1.

Diagram no.	Carrier Channel		Frequency range	Set-up no.	OP-mode no.	Remark	Used detector			Result
	Range	No.					PK	AV	QP	
4.01	Low	1	1 GHz – 18 GHz	1	1	n20 – mode  MCS6	<input checked="" type="checkbox"/>	<input checked="" type="checkbox"/>	<input type="checkbox"/>	Pass
4.02	Mid	6	1 GHz – 18 GHz	1	1	g – mode   24Mbit	<input checked="" type="checkbox"/>	<input checked="" type="checkbox"/>	<input type="checkbox"/>	Pass
4.03	high	11	1 GHz – 18 GHz	1	1	b – mode   5.5Mbit	<input checked="" type="checkbox"/>	<input checked="" type="checkbox"/>	<input type="checkbox"/>	Pass
4.04	high	11	1 GHz – 18 GHz	3	1	b – mode   11 Mbit	<input checked="" type="checkbox"/>	<input checked="" type="checkbox"/>	<input type="checkbox"/>	Pass

Remark: for further details please see Annex 1 :18-1-0050701T03a-A1

Diagram no.	Carrier Channel		Frequency range	Set-up no.	OP-mode no.	Remark	Used detector			Result
	Range	No.					PK	AV	QP	
4.10c	Low	1	18 GHz – 25 GHz	1	1	n20 – mode  MCS6	<input checked="" type="checkbox"/>	<input checked="" type="checkbox"/>	<input type="checkbox"/>	Pass
4.11c	Mid	6	18 GHz – 25 GHz	1	1	g – mode   24Mbit	<input checked="" type="checkbox"/>	<input checked="" type="checkbox"/>	<input type="checkbox"/>	Pass
4.12c	high	11	18 GHz – 25 GHz	1	1	b – mode   5.5Mbit	<input checked="" type="checkbox"/>	<input checked="" type="checkbox"/>	<input type="checkbox"/>	Pass
4.03	high	11	18 GHz – 25 GHz	3	1	b – mode   11 Mbit	<input checked="" type="checkbox"/>	<input checked="" type="checkbox"/>	<input type="checkbox"/>	Pass

Remark: for further details please see Annex 1 :18-1-0050701T03a-A1



## 5.6. RF-Parameter - Radiated Band Edge compliance measurements

### 5.6.1. Test location and equipment FAR

test site	<input type="checkbox"/> 441 EMI SAR	<input type="checkbox"/> 348 EMI cond.	<input checked="" type="checkbox"/> 443 EMI FAR	<input type="checkbox"/> 347 Radio.lab.	<input type="checkbox"/> 337 OATS	<input type="checkbox"/>
spectr. analys.	<input type="checkbox"/> 584 FSU	<input type="checkbox"/> 120 FSEM	<input type="checkbox"/> 264 FSEK	<input checked="" type="checkbox"/> 489 ESU 40	<input type="checkbox"/>	<input type="checkbox"/>
antenna meas	<input type="checkbox"/> 574 BTA-L	<input type="checkbox"/> 289 CBL 6141	<input type="checkbox"/> 608 HL 562	<input checked="" type="checkbox"/> 549 HL025	<input type="checkbox"/> 302 BBHA9170	<input type="checkbox"/> 477 GPS
antenna meas	<input type="checkbox"/> 123 HUF-Z2	<input type="checkbox"/> 132 HUF-Z3	<input type="checkbox"/> 030 HFH-Z2	<input type="checkbox"/>	<input type="checkbox"/>	<input type="checkbox"/>
antenna subst	<input type="checkbox"/> 071 HUF-Z2	<input type="checkbox"/> 020 EMCO3115	<input type="checkbox"/> 063 LP 3146	<input type="checkbox"/> 303 BBHA9170	<input type="checkbox"/>	<input type="checkbox"/>
multimeter	<input type="checkbox"/> 341 Fluke 112	<input type="checkbox"/>	<input type="checkbox"/>	<input type="checkbox"/>	<input type="checkbox"/>	<input type="checkbox"/>
signaling	<input type="checkbox"/> 392 MT8820A	<input type="checkbox"/> 371 CBT32	<input type="checkbox"/> 547 CMU	<input type="checkbox"/> 594 CMW		
DC power	<input type="checkbox"/> 086 LNG50-10	<input checked="" type="checkbox"/> 087 EA3013	<input type="checkbox"/> 354 NGPE 40	<input type="checkbox"/> 349 car battery	<input type="checkbox"/> 350 Car battery	<input type="checkbox"/>
line voltage	<input checked="" type="checkbox"/> 3.77 V DC (fully charged internal battery)		<input type="checkbox"/> 060 120 V 60 Hz via PAS 5000			

### 5.6.2. Requirements/Limits

<b>FCC</b>	<input type="checkbox"/> Part 15 Subpart B, §15.109 class B <input checked="" type="checkbox"/> Part 15 subpart C, §15.209 @ frequencies defined in §15.205
<b>IC</b>	<input type="checkbox"/> RSS-210, Issue 8, Annex 8 <input checked="" type="checkbox"/> RSS-247, Issue 1, Chapter 5.5 <input checked="" type="checkbox"/> RSS-Gen: Issue 4: §8.9, Table 4+6
<b>ANSI</b>	<input type="checkbox"/> C63.4-2009 <input type="checkbox"/> C63.4-2014 <input type="checkbox"/> C63.10-2009 <input checked="" type="checkbox"/> C63.10-2013, Chapter 6.10.6

### 5.6.3. Test condition and measurement test set-up

Signal link to test system (if used):	<input type="checkbox"/> air link	<input type="checkbox"/> cable connection	<input checked="" type="checkbox"/> none
EUT-grounding	<input checked="" type="checkbox"/> none	<input type="checkbox"/> with power supply	<input type="checkbox"/> additional connection
Equipment set up	<input checked="" type="checkbox"/> table top 1.5m height		<input type="checkbox"/> floor standing
Climatic conditions	Temperature: (22±3°C)		Rel. humidity: (40±20)%
Spectrum-Analyzer settings	Scan frequency range: <input type="checkbox"/> 1 – 18 GHz <input type="checkbox"/> 18 – 25 GHz <input type="checkbox"/> 18 – 40 GHz <input checked="" type="checkbox"/> other: see diagrams Scan-Mode: <input type="checkbox"/> 6 dB EMI-Receiver Mode <input checked="" type="checkbox"/> 3 dB Spectrum analyzer Mode Detector: Peak and Average RBW/VBW: Left band-edge: 100kHz/300kHz Right band-edge: 1 MHz / 3 MHz Mode: Repetitive-Scan, max-hold Scan step: 40kHz or 400 kHz Sweep-Time: Coupled – calibrated display if CW signal otherwise adapted to EUT's individual duty-cycle		
General measurement procedures	Please see chapter "Test system set-up for radiated electric field measurements above 1 GHz" for general measurements procedures in anechoic chamber.		

### 5.6.4. Measurement Method

For uncritical results where a measurement resolution bandwidth of 1MHz can clearly show the compliance without influencing the results, a field strength measurement was performed to show compliance.

For critical results a Marker-Delta marker method was used for showing compliance to restricted bands. The method is according ANSI C63.10:2013, Chapter 6.10.6 "Marker-Delta method",. The method consists of three independent steps:

- 1. Step:** Prior to the measurement the fundamental radiated In-Band field strength was performed. The determined value is used as reference value.
- 2. Step:** Second step consist of finding the relative attenuation between the fundamental emission and the maximum local out-of-band emission (within 2 MHz range around the band edge either on the band-edge directly or some modulation product if the level is greater than that on the band-edge) when measured with lower resolution bandwidth.
- 3. Step:** The delta value recorded in step 2 will be subtracted from value recorded in step 1, thus giving the required field strength at the band-edge. This value must fulfil the requirements for radiated spurious emissions in restricted bands in FCC §15.205 with the general limits of FCC §15.209.

### 5.6.5. EUT settings

The EUT was instructed to send with maximum power (if adjustable) according to applicants instructions.

### 5.6.6. Results: for non-restricted bands near-by

#### 5.6.6.1. Non-restricted bands near-by - limits according FCC §15.407

Diagramm no.	Channel no.	Restricted band ?	Fundamental Value [dBuV/m]		Peak-Value at Band-Edge [dBuV/m]	Difference [dB]	Limit [dBc]	Margin [dB]	Verdict	Remark:
			Peak-Value	Average-Value						
9.03a	1	no	102,879	93,577	62,4	40,479	20	20,479	PASS	b-mode, 5,5 MBit
9.03b	1	no	98,515	88,053	67,017	31,498	20	11,498	PASS	g-mode, 24 Mbit
9.02a	1	no	98,44	88,94	67,6	30,84	20	10,84	PASS	n20-mode, MCS6
9.05	1	no	98,26	88,56	55,132	43,128	20	23,128	PASS	b-mode, 11MBit

#### 5.6.6.2. Restricted bands near-by

(§15.205 with limits accord. FCC §15.209)

Diagramm no.	Channel no.	Restricted band ?	Fundamental Value [dBuV/m]		Value at Band-Edge [dBuV/m]		Limits [dBuV/m]		Duty-Cycle Correction for AV-detector [dB]	Margin [dB]		Verdict	Remark:
			Peak-Value	Average-Value	Peak-Value	Average-Value	Peak-Value	Average-Value		Peak	Average		
9.03b	11	yes	106,61	100,708	63,37	51,259	74	54	0,53	10,63	2,211	PASS	b-mode, 5,5 MBit
9.14a	11	yes	105,011	92,595	68,308	51,62	74	54	1,94	5,692	0,44	PASS	g-mode, 24 Mbit PWR10.5
9.05a	11	yes	104,629	90,975	70,2	51,126	74	54	2,59	3,8	0,284	PASS	n20-mode, MCS6PWR9.5
9.06	11	yes	110,355	102,648	64,076	52,063	74	54	0,53	9,924	1,407	PASS	b-mode, 11MBit

Remark:

#### 5.6.7. Verdict: Pass

### 5.7. Measurement uncertainties

The reported uncertainties are calculated based on the standard uncertainty multiplied with the appropriate coverage factor **k**, such that a confidence level of approximately 95% is achieved.

For uncertainty determination, each component used in the concrete measurement set-up was taken in account and it's contribution to the overall uncertainty according to its statistical distribution calculated.

Following table shows expectable uncertainties for each measurement type performed.

RF-Measurement	Reference	Frequency range	Calculated uncertainty based on a confidence level of 95%						Remarks
Conducted emissions (U <sub>CISPR</sub> )	CISPR 16-2-1	9 kHz - 150 kHz	4.0 dB						-
		150 kHz - 30 MHz	3.6 dB						
Radiated emissions Enclosure	CISPR 16-2-3	30 MHz - 1 GHz	4.2 dB						E-Field
		1 GHz - 18 GHz	5.1 dB						
Disturbance power	CISPR 16-2-2	30 MHz - 300 MHz	-						-
Power Output radiated	-	30 MHz - 4 GHz	3.17 dB						Substitution method
Power Output conducted	-	Set-up No.	Cel-C1	Cel-C2	BT1	W1	W2	--	-
		9 kHz - 12.75 GHz	N/A	0.60	0.7	0.25	N/A	--	
		12.75 - 26.5GHz	N/A	0.82	--	N/A	N/A	--	
Conducted emissions on RF-port	-	9 kHz - 2.8 GHz	0.70	N/A	0.70	N/A	0.69	--	N/A - not applicable
		2.8 GHz - 12.75GHz	1.48	N/A	1.51	N/A	1.43	--	
		12.75 GHz - 18GHz	1.81	N/A	1.83	N/A	1.77	--	
		18 GHz - 26.5GHz	1.83	N/A	1.85	N/A	1.79	--	
Occupied bandwidth	-	9 kHz - 4 GHz	0.1272 ppm (Delta Marker)						Frequency error
			1.0 dB						Power
Emission bandwidth	-	9 kHz - 4 GHz	0.1272 ppm (Delta Marker)						Frequency error
			See above: 0.70 dB						Power
Frequency stability	-	9 kHz - 20 GHz	0.0636 ppm						-
Radiated emissions Enclosure	-	150 kHz - 30 MHz	5.0 dB						Magnetic field E-field Substitution
		30 MHz - 1 GHz	4.2 dB						
		1 GHz - 20 GHz	3.17 dB						

**Table: measurement uncertainties, valid for conducted/radiated measurements**

## 6. Abbreviations used in this report

The abbreviations	
ANSI	American National Standards Institute
AV , AVG, CAV	Average detector
EIRP	Equivalent isotropically radiated power, determined within a separate measurement
EGPRS	Enhanced General Packet Radio Service
EUT	Equipment Under Test
FCC	Federal Communications Commission, USA
IC	Industry Canada
n.a.	not applicable
Op-Mode	Operating mode of the equipment
PK	Peak
RBW	resolution bandwidth
RF	Radio frequency
RSS	Radio Standards Specification, Dokuments from Industry Canada
Rx	Receiver
TCH	Traffic channel
Tx	Transmitter
QP	Quasi peak detector
VBW	Video bandwidth
ERP	Effective radiated power

## 7. Accreditation details of CETECOM's laboratories and test sites

Ref.-No.	Accreditation Certificate	Valid for laboratory area or test site	Accreditation Body
-	D-PL-12047-01-01	All laboratories and test sites of CETECOM GmbH, Essen	DAkkS, Deutsche Akkreditierungsstelle GmbH
337 487 558 348 348	736496	Radiated Measurements 30 MHz to 1 GHz, 3 m / 10 m (OATS) Radiated Measurements 30 MHz to 1 GHz, 3 m (SAR) Radiated Measurements above 1 GHz, 3 m (FAR) Mains Ports Conducted Interference Measurements Telecommunication Ports Conducted Interference Measurment.	FCC, Federal Communications Commission Laboratory Division, USA (MRA US-EU 0003)
337 487 550 558	3462D-1 3462D-2 3462D-2 3462D-3	Radiated Measurements 30 MHz to 1 GHz, 3 m / 10 m (OATS) Radiated Measurements 30 MHz to 1 GHz, 3 m (SAR) Radiated Measurements 1 GHz to 6 GHz, 3 m (SAR) Radiated Measurements above 1 GHz, 3 m (FAR)	IC, Industry Canada Certification and Engineering Bureau
487 550 348 348	R-2666 G-301 C-2914 T-1967	Radiated Measurements 30 MHz to 1 GHz, 3 m (SAR) Radiated Measurements 1 GHz to 6 GHz, 3 m (SAR) Mains Ports Conducted Interference Measurements Telecommunication Ports Conducted Interference Measurment.	VCCI, Voluntary Control Council for Interference by Information Technology Equipment, Japan

OATS = Open Area Test Site, SAR = Semi Anechoic Room, FAR = Fully Anechoic Room

## 8. Instruments and Ancillary

### 8.1. Used equipment “CTC”

The “Ref.-No” in the left column of the following tables allows the clear identification of the laboratory equipment.

#### 8.1.1. Test software and firmware of equipment

Ref.-No.	Equipment	Type	Serial-No.	Version of Firmware or Software during the test
001	EMI Test Receiver	ESS	825132/017	Firm.= 1.21 , OTP=2.0, GRA=2.0
012	Signal Generator (EMS-cond.)	SMY 01	839069/027	Firm.= V 2.02
013	Power Meter (EMS cond.)	NRVD	839111/003	Firm.= V 1.51
017	Digital Radiocommunication Tester	CMD 60 M	844365/014	Firmware = V 3.52 .22.01.99, DECT = D2.87 13.01.99
119	RT Harmonics Analyzer dig. Flickermeter	B10	G60547	Firm.= V 3.1DHG
261	Thermal Power Sensor	NRV-Z55	825083/0008	EPROM-Datum 02.12.04, SE EE 1 B
262	Power Meter	NRV-S	825770/0010	Firm.= 2.6
263	Signal Generator	SMP 04	826190/0007	Firm.=3.21
295	Racal Digital Radio Test Set	6103	1572	UNIT Firmware= 4.04, SW-Main=4.04, SW- BBP=1.04, SW-DSP=1.02, Hardboot=1.02, Softboot=2.02
298	Univ. Radio Communication Tester	CMU 200	832221/091	R&S Test Firmware =3.53 /3.54 (current Testsoftw. f. all band used
323	Digital Radiocommunication Tester	CMD 55	825878/0034	Firm.= 3.52 .22.01.99
335	CTC-EMS-Conducted	System EMS Conducted	-	EMC 32 V 8.52
340	Digital Radiocommunication Tester	CMD 55	849709/037	Firm.= 3.52 .22.01.99
366	Ultra Compact Simulator	UCS 500 M4	V0531100594	Firm. UCS 500=001925/3.06a02, rc=ISMIEC 4.10
371	Bluetooth Tester	CBT32	100153	CBT V5,30+ SW-Option K55, K57
377	EMI Test Receiver	ESCS 30	100160	Firm.= 2.30, OTP= 02.01, GRA= 02.36
378	Broadband RF Field Monitor	RadiSense III	03D00013SNO-08	Firm.= V.03D13
389	Digital Multimeter	Keithley 2000	0583926	Firm. = A13 (Mainboard) A02 (Display)
392	Radio Communication Tester	MT8820A	6K00000788	Firm.= 4.50 #005, IPL=4.01#001,OS=4.02#001, GSM=4.41#013, W-CDMA= 4.54#004, scenario=
436	Univ. Radio Communication Tester	CMU 200	103083	R&S Test Firmware Base=5.14, Mess-Software= GSM:5.14 WCDMA:5.14 (current Testsoftw. F. all band
441	CTC-SAR-EMI Cable Loss	System EMI field (SAR)	-	EMC 32 Version 8.52
442	CTC-SAR-EMS	System EMS field (SAR)	-	EMC 32 Version 8.40
443	CTC-FAR-EMI-RSE	System CTC-FAR-EMI-RSE	-	Spuri 7.2.5 or EMC 32 Ver. 9.15.00
444	CTC-FAR-EMS field	System-EMS-Field (FAR)	-	EMC 32 Version 9.15.00
460	Univ. Radio Communication Tester	CMU 200	108901	R&S Test Firmware Base=5.14, GSM=5.14 WCDMA=5.14 (current Testsoftw.,f. all band to be used,
489	EMI Test Receiver	ESU40	1000-30	Firmware=4.43 SP3, Bios=V5.1-16-3, Spec. =01.00
491	ESD Simulator dito	ESD dito	dito307022	V 2.30
524	Voltage Drop Simulator	VDS 200	0196-16	Software Nr. 000037 Version V4.20a01
526	Burst Generator	EFT 200 A	0496-06	Software Nr. 000034 Version V2.32
527	Micro Pulse Generator	MPG 200 B	0496-05	Software-Nr. 000030 Version V2.43
528	Load Dump Simulator	LD 200B	0496-06	Software-Nr. 000031 Version V2.35a01
546	Univ. Radio Communication Tester	CMU 200	106436	R&S Test Firmware Base=5.14, GSM=5.14 WCDMA=5.14 (current Testsoftw.,f. all band to be used
547	Univ. Radio Communication Tester	CMU 200	835390/014	R&S Test Firmware Base=V5.1403 (current Testsoftw., f. all band used, GSM = 5.14 WCDMA: = 5.14
584	Spectrum Analyzer	FSU 8	100248	2.82_SP3
597	Univ. Radio Communication Tester	CMU 200	100347	R&S Test Firmware Base=5.01, GSM=5.02 WCDMA= not installed, Mainboard= µP1=V.850
607	Signal Generator	SMR 20	832033/011	V1.25
620	EMI Test Receiver	ESU 26	100362	4.43_SP3
642	Wideband Radio Communication Tester	CMW 500	126089	Setup V03.26, Test programm component V03.02.20
670	Univ. Radio Communication Tester	CMU 200	106833	µP1 =V8.50, Firmware = V.20
689	Vector Signal Generator	SMU200	100970	02.20.360.142
692	Bluetooth Tester	CBT 32	100236	CBT V 5.40, FW: V.2.41 (FPGA Digital, V. 3.09 FPGA RF)
699	Audio Analyzer	UPL16	833494/005	3.06

### 8.1.2. Single instruments and test systems

Ref.-No.	Equipment	Type	Serial-No.	Manufacturer	Interval of calibration	Remark	Cal due
001	EMI Test Receiver	ESS	825132/017	Rohde & Schwarz	12 M	-	16.05.2019
005	AC - LISN (50 Ohm/50µH, test site 1)	ESH2-Z5	861741/005	Rohde & Schwarz	12 M	-	16.05.2019
007	Single-Line V-Network (50 Ohm/5µH)	ESH3-Z6	892563/002	Rohde & Schwarz	12 M	-	16.05.2019
009	Power Meter (EMS-radiated)	NRV	863056/017	Rohde & Schwarz	24 M	-	15.05.2019
016	Line Impedance Simulating Network	Op. 24-D	B6366	Spitzenberger+Spies	36 M	-	30.05.2019
020	Horn Antenna 18 GHz (Subst 1)	3115	9107-3699	EMCO	36/12 M	-	31.07.2021
021	Loop Antenna (H-Field)	6502	9206-2770	EMCO	36 M	-	30.05.2021
030	Loop Antenna (H-field)	HFH-Z2	879604/026	Rohde & Schwarz	36 M	-	30.04.2018
033	RF-current probe (100kHz-30MHz)	ESH2-Z1	879581/18	Rohde & Schwarz	24 M	-	15.05.2019
057	relay-switch-unit (EMS system)	RSU	494440/002	Rohde & Schwarz	pre-m	1a	
060	power amplifier (DC-2kHz)	PAS 5000	B6363	Spitzenberger+Spies	-	3	
086	DC - power supply, 0 -10 A	LNG 50-10	-	Heinzinger Electronic	pre-m	2	
087	DC - power supply, 0 -5 A	EA-3013 S	-	Elektro Automatik	pre-m	2	
091	USB-LWL-Converter	OLS-1	007/2006	Ing. Büro Scheiba	-	4	
099	passive voltage probe	ESH2-Z3	299.7810.52	Rohde & Schwarz	36 M	-	30.05.2021
100	passive voltage probe	Probe TK 9416	without	Schwarzbeck	36 M	-	30.05.2021
110	USB-LWL-Converter	OLS-1	-	Ing. Büro Scheiba	-	4	
119	RT Harmonics Analyzer dig. Flickermeter	B10	G60547	BOCONSULT	36 M	-	30.05.2019
133	horn antenna 18 GHz (Meas 1)	3115	9012-3629	EMCO	36 M	1c	10.03.2020
134	horn antenna 18 GHz (Subst 2)	3115	9005-3414	EMCO	36 M	-	10.03.2020
248	attenuator	SMA 6dB 2W	-	Radiall	pre-m	2	
249	attenuator	SMA 10dB 10W	-	Radiall	pre-m	2	
252	attenuator	N 6dB 12W	-	Radiall	pre-m	2	
256	attenuator	SMA 3dB 2W	-	Radiall	pre-m	2	
257	hybrid	4031C	04491	Narda	pre-m	2	
260	hybrid coupler	4032C	11342	Narda	pre-m	2	
261	Thermal Power Sensor	NRV-Z55	825083/0008	Rohde & Schwarz	24 M	-	30.05.2020
262	Power Meter	NRV-S	825770/0010	Rohde & Schwarz	24 M	-	30.05.2019
263	Signal Generator	SMP 04	826190/0007	Rohde & Schwarz	36 M	-	30.05.2019
265	peak power sensor	NRV-Z33, Model 04	840414/009	Rohde & Schwarz	24 M	-	30.05.2020
266	Peak Power Sensor	NRV-Z31, Model 04	843383/016	Rohde & Schwarz	24 M	-	30.05.2020
267	notch filter GSM 850	WRCA 800/960-6EEK	9	Wainwright GmbH	pre-m	2	
270	termination	1418 N	BB6935	Weinschel	pre-m	2	
271	termination	1418 N	BE6384	Weinschel	pre-m	2	
272	attenuator (20 dB) 50 W	Model 47	BF6239	Weinschel	pre-m	2	
273	attenuator (10 dB) 100 W	Model 48	BF9229	Weinschel	pre-m	2	
274	attenuator (10 dB) 50 W	Model 47 (10 dB) 50 W	BG0321	Weinschel	pre-m	2	
275	DC-Block	Model 7003 (N)	C5129	Weinschel	pre-m	2	
276	DC-Block	Model 7006 (SMA)	C7061	Weinschel	pre-m	2	
279	power divider	1515 (SMA)	LH855	Weinschel	pre-m	2	
298	Univ. Radio Communication Tester	CMU 200	832221/091	Rohde & Schwarz	pre-m	3	
300	AC LISN (50 Ohm/50µH, 1-phase)	ESH3-Z5	892 239/020	Rohde & Schwarz	12 M	-	17.05.2019
301	attenuator (20 dB) 50W, 18GHz	47-20-33	AW0272	Lucas Weinschel	pre-m	2	
302	horn antenna 40 GHz (Meas 1)	BBHA9170	155	Schwarzbeck	36 M	-	14.03.2020
303	horn antenna 40 GHz (Subst 1)	BBHA9170	156	Schwarzbeck	36 M	-	20.03.2020
331	Climatic Test Chamber -40/+180 Grad	HC 4055	43146	Heraeus Vötsch	24 M	-	30.10.2018
341	Digital Multimeter	Fluke 112	81650455	Fluke	24 M	-	30.05.2020
342	Digital Multimeter	Voltcraft M-4660A	IB 255466	Voltcraft	24 M	-	17.05.2019
347	laboratory site	radio lab.	-	-	-	5	
348	laboratory site	EMI conducted	-	-	-	5	

Ref.-No.	Equipment	Type	Serial-No.	Manufacturer	Interval of calibration	Remark	Cal due
354	DC - Power Supply 40A	NGPE 40/40	448	Rohde & Schwarz	pre-m	2	
357	power sensor	NRV-Z1	861761/002	Rohde & Schwarz	24 M	-	24.05.2019
371	Bluetooth Tester	CBT32	100153	R&S	36 M	-	30.05.2019
373	Single-Line V-Network (50 Ohm/5µH)	ESH3-Z6	100535	Rohde & Schwarz	12 M	-	17.05.2019
377	EMI Test Receiver	ESCS 30	100160	Rohde & Schwarz	12 M	-	30.05.2019
389	Digital Multimeter	Keithley 2000	0583926	Keithley	pre-m	-	
392	Radio Communication Tester	MT8820A	6K00000788	Anritsu	12 M	-	30.06.2019
405	Thermo-/Hygrometer	OPUS 10 THI	126.0604.0003.3.3.3.22	LUFFT Mess u. Regeltechnik GmbH	24 M	-	30.03.2019
431	Model 7405	Near-Field Probe Set	9305-2457	EMCO	-	4	
436	Univ. Radio Communication Tester	CMU 200	103083	Rohde & Schwarz	12 M	-	06.03.2019
439	UltraLog-Antenna	HL 562	100248	Rohde & Schwarz	36 M	-	10.03.2020
454	Oscilloscope	HM 205-3	9210 P 29661	Hameg	-	4	
456	DC-Power supply 0-5 A	EA 3013 S	207810	Elektro Automatik	pre-m	2	
459	DC -Power supply 0-5 A , 0-32 V	EA-PS 2032-50	910722	Elektro Automatik	pre-m	2	
460	Univ. Radio Communication Tester	CMU 200	108901	Rohde & Schwarz	12 M	-	30.05.2019
463	Universal source	HP3245A	2831A03472	Agilent	-	4	
466	Digital Multimeter	Fluke 112	89210157	Fluke USA	24 M	-	30.05.2020
467	Digital Multimeter	Fluke 112	89680306	Fluke USA	36 M	-	30.05.2019
468	Digital Multimeter	Fluke 112	90090455	Fluke USA	36 M	-	30.04.2021
477	ReRadiating GPS-System	AS-47	-	Automotive Cons. Fink	-	3	
480	power meter (Fula)	NRVS	838392/031	Rohde & Schwarz	24 M	-	16.05.2019
482	filter matrix	Filter matrix SAR 1	-	CETECOM (Brl)	-	1d	
487	System CTC NSA-Verification SAR-EMI	System EMI field (SAR) NSA	-	ETS Lindgren / CETECOM	24 M	-	31.03.2019
489	EMI Test Receiver	ESU40	1000-30	Rohde & Schwarz	12 M	-	30.06.2019
502	band reject filter	WRCG 1709/1786-1699/1796-	SN 9	Wainwright	pre-m	2	
503	band reject filter	WRCG 824/849-814/859-60/10SS	SN 5	Wainwright	pre-m	2	
517	relais switch matrix	HF Relais Box Keithley System	SE 04	Keithley	pre-m	2	
523	Digital Multimeter	L4411A	MY46000154	Agilent	24 M	-	18.05.2019
529	6 dB Broadband resistive power divider	Model 1515	LH 855	Weinschel	pre-m	2	
530	10 dB Broadband resistive power divider	R 416110000	LOT 9828	-	pre-m	2	
546	Univ. Radio Communication Tester	CMU 200	106436	R&S	12 M	-	30.07.2019
547	Univ. Radio Communication Tester	CMU 200	835390/014	Rohde & Schwarz	12 M	-	30.07.2019
549	Log.Per-Antenna	HL025	1000060	Rohde & Schwarz	36/12 M	-	31.07.2021
550	System CTC S-VSWR Verification SAR-EMI	System EMI Field SAR S-VSWR	-	ETS Lindgren/CETECOM	24 M	-	30.03.2019
558	System CTC FAR S-VSWR	System CTC FAR S-VSWR	-	CTC	24 M	-	08.08.2019
574	Biconilog Hybrid Antenna	BTA-L	980026L	Frankonia	36/12 M	-	31.03.2019
584	Spectrum Analyzer	FSU 8	100248	Rohde & Schwarz	pre-m	-	
594	Wideband Radio Communication Tester	CMW 500	101757	Rohde & Schwarz	12 M	-	30.05.2019
597	Univ. Radio Communication Tester	CMU 200	100347	Rohde & Schwarz	pre-m	-	
600	power meter	NRVD (Reserve)	834501/018	Rohde & Schwarz	24 M	-	17.05.2019
601	medium-sensitivity diode sensor	NRV-Z5 (Reserve)	8435323/003	Rohde & Schwarz	24 M	-	15.05.2019
602	peak power sensor	NRV-Z32 (Reserve)	835080	Rohde & Schwarz	24 M	-	
611	DC power supply	E3632A	KR 75305854	Agilent	pre-m	2	
612	DC power supply	E3632A	MY 40001321	Agilent	pre-m	2	
613	Attenuator	R416120000 20dB 10W	Lot. 9828	Radiall	pre-m	2	
616	Digitalmultimeter	Fluke 177	88900339	Fluke	24 M	-	30.05.2020
617	Power Splitter/Combiner	ZFSC-2-2-S+	S F987001108	Mini Circuits	-	2	
618	Power Splitter/Combiner	50PD-634	600994	JFW Industries USA	-	2	
619	Power Splitter/Combiner	50PD-634	600995	JFW Industries, USA	-	3	
620	EMI Test Receiver	ESU 26	100362	Rohde-Schwarz	12 M	-	30.05.2019
621	Step Attenuator 0-139 dB	RSP	100017	Rohde & Schwarz	pre-m	2	
625	Generic Test Load USB	Generic Test Load USB	-	CETECOM	-	2	

Ref.-No.	Equipment	Type	Serial-No.	Manufacturer	Interval of calibration	Remark	Cal due
627	data logger	OPUS 1	201.0999.9302.6.4.1.43	G. Luft GmbH	24 M	-	30.03.2019
634	Spectrum Analyzer	FSM (HF-Unit)	826188/010	Rohde & Schwarz	pre-m	2	
637	High Speed HDMI with Ethernet 1m	HDMI cable with Ethernet 1m	-	KogiLink	-	2	
638	HDMI Kabel with Ethernet 1,5 m flach	HDMI cable with Ethernet 1,5m	-	Reichelt	-	2	
640	HDMI cable 2m rund	HDMI cable 2m rund	-	Reichelt	-	2	
641	HDMI cable with Ethernet	Certified HDMI cable with	-	PureLink	-	2	
642	Wideband Radio Communication Tester	CMW 500	126089	Rohde&Schwarz	24 M	-	24.05.2019
644	Amplifier	ZX60-2534M+	SN865701299	Mini-Circuits	-	-	
670	Univ. Radio Communication Tester	CMU 200	106833	Rohde & Schwarz	24 M	-	30.05.2020
671	DC-power supply 0-5 A	EA-3013S	-	Elektro Automatik	pre-m	2	
678	Power Meter	NRP	101638	Rohde&Schwarz	pre-m	-	
683	Spectrum Analyzer	FSU 26	200571	Rohde & Schwarz	12 M	-	30.05.2019
686	Field Analyzer	EHP-200A	160WX30702	Narda Safety Test Solutions	24 M	-	29.03.2019
687	Signal Generator	SMF 100A	102073	Rohde&Schwarz	12 M	-	30.05.2019
688	Pre Amp	JS-18004000-40-8P	1750117	Miteq	pre-m	-	
690	Spectrum Analyzer	FSU	100302/026	Rohde&Schwarz	24 M	-	16.05.2019
691	OSP120 Base Unit	OSP120	106833	Rohde & Schwarz	12 M	-	30.05.2019
692	Bluetooth Tester	CBT 32	100236	Rohde & Schwarz	36 M	-	29.05.2020
693	TS8997	CTC-Radio Lab 1_TS8997	-	Rohde&Schwarz	12 M	5	30.05.2019
697	Power Splitter	ZN4PD-642W-S+	165001445	Mini-Circuits	-	2	
701	CMW500 wide. Radio Comm.	CMW500	158150	Rohde & Schwarz	12 M	-	30.07.2019
703	INNCO Antennen Mast	MA 4010-KT080-XPET-ZSS3	MA4170-KT100-XPET-ZSS3	INNCO	pre-m	-	
704	INNCON Controller	CO 3000-4port	CO3000/933/38410516/L	INNCO Systems GmbH	pre-m	-	
711	Harmonic Mixer 90 GHz - 140GHz	RPG FS-Z140	101004	RPG	36 M	-	22.02.2020
712	Harmonic Mixer 75 GHz - 110GHz	FS-Z110	101468	Rohde & Schwarz	36 M	-	22.02.2020
713	Harmonic Mixer, 50 GHz - 75GHz	FS-Z75	101022	Rohde & Schwarz	36 M	-	22.05.2020
714	Signal Analyzer 67GHz	FSW67	104023	Rohde & Schwarz	24 M	-	28.02.2020
715	Harmonic Mixer, 140 GHz - 220GHz	FS-Z220	101009	RPG Radiometer Physics	36 M	-	03.08.2020
716	Harmonic Mixer 220 GHz to 325 GHz	FS-Z325	101005	RPG Radiometer Physics	36 M	-	13.02.2020
747	Spectrum Analyzer	FSU 26	200152	Rohde & Schwarz	12 M	-	30.05.2019
748	Pickett-Potter Horn Antenna	FH-PP 4060	010001	Radiometer Physics	36 M	-	
749	Pickett-potter Horn Antenna	FH-PP 60-90	010003	Radiometer Physics	-	-	
750	Pickett-Potter Horn Antenna	FH-PP 140-220	010011	Radiometer Physics	-	-	
751	Digital Optical System	optoCAN-FD Transceiver	17-010416	mk-messtechnik GmbH	-	-	
752	Digital Optical System	optoCAN-FD Transceiver	17-010083	mk-messtechnik GmbH	-	-	
753	Digital Optical System	optoCAN-FD Transceiver	17-010084	mk-messtechnik GmbH	-	-	
754	Digital Optical System	optoCAN-FD Transceiver	17-010415	mk-messtechnik GmbH	-	-	
755	Digital Optical System	optoLAN-100-MAX Transceiver	17-010795	mk-messtechnik GmbH	-	-	
757	WIDEBAND RADIO COMMUNICATION	CMW500	163673	Rohde&Schwarz	12 M	-	20.07.2018
758	Signal Generator	SMU 200A	100754	Rohde & Schwarz	24 M	-	11.10.2019
780	Spectrum Analyzer	FSH3	101726	Rohde & Schwarz	24 M	-	19.07.2019
781	Power Supply	PS 2042-10 B	2815450369	Elektro-Automatik GmbH & Co.KG	-	-	
782	Power Supply	PS 2042-10 B	2815450348	lektro-Automatik GmbH & Co.KG	-	-	
783	Spectrum Analyzer	FSU 26	100414	Rohde & Schwarz	12 M	-	30.05.2019
784	Power Supply	NGSM 32/10	00196	Rohde & Schwarz	12 M	-	
785	RSP	RF Step Attenuator 0...139,9dB	860712/012	Rohde & Schwarz	12 M	-	
786	SAR Probe	ES3DV3	3340	Speag	36 M	-	14.02.2021
787	OSP	OSP B157WX	101264	Rohde & Schwarz	12 M	-	30.05.2019
788	Precision Omnidirectional Dipole	POD 618	6182558/Q	Seibersdorf Laboratories	36 M	-	30.06.2021
789	Precision Omnidirectional Dipole	POD 16	162496/Q	Seibersdorf Laboratories	36 M	-	30.06.2021



Note / remarks		Calibrated during system calibration:
	1a	System CTC-SAR-EMS (Ref.-No. 442)
	1b	System-CTC-EMS-Conducted (Ref.-No. 335)
	1c	System CTC-FAR-EMI-RSE (Ref.-No . 443)
	1d	System CTC-SAR-EMI (Ref.-No . 441)
	1e	System CTC-OATS (EMI radiated) (Ref.-No. 337)
	1 f	System CTC-CTIA-OTA (Ref.-No . 420)
	1 g	System CTC-FAR-EMS (Ref.-No . 444)
	2	Calibration or equipment check immediately before measurement
	3	Regulatory maintained equipment for functional check or support purpose
	4	Ancillary equipment without calibration e.g. mechanical equipment or monitoring equipment
	5	Test System

Interval of calibration	12 M	12 month
	24 M	24 month
	36 M	36 month
	24/12 M	Calibration every 24 months, between this every 12 months internal validation
	36/12 M	Calibration every 36 months, between this every 12 months internal validation
	Pre-m	Check before starting the measurement
	-	Without calibration

## 9. Versions of test reports (change history)

Version	Applied changes	Date of release
--	Initial release	2018-09-07
C01	HVIN updated, module report reference	2018-09-25