Appendix for the Report

Dosimetric Assessment of the Portable Device Datalogic Joya+ A (FCC ID: U4GA056) (IC ID: 3862E-MA056) (Contains FCC ID: U4G004W) (Contains IC: 3862E-004W)

According to the FCC and IC Requirements SAR Distribution Plots

April 15, 2011

IMST GmbH
Carl-Friedrich-Gauß-Str. 2
D-47475 Kamp-Lintfort

Customer
7layers AG
Borsigstrasse 11
D-40880 Ratingen

The test results only relate to the items tested. This report shall not be reproduced except in full without the written approval of the testing laboratory.

Table of Contents

1	SAR DISTRIBUTION PLOTS, IEEE 802.11 B	3
2	SAR DISTRIBUTION PLOTS, IEEE 802.11 G	4
3	SAR DISTRIBUTION PLOTS, IEEE 802.11 A (5200 MHZ RANGE).....	5
4	SAR DISTRIBUTION PLOTS, IEEE 802.11 A (5500 MHZ RANGE).....	9
5	SAR DISTRIBUTION PLOTS, IEEE 802.11 A (5800 MHZ RANGE).....	13
6	SAR Z-AXIS SCANS (VALIDATION)	15
7	SAR Z-AXIS SCANS (MEASUREMENTS).....	17

1 SAR Distribution Plots, IEEE 802.11 b

Test Laboratory: IMST GmbH, DASY Blue (I); File Name: [Joya_ywhm_b_CH6_dspl_down.da4](#)

DUT: Datalogic; Type: Joya+ A; Serial: D10P00437

Program Name: WLAN

Communication System: WLAN 2450; Frequency: 2437 MHz; Duty Cycle: 1:1

Medium parameters used (interpolated): $f = 2437$ MHz; $\sigma = 2.02$ mho/m; $\epsilon_r = 52.2$; $\rho = 1000$ kg/m³

Phantom section: Flat Section

DASY4 Configuration:

- Probe: EX3DV4 - SN3536; ConvF(7.48, 7.48, 7.48); Calibrated: 16.09.2010

- Sensor-Surface: 4mm (Mechanical Surface Detection)

- Electronics: DAE4 Sn631; Calibrated: 17.09.2010

- Phantom: SAM Glycol 1340; Type: QD 000 P40 CB; Serial: TP-1340

- Measurement SW: DASY4, V4.7 Build 80; Postprocessing SW: SEMCAD, V1.8 Build 186

Body Worn/Area Scan (9x14x1): Measurement grid: dx=15mm, dy=15mm

Maximum value of SAR (measured) = 0.172 mW/g

Body Worn/Zoom Scan (7x7x7)/Cube 0: Measurement grid: dx=5mm, dy=5mm, dz=5mm

Reference Value = 5.37 V/m; Power Drift = 0.081 dB

Peak SAR (extrapolated) = 0.313 W/kg

SAR(1 g) = 0.168 mW/g; SAR(10 g) = 0.094 mW/g

Maximum value of SAR (measured) = 0.183 mW/g

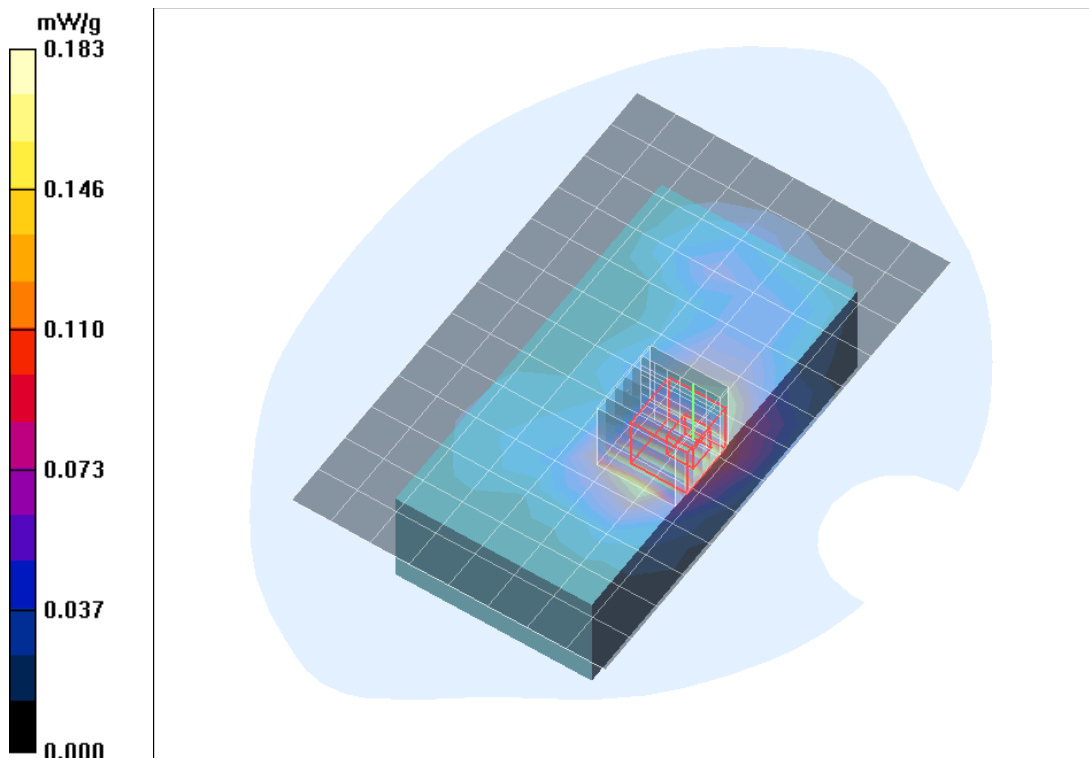

Fig. 1: SAR distribution for IEEE 802.11 b, channel 6, body worn configuration, display towards the ground, 0 mm distance (January 31, 2011; Ambient Temperature: 22.0° C; Liquid Temperature: 21.8° C).

2 SAR Distribution Plots, IEEE 802.11 g

Test Laboratory: IMST GmbH, DASY Blue (I); File Name: [Joya_ywhm_g_CH6_dspl_down.da4](#)

DUT: Datalogic; Type: Joya+ A; Serial: D10P00437

Program Name: WLAN

Communication System: WLAN 2450; Frequency: 2437 MHz; Duty Cycle: 1:1

Medium parameters used (interpolated): $f = 2437$ MHz; $\sigma = 2.02$ mho/m; $\epsilon_r = 52.2$; $\rho = 1000$ kg/m³

Phantom section: Flat Section

DASY4 Configuration:

- Probe: EX3DV4 - SN3536; ConvF(7.48, 7.48, 7.48); Calibrated: 16.09.2010

- Sensor-Surface: 4mm (Mechanical Surface Detection)

- Electronics: DAE4 Sn631; Calibrated: 17.09.2010

- Phantom: SAM Glycol 1340; Type: QD 000 P40 CB; Serial: TP-1340

- Measurement SW: DASY4, V4.7 Build 80; Postprocessing SW: SEMCAD, V1.8 Build 186

Body Worn/Area Scan (9x14x1): Measurement grid: dx=15mm, dy=15mm

Maximum value of SAR (measured) = 0.184 mW/g

Body Worn/Zoom Scan (7x7x7)/Cube 0: Measurement grid: dx=5mm, dy=5mm, dz=5mm

Reference Value = 5.58 V/m; Power Drift = 0.122 dB

Peak SAR (extrapolated) = 0.323 W/kg

SAR(1 g) = 0.174 mW/g; SAR(10 g) = 0.097 mW/g

Maximum value of SAR (measured) = 0.191 mW/g

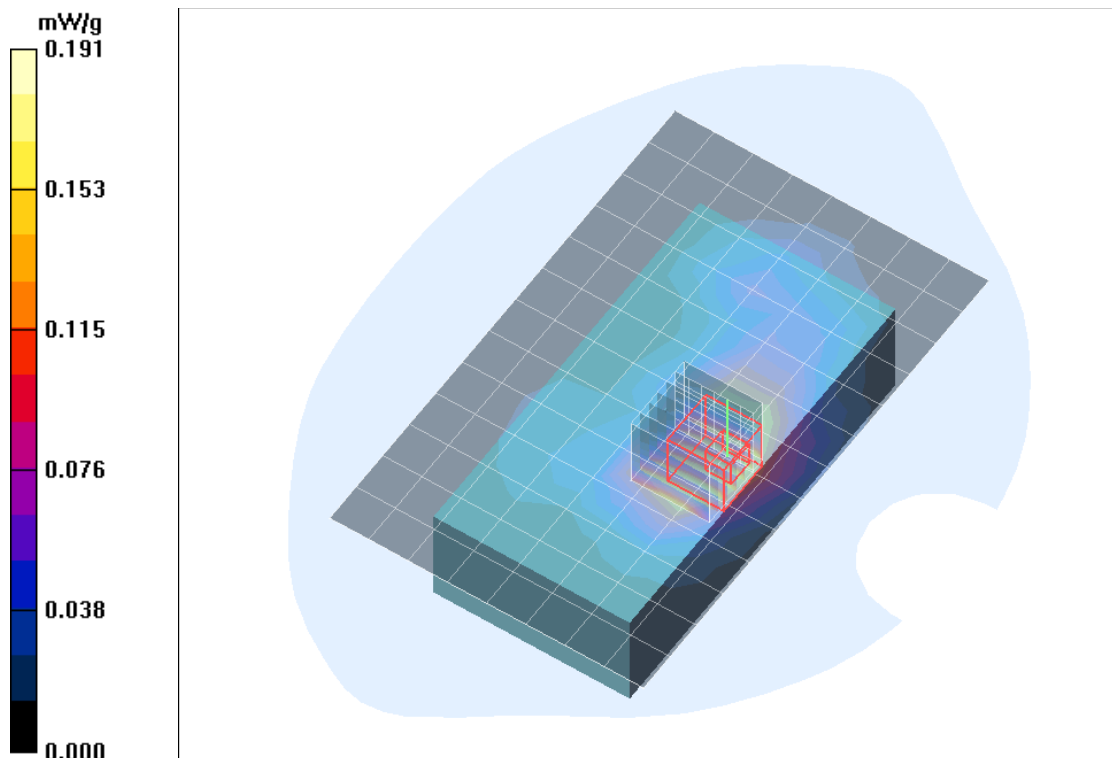

Fig. 2: SAR distribution for IEEE 802.11 g, channel 6, body worn configuration, display towards the ground, 0 mm distance (January 31, 2011; Ambient Temperature: 22.0° C; Liquid Temperature: 21.8° C).

3 SAR Distribution Plots, IEEE 802.11 a (5200 MHz Range)

Test Laboratory: IMST GmbH, DASY Blue (I); File Name: [Joya_bwhm_ch36_dspl_down.da4](#)

DUT: Datalogic; Type: Joya+ A; Serial: D10P00437

Program Name: WiFi 5200 MHz

Communication System: 5 GHz ; Frequency: 5180 MHz; Duty Cycle: 1:1

Medium parameters used: $f = 5180$ MHz; $\sigma = 5.22$ mho/m; $\epsilon_r = 48.8$; $\rho = 1000$ kg/m³

Phantom section: Flat Section

DASY4 Configuration:

- Probe: EX3DV4 - SN3536; ConvF(4.36, 4.36, 4.36); Calibrated: 16.09.2010
- Sensor-Surface: 2mm (Mechanical Surface Detection)
- Electronics: DAE4 Sn631; Calibrated: 17.09.2010
- Phantom: SAM Glycol 1176; Type: Speag; Serial: 1176
- Measurement SW: DASY4, V4.7 Build 80; Postprocessing SW: SEMCAD, V1.8 Build 186

Body Worn/Area Scan (12x19x1): Measurement grid: dx=10mm, dy=10mm

Maximum value of SAR (measured) = 0.414 mW/g

Body Worn/Zoom Scan (8x8x8)/Cube 0: Measurement grid: dx=4.3mm, dy=4.3mm, dz=3mm

Reference Value = 10.1 V/m; Power Drift = -0.108 dB

Peak SAR (extrapolated) = 0.829 W/kg

SAR(1 g) = 0.214 mW/g; SAR(10 g) = 0.075 mW/g

Maximum value of SAR (measured) = 0.508 mW/g

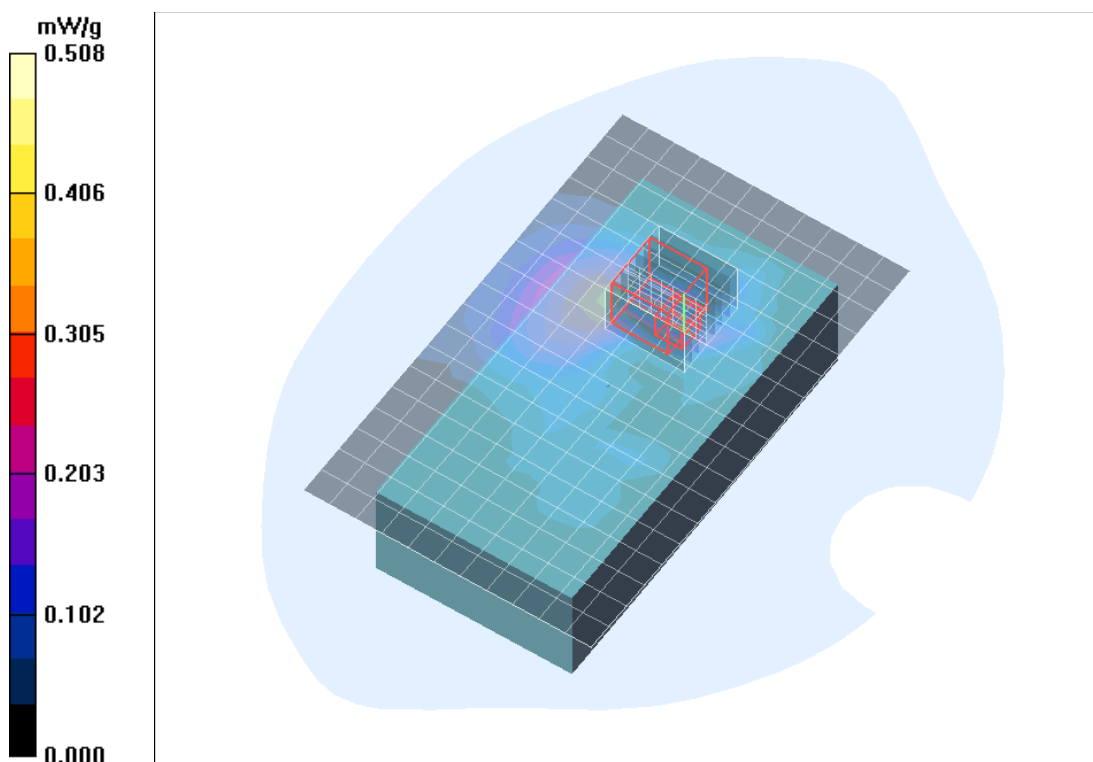

Fig. 3: SAR distribution for IEEE 802.11 a, channel 36, body worn configuration, display towards the ground, 0 mm distance (April 08, 2011; Ambient Temperature: 22.2° C; Liquid Temperature: 21.5° C).

Test Laboratory: IMST GmbH, DASY Blue (I); File Name: [Joya bwhm ch48 dspl down.da4](#)

DUT: Datalogic; Type: Joya+ A; Serial: D10P00437

Program Name: WiFi 5200 MHz

Communication System: 5 GHz ; Frequency: 5240 MHz; Duty Cycle: 1:1

Medium parameters used: $f = 5240$ MHz; $\sigma = 5.28$ mho/m; $\epsilon_r = 48.7$; $\rho = 1000$ kg/m³

Phantom section: Flat Section

DASY4 Configuration:

- Probe: EX3DV4 - SN3536; ConvF(4.36, 4.36, 4.36); Calibrated: 16.09.2010

- Sensor-Surface: 2mm (Mechanical Surface Detection)

- Electronics: DAE4 Sn631; Calibrated: 17.09.2010

- Phantom: SAM Glycol 1176; Type: Speag; Serial: 1176

- Measurement SW: DASY4, V4.7 Build 80; Postprocessing SW: SEMCAD, V1.8 Build 186

Body Worn/Area Scan (12x19x1): Measurement grid: dx=10mm, dy=10mm

Maximum value of SAR (measured) = 0.317 mW/g

Body Worn/Zoom Scan (8x8x8)/Cube 0: Measurement grid: dx=4.3mm, dy=4.3mm, dz=3mm

Reference Value = 8.91 V/m; Power Drift = -0.040 dB

Peak SAR (extrapolated) = 0.844 W/kg

SAR(1 g) = 0.164 mW/g; SAR(10 g) = 0.061 mW/g

Maximum value of SAR (measured) = 0.344 mW/g

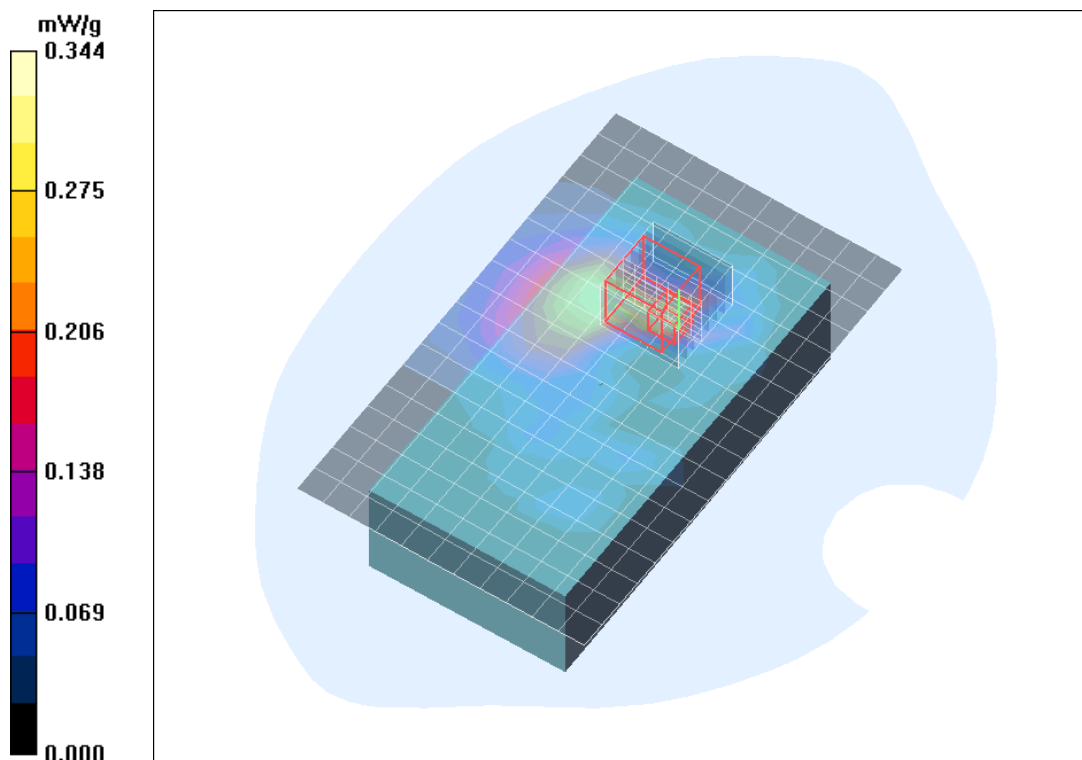

Fig. 4: SAR distribution for IEEE 802.11 a, channel 48, body worn configuration, display towards the ground, 0 mm distance (April 08, 2011; Ambient Temperature: 22.2° C; Liquid Temperature: 21.5° C).

Test Laboratory: IMST GmbH, DASY Blue (I); File Name: [Joya bwhm ch52 dspl down.da4](#)

DUT: Datalogic; Type: Joya+ A; Serial: D10P00437

Program Name: WiFi 5200 MHz

Communication System: 5 GHz ; Frequency: 5260 MHz; Duty Cycle: 1:1

Medium parameters used: $f = 5260$ MHz; $\sigma = 5.3$ mho/m; $\epsilon_r = 48.6$; $\rho = 1000$ kg/m³

Phantom section: Flat Section

DASY4 Configuration:

- Probe: EX3DV4 - SN3536; ConvF(4.13, 4.13, 4.13); Calibrated: 16.09.2010

- Sensor-Surface: 2mm (Mechanical Surface Detection)

- Electronics: DAE4 Sn631; Calibrated: 17.09.2010

- Phantom: SAM Glycol 1176; Type: Speag; Serial: 1176

- Measurement SW: DASY4, V4.7 Build 80; Postprocessing SW: SEMCAD, V1.8 Build 186

Body Worn/Area Scan (12x19x1): Measurement grid: dx=10mm, dy=10mm

Maximum value of SAR (measured) = 0.337 mW/g

Body Worn/Zoom Scan (8x8x8)/Cube 0: Measurement grid: dx=4.3mm, dy=4.3mm, dz=3mm

Reference Value = 8.95 V/m; Power Drift = -0.049 dB

Peak SAR (extrapolated) = 0.568 W/kg

SAR(1 g) = 0.191 mW/g; SAR(10 g) = 0.079 mW/g

Maximum value of SAR (measured) = 0.341 mW/g

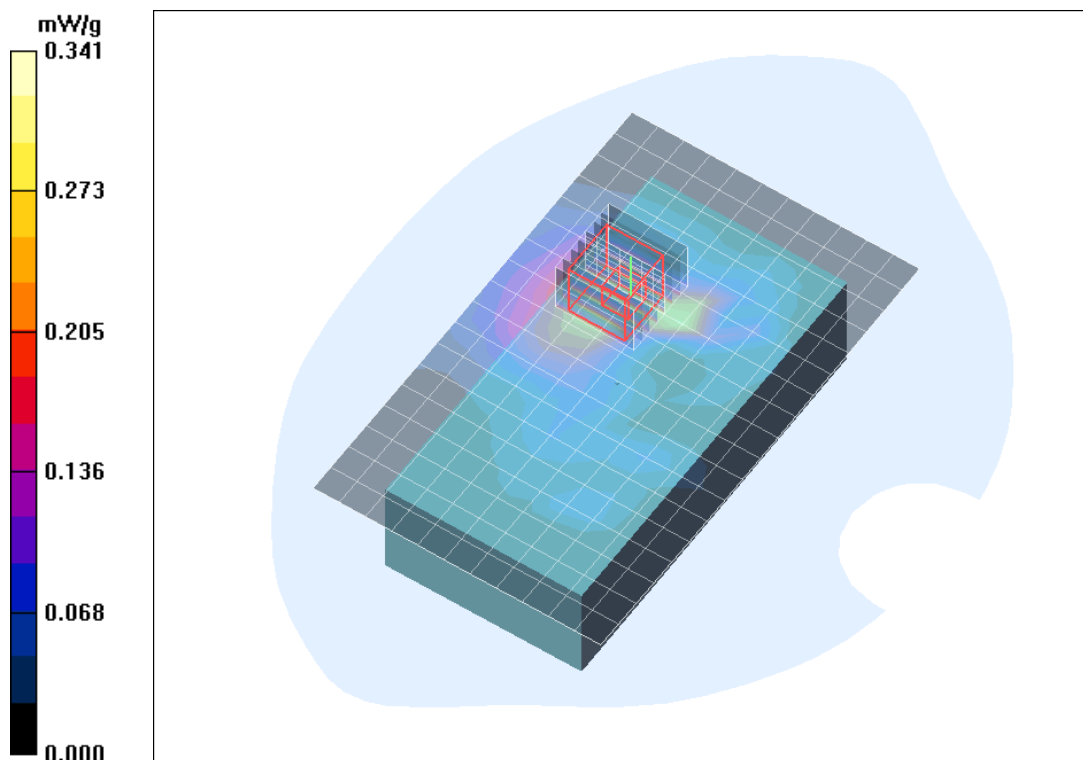

Fig. 5: SAR distribution for IEEE 802.11 a, channel 52, body worn configuration, display towards the ground, 0 mm distance (April 08, 2011; Ambient Temperature: 22.2° C; Liquid Temperature: 21.5° C).

Test Laboratory: IMST GmbH, DASY Blue (I); File Name: [Joya bwhm ch64 dspl down.da4](#)

DUT: Datalogic; Type: Joya+ A; Serial: D10P00437

Program Name: WiFi 5200 MHz

Communication System: 5 GHz ; Frequency: 5320 MHz; Duty Cycle: 1:1

Medium parameters used: $f = 5320$ MHz; $\sigma = 5.42$ mho/m; $\epsilon_r = 48.5$; $\rho = 1000$ kg/m³

Phantom section: Flat Section

DASY4 Configuration:

- Probe: EX3DV4 - SN3536; ConvF(4.13, 4.13, 4.13); Calibrated: 16.09.2010

- Sensor-Surface: 2mm (Mechanical Surface Detection)

- Electronics: DAE4 Sn631; Calibrated: 17.09.2010

- Phantom: SAM Glycol 1176; Type: Speag; Serial: 1176

- Measurement SW: DASY4, V4.7 Build 80; Postprocessing SW: SEMCAD, V1.8 Build 186

Body Worn/Area Scan (12x19x1): Measurement grid: dx=10mm, dy=10mm

Maximum value of SAR (measured) = 0.343 mW/g

Body Worn/Zoom Scan (8x8x8)/Cube 0: Measurement grid: dx=4.3mm, dy=4.3mm, dz=3mm

Reference Value = 9.01 V/m; Power Drift = 0.108 dB

Peak SAR (extrapolated) = 0.604 W/kg

SAR(1 g) = 0.187 mW/g; SAR(10 g) = 0.084 mW/g

Maximum value of SAR (measured) = 0.351 mW/g

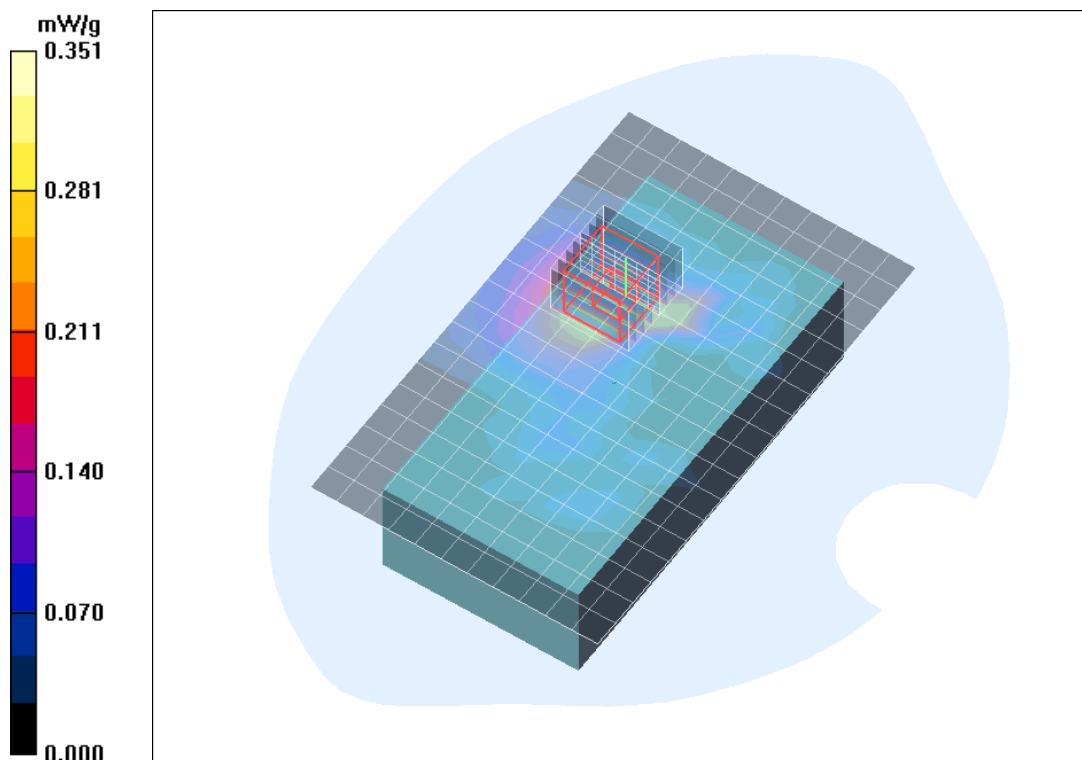

Fig. 6: SAR distribution for IEEE 802.11 a, channel 64, body worn configuration, display towards the ground, 0 mm distance (April 08, 2011; Ambient Temperature: 22.2° C; Liquid Temperature: 21.5° C).

4 SAR Distribution Plots, IEEE 802.11 a (5500 MHz Range)

Test Laboratory: IMST GmbH, DASY Blue (I); File Name: [Joya_bwhm_ch104_dspl_down.da4](#)

DUT: Datalogic; Type: Joya+ A; Serial: D10P00437

Program Name: WiFi 5500 MHz

Communication System: 5 GHz ; Frequency: 5520 MHz; Duty Cycle: 1:1

Medium parameters used: $f = 5520$ MHz; $\sigma = 5.71$ mho/m; $\epsilon_r = 48$; $\rho = 1000$ kg/m³

Phantom section: Flat Section

DASY4 Configuration:

- Probe: EX3DV4 - SN3536; ConvF(3.9, 3.9, 3.9); Calibrated: 16.09.2010
- Sensor-Surface: 2mm (Mechanical Surface Detection)
- Electronics: DAE4 Sn631; Calibrated: 17.09.2010
- Phantom: SAM Glycol 1176; Type: Speag; Serial: 1176
- Measurement SW: DASY4, V4.7 Build 80; Postprocessing SW: SEMCAD, V1.8 Build 186

Body Worn/Area Scan (12x19x1): Measurement grid: dx=10mm, dy=10mm

Maximum value of SAR (measured) = 0.309 mW/g

Body Worn/Zoom Scan (8x8x8)/Cube 0: Measurement grid: dx=4.3mm, dy=4.3mm, dz=3mm

Reference Value = 8.76 V/m; Power Drift = 0.027 dB

Peak SAR (extrapolated) = 0.564 W/kg

SAR(1 g) = 0.189 mW/g; SAR(10 g) = 0.080 mW/g

Maximum value of SAR (measured) = 0.336 mW/g

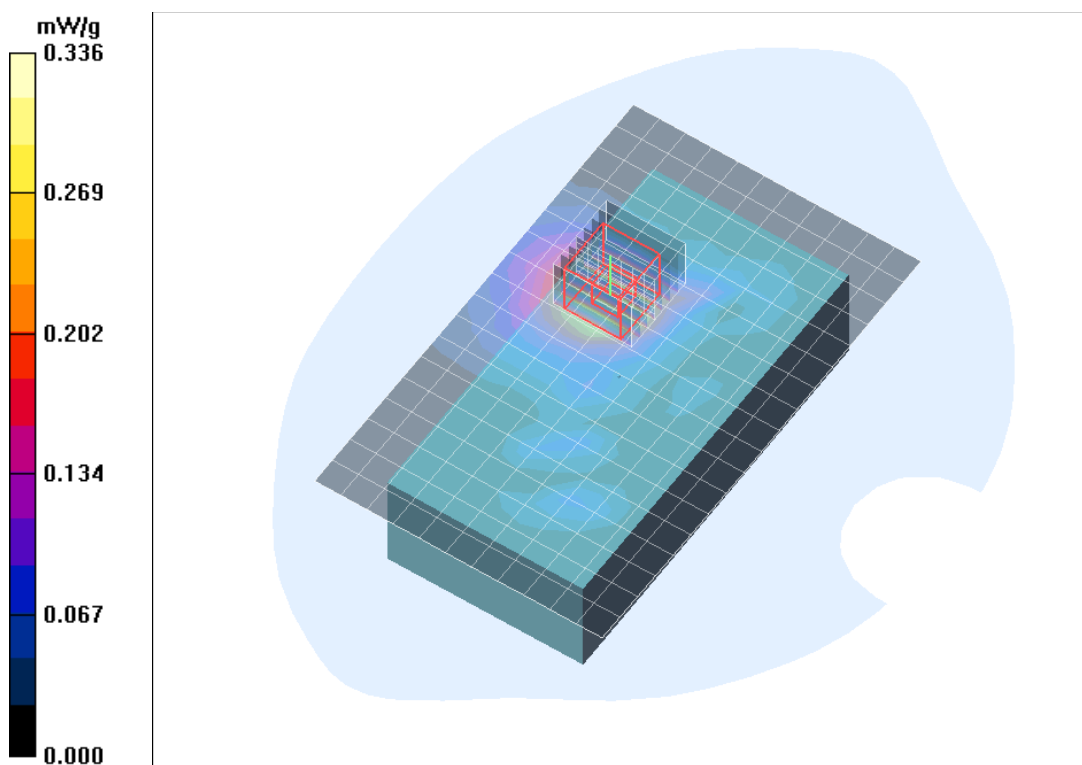

Fig. 7: SAR distribution for IEEE 802.11 a, channel 104, body worn configuration, display towards the ground, 0 mm distance (April 13, 2011; Ambient Temperature: 22.0° C; Liquid Temperature: 21.6° C).

Laboratory: IMST GmbH, DASY Blue (I); **File Name:** [Joya bwhm ch116 dspl down.da4](#)

DUT: Datalogic; **Type:** Joya+ A; **Serial:** D10P00437

Program Name: WiFi 5500 MHz

Communication System: 5 GHz ; Frequency: 5580 MHz; Duty Cycle: 1:1

Medium parameters used: $f = 5580$ MHz; $\sigma = 5.8$ mho/m; $\epsilon_r = 47.9$; $\rho = 1000$ kg/m³

Phantom section: Flat Section

DASY4 Configuration:

- Probe: EX3DV4 - SN3536; ConvF(3.9, 3.9, 3.9); Calibrated: 16.09.2010

- Sensor-Surface: 2mm (Mechanical Surface Detection)

- Electronics: DAE4 Sn631; Calibrated: 17.09.2010

- Phantom: SAM Glycol 1176; Type: Speag; Serial: 1176

- Measurement SW: DASY4, V4.7 Build 80; Postprocessing SW: SEMCAD, V1.8 Build 186

Body Worn/Area Scan (12x19x1): Measurement grid: dx=10mm, dy=10mm

Maximum value of SAR (measured) = 0.278 mW/g

Body Worn/Zoom Scan (8x8x8)/Cube 0: Measurement grid: dx=4.3mm, dy=4.3mm, dz=3mm

Reference Value = 8.16 V/m; Power Drift = -0.029 dB

Peak SAR (extrapolated) = 0.493 W/kg

SAR(1 g) = 0.172 mW/g; SAR(10 g) = 0.072 mW/g

Maximum value of SAR (measured) = 0.312 mW/g

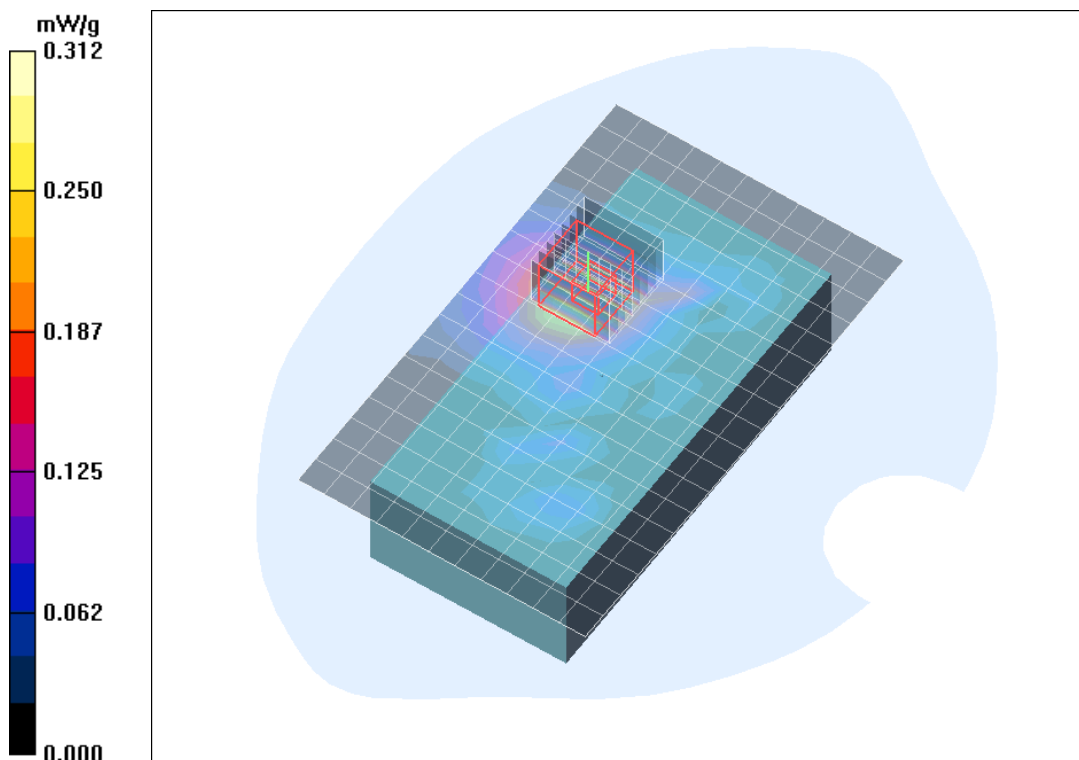

Fig. 8: SAR distribution for IEEE 802.11 a, channel 116, body worn configuration, display towards the ground, 0 mm distance (April 13, 2011; Ambient Temperature: 22.0° C; Liquid Temperature: 21.6° C).

Laboratory: IMST GmbH, DASY Blue (I); **File Name:** [Joya bwhm ch124 dspl down.da4](#)

DUT: Datalogic; **Type:** Joya+ A; **Serial:** D10P00437

Program Name: WiFi 5500 MHz

Communication System: 5 GHz ; Frequency: 5620 MHz; Duty Cycle: 1:1

Medium parameters used: $f = 5620$ MHz; $\sigma = 5.88$ mho/m; $\epsilon_r = 47.9$; $\rho = 1000$ kg/m³

Phantom section: Flat Section

DASY4 Configuration:

- Probe: EX3DV4 - SN3536; ConvF(3.9, 3.9, 3.9); Calibrated: 16.09.2010

- Sensor-Surface: 2mm (Mechanical Surface Detection)

- Electronics: DAE4 Sn631; Calibrated: 17.09.2010

- Phantom: SAM Glycol 1176; Type: Speag; Serial: 1176

- Measurement SW: DASY4, V4.7 Build 80; Postprocessing SW: SEMCAD, V1.8 Build 186

Body Worn/Area Scan (12x19x1): Measurement grid: dx=10mm, dy=10mm

Maximum value of SAR (measured) = 0.287 mW/g

Body Worn/Zoom Scan (8x8x8)/Cube 0: Measurement grid: dx=4.3mm, dy=4.3mm, dz=3mm

Reference Value = 7.99 V/m; Power Drift = 0.134 dB

Peak SAR (extrapolated) = 0.538 W/kg

SAR(1 g) = 0.174 mW/g; SAR(10 g) = 0.073 mW/g

Maximum value of SAR (measured) = 0.316 mW/g

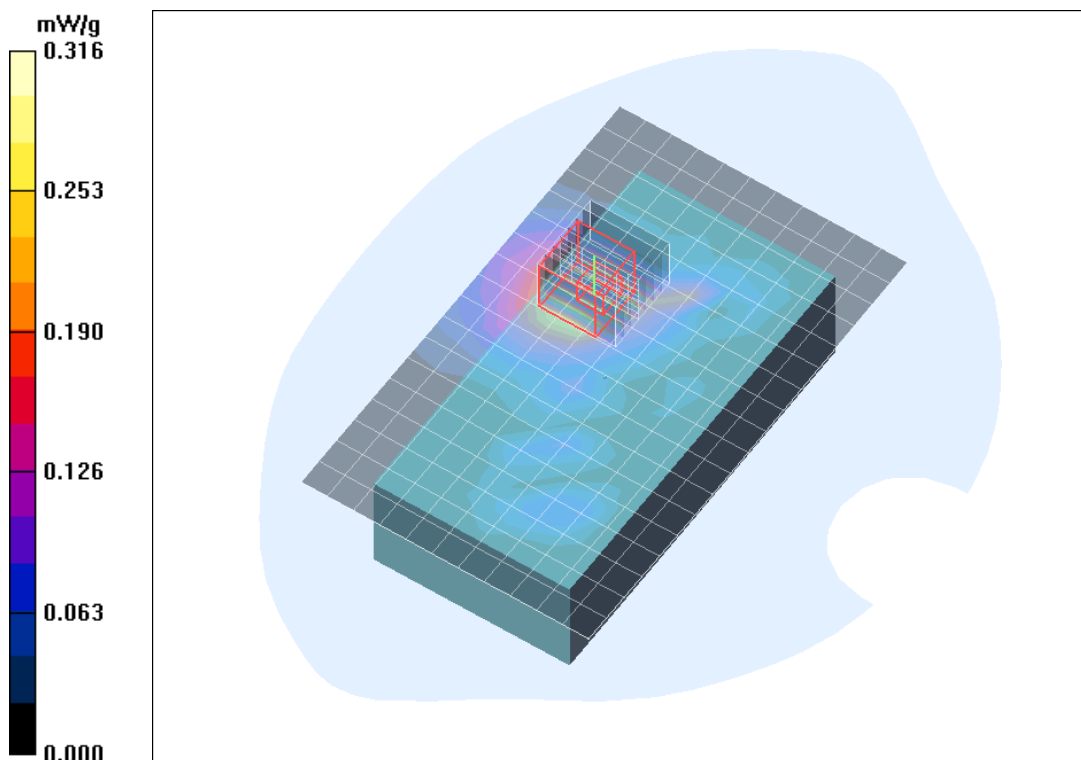

Fig. 9: SAR distribution for IEEE 802.11 a, channel 124, body worn configuration, display towards the ground, 0 mm distance (April 13, 2011; Ambient Temperature: 22.0° C; Liquid Temperature: 21.6° C).

Laboratory: IMST GmbH, DASY Blue (I); **File Name:** [Joya bwhm ch136 dspl down.da4](#)

DUT: Datalogic; **Type:** Joya+ A; **Serial:** D10P00437

Program Name: WiFi 5500 MHz

Communication System: 5 GHz ; Frequency: 5680 MHz; Duty Cycle: 1:1

Medium parameters used: $f = 5680$ MHz; $\sigma = 5.97$ mho/m; $\epsilon_r = 47.7$; $\rho = 1000$ kg/m³

Phantom section: Flat Section

DASY4 Configuration:

- Probe: EX3DV4 - SN3536; ConvF(3.9, 3.9, 3.9); Calibrated: 16.09.2010

- Sensor-Surface: 2mm (Mechanical Surface Detection)

- Electronics: DAE4 Sn631; Calibrated: 17.09.2010

- Phantom: SAM Glycol 1176; Type: Speag; Serial: 1176

- Measurement SW: DASY4, V4.7 Build 80; Postprocessing SW: SEMCAD, V1.8 Build 186

Body Worn/Area Scan (12x19x1): Measurement grid: dx=10mm, dy=10mm

Maximum value of SAR (measured) = 0.314 mW/g

Body Worn/Zoom Scan (8x8x8)/Cube 0: Measurement grid: dx=4.3mm, dy=4.3mm, dz=3mm

Reference Value = 8.33 V/m; Power Drift = 0.064 dB

Peak SAR (extrapolated) = 0.590 W/kg

SAR(1 g) = 0.188 mW/g; SAR(10 g) = 0.077 mW/g

Maximum value of SAR (measured) = 0.351 mW/g

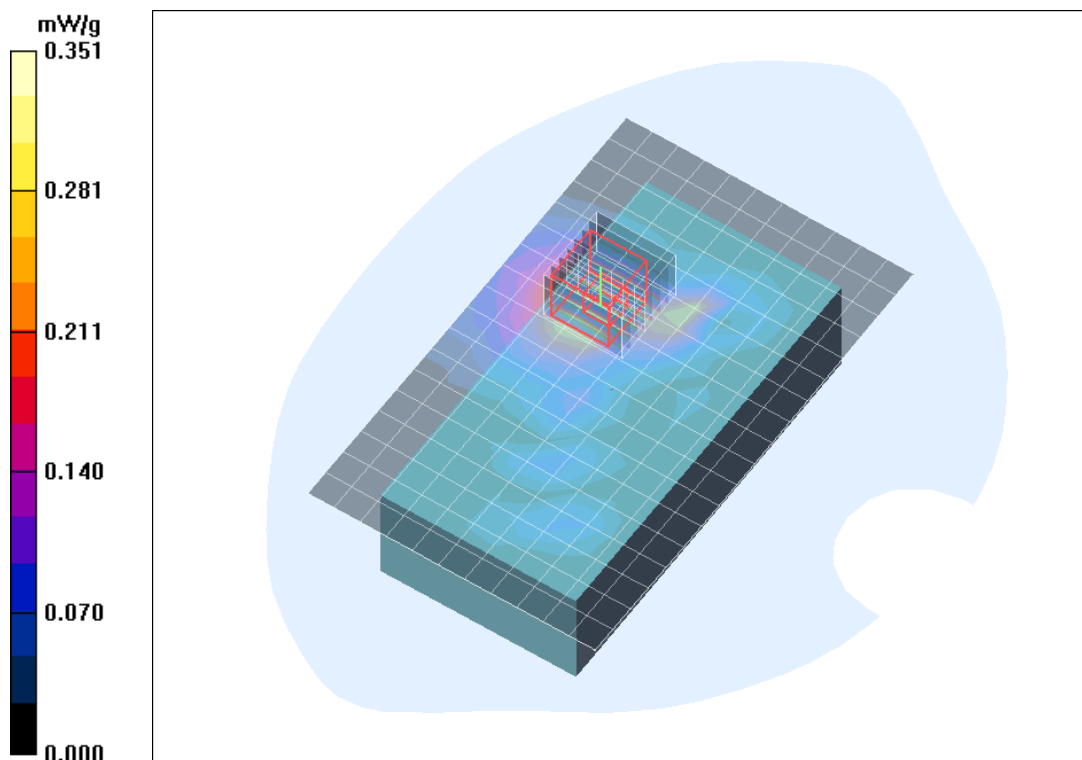

Fig. 10: SAR distribution for IEEE 802.11 a, channel 136, body worn configuration, display towards the ground, 0 mm distance (April 13, 2011; Ambient Temperature: 22.0° C; Liquid Temperature: 21.6° C).

5 SAR Distribution Plots, IEEE 802.11 a (5800 MHz Range)

Test Laboratory: IMST GmbH, DASY Blue (I); File Name: [Joya_bwhm_ch149_dspl_down.da4](#)

DUT: Datalogic; Type: Joya+ A; Serial: D10P00437

Program Name: WiFi 5800 MHz

Communication System: 5 GHz ; Frequency: 5745 MHz; Duty Cycle: 1:1

Medium parameters used: $f = 5745$ MHz; $\sigma = 6.1$ mho/m; $\epsilon_r = 47.7$; $\rho = 1000$ kg/m³

Phantom section: Flat Section

DASY4 Configuration:

- Probe: EX3DV4 - SN3536; ConvF(4.1, 4.1, 4.1); Calibrated: 16.09.2010

- Sensor-Surface: 2mm (Mechanical Surface Detection)

- Electronics: DAE4 Sn631; Calibrated: 17.09.2010

- Phantom: SAM Glycol 1176; Type: Speag; Serial: 1176

- Measurement SW: DASY4, V4.7 Build 80; Postprocessing SW: SEMCAD, V1.8 Build 186

Body Worn/Area Scan (12x19x1): Measurement grid: dx=10mm, dy=10mm

Maximum value of SAR (measured) = 0.345 mW/g

Body Worn/Zoom Scan (8x8x8)/Cube 0: Measurement grid: dx=4.3mm, dy=4.3mm, dz=3mm

Reference Value = 8.37 V/m; Power Drift = 0.260 dB

Peak SAR (extrapolated) = 0.562 W/kg

SAR(1 g) = 0.148 mW/g; SAR(10 g) = 0.054 mW/g

Maximum value of SAR (measured) = 0.359 mW/g

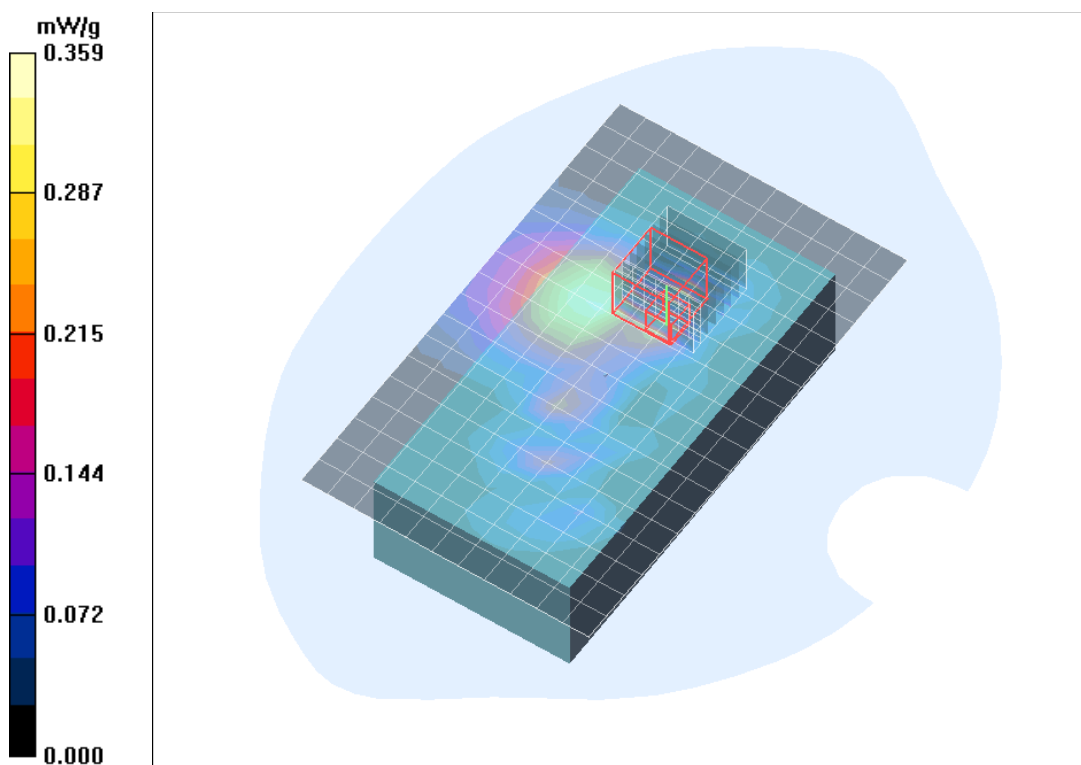

Fig. 11: SAR distribution for IEEE 802.11 a, channel 149, body worn configuration, display towards the ground, 0 mm distance (April 14, 2011; Ambient Temperature: 22.3° C; Liquid Temperature: 21.7° C).

Test Laboratory: IMST GmbH, DASY Blue (I); File Name: [Joya bwhm ch161 dspl down.da4](#)

DUT: Datalogic; Type: Joya+ A; Serial: D10P00437

Program Name: WiFi 5800 MHz

Communication System: 5 GHz ; Frequency: 5805 MHz; Duty Cycle: 1:1

Medium parameters used: $f = 5805$ MHz; $\sigma = 6.18$ mho/m; $\epsilon_r = 47.5$; $\rho = 1000$ kg/m³

Phantom section: Flat Section

DASY4 Configuration:

- Probe: EX3DV4 - SN3536; ConvF(4.1, 4.1, 4.1); Calibrated: 16.09.2010

- Sensor-Surface: 2mm (Mechanical Surface Detection)

- Electronics: DAE4 Sn631; Calibrated: 17.09.2010

- Phantom: SAM Glycol 1176; Type: Speag; Serial: 1176

- Measurement SW: DASY4, V4.7 Build 80; Postprocessing SW: SEMCAD, V1.8 Build 186

Body Worn/Area Scan (12x19x1): Measurement grid: dx=10mm, dy=10mm

Maximum value of SAR (measured) = 0.384 mW/g

Body Worn/Zoom Scan (8x8x8)/Cube 0: Measurement grid: dx=4.3mm, dy=4.3mm, dz=3mm

Reference Value = 8.87 V/m; Power Drift = 0.132 dB

Peak SAR (extrapolated) = 0.660 W/kg

SAR(1 g) = 0.169 mW/g; SAR(10 g) = 0.057 mW/g

Maximum value of SAR (measured) = 0.442 mW/g

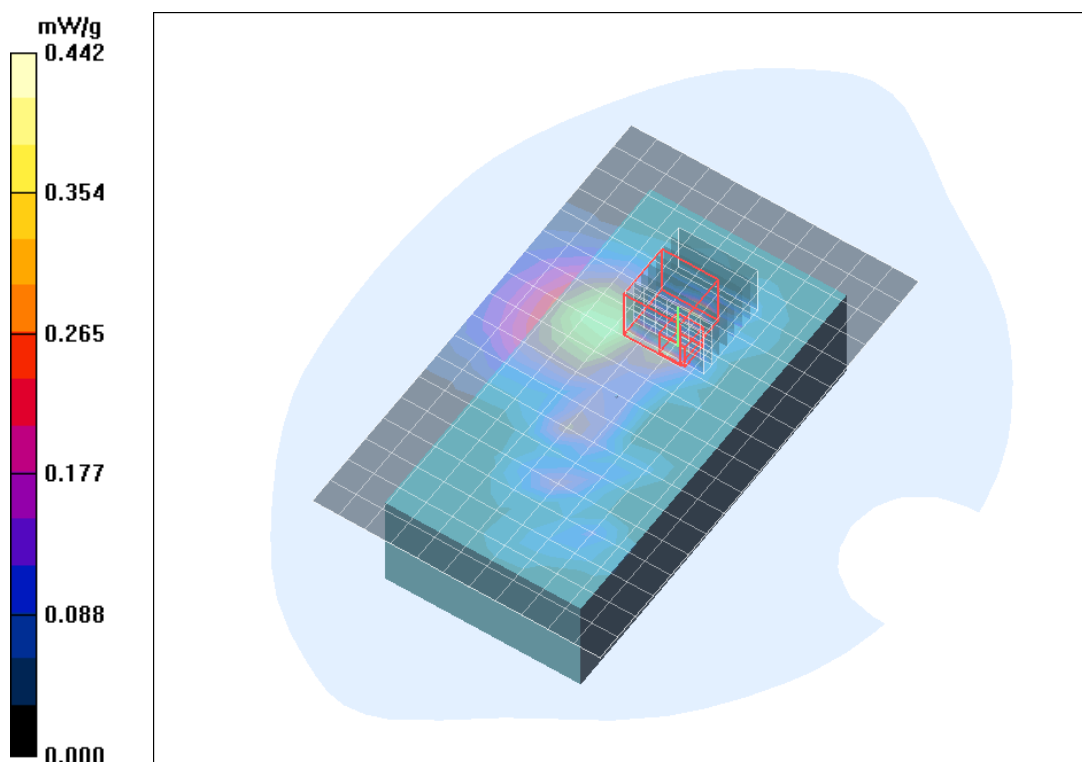

Fig. 12: SAR distribution for IEEE 802.11 a, channel 161, body worn configuration, display towards the ground, 0 mm distance (April 14, 2011; Ambient Temperature: 22.3° C; Liquid Temperature: 21.7° C).

6 SAR Z-axis Scans (Validation)

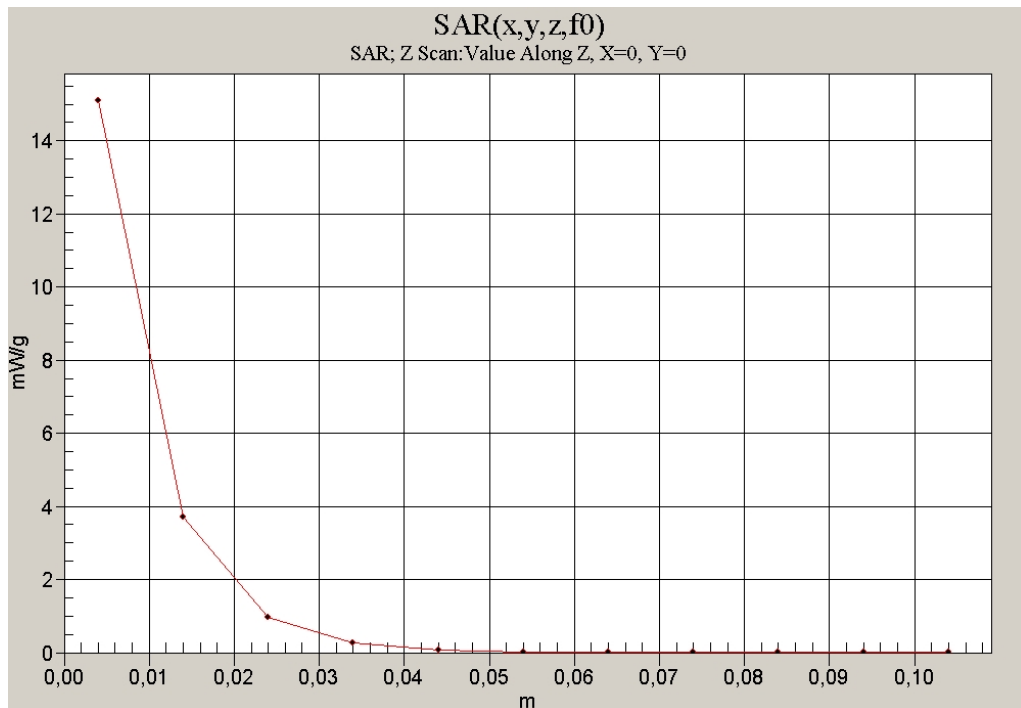

Fig. 13: SAR versus liquid depth, 2450 MHz, body (January 31, 2011; Ambient Temperature: 22.0° C; Liquid Temperature: 21.8° C).

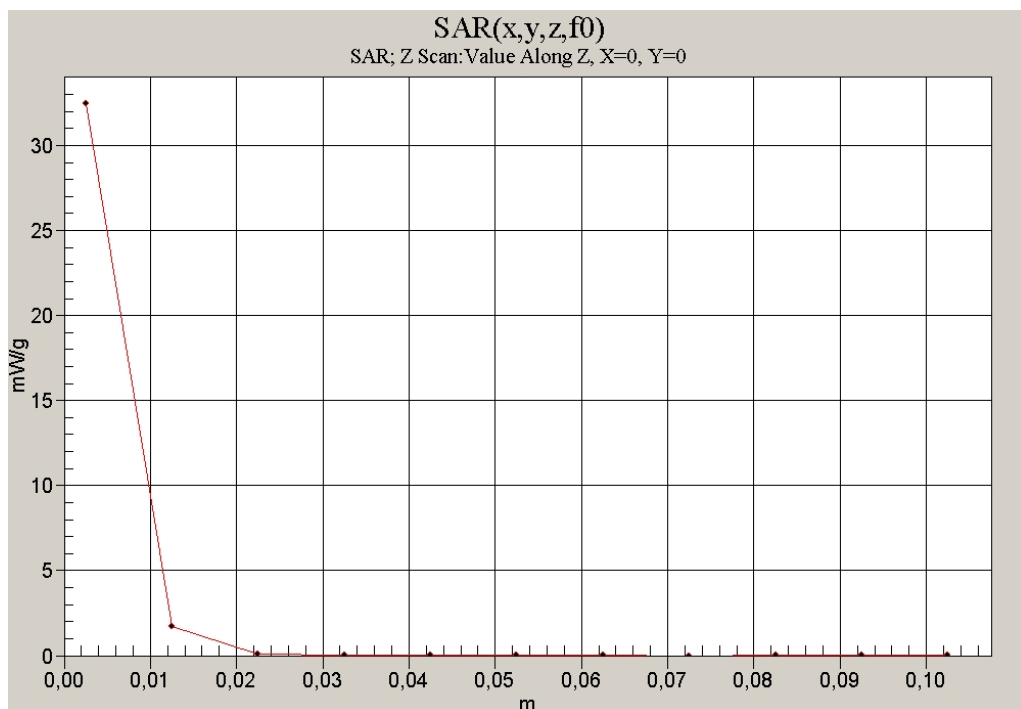

Fig. 14: SAR versus liquid depth, 5200 MHz, body (April 08, 2011; Ambient Temperature: 22.2° C; Liquid Temperature: 21.5° C).

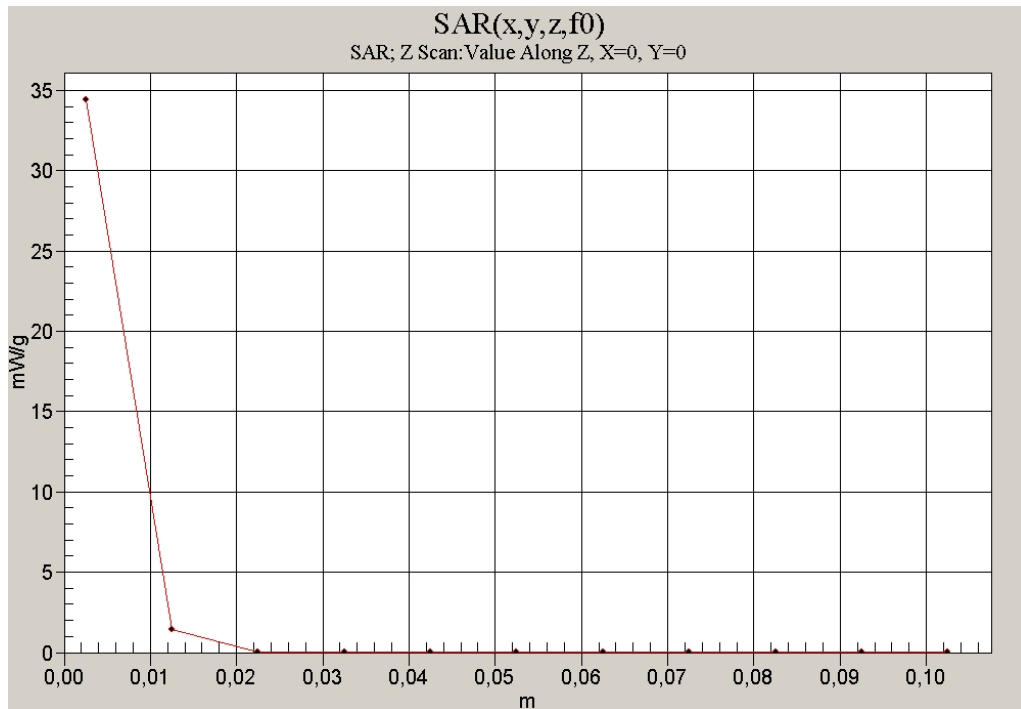

Fig. 15: SAR versus liquid depth, 5500 MHz, body (April 13, 2011; Ambient Temperature: 22.0° C; Liquid Temperature: 21.5° C).

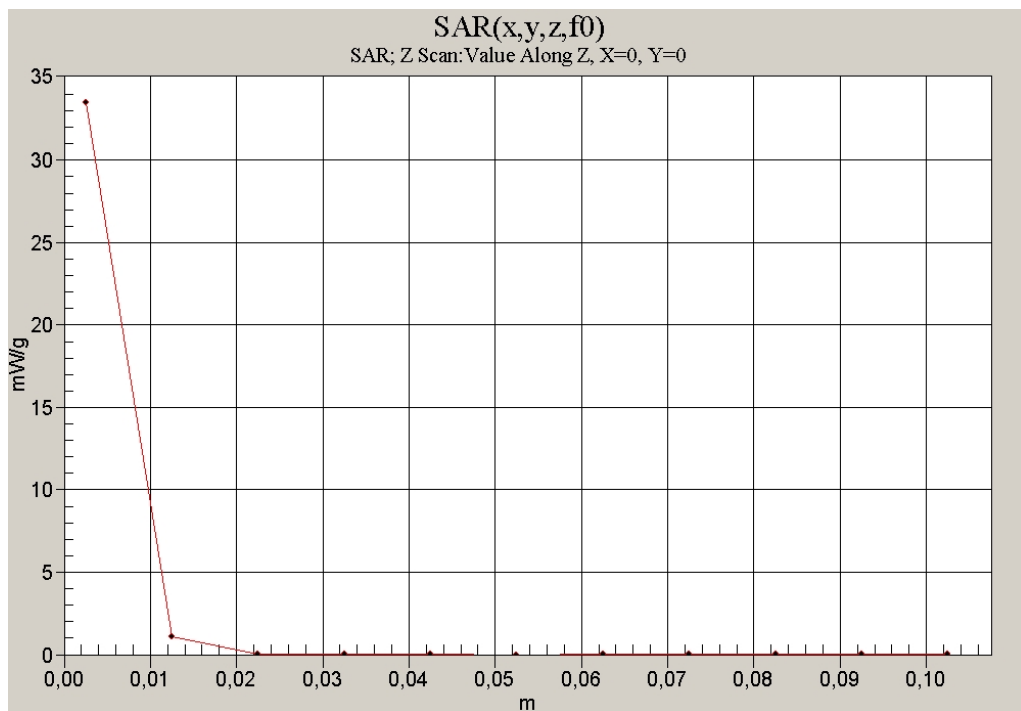

Fig. 16: SAR versus liquid depth, 5800 MHz, body (April 14, 2011; Ambient Temperature: 22.3° C; Liquid Temperature: 21.7° C).

7 SAR Z-axis Scans (Measurements)

The following pictures show the plots of SAR versus liquid depth for the worst case values.

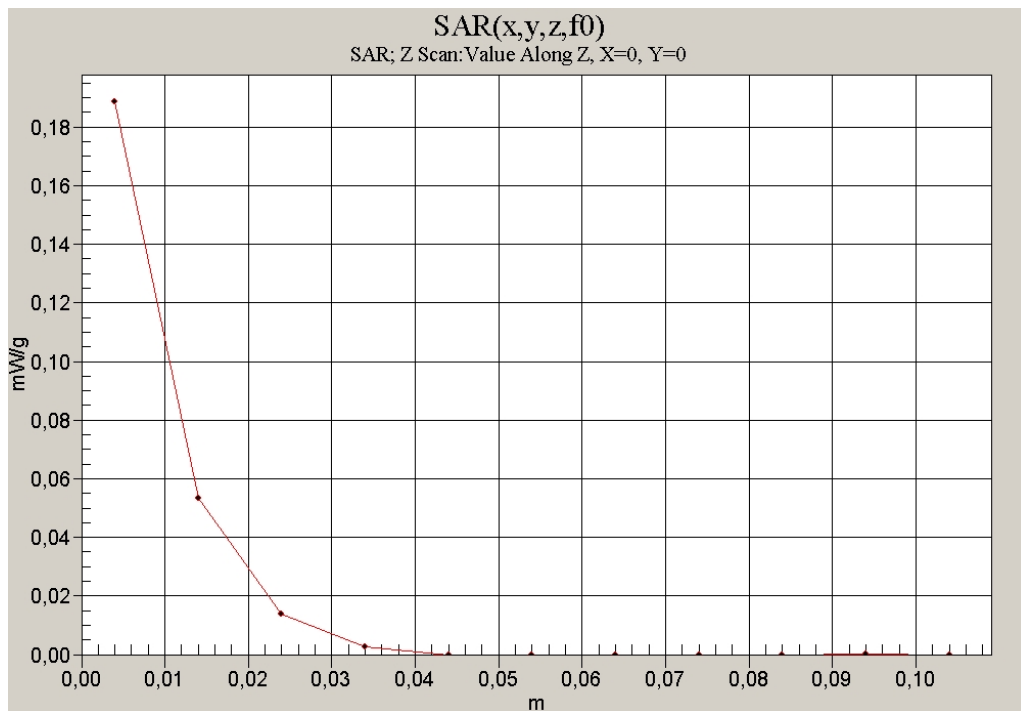

Fig. 17: SAR versus liquid depth, body: IEEE 802.11 g, channel 6, display towards the ground (January 31, 2011; Ambient Temperature: 22.0° C; Liquid Temperature: 21.8° C).

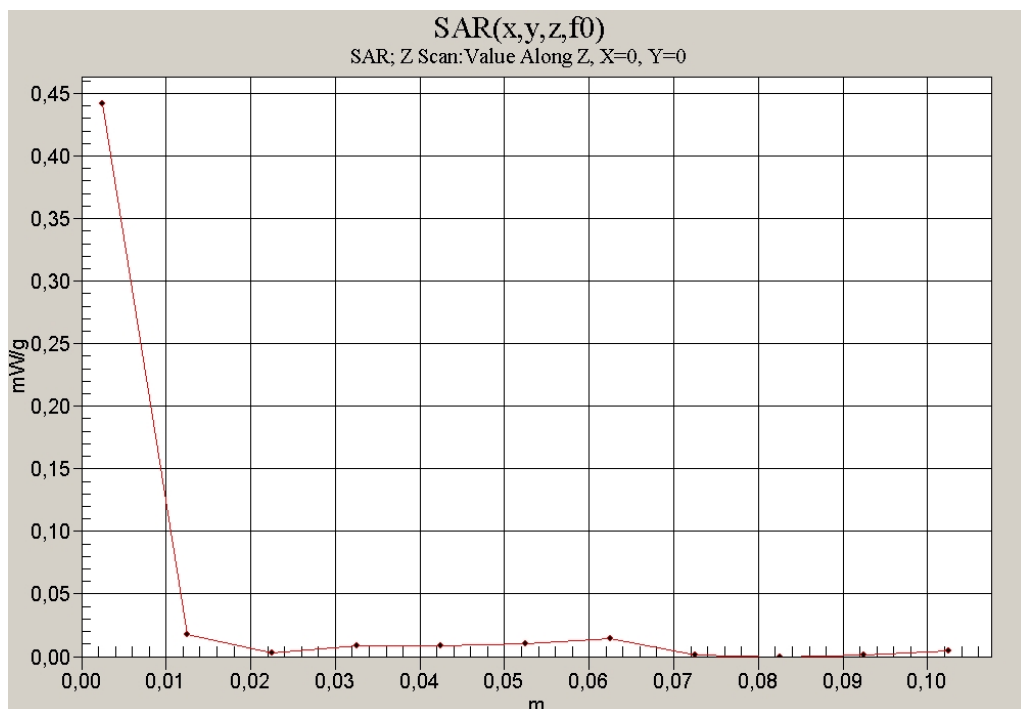

Fig. 18: SAR versus liquid depth, body: IEEE 802.11 a, channel 36, display towards the ground (April 08, 2011; Ambient Temperature: 22.2°C; Liquid Temperature: 21.5° C).