Appendix for the Report
Dosimetric Assessment of the
Datalogic ELF (FCC ID: U4G0040)
According to the FCC Requirements
SAR Distribution Plots

August 10, 2010
IMST GmbH
Carl-Friedrich-Gauß-Str. 2
D-47475 Kamp-Lintfort

Customer
7layers AG
Borsigstrasse 11
D-40880 Ratingen

The test results only relate to the items tested. This report shall not be reproduced except in full without the written approval of the testing laboratory.

Table of Contents

1	SAR DISTRIBUTION PLOTS, GSM 850 HEAD.....	3
2	SAR DISTRIBUTION PLOTS, GSM / GPRS / EDGE 850 BODY	7
3	SAR DISTRIBUTION PLOTS, PCS 1900 HEAD	12
4	SAR DISTRIBUTION PLOTS, PCS / GPRS / EDGE 1900 BODY	16
5	SAR DISTRIBUTION PLOTS, WCDMA V (FDD) HEAD.....	21
6	SAR DISTRIBUTION PLOTS, WCDMA V (FDD) BODY	25
7	SAR DISTRIBUTION PLOTS, WCDMA II (FDD) HEAD	29
8	SAR DISTRIBUTION PLOTS, WCDMA II (FDD) BODY	35
9	SAR DISTRIBUTION PLOTS, IEEE 802.11 B HEAD	39
10	SAR DISTRIBUTION PLOTS, IEEE 802.11 B BODY	43
11	SAR DISTRIBUTION PLOTS, IEEE 802.11 G HEAD.....	45
12	SAR DISTRIBUTION PLOTS, IEEE 802.11 G BODY.....	49
13	SAR DISTRIBUTION PLOTS, IEEE 802.11 A HEAD (5200 MHZ RANGE)	51
14	SAR DISTRIBUTION PLOTS, IEEE 802.11 A BODY (5200 MHZ RANGE).....	61
15	SAR DISTRIBUTION PLOTS, IEEE 802.11 A HEAD (5500 MHZ RANGE)	69
16	SAR DISTRIBUTION PLOTS, IEEE 802.11 A BODY (5500 MHZ RANGE).....	79
17	SAR DISTRIBUTION PLOTS, IEEE 802.11 A HEAD (5800 MHZ RANGE)	87
18	SAR DISTRIBUTION PLOTS, IEEE 802.11 A BODY (5800 MHZ RANGE).....	93
19	SAR Z-AXIS SCANS (VALIDATION)	97
20	SAR Z-AXIS SCANS (MEASUREMENTS).....	103

1 SAR Distribution Plots, GSM 850 Head

Test Laboratory: IMST GmbH, DASY Blue (I); File Name: [680_balm_1.da4](#)

DUT: Datalogic ; Type: ELF; Serial: 354114011832680

Program Name: GSM 850

Communication System: GSM 850; Frequency: 836.6 MHz; Duty Cycle: 1:8.3

Medium parameters used: $f = 836.6$ MHz; $\sigma = 0.92$ mho/m; $\epsilon_r = 39.6$; $\rho = 1000$ kg/m³

Phantom section: Left Section

DASY4 Configuration:

- Probe: ET3DV6R - SN1579; ConvF(6.34, 6.34, 6.34); Calibrated: 20.01.2010

- Sensor-Surface: 4mm (Mechanical Surface Detection)

- Electronics: DAE4 Sn631; Calibrated: 14.09.2009

- Phantom: SAM Sugar 1059; Type: Speag; Serial: 1059

- Measurement SW: DASY4, V4.7 Build 80; Postprocessing SW: SEMCAD, V1.8 Build 186

Cheek Left/Area Scan (9x14x1): Measurement grid: dx=15mm, dy=15mm

Maximum value of SAR (measured) = 0.635 mW/g

Cheek Left/Zoom Scan (7x7x7)/Cube 0: Measurement grid: dx=5mm, dy=5mm, dz=5mm

Reference Value = 21.4 V/m; Power Drift = -0.162 dB

Peak SAR (extrapolated) = 0.879 W/kg

SAR(1 g) = 0.595 mW/g; SAR(10 g) = 0.390 mW/g

Maximum value of SAR (measured) = 0.637 mW/g

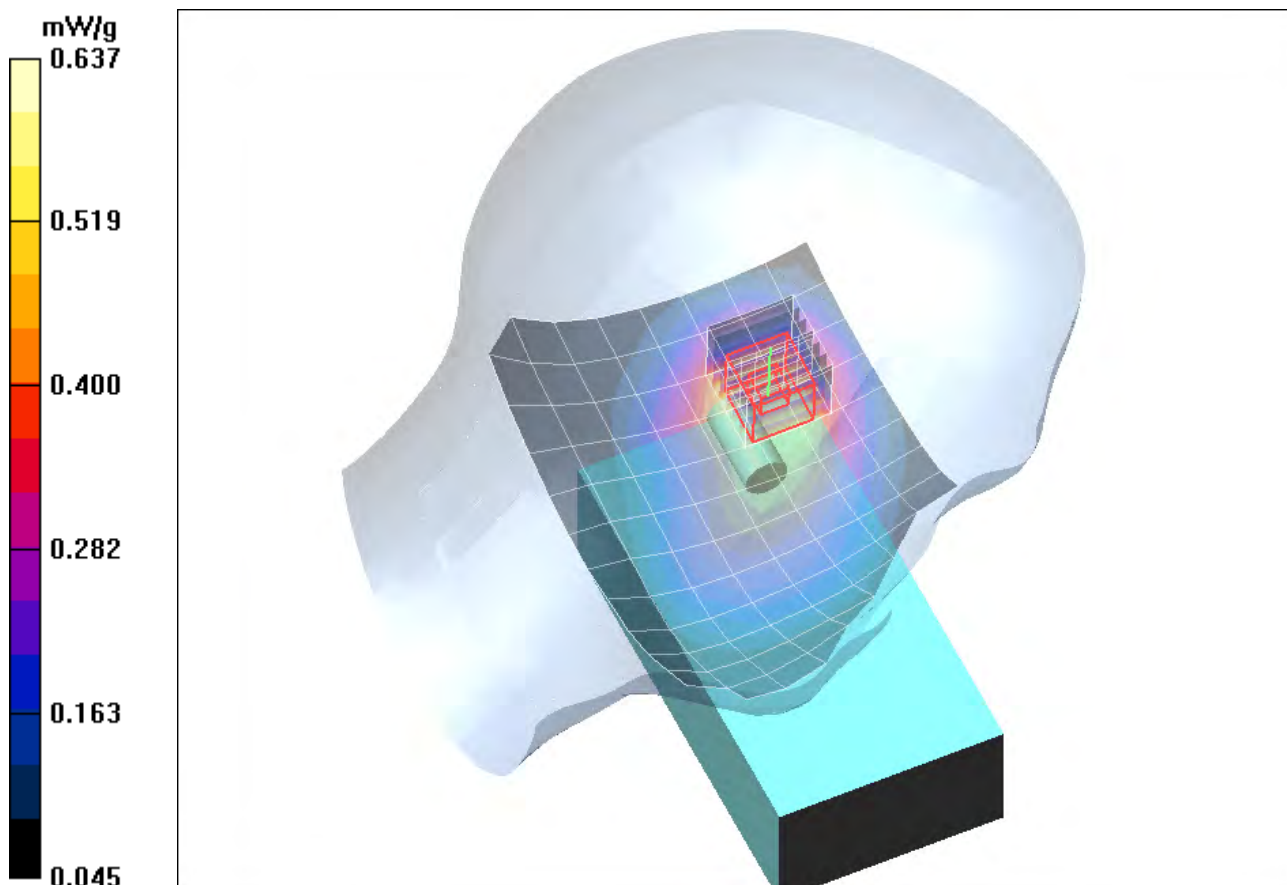

Fig. 1: SAR distribution for GSM 850, channel 190, cheek position, left side of head (July 20, 2010; Ambient Temperature: 21.1° C; Liquid Temperature: 20.6° C).

Test Laboratory: IMST GmbH, DASY Blue (I); File Name: [680 balm 2.da4](#)

DUT: Datalogic ; Type: ELF; Serial: 354114011832680

Program Name: GSM 850

Communication System: GSM 850; Frequency: 836.6 MHz; Duty Cycle: 1:8.3

Medium parameters used: $f = 836.6$ MHz; $\sigma = 0.92$ mho/m; $\epsilon_r = 39.6$; $\rho = 1000$ kg/m³

Phantom section: Left Section

DASY4 Configuration:

- Probe: ET3DV6R - SN1579; ConvF(6.34, 6.34, 6.34); Calibrated: 20.01.2010
- Sensor-Surface: 4mm (Mechanical Surface Detection)
- Electronics: DAE4 Sn631; Calibrated: 14.09.2009
- Phantom: SAM Sugar 1059; Type: Speag; Serial: 1059
- Measurement SW: DASY4, V4.7 Build 80; Postprocessing SW: SEMCAD, V1.8 Build 186

Tilted Left/Area Scan (9x14x1): Measurement grid: dx=15mm, dy=15mm

Maximum value of SAR (measured) = 0.687 mW/g

Tilted Left/Zoom Scan (7x7x7)/Cube 0: Measurement grid: dx=5mm, dy=5mm, dz=5mm

Reference Value = 22.5 V/m; Power Drift = 0.052 dB

Peak SAR (extrapolated) = 1.05 W/kg

SAR(1 g) = 0.701 mW/g; SAR(10 g) = 0.446 mW/g

Maximum value of SAR (measured) = 0.747 mW/g

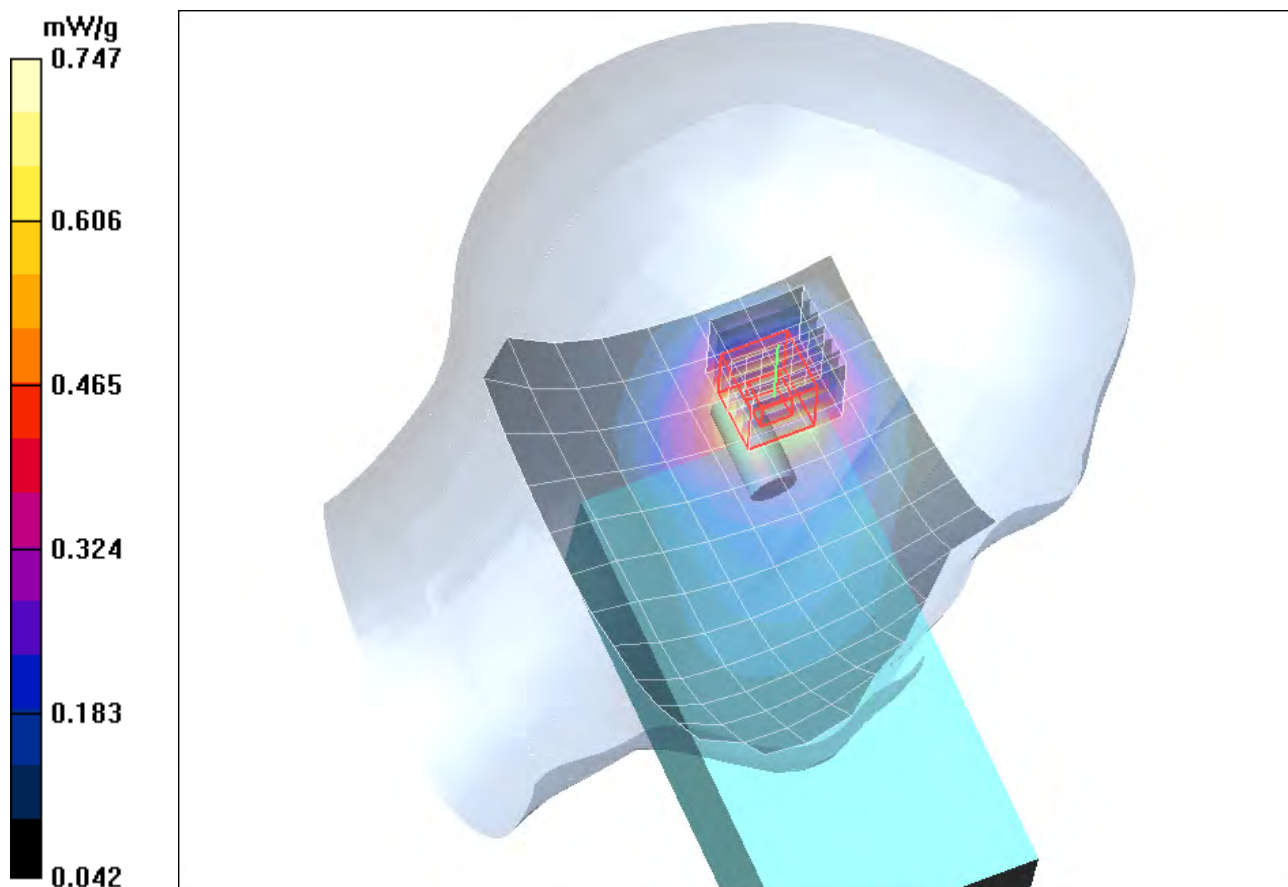

Fig. 2: SAR distribution for GSM 850, channel 190, tilted position, left side of head (July 20, 2010; Ambient Temperature: 21.1° C; Liquid Temperature: 20.6° C).

Test Laboratory: IMST GmbH, DASY Blue (I); File Name: [680_barm_1.da4](#)

DUT: Datalogic ; Type: ELF; Serial: 354114011832680

Program Name: GSM 850

Communication System: GSM 850; Frequency: 836.6 MHz; Duty Cycle: 1:8.3

Medium parameters used: $f = 836.6$ MHz; $\sigma = 0.92$ mho/m; $\epsilon_r = 39.6$; $\rho = 1000$ kg/m³

Phantom section: Right Section

DASY4 Configuration:

- Probe: ET3DV6R - SN1579; ConvF(6.34, 6.34, 6.34); Calibrated: 20.01.2010
- Sensor-Surface: 4mm (Mechanical Surface Detection)
- Electronics: DAE4 Sn631; Calibrated: 14.09.2009
- Phantom: SAM Sugar 1059; Type: Speag; Serial: 1059
- Measurement SW: DASY4, V4.7 Build 80; Postprocessing SW: SEMCAD, V1.8 Build 186

Cheek Right/Area Scan (9x14x1): Measurement grid: dx=15mm, dy=15mm

Maximum value of SAR (measured) = 0.471 mW/g

Cheek Right/Zoom Scan (7x7x7)/Cube 0: Measurement grid: dx=5mm, dy=5mm, dz=5mm

Reference Value = 23.8 V/m; Power Drift = -0.043 dB

Peak SAR (extrapolated) = 0.621 W/kg

SAR(1 g) = 0.453 mW/g; SAR(10 g) = 0.320 mW/g

Maximum value of SAR (measured) = 0.482 mW/g

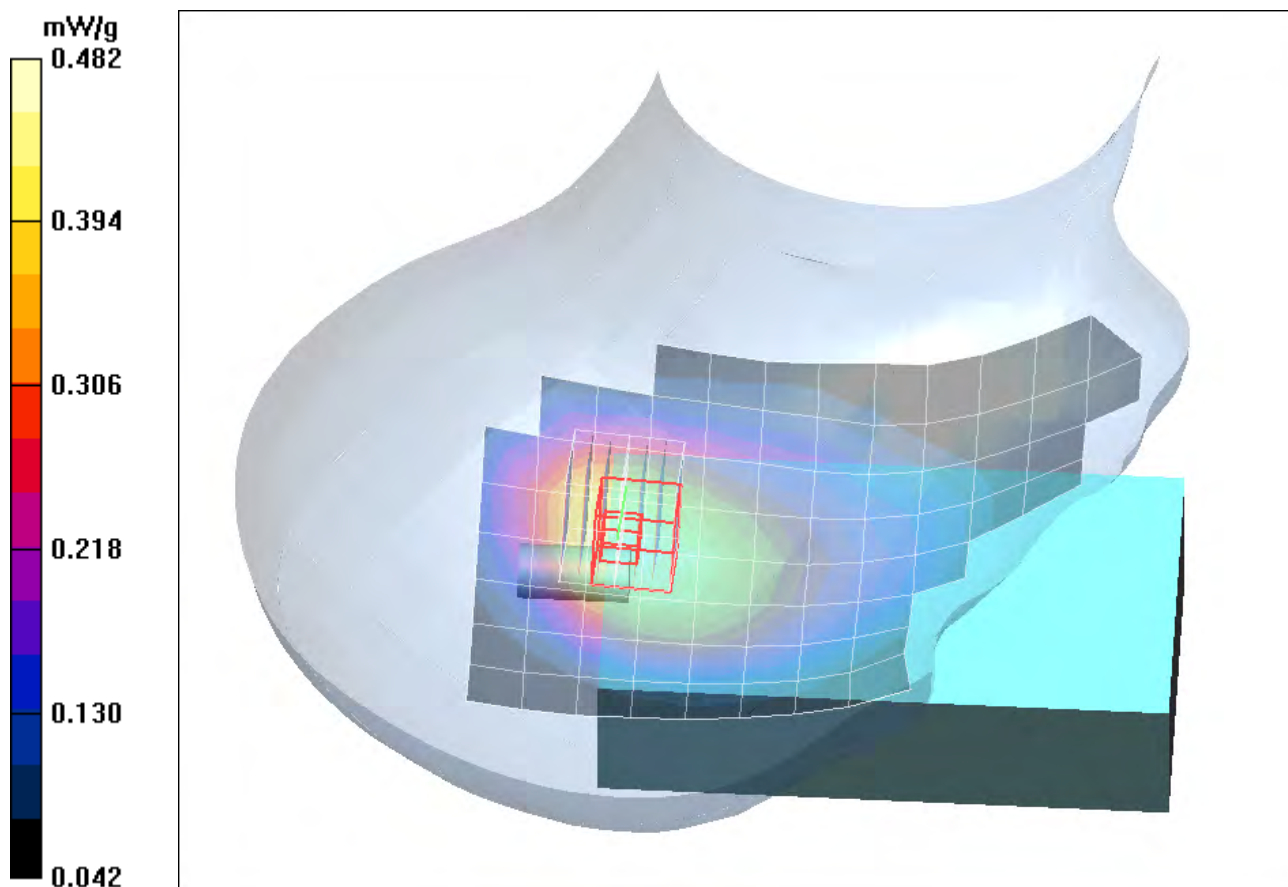

Fig. 3: SAR distribution for GSM 850, channel 190, cheek position, right side of head (July 20, 2010; Ambient Temperature: 21.1° C; Liquid Temperature: 20.6° C).

Test Laboratory: IMST GmbH, DASY Blue (I); File Name: [680_barm_2.da4](#)

DUT: Datalogic ; Type: ELF; Serial: 354114011832680

Program Name: GSM 850

Communication System: GSM 850; Frequency: 836.6 MHz; Duty Cycle: 1:8.3

Medium parameters used: $f = 836.6$ MHz; $\sigma = 0.92$ mho/m; $\epsilon_r = 39.6$; $\rho = 1000$ kg/m³

Phantom section: Right Section

DASY4 Configuration:

- Probe: ET3DV6R - SN1579; ConvF(6.34, 6.34, 6.34); Calibrated: 20.01.2010
- Sensor-Surface: 4mm (Mechanical Surface Detection)
- Electronics: DAE4 Sn631; Calibrated: 14.09.2009
- Phantom: SAM Sugar 1059; Type: Speag; Serial: 1059
- Measurement SW: DASY4, V4.7 Build 80; Postprocessing SW: SEMCAD, V1.8 Build 186

Tilted Right/Area Scan (9x14x1): Measurement grid: dx=15mm, dy=15mm

Maximum value of SAR (measured) = 0.564 mW/g

Tilted Right/Zoom Scan (7x7x7)/Cube 0: Measurement grid: dx=5mm, dy=5mm, dz=5mm

Reference Value = 24.6 V/m; Power Drift = -0.082 dB

Peak SAR (extrapolated) = 0.763 W/kg

SAR(1 g) = 0.542 mW/g; SAR(10 g) = 0.364 mW/g

Maximum value of SAR (measured) = 0.579 mW/g

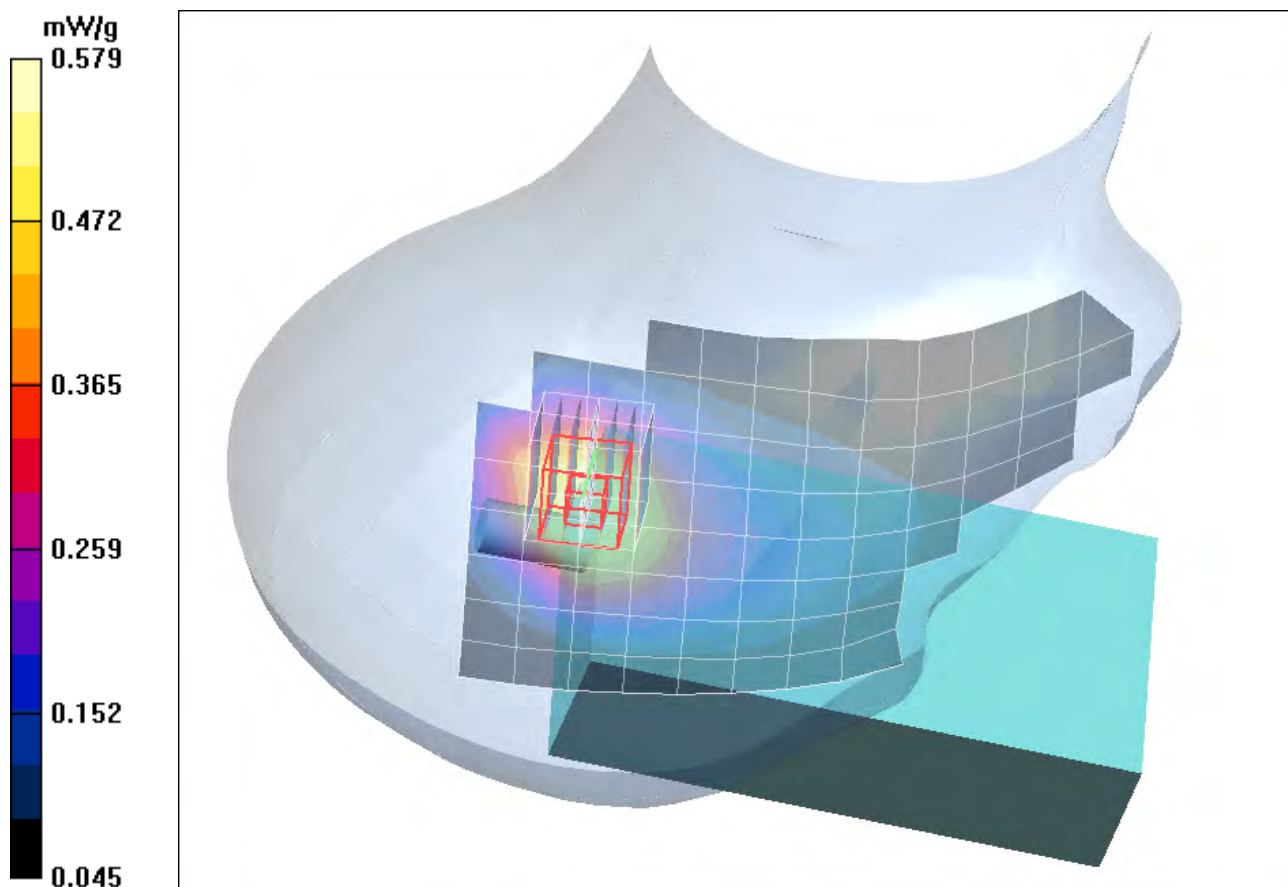

Fig. 4: SAR distribution for GSM 850, channel 190, tilted position, right side of head (July 20, 2010; Ambient Temperature: 21.1° C; Liquid Temperature: 20.6° C).

2 SAR Distribution Plots, GSM / GPRS / EDGE 850 Body

Test Laboratory: IMST GmbH, DASY Blue (I); File Name: [680_bahm_1_dspl_up_gprs_15mm.da4](#)

DUT: Datalogic ; Type: ELF; Serial: 354114011832680

Program Name: GPRS 850

Communication System: GPRS 850; Frequency: 836.6 MHz; Duty Cycle: 1:4

Medium parameters used: $f = 836.6$ MHz; $\sigma = 0.99$ mho/m; $\epsilon_r = 53.3$; $\rho = 1000$ kg/m³

Phantom section: Flat Section

DASY4 Configuration:

- Probe: ET3DV6R - SN1579; ConvF(6.21, 6.21, 6.21); Calibrated: 20.01.2010

- Sensor-Surface: 4mm (Mechanical Surface Detection)

- Electronics: DAE4 Sn631; Calibrated: 14.09.2009

- Phantom: SAM Sugar 1059; Type: Speag; Serial: 1059

- Measurement SW: DASY4, V4.7 Build 80; Postprocessing SW: SEMCAD, V1.8 Build 186

Body Worn/Area Scan (10x15x1): Measurement grid: dx=15mm, dy=15mm

Maximum value of SAR (measured) = 0.541 mW/g

Body Worn/Zoom Scan (7x7x7)/Cube 0: Measurement grid: dx=5mm, dy=5mm, dz=5mm

Reference Value = 21.6 V/m; Power Drift = -0.091 dB

Peak SAR (extrapolated) = 0.665 W/kg

SAR(1 g) = 0.530 mW/g; SAR(10 g) = 0.396 mW/g

Maximum value of SAR (measured) = 0.557 mW/g

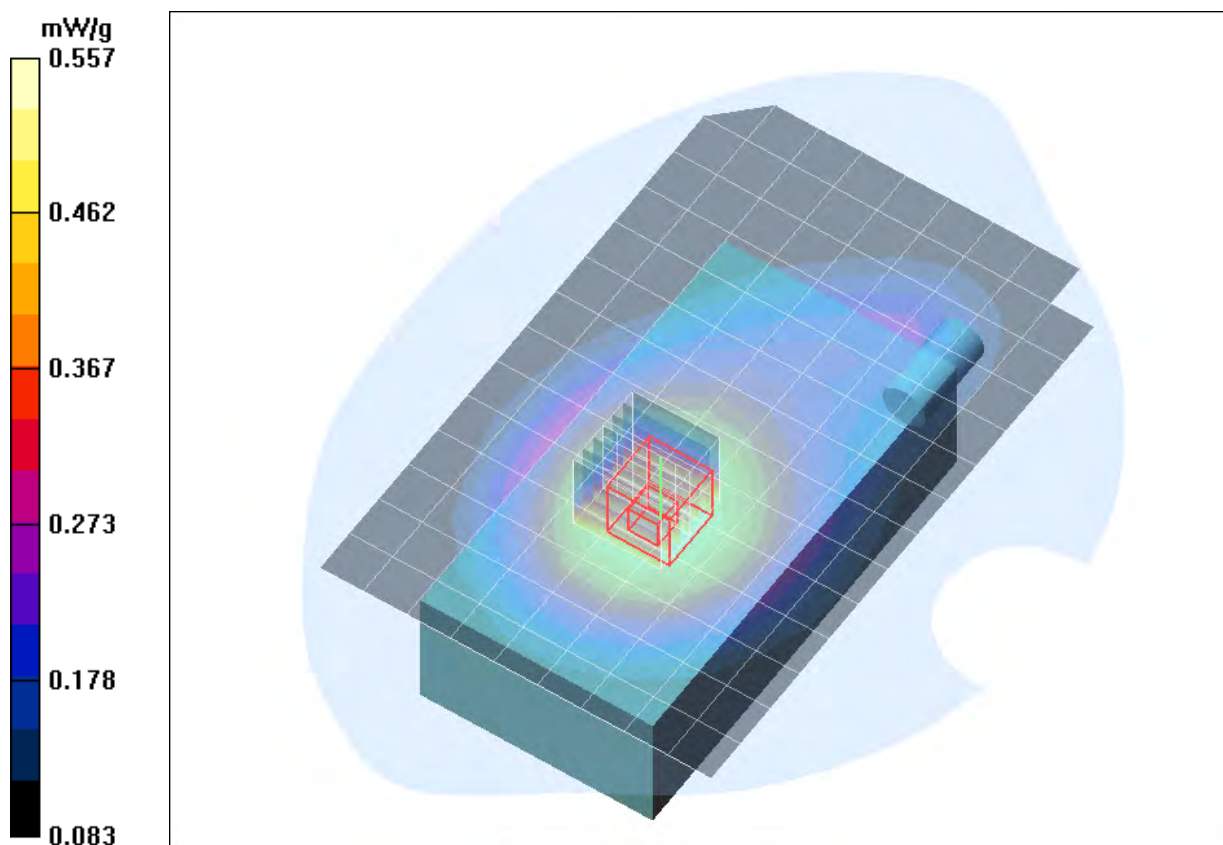

Fig. 5: SAR distribution for GPRS 850 (Class 10), channel 190, body worn configuration, display towards the phantom, 15 mm distance (July 26, 2010; Ambient Temperature: 21.3° C; Liquid Temperature: 20.7° C).

Test Laboratory: IMST GmbH, DASY Blue (I); File Name: [680_bahm_1_dspl_down_gprs_15mm.da4](#)

DUT: Datalogic ; Type: ELF; Serial: 354114011832680

Program Name: GPRS 850

Communication System: GPRS 850; Frequency: 836.6 MHz; Duty Cycle: 1:4

Medium parameters used: $f = 836.6$ MHz; $\sigma = 0.99$ mho/m; $\epsilon_r = 53.3$; $\rho = 1000$ kg/m³

Phantom section: Flat Section

DASY4 Configuration:

- Probe: ET3DV6R - SN1579; ConvF(6.21, 6.21, 6.21); Calibrated: 20.01.2010
- Sensor-Surface: 4mm (Mechanical Surface Detection)
- Electronics: DAE4 Sn631; Calibrated: 14.09.2009
- Phantom: SAM Sugar 1059; Type: Speag; Serial: 1059
- Measurement SW: DASY4, V4.7 Build 80; Postprocessing SW: SEMCAD, V1.8 Build 186

Body Worn/Area Scan (10x15x1): Measurement grid: dx=15mm, dy=15mm

Maximum value of SAR (measured) = 0.385 mW/g

Body Worn/Zoom Scan (7x7x7)/Cube 0: Measurement grid: dx=5mm, dy=5mm, dz=5mm

Reference Value = 17.4 V/m; Power Drift = -0.045 dB

Peak SAR (extrapolated) = 0.475 W/kg

SAR(1 g) = 0.371 mW/g; SAR(10 g) = 0.272 mW/g

Maximum value of SAR (measured) = 0.392 mW/g

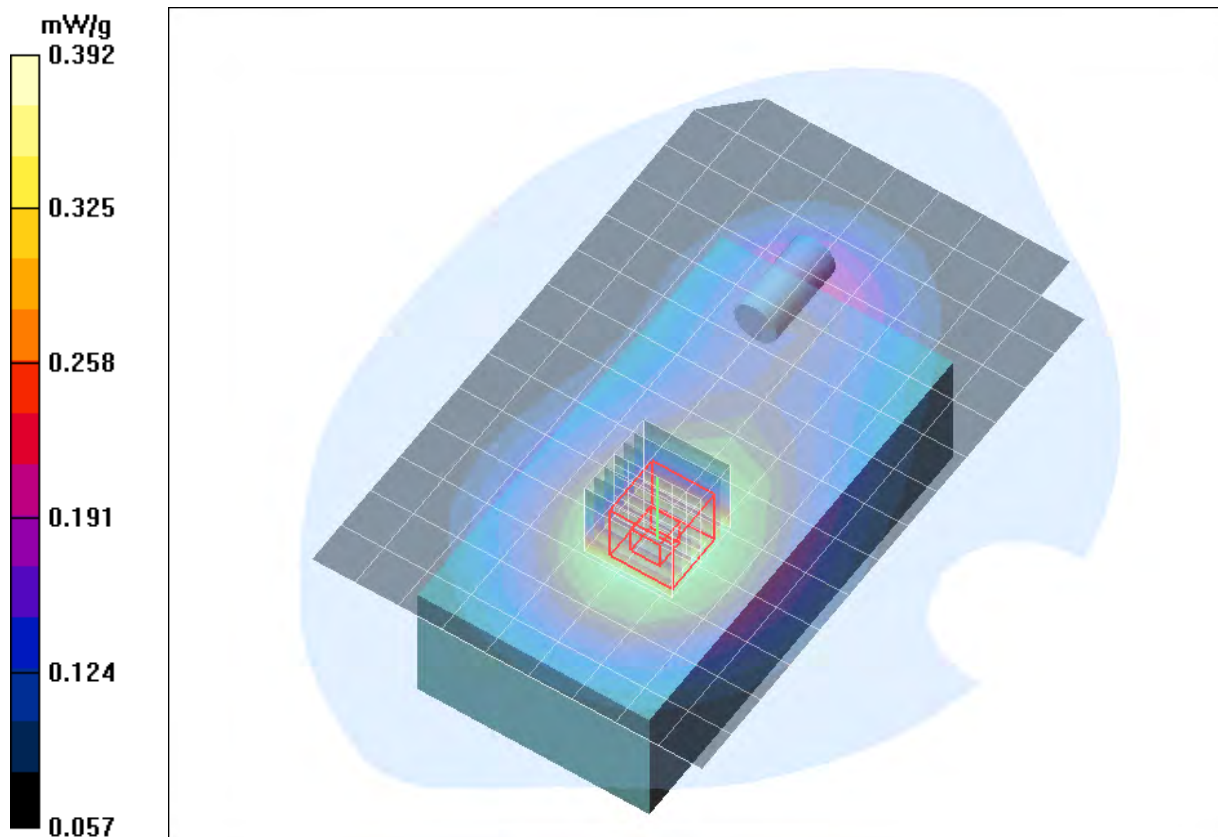

Fig. 6: SAR distribution for GPRS 850 (Class 10), channel 190, body worn configuration, display towards the ground, 15 mm distance (July 26, 2010; Ambient Temperature: 21.3° C; Liquid Temperature: 20.7° C).

Test Laboratory: IMST GmbH, DASY Blue (I); File Name: [680_bahm_2_dspl_up_HS_15mm.da4](#)

DUT: Datalogic ; Type: ELF; Serial: 354114011832680

Program Name: GSM 850

Communication System: GSM 850; Frequency: 836.6 MHz; Duty Cycle: 1:8.3

Medium parameters used: $f = 836.6$ MHz; $\sigma = 0.99$ mho/m; $\epsilon_r = 53.3$; $\rho = 1000$ kg/m³

Phantom section: Flat Section

DASY4 Configuration:

- Probe: ET3DV6R - SN1579; ConvF(6.21, 6.21, 6.21); Calibrated: 20.01.2010
- Sensor-Surface: 4mm (Mechanical Surface Detection)
- Electronics: DAE4 Sn631; Calibrated: 14.09.2009
- Phantom: SAM Sugar 1059; Type: Speag; Serial: 1059
- Measurement SW: DASY4, V4.7 Build 80; Postprocessing SW: SEMCAD, V1.8 Build 186

Body Worn/Area Scan (10x15x1): Measurement grid: dx=15mm, dy=15mm

Maximum value of SAR (measured) = 0.374 mW/g

Body Worn/Zoom Scan (7x7x7)/Cube 0: Measurement grid: dx=5mm, dy=5mm, dz=5mm

Reference Value = 17.8 V/m; Power Drift = -0.015 dB

Peak SAR (extrapolated) = 0.461 W/kg

SAR(1 g) = 0.366 mW/g; SAR(10 g) = 0.273 mW/g

Maximum value of SAR (measured) = 0.385 mW/g

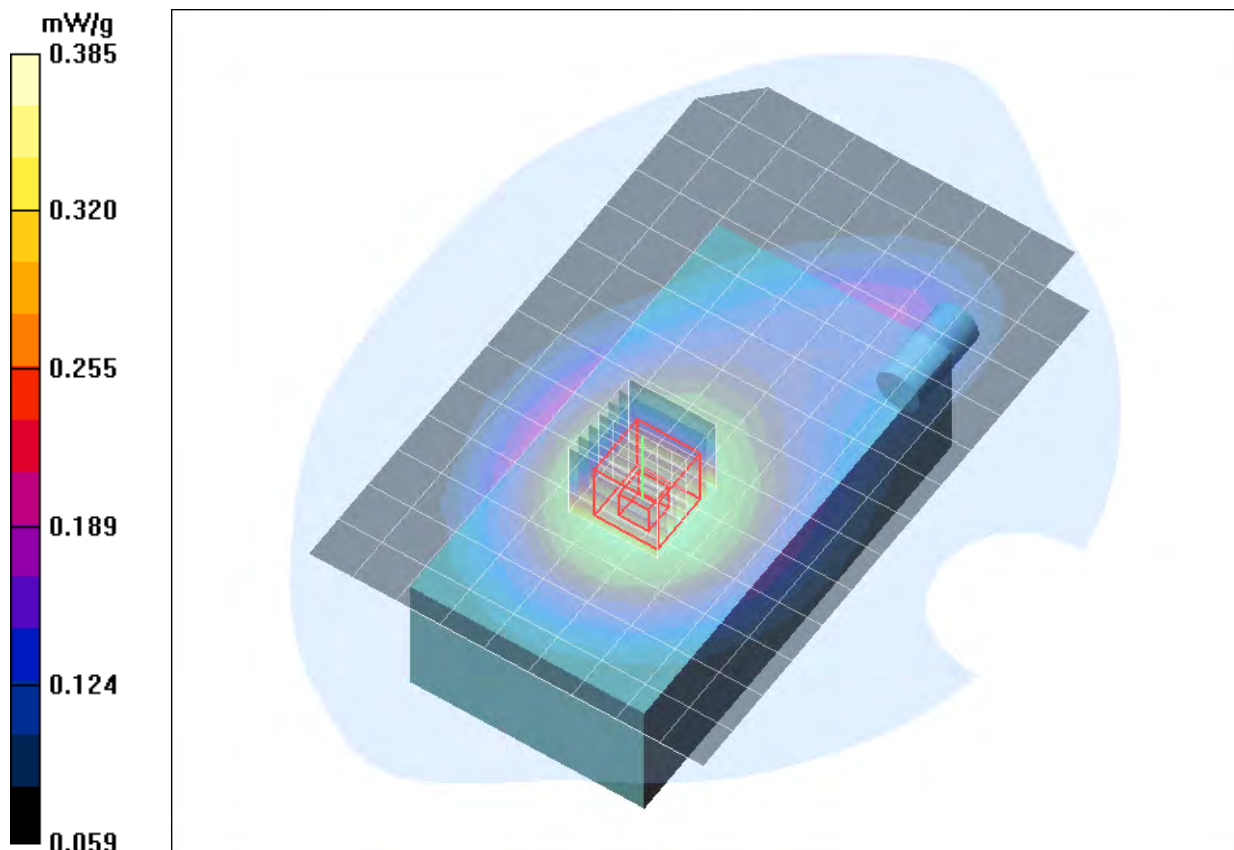

Fig. 7: SAR distribution for GSM 850, channel 190, body worn configuration, display towards the phantom, headset attached, 15 mm distance (July 26, 2010; Ambient Temperature: 21.3° C; Liquid Temperature: 20.7° C).

Test Laboratory: IMST GmbH, DASY Blue (I); File Name: [680_bahm_2_dspl_down_HS_15mm.da4](#)

DUT: Datalogic ; Type: ELF; Serial: 354114011832680

Program Name: GSM 850

Communication System: GSM 850; Frequency: 836.6 MHz; Duty Cycle: 1:8.3

Medium parameters used: $f = 836.6$ MHz; $\sigma = 0.99$ mho/m; $\epsilon_r = 53.3$; $\rho = 1000$ kg/m³

Phantom section: Flat Section

DASY4 Configuration:

- Probe: ET3DV6R - SN1579; ConvF(6.21, 6.21, 6.21); Calibrated: 20.01.2010
- Sensor-Surface: 4mm (Mechanical Surface Detection)
- Electronics: DAE4 Sn631; Calibrated: 14.09.2009
- Phantom: SAM Sugar 1059; Type: Speag; Serial: 1059
- Measurement SW: DASY4, V4.7 Build 80; Postprocessing SW: SEMCAD, V1.8 Build 186

Body Worn/Area Scan (10x15x1): Measurement grid: dx=15mm, dy=15mm

Maximum value of SAR (measured) = 0.286 mW/g

Body Worn/Zoom Scan (7x7x7)/Cube 0: Measurement grid: dx=5mm, dy=5mm, dz=5mm

Reference Value = 14.9 V/m; Power Drift = 0.013 dB

Peak SAR (extrapolated) = 0.350 W/kg

SAR(1 g) = 0.269 mW/g; SAR(10 g) = 0.197 mW/g

Maximum value of SAR (measured) = 0.284 mW/g

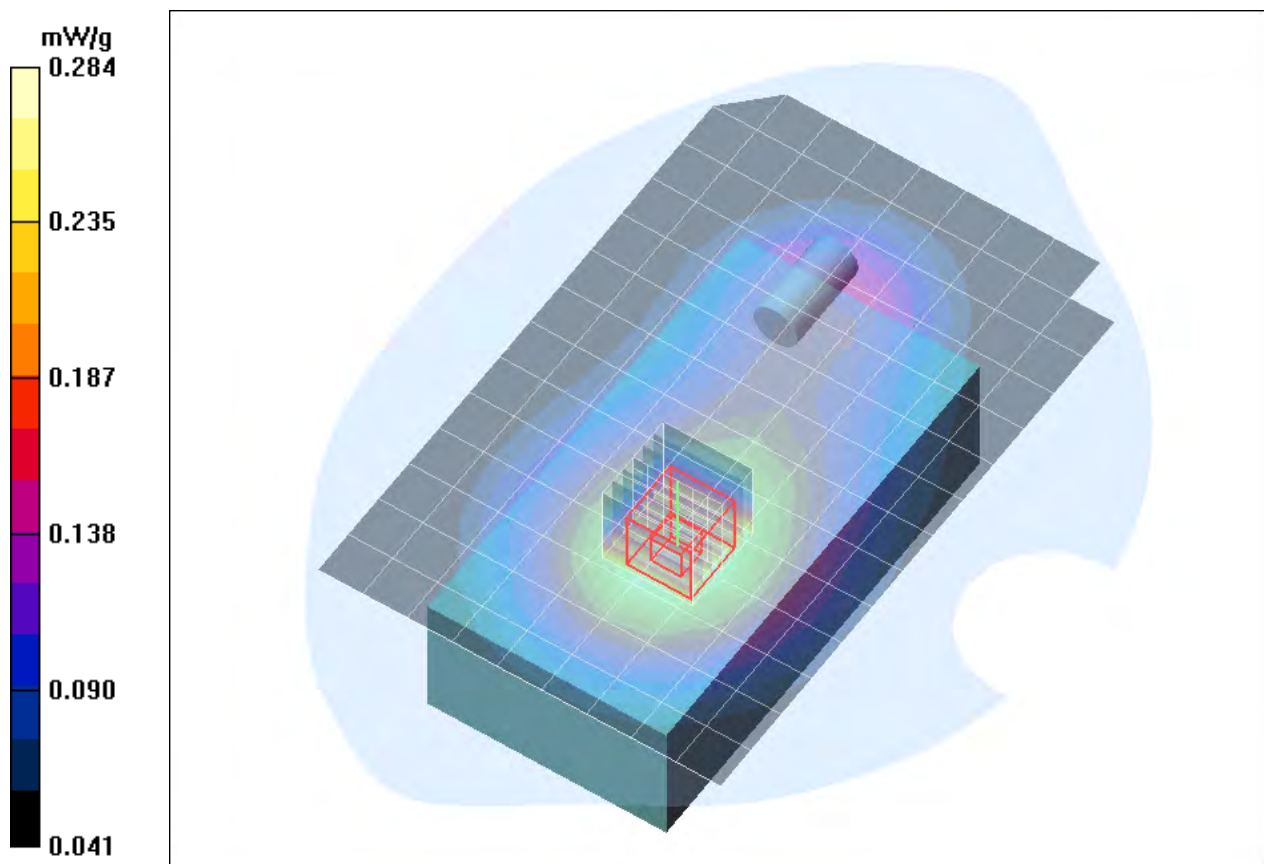

Fig. 8: SAR distribution for GSM 850, channel 190, body worn configuration, display towards the ground, headset attached, 15 mm distance (July 26, 2010; Ambient Temperature: 21.3° C; Liquid Temperature: 20.7° C).

Test Laboratory: IMST GmbH, DASY Blue (I); File Name: [680_bahm_1_dspl_up_edge_15mm.da4](#)

DUT: Datalogic ; Type: ELF; Serial: 354114011832680

Program Name: EDGE 850

Communication System: EDGE 850; Frequency: 836.6 MHz; Duty Cycle: 1:4

Medium parameters used: $f = 836.6$ MHz; $\sigma = 0.99$ mho/m; $\epsilon_r = 53.3$; $\rho = 1000$ kg/m³

Phantom section: Flat Section

DASY4 Configuration:

- Probe: ET3DV6R - SN1579; ConvF(6.21, 6.21, 6.21); Calibrated: 20.01.2010
- Sensor-Surface: 4mm (Mechanical Surface Detection)
- Electronics: DAE4 Sn631; Calibrated: 14.09.2009
- Phantom: SAM Sugar 1059; Type: Speag; Serial: 1059
- Measurement SW: DASY4, V4.7 Build 80; Postprocessing SW: SEMCAD, V1.8 Build 186

Body Worn/Area Scan (10x15x1): Measurement grid: dx=15mm, dy=15mm

Maximum value of SAR (measured) = 0.540 mW/g

Body Worn/Zoom Scan (7x7x7)/Cube 0: Measurement grid: dx=5mm, dy=5mm, dz=5mm

Reference Value = 22.3 V/m; Power Drift = -0.134 dB

Peak SAR (extrapolated) = 0.650 W/kg

SAR(1 g) = 0.514 mW/g; SAR(10 g) = 0.385 mW/g

Maximum value of SAR (measured) = 0.542 mW/g

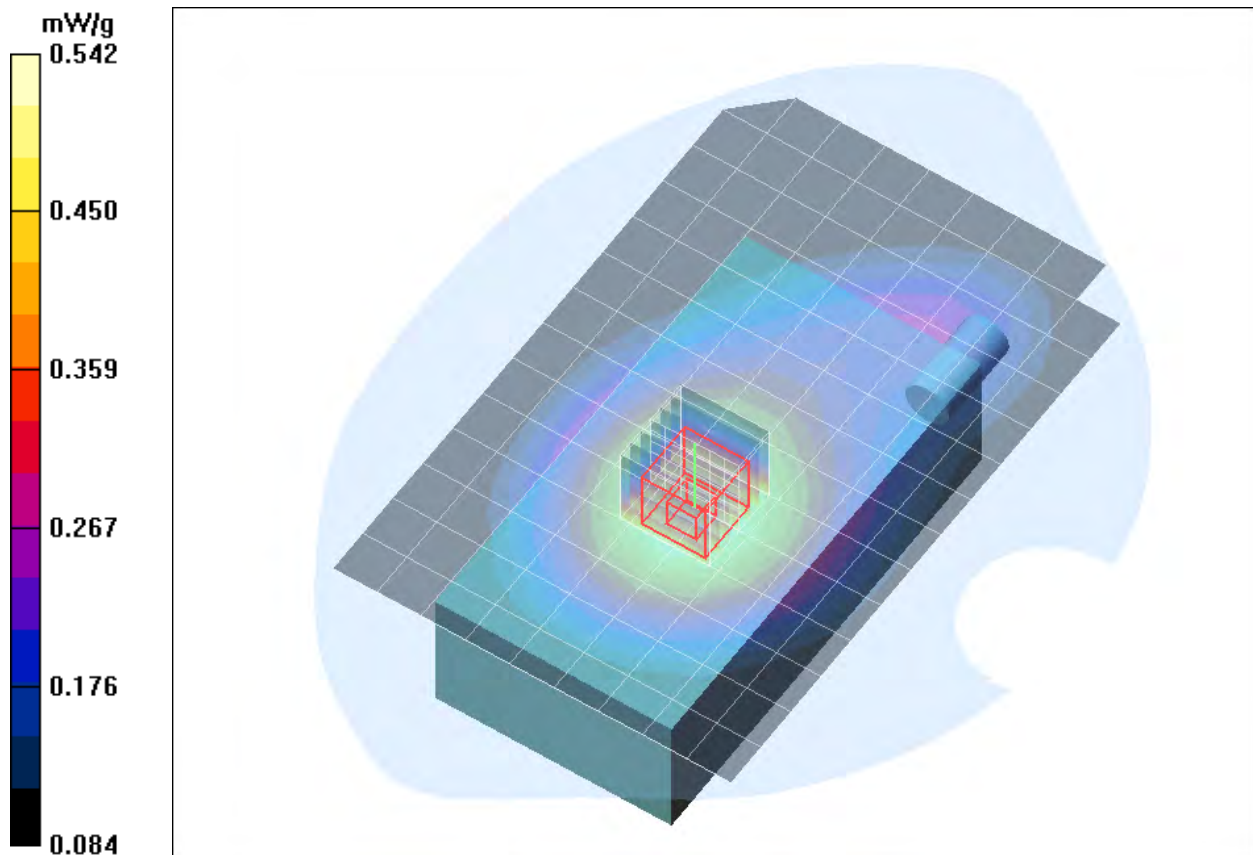

Fig. 9: SAR distribution for EDGE 850 (Class 10), channel 190, body worn configuration, display towards the phantom, 15 mm distance (July 26, 2010; Ambient Temperature: 21.3° C; Liquid Temperature: 20.7° C).

3 SAR Distribution Plots, PCS 1900 Head

Test Laboratory: Imst GmbH, DASY Yellow (II); File Name: [680_yplm_1.da4](#)

DUT: Datalogic ; Type: ELF; Serial: 354114011832680

Program Name: PCS 1900

Communication System: GSM 1900; Frequency: 1880 MHz; Duty Cycle: 1:8.3

Medium parameters used: $f = 1880$ MHz; $\sigma = 1.41$ mho/m; $\epsilon_r = 39.8$; $\rho = 1000$ kg/m³

Phantom section: Left Section

DASY4 Configuration:

- Probe: EX3DV4 - SN3536; ConvF(7.95, 7.95, 7.95); Calibrated: 18.09.2009
- Sensor-Surface: 4mm (Mechanical Surface Detection)
- Electronics: DAE3 Sn335; Calibrated: 10.02.2010
- Phantom: SAM Glycol 1340; Type: QD 000 P40 CB; Serial: TP-1340
- Measurement SW: DASY4, V4.7 Build 80; Postprocessing SW: SEMCAD, V1.8 Build 186

Cheek Left/Area Scan (9x14x1): Measurement grid: dx=15mm, dy=15mm

Maximum value of SAR (measured) = 0.473 mW/g

Cheek Left/Zoom Scan (7x7x7)/Cube 0: Measurement grid: dx=5mm, dy=5mm, dz=5mm

Reference Value = 11.2 V/m; Power Drift = 0.045 dB

Peak SAR (extrapolated) = 0.822 W/kg

SAR(1 g) = 0.453 mW/g; SAR(10 g) = 0.248 mW/g

Maximum value of SAR (measured) = 0.500 mW/g

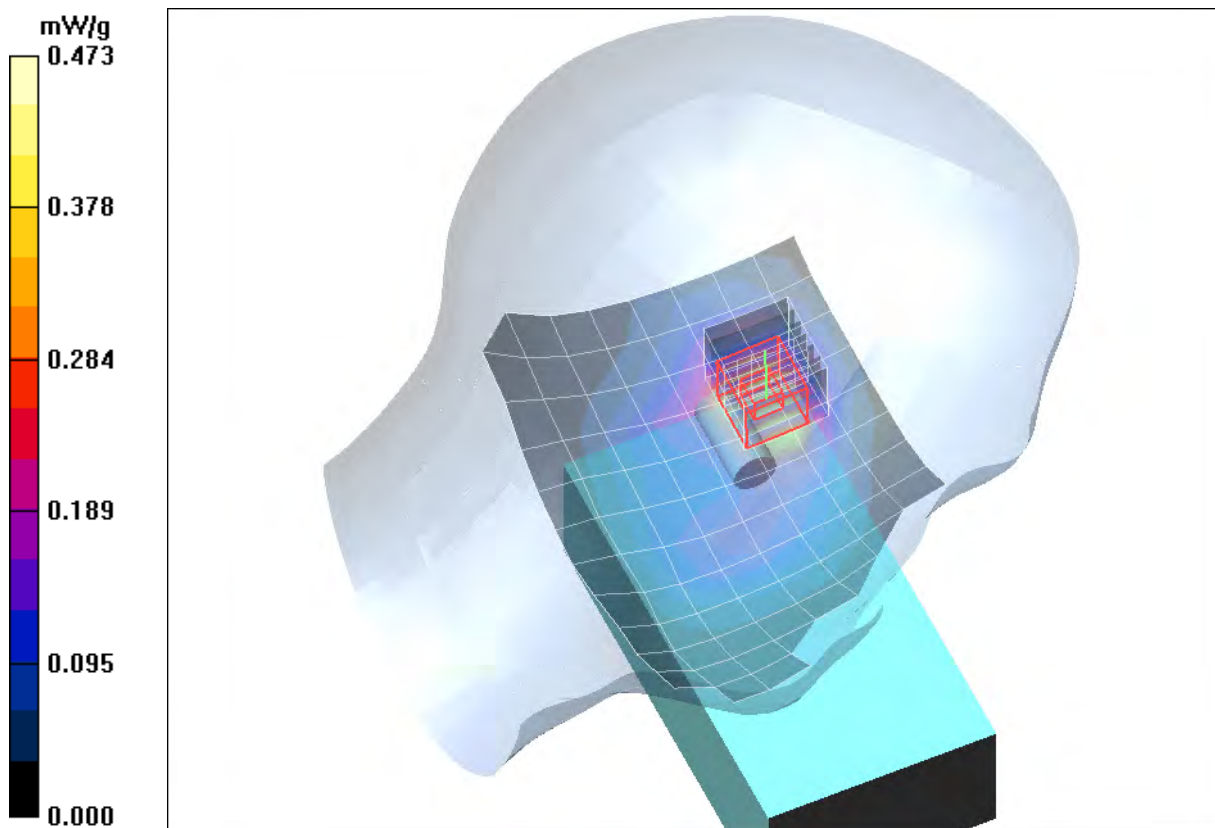

Fig. 10: SAR distribution for PCS 1900, channel 661, cheek position, left side of head (July 12, 2010; Ambient Temperature: 21.4° C; Liquid Temperature : 20.8° C).

Test Laboratory: Imst GmbH, DASY Yellow (II); File Name: [680_yplm_2.da4](#)

DUT: Datalogic ; Type: ELF; Serial: 354114011832680

Program Name: PCS 1900

Communication System: GSM 1900; Frequency: 1880 MHz;Duty Cycle: 1:8.3

Medium parameters used: $f = 1880$ MHz; $\sigma = 1.41$ mho/m; $\epsilon_r = 39.8$; $\rho = 1000$ kg/m³

Phantom section: Left Section

DASY4 Configuration:

- Probe: EX3DV4 - SN3536; ConvF(7.95, 7.95, 7.95); Calibrated: 18.09.2009
- Sensor-Surface: 4mm (Mechanical Surface Detection)
- Electronics: DAE3 Sn335; Calibrated: 10.02.2010
- Phantom: SAM Glycol 1340; Type: QD 000 P40 CB; Serial: TP-1340
- Measurement SW: DASY4, V4.7 Build 80; Postprocessing SW: SEMCAD, V1.8 Build 186

Tilted Left/Area Scan (9x14x1): Measurement grid: dx=15mm, dy=15mm

Maximum value of SAR (measured) = 0.463 mW/g

Tilted Left/Zoom Scan (7x7x7)/Cube 0: Measurement grid: dx=5mm, dy=5mm, dz=5mm

Reference Value = 13.1 V/m; Power Drift = 0.032 dB

Peak SAR (extrapolated) = 0.853 W/kg

SAR(1 g) = 0.456 mW/g; SAR(10 g) = 0.240 mW/g

Maximum value of SAR (measured) = 0.504 mW/g

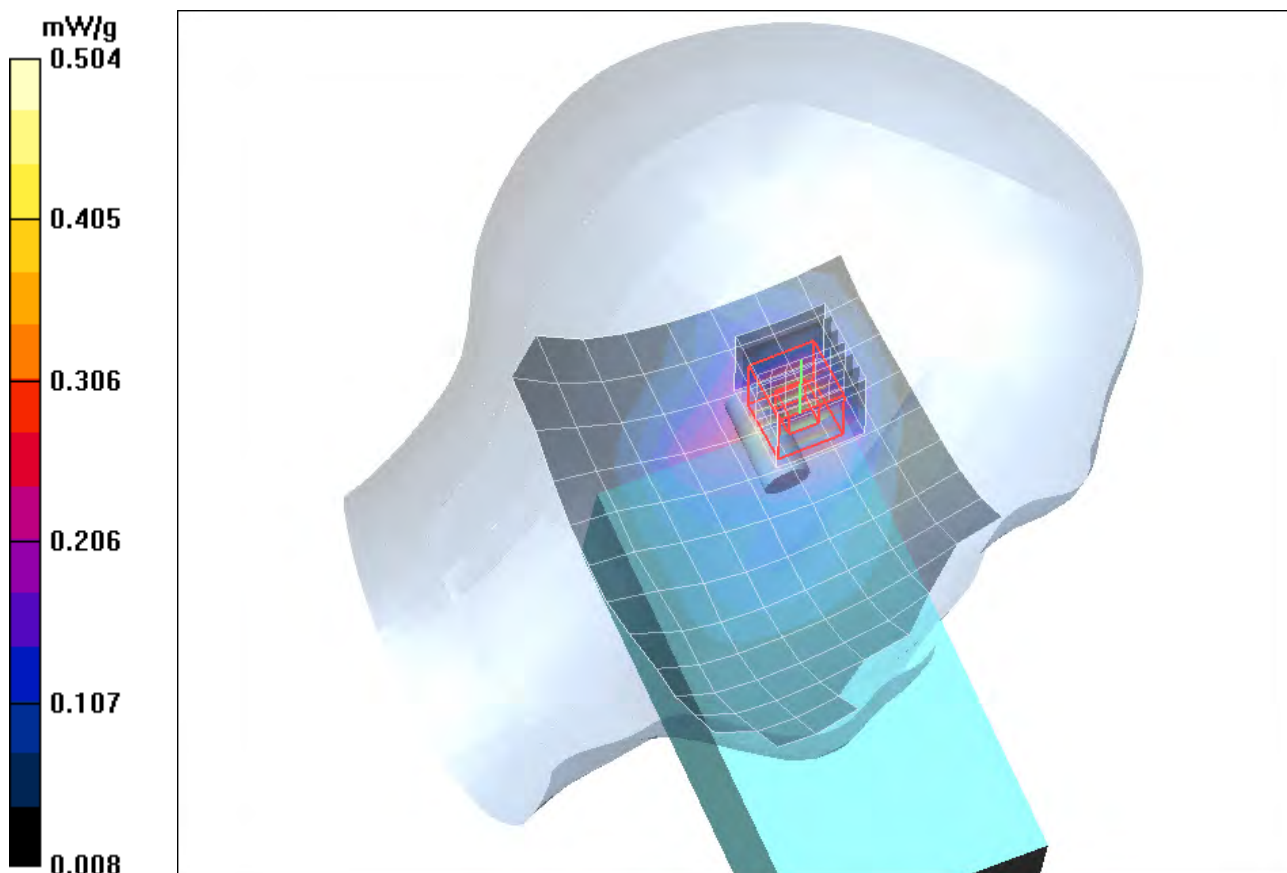

Fig. 11: SAR distribution for PCS 1900, channel 661, tilted position, left side of head (July 12, 2010; Ambient Temperature: 21.4° C; Liquid Temperature : 20.8° C).

Test Laboratory: Imst GmbH, DASY Yellow (II); File Name: [680_yprm_1.da4](#)

DUT: Datalogic ; Type: ELF; Serial: 354114011832680
Program Name: PCS 1900

Communication System: GSM 1900; Frequency: 1880 MHz; Duty Cycle: 1:8.3
Medium parameters used: $f = 1880$ MHz; $\sigma = 1.41$ mho/m; $\epsilon_r = 39.8$; $\rho = 1000$ kg/m³
Phantom section: Right Section

DASY4 Configuration:

- Probe: EX3DV4 - SN3536; ConvF(7.95, 7.95, 7.95); Calibrated: 18.09.2009
- Sensor-Surface: 4mm (Mechanical Surface Detection)
- Electronics: DAE3 Sn335; Calibrated: 10.02.2010
- Phantom: SAM Glycol 1340; Type: QD 000 P40 CB; Serial: TP-1340
- Measurement SW: DASY4, V4.7 Build 80; Postprocessing SW: SEMCAD, V1.8 Build 186

Cheek Right/Area Scan (9x14x1): Measurement grid: $dx=15$ mm, $dy=15$ mm

Maximum value of SAR (measured) = 0.240 mW/g

Cheek Right/Zoom Scan (7x7x7)/Cube 0: Measurement grid: $dx=5$ mm, $dy=5$ mm, $dz=5$ mm

Reference Value = 12.8 V/m; Power Drift = 0.004 dB

Peak SAR (extrapolated) = 0.406 W/kg

SAR(1 g) = 0.235 mW/g; SAR(10 g) = 0.140 mW/g

Maximum value of SAR (measured) = 0.255 mW/g

Cheek Right/Zoom Scan (7x7x7)/Cube 1: Measurement grid: $dx=5$ mm, $dy=5$ mm, $dz=5$ mm

Reference Value = 12.8 V/m; Power Drift = 0.004 dB

Peak SAR (extrapolated) = 0.367 W/kg

SAR(1 g) = 0.222 mW/g; SAR(10 g) = 0.140 mW/g

Maximum value of SAR (measured) = 0.239 mW/g

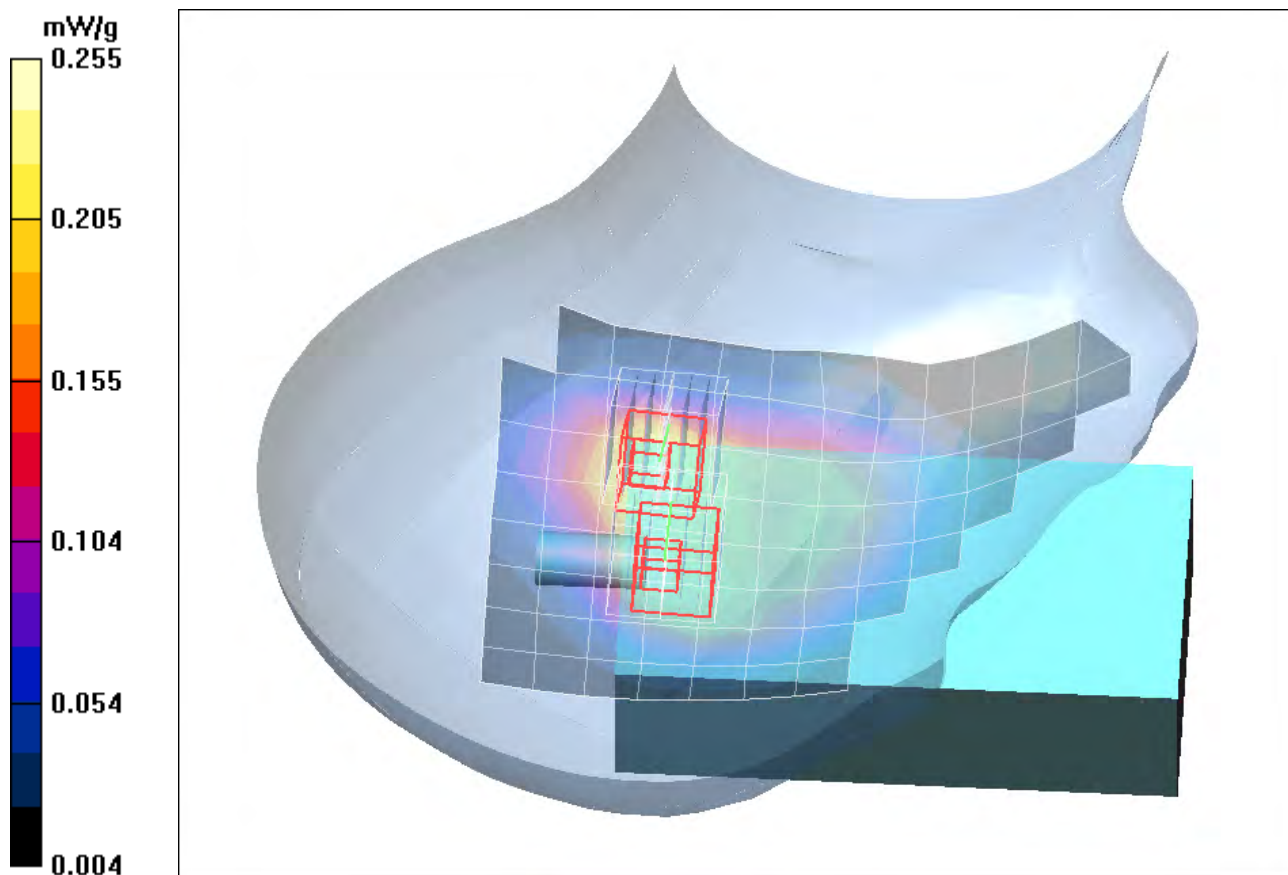

Fig. 12: SAR distribution for PCS 1900, channel 661, cheek position, right side of head (July 12, 2010; Ambient Temperature: 21.4° C; Liquid Temperature : 20.8° C).

Test Laboratory: Imst GmbH, DASY Yellow (II); File Name: [680_yprm_2.da4](#)

DUT: Datalogic ; Type: ELF; Serial: 354114011832680
Program Name: PCS 1900

Communication System: GSM 1900; Frequency: 1880 MHz; Duty Cycle: 1:8.3
Medium parameters used: $f = 1880$ MHz; $\sigma = 1.41$ mho/m; $\epsilon_r = 39.8$; $\rho = 1000$ kg/m³
Phantom section: Right Section

DASY4 Configuration:

- Probe: EX3DV4 - SN3536; ConvF(7.95, 7.95, 7.95); Calibrated: 18.09.2009
- Sensor-Surface: 4mm (Mechanical Surface Detection)
- Electronics: DAE3 Sn335; Calibrated: 10.02.2010
- Phantom: SAM Glycol 1340; Type: QD 000 P40 CB; Serial: TP-1340
- Measurement SW: DASY4, V4.7 Build 80; Postprocessing SW: SEMCAD, V1.8 Build 186

Tilted Right/Area Scan (9x14x1): Measurement grid: dx=15mm, dy=15mm

Maximum value of SAR (measured) = 0.280 mW/g

Tilted Right/Zoom Scan (7x7x7)/Cube 0: Measurement grid: dx=5mm, dy=5mm, dz=5mm

Reference Value = 14.1 V/m; Power Drift = 0.012 dB

Peak SAR (extrapolated) = 0.446 W/kg

SAR(1 g) = 0.267 mW/g; SAR(10 g) = 0.160 mW/g

Maximum value of SAR (measured) = 0.286 mW/g

Tilted Right/Zoom Scan (7x7x7)/Cube 1: Measurement grid: dx=5mm, dy=5mm, dz=5mm

Reference Value = 14.1 V/m; Power Drift = 0.012 dB

Peak SAR (extrapolated) = 0.438 W/kg

SAR(1 g) = 0.253 mW/g; SAR(10 g) = 0.150 mW/g

Maximum value of SAR (measured) = 0.275 mW/g

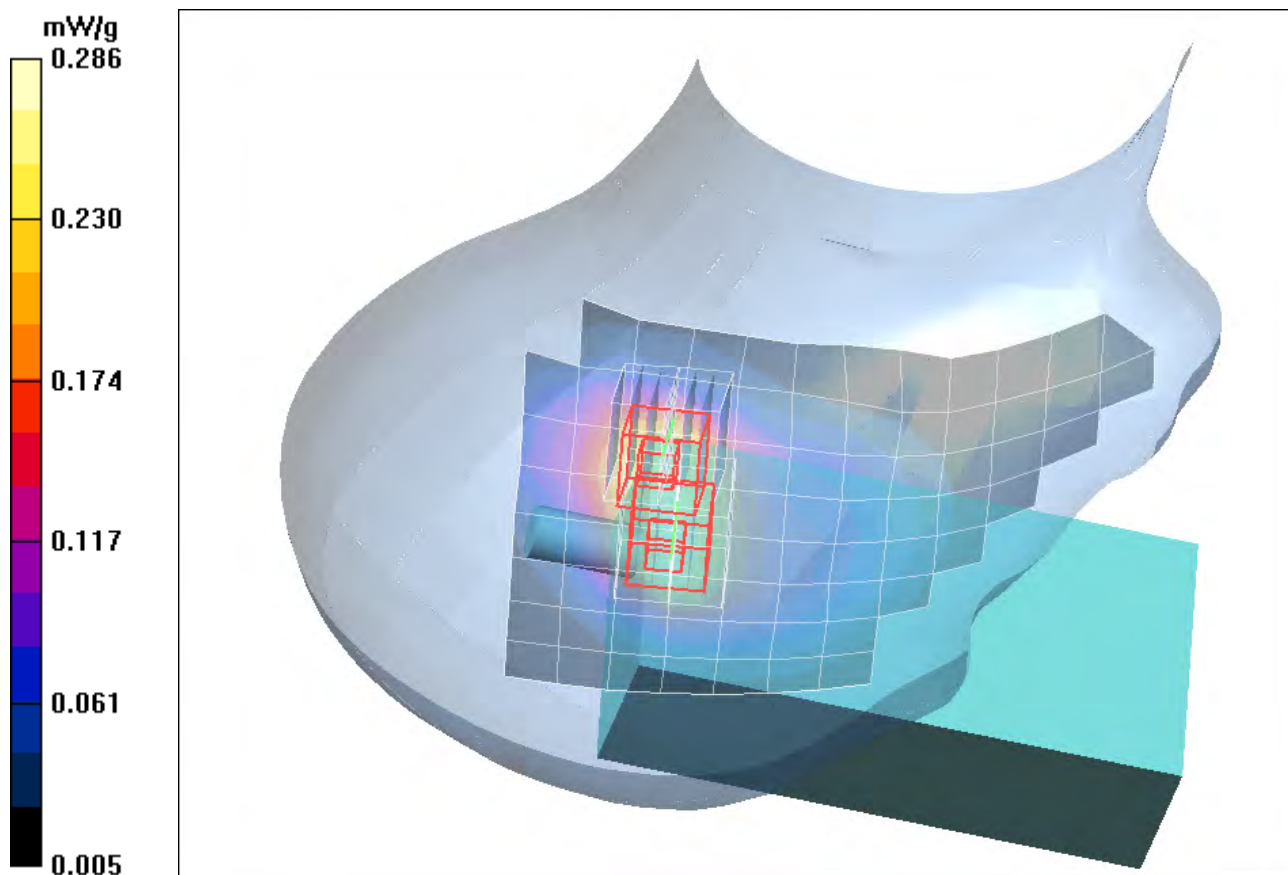

Fig. 13: SAR distribution for PCS 1900, channel 661, tilted position, right side of head (July 12, 2010; Ambient Temperature: 21.4° C; Liquid Temperature : 20.8° C)

4 SAR Distribution Plots, PCS / GPRS / EDGE 1900 Body

Test Laboratory: Imst GmbH, DASY Yellow (II); File Name: [680_yphm_1_dspl_up_gprs_15mm.da4](#)

DUT: Datalogic ; Type: ELF; Serial: 354114011832680

Program Name: GPRS 1900

Communication System: GPRS 1900; Frequency: 1880 MHz; Duty Cycle: 1:4

Medium parameters used: $f = 1880$ MHz; $\sigma = 1.52$ mho/m; $\epsilon_r = 53.1$; $\rho = 1000$ kg/m³

Phantom section: Flat Section

DASY4 Configuration:

- Probe: EX3DV4 - SN3536; ConvF(8.11, 8.11, 8.11); Calibrated: 18.09.2009

- Sensor-Surface: 4mm (Mechanical Surface Detection)

- Electronics: DAE3 Sn335; Calibrated: 10.02.2010

- Phantom: SAM Glycol 1340; Type: QD 000 P40 CB; Serial: TP-1340

- Measurement SW: DASY4, V4.7 Build 80; Postprocessing SW: SEMCAD, V1.8 Build 186

Body Worn/Area Scan (10x15x1): Measurement grid: dx=15mm, dy=15mm

Maximum value of SAR (measured) = 0.097 mW/g

Body Worn/Zoom Scan (7x7x7)/Cube 0: Measurement grid: dx=5mm, dy=5mm, dz=5mm

Reference Value = 8.04 V/m; Power Drift = -0.030 dB

Peak SAR (extrapolated) = 0.161 W/kg

SAR(1 g) = 0.098 mW/g; SAR(10 g) = 0.059 mW/g

Maximum value of SAR (measured) = 0.106 mW/g

Body Worn/Zoom Scan (7x7x7)/Cube 1: Measurement grid: dx=5mm, dy=5mm, dz=5mm

Reference Value = 8.04 V/m; Power Drift = -0.030 dB

Peak SAR (extrapolated) = 0.138 W/kg

SAR(1 g) = 0.091 mW/g; SAR(10 g) = 0.059 mW/g

Maximum value of SAR (measured) = 0.098 mW/g

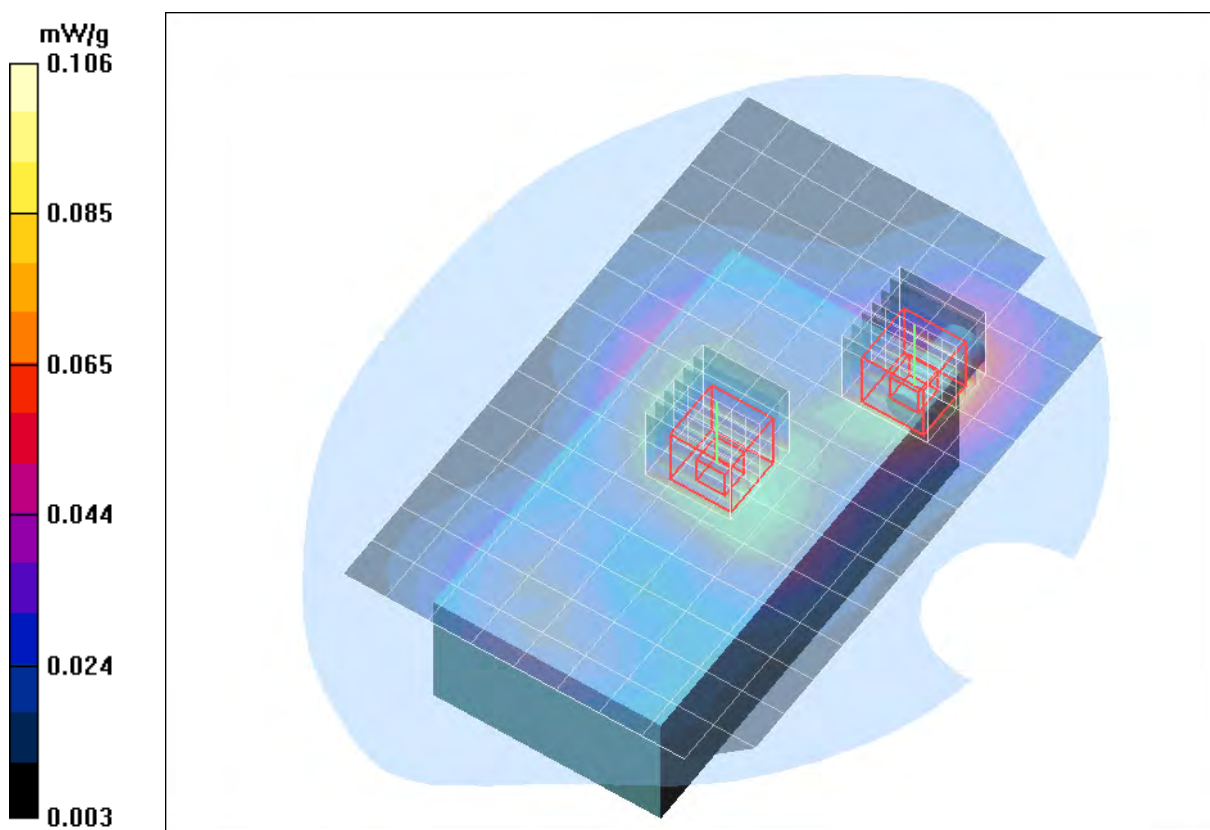

Fig. 14: SAR distribution for GPRS 1900 (Class 10), channel 661, body worn configuration, display towards the phantom, 15 mm distance (July 21, 2010; Ambient Temperature: 21.1° C; Liquid Temperature: 20.5° C).

Test Laboratory: Imst GmbH, DASY Yellow (II); File Name:
[680_yphm_1_dspl_down_gprs_15mm.da4](#)

DUT: Datalogic ; Type: ELF; Serial: 354114011832680
 Program Name: GPRS 1900

Communication System: GPRS 1900; Frequency: 1880 MHz; Duty Cycle: 1:4
 Medium parameters used: $f = 1880$ MHz; $\sigma = 1.52$ mho/m; $\epsilon_r = 53.1$; $\rho = 1000$ kg/m³
 Phantom section: Flat Section

DASY4 Configuration:

- Probe: EX3DV4 - SN3536; ConvF(8.11, 8.11, 8.11); Calibrated: 18.09.2009
- Sensor-Surface: 4mm (Mechanical Surface Detection)
- Electronics: DAE3 Sn335; Calibrated: 10.02.2010
- Phantom: SAM Glycol 1340; Type: QD 000 P40 CB; Serial: TP-1340
- Measurement SW: DASY4, V4.7 Build 80; Postprocessing SW: SEMCAD, V1.8 Build 186

Body Worn/Area Scan (10x15x1): Measurement grid: dx=15mm, dy=15mm

Maximum value of SAR (measured) = 0.159 mW/g

Body Worn/Zoom Scan (7x7x7)/Cube 0: Measurement grid: dx=5mm, dy=5mm, dz=5mm

Reference Value = 7.48 V/m; Power Drift = 0.014 dB

Peak SAR (extrapolated) = 0.251 W/kg

SAR(1 g) = 0.158 mW/g; SAR(10 g) = 0.098 mW/g

Maximum value of SAR (measured) = 0.169 mW/g

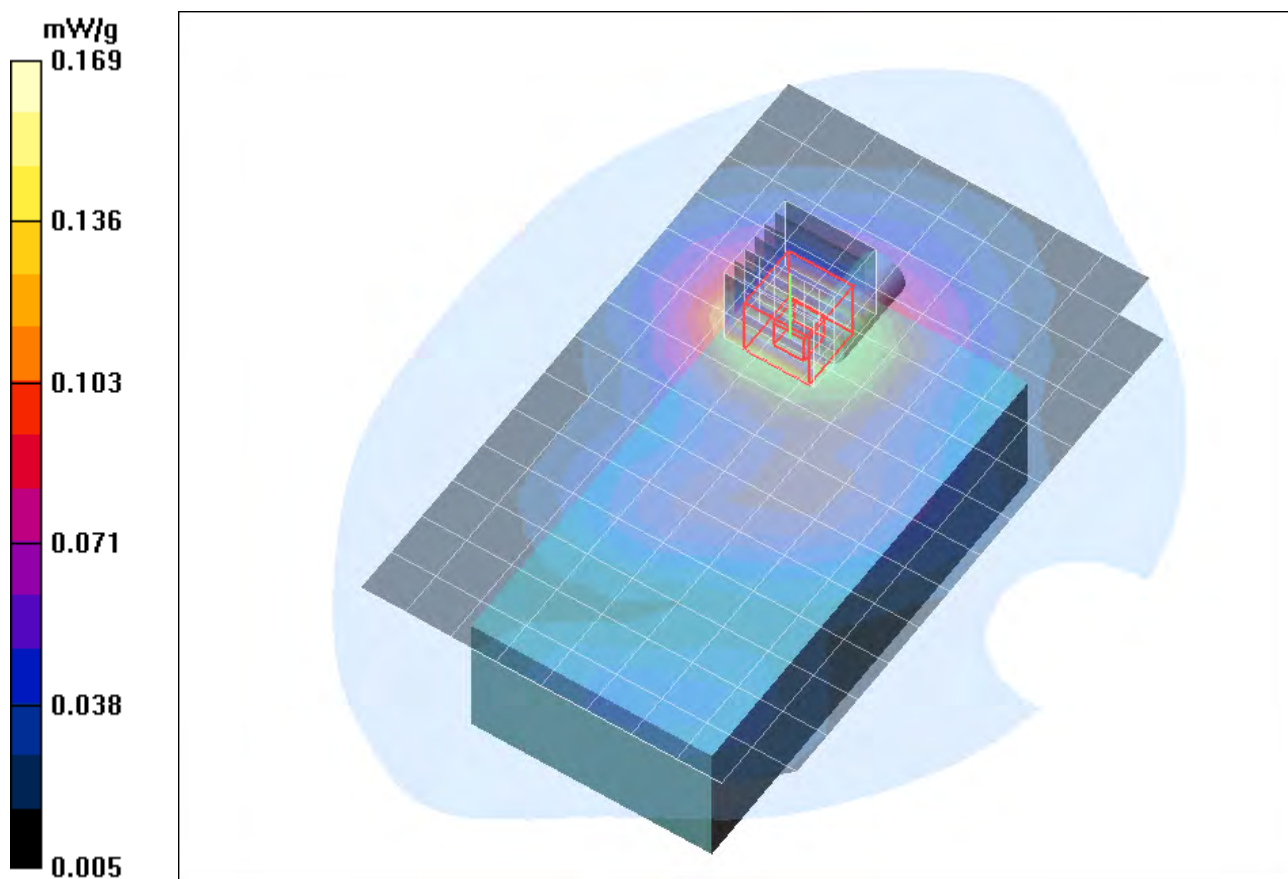

Fig. 15: SAR distribution for GPRS 1900 (Class 10), channel 661, body worn configuration, display towards the ground, 15 mm distance (July 21, 2010; Ambient Temperature: 21.1° C; Liquid Temperature: 20.5° C).

Test Laboratory: Imst GmbH, DASY Yellow (II); File Name: [680_yphm_2_dspl_up_HS_15mm.da4](#)

DUT: Datalogic ; Type: ELF; Serial: 354114011832680
Program Name: PCS 1900

Communication System: GSM 1900; Frequency: 1880 MHz; Duty Cycle: 1:8.3
Medium parameters used: $f = 1880$ MHz; $\sigma = 1.52$ mho/m; $\epsilon_r = 53.1$; $\rho = 1000$ kg/m³
Phantom section: Flat Section

DASY4 Configuration:

- Probe: EX3DV4 - SN3536; ConvF(8.11, 8.11, 8.11); Calibrated: 18.09.2009
- Sensor-Surface: 4mm (Mechanical Surface Detection)
- Electronics: DAE3 Sn335; Calibrated: 10.02.2010
- Phantom: SAM Glycol 1340; Type: QD 000 P40 CB; Serial: TP-1340
- Measurement SW: DASY4, V4.7 Build 80; Postprocessing SW: SEMCAD, V1.8 Build 186

Body Worn/Area Scan (10x15x1): Measurement grid: $dx=15$ mm, $dy=15$ mm

Maximum value of SAR (measured) = 0.076 mW/g

Body Worn/Zoom Scan (7x7x7)/Cube 0: Measurement grid: $dx=5$ mm, $dy=5$ mm, $dz=5$ mm

Reference Value = 7.08 V/m; Power Drift = 0.027 dB

Peak SAR (extrapolated) = 0.110 W/kg

SAR(1 g) = 0.071 mW/g; SAR(10 g) = 0.047 mW/g

Body Worn/Zoom Scan (7x7x7)/Cube 1: Measurement grid: $dx=5$ mm, $dy=5$ mm, $dz=5$ mm

Reference Value = 7.08 V/m; Power Drift = 0.027 dB

Peak SAR (extrapolated) = 0.114 W/kg

SAR(1 g) = 0.069 mW/g; SAR(10 g) = 0.042 mW/g

Maximum value of SAR (measured) = 0.075 mW/g

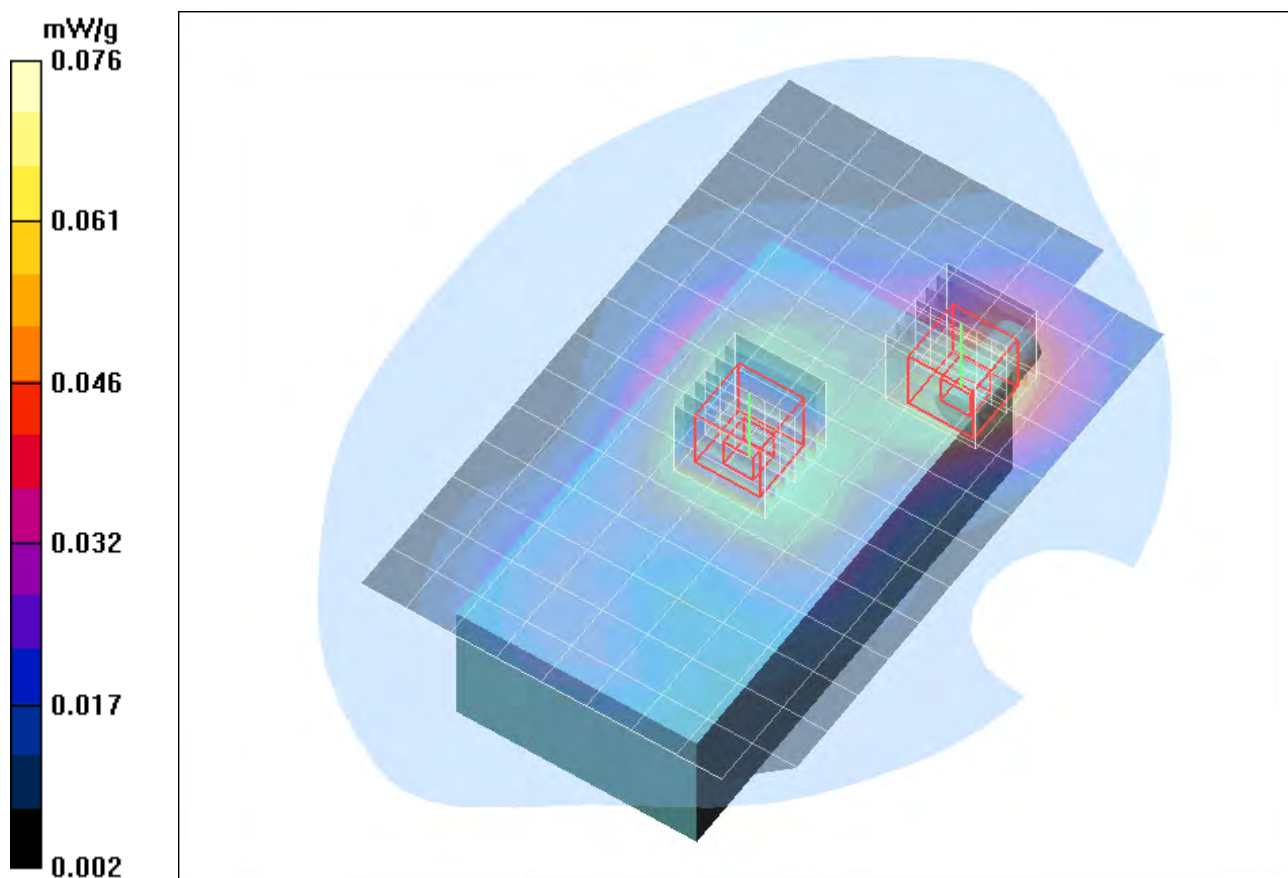

Fig. 16: SAR distribution for PCS 1900, channel 661, body worn configuration, display towards the phantom, headset attached, 15 mm distance (July 21, 2010; Ambient Temperature: 21.1° C; Liquid Temperature: 20.5° C).

Test Laboratory: Imst GmbH, DASY Yellow (II); **File Name:**
[680_yphm_2_dspl_down_HS_15mm.da4](#)

DUT: Datalogic ; **Type:** ELF; **Serial:** 354114011832680
Program Name: PCS 1900

Communication System: GSM 1900; Frequency: 1880 MHz; Duty Cycle: 1:8.3
 Medium parameters used: $f = 1880$ MHz; $\sigma = 1.52$ mho/m; $\epsilon_r = 53.1$; $\rho = 1000$ kg/m³
 Phantom section: Flat Section

DASY4 Configuration:

- Probe: EX3DV4 - SN3536; ConvF(8.11, 8.11, 8.11); Calibrated: 18.09.2009
- Sensor-Surface: 4mm (Mechanical Surface Detection)
- Electronics: DAE3 Sn335; Calibrated: 10.02.2010
- Phantom: SAM Glycol 1340; Type: QD 000 P40 CB; Serial: TP-1340
- Measurement SW: DASY4, V4.7 Build 80; Postprocessing SW: SEMCAD, V1.8 Build 186

Body Worn/Area Scan (10x15x1): Measurement grid: $dx=15$ mm, $dy=15$ mm

Maximum value of SAR (measured) = 0.094 mW/g

Body Worn/Zoom Scan (7x7x7)/Cube 0: Measurement grid: $dx=5$ mm, $dy=5$ mm, $dz=5$ mm

Reference Value = 5.24 V/m; Power Drift = 0.028 dB

Peak SAR (extrapolated) = 0.139 W/kg

SAR(1 g) = 0.088 mW/g; SAR(10 g) = 0.054 mW/g

Maximum value of SAR (measured) = 0.095 mW/g

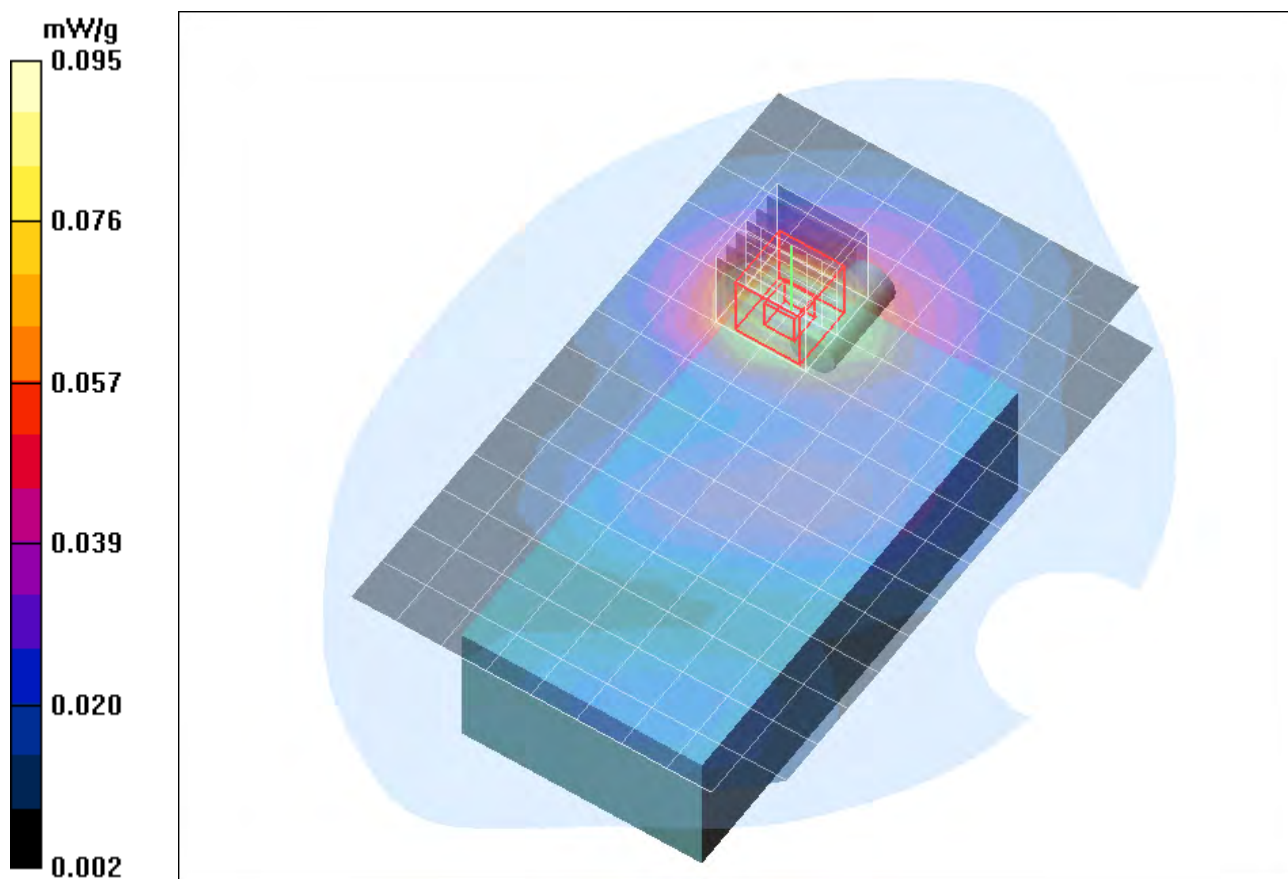

Fig. 17: SAR distribution for PCS 1900, channel 661, body worn configuration, display towards the ground, headset attached, 15 mm distance (July 21, 2010; Ambient Temperature: 21.1° C; Liquid Temperature: 20.5° C).

Test Laboratory: Imst GmbH, DASY Yellow (II); **File Name:**
[680_yphm_1_dspl_down_edge_15mm.da4](#)

DUT: Datalogic ; **Type:** ELF; **Serial:** 354114011832680
Program Name: EDGE 1900

Communication System: EDGE 1900; Frequency: 1880 MHz; Duty Cycle: 1:4
 Medium parameters used: $f = 1880$ MHz; $\sigma = 1.52$ mho/m; $\epsilon_r = 53.1$; $\rho = 1000$ kg/m³
 Phantom section: Flat Section

DASY4 Configuration:

- Probe: EX3DV4 - SN3536; ConvF(8.11, 8.11, 8.11); Calibrated: 18.09.2009
- Sensor-Surface: 4mm (Mechanical Surface Detection)
- Electronics: DAE3 Sn335; Calibrated: 10.02.2010
- Phantom: SAM Glycol 1340; Type: QD 000 P40 CB; Serial: TP-1340
- Measurement SW: DASY4, V4.7 Build 80; Postprocessing SW: SEMCAD, V1.8 Build 186

Body Worn/Area Scan (10x15x1): Measurement grid: $dx=15$ mm, $dy=15$ mm

Maximum value of SAR (measured) = 0.158 mW/g

Body Worn/Zoom Scan (7x7x7)/Cube 0: Measurement grid: $dx=5$ mm, $dy=5$ mm, $dz=5$ mm

Reference Value = 7.90 V/m; Power Drift = -0.137 dB

Peak SAR (extrapolated) = 0.236 W/kg

SAR(1 g) = 0.150 mW/g; SAR(10 g) = 0.094 mW/g

Maximum value of SAR (measured) = 0.161 mW/g

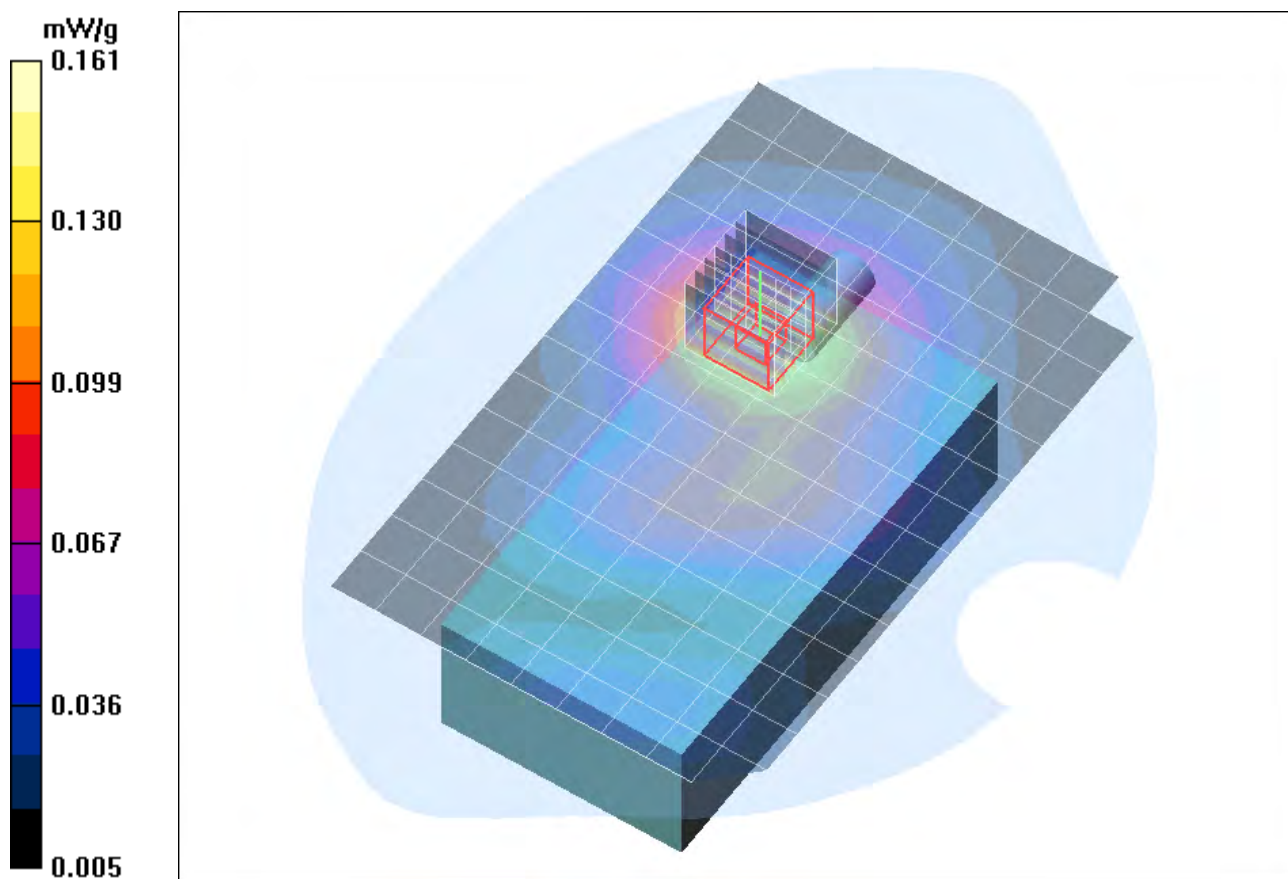

Fig. 18: SAR distribution for EDGE 1900 (Class 10), channel 661, body worn configuration, display towards the ground, 15 mm distance (July 21, 2010; Ambient Temperature: 21.1° C; Liquid Temperature: 20.5° C).

5 SAR Distribution Plots, WCDMA V (FDD) Head

Test Laboratory: IMST GmbH, DASY Blue (I); File Name: [680 buVIm 1.da4](#)

DUT: Datalogic ; Type: ELF; Serial: 354114011832680

Program Name: WCDMA V

Communication System: WCDMA (FDD) Band V; Frequency: 836.5 MHz; Duty Cycle: 1:1

Medium parameters used: $f = 836.5$ MHz; $\sigma = 0.92$ mho/m; $\epsilon_r = 39.6$; $\rho = 1000$ kg/m³

Phantom section: Left Section

DASY4 Configuration:

- Probe: ET3DV6R - SN1579; ConvF(6.34, 6.34, 6.34); Calibrated: 20.01.2010
- Sensor-Surface: 4mm (Mechanical Surface Detection)
- Electronics: DAE4 Sn631; Calibrated: 14.09.2009
- Phantom: SAM Sugar 1059; Type: Speag; Serial: 1059
- Measurement SW: DASY4, V4.7 Build 80; Postprocessing SW: SEMCAD, V1.8 Build 186

Cheek Left/Area Scan (9x14x1): Measurement grid: dx=15mm, dy=15mm

Maximum value of SAR (measured) = 0.603 mW/g

Cheek Left/Zoom Scan (7x7x7)/Cube 0: Measurement grid: dx=5mm, dy=5mm, dz=5mm

Reference Value = 22.2 V/m; Power Drift = 0.064 dB

Peak SAR (extrapolated) = 0.909 W/kg

SAR(1 g) = 0.607 mW/g; SAR(10 g) = 0.398 mW/g

Maximum value of SAR (measured) = 0.654 mW/g

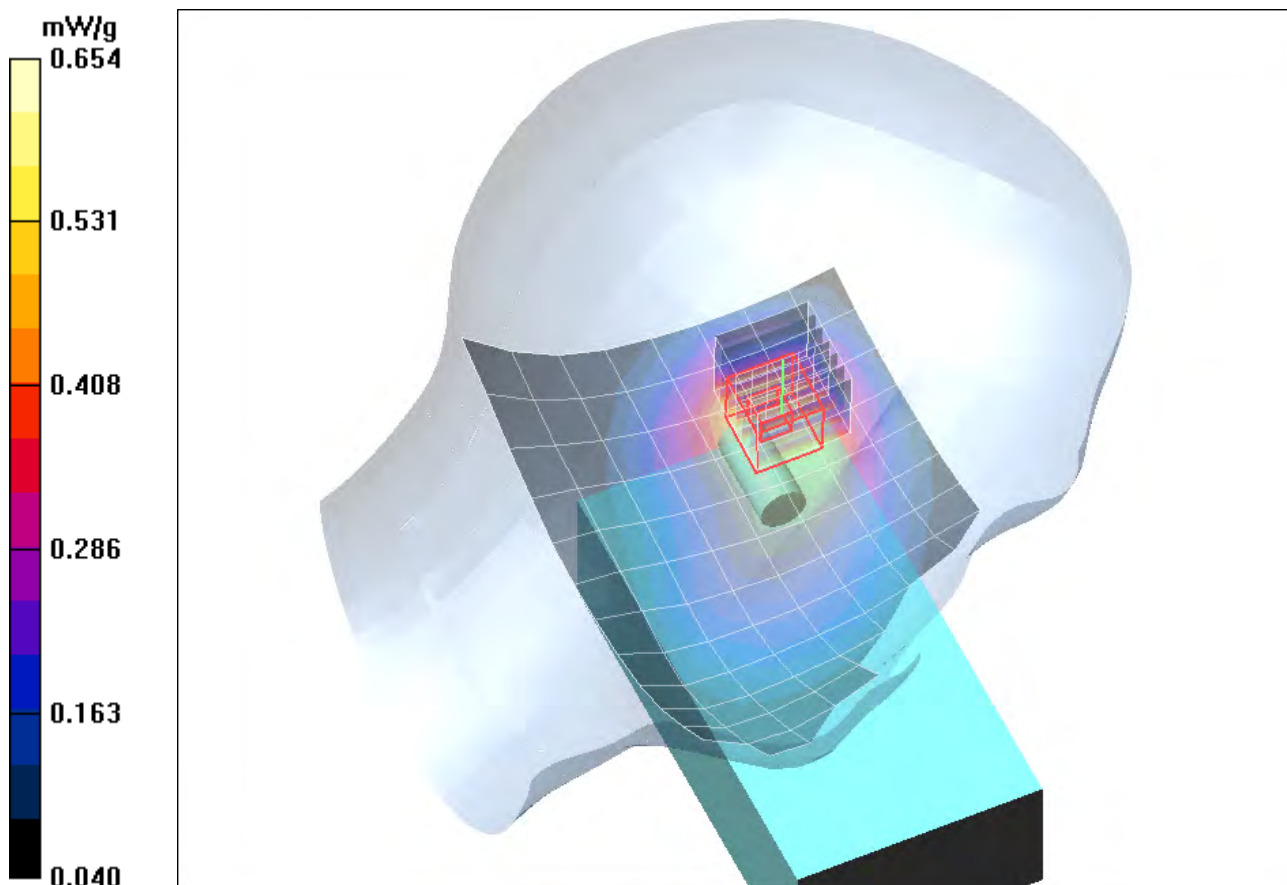

Fig. 19: SAR distribution for WCDMA V, channel 4183, cheek position, left side of head (July 20, 2010; Ambient Temperature: 21.3° C; Liquid Temperature: 20.7° C).

Test Laboratory: IMST GmbH, DASY Blue (I); File Name: [680 buVIm 2.da4](#)

DUT: Datalogic ; Type: ELF; Serial: 354114011832680

Program Name: WCDMA V

Communication System: WCDMA (FDD) Band V; Frequency: 836.5 MHz; Duty Cycle: 1:1

Medium parameters used: $f = 836.5$ MHz; $\sigma = 0.92$ mho/m; $\epsilon_r = 39.6$; $\rho = 1000$ kg/m³

Phantom section: Left Section

DASY4 Configuration:

- Probe: ET3DV6R - SN1579; ConvF(6.34, 6.34, 6.34); Calibrated: 20.01.2010
- Sensor-Surface: 4mm (Mechanical Surface Detection)
- Electronics: DAE4 Sn631; Calibrated: 14.09.2009
- Phantom: SAM Sugar 1059; Type: Speag; Serial: 1059
- Measurement SW: DASY4, V4.7 Build 80; Postprocessing SW: SEMCAD, V1.8 Build 186

Tilted Left/Area Scan (9x14x1): Measurement grid: dx=15mm, dy=15mm

Maximum value of SAR (measured) = 0.718 mW/g

Tilted Left/Zoom Scan (7x7x7)/Cube 0: Measurement grid: dx=5mm, dy=5mm, dz=5mm

Reference Value = 23.7 V/m; Power Drift = -0.087 dB

Peak SAR (extrapolated) = 1.08 W/kg

SAR(1 g) = 0.722 mW/g; SAR(10 g) = 0.457 mW/g

Maximum value of SAR (measured) = 0.781 mW/g

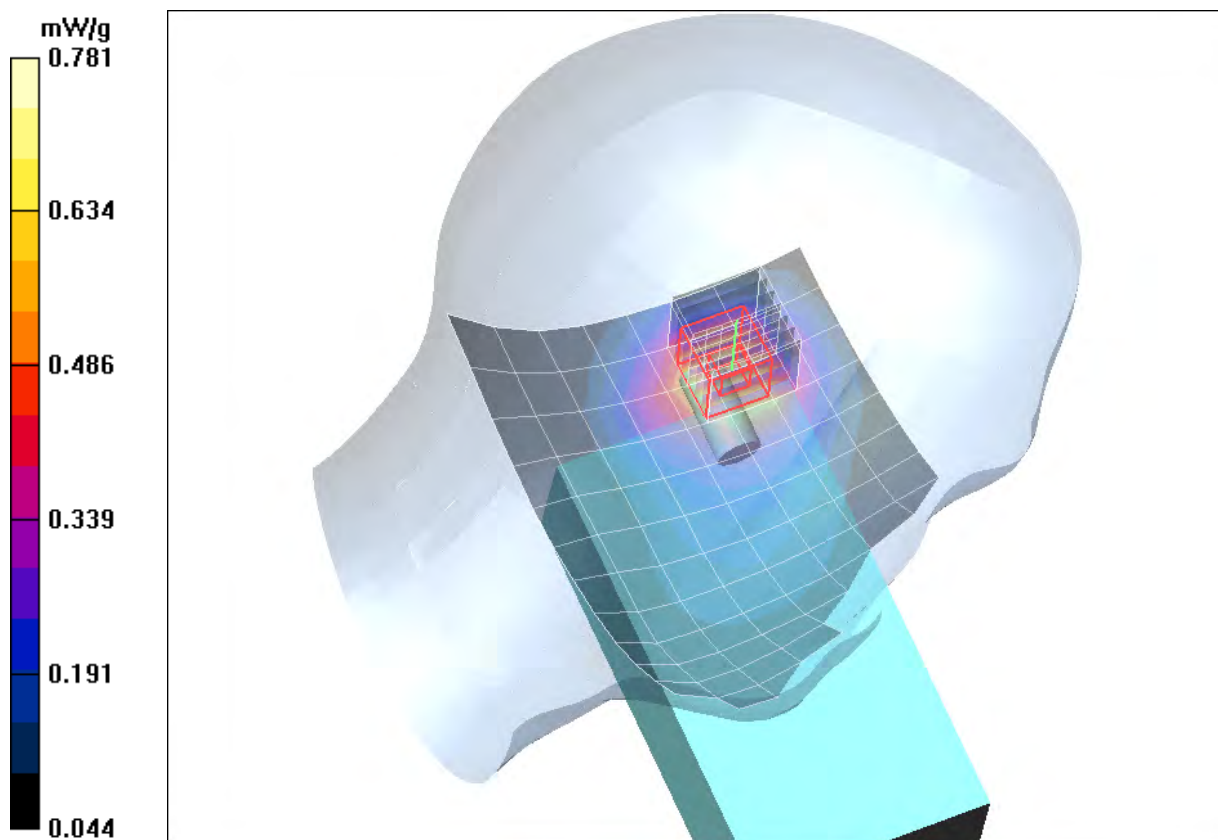

Fig. 20: SAR distribution for WCDMA V, channel 4183, tilted position, left side of head (July 20, 2010; Ambient Temperature: 21.3° C; Liquid Temperature: 20.7° C).

Test Laboratory: IMST GmbH, DASY Blue (I); File Name: [680 buVrm 1.da4](#)

DUT: Datalogic ; Type: ELF; Serial: 354114011832680

Program Name: WCDMA V

Communication System: WCDMA (FDD) Band V; Frequency: 836.5 MHz; Duty Cycle: 1:1

Medium parameters used: $f = 836.5$ MHz; $\sigma = 0.92$ mho/m; $\epsilon_r = 39.6$; $\rho = 1000$ kg/m³

Phantom section: Right Section

DASY4 Configuration:

- Probe: ET3DV6R - SN1579; ConvF(6.34, 6.34, 6.34); Calibrated: 20.01.2010
- Sensor-Surface: 4mm (Mechanical Surface Detection)
- Electronics: DAE4 Sn631; Calibrated: 14.09.2009
- Phantom: SAM Sugar 1059; Type: Speag; Serial: 1059
- Measurement SW: DASY4, V4.7 Build 80; Postprocessing SW: SEMCAD, V1.8 Build 186

Cheek Right/Area Scan (9x14x1): Measurement grid: dx=15mm, dy=15mm

Maximum value of SAR (measured) = 0.474 mW/g

Cheek Right/Zoom Scan (7x7x7)/Cube 0: Measurement grid: dx=5mm, dy=5mm, dz=5mm

Reference Value = 23.5 V/m; Power Drift = -0.128 dB

Peak SAR (extrapolated) = 0.609 W/kg

SAR(1 g) = 0.449 mW/g; SAR(10 g) = 0.321 mW/g

Maximum value of SAR (measured) = 0.479 mW/g

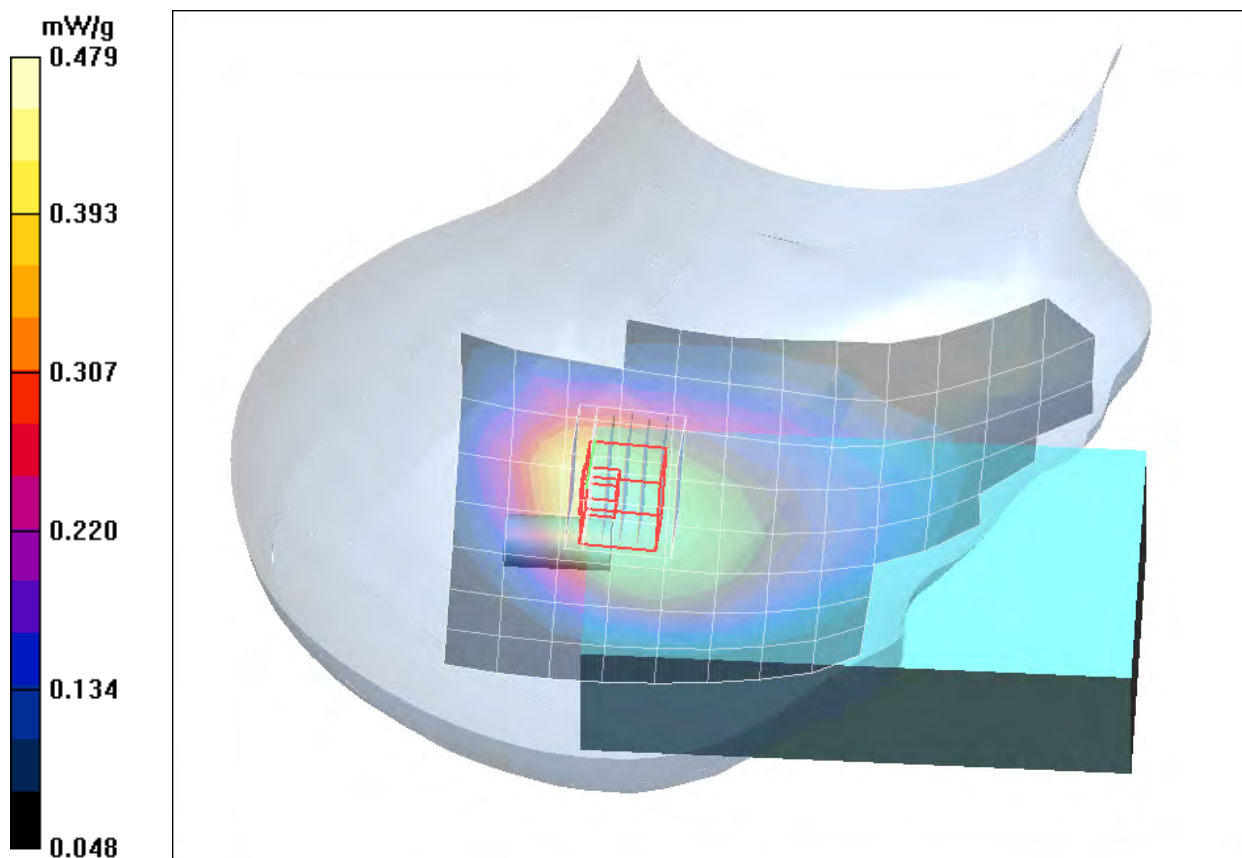

Fig. 21: SAR distribution for WCDMA V, channel 4183, cheek position, right side of head (July 20, 2010; Ambient Temperature: 21.3° C; Liquid Temperature: 20.7° C).

Test Laboratory: IMST GmbH, DASY Blue (I); File Name: [680 buVrm 2.da4](#)

DUT: Datalogic ; Type: ELF; Serial: 354114011832680

Program Name: WCDMA V

Communication System: WCDMA (FDD) Band V; Frequency: 836.5 MHz; Duty Cycle: 1:1

Medium parameters used: $f = 836.5$ MHz; $\sigma = 0.92$ mho/m; $\epsilon_r = 39.6$; $\rho = 1000$ kg/m³

Phantom section: Right Section

DASY4 Configuration:

- Probe: ET3DV6R - SN1579; ConvF(6.34, 6.34, 6.34); Calibrated: 20.01.2010
- Sensor-Surface: 4mm (Mechanical Surface Detection)
- Electronics: DAE4 Sn631; Calibrated: 14.09.2009
- Phantom: SAM Sugar 1059; Type: Speag; Serial: 1059
- Measurement SW: DASY4, V4.7 Build 80; Postprocessing SW: SEMCAD, V1.8 Build 186

Tilted Right/Area Scan (9x14x1): Measurement grid: dx=15mm, dy=15mm

Maximum value of SAR (measured) = 0.526 mW/g

Tilted Right/Zoom Scan (7x7x7)/Cube 0: Measurement grid: dx=5mm, dy=5mm, dz=5mm

Reference Value = 23.8 V/m; Power Drift = -0.122 dB

Peak SAR (extrapolated) = 0.733 W/kg

SAR(1 g) = 0.522 mW/g; SAR(10 g) = 0.351 mW/g

Maximum value of SAR (measured) = 0.556 mW/g

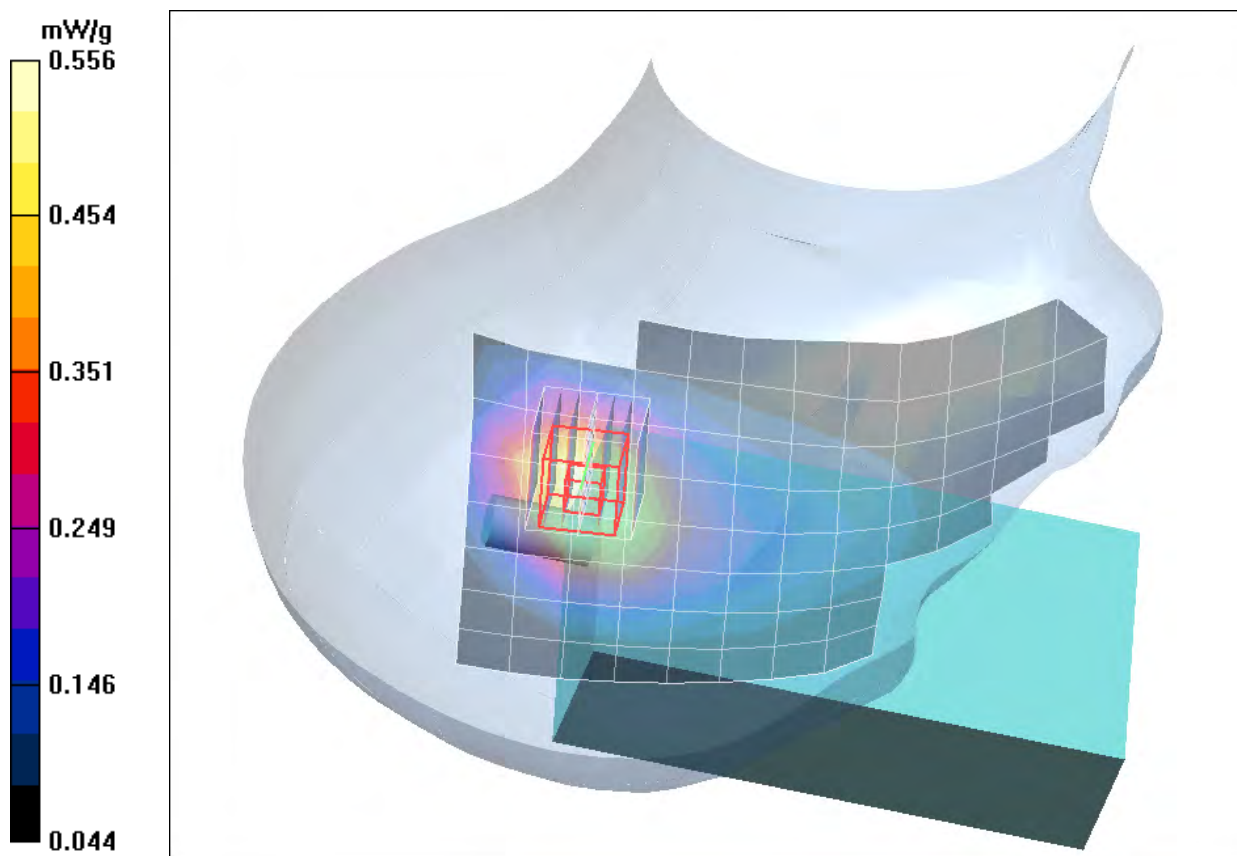

Fig. 22: SAR distribution for WCDMA V, channel 4183, tilted position, right side of head (July 20, 2010; Ambient Temperature: 21.3° C; Liquid Temperature: 20.7° C).

6 SAR Distribution Plots, WCDMA V (FDD) Body

Test Laboratory: IMST GmbH, DASY Blue (I); File Name: [680 buVhm 1 dspl up 15mm.da4](#)

DUT: Datalogic ; Type: ELF; Serial: 354114011832680

Program Name: WCDMA V

Communication System: WCDMA (FDD) Band V; Frequency: 836.5 MHz; Duty Cycle: 1:1

Medium parameters used: $f = 836.6$ MHz; $\sigma = 0.99$ mho/m; $\epsilon_r = 53.3$; $\rho = 1000$ kg/m³

Phantom section: Flat Section

DASY4 Configuration:

- Probe: ET3DV6R - SN1579; ConvF(6.21, 6.21, 6.21); Calibrated: 20.01.2010

- Sensor-Surface: 4mm (Mechanical Surface Detection)

- Electronics: DAE4 Sn631; Calibrated: 14.09.2009

- Phantom: SAM Sugar 1059; Type: Speag; Serial: 1059

- Measurement SW: DASY4, V4.7 Build 80; Postprocessing SW: SEMCAD, V1.8 Build 186

Body Worn/Area Scan (10x15x1): Measurement grid: dx=15mm, dy=15mm

Maximum value of SAR (measured) = 0.349 mW/g

Body Worn/Zoom Scan (7x7x7)/Cube 0: Measurement grid: dx=5mm, dy=5mm, dz=5mm

Reference Value = 16.8 V/m; Power Drift = 0.142 dB

Peak SAR (extrapolated) = 0.427 W/kg

SAR(1 g) = 0.339 mW/g; SAR(10 g) = 0.253 mW/g

Maximum value of SAR (measured) = 0.361 mW/g

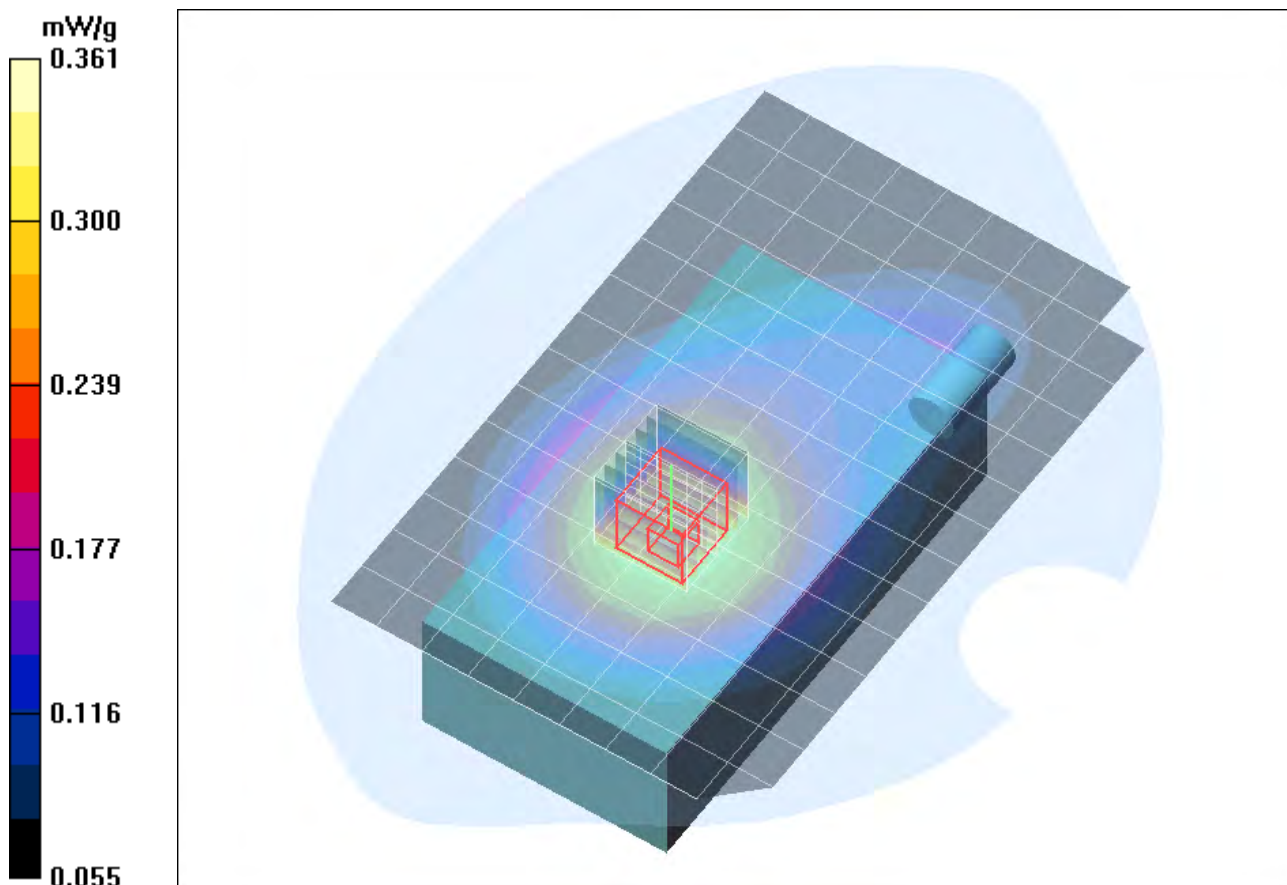

Fig. 23: SAR distribution for WCDMA V, channel 4183, body worn configuration, display towards the phantom, 15 mm distance (July 26, 2010; Ambient Temperature: 21.2° C; Liquid Temperature: 20.7° C).

Test Laboratory: IMST GmbH, DASY Blue (I); File Name: [680_buVhm_2_dspl_down_15mm.da4](#)

DUT: Datalogic ; Type: ELF; Serial: 354114011832680
Program Name: WCDMA V

Communication System: WCDMA (FDD) Band V; Frequency: 836.5 MHz; Duty Cycle: 1:1
Medium parameters used: $f = 836.6$ MHz; $\sigma = 0.99$ mho/m; $\epsilon_r = 53.3$; $\rho = 1000$ kg/m³
Phantom section: Flat Section

DASY4 Configuration:

- Probe: ET3DV6R - SN1579; ConvF(6.21, 6.21, 6.21); Calibrated: 20.01.2010
- Sensor-Surface: 4mm (Mechanical Surface Detection)
- Electronics: DAE4 Sn631; Calibrated: 14.09.2009
- Phantom: SAM Sugar 1059; Type: Speag; Serial: 1059
- Measurement SW: DASY4, V4.7 Build 80; Postprocessing SW: SEMCAD, V1.8 Build 186

Body Worn/Area Scan (10x15x1): Measurement grid: dx=15mm, dy=15mm

Maximum value of SAR (measured) = 0.263 mW/g

Body Worn/Zoom Scan (7x7x7)/Cube 0: Measurement grid: dx=5mm, dy=5mm, dz=5mm

Reference Value = 14.9 V/m; Power Drift = -0.035 dB

Peak SAR (extrapolated) = 0.329 W/kg

SAR(1 g) = 0.256 mW/g; SAR(10 g) = 0.189 mW/g

Maximum value of SAR (measured) = 0.273 mW/g

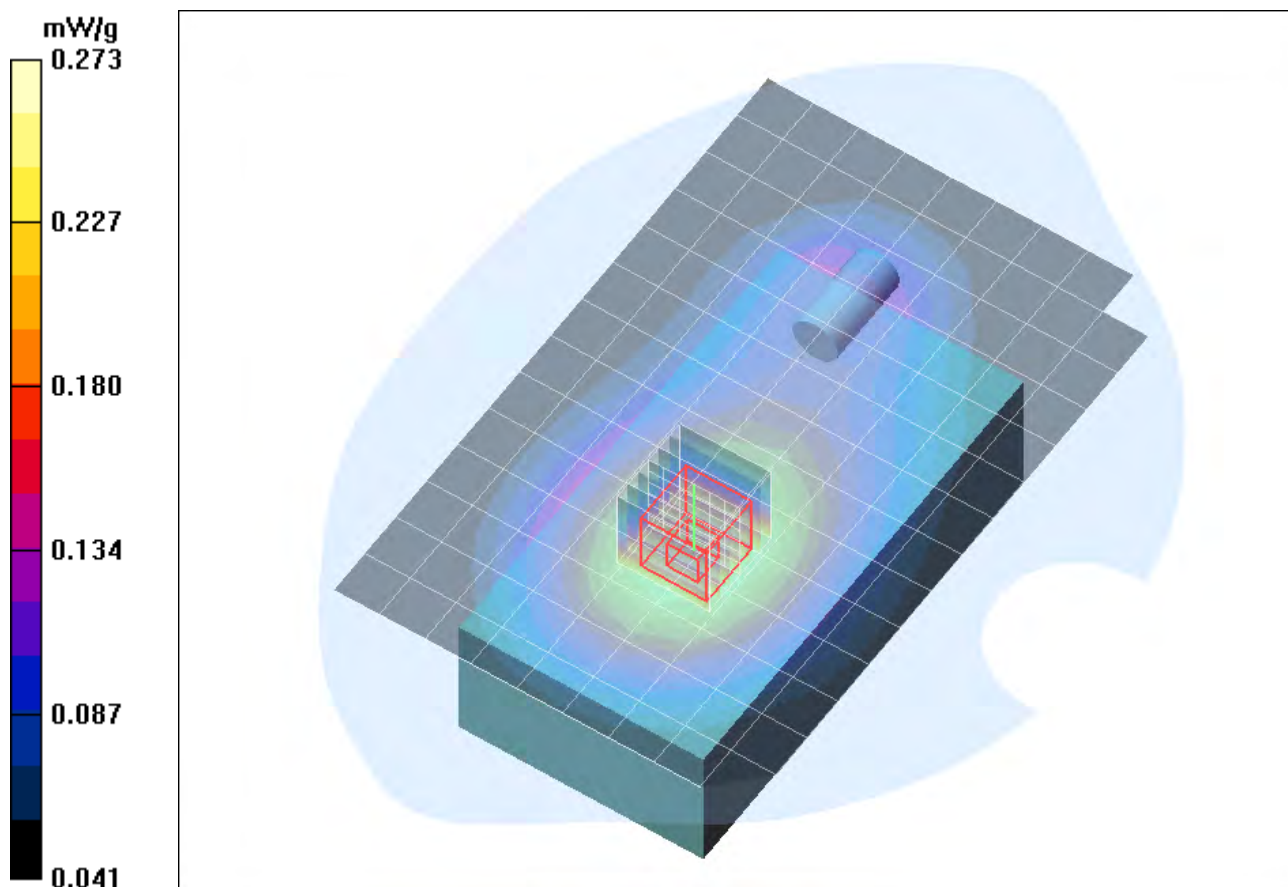

Fig. 24: SAR distribution for WCDMA V, channel 4183, body worn configuration, display towards the ground, 15 mm distance (July 26, 2010; Ambient Temperature: 21.2° C; Liquid Temperature: 20.7° C).

Test Laboratory: IMST GmbH, DASY Blue (I); File Name: [680_buVhm_3_dspl_up_HS_15mm.da4](#)

DUT: Datalogic ; Type: ELF; Serial: 354114011832680
Program Name: WCDMA V

Communication System: WCDMA (FDD) Band V; Frequency: 836.5 MHz; Duty Cycle: 1:1
Medium parameters used: $f = 836.6$ MHz; $\sigma = 0.99$ mho/m; $\epsilon_r = 53.3$; $\rho = 1000$ kg/m³
Phantom section: Flat Section

DASY4 Configuration:

- Probe: ET3DV6R - SN1579; ConvF(6.21, 6.21, 6.21); Calibrated: 20.01.2010
- Sensor-Surface: 4mm (Mechanical Surface Detection)
- Electronics: DAE4 Sn631; Calibrated: 14.09.2009
- Phantom: SAM Sugar 1059; Type: Speag; Serial: 1059
- Measurement SW: DASY4, V4.7 Build 80; Postprocessing SW: SEMCAD, V1.8 Build 186

Body Worn/Area Scan (10x15x1): Measurement grid: dx=15mm, dy=15mm

Maximum value of SAR (measured) = 0.340 mW/g

Body Worn/Zoom Scan (7x7x7)/Cube 0: Measurement grid: dx=5mm, dy=5mm, dz=5mm

Reference Value = 17.1 V/m; Power Drift = 0.030 dB

Peak SAR (extrapolated) = 0.403 W/kg

SAR(1 g) = 0.322 mW/g; SAR(10 g) = 0.241 mW/g

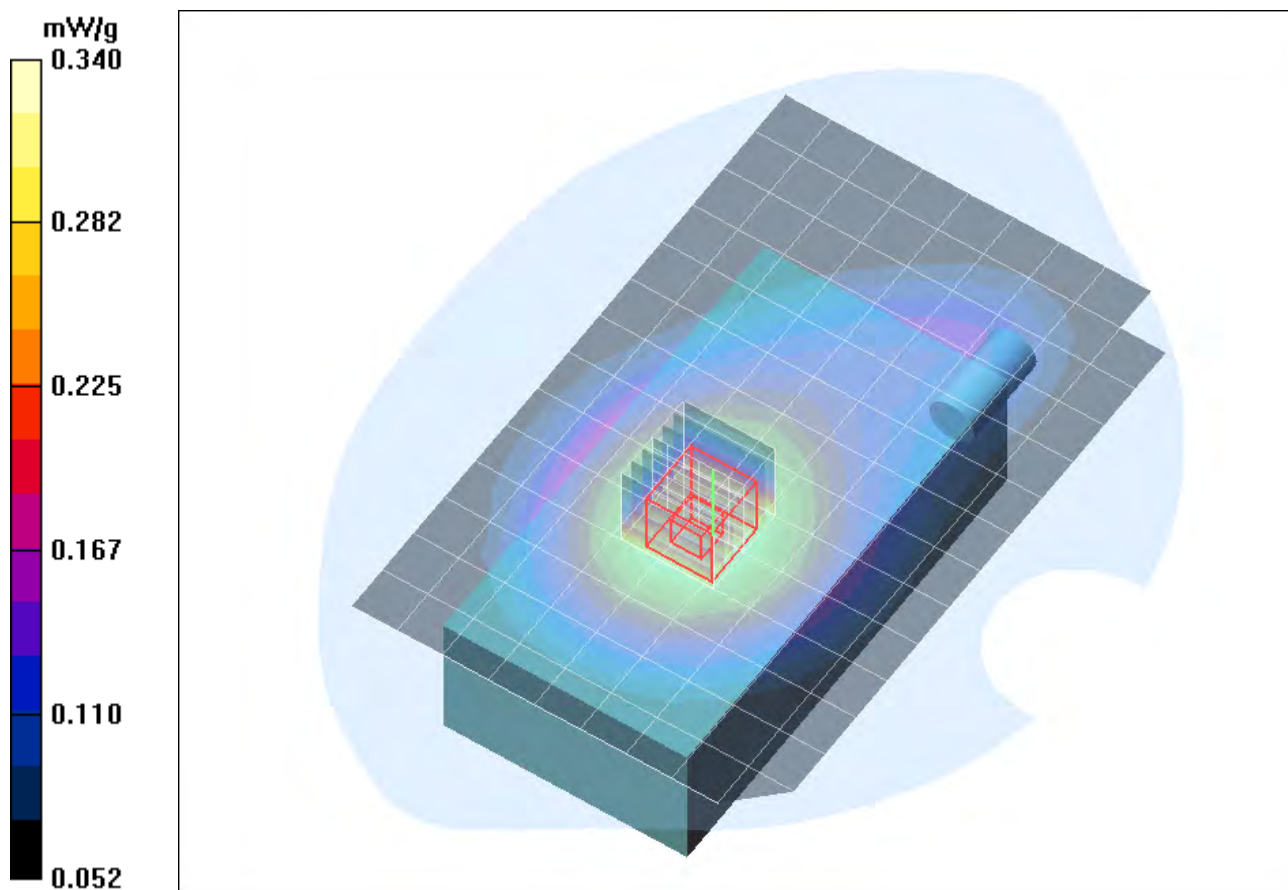

Fig. 25: SAR distribution for WCDMA V, channel 4183, body worn configuration, display towards the phantom, headset attached, 15 mm distance (July 26, 2010; Ambient Temperature: 21.2° C; Liquid Temperature: 20.7° C).

Test Laboratory: IMST GmbH, DASY Blue (I); File Name:
[680_buVhm_1_dspl_up_HSDPA_15mm.da4](#)

DUT: Datalogic ; Type: ELF; Serial: 354114011832680
 Program Name: WCDMA V

Communication System: WCDMA (FDD) Band V; Frequency: 836.5 MHz; Duty Cycle: 1:1
 Medium parameters used: $f = 836.6$ MHz; $\sigma = 0.99$ mho/m; $\epsilon_r = 53.3$; $\rho = 1000$ kg/m³
 Phantom section: Flat Section

DASY4 Configuration:

- Probe: ET3DV6R - SN1579; ConvF(6.21, 6.21, 6.21); Calibrated: 20.01.2010
- Sensor-Surface: 4mm (Mechanical Surface Detection)
- Electronics: DAE4 Sn631; Calibrated: 14.09.2009
- Phantom: SAM Sugar 1059; Type: Speag; Serial: 1059
- Measurement SW: DASY4, V4.7 Build 80; Postprocessing SW: SEMCAD, V1.8 Build 186

Body Worn/Area Scan (10x15x1): Measurement grid: dx=15mm, dy=15mm

Maximum value of SAR (measured) = 0.335 mW/g

Body Worn/Zoom Scan (7x7x7)/Cube 0: Measurement grid: dx=5mm, dy=5mm, dz=5mm

Reference Value = 16.3 V/m; Power Drift = 0.151 dB

Peak SAR (extrapolated) = 0.393 W/kg

SAR(1 g) = 0.315 mW/g; SAR(10 g) = 0.236 mW/g

Maximum value of SAR (measured) = 0.332 mW/g

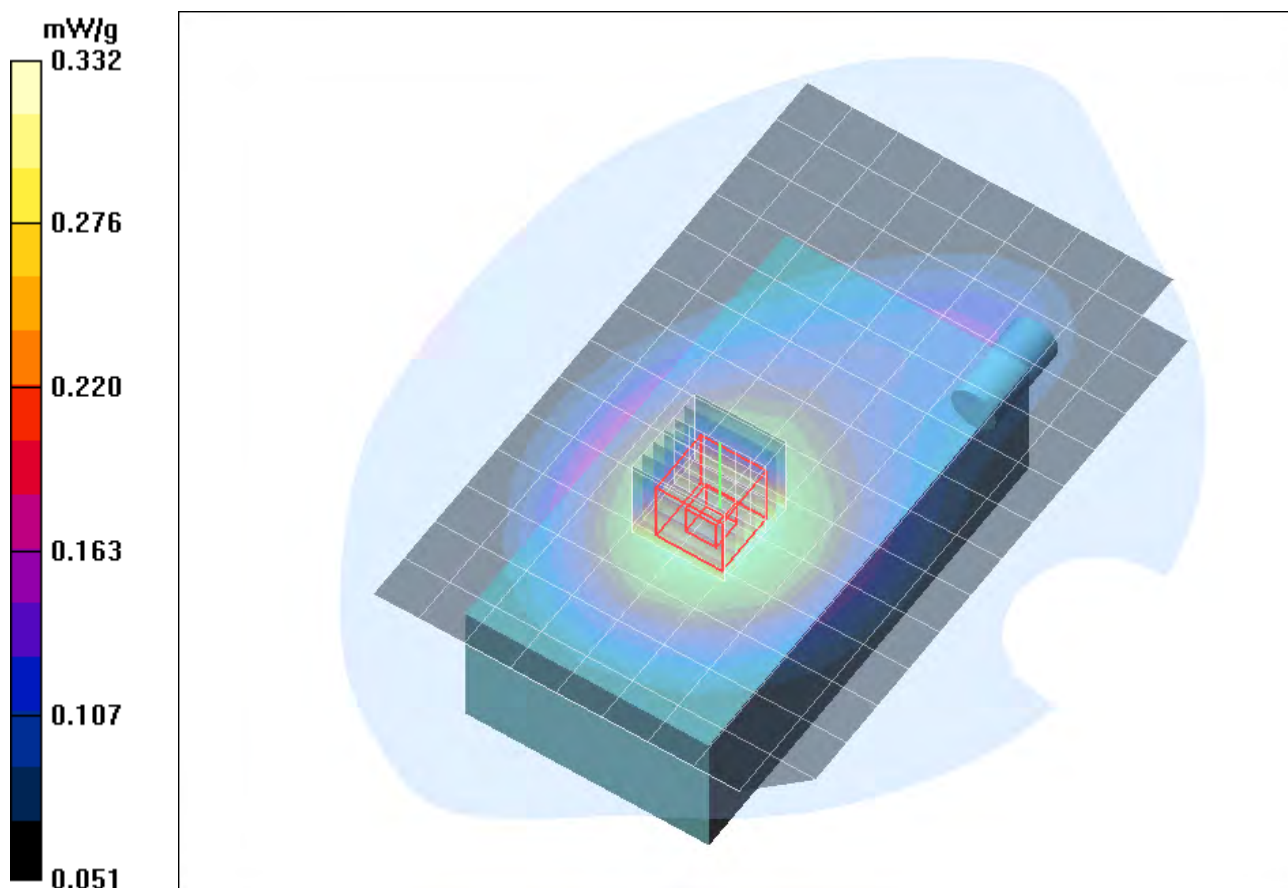

Fig. 26: SAR distribution for WCDMA V, channel 4183, body worn configuration, display towards the phantom, HSDPA, 15 mm distance (July 26, 2010; Ambient Temperature: 21.2° C; Liquid Temperature: 20.7° C).

7 SAR Distribution Plots, WCDMA II (FDD) Head

Test Laboratory: Imst GmbH, DASY Yellow (II); File Name: [680_yulllm_1.da4](#)

DUT: Datalogic ; Type: ELF; Serial: 354114011832680

Program Name: WCDMA II

Communication System: WCDMA FDD Band II; Frequency: 1880 MHz; Duty Cycle: 1:1

Medium parameters used: $f = 1880$ MHz; $\sigma = 1.41$ mho/m; $\epsilon_r = 39.8$; $\rho = 1000$ kg/m³

Phantom section: Left Section

DASY4 Configuration:

- Probe: EX3DV4 - SN3536; ConvF(7.95, 7.95, 7.95); Calibrated: 18.09.2009

- Sensor-Surface: 4mm (Mechanical Surface Detection)

- Electronics: DAE3 Sn335; Calibrated: 10.02.2010

- Phantom: SAM Glycol 1340; Type: QD 000 P40 CB; Serial: TP-1340

- Measurement SW: DASY4, V4.7 Build 80; Postprocessing SW: SEMCAD, V1.8 Build 186

Cheek Left/Area Scan (9x14x1): Measurement grid: dx=15mm, dy=15mm

Maximum value of SAR (measured) = 0.705 mW/g

Cheek Left/Zoom Scan (7x7x7)/Cube 0: Measurement grid: dx=5mm, dy=5mm, dz=5mm

Reference Value = 15.5 V/m; Power Drift = 0.104 dB

Peak SAR (extrapolated) = 1.35 W/kg

SAR(1 g) = 0.769 mW/g; SAR(10 g) = 0.430 mW/g

Maximum value of SAR (measured) = 0.837 mW/g

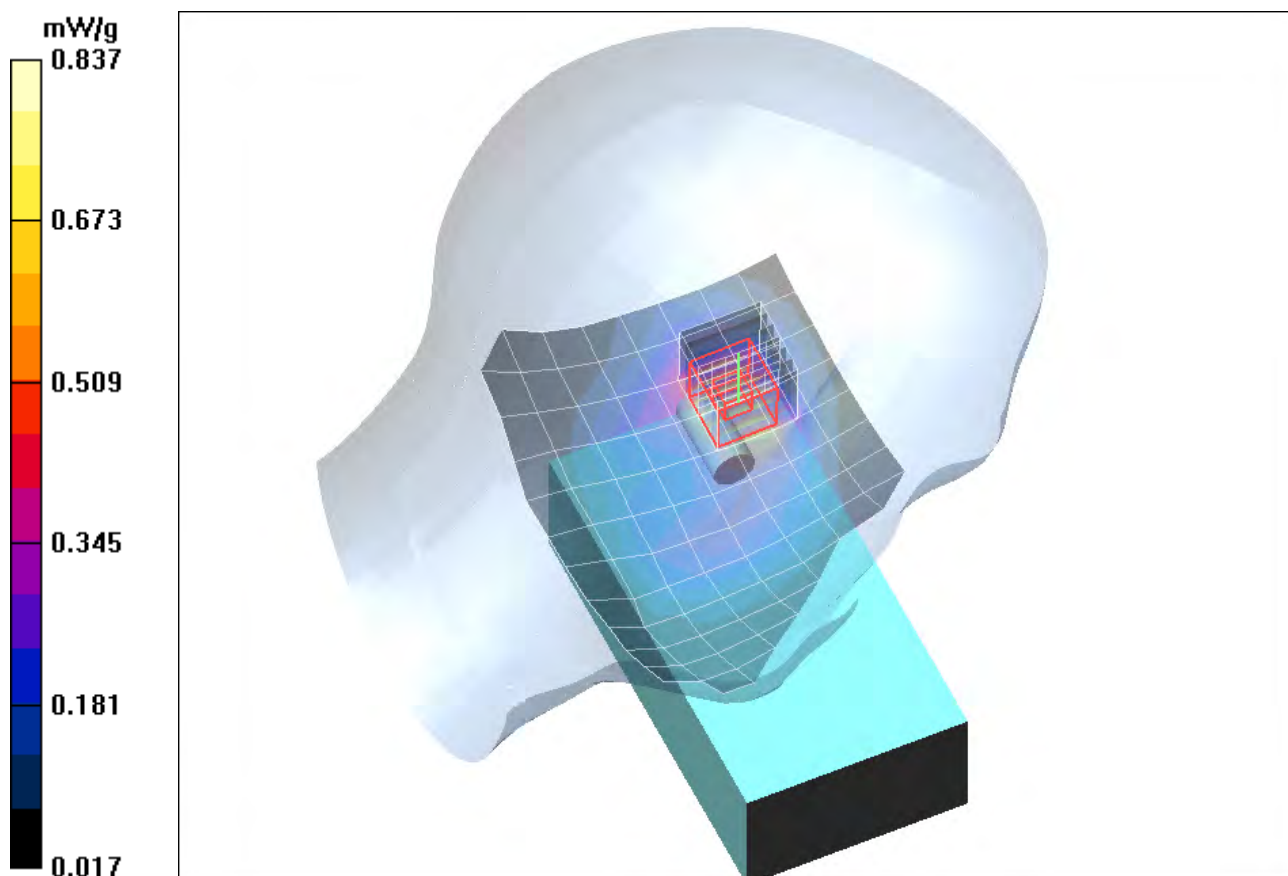

Fig. 27: SAR distribution for WCDMA II, channel 9400, cheek position, left side of head (July 12, 2010; Ambient Temperature: 21.4° C; Liquid Temperature: 20.8° C).

Test Laboratory: Imst GmbH, DASY Yellow (II); File Name: [680_yulllm_2.da4](#)

DUT: Datalogic ; Type: ELF; Serial: 354114011832680
Program Name: WCDMA II

Communication System: WCDMA FDD Band II; Frequency: 1880 MHz; Duty Cycle: 1:1
Medium parameters used: $f = 1880$ MHz; $\sigma = 1.41$ mho/m; $\epsilon_r = 39.8$; $\rho = 1000$ kg/m³
Phantom section: Left Section

DASY4 Configuration:

- Probe: EX3DV4 - SN3536; ConvF(7.95, 7.95, 7.95); Calibrated: 18.09.2009
- Sensor-Surface: 4mm (Mechanical Surface Detection)
- Electronics: DAE3 Sn335; Calibrated: 10.02.2010
- Phantom: SAM Glycol 1340; Type: QD 000 P40 CB; Serial: TP-1340
- Measurement SW: DASY4, V4.7 Build 80; Postprocessing SW: SEMCAD, V1.8 Build 186

Tilted Left/Area Scan (9x14x1): Measurement grid: dx=15mm, dy=15mm

Maximum value of SAR (measured) = 0.708 mW/g

Tilted Left/Zoom Scan (7x7x7)/Cube 0: Measurement grid: dx=5mm, dy=5mm, dz=5mm

Reference Value = 18.1 V/m; Power Drift = 0.003 dB

Peak SAR (extrapolated) = 1.58 W/kg

SAR(1 g) = 0.844 mW/g; SAR(10 g) = 0.447 mW/g

Maximum value of SAR (measured) = 0.949 mW/g

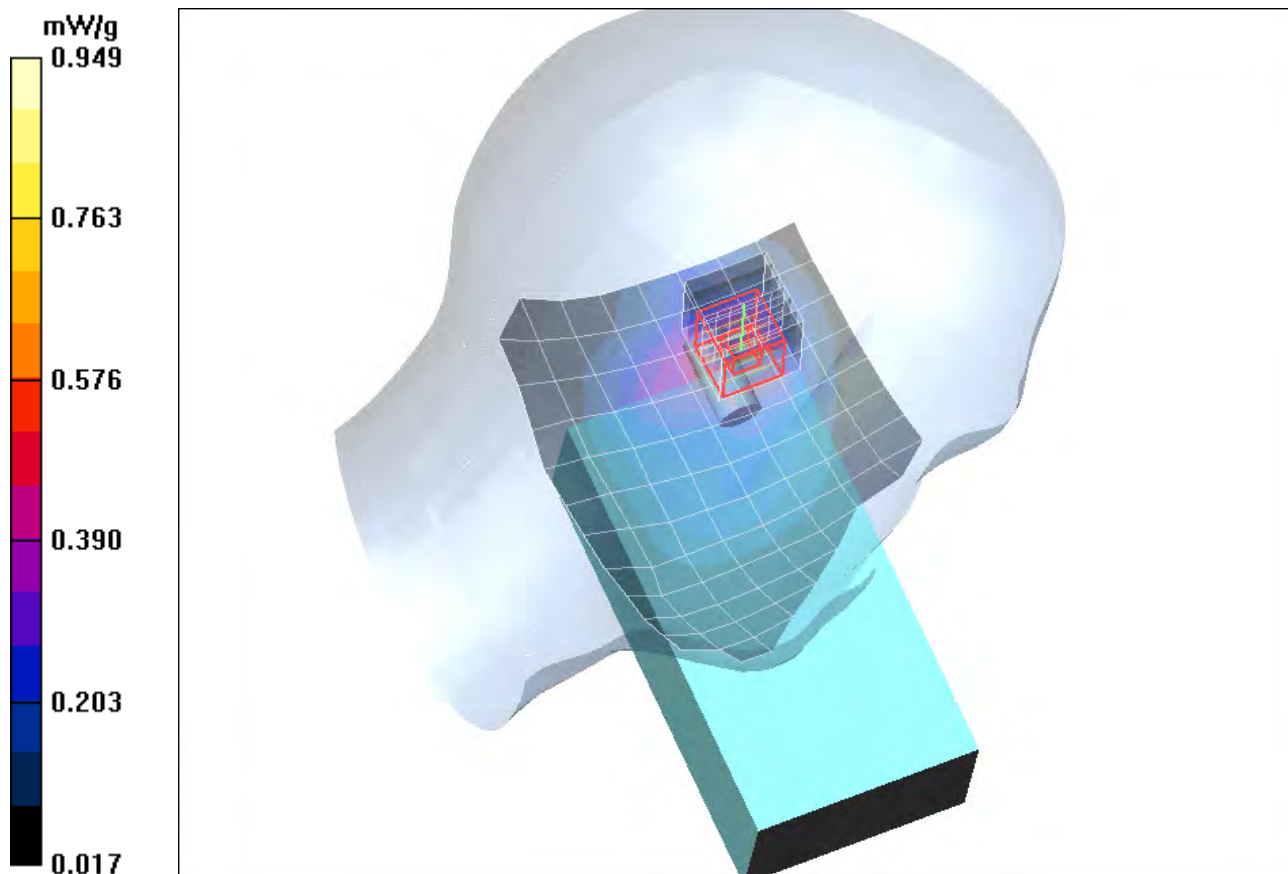

Fig. 28: SAR distribution for WCDMA II, channel 9400, tilted position, left side of head (July 12, 2010; Ambient Temperature: 21.4° C; Liquid Temperature: 20.8° C).

Test Laboratory: Imst GmbH, DASY Yellow (II); File Name: [680_yullrm_1.da4](#)

DUT: Datalogic ; Type: ELF; Serial: 354114011832680
 Program Name: WCDMA II

Communication System: WCDMA FDD Band II; Frequency: 1880 MHz; Duty Cycle: 1:1
 Medium parameters used: $f = 1880$ MHz; $\sigma = 1.41$ mho/m; $\epsilon_r = 39.8$; $\rho = 1000$ kg/m³
 Phantom section: Right Section

DASY4 Configuration:

- Probe: EX3DV4 - SN3536; ConvF(7.95, 7.95, 7.95); Calibrated: 18.09.2009
- Sensor-Surface: 4mm (Mechanical Surface Detection)
- Electronics: DAE3 Sn335; Calibrated: 10.02.2010
- Phantom: SAM Glycol 1340; Type: QD 000 P40 CB; Serial: TP-1340
- Measurement SW: DASY4, V4.7 Build 80; Postprocessing SW: SEMCAD, V1.8 Build 186

Cheek Right/Area Scan (9x14x1): Measurement grid: dx=15mm, dy=15mm

Maximum value of SAR (measured) = 0.489 mW/g

Cheek Right/Zoom Scan (7x7x7)/Cube 0: Measurement grid: dx=5mm, dy=5mm, dz=5mm

Reference Value = 17.1 V/m; Power Drift = 0.057 dB

Peak SAR (extrapolated) = 0.801 W/kg

SAR(1 g) = 0.457 mW/g; SAR(10 g) = 0.270 mW/g

Maximum value of SAR (measured) = 0.498 mW/g

Cheek Right/Zoom Scan (7x7x7)/Cube 1: Measurement grid: dx=5mm, dy=5mm, dz=5mm

Reference Value = 17.1 V/m; Power Drift = 0.057 dB

Peak SAR (extrapolated) = 0.661 W/kg

SAR(1 g) = 0.403 mW/g; SAR(10 g) = 0.253 mW/g

Maximum value of SAR (measured) = 0.434 mW/g

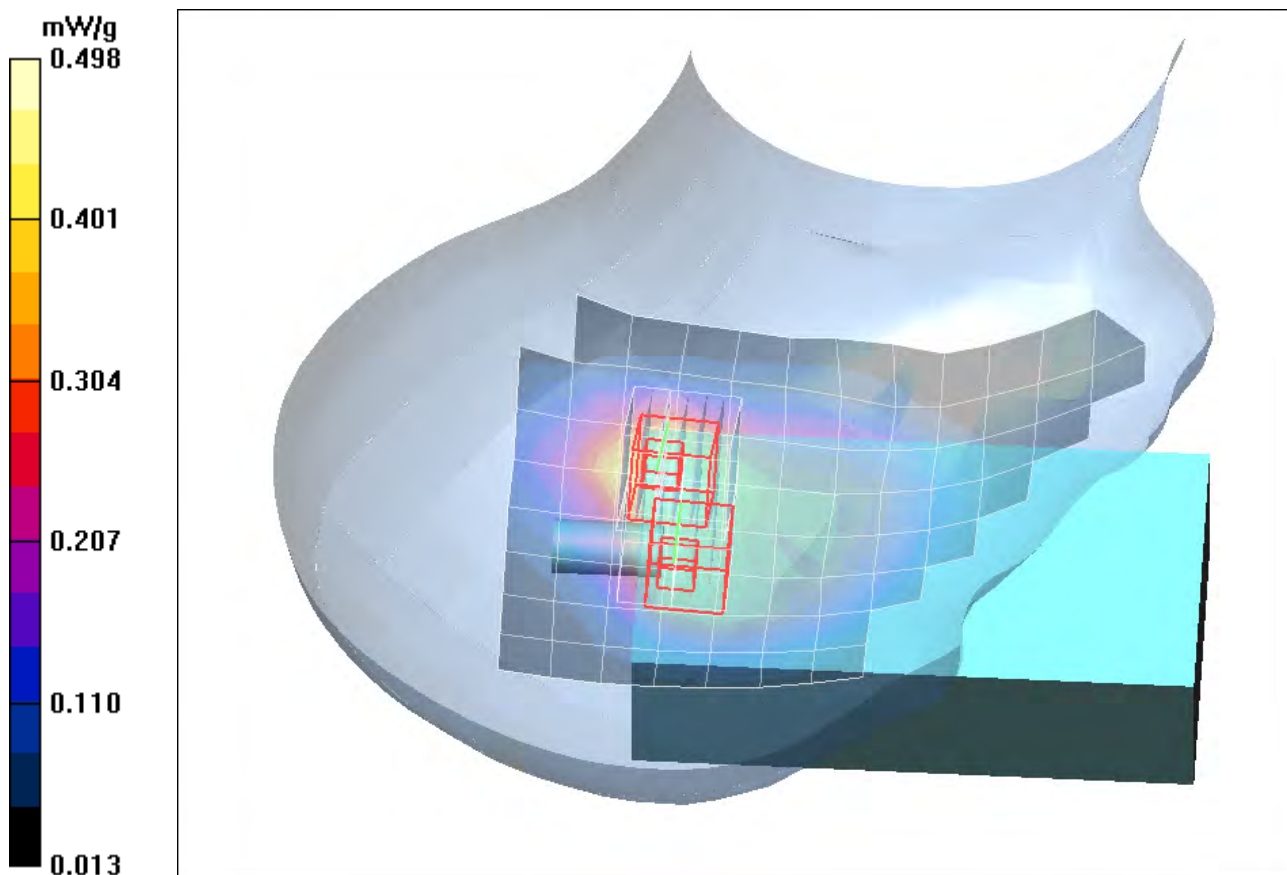

Fig. 29: SAR distribution for WCDMA II, channel 9400, cheek position, right side of head (July 12, 2010; Ambient Temperature: 21.4° C; Liquid Temperature: 20.8° C).

Test Laboratory: Imst GmbH, DASY Yellow (II); File Name: [680_yullrm_2.da4](#)

DUT: Datalogic ; Type: ELF; Serial: 354114011832680
Program Name: WCDMA II

Communication System: WCDMA FDD Band II; Frequency: 1880 MHz; Duty Cycle: 1:1
Medium parameters used: $f = 1880$ MHz; $\sigma = 1.41$ mho/m; $\epsilon_r = 39.8$; $\rho = 1000$ kg/m³
Phantom section: Right Section

DASY4 Configuration:

- Probe: EX3DV4 - SN3536; ConvF(7.95, 7.95, 7.95); Calibrated: 18.09.2009
- Sensor-Surface: 4mm (Mechanical Surface Detection)
- Electronics: DAE3 Sn335; Calibrated: 10.02.2010
- Phantom: SAM Glycol 1340; Type: QD 000 P40 CB; Serial: TP-1340
- Measurement SW: DASY4, V4.7 Build 80; Postprocessing SW: SEMCAD, V1.8 Build 186

Tilted Right/Area Scan (9x14x1): Measurement grid: dx=15mm, dy=15mm

Maximum value of SAR (measured) = 0.525 mW/g

Tilted Right/Zoom Scan (7x7x7)/Cube 0: Measurement grid: dx=5mm, dy=5mm, dz=5mm

Reference Value = 18.9 V/m; Power Drift = -0.007 dB

Peak SAR (extrapolated) = 0.834 W/kg

SAR(1 g) = 0.500 mW/g; SAR(10 g) = 0.299 mW/g

Maximum value of SAR (measured) = 0.542 mW/g

Tilted Right/Zoom Scan (7x7x7)/Cube 1: Measurement grid: dx=5mm, dy=5mm, dz=5mm

Reference Value = 18.9 V/m; Power Drift = -0.007 dB

Peak SAR (extrapolated) = 0.871 W/kg

SAR(1 g) = 0.502 mW/g; SAR(10 g) = 0.295 mW/g

Maximum value of SAR (measured) = 0.544 mW/g

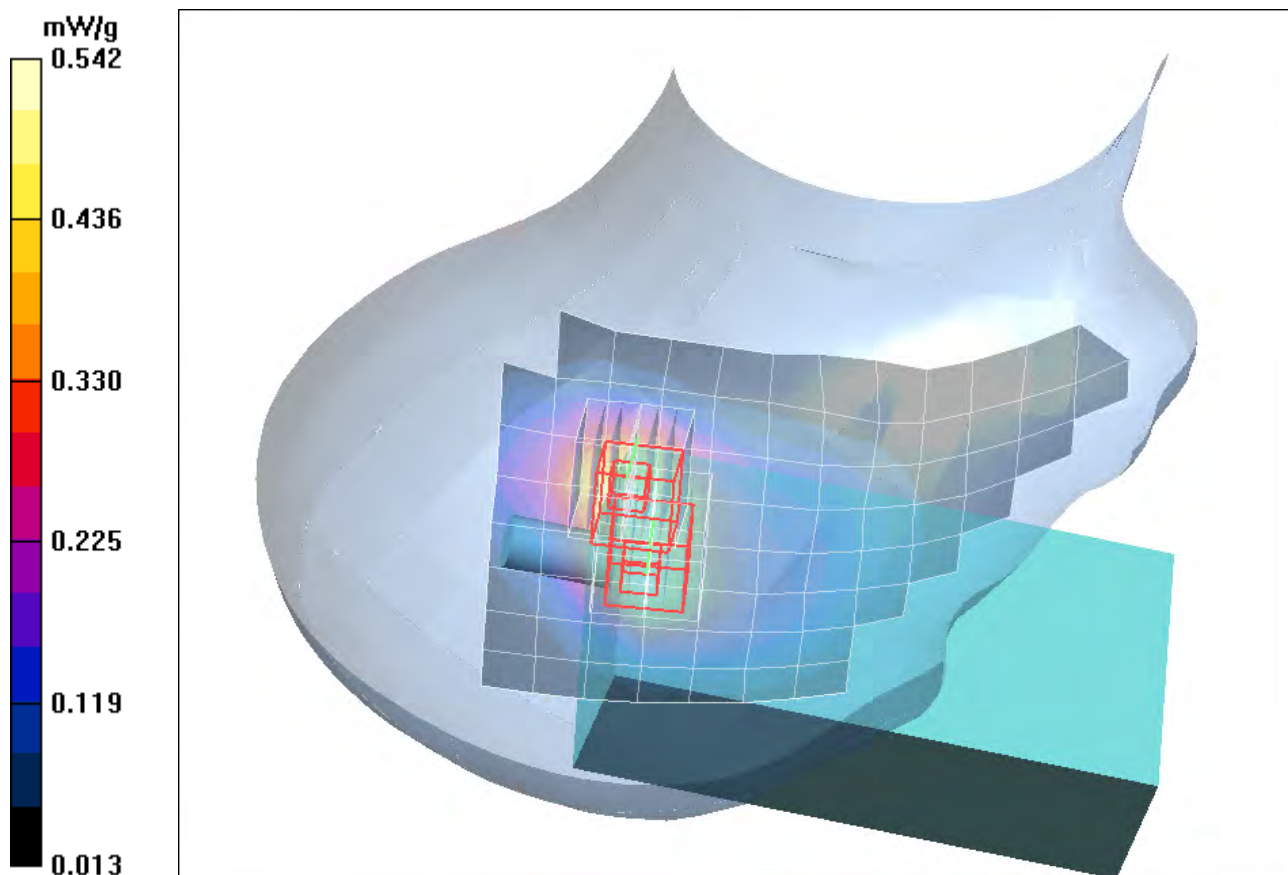

Fig. 30: SAR distribution for WCDMA II, channel 9400, tilted position, right side of head (July 12, 2010; Ambient Temperature: 21.4° C; Liquid Temperature: 20.8° C).

Test Laboratory: Imst GmbH, DASY Yellow (II); File Name: [680_yulIII_2.da4](#)

DUT: Datalogic ; Type: ELF; Serial: 354114011832680
Program Name: WCDMA II

Communication System: WCDMA FDD Band II; Frequency: 1852.4 MHz; Duty Cycle: 1:1
Medium parameters used: $f = 1852.4$ MHz; $\sigma = 1.37$ mho/m; $\epsilon_r = 39.9$; $\rho = 1000$ kg/m³
Phantom section: Left Section

DASY4 Configuration:

- Probe: EX3DV4 - SN3536; ConvF(7.95, 7.95, 7.95); Calibrated: 18.09.2009
- Sensor-Surface: 4mm (Mechanical Surface Detection)
- Electronics: DAE3 Sn335; Calibrated: 10.02.2010
- Phantom: SAM Glycol 1340; Type: QD 000 P40 CB; Serial: TP-1340
- Measurement SW: DASY4, V4.7 Build 80; Postprocessing SW: SEMCAD, V1.8 Build 186

Tilted Left/Area Scan (9x14x1): Measurement grid: dx=15mm, dy=15mm

Maximum value of SAR (measured) = 0.567 mW/g

Tilted Left/Zoom Scan (7x7x7)/Cube 0: Measurement grid: dx=5mm, dy=5mm, dz=5mm

Reference Value = 14.7 V/m; Power Drift = 0.095 dB

Peak SAR (extrapolated) = 1.00 W/kg

SAR(1 g) = 0.545 mW/g; SAR(10 g) = 0.289 mW/g

Maximum value of SAR (measured) = 0.605 mW/g

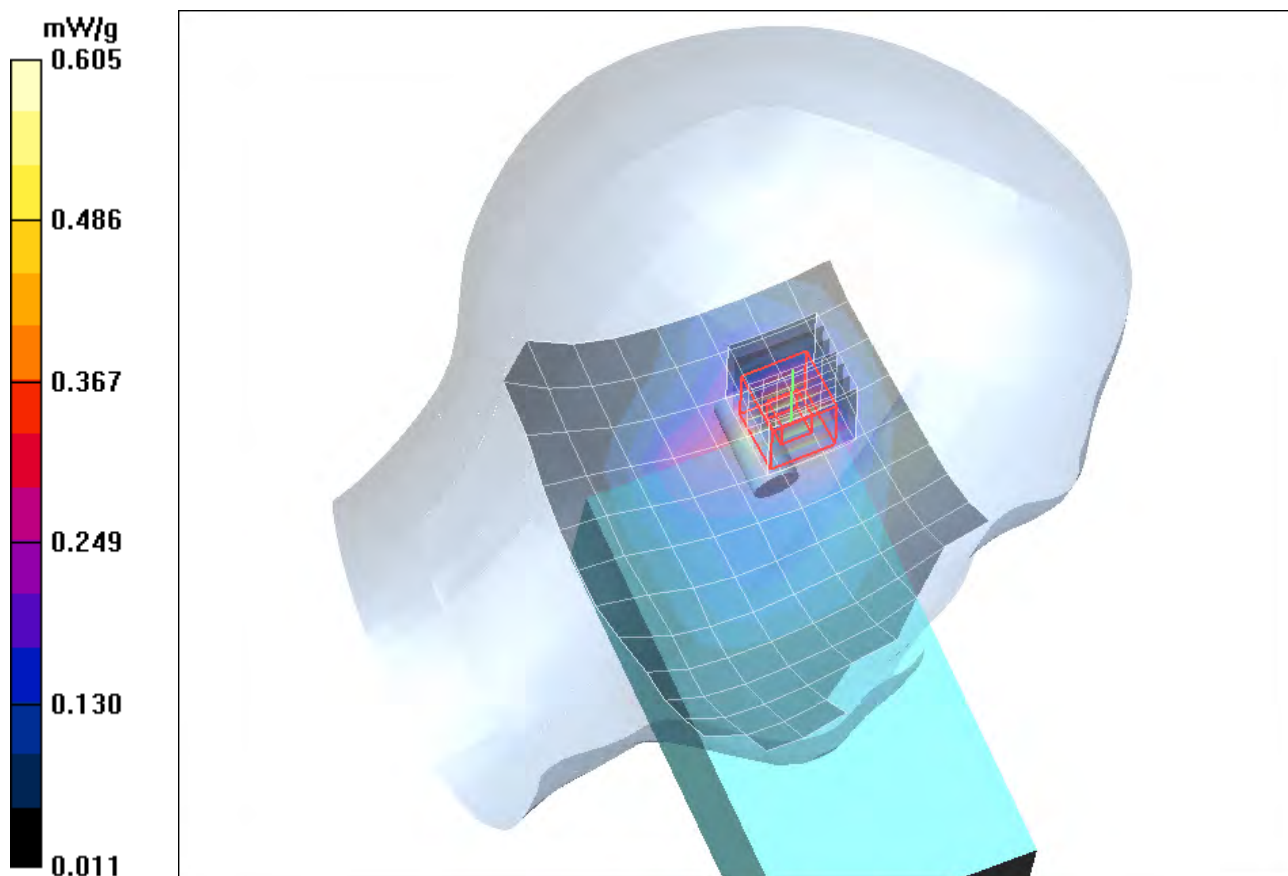

Fig. 31: SAR distribution for WCDMA II, channel 9262, tilted position, left side of head (July 12, 2010; Ambient Temperature: 21.4° C; Liquid Temperature: 20.8° C).

Test Laboratory: Imst GmbH, DASY Yellow (II); File Name: [680_yulllh_2.da4](#)

DUT: Datalogic ; Type: ELF; Serial: 354114011832680
Program Name: WCDMA II

Communication System: WCDMA FDD Band II; Frequency: 1907.6 MHz; Duty Cycle: 1:1
Medium parameters used: $f = 1907.6$ MHz; $\sigma = 1.44$ mho/m; $\epsilon_r = 39.7$; $\rho = 1000$ kg/m³
Phantom section: Left Section

DASY4 Configuration:

- Probe: EX3DV4 - SN3536; ConvF(7.95, 7.95, 7.95); Calibrated: 18.09.2009
- Sensor-Surface: 4mm (Mechanical Surface Detection)
- Electronics: DAE3 Sn335; Calibrated: 10.02.2010
- Phantom: SAM Glycol 1340; Type: QD 000 P40 CB; Serial: TP-1340
- Measurement SW: DASY4, V4.7 Build 80; Postprocessing SW: SEMCAD, V1.8 Build 186

Tilted Left/Area Scan (9x14x1): Measurement grid: dx=15mm, dy=15mm

Maximum value of SAR (measured) = 0.882 mW/g

Tilted Left/Zoom Scan (7x7x7)/Cube 0: Measurement grid: dx=5mm, dy=5mm, dz=5mm

Reference Value = 18.3 V/m; Power Drift = 0.091 dB

Peak SAR (extrapolated) = 1.68 W/kg

SAR(1 g) = 0.897 mW/g; SAR(10 g) = 0.477 mW/g

Maximum value of SAR (measured) = 1.00 mW/g

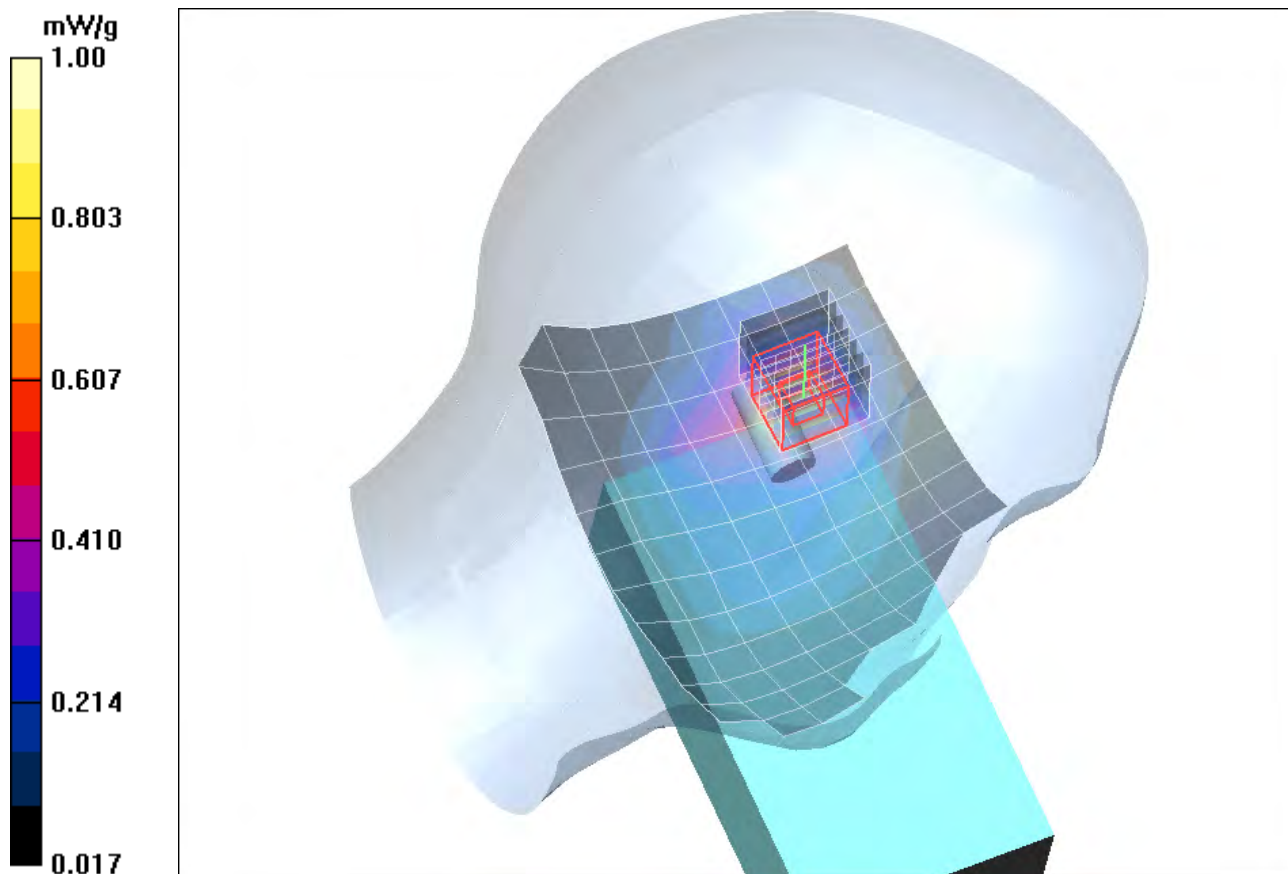

Fig. 32: SAR distribution for WCDMA II, channel 9538, tilted position, left side of head (July 12, 2010; Ambient Temperature: 21.4° C; Liquid Temperature: 20.8° C).

8 SAR Distribution Plots, WCDMA II (FDD) Body

Test Laboratory: Imst GmbH, DASY Yellow (II); File Name: [680_yullhm_1_dspl_up_15mm.da4](#)

DUT: Datalogic ; Type: ELF; Serial: 354114011832680

Program Name: WCDMA II

Communication System: WCDMA FDD Band II; Frequency: 1880 MHz; Duty Cycle: 1:1

Medium parameters used: $f = 1880$ MHz; $\sigma = 1.52$ mho/m; $\epsilon_r = 53.1$; $\rho = 1000$ kg/m³

Phantom section: Flat Section

DASY4 Configuration:

- Probe: EX3DV4 - SN3536; ConvF(8.11, 8.11, 8.11); Calibrated: 18.09.2009

- Sensor-Surface: 4mm (Mechanical Surface Detection)

- Electronics: DAE3 Sn335; Calibrated: 10.02.2010

- Phantom: SAM Glycol 1340; Type: QD 000 P40 CB; Serial: TP-1340

- Measurement SW: DASY4, V4.7 Build 80; Postprocessing SW: SEMCAD, V1.8 Build 186

Body Worn/Area Scan (10x15x1): Measurement grid: dx=15mm, dy=15mm

Maximum value of SAR (measured) = 0.141 mW/g

Body Worn/Zoom Scan (7x7x7)/Cube 0: Measurement grid: dx=5mm, dy=5mm, dz=5mm

Reference Value = 9.22 V/m; Power Drift = 0.033 dB

Peak SAR (extrapolated) = 0.224 W/kg

SAR(1 g) = 0.138 mW/g; SAR(10 g) = 0.084 mW/g

Maximum value of SAR (measured) = 0.150 mW/g

Body Worn/Zoom Scan (7x7x7)/Cube 1: Measurement grid: dx=5mm, dy=5mm, dz=5mm

Reference Value = 9.22 V/m; Power Drift = 0.033 dB

Peak SAR (extrapolated) = 0.197 W/kg

SAR(1 g) = 0.130 mW/g; SAR(10 g) = 0.085 mW/g

Maximum value of SAR (measured) = 0.140 mW/g

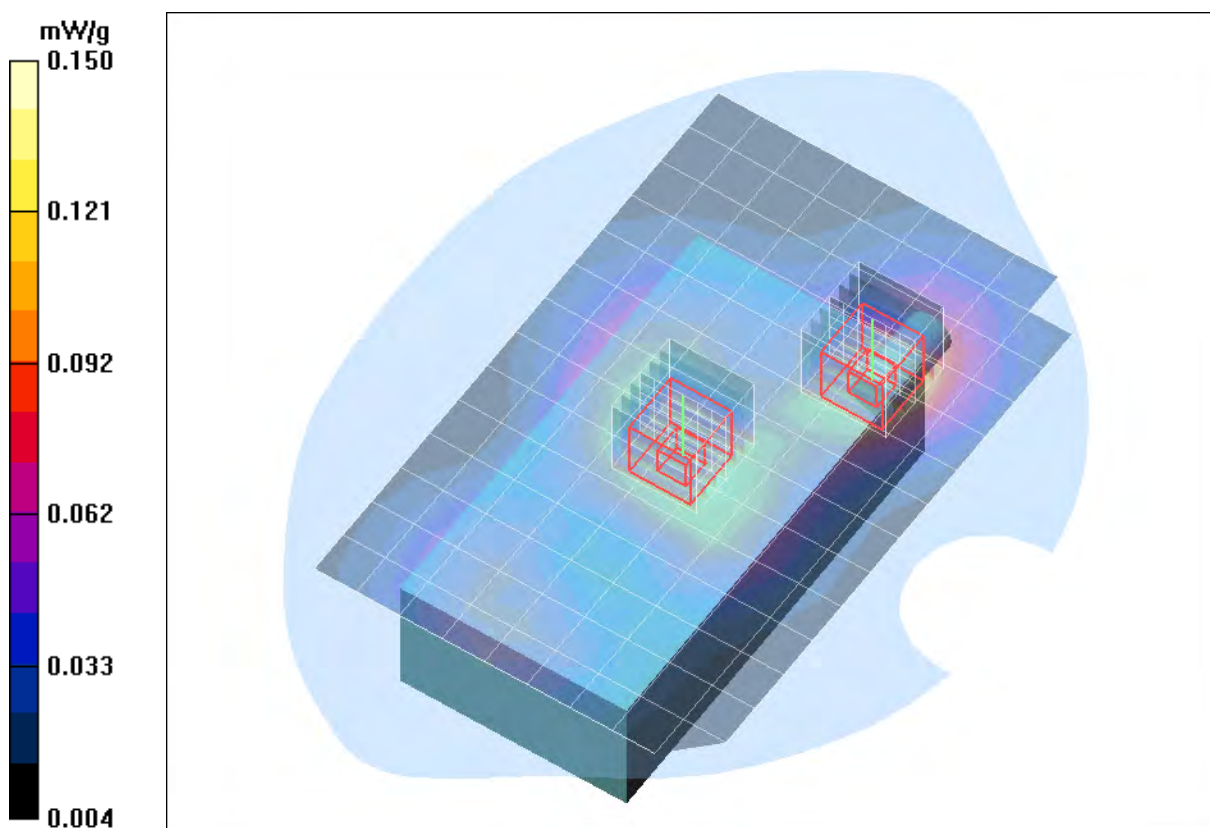

Fig. 33: SAR distribution for WCDMA II, channel 9400, body worn configuration, display towards the phantom, 15 mm distance (July 21, 2010; Ambient Temperature: 21.2° C; Liquid Temperature: 20.6° C).

Test Laboratory: Imst GmbH, DASY Yellow (II); File Name: [680_yullhm_2_dspl_down_15mm.da4](#)

DUT: Datalogic ; Type: ELF; Serial: 354114011832680
Program Name: WCDMA II

Communication System: WCDMA FDD Band II; Frequency: 1880 MHz; Duty Cycle: 1:1
Medium parameters used: $f = 1880$ MHz; $\sigma = 1.52$ mho/m; $\epsilon_r = 53.1$; $\rho = 1000$ kg/m³
Phantom section: Flat Section

DASY4 Configuration:

- Probe: EX3DV4 - SN3536; ConvF(8.11, 8.11, 8.11); Calibrated: 18.09.2009
- Sensor-Surface: 4mm (Mechanical Surface Detection)
- Electronics: DAE3 Sn335; Calibrated: 10.02.2010
- Phantom: SAM Glycol 1340; Type: QD 000 P40 CB; Serial: TP-1340
- Measurement SW: DASY4, V4.7 Build 80; Postprocessing SW: SEMCAD, V1.8 Build 186

Body Worn/Area Scan (10x15x1): Measurement grid: dx=15mm, dy=15mm

Maximum value of SAR (measured) = 0.245 mW/g

Body Worn/Zoom Scan (7x7x7)/Cube 0: Measurement grid: dx=5mm, dy=5mm, dz=5mm

Reference Value = 9.07 V/m; Power Drift = 0.115 dB

Peak SAR (extrapolated) = 0.366 W/kg

SAR(1 g) = 0.230 mW/g; SAR(10 g) = 0.144 mW/g

Maximum value of SAR (measured) = 0.250 mW/g

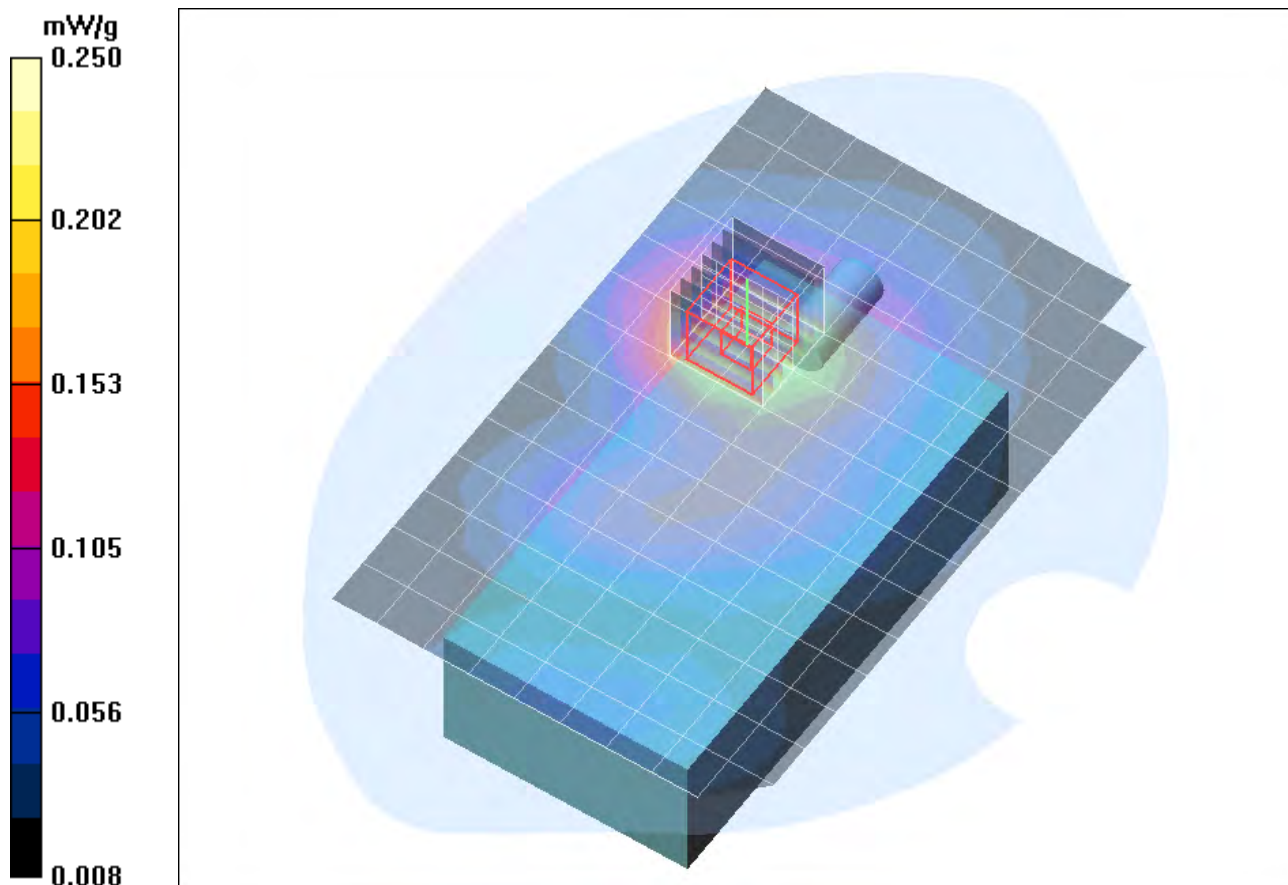

Fig. 34: SAR distribution for WCDMA II, channel 9400, body worn configuration, display towards the ground, 15 mm distance (July 21, 2010; Ambient Temperature: 21.2° C; Liquid Temperature: 20.6° C).

Test Laboratory: Imst GmbH, DASY Yellow (II); File Name:
[680_yullhm_3_dspl_down_HS_15mm.da4](#)

DUT: Datalogic ; Type: ELF; Serial: 354114011832680
 Program Name: WCDMA II

Communication System: WCDMA FDD Band II; Frequency: 1880 MHz; Duty Cycle: 1:1
 Medium parameters used: $f = 1880$ MHz; $\sigma = 1.52$ mho/m; $\epsilon_r = 53.1$; $\rho = 1000$ kg/m³
 Phantom section: Flat Section

DASY4 Configuration:

- Probe: EX3DV4 - SN3536; ConvF(8.11, 8.11, 8.11); Calibrated: 18.09.2009
- Sensor-Surface: 4mm (Mechanical Surface Detection)
- Electronics: DAE3 Sn335; Calibrated: 10.02.2010
- Phantom: SAM Glycol 1340; Type: QD 000 P40 CB; Serial: TP-1340
- Measurement SW: DASY4, V4.7 Build 80; Postprocessing SW: SEMCAD, V1.8 Build 186

Body Worn/Area Scan (10x15x1): Measurement grid: dx=15mm, dy=15mm

Maximum value of SAR (measured) = 0.229 mW/g

Body Worn/Zoom Scan (7x7x7)/Cube 0: Measurement grid: dx=5mm, dy=5mm, dz=5mm

Reference Value = 8.70 V/m; Power Drift = 0.135 dB

Peak SAR (extrapolated) = 0.350 W/kg

SAR(1 g) = 0.223 mW/g; SAR(10 g) = 0.140 mW/g

Maximum value of SAR (measured) = 0.237 mW/g

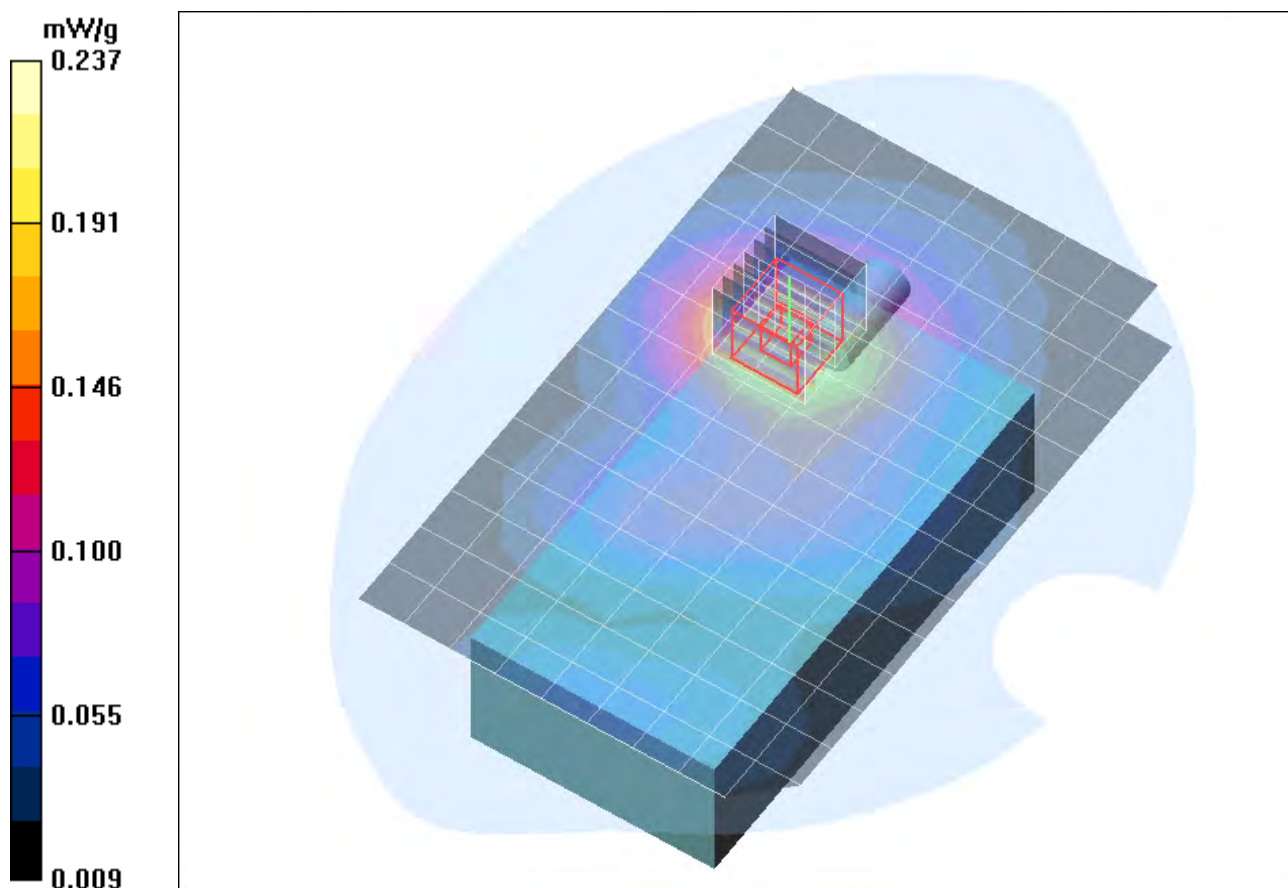

Fig. 35: SAR distribution for WCDMA II, channel 9400, body worn configuration, display towards the ground, headset attached, 15 mm distance (July 21, 2010; Ambient Temperature: 21.2° C; Liquid Temperature: 20.6° C).

Test Laboratory: IMST GmbH, DASY Blue (I); File Name:
[680_yullhm_2_dspl_down_HSDPA_15mm.da4](#)

DUT: Datalogic ; Type: ELF; Serial: 354114011832680
 Program Name: WCDMA II

Communication System: WCDMA FDD Band II; Frequency: 1880 MHz; Duty Cycle: 1:1
 Medium parameters used: $f = 1880$ MHz; $\sigma = 1.52$ mho/m; $\epsilon_r = 53.1$; $\rho = 1000$ kg/m³
 Phantom section: Flat Section

DASY4 Configuration:

- Probe: EX3DV4 - SN3536; ConvF(8.11, 8.11, 8.11); Calibrated: 18.09.2009
- Sensor-Surface: 4mm (Mechanical Surface Detection)
- Electronics: DAE3 Sn335; Calibrated: 10.02.2010
- Phantom: SAM Glycol 1340; Type: QD 000 P40 CB; Serial: TP-1340
- Measurement SW: DASY4, V4.7 Build 80; Postprocessing SW: SEMCAD, V1.8 Build 186

Body Worn/Area Scan (10x15x1): Measurement grid: $dx=15$ mm, $dy=15$ mm

Maximum value of SAR (measured) = 0.225 mW/g

Body Worn/Zoom Scan (7x7x7)/Cube 0: Measurement grid: $dx=5$ mm, $dy=5$ mm, $dz=5$ mm

Reference Value = 9.05 V/m; Power Drift = 0.196 dB

Peak SAR (extrapolated) = 0.350 W/kg

SAR(1 g) = 0.221 mW/g; SAR(10 g) = 0.138 mW/g

Maximum value of SAR (measured) = 0.237 mW/g

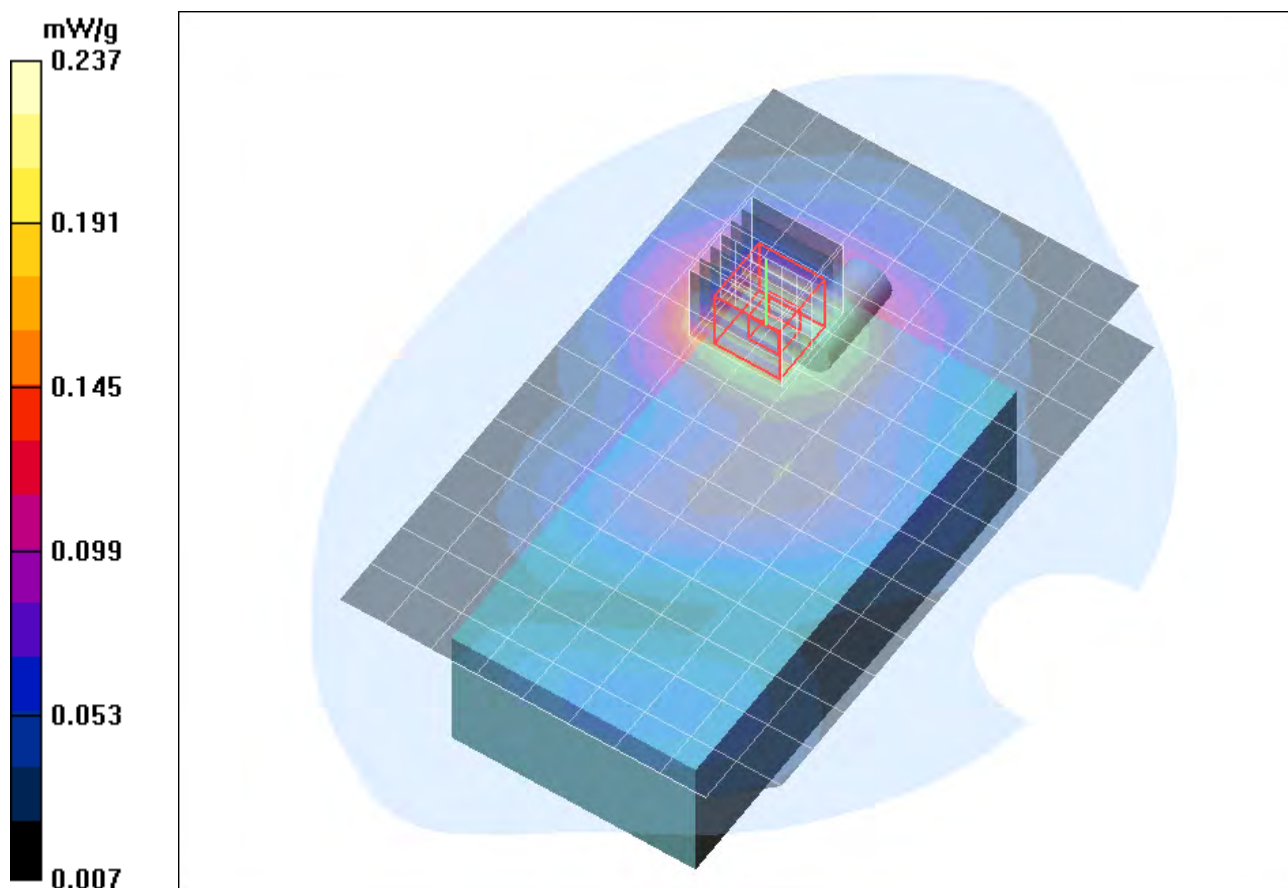

Fig. 36: SAR distribution for WCDMA II, channel 9400, body worn configuration, display towards the ground, HSDPA, 15 mm distance (July 21, 2010; Ambient Temperature: 21.2° C; Liquid Temperature: 20.6° C).

9 SAR Distribution Plots, IEEE 802.11 b Head

Test Laboratory: Imst GmbH, DASY Yellow (II); File Name: [ELF_ywlm_1_ch6_b.da4](#)

DUT: Datalogic; Type: Elf 701-701; Serial: D10P00071

Program Name: IEEE 802.11 b

Communication System: WLAN 2450; Frequency: 2437 MHz; Duty Cycle: 1:1

Medium parameters used: $f = 2437$ MHz; $\sigma = 1.81$ mho/m; $\epsilon_r = 38.7$; $\rho = 1000$ kg/m³

Phantom section: Left Section

DASY4 Configuration:

- Probe: EX3DV4 - SN3536; ConvF(7.59, 7.59, 7.59); Calibrated: 18.09.2009

- Sensor-Surface: 4mm (Mechanical Surface Detection)

- Electronics: DAE3 Sn335; Calibrated: 10.02.2010

- Phantom: SAM Glycol 1340; Type: QD 000 P40 CB; Serial: TP-1340

- Measurement SW: DASY4, V4.7 Build 80; Postprocessing SW: SEMCAD, V1.8 Build 186

Cheek Left/Area Scan (10x14x1): Measurement grid: dx=15mm, dy=15mm

Maximum value of SAR (measured) = 0.073 mW/g

Cheek Left/Zoom Scan (7x7x7)/Cube 0: Measurement grid: dx=5mm, dy=5mm, dz=5mm

Reference Value = 4.41 V/m; Power Drift = 0.028 dB

Peak SAR (extrapolated) = 0.115 W/kg

SAR(1 g) = 0.064 mW/g; SAR(10 g) = 0.032 mW/g

Maximum value of SAR (measured) = 0.074 mW/g

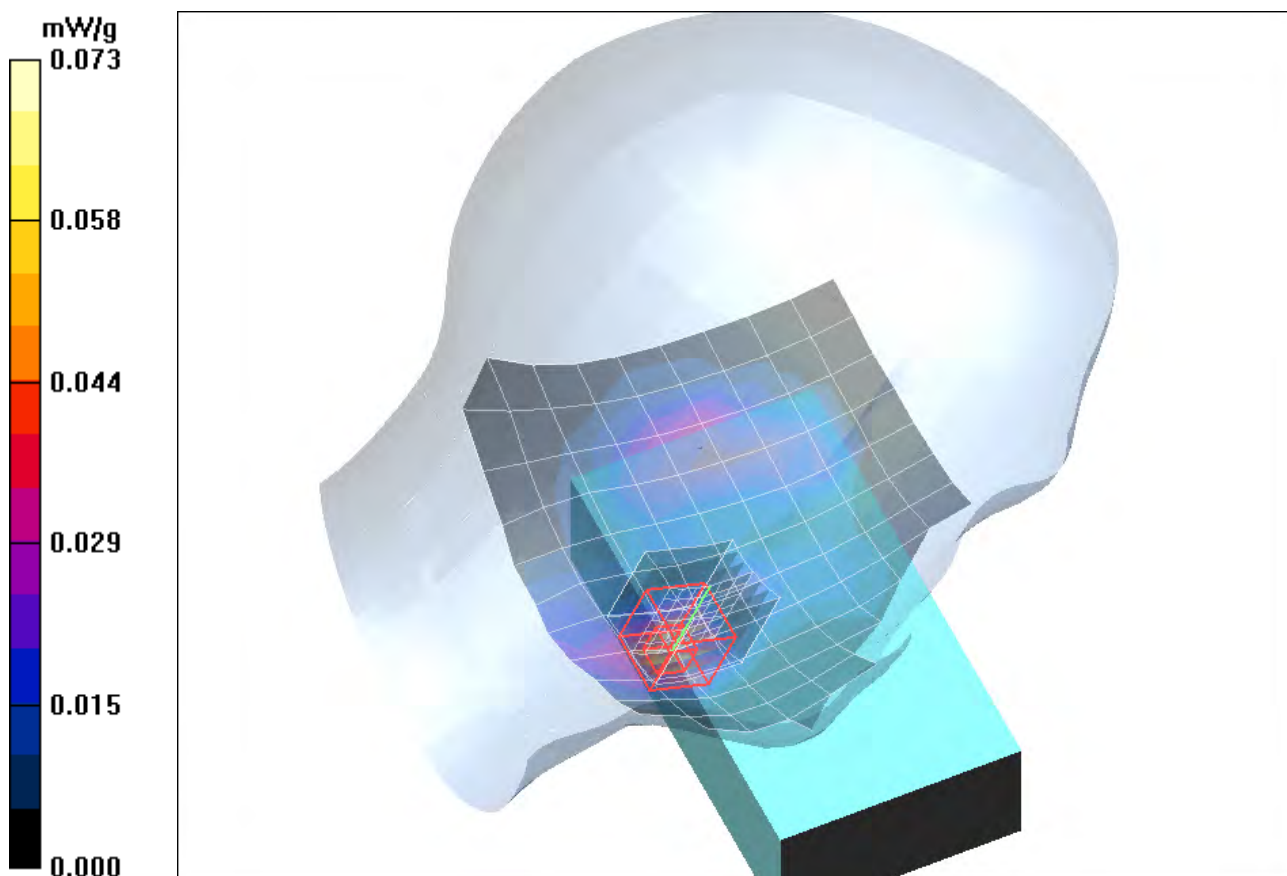

Fig. 37: SAR distribution for IEEE 802.11 b, channel 6, cheek position, left side of head (July 28, 2010; Ambient Temperature: 21.5° C; Liquid Temperature: 21.1° C).

Test Laboratory: Imst GmbH, DASY Yellow (II); File Name: [ELF_ywlm_2_ch6_b.da4](#)

DUT: Datalogic; Type: Elf 701-701; Serial: D10P00071

Program Name: IEEE 802.11 b

Communication System: WLAN 2450; Frequency: 2437 MHz; Duty Cycle: 1:1
 Medium parameters used: $f = 2437$ MHz; $\sigma = 1.81$ mho/m; $\epsilon_r = 38.7$; $\rho = 1000$ kg/m³
 Phantom section: Left Section

DASY4 Configuration:

- Probe: EX3DV4 - SN3536; ConvF(7.59, 7.59, 7.59); Calibrated: 18.09.2009
- Sensor-Surface: 4mm (Mechanical Surface Detection)
- Electronics: DAE3 Sn335; Calibrated: 10.02.2010
- Phantom: SAM Glycol 1340; Type: QD 000 P40 CB; Serial: TP-1340
- Measurement SW: DASY4, V4.7 Build 80; Postprocessing SW: SEMCAD, V1.8 Build 186

Tilted Left/Area Scan (10x14x1): Measurement grid: dx=15mm, dy=15mm

Maximum value of SAR (measured) = 0.038 mW/g

Tilted Left/Zoom Scan (7x7x7)/Cube 0: Measurement grid: dx=5mm, dy=5mm, dz=5mm

Reference Value = 4.92 V/m; Power Drift = -0.044 dB

Peak SAR (extrapolated) = 0.084 W/kg

SAR(1 g) = 0.045 mW/g; SAR(10 g) = 0.022 mW/g

Maximum value of SAR (measured) = 0.050 mW/g

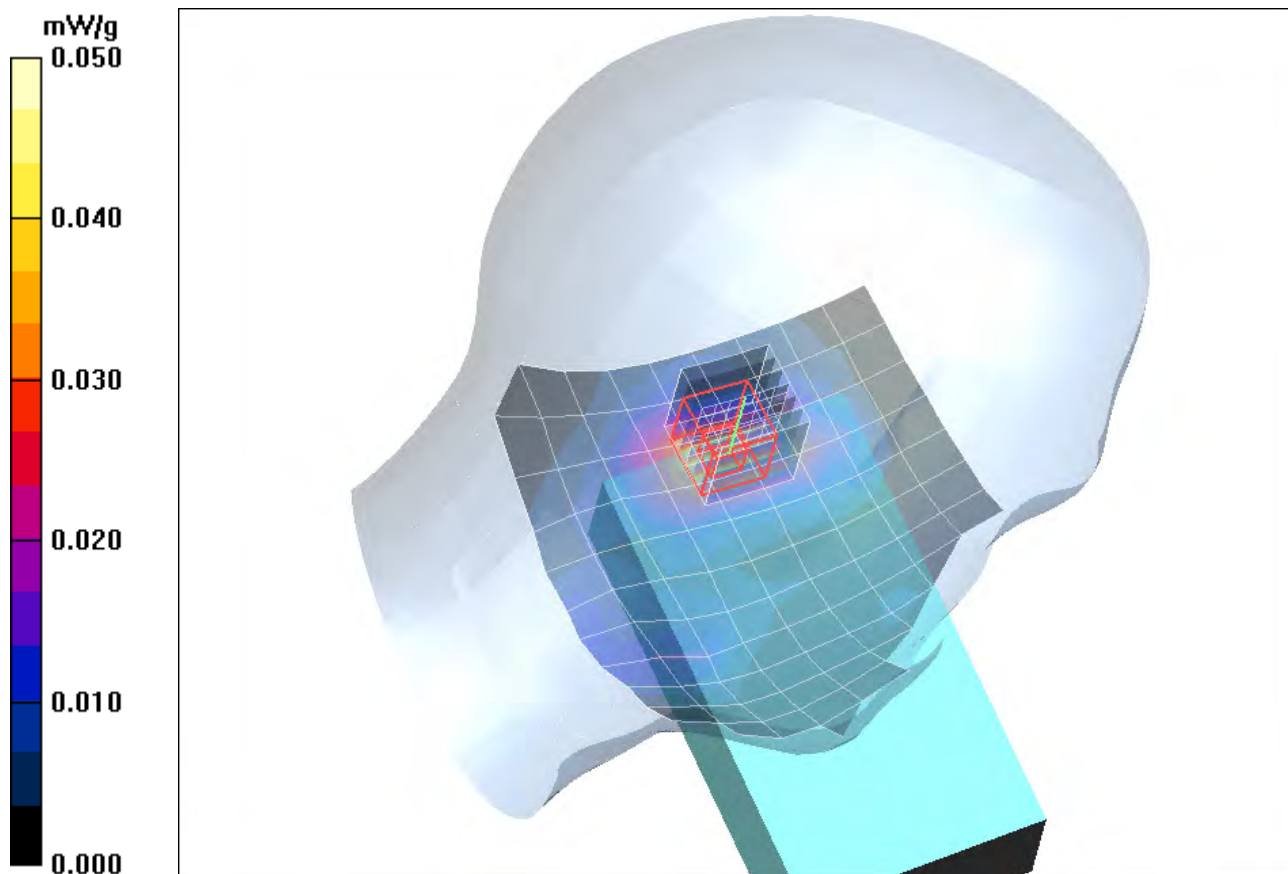

Fig. 38: SAR distribution for IEEE 802.11 b, channel 6, tilted position, left side of head (July 28, 2010; Ambient Temperature: 21.5° C; Liquid Temperature: 21.1° C).

Test Laboratory: Imst GmbH, DASY Yellow (II); File Name: [ELF_ywrm_1_ch6_b.da4](#)

DUT: Datalogic; Type: Elf 701-701; Serial: D10P00071

Program Name: IEEE 802.11 b

Communication System: WLAN 2450; Frequency: 2437 MHz; Duty Cycle: 1:1

Medium parameters used: $f = 2437$ MHz; $\sigma = 1.81$ mho/m; $\epsilon_r = 38.7$; $\rho = 1000$ kg/m³

Phantom section: Right Section

DASY4 Configuration:

- Probe: EX3DV4 - SN3536; ConvF(7.59, 7.59, 7.59); Calibrated: 18.09.2009

- Sensor-Surface: 4mm (Mechanical Surface Detection)

- Electronics: DAE3 Sn335; Calibrated: 10.02.2010

- Phantom: SAM Glycol 1340; Type: QD 000 P40 CB; Serial: TP-1340

- Measurement SW: DASY4, V4.7 Build 80; Postprocessing SW: SEMCAD, V1.8 Build 186

Cheek Right/Area Scan (10x13x1): Measurement grid: $dx=15$ mm, $dy=15$ mm

Maximum value of SAR (measured) = 0.052 mW/g

Cheek Right/Zoom Scan (7x7x7)/Cube 0: Measurement grid: $dx=5$ mm, $dy=5$ mm, $dz=5$ mm

Reference Value = 4.37 V/m; Power Drift = 0.082 dB

Peak SAR (extrapolated) = 0.087 W/kg

SAR(1 g) = 0.048 mW/g; SAR(10 g) = 0.026 mW/g

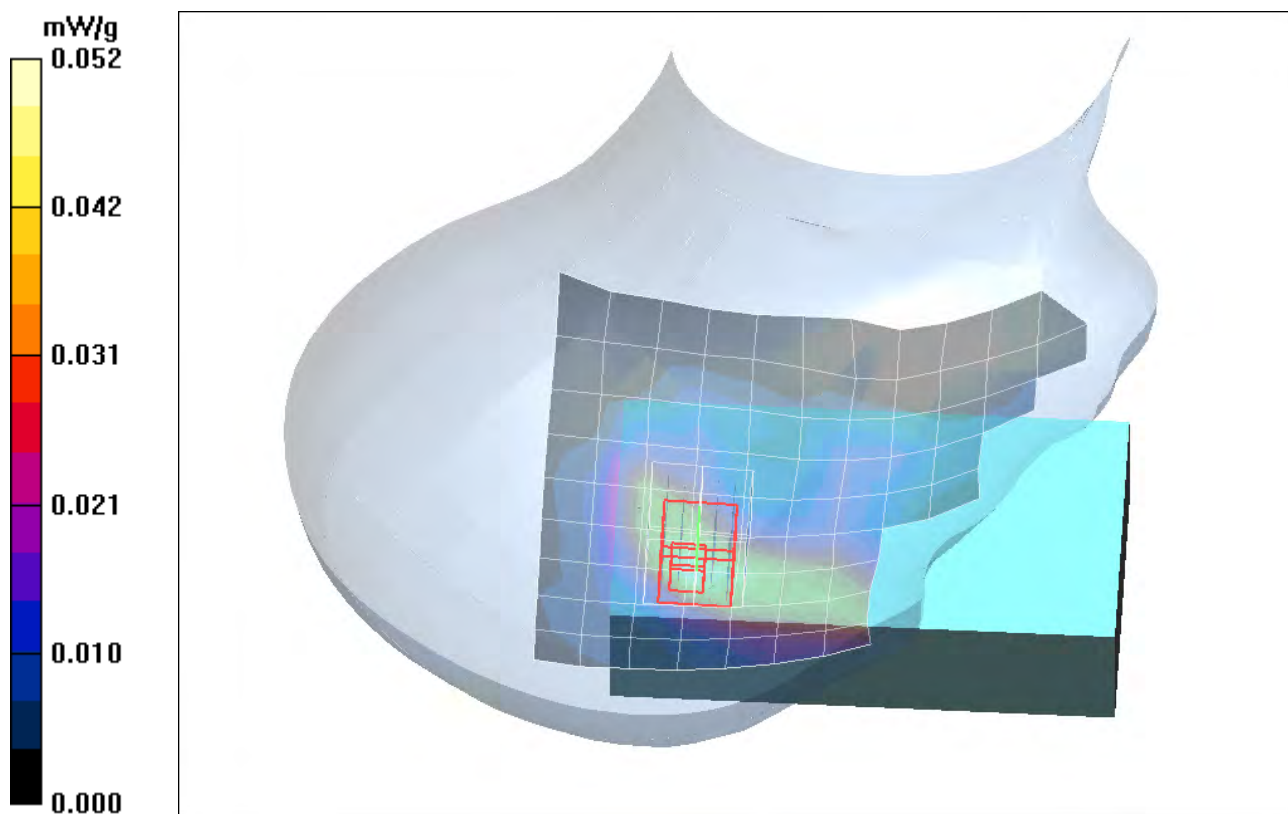

Fig. 39: SAR distribution for IEEE 802.11 b, channel 6, cheek position, right side of head (July 28, 2010; Ambient Temperature: 21.5° C; Liquid Temperature: 21.1° C).

Test Laboratory: Imst GmbH, DASY Yellow (II); File Name: [ELF_ywrm_2_ch6_b.da4](#)

DUT: Datalogic; Type: Elf 701-701; Serial: D10P00071

Program Name: IEEE 802.11 b

Communication System: WLAN 2450; Frequency: 2437 MHz; Duty Cycle: 1:1

Medium parameters used: $f = 2437$ MHz; $\sigma = 1.81$ mho/m; $\epsilon_r = 38.7$; $\rho = 1000$ kg/m³

Phantom section: Right Section

DASY4 Configuration:

- Probe: EX3DV4 - SN3536; ConvF(7.59, 7.59, 7.59); Calibrated: 18.09.2009

- Sensor-Surface: 4mm (Mechanical Surface Detection)

- Electronics: DAE3 Sn335; Calibrated: 10.02.2010

- Phantom: SAM Glycol 1340; Type: QD 000 P40 CB; Serial: TP-1340

- Measurement SW: DASY4, V4.7 Build 80; Postprocessing SW: SEMCAD, V1.8 Build 186

Tilted Right/Area Scan (10x13x1): Measurement grid: dx=15mm, dy=15mm

Maximum value of SAR (measured) = 0.041 mW/g

Tilted Right/Zoom Scan (7x7x7)/Cube 0: Measurement grid: dx=5mm, dy=5mm, dz=5mm

Reference Value = 4.69 V/m; Power Drift = 0.108 dB

Peak SAR (extrapolated) = 0.078 W/kg

SAR(1 g) = 0.041 mW/g; SAR(10 g) = 0.021 mW/g

Maximum value of SAR (measured) = 0.046 mW/g

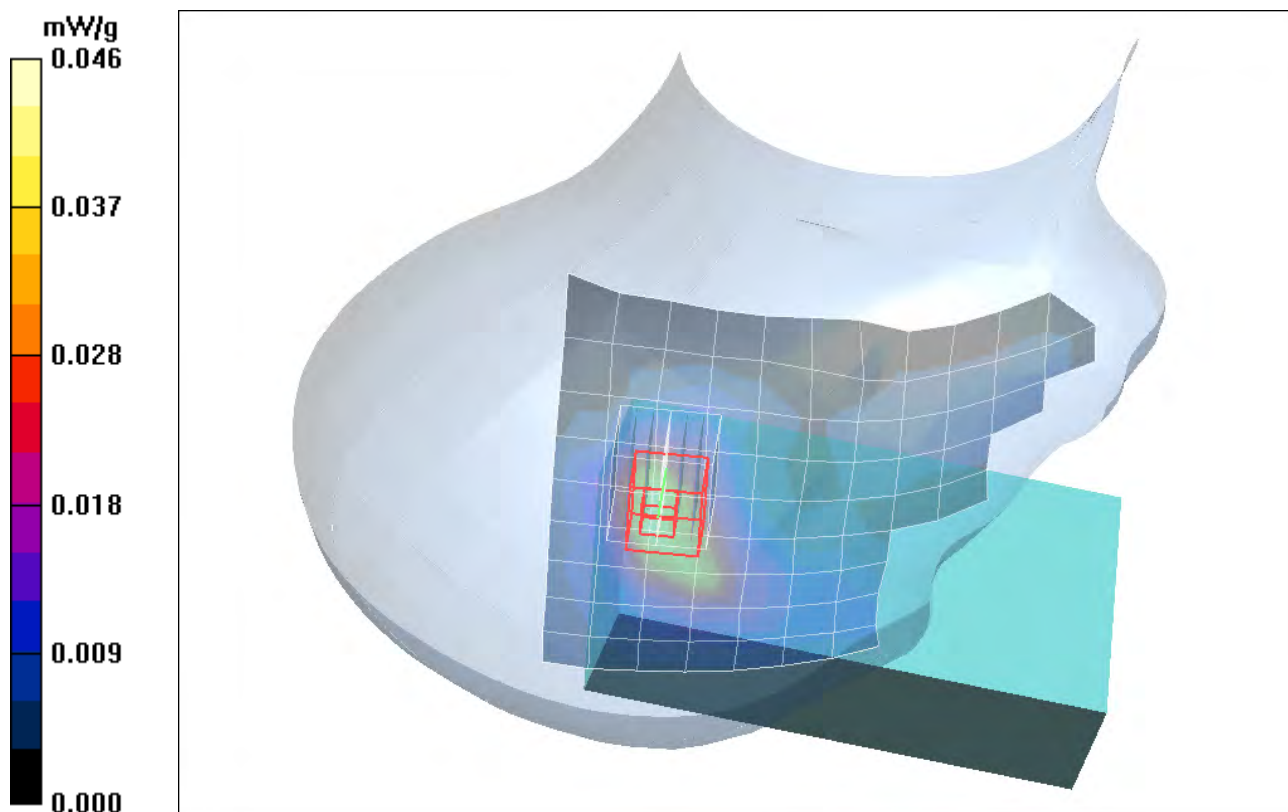

Fig. 40: SAR distribution for IEEE 802.11 b, channel 6, tilted position, right side of head (July 28, 2010; Ambient Temperature: 21.5° C; Liquid Temperature: 21.1° C).

10 SAR Distribution Plots, IEEE 802.11 b Body

Test Laboratory: Imst GmbH, DASY Yellow (II); File Name: [Elf_ywhm_b_CH6_dspl_up.da4](#)

DUT: Datalogic; Type: Elf 701-701; Serial: D10P00071

Program Name: WLAN

Communication System: WLAN 2450; Frequency: 2437 MHz; Duty Cycle: 1:1

Medium parameters used: $f = 2437$ MHz; $\sigma = 1.96$ mho/m; $\epsilon_r = 53.1$; $\rho = 1000$ kg/m³

Phantom section: Flat Section

DASY4 Configuration:

- Probe: EX3DV4 - SN3536; ConvF(7.57, 7.57, 7.57); Calibrated: 18.09.2009

- Sensor-Surface: 4mm (Mechanical Surface Detection)

- Electronics: DAE3 Sn335; Calibrated: 10.02.2010

- Phantom: SAM Glycol 1340; Type: QD 000 P40 CB; Serial: TP-1340

- Measurement SW: DASY4, V4.7 Build 80; Postprocessing SW: SEMCAD, V1.8 Build 186

Body Worn/Area Scan (16x19x1): Measurement grid: dx=10mm, dy=10mm

Maximum value of SAR (measured) = 0.023 mW/g

Body Worn/Zoom Scan (7x7x7)/Cube 0: Measurement grid: dx=5mm, dy=5mm, dz=5mm

Reference Value = 1.75 V/m; Power Drift = -0.139 dB

Peak SAR (extrapolated) = 0.047 W/kg

SAR(1 g) = 0.022 mW/g; SAR(10 g) = 0.012 mW/g

Maximum value of SAR (measured) = 0.024 mW/g

Body Worn/Zoom Scan (7x7x7)/Cube 1: Measurement grid: dx=5mm, dy=5mm, dz=5mm

Reference Value = 1.75 V/m; Power Drift = -0.139 dB

Peak SAR (extrapolated) = 0.039 W/kg

SAR(1 g) = 0.022 mW/g; SAR(10 g) = 0.010 mW/g

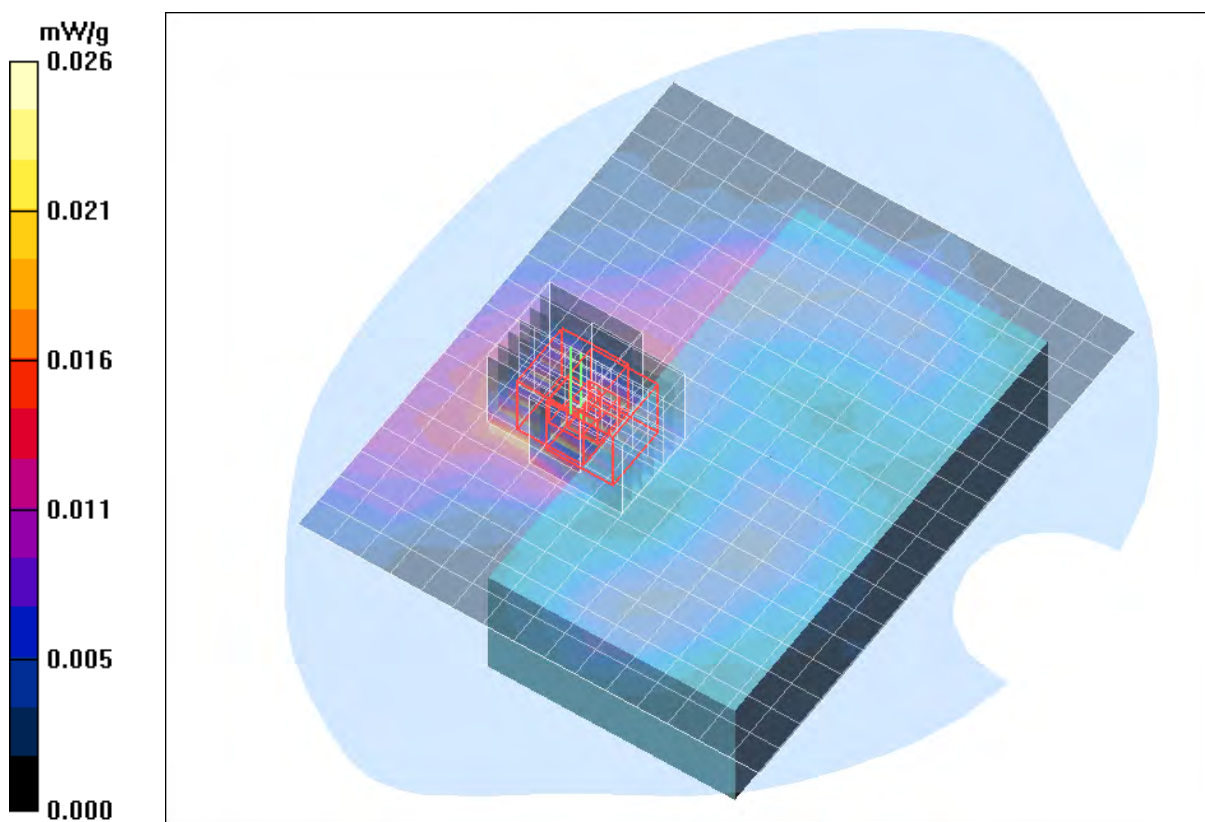

Fig. 41: SAR distribution for IEEE 802.11 b, channel 6, body worn configuration, display towards the phantom, 15 mm distance (May 11, 2010; Ambient Temperature: 21.9° C; Liquid Temperature: 21.5° C).

Test Laboratory: Imst GmbH, DASY Yellow (II); File Name: [Elf_ywhm_b_CH6_dspl_down.da4](#)

DUT: Datalogic; Type: Elf 701-701; Serial: D10P00071

Program Name: WLAN

Communication System: WLAN 2450; Frequency: 2437 MHz; Duty Cycle: 1:1
Medium parameters used: $f = 2437$ MHz; $\sigma = 1.96$ mho/m; $\epsilon_r = 53.1$; $\rho = 1000$ kg/m³
Phantom section: Flat Section

DASY4 Configuration:

- Probe: EX3DV4 - SN3536; ConvF(7.57, 7.57, 7.57); Calibrated: 18.09.2009
- Sensor-Surface: 4mm (Mechanical Surface Detection)
- Electronics: DAE3 Sn335; Calibrated: 10.02.2010
- Phantom: SAM Glycol 1340; Type: QD 000 P40 CB; Serial: TP-1340
- Measurement SW: DASY4, V4.7 Build 80; Postprocessing SW: SEMCAD, V1.8 Build 186

Body Worn/Area Scan (16x19x1): Measurement grid: $dx=10$ mm, $dy=10$ mm

Maximum value of SAR (measured) = 0.067 mW/g

Body Worn/Zoom Scan (7x7x7)/Cube 0: Measurement grid: $dx=5$ mm, $dy=5$ mm, $dz=5$ mm

Reference Value = 3.24 V/m; Power Drift = 0.134 dB

Peak SAR (extrapolated) = 0.113 W/kg

SAR(1 g) = 0.065 mW/g; SAR(10 g) = 0.036 mW/g

Maximum value of SAR (measured) = 0.072 mW/g

Body Worn/Zoom Scan (7x7x7)/Cube 1: Measurement grid: $dx=5$ mm, $dy=5$ mm, $dz=5$ mm

Reference Value = 3.24 V/m; Power Drift = 0.134 dB

Peak SAR (extrapolated) = 0.074 W/kg

SAR(1 g) = 0.042 mW/g; SAR(10 g) = 0.024 mW/g

Maximum value of SAR (measured) = 0.045 mW/g

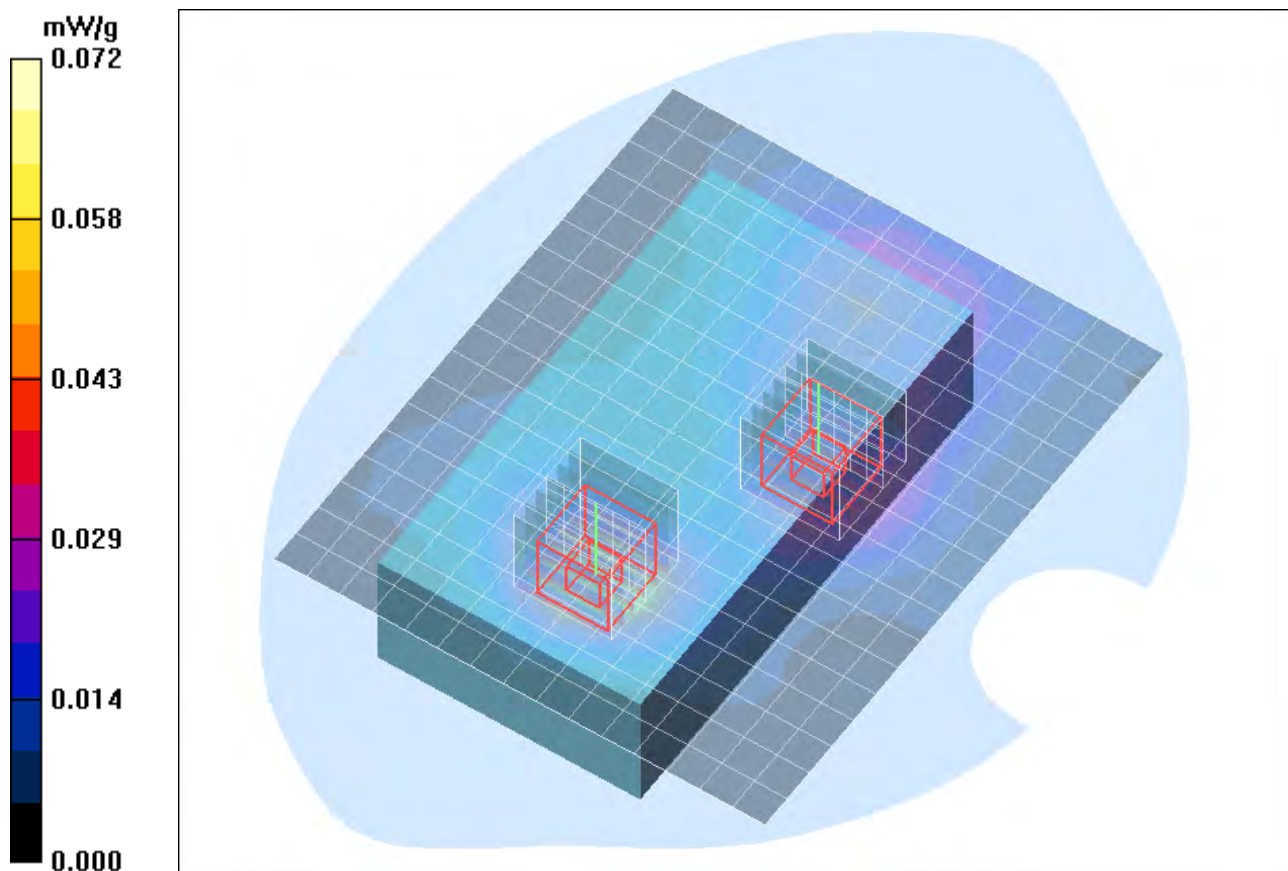

Fig. 42: SAR distribution for IEEE 802.11 b, channel 6, body worn configuration, display towards the ground, 15 mm distance (May 11, 2010; Ambient Temperature: 21.9° C; Liquid Temperature: 21.5° C).

11 SAR Distribution Plots, IEEE 802.11 g Head

Test Laboratory: Imst GmbH, DASY Yellow (II); File Name: [ELF_ywlm_1_ch6_g.da4](#)

DUT: Datalogic; Type: Elf 701-701; Serial: D10P00071

Program Name: IEEE 802.11 g

Communication System: WLAN 2450; Frequency: 2437 MHz; Duty Cycle: 1:1

Medium parameters used: $f = 2437$ MHz; $\sigma = 1.81$ mho/m; $\epsilon_r = 38.7$; $\rho = 1000$ kg/m³

Phantom section: Left Section

DASY4 Configuration:

- Probe: EX3DV4 - SN3536; ConvF(7.59, 7.59, 7.59); Calibrated: 18.09.2009

- Sensor-Surface: 4mm (Mechanical Surface Detection)

- Electronics: DAE3 Sn335; Calibrated: 10.02.2010

- Phantom: SAM Glycol 1340; Type: QD 000 P40 CB; Serial: TP-1340

- Measurement SW: DASY4, V4.7 Build 80; Postprocessing SW: SEMCAD, V1.8 Build 186

Cheek Left/Area Scan (10x14x1): Measurement grid: dx=15mm, dy=15mm

Maximum value of SAR (measured) = 0.083 mW/g

Cheek Left/Zoom Scan (7x7x7)/Cube 0: Measurement grid: dx=5mm, dy=5mm, dz=5mm

Reference Value = 5.06 V/m; Power Drift = 0.173 dB

Peak SAR (extrapolated) = 0.130 W/kg

SAR(1 g) = 0.072 mW/g; SAR(10 g) = 0.037 mW/g

Maximum value of SAR (measured) = 0.081 mW/g

Cheek Left/Zoom Scan (7x7x7)/Cube 1: Measurement grid: dx=5mm, dy=5mm, dz=5mm

Reference Value = 5.06 V/m; Power Drift = 0.173 dB

Peak SAR (extrapolated) = 0.093 W/kg

SAR(1 g) = 0.050 mW/g; SAR(10 g) = 0.026 mW/g

Maximum value of SAR (measured) = 0.056 mW/g

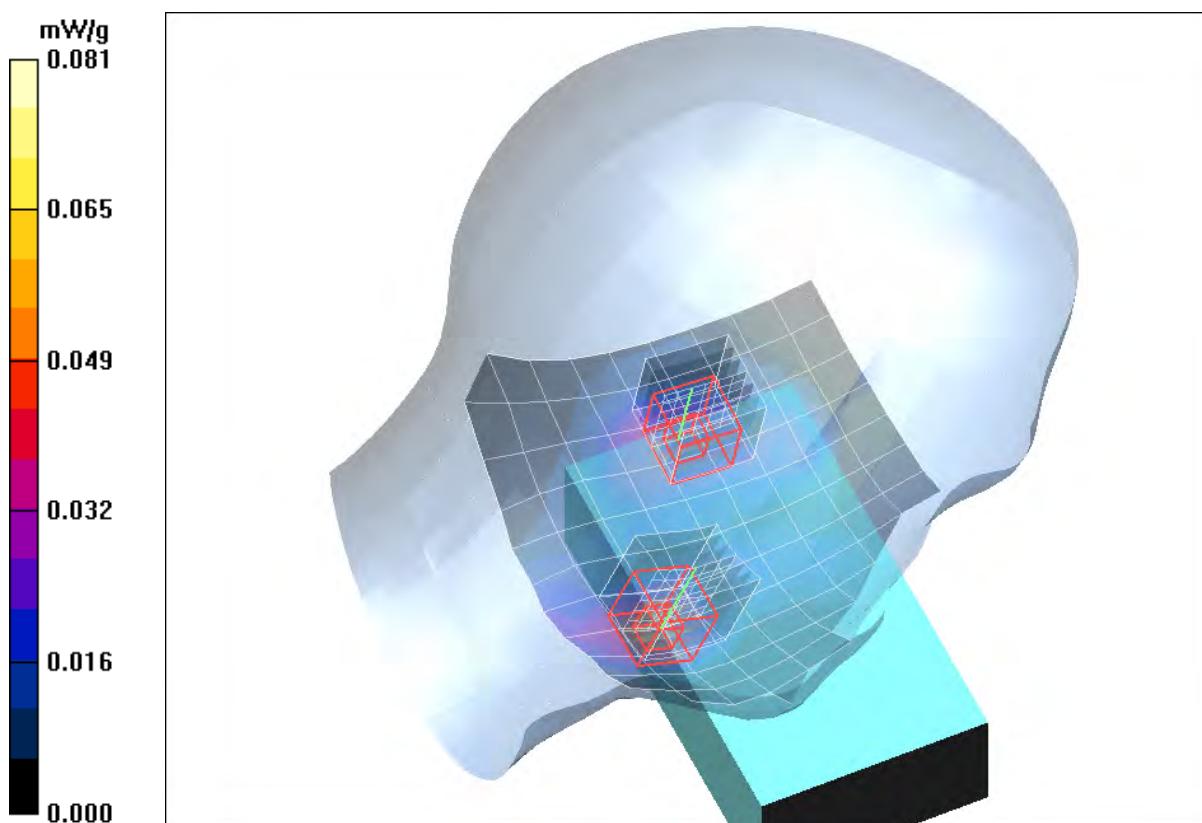

Fig. 43: SAR distribution for IEEE 802.11 g, channel 6, cheek position, left side of head (July 28, 2010; Ambient Temperature: 21.5° C; Liquid Temperature: 21.1° C).

Test Laboratory: Imst GmbH, DASY Yellow (II); File Name: [ELF_ywlm_2_ch6_g.da4](#)

DUT: Datalogic; Type: Elf 701-701; Serial: D10P00071

Program Name: IEEE 802.11 g

Communication System: WLAN 2450; Frequency: 2437 MHz; Duty Cycle: 1:1

Medium parameters used: $f = 2437$ MHz; $\sigma = 1.81$ mho/m; $\epsilon_r = 38.7$; $\rho = 1000$ kg/m³

Phantom section: Left Section

DASY4 Configuration:

- Probe: EX3DV4 - SN3536; ConvF(7.59, 7.59, 7.59); Calibrated: 18.09.2009

- Sensor-Surface: 4mm (Mechanical Surface Detection)

- Electronics: DAE3 Sn335; Calibrated: 10.02.2010

- Phantom: SAM Glycol 1340; Type: QD 000 P40 CB; Serial: TP-1340

- Measurement SW: DASY4, V4.7 Build 80; Postprocessing SW: SEMCAD, V1.8 Build 186

Tilted Left/Area Scan (10x14x1): Measurement grid: dx=15mm, dy=15mm

Maximum value of SAR (measured) = 0.047 mW/g

Tilted Left/Zoom Scan (7x7x7)/Cube 0: Measurement grid: dx=5mm, dy=5mm, dz=5mm

Reference Value = 5.26 V/m; Power Drift = 0.109 dB

Peak SAR (extrapolated) = 0.104 W/kg

SAR(1 g) = 0.055 mW/g; SAR(10 g) = 0.028 mW/g

Maximum value of SAR (measured) = 0.062 mW/g

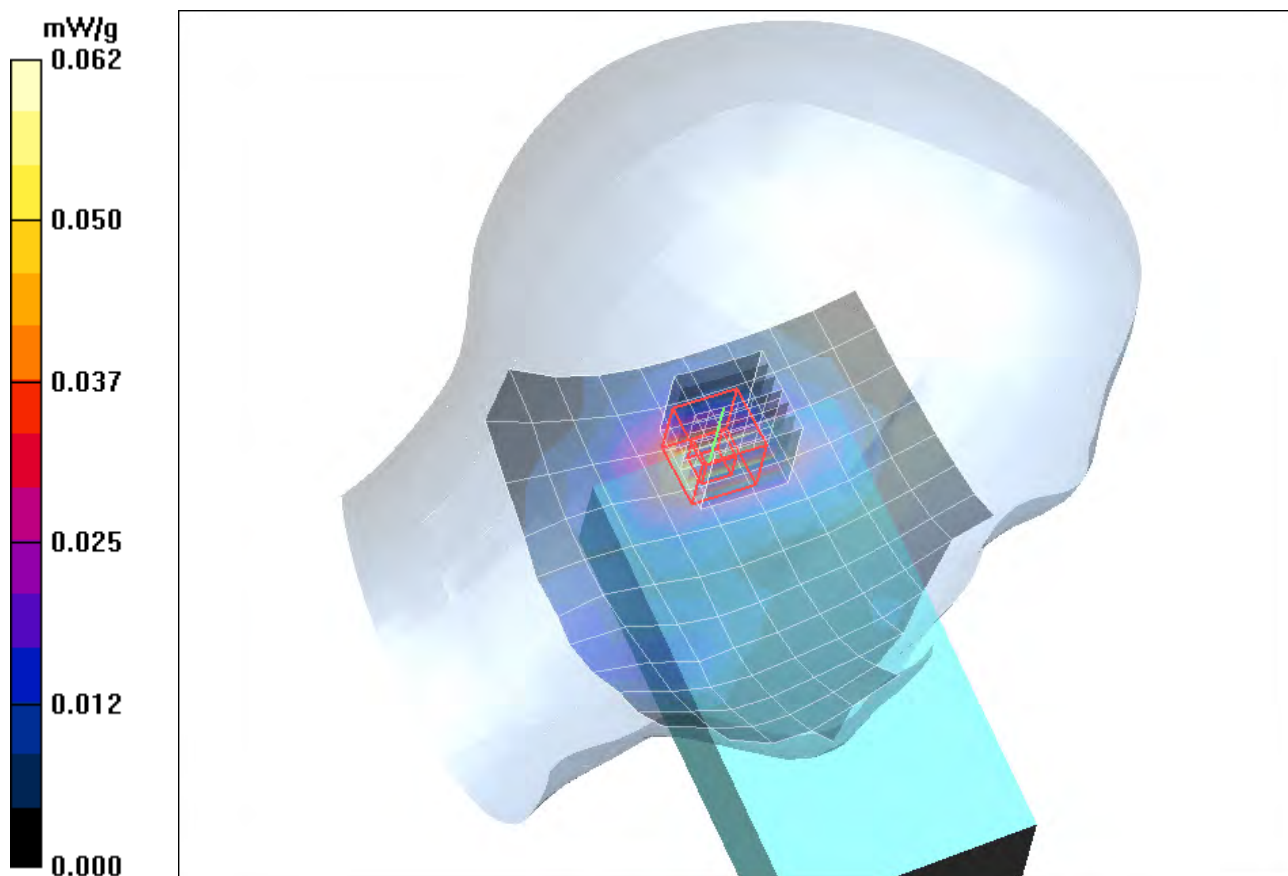

Fig. 44: SAR distribution for IEEE 802.11 g, channel 6, tilted position, left side of head (July 28, 2010; Ambient Temperature: 21.5° C; Liquid Temperature: 21.1° C).

Test Laboratory: Imst GmbH, DASY Yellow (II); File Name: [ELF_ywrm_1_ch6_g.da4](#)

DUT: Datalogic; Type: Elf 701-701; Serial: D10P00071

Program Name: IEEE 802.11 g

Communication System: WLAN 2450; Frequency: 2437 MHz; Duty Cycle: 1:1

Medium parameters used: $f = 2437$ MHz; $\sigma = 1.81$ mho/m; $\epsilon_r = 38.7$; $\rho = 1000$ kg/m³

Phantom section: Right Section

DASY4 Configuration:

- Probe: EX3DV4 - SN3536; ConvF(7.59, 7.59, 7.59); Calibrated: 18.09.2009

- Sensor-Surface: 4mm (Mechanical Surface Detection)

- Electronics: DAE3 Sn335; Calibrated: 10.02.2010

- Phantom: SAM Glycol 1340; Type: QD 000 P40 CB; Serial: TP-1340

- Measurement SW: DASY4, V4.7 Build 80; Postprocessing SW: SEMCAD, V1.8 Build 186

Cheek Right/Area Scan (10x13x1): Measurement grid: dx=15mm, dy=15mm

Maximum value of SAR (measured) = 0.062 mW/g

Cheek Right/Zoom Scan (7x7x7)/Cube 0: Measurement grid: dx=5mm, dy=5mm, dz=5mm

Reference Value = 5.10 V/m; Power Drift = -0.197 dB

Peak SAR (extrapolated) = 0.109 W/kg

SAR(1 g) = 0.059 mW/g; SAR(10 g) = 0.032 mW/g

Maximum value of SAR (measured) = 0.065 mW/g

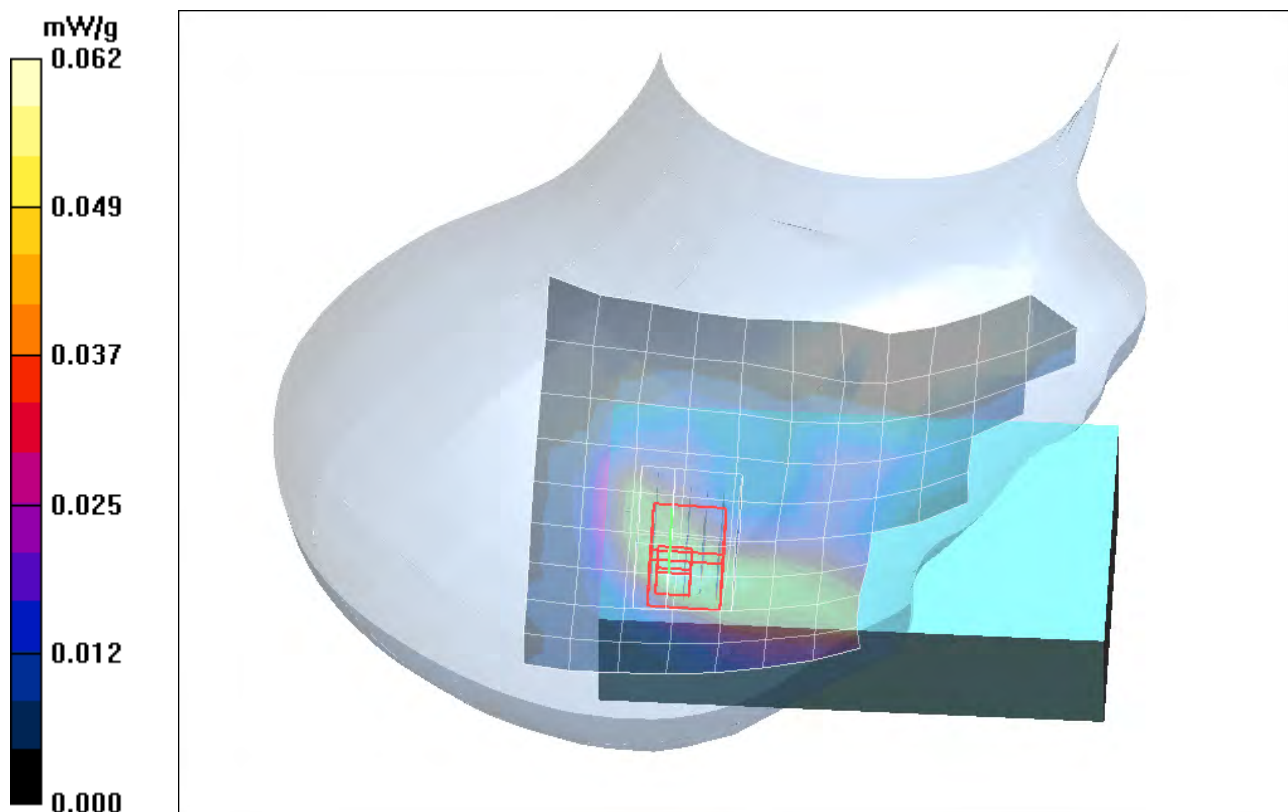

Fig. 45: SAR distribution for IEEE 802.11 g, channel 6, cheek position, right side of head (July 28, 2010; Ambient Temperature: 21.5° C; Liquid Temperature: 21.1° C).

Test Laboratory: Imst GmbH, DASY Yellow (II); File Name: [ELF_ywrm_2_ch6_g.da4](#)

DUT: Datalogic; Type: Elf 701-701; Serial: D10P00071

Program Name: IEEE 802.11 g

Communication System: WLAN 2450; Frequency: 2437 MHz; Duty Cycle: 1:1

Medium parameters used: $f = 2437$ MHz; $\sigma = 1.81$ mho/m; $\epsilon_r = 38.7$; $\rho = 1000$ kg/m³

Phantom section: Right Section

DASY4 Configuration:

- Probe: EX3DV4 - SN3536; ConvF(7.59, 7.59, 7.59); Calibrated: 18.09.2009

- Sensor-Surface: 4mm (Mechanical Surface Detection)

- Electronics: DAE3 Sn335; Calibrated: 10.02.2010

- Phantom: SAM Glycol 1340; Type: QD 000 P40 CB; Serial: TP-1340

- Measurement SW: DASY4, V4.7 Build 80; Postprocessing SW: SEMCAD, V1.8 Build 186

Tilted Right/Area Scan (10x13x1): Measurement grid: dx=15mm, dy=15mm

Maximum value of SAR (measured) = 0.050 mW/g

Tilted Right/Zoom Scan (7x7x7)/Cube 0: Measurement grid: dx=5mm, dy=5mm, dz=5mm

Reference Value = 5.25 V/m; Power Drift = 0.148 dB

Peak SAR (extrapolated) = 0.095 W/kg

SAR(1 g) = 0.049 mW/g; SAR(10 g) = 0.025 mW/g

Maximum value of SAR (measured) = 0.054 mW/g

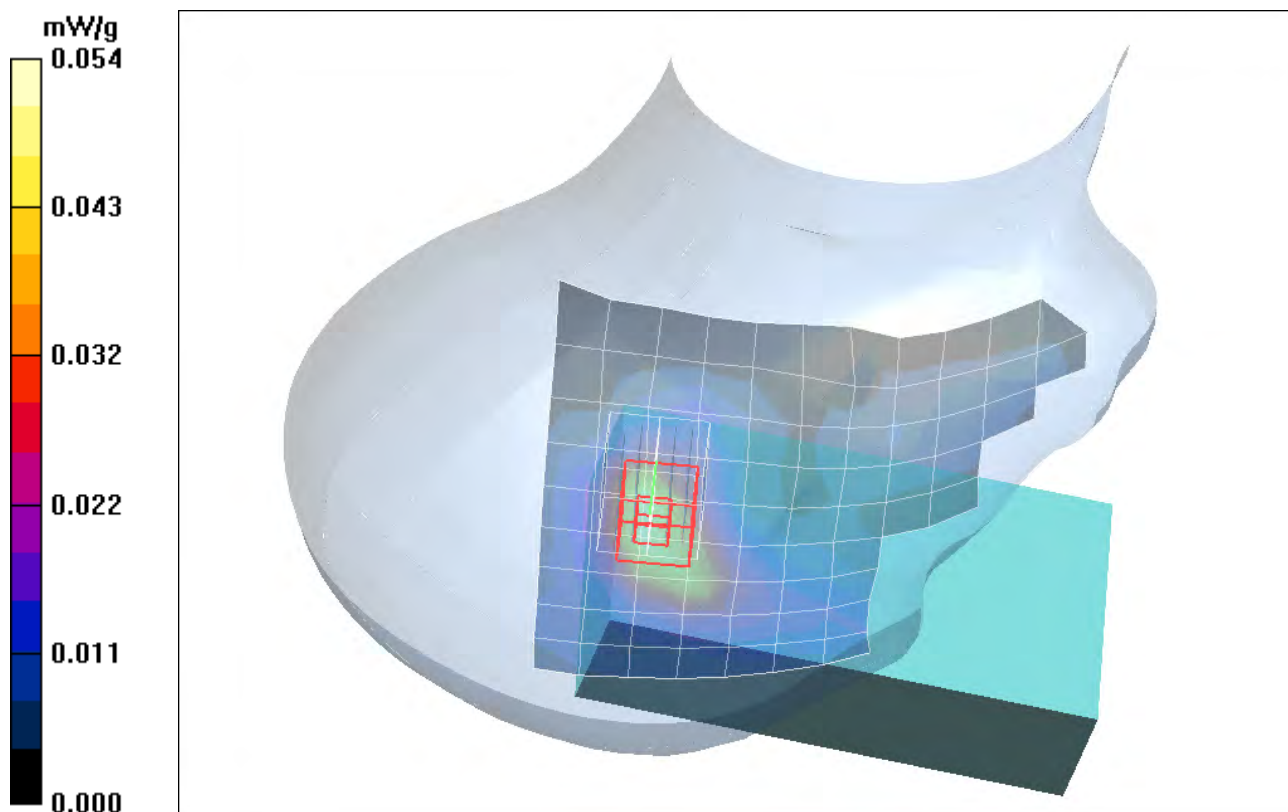

Fig. 46: SAR distribution for IEEE 802.11 g, channel 6, tilted position, right side of head (July 28, 2010; Ambient Temperature: 21.5° C; Liquid Temperature: 21.1° C).

12 SAR Distribution Plots, IEEE 802.11 g Body

Test Laboratory: Imst GmbH, DASY Yellow (II); File Name: [Elf_ywhm_g_CH6_dspl_up.da4](#)

DUT: Datalogic; Type: Elf 701-701; Serial: D10P00071

Program Name: WLAN

Communication System: WLAN 2450; Frequency: 2437 MHz; Duty Cycle: 1:1

Medium parameters used: $f = 2437$ MHz; $\sigma = 1.96$ mho/m; $\epsilon_r = 53.1$; $\rho = 1000$ kg/m³

Phantom section: Flat Section

DASY4 Configuration:

- Probe: EX3DV4 - SN3536; ConvF(7.57, 7.57, 7.57); Calibrated: 18.09.2009

- Sensor-Surface: 4mm (Mechanical Surface Detection)

- Electronics: DAE3 Sn335; Calibrated: 10.02.2010

- Phantom: SAM Glycol 1340; Type: QD 000 P40 CB; Serial: TP-1340

- Measurement SW: DASY4, V4.7 Build 80; Postprocessing SW: SEMCAD, V1.8 Build 186

Body Worn/Area Scan (16x19x1): Measurement grid: dx=10mm, dy=10mm

Maximum value of SAR (measured) = 0.029 mW/g

Body Worn/Zoom Scan (7x7x7)/Cube 0: Measurement grid: dx=5mm, dy=5mm, dz=5mm

Reference Value = 2.06 V/m; Power Drift = 0.117 dB

Peak SAR (extrapolated) = 0.051 W/kg

SAR(1 g) = 0.028 mW/g; SAR(10 g) = 0.016 mW/g

Maximum value of SAR (measured) = 0.030 mW/g

Body Worn/Zoom Scan (7x7x7)/Cube 1: Measurement grid: dx=5mm, dy=5mm, dz=5mm

Reference Value = 2.06 V/m; Power Drift = 0.117 dB

Peak SAR (extrapolated) = 0.047 W/kg

SAR(1 g) = 0.024 mW/g; SAR(10 g) = 0.011 mW/g

Maximum value of SAR (measured) = 0.028 mW/g

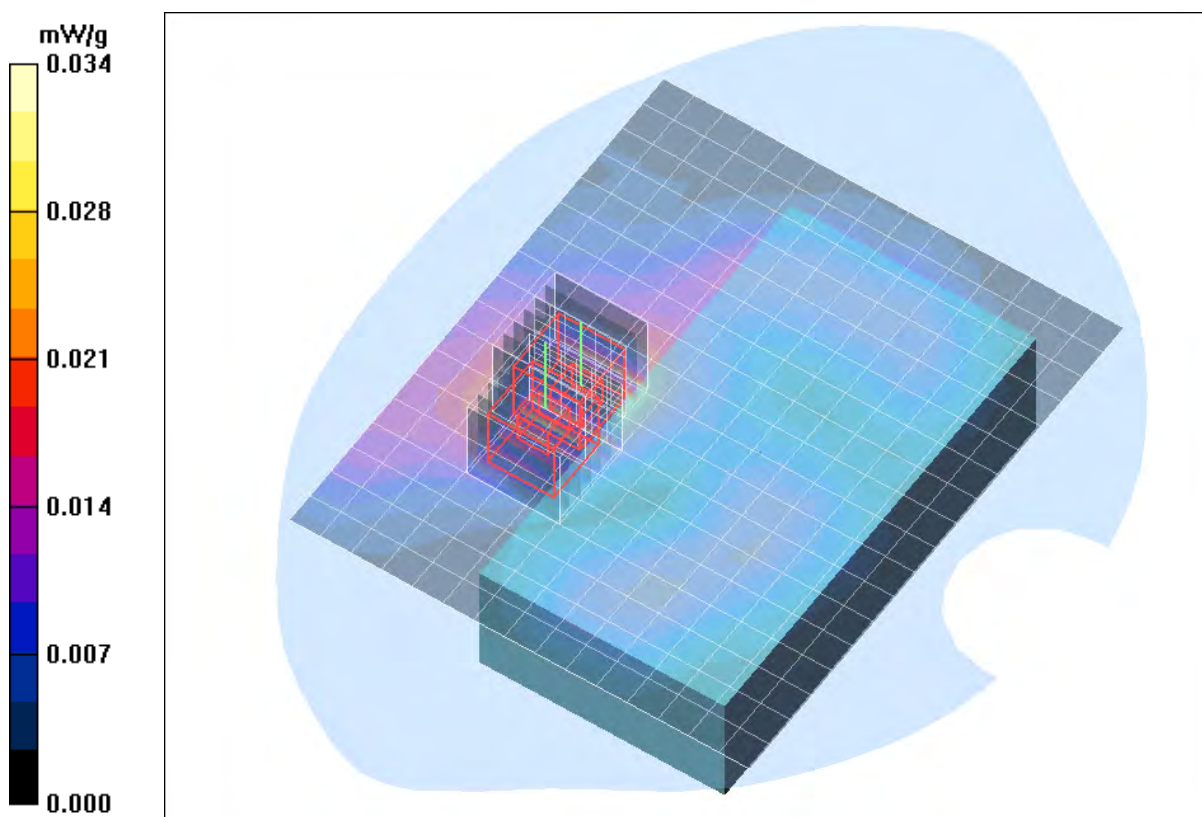

Fig. 47: SAR distribution for IEEE 802.11 g, channel 6, body worn configuration, display towards the phantom, 15 mm distance (May 11, 2010; Ambient Temperature: 21.9° C; Liquid Temperature: 21.5° C).

Test Laboratory: Imst GmbH, DASY Yellow (II); File Name: [Elf_ywhm_g_CH6_dspl_down.da4](#)

DUT: Datalogic; Type: Elf 701-701; Serial: D10P00071

Program Name: WLAN

Communication System: WLAN 2450; Frequency: 2437 MHz; Duty Cycle: 1:1
 Medium parameters used: $f = 2437$ MHz; $\sigma = 1.96$ mho/m; $\epsilon_r = 53.1$; $\rho = 1000$ kg/m³
 Phantom section: Flat Section

DASY4 Configuration:

- Probe: EX3DV4 - SN3536; ConvF(7.57, 7.57, 7.57); Calibrated: 18.09.2009
- Sensor-Surface: 4mm (Mechanical Surface Detection)
- Electronics: DAE3 Sn335; Calibrated: 10.02.2010
- Phantom: SAM Glycol 1340; Type: QD 000 P40 CB; Serial: TP-1340
- Measurement SW: DASY4, V4.7 Build 80; Postprocessing SW: SEMCAD, V1.8 Build 186

Body Worn/Area Scan (16x19x1): Measurement grid: $dx=10$ mm, $dy=10$ mm

Maximum value of SAR (measured) = 0.078 mW/g

Body Worn/Zoom Scan (7x7x7)/Cube 0: Measurement grid: $dx=5$ mm, $dy=5$ mm, $dz=5$ mm

Reference Value = 3.66 V/m; Power Drift = -0.184 dB

Peak SAR (extrapolated) = 0.127 W/kg

SAR(1 g) = 0.072 mW/g; SAR(10 g) = 0.040 mW/g

Maximum value of SAR (measured) = 0.080 mW/g

Body Worn/Zoom Scan (7x7x7)/Cube 1: Measurement grid: $dx=5$ mm, $dy=5$ mm, $dz=5$ mm

Reference Value = 3.66 V/m; Power Drift = -0.184 dB

Peak SAR (extrapolated) = 0.082 W/kg

SAR(1 g) = 0.047 mW/g; SAR(10 g) = 0.026 mW/g

Maximum value of SAR (measured) = 0.051 mW/g

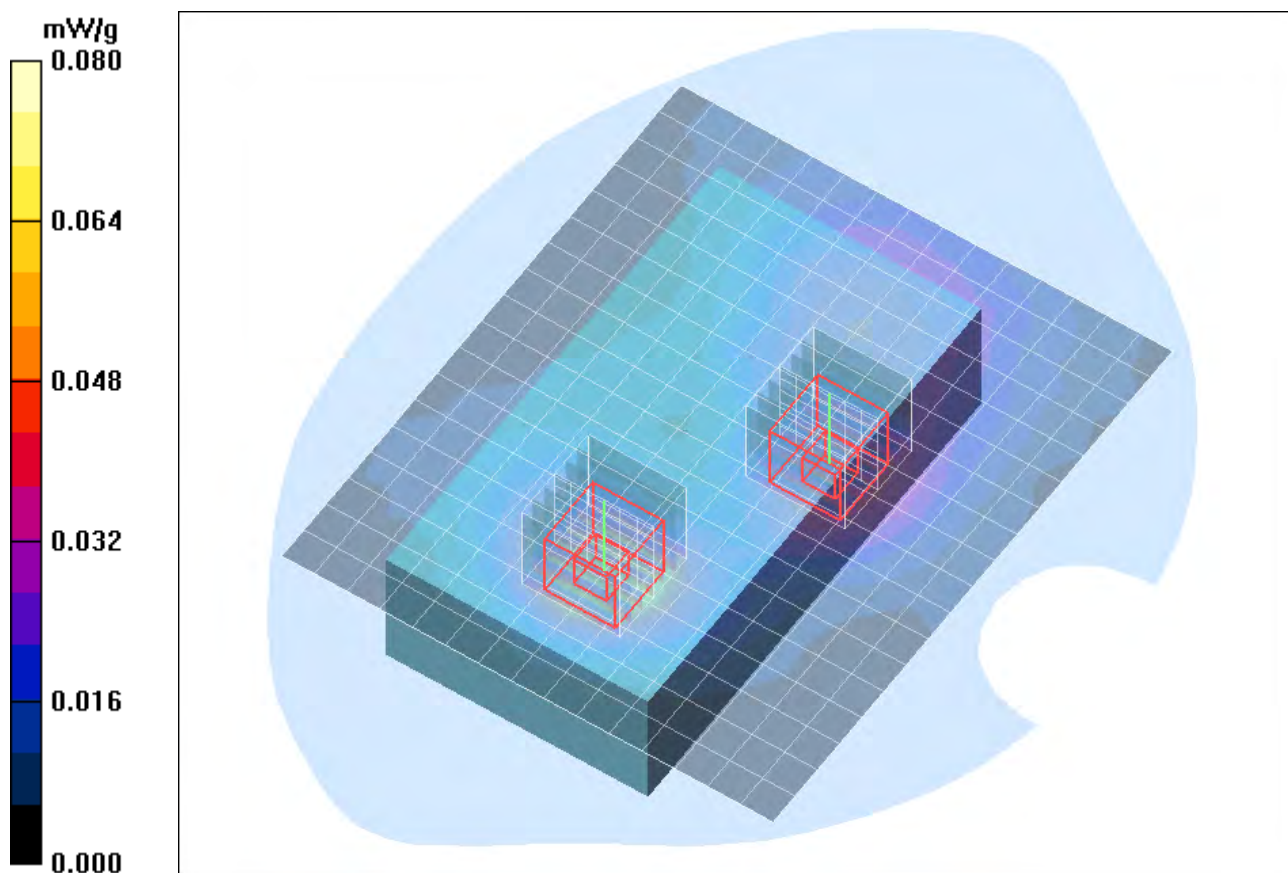

Fig. 48: SAR distribution for IEEE 802.11 g, channel 6, body worn configuration, display towards the ground, 15 mm distance (May 11, 2010; Ambient Temperature: 21.9° C; Liquid Temperature: 21.5° C).

13 SAR Distribution Plots, IEEE 802.11 a Head (5200 MHz Range)

Test Laboratory: IMST GmbH, DASY Blue (I); File Name: [Elf bwlm 1 CH36.da4](#)

DUT: Datalogic; Type: Elf 701-701; Serial: D10P00071

Program Name: Cheek Left

Communication System: 5 GHz ; Frequency: 5180 MHz; Duty Cycle: 1:1

Medium parameters used: $f = 5180$ MHz; $\sigma = 4.77$ mho/m; $\epsilon_r = 37.2$; $\rho = 1000$ kg/m³

Phantom section: Left Section

DASY4 Configuration:

- Probe: EX3DV4 - SN3536; ConvF(5.24, 5.24, 5.24); Calibrated: 18.09.2009

- Sensor-Surface: 4mm (Mechanical Surface Detection)

- Electronics: DAE3 Sn335; Calibrated: 10.02.2010

- Phantom: SAM Glycol 1176; Type: Speag; Serial: 1176

- Measurement SW: DASY4, V4.7 Build 80; Postprocessing SW: SEMCAD, V1.8 Build 186

Cheek Left/Area Scan (9x14x1): Measurement grid: dx=15mm, dy=15mm

Maximum value of SAR (measured) = 0.147 mW/g

Cheek Left/Zoom Scan (7x7x7)/Cube 0: Measurement grid: dx=5mm, dy=5mm, dz=5mm

Reference Value = 6.06 V/m; Power Drift = 0.032 dB

Peak SAR (extrapolated) = 0.456 W/kg

SAR(1 g) = 0.170 mW/g; SAR(10 g) = 0.059 mW/g

Maximum value of SAR (measured) = 0.197 mW/g

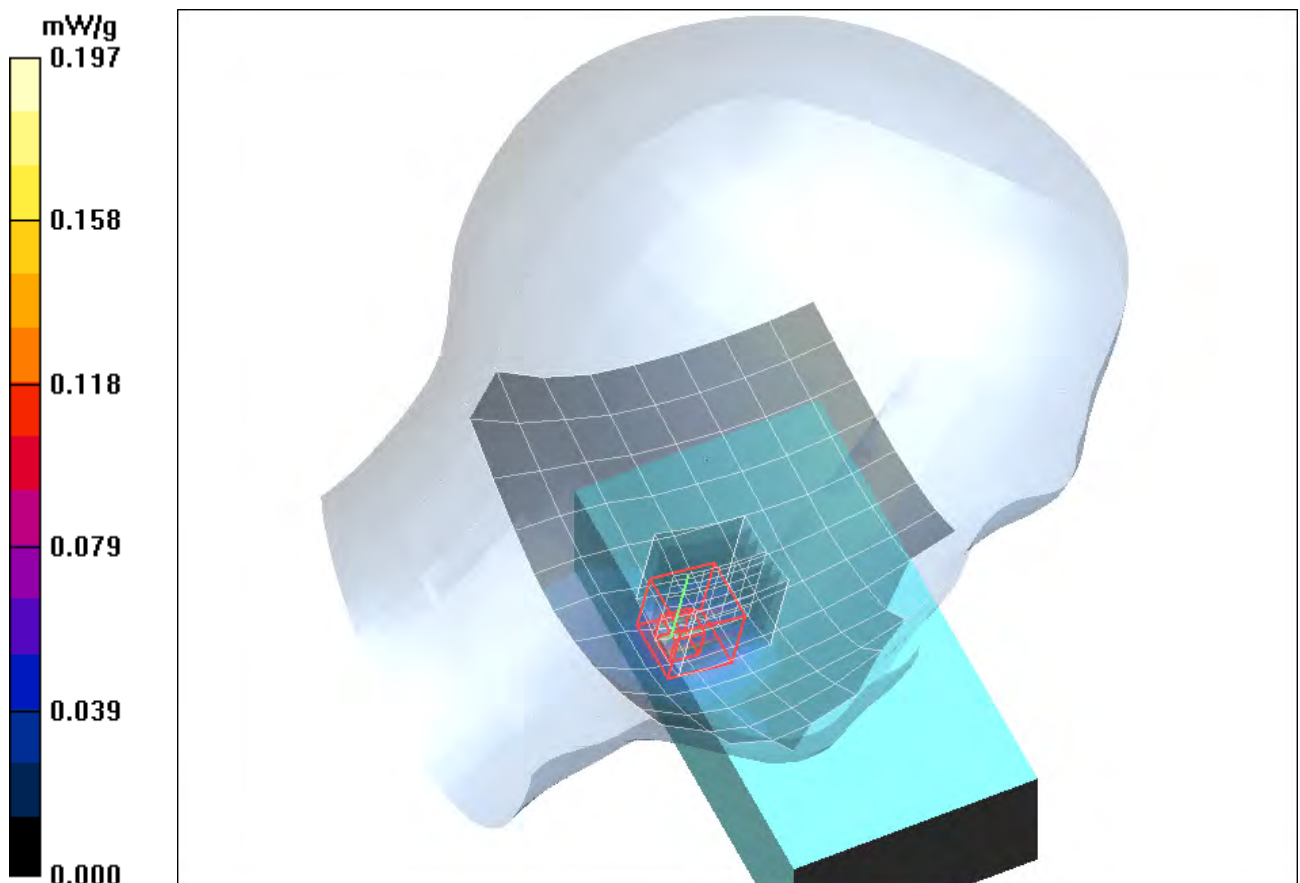

Fig. 49: SAR distribution for IEEE 802.11 a, channel 36, cheek position, left side of head (May 20, 2010; Ambient Temperature: 21.7° C; Liquid Temperature: 21.1° C).

Test Laboratory: IMST GmbH, DASY Blue (I); File Name: [Elf_bwlm_1_CH48.da4](#)

DUT: Datalogic; Type: Elf 701-701; Serial: D10P00071

Program Name: Cheek Left

Communication System: 5 GHz ; Frequency: 5240 MHz;Duty Cycle: 1:1

Medium parameters used: $f = 5240$ MHz; $\sigma = 4.78$ mho/m; $\epsilon_r = 37$; $\rho = 1000$ kg/m³

Phantom section: Left Section

DASY4 Configuration:

- Probe: EX3DV4 - SN3536; ConvF(5.24, 5.24, 5.24); Calibrated: 18.09.2009
- Sensor-Surface: 4mm (Mechanical Surface Detection)
- Electronics: DAE3 Sn335; Calibrated: 10.02.2010
- Phantom: SAM Glycol 1176; Type: Speag; Serial: 1176
- Measurement SW: DASY4, V4.7 Build 80; Postprocessing SW: SEMCAD, V1.8 Build 186

Cheek Left/Area Scan (9x14x1): Measurement grid: dx=15mm, dy=15mm

Maximum value of SAR (measured) = 0.139 mW/g

Cheek Left/Zoom Scan (7x7x7)/Cube 0: Measurement grid: dx=5mm, dy=5mm, dz=5mm

Reference Value = 5.85 V/m; Power Drift = 0.126 dB

Peak SAR (extrapolated) = 0.410 W/kg

SAR(1 g) = 0.160 mW/g; SAR(10 g) = 0.055 mW/g

Maximum value of SAR (measured) = 0.190 mW/g

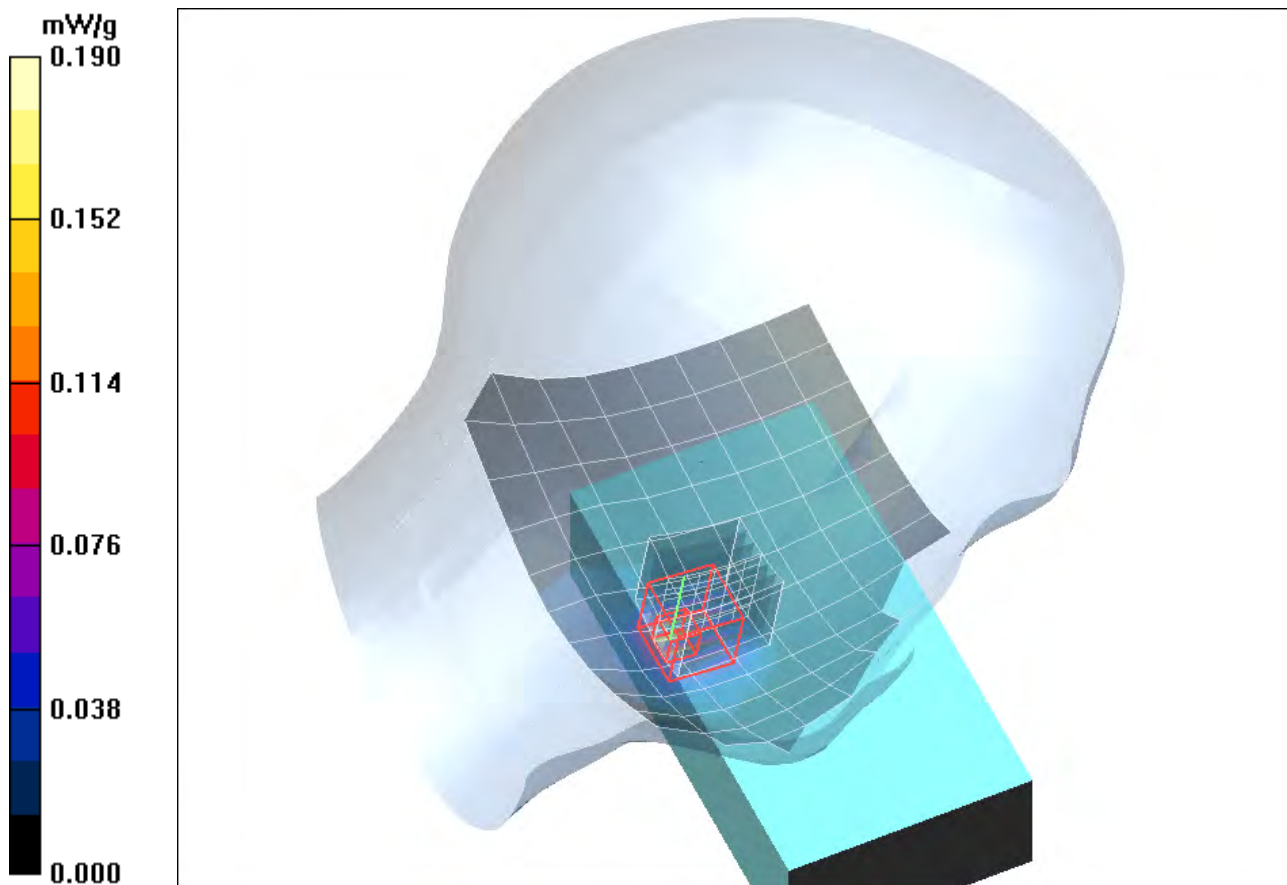

Fig. 50: SAR distribution for IEEE 802.11 a, channel 48, cheek position, left side of head (May 20, 2010; Ambient Temperature: 21.7° C; Liquid Temperature: 21.1° C).

Test Laboratory: IMST GmbH, DASY Blue (I); File Name: [Elf_bwlm_1_CH52.da4](#)

DUT: Datalogic; Type: Elf 701-701; Serial: D10P00071

Program Name: Cheek Left

Communication System: 5 GHz ; Frequency: 5260 MHz;Duty Cycle: 1:1

Medium parameters used: $f = 5260$ MHz; $\sigma = 4.81$ mho/m; $\epsilon_r = 36.9$; $\rho = 1000$ kg/m³

Phantom section: Left Section

DASY4 Configuration:

- Probe: EX3DV4 - SN3536; ConvF(4.96, 4.96, 4.96); Calibrated: 18.09.2009
- Sensor-Surface: 4mm (Mechanical Surface Detection)
- Electronics: DAE3 Sn335; Calibrated: 10.02.2010
- Phantom: SAM Glycol 1176; Type: Speag; Serial: 1176
- Measurement SW: DASY4, V4.7 Build 80; Postprocessing SW: SEMCAD, V1.8 Build 186

Cheek Left/Area Scan (10x14x1): Measurement grid: dx=15mm, dy=15mm

Maximum value of SAR (measured) = 0.138 mW/g

Cheek Left/Zoom Scan (7x7x7)/Cube 0: Measurement grid: dx=5mm, dy=5mm, dz=5mm

Reference Value = 5.65 V/m; Power Drift = 0.042 dB

Peak SAR (extrapolated) = 0.482 W/kg

SAR(1 g) = 0.161 mW/g; SAR(10 g) = 0.058 mW/g

Maximum value of SAR (measured) = 0.181 mW/g

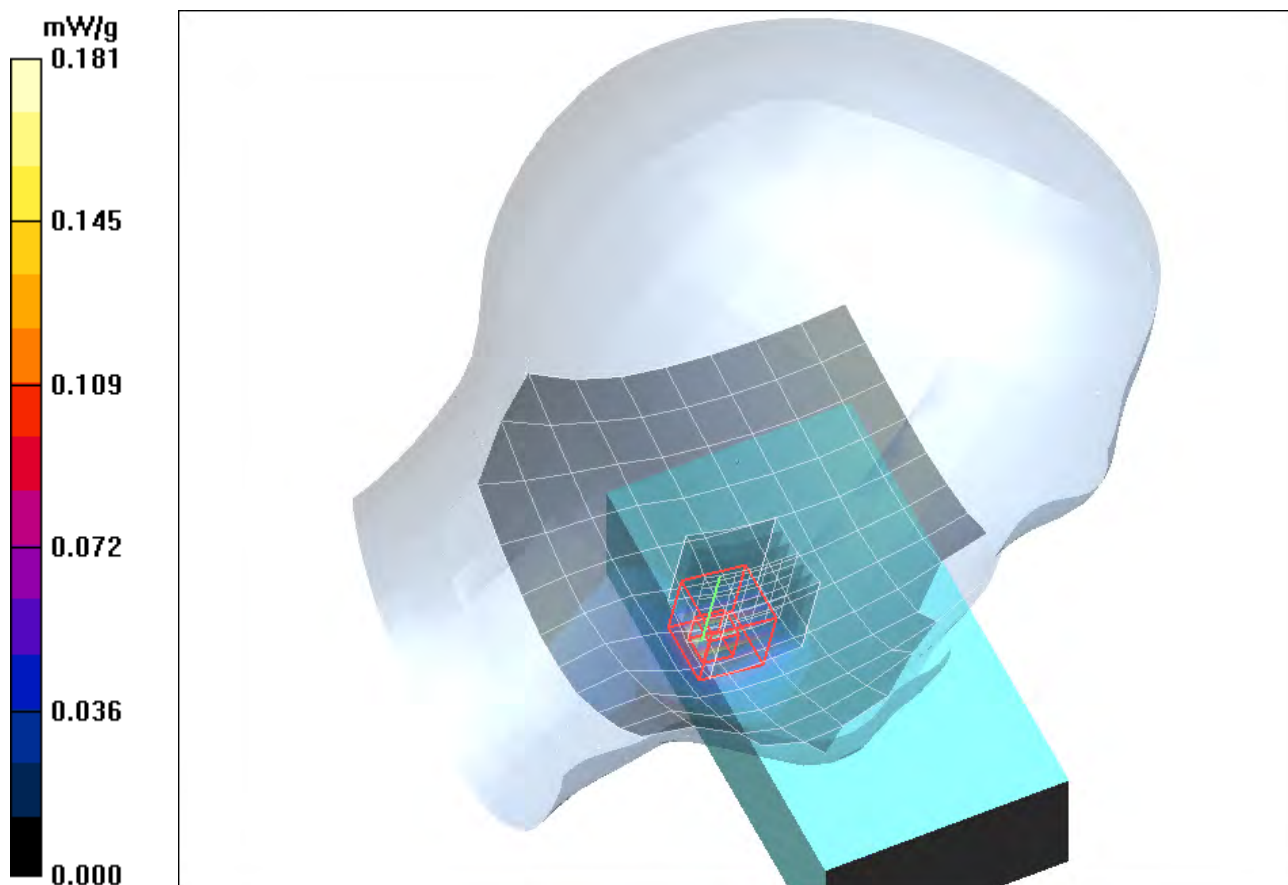

Fig. 51: SAR distribution for IEEE 802.11 a, channel 52, cheek position, left side of head (May 20, 2010; Ambient Temperature: 21.7° C; Liquid Temperature: 21.1° C).

Test Laboratory: IMST GmbH, DASY Blue (I); File Name: [Elf_bwlm_1_CH64.da4](#)

DUT: Datalogic; Type: Elf 701-701; Serial: D10P00071

Program Name: Cheek Left

Communication System: 5 GHz ; Frequency: 5320 MHz;Duty Cycle: 1:1

Medium parameters used: $f = 5320$ MHz; $\sigma = 4.88$ mho/m; $\epsilon_r = 36.9$; $\rho = 1000$ kg/m³

Phantom section: Left Section

DASY4 Configuration:

- Probe: EX3DV4 - SN3536; ConvF(4.96, 4.96, 4.96); Calibrated: 18.09.2009

- Sensor-Surface: 4mm (Mechanical Surface Detection)

- Electronics: DAE3 Sn335; Calibrated: 10.02.2010

- Phantom: SAM Glycol 1176; Type: Speag; Serial: 1176

- Measurement SW: DASY4, V4.7 Build 80; Postprocessing SW: SEMCAD, V1.8 Build 186

Cheek Left/Area Scan (9x14x1): Measurement grid: dx=15mm, dy=15mm

Maximum value of SAR (measured) = 0.124 mW/g

Cheek Left/Zoom Scan (7x7x7)/Cube 0: Measurement grid: dx=5mm, dy=5mm, dz=5mm

Reference Value = 5.45 V/m; Power Drift = 0.096 dB

Peak SAR (extrapolated) = 0.442 W/kg

SAR(1 g) = 0.144 mW/g; SAR(10 g) = 0.050 mW/g

Maximum value of SAR (measured) = 0.164 mW/g

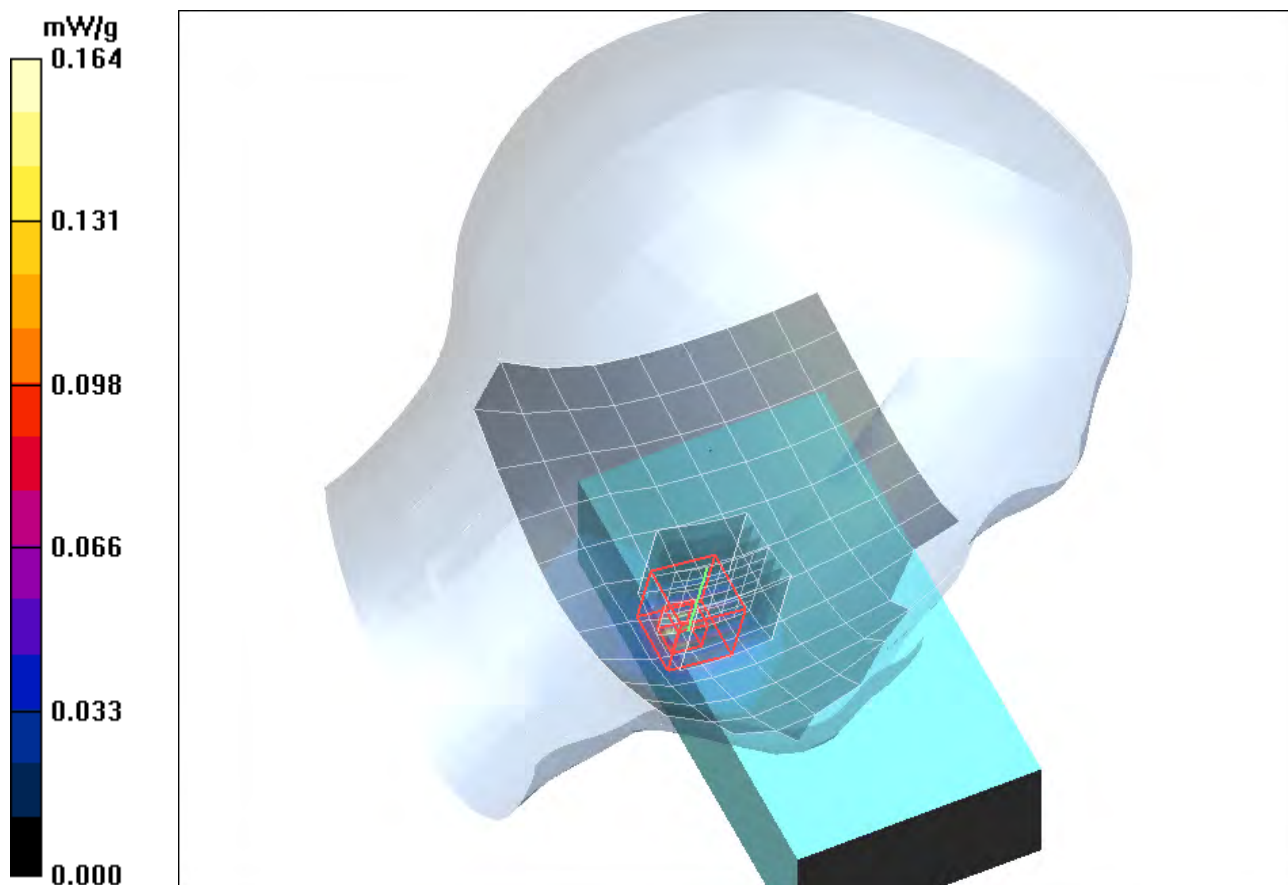

Fig. 52: SAR distribution for IEEE 802.11 a, channel 64, cheek position, left side of head (May 20, 2010; Ambient Temperature: 21.7° C; Liquid Temperature: 21.1° C).

Test Laboratory: IMST GmbH, DASY Blue (I); File Name: [Elf_bwlm_2_CH36.da4](#)

DUT: Datalogic; Type: Elf 701-701; Serial: D10P00071

Program Name: Tilted Left

Communication System: 5 GHz ; Frequency: 5180 MHz; Duty Cycle: 1:1

Medium parameters used: $f = 5180$ MHz; $\sigma = 4.77$ mho/m; $\epsilon_r = 37.2$; $\rho = 1000$ kg/m³

Phantom section: Left Section

DASY4 Configuration:

- Probe: EX3DV4 - SN3536; ConvF(5.24, 5.24, 5.24); Calibrated: 18.09.2009
- Sensor-Surface: 4mm (Mechanical Surface Detection)
- Electronics: DAE3 Sn335; Calibrated: 10.02.2010
- Phantom: SAM Glycol 1176; Type: Speag; Serial: 1176
- Measurement SW: DASY4, V4.7 Build 80; Postprocessing SW: SEMCAD, V1.8 Build 186

Tilted Left/Area Scan (9x14x1): Measurement grid: dx=15mm, dy=15mm

Maximum value of SAR (measured) = 0.051 mW/g

Tilted Left/Zoom Scan (7x7x7)/Cube 0: Measurement grid: dx=5mm, dy=5mm, dz=5mm

Reference Value = 3.30 V/m; Power Drift = 0.016 dB

Peak SAR (extrapolated) = 0.309 W/kg

SAR(1 g) = 0.064 mW/g; SAR(10 g) = 0.023 mW/g

Maximum value of SAR (measured) = 0.052 mW/g

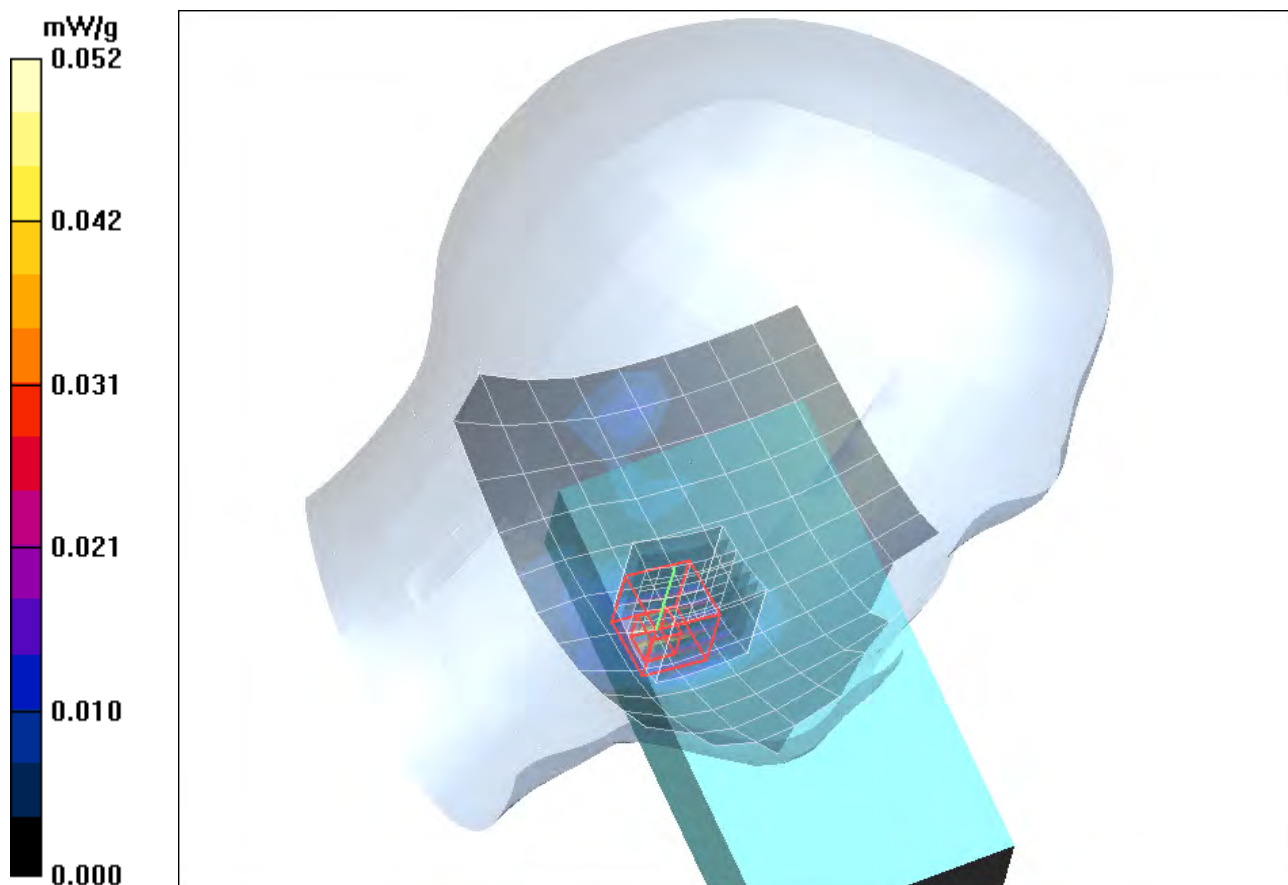

Fig. 53: SAR distribution for IEEE 802.11 g, channel 36, tilted position, left side of head (May 20, 2010; Ambient Temperature: 21.7° C; Liquid Temperature: 21.1° C).

Test Laboratory: IMST GmbH, DASY Blue (I); File Name: [Elf_bwrn_1_CH48.da4](#)

DUT: Datalogic; Type: Elf 701-701; Serial: D10P00071

Program Name: Cheek Right

Communication System: 5 GHz ; Frequency: 5240 MHz;Duty Cycle: 1:1

Medium parameters used: $f = 5240$ MHz; $\sigma = 4.78$ mho/m; $\epsilon_r = 37$; $\rho = 1000$ kg/m³

Phantom section: Right Section

DASY4 Configuration:

- Probe: EX3DV4 - SN3536; ConvF(5.24, 5.24, 5.24); Calibrated: 18.09.2009

- Sensor-Surface: 4mm (Mechanical Surface Detection)

- Electronics: DAE3 Sn335; Calibrated: 10.02.2010

- Phantom: SAM Glycol 1176; Type: Speag; Serial: 1176

- Measurement SW: DASY4, V4.7 Build 80; Postprocessing SW: SEMCAD, V1.8 Build 186

Cheek Right/Area Scan (10x14x1): Measurement grid: $dx=15$ mm, $dy=15$ mm

Maximum value of SAR (measured) = 0.058 mW/g

Cheek Right/Zoom Scan (7x7x7)/Cube 0: Measurement grid: $dx=5$ mm, $dy=5$ mm, $dz=5$ mm

Reference Value = 3.68 V/m; Power Drift = 0.065 dB

Peak SAR (extrapolated) = 0.318 W/kg

SAR(1 g) = 0.074 mW/g; SAR(10 g) = 0.029 mW/g

Maximum value of SAR (measured) = 0.073 mW/g

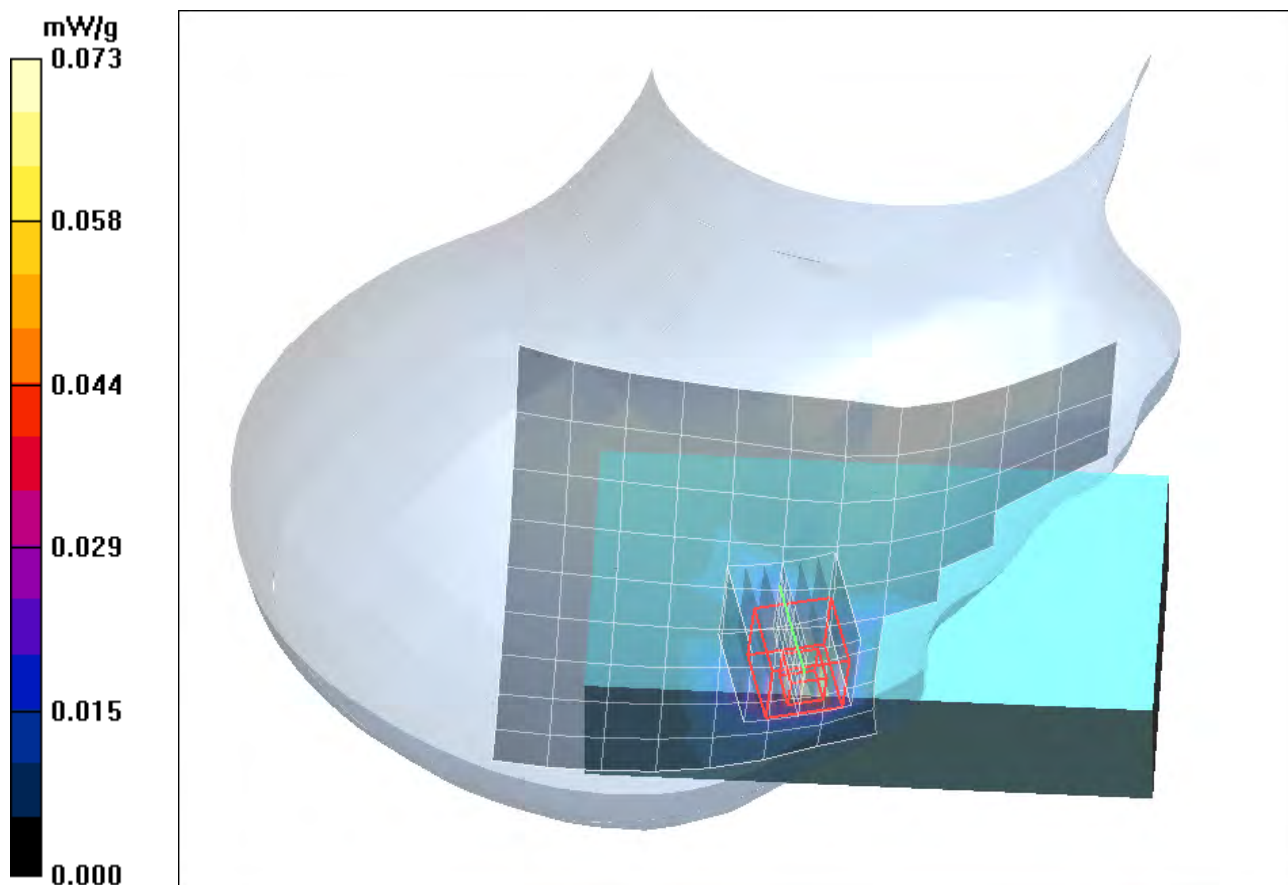

Fig. 54: SAR distribution for IEEE 802.11 a, channel 36, cheek position, right side of head (May 20, 2010; Ambient Temperature: 21.7° C; Liquid Temperature: 21.1° C).

Test Laboratory: IMST GmbH, DASY Blue (I); File Name: [Elf_bwrn_1_CH48.da4](#)

DUT: Datalogic; Type: Elf 701-701; Serial: D10P00071
 Program Name: Cheek Right

Communication System: 5 GHz ; Frequency: 5240 MHz;Duty Cycle: 1:1
 Medium parameters used: $f = 5240$ MHz; $\sigma = 4.78$ mho/m; $\epsilon_r = 37$; $\rho = 1000$ kg/m³
 Phantom section: Right Section

DASY4 Configuration:

- Probe: EX3DV4 - SN3536; ConvF(5.24, 5.24, 5.24); Calibrated: 18.09.2009
- Sensor-Surface: 4mm (Mechanical Surface Detection)
- Electronics: DAE3 Sn335; Calibrated: 10.02.2010
- Phantom: SAM Glycol 1176; Type: Speag; Serial: 1176
- Measurement SW: DASY4, V4.7 Build 80; Postprocessing SW: SEMCAD, V1.8 Build 186

Cheek Right/Area Scan (10x14x1): Measurement grid: dx=15mm, dy=15mm

Maximum value of SAR (measured) = 0.058 mW/g

Cheek Right/Zoom Scan (7x7x7)/Cube 0: Measurement grid: dx=5mm, dy=5mm, dz=5mm

Reference Value = 3.68 V/m; Power Drift = 0.065 dB

Peak SAR (extrapolated) = 0.318 W/kg

SAR(1 g) = 0.074 mW/g; SAR(10 g) = 0.029 mW/g

Maximum value of SAR (measured) = 0.073 mW/g

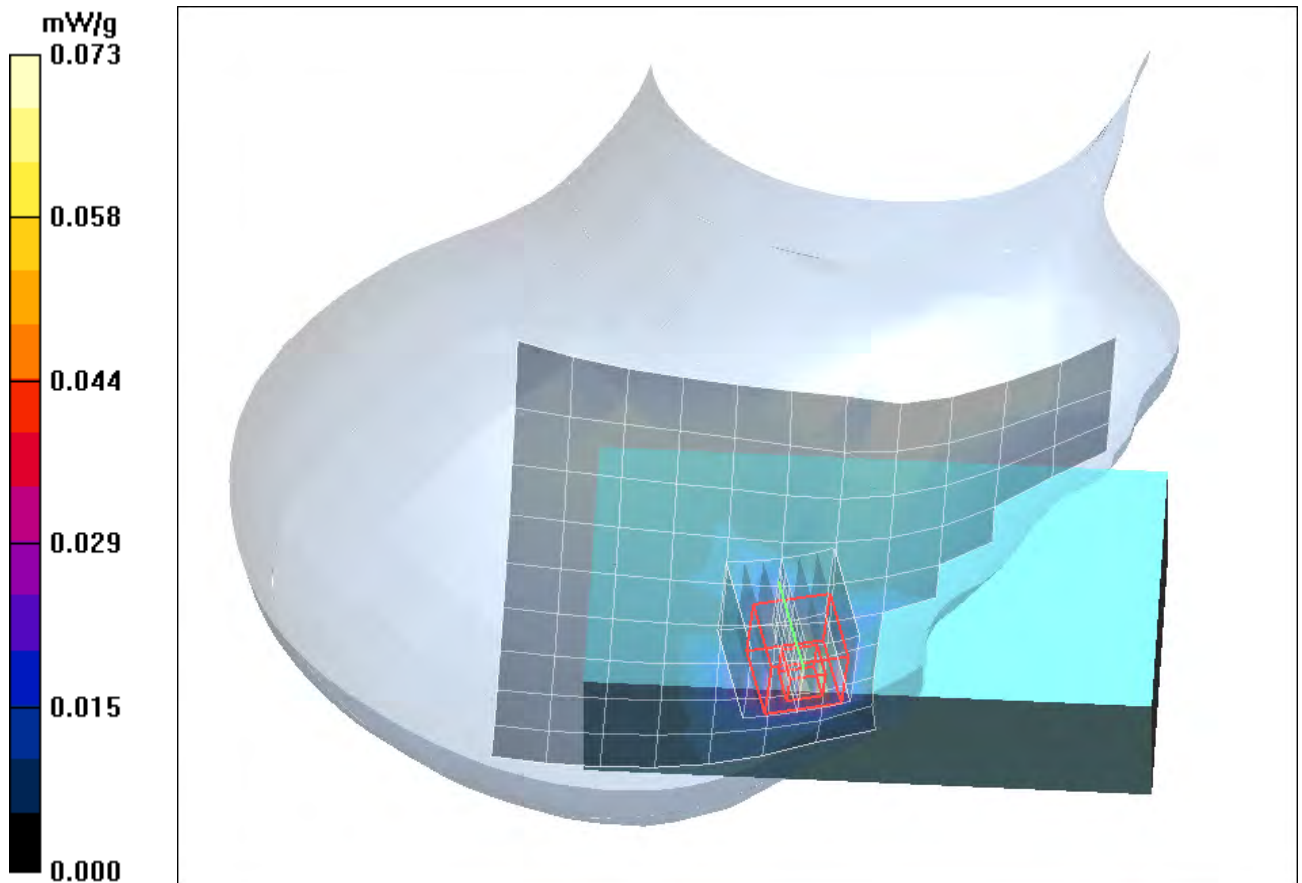

Fig. 55: SAR distribution for IEEE 802.11 a, channel 48, cheek position, right side of head (May 20, 2010; Ambient Temperature: 21.7° C; Liquid Temperature: 21.1° C).

Test Laboratory: IMST GmbH, DASY Blue (I); File Name: [Elf_bwrm_1_CH52.da4](#)

DUT: Datalogic; Type: Elf 701-701; Serial: D10P00071

Program Name: Cheek Right

Communication System: 5 GHz ; Frequency: 5260 MHz; Duty Cycle: 1:1

Medium parameters used: $f = 5260$ MHz; $\sigma = 4.81$ mho/m; $\epsilon_r = 36.9$; $\rho = 1000$ kg/m³

Phantom section: Right Section

DASY4 Configuration:

- Probe: EX3DV4 - SN3536; ConvF(4.96, 4.96, 4.96); Calibrated: 18.09.2009
- Sensor-Surface: 4mm (Mechanical Surface Detection)
- Electronics: DAE3 Sn335; Calibrated: 10.02.2010
- Phantom: SAM Glycol 1176; Type: Speag; Serial: 1176
- Measurement SW: DASY4, V4.7 Build 80; Postprocessing SW: SEMCAD, V1.8 Build 186

Cheek Right/Area Scan (10x14x1): Measurement grid: dx=15mm, dy=15mm

Maximum value of SAR (measured) = 0.061 mW/g

Cheek Right/Zoom Scan (7x7x7)/Cube 0: Measurement grid: dx=5mm, dy=5mm, dz=5mm

Reference Value = 3.59 V/m; Power Drift = -0.070 dB

Peak SAR (extrapolated) = 0.278 W/kg

SAR(1 g) = 0.070 mW/g; SAR(10 g) = 0.027 mW/g

Maximum value of SAR (measured) = 0.071 mW/g

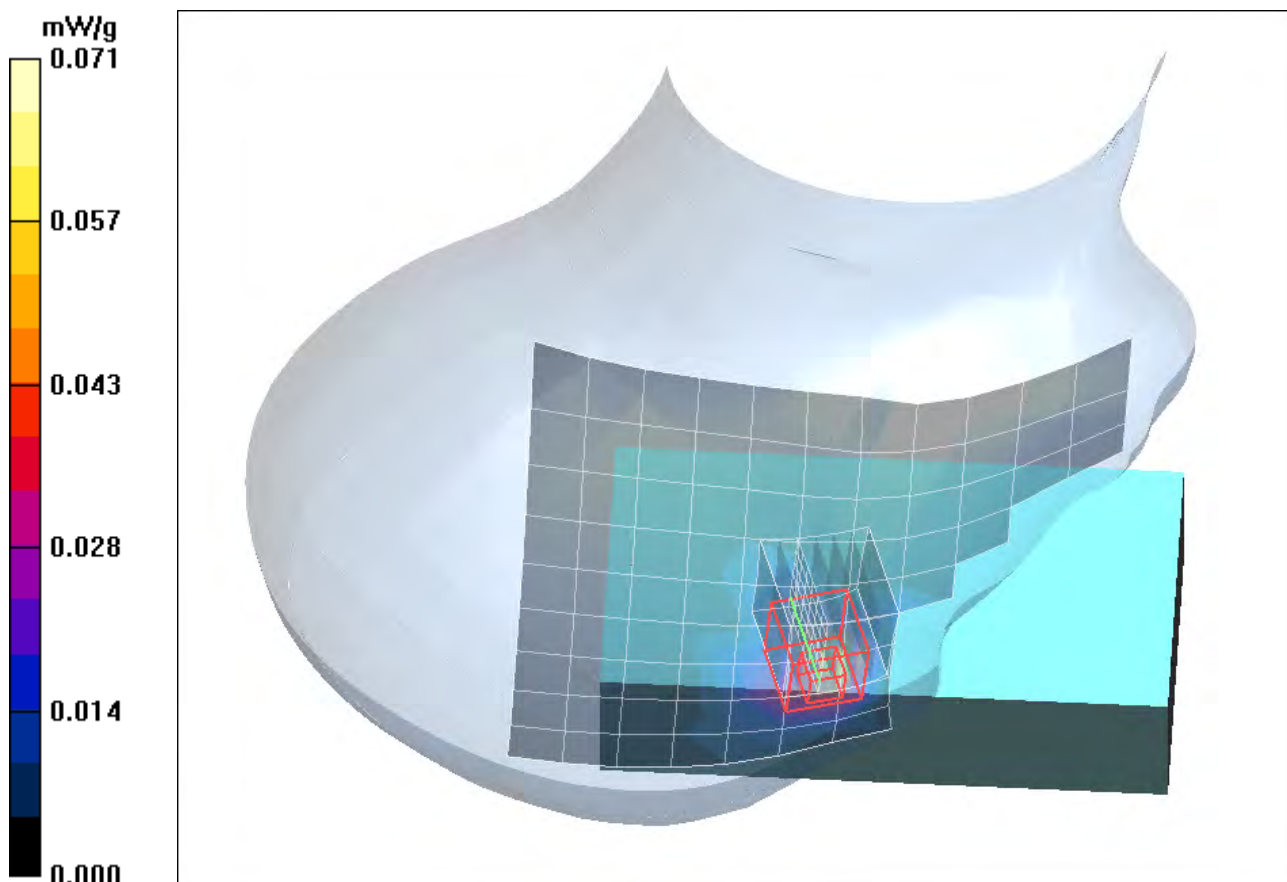

Fig. 56: SAR distribution for IEEE 802.11 a, channel 52, cheek position, right side of head (May 20, 2010; Ambient Temperature: 21.7° C; Liquid Temperature: 21.1° C).

Test Laboratory: IMST GmbH, DASY Blue (I); File Name: [Elf_bwrm_1_CH64.da4](#)

DUT: Datalogic; Type: Elf 701-701; Serial: D10P00071

Program Name: Cheek Right

Communication System: 5 GHz ; Frequency: 5320 MHz; Duty Cycle: 1:1

Medium parameters used: $f = 5320$ MHz; $\sigma = 4.88$ mho/m; $\epsilon_r = 36.9$; $\rho = 1000$ kg/m³

Phantom section: Right Section

DASY4 Configuration:

- Probe: EX3DV4 - SN3536; ConvF(4.96, 4.96, 4.96); Calibrated: 18.09.2009
- Sensor-Surface: 4mm (Mechanical Surface Detection)
- Electronics: DAE3 Sn335; Calibrated: 10.02.2010
- Phantom: SAM Glycol 1176; Type: Speag; Serial: 1176
- Measurement SW: DASY4, V4.7 Build 80; Postprocessing SW: SEMCAD, V1.8 Build 186

Cheek Right/Area Scan (10x14x1): Measurement grid: dx=15mm, dy=15mm

Maximum value of SAR (measured) = 0.062 mW/g

Cheek Right/Zoom Scan (7x7x7)/Cube 0: Measurement grid: dx=5mm, dy=5mm, dz=5mm

Reference Value = 3.54 V/m; Power Drift = -0.026 dB

Peak SAR (extrapolated) = 0.364 W/kg

SAR(1 g) = 0.077 mW/g; SAR(10 g) = 0.028 mW/g

Maximum value of SAR (measured) = 0.068 mW/g

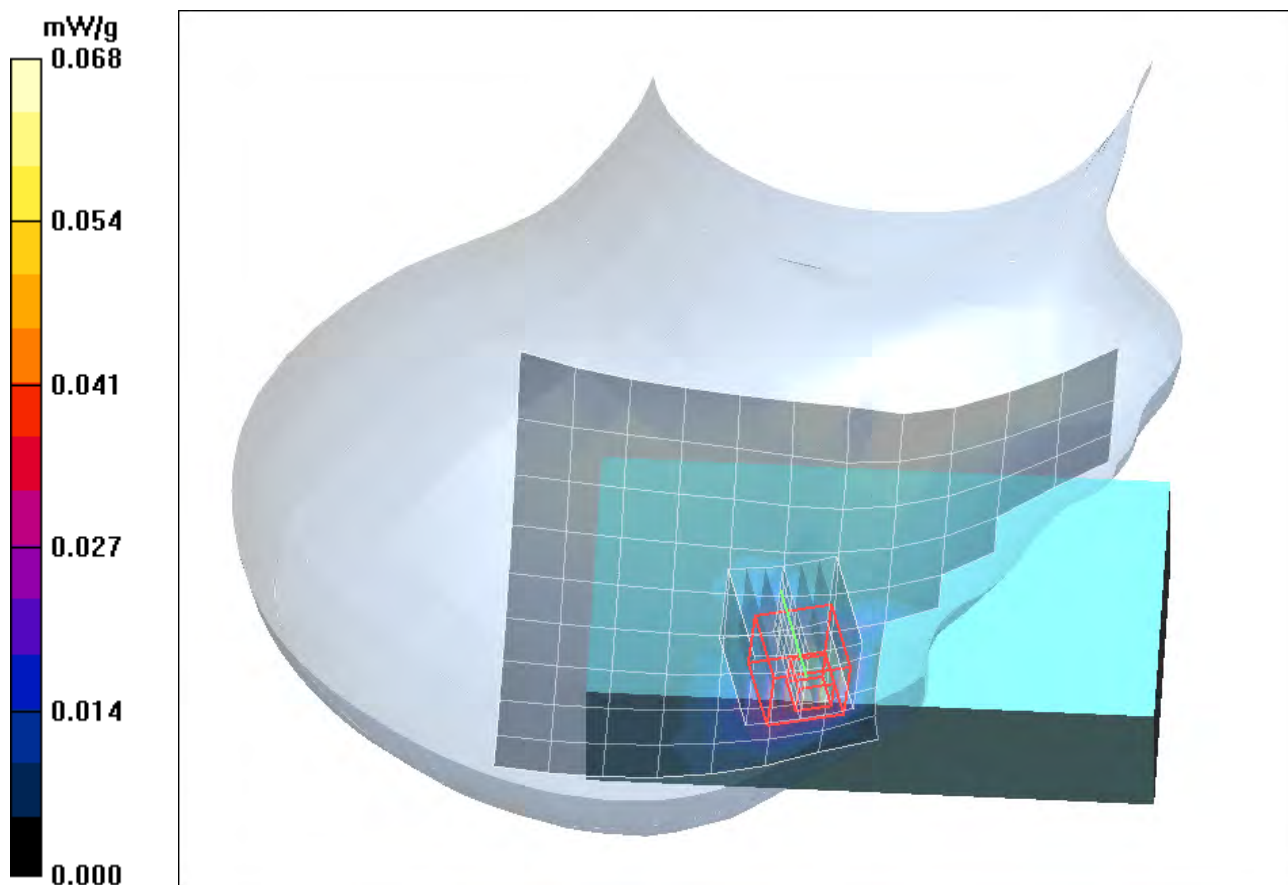

Fig. 57: SAR distribution for IEEE 802.11 a, channel 64, cheek position, right side of head (May 20, 2010; Ambient Temperature: 21.7° C; Liquid Temperature: 21.1° C).

Test Laboratory: IMST GmbH, DASY Blue (I); **File Name:** [Elf_bwrn 2_CH36.da4](#)

DUT: Datalogic; **Type:** Elf 701-701; **Serial:** D10P00071

Program Name: Tilted Right

Communication System: 5 GHz ; Frequency: 5180 MHz; Duty Cycle: 1:1

Medium parameters used: $f = 5180$ MHz; $\sigma = 4.77$ mho/m; $\epsilon_r = 37.2$; $\rho = 1000$ kg/m³

Phantom section: Right Section

DASY4 Configuration:

- Probe: EX3DV4 - SN3536; ConvF(5.24, 5.24, 5.24); Calibrated: 18.09.2009
- Sensor-Surface: 4mm (Mechanical Surface Detection)
- Electronics: DAE3 Sn335; Calibrated: 10.02.2010
- Phantom: SAM Glycol 1176; Type: Speag; Serial: 1176
- Measurement SW: DASY4, V4.7 Build 80; Postprocessing SW: SEMCAD, V1.8 Build 186

Tilted Right/Area Scan (10x14x1): Measurement grid: dx=15mm, dy=15mm

Maximum value of SAR (measured) = 0.017 mW/g

Tilted Right/Zoom Scan (7x7x7)/Cube 0: Measurement grid: dx=5mm, dy=5mm, dz=5mm

Reference Value = 1.84 V/m; Power Drift = 0.196 dB

Peak SAR (extrapolated) = 0.146 W/kg

SAR(1 g) = 0.029 mW/g; SAR(10 g) = 0.011 mW/g

Maximum value of SAR (measured) = 0.024 mW/g

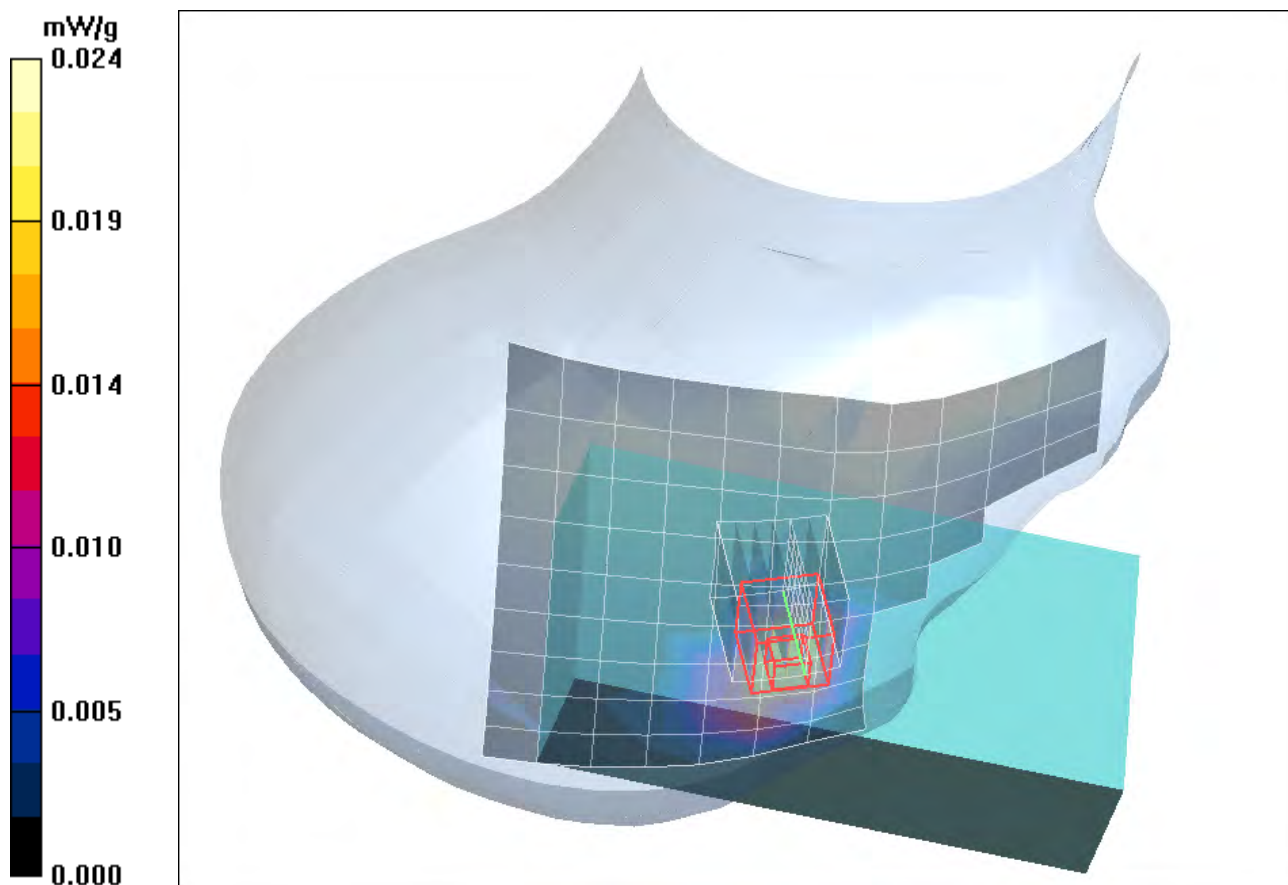

Fig. 58: SAR distribution for IEEE 802.11 a, channel 36, tilted position, right side of head (May 20, 2010; Ambient Temperature: 21.7° C; Liquid Temperature: 21.1° C).

14 SAR Distribution Plots, IEEE 802.11 a Body (5200 MHz Range)

Test Laboratory: IMST GmbH, DASY Blue (I); File Name: [Elf bwhm ch36 15mm dspl up.da4](#)

DUT: Datalogic; Type: Elf 701-701; Serial: D10P00071

Program Name: Body Worn

Communication System: 5 GHz ; Frequency: 5180 MHz; Duty Cycle: 1:1

Medium parameters used: $f = 5180$ MHz; $\sigma = 5.33$ mho/m; $\epsilon_r = 48$; $\rho = 1000$ kg/m³

Phantom section: Flat Section

DASY4 Configuration:

- Probe: EX3DV4 - SN3536; ConvF(4.54, 4.54, 4.54); Calibrated: 18.09.2009

- Sensor-Surface: 2mm (Mechanical Surface Detection)

- Electronics: DAE3 Sn335; Calibrated: 10.02.2010

- Phantom: SAM Glycol 1176; Type: Speag; Serial: 1176

- Measurement SW: DASY4, V4.7 Build 80; Postprocessing SW: SEMCAD, V1.8 Build 186

d=10mm, Pin=250mW/Area Scan (15x19x1): Measurement grid: dx=10mm, dy=10mm

Maximum value of SAR (measured) = 0.092 mW/g

d=10mm, Pin=250mW/Zoom Scan (8x8x8)/Cube 0: Measurement grid: dx=4.3mm, dy=4.3mm, dz=3mm

Reference Value = 1.29 V/m; Power Drift = -0.157 dB

Peak SAR (extrapolated) = 0.216 W/kg

SAR(1 g) = 0.040 mW/g; SAR(10 g) = 0.015 mW/g

Maximum value of SAR (measured) = 0.093 mW/g

d=10mm, Pin=250mW/Zoom Scan (8x8x8)/Cube 1: Measurement grid: dx=4.3mm, dy=4.3mm, dz=3mm

Reference Value = 1.29 V/m; Power Drift = -0.157 dB

Peak SAR (extrapolated) = 0.109 W/kg

SAR(1 g) = 0.035 mW/g; SAR(10 g) = 0.015 mW/g

Maximum value of SAR (measured) = 0.090 mW/g

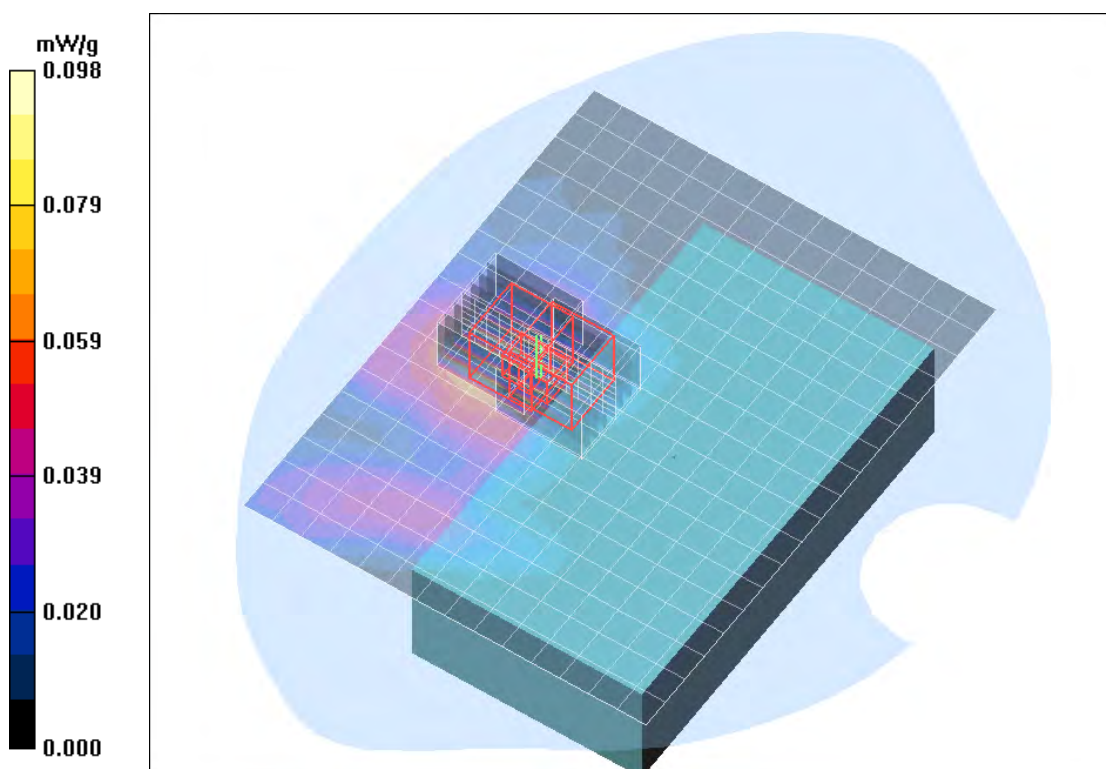

Fig. 59: SAR distribution for IEEE 802.11 a, channel 36, body worn configuration, display towards the phantom, 15 mm distance (May 12, 2010; Ambient Temperature: 21.6° C; Liquid Temperature: 21.2° C).

Test Laboratory: IMST GmbH, DASY Blue (I); File Name: [Elf_bwhm_ch48_15mm_dspl_up.da4](#)

DUT: Datalogic; Type: Elf 701-701; Serial: D10P00071

Program Name: Body Worn

Communication System: 5 GHz ; Frequency: 5240 MHz;Duty Cycle: 1:1

Medium parameters used: $f = 5240$ MHz; $\sigma = 5.38$ mho/m; $\epsilon_r = 47.8$; $\rho = 1000$ kg/m³

Phantom section: Flat Section

DASY4 Configuration:

- Probe: EX3DV4 - SN3536; ConvF(4.54, 4.54, 4.54); Calibrated: 18.09.2009
- Sensor-Surface: 2mm (Mechanical Surface Detection)
- Electronics: DAE3 Sn335; Calibrated: 10.02.2010
- Phantom: SAM Glycol 1176; Type: Speag; Serial: 1176
- Measurement SW: DASY4, V4.7 Build 80; Postprocessing SW: SEMCAD, V1.8 Build 186

d=10mm, Pin=250mW/Area Scan (15x19x1): Measurement grid: dx=10mm, dy=10mm

Maximum value of SAR (measured) = 0.075 mW/g

d=10mm, Pin=250mW/Zoom Scan (8x8x8)/Cube 0: Measurement grid: dx=4.3mm, dy=4.3mm, dz=3mm

Reference Value = 3.03 V/m; Power Drift = -0.169 dB

Peak SAR (extrapolated) = 0.193 W/kg

SAR(1 g) = 0.031 mW/g; SAR(10 g) = 0.012 mW/g

Maximum value of SAR (measured) = 0.073 mW/g

d=10mm, Pin=250mW/Zoom Scan (8x8x8)/Cube 1: Measurement grid: dx=4.3mm, dy=4.3mm, dz=3mm

Reference Value = 3.03 V/m; Power Drift = -0.169 dB

Peak SAR (extrapolated) = 0.169 W/kg

SAR(1 g) = 0.032 mW/g; SAR(10 g) = 0.014 mW/g

Maximum value of SAR (measured) = 0.072 mW/g

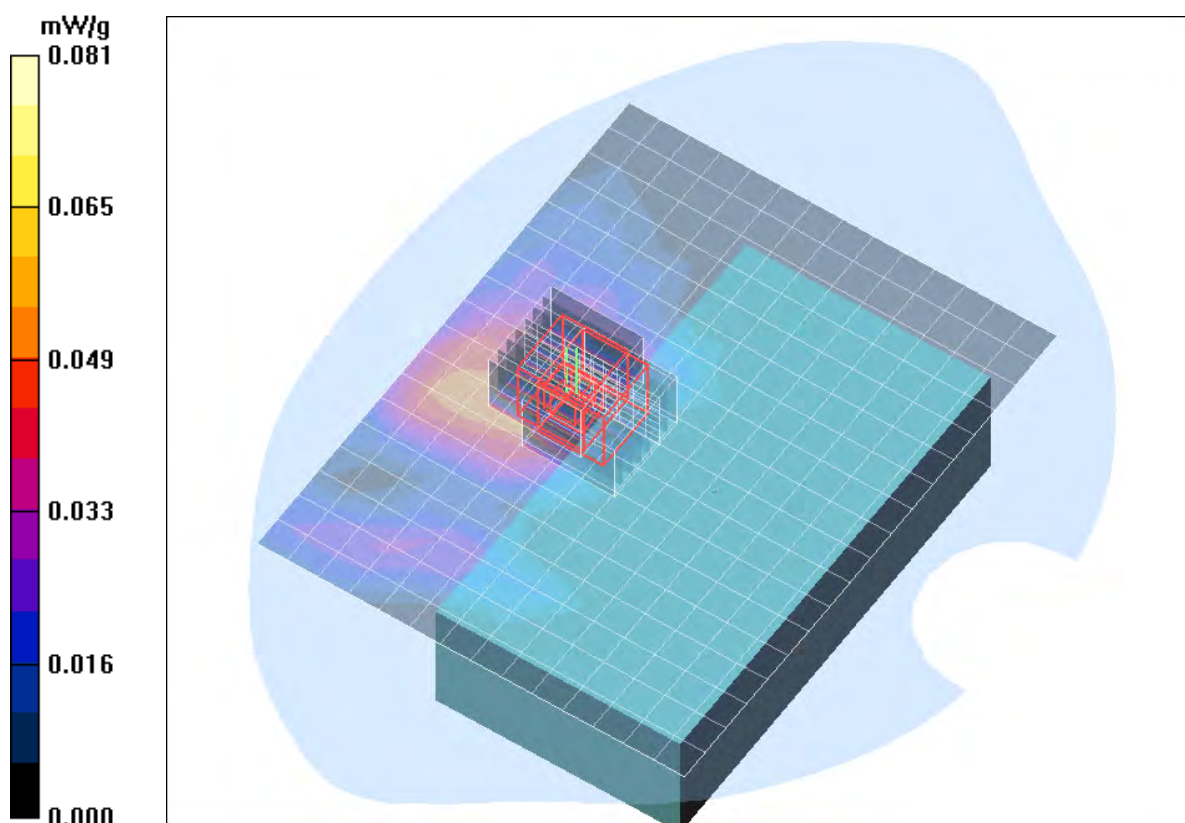

Fig. 60: SAR distribution for IEEE 802.11 a, channel 48, body worn configuration, display towards the phantom, 15 mm distance (May 12, 2010; Ambient Temperature: 21.6° C; Liquid Temperature: 21.2° C).

Test Laboratory: IMST GmbH, DASY Blue (I); File Name: [Elf_bwhm_ch52_15mm_dspl_up.da4](#)

DUT: Datalogic; Type: Elf 701-701; Serial: D10P00071

Program Name: Body Worn

Communication System: 5 GHz ; Frequency: 5260 MHz;Duty Cycle: 1:1

Medium parameters used: $f = 5260$ MHz; $\sigma = 5.39$ mho/m; $\epsilon_r = 47.8$; $\rho = 1000$ kg/m³

Phantom section: Flat Section

DASY4 Configuration:

- Probe: EX3DV4 - SN3536; ConvF(4.37, 4.37, 4.37); Calibrated: 18.09.2009
- Sensor-Surface: 2mm (Mechanical Surface Detection)
- Electronics: DAE3 Sn335; Calibrated: 10.02.2010
- Phantom: SAM Glycol 1176; Type: Speag; Serial: 1176
- Measurement SW: DASY4, V4.7 Build 80; Postprocessing SW: SEMCAD, V1.8 Build 186

d=10mm, Pin=250mW/Area Scan (15x19x1): Measurement grid: dx=10mm, dy=10mm

Maximum value of SAR (measured) = 0.068 mW/g

d=10mm, Pin=250mW/Zoom Scan (8x8x8)/Cube 0: Measurement grid: dx=4.3mm, dy=4.3mm, dz=3mm

Reference Value = 2.53 V/m; Power Drift = 0.199 dB

Peak SAR (extrapolated) = 0.231 W/kg

SAR(1 g) = 0.031 mW/g; SAR(10 g) = 0.013 mW/g

Maximum value of SAR (measured) = 0.069 mW/g

d=10mm, Pin=250mW/Zoom Scan (8x8x8)/Cube 1: Measurement grid: dx=4.3mm, dy=4.3mm, dz=3mm

Reference Value = 2.53 V/m; Power Drift = 0.199 dB

Peak SAR (extrapolated) = 0.128 W/kg

SAR(1 g) = 0.014 mW/g; SAR(10 g) = 0.00463 mW/g

Maximum value of SAR (measured) = 0.027 mW/g

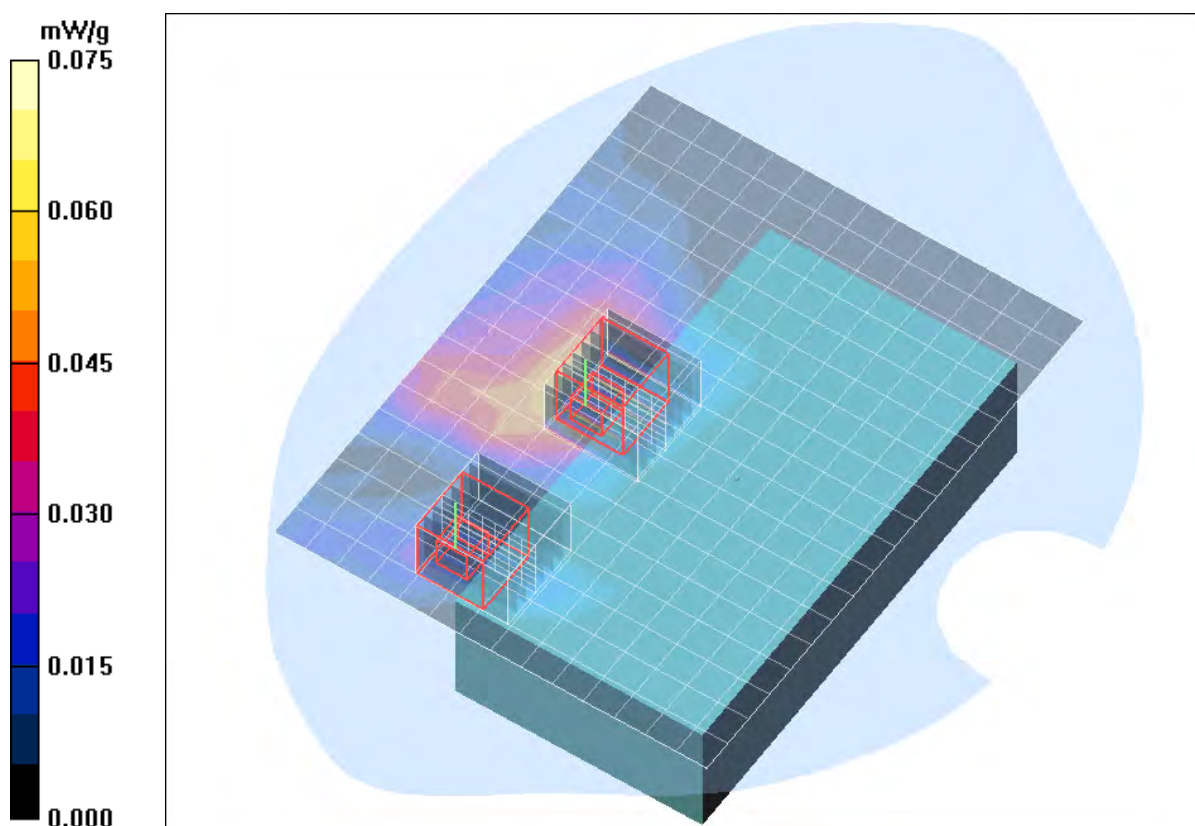

Fig. 61: SAR distribution for IEEE 802.11 a, channel 52, body worn configuration, display towards the phantom, 15 mm distance (May 12, 2010; Ambient Temperature: 21.6° C; Liquid Temperature: 21.2° C).

Test Laboratory: IMST GmbH, DASY Blue (I); File Name: [Elf_bwhm_ch64_15mm_dspl_up.da4](#)

DUT: Datalogic; Type: Elf 701-701; Serial: D10P00071

Program Name: Body Worn

Communication System: 5 GHz ; Frequency: 5320 MHz;Duty Cycle: 1:1

Medium parameters used: $f = 5320$ MHz; $\sigma = 5.49$ mho/m; $\epsilon_r = 47.5$; $\rho = 1000$ kg/m³

Phantom section: Flat Section

DASY4 Configuration:

- Probe: EX3DV4 - SN3536; ConvF(4.37, 4.37, 4.37); Calibrated: 18.09.2009
- Sensor-Surface: 2mm (Mechanical Surface Detection)
- Electronics: DAE3 Sn335; Calibrated: 10.02.2010
- Phantom: SAM Glycol 1176; Type: Speag; Serial: 1176
- Measurement SW: DASY4, V4.7 Build 80; Postprocessing SW: SEMCAD, V1.8 Build 186

d=10mm, Pin=250mW/Area Scan (15x19x1): Measurement grid: dx=10mm, dy=10mm

Maximum value of SAR (measured) = 0.060 mW/g

d=10mm, Pin=250mW/Zoom Scan (8x8x8)/Cube 0: Measurement grid: dx=4.3mm, dy=4.3mm, dz=3mm

Reference Value = 2.20 V/m; Power Drift = -0.176 dB

Peak SAR (extrapolated) = 0.198 W/kg

SAR(1 g) = 0.028 mW/g; SAR(10 g) = 0.011 mW/g

Maximum value of SAR (measured) = 0.068 mW/g

d=10mm, Pin=250mW/Zoom Scan (8x8x8)/Cube 1: Measurement grid: dx=4.3mm, dy=4.3mm, dz=3mm

Reference Value = 2.20 V/m; Power Drift = -0.176 dB

Peak SAR (extrapolated) = 0.177 W/kg

SAR(1 g) = 0.023 mW/g; SAR(10 g) = 0.010 mW/g

Maximum value of SAR (measured) = 0.052 mW/g

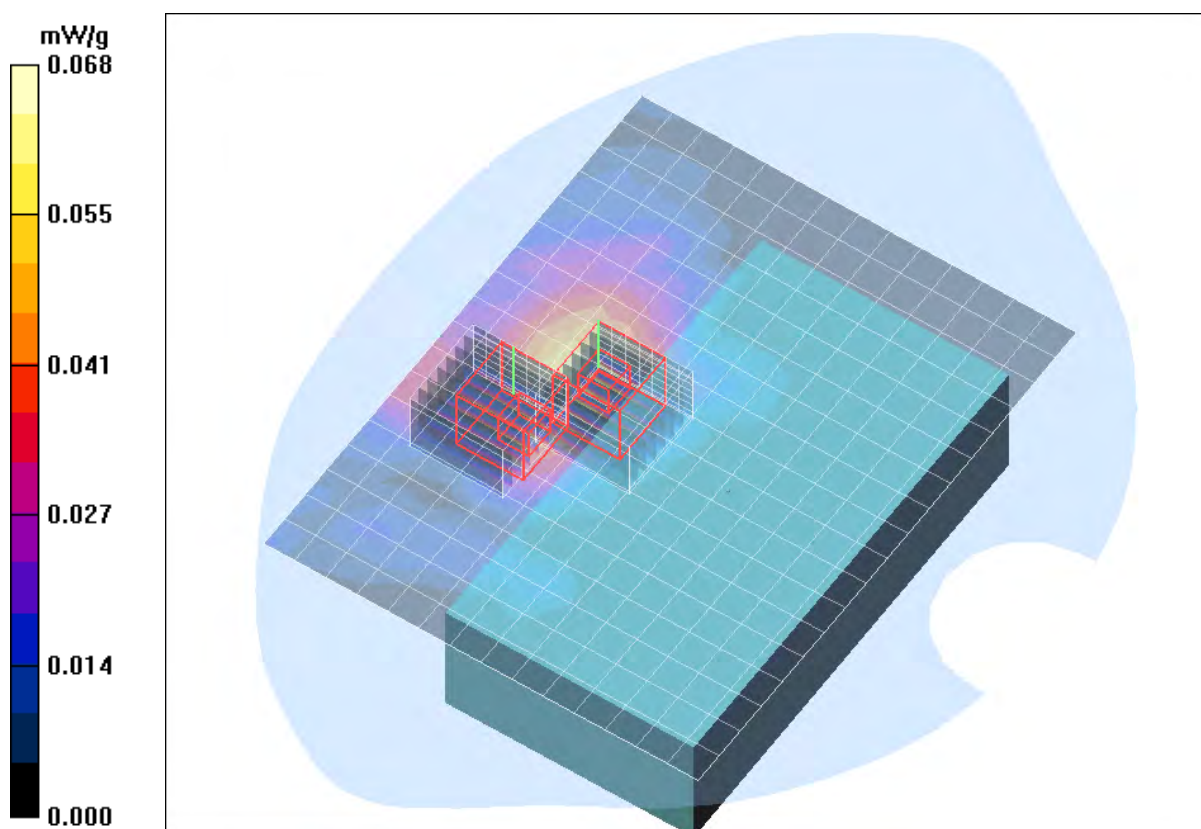

Fig. 62: SAR distribution for IEEE 802.11 a, channel 64, body worn configuration, display towards the phantom, 15 mm distance (May 12, 2010; Ambient Temperature: 21.6° C; Liquid Temperature: 21.2° C).

Test Laboratory: IMST GmbH, DASY Blue (I); File Name: [Elf_bwhm_ch36_15mm_dspl_down.da4](#)

DUT: Datalogic; Type: Elf 701-701; Serial: D10P00071

Program Name: Body Worn

Communication System: 5 GHz ; Frequency: 5180 MHz;Duty Cycle: 1:1

Medium parameters used: $f = 5180$ MHz; $\sigma = 5.33$ mho/m; $\epsilon_r = 48$; $\rho = 1000$ kg/m³

Phantom section: Flat Section

DASY4 Configuration:

- Probe: EX3DV4 - SN3536; ConvF(4.54, 4.54, 4.54); Calibrated: 18.09.2009
- Sensor-Surface: 2mm (Mechanical Surface Detection)
- Electronics: DAE3 Sn335; Calibrated: 10.02.2010
- Phantom: SAM Glycol 1176; Type: Speag; Serial: 1176
- Measurement SW: DASY4, V4.7 Build 80; Postprocessing SW: SEMCAD, V1.8 Build 186

d=10mm, Pin=250mW/Area Scan (15x19x1): Measurement grid: dx=10mm, dy=10mm

Maximum value of SAR (measured) = 0.168 mW/g

d=10mm, Pin=250mW/Zoom Scan (8x8x8)/Cube 0: Measurement grid: dx=4.3mm, dy=4.3mm, dz=3mm

Reference Value = 4.67 V/m; Power Drift = -0.162 dB

Peak SAR (extrapolated) = 0.268 W/kg

SAR(1 g) = 0.089 mW/g; SAR(10 g) = 0.035 mW/g

Maximum value of SAR (measured) = 0.171 mW/g

d=10mm, Pin=250mW/Zoom Scan (8x8x8)/Cube 1: Measurement grid: dx=4.3mm, dy=4.3mm, dz=3mm

Reference Value = 4.67 V/m; Power Drift = -0.162 dB

Peak SAR (extrapolated) = 0.285 W/kg

SAR(1 g) = 0.080 mW/g; SAR(10 g) = 0.030 mW/g

Maximum value of SAR (measured) = 0.167 mW/g

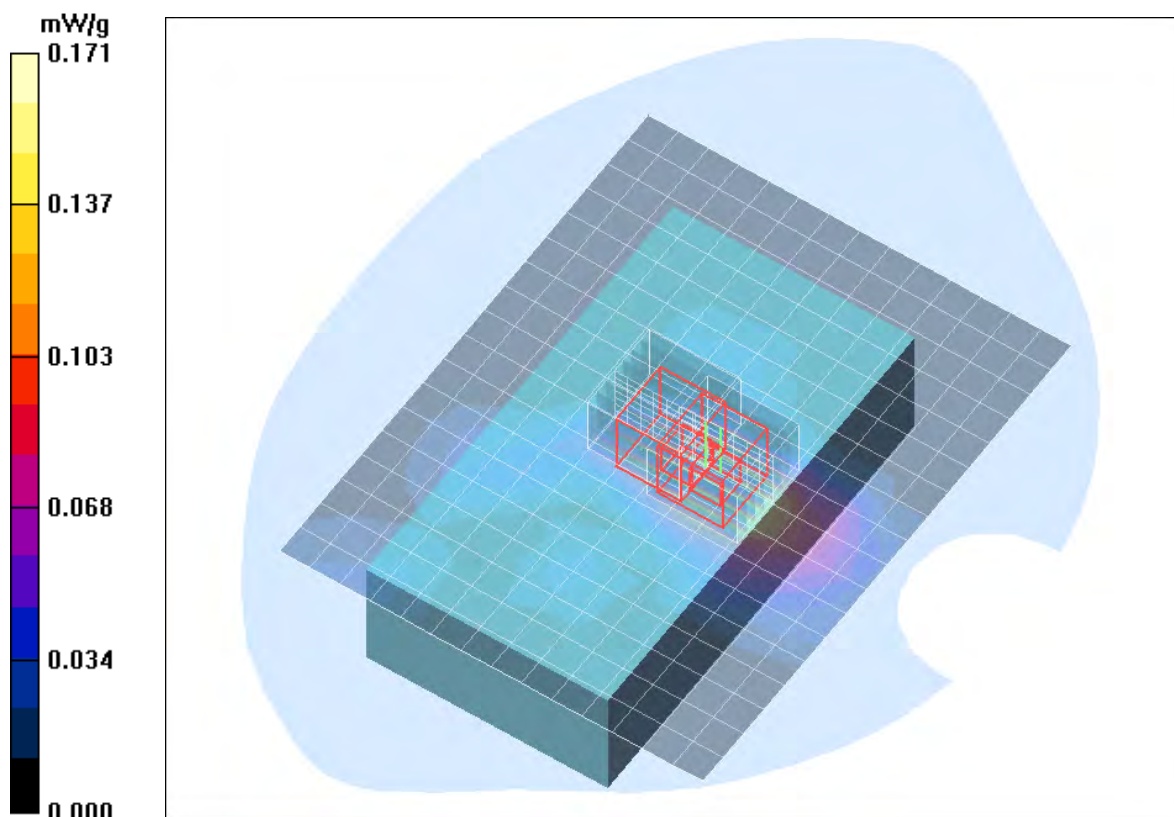

Fig. 63: SAR distribution for IEEE 802.11 a, channel 36, body worn configuration, display towards the ground, 15 mm distance (May 12, 2010; Ambient Temperature: 21.6° C; Liquid Temperature: 21.2° C).

Test Laboratory: IMST GmbH, DASY Blue (I); File Name: [Elf_bwhm_ch48_15mm_dspl_down.da4](#)

DUT: Datalogic; Type: Elf 701-701; Serial: D10P00071

Program Name: Body Worn

Communication System: 5 GHz ; Frequency: 5240 MHz;Duty Cycle: 1:1

Medium parameters used: $f = 5240$ MHz; $\sigma = 5.38$ mho/m; $\epsilon_r = 47.8$; $\rho = 1000$ kg/m³

Phantom section: Flat Section

DASY4 Configuration:

- Probe: EX3DV4 - SN3536; ConvF(4.54, 4.54, 4.54); Calibrated: 18.09.2009
- Sensor-Surface: 2mm (Mechanical Surface Detection)
- Electronics: DAE3 Sn335; Calibrated: 10.02.2010
- Phantom: SAM Glycol 1176; Type: Speag; Serial: 1176
- Measurement SW: DASY4, V4.7 Build 80; Postprocessing SW: SEMCAD, V1.8 Build 186

d=10mm, Pin=250mW/Area Scan (15x19x1): Measurement grid: dx=10mm, dy=10mm

Maximum value of SAR (measured) = 0.156 mW/g

d=10mm, Pin=250mW/Zoom Scan (8x8x8)/Cube 0: Measurement grid: dx=4.3mm, dy=4.3mm, dz=3mm

Reference Value = 4.72 V/m; Power Drift = -0.062 dB

Peak SAR (extrapolated) = 0.188 W/kg

SAR(1 g) = 0.073 mW/g; SAR(10 g) = 0.027 mW/g

Maximum value of SAR (measured) = 0.155 mW/g

d=10mm, Pin=250mW/Zoom Scan (8x8x8)/Cube 1: Measurement grid: dx=4.3mm, dy=4.3mm, dz=3mm

Reference Value = 4.72 V/m; Power Drift = -0.062 dB

Peak SAR (extrapolated) = 0.182 W/kg

SAR(1 g) = 0.059 mW/g; SAR(10 g) = 0.023 mW/g

Maximum value of SAR (measured) = 0.133 mW/g

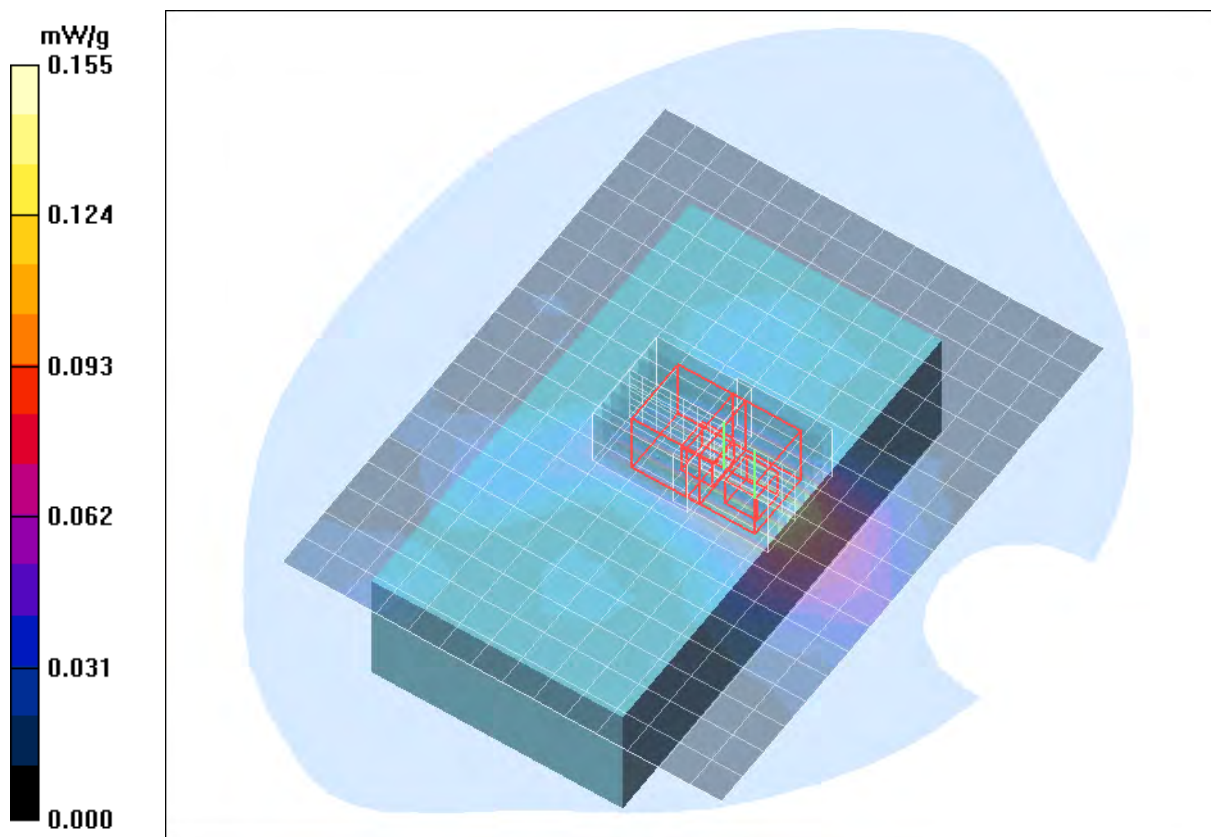

Fig. 64: SAR distribution for IEEE 802.11 a, channel 48, body worn configuration, display towards the ground, 15 mm distance (May 12, 2010; Ambient Temperature: 21.6° C; Liquid Temperature: 21.2° C).

Test Laboratory: IMST GmbH, DASY Blue (I); File Name: [Elf_bwhm_ch52_15mm_dspl_down.da4](#)

DUT: Datalogic; Type: Elf 701-701; Serial: D10P00071
Program Name: Body Worn

Communication System: 5 GHz ; Frequency: 5260 MHz;Duty Cycle: 1:1
Medium parameters used: $f = 5260$ MHz; $\sigma = 5.39$ mho/m; $\epsilon_r = 47.8$; $\rho = 1000$ kg/m³
Phantom section: Flat Section

DASY4 Configuration:

- Probe: EX3DV4 - SN3536; ConvF(4.37, 4.37, 4.37); Calibrated: 18.09.2009
- Sensor-Surface: 2mm (Mechanical Surface Detection)
- Electronics: DAE3 Sn335; Calibrated: 10.02.2010
- Phantom: SAM Glycol 1176; Type: Speag; Serial: 1176
- Measurement SW: DASY4, V4.7 Build 80; Postprocessing SW: SEMCAD, V1.8 Build 186

d=10mm, Pin=250mW/Area Scan (15x19x1): Measurement grid: dx=10mm, dy=10mm

Maximum value of SAR (measured) = 0.148 mW/g

d=10mm, Pin=250mW/Zoom Scan (8x8x8)/Cube 0: Measurement grid: dx=4.3mm, dy=4.3mm, dz=3mm

Reference Value = 4.48 V/m; Power Drift = 0.011 dB

Peak SAR (extrapolated) = 0.167 W/kg

SAR(1 g) = 0.067 mW/g; SAR(10 g) = 0.026 mW/g

Maximum value of SAR (measured) = 0.153 mW/g

d=10mm, Pin=250mW/Zoom Scan (8x8x8)/Cube 1: Measurement grid: dx=4.3mm, dy=4.3mm, dz=3mm

Reference Value = 4.48 V/m; Power Drift = 0.011 dB

Peak SAR (extrapolated) = 0.190 W/kg

SAR(1 g) = 0.047 mW/g; SAR(10 g) = 0.017 mW/g

Maximum value of SAR (measured) = 0.106 mW/g

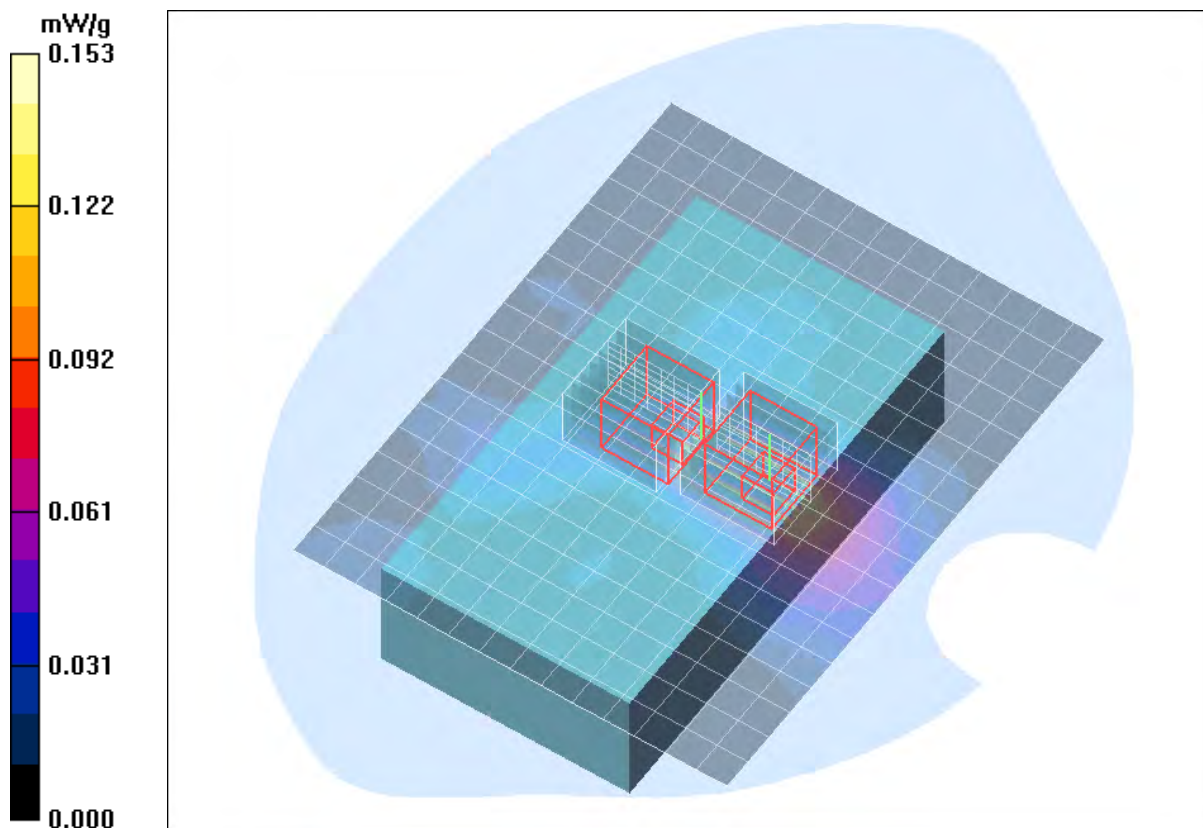

Fig. 65: SAR distribution for IEEE 802.11 a, channel 52, body worn configuration, display towards the ground, 15 mm distance (May 12, 2010; Ambient Temperature: 21.6° C; Liquid Temperature: 21.2° C).

Test Laboratory: IMST GmbH, DASY Blue (I); File Name: [Elf_bwhm_ch64_15mm_dspl_down.da4](#)

DUT: Datalogic; Type: Elf 701-701; Serial: D10P00071
Program Name: Body Worn

Communication System: 5 GHz ; Frequency: 5320 MHz; Duty Cycle: 1:1
Medium parameters used: $f = 5320$ MHz; $\sigma = 5.49$ mho/m; $\epsilon_r = 47.5$; $\rho = 1000$ kg/m³
Phantom section: Flat Section

DASY4 Configuration:

- Probe: EX3DV4 - SN3536; ConvF(4.37, 4.37, 4.37); Calibrated: 18.09.2009
- Sensor-Surface: 2mm (Mechanical Surface Detection) Sensor-Surface: 4mm (Mechanical Surface Detection)
- Electronics: DAE3 Sn335; Calibrated: 10.02.2010
- Phantom: SAM Glycol 1176; Type: Speag; Serial: 1176
- Measurement SW: DASY4, V4.7 Build 80; Postprocessing SW: SEMCAD, V1.8 Build 186

d=10mm, Pin=250mW/Area Scan (15x19x1): Measurement grid: dx=10mm, dy=10mm
Maximum value of SAR (measured) = 0.124 mW/g

d=10mm, Pin=250mW/Zoom Scan (8x8x8)/Cube 0: Measurement grid: dx=4.3mm, dy=4.3mm, dz=3mm

Reference Value = 3.71 V/m; Power Drift = 0.147 dB

Peak SAR (extrapolated) = 0.222 W/kg

SAR(1 g) = 0.055 mW/g; SAR(10 g) = 0.022 mW/g

Maximum value of SAR (measured) = 0.120 mW/g

d=10mm, Pin=250mW/Zoom Scan (8x8x8)/Cube 1: Measurement grid: dx=4.3mm, dy=4.3mm, dz=3mm

Reference Value = 3.71 V/m; Power Drift = 0.147 dB

Peak SAR (extrapolated) = 0.209 W/kg

SAR(1 g) = 0.040 mW/g; SAR(10 g) = 0.016 mW/g

Maximum value of SAR (measured) = 0.097 mW/g

d=10mm, Pin=250mW/Zoom Scan 2 (7x7x7)/Cube 0: Measurement grid: dx=5mm, dy=5mm, dz=5mm

Reference Value = 3.71 V/m; Power Drift = 0.147 dB

Peak SAR (extrapolated) = 0.378 W/kg

SAR(1 g) = 0.073 mW/g; SAR(10 g) = 0.028 mW/g

Maximum value of SAR (measured) = 0.063 mW/g

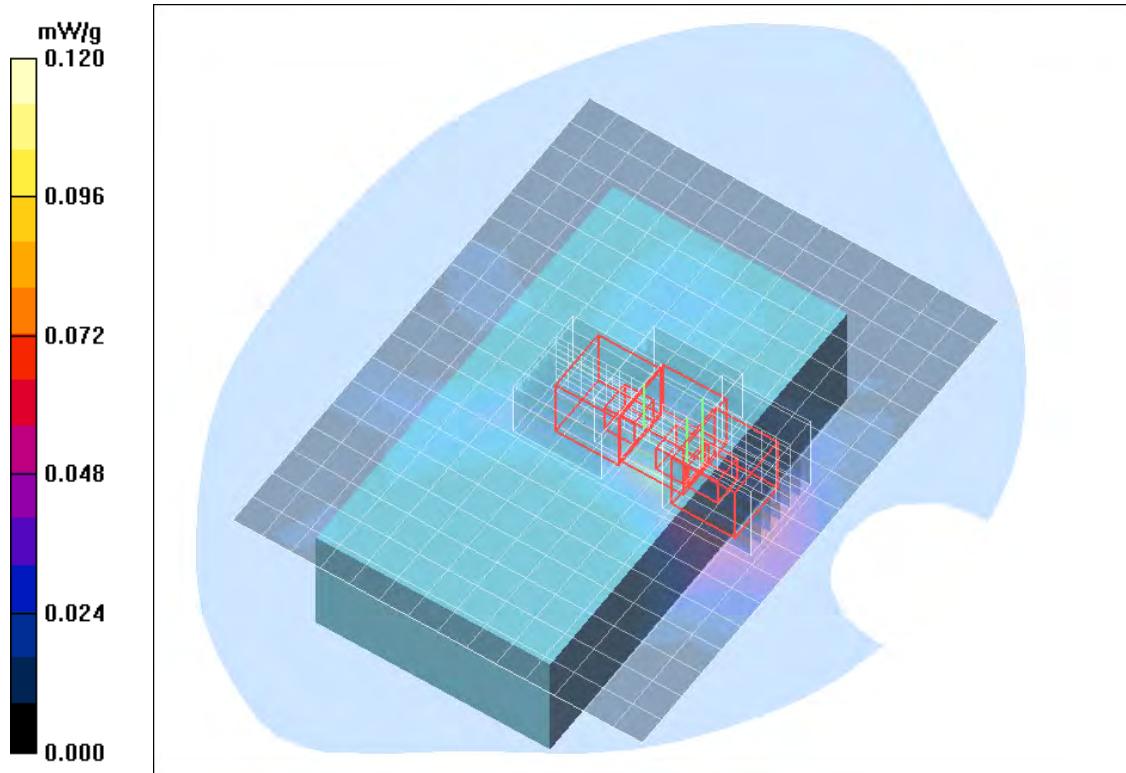

Fig. 66: SAR distribution for IEEE 802.11 a, channel 64, body worn configuration, display towards the ground, 15 mm distance (May 12, 2010; Ambient Temperature: 21.6° C; Liquid Temperature: 21.2° C).

15 SAR Distribution Plots, IEEE 802.11 a Head (5500 MHz Range)

Test Laboratory: IMST GmbH, DASY Blue (I); File Name: [Elf_bwlm_1_CH104.da4](#)

DUT: Datalogic; Type: Elf 701-701; Serial: D10P00071

Program Name: Cheek Left

Communication System: 5 GHz ; Frequency: 5520 MHz;Duty Cycle: 1:1

Medium parameters used: $f = 5520$ MHz; $\sigma = 5.05$ mho/m; $\epsilon_r = 36.4$; $\rho = 1000$ kg/m³

Phantom section: Left Section

DASY4 Configuration:

- Probe: EX3DV4 - SN3536; ConvF(4.93, 4.93, 4.93); Calibrated: 18.09.2009

- Sensor-Surface: 4mm (Mechanical Surface Detection)

- Electronics: DAE3 Sn335; Calibrated: 10.02.2010

- Phantom: SAM Glycol 1176; Type: Speag; Serial: 1176

- Measurement SW: DASY4, V4.7 Build 80; Postprocessing SW: SEMCAD, V1.8 Build 186

Cheek Left/Area Scan (9x14x1): Measurement grid: dx=15mm, dy=15mm

Maximum value of SAR (measured) = 0.125 mW/g

Cheek Left/Zoom Scan (7x7x7)/Cube 0: Measurement grid: dx=5mm, dy=5mm, dz=5mm

Reference Value = 4.98 V/m; Power Drift = 0.196 dB

Peak SAR (extrapolated) = 0.414 W/kg

SAR(1 g) = 0.109 mW/g; SAR(10 g) = 0.038 mW/g

Maximum value of SAR (measured) = 0.126 mW/g

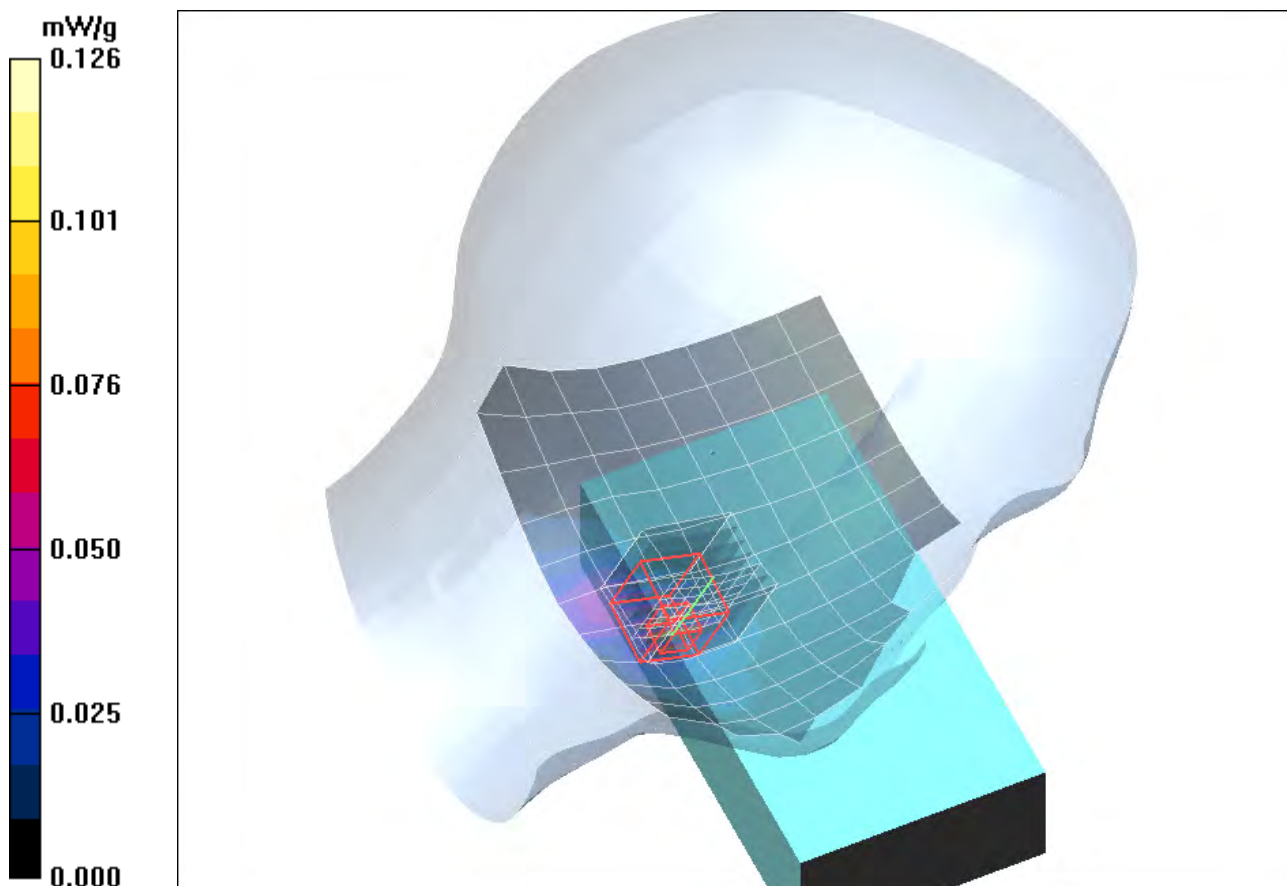

Fig. 67: SAR distribution for IEEE 802.11 a, channel 104, cheek position, left side of head (May 21, 2010; Ambient Temperature: 21.8° C; Liquid Temperature: 21.2° C).

Test Laboratory: IMST GmbH, DASY Blue (I); File Name: [Elf_bwlm_1_CH116.da4](#)

DUT: Datalogic; Type: Elf 701-701; Serial: D10P00071

Program Name: Cheek Left

Communication System: 5 GHz ; Frequency: 5580 MHz;Duty Cycle: 1:1

Medium parameters used: $f = 5580$ MHz; $\sigma = 5.25$ mho/m; $\epsilon_r = 36.1$; $\rho = 1000$ kg/m³

Phantom section: Left Section

DASY4 Configuration:

- Probe: EX3DV4 - SN3536; ConvF(4.93, 4.93, 4.93); Calibrated: 18.09.2009

- Sensor-Surface: 4mm (Mechanical Surface Detection)

- Electronics: DAE3 Sn335; Calibrated: 10.02.2010

- Phantom: SAM Glycol 1176; Type: Speag; Serial: 1176

- Measurement SW: DASY4, V4.7 Build 80; Postprocessing SW: SEMCAD, V1.8 Build 186

Cheek Left/Area Scan (9x14x1): Measurement grid: dx=15mm, dy=15mm

Maximum value of SAR (measured) = 0.141 mW/g

Cheek Left/Zoom Scan (7x7x7)/Cube 0: Measurement grid: dx=5mm, dy=5mm, dz=5mm

Reference Value = 5.43 V/m; Power Drift = 0.026 dB

Peak SAR (extrapolated) = 0.459 W/kg

SAR(1 g) = 0.135 mW/g; SAR(10 g) = 0.046 mW/g

Maximum value of SAR (measured) = 0.146 mW/g

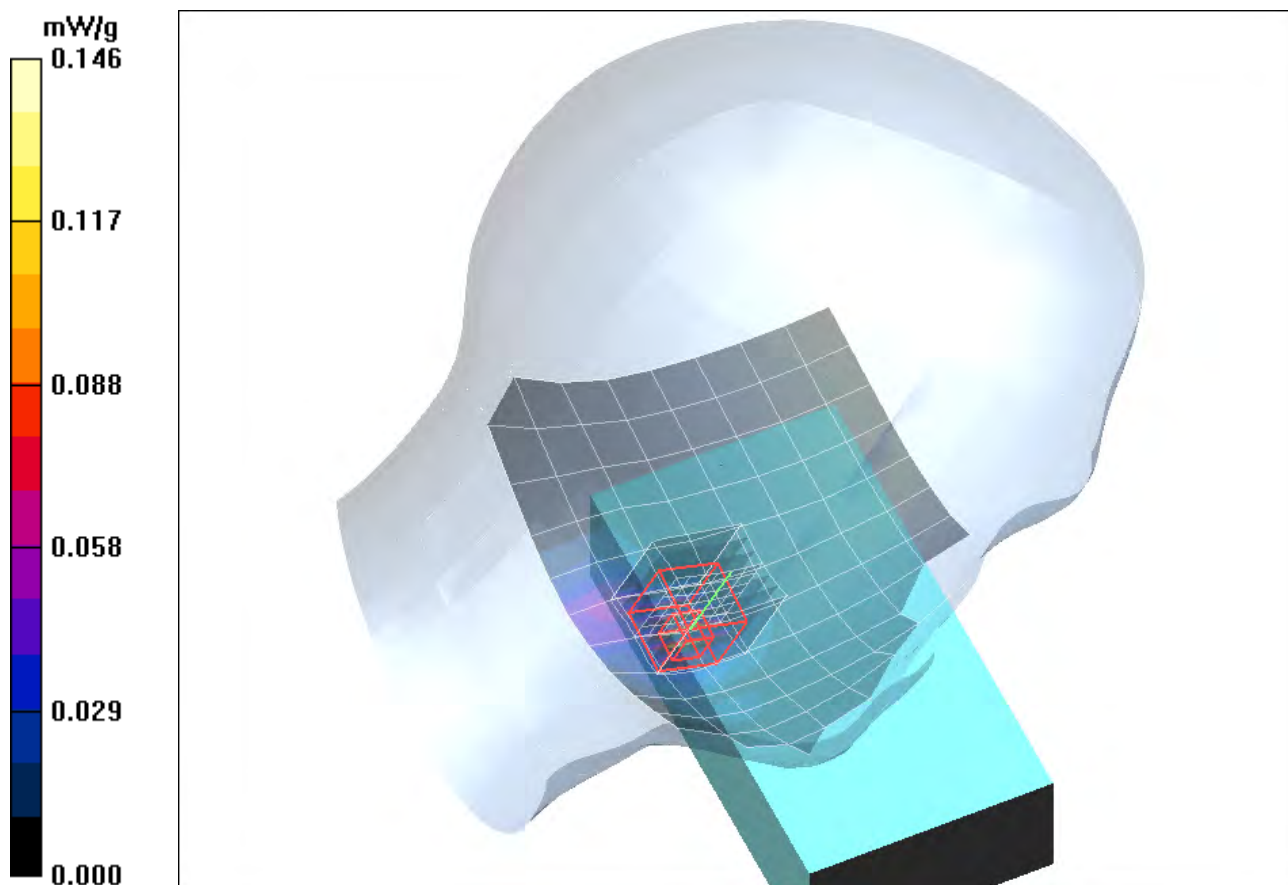

Fig. 68: SAR distribution for IEEE 802.11 a, channel 116, cheek position, left side of head (May 21, 2010; Ambient Temperature: 21.8° C; Liquid Temperature: 21.2° C).

Test Laboratory: IMST GmbH, DASY Blue (I); File Name: [Elf_bwlm_1_CH124.da4](#)

DUT: Datalogic; Type: Elf 701-701; Serial: D10P00071

Program Name: Cheek Left

Communication System: 5 GHz ; Frequency: 5620 MHz;Duty Cycle: 1:1

Medium parameters used: $f = 5620$ MHz; $\sigma = 5.28$ mho/m; $\epsilon_r = 36.3$; $\rho = 1000$ kg/m³

Phantom section: Left Section

DASY4 Configuration:

- Probe: EX3DV4 - SN3536; ConvF(4.93, 4.93, 4.93); Calibrated: 18.09.2009

- Sensor-Surface: 4mm (Mechanical Surface Detection)

- Electronics: DAE3 Sn335; Calibrated: 10.02.2010

- Phantom: SAM Glycol 1176; Type: Speag; Serial: 1176

- Measurement SW: DASY4, V4.7 Build 80; Postprocessing SW: SEMCAD, V1.8 Build 186

Cheek Left/Area Scan (9x14x1): Measurement grid: dx=15mm, dy=15mm

Maximum value of SAR (measured) = 0.142 mW/g

Cheek Left/Zoom Scan (7x7x7)/Cube 0: Measurement grid: dx=5mm, dy=5mm, dz=5mm

Reference Value = 5.50 V/m; Power Drift = 0.049 dB

Peak SAR (extrapolated) = 0.547 W/kg

SAR(1 g) = 0.140 mW/g; SAR(10 g) = 0.049 mW/g

Maximum value of SAR (measured) = 0.143 mW/g

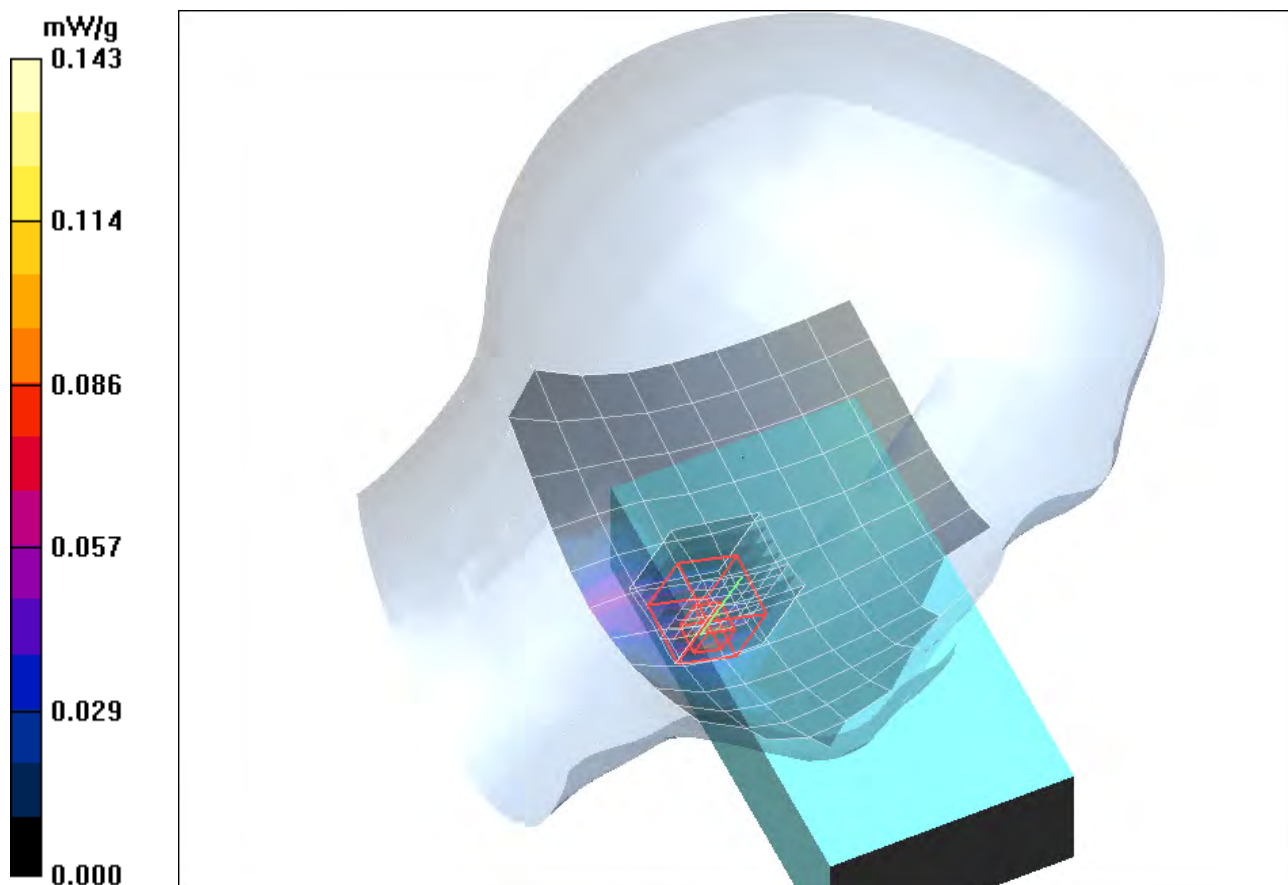

Fig. 69: SAR distribution for IEEE 802.11 a, channel 124, cheek position, left side of head (May 21, 2010; Ambient Temperature: 21.8° C; Liquid Temperature: 21.2° C).

Test Laboratory: IMST GmbH, DASY Blue (I); File Name: [Elf_bwlm_1_CH136.da4](#)

DUT: Datalogic; Type: Elf 701-701; Serial: D10P00071

Program Name: Cheek Left

Communication System: 5 GHz ; Frequency: 5680 MHz; Duty Cycle: 1:1

Medium parameters used: $f = 5680$ MHz; $\sigma = 5.31$ mho/m; $\epsilon_r = 36$; $\rho = 1000$ kg/m³

Phantom section: Left Section

DASY4 Configuration:

- Probe: EX3DV4 - SN3536; ConvF(4.93, 4.93, 4.93); Calibrated: 18.09.2009
- Sensor-Surface: 4mm (Mechanical Surface Detection)
- Electronics: DAE3 Sn335; Calibrated: 10.02.2010
- Phantom: SAM Glycol 1176; Type: Speag; Serial: 1176
- Measurement SW: DASY4, V4.7 Build 80; Postprocessing SW: SEMCAD, V1.8 Build 186

Cheek Left/Area Scan (9x14x1): Measurement grid: dx=15mm, dy=15mm

Maximum value of SAR (measured) = 0.123 mW/g

Cheek Left/Zoom Scan (7x7x7)/Cube 0: Measurement grid: dx=5mm, dy=5mm, dz=5mm

Reference Value = 5.12 V/m; Power Drift = 0.113 dB

Peak SAR (extrapolated) = 0.642 W/kg

SAR(1 g) = 0.153 mW/g; SAR(10 g) = 0.053 mW/g

Maximum value of SAR (measured) = 0.177 mW/g

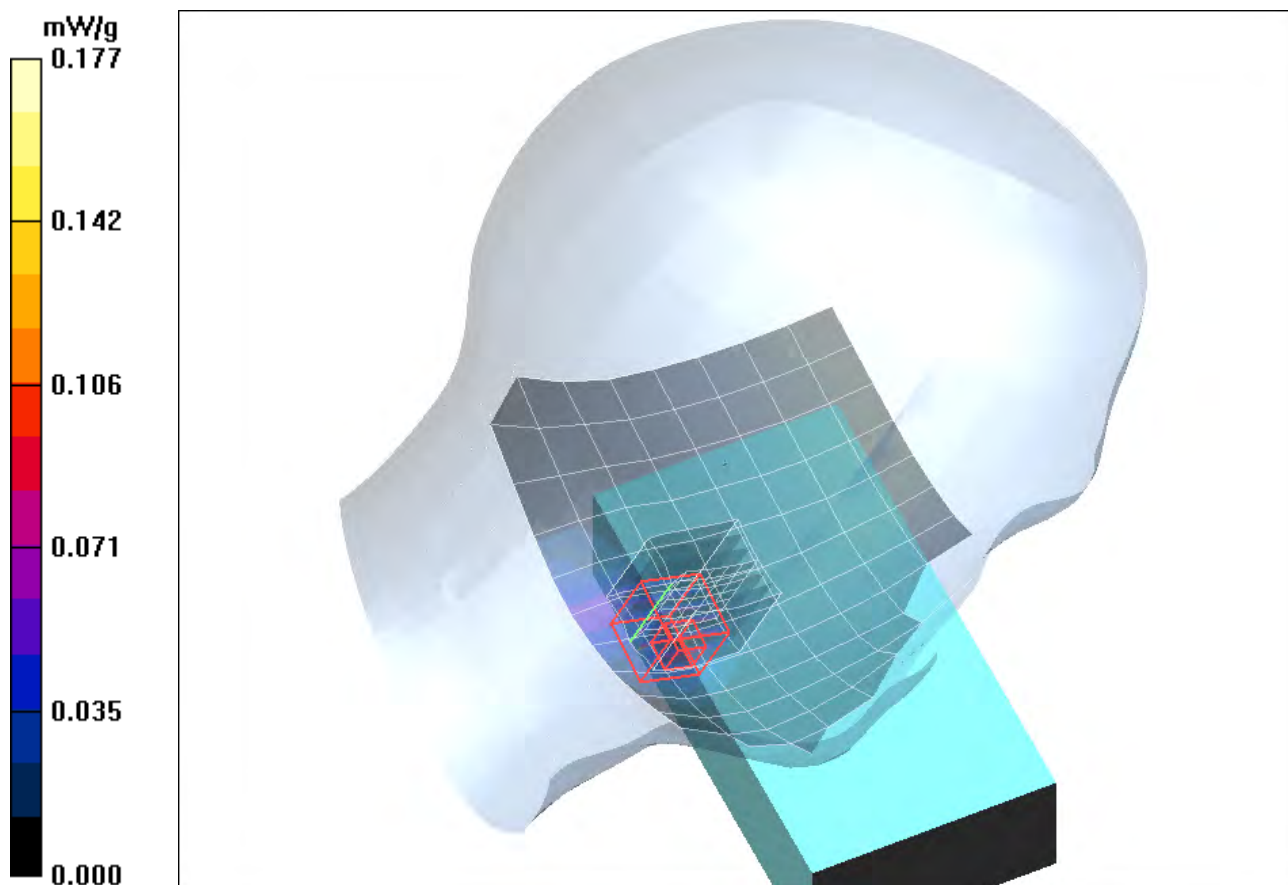

Fig. 70: SAR distribution for IEEE 802.11 a, channel 136, cheek position, left side of head (May 21, 2010; Ambient Temperature: 21.8° C; Liquid Temperature: 21.2° C).

Test Laboratory: IMST GmbH, DASY Blue (I); File Name: [Elf_bwlm_2_CH136.da4](#)

DUT: Datalogic; Type: Elf 701-701; Serial: D10P00071
Program Name: Tilted Left

Communication System: 5 GHz ; Frequency: 5680 MHz;Duty Cycle: 1:1
Medium parameters used: $f = 5680$ MHz; $\sigma = 5.31$ mho/m; $\epsilon_r = 36$; $\rho = 1000$ kg/m³
Phantom section: Left Section

DASY4 Configuration:

- Probe: EX3DV4 - SN3536; ConvF(4.93, 4.93, 4.93); Calibrated: 18.09.2009
- Sensor-Surface: 4mm (Mechanical Surface Detection)
- Electronics: DAE3 Sn335; Calibrated: 10.02.2010
- Phantom: SAM Glycol 1176; Type: Speag; Serial: 1176
- Measurement SW: DASY4, V4.7 Build 80; Postprocessing SW: SEMCAD, V1.8 Build 186

Tilted Left/Area Scan (10x14x1): Measurement grid: dx=15mm, dy=15mm

Maximum value of SAR (measured) = 0.047 mW/g

Tilted Left/Zoom Scan (7x7x7)/Cube 0: Measurement grid: dx=5mm, dy=5mm, dz=5mm

Reference Value = 2.95 V/m; Power Drift = 0.192 dB

Peak SAR (extrapolated) = 0.286 W/kg

SAR(1 g) = 0.057 mW/g; SAR(10 g) = 0.021 mW/g

Maximum value of SAR (measured) = 0.049 mW/g

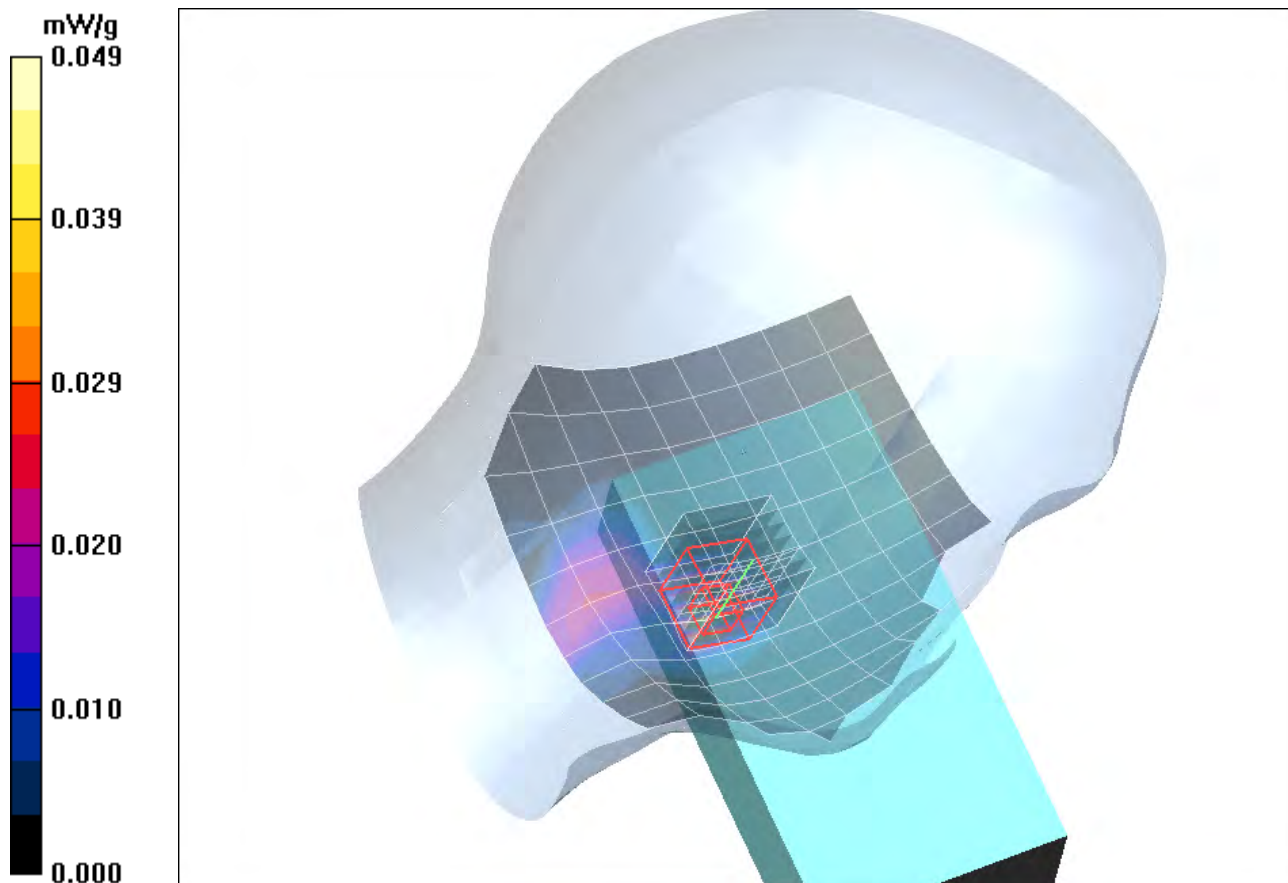

Fig. 71: SAR distribution for IEEE 802.11 a, channel 136, tilted position, left side of head (May 21, 2010; Ambient Temperature: 21.8° C; Liquid Temperature: 21.2° C).

Test Laboratory: IMST GmbH, DASY Blue (I); File Name: [Elf_bwrm_1_CH104.da4](#)

DUT: Datalogic; Type: Elf 701-701; Serial: D10P00071

Program Name: Cheek Right

Communication System: 5 GHz ; Frequency: 5520 MHz;Duty Cycle: 1:1

Medium parameters used: $f = 5520$ MHz; $\sigma = 5.05$ mho/m; $\epsilon_r = 36.4$; $\rho = 1000$ kg/m³

Phantom section: Right Section

DASY4 Configuration:

- Probe: EX3DV4 - SN3536; ConvF(4.93, 4.93, 4.93); Calibrated: 18.09.2009
- Sensor-Surface: 4mm (Mechanical Surface Detection)
- Electronics: DAE3 Sn335; Calibrated: 10.02.2010
- Phantom: SAM Glycol 1176; Type: Speag; Serial: 1176
- Measurement SW: DASY4, V4.7 Build 80; Postprocessing SW: SEMCAD, V1.8 Build 186

Cheek Right/Area Scan (10x14x1): Measurement grid: dx=15mm, dy=15mm

Maximum value of SAR (measured) = 0.062 mW/g

Cheek Right/Zoom Scan (7x7x7)/Cube 0: Measurement grid: dx=5mm, dy=5mm, dz=5mm

Reference Value = 3.69 V/m; Power Drift = -0.116 dB

Peak SAR (extrapolated) = 0.393 W/kg

SAR(1 g) = 0.088 mW/g; SAR(10 g) = 0.036 mW/g

Maximum value of SAR (measured) = 0.080 mW/g

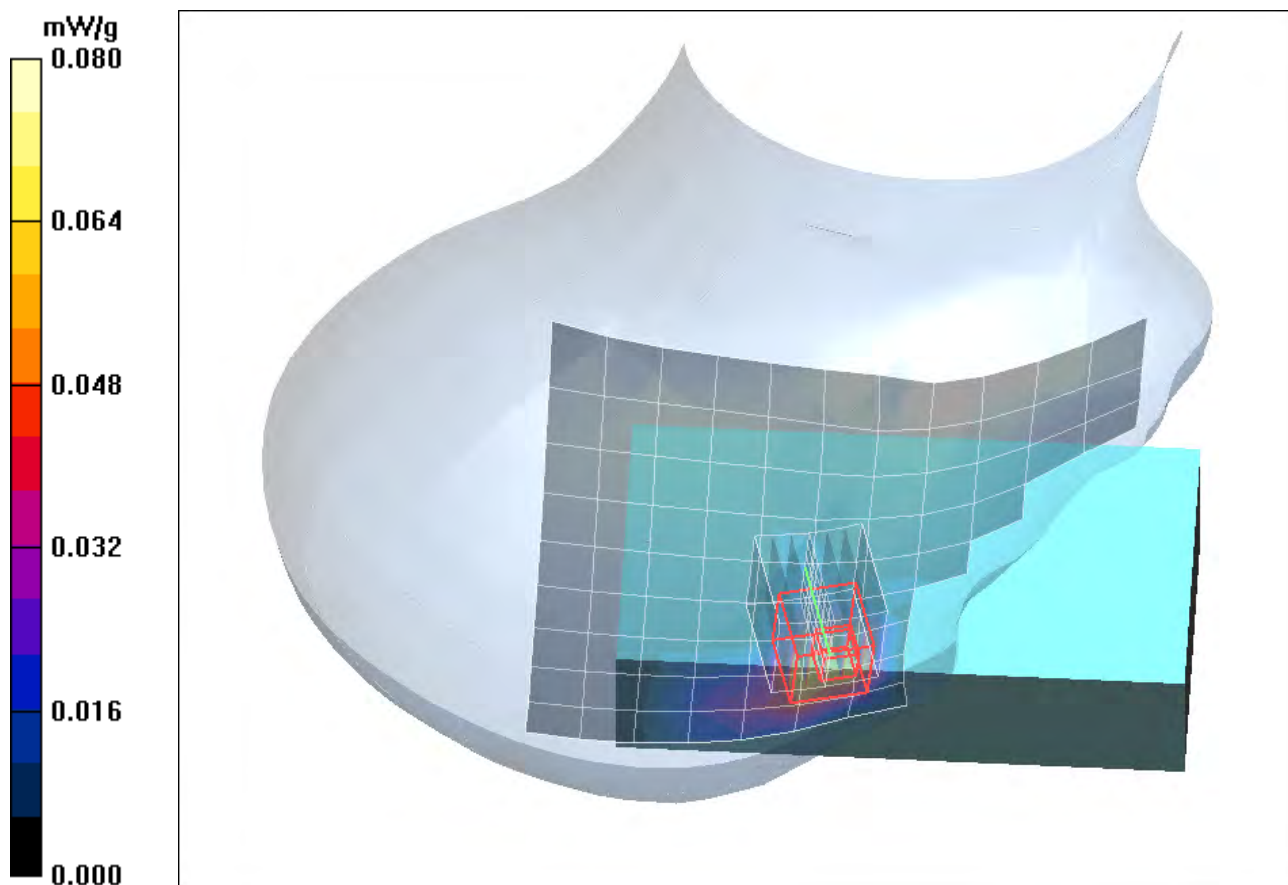

Fig. 72: SAR distribution for IEEE 802.11 a, channel 104, cheek position, right side of head (May 21, 2010; Ambient Temperature: 21.8° C; Liquid Temperature: 21.2° C).

Test Laboratory: IMST GmbH, DASY Blue (I); File Name: [Elf_bwrn_1_CH116.da4](#)

DUT: Datalogic; Type: Elf 701-701; Serial: D10P00071

Program Name: Cheek Right

Communication System: 5 GHz ; Frequency: 5580 MHz;Duty Cycle: 1:1

Medium parameters used: $f = 5580$ MHz; $\sigma = 5.25$ mho/m; $\epsilon_r = 36.1$; $\rho = 1000$ kg/m³

Phantom section: Right Section

DASY4 Configuration:

- Probe: EX3DV4 - SN3536; ConvF(4.93, 4.93, 4.93); Calibrated: 18.09.2009
- Sensor-Surface: 4mm (Mechanical Surface Detection)
- Electronics: DAE3 Sn335; Calibrated: 10.02.2010
- Phantom: SAM Glycol 1176; Type: Speag; Serial: 1176
- Measurement SW: DASY4, V4.7 Build 80; Postprocessing SW: SEMCAD, V1.8 Build 186

Cheek Right/Area Scan (10x14x1): Measurement grid: dx=15mm, dy=15mm

Maximum value of SAR (measured) = 0.074 mW/g

Cheek Right/Zoom Scan (7x7x7)/Cube 0: Measurement grid: dx=5mm, dy=5mm, dz=5mm

Reference Value = 3.86 V/m; Power Drift = 0.133 dB

Peak SAR (extrapolated) = 0.492 W/kg

SAR(1 g) = 0.109 mW/g; SAR(10 g) = 0.044 mW/g

Maximum value of SAR (measured) = 0.096 mW/g

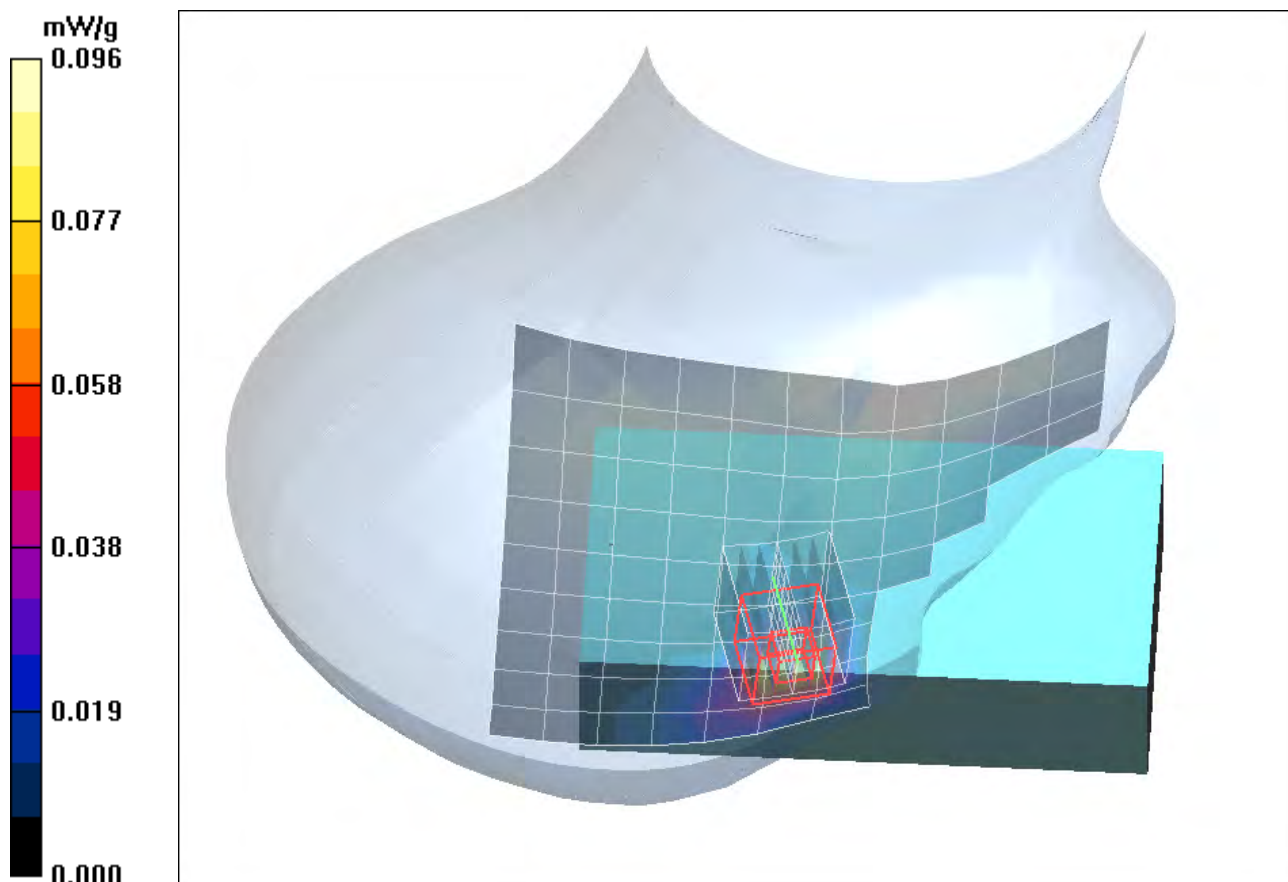

Fig. 73: SAR distribution for IEEE 802.11 a, channel 116, cheek position, right side of head (May 21, 2010; Ambient Temperature: 21.8° C; Liquid Temperature: 21.2° C).

Test Laboratory: IMST GmbH, DASY Blue (I); File Name: [Elf_bwrm_1_CH124.da4](#)

DUT: Datalogic; Type: Elf 701-701; Serial: D10P00071

Program Name: Cheek Right

Communication System: 5 GHz ; Frequency: 5620 MHz; Duty Cycle: 1:1

Medium parameters used: $f = 5620$ MHz; $\sigma = 5.28$ mho/m; $\epsilon_r = 36.3$; $\rho = 1000$ kg/m³

Phantom section: Right Section

DASY4 Configuration:

- Probe: EX3DV4 - SN3536; ConvF(4.93, 4.93, 4.93); Calibrated: 18.09.2009
- Sensor-Surface: 4mm (Mechanical Surface Detection)
- Electronics: DAE3 Sn335; Calibrated: 10.02.2010
- Phantom: SAM Glycol 1176; Type: Speag; Serial: 1176
- Measurement SW: DASY4, V4.7 Build 80; Postprocessing SW: SEMCAD, V1.8 Build 186

Cheek Right/Area Scan (10x14x1): Measurement grid: dx=15mm, dy=15mm

Maximum value of SAR (measured) = 0.062 mW/g

Cheek Right/Zoom Scan (7x7x7)/Cube 0: Measurement grid: dx=5mm, dy=5mm, dz=5mm

Reference Value = 3.58 V/m; Power Drift = 0.167 dB

Peak SAR (extrapolated) = 0.472 W/kg

SAR(1 g) = 0.096 mW/g; SAR(10 g) = 0.038 mW/g

Maximum value of SAR (measured) = 0.078 mW/g

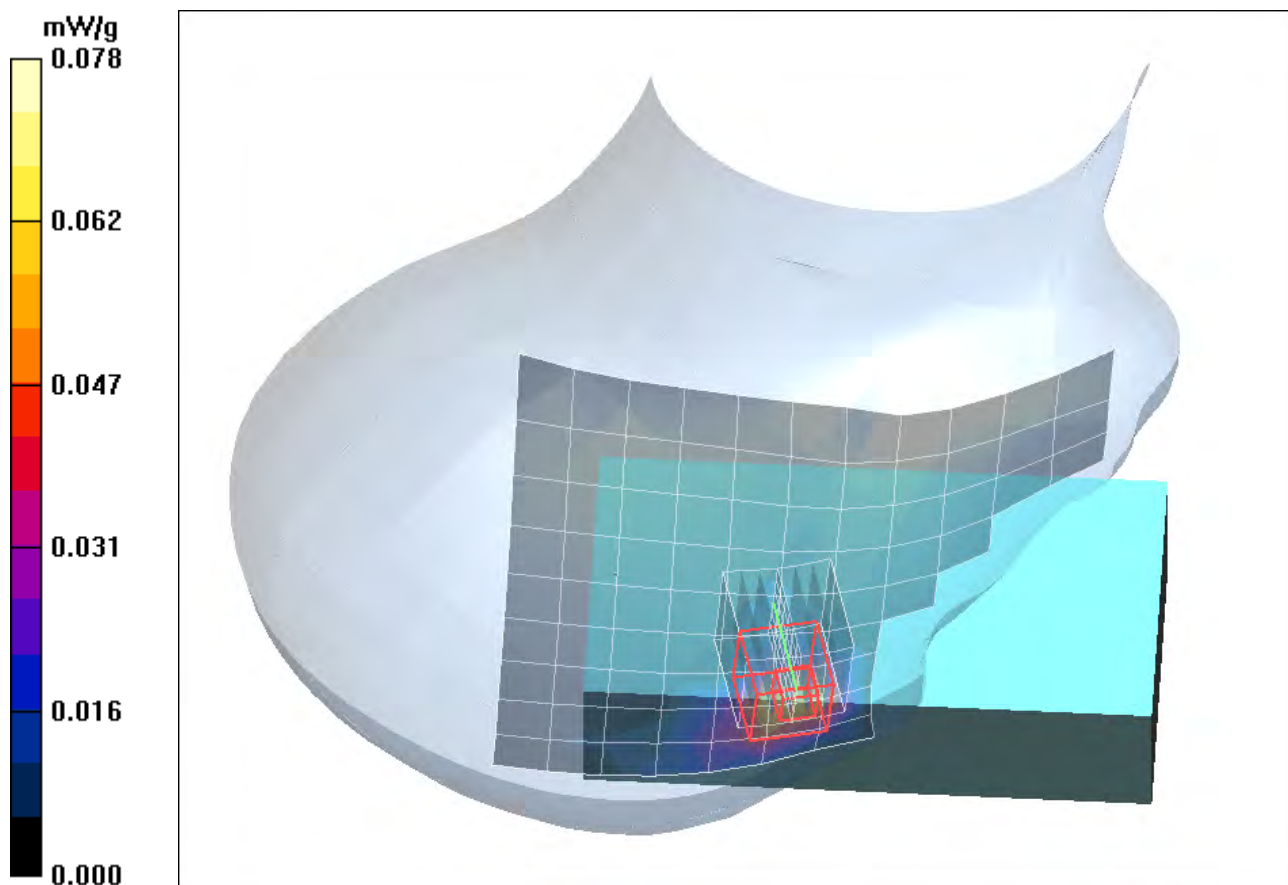

Fig. 74: SAR distribution for IEEE 802.11 a, channel 124, cheek position, right side of head (May 21, 2010; Ambient Temperature: 21.8° C; Liquid Temperature: 21.2° C).

Test Laboratory: IMST GmbH, DASY Blue (I); **File Name:** [Elf_bwrm_1_CH136.da4](#)

DUT: Datalogic; **Type:** Elf 701-701; **Serial:** D10P00071

Program Name: Cheek Right

Communication System: 5 GHz ; Frequency: 5680 MHz; Duty Cycle: 1:1

Medium parameters used: $f = 5680$ MHz; $\sigma = 5.31$ mho/m; $\epsilon_r = 36$; $\rho = 1000$ kg/m³

Phantom section: Right Section

DASY4 Configuration:

- Probe: EX3DV4 - SN3536; ConvF(4.93, 4.93, 4.93); Calibrated: 18.09.2009
- Sensor-Surface: 4mm (Mechanical Surface Detection)
- Electronics: DAE3 Sn335; Calibrated: 10.02.2010
- Phantom: SAM Glycol 1176; Type: Speag; Serial: 1176
- Measurement SW: DASY4, V4.7 Build 80; Postprocessing SW: SEMCAD, V1.8 Build 186

Cheek Right/Area Scan (10x14x1): Measurement grid: dx=15mm, dy=15mm

Maximum value of SAR (measured) = 0.067 mW/g

Cheek Right/Zoom Scan (7x7x7)/Cube 0: Measurement grid: dx=5mm, dy=5mm, dz=5mm

Reference Value = 3.71 V/m; Power Drift = 0.090 dB

Peak SAR (extrapolated) = 0.527 W/kg

SAR(1 g) = 0.110 mW/g; SAR(10 g) = 0.043 mW/g

Maximum value of SAR (measured) = 0.085 mW/g

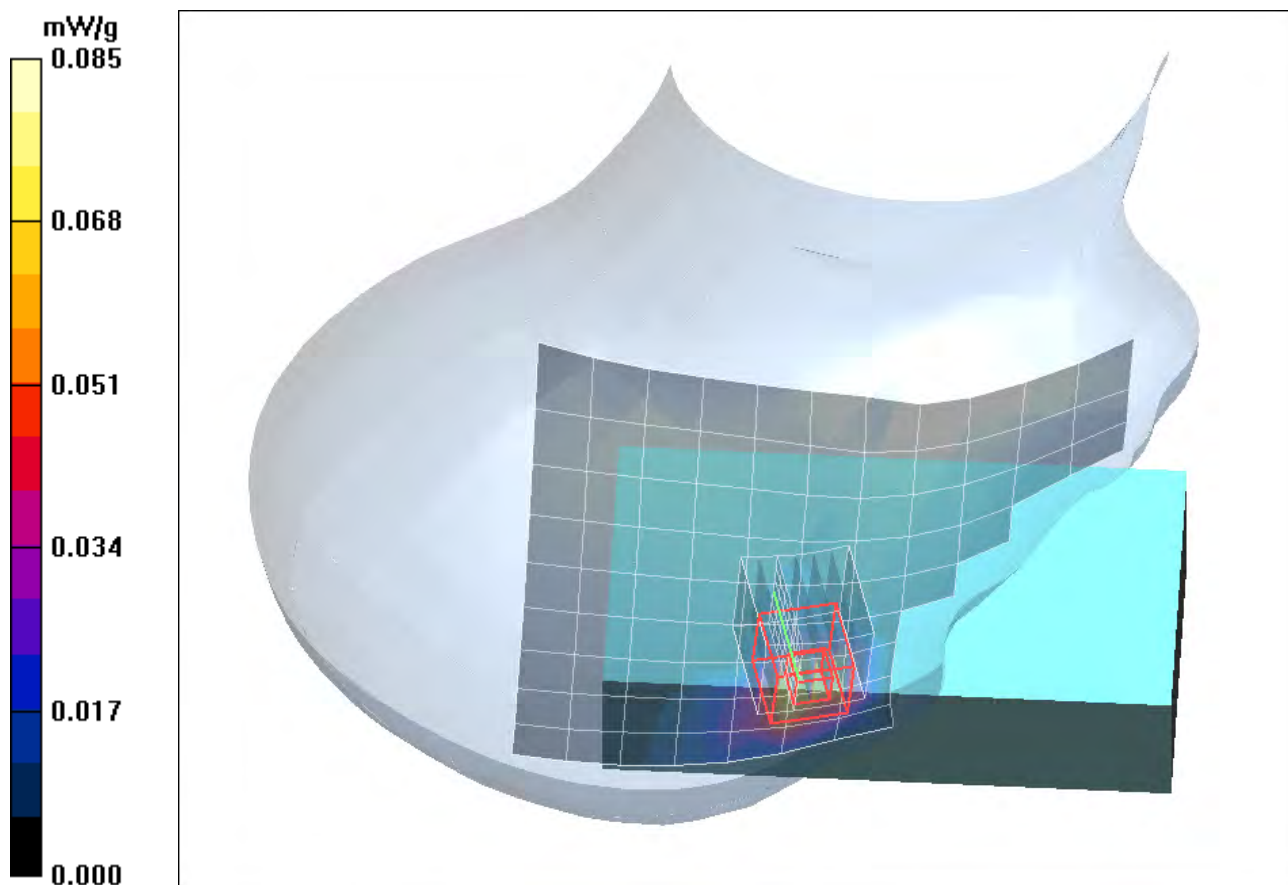

Fig. 75: SAR distribution for IEEE 802.11 a, channel 136, cheek position, right side of head (May 21, 2010; Ambient Temperature: 21.8° C; Liquid Temperature: 21.2° C).

Test Laboratory: IMST GmbH, DASY Blue (I); File Name: [Elf_bwrm_2_CH136.da4](#)

DUT: Datalogic; Type: Elf 701-701; Serial: D10P00071

Program Name: Tilted Right

Communication System: 5 GHz ; Frequency: 5680 MHz; Duty Cycle: 1:1

Medium parameters used: $f = 5680$ MHz; $\sigma = 5.31$ mho/m; $\epsilon_r = 36$; $\rho = 1000$ kg/m³

Phantom section: Right Section

DASY4 Configuration:

- Probe: EX3DV4 - SN3536; ConvF(4.93, 4.93, 4.93); Calibrated: 18.09.2009

- Sensor-Surface: 4mm (Mechanical Surface Detection)

- Electronics: DAE3 Sn335; Calibrated: 10.02.2010

- Phantom: SAM Glycol 1176; Type: Speag; Serial: 1176

- Measurement SW: DASY4, V4.7 Build 80; Postprocessing SW: SEMCAD, V1.8 Build 186

Tilted Right/Area Scan (10x14x1): Measurement grid: dx=15mm, dy=15mm

Maximum value of SAR (measured) = 0.030 mW/g

Tilted Right/Zoom Scan (7x7x7)/Cube 0: Measurement grid: dx=5mm, dy=5mm, dz=5mm

Reference Value = 2.34 V/m; Power Drift = 0.056 dB

Peak SAR (extrapolated) = 0.197 W/kg

SAR(1 g) = 0.041 mW/g; SAR(10 g) = 0.016 mW/g

Maximum value of SAR (measured) = 0.033 mW/g

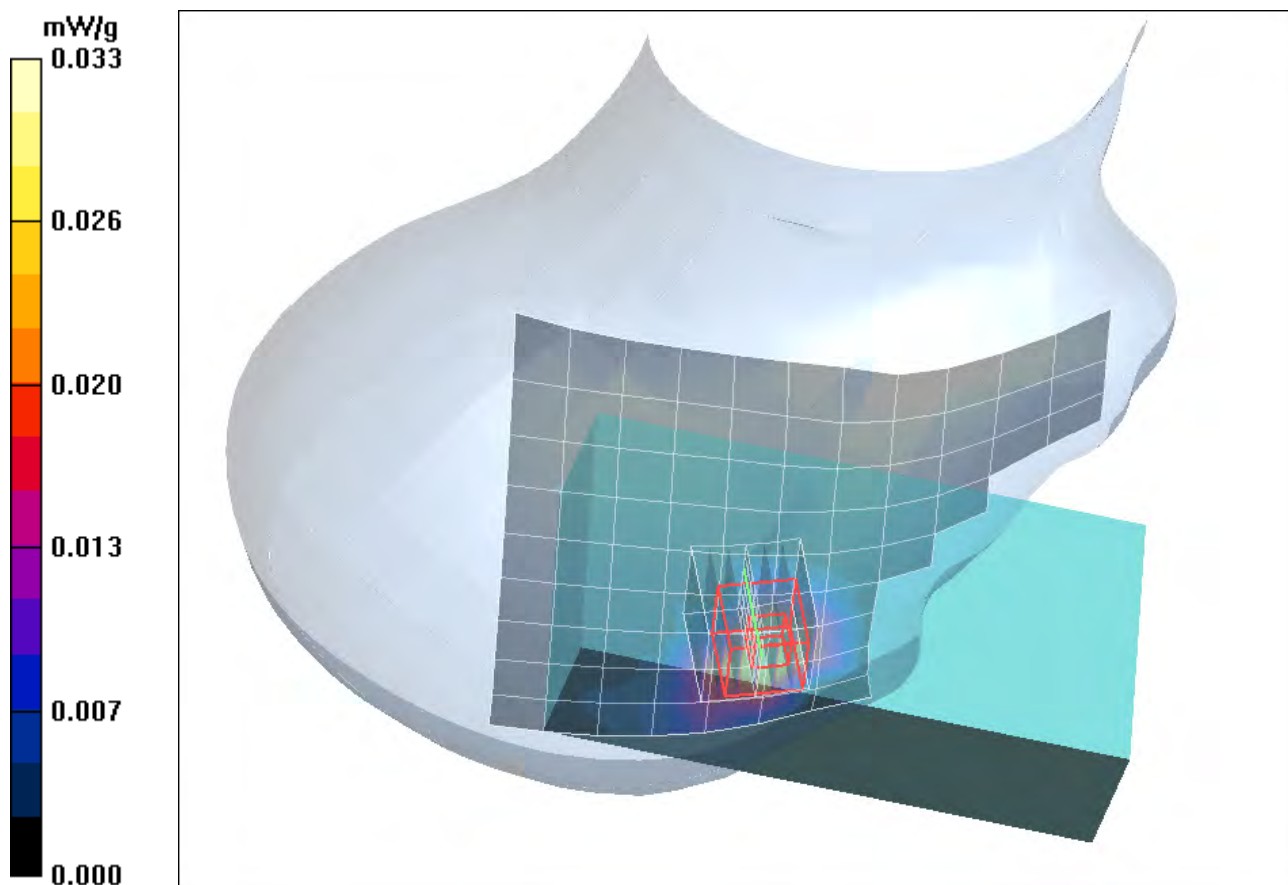

Fig. 76: SAR distribution for IEEE 802.11 a, channel 136, tilted position, right side of head (May 21, 2010; Ambient Temperature: 21.8° C; Liquid Temperature: 21.2° C).

16 SAR Distribution Plots, IEEE 802.11 a Body (5500 MHz Range)

Test Laboratory: IMST GmbH, DASY Blue (I); File Name: [Elf_bwhm_ch104_15mm_dspl_up.da4](#)

DUT: Datalogic; Type: Elf 701-701; Serial: D10P00071
Program Name: Body Worn

Communication System: 5 GHz ; Frequency: 5520 MHz;Duty Cycle: 1:1
Medium parameters used: $f = 5520$ MHz; $\sigma = 5.91$ mho/m; $\epsilon_r = 47.2$; $\rho = 1000$ kg/m³
Phantom section: Flat Section

DASY4 Configuration:

- Probe: EX3DV4 - SN3536; ConvF(4.22, 4.22, 4.22); Calibrated: 18.09.2009
- Sensor-Surface: 2mm (Mechanical Surface Detection)
- Electronics: DAE3 Sn335; Calibrated: 10.02.2010
- Phantom: SAM Glycol 1176; Type: Speag; Serial: 1176
- Measurement SW: DASY4, V4.7 Build 80; Postprocessing SW: SEMCAD, V1.8 Build 186

d=10mm, Pin=250mW/Area Scan (16x18x1): Measurement grid: dx=10mm, dy=10mm

Maximum value of SAR (measured) = 0.083 mW/g

d=10mm, Pin=250mW/Zoom Scan (8x8x8)/Cube 0: Measurement grid: dx=4.3mm, dy=4.3mm, dz=3mm

Reference Value = 2.69 V/m; Power Drift = -0.010 dB

Peak SAR (extrapolated) = 0.142 W/kg

SAR(1 g) = 0.037 mW/g; SAR(10 g) = 0.016 mW/g

Maximum value of SAR (measured) = 0.081 mW/g

d=10mm, Pin=250mW/Zoom Scan (8x8x8)/Cube 1: Measurement grid: dx=4.3mm, dy=4.3mm, dz=3mm

Reference Value = 2.69 V/m; Power Drift = -0.010 dB

Peak SAR (extrapolated) = 0.244 W/kg

SAR(1 g) = 0.031 mW/g; SAR(10 g) = 0.012 mW/g

Maximum value of SAR (measured) = 0.074 mW/g

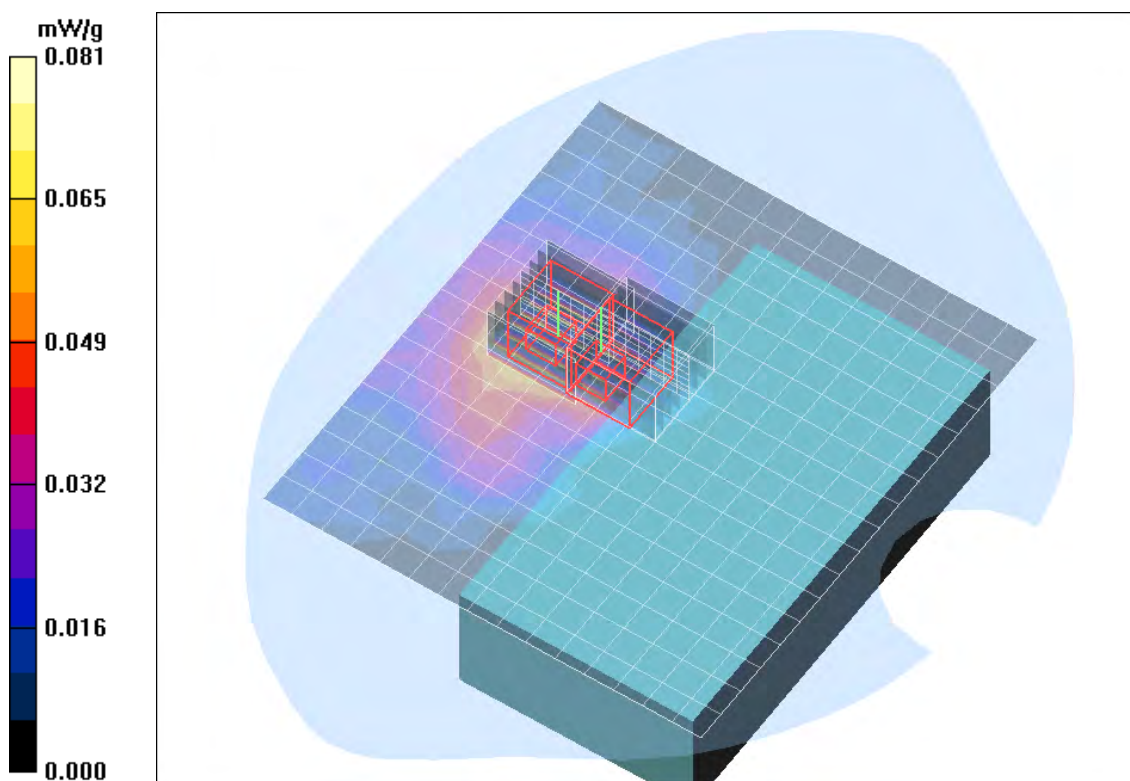

Fig. 77: SAR distribution for IEEE 802.11 a, channel 104, body worn configuration, display towards the phantom, 15 mm distance (May 18, 2010; Ambient Temperature: 21.9° C; Liquid Temperature: 21.3° C).

Test Laboratory: IMST GmbH, DASY Blue (I); File Name: [Elf_bwhm_ch116_15mm_dspl_up.da4](#)

DUT: Datalogic; Type: Elf 701-701; Serial: D10P00071

Program Name: Body Worn

Communication System: 5 GHz ; Frequency: 5580 MHz; Duty Cycle: 1:1

Medium parameters used: $f = 5580$ MHz; $\sigma = 5.95$ mho/m; $\epsilon_r = 47.1$; $\rho = 1000$ kg/m³

Phantom section: Flat Section

DASY4 Configuration:

- Probe: EX3DV4 - SN3536; ConvF(4.22, 4.22, 4.22); Calibrated: 18.09.2009

- Sensor-Surface: 2mm (Mechanical Surface Detection)

- Electronics: DAE3 Sn335; Calibrated: 10.02.2010

- Phantom: SAM Glycol 1176; Type: Speag; Serial: 1176

- Measurement SW: DASY4, V4.7 Build 80; Postprocessing SW: SEMCAD, V1.8 Build 186

d=10mm, Pin=250mW/Area Scan (16x18x1): Measurement grid: dx=10mm, dy=10mm

Maximum value of SAR (measured) = 0.073 mW/g

d=10mm, Pin=250mW/Zoom Scan (8x8x8)/Cube 0: Measurement grid: dx=4.3mm, dy=4.3mm, dz=3mm

Reference Value = 2.62 V/m; Power Drift = 0.025 dB

Peak SAR (extrapolated) = 0.219 W/kg

SAR(1 g) = 0.031 mW/g; SAR(10 g) = 0.012 mW/g

Maximum value of SAR (measured) = 0.079 mW/g

d=10mm, Pin=250mW/Zoom Scan (8x8x8)/Cube 1: Measurement grid: dx=4.3mm, dy=4.3mm, dz=3mm

Reference Value = 2.62 V/m; Power Drift = 0.025 dB

Peak SAR (extrapolated) = 0.280 W/kg

SAR(1 g) = 0.037 mW/g; SAR(10 g) = 0.016 mW/g

Maximum value of SAR (measured) = 0.081 mW/g

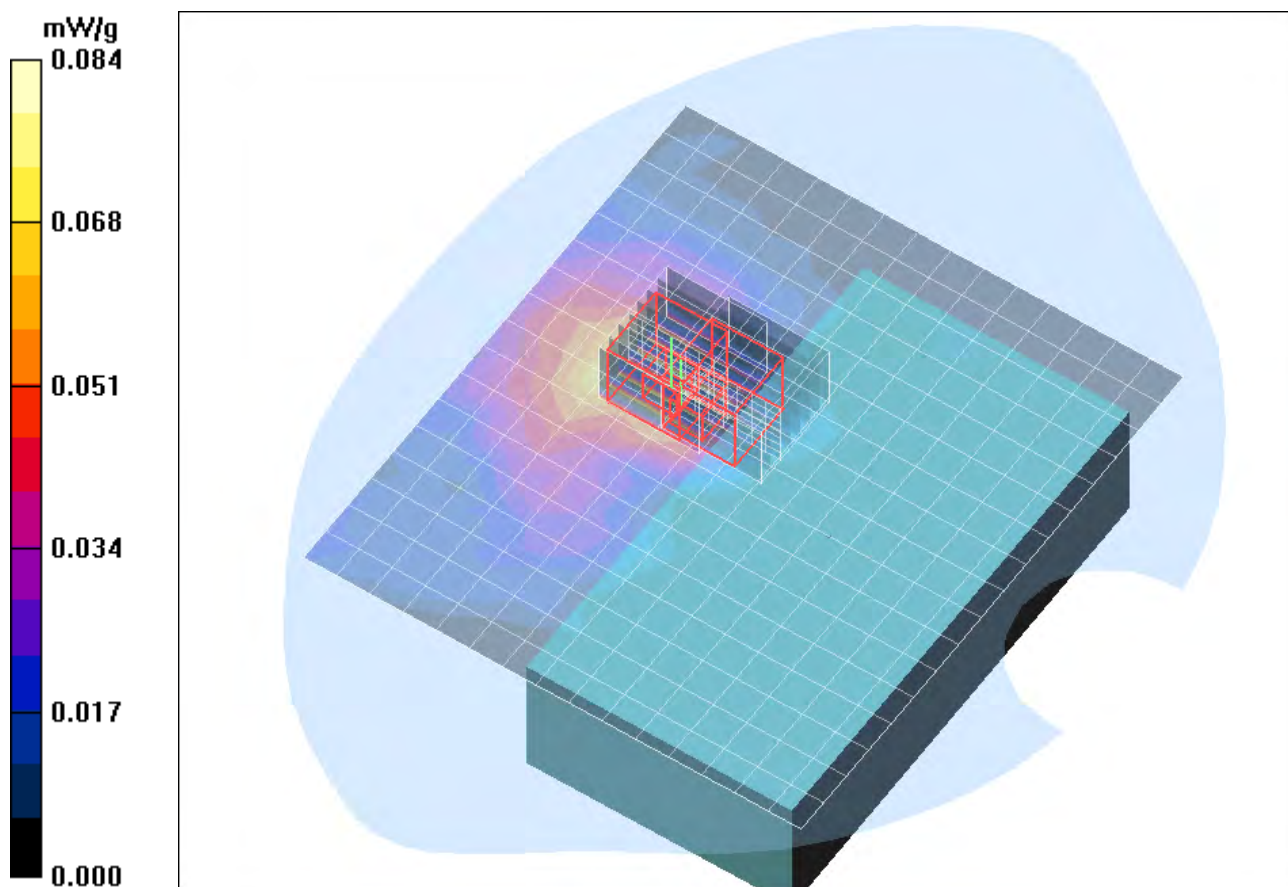

Fig. 78: SAR distribution for IEEE 802.11 a, channel 116, body worn configuration, display towards the phantom, 15 mm distance (May 18, 2010; Ambient Temperature: 21.9° C; Liquid Temperature: 21.3° C).

Test Laboratory: IMST GmbH, DASY Blue (I); File Name: [Elf_bwhm_ch124_15mm_dspl_up.da4](#)

DUT: Datalogic; Type: Elf 701-701; Serial: D10P00071

Program Name: Body Worn

Communication System: 5 GHz ; Frequency: 5620 MHz; Duty Cycle: 1:1

Medium parameters used: $f = 5620$ MHz; $\sigma = 5.96$ mho/m; $\epsilon_r = 47$; $\rho = 1000$ kg/m³

Phantom section: Flat Section

DASY4 Configuration:

- Probe: EX3DV4 - SN3536; ConvF(4.22, 4.22, 4.22); Calibrated: 18.09.2009

- Sensor-Surface: 2mm (Mechanical Surface Detection)

- Electronics: DAE3 Sn335; Calibrated: 10.02.2010

- Phantom: SAM Glycol 1176; Type: Speag; Serial: 1176

- Measurement SW: DASY4, V4.7 Build 80; Postprocessing SW: SEMCAD, V1.8 Build 186

d=10mm, Pin=250mW/Area Scan (16x18x1): Measurement grid: dx=10mm, dy=10mm

Maximum value of SAR (measured) = 0.072 mW/g

d=10mm, Pin=250mW/Zoom Scan (8x8x8)/Cube 0: Measurement grid: dx=4.3mm, dy=4.3mm, dz=3mm

Reference Value = 2.38 V/m; Power Drift = 0.140 dB

Peak SAR (extrapolated) = 0.239 W/kg

SAR(1 g) = 0.034 mW/g; SAR(10 g) = 0.013 mW/g

Maximum value of SAR (measured) = 0.077 mW/g

d=10mm, Pin=250mW/Zoom Scan (8x8x8)/Cube 1: Measurement grid: dx=4.3mm, dy=4.3mm, dz=3mm

Reference Value = 2.38 V/m; Power Drift = 0.140 dB

Peak SAR (extrapolated) = 0.263 W/kg

SAR(1 g) = 0.036 mW/g; SAR(10 g) = 0.014 mW/g

Maximum value of SAR (measured) = 0.080 mW/g

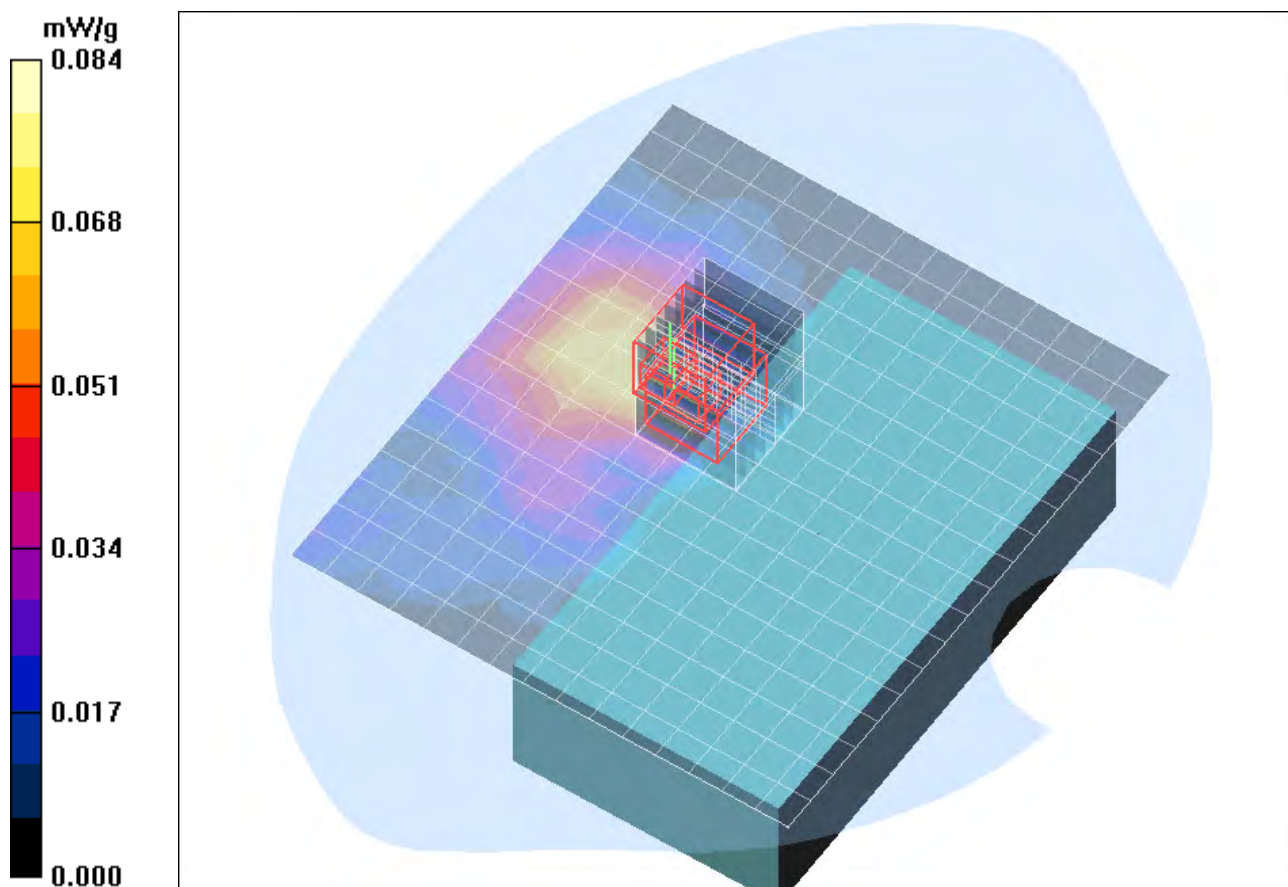

Fig. 79: SAR distribution for IEEE 802.11 a, channel 124, body worn configuration, display towards the phantom, 15 mm distance (May 18, 2010; Ambient Temperature: 21.9° C; Liquid Temperature: 21.3° C).

Test Laboratory: IMST GmbH, DASY Blue (I); File Name: [Elf_bwhm_ch136_15mm_dspl_up.da4](#)

DUT: Datalogic; Type: Elf 701-701; Serial: D10P00071

Program Name: Body Worn

Communication System: 5 GHz ; Frequency: 5680 MHz; Duty Cycle: 1:1

Medium parameters used: $f = 5680$ MHz; $\sigma = 6.06$ mho/m; $\epsilon_r = 47$; $\rho = 1000$ kg/m³

Phantom section: Flat Section

DASY4 Configuration:

- Probe: EX3DV4 - SN3536; ConvF(4.22, 4.22, 4.22); Calibrated: 18.09.2009

- Sensor-Surface: 2mm (Mechanical Surface Detection)

- Electronics: DAE3 Sn335; Calibrated: 10.02.2010

- Phantom: SAM Glycol 1176; Type: Speag; Serial: 1176

- Measurement SW: DASY4, V4.7 Build 80; Postprocessing SW: SEMCAD, V1.8 Build 186

d=10mm, Pin=250mW/Area Scan (16x18x1): Measurement grid: dx=10mm, dy=10mm

Maximum value of SAR (measured) = 0.070 mW/g

d=10mm, Pin=250mW/Zoom Scan (8x8x8)/Cube 0: Measurement grid: dx=4.3mm, dy=4.3mm, dz=3mm

Reference Value = 2.53 V/m; Power Drift = -0.010 dB

Peak SAR (extrapolated) = 0.235 W/kg

SAR(1 g) = 0.028 mW/g; SAR(10 g) = 0.00918 mW/g

Maximum value of SAR (measured) = 0.061 mW/g

d=10mm, Pin=250mW/Zoom Scan (8x8x8)/Cube 1: Measurement grid: dx=4.3mm, dy=4.3mm, dz=3mm

Reference Value = 2.53 V/m; Power Drift = -0.010 dB

Peak SAR (extrapolated) = 0.266 W/kg

SAR(1 g) = 0.035 mW/g; SAR(10 g) = 0.014 mW/g

Maximum value of SAR (measured) = 0.076 mW/g

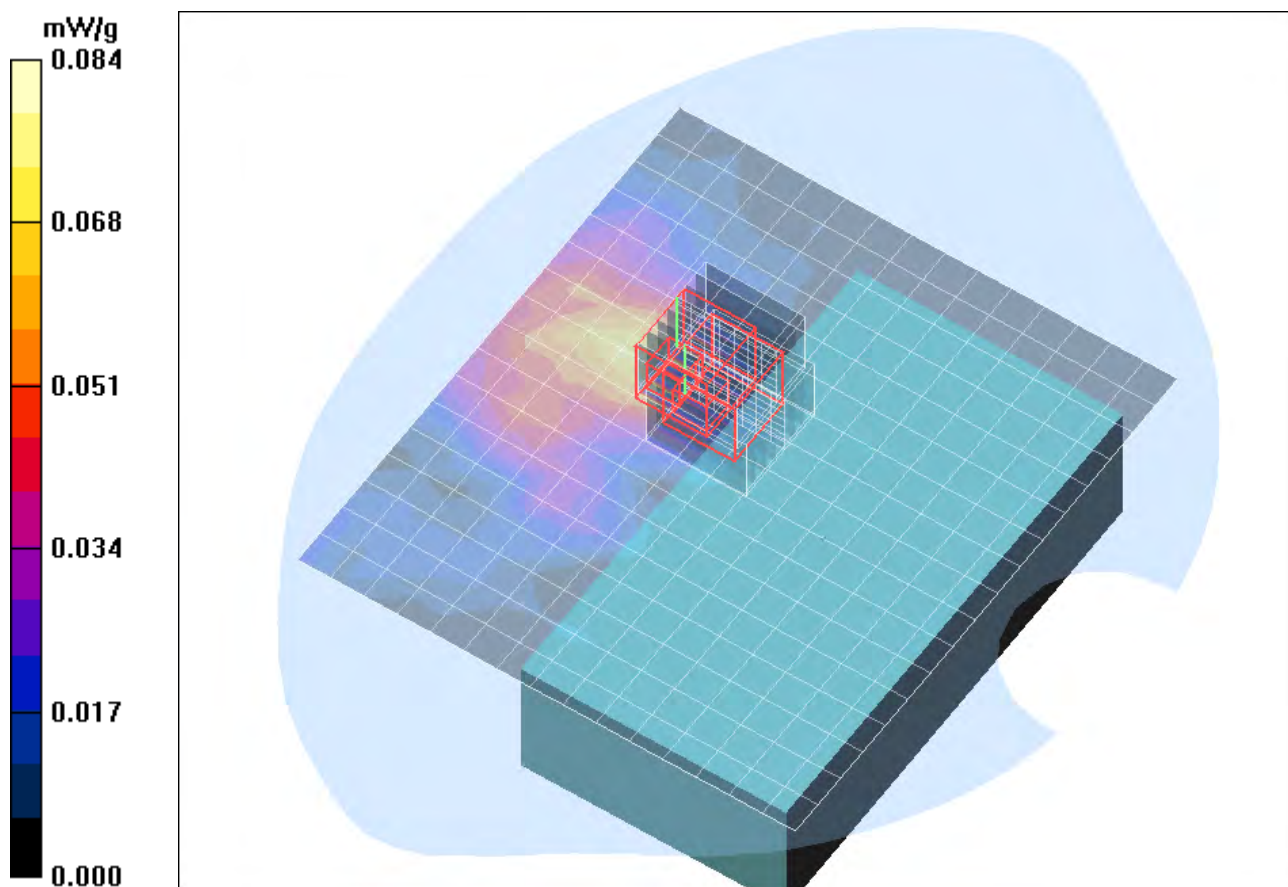

Fig. 80: SAR distribution for IEEE 802.11 a, channel 136, body worn configuration, display towards the phantom, 15 mm distance (May 18, 2010; Ambient Temperature: 21.9° C; Liquid Temperature: 21.3° C).

Test Laboratory: IMST GmbH, DASY Blue (I); File Name: [Elf_bwhm_ch104_15mm_dspl_down.da4](#)

DUT: Datalogic; Type: Elf 701-701; Serial: D10P00071

Program Name: Body Worn

Communication System: 5 GHz ; Frequency: 5520 MHz; Duty Cycle: 1:1

Medium parameters used: $f = 5520$ MHz; $\sigma = 5.91$ mho/m; $\epsilon_r = 47.2$; $\rho = 1000$ kg/m³

Phantom section: Flat Section

DASY4 Configuration:

- Probe: EX3DV4 - SN3536; ConvF(4.22, 4.22, 4.22); Calibrated: 18.09.2009

- Sensor-Surface: 2mm (Mechanical Surface Detection)

- Electronics: DAE3 Sn335; Calibrated: 10.02.2010

- Phantom: SAM Glycol 1176; Type: Speag; Serial: 1176

- Measurement SW: DASY4, V4.7 Build 80; Postprocessing SW: SEMCAD, V1.8 Build 186

d=10mm, Pin=250mW/Area Scan (15x18x1): Measurement grid: dx=10mm, dy=10mm

Maximum value of SAR (measured) = 0.082 mW/g

d=10mm, Pin=250mW/Zoom Scan (8x8x8)/Cube 0: Measurement grid: dx=4.3mm, dy=4.3mm, dz=3mm

Reference Value = 1.90 V/m; Power Drift = -0.046 dB

Peak SAR (extrapolated) = 0.339 W/kg

SAR(1 g) = 0.043 mW/g; SAR(10 g) = 0.016 mW/g

Maximum value of SAR (measured) = 0.092 mW/g

d=10mm, Pin=250mW/Zoom Scan (8x8x8)/Cube 1: Measurement grid: dx=4.3mm, dy=4.3mm, dz=3mm

Reference Value = 1.90 V/m; Power Drift = -0.046 dB

Peak SAR (extrapolated) = 0.266 W/kg

SAR(1 g) = 0.030 mW/g; SAR(10 g) = 0.00986 mW/g

Maximum value of SAR (measured) = 0.057 mW/g

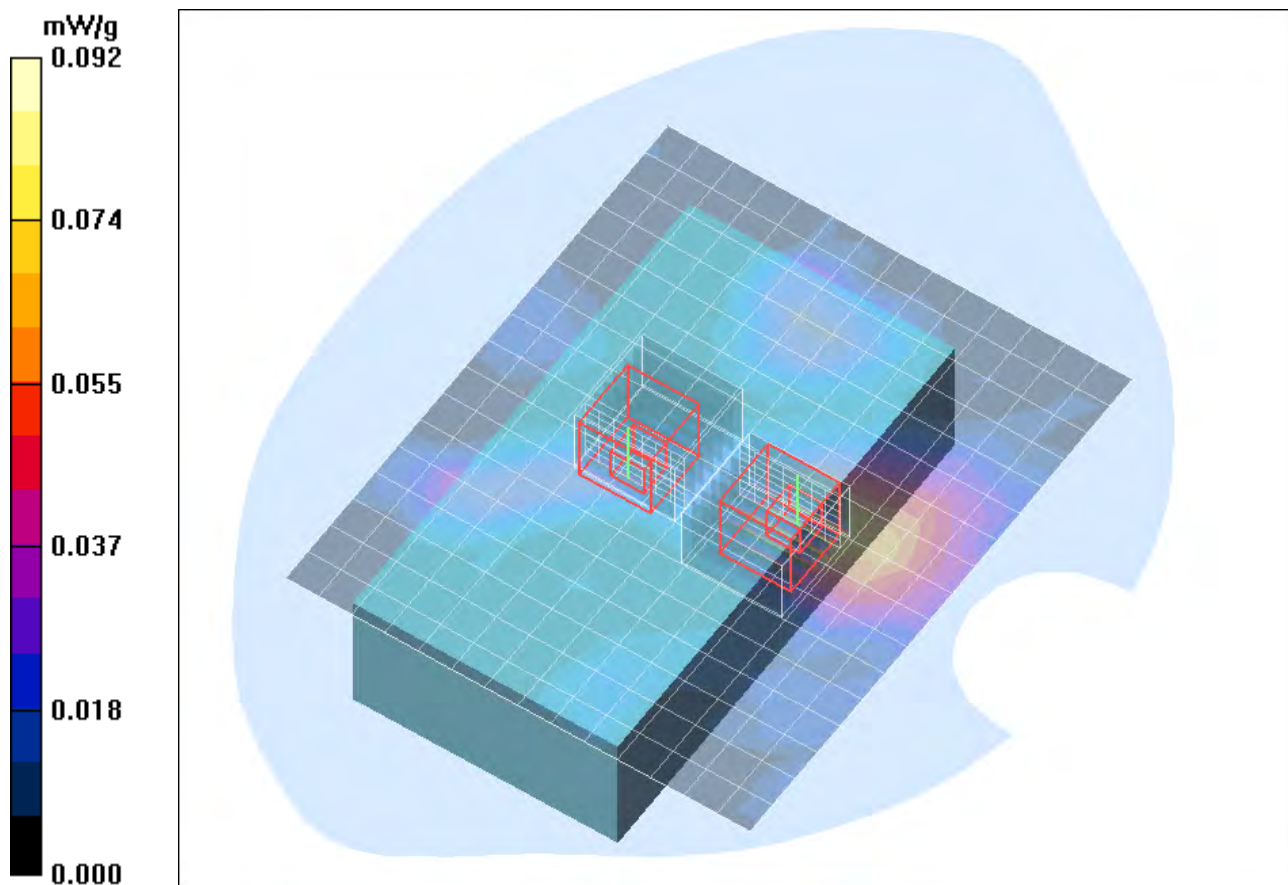

Fig. 81: SAR distribution for IEEE 802.11 a, channel 104, body worn configuration, display towards the ground, 15 mm distance (May 18, 2010; Ambient Temperature: 21.9° C; Liquid Temperature: 21.3° C).

Test Laboratory: IMST GmbH, DASY Blue (I); File Name: [Elf_bwhm_ch116_15mm_dspl_down.da4](#)

DUT: Datalogic; Type: Elf 701-701; Serial: D10P00071

Program Name: Body Worn

Communication System: 5 GHz ; Frequency: 5580 MHz; Duty Cycle: 1:1

Medium parameters used: $f = 5580$ MHz; $\sigma = 5.95$ mho/m; $\epsilon_r = 47.1$; $\rho = 1000$ kg/m³

Phantom section: Flat Section

DASY4 Configuration:

- Probe: EX3DV4 - SN3536; ConvF(4.22, 4.22, 4.22); Calibrated: 18.09.2009

- Sensor-Surface: 2mm (Mechanical Surface Detection)

- Electronics: DAE3 Sn335; Calibrated: 10.02.2010

- Phantom: SAM Glycol 1176; Type: Speag; Serial: 1176

- Measurement SW: DASY4, V4.7 Build 80; Postprocessing SW: SEMCAD, V1.8 Build 186

d=10mm, Pin=250mW/Area Scan (15x18x1): Measurement grid: dx=10mm, dy=10mm

Maximum value of SAR (measured) = 0.102 mW/g

d=10mm, Pin=250mW/Zoom Scan (8x8x8)/Cube 0: Measurement grid: dx=4.3mm, dy=4.3mm, dz=3mm

Reference Value = 1.91 V/m; Power Drift = -0.196 dB

Peak SAR (extrapolated) = 0.294 W/kg

SAR(1 g) = 0.048 mW/g; SAR(10 g) = 0.019 mW/g

Maximum value of SAR (measured) = 0.105 mW/g

d=10mm, Pin=250mW/Zoom Scan (8x8x8)/Cube 1: Measurement grid: dx=4.3mm, dy=4.3mm, dz=3mm

Reference Value = 1.91 V/m; Power Drift = -0.196 dB

Peak SAR (extrapolated) = 0.249 W/kg

SAR(1 g) = 0.029 mW/g; SAR(10 g) = 0.011 mW/g

Maximum value of SAR (measured) = 0.058 mW/g

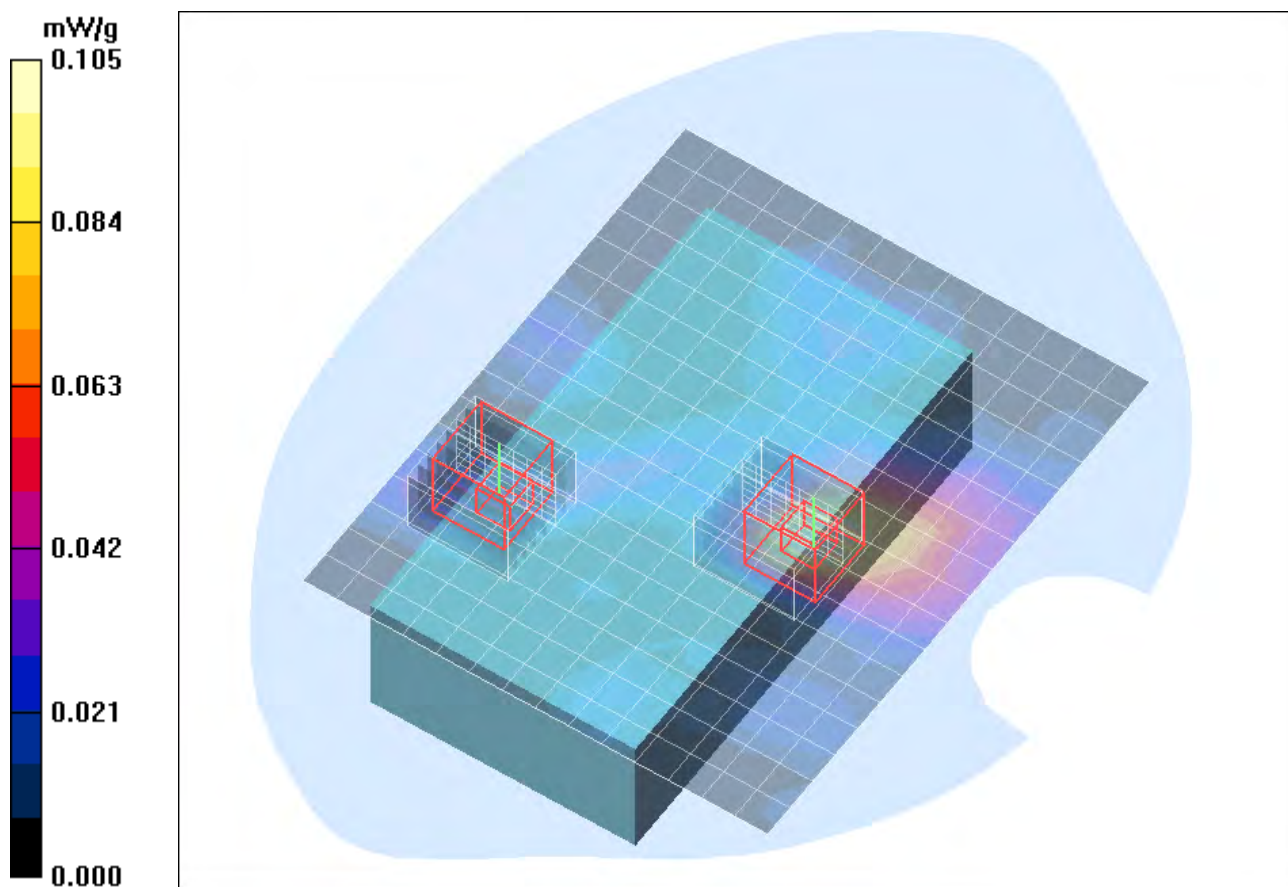

Fig. 82: SAR distribution for IEEE 802.11 a, channel 116, body worn configuration, display towards the ground, 15 mm distance (May 18, 2010; Ambient Temperature: 21.9° C; Liquid Temperature: 21.3° C).

Test Laboratory: IMST GmbH, DASY Blue (I); File Name: [Elf_bwhm_ch124_15mm_dspl_down.da4](#)

DUT: Datalogic; Type: Elf 701-701; Serial: D10P00071

Program Name: Body Worn

Communication System: 5 GHz ; Frequency: 5620 MHz; Duty Cycle: 1:1

Medium parameters used: $f = 5620$ MHz; $\sigma = 5.96$ mho/m; $\epsilon_r = 47$; $\rho = 1000$ kg/m³

Phantom section: Flat Section

DASY4 Configuration:

- Probe: EX3DV4 - SN3536; ConvF(4.22, 4.22, 4.22); Calibrated: 18.09.2009

- Sensor-Surface: 2mm (Mechanical Surface Detection)

- Electronics: DAE3 Sn335; Calibrated: 10.02.2010

- Phantom: SAM Glycol 1176; Type: Speag; Serial: 1176

- Measurement SW: DASY4, V4.7 Build 80; Postprocessing SW: SEMCAD, V1.8 Build 186

d=10mm, Pin=250mW/Area Scan (15x18x1): Measurement grid: dx=10mm, dy=10mm

Maximum value of SAR (measured) = 0.105 mW/g

d=10mm, Pin=250mW/Zoom Scan (8x8x8)/Cube 0: Measurement grid: dx=4.3mm, dy=4.3mm, dz=3mm

Reference Value = 1.65 V/m; Power Drift = -0.126 dB

Peak SAR (extrapolated) = 0.291 W/kg

SAR(1 g) = 0.050 mW/g; SAR(10 g) = 0.020 mW/g

Maximum value of SAR (measured) = 0.110 mW/g

d=10mm, Pin=250mW/Zoom Scan (8x8x8)/Cube 1: Measurement grid: dx=4.3mm, dy=4.3mm, dz=3mm

Reference Value = 1.65 V/m; Power Drift = -0.126 dB

Peak SAR (extrapolated) = 0.207 W/kg

SAR(1 g) = 0.027 mW/g; SAR(10 g) = 0.010 mW/g

Maximum value of SAR (measured) = 0.058 mW/g

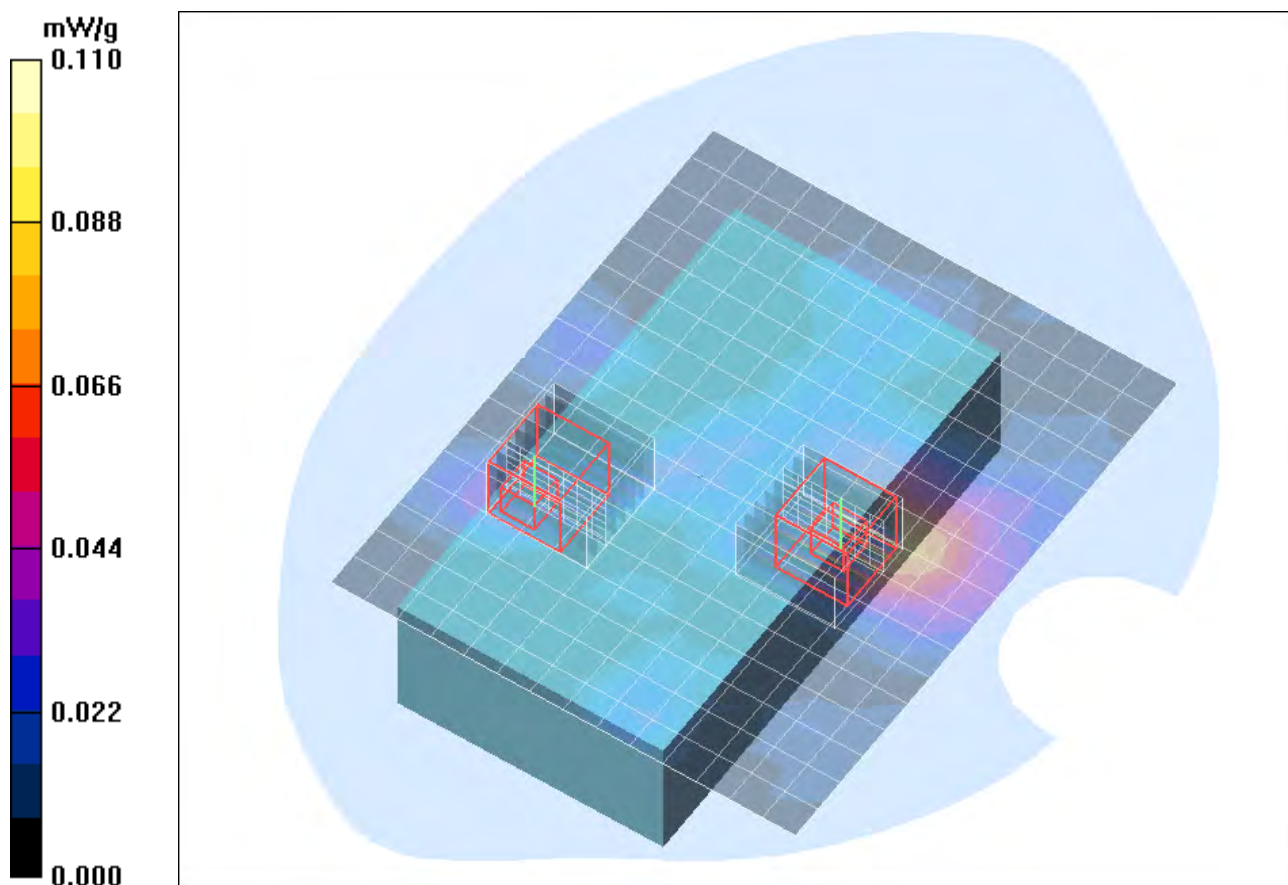

Fig. 83: SAR distribution for IEEE 802.11 a, channel 124, body worn configuration, display towards the ground, 15 mm distance (May 18, 2010; Ambient Temperature: 21.9° C; Liquid Temperature: 21.3° C).

Test Laboratory: IMST GmbH, DASY Blue (I); File Name: [Elf_bwhm_ch136_15mm_dspl_down.da4](#)

DUT: Datalogic; Type: Elf 701-701; Serial: D10P00071

Program Name: Body Worn

Communication System: 5 GHz ; Frequency: 5680 MHz; Duty Cycle: 1:1

Medium parameters used: $f = 5680$ MHz; $\sigma = 6.06$ mho/m; $\epsilon_r = 47$; $\rho = 1000$ kg/m³

Phantom section: Flat Section

DASY4 Configuration:

- Probe: EX3DV4 - SN3536; ConvF(4.22, 4.22, 4.22); Calibrated: 18.09.2009

- Sensor-Surface: 2mm (Mechanical Surface Detection)

- Electronics: DAE3 Sn335; Calibrated: 10.02.2010

- Phantom: SAM Glycol 1176; Type: Speag; Serial: 1176

- Measurement SW: DASY4, V4.7 Build 80; Postprocessing SW: SEMCAD, V1.8 Build 186

d=10mm, Pin=250mW/Area Scan (16x18x1): Measurement grid: dx=10mm, dy=10mm

Maximum value of SAR (measured) = 0.085 mW/g

d=10mm, Pin=250mW/Zoom Scan (8x8x8)/Cube 0: Measurement grid: dx=4.3mm, dy=4.3mm, dz=3mm

Reference Value = 1.89 V/m; Power Drift = 0.128 dB

Peak SAR (extrapolated) = 0.216 W/kg

SAR(1 g) = 0.042 mW/g; SAR(10 g) = 0.017 mW/g

Maximum value of SAR (measured) = 0.091 mW/g

d=10mm, Pin=250mW/Zoom Scan (8x8x8)/Cube 1: Measurement grid: dx=4.3mm, dy=4.3mm, dz=3mm

Reference Value = 1.89 V/m; Power Drift = 0.128 dB

Peak SAR (extrapolated) = 0.273 W/kg

SAR(1 g) = 0.031 mW/g; SAR(10 g) = 0.012 mW/g

Maximum value of SAR (measured) = 0.057 mW/g

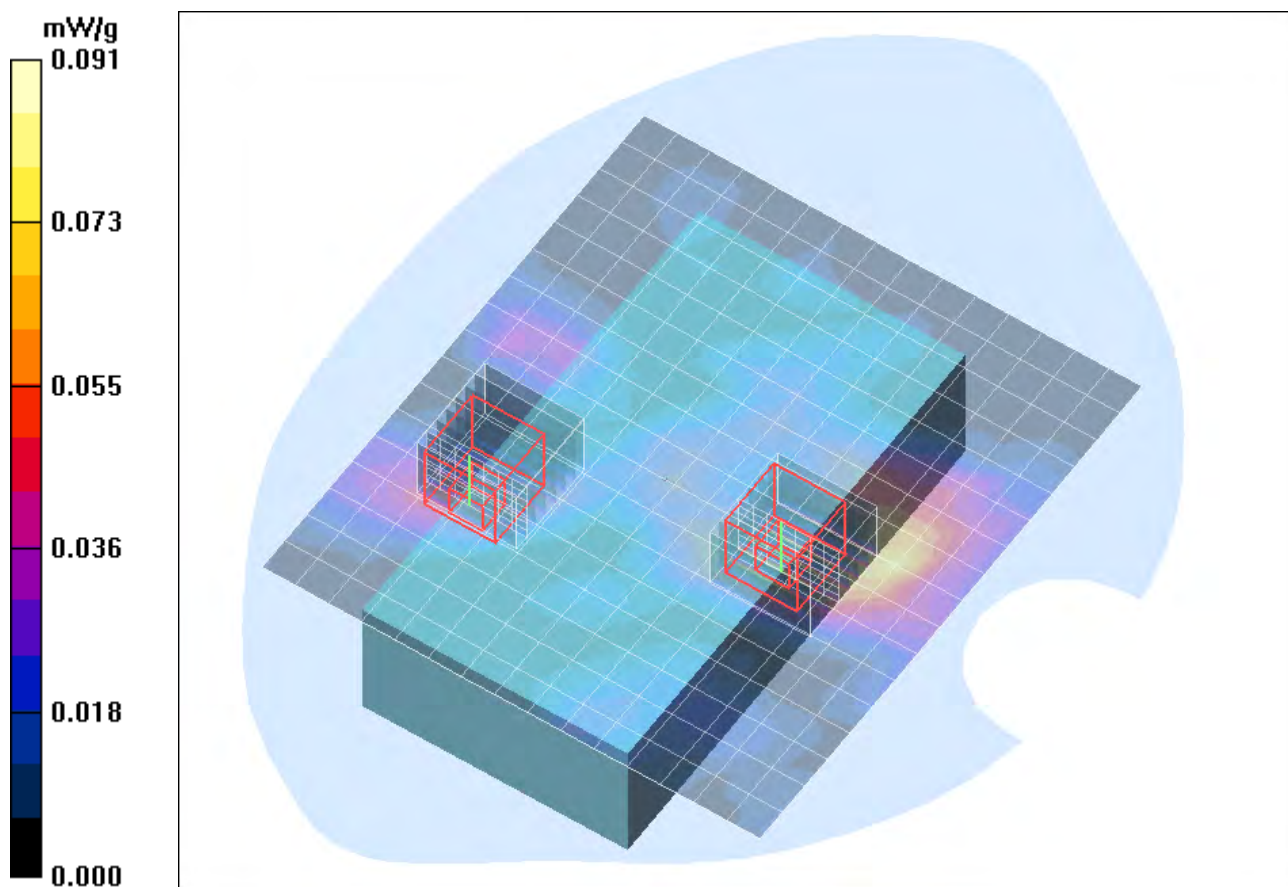

Fig. 84: SAR distribution for IEEE 802.11 a, channel 136, body worn configuration, display towards the ground, 15 mm distance (May 18, 2010; Ambient Temperature: 21.9° C; Liquid Temperature: 21.3° C).

17 SAR Distribution Plots, IEEE 802.11 a Head (5800 MHz Range)

Test Laboratory: IMST GmbH, DASY Blue (I); File Name: [Elf bwlm 1 CH149.da4](#)

DUT: Datalogic; Type: Elf 701-701; Serial: D10P00071

Program Name: Cheek Left

Communication System: 5 GHz ; Frequency: 5745 MHz; Duty Cycle: 1:1

Medium parameters used: $f = 5745$ MHz; $\sigma = 5.48$ mho/m; $\epsilon_r = 36$; $\rho = 1000$ kg/m³

Phantom section: Left Section

DASY4 Configuration:

- Probe: EX3DV4 - SN3536; ConvF(4.63, 4.63, 4.63); Calibrated: 18.09.2009

- Sensor-Surface: 4mm (Mechanical Surface Detection)

- Electronics: DAE3 Sn335; Calibrated: 10.02.2010

- Phantom: SAM Glycol 1176; Type: Speag; Serial: 1176

- Measurement SW: DASY4, V4.7 Build 80; Postprocessing SW: SEMCAD, V1.8 Build 186

Cheek Left/Area Scan (9x14x1): Measurement grid: dx=15mm, dy=15mm

Maximum value of SAR (measured) = 0.118 mW/g

Cheek Left/Zoom Scan (7x7x7)/Cube 0: Measurement grid: dx=5mm, dy=5mm, dz=5mm

Reference Value = 4.81 V/m; Power Drift = 0.138 dB

Peak SAR (extrapolated) = 0.696 W/kg

SAR(1 g) = 0.137 mW/g; SAR(10 g) = 0.045 mW/g

Maximum value of SAR (measured) = 0.116 mW/g

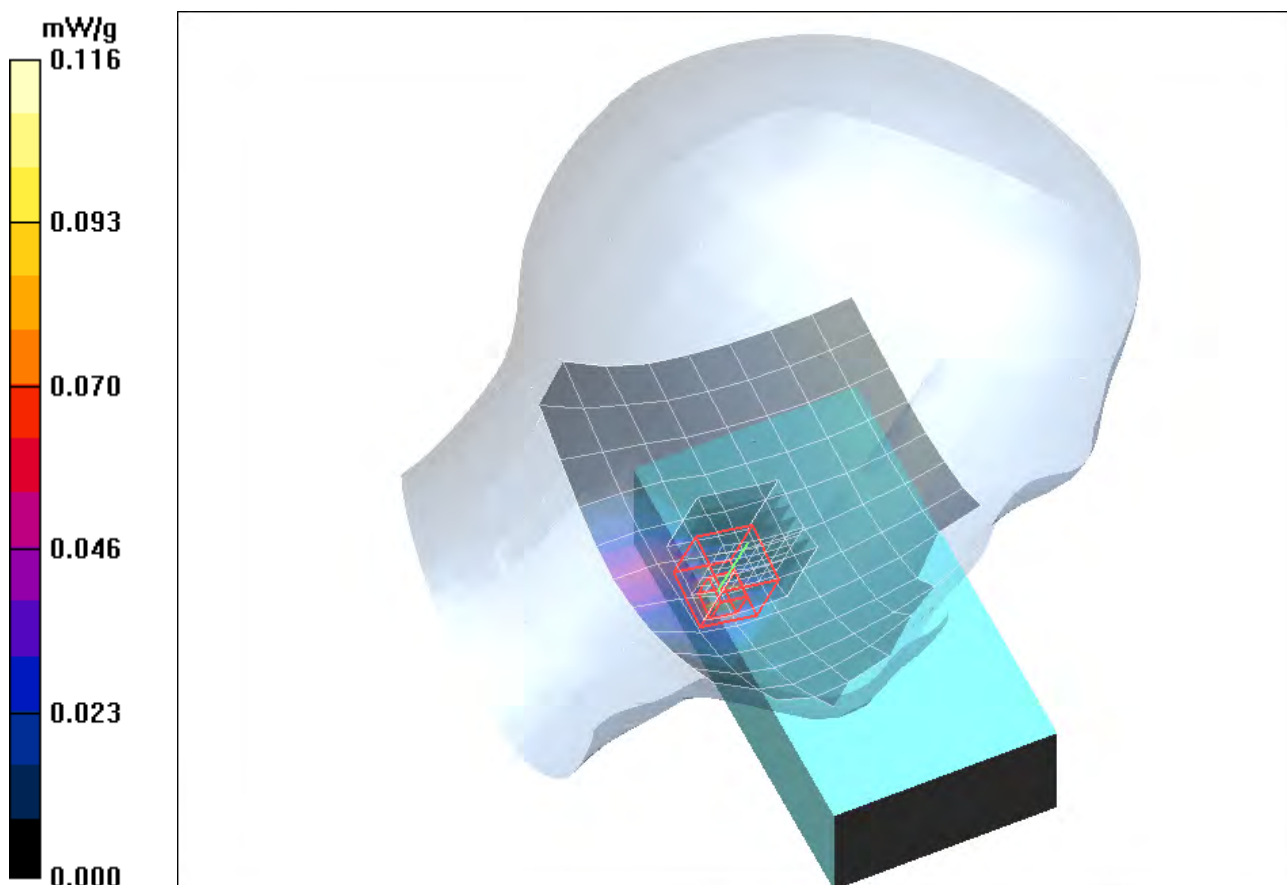

Fig. 85: SAR distribution for IEEE 802.11 a, channel 149, cheek position, left side of head (May 21, 2010; Ambient Temperature: 21.9° C; Liquid Temperature: 21.3° C).

Test Laboratory: IMST GmbH, DASY Blue (I); File Name: [Elf bwlm 1 CH161.da4](#)

DUT: Datalogic; Type: Elf 701-701; Serial: D10P00071

Program Name: Cheek Left

Communication System: 5 GHz ; Frequency: 5805 MHz; Duty Cycle: 1:1

Medium parameters used: $f = 5805$ MHz; $\sigma = 5.49$ mho/m; $\epsilon_r = 35.8$; $\rho = 1000$ kg/m³

Phantom section: Left Section

DASY4 Configuration:

- Probe: EX3DV4 - SN3536; ConvF(4.63, 4.63, 4.63); Calibrated: 18.09.2009
- Sensor-Surface: 4mm (Mechanical Surface Detection)
- Electronics: DAE3 Sn335; Calibrated: 10.02.2010
- Phantom: SAM Glycol 1176; Type: Speag; Serial: 1176
- Measurement SW: DASY4, V4.7 Build 80; Postprocessing SW: SEMCAD, V1.8 Build 186

Cheek Left/Area Scan (9x14x1): Measurement grid: dx=15mm, dy=15mm

Maximum value of SAR (measured) = 0.120 mW/g

Cheek Left/Zoom Scan (7x7x7)/Cube 0: Measurement grid: dx=5mm, dy=5mm, dz=5mm

Reference Value = 4.83 V/m; Power Drift = 0.187 dB

Peak SAR (extrapolated) = 0.695 W/kg

SAR(1 g) = 0.137 mW/g; SAR(10 g) = 0.045 mW/g

Maximum value of SAR (measured) = 0.122 mW/g

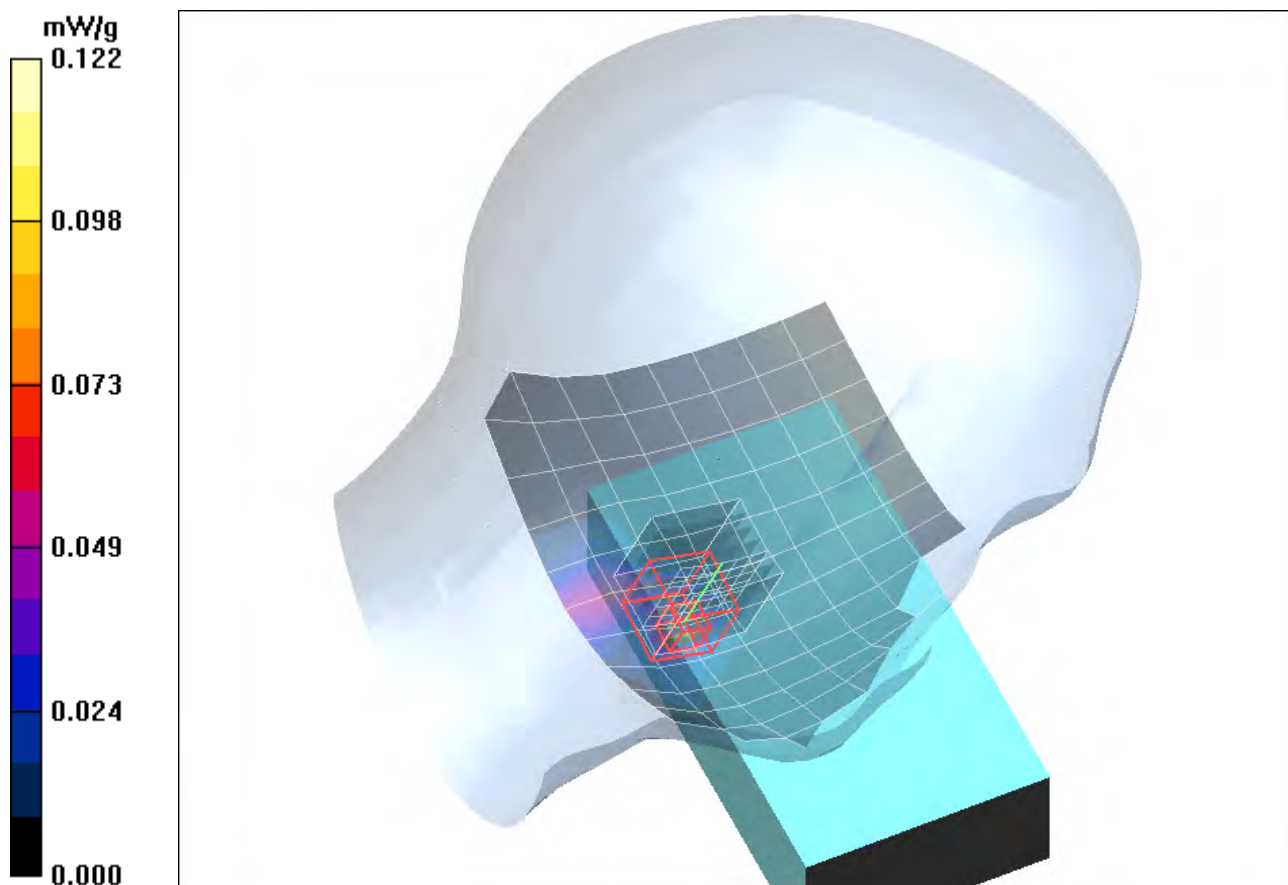

Fig. 86: SAR distribution for IEEE 802.11 a, channel 161, cheek position, left side of head (May 21, 2010; Ambient Temperature: 21.9° C; Liquid Temperature: 21.3° C).

Test Laboratory: IMST GmbH, DASY Blue (I); File Name: [Elf_bwlm_2_CH161.da4](#)

DUT: Datalogic; Type: Elf 701-701; Serial: D10P00071

Program Name: Tilted Left

Communication System: 5 GHz ; Frequency: 5805 MHz; Duty Cycle: 1:1

Medium parameters used: $f = 5805$ MHz; $\sigma = 5.49$ mho/m; $\epsilon_r = 35.8$; $\rho = 1000$ kg/m³

Phantom section: Left Section

DASY4 Configuration:

- Probe: EX3DV4 - SN3536; ConvF(4.63, 4.63, 4.63); Calibrated: 18.09.2009
- Sensor-Surface: 4mm (Mechanical Surface Detection)
- Electronics: DAE3 Sn335; Calibrated: 10.02.2010
- Phantom: SAM Glycol 1176; Type: Speag; Serial: 1176
- Measurement SW: DASY4, V4.7 Build 80; Postprocessing SW: SEMCAD, V1.8 Build 186

Tilted Left/Area Scan (10x14x1): Measurement grid: dx=15mm, dy=15mm

Maximum value of SAR (measured) = 0.028 mW/g

Tilted Left/Zoom Scan (7x7x7)/Cube 0: Measurement grid: dx=5mm, dy=5mm, dz=5mm

Reference Value = 2.01 V/m; Power Drift = 0.117 dB

Peak SAR (extrapolated) = 0.166 W/kg

SAR(1 g) = 0.034 mW/g; SAR(10 g) = 0.012 mW/g

Maximum value of SAR (measured) = 0.026 mW/g

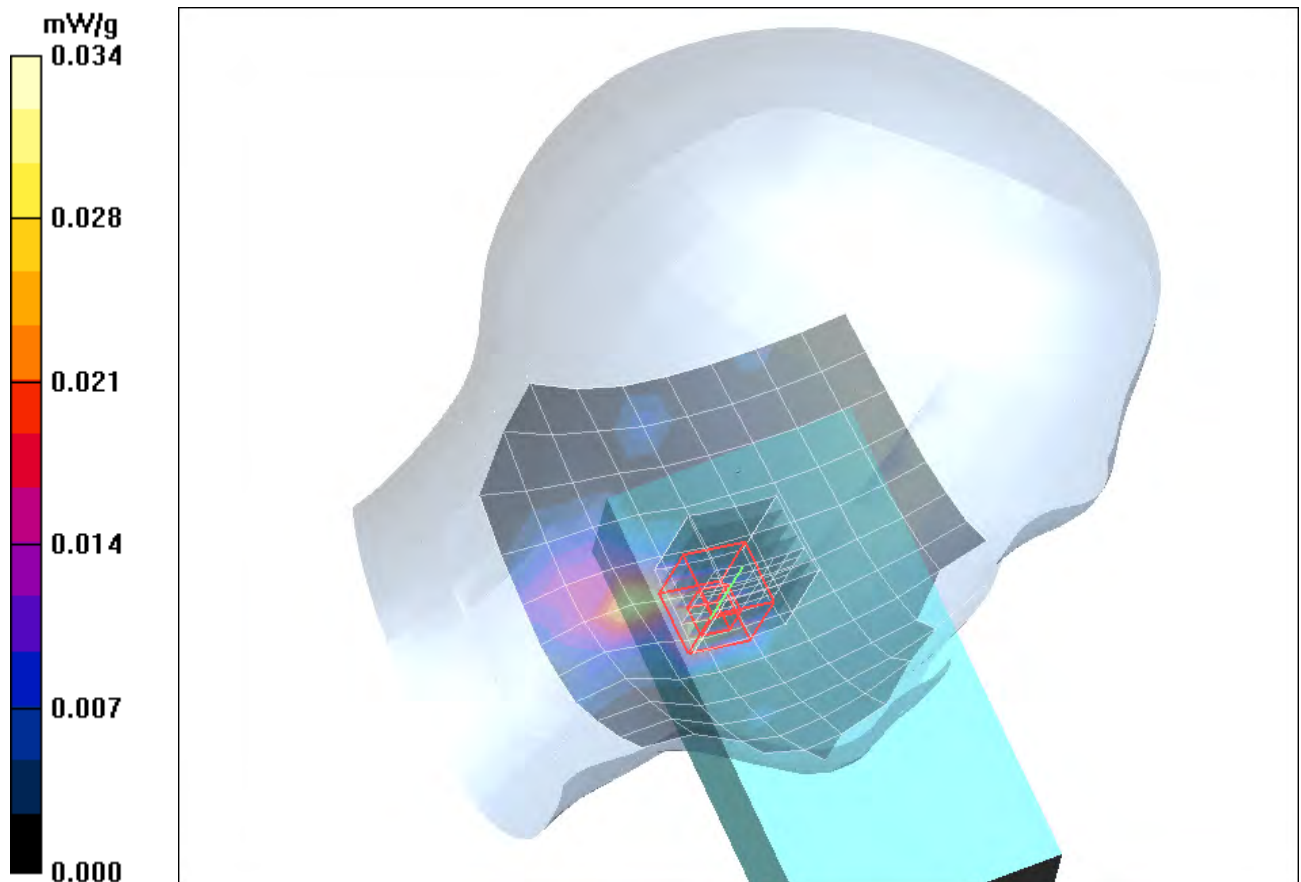

Fig. 87: SAR distribution for IEEE 802.11 a, channel 161, tilted position, left side of head (May 21, 2010; Ambient Temperature: 21.9° C; Liquid Temperature: 21.3° C).

Test Laboratory: IMST GmbH, DASY Blue (I); File Name: [Elf_bwrm_1_CH149.da4](#)

DUT: Datalogic; Type: Elf 701-701; Serial: D10P00071

Program Name: Cheek Right

Communication System: 5 GHz ; Frequency: 5745 MHz; Duty Cycle: 1:1

Medium parameters used: $f = 5745$ MHz; $\sigma = 5.48$ mho/m; $\epsilon_r = 36$; $\rho = 1000$ kg/m³

Phantom section: Right Section

DASY4 Configuration:

- Probe: EX3DV4 - SN3536; ConvF(4.63, 4.63, 4.63); Calibrated: 18.09.2009
- Sensor-Surface: 4mm (Mechanical Surface Detection)
- Electronics: DAE3 Sn335; Calibrated: 10.02.2010
- Phantom: SAM Glycol 1176; Type: Speag; Serial: 1176
- Measurement SW: DASY4, V4.7 Build 80; Postprocessing SW: SEMCAD, V1.8 Build 186

Cheek Right/Area Scan (10x14x1): Measurement grid: dx=15mm, dy=15mm

Maximum value of SAR (measured) = 0.071 mW/g

Cheek Right/Zoom Scan (7x7x7)/Cube 0: Measurement grid: dx=5mm, dy=5mm, dz=5mm

Reference Value = 3.79 V/m; Power Drift = -0.061 dB

Peak SAR (extrapolated) = 0.535 W/kg

SAR(1 g) = 0.111 mW/g; SAR(10 g) = 0.044 mW/g

Maximum value of SAR (measured) = 0.086 mW/g

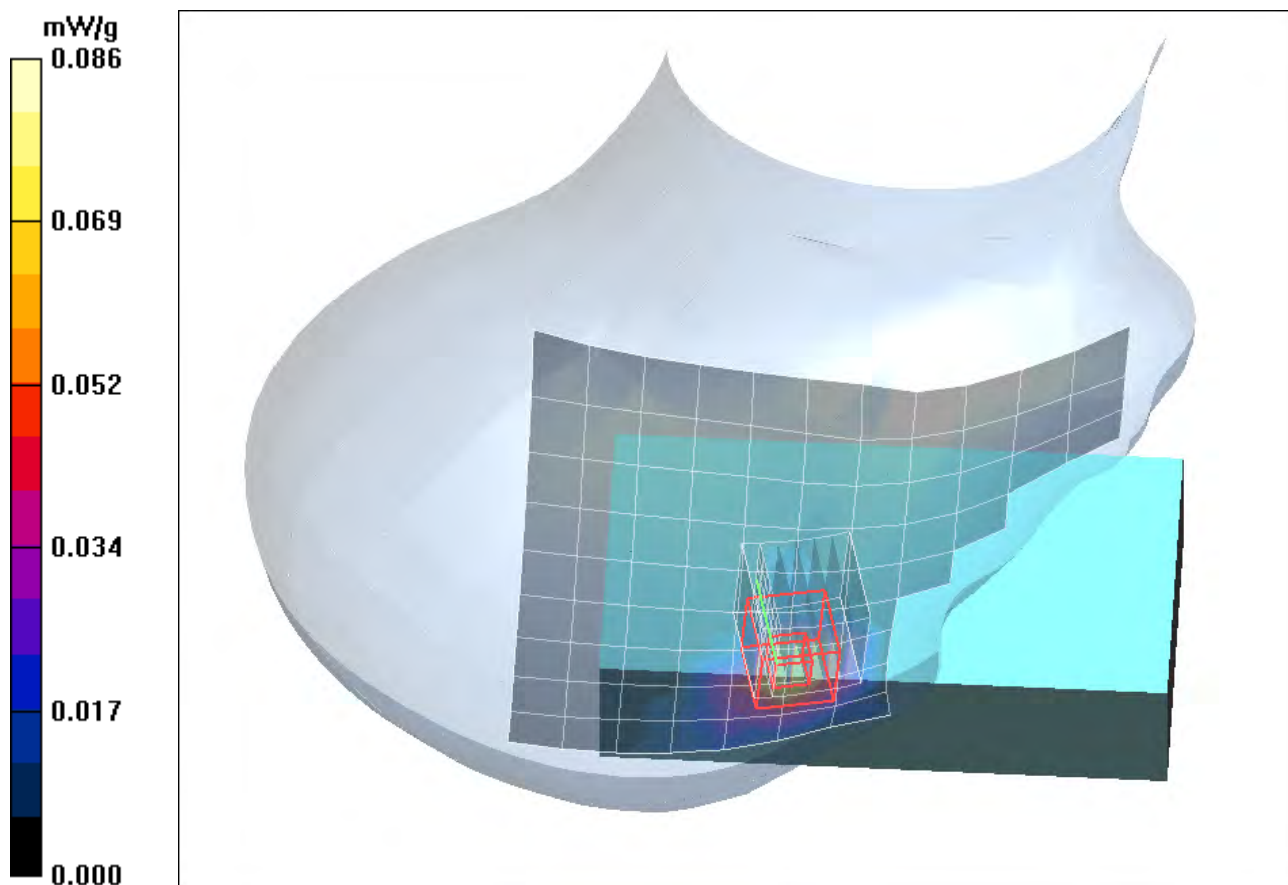

Fig. 88: SAR distribution for IEEE 802.11 a, channel 149, cheek position, right side of head (May 21, 2010; Ambient Temperature: 21.9° C; Liquid Temperature: 21.3° C).

Test Laboratory: IMST GmbH, DASY Blue (I); File Name: [Elf_bwrm_1_CH161.da4](#)

DUT: Datalogic; Type: Elf 701-701; Serial: D10P00071

Program Name: Cheek Right

Communication System: 5 GHz ; Frequency: 5805 MHz; Duty Cycle: 1:1

Medium parameters used: $f = 5805$ MHz; $\sigma = 5.49$ mho/m; $\epsilon_r = 35.8$; $\rho = 1000$ kg/m³

Phantom section: Right Section

DASY4 Configuration:

- Probe: EX3DV4 - SN3536; ConvF(4.63, 4.63, 4.63); Calibrated: 18.09.2009
- Sensor-Surface: 4mm (Mechanical Surface Detection)
- Electronics: DAE3 Sn335; Calibrated: 10.02.2010
- Phantom: SAM Glycol 1176; Type: Speag; Serial: 1176
- Measurement SW: DASY4, V4.7 Build 80; Postprocessing SW: SEMCAD, V1.8 Build 186

Cheek Right/Area Scan (10x14x1): Measurement grid: dx=15mm, dy=15mm

Maximum value of SAR (measured) = 0.084 mW/g

Cheek Right/Zoom Scan (7x7x7)/Cube 0: Measurement grid: dx=5mm, dy=5mm, dz=5mm

Reference Value = 3.84 V/m; Power Drift = 0.005 dB

Peak SAR (extrapolated) = 0.552 W/kg

SAR(1 g) = 0.111 mW/g; SAR(10 g) = 0.040 mW/g

Maximum value of SAR (measured) = 0.093 mW/g

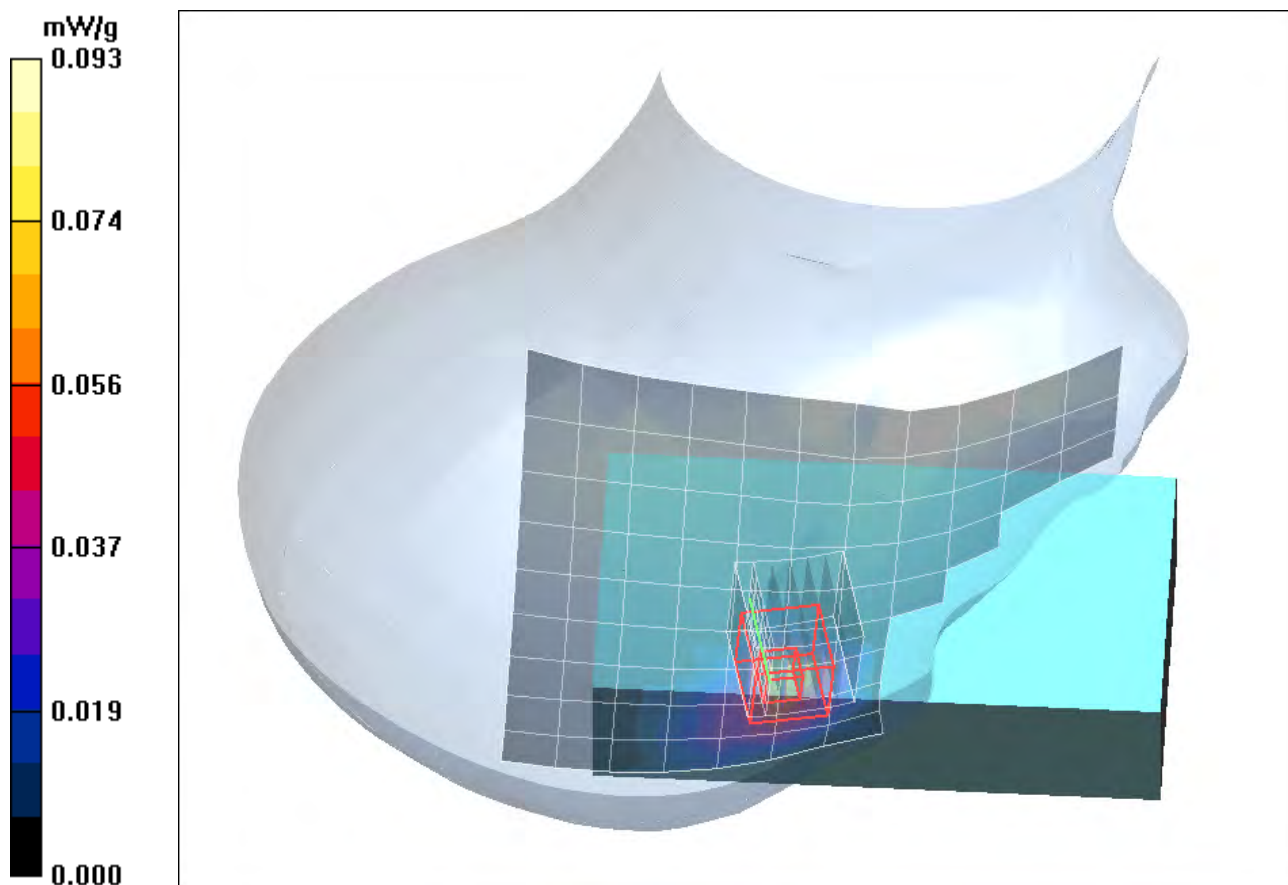

Fig. 89: SAR distribution for IEEE 802.11 a, channel 161, cheek position, right side of head (May 21, 2010; Ambient Temperature: 21.9° C; Liquid Temperature: 21.3° C).

Test Laboratory: IMST GmbH, DASY Blue (I); File Name: [Elf_bwrm_2_CH161.da4](#)

DUT: Datalogic; Type: Elf 701-701; Serial: D10P00071

Program Name: Tilted Right

Communication System: 5 GHz ; Frequency: 5805 MHz; Duty Cycle: 1:1

Medium parameters used: $f = 5805$ MHz; $\sigma = 5.49$ mho/m; $\epsilon_r = 35.8$; $\rho = 1000$ kg/m³

Phantom section: Right Section

DASY4 Configuration:

- Probe: EX3DV4 - SN3536; ConvF(4.63, 4.63, 4.63); Calibrated: 18.09.2009
- Sensor-Surface: 4mm (Mechanical Surface Detection)
- Electronics: DAE3 Sn335; Calibrated: 10.02.2010
- Phantom: SAM Glycol 1176; Type: Speag; Serial: 1176
- Measurement SW: DASY4, V4.7 Build 80; Postprocessing SW: SEMCAD, V1.8 Build 186

Tilted Right/Area Scan (10x14x1): Measurement grid: dx=15mm, dy=15mm

Maximum value of SAR (measured) = 0.023 mW/g

Tilted Right/Zoom Scan (7x7x7)/Cube 0: Measurement grid: dx=5mm, dy=5mm, dz=5mm

Reference Value = 2.23 V/m; Power Drift = -0.056 dB

Peak SAR (extrapolated) = 0.164 W/kg

SAR(1 g) = 0.034 mW/g; SAR(10 g) = 0.011 mW/g

Maximum value of SAR (measured) = 0.028 mW/g

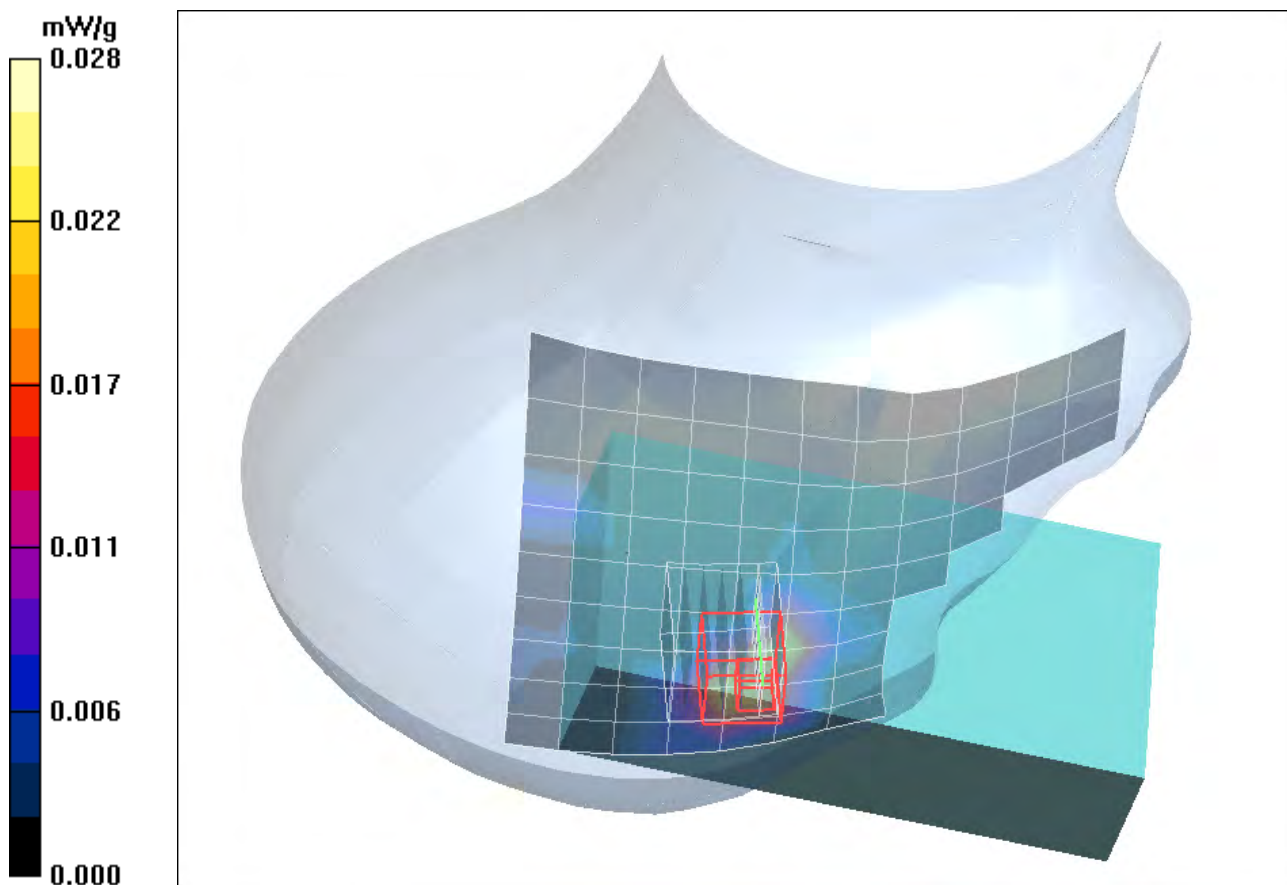

Fig. 90: SAR distribution for IEEE 802.11 a, channel 161, tilted position, right side of head (May 21, 2010; Ambient Temperature: 21.9° C; Liquid Temperature: 21.3° C).

18 SAR Distribution Plots, IEEE 802.11 a Body (5800 MHz Range)

Test Laboratory: IMST GmbH, DASY Blue (I); File Name: [Elf_bwhm_ch149_15mm_dspl_up.da4](#)

DUT: Datalogic; Type: Elf 701-701; Serial: D10P00071
Program Name: Body Worn

Communication System: 5 GHz ; Frequency: 5745 MHz; Duty Cycle: 1:1
Medium parameters used: $f = 5745$ MHz; $\sigma = 6.2$ mho/m; $\epsilon_r = 46.9$; $\rho = 1000$ kg/m³
Phantom section: Flat Section

DASY4 Configuration:

- Probe: EX3DV4 - SN3536; ConvF(4.2, 4.2, 4.2); Calibrated: 18.09.2009
- Sensor-Surface: 2mm (Mechanical Surface Detection)
- Electronics: DAE3 Sn335; Calibrated: 10.02.2010
- Phantom: SAM Glycol 1176; Type: Speag; Serial: 1176
- Measurement SW: DASY4, V4.7 Build 80; Postprocessing SW: SEMCAD, V1.8 Build 186

d=10mm, Pin=250mW/Area Scan (16x19x1): Measurement grid: dx=10mm, dy=10mm

Maximum value of SAR (measured) = 0.086 mW/g

d=10mm, Pin=250mW/Zoom Scan (8x8x8)/Cube 0: Measurement grid: dx=4.3mm, dy=4.3mm, dz=3mm

Reference Value = 2.72 V/m; Power Drift = 0.076 dB

Peak SAR (extrapolated) = 0.246 W/kg

SAR(1 g) = 0.039 mW/g; SAR(10 g) = 0.015 mW/g

Maximum value of SAR (measured) = 0.089 mW/g

d=10mm, Pin=250mW/Zoom Scan (8x8x8)/Cube 1: Measurement grid: dx=4.3mm, dy=4.3mm, dz=3mm

Reference Value = 2.72 V/m; Power Drift = 0.076 dB

Peak SAR (extrapolated) = 0.261 W/kg

SAR(1 g) = 0.039 mW/g; SAR(10 g) = 0.016 mW/g

Maximum value of SAR (measured) = 0.088 mW/g

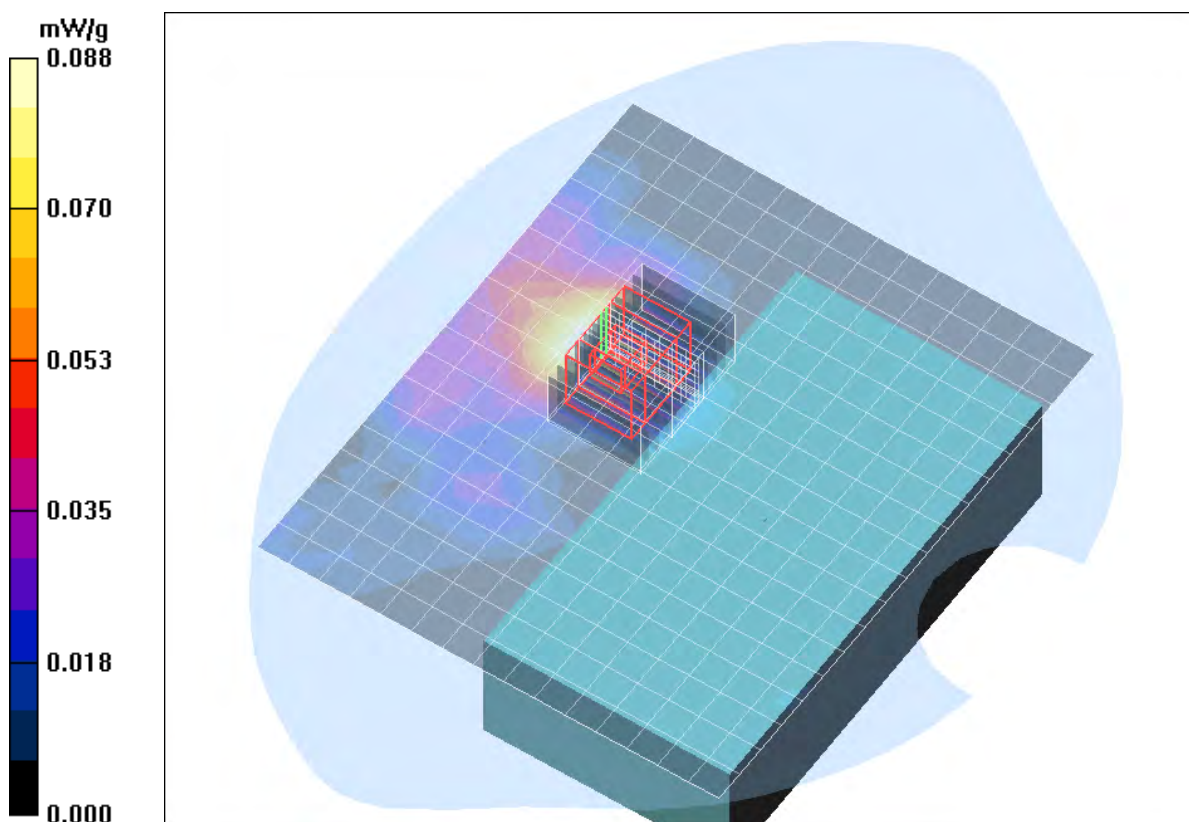

Fig. 91: SAR distribution for IEEE 802.11 a, channel 149, body worn configuration, display towards the phantom, 15 mm distance (May 14, 2010; Ambient Temperature: 21.8° C; Liquid Temperature: 21.2° C).

Test Laboratory: IMST GmbH, DASY Blue (I); File Name: [Elf_bwhm_ch161_15mm_dspl_up.da4](#)

DUT: Datalogic; Type: Elf 701-701; Serial: D10P00071

Program Name: Body Worn

Communication System: 5 GHz ; Frequency: 5805 MHz; Duty Cycle: 1:1

Medium parameters used: $f = 5805$ MHz; $\sigma = 6.27$ mho/m; $\epsilon_r = 46.8$; $\rho = 1000$ kg/m³

Phantom section: Flat Section

DASY4 Configuration:

- Probe: EX3DV4 - SN3536; ConvF(4.2, 4.2, 4.2); Calibrated: 18.09.2009

- Sensor-Surface: 2mm (Mechanical Surface Detection)

- Electronics: DAE3 Sn335; Calibrated: 10.02.2010

- Phantom: SAM Glycol 1176; Type: Speag; Serial: 1176

- Measurement SW: DASY4, V4.7 Build 80; Postprocessing SW: SEMCAD, V1.8 Build 186

d=10mm, Pin=250mW/Area Scan (16x19x1): Measurement grid: dx=10mm, dy=10mm

Maximum value of SAR (measured) = 0.085 mW/g

d=10mm, Pin=250mW/Zoom Scan (8x8x8)/Cube 0: Measurement grid: dx=4.3mm, dy=4.3mm, dz=3mm

Reference Value = 2.78 V/m; Power Drift = 0.091 dB

Peak SAR (extrapolated) = 0.175 W/kg

SAR(1 g) = 0.042 mW/g; SAR(10 g) = 0.018 mW/g

Maximum value of SAR (measured) = 0.094 mW/g

d=10mm, Pin=250mW/Zoom Scan (8x8x8)/Cube 1: Measurement grid: dx=4.3mm, dy=4.3mm, dz=3mm

Reference Value = 2.78 V/m; Power Drift = 0.091 dB

Peak SAR (extrapolated) = 0.369 W/kg

SAR(1 g) = 0.042 mW/g; SAR(10 g) = 0.017 mW/g

Maximum value of SAR (measured) = 0.088 mW/g

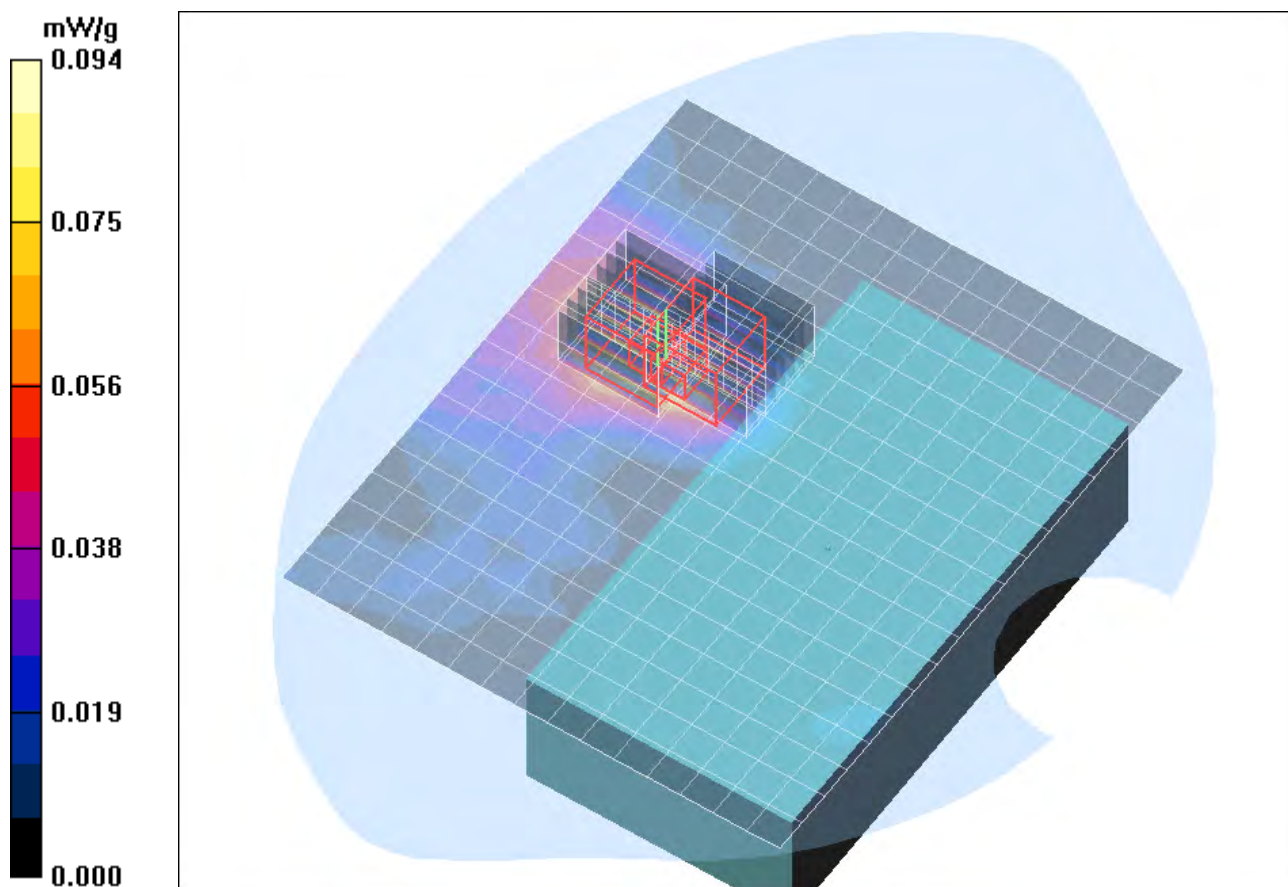

Fig. 92: SAR distribution for IEEE 802.11 a, channel 161, body worn configuration, display towards the phantom, 15 mm distance (May 14, 2010; Ambient Temperature: 21.8° C; Liquid Temperature: 21.2° C).

Test Laboratory: IMST GmbH, DASY Blue (I); File Name: [Elf_bwhm_ch149_15mm_dspl_down.da4](#)

DUT: Datalogic; Type: Elf 701-701; Serial: D10P00071

Program Name: Body Worn

Communication System: 5 GHz ; Frequency: 5745 MHz; Duty Cycle: 1:1

Medium parameters used: $f = 5745$ MHz; $\sigma = 6.2$ mho/m; $\epsilon_r = 46.9$; $\rho = 1000$ kg/m³

Phantom section: Flat Section

DASY4 Configuration:

- Probe: EX3DV4 - SN3536; ConvF(4.2, 4.2, 4.2); Calibrated: 18.09.2009

- Sensor-Surface: 2mm (Mechanical Surface Detection)

- Electronics: DAE3 Sn335; Calibrated: 10.02.2010

- Phantom: SAM Glycol 1176; Type: Speag; Serial: 1176

- Measurement SW: DASY4, V4.7 Build 80; Postprocessing SW: SEMCAD, V1.8 Build 186

d=10mm, Pin=250mW/Area Scan (15x19x1): Measurement grid: dx=10mm, dy=10mm

Maximum value of SAR (measured) = 0.155 mW/g

d=10mm, Pin=250mW/Zoom Scan (8x8x8)/Cube 0: Measurement grid: dx=4.3mm, dy=4.3mm, dz=3mm

Reference Value = 2.20 V/m; Power Drift = -0.058 dB

Peak SAR (extrapolated) = 0.259 W/kg

SAR(1 g) = 0.075 mW/g; SAR(10 g) = 0.027 mW/g

Maximum value of SAR (measured) = 0.150 mW/g

d=10mm, Pin=250mW/Zoom Scan (8x8x8)/Cube 1: Measurement grid: dx=4.3mm, dy=4.3mm, dz=3mm

Reference Value = 2.20 V/m; Power Drift = -0.058 dB

Peak SAR (extrapolated) = 0.225 W/kg

SAR(1 g) = 0.039 mW/g; SAR(10 g) = 0.016 mW/g

Maximum value of SAR (measured) = 0.089 mW/g

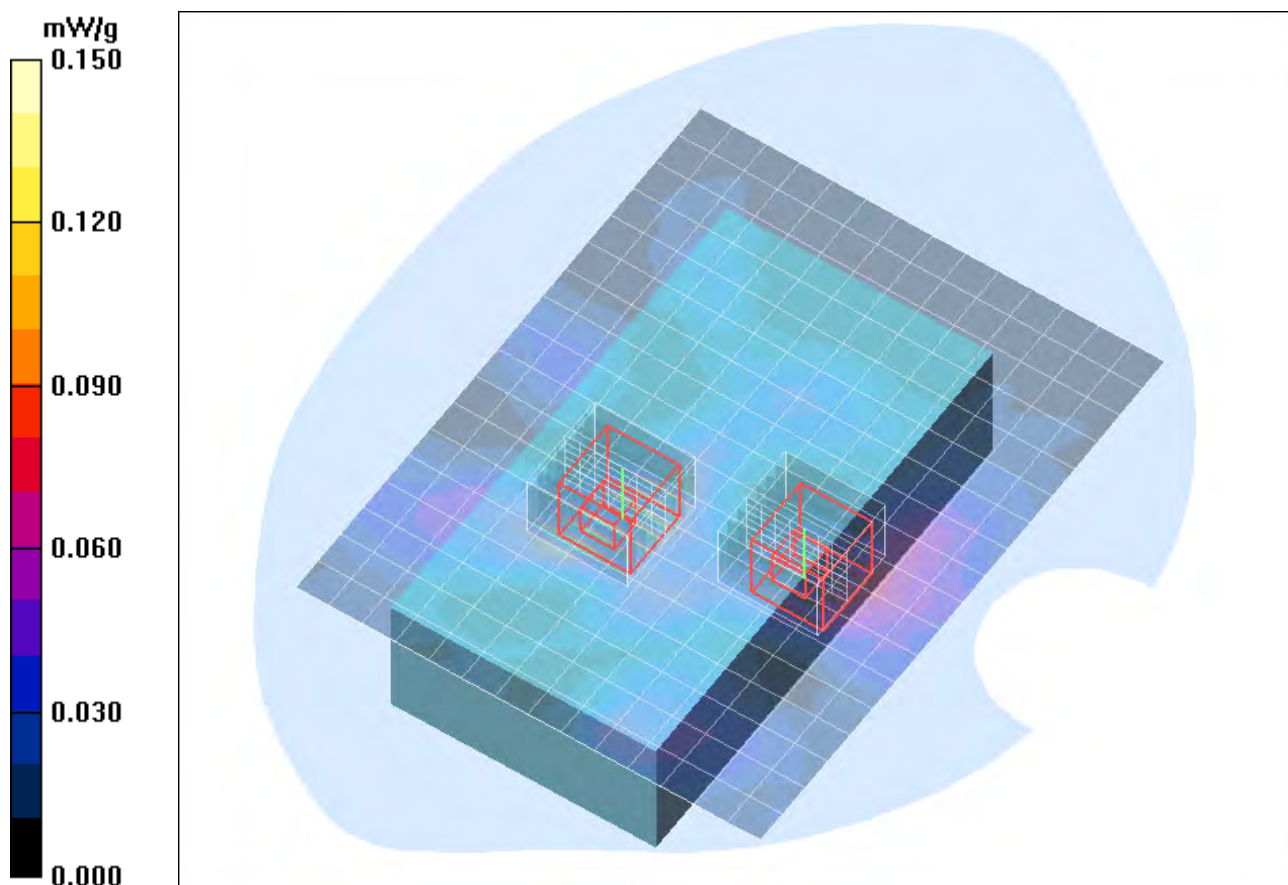

Fig. 93: SAR distribution for IEEE 802.11a, channel 149, body worn configuration, display towards the ground, 15 mm distance (May 14, 2010; Ambient Temperature: 21.8° C; Liquid Temperature: 21.2° C).

Test Laboratory: IMST GmbH, DASY Blue (I); File Name: [Elf_bwhm_ch161_15mm_dspl_down.da4](#)

DUT: Datalogic; Type: Elf 701-701; Serial: D10P00071

Program Name: Body Worn

Communication System: 5 GHz ; Frequency: 5805 MHz; Duty Cycle: 1:1

Medium parameters used: $f = 5805$ MHz; $\sigma = 6.27$ mho/m; $\epsilon_r = 46.8$; $\rho = 1000$ kg/m³

Phantom section: Flat Section

DASY4 Configuration:

- Probe: EX3DV4 - SN3536; ConvF(4.2, 4.2, 4.2); Calibrated: 18.09.2009

- Sensor-Surface: 2mm (Mechanical Surface Detection)

- Electronics: DAE3 Sn335; Calibrated: 10.02.2010

- Phantom: SAM Glycol 1176; Type: Speag; Serial: 1176

- Measurement SW: DASY4, V4.7 Build 80; Postprocessing SW: SEMCAD, V1.8 Build 186

d=10mm, Pin=250mW/Area Scan (15x19x1): Measurement grid: dx=10mm, dy=10mm

Maximum value of SAR (measured) = 0.170 mW/g

d=10mm, Pin=250mW/Zoom Scan (8x8x8)/Cube 0: Measurement grid: dx=4.3mm, dy=4.3mm, dz=3mm

Reference Value = 2.03 V/m; Power Drift = 0.013 dB

Peak SAR (extrapolated) = 0.293 W/kg

SAR(1 g) = 0.091 mW/g; SAR(10 g) = 0.033 mW/g

Maximum value of SAR (measured) = 0.194 mW/g

d=10mm, Pin=250mW/Zoom Scan (8x8x8)/Cube 1: Measurement grid: dx=4.3mm, dy=4.3mm, dz=3mm

Reference Value = 2.03 V/m; Power Drift = 0.013 dB

Peak SAR (extrapolated) = 0.300 W/kg

SAR(1 g) = 0.081 mW/g; SAR(10 g) = 0.022 mW/g

Maximum value of SAR (measured) = 0.191 mW/g

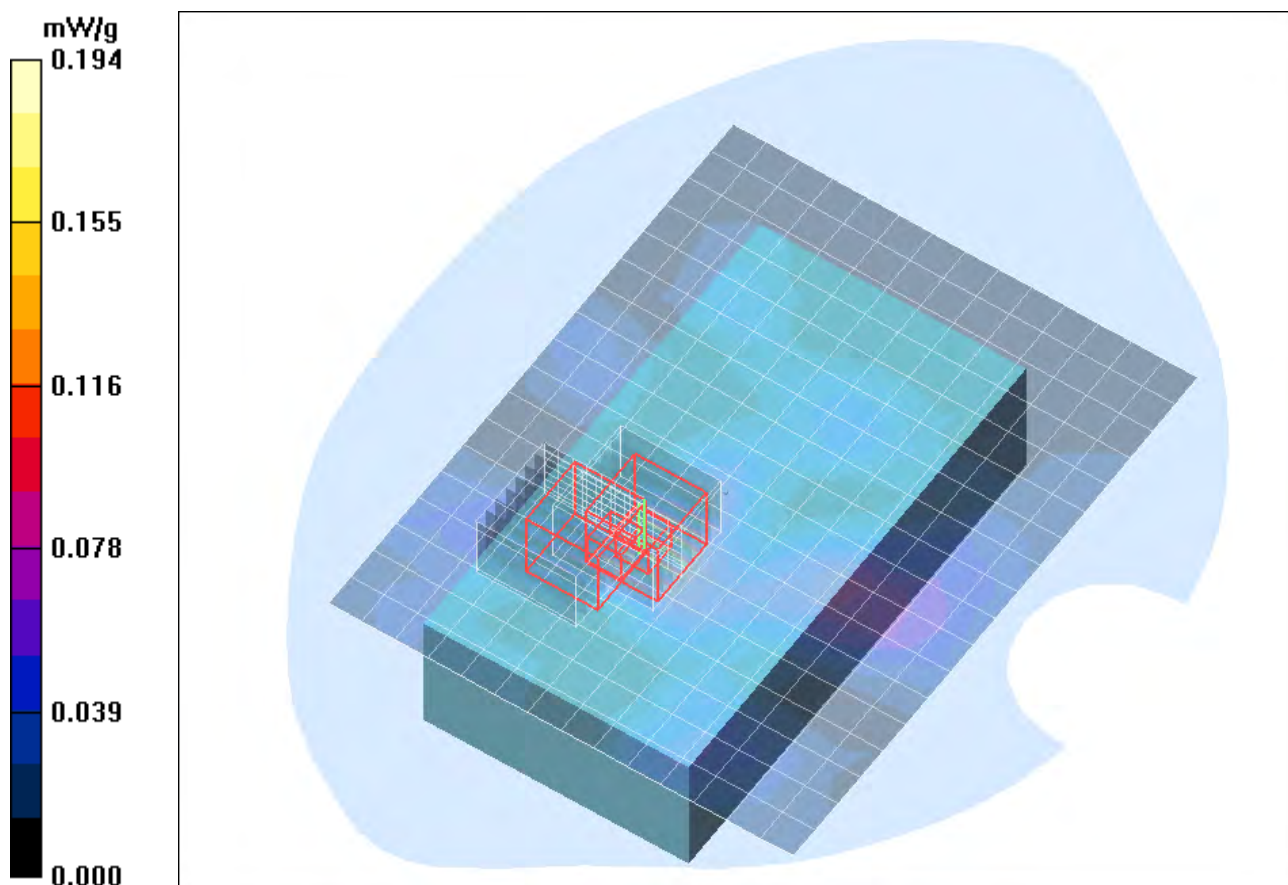

Fig. 94: SAR distribution for IEEE 802.11a, channel 161, body worn configuration, display towards the ground, 15 mm distance (May 14, 2010; Ambient Temperature: 21.8° C; Liquid Temperature: 21.2° C).

19 SAR Z-axis Scans (Validation)

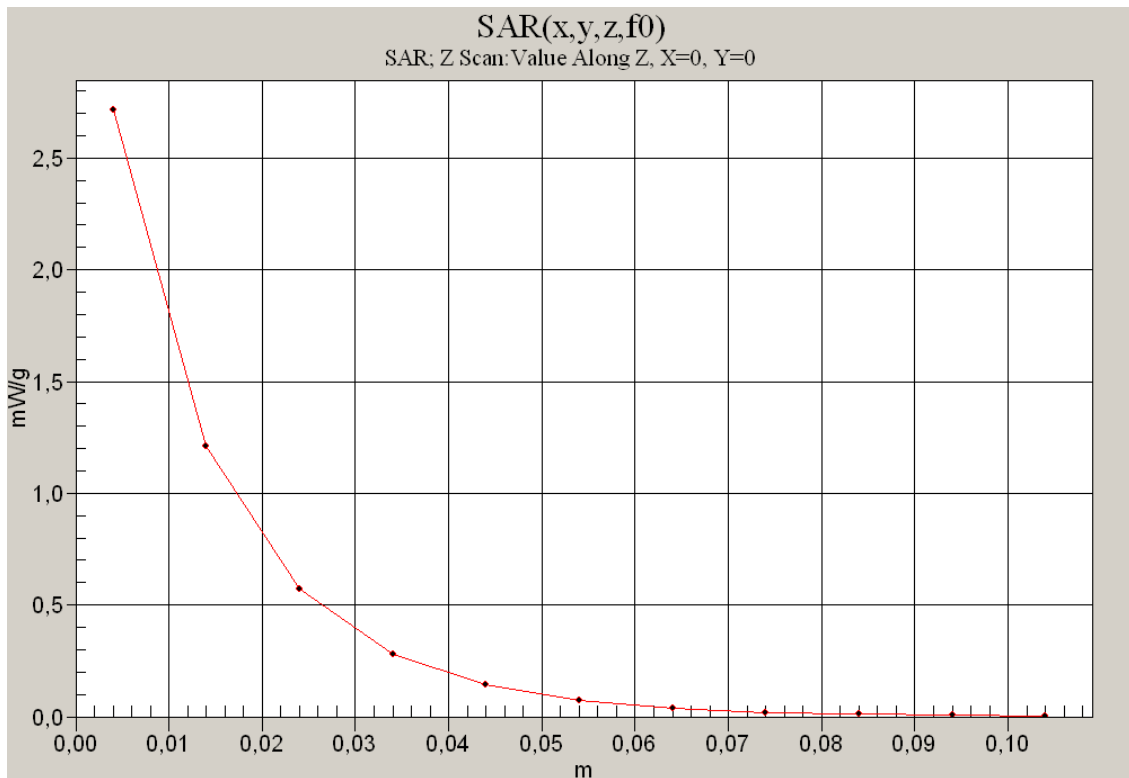

Fig. 95: SAR versus liquid depth, 835 MHz, head (July 20, 2010; Ambient Temperature: 21.0° C; Liquid Temperature : 20.6° C).

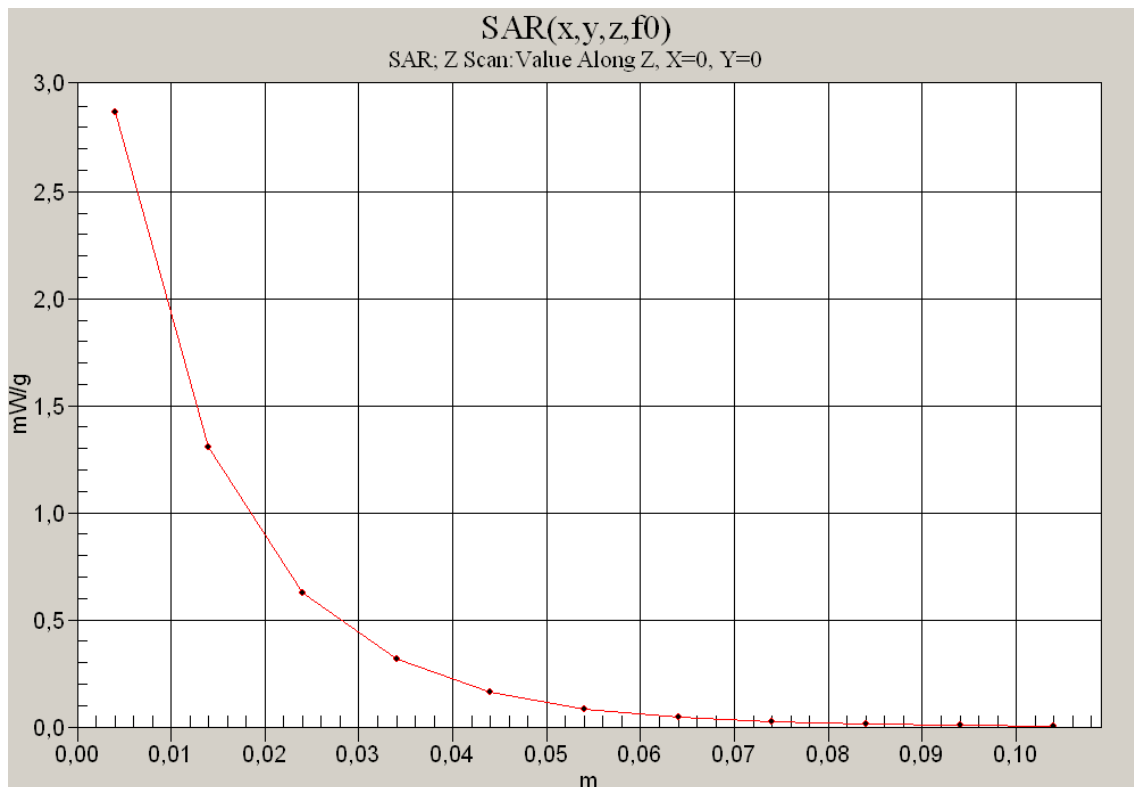

Fig. 96: SAR versus liquid depth, 835 MHz, body (July 26, 2010; Ambient Temperature: 21.1° C; Liquid Temperature : 20.7° C).

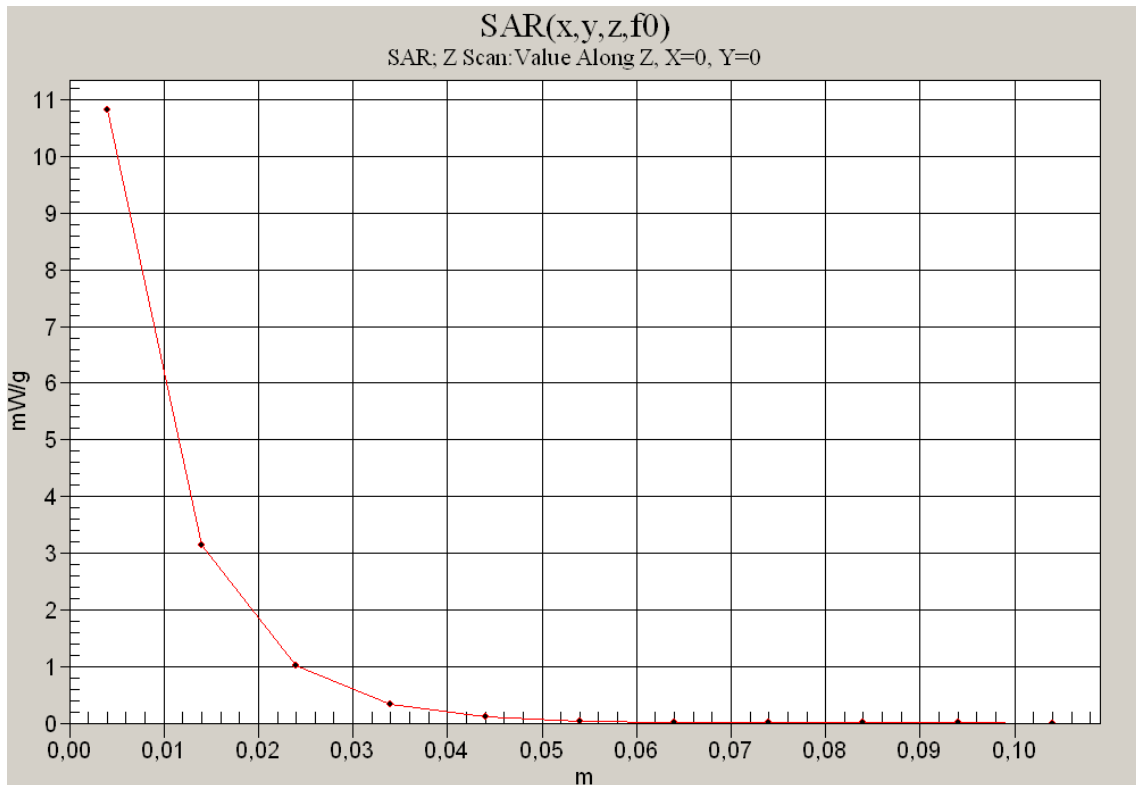

Fig. 97: SAR versus liquid depth, 1900 MHz, head (July 12, 2010; Ambient Temperature: 21.4° C; Liquid Temperature: 20.8° C).

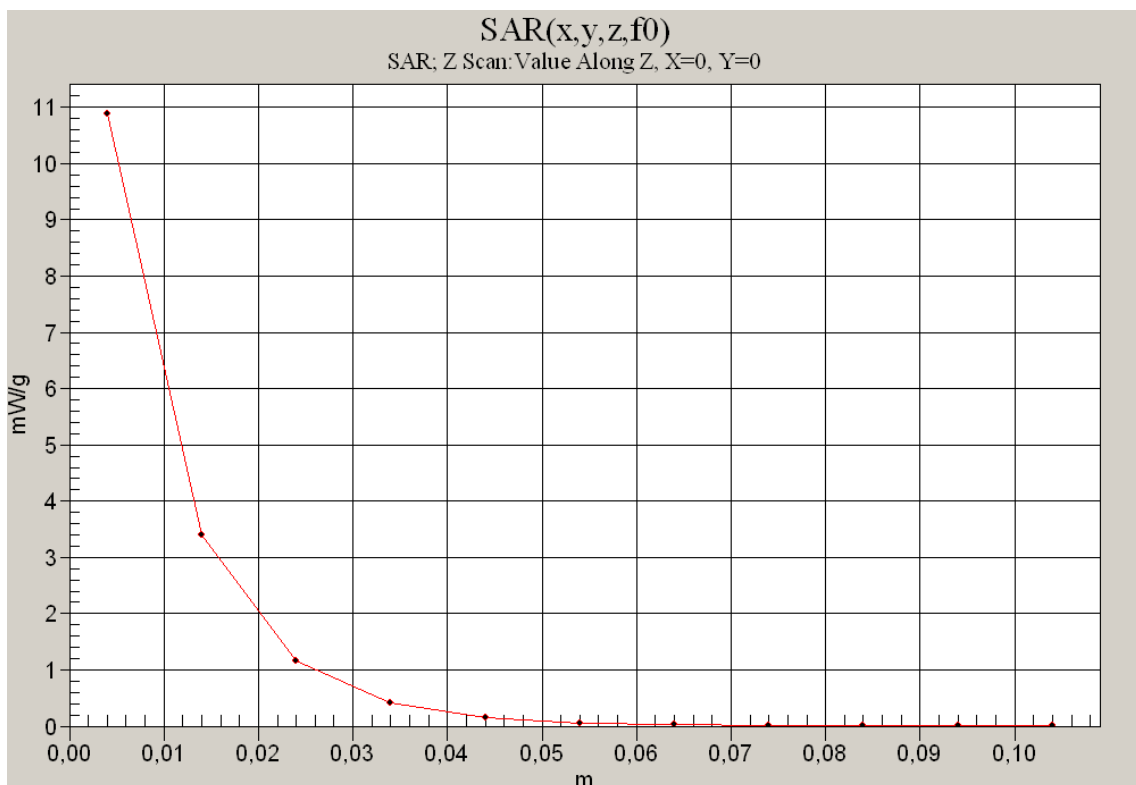

Fig. 98: SAR versus liquid depth, 1900 MHz, body (July 21, 2010; Ambient Temperature: 21.0° C; Liquid Temperature: 20.5° C).

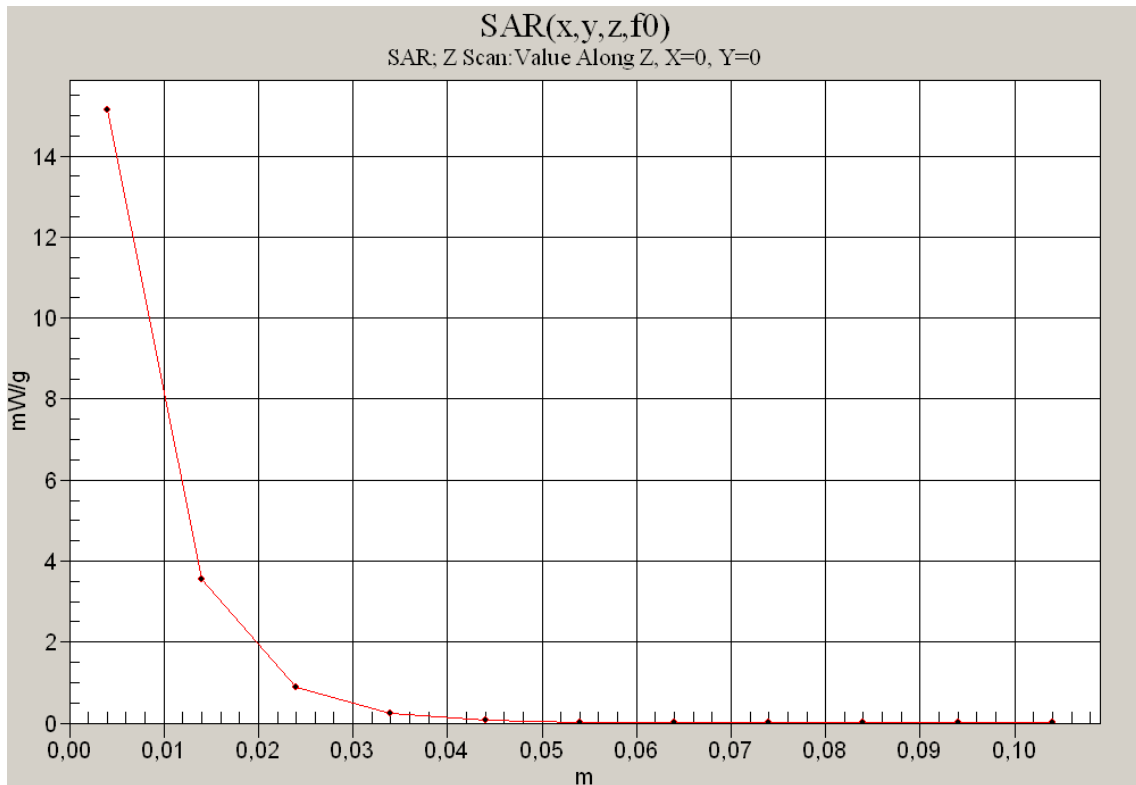

Fig. 99: SAR versus liquid depth, 2450 MHz, head (July 28, 2010; Ambient Temperature: 21.5° C; Liquid Temperature: 21.1° C).

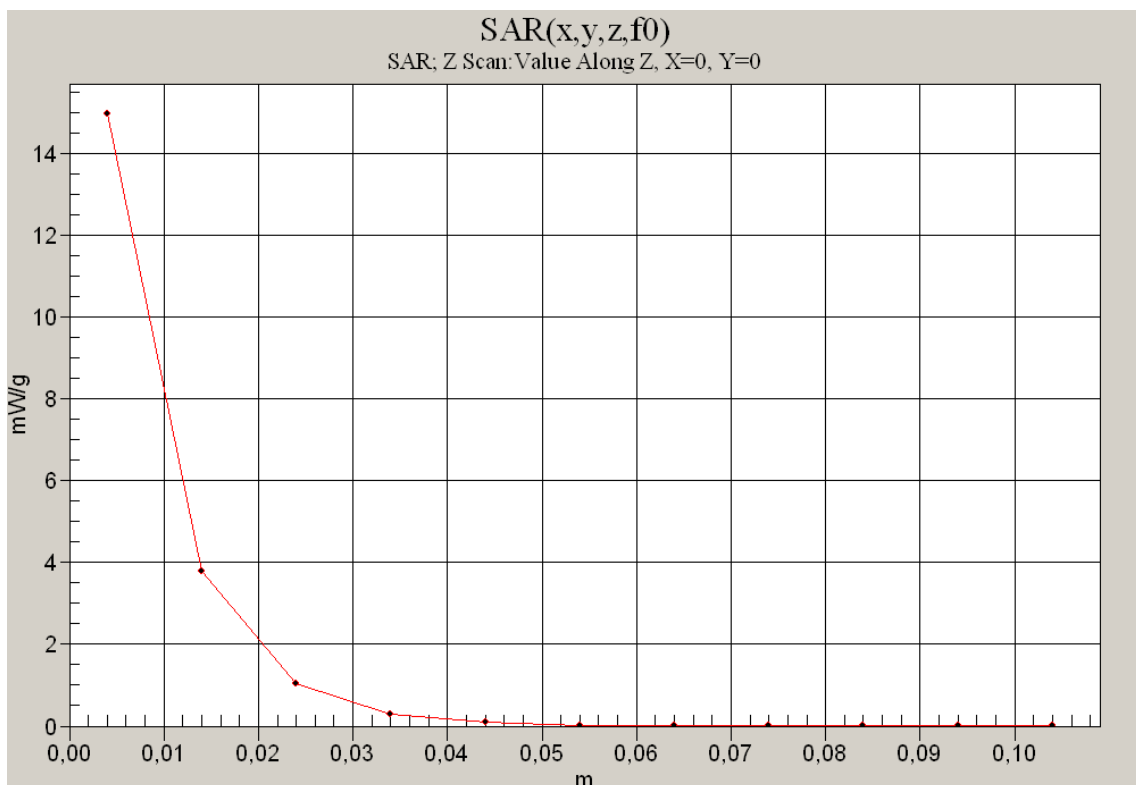

Fig. 100: SAR versus liquid depth, 2450 MHz, body (May 11, 2010; Ambient Temperature: 21.9° C; Liquid Temperature: 21.5° C).

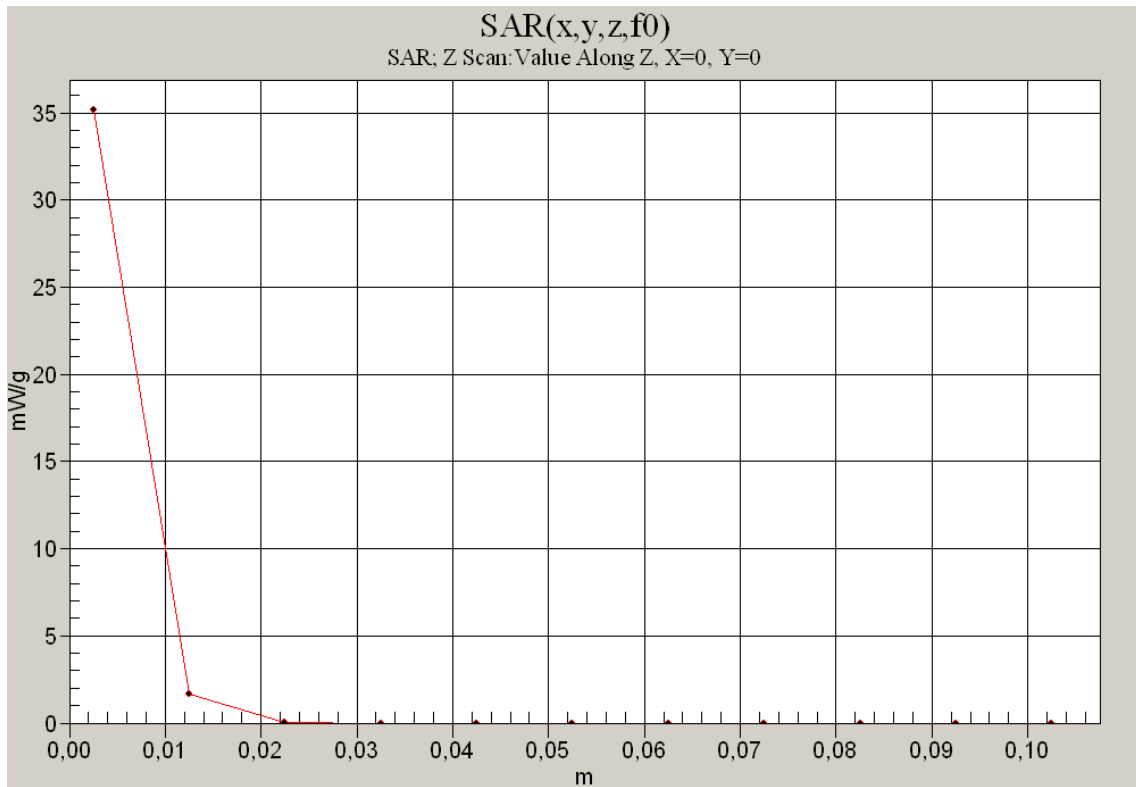

Fig. 101: SAR versus liquid depth, 5200 MHz, head (May 20, 2010; Ambient Temperature: 21.7° C; Liquid Temperature: 21.0° C).

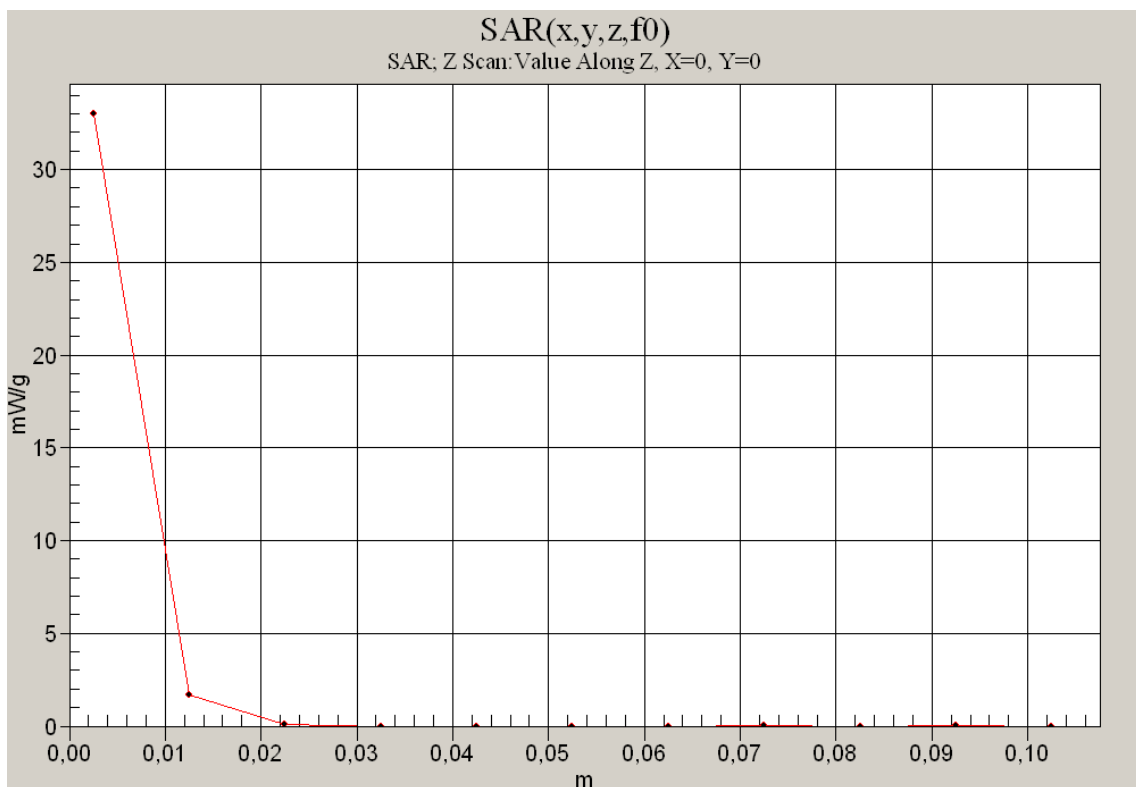

Fig. 102: SAR versus liquid depth, 5200 MHz, body (May 12, 2010; Ambient Temperature: 21.6° C; Liquid Temperature: 21.2° C).

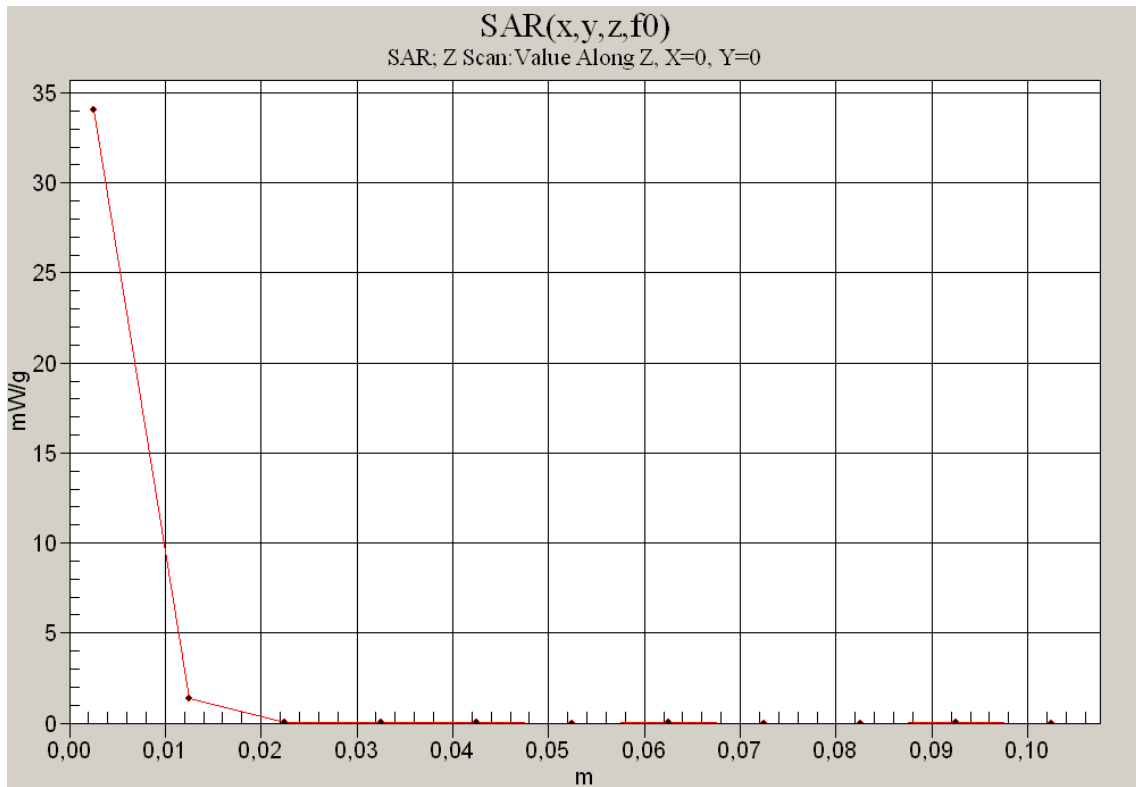

Fig. 103: SAR versus liquid depth, 5500 MHz, head (May 21, 2010; Ambient Temperature: 21.7° C; Liquid Temperature: 21.1° C).

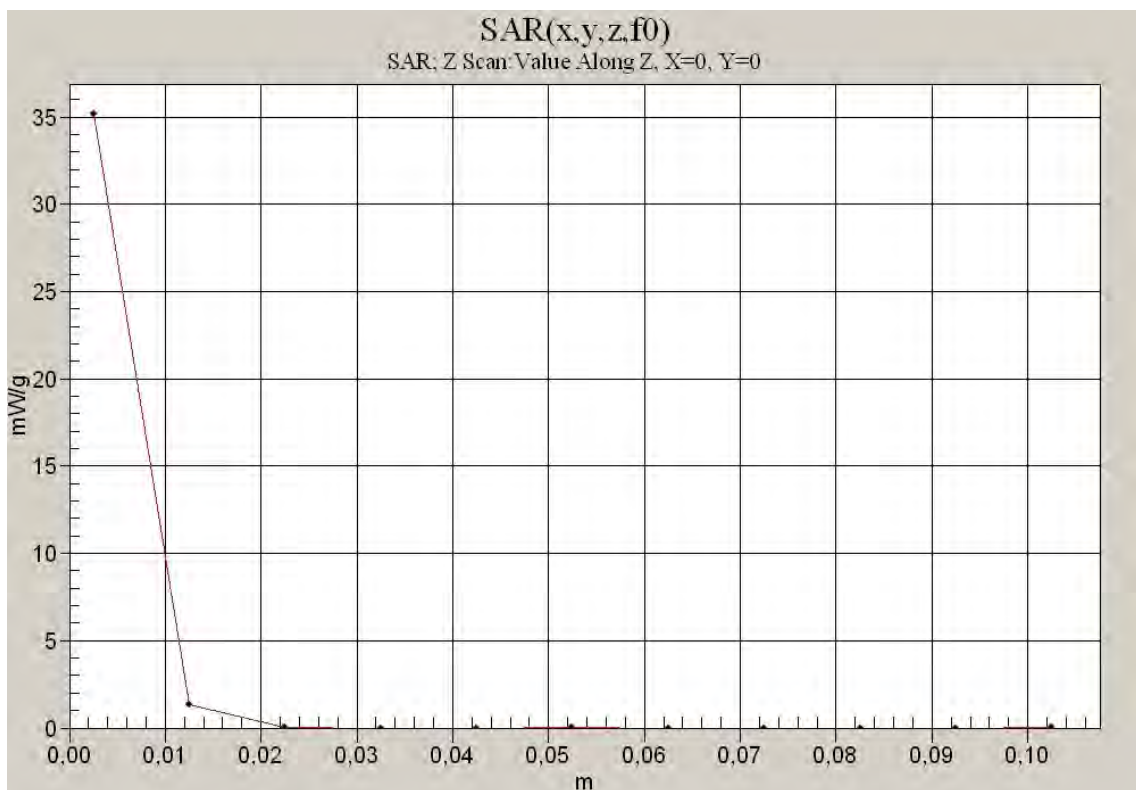

Fig. 104: SAR versus liquid depth, 5500 MHz, body (May 18, 2010; Ambient Temperature: 22.0° C; Liquid Temperature: 21.3° C).

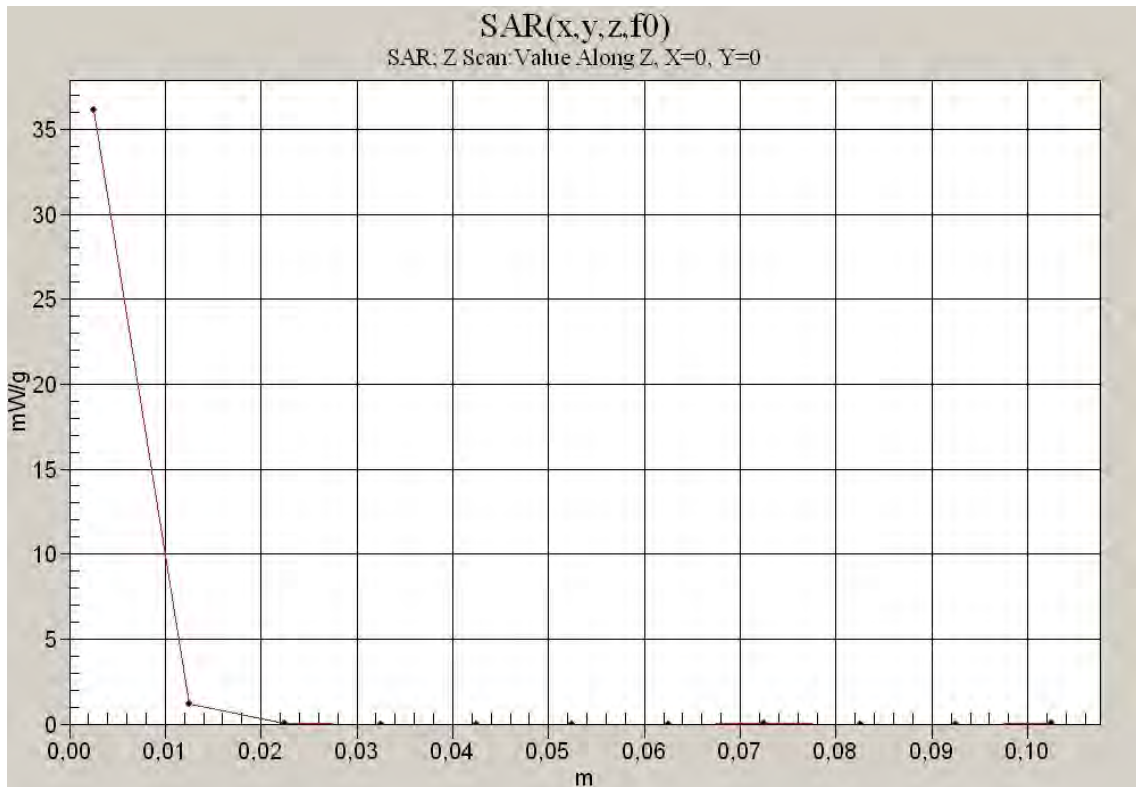

Fig. 105: SAR versus liquid depth, 5800 MHz, head (May 21, 2010; Ambient Temperature: 21.8° C; Liquid Temperature: 21.1° C).

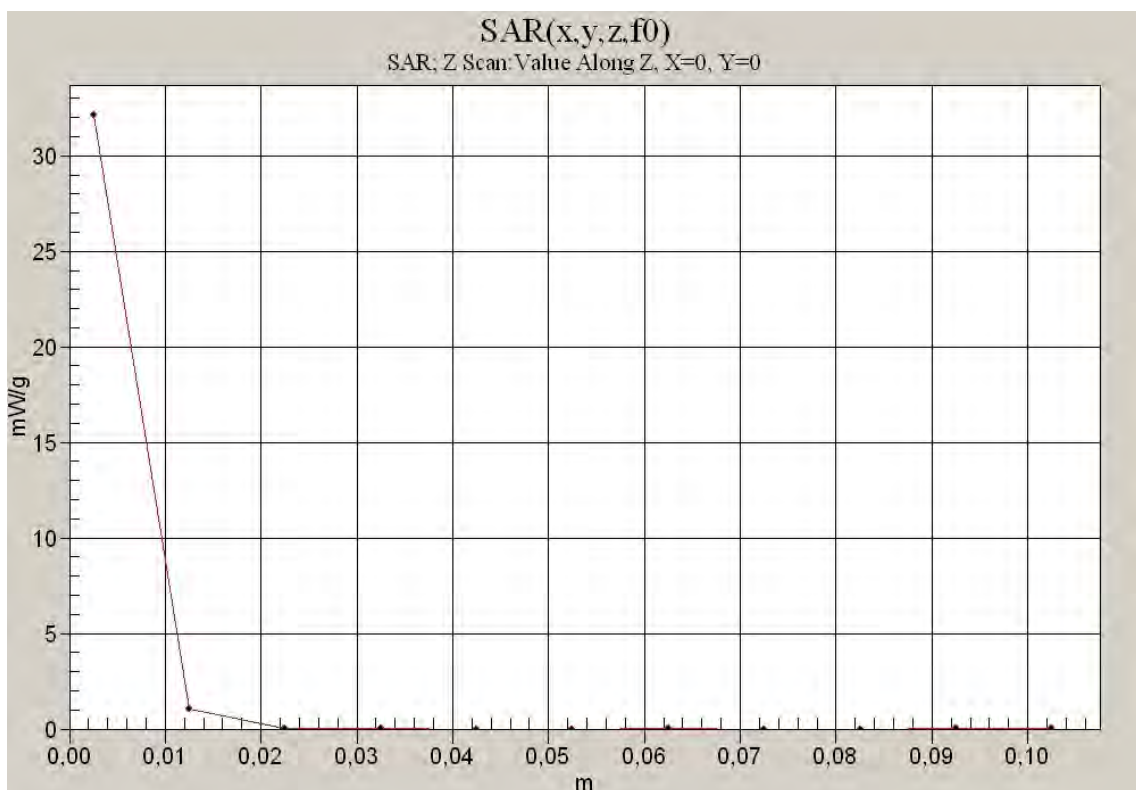

Fig. 106: SAR versus liquid depth, 5800 MHz, body (May 14, 2010; Ambient Temperature: 21.8° C; Liquid Temperature: 21.2° C).

20 SAR Z-axis Scans (Measurements)

The following pictures show the plots of SAR versus liquid depth for the worst case values.

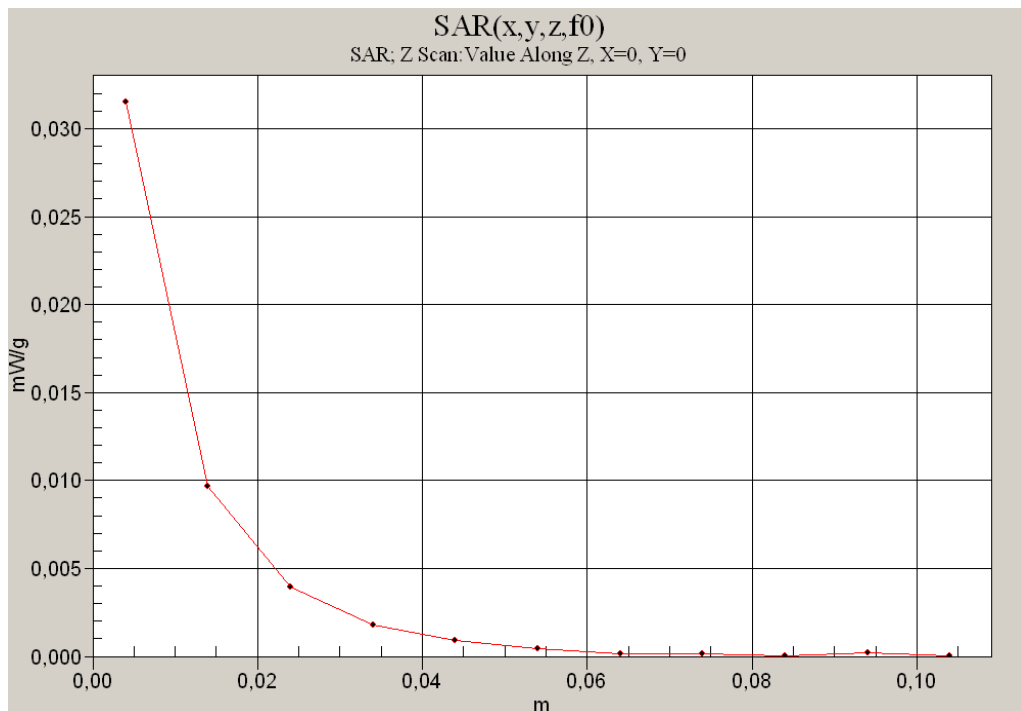

Fig. 107: SAR versus liquid depth, head: GSM 850, channel 190, tilted position, left side of head (July 20, 2010; Ambient Temperature: 21.1° C; Liquid Temperature: 20.6° C).

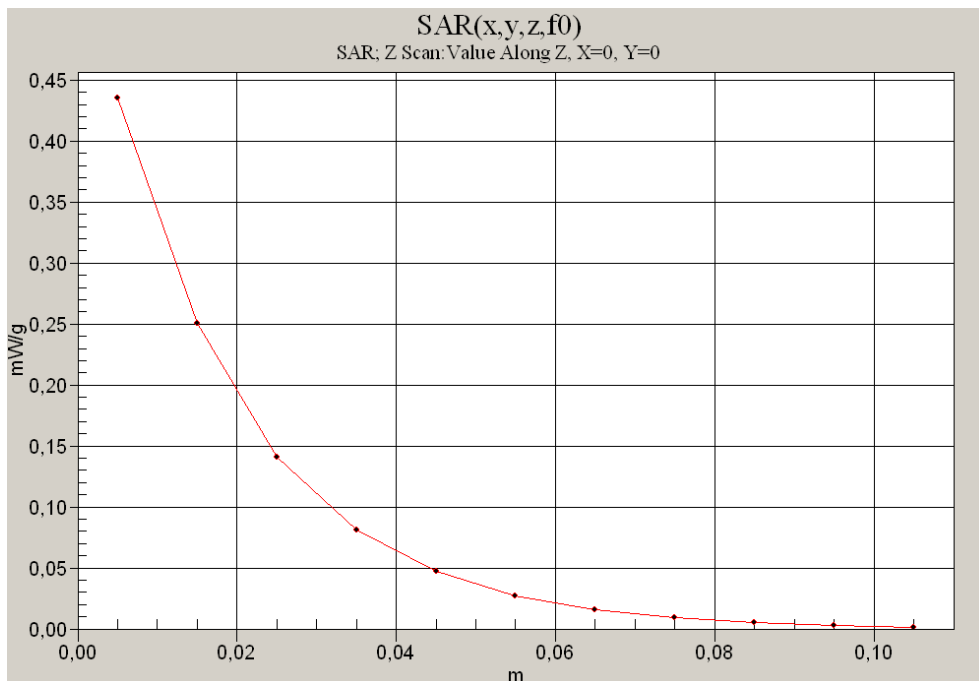

Fig. 108: SAR versus liquid depth, body: GPRS 850, channel 190, display towards the phantom (July 26, 2010; Ambient Temperature: 21.3° C; Liquid Temperature: 20.7° C).

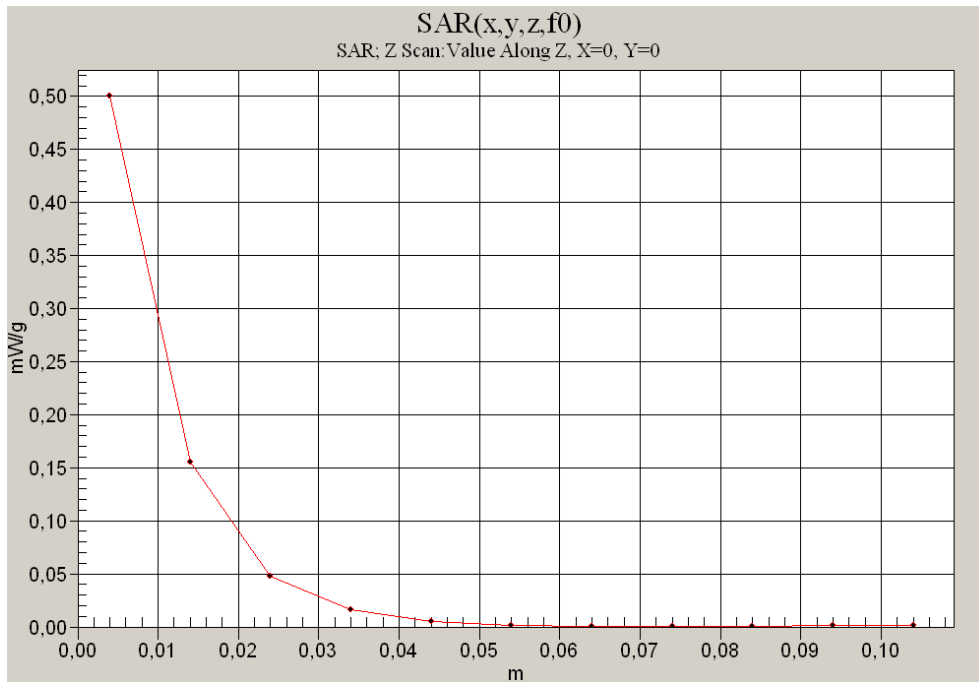

Fig. 109: SAR versus liquid depth, head: PCS 1900, channel 661, tilted position, left side of head (July 12, 2010; Ambient Temperature: 21.4° C; Liquid Temperature : 20.8° C).

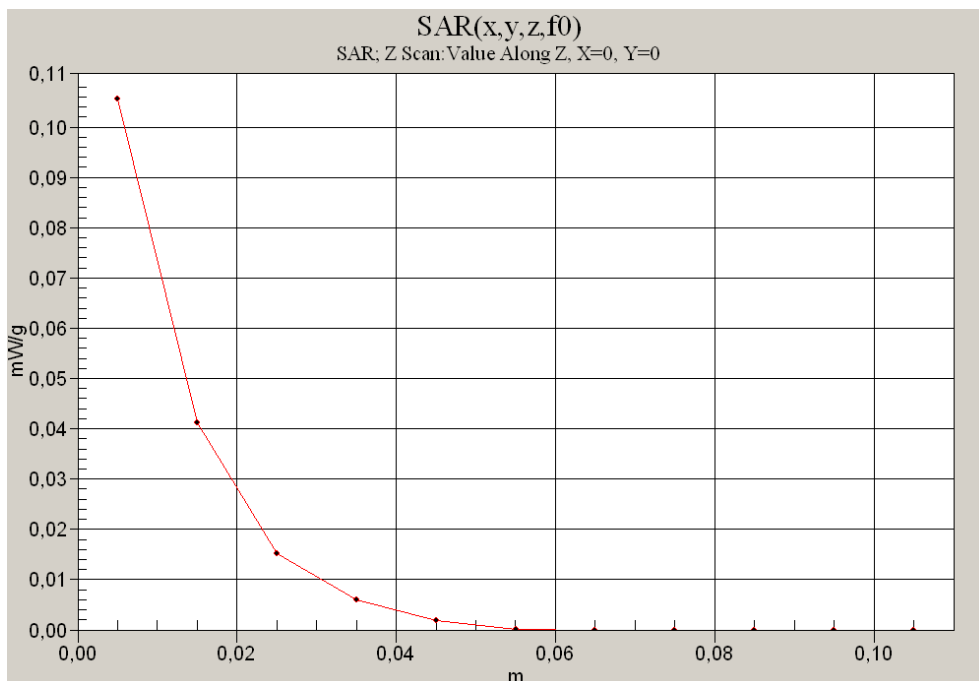

Fig. 110: SAR versus liquid depth, body: GPRS 1900, channel 661, display towards the ground (July 21, 2010; Ambient Temperature: 21.1° C; Liquid Temperature: 20.5° C).

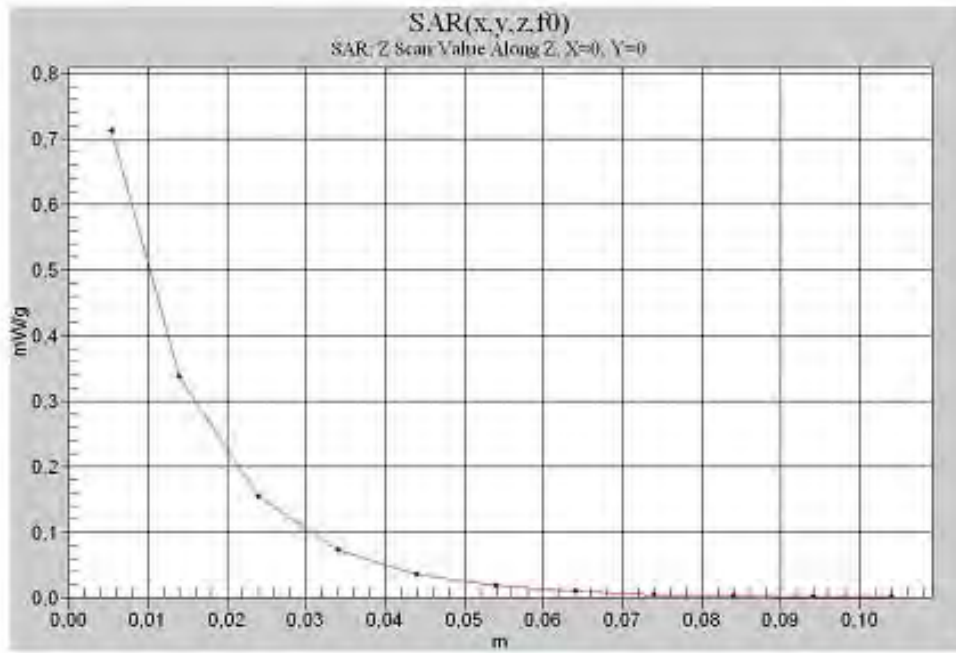

Fig. 111: SAR versus liquid depth, head: WCDMA V, channel 4183, tilted position, left side of head (July 20, 2010; Ambient Temperature: 21.3° C; Liquid Temperature: 20.7° C).

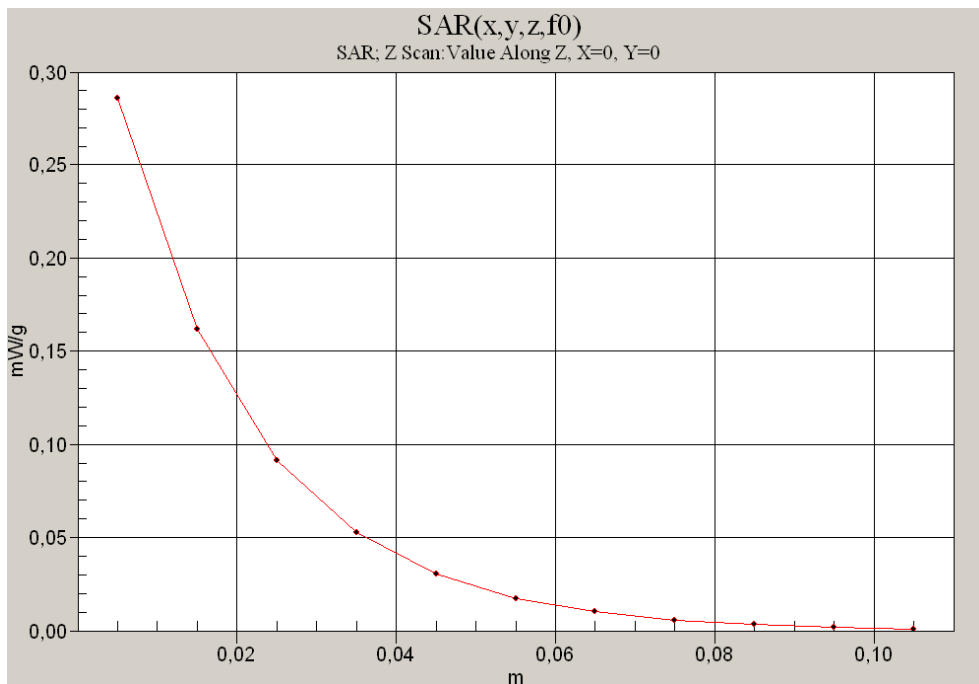

Fig. 112: SAR versus liquid depth, body: WCDMA V, channel 4183, display towards the phantom (July 26, 2010; Ambient Temperature: 21.2° C; Liquid Temperature: 20.7° C).

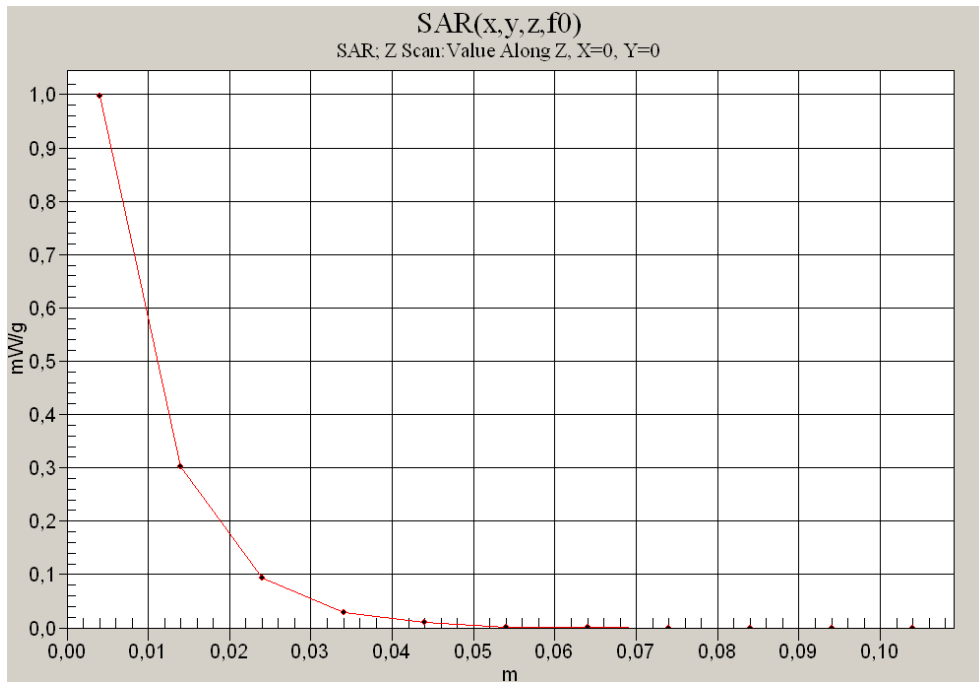

Fig. 113: SAR versus liquid depth, head: WCDMA II channel 9538, tilted position, left side of head (July 12, 2010; Ambient Temperature: 21.4° C; Liquid Temperature : 20.8° C).

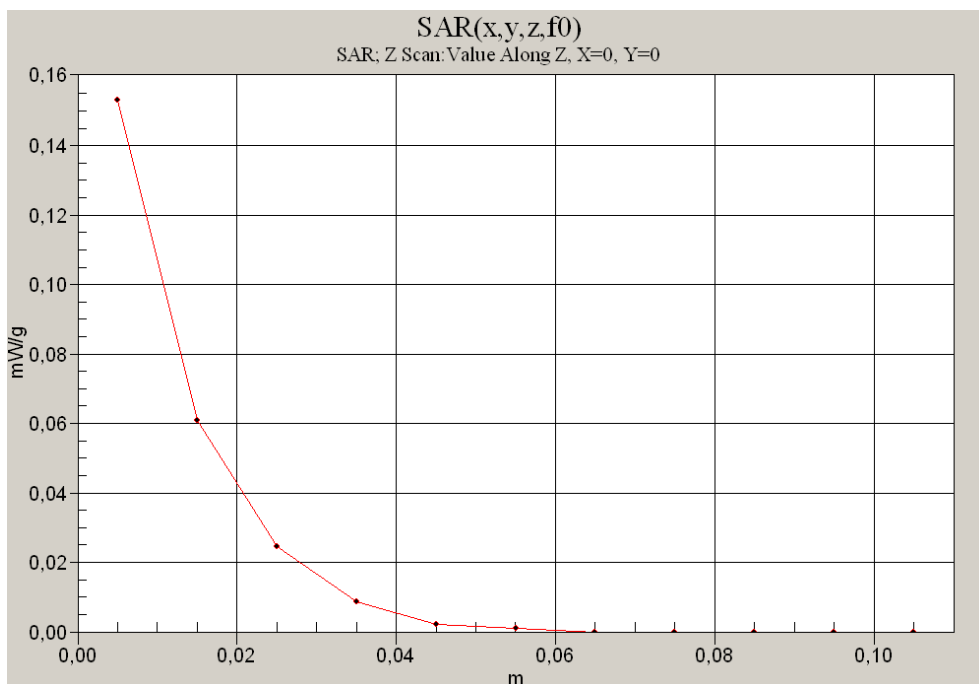

Fig. 114: SAR versus liquid depth, body: WCDMA II, channel 9400, display towards the ground (July 21, 2010; Ambient Temperature: 21.2° C; Liquid Temperature: 20.6° C).

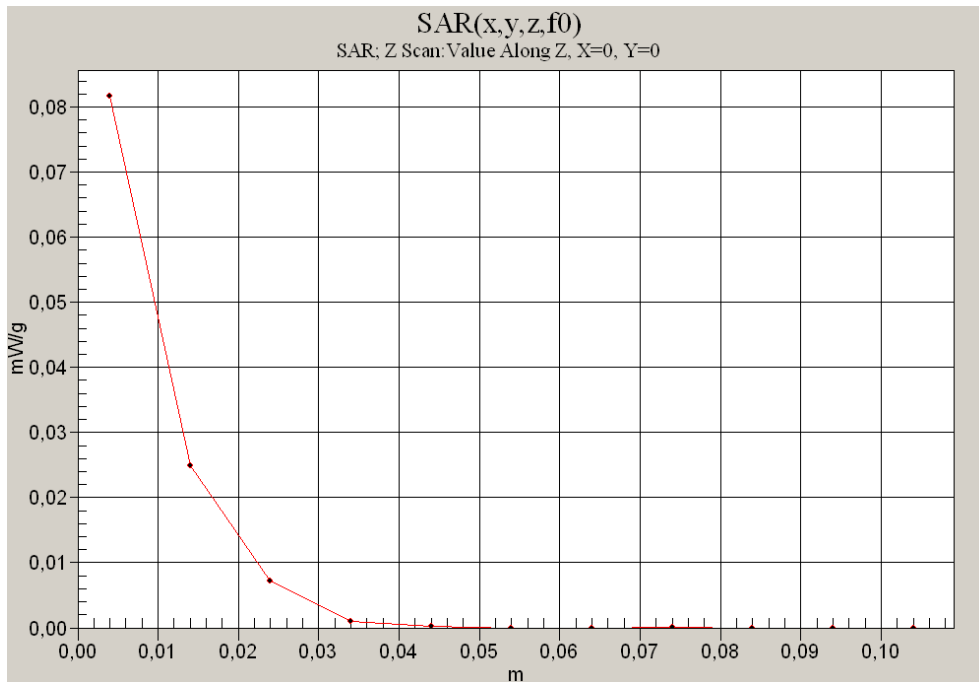

Fig. 115: SAR versus liquid depth, head: IEEE 802.11 g, channel 6, cheek position, left side of head (July 28, 2010; Ambient Temperature: 21.5° C; Liquid Temperature : 21.1° C).

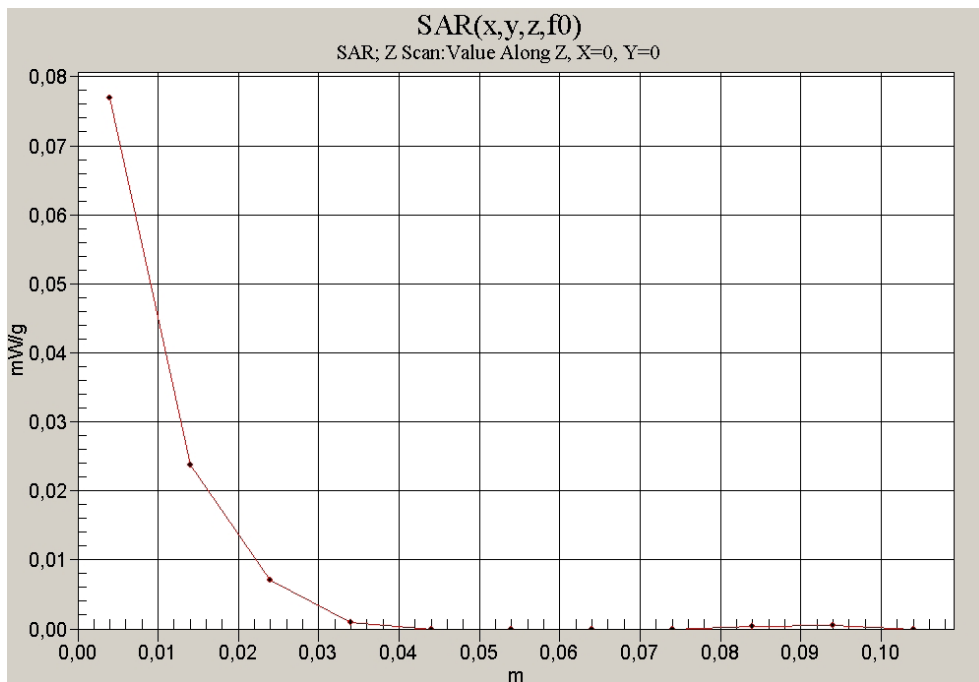

Fig. 116: SAR versus liquid depth, body: IEEE 802.11 g, channel 6, display towards the ground (May 11, 2010; Ambient Temperature: 21.2° C; Liquid Temperature: 20.9° C).

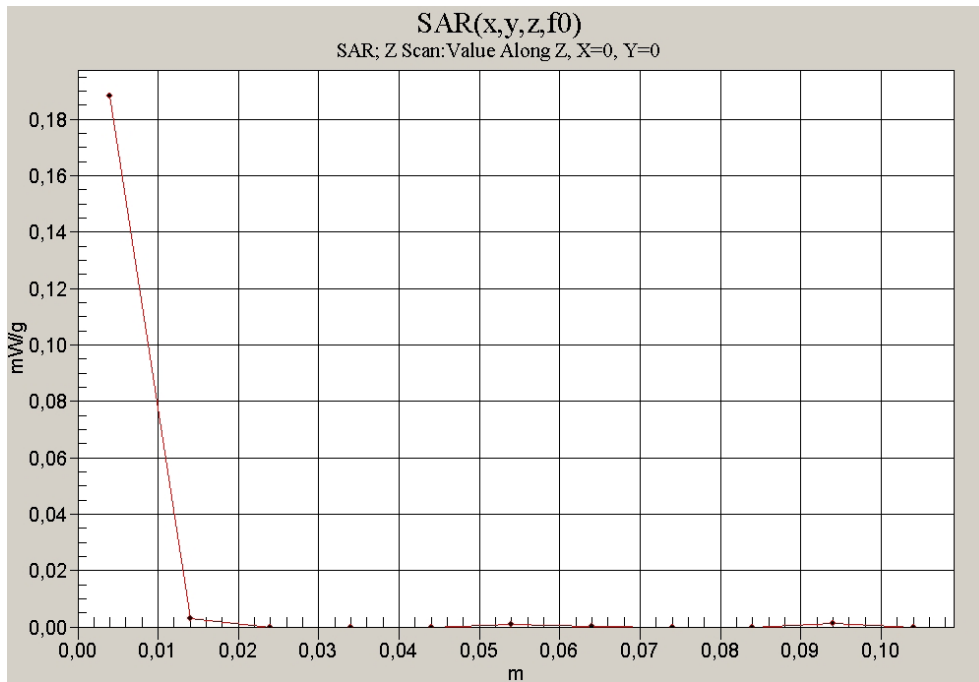

Fig. 117: SAR versus liquid depth, head: IEEE 802.11 a channel 36, cheek position, left side of head (May 20, 2010; Ambient Temperature: 21.7° C; Liquid Temperature : 21.1° C).

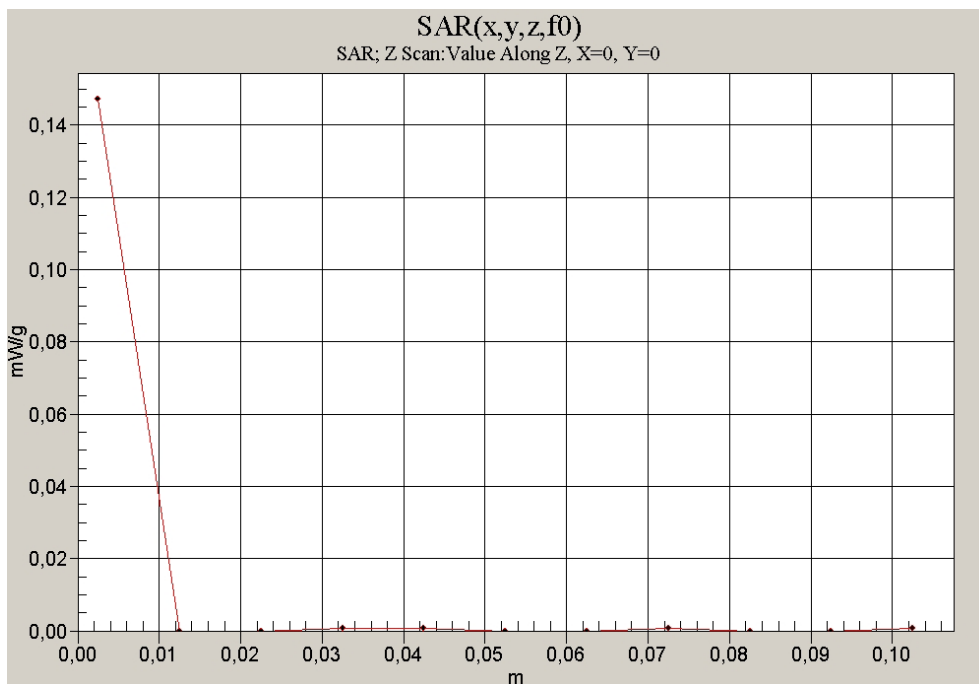

Fig. 118: SAR versus liquid depth, body: IEEE 802.11 a (5200 MHz range), channel 36, display towards the ground (May 12, 2010; Ambient Temperature: 21.6°C; Liquid Temperature: 21.2°C).

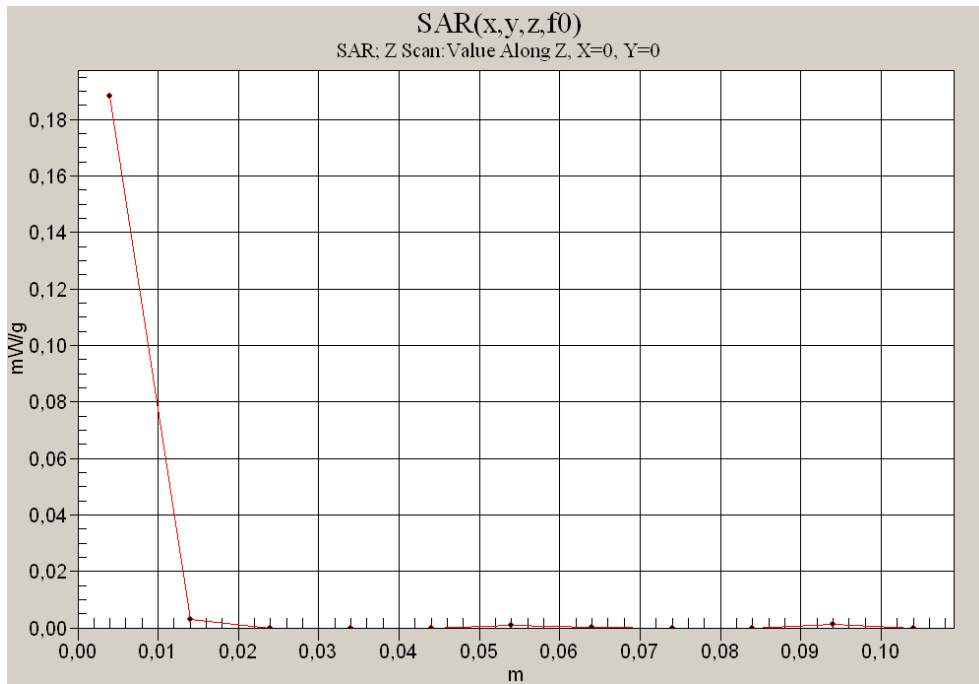

Fig. 119: SAR versus liquid depth, head: IEEE 802.11 a (5500 MHz range) channel 136, cheek position, left side of head (May 21, 2010; Ambient Temperature: 21.8° C; Liquid Temperature : 21.2° C).

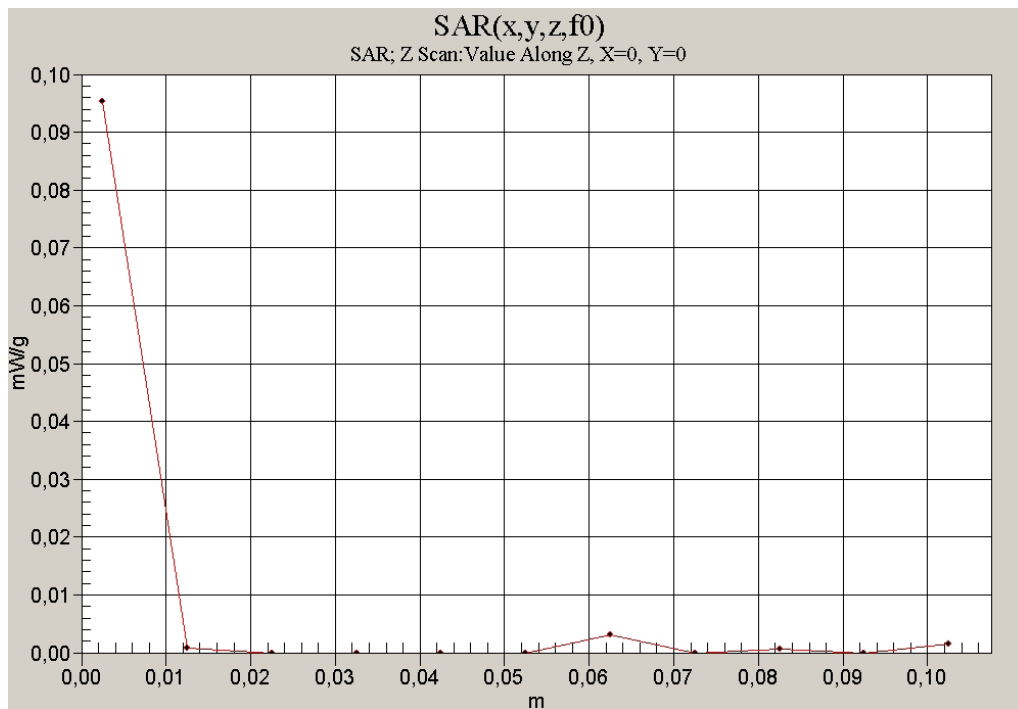

Fig. 120: SAR versus liquid depth, body: IEEE 802.11 a (5500 MHz range), channel 124, display towards the ground (May 18, 2010; Ambient Temperature: 21.9°C; Liquid Temperature: 21.3°C).

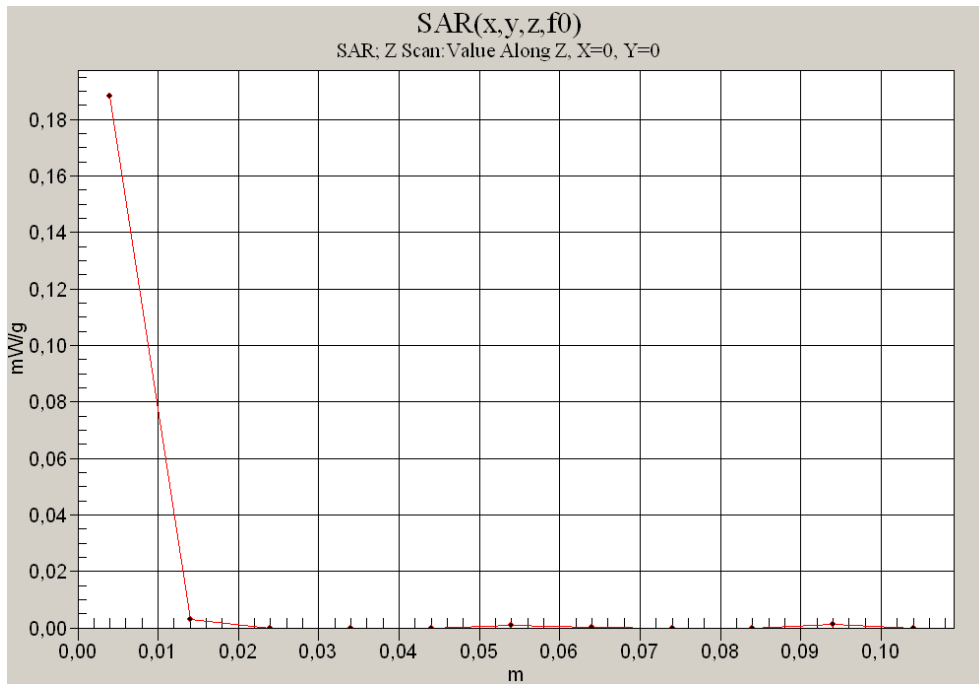

Fig. 121: SAR versus liquid depth, head: IEEE 802.11 a (5800 MHz range) channel 161, cheek position, left side of head (May 21, 2010; Ambient Temperature: 21.9° C; Liquid Temperature : 21.3° C).

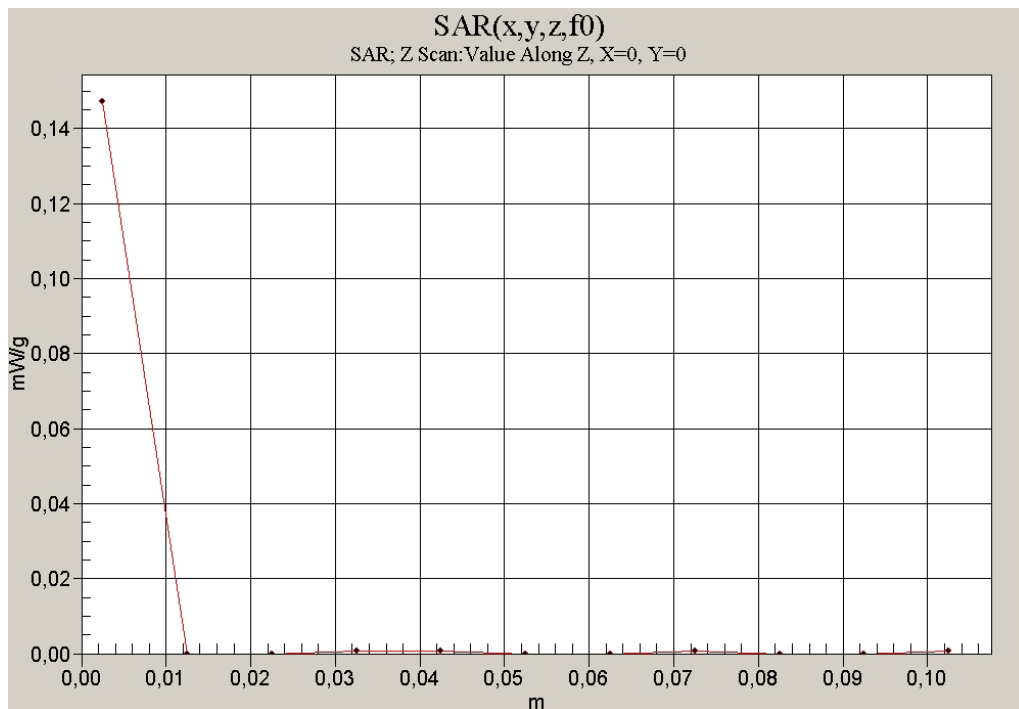

Fig. 122: SAR versus liquid depth, body: IEEE 802.11 a (5800 MHz range), channel 161, display towards the ground (May 14, 2010; Ambient Temperature: 21.8°C; Liquid Temperature: 21.2°C).