

# IT1200 LABELS LIST

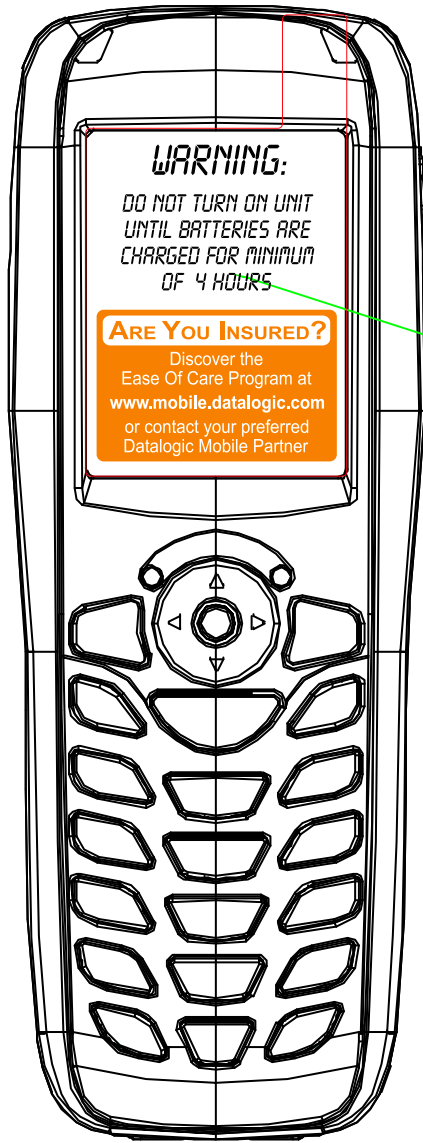

1  
Display  
Protect film

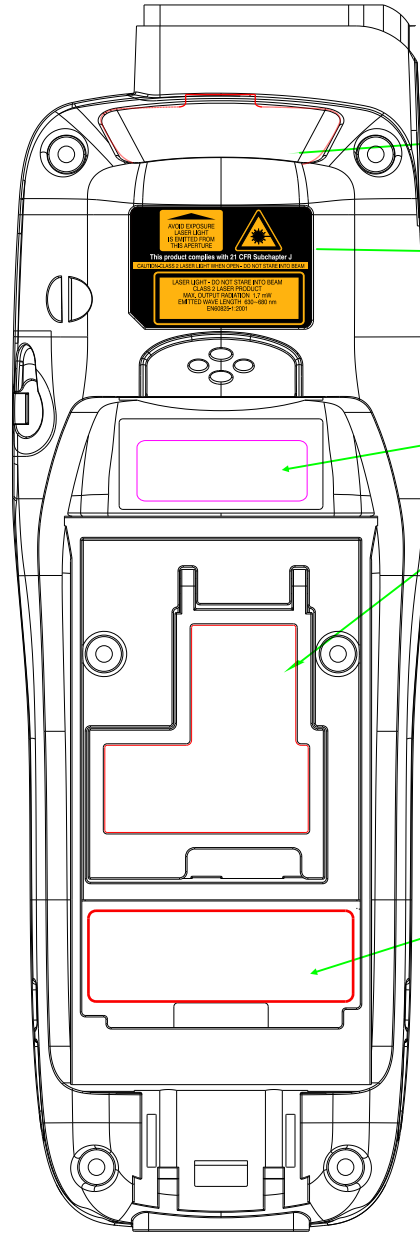

2 SCAN WINDOW 1D+2D FILM  
34.3 x 15.5 mm

3 (1D+2D)  
Laser Warning Label  
24 x 16 mm

4 WinCE 6.1 label

5 System Label  
26.8 X 27.3 mm

6 Model No. label 35 x 12 mm

| REV | DATE | DESCRIPTION | DESIGN | D'APP |
|-----|------|-------------|--------|-------|
|     |      |             |        |       |

|  |   |                              |          |     |
|--|---|------------------------------|----------|-----|
|  銀鏘科技股份有限公司 |   |                              |          |     |
| :SCALE   | :UNIT   | :MODEL<br>IT1200 Labels List |          |     |
| :FINISH  |   | :MATERIAL                    |          |     |
| :DESIGN<br>Vicki-lin   |   | :TITLE<br>GSM                |          |     |
| :CHK   |   | :N/P                         |          |     |
| :D'APP   |   | :N/P                         |          |     |
| 4A   |  | SHEET 1 OF                   | FILENAME | REV |

|      |  |
|------|--|
| SIGN |  |
|      |  |
| P    |  |
|      |  |
| M    |  |
|      |  |

# ITFM 1

## Display Protect film

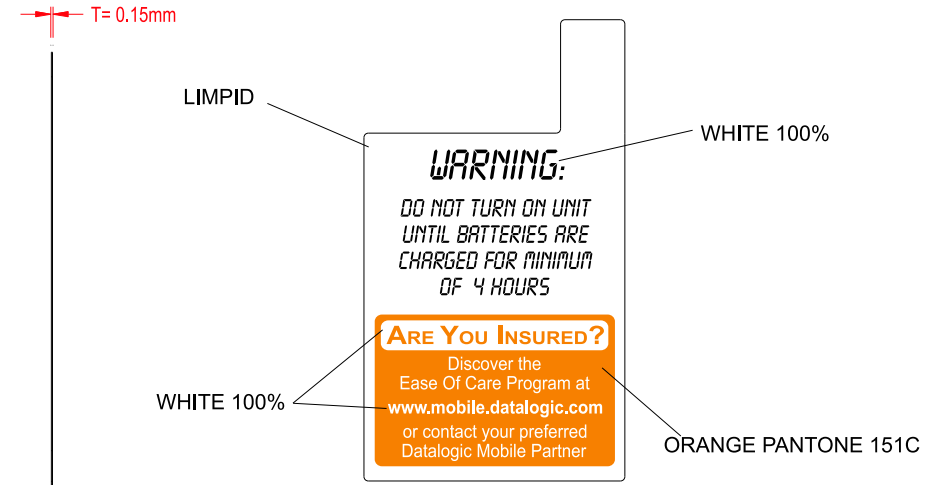
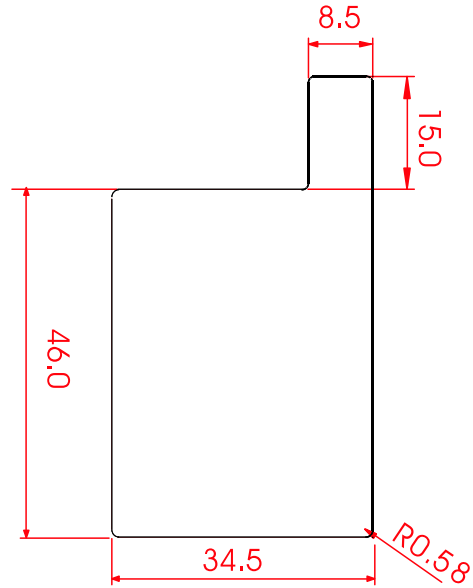
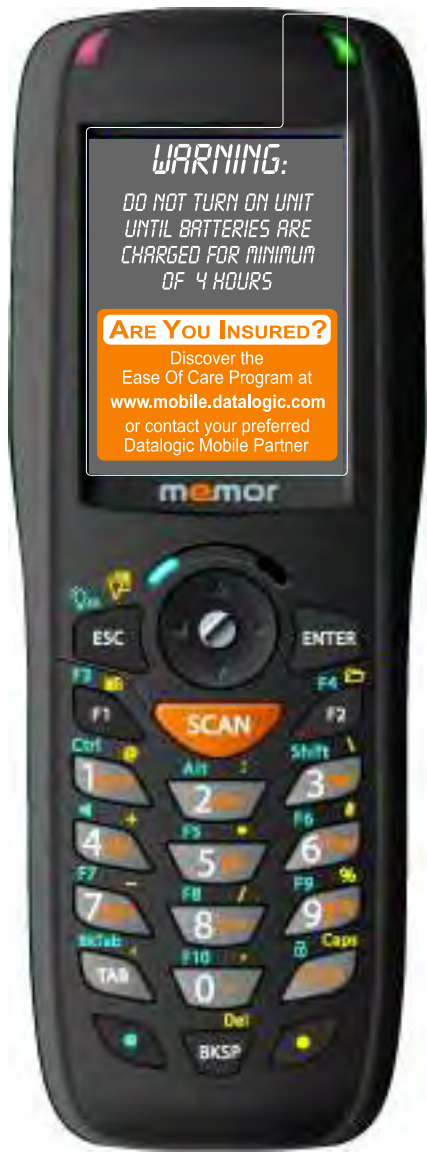

|      |   |
|------|---|
| SIGN |   |
| P    | M |

|            |                      |              |               |
|------------|----------------------|--------------|---------------|
| 銀鑽科技股份有限公司 |                      |              |               |
| :SCALE     | 1:1                  | :UNIT        | mm            |
| :MODEL     | IT1200               |              |               |
| :FINISH    | PET                  |              | :MATERIAL     |
| :DESIGN    | Vicki-lin            |              | :TITLE        |
| :CHK       | Display Protect film |              |               |
| :D'APP     | :VP                  |              | 4G62-ZZ001501 |
| 4A         |                      | SHEET 1 of 1 | :FILENAME     |
|            |                      |              | REV           |

| REV | DATE | DESCRIPTION | DESIGN | D'APP |
|-----|------|-------------|--------|-------|
|     |      |             |        |       |



# ITFM 2

## SCAN WINDOW 1D FILM

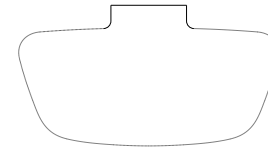
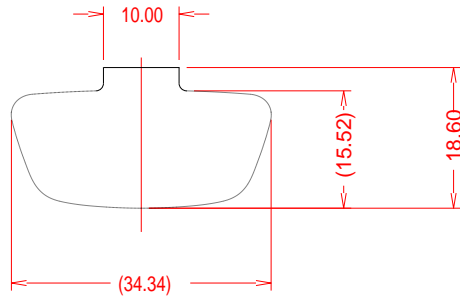
| REV | DATE | DESCRIPTION | DESIGN | D'APP |
|-----|------|-------------|--------|-------|
|     |      |             |        |       |



| Unspecified TOLERANCE |       |
|-----------------------|-------|
| L<=3                  | ±0.03 |
| 3<L<=10               | ±0.05 |
| 10<L<=30              | ±0.08 |
| 30<L<=50              | ±0.10 |
| 50<L<=100             | ±0.15 |
| >100                  | ±0.20 |
| ANGLE                 | ±0.5° |

|  銀鐸科技股份有限公司 |   |            |                     |
|--|---|------------|---------------------|
| :SCALE   | 1:1   | :UNIT      | mm                  |
| :MODEL   | It1200 Labels List  |            |                     |
| :FINISH  | see NOTES   | :MATERIAL  | see NOTES           |
| :DESIGN  | TONY  | :TITLE     | SCAN WINDOW 1D FILM |
| :CHK   |   | :N/P       | 4G60-AA002001       |
| :D'APP   |   | :FILENAME  |                     |
| 4A   |  | SHEET 1 OF | REV                 |

|        |      |
|--------|------|
| P<br>M | SIGN |
|        |      |

ITFM 2

SCAN WINDOW 2D FILM

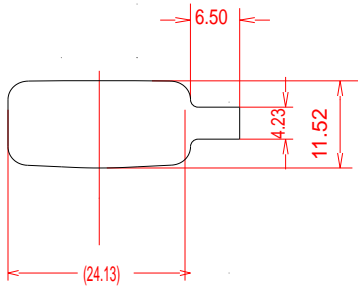

1:1



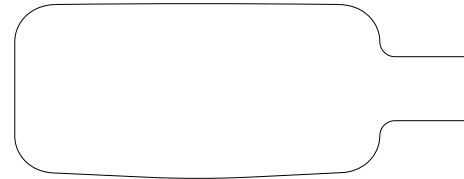

100% Size

2:1



| Unspecified TOLERANCE |       |
|-----------------------|-------|
| L<=3                  | ±0.03 |
| 3<L<=10               | ±0.05 |
| 10<L<=30              | ±0.08 |
| 30<L<=50              | ±0.10 |
| 50<L<=100             | ±0.15 |
| >100                  | ±0.20 |
| ANGLE                 | ±0.5° |

|        |      |
|--------|------|
| P<br>M | SIGN |
|        |      |

|  |   |            |                     |
|--|---|------------|---------------------|
|  銀鏘科技股份有限公司 |   |            |                     |
| :SCALE   | 1:1   | :UNIT      | mm                  |
| :MODEL   | IT1200 Labels List  |            |                     |
| :FINISH  | see NOTES   |            | :MATERIAL see NOTES |
| :DESIGN  | TONY  |            | :TITLE              |
| :CHK   |   |            | SCAN WINDOW 2D FILM |
| :D'APP   |   |            | :N/P 4G62-ZZ001401  |
| 4A   |  | SHEET 1 OF | :FILENAME           |
|  |   |            | :REV                |

| REV | DATE | DESCRIPTION | DESIGN | D'APP |
|-----|------|-------------|--------|-------|
|     |      |             |        |       |

# ITFM 3 1D WERNING LABEL

1:1



100% Size  
Print Reference

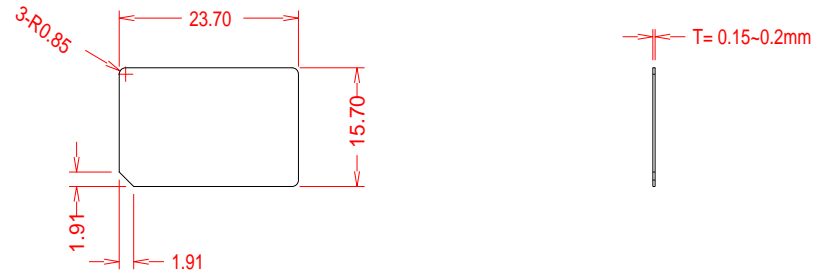

2:1



- - BACKGROUND COLOR PANTONE BLACK 6C
- - BLACK CHARACTERS SWS721 PANTONE BLACK 6C
- - WHITE CHARACTERS SWIS721 BOLD WHITE 100%
- - YELLOW PANTONE 123C

MATER. 3M 3690

DIMENSIONS WITHOUT TOLERANCE DEGREE:  
±0.1

| PRECISION DEGREE | DIMENSIONAL GROUPS |      |       |      |      |
|------------------|--------------------|------|-------|------|------|
|                  | >0                 | >6   | >30   | >120 | >315 |
| MEDIUM           | ±0.1               | ±0.2 | ±0.3  | ±0.5 | ±0.8 |
| PRECISE          | ±0.05              | ±0.1 | ±0.15 | ±0.2 | ±0.3 |

All materials employed have to be selected among RoHS compliant materials: the EC directives to be referred to are 2002/95/EC and correlated subsequent ones.

| REV | DATE | DESCRIPTION | DESIGN | D'APP |
|-----|------|-------------|--------|-------|
|     |      |             |        |       |

|      |   |
|------|---|
| SIGN |   |
| P    | M |

|            |           |              |               |           |                  |
|------------|-----------|--------------|---------------|-----------|------------------|
| 銀鑽科技股份有限公司 |           |              |               |           |                  |
| :SCALE     | 1:1       | :UNIT        | mm            | :MODEL    | IT1200           |
| :FINISH    |           | :MATERIAL    | MYLAR         | :TITLE    | 1D WERNING LABEL |
| :DESIGN    | Vicki-lin | :CHK         |               |           |                  |
| :D'APP     |           | :NVP         | 4G62-BB000701 | :FILENAME |                  |
| 4A         |           | SHEET 1 of 1 |               | REV       |                  |

# ITFM 3 2D WERNING LABEL

1:1

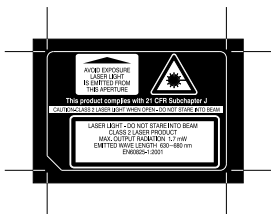

100% Size  
Print Reference

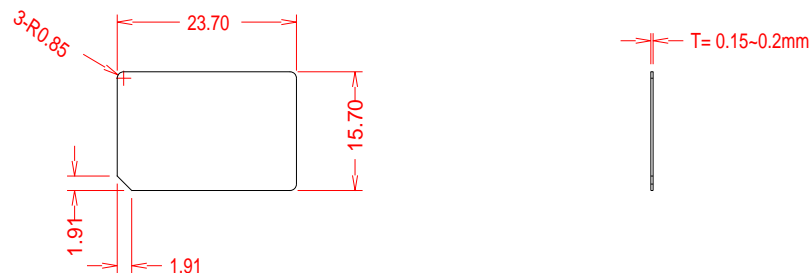
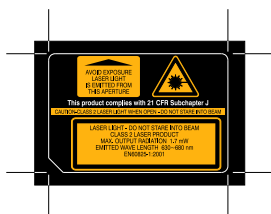

2:1



- - BACKGROUND COLOR PANTONE BLACK 6C
- - BLACK CHARACTERS SWS721 PANTONE BLACK 6C
- - WHITE CHARACTERS SWIS721 BOLD WHITE 100%
- - YELLOW PANTONE 123C

MATER. 3M 3690

DIMENSIONS WITHOUT TOLERANCE DEGREE:  
±0.1

| PRECISION DEGREE | DIMENSIONAL GROUPS |       |       |       |      |
|------------------|--------------------|-------|-------|-------|------|
|                  | >0                 | >6    | >30   | >120  | >315 |
| A 6              | A 30               | A 120 | A 315 | A 999 |      |
| MEDIUM           | ±0.1               | ±0.2  | ±0.3  | ±0.5  | ±0.8 |
| PRECISE          | ±0.05              | ±0.1  | ±0.15 | ±0.2  | ±0.3 |

All materials employed have to be selected among RoHS compliant materials:  
the EC directives to be referred to are 2002/95/EC and correlated subsequent ones.

| REV | DATE | DESCRIPTION | DESIGN | D'APP |
|-----|------|-------------|--------|-------|
|     |      |             |        |       |

|      |   |
|------|---|
| SIGN |   |
| P    | M |

|            |           |              |               |           |                  |
|------------|-----------|--------------|---------------|-----------|------------------|
| 銀鑽科技股份有限公司 |           |              |               |           |                  |
| :SCALE     | 1:1       | :UNIT        | mm            | :MODEL    | IT1200           |
| :FINISH    |           | :MATERIAL    | MYLAR         | :TITLE    | 2D WERNING LABEL |
| :DESIGN    | Vicki-lin | :CHK         |               |           |                  |
| :D'APP     |           | :NVP         | 4G60-BB000501 | :FILENAME | REV              |
| 4A         |           | SHEET 1 of 1 |               |           |                  |

ITFM 5 System Label  
(For 944201017 /944201018)

| REV | DATE | DESCRIPTION | DESIGN | D'APP |
|-----|------|-------------|--------|-------|
|     |      |             |        |       |

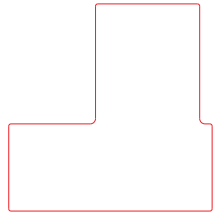

1:1

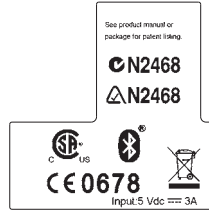

100% Size  
Print Reference

2:1

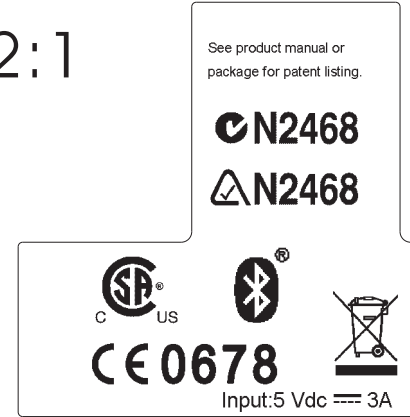

|      |   |
|------|---|
| SIGN |   |
| P    | M |

|                      |  |             |  |     |
|----------------------|--|-------------|--|-----|
| 銀鑽科技股份有限公司           |  |             |  |     |
| :SCALE<br>1:1        |  | :UNIT<br>MM | :MODEL<br>It1200                                     |     |
| :FINISH              |  |             | :MATERIAL<br>Semi-bright Silver                      |     |
| :DESIGN<br>Vicki-lin |  |             | :TITLE<br>System Label<br>(For 944201017 /944201018) |     |
| :CHK                 |  |             | :D'APP   |     |
| :D'APP               |  |             | :NVP<br>4G62-BB000501                                |     |
| 4A                   |  | SHEET 07    |  | REV |

Tolerance : ± 0.3mm

# ITFM 5 System Label

for 944201023 & 944201024

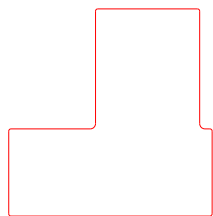

1:1

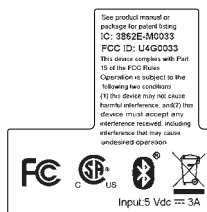

100% Size  
Print Reference

2:1

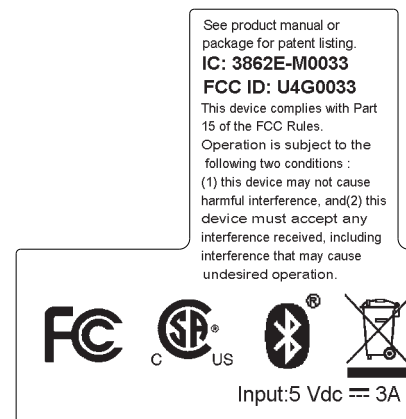

| REV | DATE | DESCRIPTION | DESIGN | D'APP |
|-----|------|-------------|--------|-------|
|     |      |             |        |       |

|      |   |
|------|---|
| SIGN |   |
| P    | M |

**Bit** 銀鑽科技股份有限公司

|                      |  |  |                                 |     |
|----------------------|--|--|---------------------------------|-----|
| :SCALE<br>1:1        |  | :UNIT<br>MM  | :MODEL<br>It1200                |     |
| :FINISH              |  |  | :MATERIAL<br>Semi-bright Silver |     |
| :DESIGN<br>Vicki-lin |  | :TITLE<br><b>System Label</b><br>for 944201023 & 944201024 |                                 |     |
| :CHK                 |  | :D'APP   |                                 |     |
| :D'APP               |  | :NVP<br>4G62-BB000501                                      |                                 |     |
| 4A                   |  | SHEET 07   | :FILENAME                       | REV |

Tolerance :  $\pm$  0.3mm



ITFM 7 Model No. label

(EdgeA+BT +1DGS W/M 6.1)

| REV | DATE | DESCRIPTION | DESIGN | D'APP |
|-----|------|-------------|--------|-------|
|     |      |             |        |       |

1:1

2:1

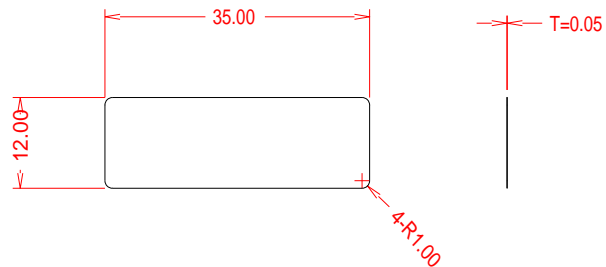

100% Size  
Print Reference

**Note:** <sup>h</sup>  
 \*Serial Number composition: SYM#####  
 where :  
 S = Manufacturing Pole (2)  
 YY = Manufacturing Year  
 M = Manufacturing Month (A,B,C,...) (A=January.....N=Dicember)  
 ##### = 5 digit Progressive Serial number for Manufacturing Pole,  
 to be resetted at every month beginning  
 \*Mod: is the product description  
 \*Manufactured: is manufacturing date  
 \*Last field is Manufacturer  
<sup>h</sup>

T : 0.07mm  
 Tolerance : ± 0.3mm

|      |   |
|------|---|
| SIGN |   |
| P    | M |

|              |                 |               |                          |
|--------------|-----------------|---------------|--------------------------|
| 銀鐳科技股份有限公司   |                 |               |                          |
| :SCALE       | :UNIT           | :MODEL        |                          |
| 1:1          | MM              | It1200 Labels |                          |
| :FINISH      | :MATERIAL       |               |                          |
| Coated paper |                 |               |                          |
| :DESIGN      | :TITLE          |               |                          |
| Vicki-lin    | Model No. label |               |                          |
|              |                 |               | (EdgeA+BT +1DGS W/M 6.1) |
| :CHK         | :N/P            |               |                          |
|              |                 |               |                          |
| :D'APP       | :FILENAME       |               | REV                      |
| 4A           |                 | SHEET? OF?    |                          |

ITFM 7 Model No. label (EdgeA +BT +2D W/M 6.1)

| REV | DATE | DESCRIPTION | DESIGN | D'APP |
|-----|------|-------------|--------|-------|
|     |      |             |        |       |

1:1

2:1

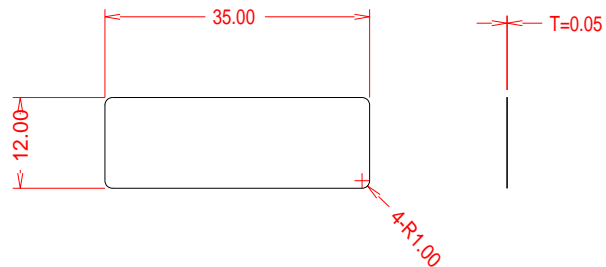

100% Size  
Print Reference

|      |  |
|------|--|
| SIGN |  |
| P    |  |
| M    |  |

**Note:** <sup>h</sup>  
 \*Serial Number composition: SYM#####  
 where :  
 S = Manufacturing Pole (2)  
 YY = Manufacturing Year  
 M = Manufacturing Month (A,B,C,...) (A=January.....N=Dicember)  
 ##### = 5 digit Progressive Serial number for Manufacturing Pole,  
 to be resetted at every month beginning  
 \*Mod: is the product description  
 \*Manufactured: is manufacturing date  
 \*Last field is Manufacturer  
<sup>h</sup>

T : 0.07mm  
 Tolerance : ± 0.3mm

|              |  |               |     |
|--------------|--|---------------|-----|
| 銀鏘科技股份有限公司   |  |               |     |
| :SCALE       | :UNIT                                      | :MODEL        |     |
| 1:1          | MM   | It1200 Labels |     |
| :FINISH      | :MATERIAL                                  |               |     |
| Coated paper |  |               |     |
| :DESIGN      | :TITLE                                     |               |     |
| Vicki-lin    | Model No. label<br>(EdgeA +BT +2D W/M 6.1) |               |     |
| :CHK         | :N/P                                       |               |     |
|              |  |               |     |
| :D'APP       | :N/P                                       |               |     |
|              |  |               |     |
| 4A           |  | SHEET? OF?    | REV |