



FCC RADIO TEST REPORT

FCC ID : U4G-SGVNRNA
Equipment : Mobile Computer/Barcode Reader
Brand Name : Datalogic
Model Name : SGVNRNA
Applicant : Datalogic S.r.l.
Via San Vitalino 13, 40012 Lippo di
Calderara di Reno (BO) – Italy
Manufacturer : Datalogic S.r.l.
Via San Vitalino 13, 40012 Lippo di
Calderara di Reno (BO) – Italy
Standard : FCC 47 CFR Part 2, 96

The product was received on Apr. 29, 2024 and testing was performed from Apr. 29, 2024 to Jul. 01, 2024. We, Sporton International Inc. EMC & Wireless Communications Laboratory, would like to declare that the tested sample has been evaluated in accordance with the test procedures and has been in compliance with the applicable technical standards.

The test results in this report apply exclusively to the tested model / sample. Without written approval from Sporton International Inc. EMC & Wireless Communications Laboratory, the test report shall not be reproduced except in full.

Louis Wu

Approved by: Louis Wu

Sporton International Inc. EMC & Wireless Communications Laboratory

No. 52, Huaya 1st Rd., Guishan Dist., Taoyuan City 333, Taiwan (R.O.C.)



Table of Contents

History of this test report3
Summary of Test Result4
1 General Description5
1.1 Product Feature of Equipment Under Test5
1.2 Modification of EUT6
1.3 Testing Site7
1.4 Applied Standards7
2 Test Configuration of Equipment Under Test8
2.1 Test Mode8
2.2 Connection Diagram of Test System9
2.3 Support Unit used in test configuration and system9
2.4 Measurement Results Explanation Example9
2.5 Frequency List of Low/Middle/High Channels10
3 Conducted Test Items11
3.1 Measuring Instruments11
3.2 Conducted Output Power Measurement12
3.3 Peak-to-Average Ratio13
3.4 EIRP14
3.5 Occupied Bandwidth15
3.6 Conducted Band Edge16
3.7 Conducted Spurious Emission17
3.8 Frequency Stability.....18
4 Radiated Test Items19
4.1 Measuring Instruments19
4.2 Test Setup.....19
4.3 Test Result of Radiated Test.....20
4.4 Radiated Spurious Emission21
5 List of Measuring Equipment22
6 Measurement Uncertainty24
Appendix A. Test Results of Conducted Test
Appendix B. Test Results of Radiated Test
Appendix C. Test Setup Photographs



History of this test report

Report No.	Version	Description	Issue Date
FG440146E	01	Initial issue of report	Jul. 02, 2024
FG440146E	02	Revise Test Mode, section 3.4.1 and Appendix A This report is an updated version, replacing the report issued on Jul. 02, 2024.	Jul. 11, 2024
FG440146E	03	Revise Appendix A This report is an updated version, replacing the report issued on Jul. 11, 2024.	Jul. 11, 2024



Summary of Test Result

Report Clause	Ref Std. Clause	Test Items	Result (PASS/FAIL)	Remark
3.2	§2.1046	Conducted Output Power	Pass	-
3.3	§96.41	Peak-to-Average Ratio	Pass	-
3.4	§96.41	Effective Isotropic Radiated Power	Pass	-
3.5	§2.1049 §96.41	Occupied Bandwidth	Pass	-
3.6	§2.1051 §96.41	Conducted Band Edge Measurement	Pass	-
3.7	§2.1051 §96.41	Conducted Spurious Emission	Pass	-
3.8	§2.1055	Frequency Stability for Temperature & Voltage	Pass	-
4.4	§2.1053 §96.41	Radiated Spurious Emission	Pass	3.95 dB under the limit at 10986.00 MHz

Conformity Assessment Condition:

1. The test results (PASS/FAIL) with all measurement uncertainty excluded are presented against the regulation limits or in accordance with the requirements stipulated by the applicant/manufacturer who shall bear all the risks of non-compliance that may potentially occur if measurement uncertainty is taken into account.
2. The measurement uncertainty please refer to each test result in the section "Measurement Uncertainty".

Disclaimer:

1. The product specifications of the EUT presented in the test report that may affect the test assessments are declared by the manufacturer who shall take full responsibility for the authenticity.
2. The purpose of different equipment name is for marketing segmentation.

Reviewed by: Wei Chen**Report Producer: Clio Lo**



1 General Description

1.1 Product Feature of Equipment Under Test

Product Feature	
General Specs GSM/WCDMA/LTE/5G NR, Bluetooth, Wi-Fi 2.4GHz 802.11b/g/n/ac/ax, Wi-Fi 5GHz 802.11a/n/ac/ax, Wi-Fi 6GHz 802.11a/ax, NFC, WPC Rx, and GNSS.	
Antenna Type WWAN: <Ant. 0>: Loop Antenna <Ant. 1>: Loop Antenna <Ant. 2+3>: Coupling monopole Antenna <Ant. 4>: PIFA Antenna <Ant. 5>: PIFA Antenna <Ant. 6>: Loop Antenna <Ant. 7>: Monopole Antenna WLAN: <Ant. 8>: Coupling monopole Antenna <Ant. 9>: Loop Antenna Bluetooth: Coupling monopole Antenna GPS/Glonass/BDS/Galileo: Coupling monopole Antenna NFC: Loop Antenna WPC Rx: Single Coil Antenna	
Sample 1	scan (Argon)
Sample 2	scan (Xenon)
HW Version	DVT2
SW Version	dl4490_gms-userdebug_1.04.001.20240520_a13_qfil_fastboot
Antenna Gain	<Ant. 4> n48: -0.43 dBi <Ant. 5> n48: -0.23 dBi <Ant. 6> n48: -0.12 dBi <Ant. 7> n48: -0.43 dBi

Remark: The EUT's information above is declared by manufacturer. Please refer to Disclaimer in report summary.



EUT Information List		
S/N	P/N	Performed Test Item
68bc07bd	944850003	Conducted Measurement EIRP
V24D00512 V24D00148	944850003 944850006	Radiated Spurious Emission

Support band and evaluated information	
Supported band	n48
Evaluated and Tested band	n48

TDD band Power Class		
	PC3	PC2
N48	V	-

1.2 Modification of EUT

No modifications made to the EUT during the testing.



1.3 Testing Site

Test Site	Sporton International Inc. EMC & Wireless Communications Laboratory
Test Site Location	No.52, Huaya 1st Rd., Guishan Dist., Taoyuan City 333, Taiwan (R.O.C.) TEL: +886-3-327-3456 FAX: +886-3-328-4978
Test Site No.	Sporton Site No. TH03-HY
Test Engineer	George Chen
Temperature (°C)	20~24
Relative Humidity (%)	50~56

Test Site	Sporton International Inc. Wensan Laboratory
Test Site Location	No.58, Aly. 75, Ln. 564, Wenhua 3rd, Rd., Guishan Dist., Taoyuan City 333010, Taiwan (R.O.C.) TEL: +886-3-327-0868 FAX: +886-3-327-0855
Test Site No.	Sporton Site No. 03CH15-HY (TAF Code: 3786)
Test Engineer	Daniel Lee, Quentin Liu and Bigshow Wang
Temperature (°C)	21~25.7
Relative Humidity (%)	48~57
Remark	The Radiated Spurious Emission test item subcontracted to Sporton International Inc. Wensan Laboratory.

Note: The test site complies with ANSI C63.4 2014 requirement.

FCC Designation No.: TW1190 and TW3786

1.4 Applied Standards

According to the specifications declared by the manufacturer, the EUT must comply with the requirements of the following standards:

- ♦ ANSI C63.26-2015
- ♦ FCC 47 CFR Part 2, 96
- ♦ FCC KDB 971168 D01 Power Meas. License Digital Systems v03r01
- ♦ FCC KDB 940660 D01 Part 96 CBRS Eqpt v03
- ♦ FCC KDB 412172 D01 Determining ERP and EIRP v01r01
- ♦ FCC KDB 414788 D01 Radiated Test Site v01r01

Remark:

1. All the test items were validated and recorded in accordance with the standards without any modification during the testing.
2. This EUT has also been tested and complied with the requirements of FCC Part 15, Subpart B, recorded in a separate test report.
3. The TAF code is not including all the FCC KDB listed without accreditation.



2 Test Configuration of Equipment Under Test

2.1 Test Mode

Antenna port conducted and radiated test items listed below are performed according to KDB 971168 D01 Power Meas. License Digital Systems v03r01 with maximum output power.

For radiated measurement, the measured emission level of the EUT was maximized by rotating the EUT on a turntable, adjusting the orientation of the EUT and EUT antenna in three orthogonal axis (X: flat, Y: portrait, Z: landscape), and adjusting the measurement antenna orientation, following C63.26 exploratory test procedures and only the worst case emissions were reported in this report.

Modulation Type	Modulation	Modulation Type	Modulation
A	DFT-s-OFDM pi/2 BPSK	N/A	N/A
B	DFT-s-OFDM QPSK	F	CP-OFDM QPSK
C	DFT-s-OFDM 16QAM	G	CP-OFDM 16QAM
D	DFT-s-OFDM 64QAM	H	CP-OFDM 64QAM
E	DFT-s-OFDM 256QAM	I	CP-OFDM 256QAM

Test Item	Modulation Type	Bandwidth	RB Size	Channel
Conducted Power	A, B, C, D, E, F, G, H, I	All	1, Half, Full	L, M, H
EIRP	A, B, C, D, E, F, G, H, I	All	1, Half, Full	L, M, H
PAR	A, B, C, D, E, F, G, H, I	20 MHz	Outer_Full	M
Bandwidth	A, F, G, H, I	All	Outer_Full	M
ACLR, Mask	A, B, C, D, E, F, G, H, I	All	Outer_1RB Outer_Full	L, M, H
CSE	B,F	Minimum	Inner_1RB	L, M, H
Frequency Stability	A,F	20 MHz	Outer_Full	M
RSE	A,F	Maximum	Inner_1RB	L, M, H

Remark:

1. Evaluated all the transmitter signal and reporting worst-case configuration among all modulation types.
2. The device is investigated from 30MHz to 10 times of fundamental signal for radiated spurious emission test under different RB size/offset and modulations in exploratory test. Subsequently, only the worst-case emissions are reported.
3. One representative bandwidth is selected to perform PAR and frequency stability.
4. 5G NR N48 support SA mode Antenna 7, MIMO mode Antenna 6+7, SRS mode Antenna 4 & 5 . Radiated Spurious Emission is full test. Conducted test items are verified and the worst case is Antenna 6, Antenna 7, Antenna 6+7. Therefore, the report only performed Antenna 6&7 test results.
5. During the RSE preliminary test, the standalone mode and charging modes (Adapter mode and WPC Rx mode) were verified. It is determined that the adapter mode is the worst case for the official test.
6. The worst-case SISO EIRP occurs in DFTs mode, while the worst-case MIMO EIRP occurs in CP mode.

2.2 Connection Diagram of Test System

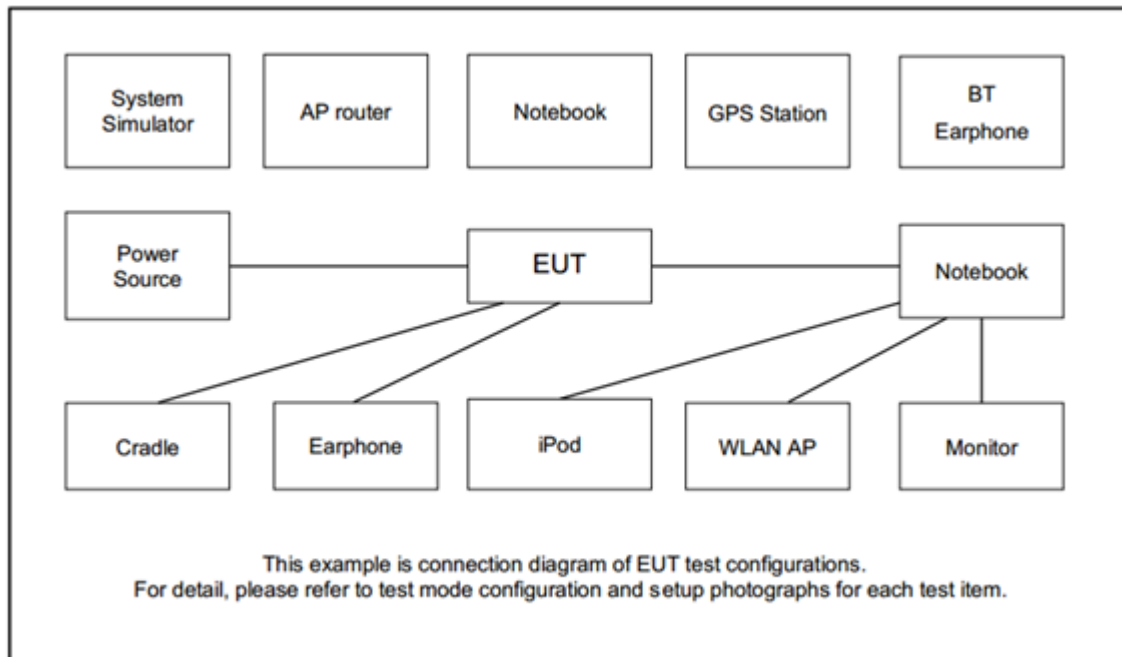

2.3 Support Unit used in test configuration and system

Item	Equipment	Brand Name	Model No.	FCC ID	Data Cable	Power Cord
1.	System Simulator	Anritsu	MT8821C	N/A	N/A	Unshielded, 1.8 m
2.	5G Wireless Test Platform	Anritsu	MT8000A	N/A	N/A	Unshielded, 1.8 m

2.4 Measurement Results Explanation Example

For all conducted test items:

The offset level is set in the spectrum analyzer to compensate the RF cable loss and attenuator factor between EUT conducted output port and spectrum analyzer. With the offset compensation, the spectrum analyzer reading level is exactly the EUT RF output level.

The spectrum analyzer offset is derived from RF cable loss and attenuator factor.

Offset = RF cable loss + attenuator factor.

Following shows an offset computation example with cable loss 4.5 dB and 10dB attenuator.

Example :

$$\begin{aligned} \text{Offset(dB)} &= \text{RF cable loss(dB)} + \text{attenuator factor(dB)} \\ &= 4.5 + 10 = 14.5 \text{ (dB)} \end{aligned}$$



2.5 Frequency List of Low/Middle/High Channels

5G NR n48 Channel and Frequency List				
BW [MHz]	Channel/Frequency(MHz)	Lowest	Middle	Highest
40	Channel	638000	641666	645332
	Frequency	3570	3624.99	3679.98
30	Channel	637668	641666	645666
	Frequency	3565.02	3624.99	3684.99
20	Channel	637334	641666	646000
	Frequency	3560.01	3624.99	3690
10	Channel	637000	641666	646332
	Frequency	3555	3624.99	3694.98

3 Conducted Test Items

3.1 Measuring Instruments

See list of measuring instruments of this test report.

3.1.1 Test Setup

3.1.2 Conducted Output Power

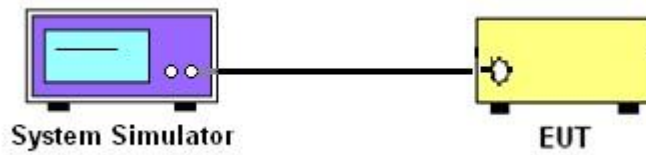

3.1.3 EIRP, Peak-to-Average Ratio, Occupied Bandwidth, Conducted Band-Edge, and Conducted Spurious Emission

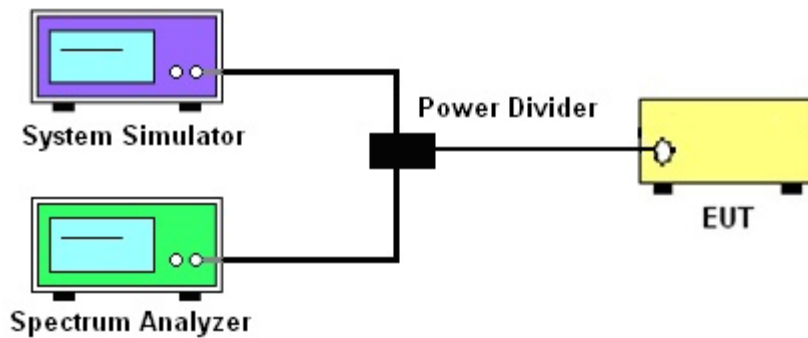

3.1.4 Frequency Stability

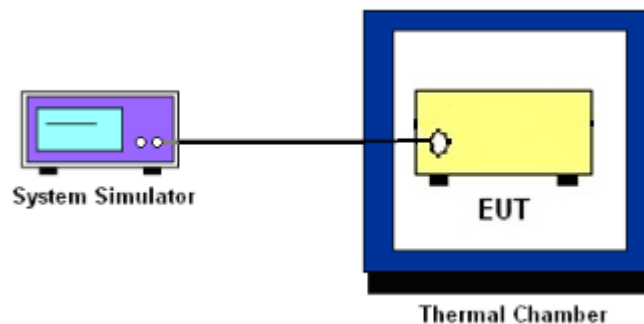

3.1.5 Test Result of Conducted Test

Please refer to Appendix A.



3.2 Conducted Output Power Measurement

3.2.1 Description of the Conducted Output Power Measurement

A base station simulator was used to establish communication with the EUT. Its parameters were set to transmit the maximum power on the EUT. The measured power in the radio frequency on the transmitter output terminals shall be reported.

3.2.2 Test Procedures

1. The transmitter output port was connected to base station.
2. Set EUT at maximum power through base station.
3. Select lowest, middle, and highest channels for each band and different modulation.
4. Measure and record the power level from the system simulator.



3.3 Peak-to-Average Ratio

3.3.1 Description of the PAR Measurement

Power Complementary Cumulative Distribution Function (CCDF) curves provide a means for characterizing the power peaks of a digitally modulated signal on a statistical basis. A CCDF curve depicts the probability of the peak signal amplitude exceeding the average power level. Most contemporary measurement instrumentation include the capability to produce CCDF curves for an input signal provided that the instrument's resolution bandwidth can be set wide enough to accommodate the entire input signal bandwidth. In measuring transmissions in this band using an average power technique, the peak-to-average ratio (PAR) of the transmission may not exceed 13 dB.

3.3.2 Test Procedures

The testing follows ANSI C63.26-2015 Section 5.2.6

1. The EUT was connected to spectrum and system simulator via a power divider.
2. Set the CCDF (Complementary Cumulative Distribution Function) option in spectrum analyzer.
3. The highest RF powers were measured and recorded the maximum PAPR level associated with a probability of 0.1 %.
4. Record the deviation as Peak to Average Ratio.



3.4 EIRP

3.4.1 Description of the EIRP Measurement

The EIRP of mobile transmitters must not exceed 23 dBm /10 megahertz for 5G NR n48.

The testing follows ANSI C63.26-2015 Section 5.2.5.5.

According to KDB 412172 D01 Power Approach,

$EIRP = PT + GT - LC$, where

PT = transmitter output power in dBm

GT = gain of the transmitting antenna in dBi

LC = signal attenuation in the connecting cable between the transmitter and antenna in dB

Device	Maximum EIRP (dBm/10 MHz)	Maximum PSD (dBm/MHz)
End User Device	23	n/a

Remark:

1. Total channel power is complied with EIRP limit 23dBm/10MHz.
2. The MIMO mode is completely uncorrelated, so the directional gain is selected the maximum gain among all antennas.

3.4.2 Test Procedures

The testing follows procedure in Section 5.2 of ANSI C63.26-2015 and KDB 940660 D01 Part 96 CBRS Eqpt v03 Section 3.2(b)(2)

Determine the EIRP by adding the effective antenna gain to the measured average conducted power level.



3.5 Occupied Bandwidth

3.5.1 Description of Occupied Bandwidth Measurement

The occupied bandwidth is the width of a frequency band such that, below the lower and above the upper frequency limits, the mean powers emitted are each equal to a specified percentage 0.5% of the total mean transmitted power.

The 26 dB emission bandwidth is defined as the frequency range between two points, one above and one below the carrier frequency, at which the spectral density of the emission is attenuated 26 dB below the maximum in-band spectral density of the modulated signal. Spectral density (power per unit bandwidth) is to be measured with a detector of resolution bandwidth equal to approximately 1.0% of the emission bandwidth.

3.5.2 Test Procedures

The testing follows ANSI C63.26-2015 Section 5.4.3 (26dB) and Section 5.4.4 (99OB)

1. The EUT was connected to spectrum analyzer and system simulator via a power divider.
2. The spectrum analyzer center frequency is set to the nominal EUT channel center frequency. The span range for the spectrum analyzer shall be between two and five times the anticipated OBW.
3. The nominal resolution bandwidth (RBW) shall be in the range of 1 to 5 % of the anticipated OBW, and the VBW shall be at least 3 times the RBW.
4. Set the detection mode to peak, and the trace mode to max hold.
5. Determine the reference value: Set the EUT to transmit a modulated signal. Allow the trace to stabilize. Set the spectrum analyzer marker to the highest level of the displayed trace.
(this is the reference value)
6. Determine the “-26 dB down amplitude” as equal to (Reference Value – X).
7. Place two markers, one at the lowest and the other at the highest frequency of the envelope of the spectral display such that each marker is at or slightly below the “-X dB down amplitude” determined in step 6. If a marker is below this “-X dB down amplitude” value it shall be placed as close as possible to this value. The OBW is the positive frequency difference between the two markers.
8. Use the 99 % power bandwidth function of the spectrum analyzer and report the measured bandwidth.



3.6 Conducted Band Edge

3.6.1 Description of Conducted Band Edge Measurement

The conducted power of any End User Device emission outside the fundamental emission (whether in or outside of the authorized band) shall not exceed -13 dBm/MHz within 0 to B megahertz (where B is the bandwidth in megahertz of the assigned channel or multiple contiguous channels of the End User Device) above the upper CBSD-assigned channel edge and within 0 to B megahertz below the lower CBSD-assigned channel edge. At all frequencies greater than B megahertz above the upper CBSD assigned channel edge and less than B megahertz below the lower CBSD-assigned channel edge, the conducted power of any End User Device emission shall not exceed -25 dBm/MHz. Notwithstanding the emission limits in this paragraph, the Adjacent Channel Leakage Ratio for End User Devices shall be at least 30 dB.

3.6.2 Test Procedures

The testing follows FCC KDB 971168 D01 v03r01 Section 6.1.

1. The EUT was connected to spectrum analyzer and system simulator via a power divider.
2. The band edges of low and high channels for the highest RF powers were measured.
3. Set RBW $\geq 1\%$ EBW in the 1MHz band immediately outside and adjacent to the band edge.
4. Beyond the 1 MHz band from the band edge, RBW=1MHz was used
5. Set spectrum analyzer with RMS detector.
6. The RF fundamental frequency should be excluded against the limit line in the operating frequency band.
7. For MIMO mode, add additional MIMO factor $10\log(\text{NTX}=2) = 3.01\text{dB}$ into the spectrum analyzer offset.

For Adjacent Channel Leakage Ratio (ACLR) measurement,

1. The Adjacent Channel Leakage Ratio (ACLR) is the ratio of the average power in the assigned aggregated channel bandwidth to the average power over the equivalent adjacent channel bandwidth.
2. The option ACLR of spectrum analyzer is used and measures the ACLR ratio by setting equivalent channel bandwidth.
3. The measured ACLR ratio shall be at least 30 dB.



3.7 Conducted Spurious Emission

3.7.1 Description of Conducted Spurious Emission Measurement

96.41 (e)(2)

The conducted power of any emissions below 3530 MHz or above 3720 MHz shall not exceed -40dBm/MHz.

3.7.2 Test Procedures

The testing follows FCC KDB 971168 D01 v03r01 Section 6.1.

1. The EUT was connected to spectrum analyzer and system simulator via a power divider.
2. The RF output of EUT was connected to the spectrum analyzer by RF cable and attenuator. The path loss was compensated to the results for each measurement.
3. The middle channel for the highest RF power within the transmitting frequency was measured.
4. The conducted spurious emission for the whole frequency range was taken.
5. Make the measurement with the spectrum analyzer's RBW = 1MHz, VBW = 3MHz.
6. Set spectrum analyzer with RMS detector.
7. Taking the record of maximum spurious emission.
8. The RF fundamental frequency should be excluded against the limit line in the operating frequency band.
9. The limit line is -40dBm/MHz.
10. For MIMO mode, add additional MIMO factor $10\log(\text{NTX}=2) = 3.01\text{dB}$ into the spectrum analyzer offset.



3.8 Frequency Stability

3.8.1 Description of Frequency Stability Measurement

The frequency stability shall be measured by variation of ambient temperature and variation of primary supply voltage to ensure that the fundamental emission stays within the authorized frequency block.

3.8.2 Test Procedures for Temperature Variation

The testing follows FCC KDB 971168 D01 v03r01 Section 9.0.

1. The EUT was set up in the thermal chamber and connected with the system simulator.
2. With power OFF, the temperature was decreased to -30°C and the EUT was stabilized before testing. Power was applied and the maximum change in frequency was recorded within one minute.
3. With power OFF, the temperature was raised in 10°C step up to 50°C. The EUT was stabilized at each step for at least half an hour. Power was applied and the maximum frequency change was recorded within one minute.

3.8.3 Test Procedures for Voltage Variation

The testing follows FCC KDB 971168 D01 v03r01 Section 9.0.

1. The EUT was placed in a temperature chamber at 25±5° C and connected with the system simulator.
2. The power supply voltage to the EUT was varied from 85% to 115% of the nominal value measured at the input to the EUT.
3. The variation in frequency was measured for the worst case.

4 Radiated Test Items

4.1 Measuring Instruments

See list of measuring instruments of this test report.

4.2 Test Setup

For radiated test below 30MHz

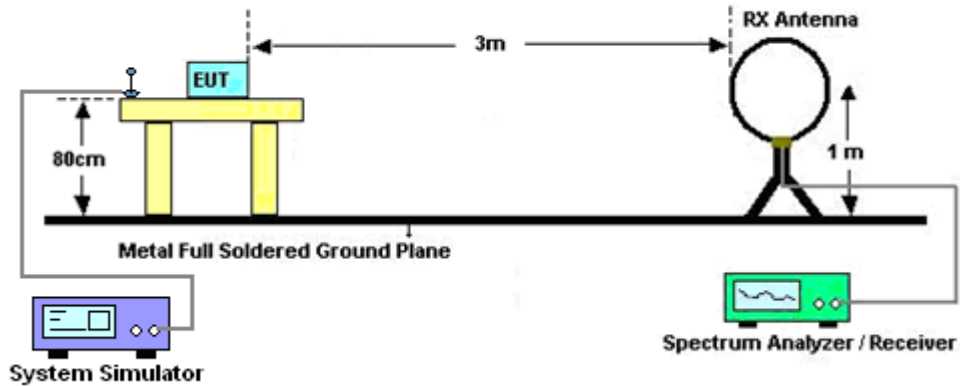

For radiated test from 30MHz to 1GHz

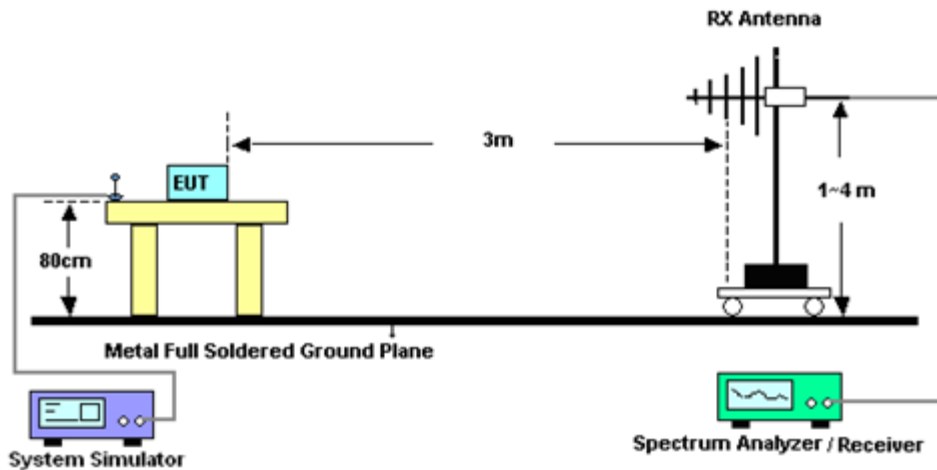

For radiated test from 1GHz to 18GHz

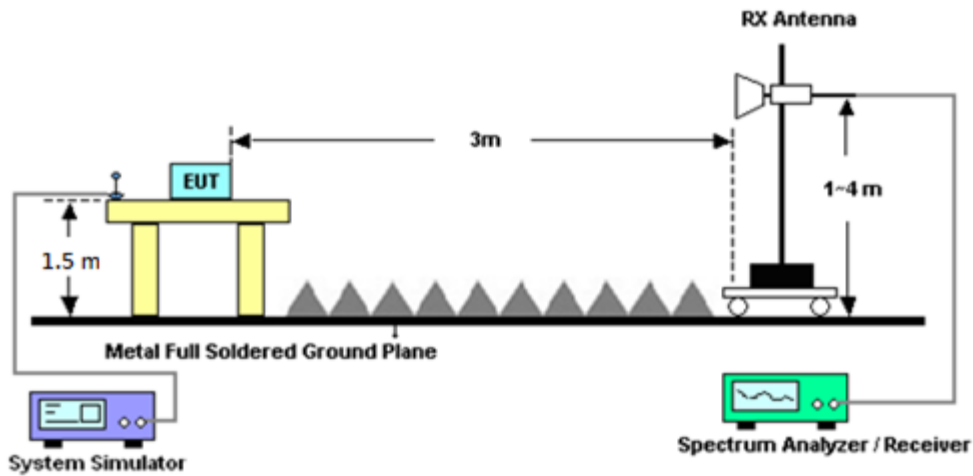

For radiated test above 18GHz

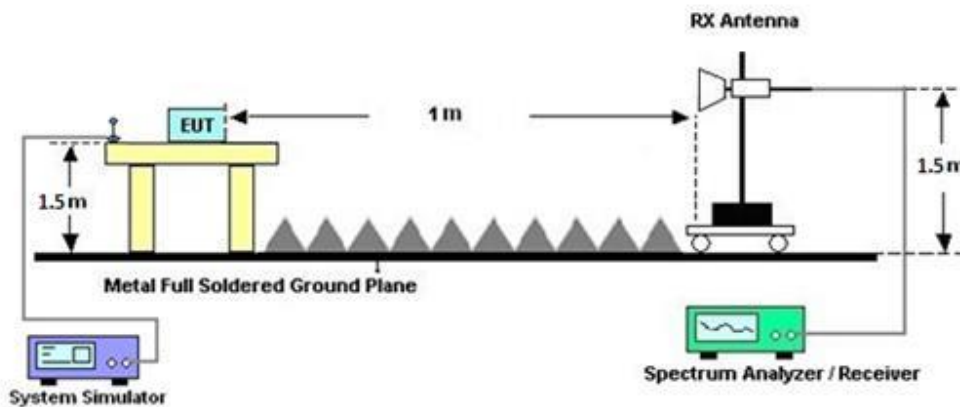

4.3 Test Result of Radiated Test

Please refer to Appendix B.

Note:

The low frequency, which started from 9 kHz to 30MHz, was pre-scanned and the result which was 20dB lower than the limit line was not reported.

There is adequate comparison measurement of both open-field test site and alternative test site - semi-Anechoic chamber according to 414788 D01 Radiated Test Site v01r01, and the result came out very similar.



4.4 Radiated Spurious Emission

4.4.1 Description of Radiated Spurious Emission

The radiated spurious emission was measured by substitution method according to ANSI C63.26-2015. The power of any emission outside of the authorized operating frequency ranges must be attenuated below the transmitter power (P) by a factor of at least -40dBm / MHz
The spectrum is scanned from 30 MHz up to a frequency including its 10th harmonic.

4.4.2 Test Procedures

The testing follows FCC KDB 971168 D01 v03r01 Section 7 and ANSI C63.26-2015 section 5.5.4 Radiated measurement using the field strength method.

1. The EUT was placed on a turntable with 0.8 meter for frequency below 1GHz and 1.5 meter for frequency above 1GHz respectively above ground.
2. The EUT was set 3 meters from the receiving antenna mounted on the antenna tower.
3. The table was rotated 360 degrees to determine the position of the highest spurious emission.
4. The height of the receiving antenna is varied between 1m to 4m to search the maximum spurious emission for both horizontal and vertical polarizations.
5. During the measurement, the system simulator parameters were set to force the EUT transmitting at maximum output power.
6. Make the measurement with the spectrum analyzer's RBW = 1MHz, VBW = 3MHz, taking the record of maximum spurious emission.
7. To convert spectrum reading E(dBuV/m) to EIRP(dBm)
$$\text{EIRP(dBm)} = \text{Level (dBuV/m)} + 20\log(d) - 104.77,$$
where d is the distance at which field strength limit is specified in the rules
8. Field Strength Level (dBm) = Spectrum Reading (dBm) + Antenna Factor + Cable Loss + Read Level - Preamp Factor.
9. ERP (dBm) = EIRP (dBm) - 2.15
10. The RF fundamental frequency should be excluded against the limit line in the operating frequency band.



5 List of Measuring Equipment

Instrument	Brand Name	Model No.	Serial No.	Characteristics	Calibration Date	Test Date	Due Date	Remark
Loop Antenna	Rohde & Schwarz	HFH2-Z2	100488	9 kHz~30 MHz	Sep. 12, 2023	May 07, 2024~ Jun. 11, 2024	Sep. 11, 2024	Radiation (03CH15-HY)
Bilog Antenna	TESEQ	CBL 6111D & 00800N1D01N-06	41912 & 05	30MHz~1GHz	Feb. 04, 2024	May 07, 2024~ Jun. 11, 2024	Feb. 03, 2025	Radiation (03CH15-HY)
Horn Antenna	SCHWARZBECK	BBHA 9120 D	9120D-02294	1GHz~18GHz	Jun. 30, 2023	May 07, 2024~ May 23, 2024	Jun. 29, 2024	Radiation (03CH15-HY)
Horn Antenna	SCHWARZBECK	BBHA 9120 D	9120D-02038	1GHz~18GHz	Jul. 31, 2023	May 24, 2024~ Jun. 11, 2024	Jul. 30, 2024	Radiation (03CH15-HY)
SHF-EHF Horn Antenna	SCHWARZBECK	BBHA 9170	1223	18GHz~40GHz	Jul. 10, 2023	May 07, 2024~ May 24, 2024	Jul. 09, 2024	Radiation (03CH15-HY)
SHF-EHF Horn Antenna	SCHWARZBECK	BBHA 9170	993	18GHz~40GHz	Nov. 24, 2023	May 07, 2024~ Jun. 11, 2024	Nov. 23, 2024	Radiation (03CH15-HY)
Amplifier	SONOMA	310N	363440	9kHz~1GHz	Dec. 25, 2023	May 07, 2024~ Jun. 11, 2024	Dec. 24, 2024	Radiation (03CH15-HY)
Preamplifier	EMEC	EM01G18G	060837	1GHz~18GHz	Feb. 15, 2024	May 07, 2024~ Jun. 11, 2024	Feb. 14, 2025	Radiation (03CH15-HY)
Preamplifier	EM Electronics	EM01G18G	060802	1GHz~18GHz	Feb. 29, 2024	May 07, 2024~ Jun. 11, 2024	Feb. 28, 2025	Radiation (03CH15-HY)
Preamplifier	EMEC	EM18G40G	060715	18GHz~40GHz	Dec. 07, 2023	May 07, 2024~ Jun. 11, 2024	Dec. 06, 2024	Radiation (03CH15-HY)
EMI Test Receiver	Keysight	N9038A (MXE)	MY53290045	20MHz~8.4GHz	Oct. 06, 2023	May 07, 2024~ Jun. 11, 2024	Oct. 05, 2024	Radiation (03CH15-HY)
Spectrum Analyzer	Keysight	N9010B	MY60241058	10Hz~44GHz	Jul. 06, 2023	May 07, 2024~ Jun. 11, 2024	Jul. 05, 2024	Radiation (03CH15-HY)
Antenna Mast	ChainTek	MBS-520-1	N/A	1m~4m	N/A	May 07, 2024~ Jun. 11, 2024	N/A	Radiation (03CH15-HY)
Turn Table	ChainTek	T-200-S-1	N/A	0~360 Degree	N/A	May 07, 2024~ Jun. 11, 2024	N/A	Radiation (03CH15-HY)
Software	Audix	E3_V9_230621	RK-002394	N/A	N/A	May 07, 2024~ Jun. 11, 2024	N/A	Radiation (03CH15-HY)
RF Cable	HUBER + SUHNER	SUCOFLEX 104, 102E	MY582185/4,5 19228/2,8039 50/2	N/A	Jun. 13, 2023	May 07, 2024~ Jun. 11, 2024	Jun. 12, 2024	Radiation (03CH15-HY)
RF Cable	HUBER + SUHNER	SUCOFLEX 102	804011/2,804 012/2	18-40G	Jan. 02, 2024	May 07, 2024~ Jun. 11, 2024	Jan. 01, 2025	Radiation (03CH15-HY)
Filter	Wainwright	WHKX12-1080-12 00-15000-60ST	SN5	1.2GHz High Pass Filter	Jun. 14, 2023	May 07, 2024~ Jun. 11, 2024	Jun. 13, 2024	Radiation (03CH15-HY)
Filter	Wainwright	WHKX12-2700-30 00-18000-60ST	SN4	3GHz High Pass Filter	Jun. 14, 2023	May 07, 2024~ Jun. 11, 2024	Jun. 13, 2024	Radiation (03CH15-HY)
Filter	Wainwright	WHKX12-2700-30 00-18000-60ST	SN4	3GHz High Pass Filter	Jun. 14, 2023	May 07, 2024~ Jun. 11, 2024	Jun. 13, 2024	Radiation (03CH15-HY)
Hygrometer	TECEPEL	DTM-302	SN4	N/A	Jul. 26, 2023	May 07, 2024~ Jun. 11, 2024	Jul. 25, 2024	Radiation (03CH15-HY)



Instrument	Brand Name	Model No.	Serial No.	Characteristics	Calibration Date	Test Date	Due Date	Remark
DC Power Supply	GW Instek	GPE2323	GEU871221	0V~64V ;0A~6A	Apr. 09, 2024	Apr. 29, 2024~ Jul. 01, 2024	Apr. 08, 2025	Conducted (TH03-HY)
Signal Analyzer	Rohde & Schwarz	FSV3044	101544	10Hz~44GHz	Jul. 25, 2023	Apr. 29, 2024~ Jul. 01, 2024	Jul. 24, 2024	Conducted (TH03-HY)
Temperature Chamber	ESPEC	SH-641	92013720	-40°C ~90°C	Sep. 04, 2023	Apr. 29, 2024~ Jun. 28, 2024	Sep. 03, 2024	Conducted (TH03-HY)
Base Station (Measure)	Anritsu	MT8821C	6261849015	LTE	Nov. 17, 2023	Apr. 29, 2024~ Jun. 28, 2024	Nov. 16, 2024	Conducted (TH03-HY)
Base Station (Measure)	Anritsu	MT8000A	6262186342	FR1	Nov. 14, 2023	Apr. 29, 2024~ Jul. 01, 2024	Nov. 13, 2024	Conducted (TH03-HY)
Coupler	MVE	MVE-4816-10	A400024	NA	Jul. 01, 2023	Apr. 29, 2024~ Jun. 28, 2024	Jun. 30, 2024	Conducted (TH03-HY)
Hygrometer	Testo	608-H1	34893241	NA	Mar. 14, 2024	Apr. 29, 2024~ Jul. 01, 2024	Mar. 13, 2025	Conducted (TH03-HY)
Signal Analyzer	Rohde & Schwarz	FSW43	101456	RBW 50MHz	Feb. 19, 2024	Apr. 29, 2024~ Jun. 28, 2024	Feb. 18, 2025	Conducted (TH03-HY)
Power divider	Anritsu	K241C	2143398	9KHz~40GHz	Jun. 13, 2024	Jun. 28, 2024~ Jul. 01, 2024	Jun. 12, 2025	Conducted (TH03-HY)



6 Measurement Uncertainty

Uncertainty of Radiated Emission Measurement (30 MHz ~ 1000 MHz)

Measuring Uncertainty for a Level of Confidence of 95% ($U = 2Uc(y)$)	3.02 dB
-------------------------------------------------------------------------	---------

Uncertainty of Radiated Emission Measurement (1 GHz ~ 18 GHz)

Measuring Uncertainty for a Level of Confidence of 95% ($U = 2Uc(y)$)	3.57 dB
-------------------------------------------------------------------------	---------

Uncertainty of Radiated Emission Measurement (18 GHz ~ 40 GHz)

Measuring Uncertainty for a Level of Confidence of 95% ($U = 2Uc(y)$)	3.97 dB
-------------------------------------------------------------------------	---------



Appendix A. Test Results of Conducted Test

Conducted Output Power(Average power) and EIRP

<SISO Mode>

NR n48 Maximum Average Power [dBm] (GT - LC = -0.23 dB)								
BW [MHz]	RB Size	RB Offset	Mod	Lowest	Middle	Highest	EIRP (dBm)	EIRP(W)
10	1	1	PI/2 BPSK	21.61	22.05	21.49	22.02	0.1592
10	1	22		21.47	22.04	21.69		
10	12	6		21.62	22.25	21.65		
10	1	0		21.06	21.56	21.00		
10	1	23		21.00	21.58	21.03		
10	24	0		21.09	21.75	21.09		
10	1	1	QPSK	21.58	22.03	21.52	21.09	0.1285
10	1	22		21.45	22.11	21.52		
10	12	6		21.59	22.17	21.60		
10	1	0		20.65	21.13	20.48		
10	1	23		20.42	21.22	20.51		
10	24	0		20.61	21.27	20.65		
10	1	1	16-QAM	20.68	21.32	20.73	21.09	0.1285
10	1	1	64-QAM	19.17	19.65	19.05		
10	1	1	256-QAM	16.84	17.36	16.79		
Limit	EIRP < 23dBm/10MHz			Result			Pass	

Total EIRP power is less than partial EIRP limit 23 dBm/10MHz.

NR n48 Maximum Average Power [dBm] (GT - LC = -0.23 dB)								
BW [MHz]	RB Size	RB Offset	Mod	Lowest	Middle	Highest	EIRP (dBm)	EIRP(W)
20	1	1	PI/2 BPSK	17.60	21.93	21.47	22.06	0.1607
20	1	49		21.60	22.15	17.49		
20	25	12		21.69	22.29	21.67		
20	1	0		17.55	21.51	21.08		
20	1	50		21.01	21.72	17.59		
20	50	0		17.53	21.70	17.61		
20	1	1	QPSK	17.54	21.98	21.38	20.81	0.1205
20	1	49		21.61	22.07	17.54		
20	25	12		21.63	22.22	21.57		
20	1	0		17.46	20.93	20.42		
20	1	50		20.63	21.33	17.40		
20	50	0		17.70	21.23	17.55		
20	1	1	16-QAM	16.76	21.04	20.42	20.81	0.1205
20	1	1	64-QAM	16.64	19.53	19.06		
20	1	1	256-QAM	16.89	17.29	16.82		
Limit	EIRP < 23dBm/10MHz			Result			Pass	

Total EIRP power is less than partial EIRP limit 23 dBm/10MHz.



NR n48 Maximum Average Power [dBm] (GT - LC = -0.23 dB)										
BW [MHz]	RB Size	RB Offset	Mod	Lowest	Middle	Highest	EIRP (dBm)	EIRP(W)		
30	1	1	PI/2 BPSK	11.30	18.11	11.31	22.06	0.1607		
30	1	76		11.16	18.08	11.00				
30	36	18		11.17	22.19	21.72				
30	1	0		11.23	17.96	11.33				
30	1	77		11.11	18.13	11.02				
30	75	0		11.20	18.30	11.27				
30	1	1	QPSK	11.25	18.06	11.27			18.14	0.0652
30	1	76		11.08	18.07	10.97				
30	36	18		11.17	22.29	21.64				
30	1	0		11.25	18.19	11.25				
30	1	77		11.10	18.06	11.05				
30	75	0		11.22	18.25	11.20				
30	1	1	16-QAM	10.89	18.37	10.91	18.14	0.0652		
30	1	1	64-QAM	10.90	18.24	10.86				
30	1	1	256-QAM	10.51	17.47	10.55				
Limit	EIRP < 23dBm/10MHz			Result			Pass			

Total EIRP power is less than partial EIRP limit 23 dBm/10MHz.

NR n48 Maximum Average Power [dBm] (GT - LC = -0.23 dB)										
BW [MHz]	RB Size	RB Offset	Mod	Lowest	Middle	Highest	EIRP (dBm)	EIRP(W)		
40	1	1	PI/2 BPSK	11.30	18.02	11.29	22.01	0.1589		
40	1	104		11.36	18.19	11.09				
40	50	25		11.23	22.23	11.16				
40	1	0		11.21	17.99	11.32				
40	1	105		11.41	18.23	11.07				
40	100	0		11.22	17.77	11.17				
40	1	1	QPSK	11.19	17.97	11.34			17.94	0.0622
40	1	104		11.38	18.15	11.06				
40	50	25		11.15	22.24	11.14				
40	1	0		11.25	18.05	11.34				
40	1	105		11.41	18.30	11.08				
40	100	0		11.19	17.74	11.19				
40	1	1	16-QAM	10.80	18.17	10.92	17.94	0.0622		
40	1	1	64-QAM	10.76	18.06	10.87				
40	1	1	256-QAM	10.55	17.32	10.55				
Limit	EIRP < 23dBm/10MHz			Result			Pass			

Total EIRP power is less than partial EIRP limit 23 dBm/10MHz.



<MIMO Mode>

Part96 NR n48 Maximum Average Power [dBm], DG = -0.12 dBi														
BW	RB	RB	Mod	Antenna 6			Antenna 7			Combine			EIRP	EIRP
(MHz)	Size	Offset		Lowest	Middle	Highest	Lowest	Middle	Highest	Lowest	Middle	Highest	(dBm)	(W)
10	1	1	QPSK	18.15	19.11	18.17	17.33	17.82	17.26	20.77	21.52	20.75	21.47	0.1403
10	1	22		18.31	19.12	18.34	17.27	17.85	17.34	20.83	21.54	20.88		
10	12	6		18.38	19.17	18.39	17.32	17.89	17.21	20.89	21.59	20.85		
10	1	0		16.80	17.54	16.81	15.79	16.35	15.71	19.33	20.00	19.31		
10	1	23		16.82	17.52	16.76	15.70	16.25	15.70	19.31	19.94	19.27		
10	24	0		16.80	17.62	16.89	15.71	16.41	15.73	19.30	20.07	19.36		
10	1	1	16-QAM	17.70	18.49	17.74	16.86	17.48	16.83	20.31	21.02	20.32	20.90	0.1230
10	1	1	64-QAM	16.16	16.92	16.16	15.41	15.82	15.31	18.81	19.42	18.77		
10	1	1	256-QAM	13.25	14.04	13.34	12.41	12.85	12.17	15.86	16.50	15.80		
Limit	EIRP < 23dBm/10MHz			Result									Pass	

Total EIRP power is less than partial EIRP limit 23 dBm/10MHz.

Part96 NR n48 Maximum Average Power [dBm], DG = -0.12 dBi														
BW	RB	RB	Mod	Antenna 6			Antenna 7			Combine			EIRP	EIRP
(MHz)	Size	Offset		Lowest	Middle	Highest	Lowest	Middle	Highest	Lowest	Middle	Highest	(dBm)	(W)
20	1	1	QPSK	13.76	19.01	18.19	12.80	17.72	17.14	16.32	21.42	20.71	21.50	0.1413
20	1	49		18.46	19.01	13.78	17.36	17.94	12.61	20.96	21.52	16.24		
20	25	12		18.59	19.22	18.35	17.24	17.90	17.13	20.98	21.62	20.79		
20	1	0		13.66	17.52	16.70	12.89	16.27	15.74	16.30	19.95	19.26		
20	1	50		17.17	17.54	13.64	15.89	16.54	12.67	19.59	20.08	16.19		
20	51	0		13.99	17.64	13.85	12.81	16.38	12.67	16.45	20.07	16.31		
20	1	1	16-QAM	13.87	18.43	17.77	12.96	17.27	16.74	16.45	20.90	20.30	20.78	0.1197
20	1	1	64-QAM	13.71	16.80	16.21	12.93	15.73	15.27	16.35	19.31	18.78		
20	1	1	256-QAM	13.34	13.94	13.14	12.42	12.84	12.25	15.91	16.44	15.73		
Limit	EIRP < 23dBm/10MHz			Result									Pass	

Total EIRP power is less than partial EIRP limit 23 dBm/10MHz.

Part96 NR n48 Maximum Average Power [dBm], DG = -0.12 dBi														
BW	RB	RB	Mod	Antenna 6			Antenna 7			Combine			EIRP	EIRP
(MHz)	Size	Offset		Lowest	Middle	Highest	Lowest	Middle	Highest	Lowest	Middle	Highest	(dBm)	(W)
30	1	1	QPSK	8.25	16.59	8.46	7.38	15.29	7.37	10.85	19.00	10.96	21.51	0.1416
30	1	76		8.39	16.82	8.15	7.32	15.28	7.23	10.90	19.13	10.72		
30	39	19		8.37	19.28	8.35	7.18	17.85	7.10	10.83	21.63	10.78		
30	1	0		8.26	16.56	8.35	7.46	15.43	7.37	10.89	19.04	10.90		
30	1	77		8.43	16.48	8.14	7.27	15.44	7.20	10.90	19.00	10.71		
30	78	0		8.36	16.66	8.34	7.20	15.36	7.10	10.83	19.07	10.77		
30	1	1	16-QAM	8.47	16.56	8.56	7.46	15.25	7.53	11.00	18.96	11.09	18.88	0.0773
30	1	1	64-QAM	8.26	16.47	8.36	7.50	15.45	7.39	10.91	19.00	10.91		
30	1	1	256-QAM	8.33	14.06	8.46	7.51	12.88	7.44	10.95	16.52	10.99		
Limit	EIRP < 23dBm/10MHz			Result									Pass	

Total EIRP power is less than partial EIRP limit 23 dBm/10MHz.

Part96 NR n48 Maximum Average Power [dBm], DG = -0.12 dBi														
BW	RB	RB	Mod	Antenna 6			Antenna 7			Combine			EIRP	EIRP
(MHz)	Size	Offset		Lowest	Middle	Highest	Lowest	Middle	Highest	Lowest	Middle	Highest	(dBm)	(W)
40	1	1	QPSK	8.31	16.44	8.40	7.28	15.42	7.41	10.84	18.97	10.94	21.43	0.1390
40	1	104		8.81	16.39	8.09	7.53	15.40	7.25	11.23	18.93	10.70		
40	53	26		8.52	19.17	8.20	7.24	17.80	7.13	10.94	21.55	10.71		
40	1	0		8.37	16.41	8.58	7.37	15.25	7.38	10.91	18.88	11.03		
40	1	105		8.54	16.65	8.24	7.52	15.44	7.16	11.07	19.10	10.74		
40	106	0		8.53	16.09	8.23	7.29	14.87	7.16	10.96	18.53	10.74		
40	1	1	16-QAM	8.22	16.35	8.31	7.44	15.34	7.47	10.86	18.88	10.92	18.88	0.0773
40	1	1	64-QAM	8.29	16.43	8.47	7.46	15.51	7.49	10.91	19.00	11.02		
40	1	1	256-QAM	8.40	13.94	8.51	7.49	12.68	7.52	10.98	16.37	11.05		
Limit	EIRP < 23dBm/10MHz			Result									Pass	

Total EIRP power is less than partial EIRP limit 23 dBm/10MHz.



FR1 n48

<SISO Mode>

Peak-to-Average Ratio

Mode	FR1 n48 / 20MHz / DFT-S OFDM				
Mod.	PI/2 BPSK	QPSK	16QAM	64QAM	Limit: 13dB
RB Size	Full RB	Full RB	Full RB	Full RB	Result
Middle CH	4.34	4.98	5.98	6.22	PASS
Mode	FR1 n48 / 20MHz / DFT-S OFDM				
Mod.	256QAM				Limit: 13dB
RB Size	Full RB				Result
Middle CH	6.66				PASS



FR1 n48 / 20MHz / DFT-S OFDM / Middle Channel / Full RB

PI/2 BPSK

QPSK

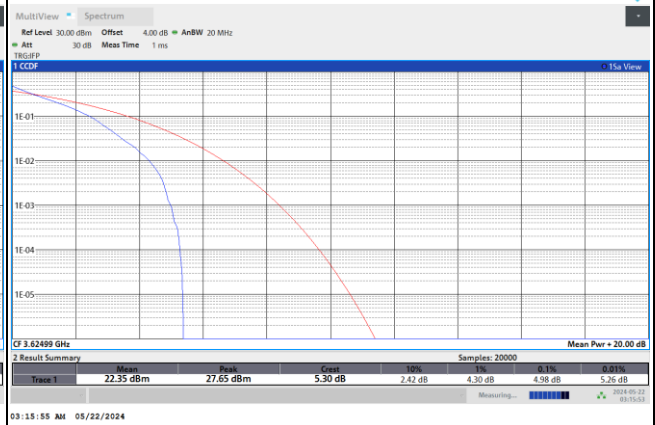
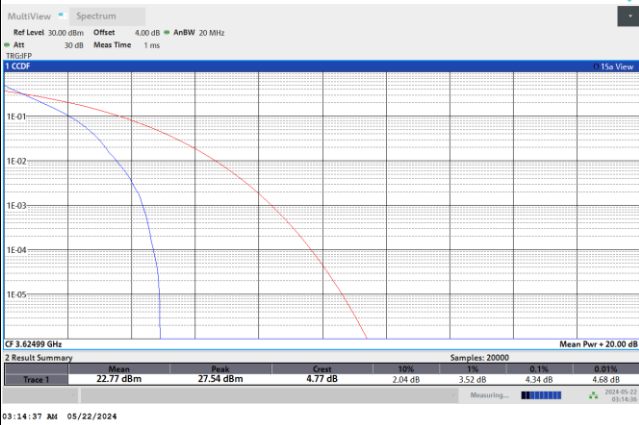

16QAM

64QAM

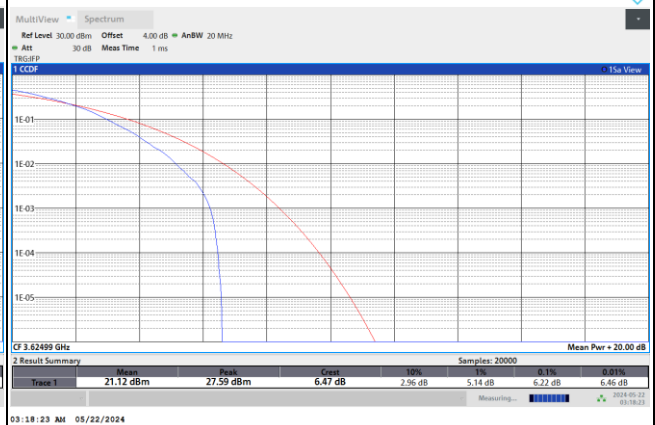
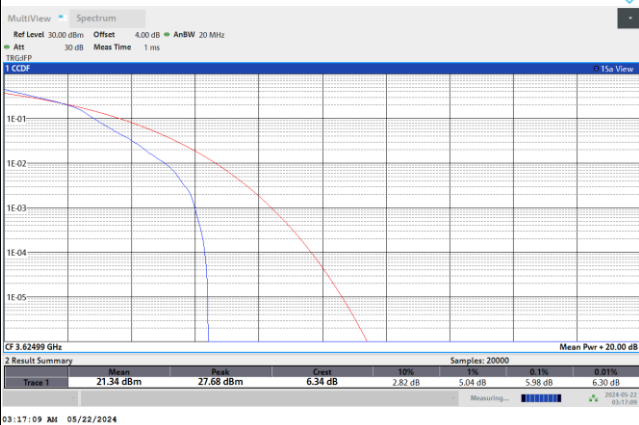

256QAM

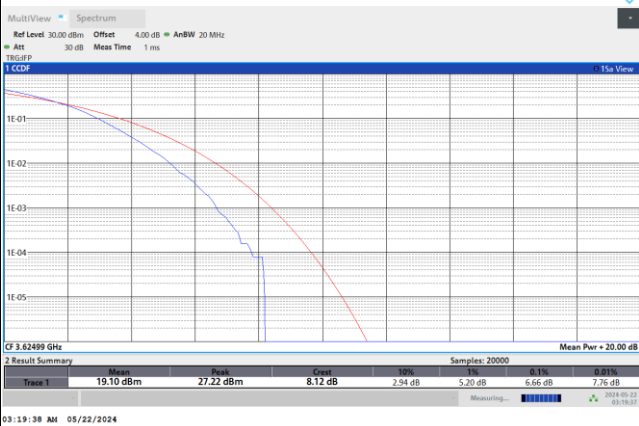



26dB Bandwidth

Mode	FR1 n48 : 26dB BW(MHz) / DFT-S OFDM							
BW	10MHz	20MHz	30MHz	40MHz	20MHz			
Mod.	PI/2 BPSK	PI/2 BPSK	PI/2 BPSK	PI/2 BPSK	PI/2 BPSK			
Middle CH	10.11	20.43	31.35	40.09	20.43			

Mode	FR1 n48 : 26dB BW(MHz) / CP OFDM							
BW	10MHz		20MHz		30MHz		40MHz	
Mod.	QPSK	16QAM	QPSK	16QAM	QPSK	16QAM	QPSK	16QAM
Middle CH	10.62	10.42	23.77	22.39	31.34	32.50	41.05	42.87
Mod.	64QAM	256QAM	64QAM	256QAM	64QAM	256QAM	64QAM	256QAM
Middle CH	11.92	10.27	20.46	20.38	32.31	32.31	41.05	42.82



FR1 n48 / 10MHz / DFT-S OFDM / Middle Channel / Full RB

PI/2 BPSK

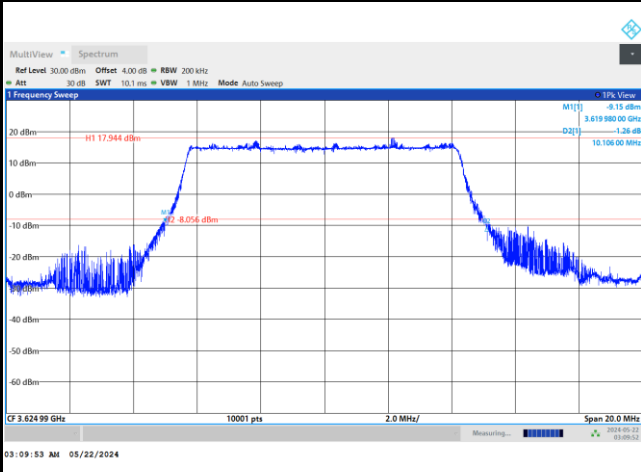

FR1 n48 / 10MHz / CP OFDM / Middle Channel / Full RB

QPSK

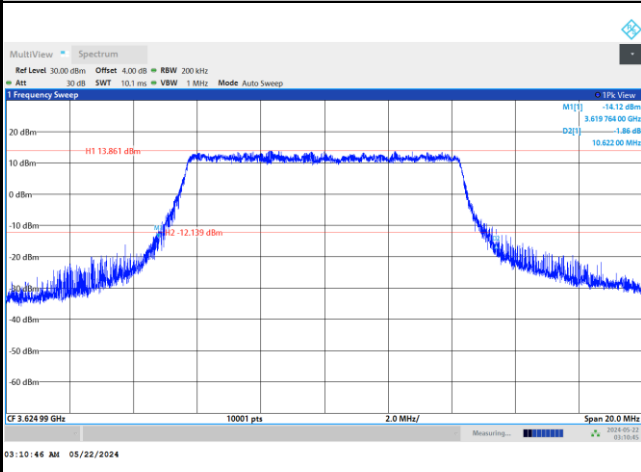

16QAM

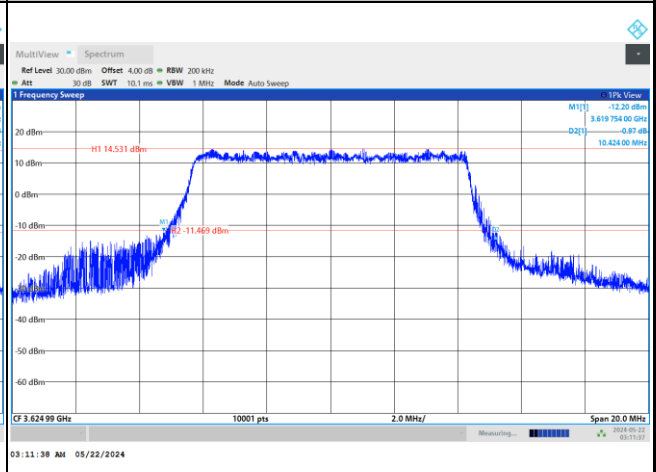

64QAM

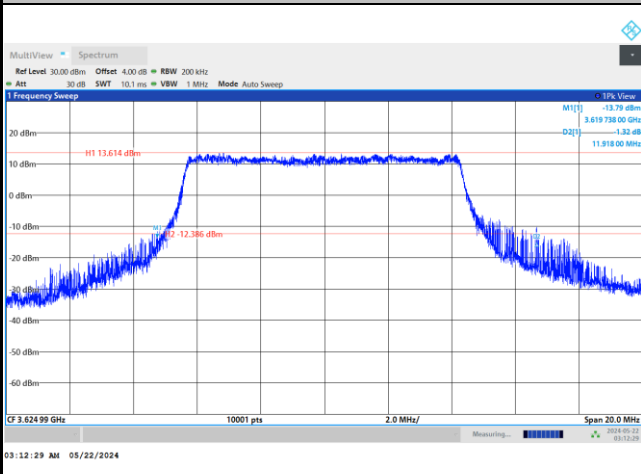

256QAM

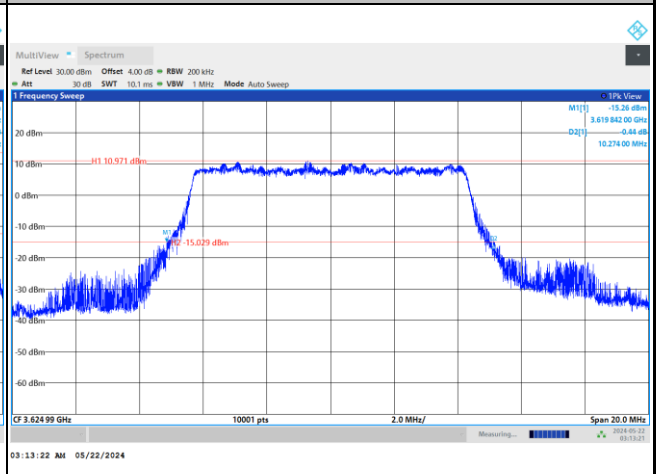



FR1 n48 / 20MHz / DFT-S OFDM / Middle Channel / Full RB

PI/2 BPSK

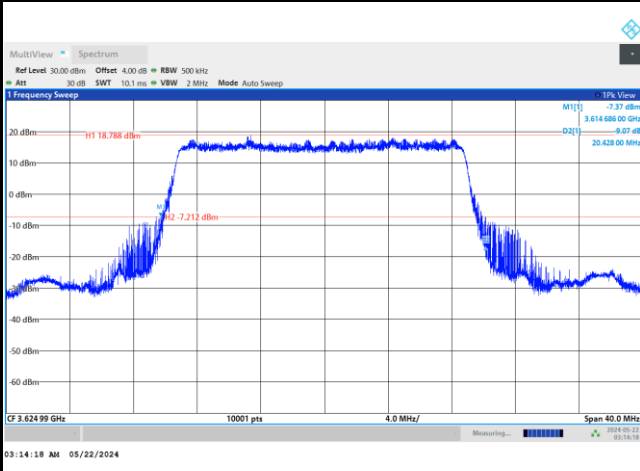

FR1 n48 / 20MHz / CP OFDM / Middle Channel / Full RB

QPSK

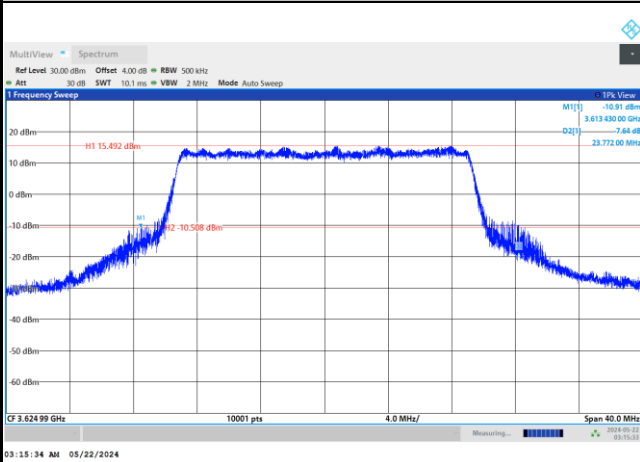

16QAM

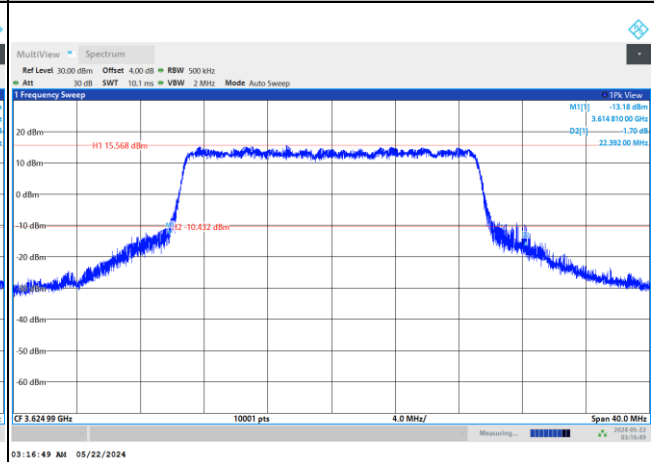

64QAM

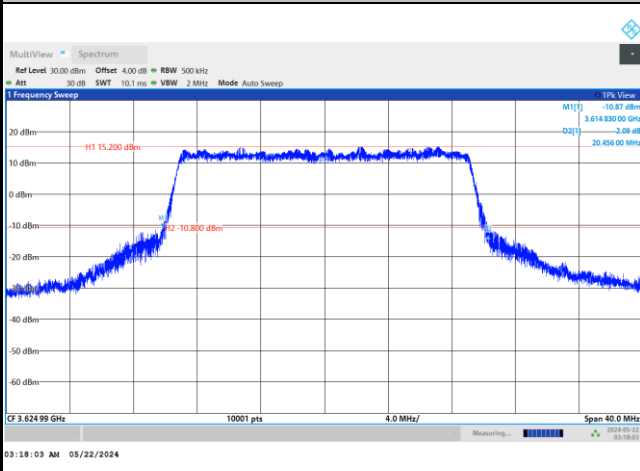

256QAM

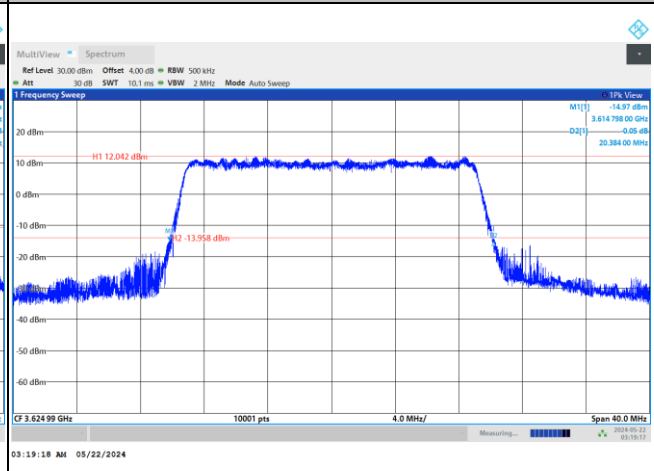



FR1 n48 / 30MHz / DFT-S OFDM / Middle Channel / Full RB

PI/2 BPSK

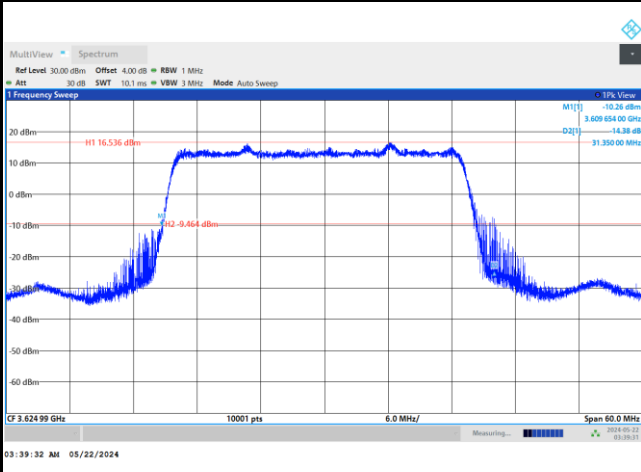

FR1 n48 / 30MHz / CP OFDM / Middle Channel / Full RB

QPSK

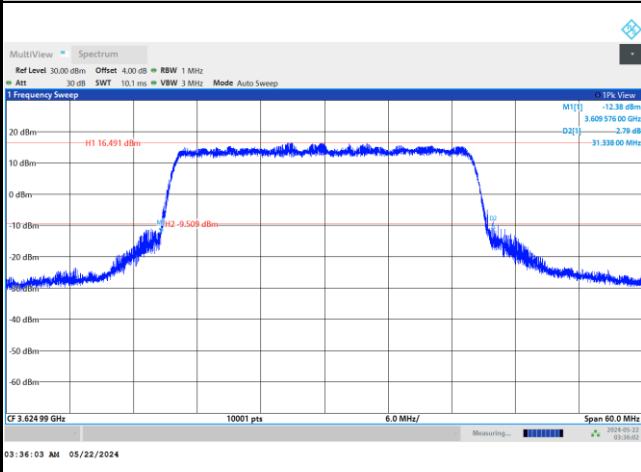

16QAM

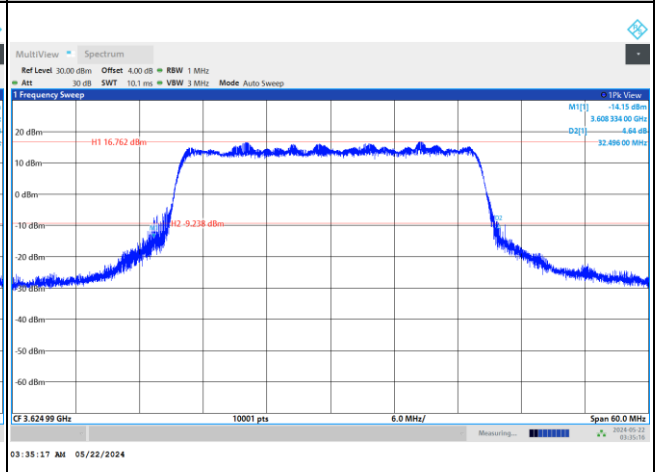

64QAM

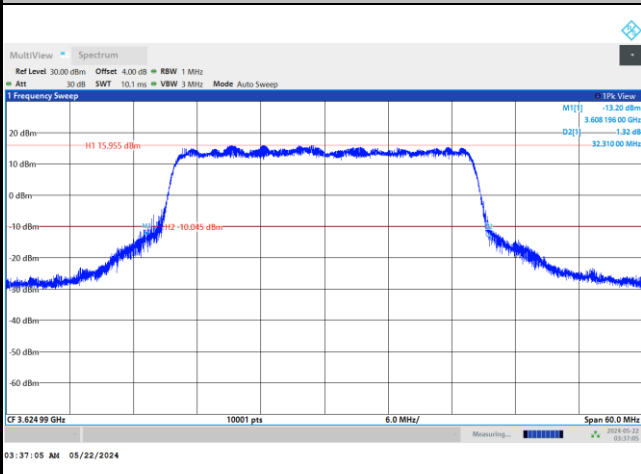

256QAM

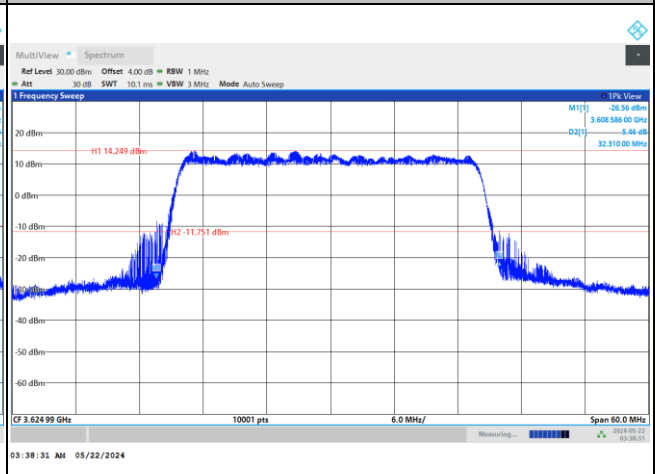



Occupied Bandwidth

Mode	FR1 n48 : OB BW(MHz) / DFT-S OFDM							
BW	10MHz	20MHz	30MHz	40MHz				
Mod.	PI/2 BPSK	PI/2 BPSK	PI/2 BPSK	PI/2 BPSK				
Middle CH	8.65	18.02	27.22	36.06				

Mode	FR1 n48 : OB BW(MHz) / CP OFDM							
BW	10MHz		20MHz		30MHz		40MHz	
Mod.	QPSK	16QAM	QPSK	16QAM	QPSK	16QAM	QPSK	16QAM
Middle CH	8.68	8.69	18.38	18.43	28.20	28.09	38.05	38.20
Mod.	64QAM	256QAM	64QAM	256QAM	64QAM	256QAM	64QAM	256QAM
Middle CH	8.72	8.69	18.35	18.41	28.12	28.17	38.08	38.25



FR1 n48 / 10MHz / DFT-S OFDM / Middle Channel / Full RB

PI/2 BPSK

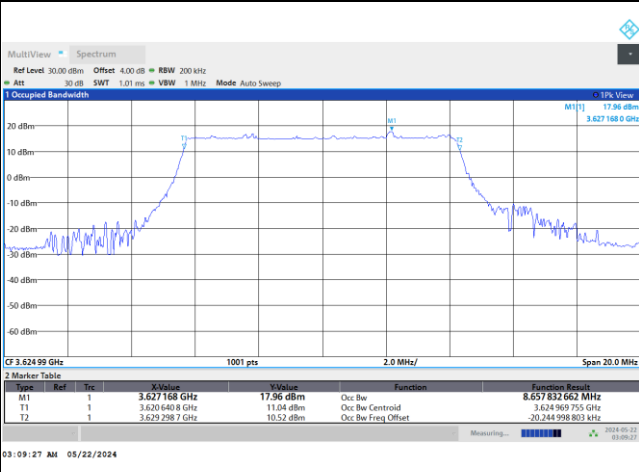

FR1 n48 / 10MHz / CP OFDM / Middle Channel / Full RB

QPSK

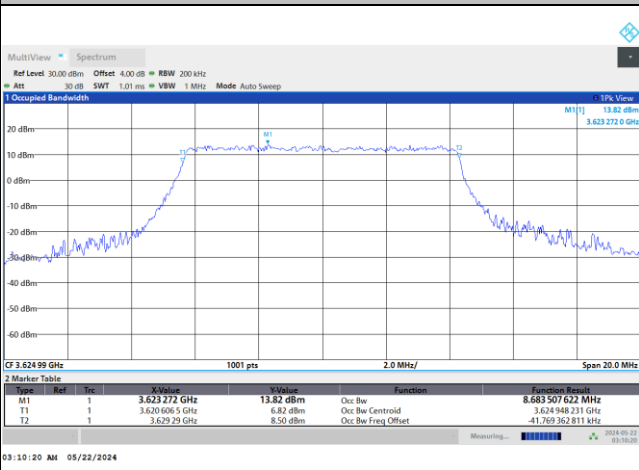

16QAM

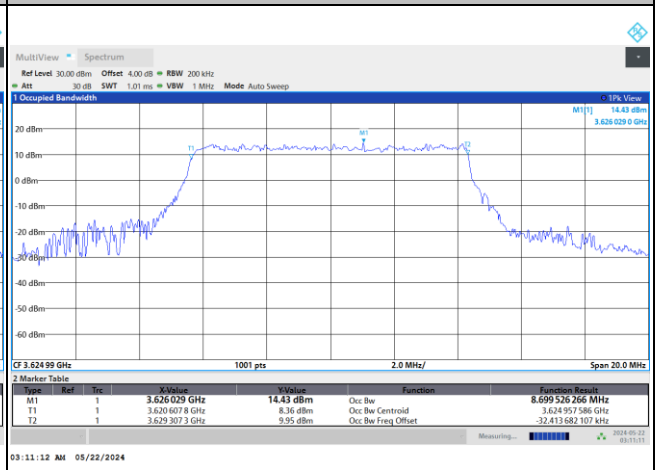

64QAM

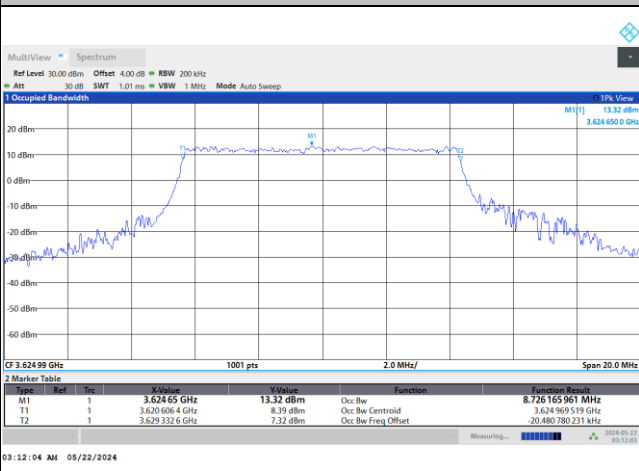

256QAM

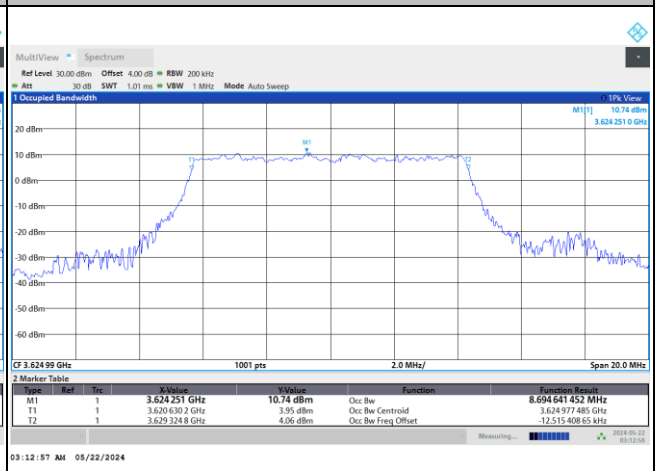



FR1 n48 / 20MHz / DFT-S OFDM / Middle Channel / Full RB

PI/2 BPSK

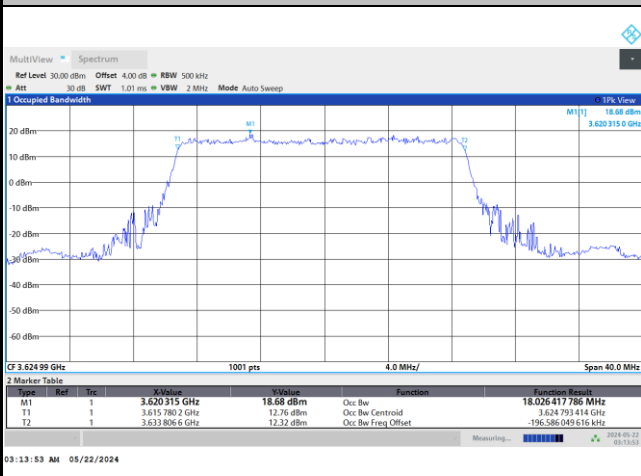

FR1 n48 / 20MHz / CP OFDM / Middle Channel / Full RB

QPSK

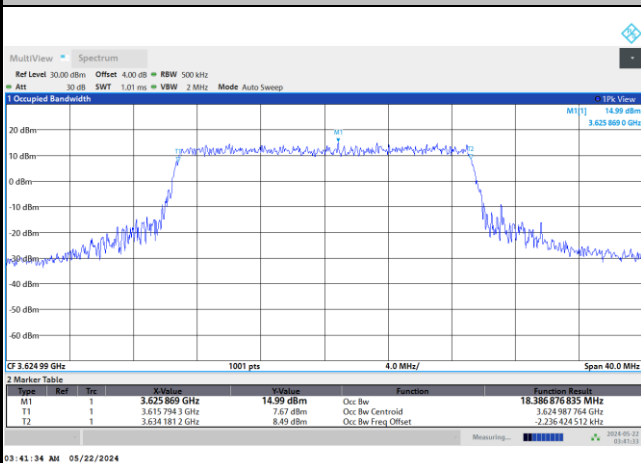

16QAM

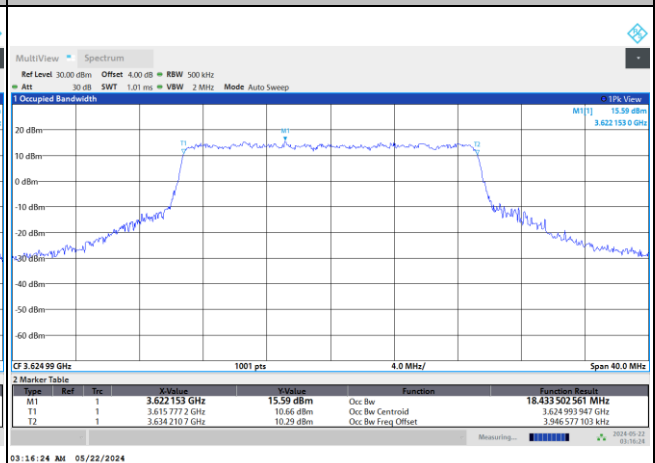

64QAM

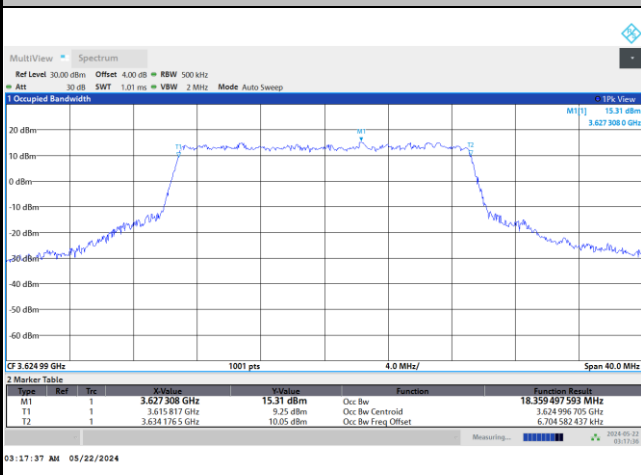

256QAM

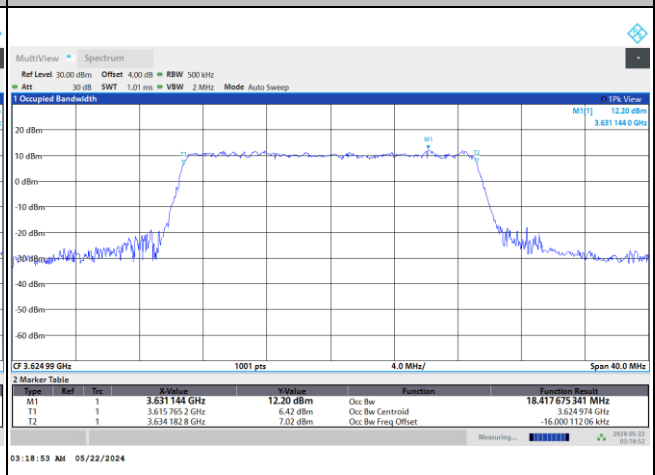



FR1 n48 / 30MHz / DFT-S OFDM / Middle Channel / Full RB

PI/2 BPSK

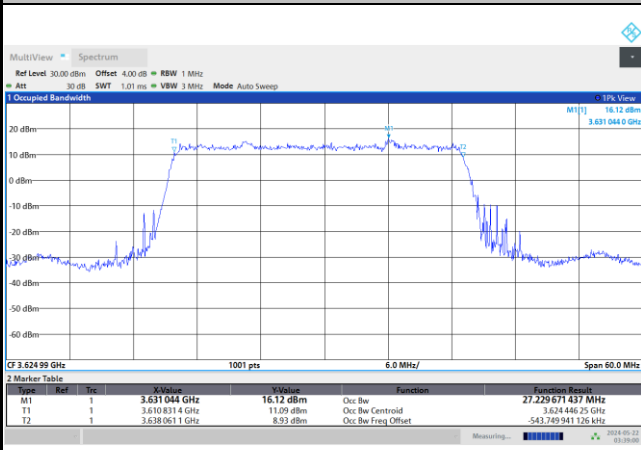

FR1 n48 / 30MHz / CP OFDM / Middle Channel / Full RB

QPSK

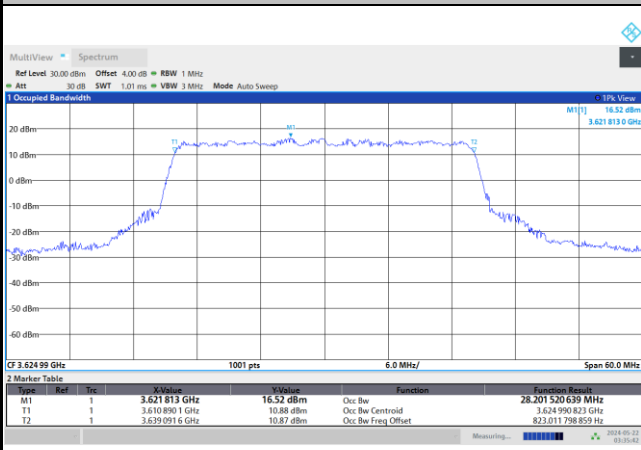

16QAM

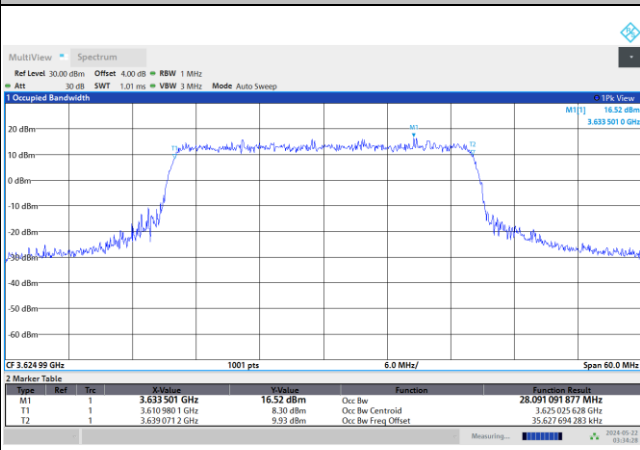

64QAM

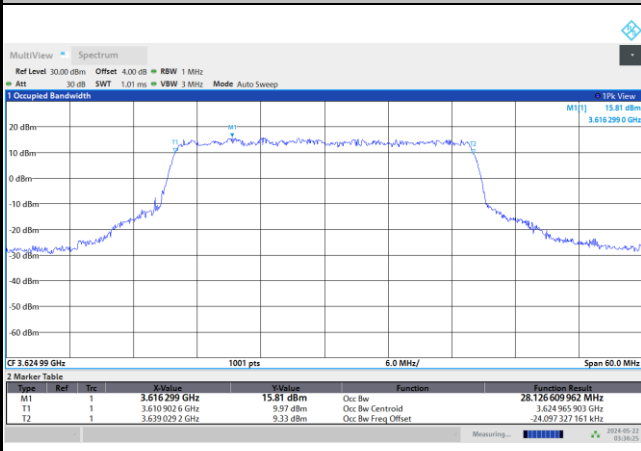

256QAM

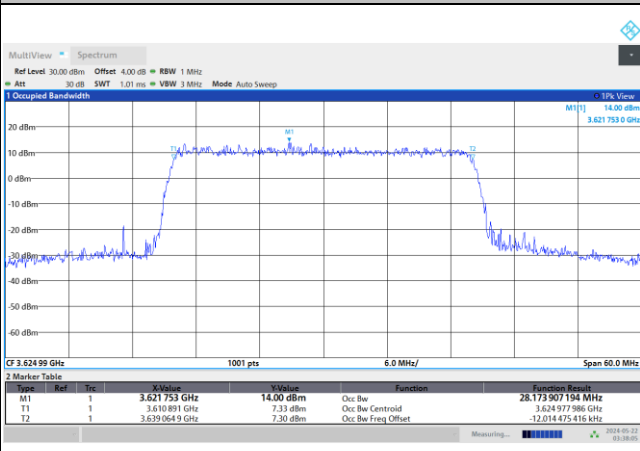



FR1 n48 / 40MHz / DFT-S OFDM / Middle Channel / Full RB

PI/2 BPSK

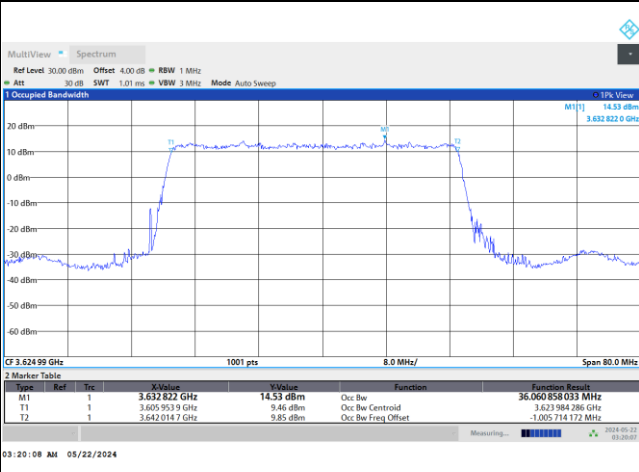

FR1 n48 / 40MHz / CP OFDM / Middle Channel / Full RB

QPSK

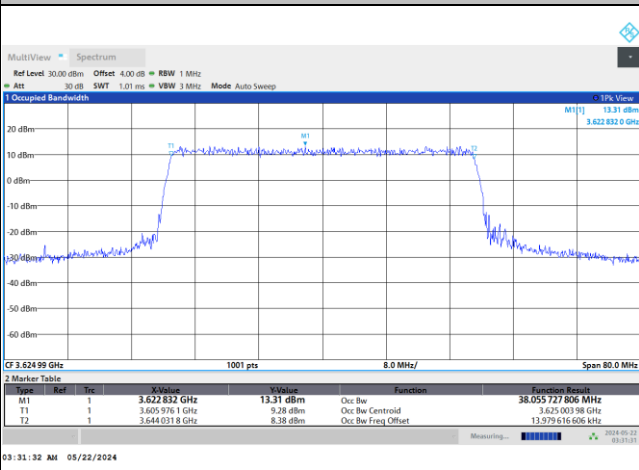

16QAM

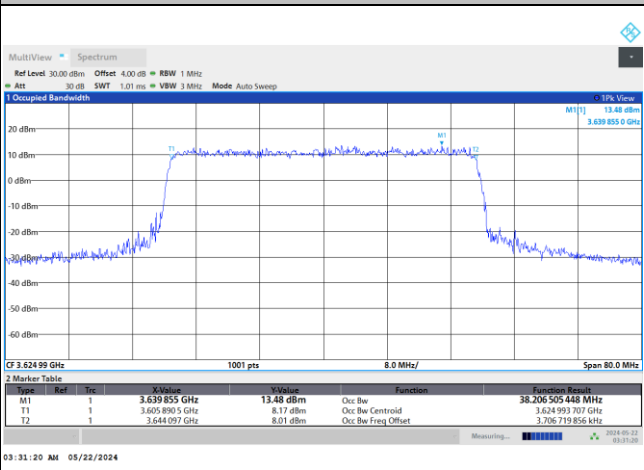

64QAM

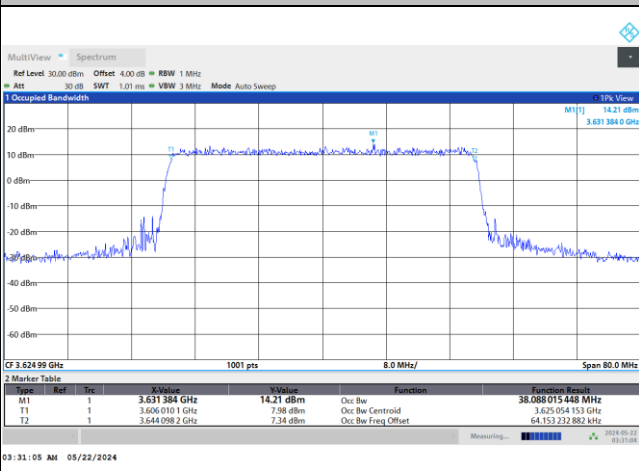

256QAM

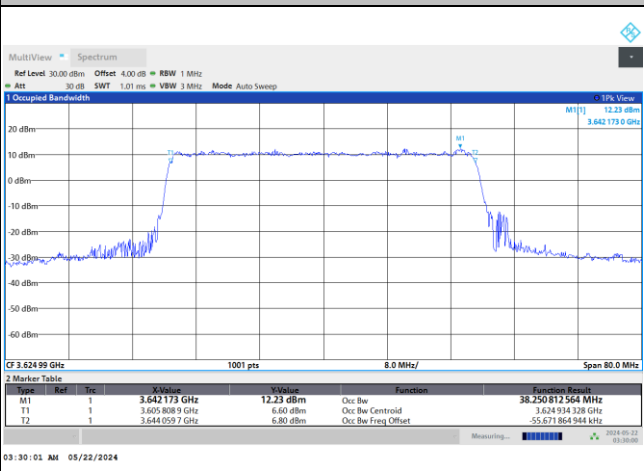



Unwanted Emission (MASK)

FR1 n48 / 10MHz / DFT-S OFDM / PI/2 BPSK

Lowest Channel

1RB0

1RBmax

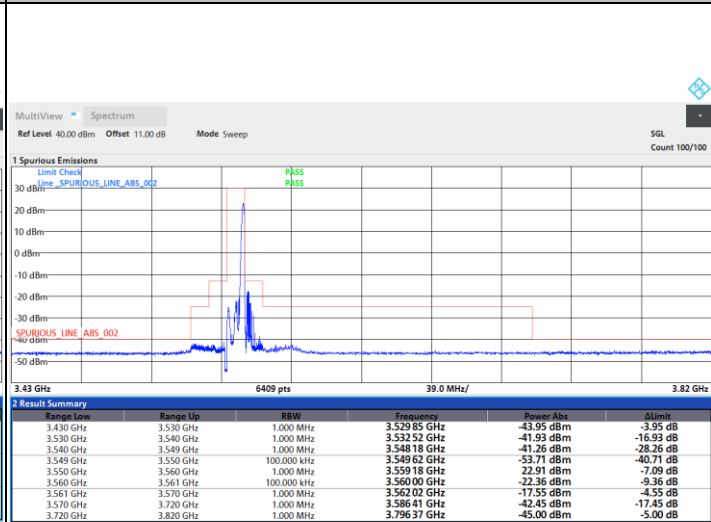
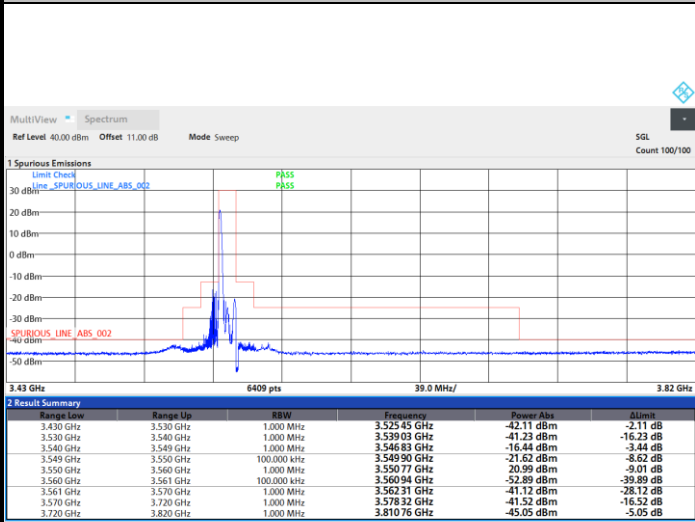

01:15:34 AM 05/22/2024

01:16:12 AM 05/22/2024

Full RB

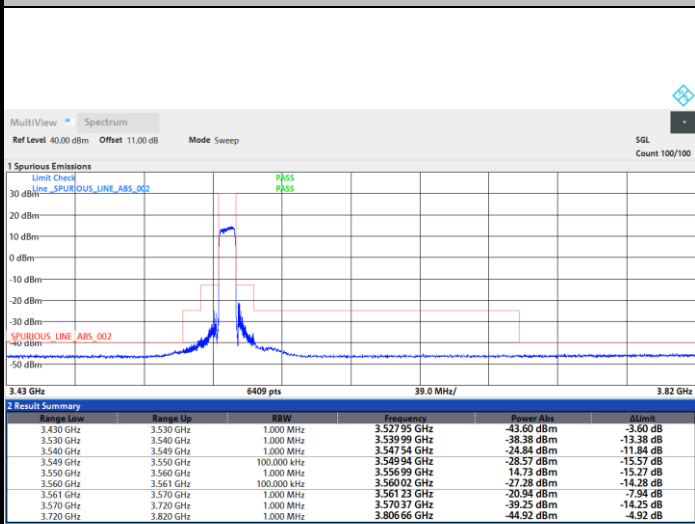

01:16:50 AM 05/22/2024



FR1 n48 / 10MHz / DFT-S OFDM / PI/2 BPSK

Middle Channel

1RB0

1RBmax

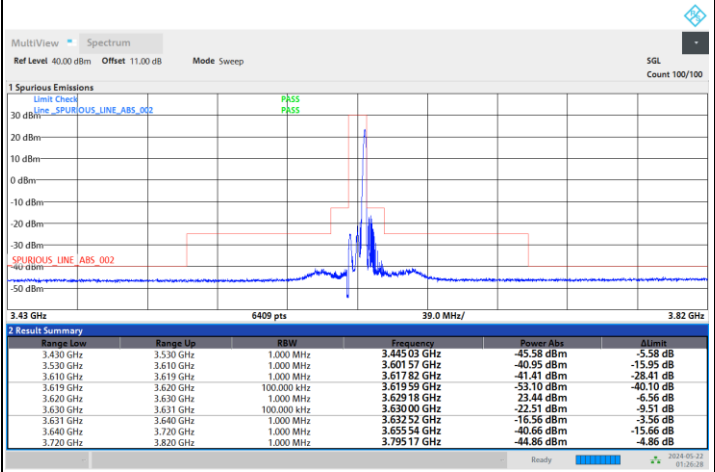
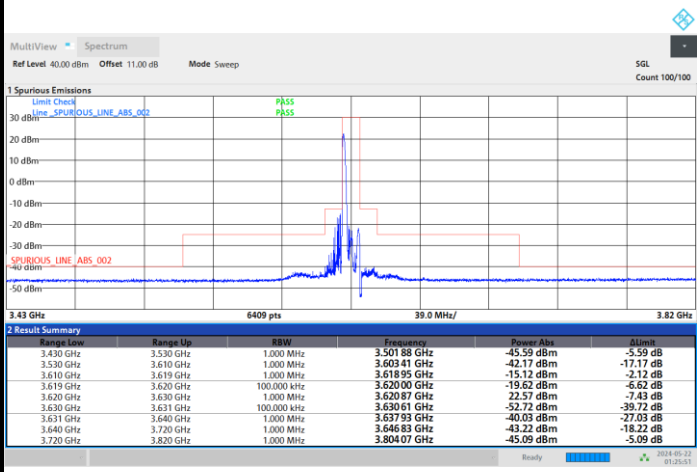

Full RB

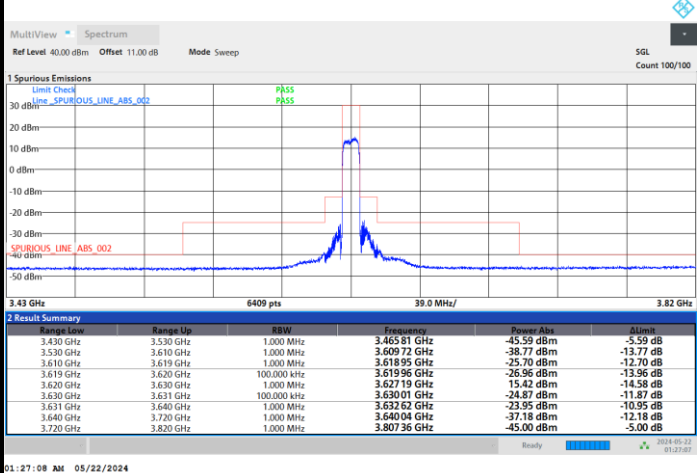



FR1 n48 / 10MHz / DFT-S OFDM / PI/2 BPSK

Highest Channel

1RB0

1RBmax

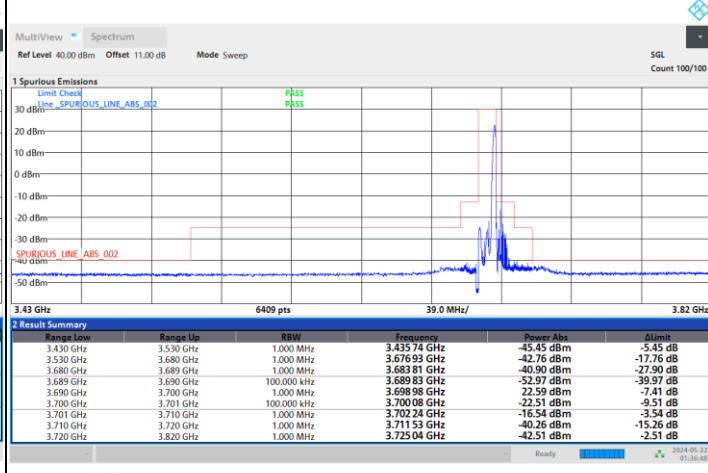
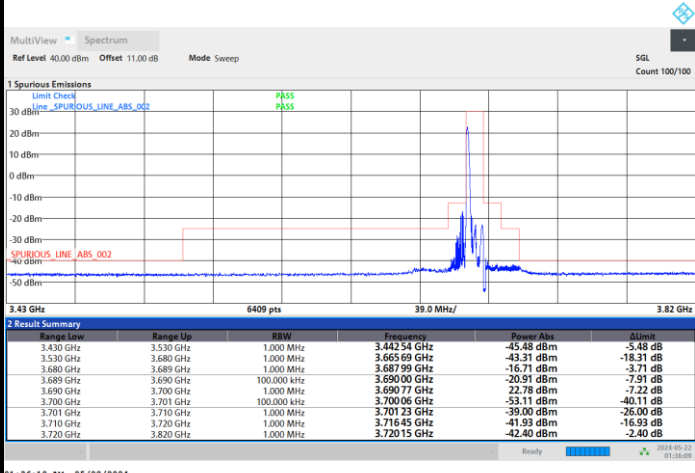

Full RB

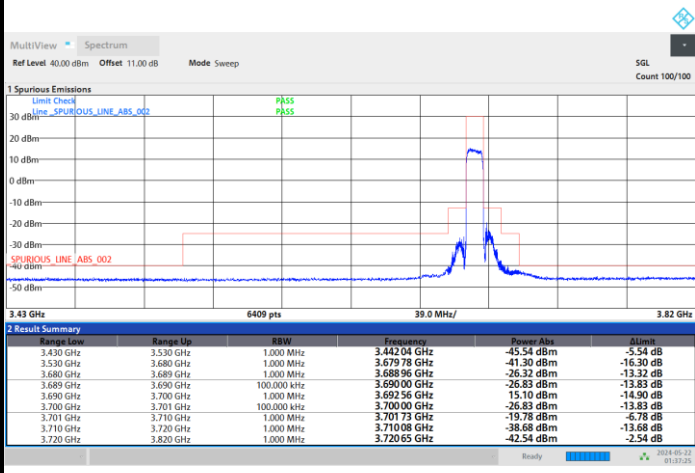



FR1 n48 / 10MHz / DFT-S OFDM / QPSK

Lowest Channel

1RB0

1RBmax

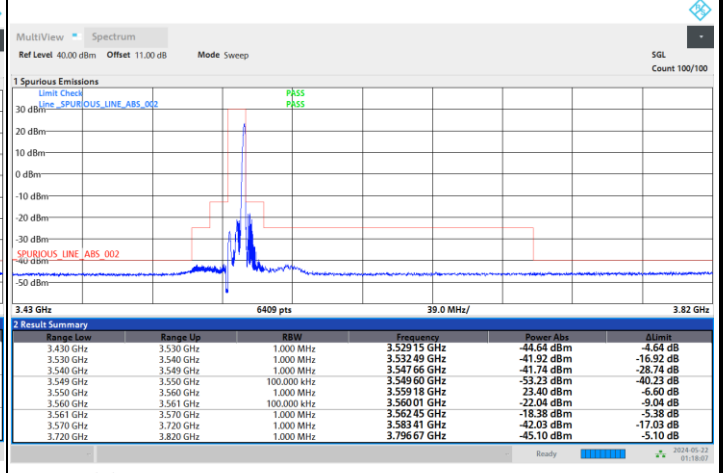
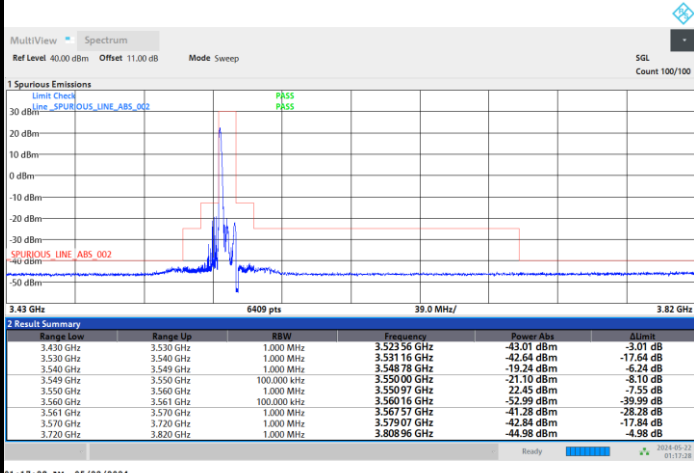

Full RB

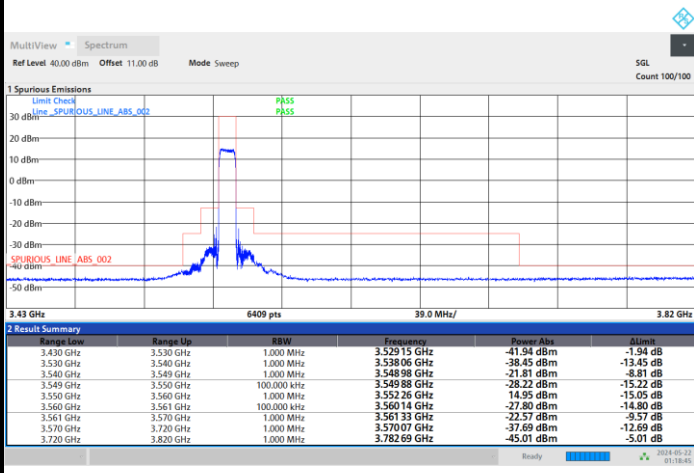



FR1 n48 / 10MHz / DFT-S OFDM / QPSK

Middle Channel

1RB0

1RBmax

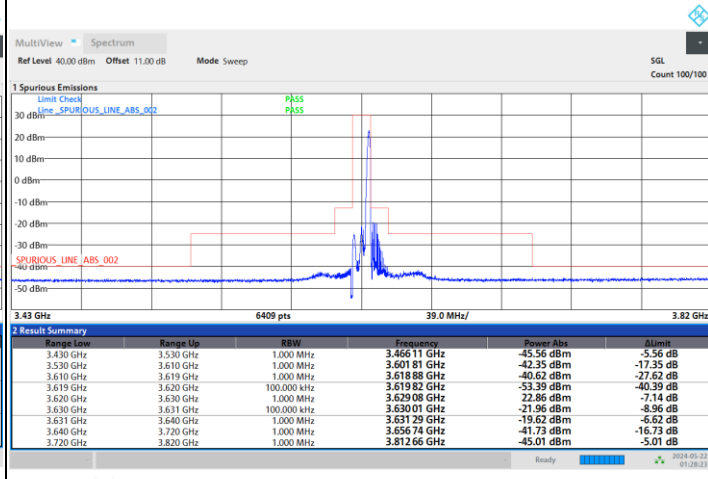
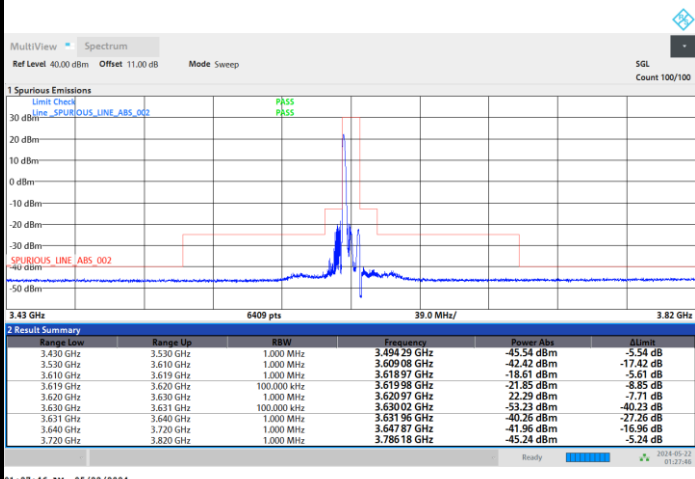

Full RB

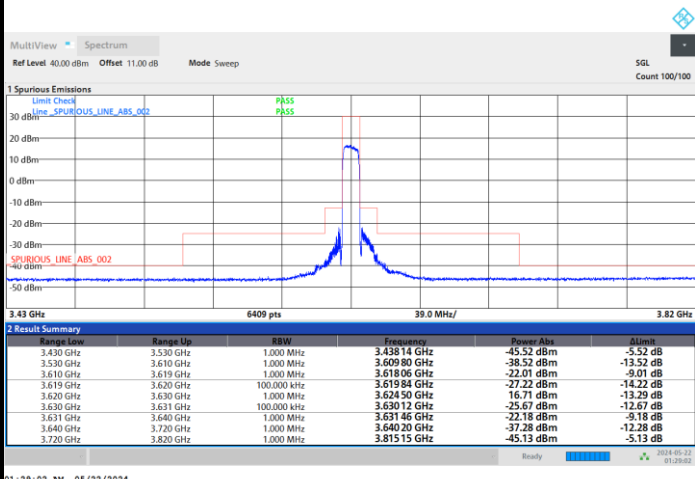



FR1 n48 / 10MHz / DFT-S OFDM / QPSK

Highest Channel

1RB0

1RBmax

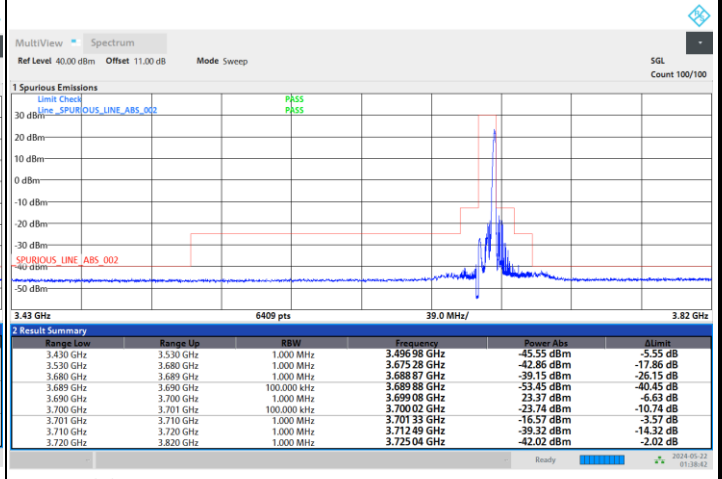
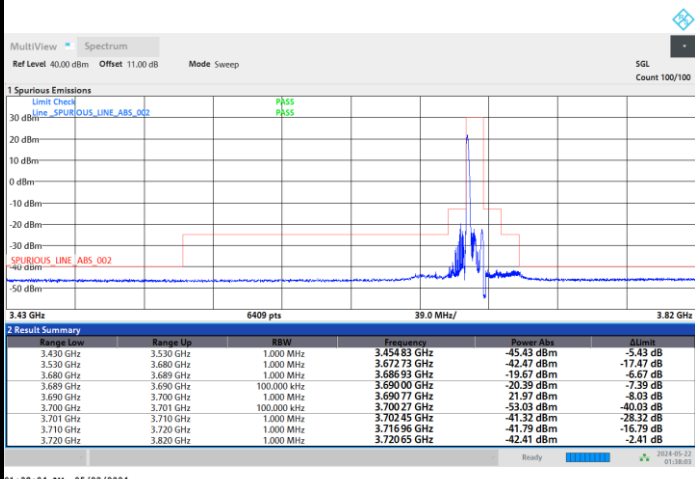

Full RB

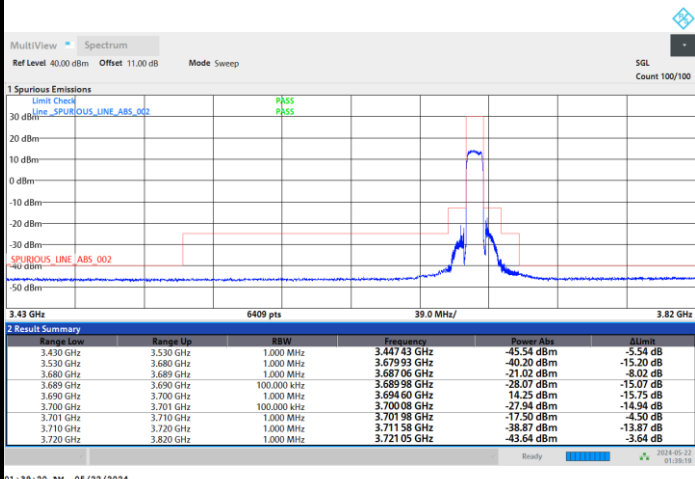



FR1 n48 / 10MHz / DFT-S OFDM / 16QAM

Lowest Channel

1RB0

1RBmax

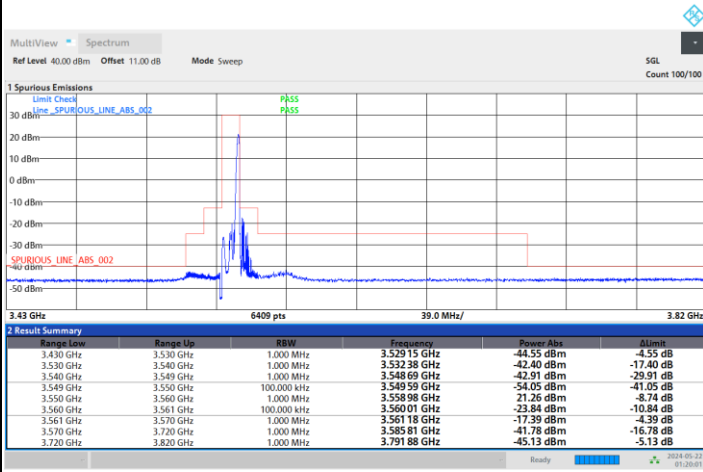
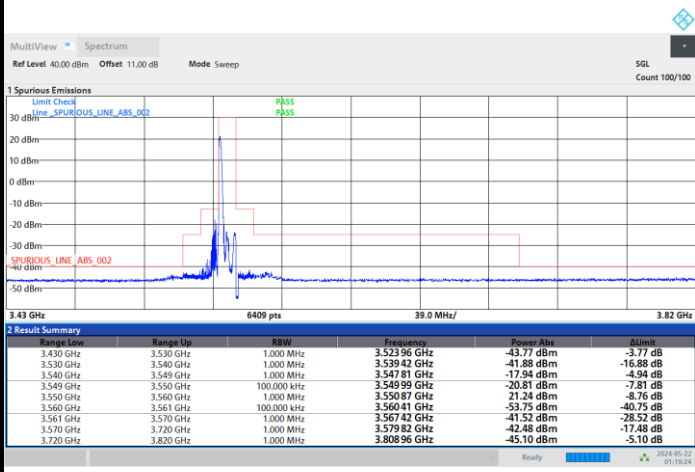

Full RB

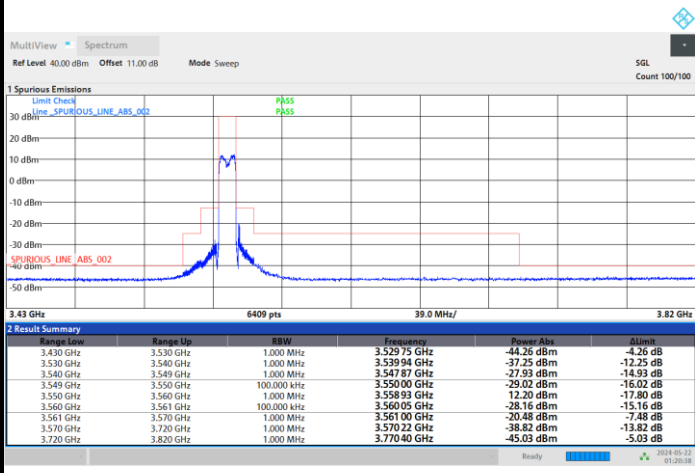



FR1 n48 / 10MHz / DFT-S OFDM / 16QAM

Middle Channel

1RB0

1RBmax

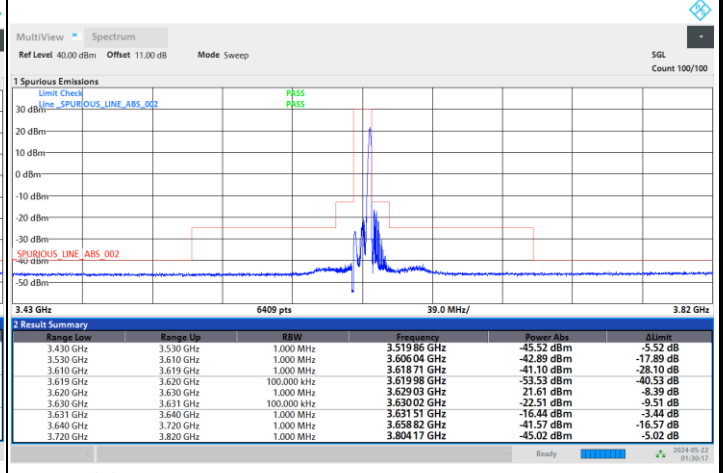
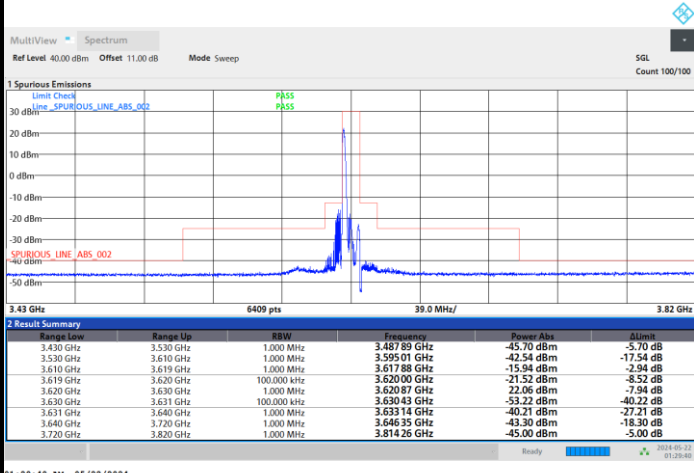

Full RB

