

SPECIFICATION

Antenna Manufacturer	Amphenol: Ant0, Ant1, Ant5, Ant6, Ant7 Haitong: Ant2+3, Ant4, Ant8, Ant9
Frequency Range	Ant 0: 617~960MHz Ant 1: 1710~2170, 2300~2690MHz Ant 2+3: 617~960, 1710~2170, 2300~2690MHz Ant 4: 2500~2690, 3300~4200MHz Ant 5: 2500~2690, 3300~4200MHz Ant 6: 3300~4200MHz Ant 7: 3300~4200MHz Ant 8: 1575, 2400~2500, 5150~7125MHz Ant 9: 2400~2500, 5150~7125MHz
Impedance	50 Ohms
Antenna type	Loop type: Ant0, Ant1, Ant6, Ant9 PIFA type: Ant4, Ant5 Monopole type: Ant7 Monopole+Coupling type: Ant2+3, Ant8
Process	LDS and FPC
TEST DATA	2024/03/06
DATASHEET REVISION	Rev 00

Antenna Gain

ANT0 (L/R)			ANT1 (MR/HR)			ANT2+3 (L/R-MR/HR)			ANT4 (HR-UHR)			ANT5 (HR-UHR)			ANT6 (UHR)			ANT7 (UHR)			ANT8 (W/FW/BT/CPS)			ANT9 (W/FH)		
Freq	Efficiency	Peak Gain	Freq	Efficiency	Peak Gain	Freq	Efficiency	Peak Gain	Freq	Efficiency	Peak Gain	Freq	Efficiency	Peak Gain	Freq	Efficiency	Peak Gain	Freq	Efficiency	Peak Gain	Freq	Efficiency	Peak Gain	Freq	Efficiency	Peak Gain
617	-7.33	-7.36	1710	-3.31	0.91	617	-11.23	-8.01	2300	-6.43	0.72	2300	-10.11	-4.54	3300	-4.52	0.04	3300	-5.54	-1.22	1559	4.52	0.56	2400	-3.99	0.30
635	-6.91	-6.66	1732	-2.96	1.31	635	-9.35	-6.68	2315	-6.34	1.08	2315	-9.38	-3.96	3400	-4.18	0.07	3400	-5.27	-1.10	1575	4.41	0.36	2410	-3.95	0.24
652	-6.54	-5.13	1755	-2.64	1.14	652	-9.49	-9.75	2316	-6.34	1.08	2316	-9.38	-3.96	3500	-4.08	-0.02	3500	-4.57	-0.13	1610	4.44	0.55	2420	-3.79	0.28
663	-6.75	-3.46	1785	-2.68	0.91	663	-8.97	-9.98	2350	-6.54	1.10	2350	-8.85	-1.98	3550	-4.20	-0.12	3550	-4.85	-0.43	2400	4.64	-1.40	2430	-3.74	0.25
680	-5.44	-2.96	1805	-2.66	1.73	680	-15.67	-10.77	2360	-6.96	0.67	2360	-9.14	-2.01	3600	-4.22	-0.24	3600	-4.86	-0.70	2410	4.51	-1.69	2440	-3.92	0.30
698	-5.28	-2.38	1850	-2.80	0.61	698	-12.19	-9.16	2400	-6.77	0.97	2400	-9.55	-2.56	3700	-4.57	-0.28	3700	-4.84	-0.96	2420	4.38	-1.42	2450	-3.89	0.30
699	-5.21	-2.02	1880	-2.56	0.29	699	-12.13	-9.54	2496	-6.58	1.22	2496	-8.78	-2.32	3750	-4.41	-0.52	3750	-4.73	-0.96	2430	4.35	-1.50	2460	-3.82	0.28
716	-5.31	-2.35	1910	-2.92	0.42	716	-10.93	-7.70	2500	-6.57	1.23	2500	-7.20	-2.32	3800	-4.49	-0.50	3800	-4.72	-0.60	2440	4.37	-1.53	2470	-3.97	0.26
725	-5.31	-2.70	1915	-3.00	0.22	725	-9.64	-6.43	2570	-6.13	1.37	2570	-6.58	-0.34	4200	-4.45	0.00	4200	-3.42	-0.30	2450	4.41	-1.10	2480	-3.95	0.27
748	-5.16	-2.48	1930	-3.44	0.10	748	-8.69	-6.41	2593	-5.61	1.71	2593	-5.99	0.21							2460	4.40	-1.84	2490	-3.86	0.18
777	-5.29	-1.92	1960	-3.76	0.06	777	-9.29	-6.73	2620	-5.39	1.93	2620	-5.46	0.77							2470	4.40	-1.97	2500	-3.82	0.20
787	-5.72	-2.31	1990	-3.53	-1.64	787	-9.45	-6.89	2655	-4.96	1.96	2655	-4.96	1.23							2480	4.43	-1.93	5150	-3.78	0.50
791	-6.18	-3.33	1995	-3.93	0.02	791	-10.26	-7.10	2690	-5.04	1.84	2690	-4.80	1.69							2490	4.39	-1.50	5200	-3.77	0.19
814	-5.55	-2.63	2110	-5.09	-0.94	814	-10.66	-7.66	3300	-6.41	-0.45	3300	-4.79	0.17							2500	4.33	-1.30	5250	-3.86	0.10
823	-5.12	-2.49	2132	-5.54	-1.07	823	-11.34	-8.00	3400	-6.94	-0.96	3400	-5.60	-0.70							5150	3.96	0.30	5300	-3.67	0.08
824	-5.02	-2.60	2155	-5.55	-1.06	824	-10.73	-8.27	3500	-6.49	-1.68	3500	-5.56	-0.30							5200	3.88	0.54	5350	-3.62	0.60
836	-5.20	-2.31	2170	-5.59	-1.05	836	-9.66	-7.11	3550	-6.46	-1.27	3550	-5.60	-0.23							5250	3.66	0.90	5400	-4.02	-0.61
849	-5.16	-2.63	2200	-5.59	-0.88	849	-8.86	-6.12	3600	-6.52	-0.47	3600	-5.57	-0.85							5300	3.60	0.87	5450	-3.91	0.60
850	-5.36	-2.03	2300	-4.20	-0.57	850	-8.62	-5.82	3700	-5.90	-0.43	3700	-5.69	-0.64							5350	3.66	0.80	5500	-3.90	0.46
862	-5.76	-2.55	2315	-4.32	-0.50	862	-8.31	-5.42	3750	-5.89	-0.19	3750	-5.94	-0.91							5400	3.35	1.05	5550	-3.92	0.20
880	-5.68	-1.43	2316	-4.32	-0.50	880	-8.47	-5.63	3800	-5.15	0.14	3800	-6.40	-1.43							5450	3.40	1.00	5600	-3.90	0.59
898	-5.34	-2.18	2350	-4.50	-0.97	898	-9.16	-6.43	4200	-6.98	0.34	4200	-6.82	-2.57							5500	3.25	1.08	5650	-4.03	0.80
915	-5.68	-1.36	2360	-4.96	-1.35	915	-8.70	-5.83													5550	3.01	1.20	5700	-4.06	0.78
925	-5.53	-2.47	2400	-4.67	-1.12	925	-8.44	-5.48													5600	3.19	1.57	5750	-4.03	1.10
942	-5.48	-2.66	2496	-5.97	-2.91	942	-8.17	-5.22													5650	3.25	1.70	5800	-3.85	1.10
960	-5.89	-3.46	2500	-5.98	-3.00	960	-9.24	-4.28													5700	3.27	1.67	5850	-3.64	0.20
			2570	-6.09	-2.31	1805	-4.21	-0.09													5750	2.94	2.10	5925	-3.40	0.49
			2593	-5.99	-1.63	1843	-4.85	-0.53													5800	3.05	2.03	5950	-3.43	0.85
			2620	-6.08	-1.60	1850	-5.06	-0.71													5850	2.93	2.00	6025	-3.52	1.20
			2655	-5.88	-2.06	1880	-5.05	-0.67													5925	3.08	1.30	6125	-3.51	0.45
			2690	-5.79	-2.96	1910	-4.83	-0.22													5950	3.13	1.49	6225	-3.57	1.20
						1920	-4.63	0.12													6025	2.95	1.60	6325	-3.39	1.20
						1930	-4.60	0.16													6125	2.70	1.16	6425	-3.44	0.60
						1950	-4.65	0.26													6225	3.28	0.90	6525	-3.57	0.44
						1960	-4.71	0.21													6325	3.23	1.31	6625	-3.97	0.60
						1980	-4.93	0.22													6425	3.63	1.20	6725	-4.04	0.13
						1990	-5.18	0.86													6525	3.36	0.34	6825	-3.82	0.20
						2110	-5.32	-1.50													6625	3.65	0.40	6925	-4.00	0.23
						2133	-5.31	-1.10													6725	3.51	0.38	7025	-3.97	0.30
						2140	-5.37	-1.09													6825	3.89	0.40	7125	-3.79	0.08
						2155	-5.26	-0.86													6925	3.84	1.13			
						2170	-5.20	-0.74													7025	3.84	1.30			
						2200	-5.01	-0.44													7125	3.97	0.56			
						2300	-4.44	0.45																		
						2350	-4.25	0.77																		
						2400	-4.31	0.21																		
						2500	-6.16	-4.97																		
						2535	-7.16	-7.10																		
						2570	-6.30	-7.54																		
						2620	-5.84	-6.85																		
						2655	-5.64	-6.66																		
						2690	-5.70	-6.98																		

2D Radiation Pattern

Ant 0(LB)_700MHz

XY

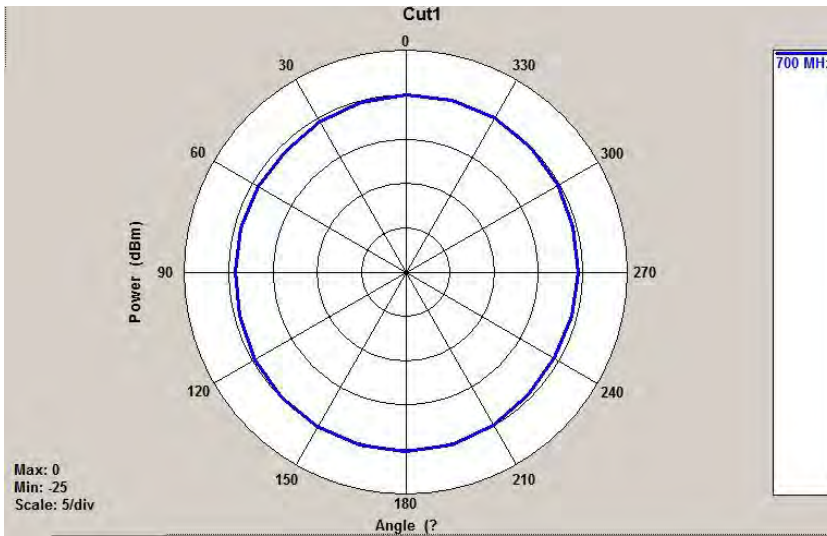

XZ

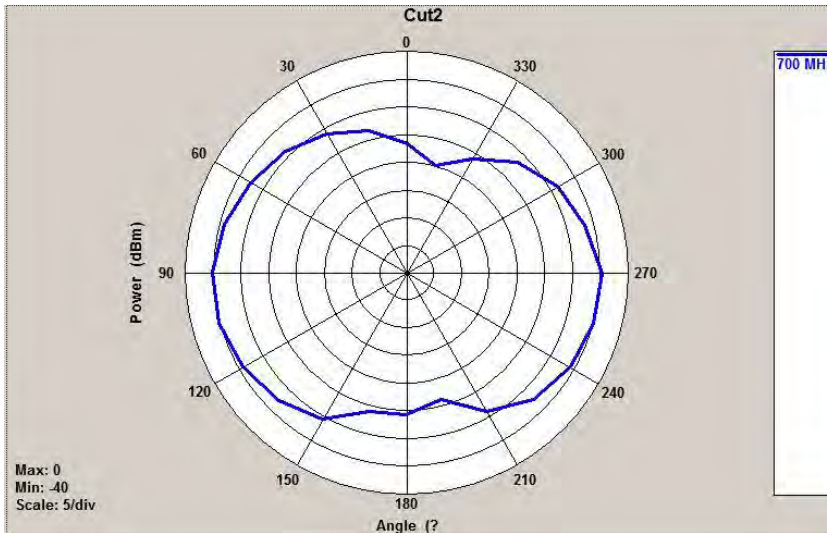

YZ

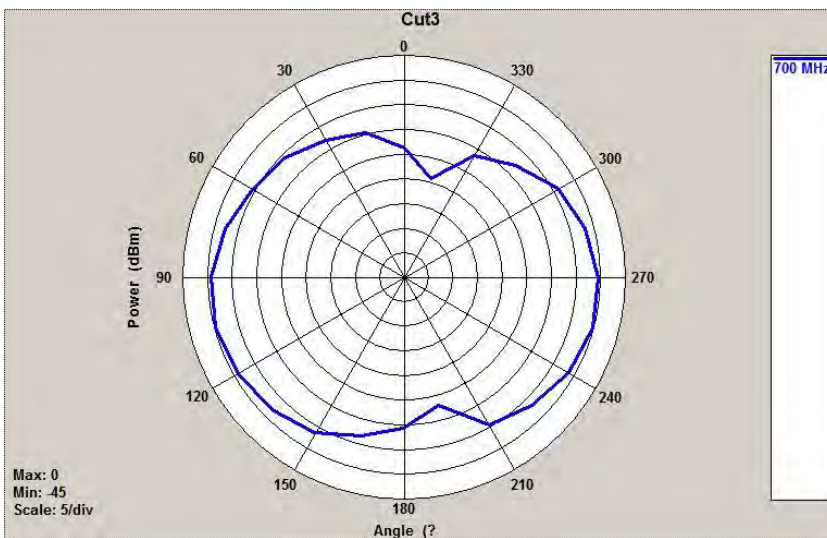

Ant 0(LB)_800MHz

XY

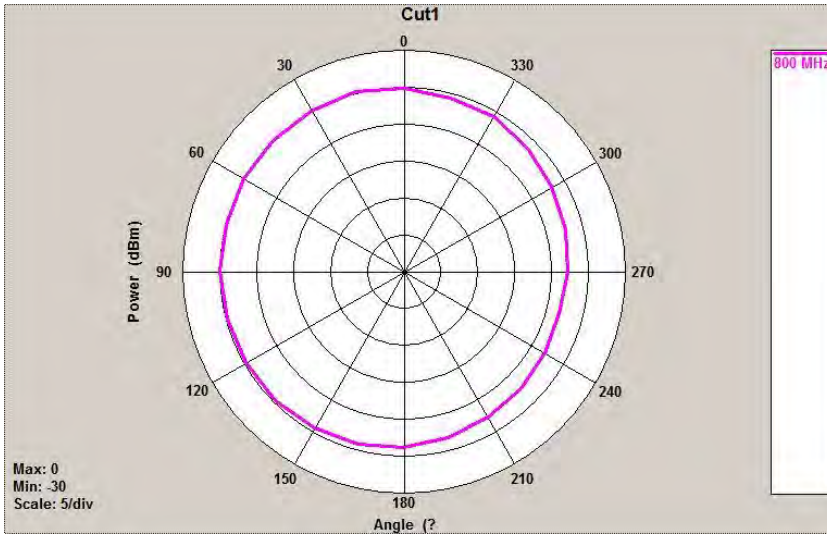

XZ

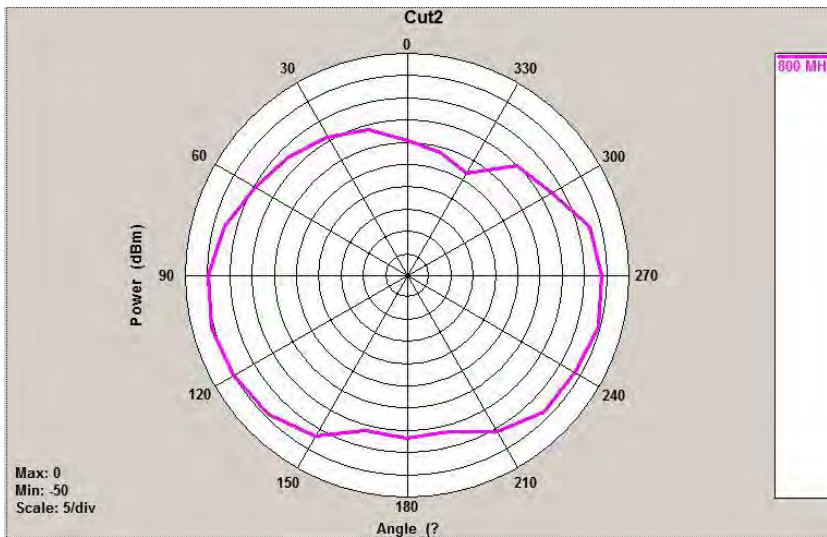

YZ

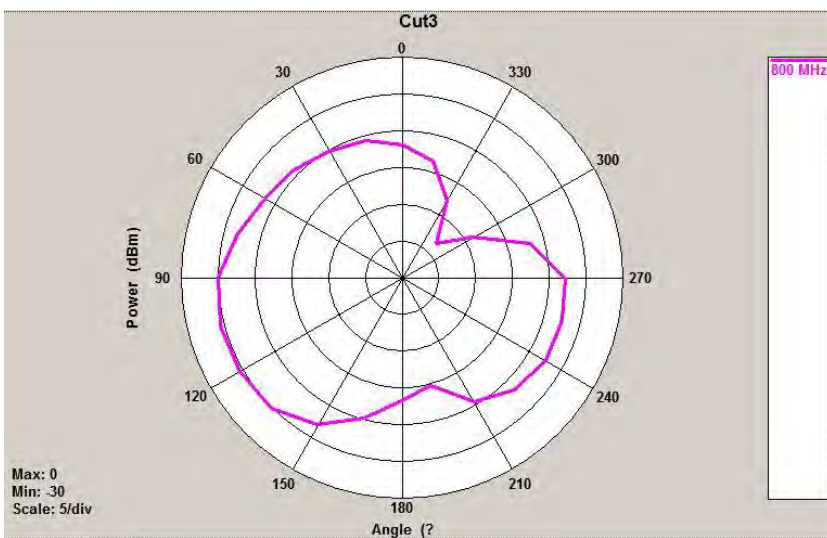

Ant 0(LB)_900MHz

XY

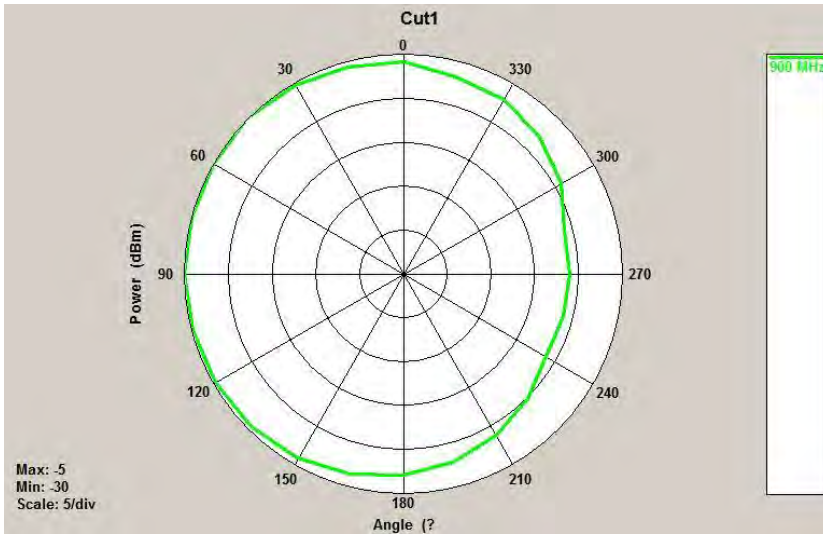

XZ

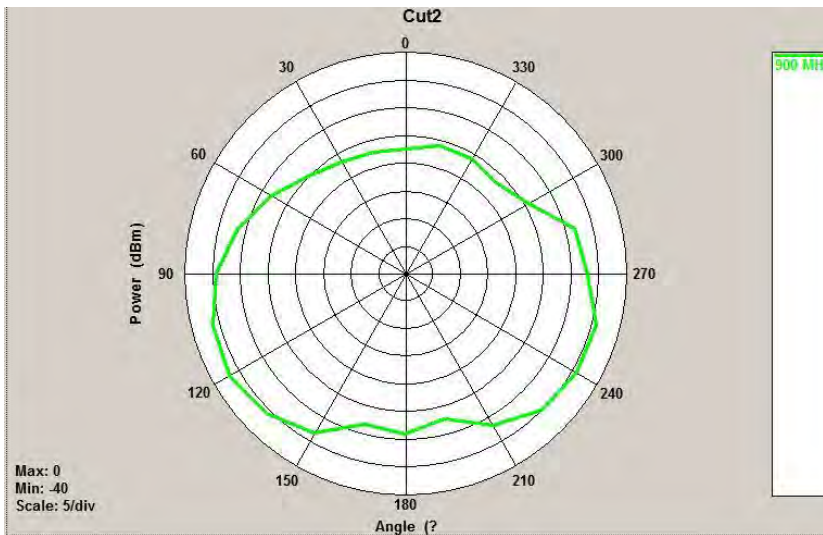

YZ

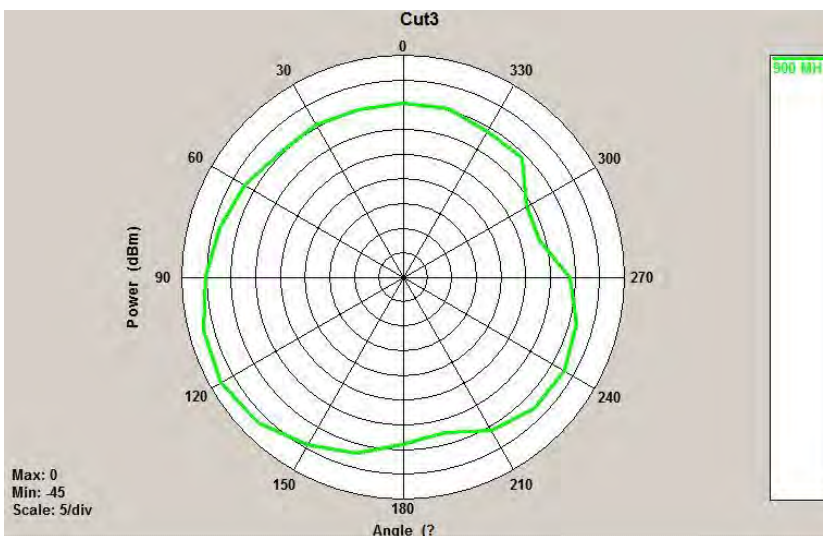

Ant 1(MB+HB)_1710MHz_2170MHz_2300MHz_2600MHz XY

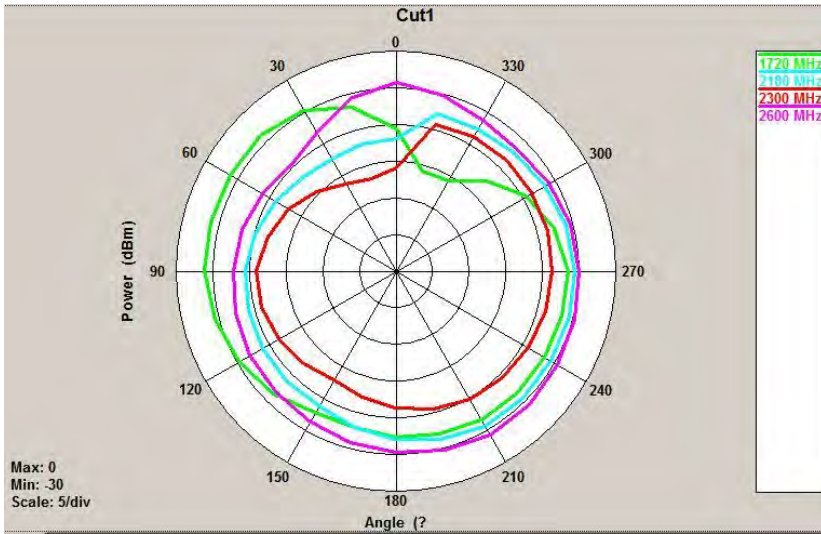

XZ

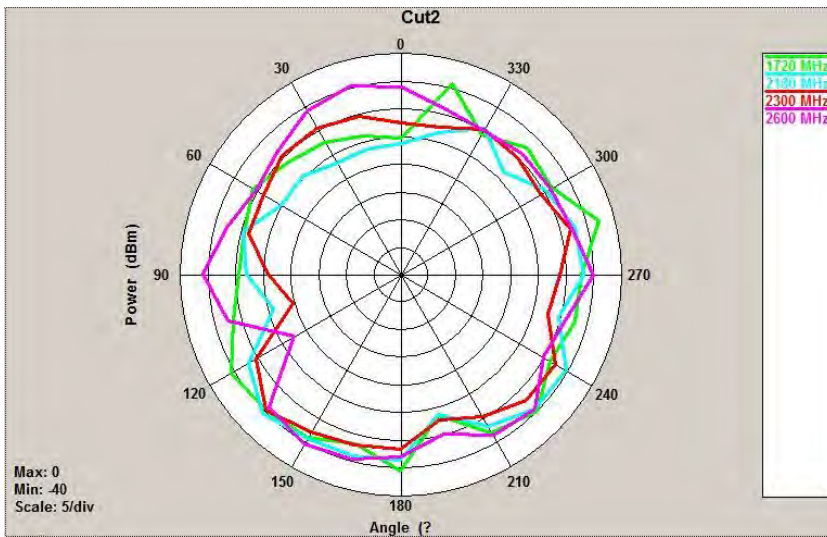

YZ

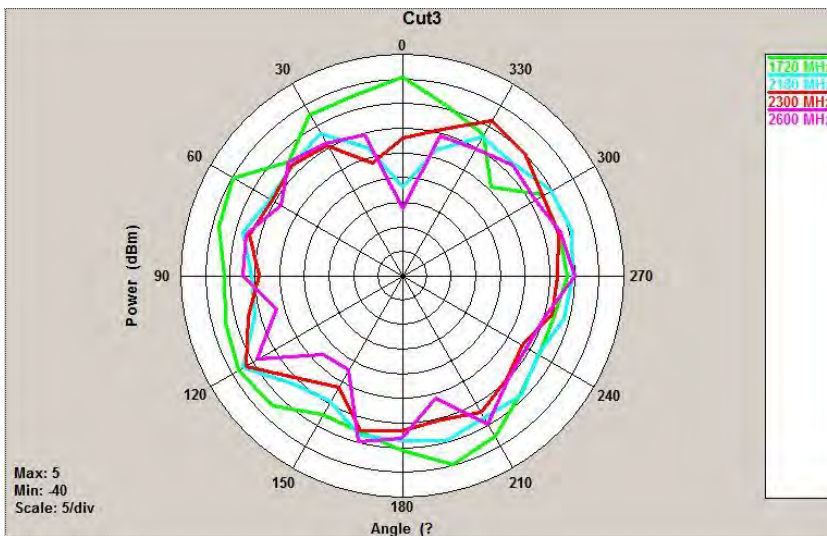

Ant 2+3(LB+MB+HB)_700MHz

XY

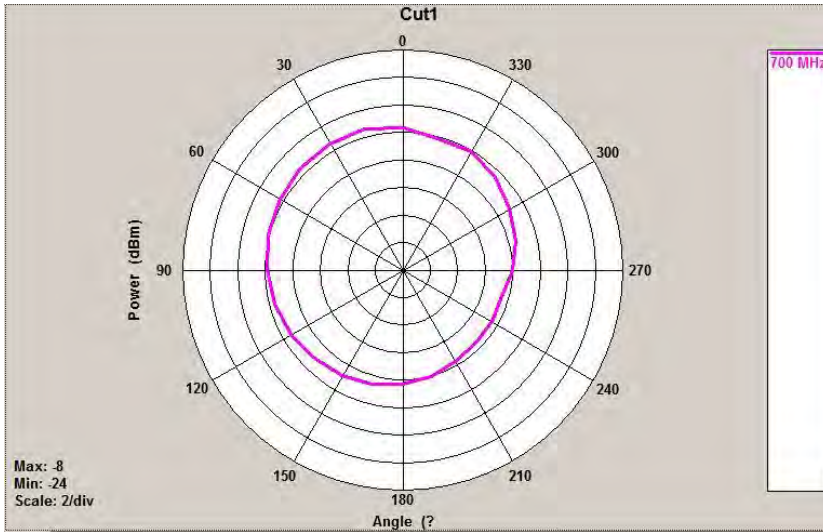

XZ

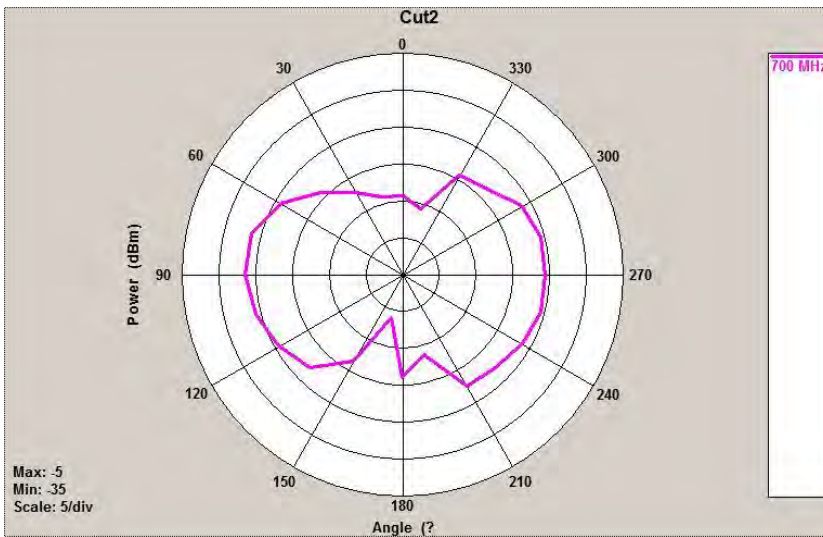

YZ

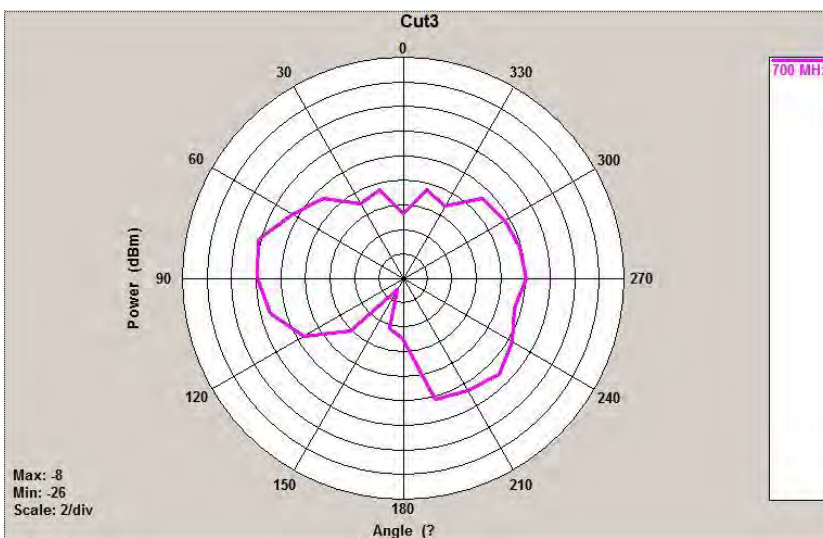

Ant 2+3(LB+MB+HB)_800MHz

XY

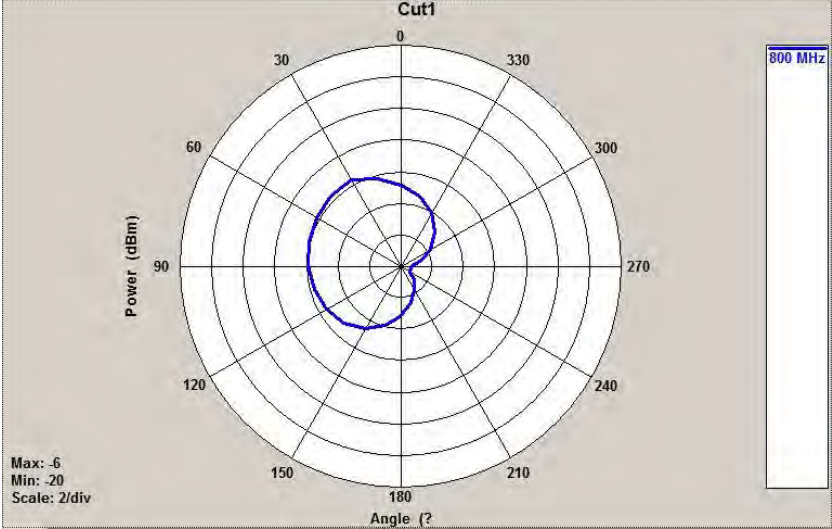

XZ

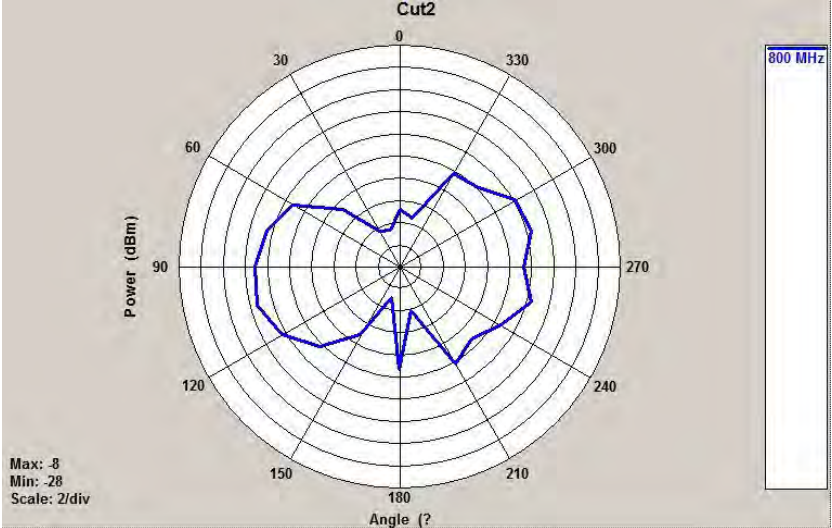

YZ

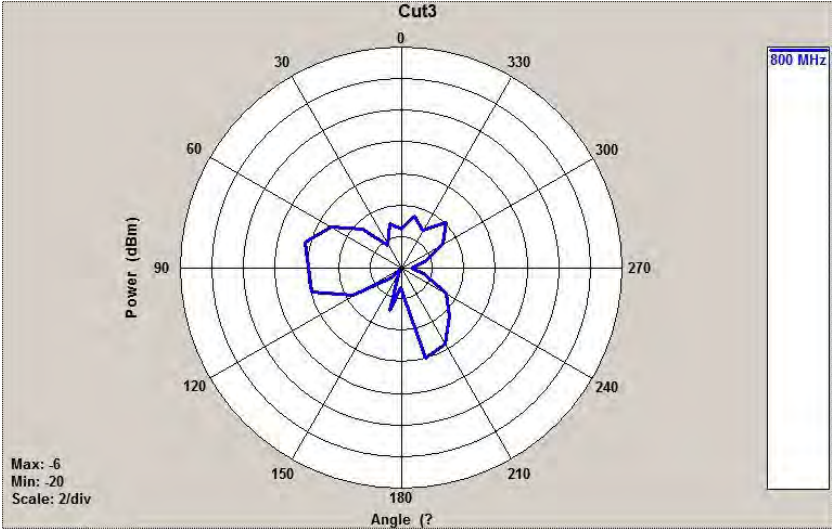

Ant 2+3(LB+MB+HB)_900MHz

XY

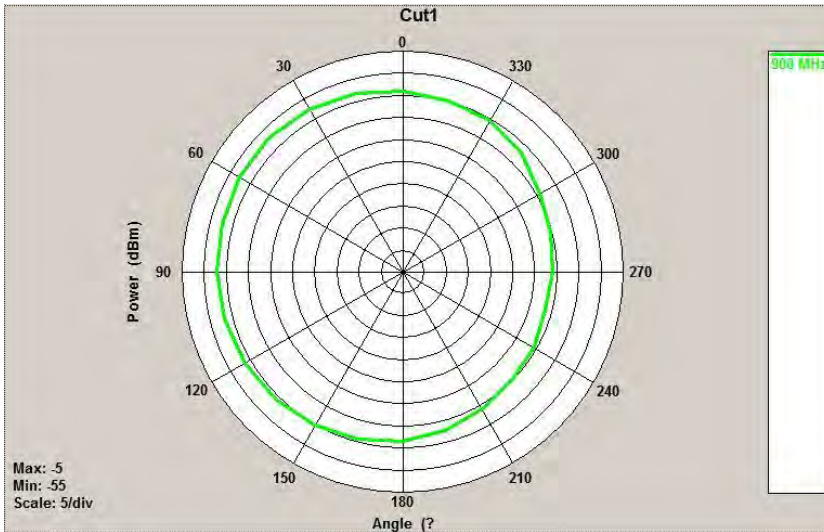

XZ

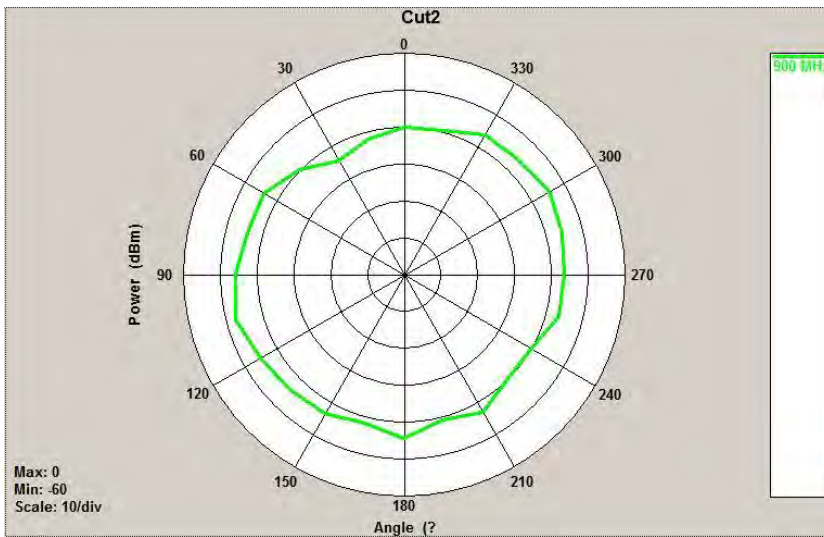

YZ

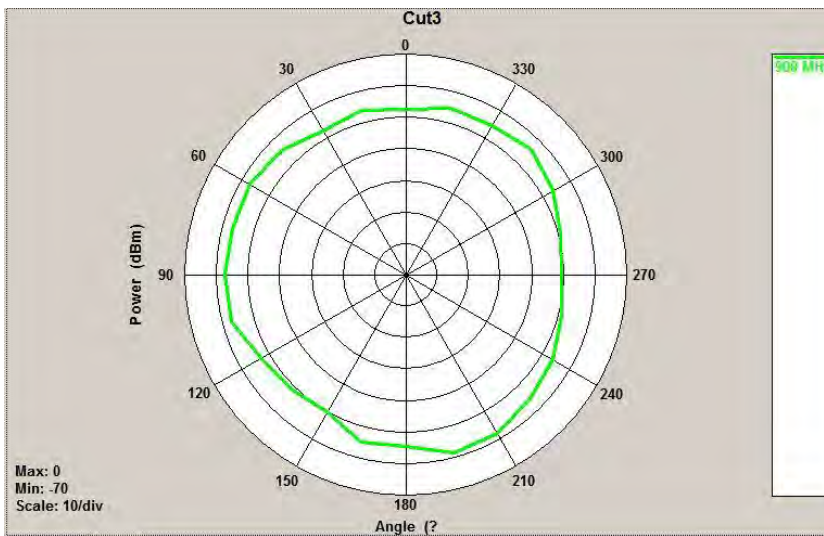

Ant 2+3(LB+MB+HB)_1710MHz_2170MHz_2300MHz_2600MHz XY

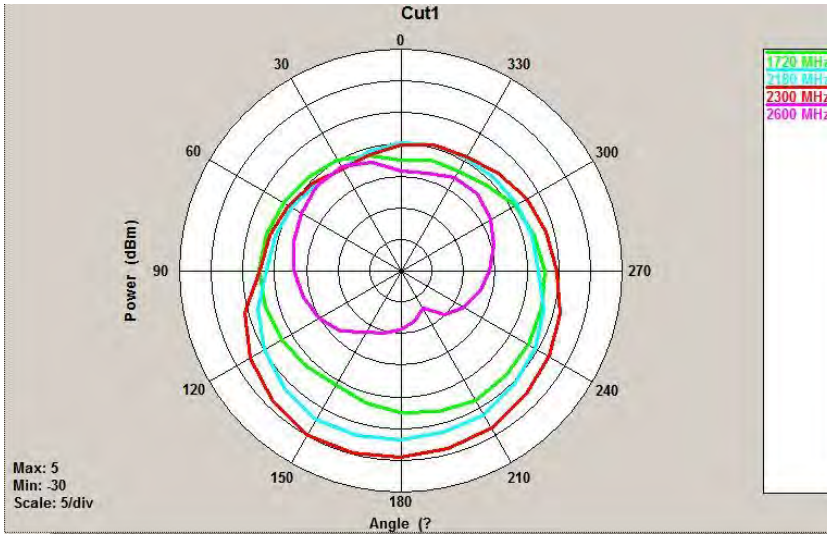

XZ

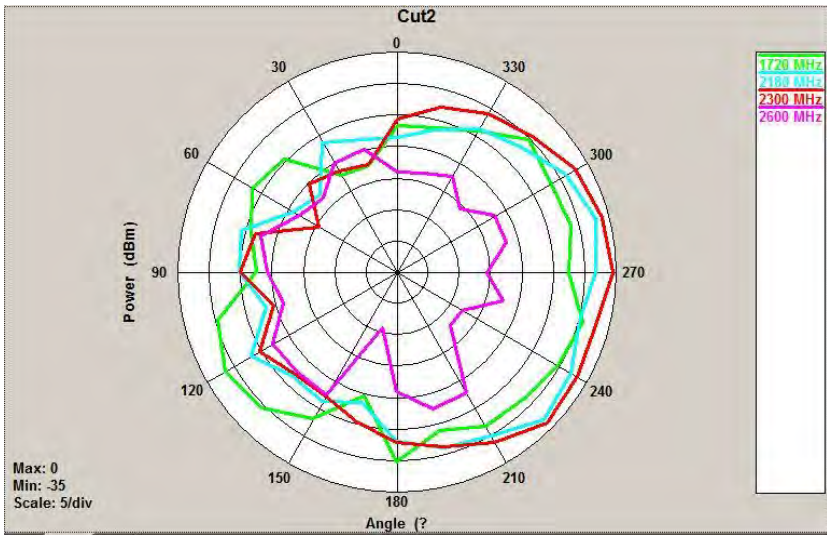

YZ

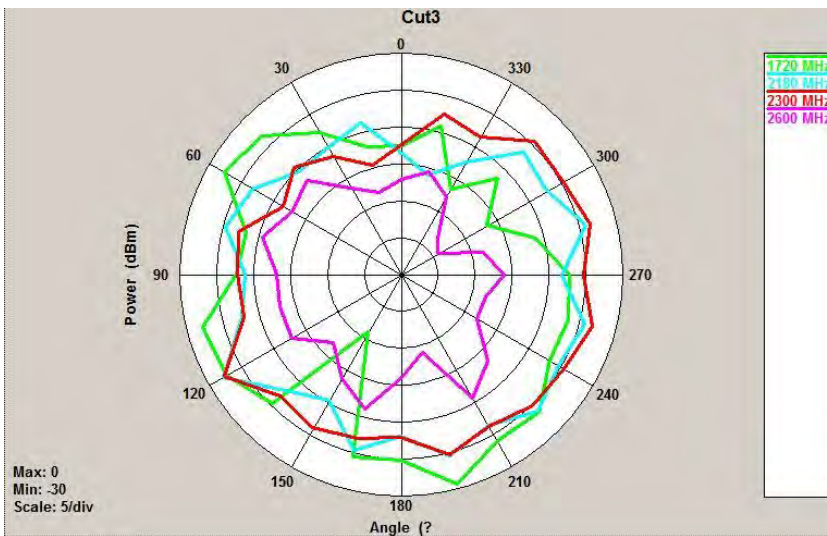

Ant 4(HB+UHB)_2600MHz

XY

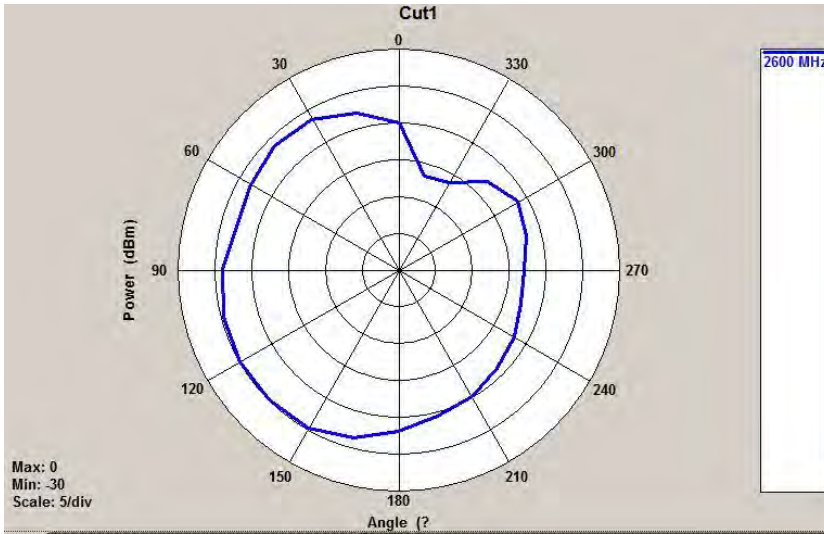

XZ

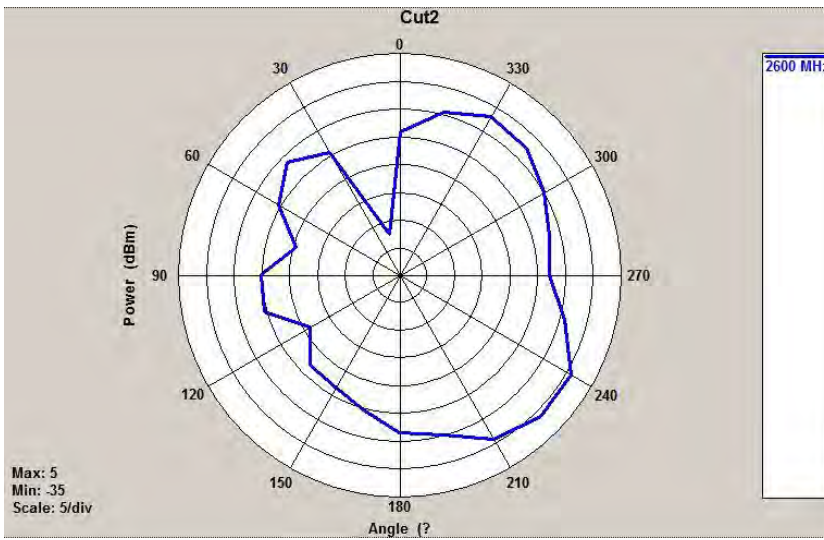

YZ

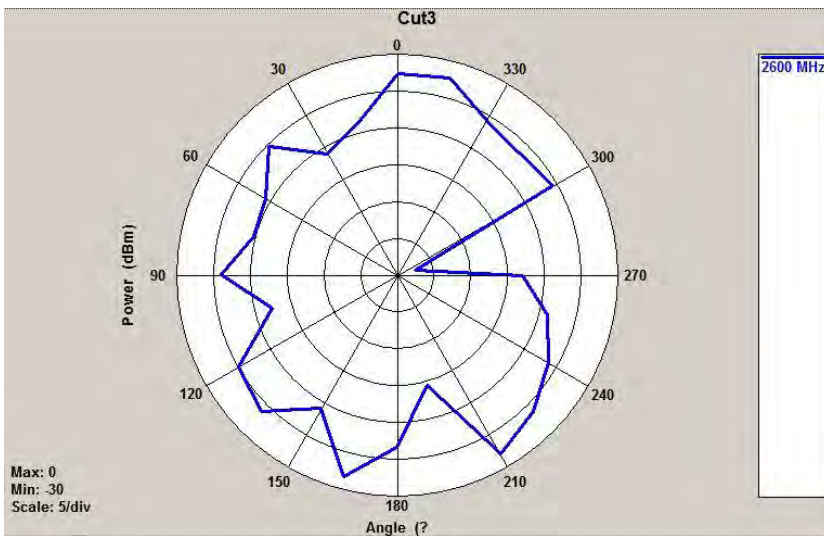

Ant 4(HB+UHB)_3500MHz

XY



XZ

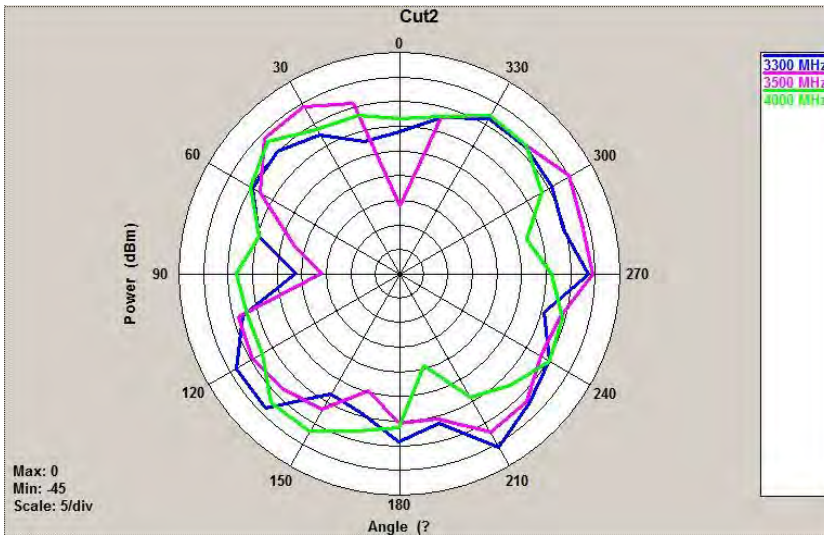

YZ

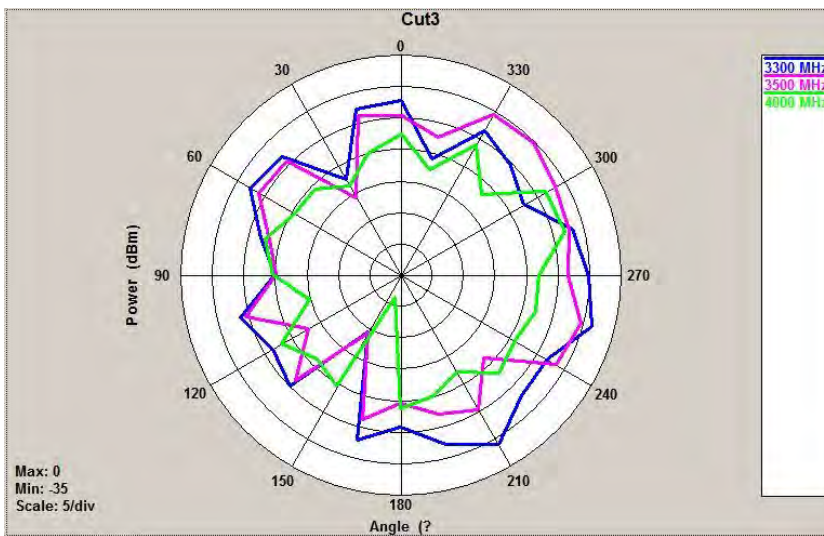

Ant 5(HB+UHB)_2600MHz

XY

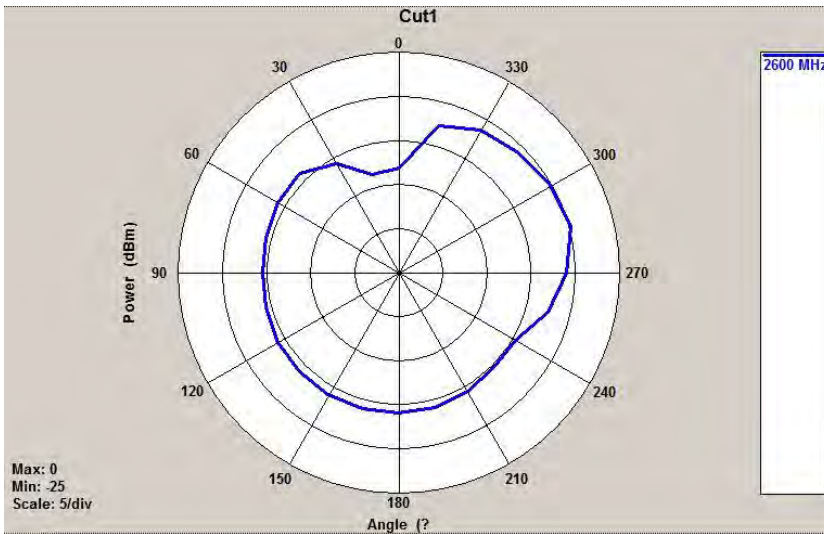

XZ

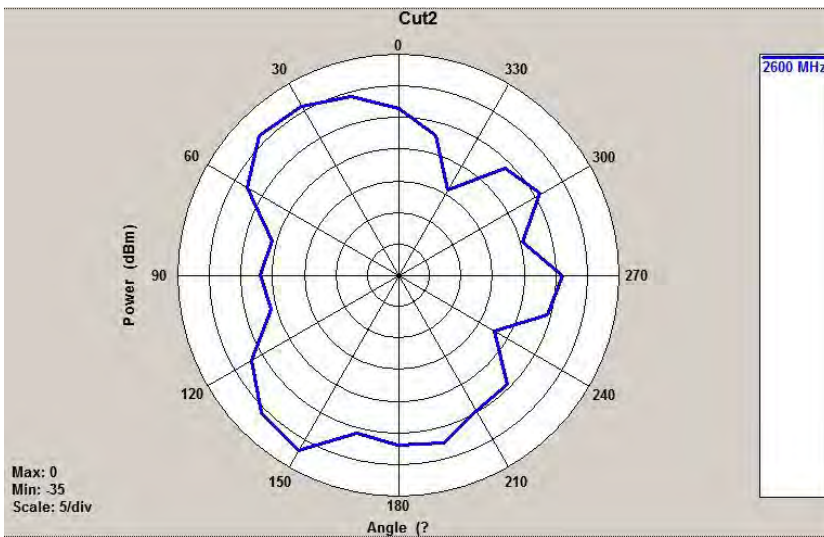

YZ

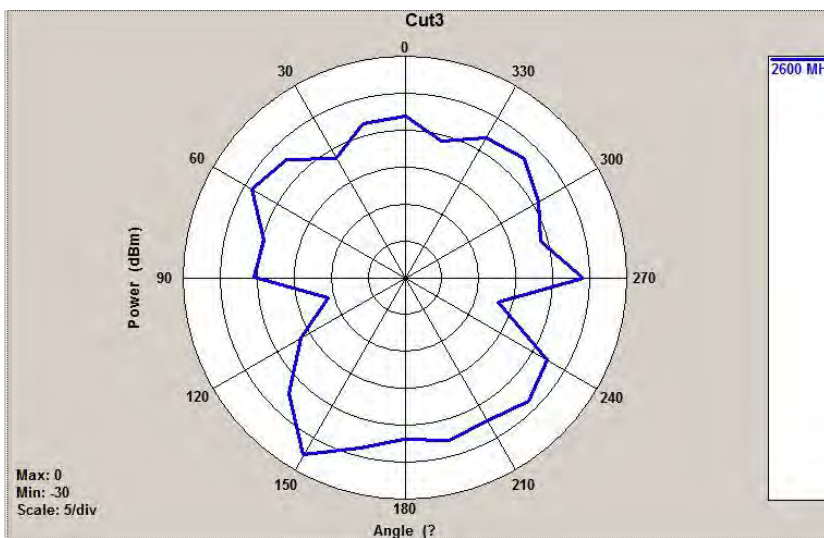

Ant 5(HB+UHB)_3500MHz

XY

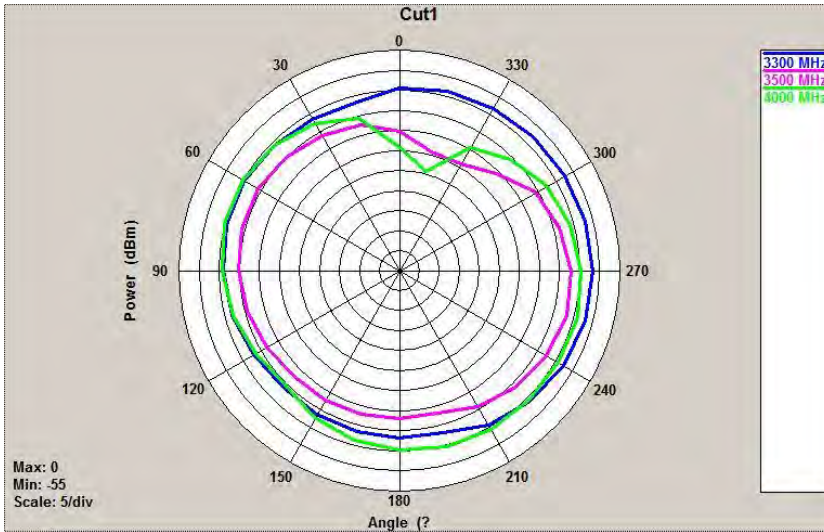

XZ

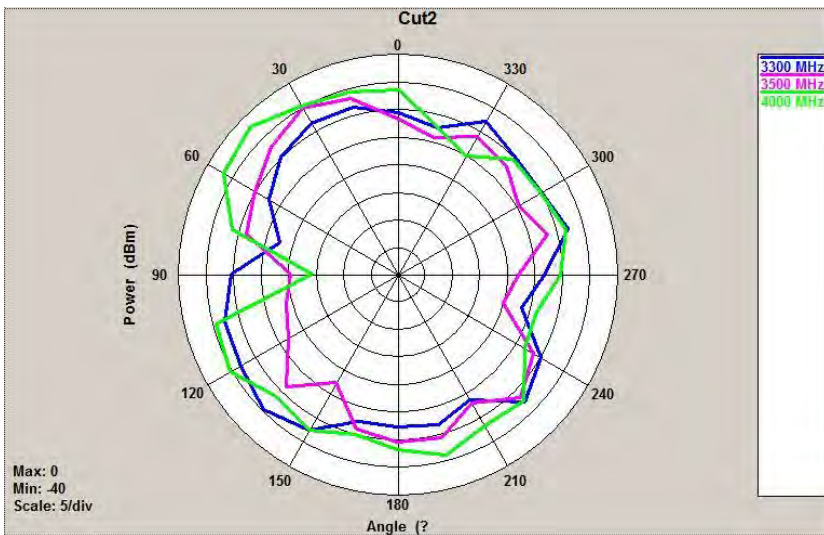

YZ

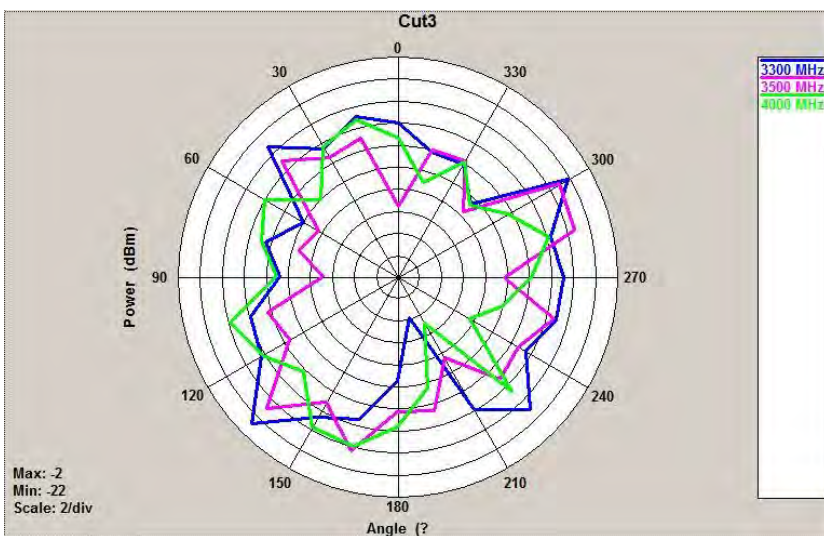

Ant 6(UHB)_3500MHz

XY

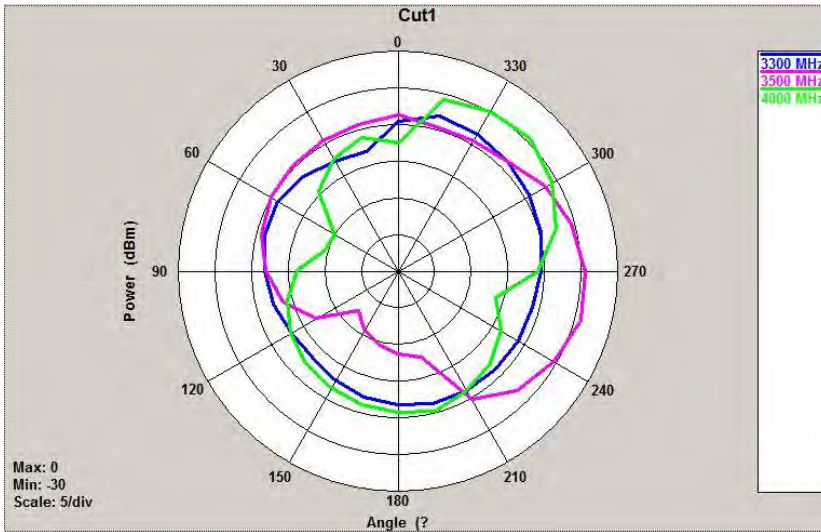

XZ

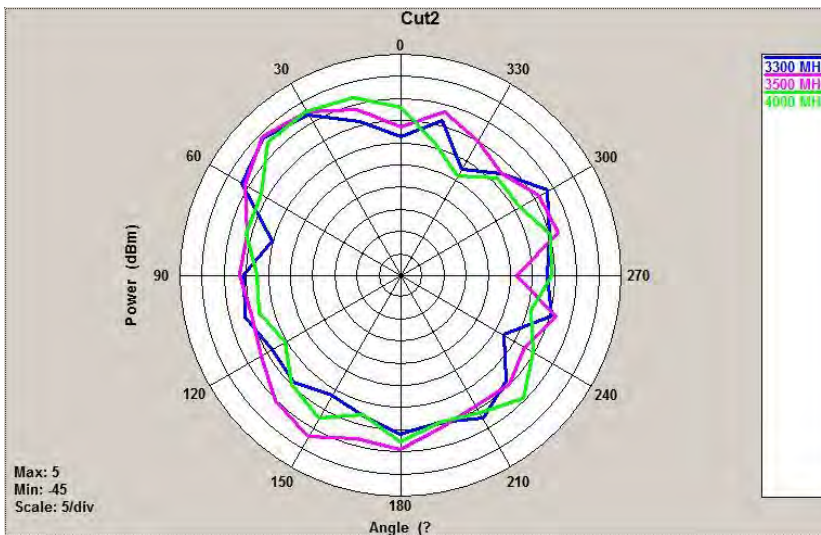

YZ

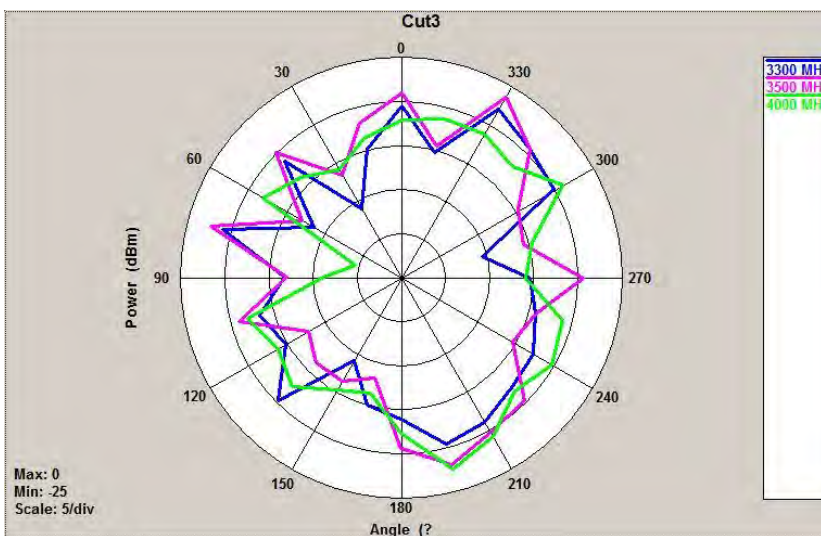

Ant 7(UHB)_3500MHz

XY

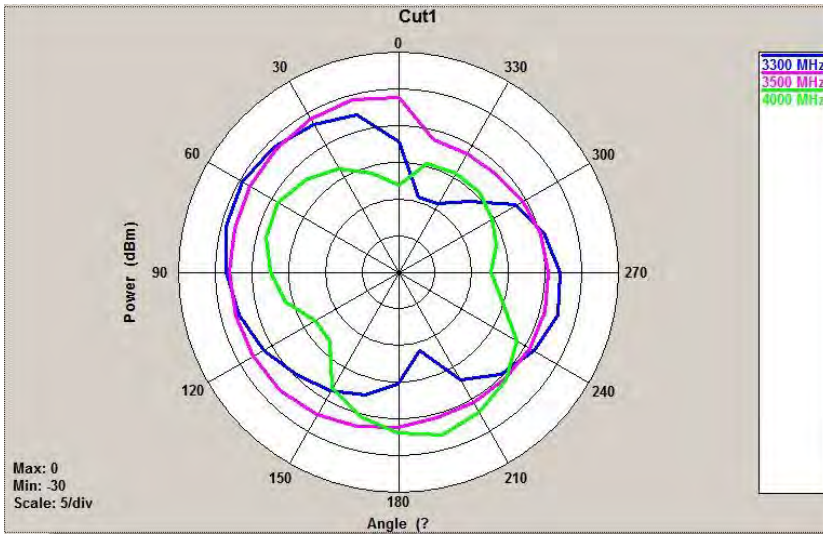

XZ

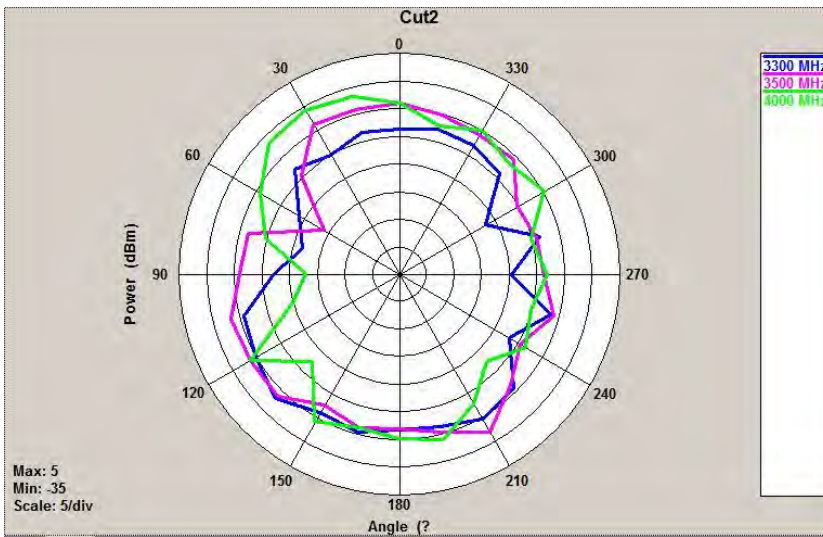

YZ

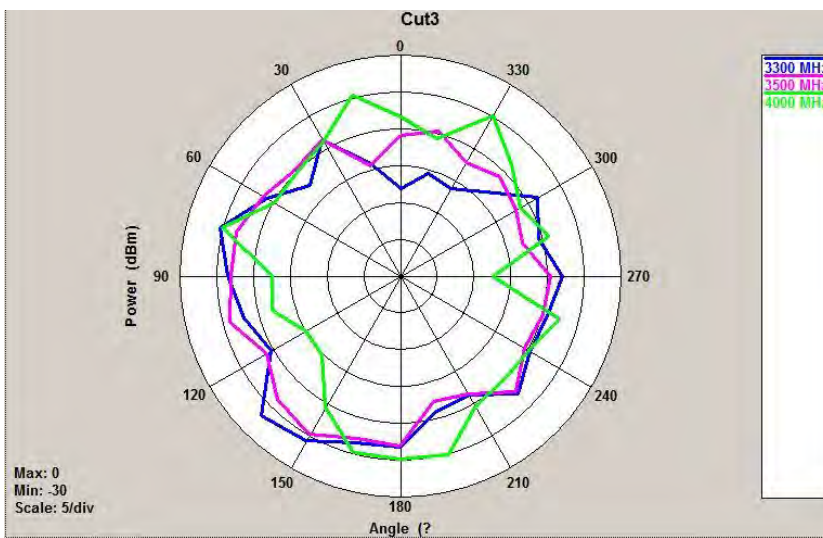

Ant 8(GPS L1+WIFI)_1575MHz

XY

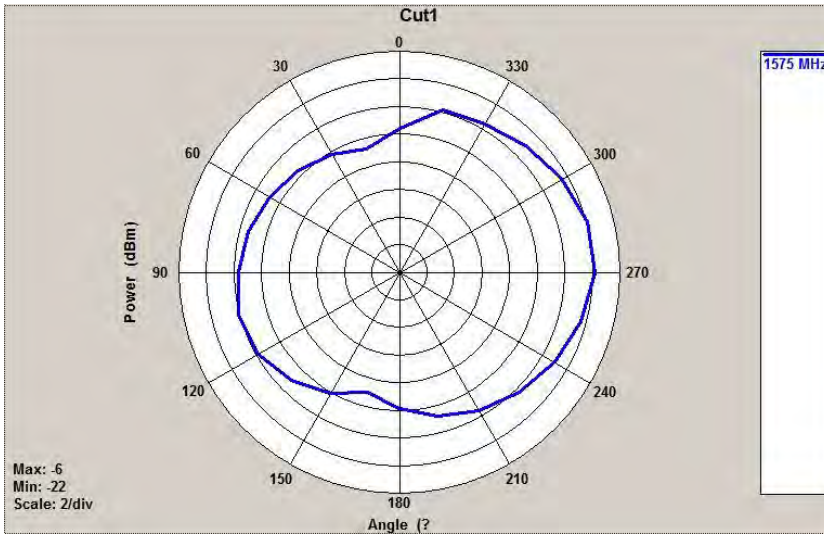

XZ

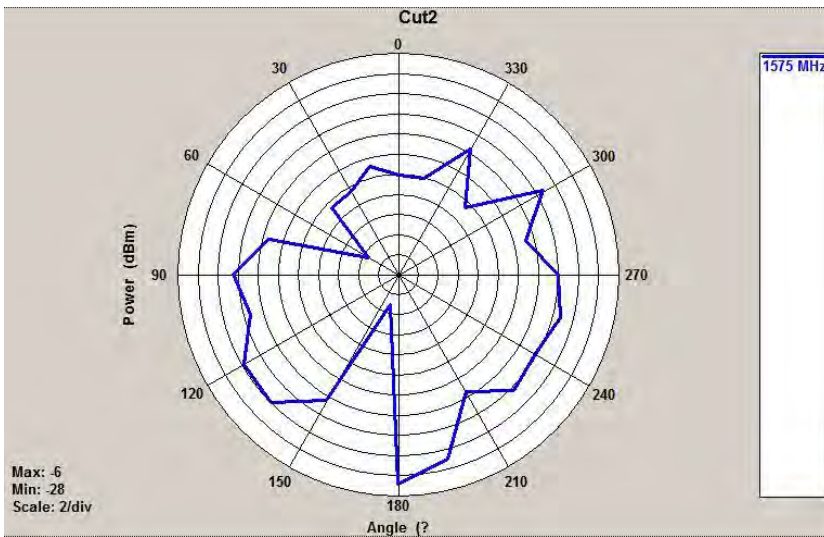

YZ

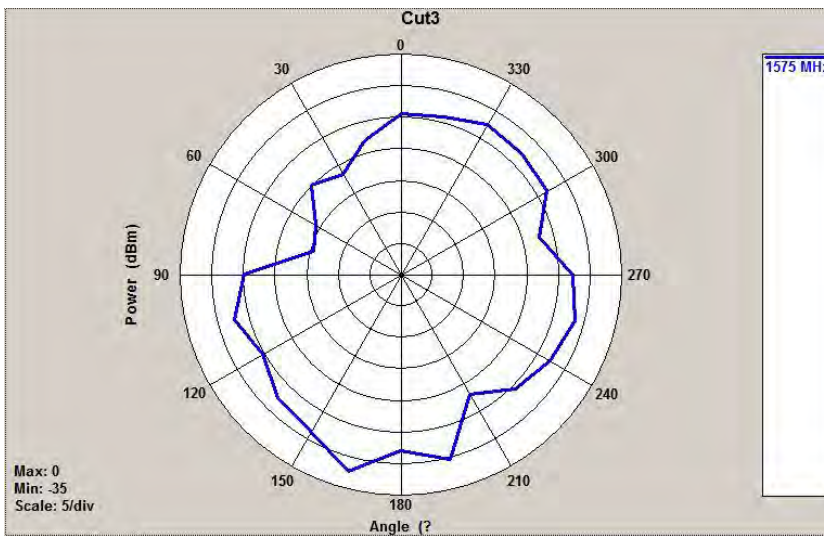

Ant 8(GPS L1+WIFI)_2450MHz

XY

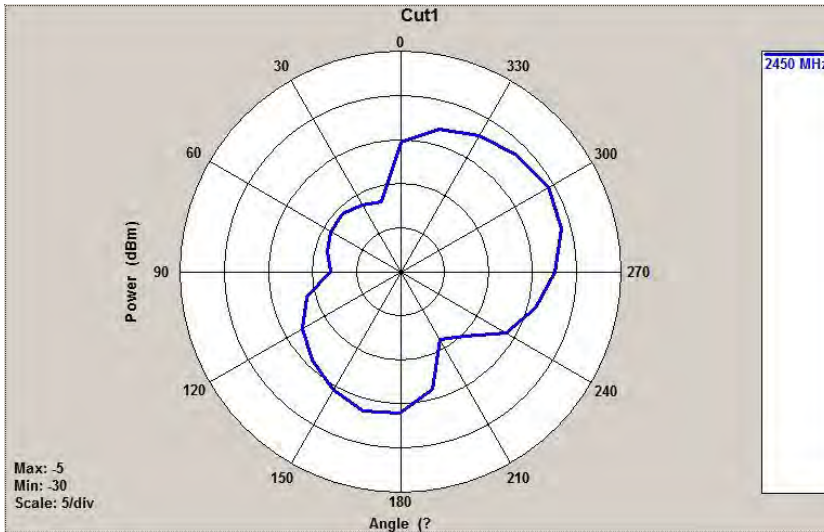

XZ

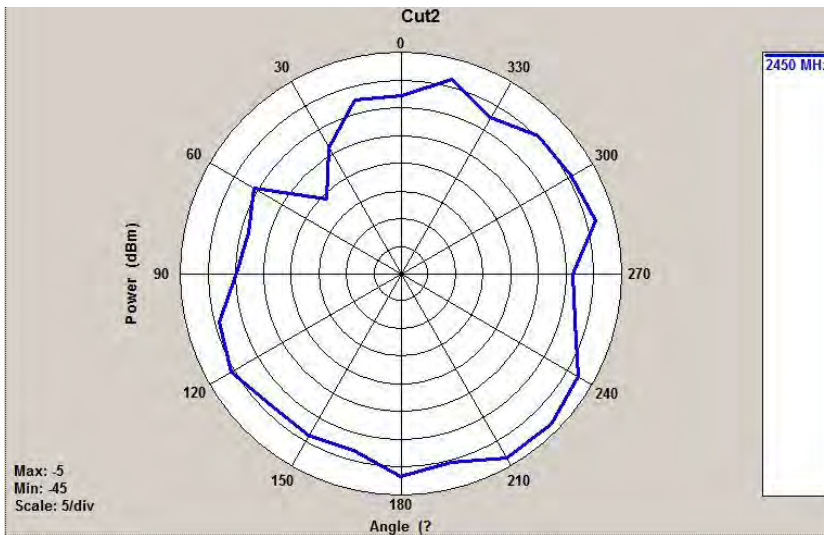

YZ

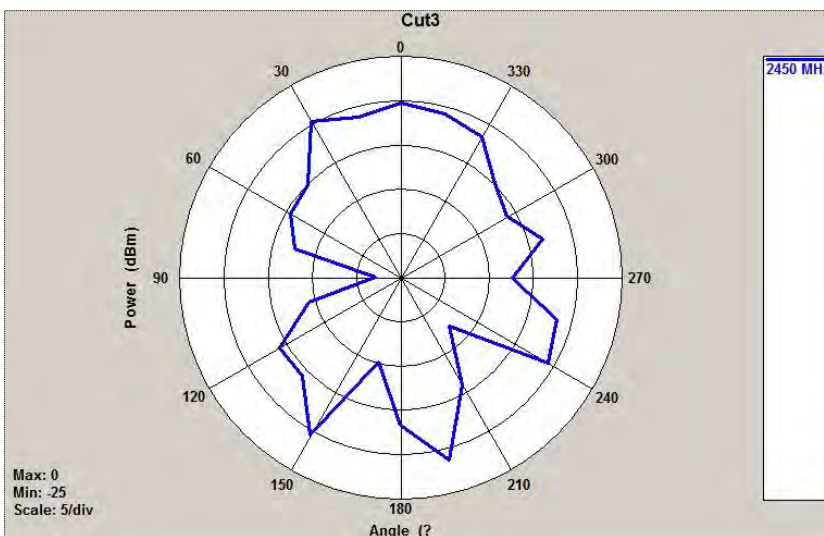

Ant 8(GPS L1+WIFI)_5500MHz_6500MHz

XY

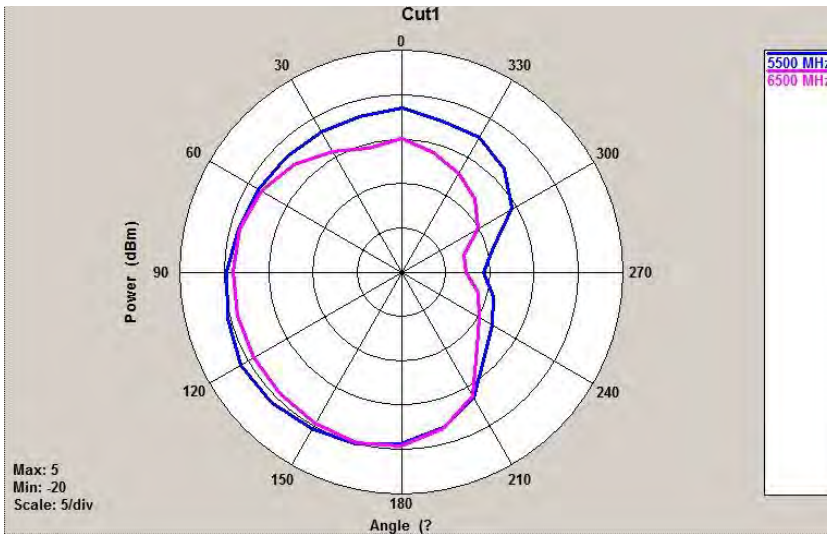

XZ

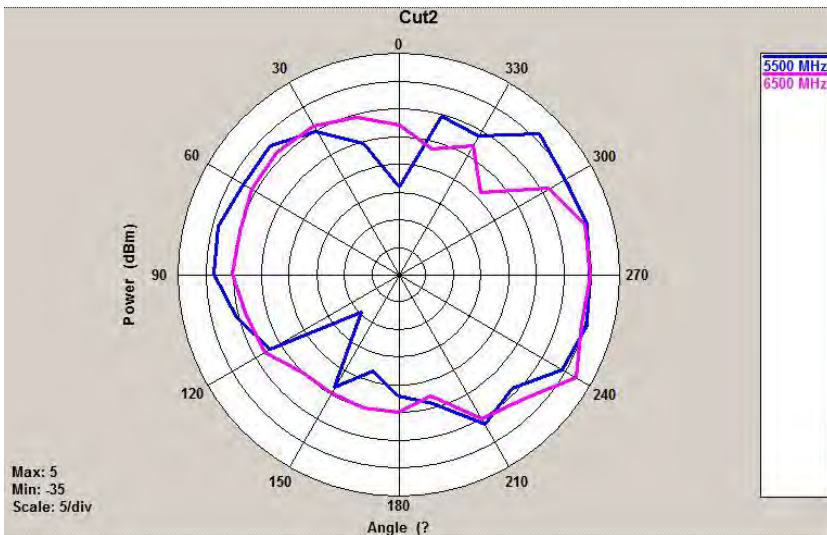

YZ

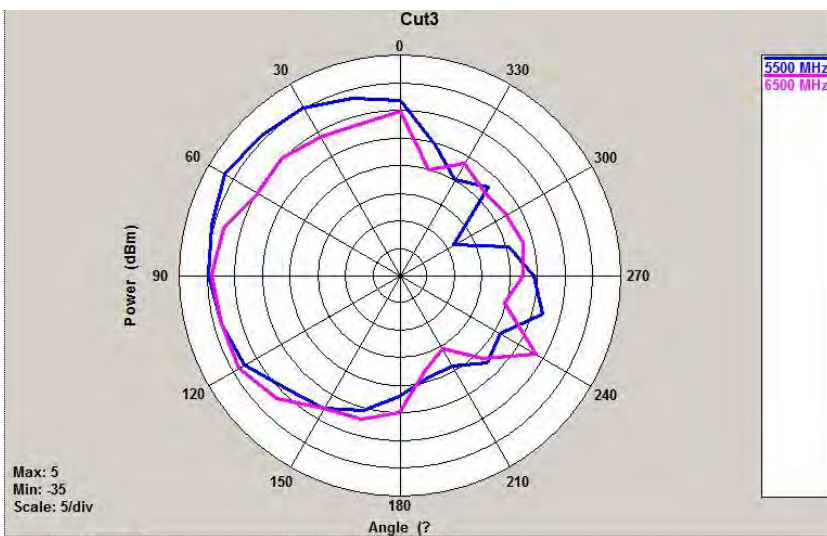

Ant 9(WIFI)_2450MHz

XY

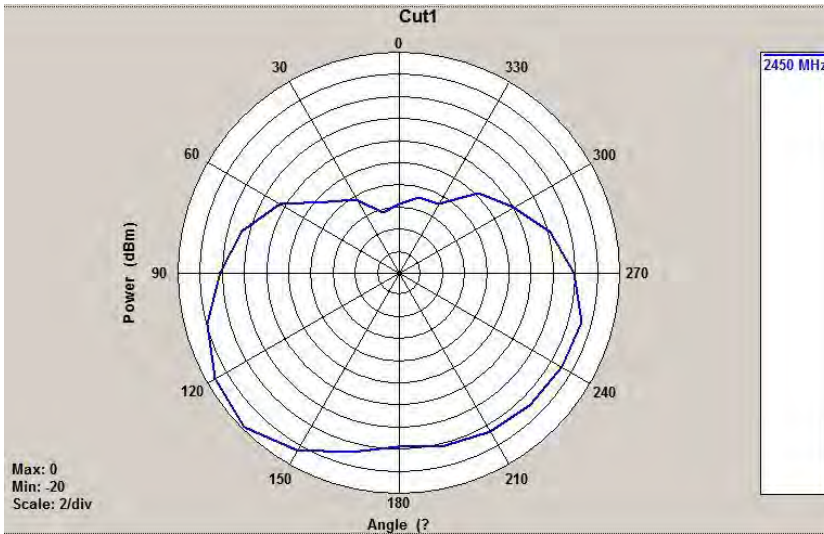

XZ

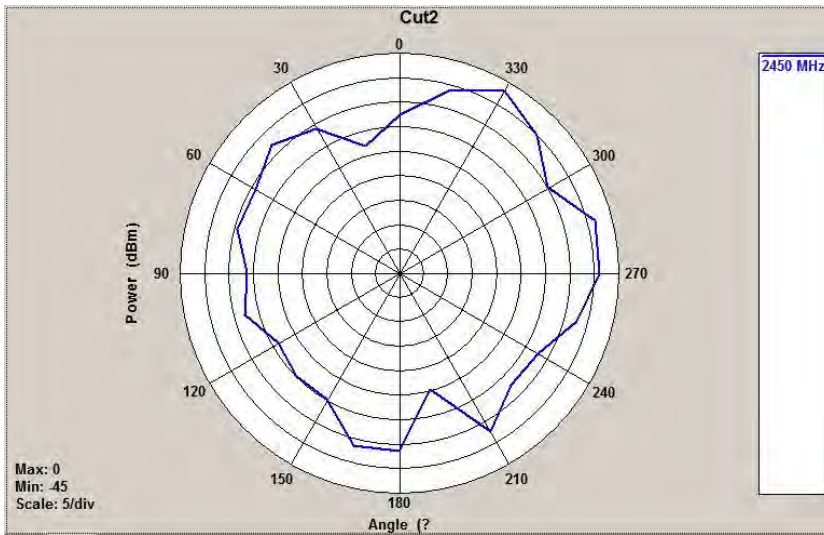

YZ

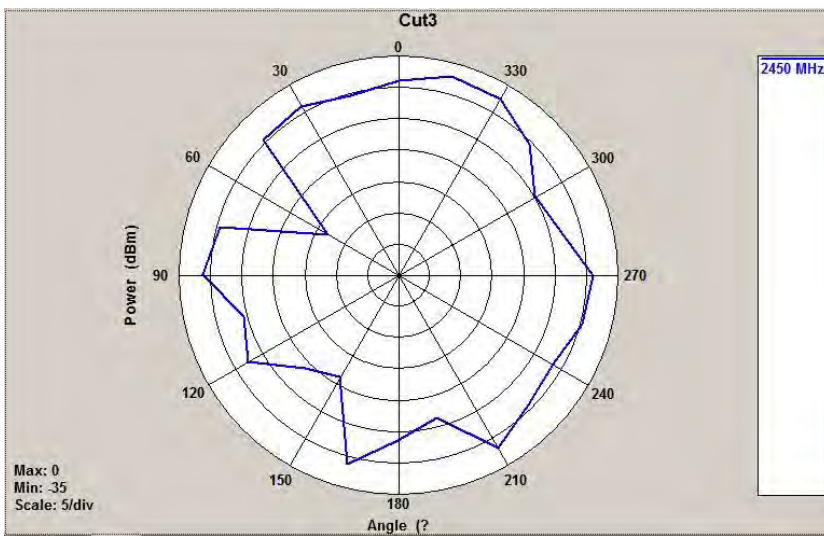

Ant 9(WIFI)_5500MHz_6500MHz

XY

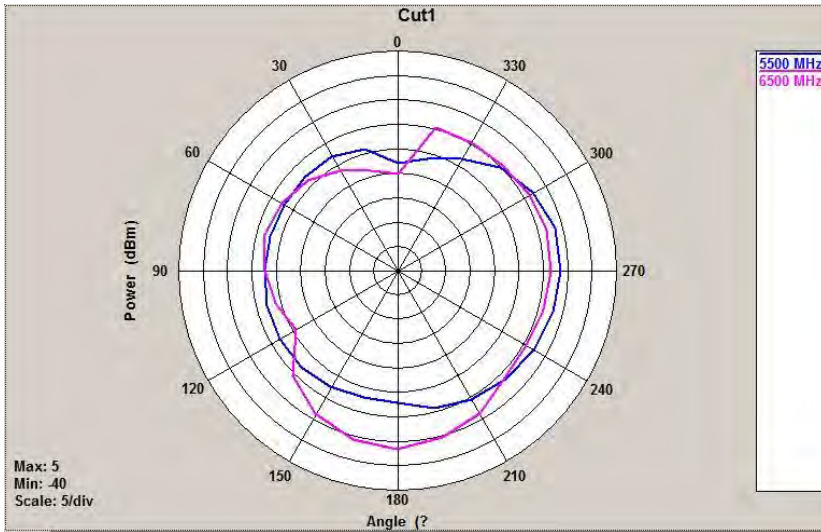

XZ

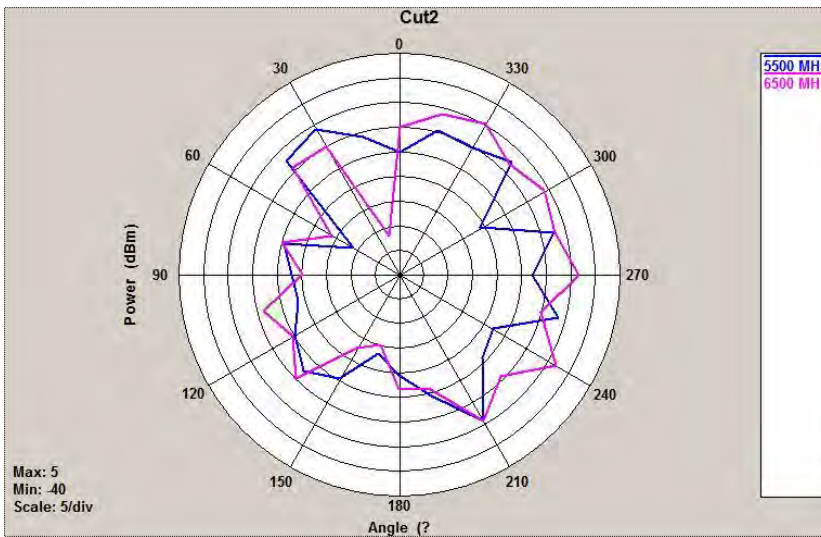

YZ

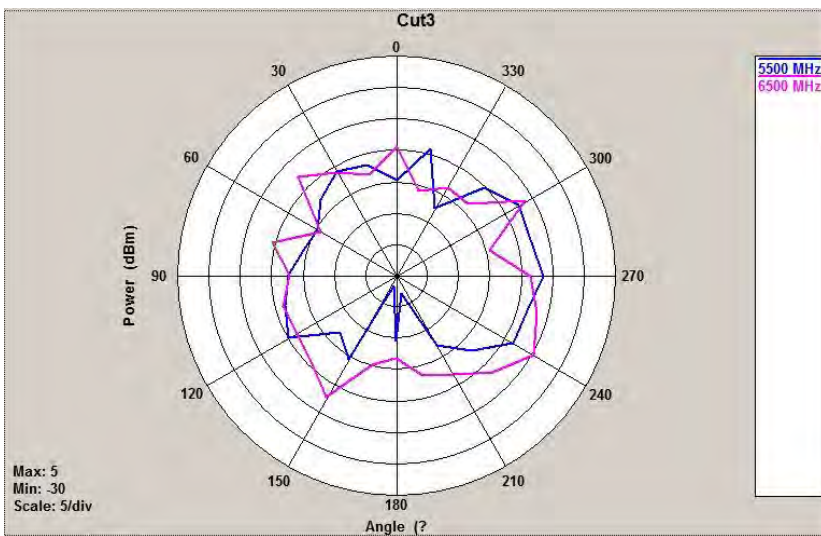

3D Radiation Pattern

Ant 0(LB)_700MHz

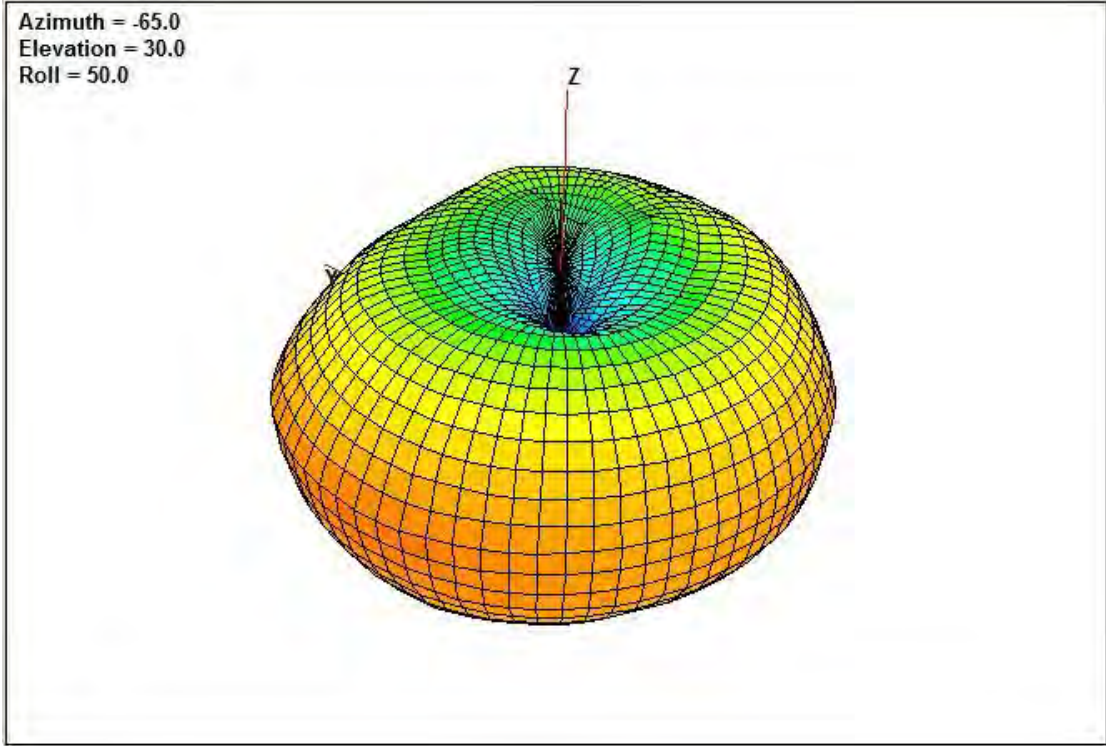
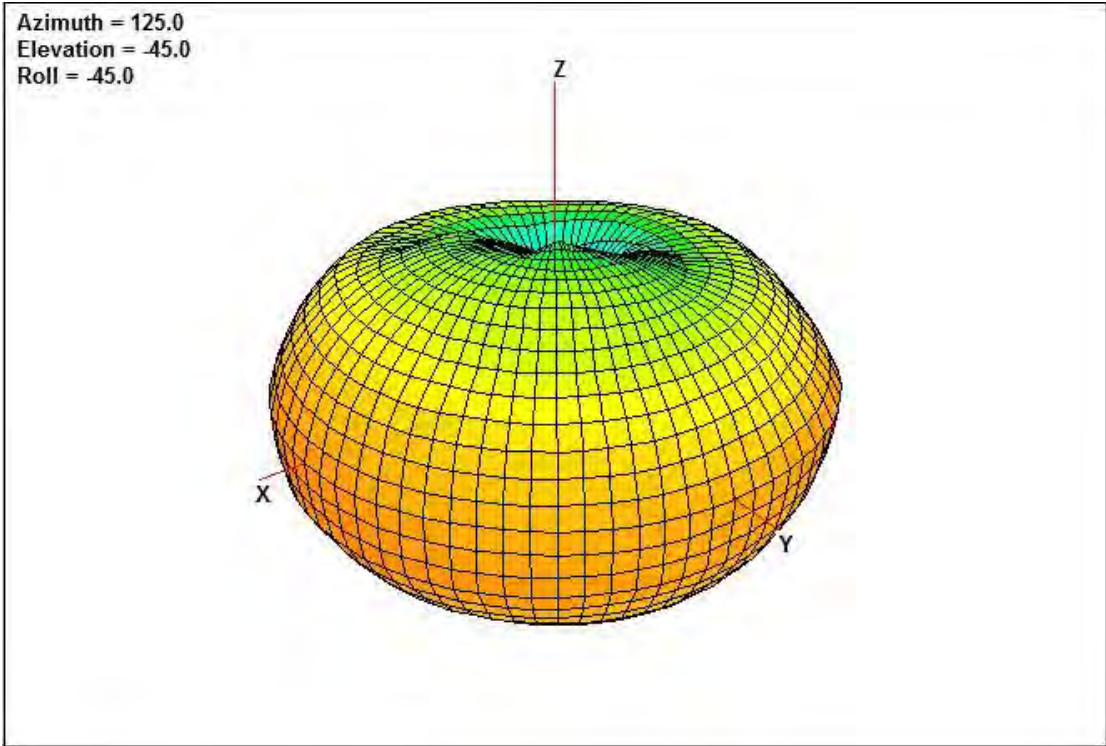

Ant 0(LB)_800MHz

Azimuth = 125.0
Elevation = -45.0
Roll = -45.0

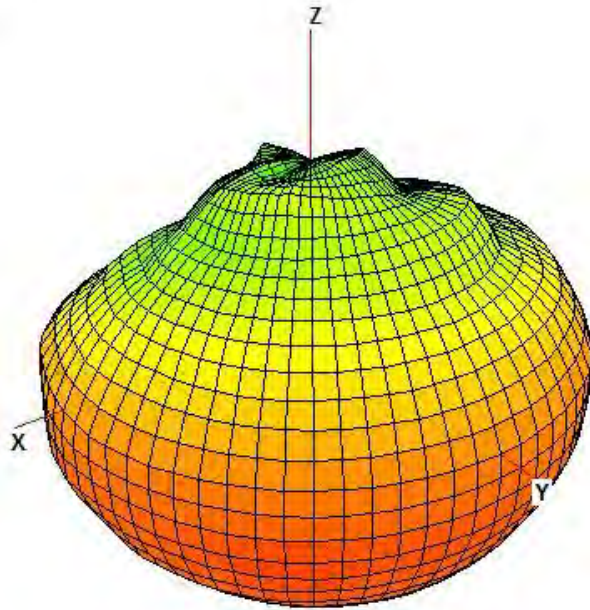

Azimuth = -65.0
Elevation = 30.0
Roll = 50.0

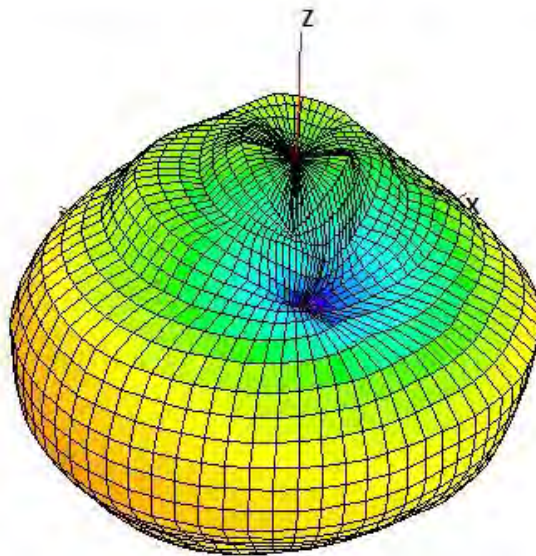

Ant 0(LB)_900MHz

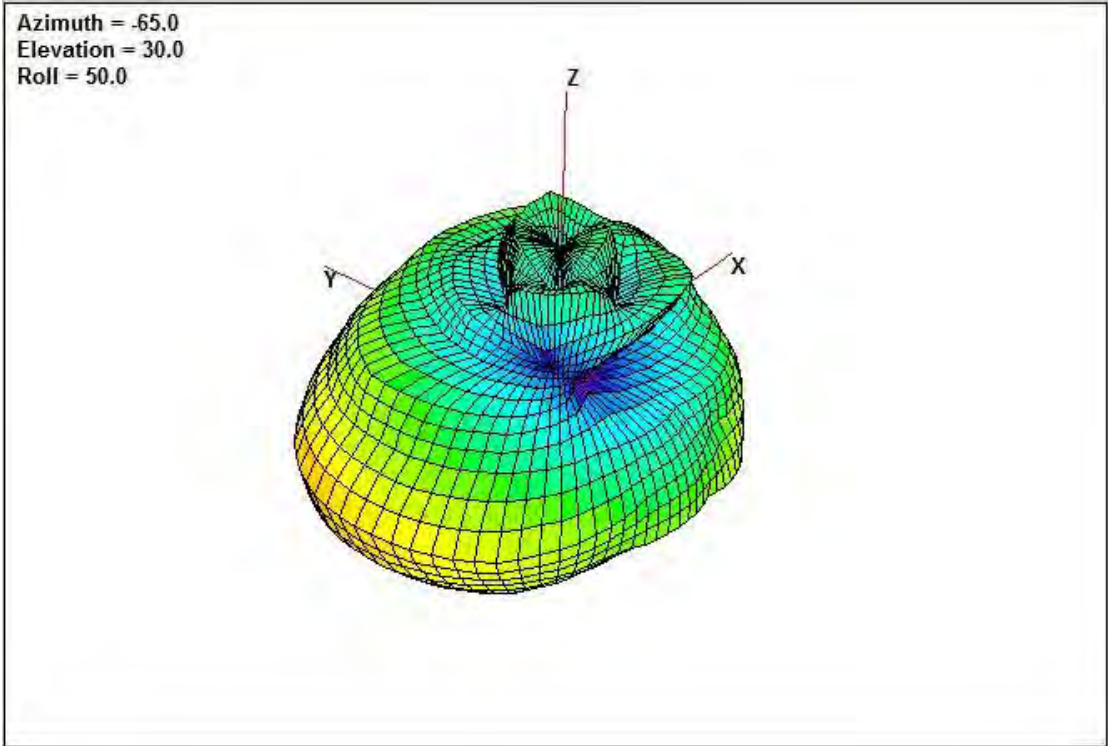
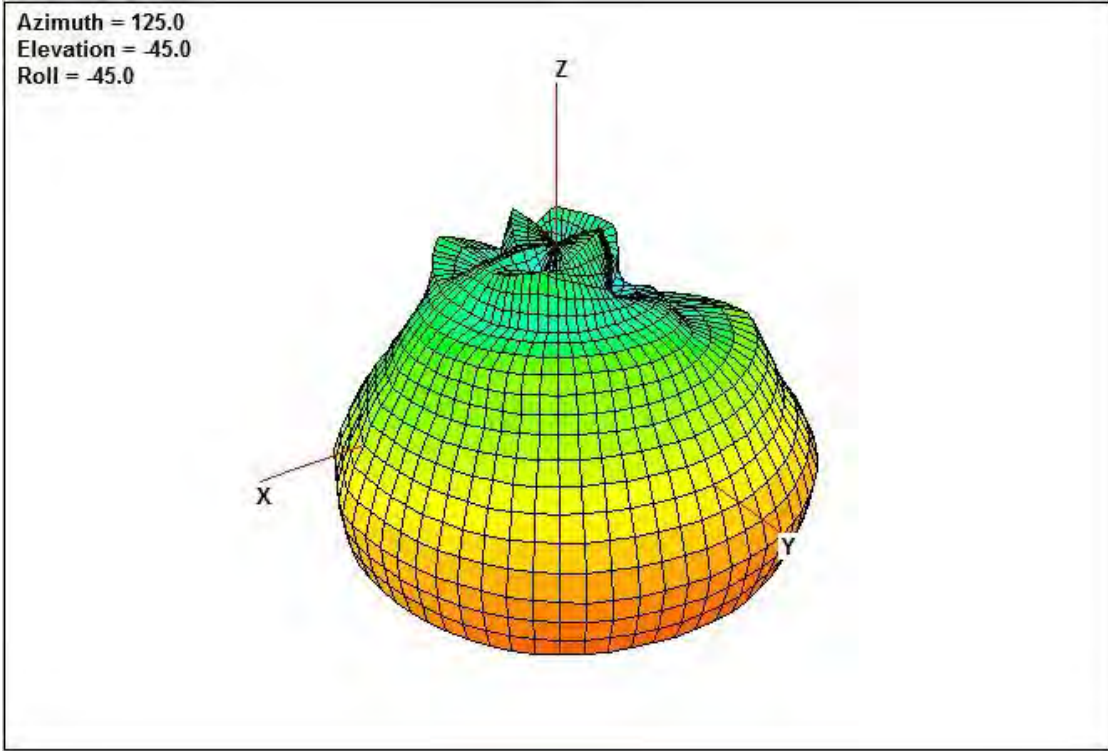

Ant 1(MB+HB)_1710MHz

Azimuth = 125.0
Elevation = -45.0
Roll = -45.0

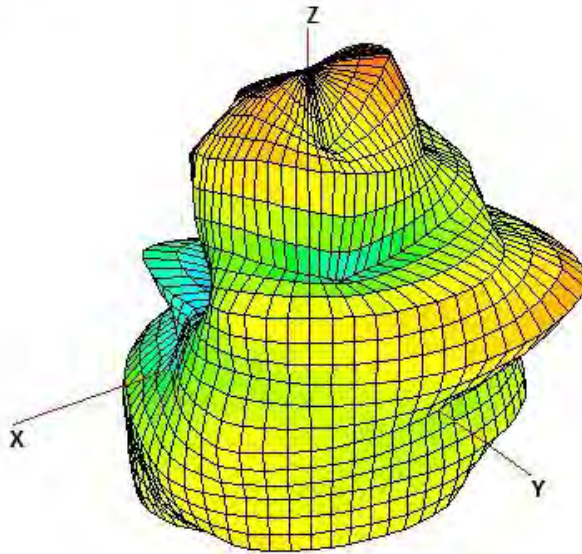

Azimuth = -65.0
Elevation = 30.0
Roll = 50.0

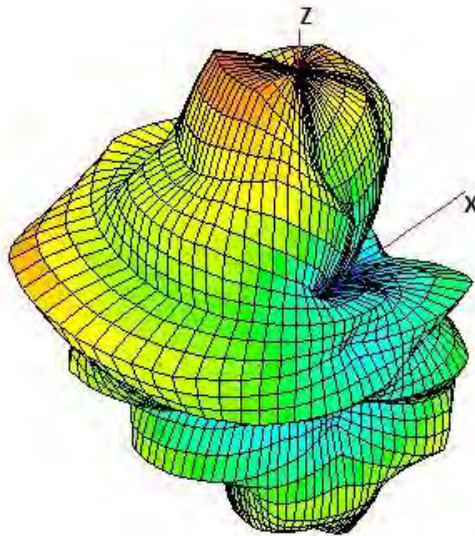

Ant 1(MB+HB)_2170MHz

Azimuth = 125.0
Elevation = -45.0
Roll = -45.0

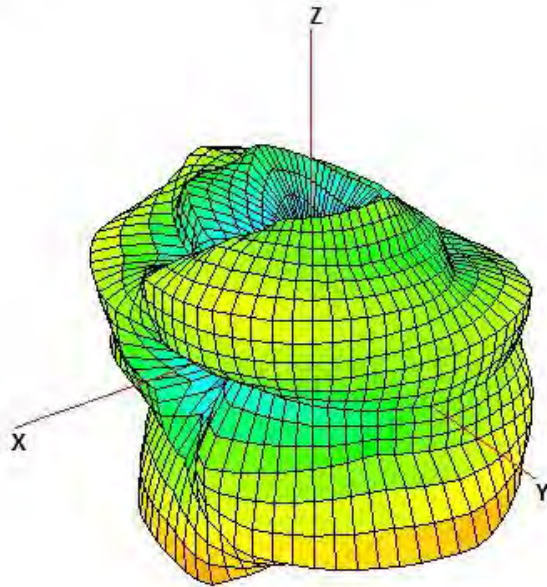

Azimuth = -65.0
Elevation = 30.0
Roll = 50.0

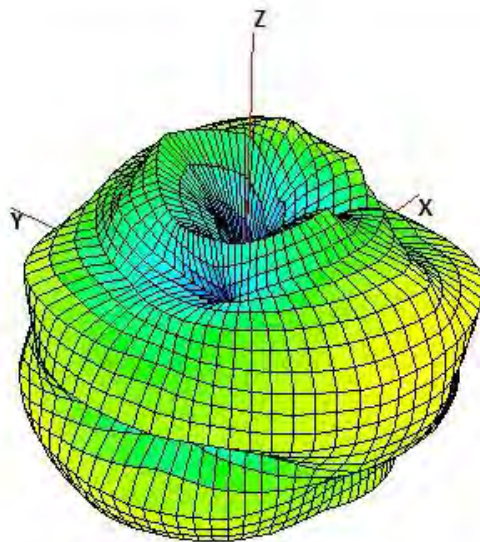

Ant 1(MB+HB)_2300MHz

Azimuth = 125.0
Elevation = -45.0
Roll = -45.0

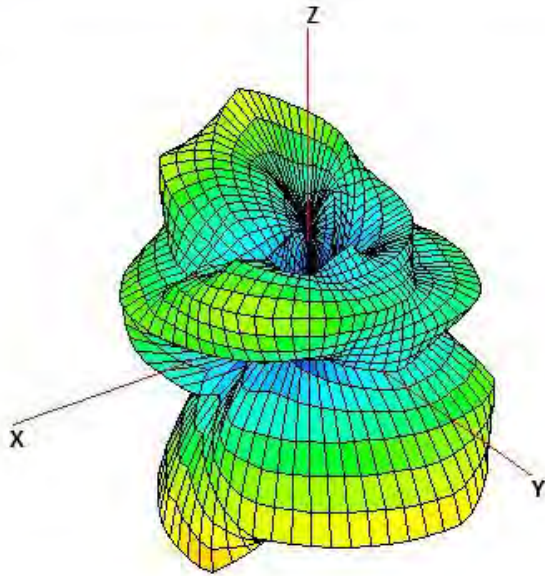

Azimuth = -65.0
Elevation = 30.0
Roll = 50.0

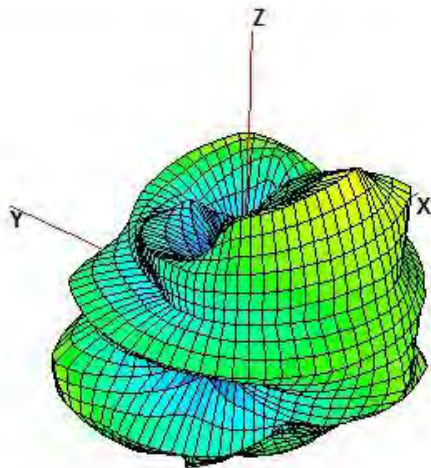

Ant 1(MB+HB)_2600MHz

Azimuth = 125.0
Elevation = -45.0
Roll = -45.0

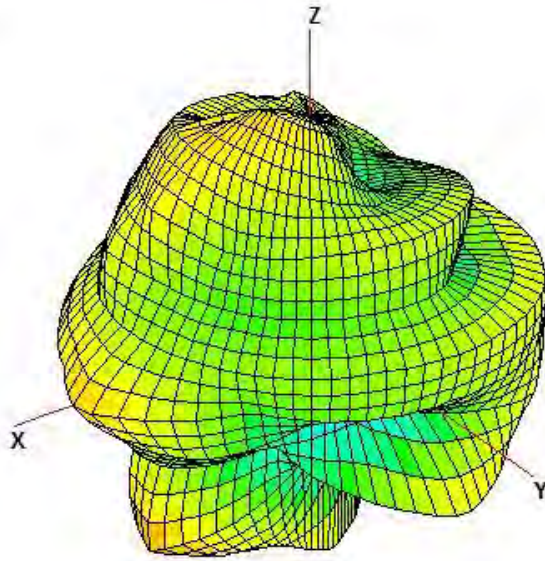

Azimuth = -65.0
Elevation = 30.0
Roll = 50.0

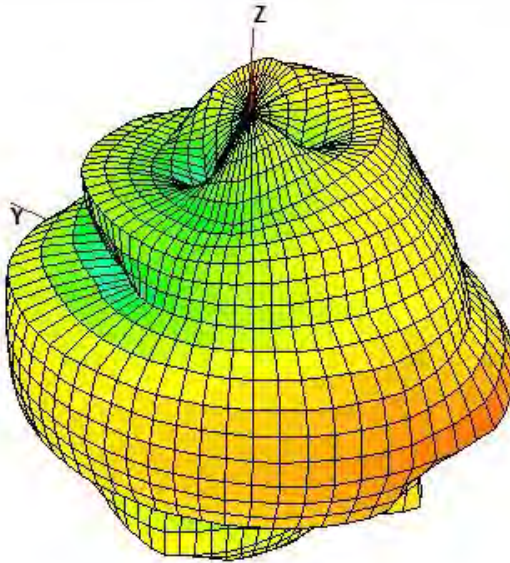

Ant 2+3(LB+MB+HB)_700MHz

Azimuth = 125.0
Elevation = -45.0
Roll = -45.0

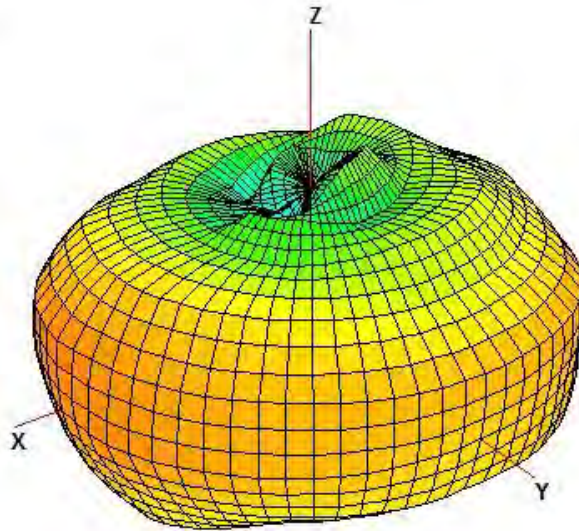

Azimuth = -65.0
Elevation = 30.0
Roll = 50.0

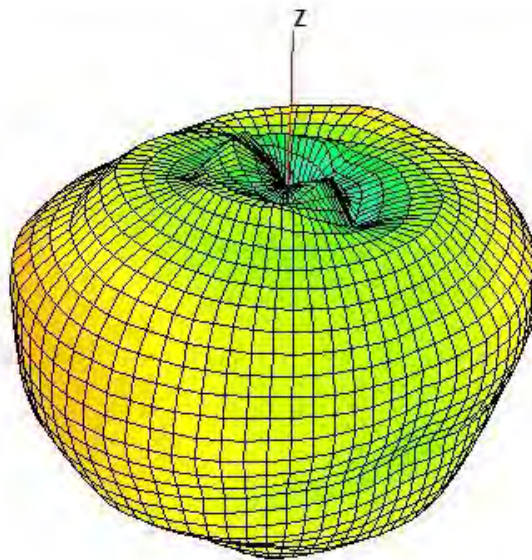

Ant 2+3(LB+MB+HB)_800MHz

Azimuth = 125.0
Elevation = -45.0
Roll = -45.0

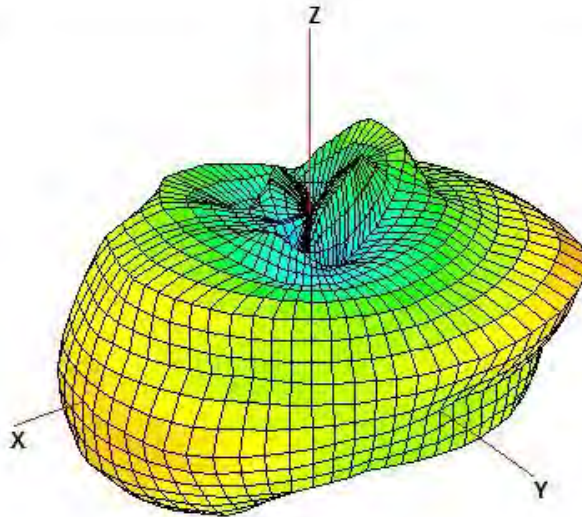

Azimuth = -65.0
Elevation = 30.0
Roll = 50.0

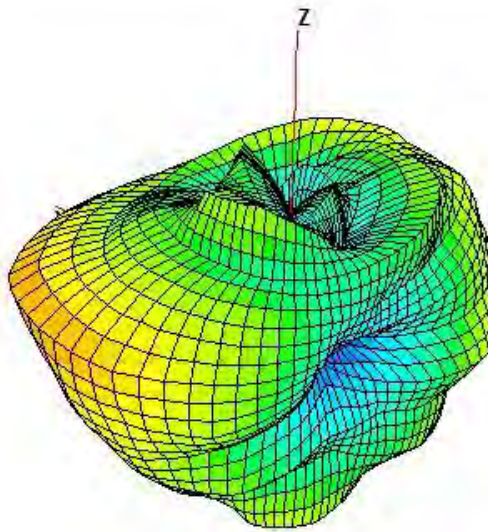

Ant 2+3(LB+MB+HB)_900MHz

Azimuth = 125.0
Elevation = -45.0
Roll = -45.0

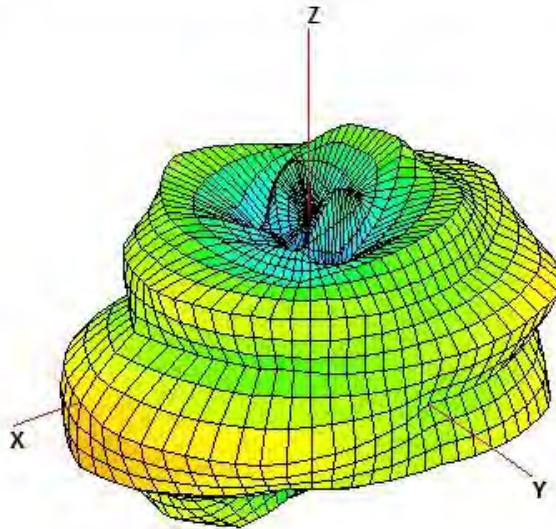

Azimuth = -65.0
Elevation = 30.0
Roll = 50.0

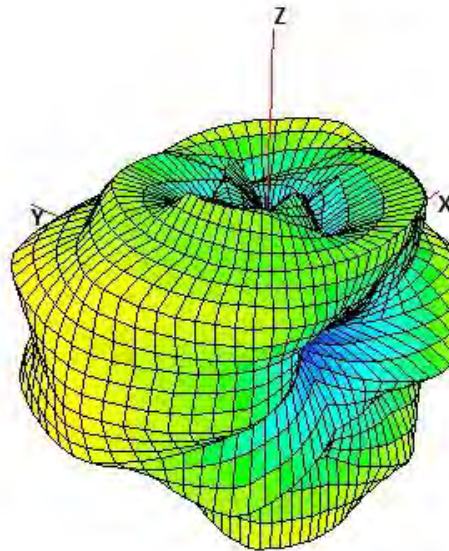

Ant 2+3(LB+MB+HB)_1700MHz

Azimuth = 125.0
Elevation = -45.0
Roll = -45.0

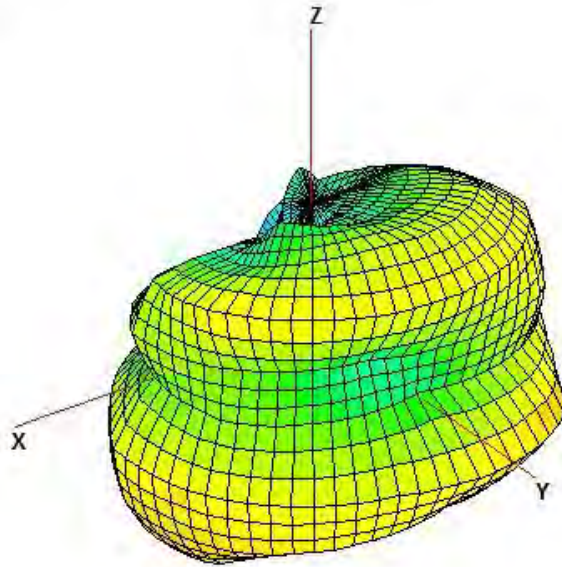

Azimuth = -65.0
Elevation = 30.0
Roll = 50.0

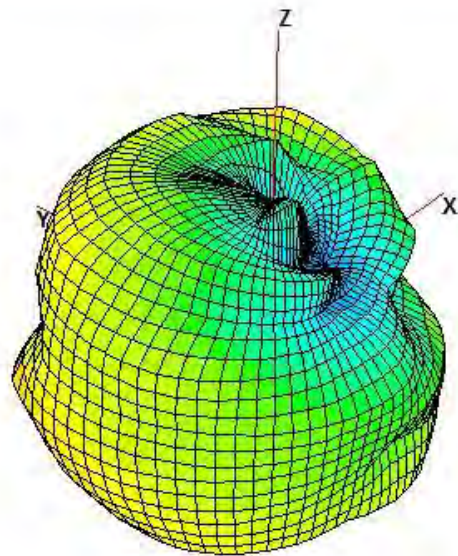

Ant 2+3(LB+MB+HB)_2170MHz

Azimuth = 125.0
Elevation = -45.0
Roll = -45.0

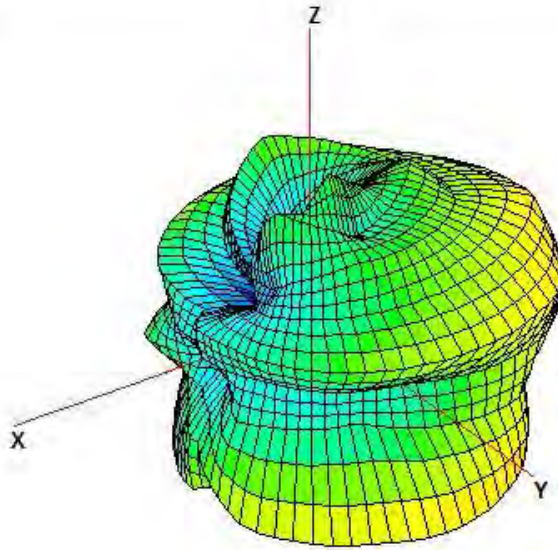

Azimuth = -65.0
Elevation = 30.0
Roll = 50.0

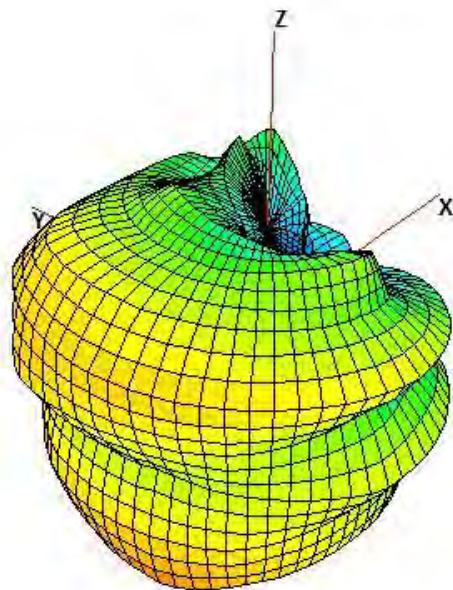

Ant 2+3(LB+MB+HB)_2300MHz

Azimuth = 125.0
Elevation = -45.0
Roll = -45.0

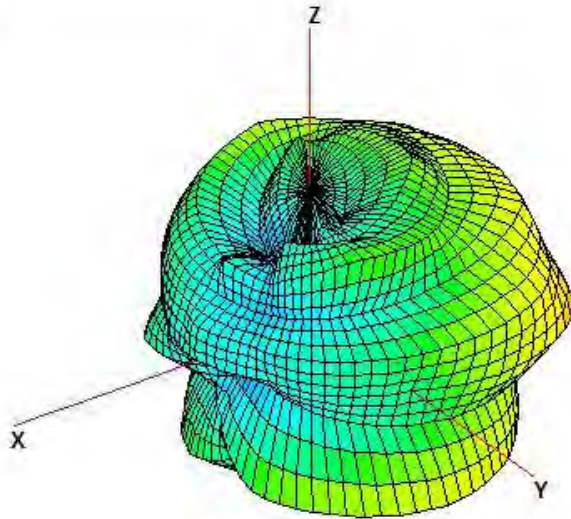

Azimuth = -65.0
Elevation = 30.0
Roll = 50.0

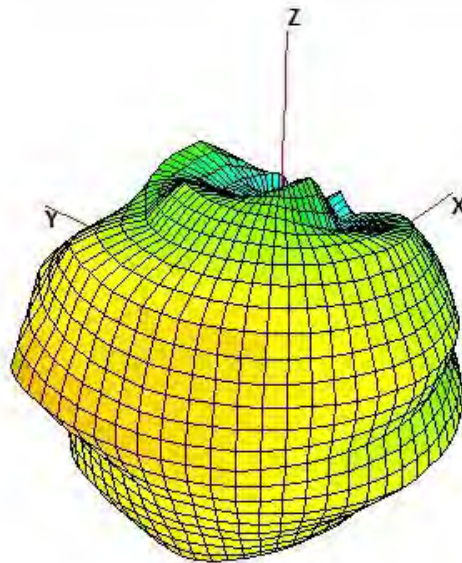

Ant 2+3(LB+MB+HB)_2600MHz

Azimuth = 125.0
Elevation = -45.0
Roll = -45.0

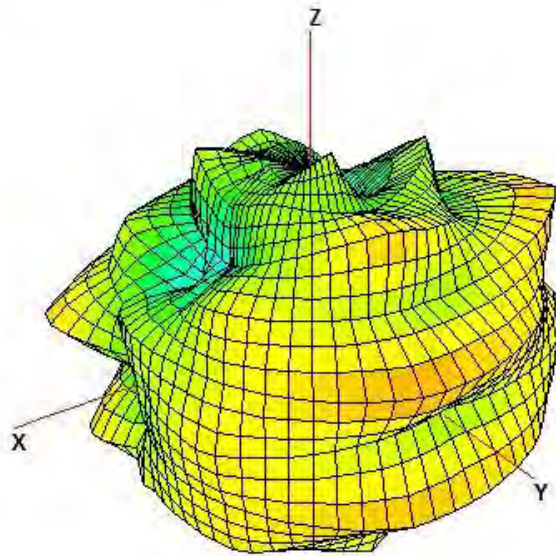

Azimuth = -65.0
Elevation = 30.0
Roll = 50.0

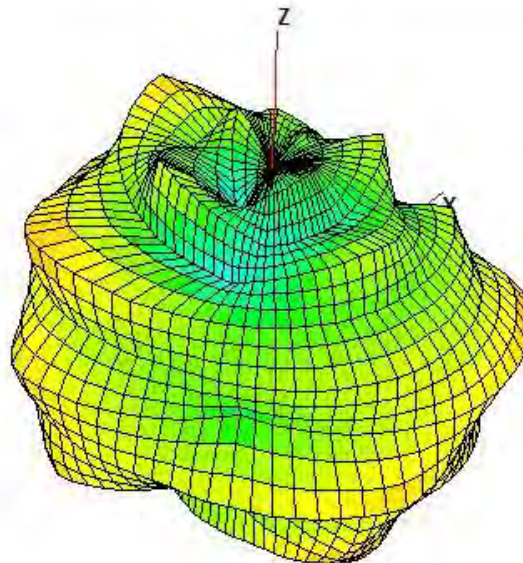

Ant 4(HB+UHB)_2600MHz

Azimuth = 125.0
Elevation = -45.0
Roll = -45.0

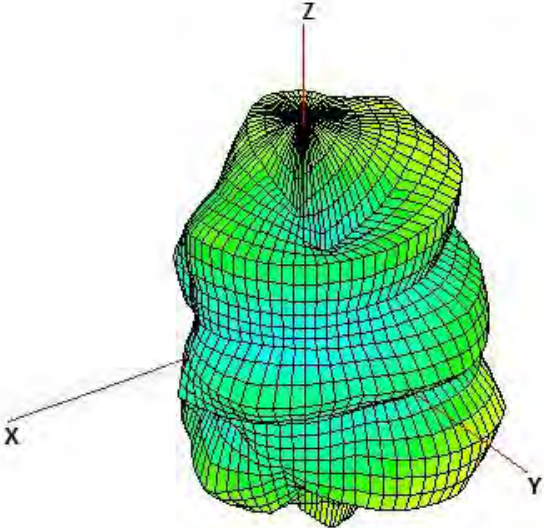

Azimuth = -65.0
Elevation = 30.0
Roll = 50.0

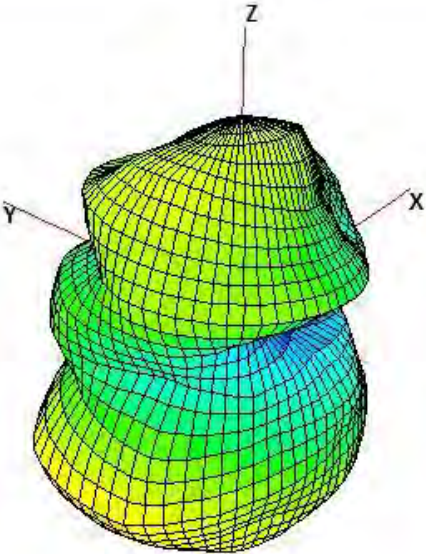

Ant 4(HB+UHB)_3500MHz

Azimuth = 125.0
Elevation = -45.0
Roll = -45.0

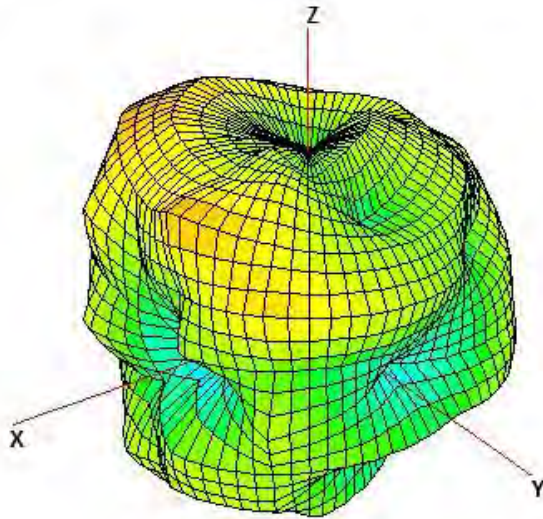

Azimuth = -65.0
Elevation = 30.0
Roll = 50.0

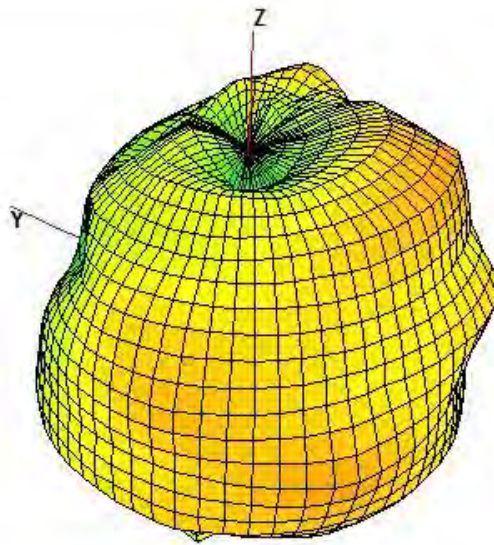

Ant 5(HB+UHB)_2600MHz

Azimuth = 125.0
Elevation = -45.0
Roll = -45.0

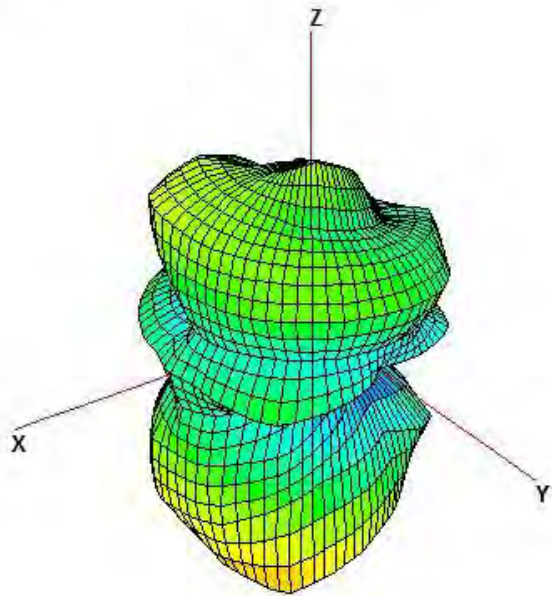

Azimuth = -65.0
Elevation = 30.0
Roll = 50.0

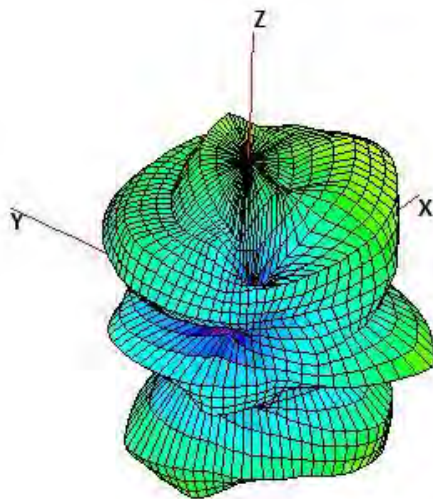

Ant 5(HB+UHB)_3500MHz

Azimuth = 125.0
Elevation = -45.0
Roll = -45.0

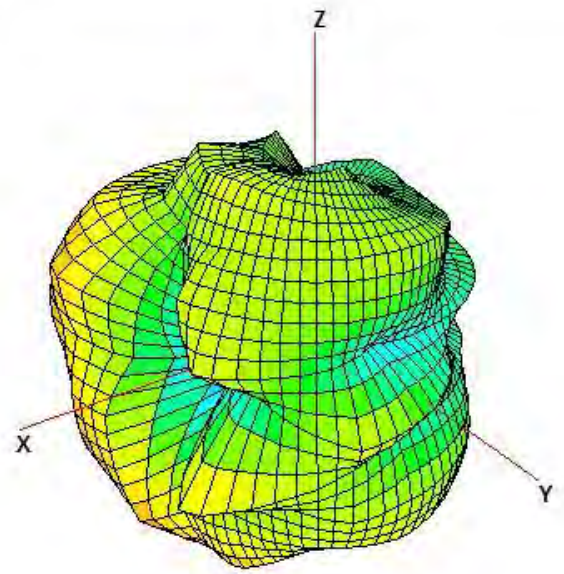

Azimuth = -65.0
Elevation = 30.0
Roll = 50.0

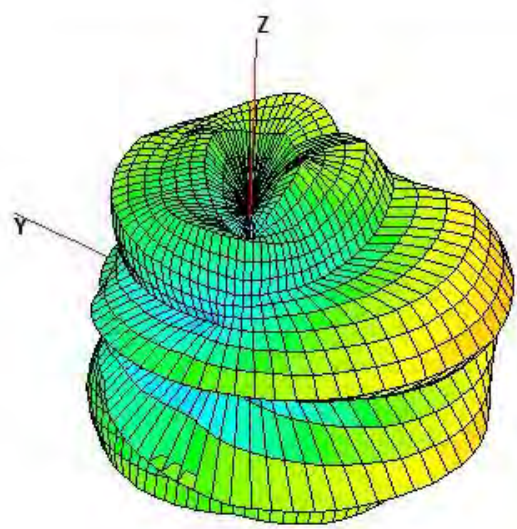

Ant 6(UHB)_3500MHz

Azimuth = 125.0
Elevation = -45.0
Roll = -45.0

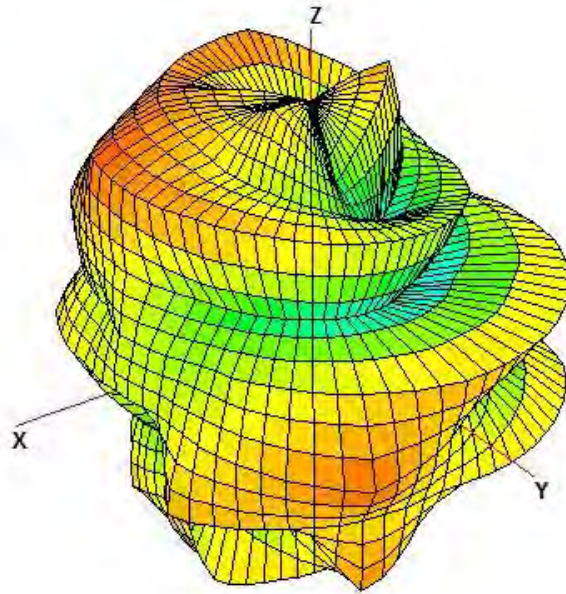

Azimuth = -65.0
Elevation = 30.0
Roll = 50.0

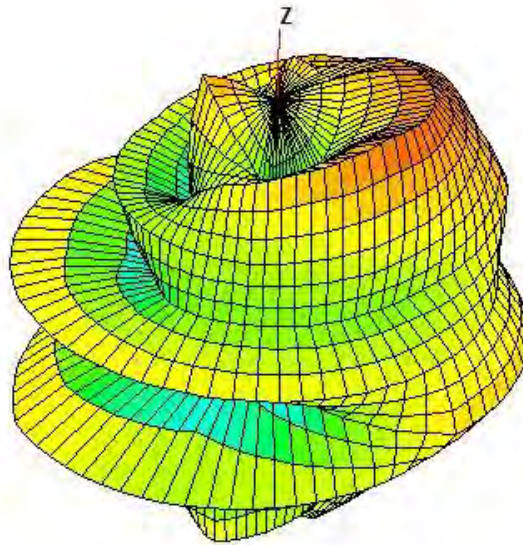

Ant 7(UHB)_3500MHz

Azimuth = 125.0
Elevation = -45.0
Roll = -45.0

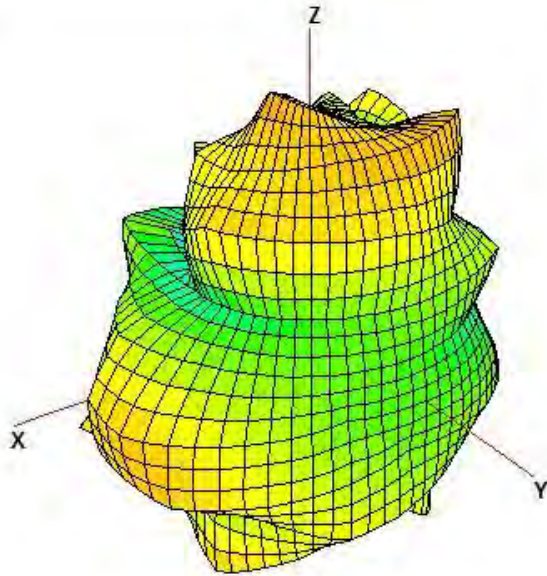

Azimuth = -65.0
Elevation = 30.0
Roll = 50.0

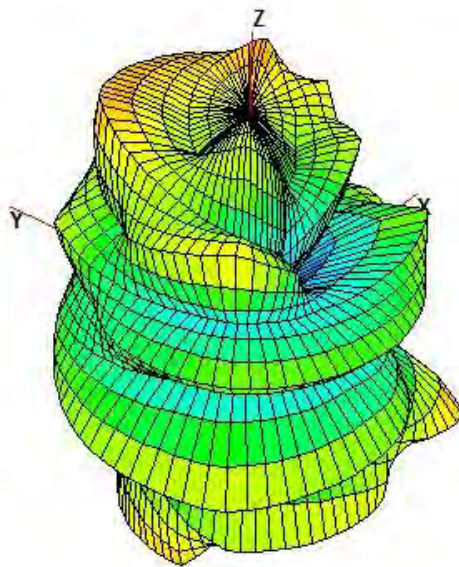

Ant 8(GPS L1+WIFI)_1575MHz

Azimuth = 125.0
Elevation = -45.0
Roll = -45.0

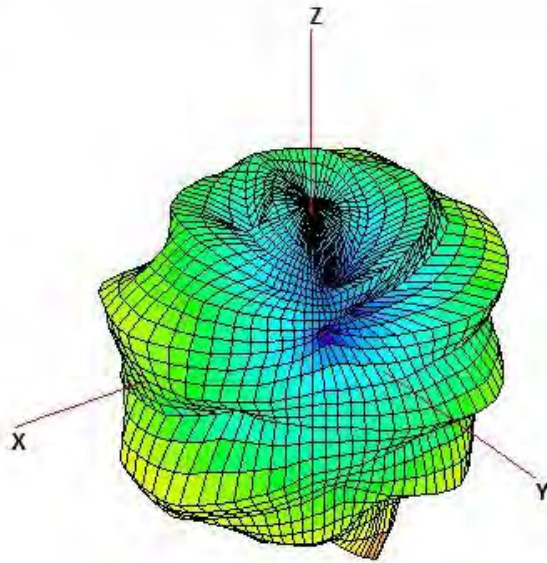

Azimuth = -65.0
Elevation = 30.0
Roll = 50.0

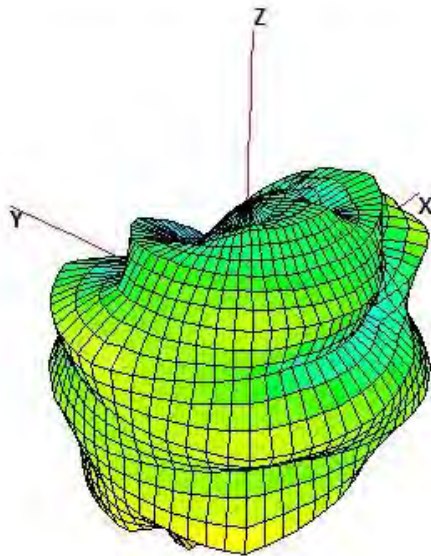

Ant 8(GPS L1+WIFI)_2450MHz

Azimuth = 125.0
Elevation = -45.0
Roll = -45.0

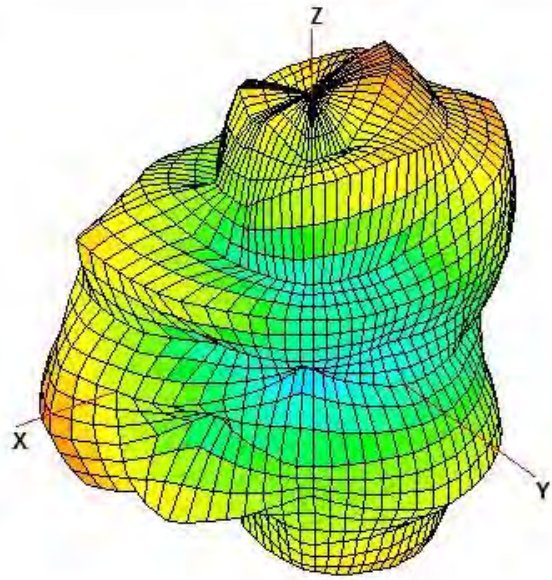

Azimuth = -65.0
Elevation = 30.0
Roll = 50.0

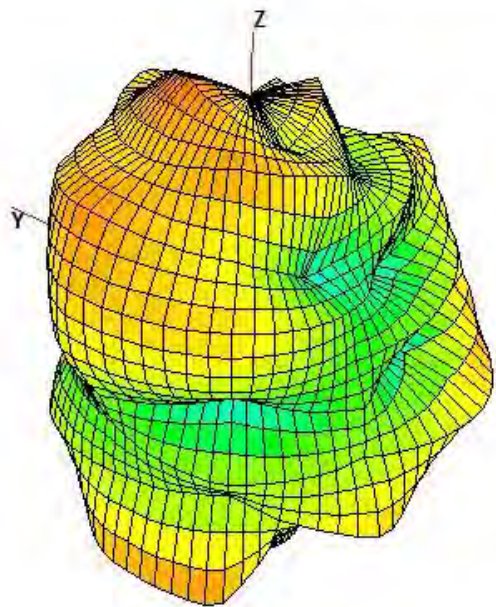

Ant 8(GPS L1+WIFI)_5500MHz

Azimuth = 125.0
Elevation = -45.0
Roll = -45.0

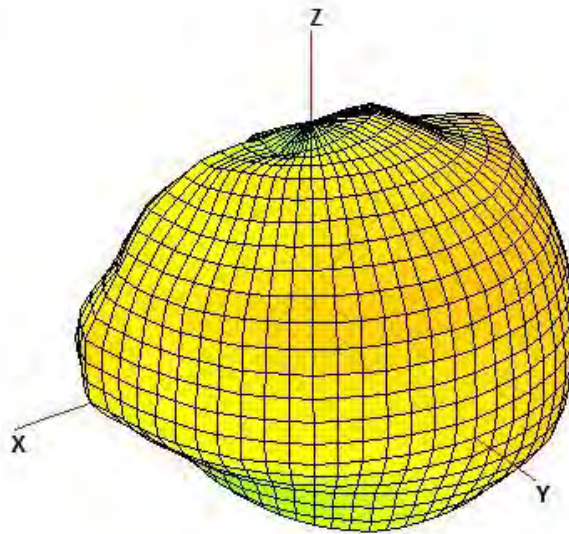

Azimuth = -65.0
Elevation = 30.0
Roll = 50.0

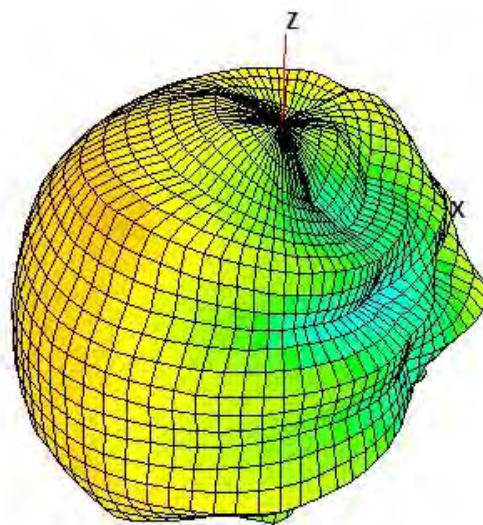

Ant 8(GPS L1+WIFI)_6500MHz

Azimuth = 125.0
Elevation = -45.0
Roll = -45.0

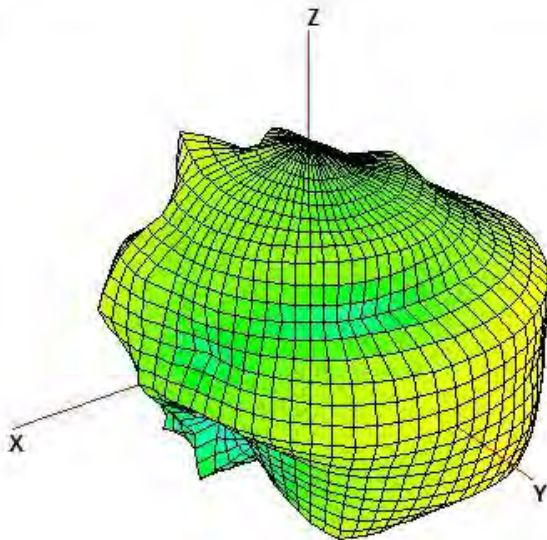

Azimuth = -65.0
Elevation = 30.0
Roll = 50.0

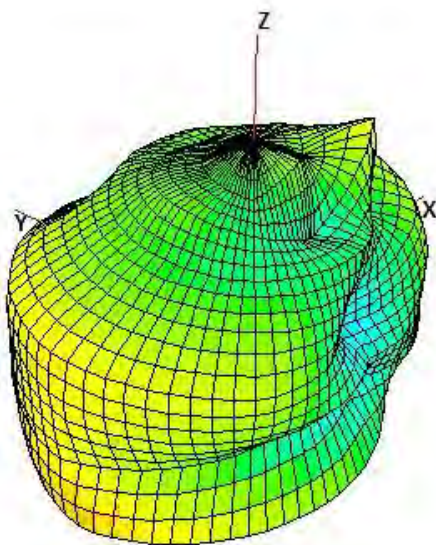

Ant 9(WIFI)_2450MHz

Azimuth = 125.0
Elevation = -45.0
Roll = -45.0

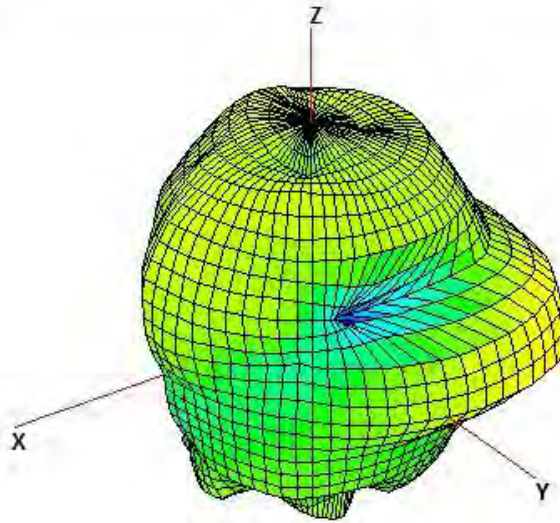

Azimuth = -65.0
Elevation = 30.0
Roll = 50.0

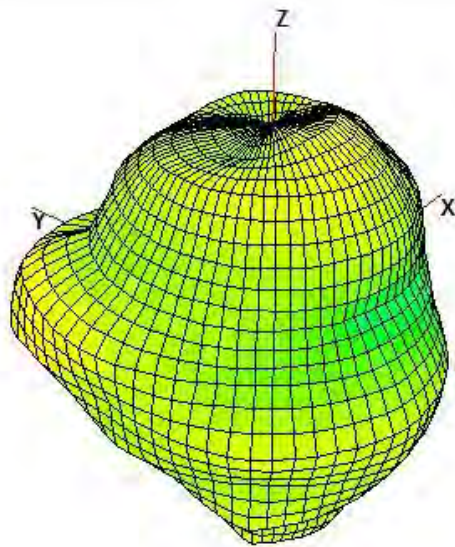

Ant 9(WIFI)_5500MHz

Azimuth = 125.0
Elevation = -45.0
Roll = -45.0

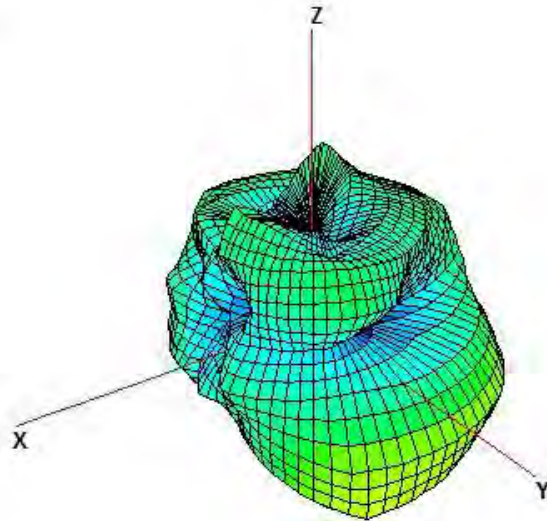

Azimuth = -65.0
Elevation = 30.0
Roll = 50.0

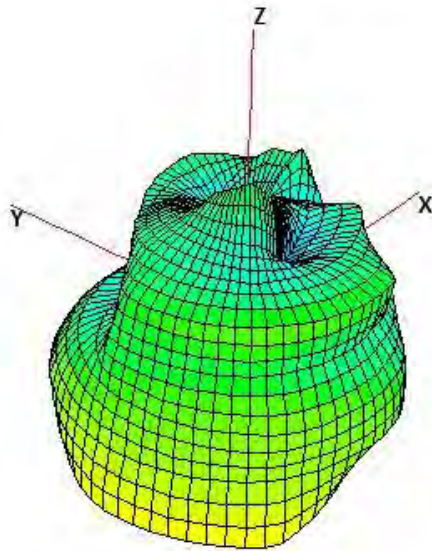

Ant 9(WIFI)_6500MHz

Azimuth = 125.0
Elevation = -45.0
Roll = -45.0

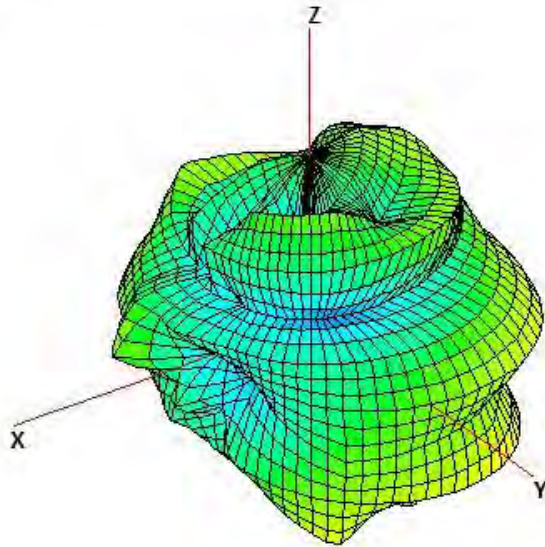

Azimuth = -65.0
Elevation = 30.0
Roll = 50.0

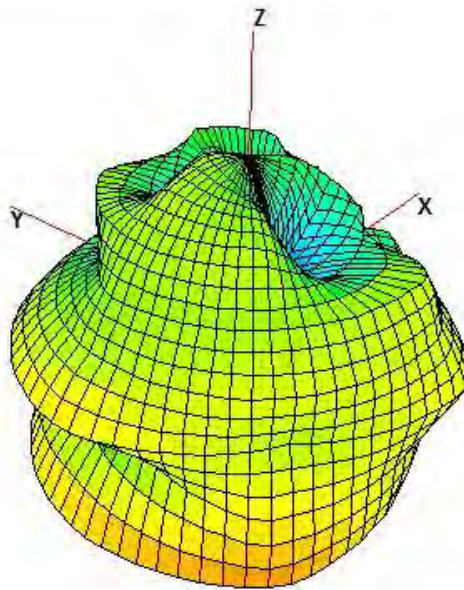

Test Environment & Equipment

Test site: USI ETS Chamber

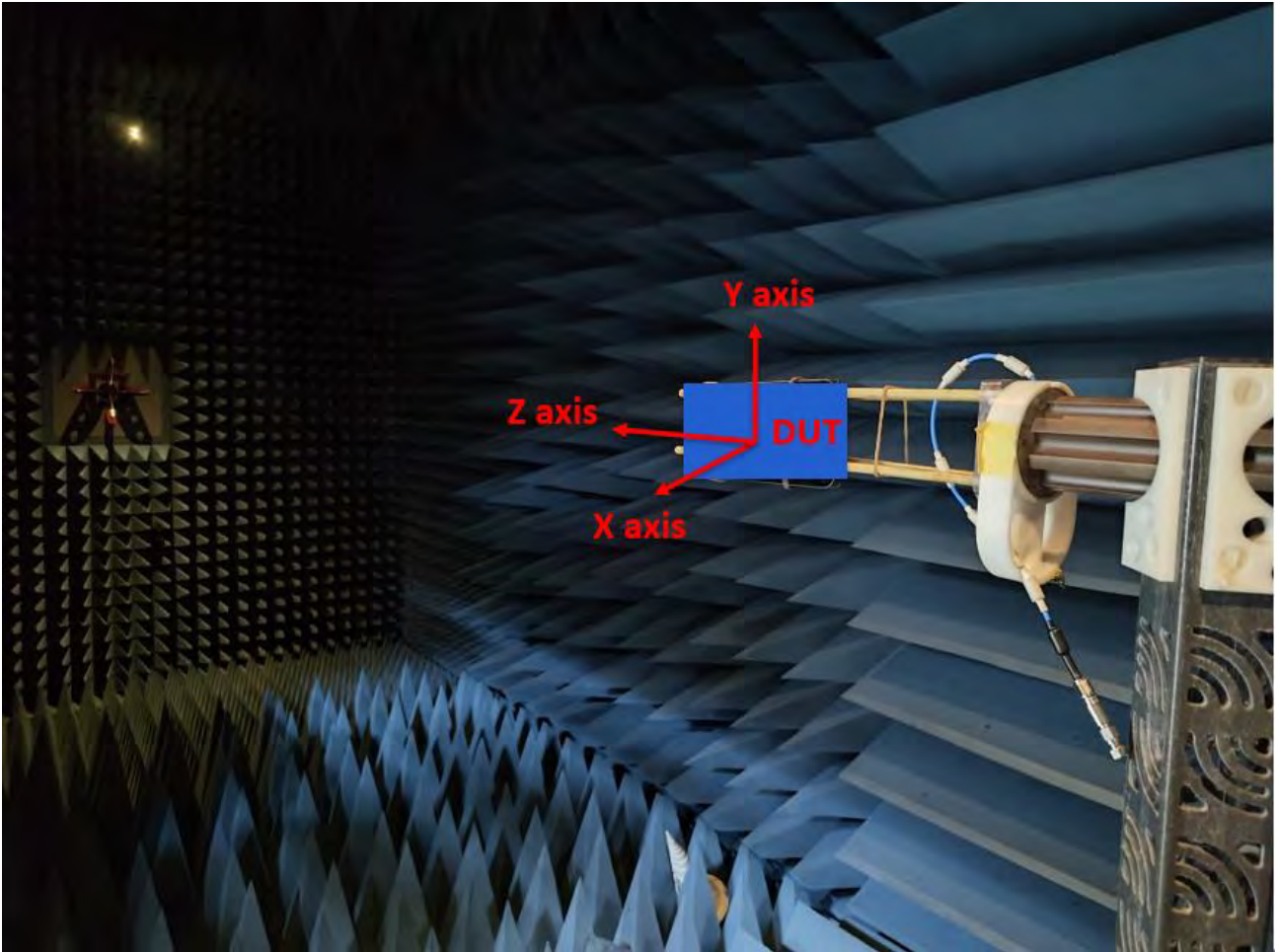

Test & System Description

Equipment Description	Manufacturer	Identification no.	Current calibration date	Next calibration date
Network analyzer	Agilent	E5071C	2023/6/13	2024/6/13
Measurement software	ETS-Lindgren	EMQuest	2023/10/15	2024/10/15
EMCenter	ETS-Lindgren	7000-001	2023/10/15	2024/10/15
Multi-device controller	ETS-Lindgren	Model 2090	2023/10/15	2024/10/15
Horn antenna	ETS-Lindgren	3164-08	2023/10/15	2024/10/15

Measurement Description

ETS-Lindgren J1111 system is 3D fully anechoic chamber, it is applied to the “Conical Cut test method”, the detail description is described as below. The Conical Cut method requires the ability of the Measurement Antenna to be physically rotated in the theta plane (overhead) of the EUT for implementations using a single Measurement Antenna, Eleven conical cuts are required to capture data at every 15 degrees from the EUT, with the top (0 degrees) and bottom (180 degrees) cuts not being measured. Typically, the EUT will remain affixed to a turntable during the entire measurement process. The Measurement Antenna will be positioned at a starting theta angle. The EUT will then be rotated around the full 360 degrees of phi rotation. The Measurement Antenna will then be positioned at the next theta angle, and the process repeated.

Test Date: 2024/03/06

Test Personnel: Tom Chen

Test Software: ETS-Lindgren EMQuest

Test site: USI ETS Chamber

No. 141, Ln. 351, Sec. 1, Taiping Rd., Caotun Township, Nantou County 542007, Taiwan (R.O.C.)

