

FCC TEST REPORT

FCC ID : U4G-Q10SSDL
Equipment : Dock
Brand Name : DATALOGIC
Model Name : DOCK, SINGLE SLOT, CHARGE, MEMOR 20
Applicant/
Manufacturer : DATALOGIC S.R.L.
VIA SAN VITALINO 13 40012 LIPPO DI
CALDERARA DI RENO (BO), ITALY
Standard : 47 CFR FCC Part 15.209

The product was received on Aug. 02, 2019, and testing was started from Aug. 10, 2019 and completed on Aug. 21, 2019. We, SPORTON INTERNATIONAL INC. EMC & Wireless Communications Laboratory, would like to declare that the tested sample has been evaluated in accordance with the procedures given in ANSI C63.10-2013 and shown compliance with the applicable technical standards.

The report must not be used by the client to claim product certification, approval, or endorsement by TAF or any agency of government.

The test results in this report apply exclusively to the tested model / sample. Without written approval of SPORTON INTERNATIONAL INC. EMC & Wireless Communications Laboratory, the test report shall not be reproduced except in full.



Approved by: Allen Lin

SPORTON INTERNATIONAL INC. EMC & Wireless Communications Laboratory

No. 52, Huaya 1st Rd., Guishan Dist., Taoyuan City, Taiwan (R.O.C.)



Table of Contents

- 1 GENERAL DESCRIPTION5**
- 1.1 Information.....5
- 1.2 Testing Applied Standards7
- 1.3 Testing Location Information7
- 1.4 Measurement Uncertainty7
- 2 TEST CONFIGURATION OF EUT.....8**
- 2.1 Test Condition8
- 2.2 The Worst Case Configuration8
- 2.3 The Worst Charger Frequencies Configuration8
- 2.4 The Worst Case Measurement Configuration9
- 2.5 Accessories9
- 2.6 Support Equipment.....9
- 2.7 Test Setup Diagram10
- 3 TRANSMITTER TEST RESULT11**
- 3.1 AC Power-line Conducted Emissions11
- 3.2 Transmitter Radiated Emissions15
- 3.3 Emission Bandwidth23
- 4 TEST EQUIPMENT AND CALIBRATION DATA.....25**

APPENDIX A. TEST PHOTOS

PHOTOGRAPHS OF EUT v01



History of this test report

Report No.	Version	Description	Issued Date
FR980128AW	01	Initial issue of report	Dec. 03, 2019
FR980128AW	02	Revised accessories information (This report is the latest version replacing for the report issued on Dec. 03, 2019.)	Dec. 04, 2019



Summary of Test Result

Report Clause	Ref Std. Clause	Test Items	Result (PASS/FAIL)	Remark
1.1.2	15.203	Antenna Requirement	PASS	-
3.1	15.207	AC Power-line Conducted Emissions	PASS	-
3.2	15.209	Transmitter Radiated Emissions	PASS	-
3.3	15.215(c)	Emission Bandwidth	PASS	-

Declaration of Conformity:
The test results with all measurement uncertainty excluded are presented in accordance with the regulation limits or requirements declared by manufacturers.
Comments and Explanations:
None.

Reviewed by: Sam Tsai

Report Producer: Michelle Tsai



1 General Description

1.1 Information

1.1.1 General Information

Wireless Power Transfer General Information			
Frequency Range	Modulation Mode	Charging Freq. (kHz)	Field Strength (dBuV/m)
130-148 kHz	ASK	140.31	67.65
Power Transfer Method	Output power from each primary coil	That may have multiple primary coils	Charging Method
Magnetic induction and only single primary coil	<15W	No	Client directly contact

Note 1: Field strength performed peak level at 3m.

1.1.2 Antenna Information

Antenna Category	
<input type="checkbox"/>	Equipment placed on the market without antennas
<input checked="" type="checkbox"/>	Integral antenna (antenna permanently attached)
<input type="checkbox"/>	Temporary RF connector provided
<input checked="" type="checkbox"/>	No temporary RF connector provided Transmit chains bypass antenna and soldered temporary RF connector provided for connected measurement. In case of conducted measurements the transmitter shall be connected to the measuring equipment via a suitable attenuator and correct for all losses in the RF path.
<input type="checkbox"/>	External antenna (dedicated antennas)

Antenna General Information		
No.	Ant. Cat.	Ant. Type
1	Integral	Wireless charging antenna coils



1.1.3 EUT Information

Operational Condition	
EUT Power Type	From AC Adapter
Type of EUT	
<input checked="" type="checkbox"/>	Stand-alone
<input type="checkbox"/>	Combined (EUT where the radio part is fully integrated within another device) Combined Equipment - Brand Name / Model No.:
<input type="checkbox"/>	Plug-in radio (EUT intended for a variety of host systems) Host System - Brand Name / Model No.:
<input type="checkbox"/>	Other: The EUT place with the platform.

1.1.4 Test Signal Duty Cycle

Operated Mode for Worst Duty Cycle	
<input type="checkbox"/>	Operated normally mode for worst duty cycle
<input checked="" type="checkbox"/>	Operated test mode for worst duty cycle
Test Signal Duty Cycle (x)	
<input checked="" type="checkbox"/>	100%

1.2 Testing Applied Standards

According to the specifications of the manufacturer, the EUT must comply with the requirements of the following standards:

- ◆ 47 CFR FCC Part 15
- ◆ ANSI C63.10-2013
- ◆ KDB 680106 D01 RF Exposure Wireless Charging Apps v03

1.3 Testing Location Information

Testing Location			
<input checked="" type="checkbox"/>	HWA YA	ADD : No. 52, Huaya 1st Rd., Guishan Dist., Taoyuan City, Taiwan (R.O.C.)	
		TEL : 886-3-327-3456	FAX : 886-3-327-0973
Test site Designation No. TW1190 with FCC.			

Test Condition	Test Site No.	Test Engineer	Test Environment	Test Date
RF Conducted	TH06-HY	Gary	23.7~24.3°C/61~63%	12/Aug/2019
AC Conduction	CO04-HY	Jeff	23.1~25.4°C/63.5~67.9%	21/Aug/2019
Radiated Emission	03CH03-HY	Justin	19.2~24.3°C/49.6~51.8%	10/Aug/2019

1.4 Measurement Uncertainty

ISO/IEC 17025 requires that an estimate of the measurement uncertainties associated with the emissions test results be included in the report. The measurement uncertainties given below are based on a 95% confidence level (based on a coverage factor (k=2))

Measurement Uncertainty			
Test Item		Uncertainty	Limit
Radio Frequency		$\pm 6.7 \times 10^{-8}$	$\pm 1 \times 10^{-7}$
All emissions, radiated	9 – 150 kHz	± 1.6 dB	± 6 dB
	0.15 – 30 MHz	± 1.6 dB	± 6 dB
	30 – 1000 MHz	± 2.6 dB	± 6 dB
Temperature		± 0.8 °C	± 1 °C
Humidity		± 5 %	± 5 %
DC and low frequency voltages		± 0.9 %	± 3 %



2 Test Configuration of EUT

2.1 Test Condition

Condition Item	Abbreviation/Remark	Remark
Tnom Vnom	Tnom	20°C
-	Vnom	120V

2.2 The Worst Case Configuration

Modulation Mode	Field Strength (dBuV/m at 3m)
ASK	67.65

Wireless charger were performed all charging conditions including variable loading and non-charging operation, the worst mode is full charging loading.

2.3 The Worst Charger Frequencies Configuration

Modulation Mode	Charger Frequencies (kHz)
ASK	140.31

Wireless charger frequencies are variable frequency range (130-148 kHz) and depend on charging loading.

2.4 The Worst Case Measurement Configuration

The Worst Case Mode for Following Conformance Tests	
Tests Item	AC power-line conducted emissions
Condition	AC power-line conducted measurement for line and neutral
Operating Mode	<input checked="" type="checkbox"/> 1. Adapter Mode

The Worst Case Mode for Following Conformance Tests	
Tests Item	Transmitter Radiated Emissions, Emission Bandwidth
Test Condition	Radiated measurement
User Position	<input type="checkbox"/> EUT will be placed in fixed position.
	<input checked="" type="checkbox"/> EUT will be placed in mobile position and operating multiple positions.
	<input type="checkbox"/> EUT will be a hand-held or body-worn battery-powered devices and operating multiple positions.
Operating Mode	<input checked="" type="checkbox"/> 1. Adapter Mode
Orthogonal Planes of EUT	Y Plane
	

2.5 Accessories

Accessories Information		
Type-C cable	Signal Line	1.2 meter, shielded cable, w/o ferrite core

Reminder: Regarding to more detail and other information, please refer to user manual.

2.6 Support Equipment

Support Equipment - AC Conduction/Conducted/Radiated				
No.	Equipment	Brand Name	Model Name	FCC ID
1	Phone	DATALOGIC	Memor20	-
2	AC Adapter	CHAnnEL WELL	2ACP0183	-

Note: Support equipment No.2 was provided by customer.

2.7 Test Setup Diagram

Test Setup Diagram – AC Line Conducted Emission Test

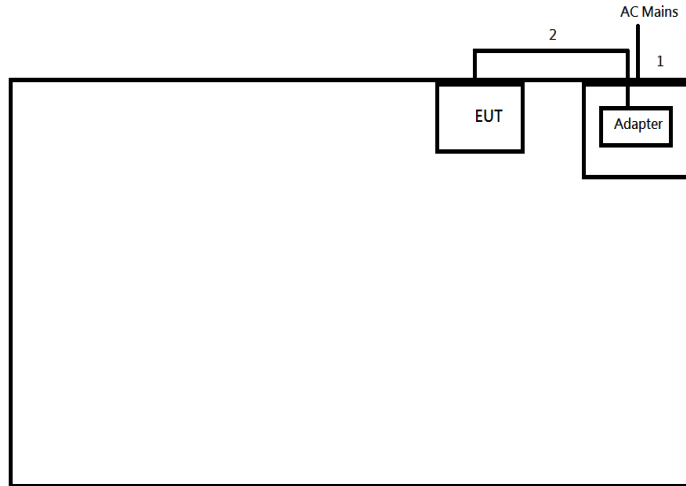

Item	Connection	Shielded	Length(m)	Remark
1	Power Cable	No	1.8	-
2	Type-C Cable	No	1.0	-

Test Setup Diagram - Radiated Test

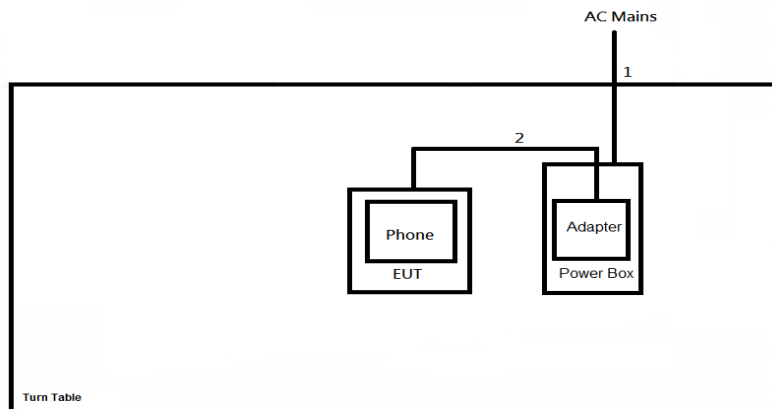

Item	Connection	Shielded	Length(m)	Remark
1	Power Cable	No	1.8	-
2	Type-C Cable	No	1.0	-



3 Transmitter Test Result

3.1 AC Power-line Conducted Emissions

3.1.1 AC Power-line Conducted Emissions Limit

AC Power-line Conducted Emissions Limit		
Frequency Emission (MHz)	Quasi-Peak	Average
0.15-0.5	66 - 56 *	56 - 46 *
0.5-5	56	46
5-30	60	50

Note 1: * Decreases with the logarithm of the frequency.

3.1.2 Measuring Instruments

Refer a test equipment and calibration data table in this test report.

3.1.3 Test Procedures

Test Method	
<input checked="" type="checkbox"/>	Refer as ANSI C63.10-2013, clause 6.2 for AC power-line conducted emissions.
<input checked="" type="checkbox"/>	If AC conducted emissions fall in operating band, then following below test method confirm final result.
<input type="checkbox"/>	Accept measurements done with a suitable dummy load replacing the antenna under the following conditions: (1) Perform the AC line conducted tests with the antenna connected to determine compliance with FCC 15.207 limits outside the transmitter's fundamental emission band; (2) Retest with a dummy load to determine compliance with FCC 15.207 limits within the transmitter's fundamental emission band.
<input checked="" type="checkbox"/>	For a device with a permanent antenna operating at or below 30 MHz, accept measurements done with a suitable dummy load, in lieu of the permanent antenna under the following conditions: (1) Perform the AC line conducted tests with the permanent antenna to determine compliance with the FCC 15.207 limits outside the transmitter's fundamental emission band; (2) Retest with a dummy load in lieu of the permanent antenna to determine compliance with the FCC 15.207 limits within the transmitter's fundamental emission band.

3.1.4 Test Setup

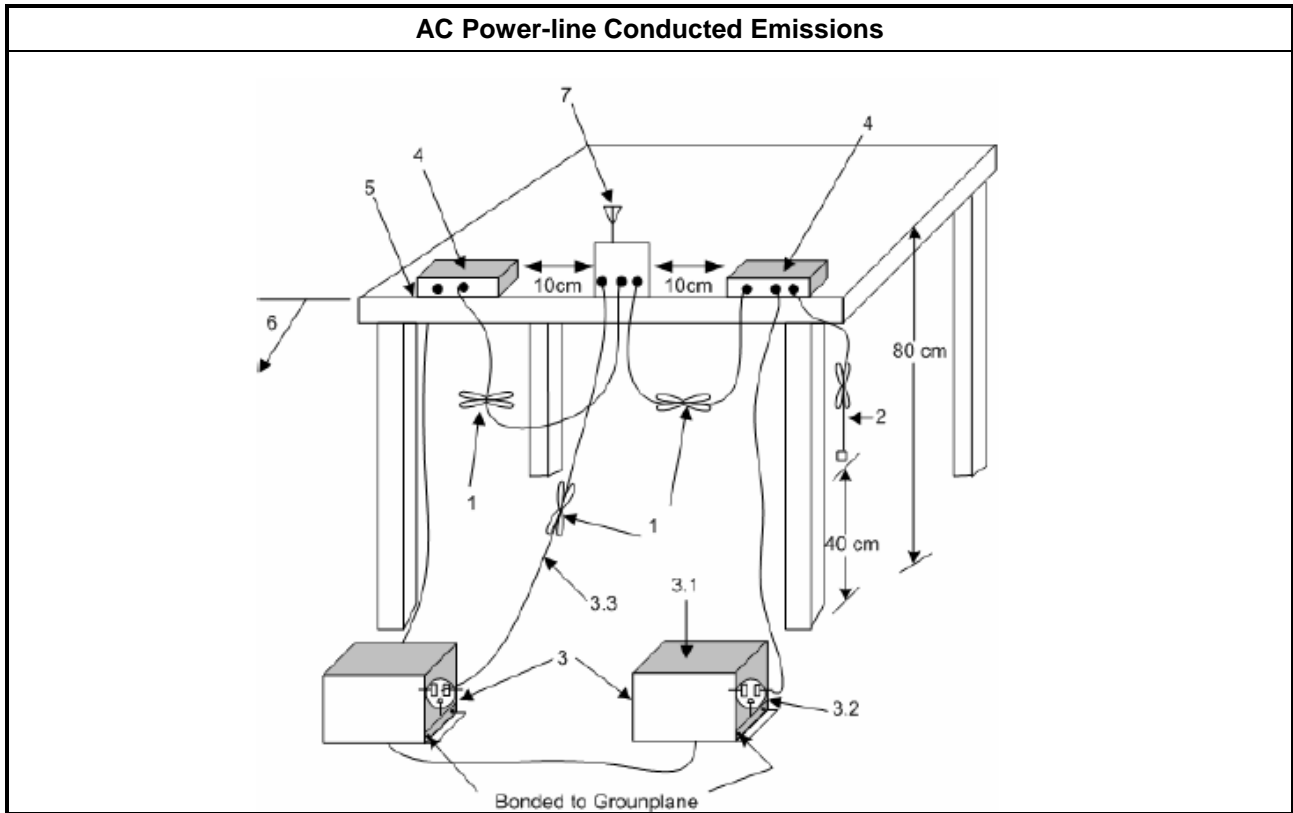

3.1.5 Test Result of AC Power-line Conducted Emissions

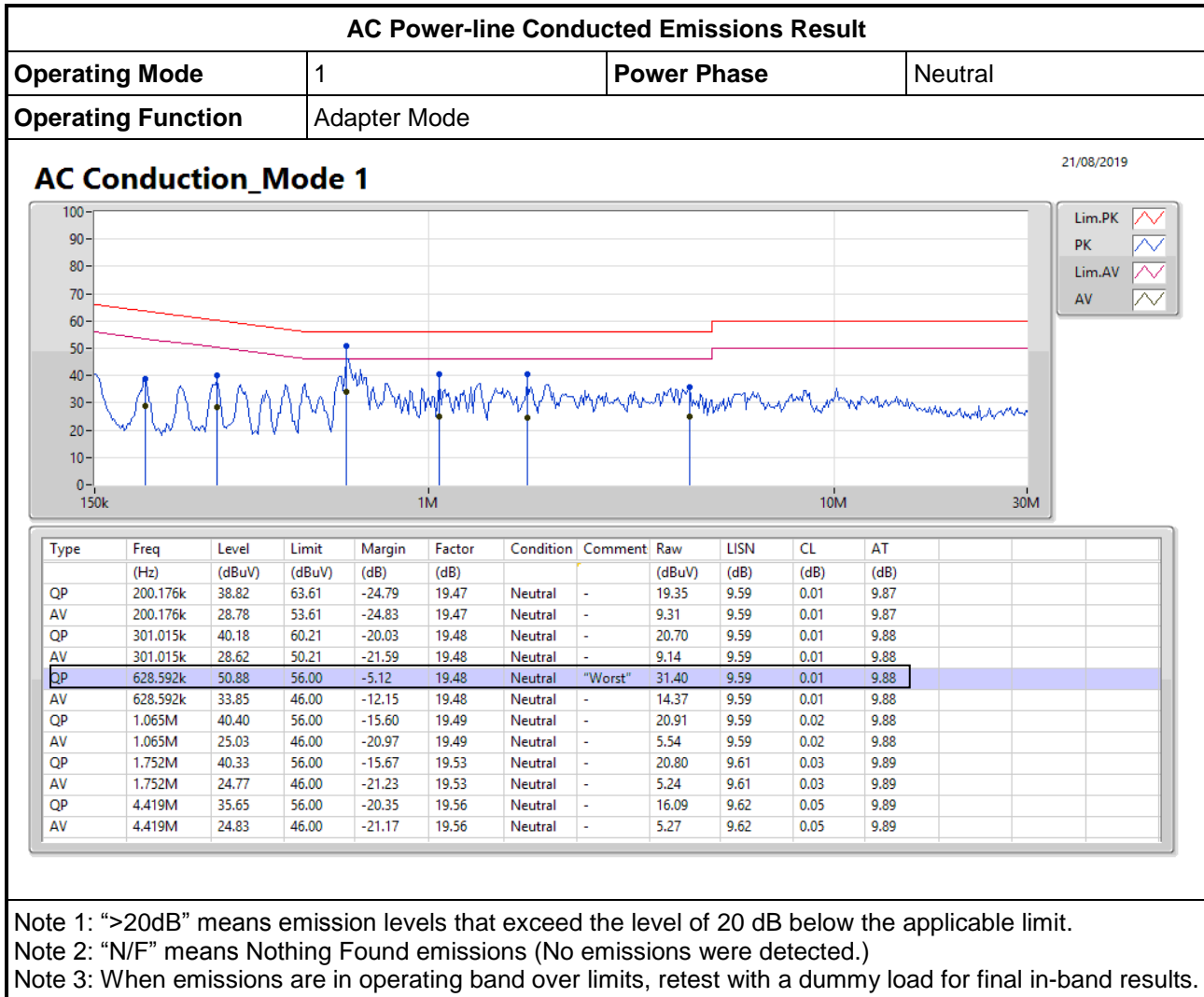



AC Power-line Conducted Emissions Result

Operating Mode	1	Power Phase	Line
Operating Function	Adapter Mode		

AC Conduction_Mode 1

21/08/2019

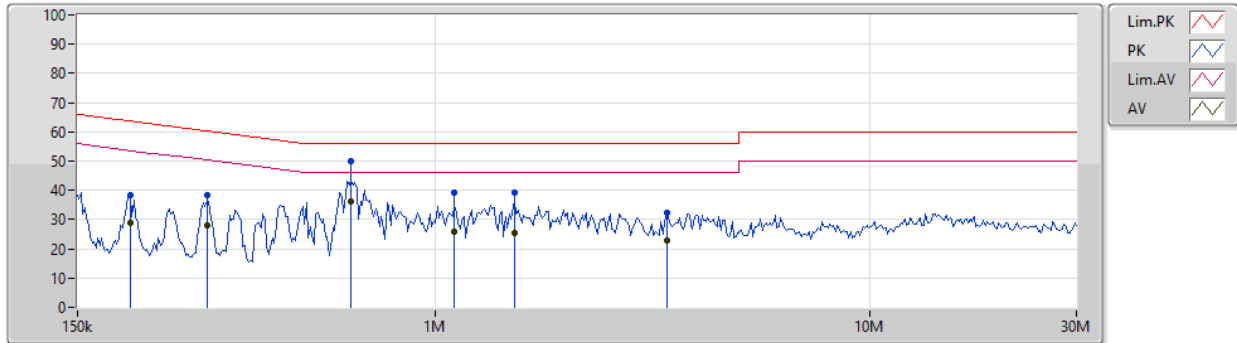

Type	Freq (Hz)	Level (dBuV)	Limit (dBuV)	Margin (dB)	Factor (dB)	Condition	Comment	Raw (dBuV)	LISN (dB)	CL (dB)	AT (dB)
QP	198.194k	38.53	63.69	-25.16	19.48	Line	-	19.05	9.60	0.01	9.87
AV	198.194k	28.84	53.69	-24.85	19.48	Line	-	9.36	9.60	0.01	9.87
QP	298.034k	38.52	60.30	-21.78	19.48	Line	-	19.04	9.59	0.01	9.88
AV	298.034k	28.16	50.30	-22.14	19.48	Line	-	8.68	9.59	0.01	9.88
QP	641.227k	49.92	56.00	-6.08	19.49	Line	"Worst"	30.43	9.60	0.01	9.88
AV	641.227k	36.11	46.00	-9.89	19.49	Line	-	16.62	9.60	0.01	9.88
QP	1.108M	39.05	56.00	-16.95	19.50	Line	-	19.55	9.60	0.02	9.88
AV	1.108M	25.94	46.00	-20.06	19.50	Line	-	6.44	9.60	0.02	9.88
QP	1.524M	39.19	56.00	-16.81	19.53	Line	-	19.66	9.61	0.03	9.89
AV	1.524M	25.55	46.00	-20.45	19.53	Line	-	6.02	9.61	0.03	9.89
QP	3.412M	32.53	56.00	-23.47	19.56	Line	-	12.97	9.63	0.04	9.89
AV	3.412M	23.02	46.00	-22.98	19.56	Line	-	3.46	9.63	0.04	9.89

Note 1: ">20dB" means emission levels that exceed the level of 20 dB below the applicable limit.
 Note 2: "N/F" means Nothing Found emissions (No emissions were detected.)
 Note 3: When emissions are in operating band over limits, retest with a dummy load for final in-band results.



3.2 Transmitter Radiated Emissions

3.2.1 Transmitter Radiated Emissions Limit

Transmitter Radiated Emissions Limit			
Frequency Range (MHz)	Field Strength (uV/m)	Field Strength (dBuV/m)	Measure Distance (m)
0.009~0.490	2400/F(kHz)	48.5 - 13.8	300
0.490~1.705	24000/F(kHz)	33.8 - 23	30
1.705~30.0	30	29	30
30~88	100	40	3
88~216	150	43.5	3
216~960	200	46	3
Above 960	500	54	3

Note 1: Test distance for frequencies at or above 30 MHz, measurements may be performed at a distance other than the limit distance provided they are not performed in the near field and the emissions to be measured can be detected by the measurement equipment. When performing measurements at a distance other than that specified, the results shall be extrapolated to the specified distance using an extrapolation factor of 20 dB/decade (inverse of linear distance for field-strength measurements, inverse of linear distance-squared for power-density measurements).

Note 2: Test distance for frequencies at below 30 MHz, measurements may be performed at a distance closer than the EUT limit distance; however, an attempt should be made to avoid making measurements in the near field. When performing measurements below 30 MHz at a closer distance than the limit distance, the results shall be extrapolated to the specified distance by either making measurements at a minimum of two or more distances on at least one radial to determine the proper extrapolation factor or by using the square of an inverse linear distance extrapolation factor (40 dB/decade). The test report shall specify the extrapolation method used to determine compliance of the EUT.

Note 3: the frequency bands 9-90 kHz, 110-490 kHz measurements employing an average detector and other below 1GHz measurements employing a CISPR quasi-peak detector.

3.2.2 Measuring Instruments

Refer a test equipment and calibration data table in this test report.



3.2.3 Test Procedures

Test Method	
<input checked="" type="checkbox"/>	Refer as ANSI C63.10, clause 6.5 for radiated emissions from 30 MHz to 1 GHz and test distance is 3m.
<input checked="" type="checkbox"/>	Refer as ANSI C63.10, clause 6.4 for radiated emissions from below 30 MHz the frequency bands 9-90 kHz, 110-490 kHz measurements employing an average detector and other below 30MHz measurements employing a CISPR quasi-peak detector. Test distance is 3m.
<input checked="" type="checkbox"/>	At frequencies below 30 MHz, measurements may be performed at a distance closer than that specified in the requirements; however, an attempt should be made to avoid making measurements in the near field. Pending the development of an appropriate measurement procedure for measurements performed below 30 MHz, when performing measurements at a closer distance than specified, the results shall be following below methods.
<input type="checkbox"/>	The results shall be extrapolated to the specified distance by making measurements at a minimum of two distances on at least one radial to determine the proper extrapolation factor.
<input checked="" type="checkbox"/>	The results shall be by using the square of an inverse linear distance extrapolation factor (40 dB/decade).
<input checked="" type="checkbox"/>	For radiated measurement. Loop antenna was rotated about the horizontal and vertical axis and the equipment to be measured and the test antenna shall be oriented to obtain the maximum emitted field strength level.
<input checked="" type="checkbox"/>	The any unwanted emissions level shall not exceed the fundamental emission level.
<input checked="" type="checkbox"/>	All amplitude of spurious emissions that are attenuated by more than 20 dB below the permissible value has no need to be reported.

3.2.4 Test Setup

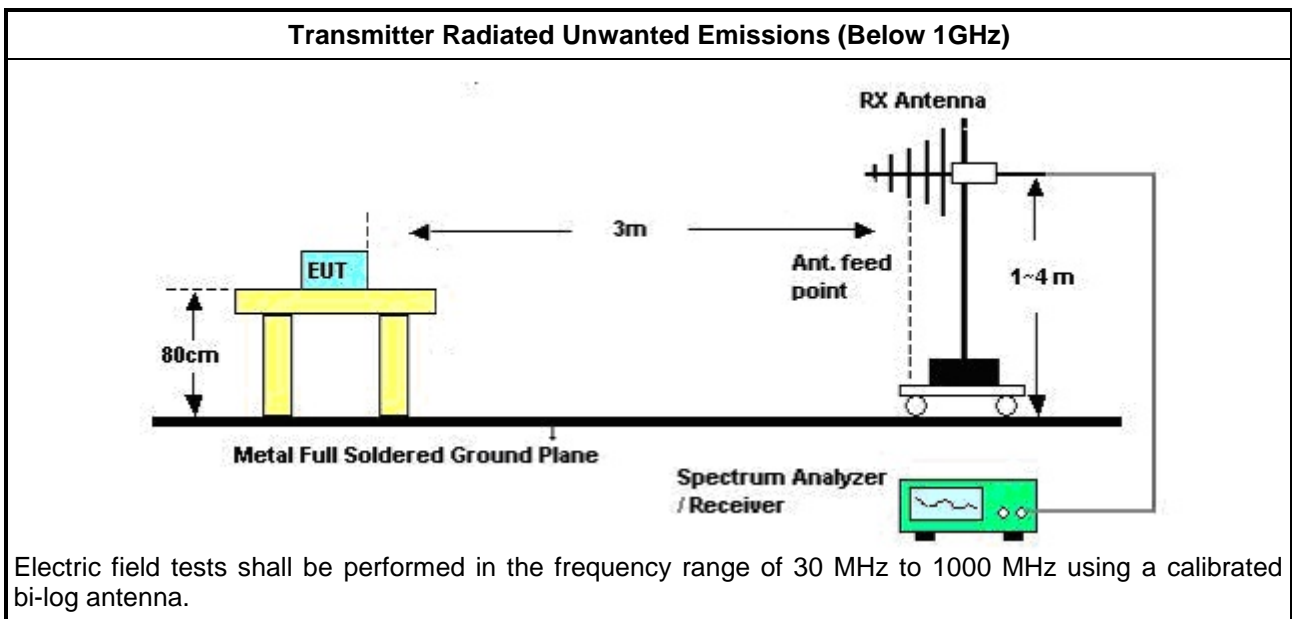
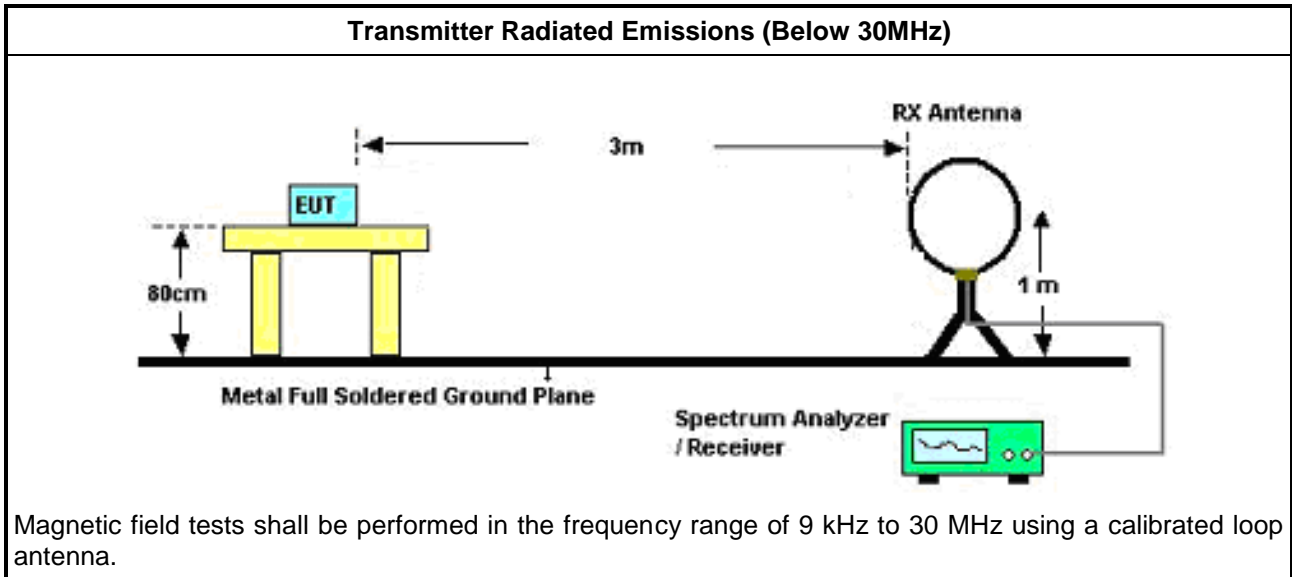



3.2.5 Transmitter Radiated Emissions (Below 30MHz)

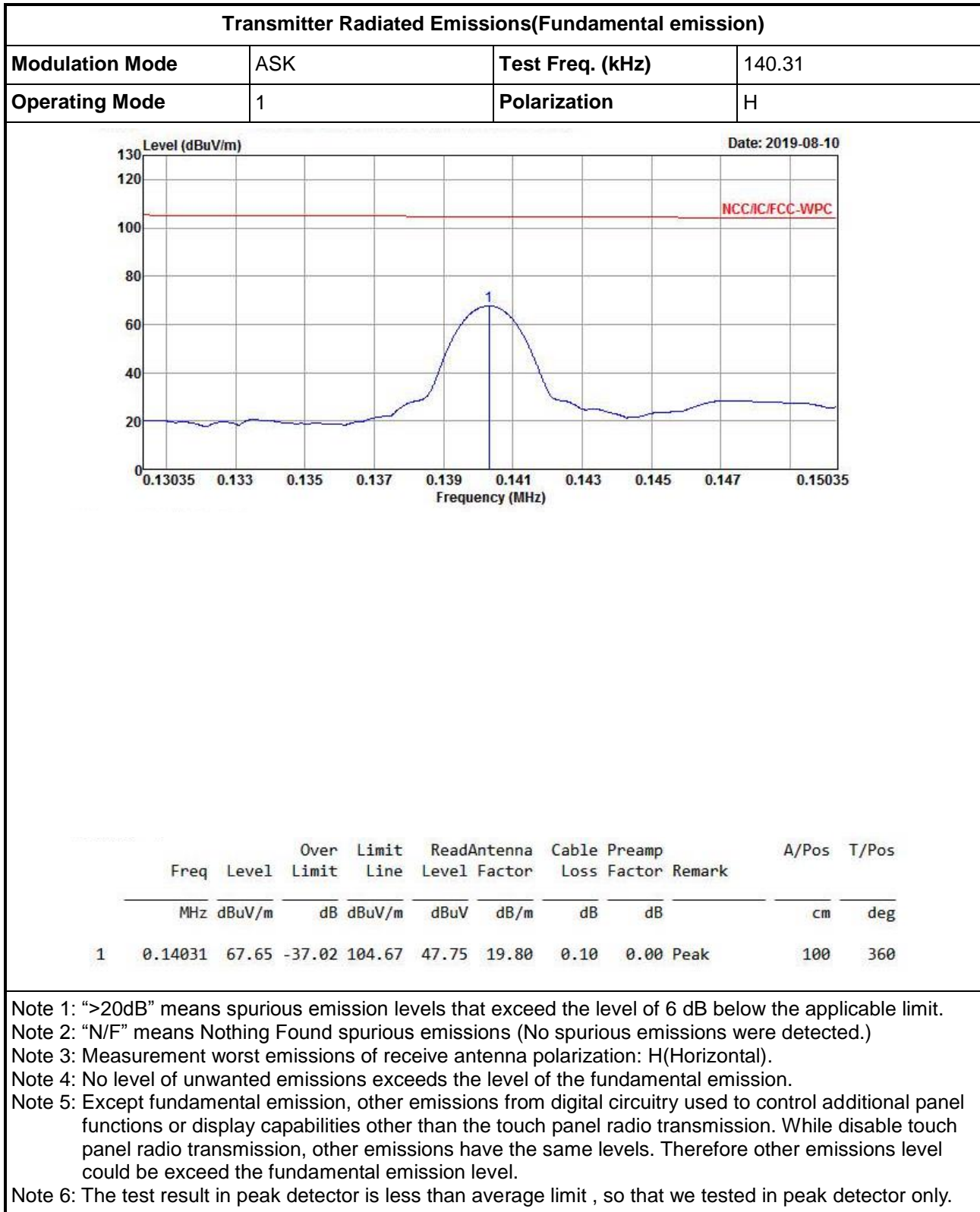



Transmitter Radiated Emissions (9 kHz – 150 kHz)

Modulation Mode	ASK	Test Freq. (kHz)	140.31
Operating Mode	1	Polarization	H

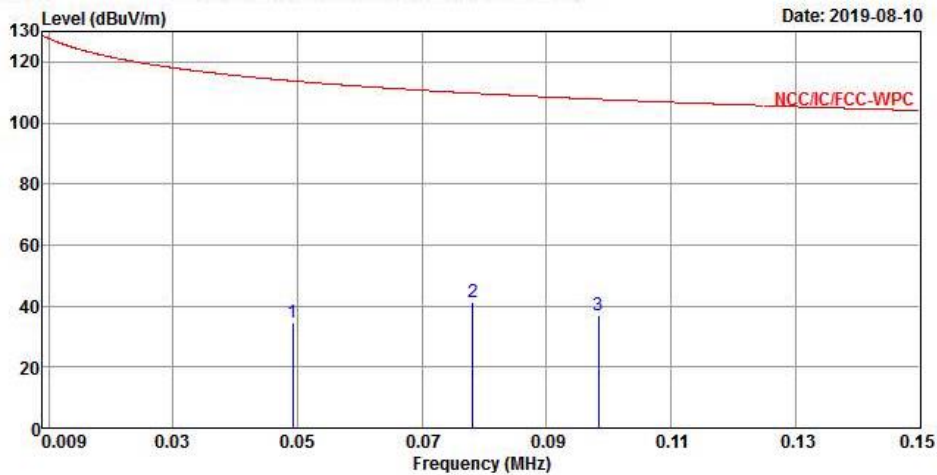

	Freq	Level	Over Limit	Limit Line	ReadAntenna Level	Antenna Factor	Cable Loss	Preamp Factor	Remark	A/P
	MHz	dBuV/m	dB	dBuV/m	dBuV	dB/m	dB	dB		
1	0.04919	34.73	-79.04	113.77	14.17	20.49	0.07	0.00	Peak	1
2	0.07809	41.08	-68.68	109.76	20.94	20.05	0.09	0.00	Peak	1
3	0.09839	37.07	-70.68	107.75	17.24	19.73	0.10	0.00	Peak	1

Note 1: ">20dB" means spurious emission levels that exceed the level of 6 dB below the applicable limit.
 Note 2: "N/F" means Nothing Found spurious emissions (No spurious emissions were detected.)
 Note 3: Measurement worst emissions of receive antenna polarization: H(Horizontal).
 Note 4: No level of unwanted emissions exceeds the level of the fundamental emission.
 Note 5: Except fundamental emission, other emissions from digital circuitry used to control additional panel functions or display capabilities other than the touch panel radio transmission. While disable touch panel radio transmission, other emissions have the same levels. Therefore other emissions level could be exceed the fundamental emission level.



Transmitter Radiated Emissions (150 kHz – 30 MHz)

Modulation Mode	ASK	Test Freq. (kHz)	140.31
Operating Mode	1	Polarization	H

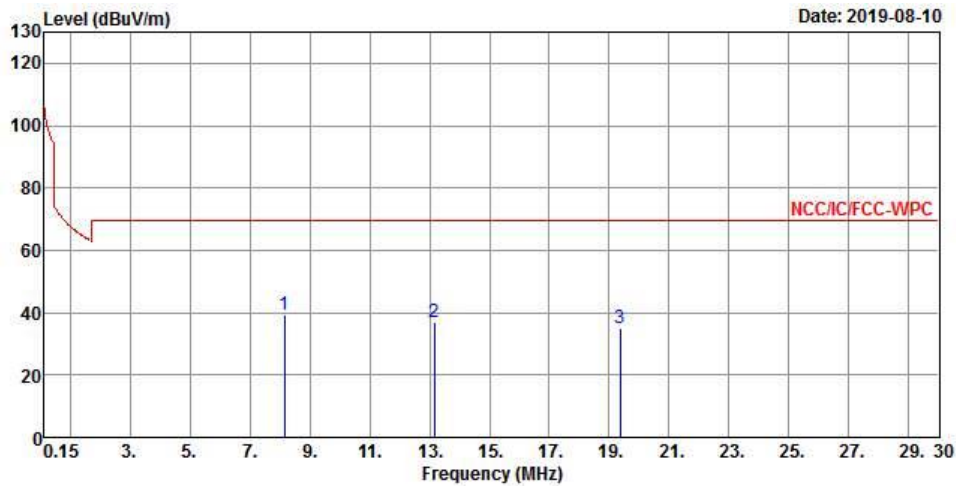

	Freq	Level	Over Limit	Limit Line	ReadAntenna Level	Antenna Factor	Cable Loss	Preamp Factor	Remark	A/Pos	T/Pos
	MHz	dBuV/m	dB	dBuV/m	dBuV	dB/m	dB	dB		cm	deg
1	8.14980	39.50	-30.04	69.54	17.70	21.41	0.39	0.00	Peak	100	360
2	13.16460	37.15	-32.39	69.54	14.46	22.16	0.53	0.00	Peak	100	360
3	19.37340	35.06	-34.48	69.54	11.95	22.47	0.64	0.00	Peak	100	360

Note 1: ">20dB" means spurious emission levels that exceed the level of 6 dB below the applicable limit.
 Note 2: "N/F" means Nothing Found spurious emissions (No spurious emissions were detected.)
 Note 3: Measurement worst emissions of receive antenna polarization: H(Horizontal).
 Note 4: No level of unwanted emissions exceeds the level of the fundamental emission.
 Note 5: Except fundamental emission, other emissions from digital circuitry used to control additional panel functions or display capabilities other than the touch panel radio transmission. While disable touch panel radio transmission, other emissions have the same levels. Therefore other emissions level could be exceed the fundamental emission level.



3.2.6 Transmitter Radiated Emissions (Above 30MHz)

Transmitter Radiated Emissions (Above 30MHz)			
Modulation Mode	ASK	Test Freq. (kHz)	140.31
Operating Mode	1	Polarization	V

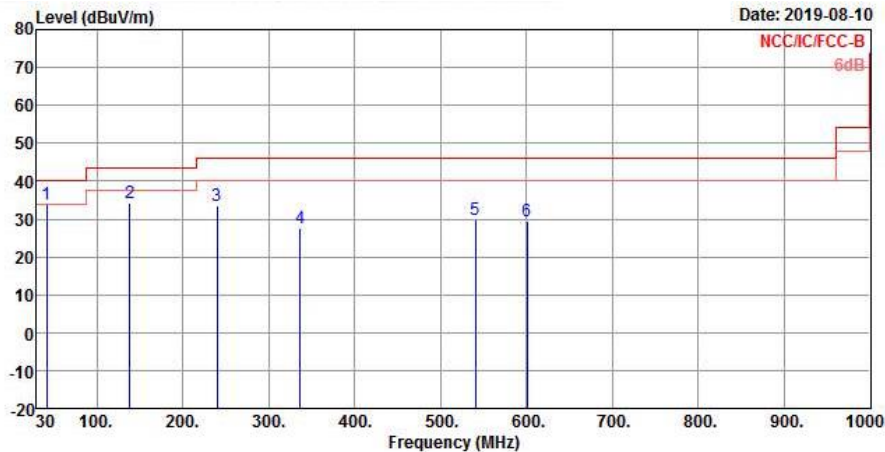

	Freq	Level	Over Limit	Limit Line	ReadAntenna Level	Antenna Factor	Cable Loss	Preamp Factor	Remark	A/Pos	T/Pos
	MHz	dBuV/m	dB	dBuV/m	dBuV	dB/m	dB	dB		cm	deg
1	41.64000	33.90	-6.10	40.00	43.76	16.72	0.95	27.53	Peak	100	0
2	138.64000	34.20	-9.30	43.50	43.32	16.31	1.81	27.24	Peak	100	0
3	239.52000	33.40	-12.60	46.00	41.40	16.36	2.42	26.78	Peak	100	0
4	336.52000	27.62	-18.38	46.00	32.73	18.88	2.91	26.90	Peak	100	0
5	540.22000	29.70	-16.30	46.00	30.43	23.54	3.74	28.01	Peak	100	0
6	600.36000	29.32	-16.68	46.00	29.54	23.75	4.08	28.05	Peak	100	0

Note 1: ">20dB" means spurious emission levels that exceed the level of 6 dB below the applicable limit.
 Note 2: "N/F" means Nothing Found spurious emissions (No spurious emissions were detected.)
 Note 3: Measurement receive antenna polarization: H (Horizontal), V (Vertical)
 Note 4: No level of unwanted emissions exceeds the level of the fundamental emission.
 Note 5: Except fundamental emission, other emissions from digital circuitry used to control additional panel functions or display capabilities other than the touch panel radio transmission. While disable touch panel radio transmission, other emissions have the same levels. Therefore other emissions level could be exceed the fundamental emission level.



Transmitter Radiated Emissions (Above 30MHz)			
Modulation Mode	ASK	Test Freq. (kHz)	140.31
Operating Mode	1	Polarization	H

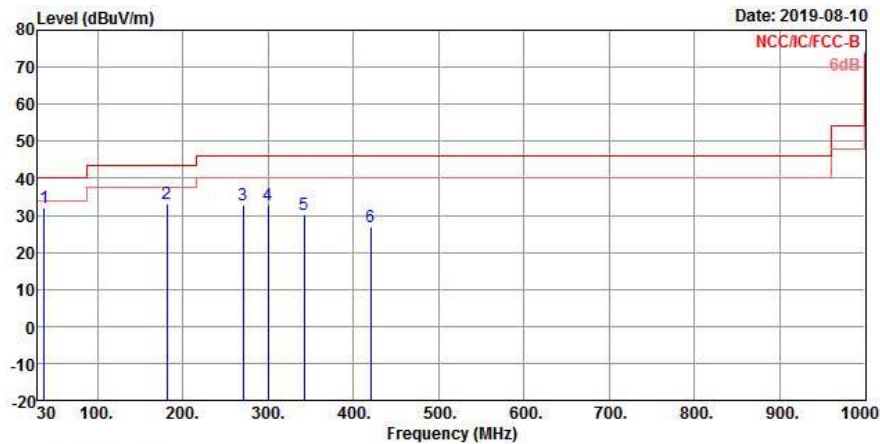

	Freq	Level	Over Limit	Limit Line	ReadAntenna Level	Antenna Factor	Cable Loss	Preamp Factor	Remark	A/Pos	T/Pos
	MHz	dBuV/m	dB	dBuV/m	dBuV	dB/m	dB	dB		cm	deg
1	37.76000	32.05	-7.95	40.00	40.02	18.67	0.91	27.55	Peak	100	360
2	181.32000	33.12	-10.38	43.50	43.74	14.30	2.11	27.03	Peak	100	360
3	270.56000	32.68	-13.32	46.00	38.82	17.99	2.59	26.72	Peak	100	360
4	299.66000	32.90	-13.10	46.00	38.59	18.26	2.75	26.70	Peak	100	360
5	342.34000	30.28	-15.72	46.00	35.21	19.07	2.94	26.94	Peak	100	360
6	419.94000	27.03	-18.97	46.00	29.31	21.91	3.26	27.45	Peak	100	360

Note 1: ">20dB" means spurious emission levels that exceed the level of 6 dB below the applicable limit.
 Note 2: "N/F" means Nothing Found spurious emissions (No spurious emissions were detected.)
 Note 3: Measurement receive antenna polarization: H (Horizontal), V (Vertical)
 Note 4: No level of unwanted emissions exceeds the level of the fundamental emission.
 Note 5: Except fundamental emission, other emissions from digital circuitry used to control additional panel functions or display capabilities other than the touch panel radio transmission. While disable touch panel radio transmission, other emissions have the same levels. Therefore other emissions level could be exceed the fundamental emission level.

3.3 Emission Bandwidth

3.3.1 Emission Bandwidth Limit

Emission Bandwidth Limit
N/A

3.3.2 Measuring Instruments

Refer a test equipment and calibration data table in this test report.

3.3.3 Test Procedures

Test Method
<input checked="" type="checkbox"/> For the emission bandwidth refer ANSI C63.10, clause 6.9.3 for occupied bandwidth testing.
<input checked="" type="checkbox"/> For radiated measurement. Loop antenna was rotated about the horizontal and vertical axis and the equipment to be measured and the test antenna shall be oriented to obtain the maximum emitted field strength level.

3.3.4 Test Setup

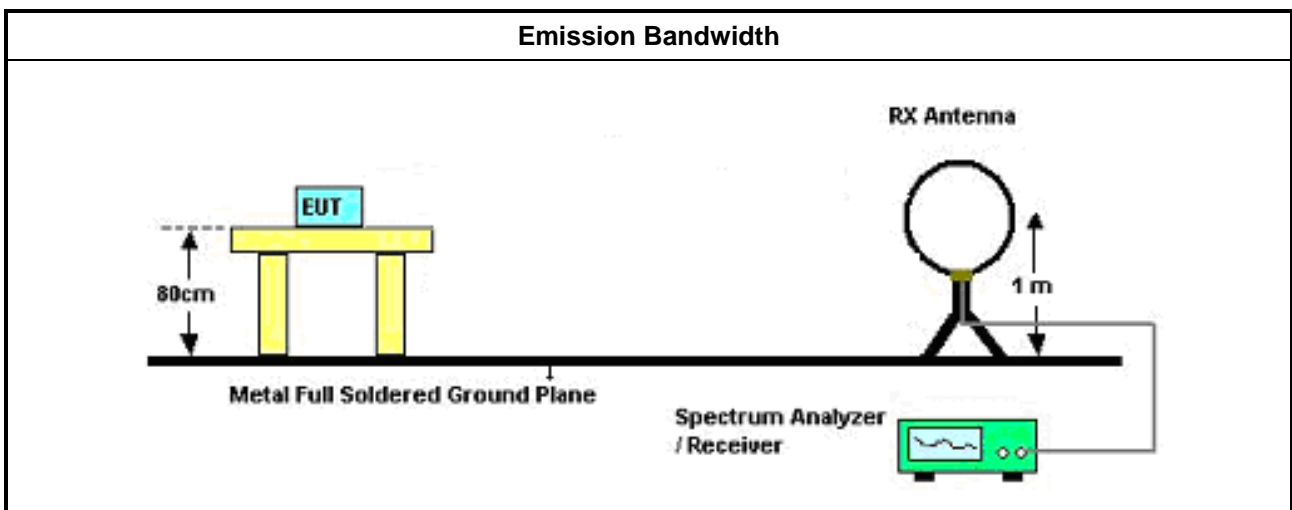

3.3.5 Test Result of Emission Bandwidth

Occupied Channel Bandwidth Result			
Modulation Mode	Frequency (kHz)	20dB Bandwidth (kHz)	99% Bandwidth (kHz)
ASK	140.31	2.46	2.11
Limit		N/A	N/A
Result		Complied	

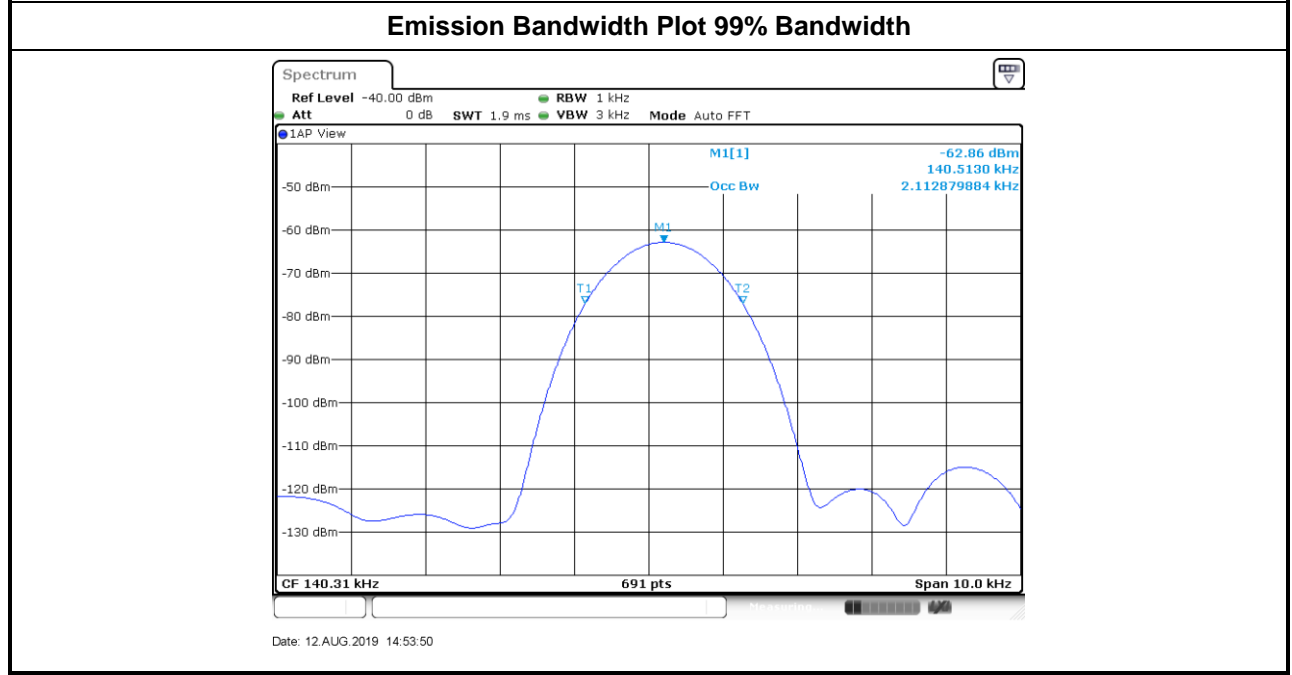
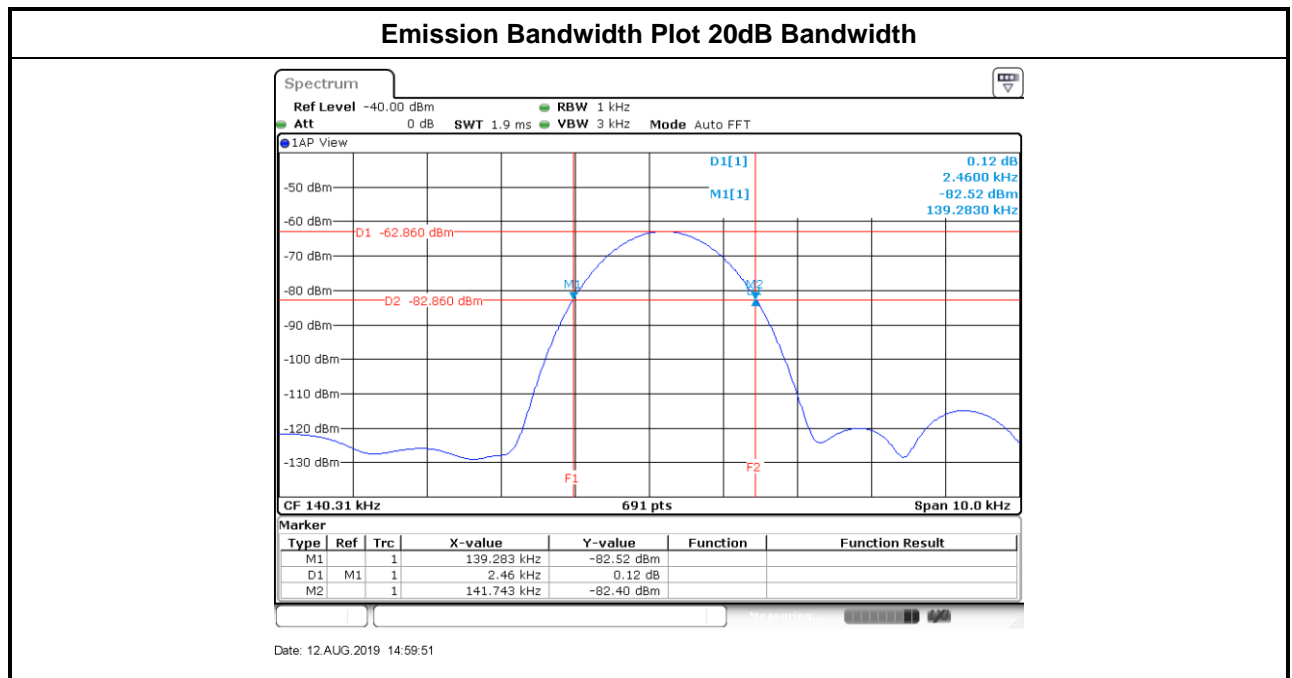



4 Test Equipment and Calibration Data

Instrument for AC Conduction

Instrument	Manufacturer	Model No.	Serial No.	Spec.	Calibration Date	Calibration Due Date
EMC Receiver	R&S	ESR3	102052	9kHz ~ 3.6GHz	09/Apr/2019	08/Apr/2020
LISN	R&S	ENV216	101295	9kHz ~ 30MHz	08/Nov/2018	07/Nov/2019
RF Cable-CON	MTJ	RG142	CB002-CO	9kHz ~ 200MHz	17/Sep/2018	16/Sep/2019
AC POWER	APC	AFC-11005G	F310050055	47Hz~63Hz 5~300V	NCR	NCR
Impuls Begrenzer Pulse Limiter	SCHWARZBECK	VTSD 9561-F	9561-F041	9 kHz ~ 30 MHz	12/Oct/2018	11/Oct/2019

NCR : Non-Calibration Require

Instrument for Conducted Test

Instrument	Manufacturer	Model No.	Serial No.	Spec.	Calibration Date	Calibration Due Date
Spectrum Analyzer	R&S	FSV 40	101013	9kHz~40GHz	13/Mar/2019	12/Mar/2020
Loop Antenna	TESEQ	HLA 6120	31244	9kHz ~ 30MHz	15/Mar/2019	14/Mar/2020

Instrument for Radiated Test

Instrument	Manufacturer	Model No.	Serial No.	Spec.	Calibration Date	Calibration Due Date
3m Semi Anechoic Chamber	SIDT FRANKONIA	SAC-3M	03CH03-HY	30MHz ~ 1GHz 3m	30/Oct/2018	29/Oct/2019
3m Semi Anechoic Chamber	SIDT FRANKONIA	SAC-3M	03CH03-HY	1GHz ~ 18GHz 3m	30/Oct/2018	29/Oct/2019
Amplifier	IFI	SCCX150	03CH03-HY	10KHz ~ 100MHz	14/Sep/2017	13/Sep/2019
Amplifier	HP	8447D	2944A08033	10kHz ~ 1.3GHz	22/Apr/2019	21/Apr/2020
EMI Test Receiver	R&S	ESR3	102052	9kHz ~ 3.6GHz	09/Apr/2019	08/Apr/2020
Bilog Antenna with 5dB Pad	ETS	3142B & MTJ6102-05	00022055	26 MHz - 3 GHz	19/Nov/2018	18/Nov/2019
Signal Analyzer	R&S	FSV40	101013	10Hz ~ 40GHz	13/Mar/2019	12/Mar/2020
RF Cable-R03m	Jye Bao	RG142	CB021	9kHz ~ 1GHz	22/Mar/2019	21/Mar/2020
Loop Antenna	TESEQ	HLA 6120	31244	9kHz ~ 30MHz	15/Mar/2019	14/Mar/2020