

# FCC Test Report

**FCC ID** : U4G-Q104G  
**Equipment** : PDA  
**Brand Name** : DATALOGIC  
**Model Name** : MEMOR 20 WWAN  
**Applicant** : Datalogic S.r.l.  
Via S. Vitalino, 13 40012, Lippo di  
Calderara di Reno (BO) ITALY  
**Manufacturer** : Datalogic S.r.l.  
Via S. Vitalino, 13 40012, Lippo di  
Calderara di Reno (BO) ITALY  
**Standard** : 47 CFR FCC Part 15.407

The product was received on Sep. 20, 2018, and testing was started from Aug. 13, 2019 and completed on Sep. 11, 2019. We, SPORTON INTERNATIONAL INC. EMC & Wireless Communications Laboratory, would like to declare that the tested sample has been evaluated in accordance with the procedures given in ANSI C63.10-2013 and shown compliance with the applicable technical standards.

The report must not be used by the client to claim product certification, approval, or endorsement by TAF or any agency of government.

The test results in this report apply exclusively to the tested model / sample. Without written approval of SPORTON INTERNATIONAL INC. EMC & Wireless Communications Laboratory, the test report shall not be reproduced except in full.



Approved by: Allen Lin

**SPORTON INTERNATIONAL INC. EMC & Wireless Communications Laboratory**

No. 52, Huaya 1st Rd., Guishan Dist., Taoyuan City, Taiwan (R.O.C.)



# Table of Contents

**HISTORY OF THIS TEST REPORT .....3**

**SUMMARY OF TEST RESULT .....4**

**1 GENERAL DESCRIPTION .....5**

1.1 Information.....5

1.2 Testing Applied Standards .....8

1.3 Testing Location Information .....8

1.4 Measurement Uncertainty .....8

**2 TEST CONFIGURATION OF EUT.....9**

2.1 Test Condition .....9

2.2 Test Channel Mode .....9

2.3 The Worst Case Measurement Configuration.....11

2.4 Accessories and Support Equipment .....12

2.5 Test Setup Diagram .....13

**3 TRANSMITTER TEST RESULT .....14**

3.1 AC Power-line Conducted Emissions .....14

3.2 Emission Bandwidth .....16

3.3 Maximum Conducted Output Power .....17

3.4 Peak Power Spectral Density.....19

3.5 Unwanted Emissions.....21

**4 TEST EQUIPMENT AND CALIBRATION DATA.....25**

**APPENDIX A. TEST RESULTS OF AC POWER-LINE CONDUCTED EMISSIONS**

**APPENDIX B. TEST RESULTS OF EMISSION BANDWIDTH**

**APPENDIX C. TEST RESULTS OF MAXIMUM CONDUCTED OUTPUT POWER**

**APPENDIX D. TEST RESULTS OF PEAK POWER SPECTRAL DENSITY**

**APPENDIX E. TEST RESULTS OF UNWANTED EMISSIONS**

**APPENDIX F. TEST RESULTS OF RADIATED EMISSION CO-LOCATION**

**APPENDIX G. TEST PHOTOS**

**PRODUCTION POWER TABLE**

**PHOTOGRAPHS OF EUT V01**





### Summary of Test Result

Report Clause	Ref. Std. Clause	Test Items	Result (PASS/FAIL)	Remark
1.1.2	15.203	Antenna Requirement	PASS	-
3.1	15.207	AC Power-line Conducted Emissions	PASS	-
3.2	15.407(a)	Emission Bandwidth	PASS	-
3.3	15.407(a)	Maximum Conducted Output Power	PASS	-
3.4	15.407(a)	Peak Power Spectral Density	PASS	-
3.5	15.407(b)	Unwanted Emissions	PASS	-

<b>Declaration of Conformity:</b>
The test results with all measurement uncertainty excluded are presented in accordance with the regulation limits or requirements declared by manufacturers.
<b>Comments and explanations:</b>
None

Reviewed by: Jackson Tsai

Report Producer: Ann Hou



# 1 General Description

## 1.1 Information

### 1.1.1 RF General Information

Frequency Range (MHz)	IEEE Std. 802.11	Ch. Frequency (MHz)	Channel Number
5150-5250	a, n (HT20), ac (VHT20)	5180-5240	36-48 [4]
5250-5350		5260-5320	52-64 [4]
5470-5725		5500-5700	100-140 [8]
Straddle 5720		5720	144 [1]
5725-5850		5745-5825	149-165 [5]
5150-5250	n (HT40), ac (VHT40)	5190-5230	38-46 [2]
5250-5350		5270-5310	54-62 [2]
5470-5725		5510-5670	102-134 [3]
Straddle 5710		5710	142 [1]
5725-5850		5755-5795	151-159 [2]
5150-5250	ac (VHT80)	5210	42 [1]
5250-5350		5290	58 [1]
5470-5725		5530	106 [1]
Straddle 5690		5690	138 [1]
5725-5850		5775	155 [1]

Band	Mode	BWch (MHz)	Nant
5.15-5.25GHz	802.11a	20	1TX
5.25-5.35GHz	802.11a	20	1TX
5.47-5.725GHz	802.11a	20	1TX
5.725-5.85GHz	802.11a	20	1TX
5.15-5.25GHz	802.11ac VHT20	20	1TX
5.25-5.35GHz	802.11ac VHT20	20	1TX
5.47-5.725GHz	802.11ac VHT20	20	1TX
5.725-5.85GHz	802.11ac VHT20	20	1TX
5.15-5.25GHz	802.11ac VHT40	40	1TX
5.25-5.35GHz	802.11ac VHT40	40	1TX
5.47-5.725GHz	802.11ac VHT40	40	1TX
5.725-5.85GHz	802.11ac VHT40	40	1TX
5.15-5.25GHz	802.11ac VHT80	80	1TX
5.25-5.35GHz	802.11ac VHT80	80	1TX
5.47-5.725GHz	802.11ac VHT80	80	1TX
5.725-5.85GHz	802.11ac VHT80	80	1TX



Note:

- ♦ 11a, HT20 and HT40 use a combination of OFDM-BPSK, QPSK, 16QAM, 64QAM modulation.
- ♦ VHT20, VHT40, VHT80 use a combination of OFDM-BPSK, QPSK, 16QAM, 64QAM, 256QAM modulation.
- ♦ BWch is the nominal channel bandwidth.

1.1.2 Antenna Information

Ant.	Brand	Model Name	Antenna Type	Connector
1	-	-	PIFA	Mini-IPEX

Ant.	Port	Gain (dBi)		
		2.4G	5G	BT
1	1	2.93	4.16	2.93

Note 1: The EUT has one antenna.

**For 2.4GHz function:**

For IEEE 802.11 b/g/n mode (1TX/1RX)

Ant. 1 (port 1) could transmit/receive simultaneously.

**For 5GHz function:**

For IEEE 802.11 a/n/ac mode (1TX/1RX)

Ant. 1 (port 1) could transmit/receive simultaneously.

**For BT function:**

For IEEE 802.15.1 Bluetooth mode (1TX/1RX)

Ant. 1 (port 1) could transmit/receive simultaneously.

1.1.3 EUT Information

Operational Condition	
EUT Power Type	From AC Adapter / Battery
EUT Function	<input type="checkbox"/> Outdoor
	<input type="checkbox"/> Fixed P2P
Beamforming Function	<input type="checkbox"/> Indoor
	<input checked="" type="checkbox"/> Client
TPC Function	<input type="checkbox"/> With beamforming
	<input checked="" type="checkbox"/> Without beamforming
Weather Band	<input checked="" type="checkbox"/> With TPC Function
	<input type="checkbox"/> Without TPC Function
Type of EUT	<input type="checkbox"/> With 5600~5650MHz
	<input checked="" type="checkbox"/> Without 5600~5650MHz
<input checked="" type="checkbox"/>	Stand-alone
<input type="checkbox"/>	Combined (EUT where the radio part is fully integrated within another device)
	Combined Equipment - Brand Name / Model No.: ...
<input type="checkbox"/>	Plug-in radio (EUT intended for a variety of host systems)
	Host System - Brand Name / Model No.: ...
<input type="checkbox"/>	Other:



1.1.4 Mode Test Duty Cycle

Mode	DC	DCF(dB)	T(s)	VBW(Hz) $\geq 1/T$
802.11a	0.951	0.22	2.029m	1k
802.11ac VHT20	0.954	0.2	1.9m	1k
802.11ac VHT40	0.909	0.41	936.25u	3k
802.11ac VHT80	0.834	0.79	456.563u	3k

Note. If DC < 0.98, the DCF was added while measuring Output power and PSD.

1.1.5 Table for Multiple Listing

The brand/model names in the following table are all refer to the identical product.

Brand Name	Model Name	Cover	Description
DATALOGIC	MEMOR 20 WWAN	White	There are two enclosures for EUT. All samples are identical, only the color is different.
		Black	

## 1.2 Testing Applied Standards

According to the specifications of the manufacturer, the EUT must comply with the requirements of the following standards:

- ◆ 47 CFR FCC Part 15
- ◆ ANSI C63.10-2013
- ◆ KDB 789033 D02 v02r01
- ◆ KDB 414788 D01 v01r01

## 1.3 Testing Location Information

Testing Location				
<input checked="" type="checkbox"/>	HWA YA	ADD : No. 52, Huaya 1st Rd., Guishan Dist., Taoyuan City, Taiwan (R.O.C.)		
		TEL : 886-3-327-3456	FAX : 886-3-327-0973	
Test site Designation No. TW1190 with FCC.				
<input type="checkbox"/>	JHUBEI	ADD : No.8, Ln. 724, Bo'ai St., Zhubei City, Hsinchu County, Taiwan (R.O.C.)		
		TEL : 886-3-656-9065	FAX : 886-3-656-9085	
Test site Designation No. TW0006 with FCC.				

Test Condition	Test Site No.	Test Engineer	Test Environment	Test Date
AC Conduction	CO04-HY	Edward	22.4~23.9°C / 64.2~72.2%	11/Sep/2019
RF Conducted	TH06-HY	Tim	23.5~25°C / 63~68%	16/Aug/2019
Radiated	03CH09-HY	Daniel	23.1~23.9°C / 52~55%	13/Aug/2019~ 11/Sep/2019

## 1.4 Measurement Uncertainty

ISO/IEC 17025 requires that an estimate of the measurement uncertainties associated with the emissions test results be included in the report. The measurement uncertainties given below are based on a 95% confidence level (based on a coverage factor (k=2))

Test Items	Uncertainty	Remark
Conducted Emission (150kHz ~ 30MHz)	3.54 dB	Confidence levels of 95%
Radiated Emission (9kHz ~ 30MHz)	1.6 dB	Confidence levels of 95%
Radiated Emission (30MHz ~ 1,000MHz)	4.3 dB	Confidence levels of 95%
Radiated Emission (1GHz ~ 18GHz)	3.9 dB	Confidence levels of 95%
Radiated Emission (18GHz ~ 40GHz)	3.5 dB	Confidence levels of 95%
Conducted Emission	1.3 dB	Confidence levels of 95%
Temperature	0.7 °C	Confidence levels of 95%
Humidity	4 %	Confidence levels of 95%



## 2 Test Configuration of EUT

### 2.1 Test Condition

Condition Item	Abbreviation/Remark	Remark
TnomVnom	Tnom	20°C
	Vnom	120V

### 2.2 Test Channel Mode

Test Software Version	QDART_WIN_4_8
-----------------------	---------------

Mode	Power Setting		
	Radiated Setting	Conducted Setting	Production power Setting
802.11a_Nss1,(6Mbps)_1TX	-	-	-
5180MHz	22	16	14.5
5200MHz	22.5	16	14.5
5240MHz	24	16.5	14.5
5260MHz	24	16.5	14.5
5300MHz	22.5	16.5	14.5
5320MHz	21.5	16.5	14.5
5500MHz	21.5	16.5	14.5
5580MHz	24	17	14.5
5700MHz	20	16.5	14.5
5720MHz Straddle 5.47-5.725GHz	24	17	14.5
5720MHz Straddle 5.725-5.85GHz	24	17	14.5
5745MHz	24	16	14.5
5785MHz	24	16	14.5
5825MHz	24	16.5	14.5
802.11ac VHT20_Nss1,(MCS0)_1TX	-	-	-
5180MHz	21	15.5	13.5
5200MHz	22.5	15.5	13.5
5240MHz	24	15.5	13.5
5260MHz	24	15.5	13.5
5300MHz	24	15.5	13.5
5320MHz	21.5	15.5	13.5
5500MHz	21.5	15.5	13.5





Mode	Power Setting		
	Radiated Setting	Conducted Setting	Production power Setting
5580MHz	24	16	13.5
5700MHz	17.5	15.5	13.5
5720MHz Straddle 5.47-5.725GHz	24	16	13.5
5720MHz Straddle 5.725-5.85GHz	24	16	13.5
5745MHz	24	15	13.5
5785MHz	24	15	13.5
5825MHz	24	15.5	13.5
802.11ac VHT40_Nss1,(MCS0)_1TX	-	-	-
5190MHz	17.5	15	13.5
5230MHz	22	15	13.5
5270MHz	22	15	13.5
5310MHz	16.5	15	13.5
5510MHz	17.5	15	13.5
5550MHz	22	15.5	13.5
5670MHz	20.5	15	13.5
5710MHz Straddle 5.47-5.725GHz	24	15	13.5
5710MHz Straddle 5.725-5.85GHz	24	15	13.5
5755MHz	24	14.5	13.5
5795MHz	24	14.5	13.5
802.11ac VHT80_Nss1,(MCS0)_1TX	-	-	-
5210MHz	18	15	13
5290MHz	15.5	14	12
5530MHz	17	15.5	13
5690MHz Straddle 5.47-5.725GHz	22.5	15	13
5690MHz Straddle 5.725-5.85GHz	22.5	15	13
5775MHz	22.5	14.5	13

Note: The Radiated setting and Conducted setting mentioned above is the worst configuration for each other, and the worst configuration and result of that was recorded as the final power setting parameter.

### 2.3 The Worst Case Measurement Configuration

The Worst Case Mode for Following Conformance Tests	
Tests Item	AC power-line conducted emissions
Condition	AC power-line conducted measurement for line and neutral
Operating Mode	CTX
1	Adapter mode

The Worst Case Mode for Following Conformance Tests	
Tests Item	Emission Bandwidth Maximum Conducted Output Power Peak Power Spectral Density
Test Condition	Conducted measurement at transmit chains

The Worst Case Mode for Following Conformance Tests			
Tests Item	Unwanted Emissions		
Test Condition	Radiated measurement If EUT consist of multiple antenna assembly (multiple antenna are used in EUT regardless of spatial multiplexing MIMO configuration), the radiated test should be performed with highest antenna gain of each antenna type.		
Operating Mode < 1GHz	CTX		
1	Adapter mode		
Operating Mode > 1GHz	CTX		
Orthogonal Planes of EUT	X Plane	Y Plane	Z Plane
			
Worst Planes of EUT	V		

The Worst Case Mode for Following Conformance Tests	
Tests Item	Simultaneous Transmission Analysis
Test Condition	Radiated measurement
Operating Mode	Normal Link
1	Bluetooth+WLAN 5GHz
Refer to Sporton Test Report No.: Appendix G for Radiated Emission Co-location.	



## 2.4 Accessories and Support Equipment

Accessories				
Battery	Brand Name	DATALOGIC	Model Name	BY-05
	Power Rating	3.85Vdc, 3900mAh	Type	Li-ion
USB Cable	Power Cord	1.2 meter, shielded cable, w/o ferrite core		

Reminder: Regarding to more detail and other information, please refer to user manual.

Support Equipment – AC Conduction				
No.	Equipment	Brand Name	Model Name	FCC ID
1	AC adapter	Channel Well	2ACP0183	N/A

Note: Support equipment No.1 was provided by customer.

Support Equipment – RF Conducted				
No.	Equipment	Brand Name	Model Name	FCC ID
1	Notebook	DELL	E5410	DoC
2	Adapter for NB	DELL	HA65NM130	DoC

Support Equipment – Radiated Emission				
No.	Equipment	Brand Name	Model Name	FCC ID
1	AC adapter	Channel Well	2ACP0183	N/A

Note: Support equipment No.1 was provided by customer.

## 2.5 Test Setup Diagram

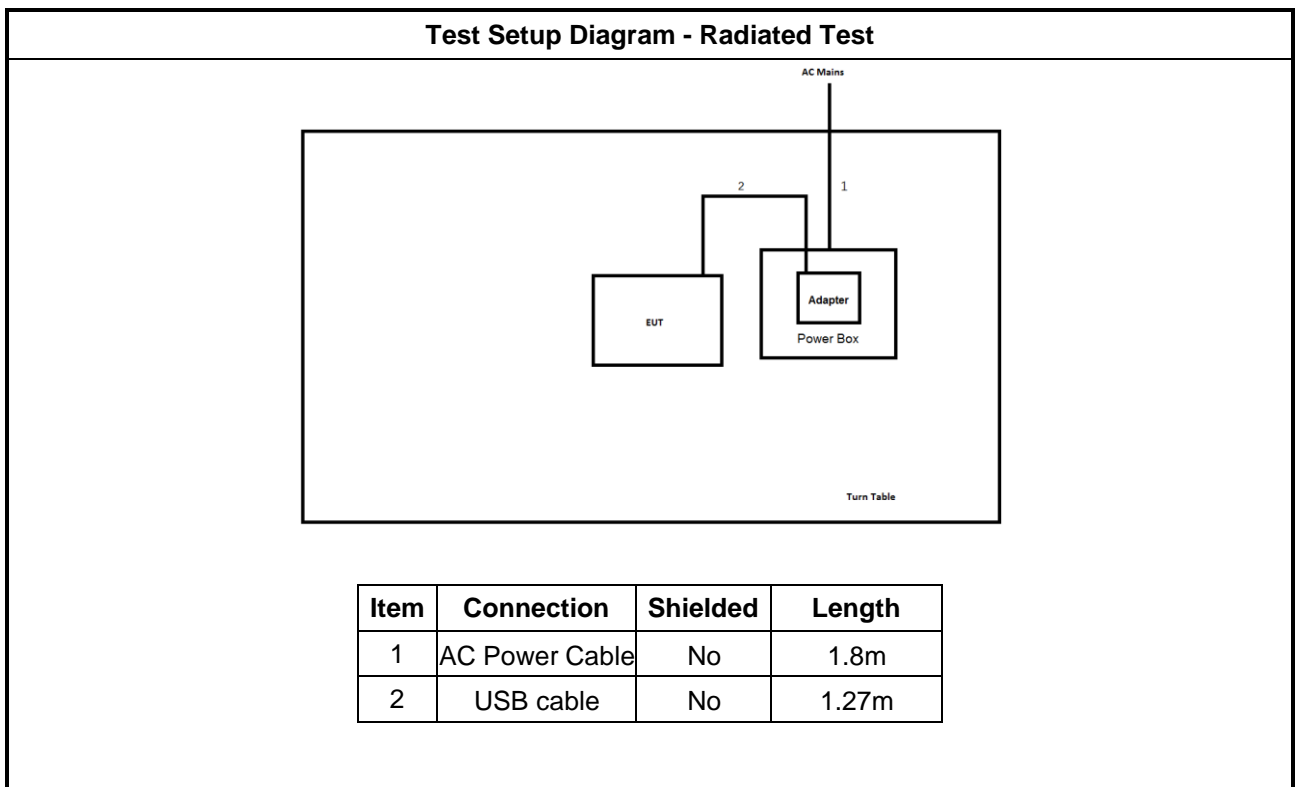
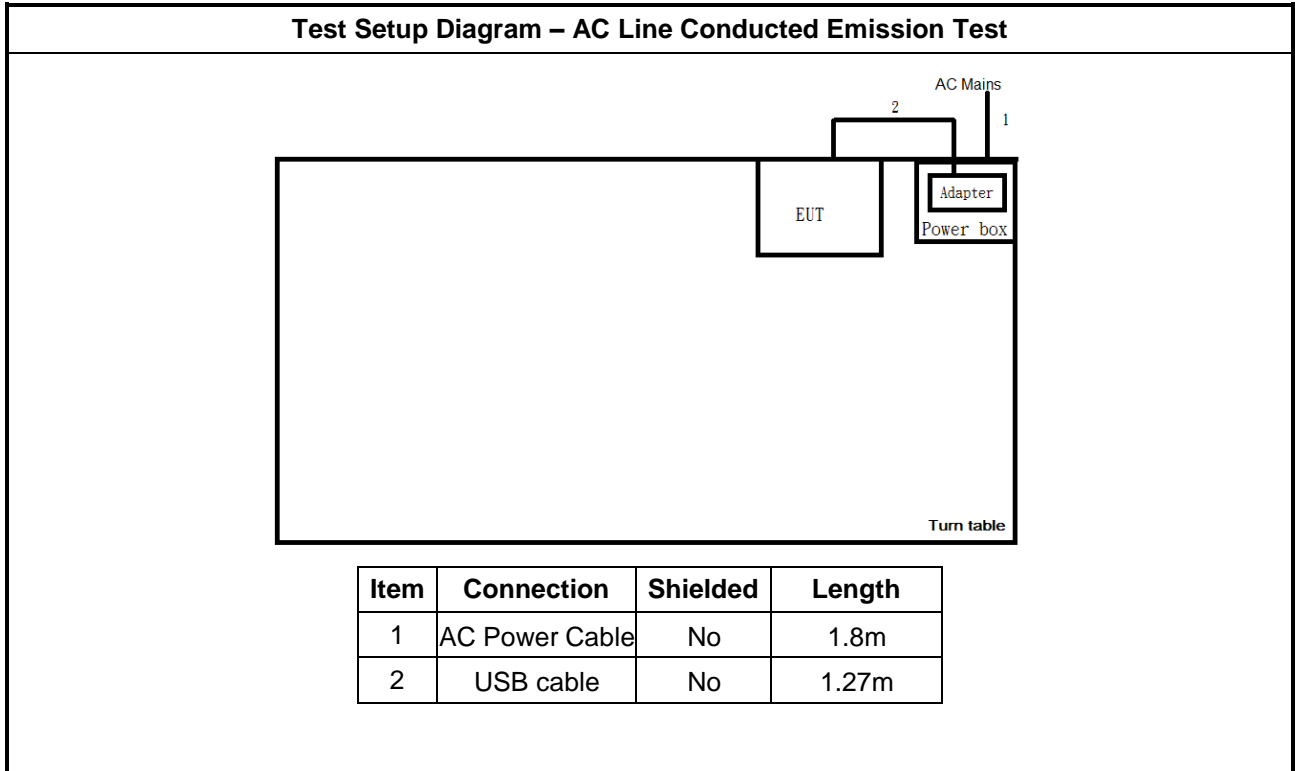



### 3 Transmitter Test Result

#### 3.1 AC Power-line Conducted Emissions

##### 3.1.1 AC Power-line Conducted Emissions Limit

AC Power-line Conducted Emissions Limit		
Frequency Emission (MHz)	Quasi-Peak	Average
0.15-0.5	66 - 56 *	56 - 46 *
0.5-5	56	46
5-30	60	50

Note 1: \* Decreases with the logarithm of the frequency.

##### 3.1.2 Measuring Instruments

Refer a test equipment and calibration data table in this test report.

##### 3.1.3 Test Procedures

Test Method
<input checked="" type="checkbox"/> Refer as ANSI C63.10-2013, clause 6.2 for AC power-line conducted emissions.

### 3.1.4 Test Setup

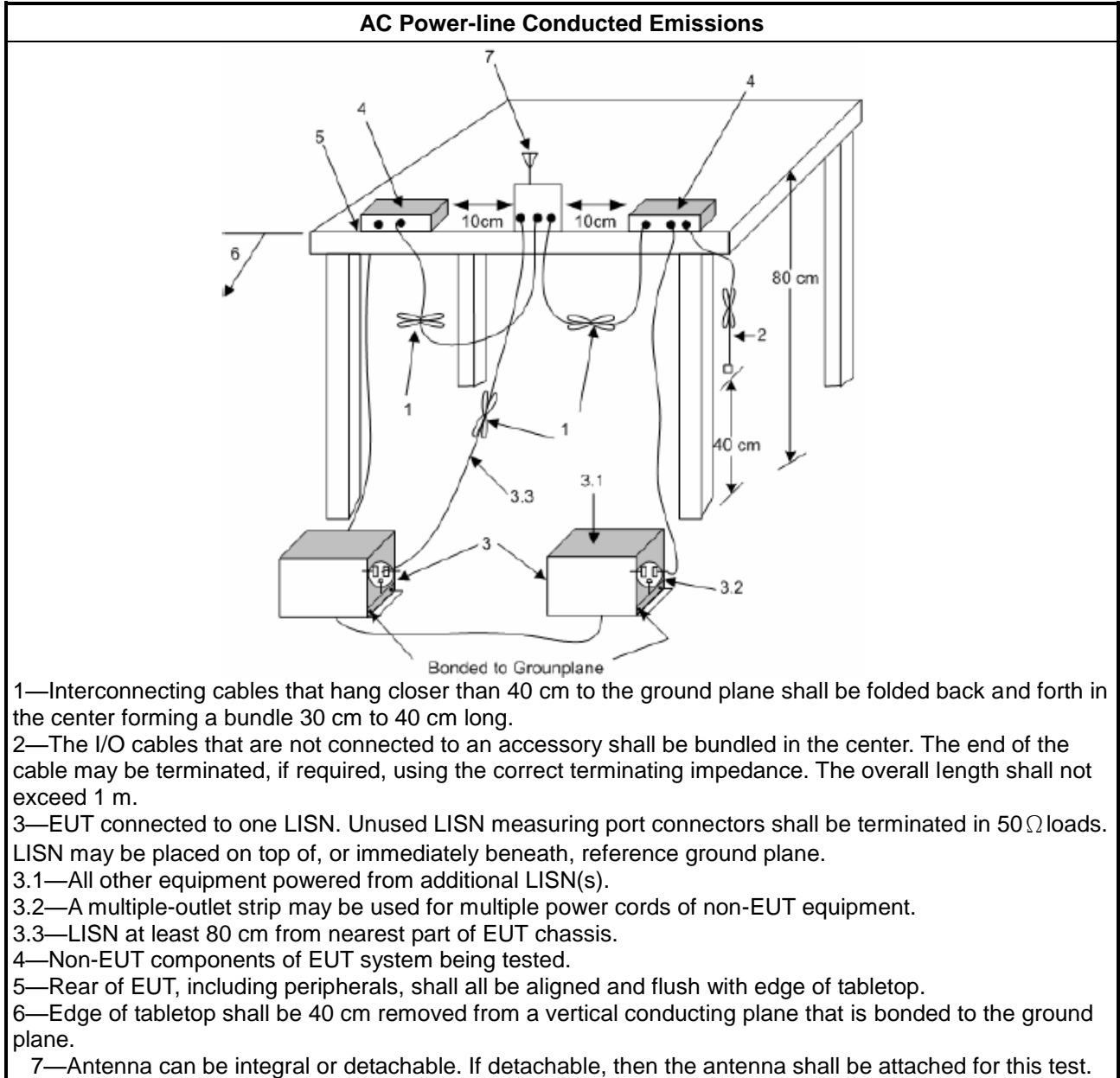

### 3.1.5 Test Result of AC Power-line Conducted Emissions

Refer as Appendix A

### 3.2 Emission Bandwidth

#### 3.2.1 Emission Bandwidth Limit

Emission Bandwidth Limit	
<b>UNII Devices</b>	
<input checked="" type="checkbox"/>	For the 5.15-5.25 GHz band, N/A
<input checked="" type="checkbox"/>	For the 5.25-5.35 GHz band, N/A
<input checked="" type="checkbox"/>	For the 5.47-5.725 GHz band, N/A
<input checked="" type="checkbox"/>	For the 5.725-5.85 GHz band, 6 dB emission bandwidth $\geq$ 500kHz.

#### 3.2.2 Measuring Instruments

Refer a test equipment and calibration data table in this test report.

#### 3.2.3 Test Procedures

Test Method	
<ul style="list-style-type: none"> <li>▪ For the emission bandwidth shall be measured using one of the options below:</li> </ul>	
<input checked="" type="checkbox"/>	Refer as KDB 789033, clause C for EBW and clause D for OBW measurement.
<input type="checkbox"/>	Refer as ANSI C63.10, clause 6.9.3 for occupied bandwidth testing.
<input type="checkbox"/>	Refer as IC RSS-Gen, clause 6.7 for bandwidth testing.

#### 3.2.4 Test Setup

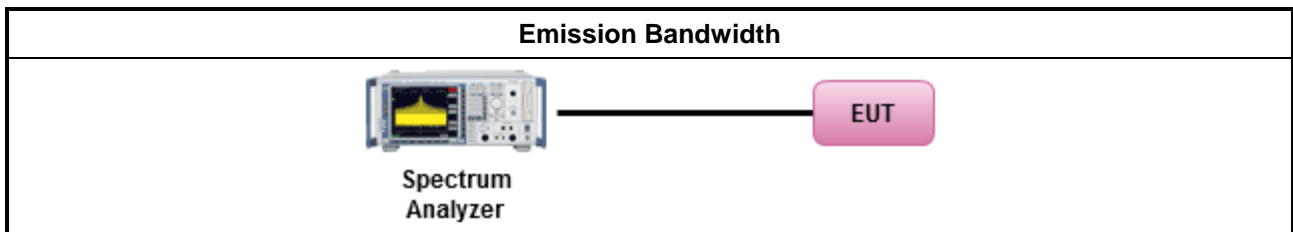

#### 3.2.5 Test Result of Emission Bandwidth

Refer as Appendix B



### 3.3 Maximum Conducted Output Power

#### 3.3.1 Maximum Conducted Output Power Limit

Maximum Conducted Output Power Limit	
<b>UNII Devices</b>	
<input checked="" type="checkbox"/> For the 5.15-5.25 GHz band:	
	<ul style="list-style-type: none"> <li>▪ Outdoor AP: the maximum conducted output power (<math>P_{Out}</math>) shall not exceed the lesser of 1 W. If <math>G_{TX} &gt; 6</math> dBi, then <math>P_{Out} = 30 - (G_{TX} - 6)</math>. e.i.r.p. at any elevation angle above 30 degrees <math>\leq 125mW</math> [21dBm]</li> <li>▪ Indoor AP: the maximum conducted output power (<math>P_{Out}</math>) shall not exceed the lesser of 1 W. If <math>G_{TX} &gt; 6</math> dBi, then <math>P_{Out} = 30 - (G_{TX} - 6)</math></li> <li>▪ Point-to-point AP: the maximum conducted output power (<math>P_{Out}</math>) shall not exceed the lesser of 1 W. If <math>G_{TX} &gt; 23</math> dBi, then <math>P_{Out} = 30 - (G_{TX} - 23)</math>.</li> <li>▪ Mobile or Portable Client: the maximum conducted output power (<math>P_{Out}</math>) shall not exceed the lesser of 250 mW. If <math>G_{TX} &gt; 6</math> dBi, then <math>P_{Out} = 24 - (G_{TX} - 6)</math>.</li> </ul>
<input checked="" type="checkbox"/> For the 5.25-5.35 GHz band, the maximum conducted output power ( $P_{Out}$ ) shall not exceed the lesser of 250 mW or $11 \text{ dBm} + 10 \log B$ , where B is the 26 dB emission bandwidth in MHz. If $G_{TX} > 6$ dBi, then $P_{Out} = 24 - (G_{TX} - 6)$ .	
<input checked="" type="checkbox"/> For the 5.47-5.725 GHz band, the maximum conducted output power ( $P_{Out}$ ) shall not exceed the lesser of 250 mW or $11 \text{ dBm} + 10 \log B$ , where B is the 26 dB emission bandwidth in MHz. If $G_{TX} > 6$ dBi, then $P_{Out} = 24 - (G_{TX} - 6)$ .	
<input checked="" type="checkbox"/> For the 5.725-5.85 GHz band:	
	<ul style="list-style-type: none"> <li>▪ Point-to-multipoint systems (P2M): the maximum conducted output power (<math>P_{Out}</math>) shall not exceed the lesser of 1 W. If <math>G_{TX} &gt; 6</math> dBi, then <math>P_{Out} = 30 - (G_{TX} - 6)</math>.</li> <li>▪ Point-to-point systems (P2P): the maximum conducted output power (<math>P_{Out}</math>) shall not exceed the lesser of 1 W.</li> </ul>
$P_{Out}$ = maximum conducted output power in dBm, $G_{TX}$ = the maximum transmitting antenna directional gain in dBi.	

#### 3.3.2 Measuring Instruments

Refer a test equipment and calibration data table in this test report.

### 3.3.3 Test Procedures

Test Method	
<ul style="list-style-type: none"> <li>Maximum Conducted Output Power</li> </ul>	
	Duty cycle $\geq 98\%$ <input type="checkbox"/> Refer as KDB 789033, clause E Method SA-2 (spectral trace averaging).
	Duty cycle $< 98\%$ <input checked="" type="checkbox"/> Refer as KDB 789033, clause E Method SA-2 Alt. (RMS detection with slow sweep speed)
	Wideband RF power meter and average over on/off periods with duty factor
	<input checked="" type="checkbox"/> Refer as KDB 789033, clause E Method PM (using an RF average power meter).
<ul style="list-style-type: none"> <li>For conducted measurement.</li> </ul>	
	<ul style="list-style-type: none"> <li>If the EUT supports multiple transmit chains using options given below: Refer as KDB 662911, In-band power measurements. Using the measure-and-sum approach, measured all transmit ports individually. Sum the power (in linear power units e.g., mW) of all ports for each individual sample and save them.</li> </ul>
	<ul style="list-style-type: none"> <li>If multiple transmit chains, EIRP calculation could be following as methods:  <math>P_{total} = P_1 + P_2 + \dots + P_n</math>            (calculated in linear unit [mW] and transfer to log unit [dBm])  <math>EIRP_{total} = P_{total} + DG</math> </li> </ul>

### 3.3.4 Test Setup

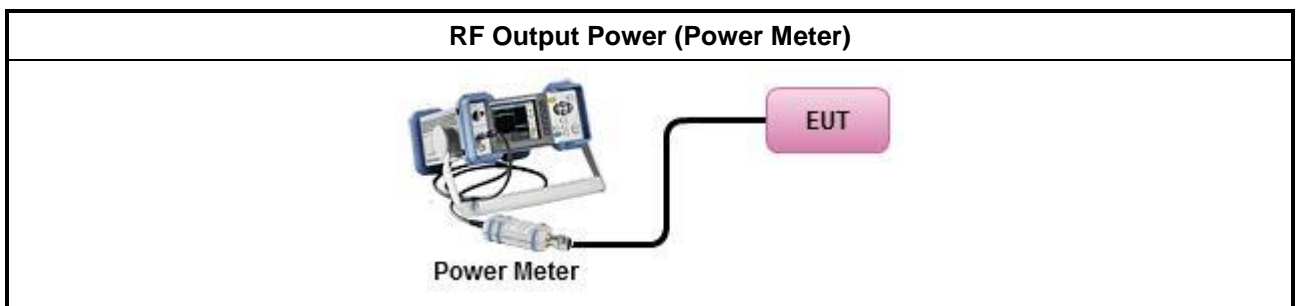
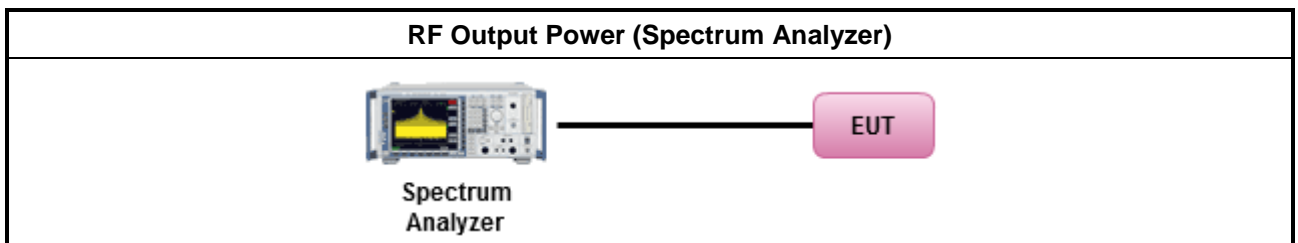

### 3.3.5 Test Result of Maximum Conducted Output Power

Refer as Appendix C

### 3.4 Peak Power Spectral Density

#### 3.4.1 Peak Power Spectral Density Limit

Peak Power Spectral Density Limit	
<b>UNII Devices</b>	
<input checked="" type="checkbox"/> For the 5.15-5.25 GHz band:	
	<ul style="list-style-type: none"> <li>▪ Outdoor AP: the peak power spectral density (PPSD) shall not exceed the lesser of 17dBm/MHz. If <math>G_{TX} &gt; 6</math> dBi, then <math>P_{Out} = 17 - (G_{TX} - 6)</math>.</li> <li>▪ Indoor AP: the peak power spectral density (PPSD) shall not exceed the lesser of 17dBm/MHz. If <math>G_{TX} &gt; 6</math> dBi, then <math>P_{Out} = 17 - (G_{TX} - 6)</math>.</li> <li>▪ Point-to-point AP: the peak power spectral density (PPSD) shall not exceed the lesser of 17dBm/MHz. If <math>G_{TX} &gt; 23</math> dBi, then <math>P_{Out} = 17 - (G_{TX} - 23)</math>.</li> <li>▪ Mobile or Portable Client: the peak power spectral density (PPSD) <math>\leq 11</math> dBm/MHz. If <math>G_{TX} &gt; 6</math> dBi, then <math>PPSD = 11 - (G_{TX} - 6)</math>.</li> </ul>
<input checked="" type="checkbox"/> For the 5.25-5.35 GHz band, the peak power spectral density (PPSD) $\leq 11$ dBm/MHz. If $G_{TX} > 6$ dBi, then $PPSD = 11 - (G_{TX} - 6)$ .	
<input checked="" type="checkbox"/> For the 5.47-5.725 GHz band, the peak power spectral density (PPSD) $\leq 11$ dBm/MHz. If $G_{TX} > 6$ dBi, then $PPSD = 11 - (G_{TX} - 6)$ .	
<input checked="" type="checkbox"/> For the 5.725-5.85 GHz band:	
	<ul style="list-style-type: none"> <li>▪ Point-to-multipoint systems (P2M): the peak power spectral density (PPSD) <math>\leq 30</math> dBm/500kHz. If <math>G_{TX} &gt; 6</math> dBi, then <math>PPSD = 30 - (G_{TX} - 6)</math>.</li> <li>▪ Point-to-point systems (P2P): the peak power spectral density (PPSD) <math>\leq 30</math> dBm/500kHz.</li> </ul>
<p><b>PPSD</b> = peak power spectral density that he same method as used to determine the conducted output power shall be used to determine the power spectral density. And power spectral density in dBm/MHz</p> <p><b>G<sub>TX</sub></b> = the maximum transmitting antenna directional gain in dBi.</p>	

#### 3.4.2 Measuring Instruments

Refer a test equipment and calibration data table in this test report.

### 3.4.3 Test Procedures

Test Method	
<ul style="list-style-type: none"> <li>▪ Peak power spectral density procedures that the same method as used to determine the conducted output power shall be used to determine the peak power spectral density and use the peak search function on the spectrum analyzer to find the peak of the spectrum. For the peak power spectral density shall be measured using below options:</li> </ul>	
<input type="checkbox"/>	Refer as KDB 789033, F)5) power spectral density can be measured using resolution bandwidths < 1 MHz provided that the results are integrated over 1 MHz bandwidth Duty cycle ≥ 98%
<input type="checkbox"/>	Refer as KDB 789033, clause E Method SA-2 (spectral trace averaging). Duty cycle < 98%
<input checked="" type="checkbox"/>	Refer as KDB 789033, clause E Method SA-2 Alt. (RMS detection with slow sweep speed)
<ul style="list-style-type: none"> <li>▪ For conducted measurement.</li> </ul>	
<ul style="list-style-type: none"> <li>▪ If the EUT supports multiple transmit chains using options given below:               <ul style="list-style-type: none"> <li>▪ Measure and sum the spectra across the outputs. Refer as KDB 662911, In-band power spectral density (PSD). Sample all transmit ports simultaneously using a spectrum analyzer for each transmit port. Where the trace bin-by-bin of each transmit port summing can be performed. (i.e., in the first spectral bin of output 1 is summed with that in the first spectral bin of output 2 and that from the first spectral bin of output 3, and so on up to the NTX output to obtain the value for the first frequency bin of the summed spectrum.). Add up the amplitude (power) values for the different transmit chains and use this as the new data trace.</li> </ul> </li> <li>▪ If multiple transmit chains, EIRP PPSD calculation could be following as methods:  <math>PPSD_{total} = PPSD_1 + PPSD_2 + \dots + PPSD_n</math>            (calculated in linear unit [mW] and transfer to log unit [dBm])  <math>EIRP_{total} = PPSD_{total} + DG</math> </li> </ul>	

### 3.4.4 Test Setup

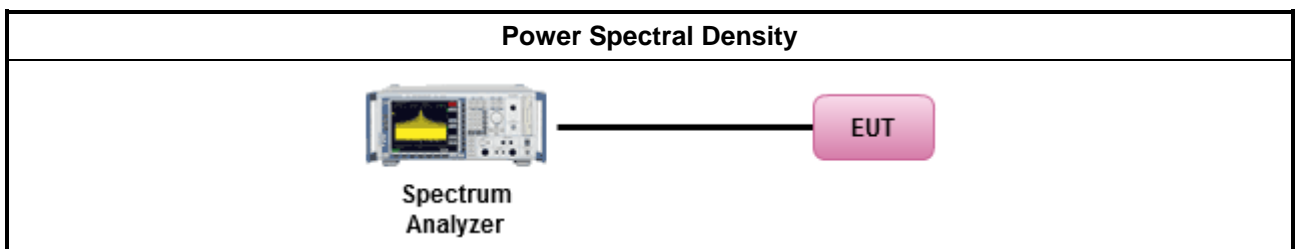

### 3.4.5 Test Result of Peak Power Spectral Density

Refer as Appendix D

### 3.5 Unwanted Emissions

#### 3.5.1 Transmitter Radiated Unwanted Emissions Limit

Unwanted emissions below 1 GHz and restricted band emissions above 1GHz limit			
Frequency Range (MHz)	Field Strength (uV/m)	Field Strength (dBuV/m)	Measure Distance (m)
0.009~0.490	2400/F(kHz)	48.5 - 13.8	300
0.490~1.705	24000/F(kHz)	33.8 - 23	30
1.705~30.0	30	29	30
30~88	100	40	3
88~216	150	43.5	3
216~960	200	46	3
Above 960	500	54	3

Note 1: Test distance for frequencies at or above 30 MHz, measurements may be performed at a distance other than the limit distance provided they are not performed in the near field and the emissions to be measured can be detected by the measurement equipment. When performing measurements at a distance other than that specified, the results shall be extrapolated to the specified distance using an extrapolation factor of 20 dB/decade (inverse of linear distance for field-strength measurements, inverse of linear distance-squared for power-density measurements).

Note 2: Test distance for frequencies at below 30 MHz, measurements may be performed at a distance closer than the EUT limit distance; however, an attempt should be made to avoid making measurements in the near field. When performing measurements below 30 MHz at a closer distance than the limit distance, the results shall be extrapolated to the specified distance by either making measurements at a minimum of two or more distances on at least one radial to determine the proper extrapolation factor or by using the square of an inverse linear distance extrapolation factor (40 dB/decade). The test report shall specify the extrapolation method used to determine compliance of the EUT.

Note 3: Using the distance of 1m during the test for above 18 GHz, and the test value to correct for the distance factor at 3m.

Un-restricted band emissions above 1GHz Limit	
Operating Band	Limit
5.15 - 5.25 GHz	e.i.r.p. -27 dBm [68.2 dBuV/m@3m]
5.25 - 5.35 GHz	e.i.r.p. -27 dBm [68.2 dBuV/m@3m]
5.47 - 5.725 GHz	e.i.r.p. -27 dBm [68.2 dBuV/m@3m]
5.725 - 5.85 GHz	5.650-5700 GHz: e.i.r.p. -27 ~ 10 dBm [68.2 ~ 105.2 dBuV/m@3m] 5.700-5720 GHz: e.i.r.p. 10 ~ 15.6 dBm [105.2 ~ 110.8 dBuV/m@3m] 5.720-5725 GHz: e.i.r.p. 15.6 ~ 27 dBm [110.8 ~ 122.2 dBuV/m@3m] 5.850-5.855 GHz: e.i.r.p. 27 ~ 15.6 dBm [122.2 ~ 110.8 dBuV/m@3m] 5.855-5.875 GHz: e.i.r.p. 15.6 ~ 10 dBm [110.8 ~ 105.2 dBuV/m@3m] 5.875-5.925 GHz: e.i.r.p. 10 ~ -27 dBm [105.2 ~ 68.2dBuV/m@3m] Other un-restricted band: e.i.r.p. -27 dBm [68.2 dBuV/m@3m]

Note 1: Measurements may be performed at a distance other than the limit distance provided they are not performed in the near field and the emissions to be measured can be detected by the measurement equipment. When performing measurements at a distance other than that specified, the results shall be extrapolated to the specified distance using an extrapolation factor of 20 dB/decade (inverse of linear distance for field-strength measurements, inverse of linear distance-squared for power-density measurements).

### 3.5.2 Measuring Instruments

Refer a test equipment and calibration data table in this test report.

### 3.5.3 Test Procedures

Test Method	
<ul style="list-style-type: none"> <li>▪ Measurements may be performed at a distance other than the limit distance provided they are not performed in the near field and the emissions to be measured can be detected by the measurement equipment. Measurements shall not be performed at a distance greater than 30 m for frequencies above 30 MHz, unless it can be further demonstrated that measurements at a distance of 30 m or less are impractical. When performing measurements at a distance other than that specified, the results shall be extrapolated to the specified distance using an extrapolation factor of 20 dB/decade (inverse of linear distance for field-strength measurements, inverse of linear distance-squared for power-density measurements).</li> </ul>	
<ul style="list-style-type: none"> <li>▪ The average emission levels shall be measured in [duty cycle <math>\geq</math> 98 or duty factor].</li> </ul>	
<ul style="list-style-type: none"> <li>▪ For the transmitter unwanted emissions shall be measured using following options below:</li> </ul>	
	<ul style="list-style-type: none"> <li>▪ Refer as KDB 789033, clause G)2) for unwanted emissions into non-restricted bands.</li> </ul>
	<ul style="list-style-type: none"> <li>▪ Refer as KDB 789033, clause G)1) for unwanted emissions into restricted bands.</li> </ul>
<input checked="" type="checkbox"/>	Refer as KDB 789033, G)6) Method VB (ANSI C63.10, clause 4.1.4.2.3), Reduced VBW.
<input checked="" type="checkbox"/>	Refer as KDB 789033, clause G)5) (ANSI C63.10, clause 4.1.4.2.2), measurement procedure peak limit.
<ul style="list-style-type: none"> <li>▪ For radiated measurement.</li> </ul>	
	<ul style="list-style-type: none"> <li>▪ Refer as ANSI C63.10, clause 6.4 for radiated emissions below 30 MHz and test distance is 3m.</li> </ul>
	<ul style="list-style-type: none"> <li>▪ Refer as ANSI C63.10, clause 6.5 for radiated emissions 30 MHz to 1 GHz and test distance is 3m.</li> </ul>
	<ul style="list-style-type: none"> <li>▪ Refer as ANSI C63.10, clause 6.6 for radiated emissions above 1GHz.</li> </ul>
<ul style="list-style-type: none"> <li>▪ The any unwanted emissions level shall not exceed the fundamental emission level.</li> </ul>	
<ul style="list-style-type: none"> <li>▪ All amplitude of spurious emissions that are attenuated by more than 20 dB below the permissible value has no need to be reported.</li> </ul>	
<ul style="list-style-type: none"> <li>▪ Use the following spectrum analyzer settings:</li> </ul>	
	<ul style="list-style-type: none"> <li>▪ Set RBW=100 kHz for <math>f &lt; 1</math> GHz; VBW=3 * RBW; Sweep = auto; Detector function = peak; Trace = max hold.</li> </ul>
	<ul style="list-style-type: none"> <li>▪ Set RBW = 1 MHz, VBW= 3MHz for <math>f \geq 1</math> GHz for peak measurement. For average measurement, refer as 1.1.4.</li> </ul>
<ul style="list-style-type: none"> <li>▪ KDB 414788 Open-Field Test Sites and Chamber Correlation Justification.</li> </ul>	
	<ul style="list-style-type: none"> <li>▪ Based on FCC 15.31 (f) (2): measurements may be performed at a distance closer than that specified in regulations; however, an attempt should be made to avoid making measurements in the near field.</li> </ul>
	<ul style="list-style-type: none"> <li>▪ Open-field site and chamber correlation testing had been performed and chamber measured test result is the worst case test result.</li> </ul>

### 3.5.4 Test Setup

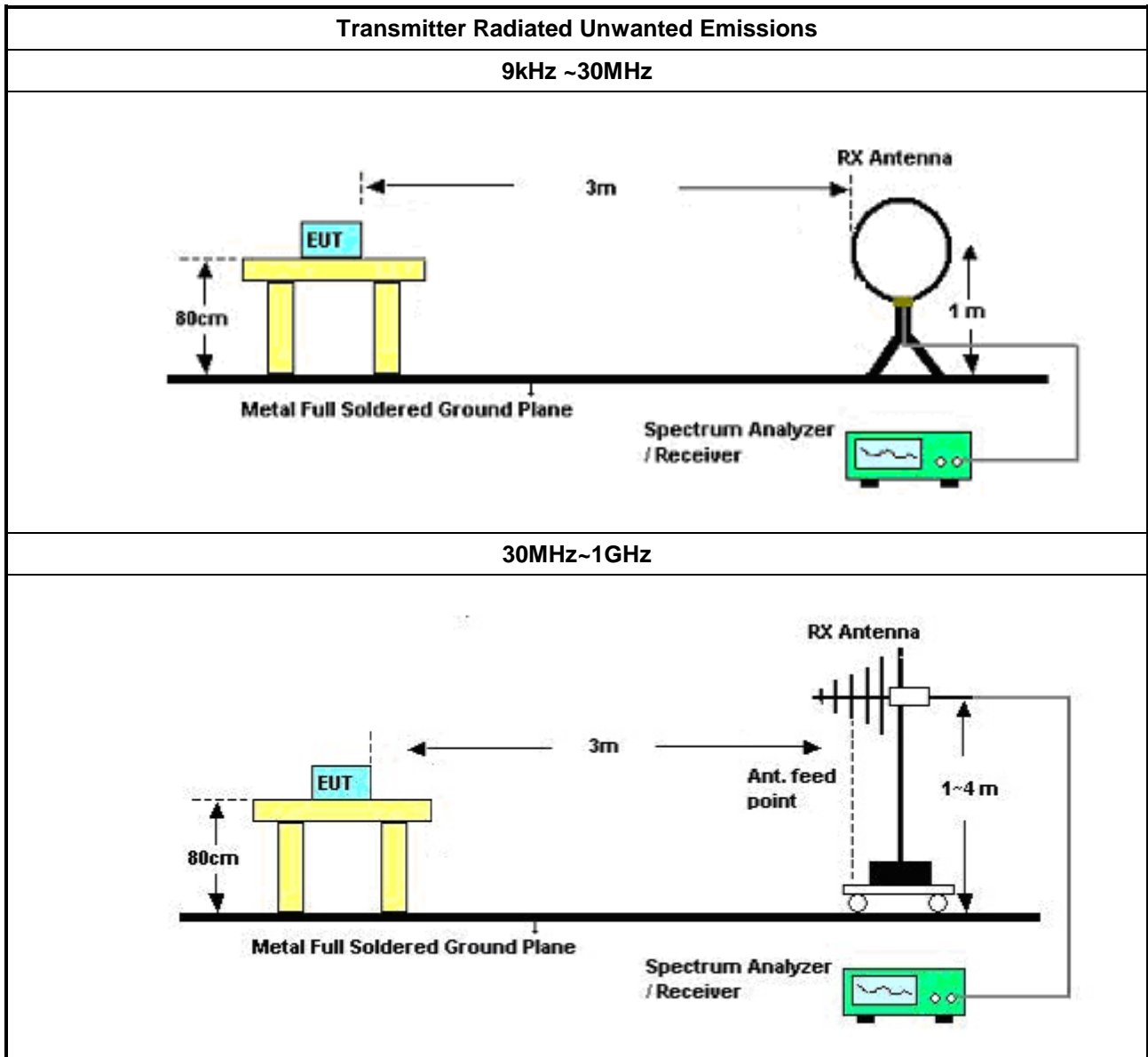

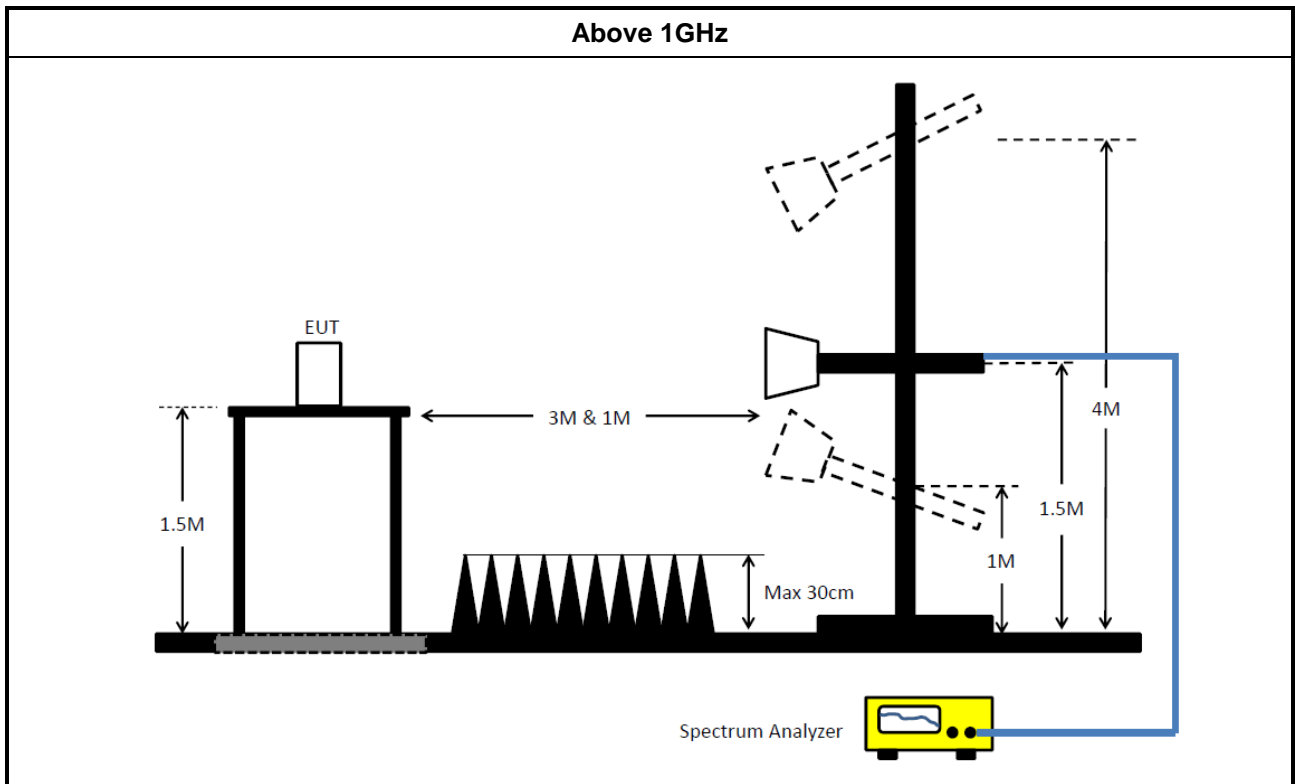

### 3.5.5 Transmitter Unwanted Emissions (Below 30MHz)

The amplitude of spurious emissions which are attenuated by more than 20dB below the permissible value has no need to be reported.

### 3.5.6 Test Result of Transmitter Unwanted Emissions

Refer as Appendix E



## 4 Test Equipment and Calibration Data

### Instrument for AC Conduction

Instrument	Manufacturer	Model No.	Serial No.	Spec.	Calibration Date	Calibration Due Date
EMC Receiver	R&S	ESR3	102052	9kHz ~ 3.6GHz	09/Apr/2019	08/Apr/2020
LISN	R&S	ENV216	101295	9kHz ~ 30MHz	08/Nov/2018	07/Nov/2019
RF Cable-CON	MTJ	RG142	CB002-CO	9kHz ~ 200MHz	17/Sep/2018	16/Sep/2019
AC POWER	APC	AFC-11005G	F310050055	47Hz~63Hz 5~300V	NCR	NCR
Impuls Begrenzer Pulse Limiter	SCHWARZBECK	VTSD 9561-F	9561-F041	9 kHz ~ 30 MHz	12/Oct/2018	11/Oct/2019

**NCR : Non-Calibration Require**

### Instrument for Conducted Test

Instrument	Manufacturer	Model No.	Serial No.	Spec.	Calibration Date	Calibration Due Date
Signal Analyzer	R&S	FSV 40	101013	10KHz ~ 40GHz	13/Mar/2019	12/Mar/2020
Pulse Power Sensor	Anritsu	MA2411B	1027452	300MHz ~ 40GHz	14/Mar/2019	13/Mar/2020
Power Meter	Anritsu	ML2495A	1124009	300MHz ~ 40GHz	14/Mar/2019	13/Mar/2020
Cable 0.2m	HUBER	MY10710/4	RF Cable - 01	30MHz ~18G	10/Jan/2019	09/Jan/2020
Cable 0.2m	HUBER	MY10711/4	RF Cable - 02	30MHz ~18G	10/Jan/2019	09/Jan/2020
Cable 1.5m	HUBER	MY33066/4	RF Cable - 30	30MHz ~18G	10/Jan/2019	09/Jan/2020
SMB100A Signal Generator	R&S	SMB100A03	181147	100kHz~40GHz	12/Nov/2018	10/Nov/2020

### Instrument for Radiated Test

Instrument	Manufacturer	Model No.	Serial No.	Spec.	Calibration Date	Calibration Due Date
3m Semi Anechoic Chamber	TDK	SAC-3M	03CH09-HY	30MHz ~ 1GHz	22/Apr/2019	21/Apr/2020
3m Semi Anechoic Chamber	TDK	SAC-3M	03CH09-HY	1GHz ~ 18GHz	13/Jun/2019	12/Jun/2020
Microwave System Prempplier	KEYSIGHT	87422A	MY53270197	1GHz ~ 18GHz	30/Nov/2018	29/Nov/2019
Amplifier	EMC	EMC9135	980232	9KHz~1GHz	22/Apr/2019	21/Apr/2020
EMI Test Receiver	R&S	ESR3	102052	9kHz ~ 3.6GHz	09/Apr/2019	08/Apr/2020
Spectrum Analyzer	R&S	FSP30	100793	9 kHz ~ 30GHz	05/Jun/2019	04/Jun/2020
Bilog Antenna & 5dB Attenuator	TESEQ & MTJ	CBL6111D & MTJ6102-05	35418 / 3	30MHz~1GHz	02/Oct/2018	03/Oct/2019
Double Ridged Guide Horn Antenna	SCHWARZBECK	BBHA 9120 D	BBHA9120 D 1534	1GHz~18GHz	22/May/2019	21/May/2020
Broadband Horn Antenna	SCHWARZBECK	BBHA 9170	BBHA9170614	18GHz~40GHz	22/May/2019	21/May/2020
Preamplifier	MITEQ	TTA1840-35-HG	1864481	18GHz ~ 40GHz	24/Aug/2018	23/Aug/2019
Preamplifier	MITEQ	TTA1840-35-HG	1864481	18GHz ~ 40GHz	05/Aug/2019	04/Aug/2020
Loop Antenna	TESEQ	HLA 6120	31244	9k-30MHz	15/Mar/2019	14/Mar/2020
LF-CABLE-20190218	Jye Bao	RG142	CB028	9kHz ~ 1GHz	18/Feb/2019	17/Feb/2020
RF Cable-high	HUBER+SUHNER	SUCOFLEX104	SN 556626/4 + 556627	1GHz ~ 40GHz	13/Mar/2019	12/Mar/2020



AC Power-line Conducted Emissions Result

Operating Mode	1	Power Phase	Neutral
Operating Function	Adapter mode		

11/09/2019

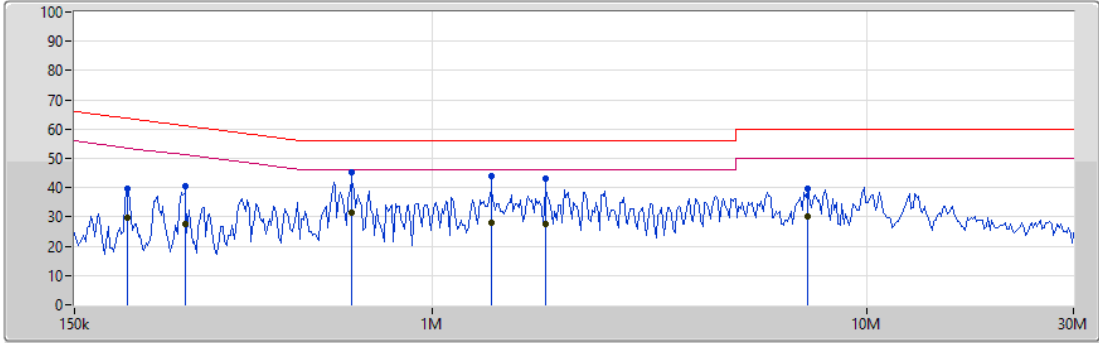

Legend for graph:

- Lim.PK (Red line)
- PK (Blue line)
- Lim.AV (Pink line)
- AV (Green line)

Type	Freq (Hz)	Level (dBuV)	Limit (dBuV)	Margin (dB)	Factor (dB)	Condition	Comment	Raw (dBuV)	LISN (dB)	CL (dB)	AT (dB)
QP	198.194k	39.74	63.69	-23.95	19.47	Neutral	-	20.27	9.59	0.01	9.87
AV	198.194k	29.55	53.69	-24.14	19.47	Neutral	-	10.08	9.59	0.01	9.87
QP	269.806k	40.55	61.12	-20.57	19.47	Neutral	-	21.08	9.59	0.01	9.87
AV	269.806k	27.71	51.12	-23.41	19.47	Neutral	-	8.24	9.59	0.01	9.87
QP	654.116k	45.40	56.00	-10.60	19.48	Neutral	"Worst"	25.92	9.59	0.01	9.88
AV	654.116k	31.65	46.00	-14.35	19.48	Neutral	-	12.17	9.59	0.01	9.88
QP	1.366M	43.87	56.00	-12.13	19.51	Neutral	-	24.36	9.60	0.03	9.88
AV	1.366M	27.86	46.00	-18.14	19.51	Neutral	-	8.35	9.60	0.03	9.88
QP	1.823M	42.91	56.00	-13.09	19.53	Neutral	-	23.38	9.61	0.03	9.89
AV	1.823M	27.57	46.00	-18.43	19.53	Neutral	-	8.04	9.61	0.03	9.89
QP	7.341M	39.64	60.00	-20.36	19.60	Neutral	-	20.04	9.65	0.06	9.89
AV	7.341M	30.08	50.00	-19.92	19.60	Neutral	-	10.48	9.65	0.06	9.89



AC Power-line Conducted Emissions Result

Operating Mode	1	Power Phase	Line
Operating Function	Adapter mode		

11/09/2019

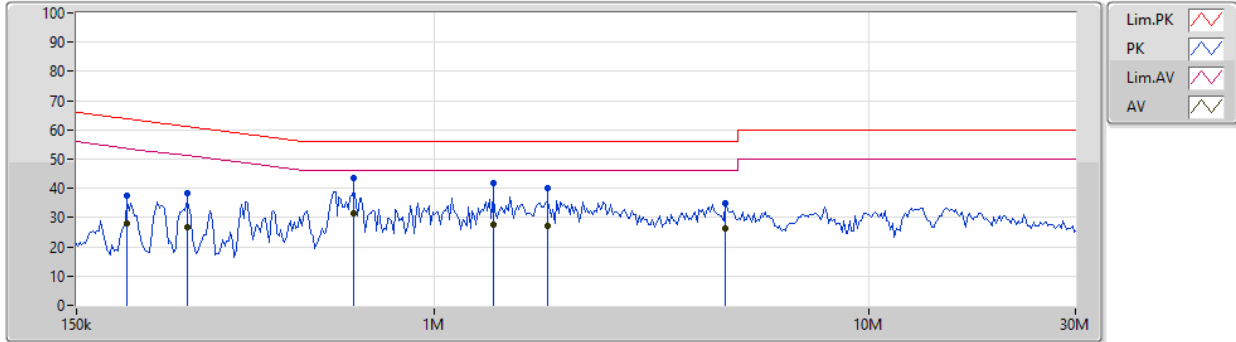

Type	Freq (Hz)	Level (dBuV)	Limit (dBuV)	Margin (dB)	Factor (dB)	Condition	Comment	Raw (dBuV)	LISN (dB)	CL (dB)	AT (dB)
QP	196.231k	37.50	63.76	-26.26	19.48	Line	-	18.02	9.60	0.01	9.87
AV	196.231k	27.99	53.76	-25.77	19.48	Line	-	8.51	9.60	0.01	9.87
QP	269.806k	38.16	61.12	-22.96	19.48	Line	-	18.68	9.60	0.01	9.87
AV	269.806k	26.84	51.12	-24.28	19.48	Line	-	7.36	9.60	0.01	9.87
QP	654.116k	43.32	56.00	-12.68	19.49	Line	"Worst"	23.83	9.60	0.01	9.88
AV	654.116k	31.58	46.00	-14.42	19.49	Line	-	12.09	9.60	0.01	9.88
QP	1.366M	41.74	56.00	-14.26	19.52	Line	-	22.22	9.61	0.03	9.88
AV	1.366M	27.57	46.00	-18.43	19.52	Line	-	8.05	9.61	0.03	9.88
QP	1.823M	40.14	56.00	-15.86	19.54	Line	-	20.60	9.62	0.03	9.89
AV	1.823M	27.28	46.00	-18.72	19.54	Line	-	7.74	9.62	0.03	9.89
QP	4.691M	34.85	56.00	-21.15	19.58	Line	-	15.27	9.64	0.05	9.89
AV	4.691M	26.26	46.00	-19.74	19.58	Line	-	6.68	9.64	0.05	9.89

**Summary**

Mode	Max-N dB (Hz)	Max-OBW (Hz)	ITU-Code	Min-N dB (Hz)	Min-OBW (Hz)
5.15-5.25GHz	-	-	-	-	-
802.11a_Nss1,(6Mbps)_1TX	24.51M	16.552M	16M6D1D	23.94M	16.522M
802.11ac VHT20_Nss1,(MCS0)_1TX	25.41M	17.751M	17M8D1D	24.06M	17.691M
802.11ac VHT40_Nss1,(MCS0)_1TX	41.76M	36.222M	36M2D1D	41.34M	36.162M
802.11ac VHT80_Nss1,(MCS0)_1TX	84.12M	75.562M	75M6D1D	84.12M	75.562M
5.25-5.35GHz	-	-	-	-	-
802.11a_Nss1,(6Mbps)_1TX	24.48M	16.582M	16M6D1D	23.37M	16.552M
802.11ac VHT20_Nss1,(MCS0)_1TX	25.44M	17.721M	17M7D1D	25.02M	17.691M
802.11ac VHT40_Nss1,(MCS0)_1TX	41.7M	36.222M	36M2D1D	41.64M	36.102M
802.11ac VHT80_Nss1,(MCS0)_1TX	84.24M	75.562M	75M6D1D	84.24M	75.562M
5.47-5.725GHz	-	-	-	-	-
802.11a_Nss1,(6Mbps)_1TX	25.2M	16.642M	16M6D1D	17.595M	13.313M
802.11ac VHT20_Nss1,(MCS0)_1TX	25.68M	17.751M	17M8D1D	17.49M	13.898M
802.11ac VHT40_Nss1,(MCS0)_1TX	41.82M	36.222M	36M2D1D	35.7M	32.954M
802.11ac VHT80_Nss1,(MCS0)_1TX	83.64M	75.802M	75M8D1D	76.95M	72.414M
5.725-5.85GHz	-	-	-	-	-
802.11a_Nss1,(6Mbps)_1TX	16.26M	16.612M	16M6D1D	3.14M	5.517M
802.11ac VHT20_Nss1,(MCS0)_1TX	16.86M	17.781M	17M8D1D	3.76M	4.998M
802.11ac VHT40_Nss1,(MCS0)_1TX	36.24M	36.222M	36M2D1D	3.14M	3.998M
802.11ac VHT80_Nss1,(MCS0)_1TX	73.92M	75.682M	75M7D1D	3.14M	4.938M

**Max-N dB** = Maximum 6dB down bandwidth for 5.725-5.85GHz band / Maximum 26dB down bandwidth for other band;

**Max-OBW** = Maximum 99% occupied bandwidth;

**Min-N dB** = Minimum 6dB down bandwidth for 5.725-5.85GHz band / Maximum 26dB down bandwidth for other band;

**Min-OBW** = Minimum 99% occupied bandwidth;

**Result**

Mode	Result	Limit (Hz)	Port 1-N dB (Hz)	Port 1-OBW (Hz)
802.11a_Nss1,(6Mbps)_1TX	-	-	-	-
5180MHz_TnomVnom	Pass	Inf	24.51M	16.552M
5200MHz_TnomVnom	Pass	Inf	23.94M	16.522M
5240MHz_TnomVnom	Pass	Inf	24M	16.552M
5260MHz_TnomVnom	Pass	Inf	23.67M	16.552M
5300MHz_TnomVnom	Pass	Inf	23.37M	16.552M
5320MHz_TnomVnom	Pass	Inf	24.48M	16.582M
5500MHz_TnomVnom	Pass	Inf	23.94M	16.582M
5580MHz_TnomVnom	Pass	Inf	25.11M	16.552M
5700MHz_TnomVnom	Pass	Inf	25.2M	16.642M
5720MHz Straddle 5.47-5.725GHz_TnomVnom	Pass	Inf	17.595M	13.313M
5720MHz Straddle 5.725-5.85GHz_TnomVnom	Pass	500k	3.14M	5.517M
5745MHz_TnomVnom	Pass	500k	16.26M	16.612M
5785MHz_TnomVnom	Pass	500k	16.26M	16.552M
5825MHz_TnomVnom	Pass	500k	15.75M	16.552M
802.11ac VHT20_Nss1,(MCS0)_1TX	-	-	-	-
5180MHz_TnomVnom	Pass	Inf	24.69M	17.721M
5200MHz_TnomVnom	Pass	Inf	24.06M	17.751M
5240MHz_TnomVnom	Pass	Inf	25.41M	17.691M
5260MHz_TnomVnom	Pass	Inf	25.44M	17.721M
5300MHz_TnomVnom	Pass	Inf	25.14M	17.721M
5320MHz_TnomVnom	Pass	Inf	25.02M	17.691M
5500MHz_TnomVnom	Pass	Inf	24.45M	17.751M
5580MHz_TnomVnom	Pass	Inf	24.72M	17.691M
5700MHz_TnomVnom	Pass	Inf	25.68M	17.721M
5720MHz Straddle 5.47-5.725GHz_TnomVnom	Pass	Inf	17.49M	13.898M
5720MHz Straddle 5.725-5.85GHz_TnomVnom	Pass	500k	3.76M	4.998M
5745MHz_TnomVnom	Pass	500k	15.93M	17.781M
5785MHz_TnomVnom	Pass	500k	16.86M	17.751M
5825MHz_TnomVnom	Pass	500k	15.87M	17.691M
802.11ac VHT40_Nss1,(MCS0)_1TX	-	-	-	-
5190MHz_TnomVnom	Pass	Inf	41.34M	36.222M
5230MHz_TnomVnom	Pass	Inf	41.76M	36.162M
5270MHz_TnomVnom	Pass	Inf	41.64M	36.102M
5310MHz_TnomVnom	Pass	Inf	41.7M	36.222M
5510MHz_TnomVnom	Pass	Inf	41.82M	36.222M
5550MHz_TnomVnom	Pass	Inf	41.76M	36.222M
5670MHz_TnomVnom	Pass	Inf	41.7M	36.162M
5710MHz Straddle 5.47-5.725GHz_TnomVnom	Pass	Inf	35.7M	32.954M
5710MHz Straddle 5.725-5.85GHz_TnomVnom	Pass	500k	3.14M	3.998M
5755MHz_TnomVnom	Pass	500k	36.24M	36.162M
5795MHz_TnomVnom	Pass	500k	35.34M	36.222M
802.11ac VHT80_Nss1,(MCS0)_1TX	-	-	-	-
5210MHz_TnomVnom	Pass	Inf	84.12M	75.562M



Mode	Result	Limit (Hz)	Port 1-N dB (Hz)	Port 1-OBW (Hz)
5290MHz_TnomVnom	Pass	Inf	84.24M	75.562M
5530MHz_TnomVnom	Pass	Inf	83.64M	75.802M
5690MHz Straddle 5.47-5.725GHz_TnomVnom	Pass	Inf	76.95M	72.414M
5690MHz Straddle 5.725-5.85GHz_TnomVnom	Pass	500k	3.14M	4.938M
5775MHz_TnomVnom	Pass	500k	73.92M	75.682M

Port X-N dB = Port X 6dB down bandwidth for 5.725-5.85GHz band / 26dB down bandwidth for other band

Port X-OBW = Port X 99% occupied bandwidth;

802.11a\_Nss1,(6Mbps)\_1TX

EBW

5180MHz

16/08/2019

CF  
5.18GHz  
Span  
60MHz  
RBW  
300kHz  
VBW  
1MHz  
Sweep Time  
100ms  
Detector Type  
Peak  
Port1

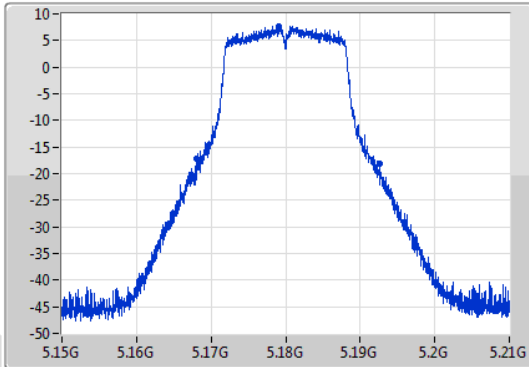

CF  
5.18GHz  
Span  
60MHz  
RBW  
200kHz  
VBW  
1MHz  
Sweep Time  
100ms  
Detector Type  
Sample

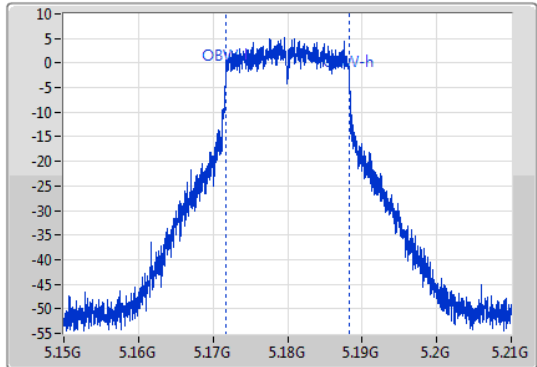

26dB(Hz)	Fl-26dB(Hz)	Fh-26dB(Hz)	OBW(Hz)	Fl-OBW(Hz)	Fh-OBW(Hz)	Limit(Hz)	Port
24.51M	5.16812G	5.19263G	16.552M	5.171694G	5.188246G	Inf	1

802.11a\_Nss1,(6Mbps)\_1TX

EBW

5200MHz

16/08/2019

CF  
5.2GHz  
Span  
60MHz  
RBW  
300kHz  
VBW  
1MHz  
Sweep Time  
100ms  
Detector Type  
Peak  
Port1

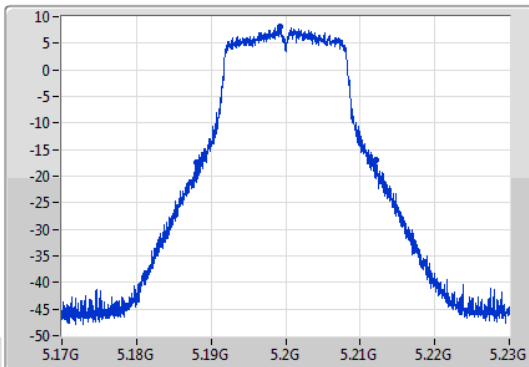

CF  
5.2GHz  
Span  
60MHz  
RBW  
200kHz  
VBW  
1MHz  
Sweep Time  
100ms  
Detector Type  
Sample

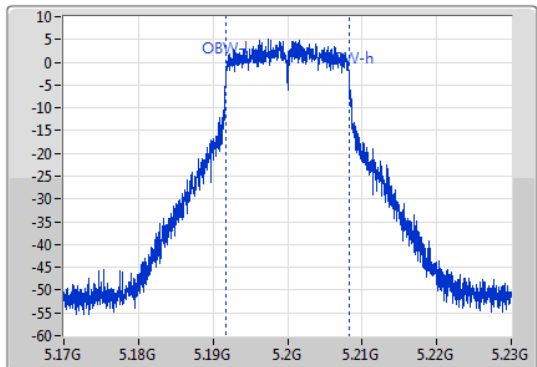

26dB(Hz)	Fl-26dB(Hz)	Fh-26dB(Hz)	OBW(Hz)	Fl-OBW(Hz)	Fh-OBW(Hz)	Limit(Hz)	Port
23.94M	5.18812G	5.21206G	16.522M	5.191724G	5.208246G	Inf	1

### 802.11a\_Nss1,(6Mbps)\_1TX

EBW

5240MHz

16/08/2019

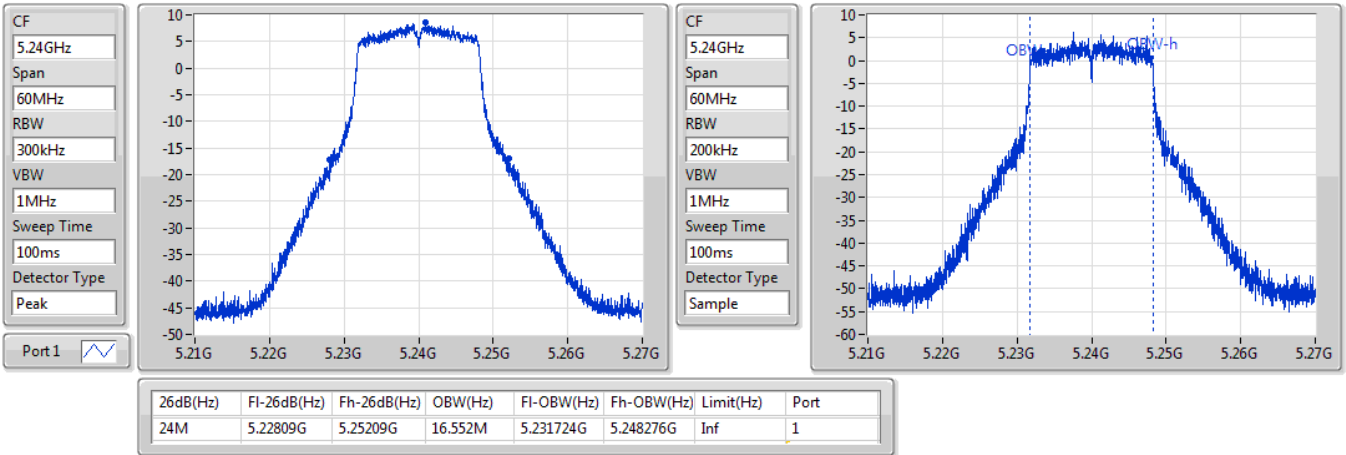

### 802.11a\_Nss1,(6Mbps)\_1TX

EBW

5260MHz

16/08/2019

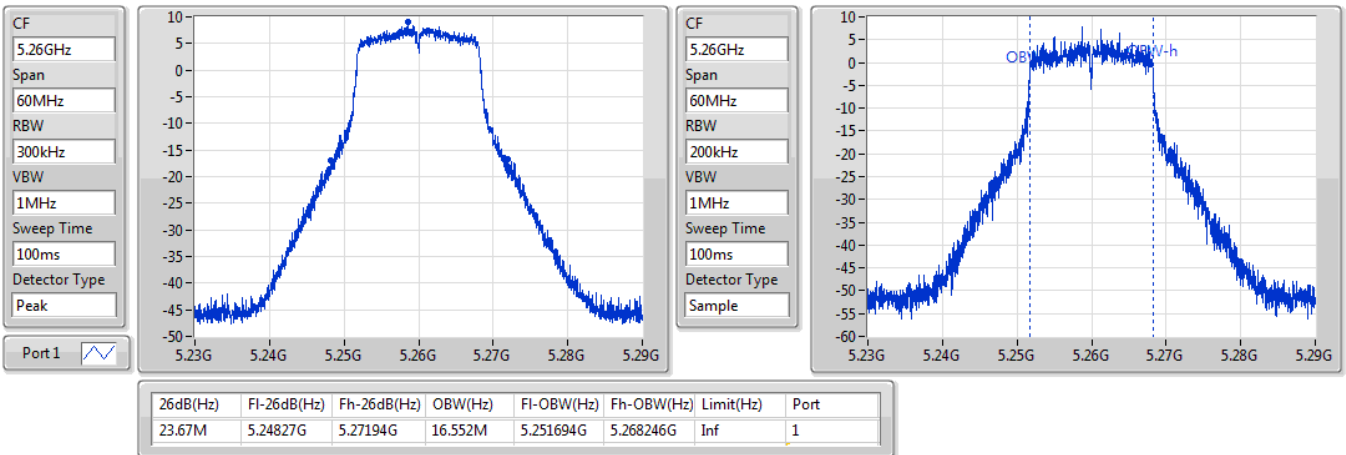



### 802.11a\_Nss1,(6Mbps)\_1TX

EBW

5300MHz

16/08/2019

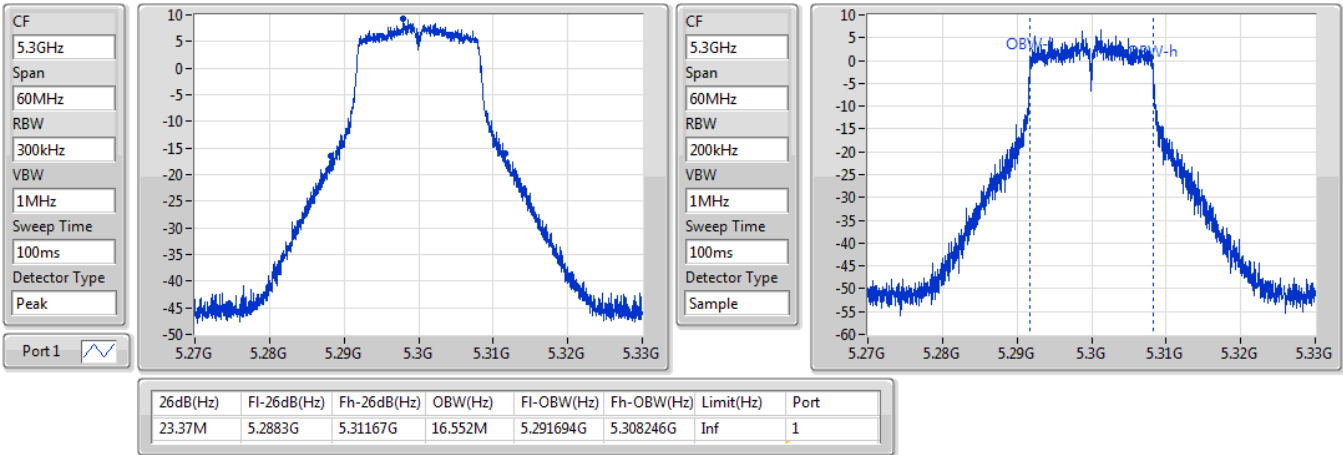

### 802.11a\_Nss1,(6Mbps)\_1TX

EBW

5320MHz

16/08/2019

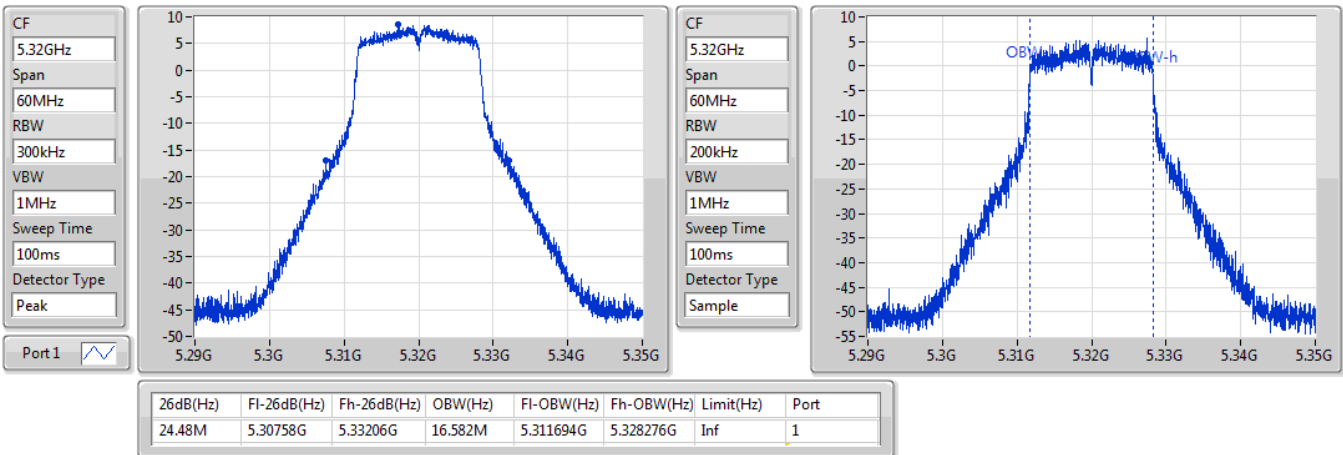

### 802.11a\_Nss1,(6Mbps)\_1TX

EBW

5500MHz

16/08/2019

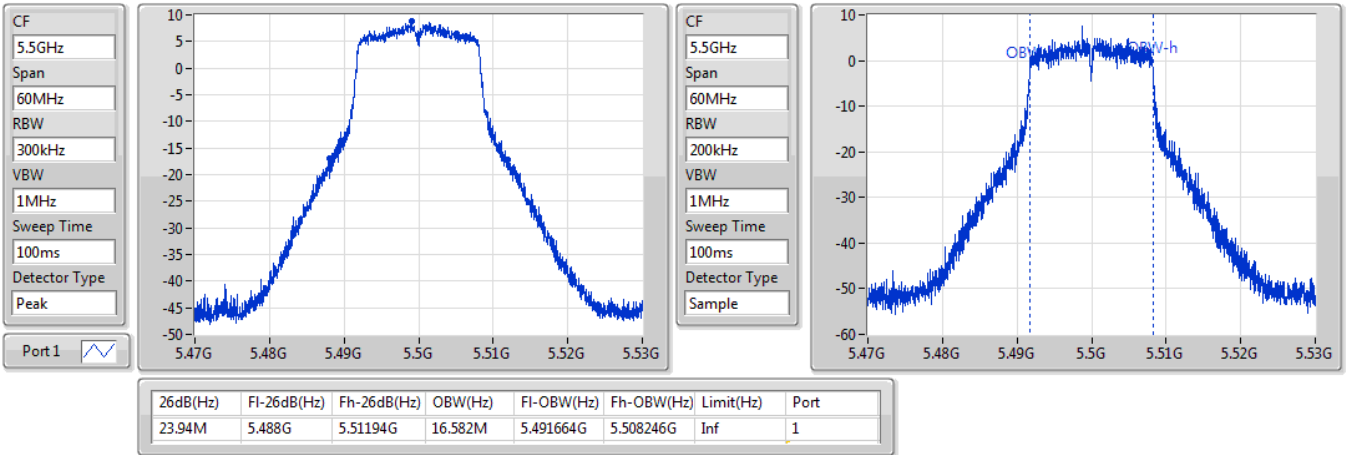

### 802.11a\_Nss1,(6Mbps)\_1TX

EBW

5580MHz

16/08/2019

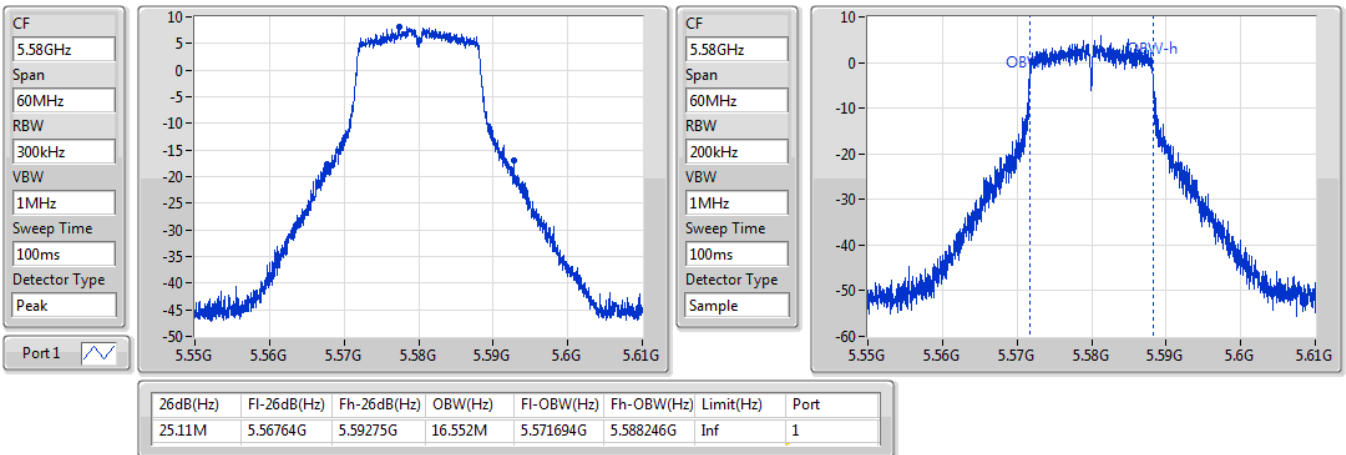

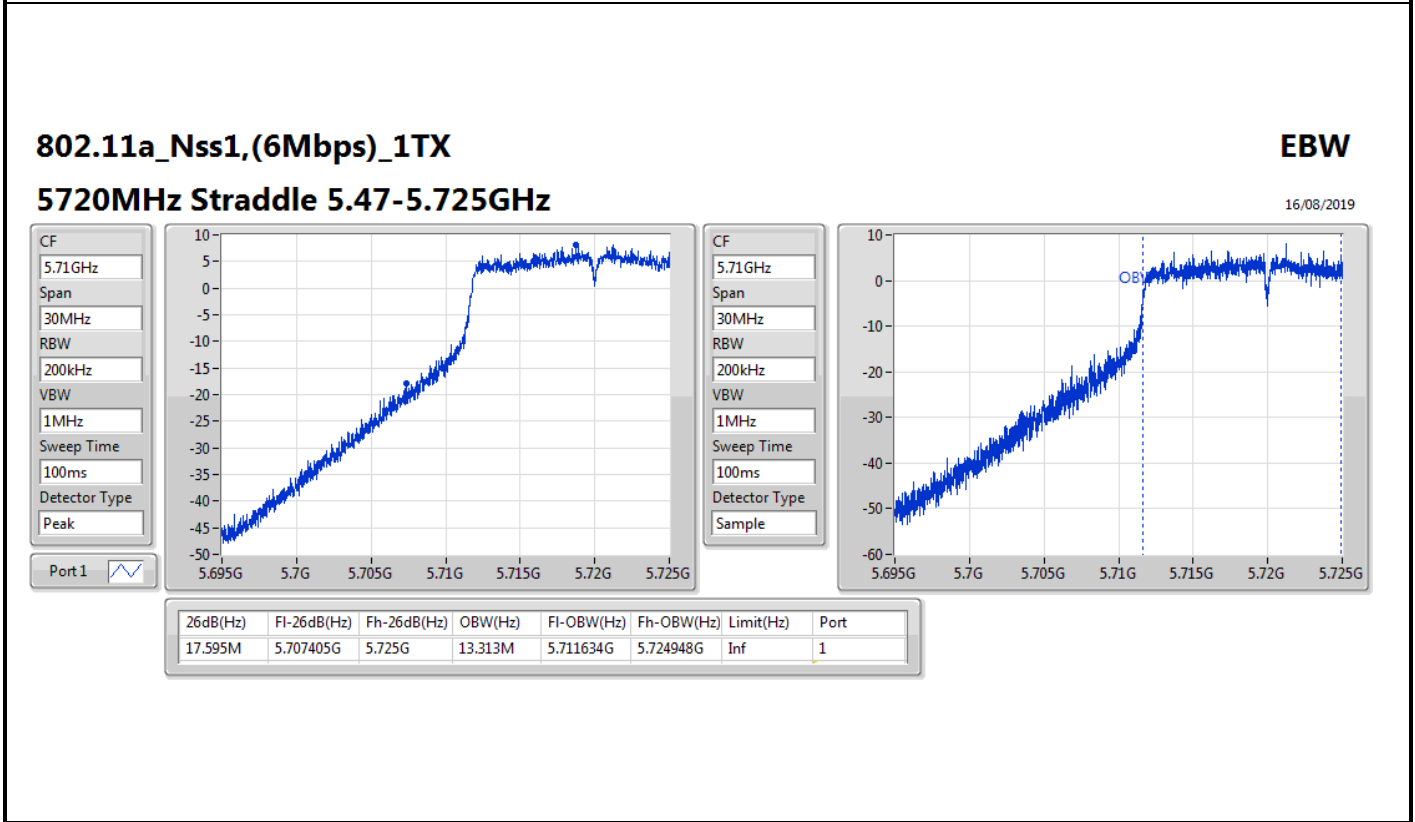
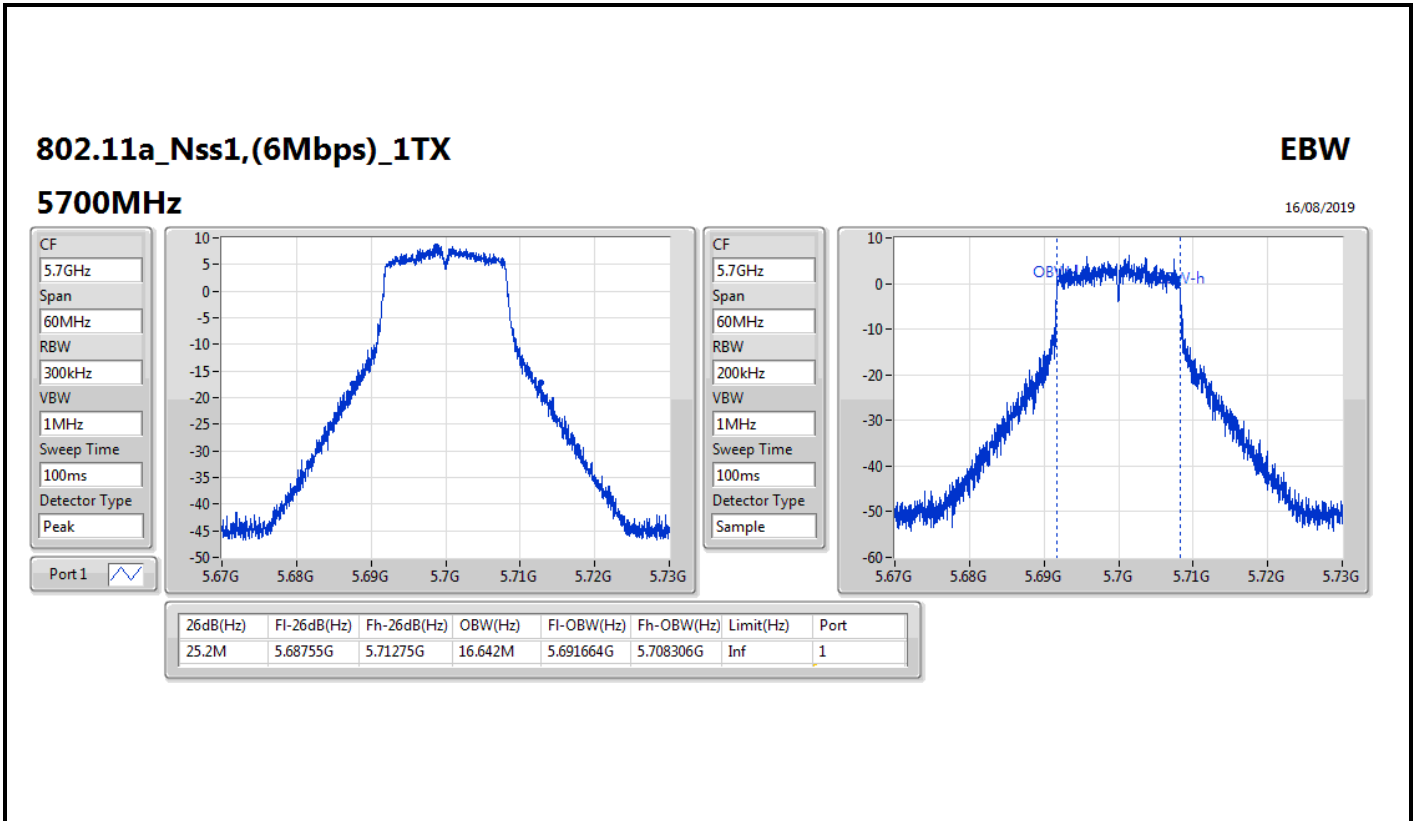

802.11a\_Nss1,(6Mbps)\_1TX

EBW

5720MHz Straddle 5.725-5.85GHz

16/08/2019

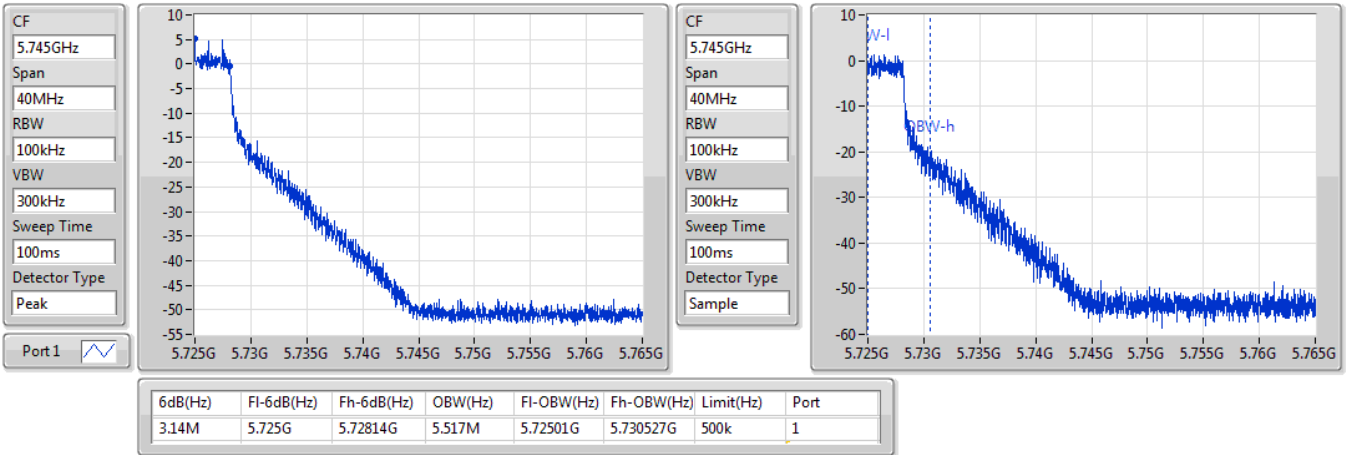

802.11a\_Nss1,(6Mbps)\_1TX

EBW

5745MHz

16/08/2019

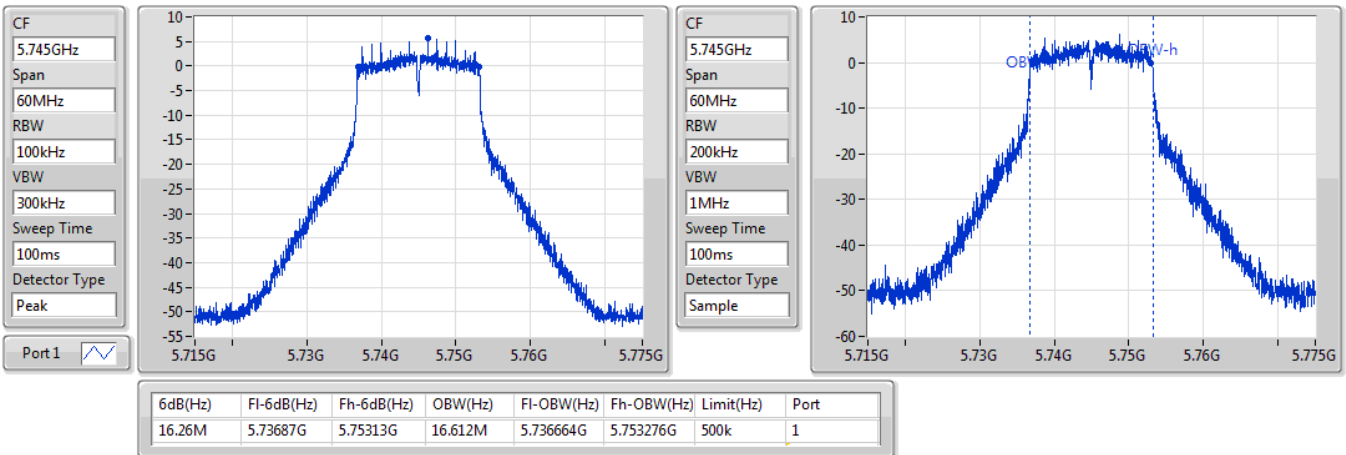

### 802.11a\_Nss1,(6Mbps)\_1TX

EBW

5785MHz

16/08/2019

CF: 5.785GHz  
 Span: 60MHz  
 RBW: 100kHz  
 VBW: 300kHz  
 Sweep Time: 100ms  
 Detector Type: Peak  
 Port 1

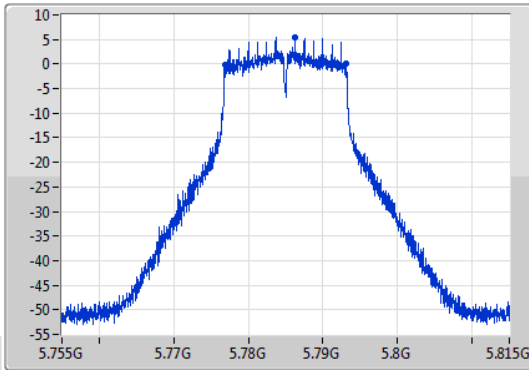

CF: 5.785GHz  
 Span: 60MHz  
 RBW: 200kHz  
 VBW: 1MHz  
 Sweep Time: 100ms  
 Detector Type: Sample

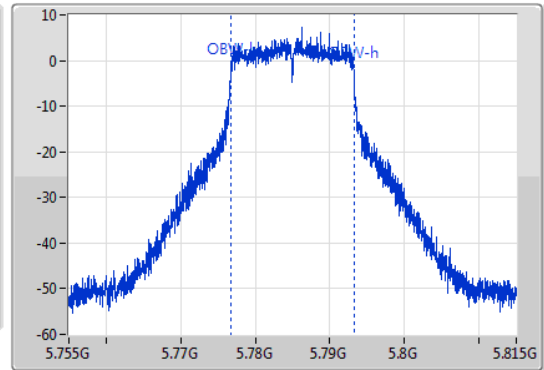

6dB(Hz)	Fl-6dB(Hz)	Fh-6dB(Hz)	OBW(Hz)	Fl-OBW(Hz)	Fh-OBW(Hz)	Limit(Hz)	Port
16.26M	5.77684G	5.7931G	16.552M	5.776694G	5.793246G	500k	1

### 802.11a\_Nss1,(6Mbps)\_1TX

EBW

5825MHz

16/08/2019

CF: 5.825GHz  
 Span: 60MHz  
 RBW: 100kHz  
 VBW: 300kHz  
 Sweep Time: 100ms  
 Detector Type: Peak  
 Port 1

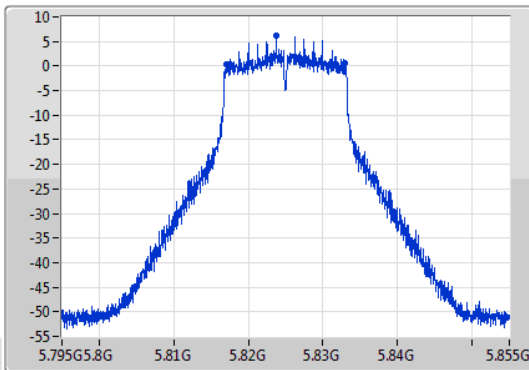

CF: 5.825GHz  
 Span: 60MHz  
 RBW: 200kHz  
 VBW: 1MHz  
 Sweep Time: 100ms  
 Detector Type: Sample

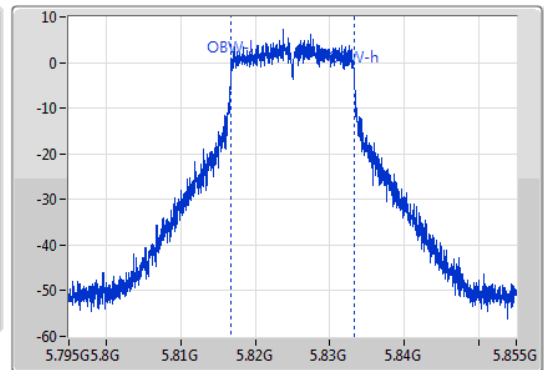

6dB(Hz)	Fl-6dB(Hz)	Fh-6dB(Hz)	OBW(Hz)	Fl-OBW(Hz)	Fh-OBW(Hz)	Limit(Hz)	Port
15.75M	5.81711G	5.83286G	16.552M	5.816694G	5.833246G	500k	1

802.11ac VHT20\_Nss1,(MCS0)\_1TX

EBW

5180MHz

16/08/2019

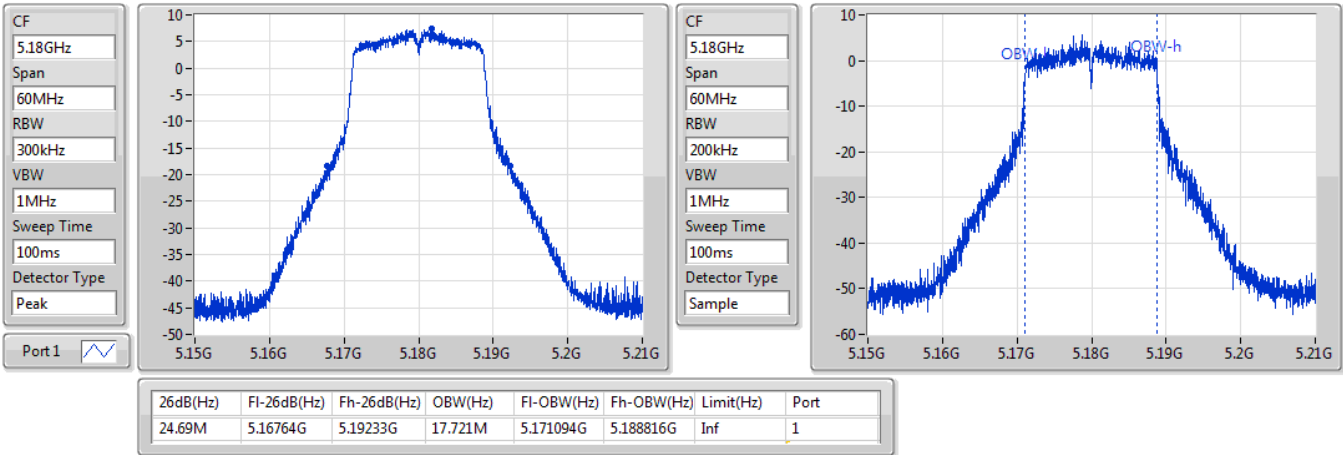

802.11ac VHT20\_Nss1,(MCS0)\_1TX

EBW

5200MHz

16/08/2019

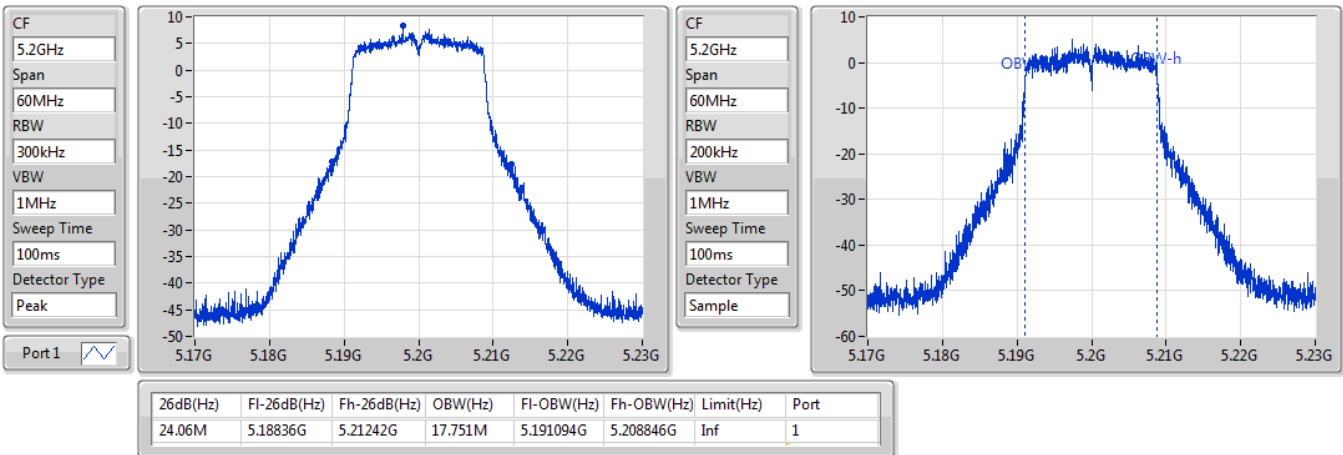

802.11ac VHT20\_Nss1,(MCS0)\_1TX

EBW

5240MHz

16/08/2019

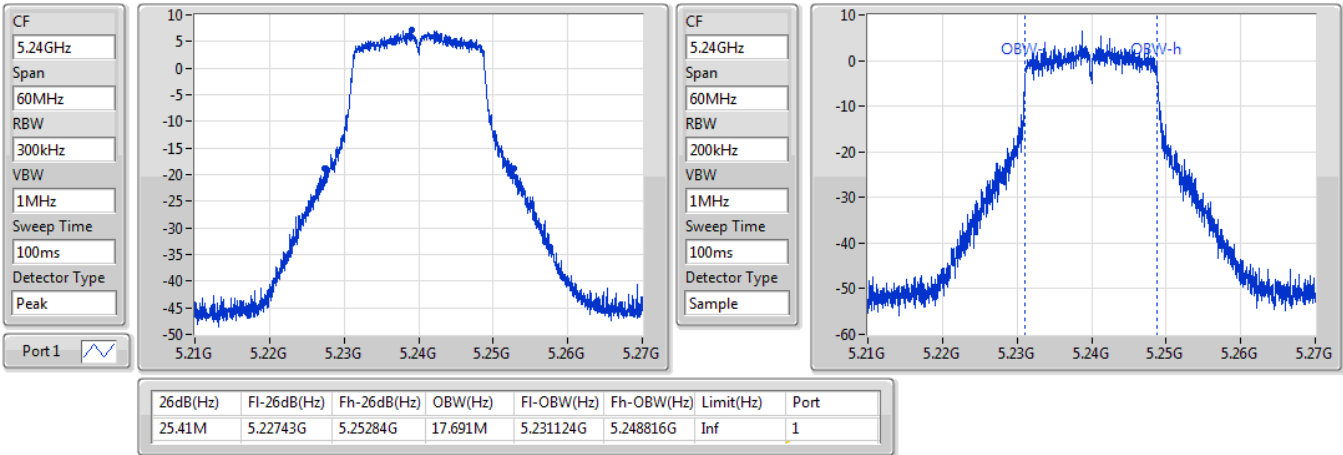

802.11ac VHT20\_Nss1,(MCS0)\_1TX

EBW

5260MHz

16/08/2019

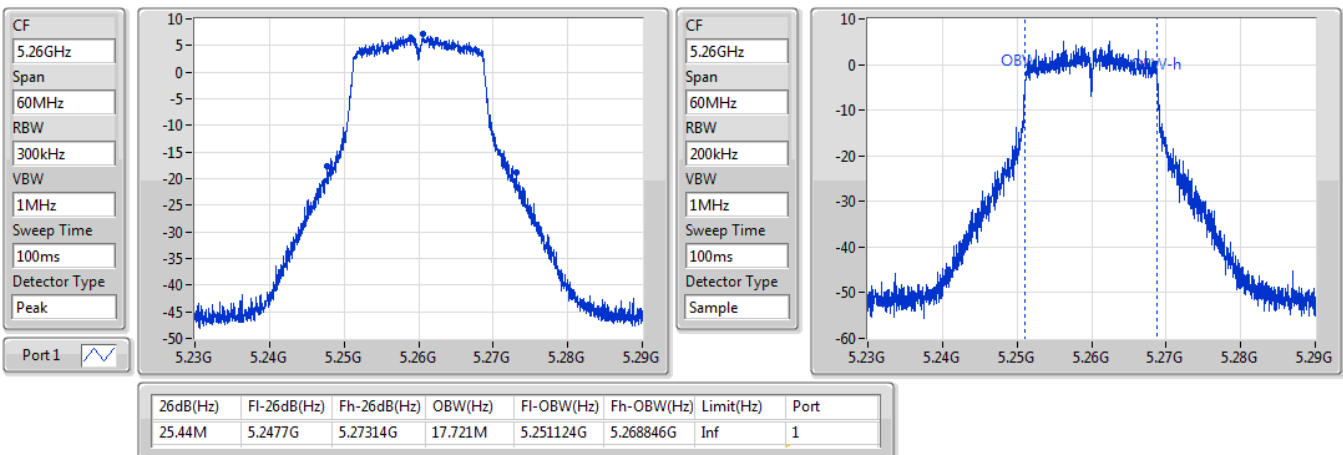

802.11ac VHT20\_Nss1,(MCS0)\_1TX

EBW

5300MHz

16/08/2019

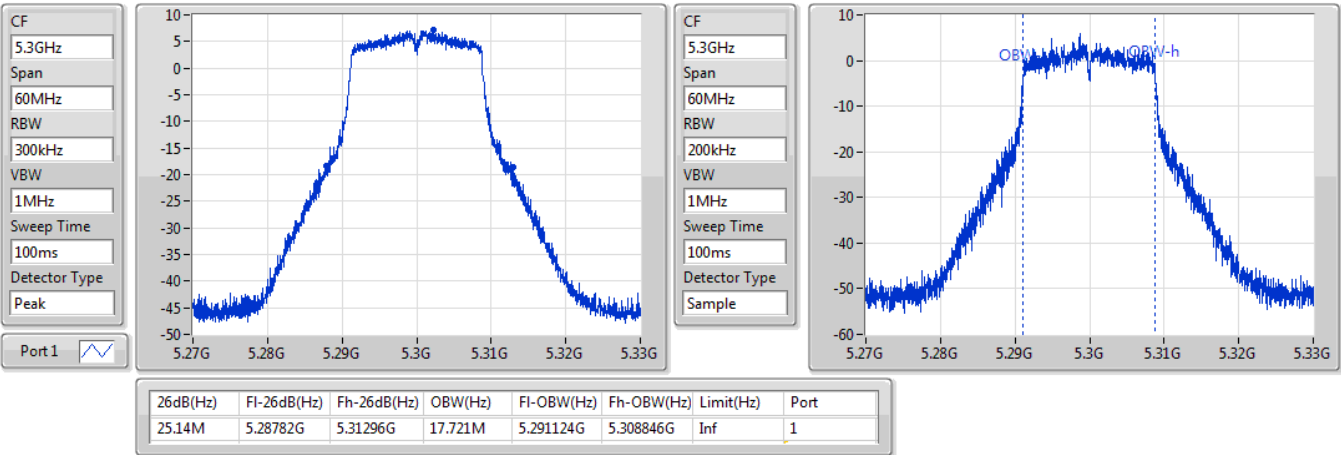

802.11ac VHT20\_Nss1,(MCS0)\_1TX

EBW

5320MHz

16/08/2019

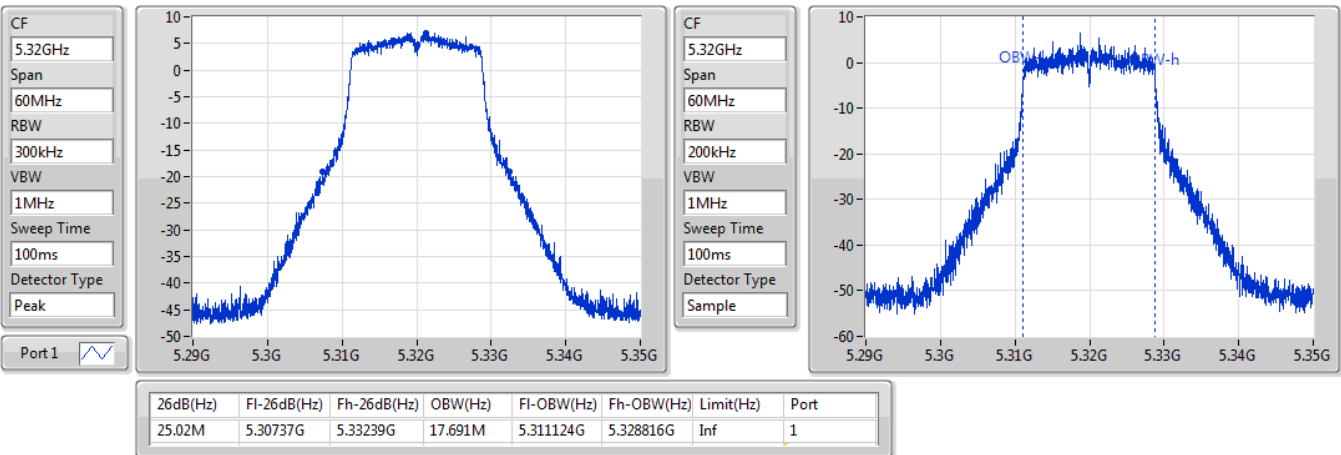



802.11ac VHT20\_Nss1,(MCS0)\_1TX

EBW

5500MHz

16/08/2019

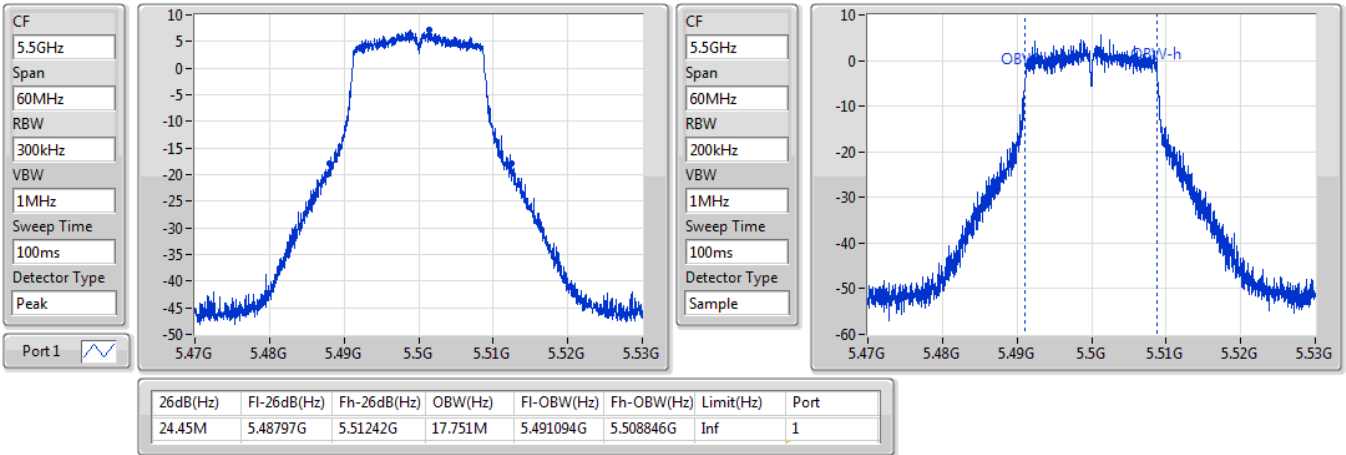

802.11ac VHT20\_Nss1,(MCS0)\_1TX

EBW

5580MHz

16/08/2019

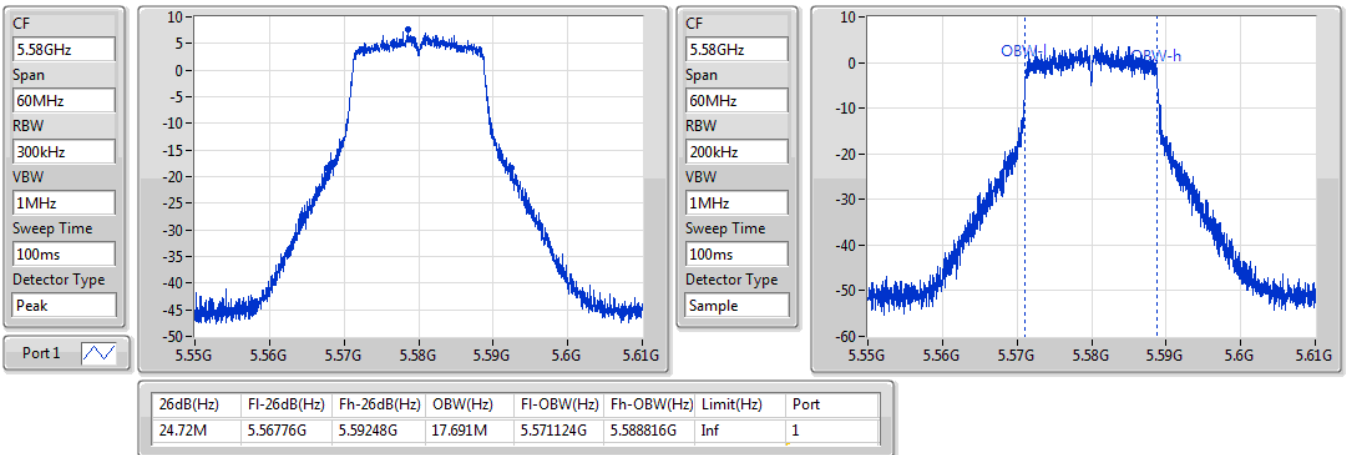

802.11ac VHT20\_Nss1,(MCS0)\_1TX

EBW

5700MHz

16/08/2019

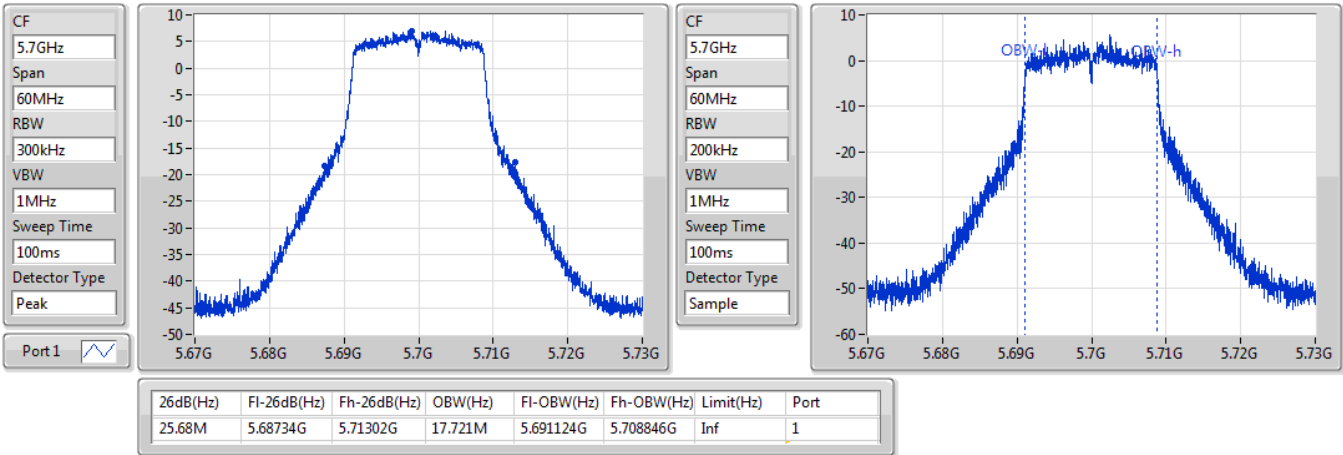

802.11ac VHT20\_Nss1,(MCS0)\_1TX

EBW

5720MHz Straddle 5.47-5.725GHz

16/08/2019

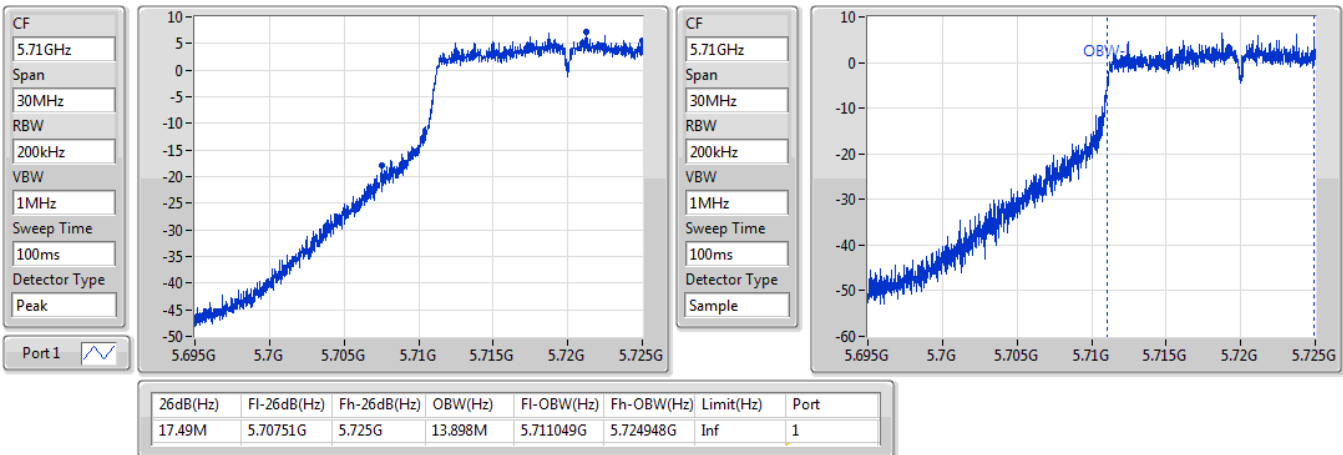

**802.11ac VHT20\_Nss1,(MCS0)\_1TX**  
**5720MHz Straddle 5.725-5.85GHz**

EBW

16/08/2019

CF  
5.745GHz  
Span  
40MHz  
RBW  
100kHz  
VBW  
300kHz  
Sweep Time  
100ms  
Detector Type  
Peak  
Port 1

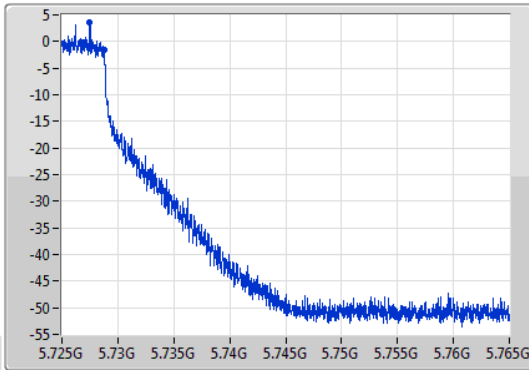

CF  
5.745GHz  
Span  
40MHz  
RBW  
50kHz  
VBW  
200kHz  
Sweep Time  
100ms  
Detector Type  
Sample

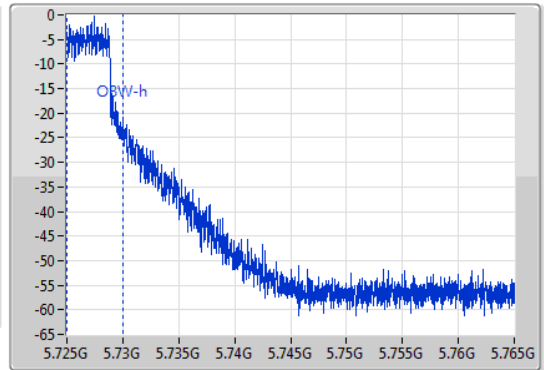

6dB(Hz)	Fl-6dB(Hz)	Fh-6dB(Hz)	OBW(Hz)	Fl-OBW(Hz)	Fh-OBW(Hz)	Limit(Hz)	Port
3.76M	5.725G	5.72876G	4.998M	5.72501G	5.730007G	500k	1

**802.11ac VHT20\_Nss1,(MCS0)\_1TX**  
**5745MHz**

EBW

16/08/2019

CF  
5.745GHz  
Span  
60MHz  
RBW  
100kHz  
VBW  
300kHz  
Sweep Time  
100ms  
Detector Type  
Peak  
Port 1

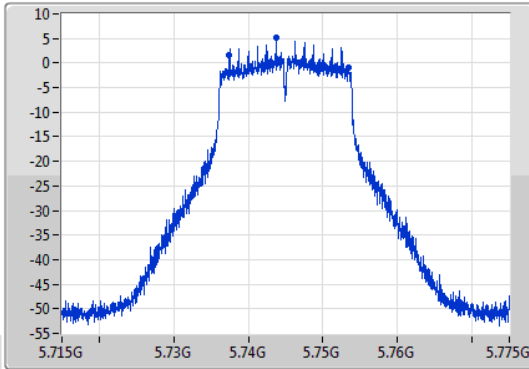

CF  
5.745GHz  
Span  
60MHz  
RBW  
200kHz  
VBW  
1MHz  
Sweep Time  
100ms  
Detector Type  
Sample

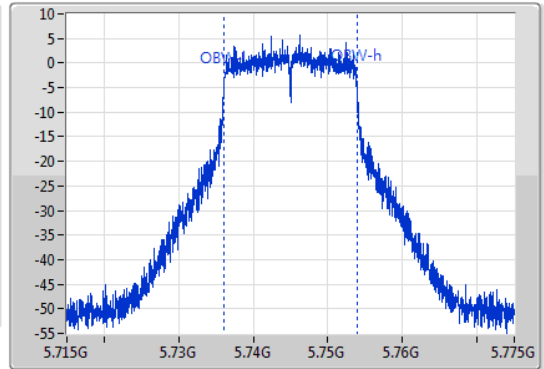

6dB(Hz)	Fl-6dB(Hz)	Fh-6dB(Hz)	OBW(Hz)	Fl-OBW(Hz)	Fh-OBW(Hz)	Limit(Hz)	Port
15.93M	5.73744G	5.75337G	17.781M	5.736094G	5.753876G	500k	1

802.11ac VHT20\_Nss1,(MCS0)\_1TX

EBW

5785MHz

16/08/2019

CF  
5.785GHz  
Span  
60MHz  
RBW  
100kHz  
VBW  
300kHz  
Sweep Time  
100ms  
Detector Type  
Peak  
Port 1

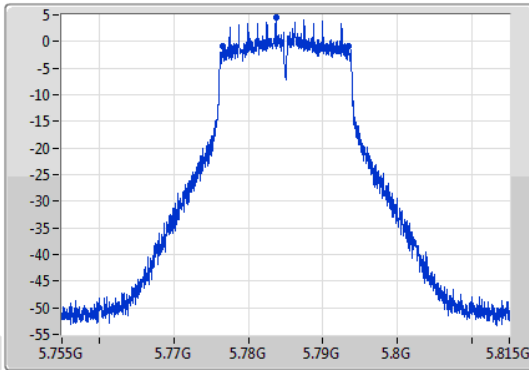

CF  
5.785GHz  
Span  
60MHz  
RBW  
200kHz  
VBW  
1MHz  
Sweep Time  
100ms  
Detector Type  
Sample

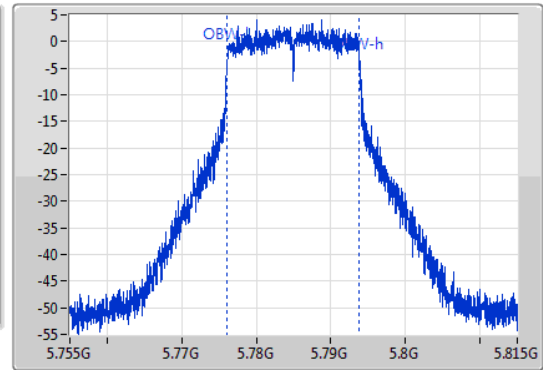

6dB(Hz)	Fl-6dB(Hz)	Fh-6dB(Hz)	OBW(Hz)	Fl-OBW(Hz)	Fh-OBW(Hz)	Limit(Hz)	Port
16.86M	5.77663G	5.79349G	17.751M	5.776094G	5.793846G	500k	1

802.11ac VHT20\_Nss1,(MCS0)\_1TX

EBW

5825MHz

16/08/2019

CF  
5.825GHz  
Span  
60MHz  
RBW  
100kHz  
VBW  
300kHz  
Sweep Time  
100ms  
Detector Type  
Peak  
Port 1

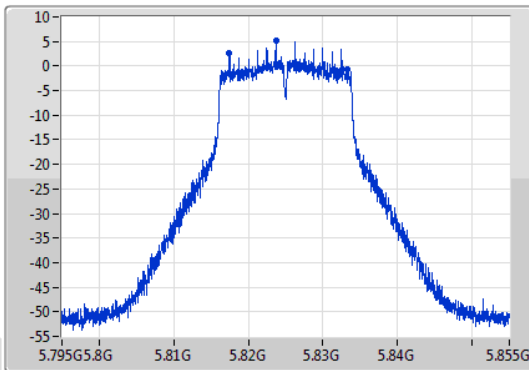

CF  
5.825GHz  
Span  
60MHz  
RBW  
200kHz  
VBW  
1MHz  
Sweep Time  
100ms  
Detector Type  
Sample

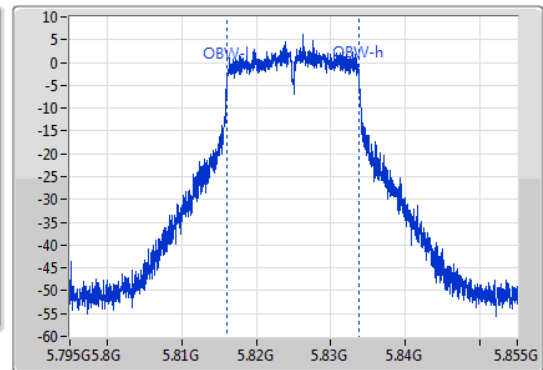

6dB(Hz)	Fl-6dB(Hz)	Fh-6dB(Hz)	OBW(Hz)	Fl-OBW(Hz)	Fh-OBW(Hz)	Limit(Hz)	Port
15.87M	5.81747G	5.83334G	17.691M	5.816094G	5.833786G	500k	1

802.11ac VHT40\_Nss1,(MCS0)\_1TX

EBW

5190MHz

16/08/2019

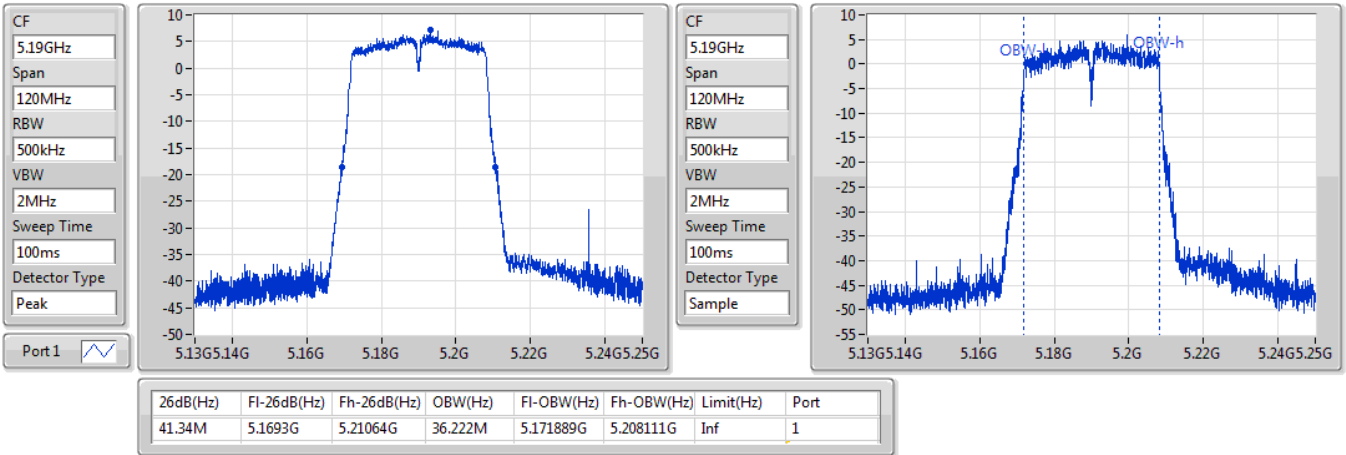

802.11ac VHT40\_Nss1,(MCS0)\_1TX

EBW

5230MHz

16/08/2019

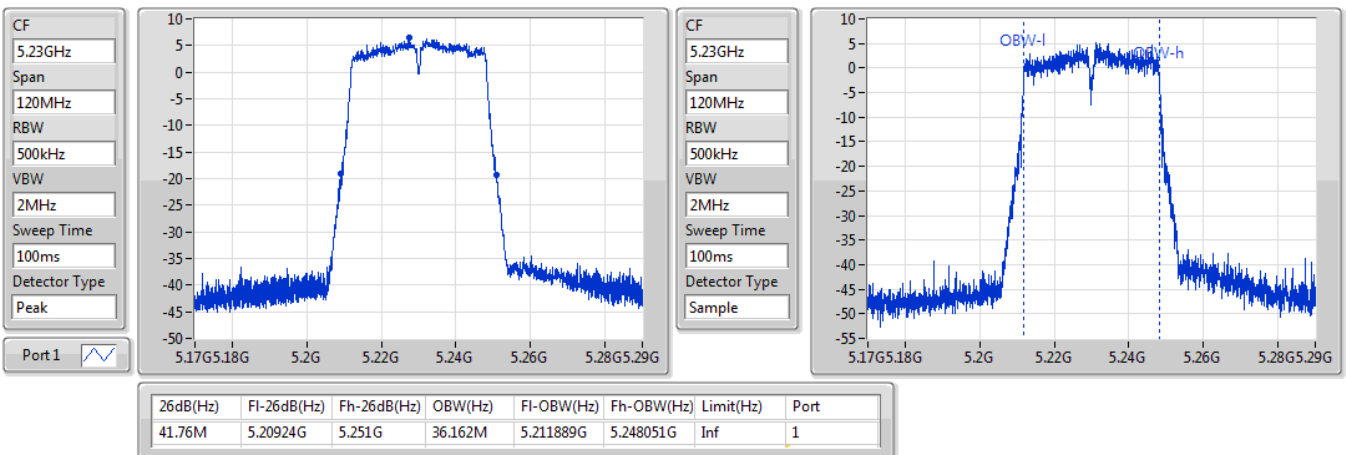

802.11ac VHT40\_Nss1,(MCS0)\_1TX

EBW

5270MHz

16/08/2019

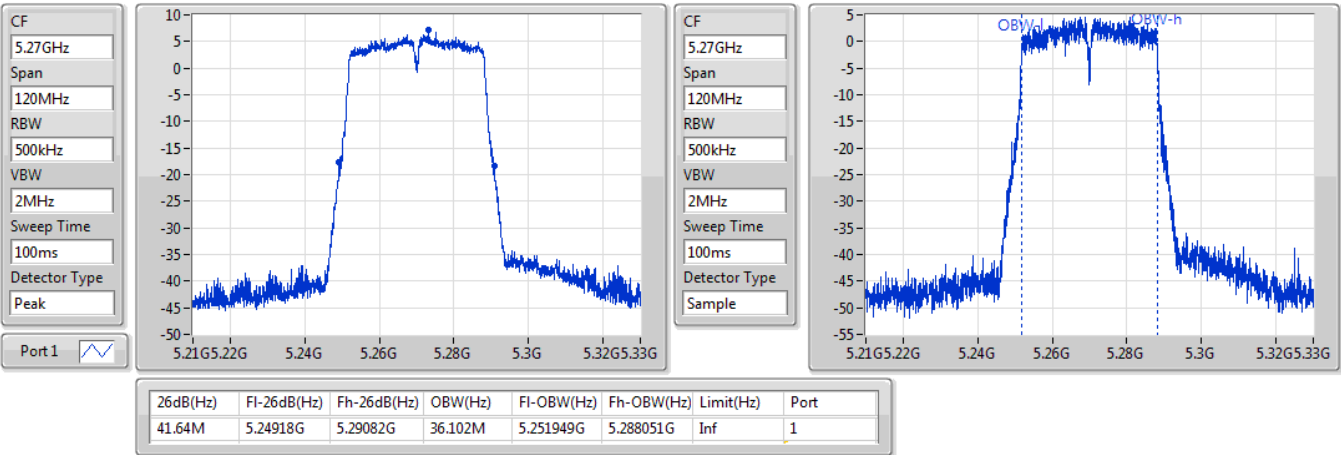

802.11ac VHT40\_Nss1,(MCS0)\_1TX

EBW

5310MHz

16/08/2019

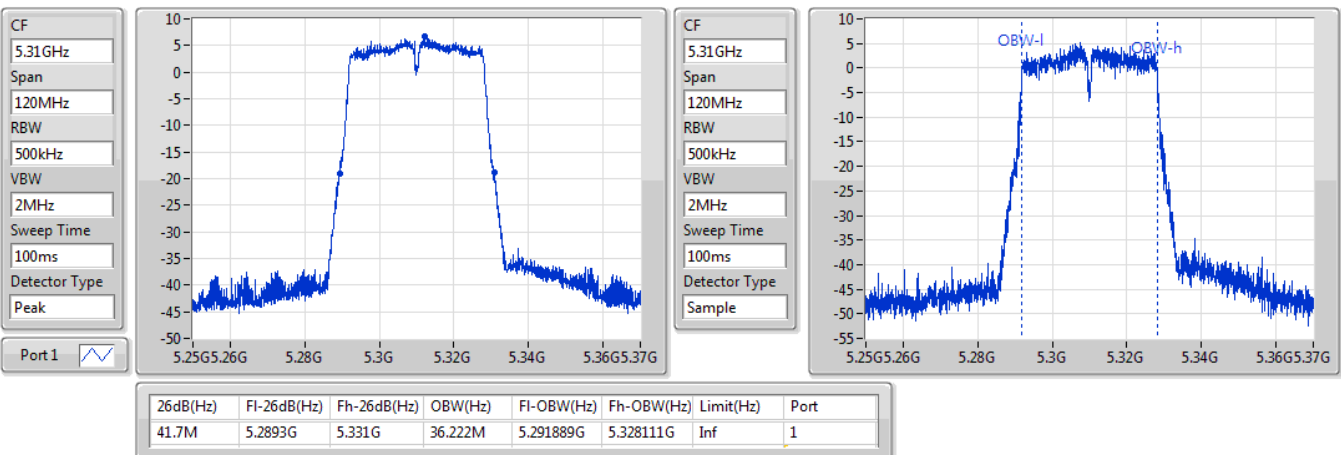

802.11ac VHT40\_Nss1,(MCS0)\_1TX

EBW

5510MHz

16/08/2019

CF  
5.51GHz  
Span  
120MHz  
RBW  
500kHz  
VBW  
2MHz  
Sweep Time  
100ms  
Detector Type  
Peak  
Port 1

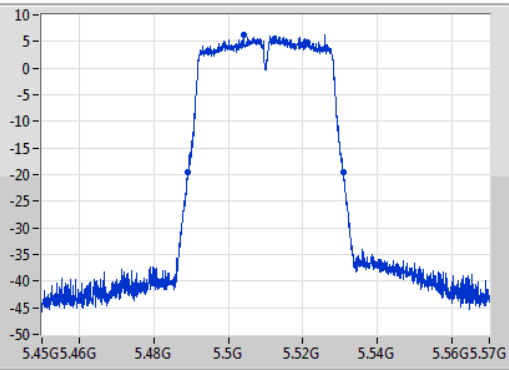

CF  
5.51GHz  
Span  
120MHz  
RBW  
500kHz  
VBW  
2MHz  
Sweep Time  
100ms  
Detector Type  
Sample

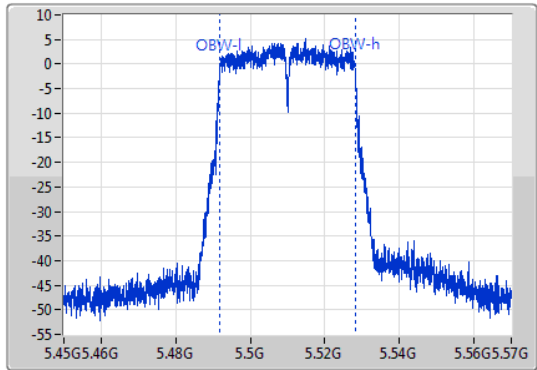

26dB(Hz)	Fl-26dB(Hz)	Fh-26dB(Hz)	OBW(Hz)	Fl-OBW(Hz)	Fh-OBW(Hz)	Limit(Hz)	Port
41.82M	5.48912G	5.53094G	36.222M	5.491829G	5.528051G	Inf	1

802.11ac VHT40\_Nss1,(MCS0)\_1TX

EBW

5550MHz

16/08/2019

CF  
5.55GHz  
Span  
120MHz  
RBW  
500kHz  
VBW  
2MHz  
Sweep Time  
100ms  
Detector Type  
Peak  
Port 1

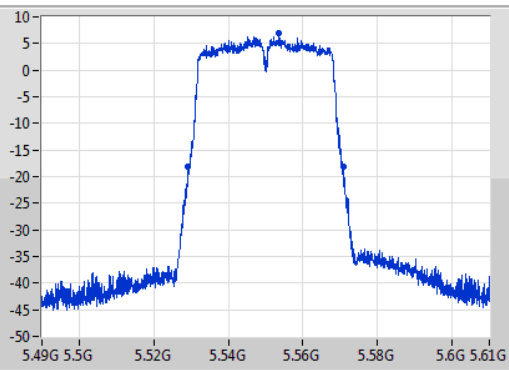

CF  
5.55GHz  
Span  
120MHz  
RBW  
500kHz  
VBW  
2MHz  
Sweep Time  
100ms  
Detector Type  
Sample

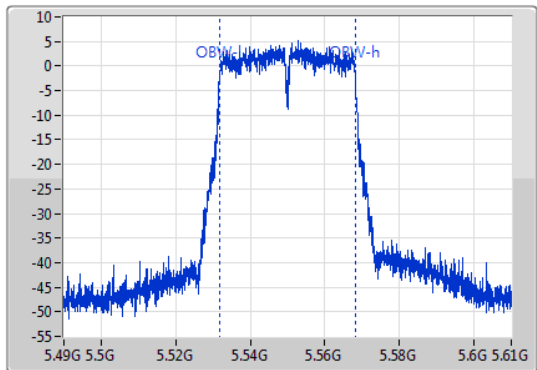

26dB(Hz)	Fl-26dB(Hz)	Fh-26dB(Hz)	OBW(Hz)	Fl-OBW(Hz)	Fh-OBW(Hz)	Limit(Hz)	Port
41.76M	5.52924G	5.571G	36.222M	5.531829G	5.568051G	Inf	1

802.11ac VHT40\_Nss1,(MCS0)\_1TX

EBW

5670MHz

16/08/2019

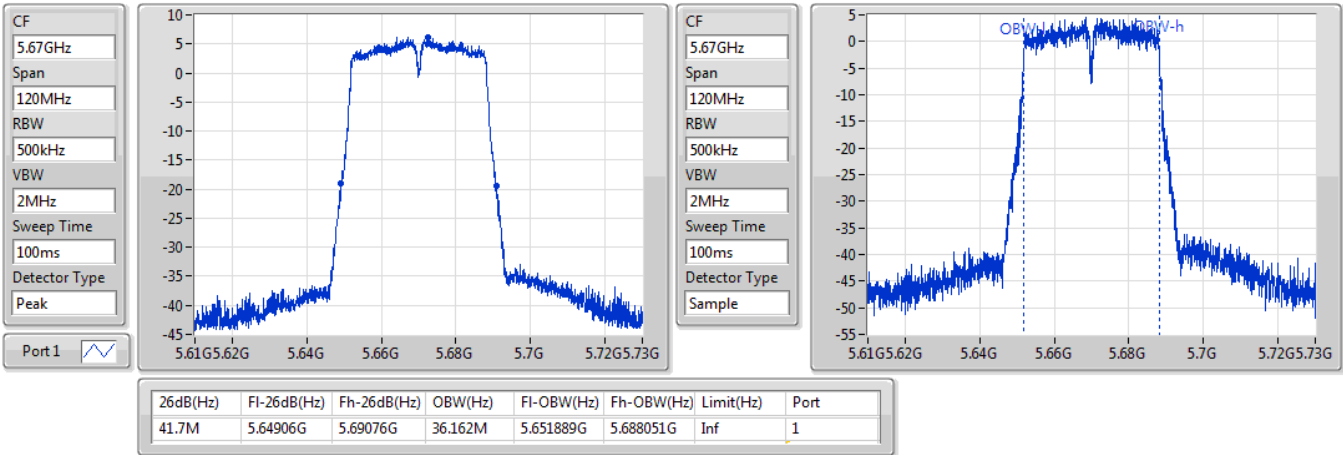

802.11ac VHT40\_Nss1,(MCS0)\_1TX

EBW

5710MHz Straddle 5.47-5.725GHz

16/08/2019

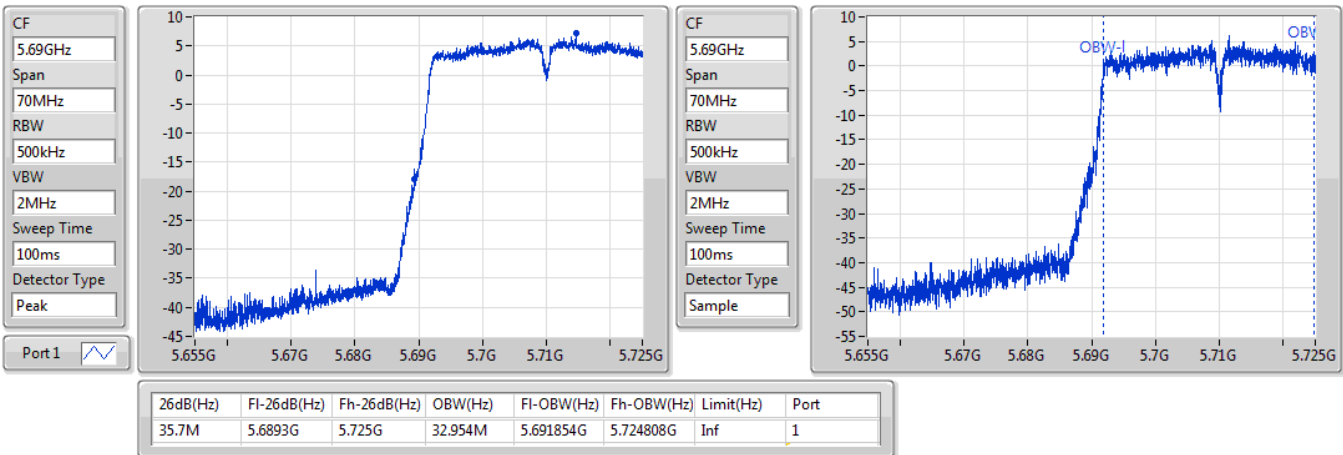



**802.11ac VHT40\_Nss1,(MCS0)\_1TX**  
**5710MHz Straddle 5.725-5.85GHz**

EBW

16/08/2019

CF  
5.745GHz  
Span  
40MHz  
RBW  
100kHz  
VBW  
300kHz  
Sweep Time  
100ms  
Detector Type  
Peak  
Port 1

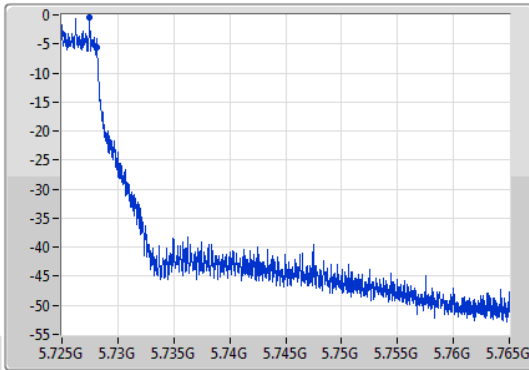

CF  
5.745GHz  
Span  
40MHz  
RBW  
50kHz  
VBW  
200kHz  
Sweep Time  
100ms  
Detector Type  
Sample

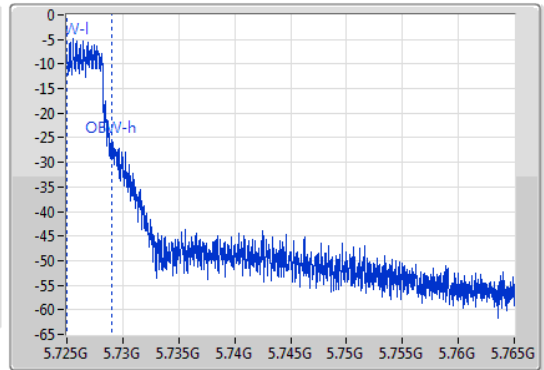

6dB(Hz)	Fl-6dB(Hz)	Fh-6dB(Hz)	OBW(Hz)	Fl-OBW(Hz)	Fh-OBW(Hz)	Limit(Hz)	Port
3.14M	5.725G	5.72814G	3.998M	5.72501G	5.729008G	500k	1

**802.11ac VHT40\_Nss1,(MCS0)\_1TX**  
**5755MHz**

EBW

16/08/2019

CF  
5.755GHz  
Span  
120MHz  
RBW  
100kHz  
VBW  
300kHz  
Sweep Time  
100ms  
Detector Type  
Peak  
Port 1

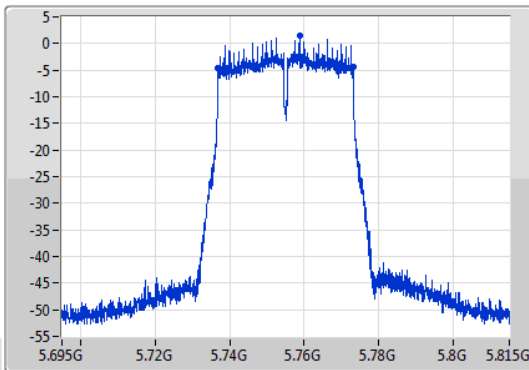

CF  
5.755GHz  
Span  
120MHz  
RBW  
500kHz  
VBW  
2MHz  
Sweep Time  
100ms  
Detector Type  
Sample

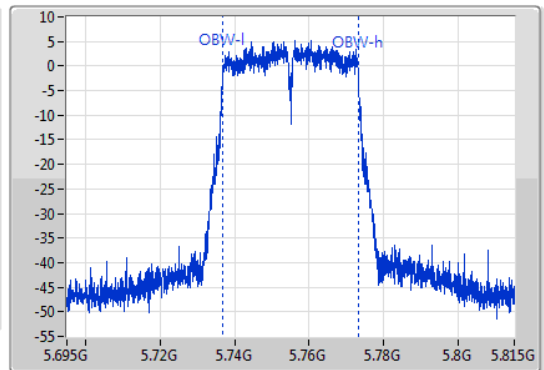

6dB(Hz)	Fl-6dB(Hz)	Fh-6dB(Hz)	OBW(Hz)	Fl-OBW(Hz)	Fh-OBW(Hz)	Limit(Hz)	Port
36.24M	5.73688G	5.77312G	36.162M	5.736889G	5.773051G	500k	1

### 802.11ac VHT40\_Nss1,(MCS0)\_1TX

EBW

5795MHz

16/08/2019

CF  
5.795GHz  
Span  
120MHz  
RBW  
100kHz  
VBW  
300kHz  
Sweep Time  
100ms  
Detector Type  
Peak  
Port 1

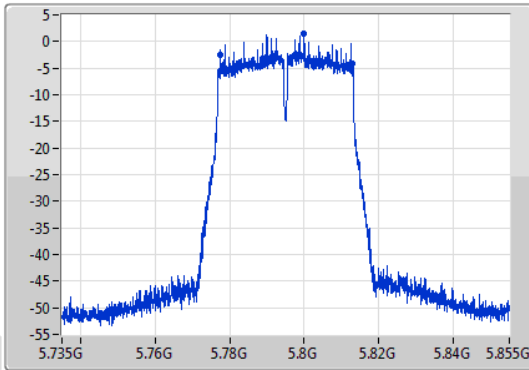

CF  
5.795GHz  
Span  
120MHz  
RBW  
500kHz  
VBW  
2MHz  
Sweep Time  
100ms  
Detector Type  
Sample

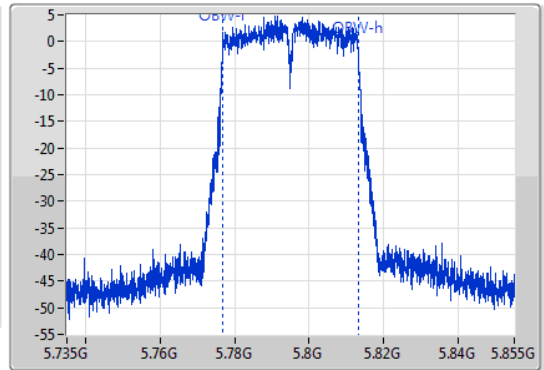

6dB(Hz)	Fl-6dB(Hz)	Fh-6dB(Hz)	OBW(Hz)	Fl-OBW(Hz)	Fh-OBW(Hz)	Limit(Hz)	Port
35.34M	5.77742G	5.81276G	36.222M	5.776829G	5.813051G	500k	1

### 802.11ac VHT80\_Nss1,(MCS0)\_1TX

EBW

5210MHz

16/08/2019

CF  
5.21GHz  
Span  
240MHz  
RBW  
1MHz  
VBW  
3MHz  
Sweep Time  
100ms  
Detector Type  
Peak  
Port 1

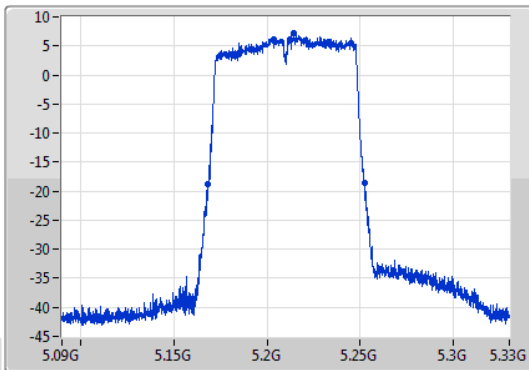

CF  
5.21GHz  
Span  
240MHz  
RBW  
1MHz  
VBW  
3MHz  
Sweep Time  
100ms  
Detector Type  
Sample

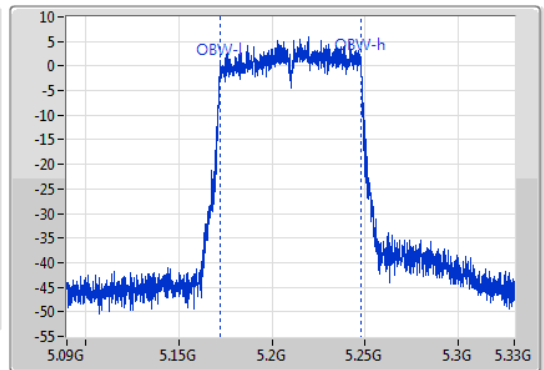

26dB(Hz)	Fl-26dB(Hz)	Fh-26dB(Hz)	OBW(Hz)	Fl-OBW(Hz)	Fh-OBW(Hz)	Limit(Hz)	Port
84.12M	5.16836G	5.25248G	75.562M	5.172219G	5.247781G	Inf	1

### 802.11ac VHT80\_Nss1,(MCS0)\_1TX

EBW

5290MHz

16/08/2019

CF  
5.29GHz  
Span  
240MHz  
RBW  
1MHz  
VBW  
3MHz  
Sweep Time  
100ms  
Detector Type  
Peak  
Port 1

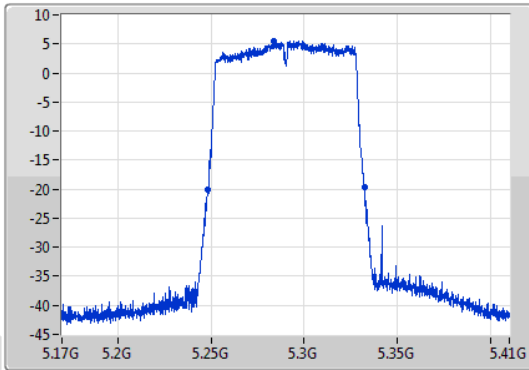

CF  
5.29GHz  
Span  
240MHz  
RBW  
1MHz  
VBW  
3MHz  
Sweep Time  
100ms  
Detector Type  
Sample

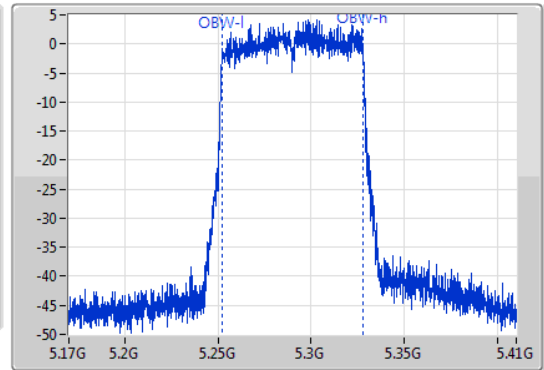

26dB(Hz)	Fl-26dB(Hz)	Fh-26dB(Hz)	OBW(Hz)	Fl-OBW(Hz)	Fh-OBW(Hz)	Limit(Hz)	Port
84.24M	5.248G	5.33224G	75.562M	5.252219G	5.327781G	Inf	1

### 802.11ac VHT80\_Nss1,(MCS0)\_1TX

EBW

5530MHz

16/08/2019

CF  
5.53GHz  
Span  
240MHz  
RBW  
1MHz  
VBW  
3MHz  
Sweep Time  
100ms  
Detector Type  
Peak  
Port 1

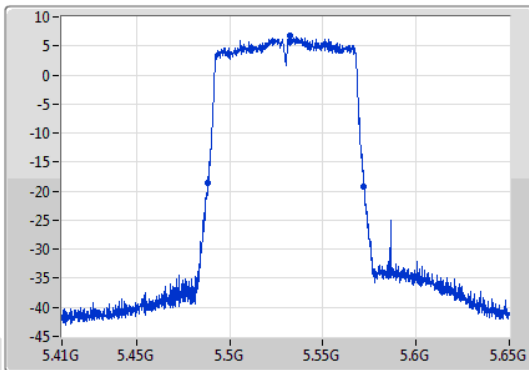

CF  
5.53GHz  
Span  
240MHz  
RBW  
1MHz  
VBW  
3MHz  
Sweep Time  
100ms  
Detector Type  
Sample

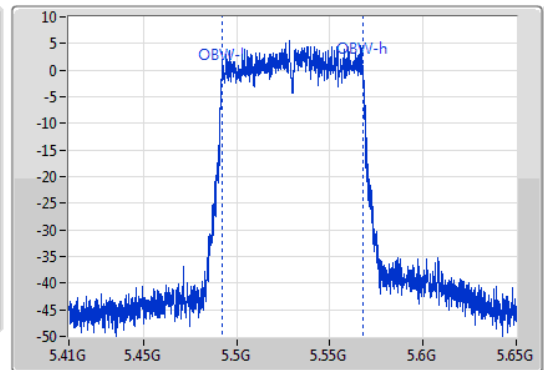

26dB(Hz)	Fl-26dB(Hz)	Fh-26dB(Hz)	OBW(Hz)	Fl-OBW(Hz)	Fh-OBW(Hz)	Limit(Hz)	Port
83.64M	5.48824G	5.57188G	75.802M	5.492099G	5.567901G	Inf	1

**802.11ac VHT80\_Nss1,(MCS0)\_1TX**  
**5690MHz Straddle 5.47-5.725GHz**

EBW

16/08/2019

CF: 5.65GHz  
 Span: 150MHz  
 RBW: 1MHz  
 VBW: 3MHz  
 Sweep Time: 100ms  
 Detector Type: Peak

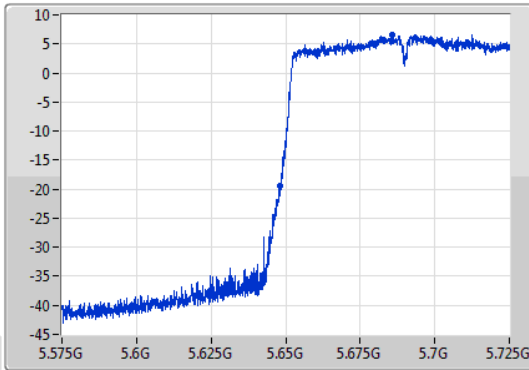

CF: 5.65GHz  
 Span: 150MHz  
 RBW: 1MHz  
 VBW: 3MHz  
 Sweep Time: 100ms  
 Detector Type: Sample

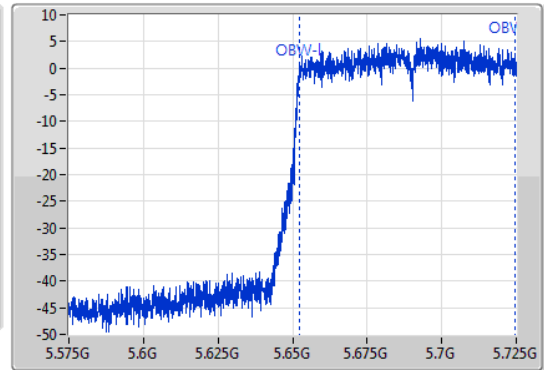

26dB(Hz)	Fl-26dB(Hz)	Fh-26dB(Hz)	OBW(Hz)	Fl-OBW(Hz)	Fh-OBW(Hz)	Limit(Hz)	Port
76.95M	5.64805G	5.725G	72.414M	5.652174G	5.724588G	Inf	1

**802.11ac VHT80\_Nss1,(MCS0)\_1TX**  
**5690MHz Straddle 5.725-5.85GHz**

EBW

16/08/2019

CF: 5.745GHz  
 Span: 40MHz  
 RBW: 100kHz  
 VBW: 300kHz  
 Sweep Time: 100ms  
 Detector Type: Peak

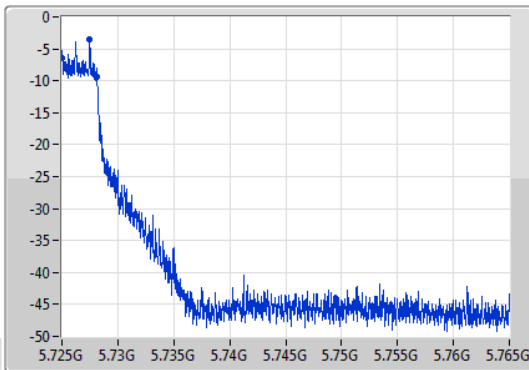

CF: 5.745GHz  
 Span: 40MHz  
 RBW: 50kHz  
 VBW: 200kHz  
 Sweep Time: 100ms  
 Detector Type: Sample

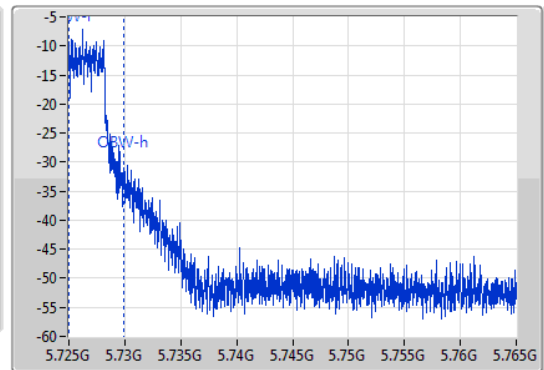

6dB(Hz)	Fl-6dB(Hz)	Fh-6dB(Hz)	OBW(Hz)	Fl-OBW(Hz)	Fh-OBW(Hz)	Limit(Hz)	Port
3.14M	5.725G	5.72814G	4.938M	5.72501G	5.729948G	500k	1

### 802.11ac VHT80\_Nss1,(MCS0)\_1TX

EBW

5775MHz

16/08/2019

CF  
5.775GHz  
Span  
240MHz  
RBW  
100kHz  
VBW  
300kHz  
Sweep Time  
100ms  
Detector Type  
Peak  
Port 1

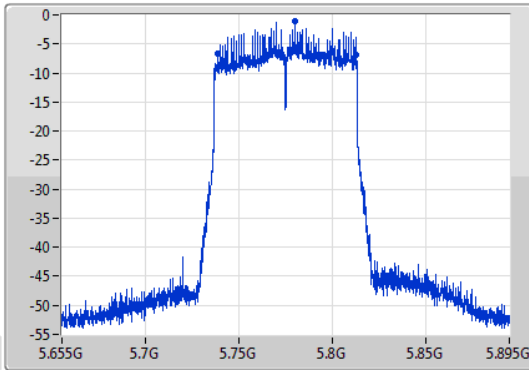

CF  
5.775GHz  
Span  
240MHz  
RBW  
1MHz  
VBW  
3MHz  
Sweep Time  
100ms  
Detector Type  
Sample

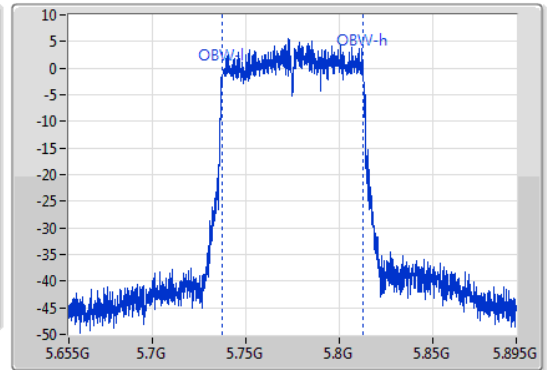

6dB(Hz)	Fl-6dB(Hz)	Fh-6dB(Hz)	OBW(Hz)	Fl-OBW(Hz)	Fh-OBW(Hz)	Limit(Hz)	Port
73.92M	5.73864G	5.81256G	75.682M	5.737219G	5.812901G	500k	1



**Summary**

Mode	Total Power (dBm)	Total Power (W)	EIRP (dBm)	EIRP (W)
5.15-5.25GHz	-	-	-	-
802.11a_Nss1,(6Mbps)_1TX	16.40	0.04365	20.56	0.11376
802.11ac VHT20_Nss1,(MCS0)_1TX	15.44	0.03499	19.60	0.09120
802.11ac VHT40_Nss1,(MCS0)_1TX	15.33	0.03412	19.49	0.08892
802.11ac VHT80_Nss1,(MCS0)_1TX	14.95	0.03126	19.11	0.08147
5.25-5.35GHz	-	-	-	-
802.11a_Nss1,(6Mbps)_1TX	16.47	0.04436	20.63	0.11561
802.11ac VHT20_Nss1,(MCS0)_1TX	15.30	0.03388	19.46	0.08831
802.11ac VHT40_Nss1,(MCS0)_1TX	15.31	0.03396	19.47	0.08851
802.11ac VHT80_Nss1,(MCS0)_1TX	13.86	0.02432	18.02	0.06339
5.47-5.725GHz	-	-	-	-
802.11a_Nss1,(6Mbps)_1TX	16.48	0.04446	20.64	0.11588
802.11ac VHT20_Nss1,(MCS0)_1TX	15.36	0.03436	19.52	0.08954
802.11ac VHT40_Nss1,(MCS0)_1TX	15.21	0.03319	19.37	0.08650
802.11ac VHT80_Nss1,(MCS0)_1TX	14.92	0.03105	19.08	0.08091
5.725-5.85GHz	-	-	-	-
802.11a_Nss1,(6Mbps)_1TX	16.35	0.04315	20.51	0.11246
802.11ac VHT20_Nss1,(MCS0)_1TX	15.30	0.03388	19.46	0.08831
802.11ac VHT40_Nss1,(MCS0)_1TX	15.15	0.03273	19.31	0.08531
802.11ac VHT80_Nss1,(MCS0)_1TX	14.57	0.02864	18.73	0.07464



Result

Mode	Result	DG (dBi)	Port 1 (dBm)	Total Power (dBm)	Power Limit (dBm)	EIRP (dBm)	EIRP Limit (dBm)
802.11a_Nss1,(6Mbps)_1TX	-	-	-	-	-	-	-
5180MHz_TnomVnom	Pass	4.16	16.10	16.10	23.98	20.26	30.00
5200MHz_TnomVnom	Pass	4.16	16.05	16.05	23.98	20.21	30.00
5240MHz_TnomVnom	Pass	4.16	16.40	16.40	23.98	20.56	30.00
5260MHz_TnomVnom	Pass	4.16	16.39	16.39	23.98	20.55	30.00
5300MHz_TnomVnom	Pass	4.16	16.47	16.47	23.98	20.63	30.00
5320MHz_TnomVnom	Pass	4.16	16.39	16.39	23.98	20.55	30.00
5500MHz_TnomVnom	Pass	4.16	16.48	16.48	23.98	20.64	30.00
5580MHz_TnomVnom	Pass	4.16	16.28	16.28	23.98	20.44	30.00
5700MHz_TnomVnom	Pass	4.16	16.48	16.48	23.98	20.64	30.00
5720MHz Straddle 5.47-5.725GHz_TnomVnom	Pass	4.16	16.16	16.16	23.45	20.32	29.45
5720MHz Straddle 5.725-5.85GHz_TnomVnom	Pass	4.16	9.47	9.47	30.00	13.63	36.00
5745MHz_TnomVnom	Pass	4.16	16.32	16.32	30.00	20.48	36.00
5785MHz_TnomVnom	Pass	4.16	16.35	16.35	30.00	20.51	36.00
5825MHz_TnomVnom	Pass	4.16	16.34	16.34	30.00	20.50	36.00
802.11ac VHT20_Nss1,(MCS0)_1TX	-	-	-	-	-	-	-
5180MHz_TnomVnom	Pass	4.16	15.44	15.44	23.98	19.60	30.00
5200MHz_TnomVnom	Pass	4.16	15.42	15.42	23.98	19.58	30.00
5240MHz_TnomVnom	Pass	4.16	15.28	15.28	23.98	19.44	30.00
5260MHz_TnomVnom	Pass	4.16	15.29	15.29	23.98	19.45	30.00
5300MHz_TnomVnom	Pass	4.16	15.24	15.24	23.98	19.40	30.00
5320MHz_TnomVnom	Pass	4.16	15.30	15.30	23.98	19.46	30.00
5500MHz_TnomVnom	Pass	4.16	15.27	15.27	23.98	19.43	30.00
5580MHz_TnomVnom	Pass	4.16	15.14	15.14	23.98	19.30	30.00
5700MHz_TnomVnom	Pass	4.16	15.36	15.36	23.98	19.52	30.00
5720MHz Straddle 5.47-5.725GHz_TnomVnom	Pass	4.16	15.13	15.13	23.43	19.29	29.43
5720MHz Straddle 5.725-5.85GHz_TnomVnom	Pass	4.16	8.82	8.82	30.00	12.98	36.00
5745MHz_TnomVnom	Pass	4.16	15.30	15.30	30.00	19.46	36.00
5785MHz_TnomVnom	Pass	4.16	15.23	15.23	30.00	19.39	36.00
5825MHz_TnomVnom	Pass	4.16	15.29	15.29	30.00	19.45	36.00
802.11ac VHT40_Nss1,(MCS0)_1TX	-	-	-	-	-	-	-
5190MHz_TnomVnom	Pass	4.16	15.33	15.33	23.98	19.49	30.00
5230MHz_TnomVnom	Pass	4.16	15.21	15.21	23.98	19.37	30.00
5270MHz_TnomVnom	Pass	4.16	15.08	15.08	23.98	19.24	30.00
5310MHz_TnomVnom	Pass	4.16	15.31	15.31	23.98	19.47	30.00
5510MHz_TnomVnom	Pass	4.16	15.20	15.20	23.98	19.36	30.00
5550MHz_TnomVnom	Pass	4.16	15.21	15.21	23.98	19.37	30.00
5670MHz_TnomVnom	Pass	4.16	15.10	15.10	23.98	19.26	30.00
5710MHz Straddle 5.47-5.725GHz_TnomVnom	Pass	4.16	15.10	15.10	23.98	19.26	30.00
5710MHz Straddle 5.725-5.85GHz_TnomVnom	Pass	4.16	4.37	4.37	30.00	8.53	36.00
5755MHz_TnomVnom	Pass	4.16	15.15	15.15	30.00	19.31	36.00
5795MHz_TnomVnom	Pass	4.16	15.07	15.07	30.00	19.23	36.00
802.11ac VHT80_Nss1,(MCS0)_1TX	-	-	-	-	-	-	-
5210MHz_TnomVnom	Pass	4.16	14.95	14.95	23.98	19.11	30.00



## Average Power

## Appendix C

Mode	Result	DG (dBi)	Port 1 (dBm)	Total Power (dBm)	Power Limit (dBm)	EIRP (dBm)	EIRP Limit (dBm)
5290MHz_TnomVnom	Pass	4.16	13.86	13.86	23.98	18.02	30.00
5530MHz_TnomVnom	Pass	4.16	14.78	14.78	23.98	18.94	30.00
5690MHz Straddle 5.47-5.725GHz_TnomVnom	Pass	4.16	14.92	14.92	23.98	19.08	30.00
5690MHz Straddle 5.725-5.85GHz_TnomVnom	Pass	4.16	0.88	0.88	30.00	5.04	36.00
5775MHz_TnomVnom	Pass	4.16	14.57	14.57	30.00	18.73	36.00

**DG** = Directional Gain; **Port X** = Port X output power



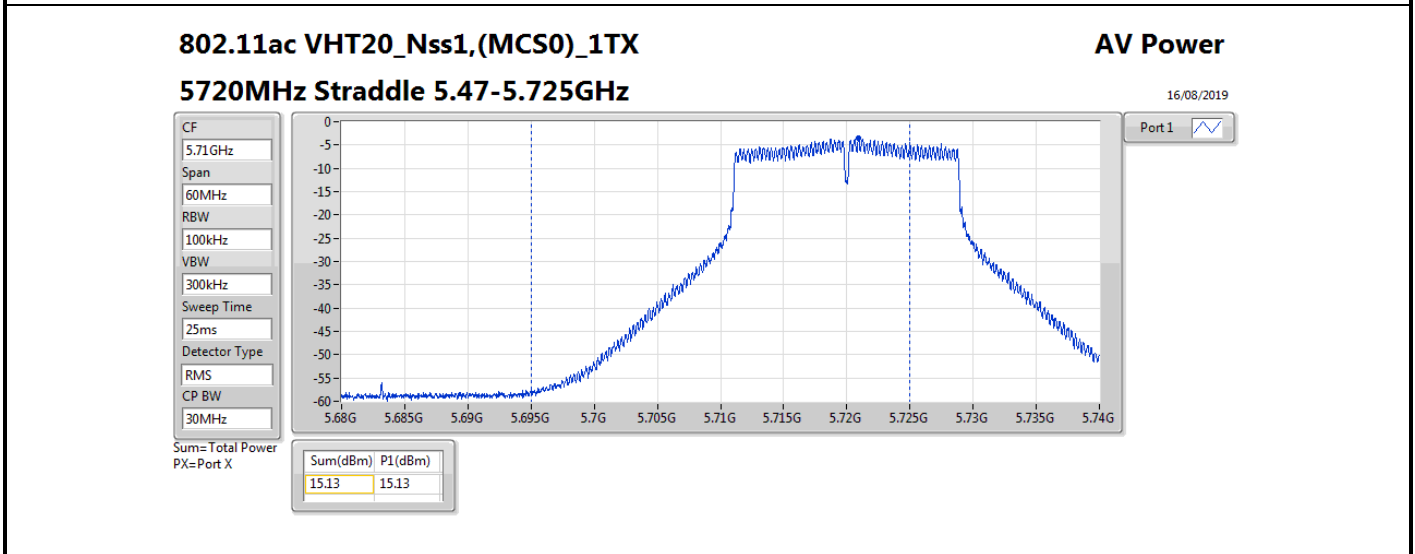
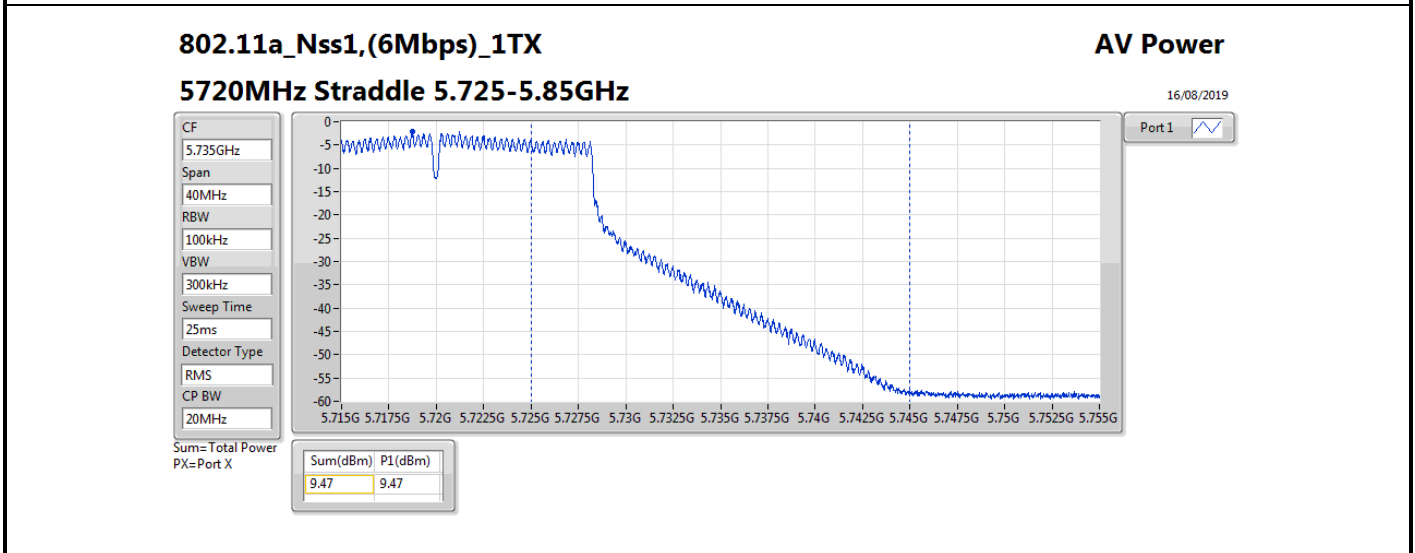
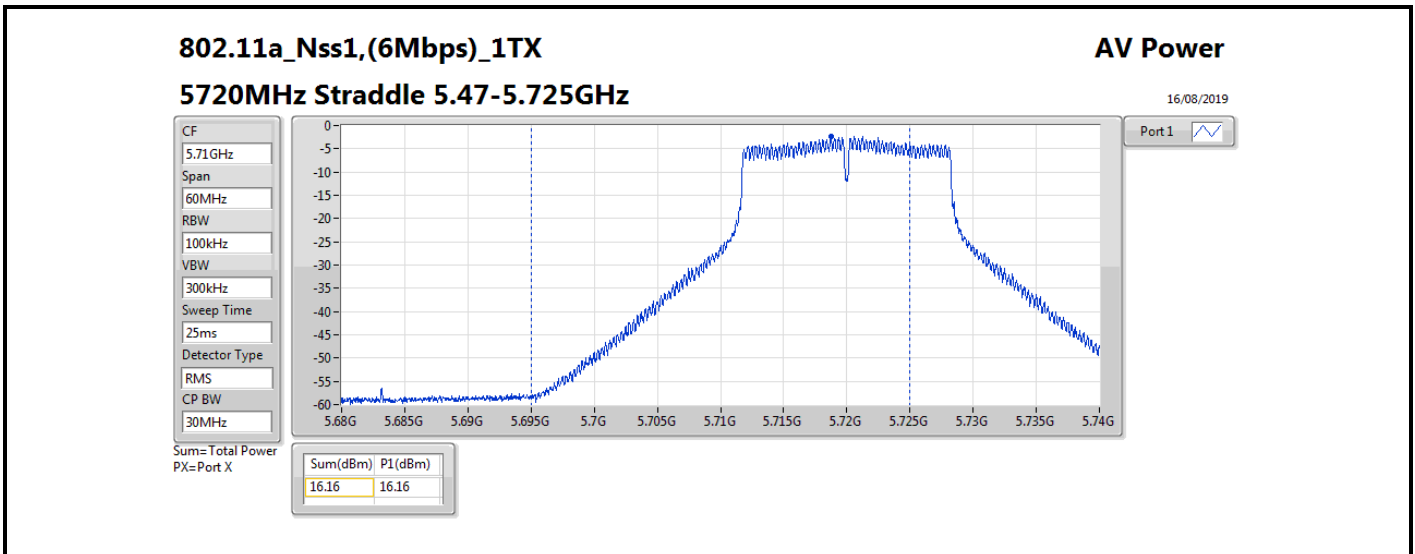

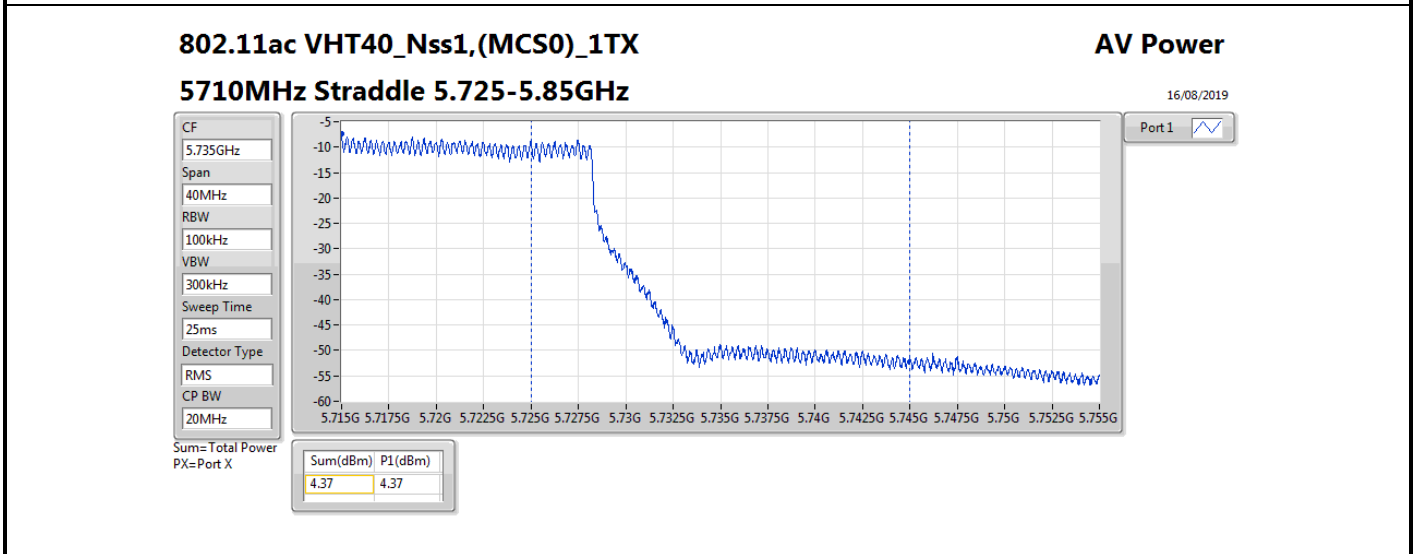
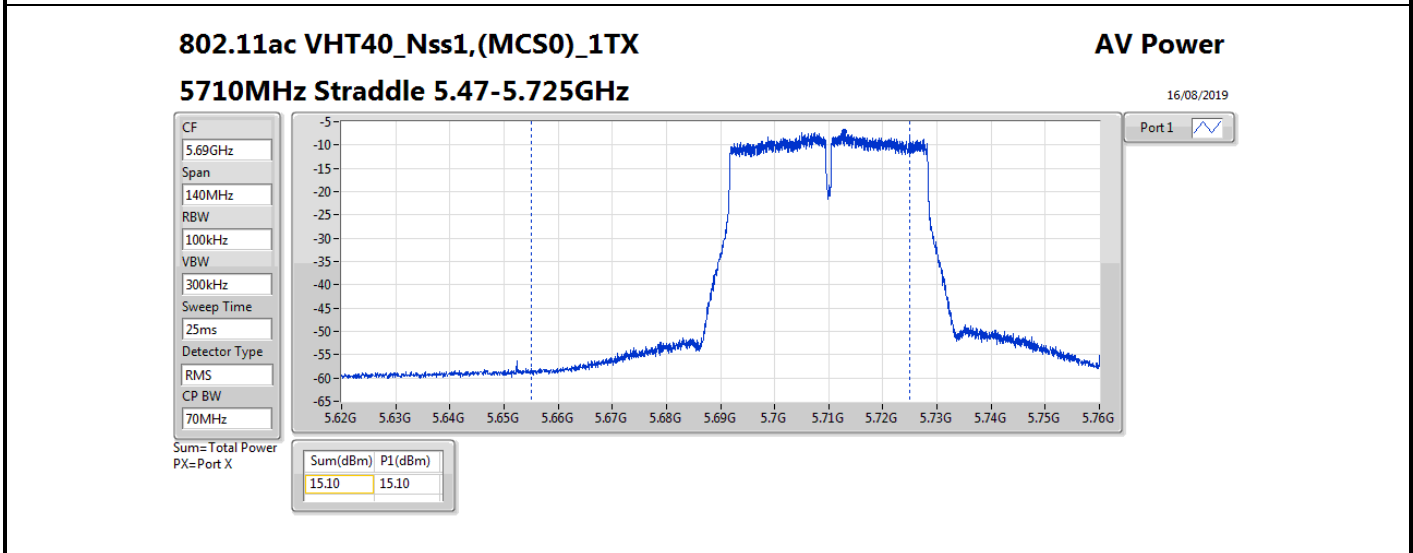
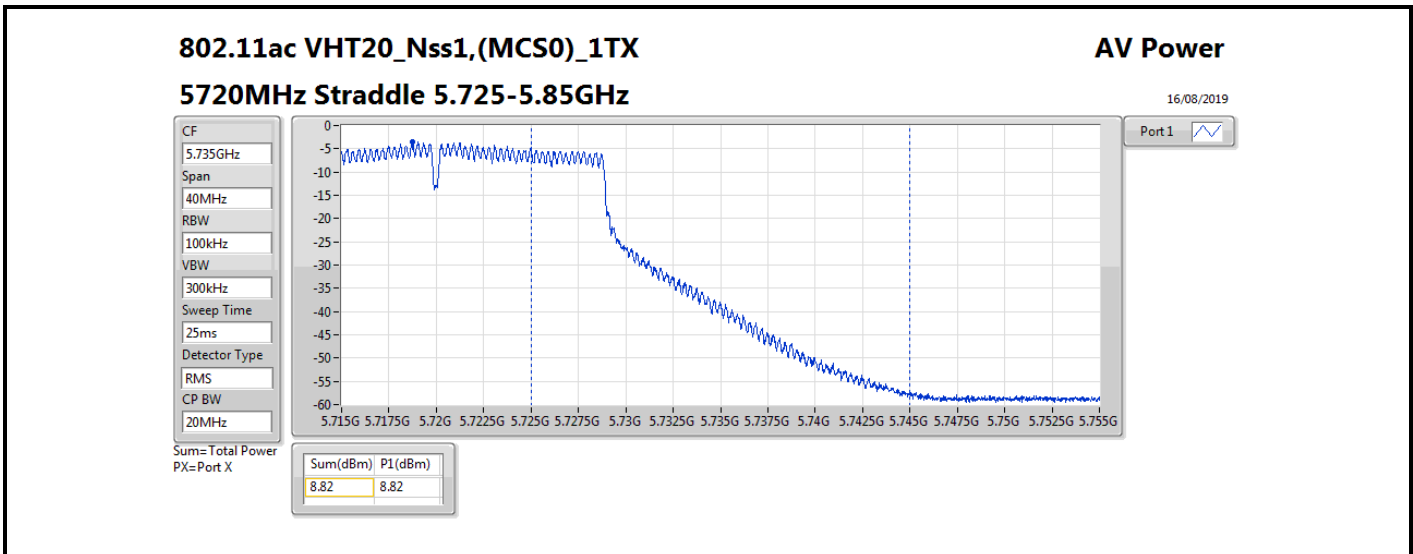

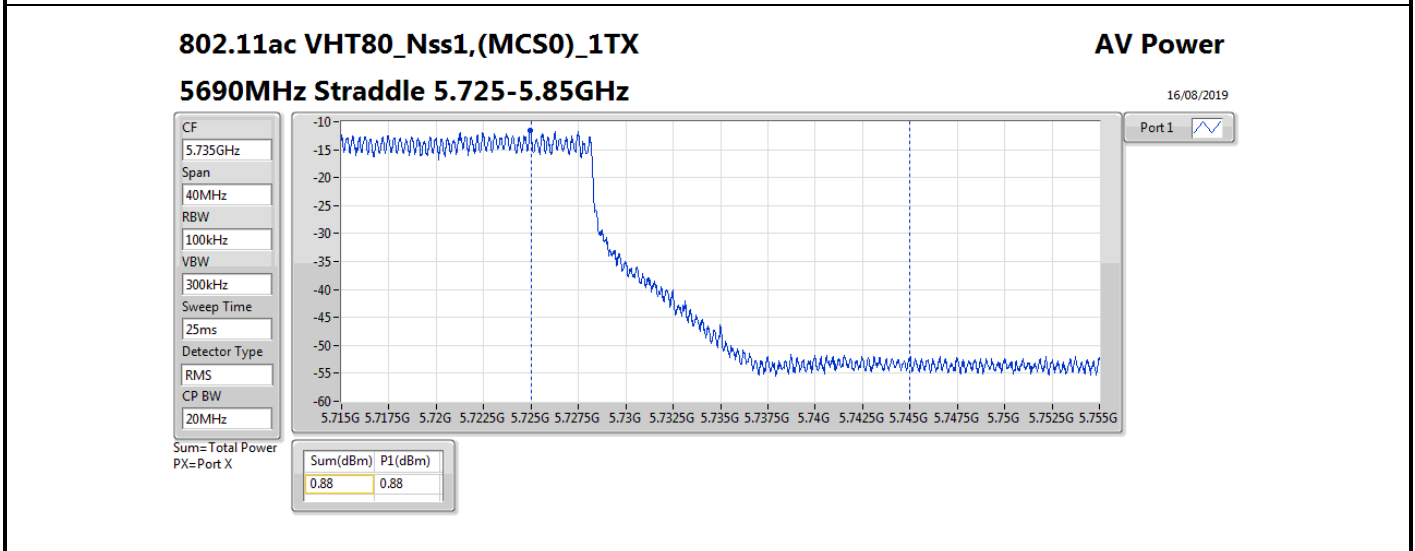
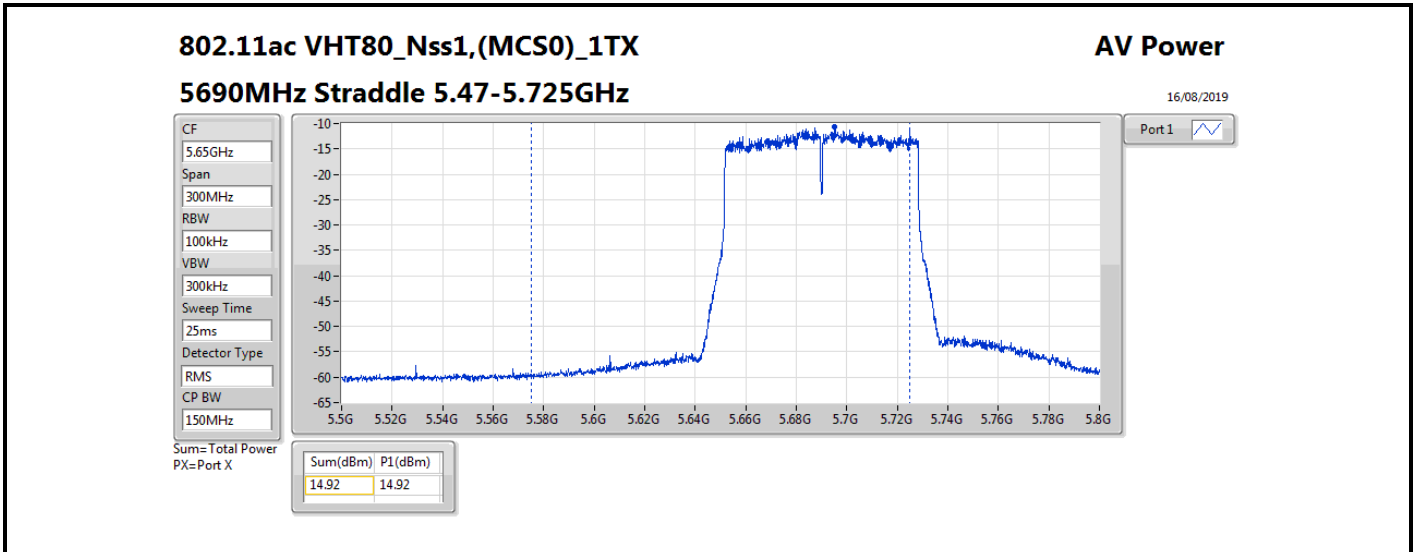

Summary

Mode	PD (dBm/RBW)	EIRP PD (dBm/RBW)
5.15-5.25GHz	-	-
802.11a_Nss1,(6Mbps)_1TX	4.23	8.39
802.11ac VHT20_Nss1,(MCS0)_1TX	3.00	7.16
802.11ac VHT40_Nss1,(MCS0)_1TX	-0.17	3.99
802.11ac VHT80_Nss1,(MCS0)_1TX	-3.51	0.65
5.25-5.35GHz	-	-
802.11a_Nss1,(6Mbps)_1TX	4.27	8.43
802.11ac VHT20_Nss1,(MCS0)_1TX	2.88	7.04
802.11ac VHT40_Nss1,(MCS0)_1TX	-0.15	4.01
802.11ac VHT80_Nss1,(MCS0)_1TX	-4.70	-0.54
5.47-5.725GHz	-	-
802.11a_Nss1,(6Mbps)_1TX	4.79	8.95
802.11ac VHT20_Nss1,(MCS0)_1TX	3.49	7.65
802.11ac VHT40_Nss1,(MCS0)_1TX	-0.24	3.92
802.11ac VHT80_Nss1,(MCS0)_1TX	-3.71	0.45
5.725-5.85GHz	-	-
802.11a_Nss1,(6Mbps)_1TX	2.64	6.80
802.11ac VHT20_Nss1,(MCS0)_1TX	1.24	5.40
802.11ac VHT40_Nss1,(MCS0)_1TX	-1.80	2.36
802.11ac VHT80_Nss1,(MCS0)_1TX	-5.34	-1.18

RBW = 500 kHz for 5.725-5.85GHz band / 1MHz for other band;

**Result**

Mode	Result	DG (dBi)	Port 1 (dBm/RBW)	PD (dBm/RBW)	PD Limit (dBm/RBW)	EIRP PD (dBm/RBW)	EIRP PD Limit (dBm/RBW)
802.11a_Nss1,(6Mbps)_1TX	-	-	-	-	-	-	-
5180MHz_TnomVnom	Pass	4.16	3.94	3.94	11.00	8.10	17.00
5200MHz_TnomVnom	Pass	4.16	3.88	3.88	11.00	8.04	17.00
5240MHz_TnomVnom	Pass	4.16	4.23	4.23	11.00	8.39	17.00
5260MHz_TnomVnom	Pass	4.16	4.21	4.21	11.00	8.37	17.00
5300MHz_TnomVnom	Pass	4.16	4.27	4.27	11.00	8.43	17.00
5320MHz_TnomVnom	Pass	4.16	4.22	4.22	11.00	8.38	17.00
5500MHz_TnomVnom	Pass	4.16	4.24	4.24	11.00	8.40	17.00
5580MHz_TnomVnom	Pass	4.16	3.98	3.98	11.00	8.14	17.00
5700MHz_TnomVnom	Pass	4.16	4.24	4.24	11.00	8.40	17.00
5720MHz Straddle 5.47-5.725GHz_TnomVnom	Pass	4.16	4.79	4.79	11.00	8.95	17.00
5720MHz Straddle 5.725-5.85GHz_TnomVnom	Pass	4.16	1.97	1.97	30.00	6.13	36.00
5745MHz_TnomVnom	Pass	4.16	2.64	2.64	30.00	6.80	36.00
5785MHz_TnomVnom	Pass	4.16	2.53	2.53	30.00	6.69	36.00
5825MHz_TnomVnom	Pass	4.16	2.58	2.58	30.00	6.74	36.00
802.11ac VHT20_Nss1,(MCS0)_1TX	-	-	-	-	-	-	-
5180MHz_TnomVnom	Pass	4.16	3.00	3.00	11.00	7.16	17.00
5200MHz_TnomVnom	Pass	4.16	2.99	2.99	11.00	7.15	17.00
5240MHz_TnomVnom	Pass	4.16	2.85	2.85	11.00	7.01	17.00
5260MHz_TnomVnom	Pass	4.16	2.81	2.81	11.00	6.97	17.00
5300MHz_TnomVnom	Pass	4.16	2.88	2.88	11.00	7.04	17.00
5320MHz_TnomVnom	Pass	4.16	2.86	2.86	11.00	7.02	17.00
5500MHz_TnomVnom	Pass	4.16	2.84	2.84	11.00	7.00	17.00
5580MHz_TnomVnom	Pass	4.16	2.54	2.54	11.00	6.70	17.00
5700MHz_TnomVnom	Pass	4.16	2.94	2.94	11.00	7.10	17.00
5720MHz Straddle 5.47-5.725GHz_TnomVnom	Pass	4.16	3.49	3.49	11.00	7.65	17.00
5720MHz Straddle 5.725-5.85GHz_TnomVnom	Pass	4.16	0.55	0.55	30.00	4.71	36.00
5745MHz_TnomVnom	Pass	4.16	1.21	1.21	30.00	5.37	36.00
5785MHz_TnomVnom	Pass	4.16	1.24	1.24	30.00	5.40	36.00
5825MHz_TnomVnom	Pass	4.16	1.21	1.21	30.00	5.37	36.00
802.11ac VHT40_Nss1,(MCS0)_1TX	-	-	-	-	-	-	-
5190MHz_TnomVnom	Pass	4.16	-0.17	-0.17	11.00	3.99	17.00
5230MHz_TnomVnom	Pass	4.16	-0.18	-0.18	11.00	3.98	17.00
5270MHz_TnomVnom	Pass	4.16	-0.21	-0.21	11.00	3.95	17.00
5310MHz_TnomVnom	Pass	4.16	-0.15	-0.15	11.00	4.01	17.00
5510MHz_TnomVnom	Pass	4.16	-0.32	-0.32	11.00	3.84	17.00
5550MHz_TnomVnom	Pass	4.16	-0.24	-0.24	11.00	3.92	17.00
5670MHz_TnomVnom	Pass	4.16	-0.40	-0.40	11.00	3.76	17.00
5710MHz Straddle 5.47-5.725GHz_TnomVnom	Pass	4.16	-0.24	-0.24	11.00	3.92	17.00
5710MHz Straddle 5.725-5.85GHz_TnomVnom	Pass	4.16	-3.36	-3.36	30.00	0.80	36.00
5755MHz_TnomVnom	Pass	4.16	-1.80	-1.80	30.00	2.36	36.00
5795MHz_TnomVnom	Pass	4.16	-1.86	-1.86	30.00	2.30	36.00
802.11ac VHT80_Nss1,(MCS0)_1TX	-	-	-	-	-	-	-
5210MHz_TnomVnom	Pass	4.16	-3.51	-3.51	11.00	0.65	17.00



Mode	Result	DG (dBi)	Port 1 (dBm/RBW)	PD (dBm/RBW)	PD Limit (dBm/RBW)	EIRP PD (dBm/RBW)	EIRP PD Limit (dBm/RBW)
5290MHz_TnomVnom	Pass	4.16	-4.70	-4.70	11.00	-0.54	17.00
5530MHz_TnomVnom	Pass	4.16	-3.71	-3.71	11.00	0.45	17.00
5690MHz Straddle 5.47-5.725GHz_TnomVnom	Pass	4.16	-3.86	-3.86	11.00	0.30	17.00
5690MHz Straddle 5.725-5.85GHz_TnomVnom	Pass	4.16	-6.49	-6.49	30.00	-2.33	36.00
5775MHz_TnomVnom	Pass	4.16	-5.34	-5.34	30.00	-1.18	36.00

**DG** = Directional Gain; **RBW** = 500 kHz for 5.725-5.85GHz band / 1MHz for other band;

**PD** = trace bin-by-bin of each transmits port summing can be performed maximum power density; **Port X** = Port X power density;

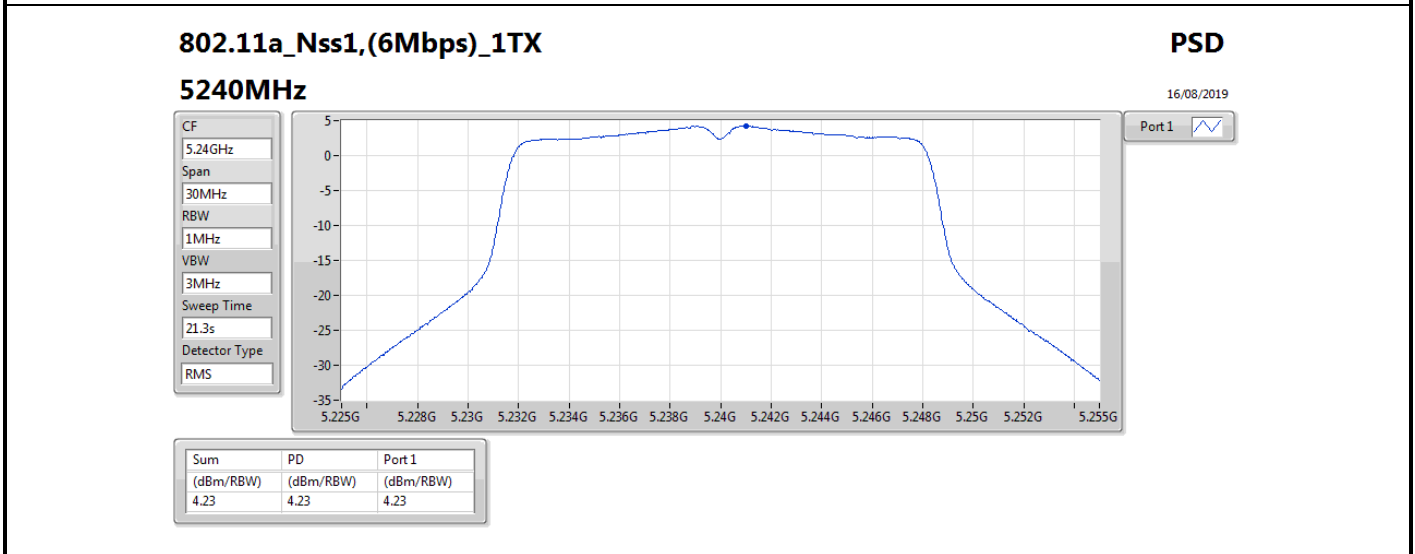
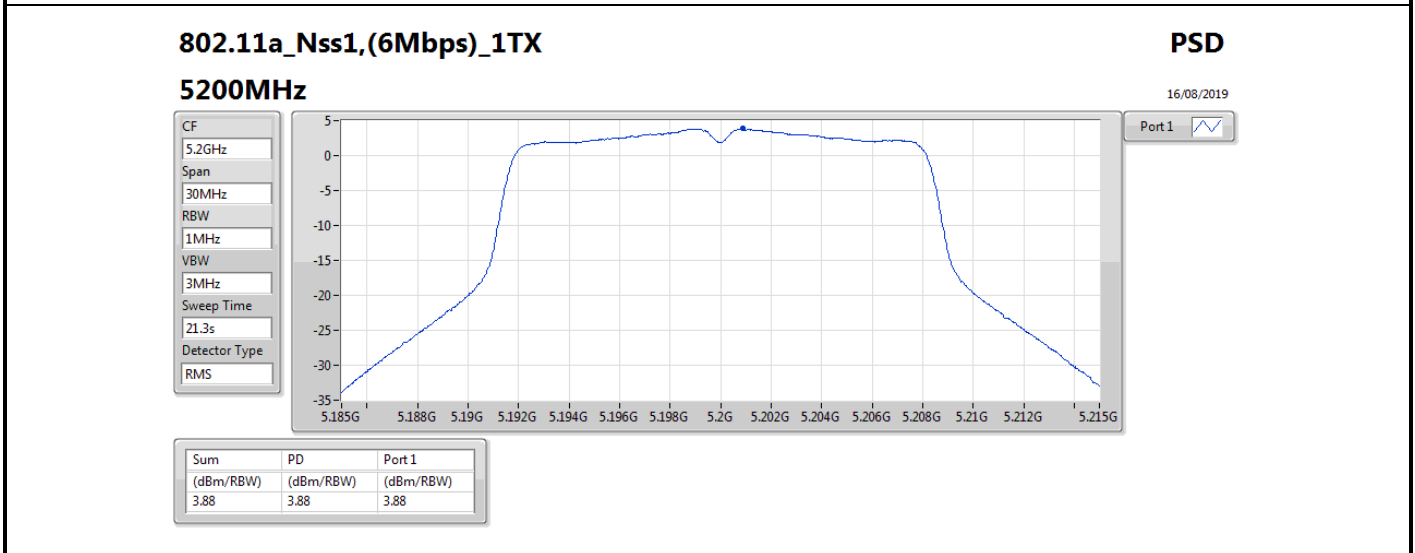
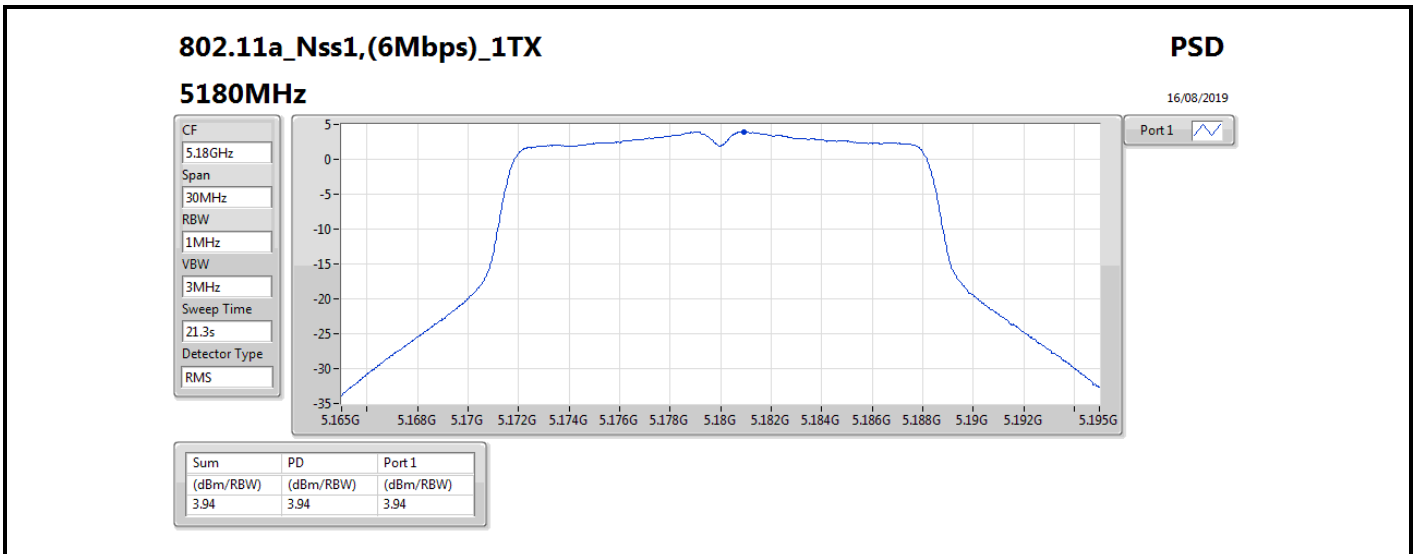

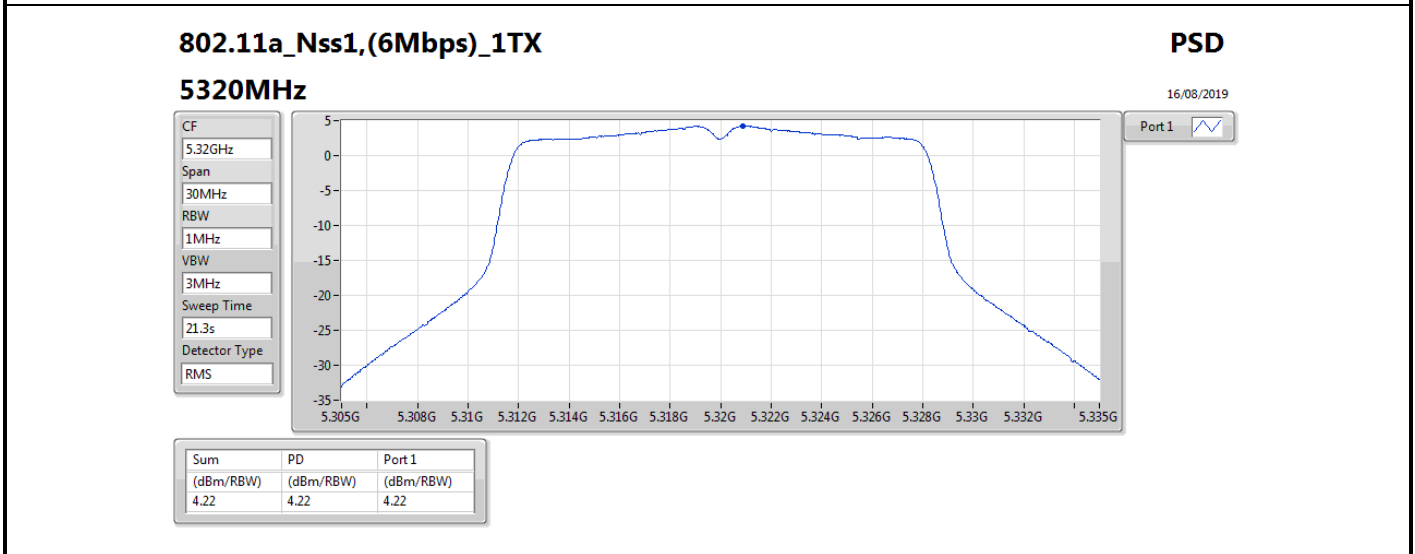
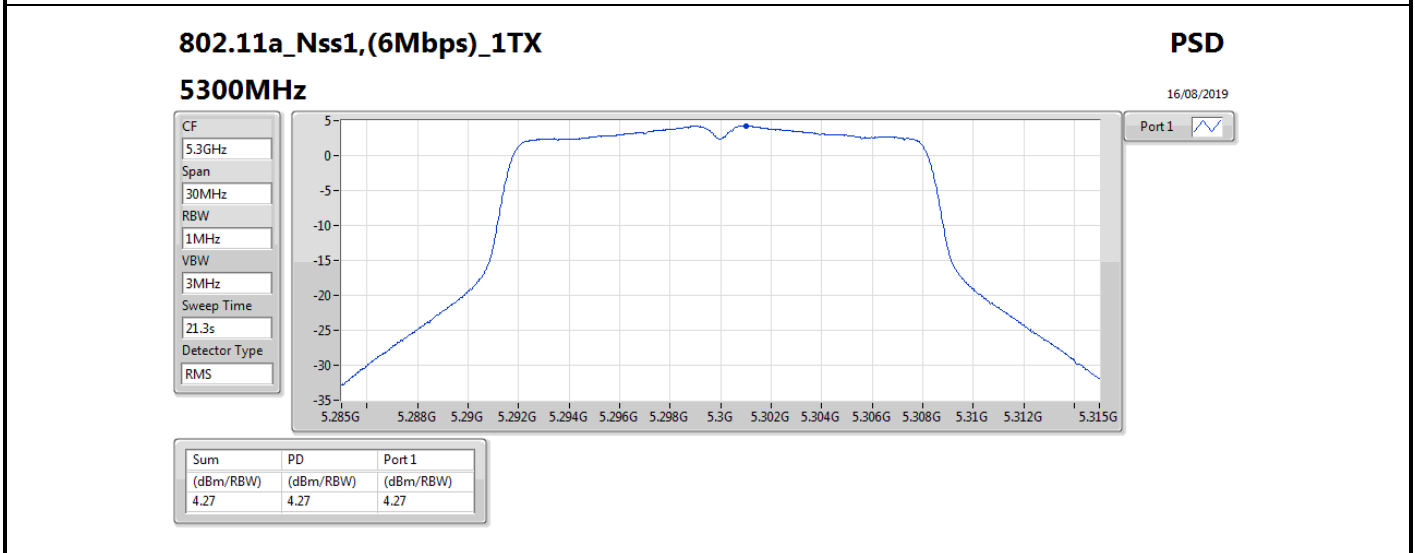
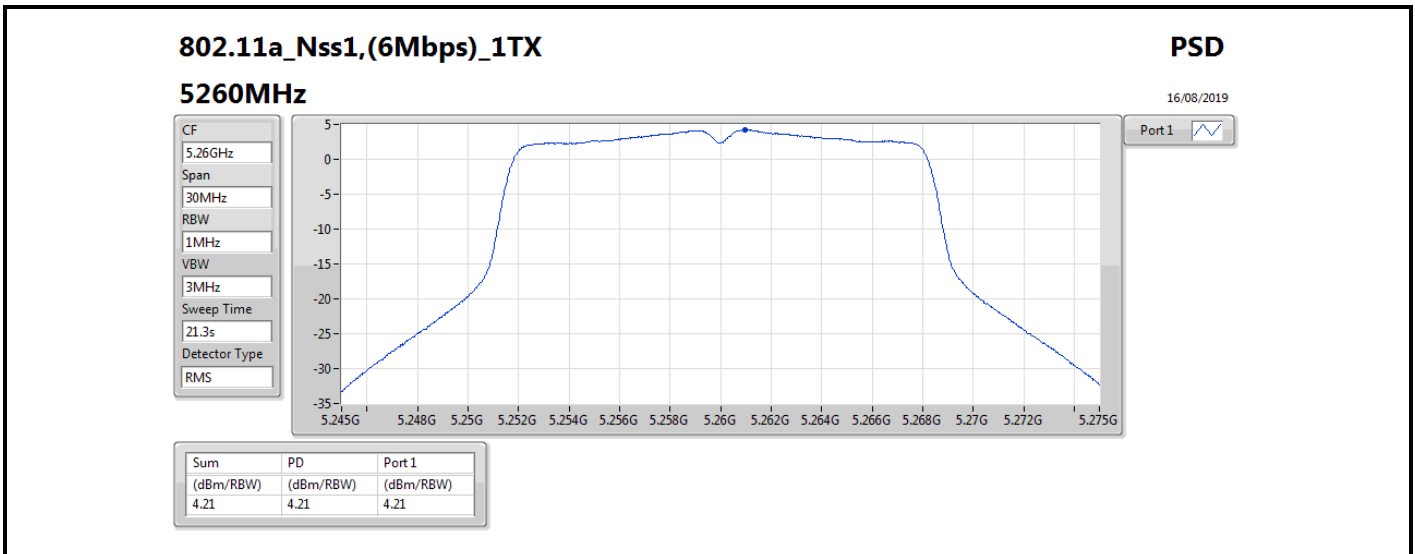



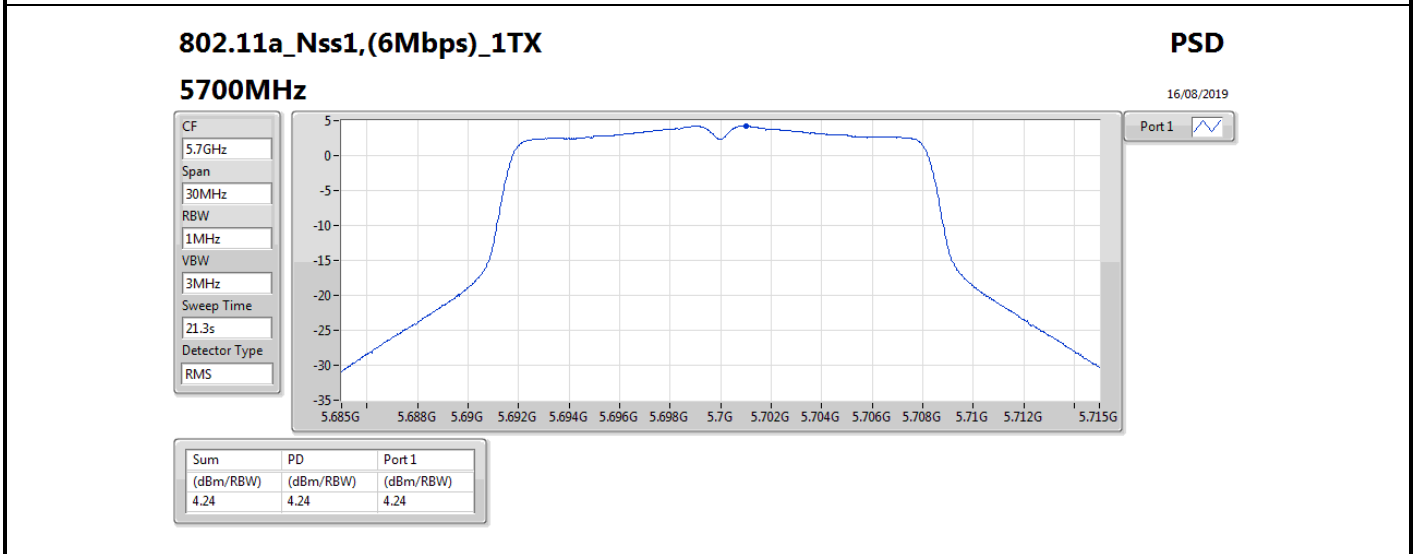
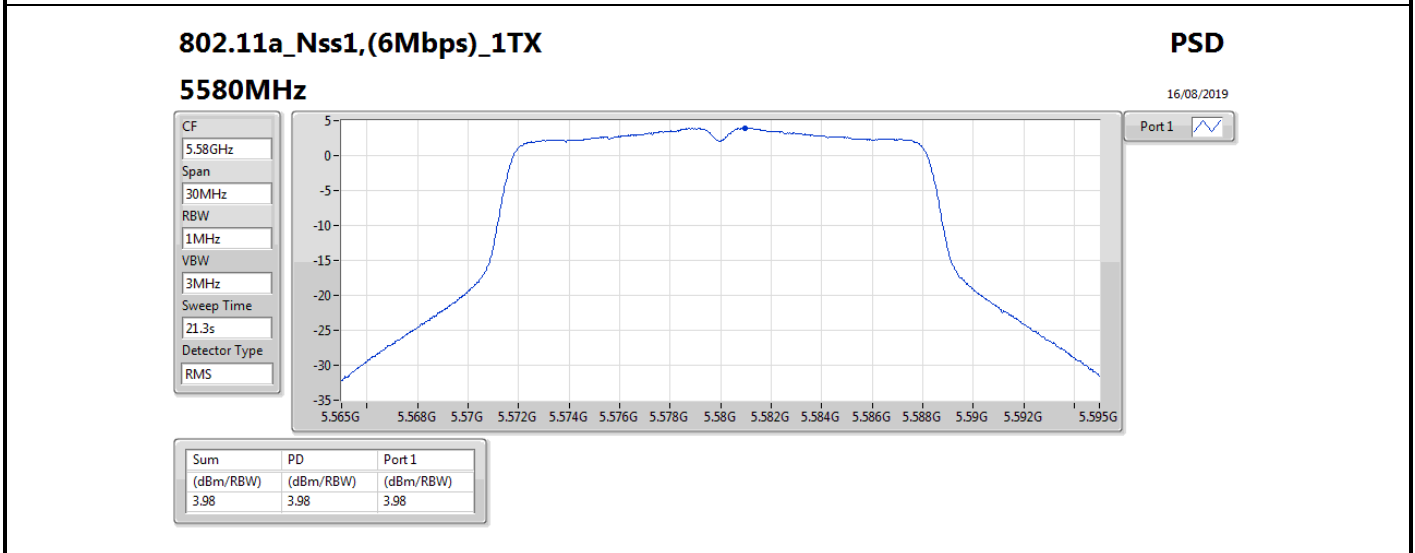
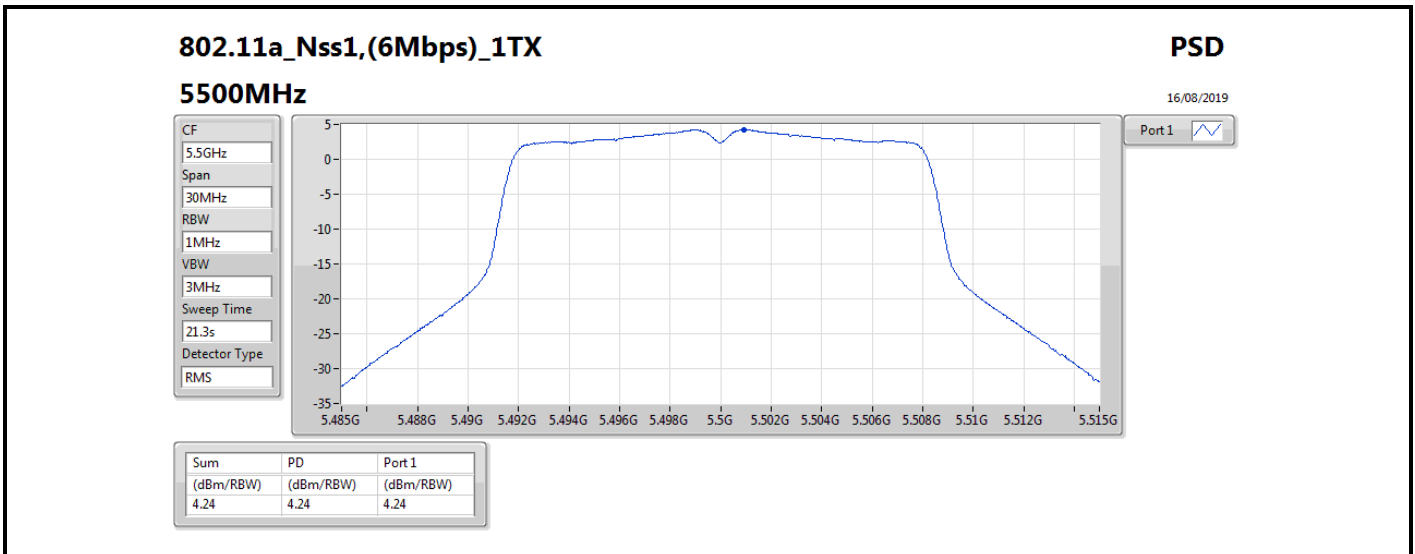

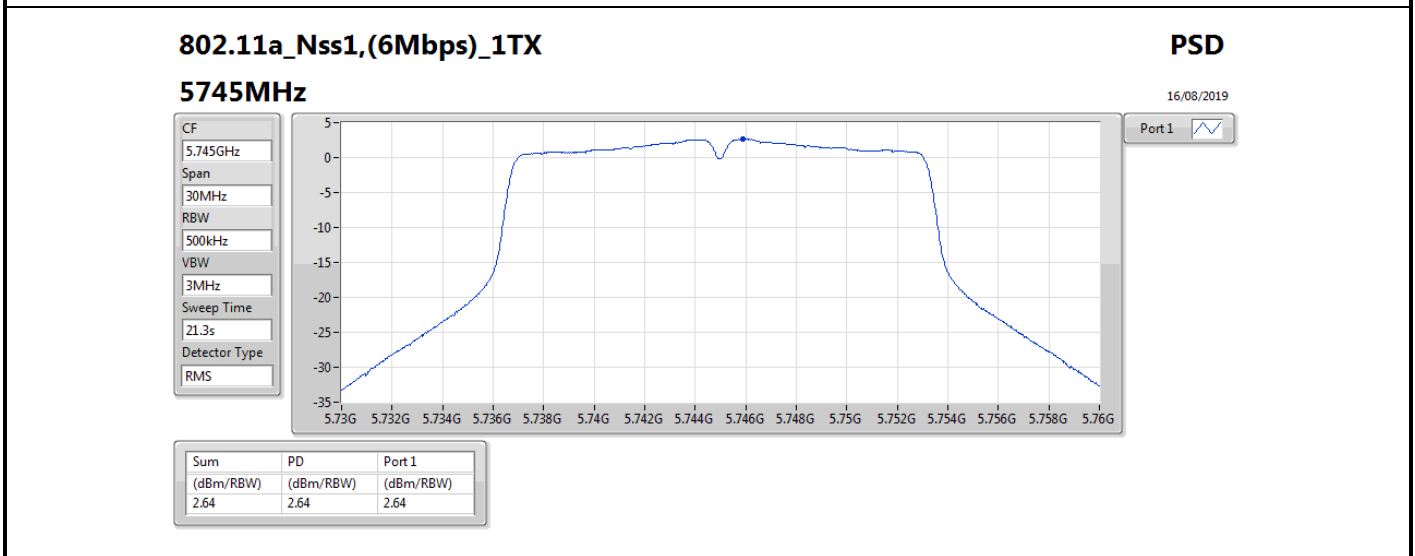
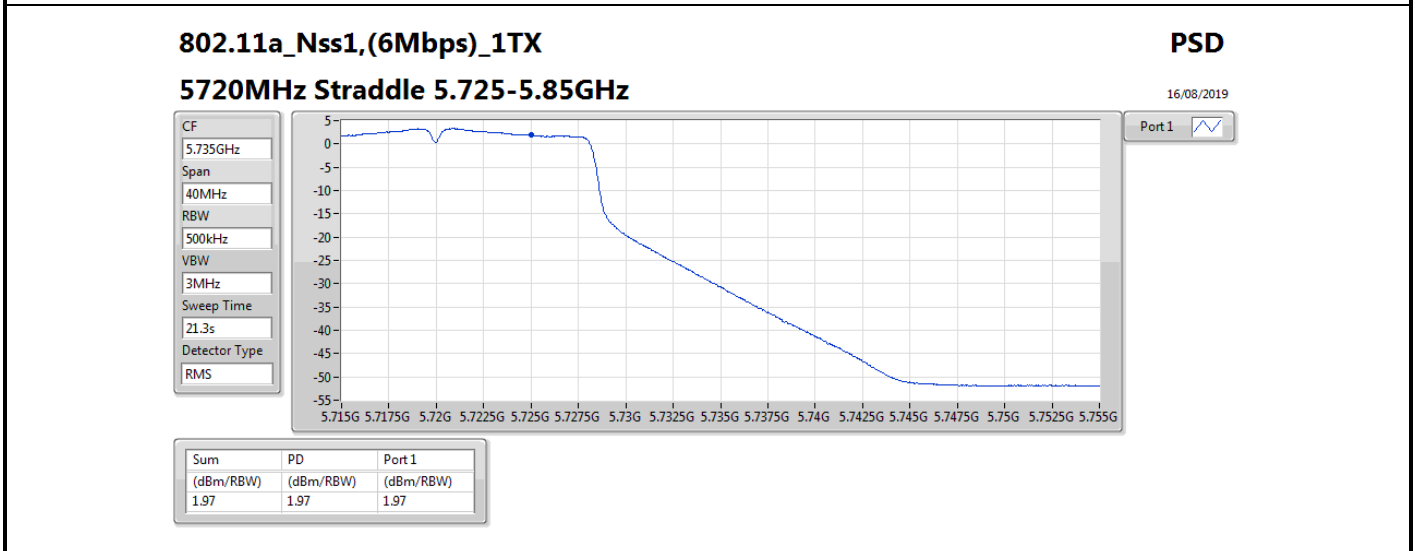
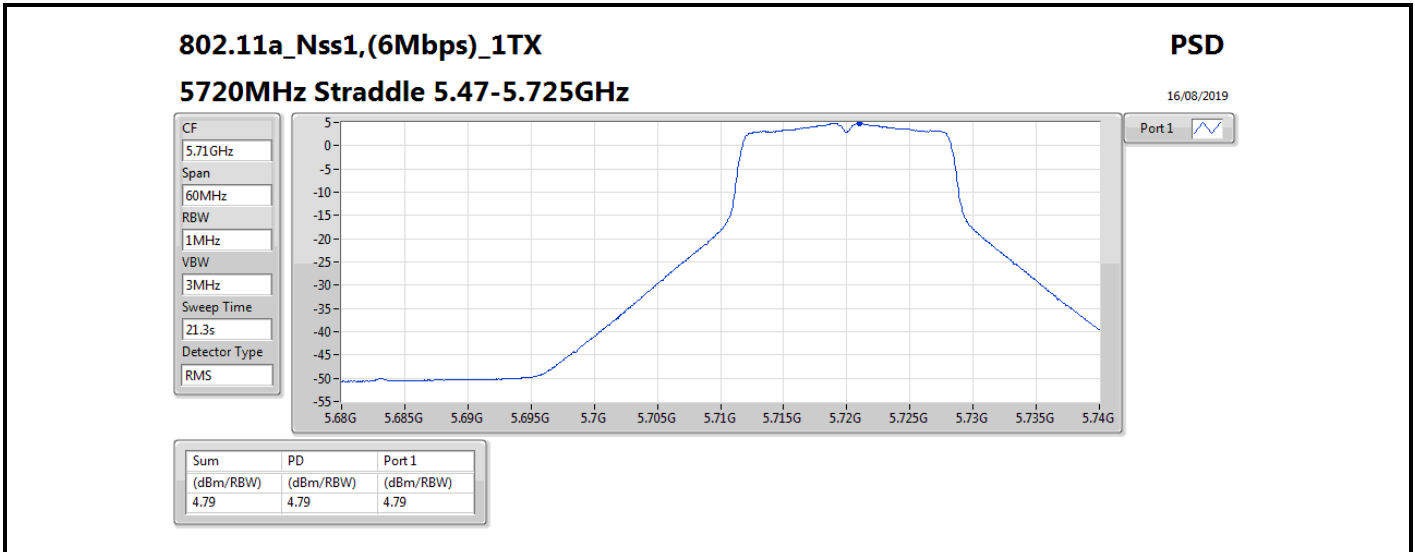

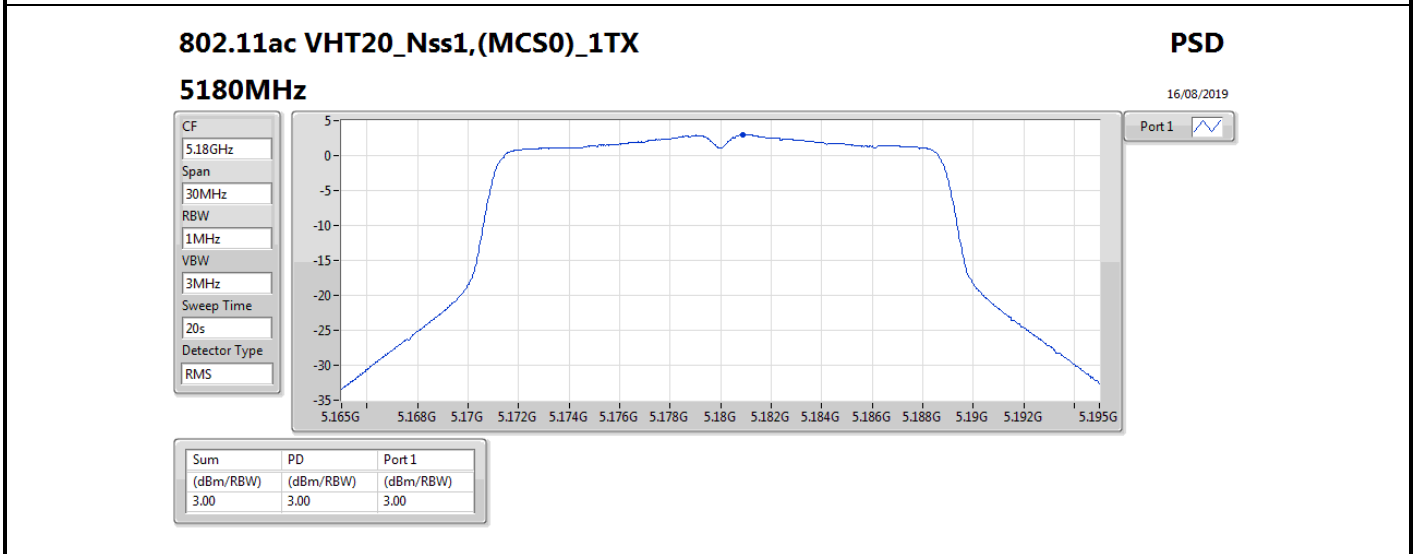
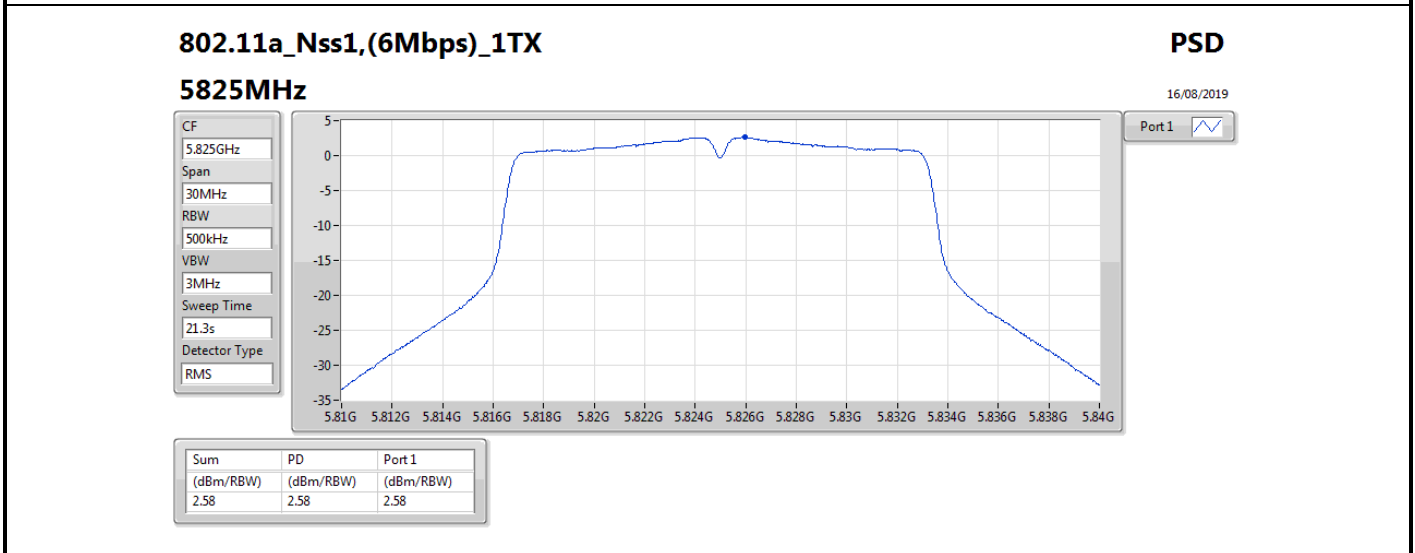
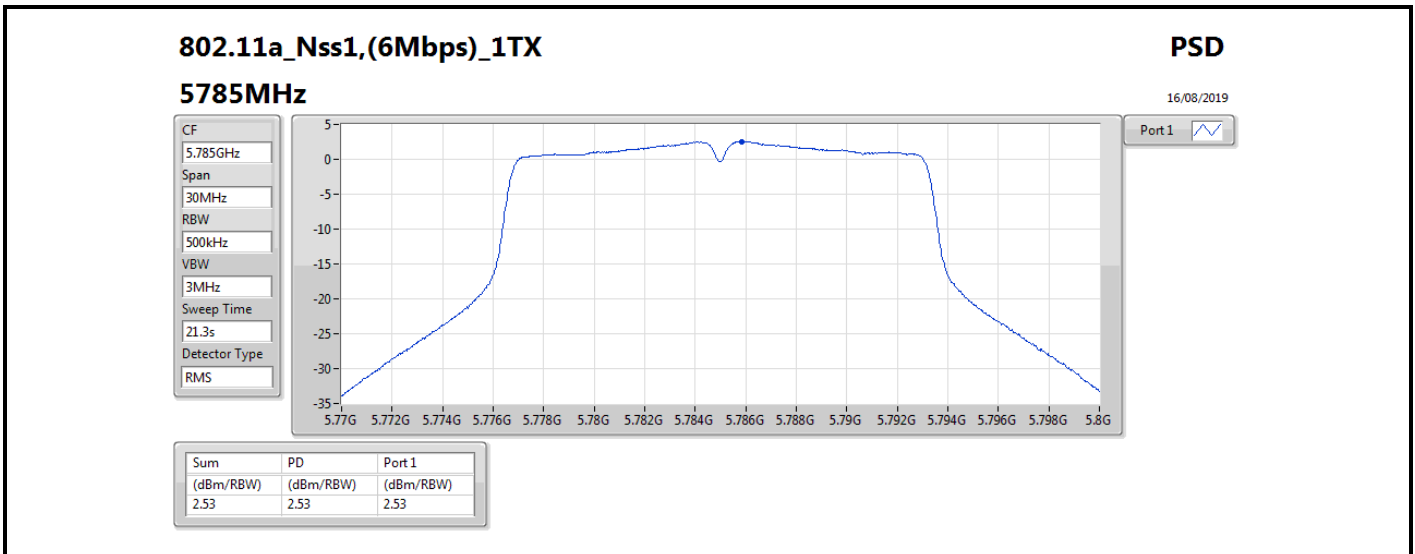

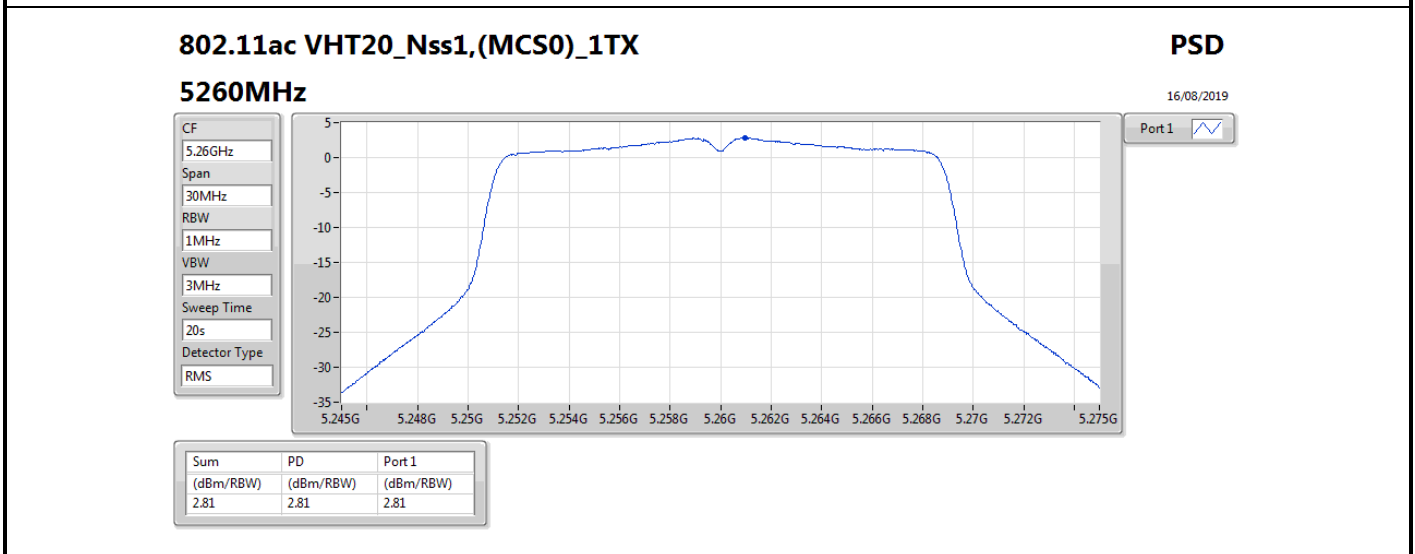
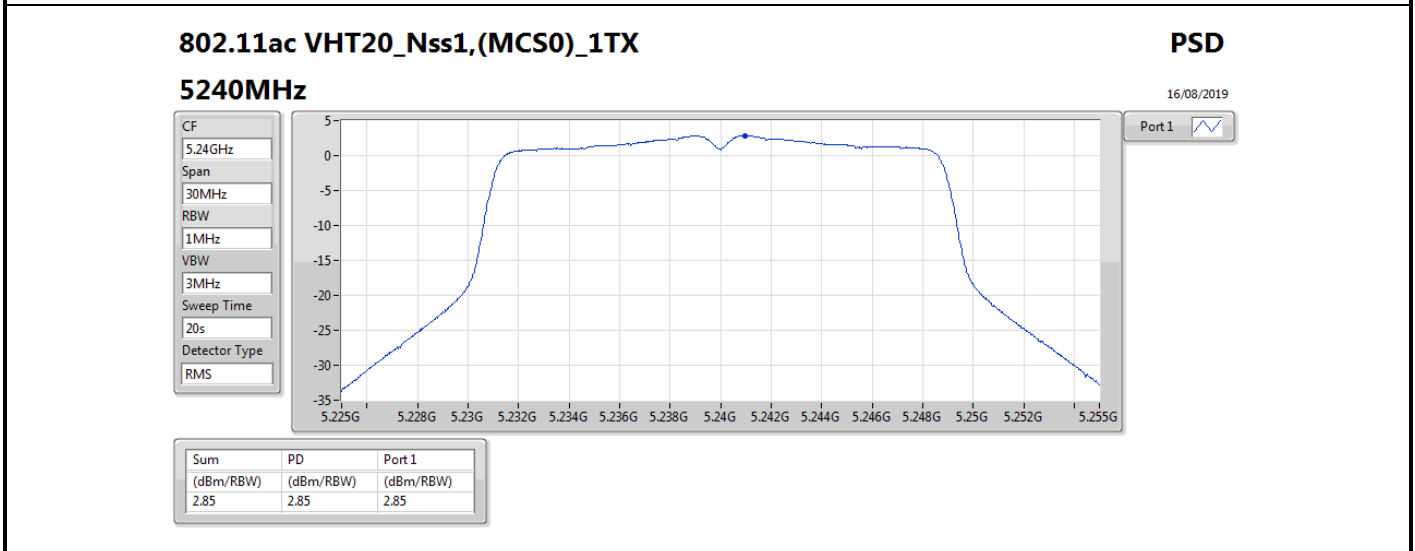
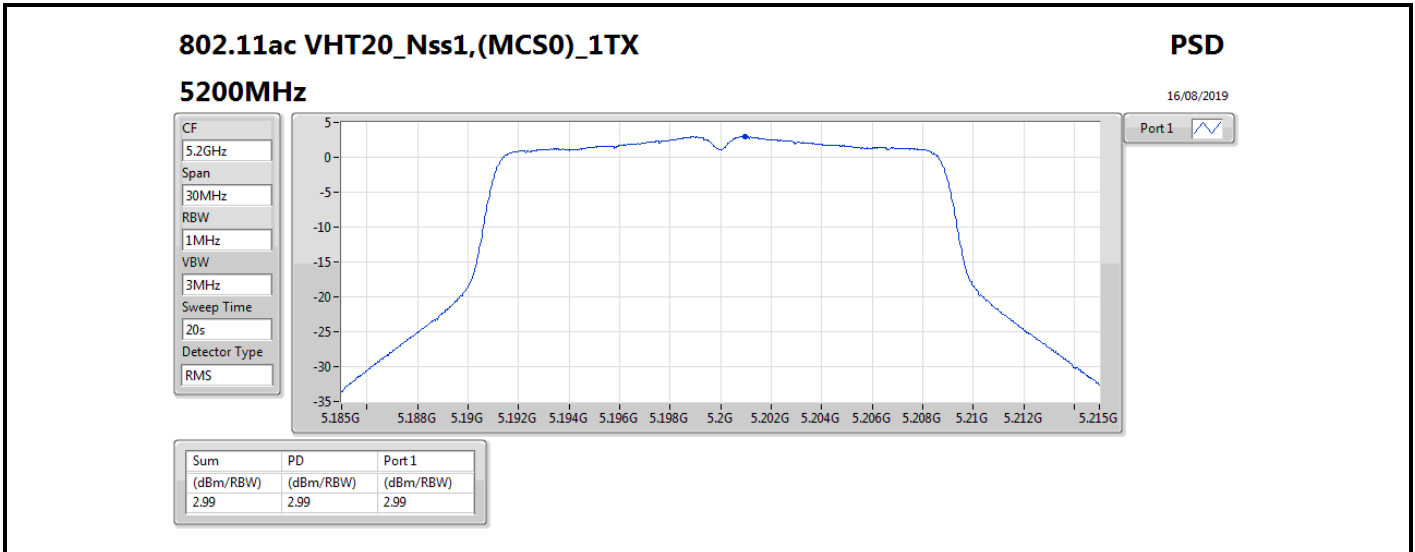

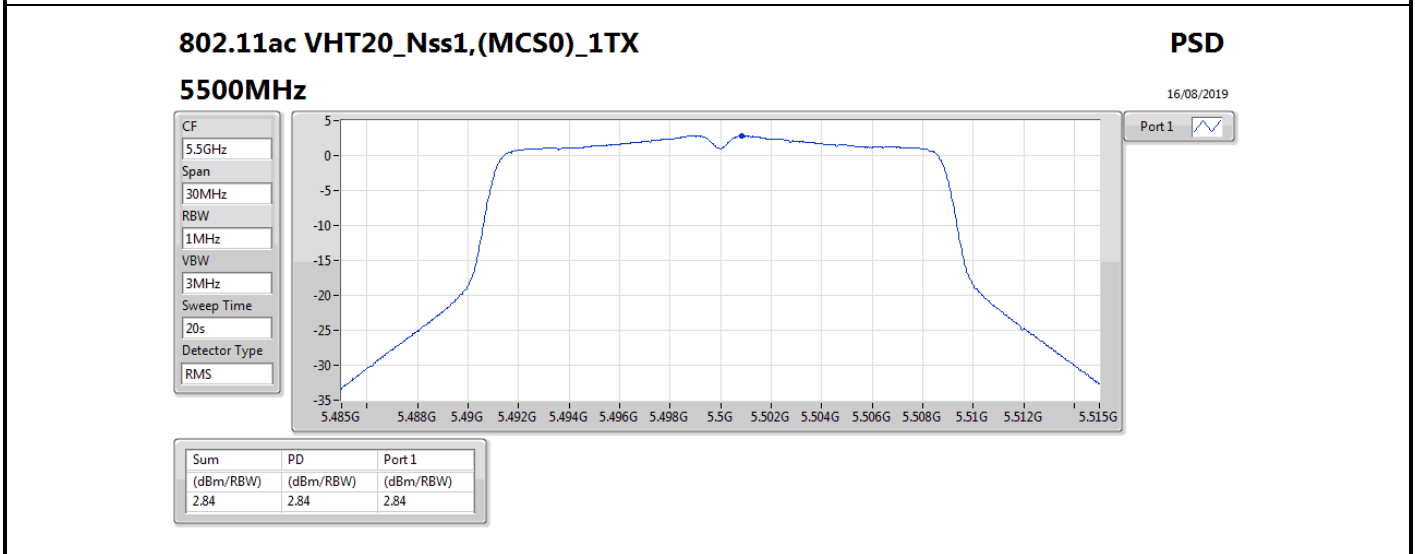
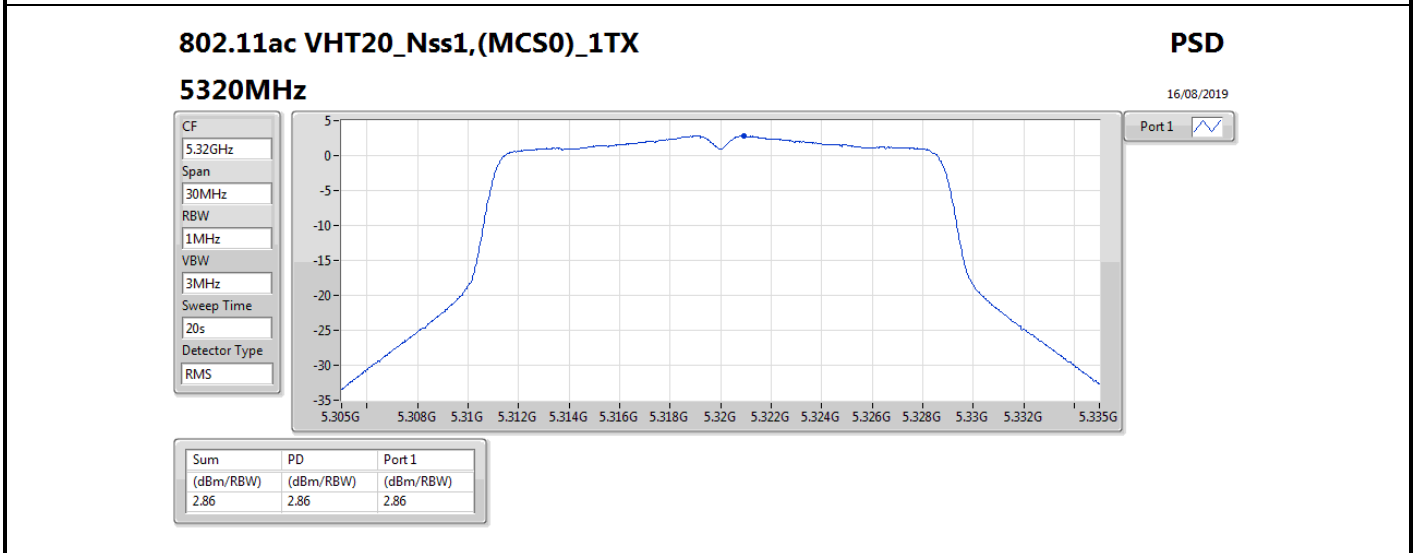
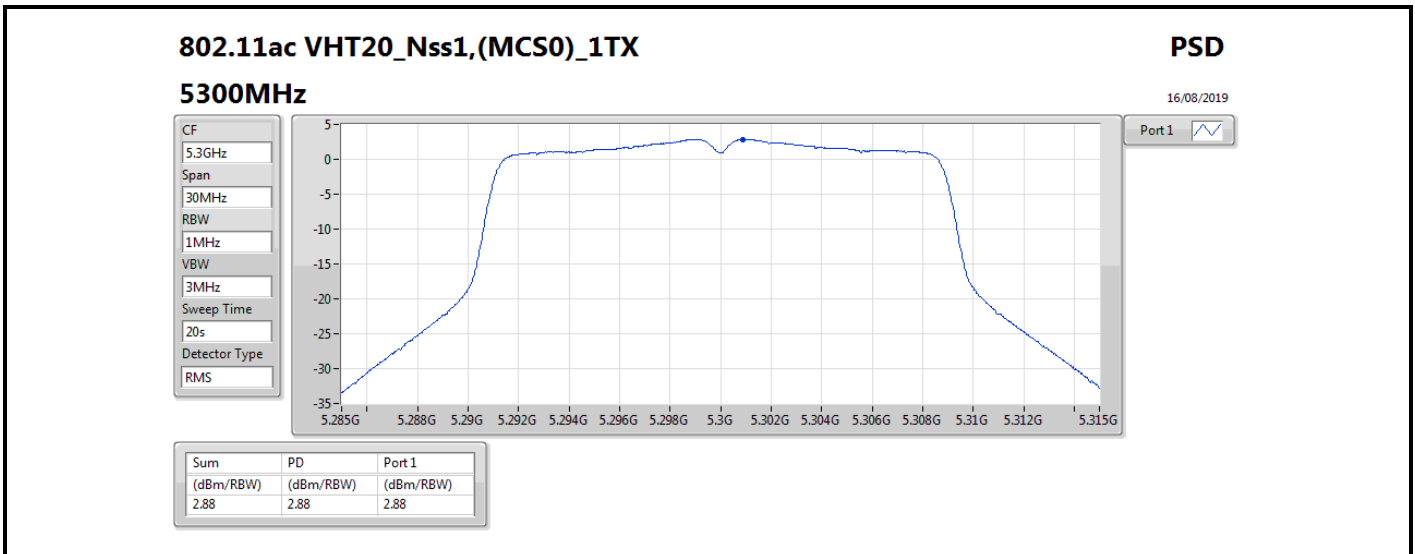

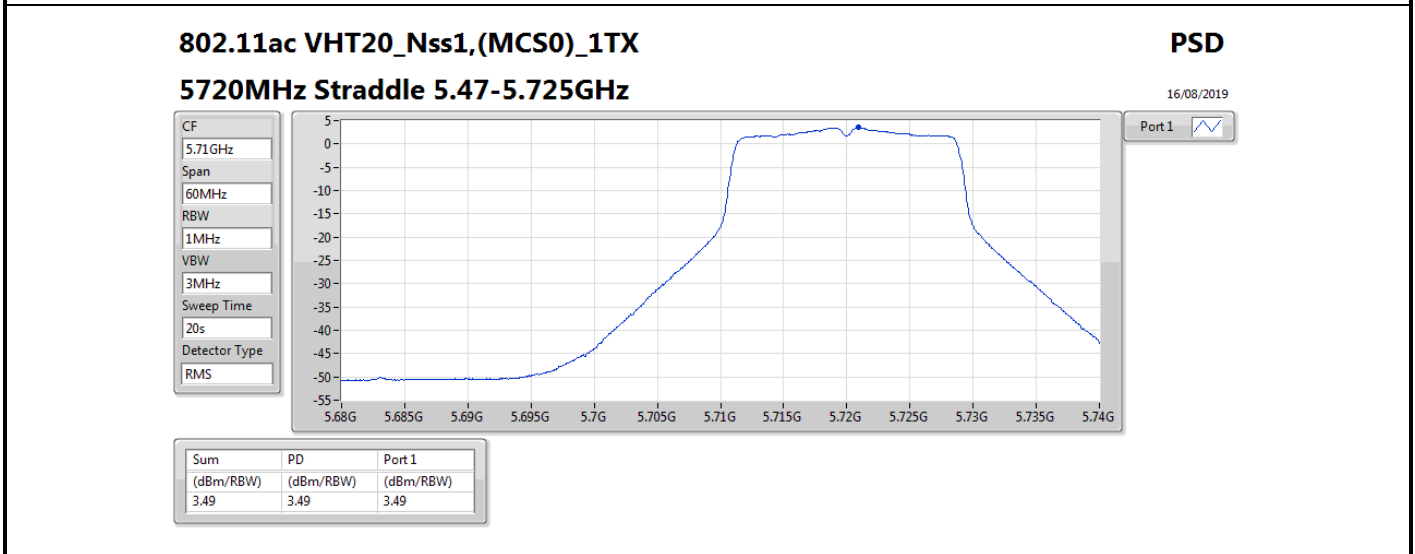
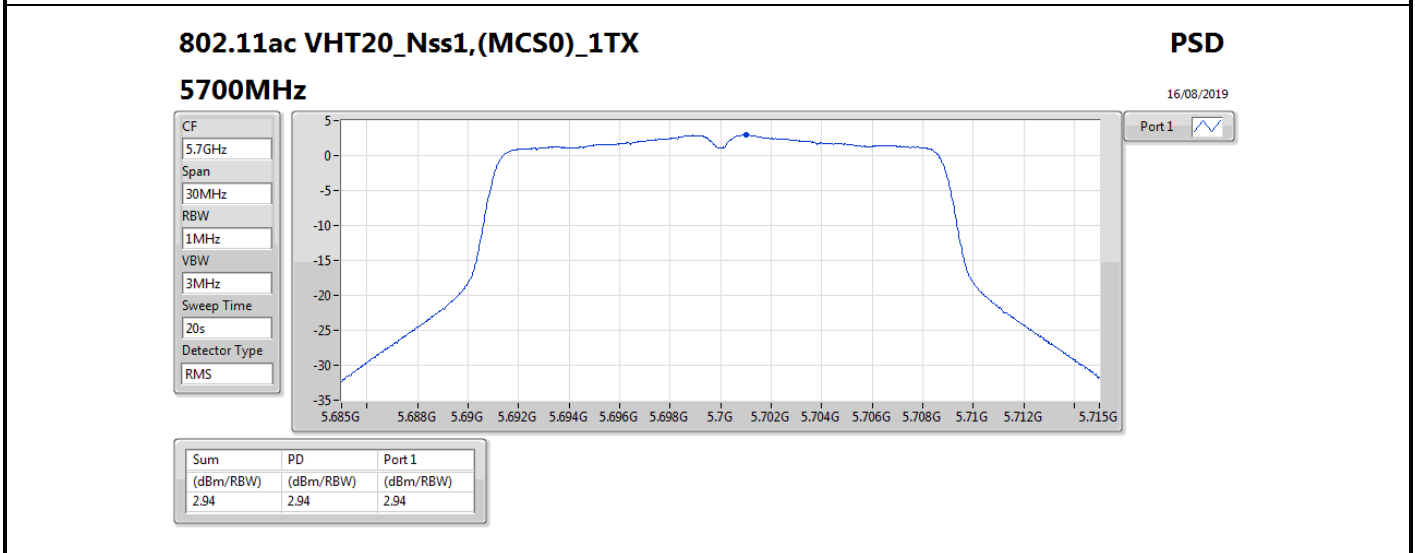
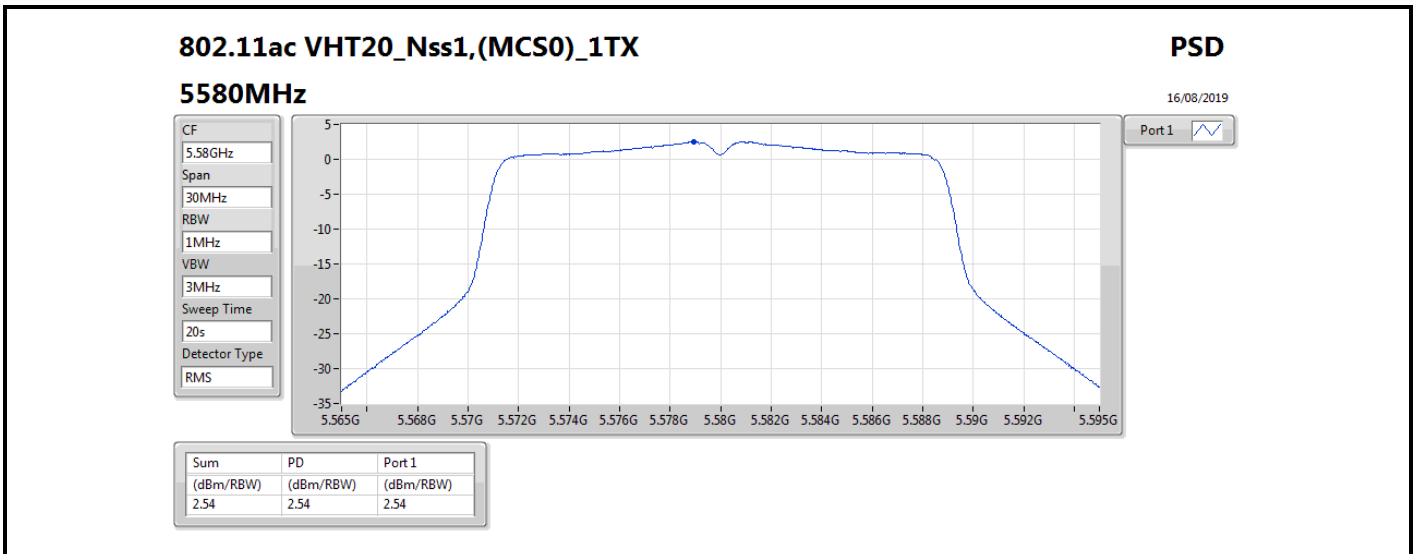

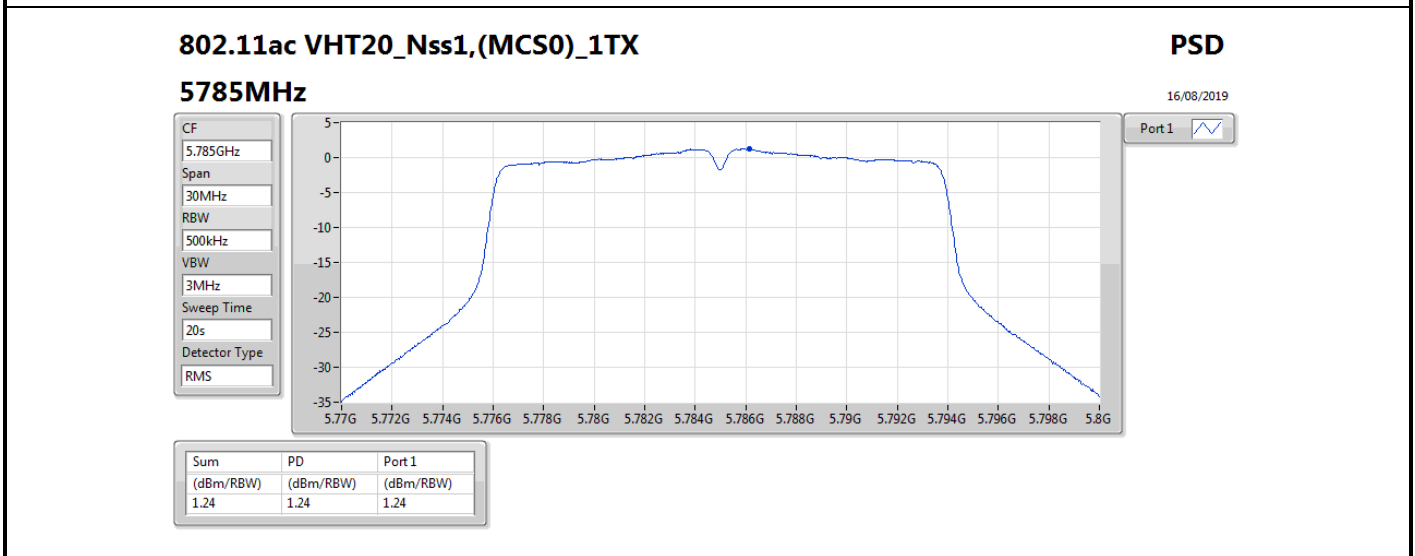
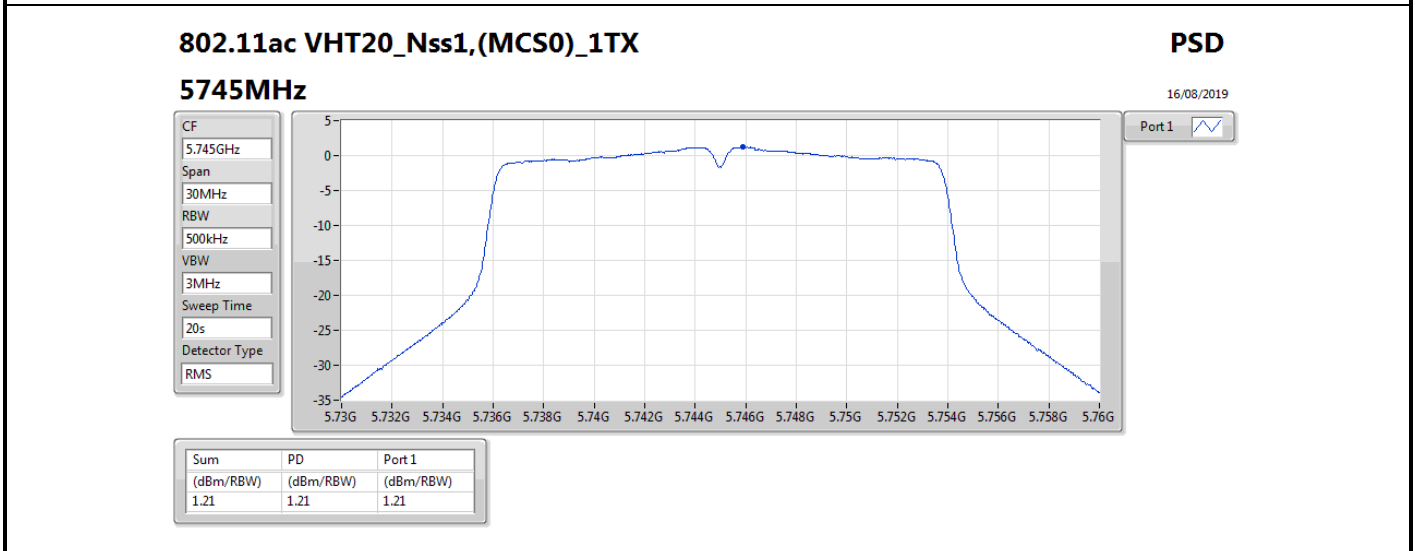
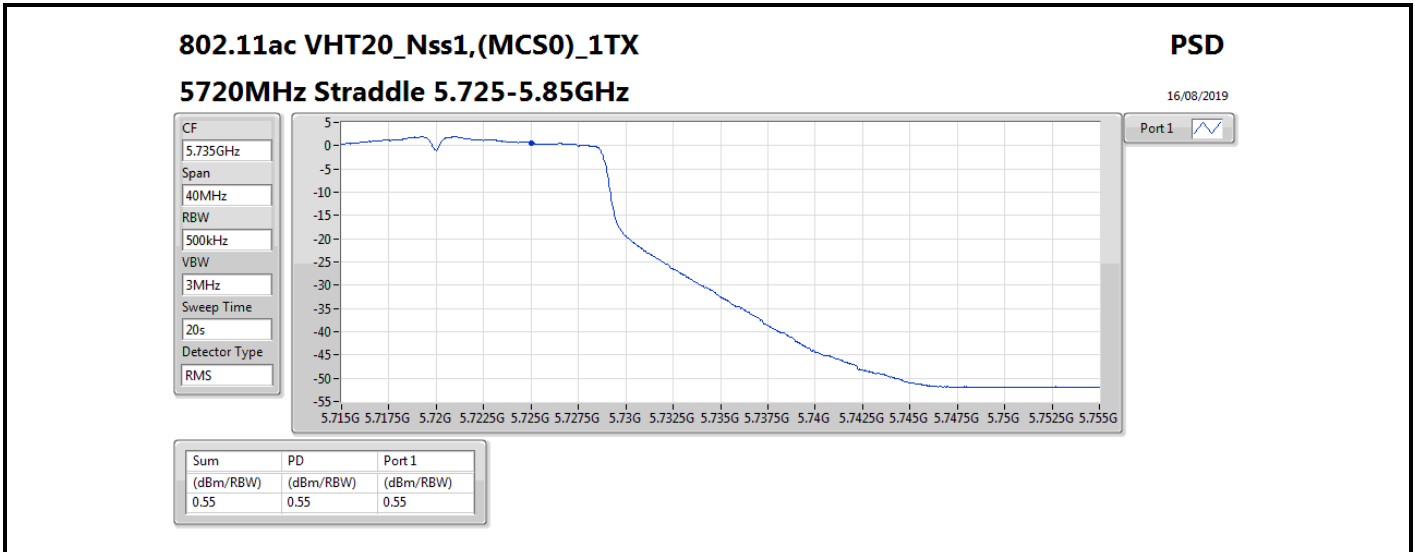

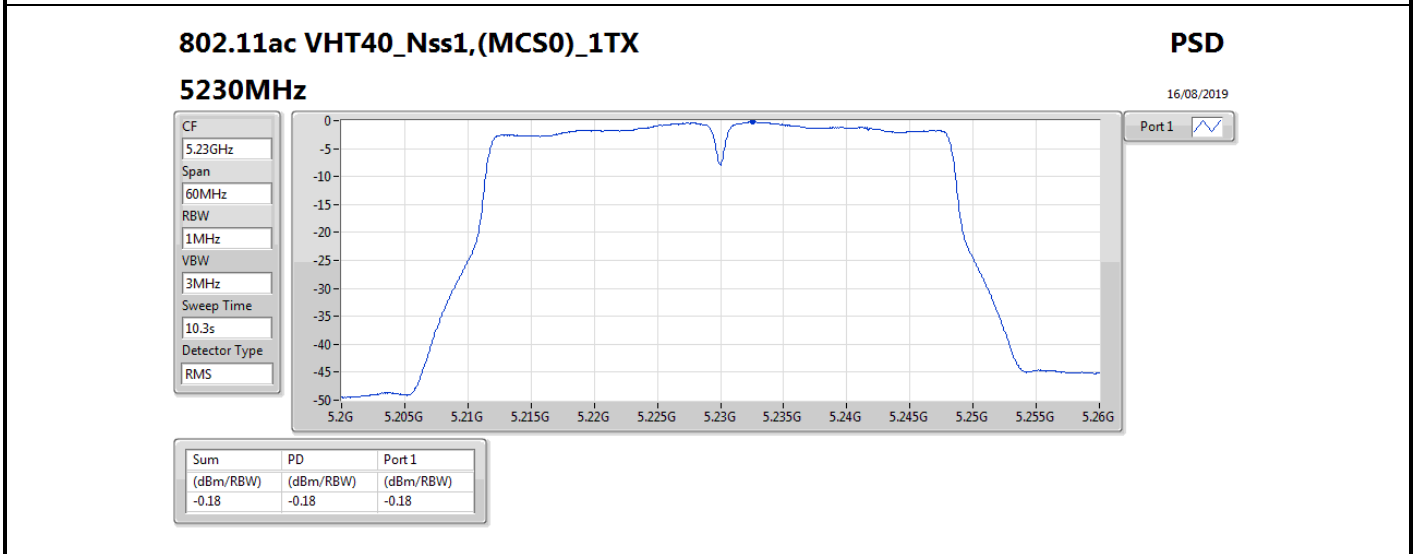
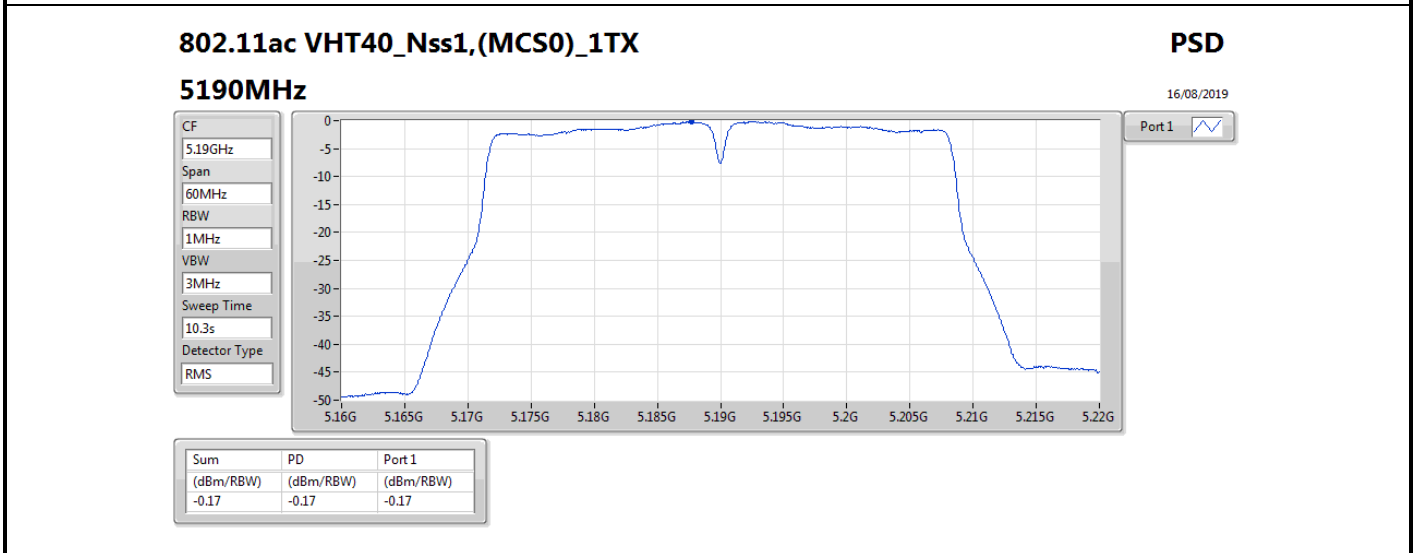
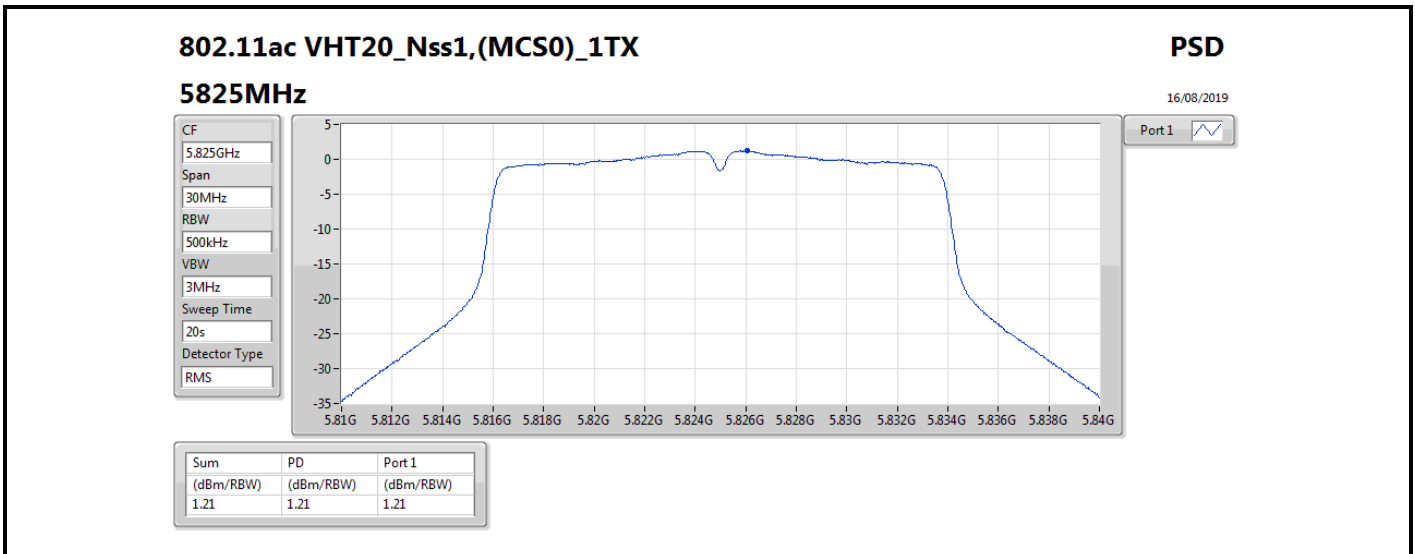



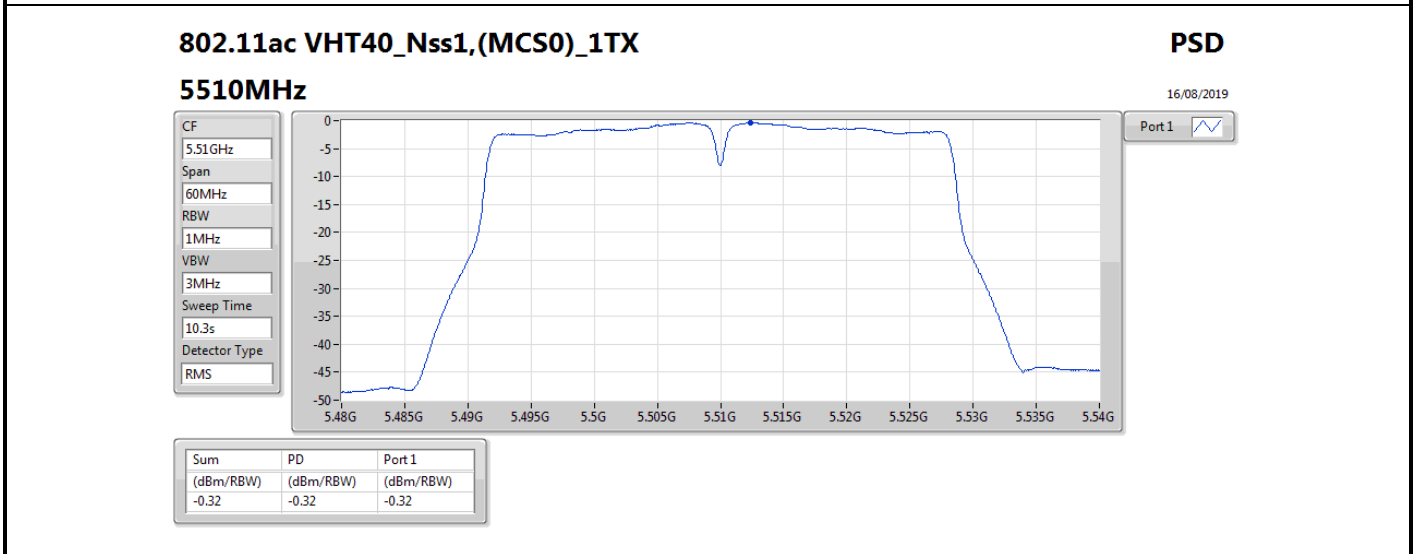
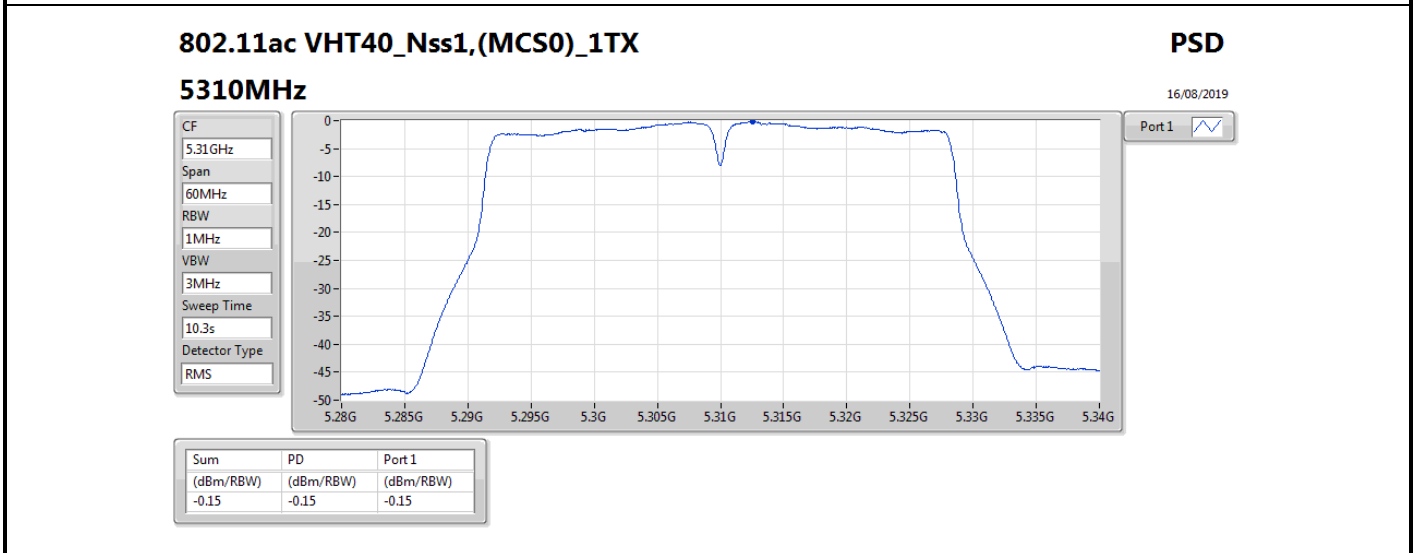
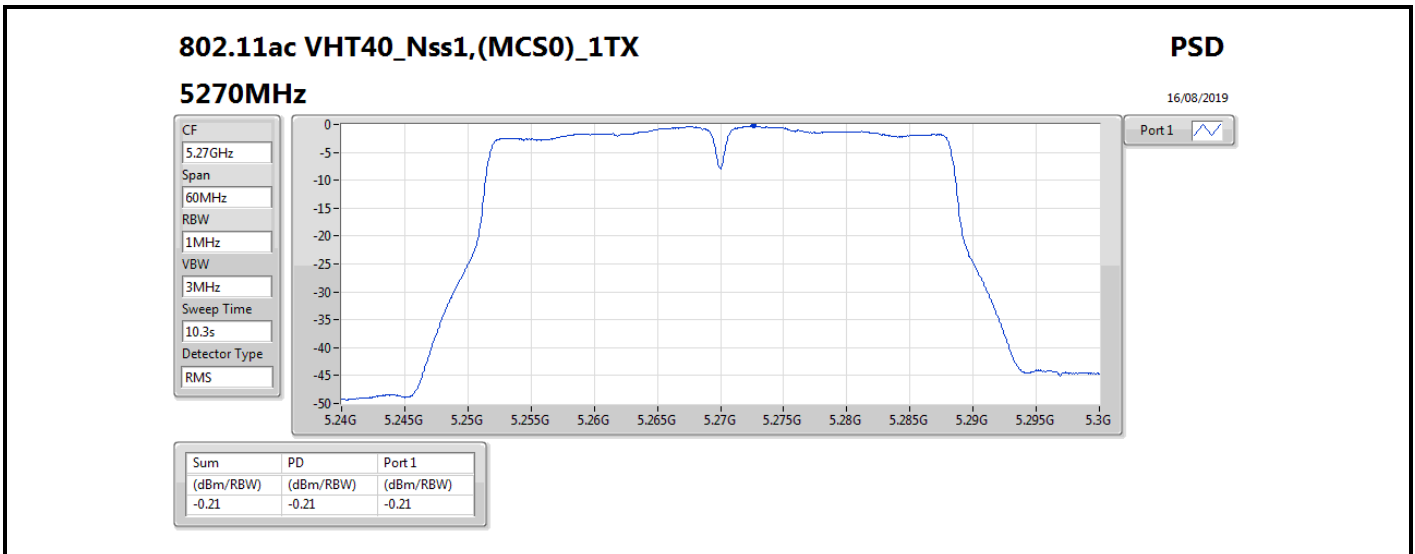

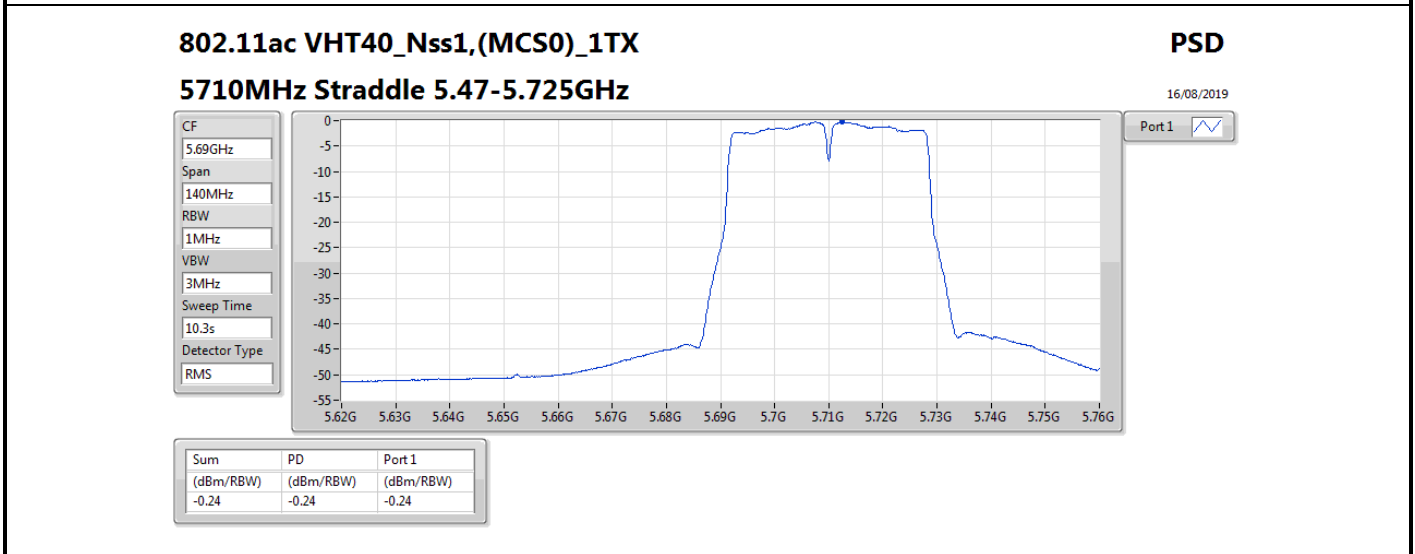
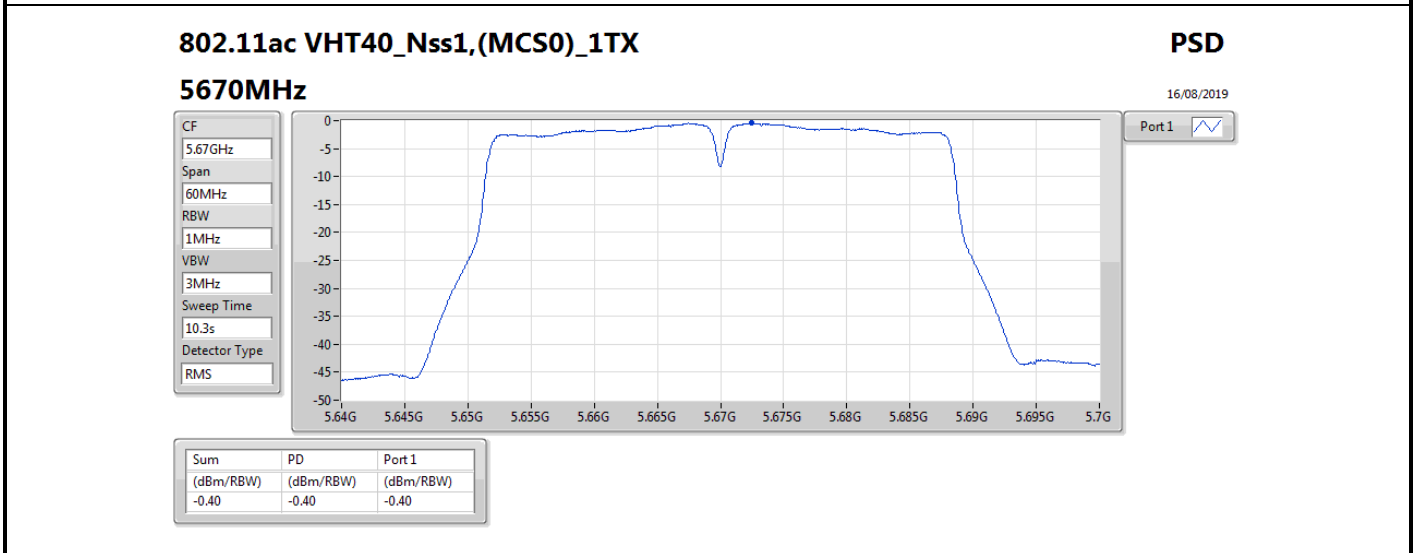
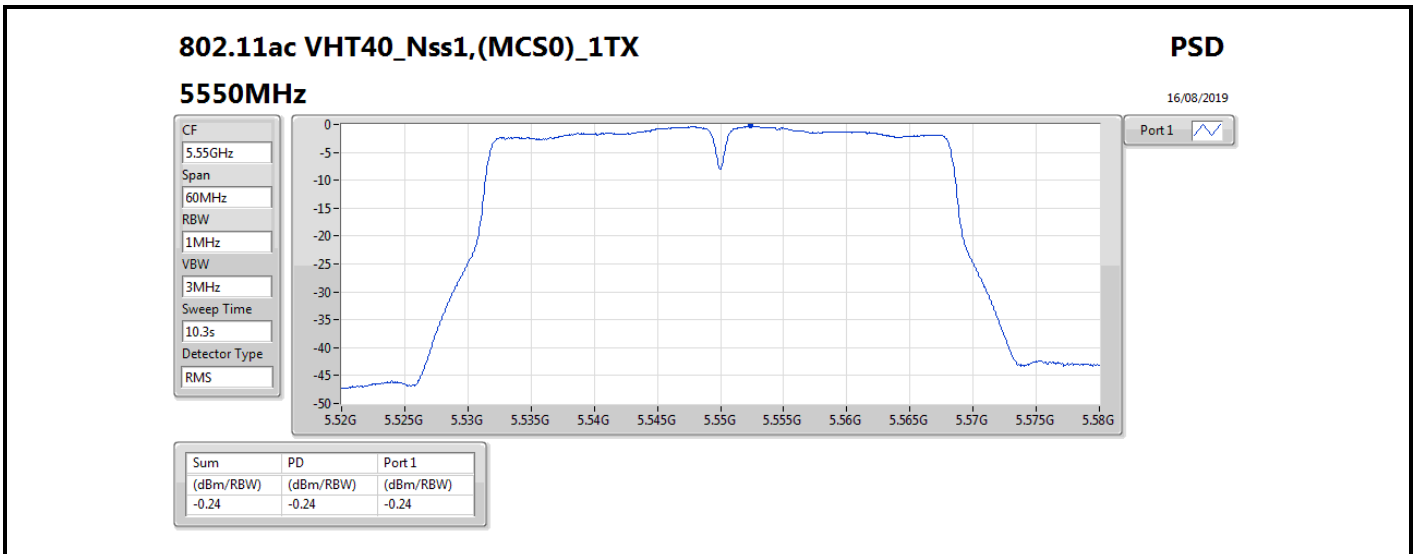

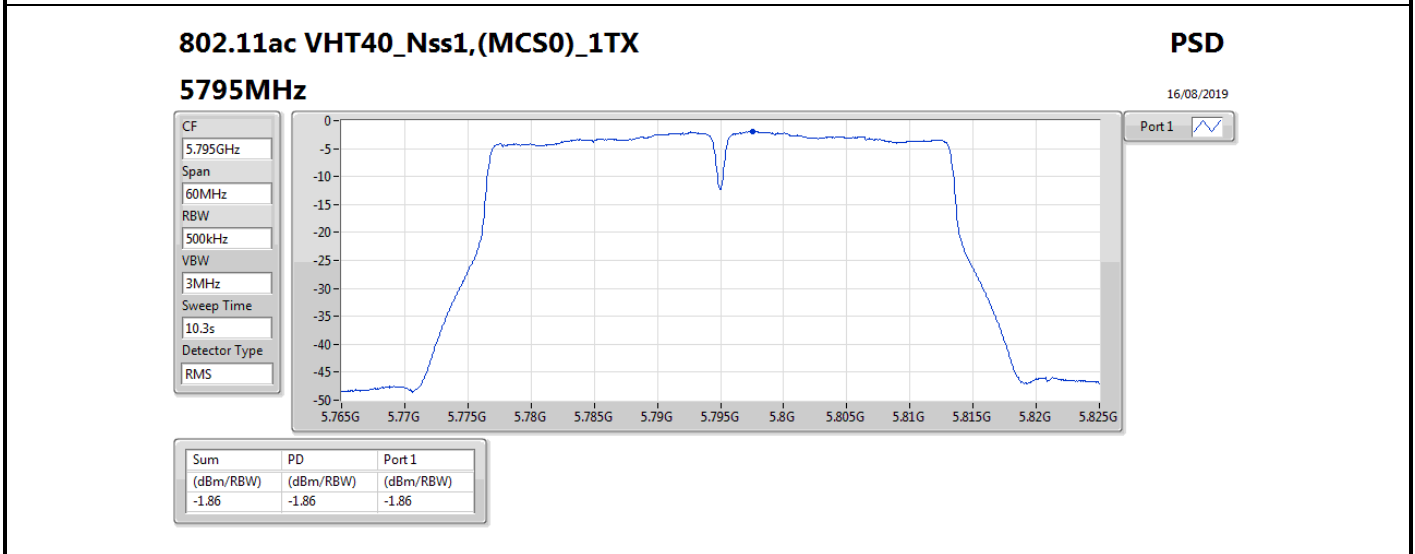
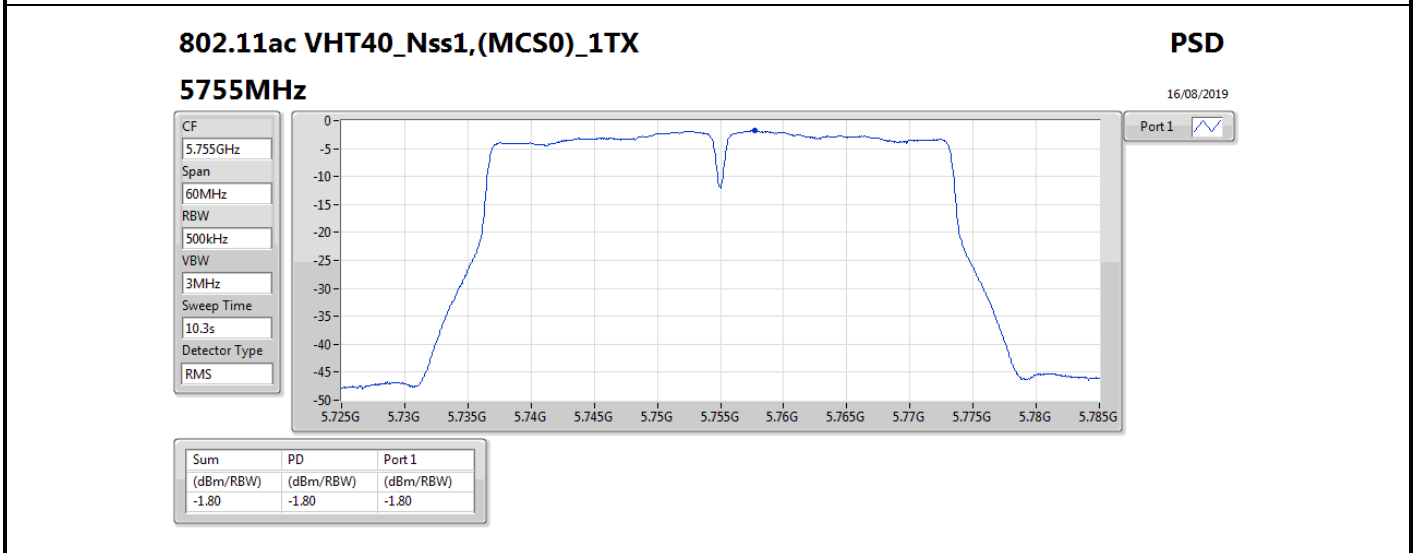
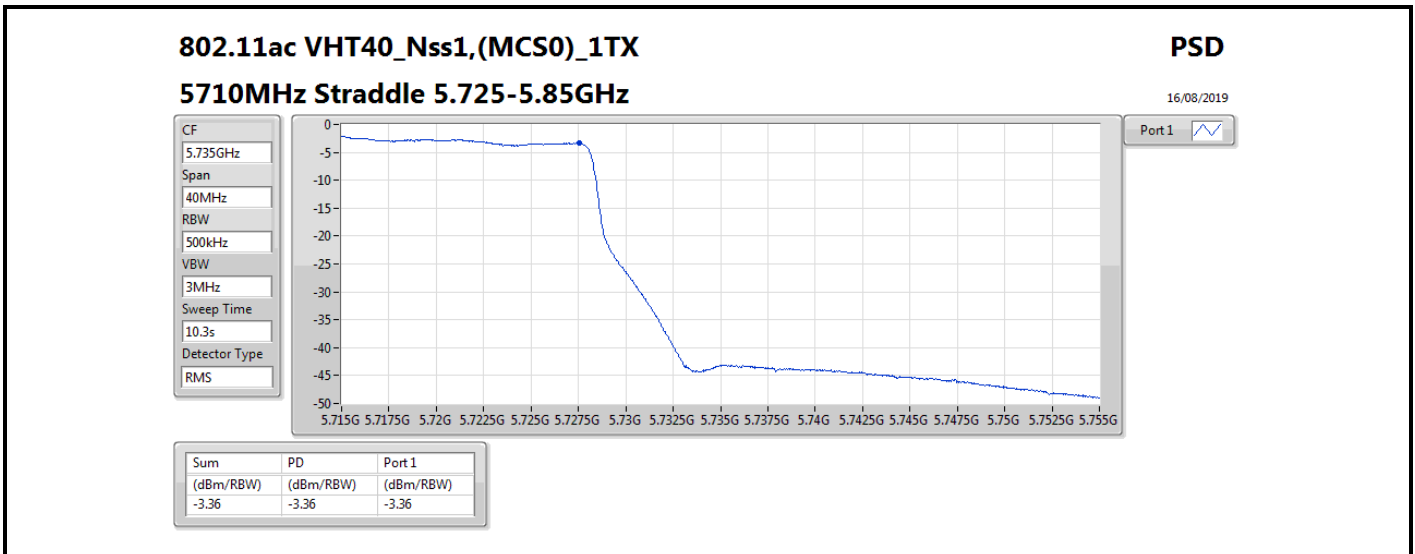

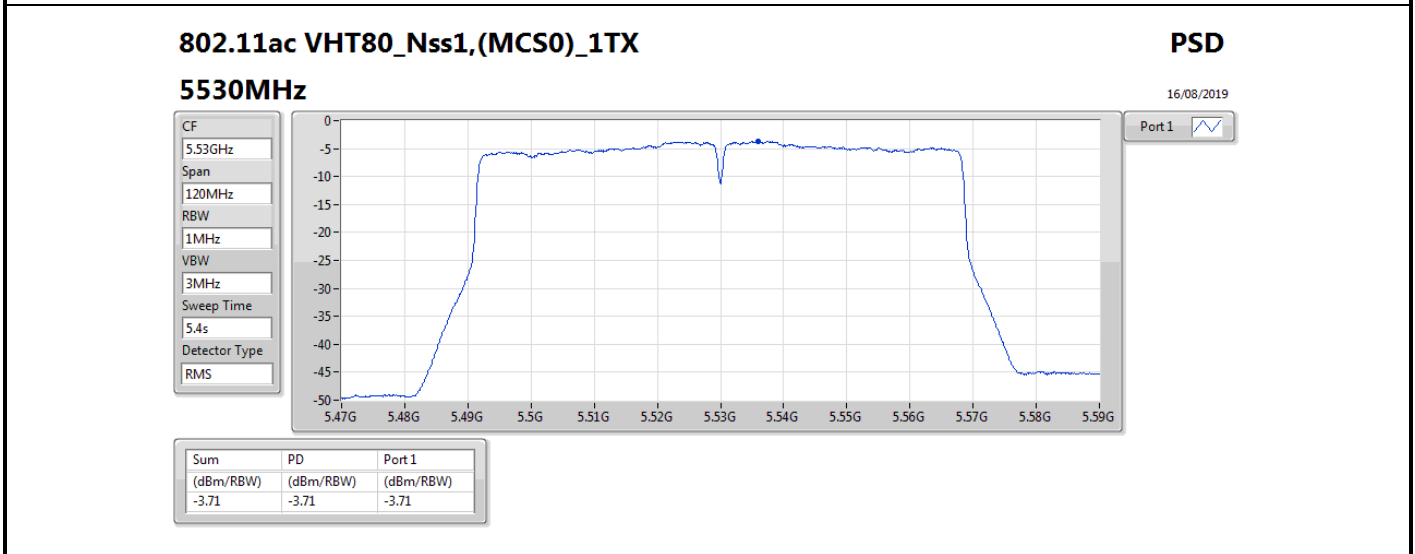
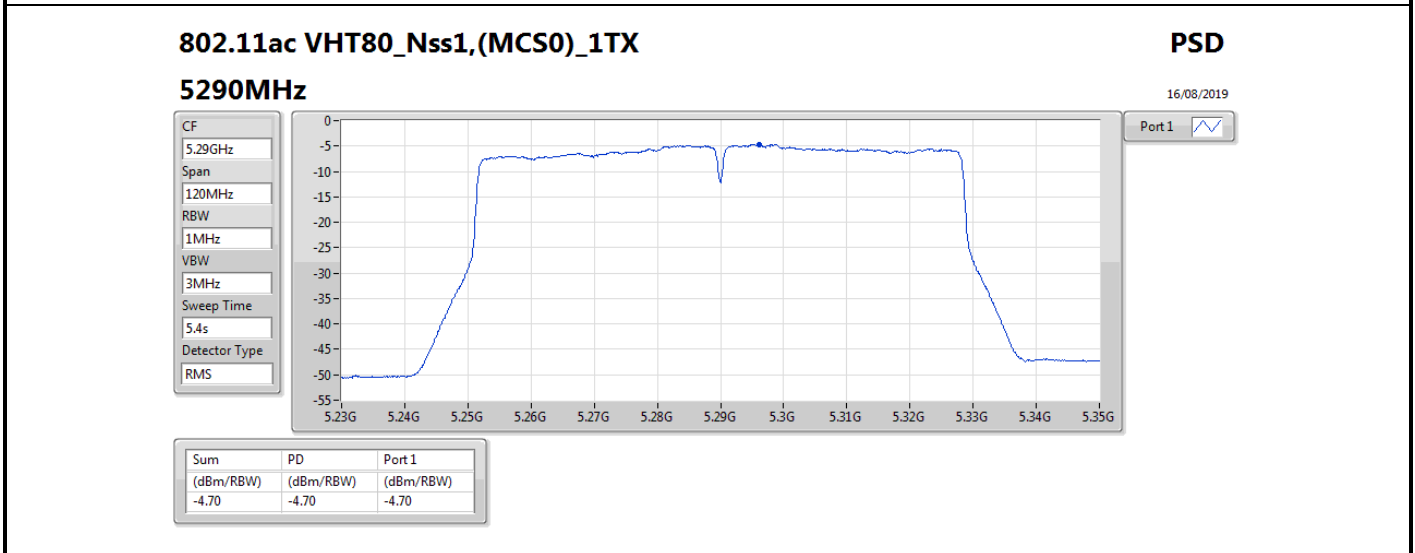
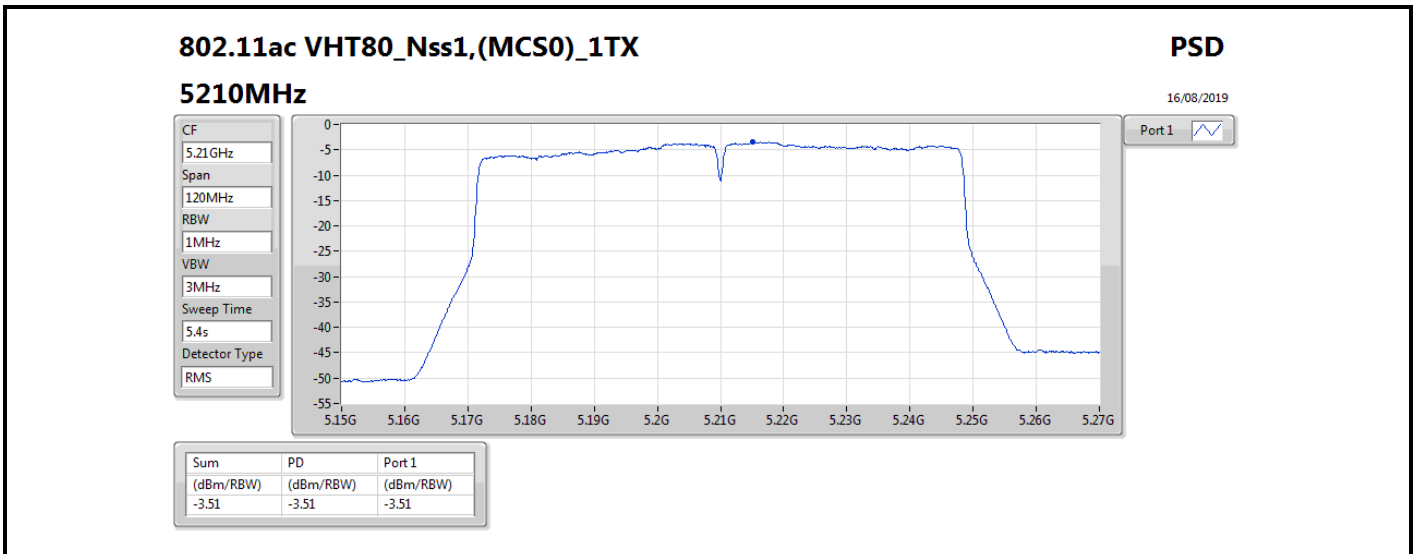

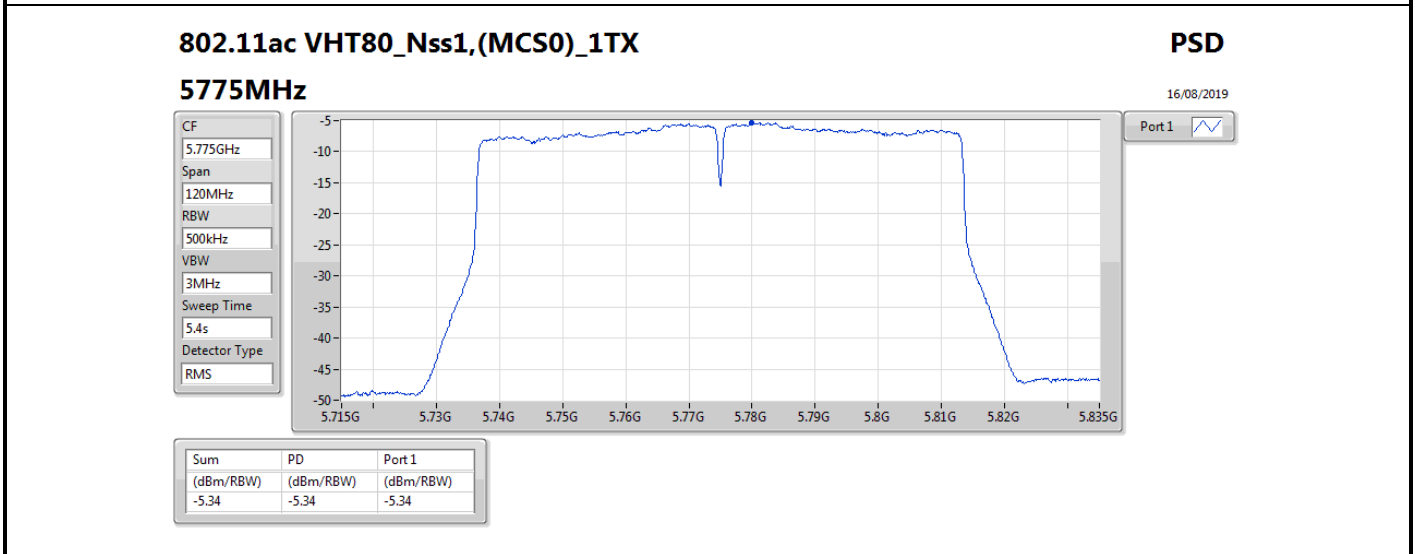
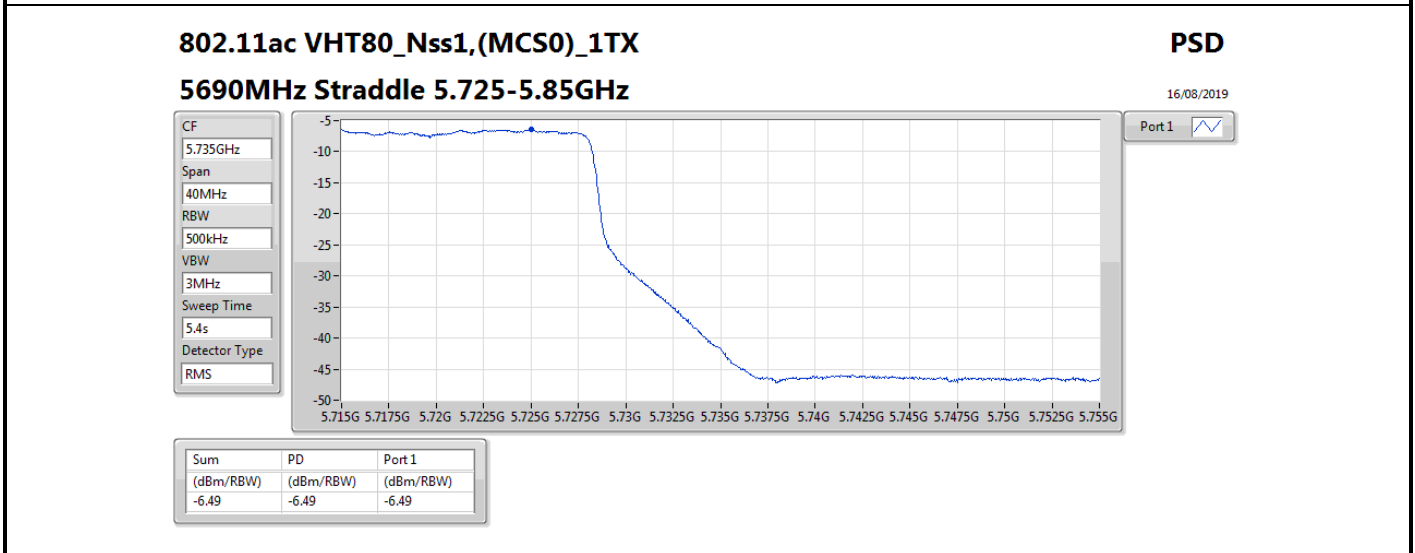
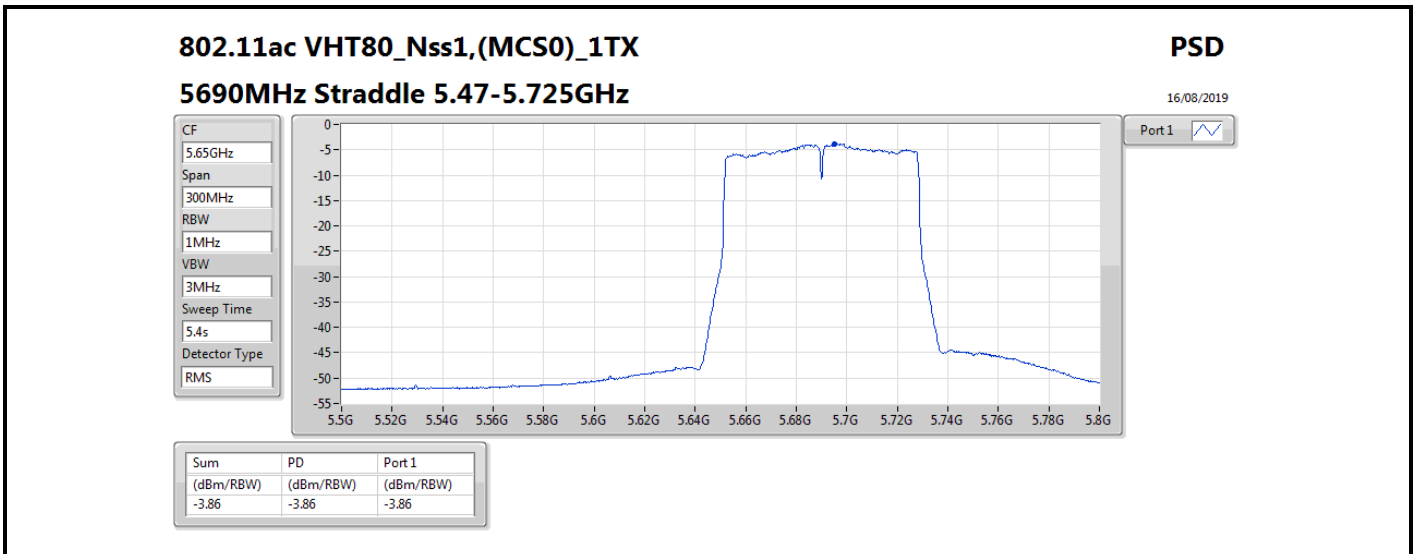



Summary

Mode	Result	Type	Freq (Hz)	Level (dBuV/m)	Limit (dBuV/m)	Margin (dB)	Dist (m)	Condition	Azimuth (°)	Height (m)	Comments
5.725-5.85GHz	-	-	-	-	-	-	-	-	-	-	-
802.11ac VHT80_Nss1,(MCS0)_1TX	Pass	PK	30M	36.54	40.00	-3.46	3	Vertical	360	1.00	-



Result

Mode	Result	Type	Freq (Hz)	Level (dBuV/m)	Limit (dBuV/m)	Margin (dB)	Dist (m)	Condition	Azimuth (°)	Height (m)	Comments
802.11ac VHT80_Nss1,(MCS0)_1TX	-	-	-	-	-	-	-	-	-	-	-
5775MHz	Pass	PK	30M	36.54	40.00	-3.46	3	Vertical	360	1.00	-
5775MHz	Pass	PK	125.06M	31.93	43.50	-11.57	3	Vertical	360	1.00	-
5775MHz	Pass	PK	243.4M	35.70	46.00	-10.30	3	Vertical	360	1.00	-
5775MHz	Pass	PK	299.66M	37.66	46.00	-8.34	3	Vertical	360	1.00	-
5775MHz	Pass	PK	363.68M	29.76	46.00	-16.24	3	Vertical	360	1.00	-
5775MHz	Pass	PK	485.9M	29.17	46.00	-16.83	3	Vertical	360	1.00	-
5775MHz	Pass	PK	30M	23.19	40.00	-16.81	3	Horizontal	0	1.00	-
5775MHz	Pass	PK	82.38M	27.17	40.00	-12.83	3	Horizontal	0	1.00	-
5775MHz	Pass	PK	125.06M	34.62	43.50	-8.88	3	Horizontal	0	1.00	-
5775MHz	Pass	PK	251.16M	37.54	46.00	-8.46	3	Horizontal	0	1.00	-
5775MHz	Pass	PK	278.32M	35.58	46.00	-10.42	3	Horizontal	0	1.00	-
5775MHz	Pass	PK	305.48M	35.65	46.00	-10.35	3	Horizontal	0	1.00	-

802.11ac VHT80\_Nss1,(MCS0)\_1TX

14/08/2019

5775MHz\_Adapter

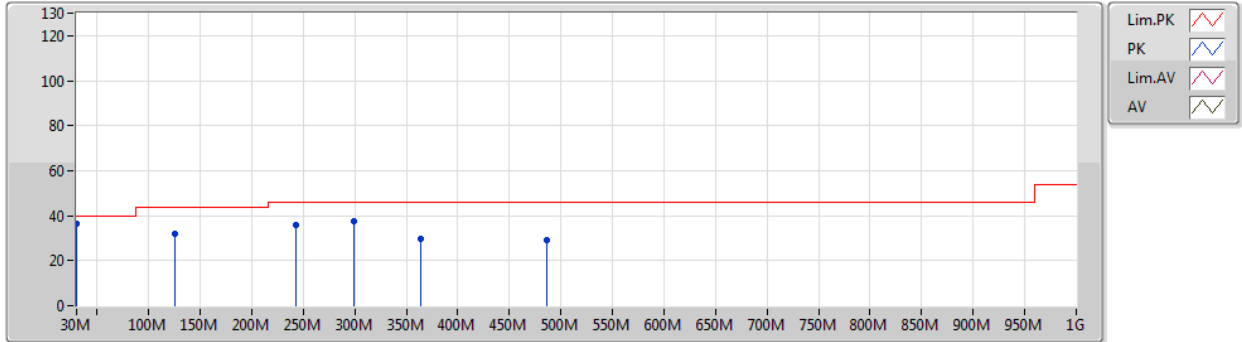

Type	Freq (Hz)	Level (dBuV/m)	Limit (dBuV/m)	Margin (dB)	Factor (dB)	Dist (m)	Condition	Azimuth (°)	Height (m)	Comment	Raw (dBuV)	AF (dB)	CL (dB)	PA (dB)
PK	30M	36.54	40.00	-3.46	-13.24	3	Vertical	360	1.00	-	49.78	23.63	0.48	37.35
PK	125.06M	31.93	43.50	-11.57	-19.00	3	Vertical	360	1.00	-	50.93	16.76	0.91	36.67
PK	243.4M	35.70	46.00	-10.30	-18.09	3	Vertical	360	1.00	-	53.79	17.04	1.28	36.41
PK	299.66M	37.66	46.00	-8.34	-16.67	3	Vertical	360	1.00	-	54.33	18.37	1.44	36.48
PK	363.68M	29.76	46.00	-16.24	-15.02	3	Vertical	360	1.00	-	44.78	19.95	1.61	36.58
PK	485.9M	29.17	46.00	-16.83	-12.02	3	Vertical	360	1.00	-	41.19	22.99	1.87	36.88



802.11ac VHT80\_Nss1,(MCS0)\_1TX

14/08/2019

5775MHz\_Adapter

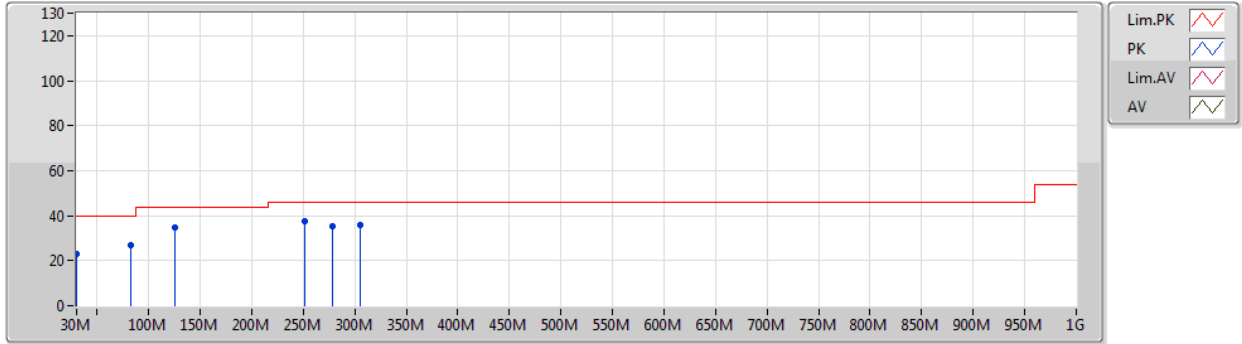

Type	Freq (Hz)	Level (dBuV/m)	Limit (dBuV/m)	Margin (dB)	Factor (dB)	Dist (m)	Condition	Azimuth (°)	Height (m)	Comment	Raw (dBuV)	AF (dB)	CL (dB)	PA (dB)
PK	30M	23.19	40.00	-16.81	-13.24	3	Horizontal	0	1.00	-	36.43	23.63	0.48	37.35
PK	82.38M	27.17	40.00	-12.83	-23.42	3	Horizontal	0	1.00	-	50.59	12.76	0.74	36.92
PK	125.06M	34.62	43.50	-8.88	-19.00	3	Horizontal	0	1.00	-	53.62	16.76	0.91	36.67
PK	251.16M	37.54	46.00	-8.46	-16.94	3	Horizontal	0	1.00	-	54.48	18.19	1.29	36.42
PK	278.32M	35.58	46.00	-10.42	-16.95	3	Horizontal	0	1.00	-	52.53	18.14	1.37	36.46
PK	305.48M	35.65	46.00	-10.35	-16.58	3	Horizontal	0	1.00	-	52.23	18.45	1.46	36.49



Summary

Mode	Result	Type	Freq (Hz)	Level (dBuV/m)	Limit (dBuV/m)	Margin (dB)	Dist (m)	Condition	Azimuth (°)	Height (m)	Comments
5.15-5.25GHz	-	-	-	-	-	-	-	-	-	-	-
802.11a_Nss1,(6Mbps)_1TX	Pass	AV	5.15G	51.79	54.00	-2.21	3	Horizontal	175	2.68	-
802.11ac VHT20_Nss1,(MCS0)_1TX	Pass	AV	5.15G	51.53	54.00	-2.47	3	Vertical	161	2.36	-
802.11ac VHT40_Nss1,(MCS0)_1TX	Pass	AV	5.15G	52.26	54.00	-1.74	3	Vertical	162	1.01	-
802.11ac VHT80_Nss1,(MCS0)_1TX	Pass	AV	5.149G	52.35	54.00	-1.65	3	Vertical	192	1.18	-
5.25-5.35GHz	-	-	-	-	-	-	-	-	-	-	-
802.11a_Nss1,(6Mbps)_1TX	Pass	AV	5.3502G	52.97	54.00	-1.03	3	Vertical	164	1.00	-
802.11ac VHT20_Nss1,(MCS0)_1TX	Pass	AV	5.35G	51.90	54.00	-2.10	3	Vertical	170	2.40	-
802.11ac VHT40_Nss1,(MCS0)_1TX	Pass	AV	5.35G	51.78	54.00	-2.22	3	Vertical	163	1.12	-
802.11ac VHT80_Nss1,(MCS0)_1TX	Pass	AV	5.35G	52.16	54.00	-1.84	3	Horizontal	134	2.31	-
5.47-5.725GHz	-	-	-	-	-	-	-	-	-	-	-
802.11a_Nss1,(6Mbps)_1TX	Pass	PK	5.726G	65.94	68.20	-2.26	3	Vertical	186	2.38	-
802.11ac VHT20_Nss1,(MCS0)_1TX	Pass	PK	5.4692G	66.50	68.20	-1.70	3	Vertical	174	1.67	-
802.11ac VHT40_Nss1,(MCS0)_1TX	Pass	PK	5.7282G	66.84	68.20	-1.36	3	Vertical	181	2.43	-
802.11ac VHT80_Nss1,(MCS0)_1TX	Pass	AV	5.46G	52.04	54.00	-1.96	3	Horizontal	129	2.48	-
5.725-5.85GHz	-	-	-	-	-	-	-	-	-	-	-
802.11a_Nss1,(6Mbps)_1TX	Pass	AV	11.65804G	43.96	54.00	-10.04	3	Vertical	98	2.25	-
802.11ac VHT20_Nss1,(MCS0)_1TX	Pass	AV	11.65072G	44.03	54.00	-9.97	3	Horizontal	326	1.91	-
802.11ac VHT40_Nss1,(MCS0)_1TX	Pass	PK	5.653G	66.79	70.42	-3.63	3	Vertical	175	1.50	-
802.11ac VHT80_Nss1,(MCS0)_1TX	Pass	PK	5.6502G	66.96	68.35	-1.39	3	Vertical	188	2.19	-



Result

Mode	Result	Type	Freq (Hz)	Level (dBuV/m)	Limit (dBuV/m)	Margin (dB)	Dist (m)	Condition	Azimuth (°)	Height (m)	Comments
802.11a_Nss1,(6Mbps)_1TX	-	-	-	-	-	-	-	-	-	-	-
5180MHz	Pass	AV	5.1498G	50.61	54.00	-3.39	3	Vertical	79	2.88	-
5180MHz	Pass	AV	5.1812G	100.06	Inf	-Inf	3	Vertical	79	2.88	-
5180MHz	Pass	PK	5.1498G	65.08	74.00	-8.92	3	Vertical	79	2.88	-
5180MHz	Pass	PK	5.1812G	109.59	Inf	-Inf	3	Vertical	79	2.88	-
5180MHz	Pass	AV	5.15G	51.79	54.00	-2.21	3	Horizontal	175	2.68	-
5180MHz	Pass	AV	5.179G	101.12	Inf	-Inf	3	Horizontal	175	2.68	-
5180MHz	Pass	PK	5.1488G	65.94	74.00	-8.06	3	Horizontal	175	2.68	-
5180MHz	Pass	PK	5.1816G	110.70	Inf	-Inf	3	Horizontal	175	2.68	-
5180MHz	Pass	PK	10.37464G	56.07	68.20	-12.13	3	Vertical	152	1.32	-
5180MHz	Pass	PK	10.36008G	55.81	68.20	-12.39	3	Horizontal	195	1.87	-
5200MHz	Pass	AV	5.15G	49.38	54.00	-4.62	3	Vertical	170	1.05	-
5200MHz	Pass	AV	5.1988G	105.03	Inf	-Inf	3	Vertical	170	1.05	-
5200MHz	Pass	PK	5.1496G	62.68	74.00	-11.32	3	Vertical	170	1.05	-
5200MHz	Pass	PK	5.1992G	114.46	Inf	-Inf	3	Vertical	170	1.05	-
5200MHz	Pass	AV	5.15G	45.52	54.00	-8.48	3	Horizontal	52	1.08	-
5200MHz	Pass	AV	5.1984G	99.84	Inf	-Inf	3	Horizontal	52	1.08	-
5200MHz	Pass	PK	5.1496G	58.12	74.00	-15.88	3	Horizontal	52	1.08	-
5200MHz	Pass	PK	5.2036G	110.44	Inf	-Inf	3	Horizontal	52	1.08	-
5200MHz	Pass	PK	10.40114G	57.58	68.20	-10.62	3	Vertical	182	1.34	-
5200MHz	Pass	PK	10.40026G	56.15	68.20	-12.05	3	Horizontal	167	2.01	-
5240MHz	Pass	AV	5.15G	43.45	54.00	-10.55	3	Vertical	63	2.91	-
5240MHz	Pass	AV	5.2406G	100.75	Inf	-Inf	3	Vertical	63	2.91	-
5240MHz	Pass	AV	5.3774G	41.55	54.00	-12.45	3	Vertical	63	2.91	-
5240MHz	Pass	PK	5.1374G	55.37	74.00	-18.63	3	Vertical	63	2.91	-
5240MHz	Pass	PK	5.2418G	111.60	Inf	-Inf	3	Vertical	63	2.91	-
5240MHz	Pass	PK	5.3582G	53.66	74.00	-20.34	3	Vertical	63	2.91	-
5240MHz	Pass	AV	5.1482G	44.27	54.00	-9.73	3	Horizontal	135	2.35	-
5240MHz	Pass	AV	5.2388G	104.46	Inf	-Inf	3	Horizontal	135	2.35	-
5240MHz	Pass	AV	5.3522G	41.83	54.00	-12.17	3	Horizontal	135	2.35	-
5240MHz	Pass	PK	5.15G	57.28	74.00	-16.72	3	Horizontal	135	2.35	-
5240MHz	Pass	PK	5.2418G	115.57	Inf	-Inf	3	Horizontal	135	2.35	-
5240MHz	Pass	PK	5.351G	56.11	74.00	-17.89	3	Horizontal	135	2.35	-
5240MHz	Pass	PK	10.4809G	56.71	68.20	-11.49	3	Vertical	155	1.00	-
5240MHz	Pass	PK	10.47914G	56.94	68.20	-11.26	3	Horizontal	255	1.92	-
5260MHz	Pass	AV	5.1388G	43.12	54.00	-10.88	3	Vertical	155	1.00	-
5260MHz	Pass	AV	5.2612G	103.10	Inf	-Inf	3	Vertical	155	1.00	-
5260MHz	Pass	AV	5.3506G	42.74	54.00	-11.26	3	Vertical	155	1.00	-
5260MHz	Pass	PK	5.1328G	56.07	74.00	-17.93	3	Vertical	155	1.00	-
5260MHz	Pass	PK	5.2606G	113.06	Inf	-Inf	3	Vertical	155	1.00	-
5260MHz	Pass	PK	5.3554G	55.73	74.00	-18.27	3	Vertical	155	1.00	-
5260MHz	Pass	AV	5.122G	43.11	54.00	-10.89	3	Horizontal	58	1.01	-
5260MHz	Pass	AV	5.2588G	101.10	Inf	-Inf	3	Horizontal	58	1.01	-
5260MHz	Pass	AV	5.3512G	42.20	54.00	-11.80	3	Horizontal	58	1.01	-
5260MHz	Pass	PK	5.1124G	55.70	74.00	-18.30	3	Horizontal	58	1.01	-
5260MHz	Pass	PK	5.2612G	111.43	Inf	-Inf	3	Horizontal	58	1.01	-
5260MHz	Pass	PK	5.3614G	55.51	74.00	-18.49	3	Horizontal	58	1.01	-
5260MHz	Pass	PK	10.5113G	56.26	68.20	-11.94	3	Vertical	1	2.42	-



Mode	Result	Type	Freq (Hz)	Level (dBuV/m)	Limit (dBuV/m)	Margin (dB)	Dist (m)	Condition	Azimuth (°)	Height (m)	Comments
5260MHz	Pass	PK	10.52942G	56.38	68.20	-11.82	3	Horizontal	7	2.33	-
5300MHz	Pass	AV	5.2988G	103.65	Inf	-Inf	3	Vertical	164	1.00	-
5300MHz	Pass	AV	5.35G	50.74	54.00	-3.26	3	Vertical	164	1.00	-
5300MHz	Pass	PK	5.2988G	113.43	Inf	-Inf	3	Vertical	164	1.00	-
5300MHz	Pass	PK	5.3544G	63.44	74.00	-10.56	3	Vertical	164	1.00	-
5300MHz	Pass	AV	5.2992G	99.10	Inf	-Inf	3	Horizontal	53	1.00	-
5300MHz	Pass	AV	5.35G	46.66	54.00	-7.34	3	Horizontal	53	1.00	-
5300MHz	Pass	PK	5.298G	109.15	Inf	-Inf	3	Horizontal	53	1.00	-
5300MHz	Pass	PK	5.3516G	60.18	74.00	-13.82	3	Horizontal	53	1.00	-
5300MHz	Pass	PK	10.59076G	56.29	68.20	-11.91	3	Vertical	106	1.03	-
5300MHz	Pass	PK	10.60606G	56.22	74.00	-17.78	3	Horizontal	66	1.86	-
5320MHz	Pass	AV	5.3212G	102.01	Inf	-Inf	3	Vertical	164	1.00	-
5320MHz	Pass	AV	5.3502G	52.97	54.00	-1.03	3	Vertical	164	1.00	-
5320MHz	Pass	PK	5.3218G	111.54	Inf	-Inf	3	Vertical	164	1.00	-
5320MHz	Pass	PK	5.3508G	66.35	74.00	-7.65	3	Vertical	164	1.00	-
5320MHz	Pass	AV	5.3212G	97.14	Inf	-Inf	3	Horizontal	54	1.01	-
5320MHz	Pass	AV	5.35G	48.36	54.00	-5.64	3	Horizontal	54	1.01	-
5320MHz	Pass	PK	5.3178G	106.90	Inf	-Inf	3	Horizontal	54	1.01	-
5320MHz	Pass	PK	5.35G	62.16	74.00	-11.84	3	Horizontal	54	1.01	-
5320MHz	Pass	AV	10.62608G	43.79	54.00	-10.21	3	Vertical	142	2.48	-
5320MHz	Pass	PK	10.62542G	56.71	74.00	-17.29	3	Vertical	142	2.48	-
5320MHz	Pass	AV	10.64324G	43.60	54.00	-10.40	3	Horizontal	20	2.14	-
5320MHz	Pass	PK	10.63028G	56.33	74.00	-17.67	3	Horizontal	20	2.14	-
5500MHz	Pass	AV	5.46G	47.71	54.00	-6.29	3	Vertical	177	1.49	-
5500MHz	Pass	AV	5.501G	101.33	Inf	-Inf	3	Vertical	177	1.49	-
5500MHz	Pass	PK	5.4686G	64.80	68.20	-3.40	3	Vertical	177	1.49	-
5500MHz	Pass	PK	5.4982G	111.15	Inf	-Inf	3	Vertical	177	1.49	-
5500MHz	Pass	AV	5.4598G	43.75	54.00	-10.25	3	Horizontal	43	1.20	-
5500MHz	Pass	AV	5.5012G	95.59	Inf	-Inf	3	Horizontal	43	1.20	-
5500MHz	Pass	PK	5.4694G	58.26	68.20	-9.94	3	Horizontal	43	1.20	-
5500MHz	Pass	PK	5.5008G	105.14	Inf	-Inf	3	Horizontal	43	1.20	-
5500MHz	Pass	AV	11.00048G	44.46	54.00	-9.54	3	Vertical	181	1.63	-
5500MHz	Pass	PK	10.99502G	57.13	74.00	-16.87	3	Vertical	181	1.63	-
5500MHz	Pass	AV	11.01356G	44.27	54.00	-9.73	3	Horizontal	160	1.33	-
5500MHz	Pass	PK	10.98926G	57.08	74.00	-16.92	3	Horizontal	160	1.33	-
5580MHz	Pass	AV	5.445G	41.54	54.00	-12.46	3	Vertical	178	2.38	-
5580MHz	Pass	AV	5.5812G	103.37	Inf	-Inf	3	Vertical	178	2.38	-
5580MHz	Pass	PK	5.463G	54.09	68.20	-14.11	3	Vertical	178	2.38	-
5580MHz	Pass	PK	5.5806G	114.42	Inf	-Inf	3	Vertical	178	2.38	-
5580MHz	Pass	PK	5.7282G	53.94	68.20	-14.26	3	Vertical	178	2.38	-
5580MHz	Pass	AV	5.46G	41.71	54.00	-12.29	3	Horizontal	130	2.45	-
5580MHz	Pass	AV	5.5812G	105.76	Inf	-Inf	3	Horizontal	130	2.45	-
5580MHz	Pass	PK	5.4636G	54.76	68.20	-13.44	3	Horizontal	130	2.45	-
5580MHz	Pass	PK	5.5806G	116.37	Inf	-Inf	3	Horizontal	130	2.45	-
5580MHz	Pass	PK	5.7252G	54.88	68.20	-13.32	3	Horizontal	130	2.45	-
5580MHz	Pass	AV	11.16174G	44.51	54.00	-9.49	3	Vertical	149	2.04	-
5580MHz	Pass	PK	11.16942G	57.18	74.00	-16.82	3	Vertical	149	2.04	-
5580MHz	Pass	AV	11.15184G	44.67	54.00	-9.33	3	Horizontal	140	1.35	-
5580MHz	Pass	PK	11.1747G	57.64	74.00	-16.36	3	Horizontal	140	1.35	-