



Excellence in Compliance Testing

---

## **Certification Exhibit**

**FCC ID: U4A-SCYPROX2  
IC: 6982A-SCYPROX2**

**FCC Rule Part: 15.225  
IC Radio Standards Specification: RSS-210**

**ACS Report Number: 09-0176 - 15C**

Manufacturer: Assa Abloy, Inc.  
Model: Bored/Exits, Mortise

## **Manual – Bored/Exits**

# Installation Instructions

## Harmony Series H2

### 8600, 8800, 8900 Exits

**SARGENT**<sup>®</sup>

---

**ASSA ABLOY**

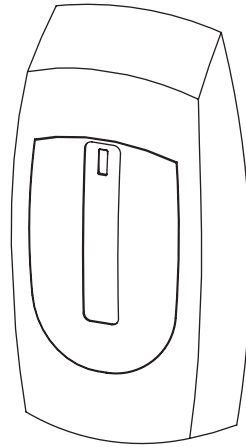

A8029A  
06/09

# Table of Contents

- 1 Warning .....2**
- 2 General Description .....3**
- 3 Hardware Specifications .....3**
- 4 Electronics Specifications .....3**
- 5 H2 8600 Concealed Vertical Rod (CVR) Exit Device.....4**
- 6 H2 8800 Rim Exit Device.....11**
- 7 H2 8900 Mortise Exit Device.....17**
- 8 Wiring Diagrams .....24**
- 9 Mechanical Operational Check .....28**
- 10 Electrical Operational Check.....28**

## 1 Warning

Warning: Changes or modifications to this unit not expressly approved by the party responsible for compliance could void the user’s authority to operate the equipment.

This device complies with Part 15 of the FCC Rules. Operation is subject to the following two conditions: (1) this device may not cause harmful interference, and (2) this device must accept any interference received, including interference that may cause undesired operation.

Note: This equipment has been tested and found to comply with the limits for a Class B digital device, pursuant to Part 15 of the FCC Rules. These limits are designed to provide reasonable protection against harmful interference in a residential installation.

This equipment generates, uses and can radiate radio frequency energy and if not installed and used in accordance with the instructions, may cause harmful interference to radio communications. However, there is no guarantee that the interference will not occur in a particular installation. If this equipment does cause harmful interference to radio or television reception, which can be determined by turning the equipment off and on, the user is encouraged to try to correct the interference by one or more of the following measures:

- Reorient or relocate the receiving antenna
- Increase the separation between the equipment and receiver
- Connect the equipment into an outlet on a circuit different from that to which the receiver is connected
- Consult the dealer or an experienced technician for help

The term “IC:” before the radio certification number only signifies that Industry Canada technical specifications were met. This Class B digital apparatus meets all requirements of the Canadian Interference Causing Equipment Regulations. Operation is subject to the following two conditions: (1) this device may not cause harmful interference, and (2) this device must accept any interference received, including interference that may cause undesired operation.

Cet appareillage numérique de la classe B répond à toutes les exigences de l’interférence canadienne causant des règlements d’équipement. L’opération est sujette aux deux conditions suivantes: (1) ce dispositif peut ne pas causer l’interférence nocive, et (2) ce dispositif doit accepter n’importe quelle interférence reçue, y compris l’interférence qui peut causer l’opération peu désirée.



Observe precautions for handling electrostatic sensitive devices.

## 2 General Description

The SARGENT Harmony H2 series exit devices (8600, 8800, 8900) are designed to interface with existing Wiegand Electronic Access Control (EAC) panels. The reader requires 12 or 24VDC for power and is compatible with HID iCLASS® 13.56MHz technology. The Harmony series technology is backed by SARGENT Grade 1 mechanical hardware. All exits include RX (request to exit) monitoring in the rail and an external Door Position Switch (DPS) for door position monitoring. Harmony is available as 12VDC or 24VDC solenoid operated ET trim. Weatherseal gaskets are also included for exterior door applications. The Harmony H2 iCLASS reader provides visual and audible indicators of lock state (locked/unlocked).

## 3 Hardware Specifications

### All Harmony Exit Devices

- Certified ANSI/BHMA A156.3 Grade 1
- Push bar retracts latch from inside, allowing free egress
- Request-to-Exit (REX) Switch activated by pushing rail
- Outside lever controlled by any 13.56MHz HID iCLASS Wiegand credential
- Fire rated devices available
- UL Listed
- Exit devices furnished for 1-3/4" doors
- Fail safe or fail secure available
- Door Position Switch (DPS, part #3287) supplied to allow for monitoring
- 12VDC/24VDC solenoid-operated ET trim
- EAC Panel wiring to door must be shielded with a drain. Drain terminated at EAC Panel controller

### Harmony 8600 Series Concealed Vertical Rod (CVR)

- Cylinder override available for 8600 CVR with 106 Series Auxiliary Control
- The AFF is 41" for Standard Applications; when a 100 Series Auxiliary Control is used, 38" AFF is recommended to meet local accessibility standards

### Harmony 8800 Series Rim

- Cylinder override available
- Accepts all SARGENT rim cylinders (75/76 functions)
- Key retracts latch (75/76 functions)
- Latch – 3/4" throw, stainless steel

### Harmony 8900 Series Mortise

- Cylinder override available
- Accepts all SARGENT mortise cylinders (75/76 functions)
- Key retracts latch (75/76 functions)
- Latch – 3/4" throw, anti-friction, brass

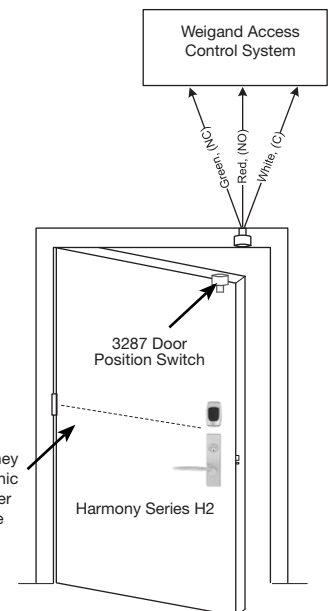

Hardwiring Made Easy®



## 4 Electronics Specifications

### 12VDC System

- Reader Draw = 125mA
- 12VDC Solenoid Draw = 500mA
- Total Current Draw = 625mA

### 24VDC System

- Reader Draw = 125mA
- 24VDC Solenoid Draw = 250mA
- Total Current Draw = 375mA

### Wire Gauge Charts

Total One-Way Length of Wire Run (ft)	Load Current @ 12VDC							
	1/4A	1/2A	3/4A	1A	1-1/4A	1-1/2A	2A	3A
100	20	18	16	14	14	12	12	10
150	18	16	14	12	12	12	10	—
200	16	14	12	12	10	10	—	—
250	16	14	12	10	10	10	—	—
300	16	12	12	10	10	—	—	—
400	14	12	10	—	—	—	—	—
500	14	10	10	—	—	—	—	—
750	12	10	—	—	—	—	—	—
1,000	10	—	—	—	—	—	—	—
1,500	10	—	—	—	—	—	—	—

Total One-Way Length of Wire Run (ft)	Load Current @ 24VDC							
	1/4A	1/2A	3/4A	1A	1-1/4A	1-1/2A	2A	3A
100	24	20	18	18	16	16	14	12
150	22	18	16	16	14	14	12	10
200	20	18	16	14	14	12	12	10
250	18	16	14	14	12	12	12	10
300	18	16	14	12	12	12	10	—
400	18	14	12	12	10	10	—	—
500	16	14	12	10	10	—	—	—
750	14	12	10	10	—	—	—	—
1,000	14	10	10	—	—	—	—	—
1,500	12	10	—	—	—	—	—	—

## 5 Installation Instructions For Harmony Series H2 8600 Concealed Vertical Rod (CVR) Exit Device

### Parts Breakdown

#### Tools Required

- Phillips screw driver (standard size)
- Flat blade screw driver (standard)

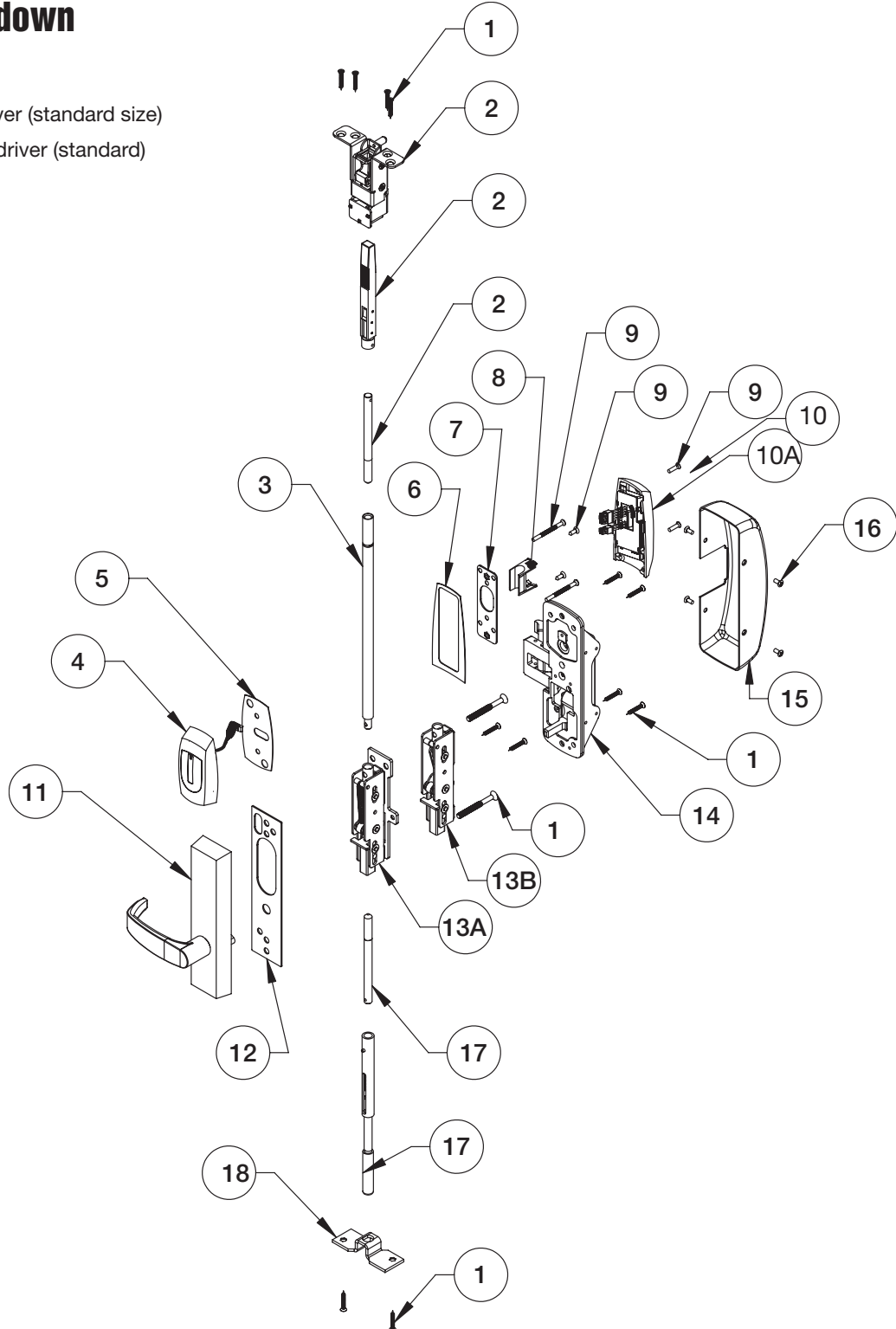

Copyright © 2009 Sargent Manufacturing Company, an ASSA ABLOY Group company. All rights reserved. Reproductions in whole or in part without express written permission of Sargent Manufacturing Company is prohibited.

06/30/09

## Parts Breakdown For Harmony Series H2 8600 (Continued) Shipment Contents

ITEM	PART #	Description	Req.
1	68-3577	Chassis Wood Door (WD) Screw Pack	1
	68-3905	Chassis Metal Door (MD) Screw Pack (not shown)	
2	68-7057	WD 8600 Top Assembly	1
	68-7060	MD/AD 8600 Top Assembly (not shown)	
3	94-0212	Aux Control Rod Adapter	1
4	52-4038	Outside Harmony Escutcheon Assembly	1
5	52-0792	Outside Harmony Gasket	1
6	52-0793	Inside Harmony Gasket	1
7	52-5219	Harmony Inside Escutcheon Mounting Plate	1
8	52-0801	Wire Guide	1
9	52-5236	Screw Pack (Escutcheon)	1
10	68-1581	Inside Harmony Escutcheon	1
10A	52-4036	H2 Controller Assembly	1
11	*Harmony Trim is Ordered as "N1"		1
		N1-773-4 ETL12V Fail Safe	
		N1-773-4 ETL 24V Fail Safe	
		N1-774-4 ETL12V Fail Secure	
		N1-774-4 ETL 24V Fail Secure	
12	52-0263	ET Trim Gasket	1
13A	68-3859	WD Inner Case Assembly	1
13B	68-5067	MD/AD Inner Case Assembly	1
14	68-7241	8600 Chassis LHRB	1
	68-7242	8600 Chassis RHRB (not shown)	
15	68-0407	Chassis Cover	1
16	68-3905	Screw Pack (Rail and Chassis Cover)	1
17	68-0888	MD/WD Bottom Case Assembly	1
17	68-0037	AD Bottom Case Assembly	1
18	3287	DPS Door Position Switch (not shown)	1
19	A8029	Installation Instructions (not shown)	1
20	4621	MD/AD Door Manufacturer Template (not shown)	1
21	4622	Wood Door Manufacturer Template (not shown)	1

### How to Specify ET Trim

How to order without an exit device.

Specify: 7 for 700 Series ET, Function, Suffix, Lever, Finish and handing (e.g., 775-8 ETL x 26D x RHRB).

Note: Suffix requirements are based on type of device to be used:

- 8 suffix is required for 8800, 8500, NB8700, PP, PR and SP8700 devices, except with these functions: 04, 10, 16, 40 and 44.
- 6 suffix is required for all PP, PR, SP, LP, LR and LS devices.
- 4 suffix is required for all 8400, WD, MD and AD 8600 devices.
- No suffix is necessary for all 8900, 8300, 8700 with bottom rod and 8800, 8500, NB8700, PP, PR & SP8700 devices with these functions: 04, 10, 16, 40 and 44.

### Step #1 – Prepare Door

#### A. Verify Hand and Bevel of Door

- Check hand of door. Exit Device may be handed.
- Door should be fitted and hung.
- Verify box label for size of exit device, function and hand.

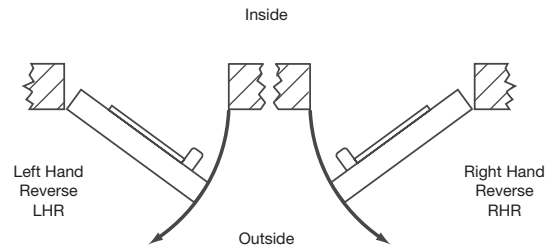

Fig. 1A

#### B. Door Preparation

Prepare door according to appropriate template. If necessary, refer to website, [www.intelligentopenings.com](http://www.intelligentopenings.com):

- Metal door (MD/AD): A7002
    - Templates: 4621 and 4445
  - Wood door (WD): A3937
    - Templates: 4622 and 4431
- Note: Instruction examples show wood door installation. For metal/aluminum doors, route cables inside door.

#### Wood Door Shown

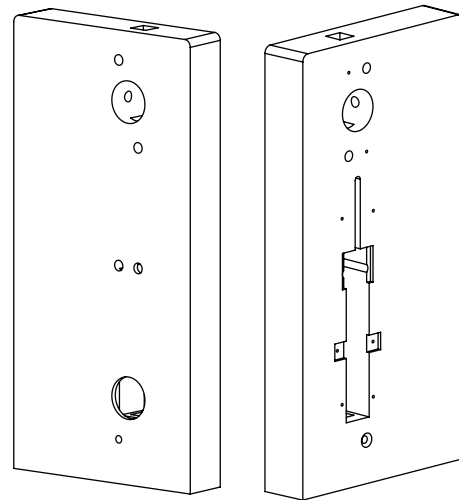

Fig. 1B

### Step #2 - Inner Case Assembly Installation

#### A. Wood Door (WD)

Install the inner case assembly with (2) #12 x 1" Phillips flathead screw (Fig. 2A).

#### B. Metal Door (MD/AD)

1. Assemble rods to inner case.
2. Slide rod assembly into door and secure with #10-24 x 3/8" screw for top inner case assembly and #10-24 x 1/2" screw for bottom inner case assembly (Fig. 2B).

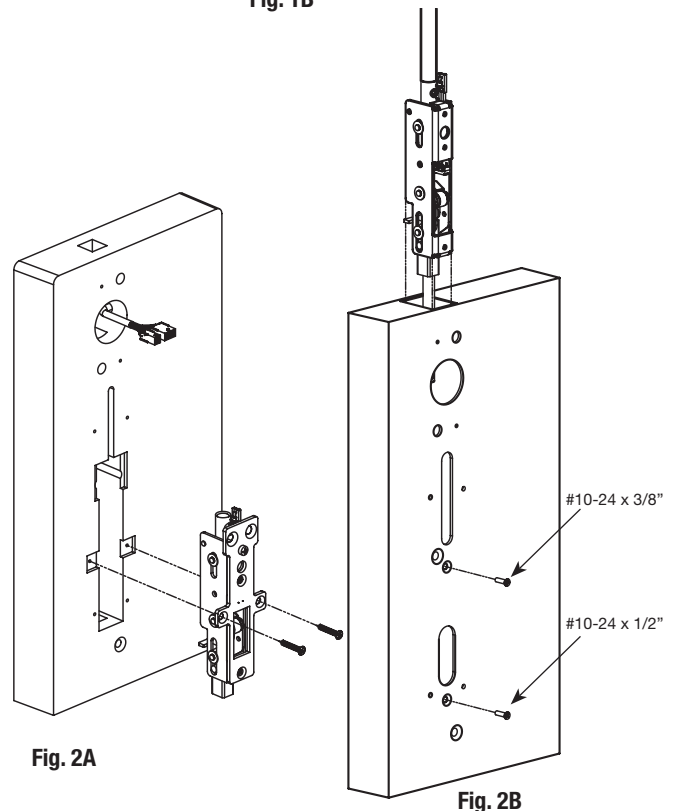

Fig. 2A

Fig. 2B

## 8600 Installation Instructions (Continued)

### Step #3 – Install Outside Exit Trim (ET) and Chassis

#### A. Outside Trim

1. For exterior applications, use ET gasket (52-0263) to seal ET escutcheon and outside door surface (Fig. 3A).
2. Route ET wire harness through inner chassis assembly:
  - For wood doors: Route wire harness in cutout.
  - For metal doors: Route wire harness through access hole.
3. Mount ET trim to inner chassis assembly using (2) # 1/2 -20 x 2-3/8" flat head machine screws. ET spindle engages inside the inner chassis assembly (Fig. 3B).

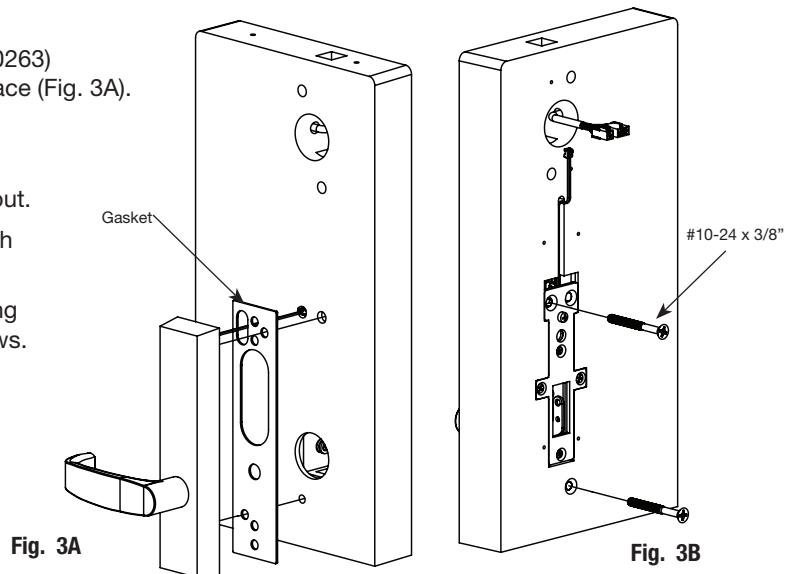

#### B. Chassis

1. Position chassis carefully onto the inner chassis assembly from the inside of the door. Be careful not to pinch wire harness.
2. Fasten the chassis to door using (4) #12 x 1" Phillips flathead screws (Fig. 3C).

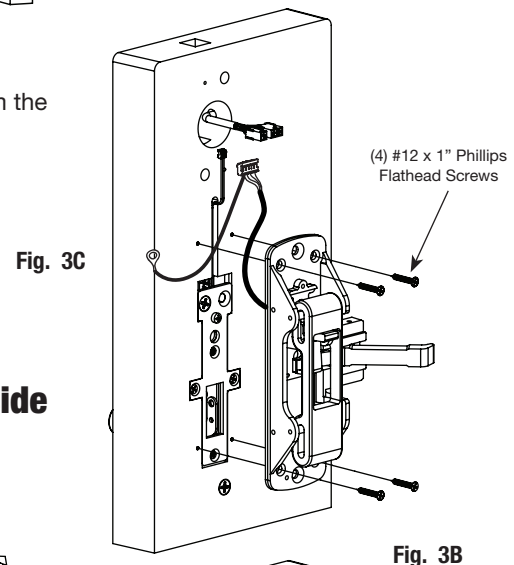

### Step #4 – Attach Ground Wire and Install Outside Escutcheon and Inside Mounting Plate

1. Connect pin 5 green/yellow ground wire ring terminal to top right screw (Fig. 4A and 4B).
2. Secure the mounting plate with (2) #8 x 1/2" self-tapping screws (Fig. 4A).
3. Feed the reader cable connector located on the back of the outside escutcheon from the outside of door through door.
4. Securely tighten the outside escutcheon with through-bolts using (2) #8-32 x 2" Phillips flat head screws through the mounting plate.

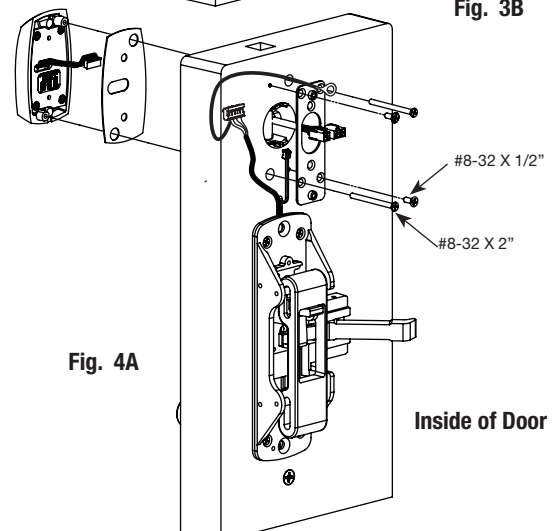
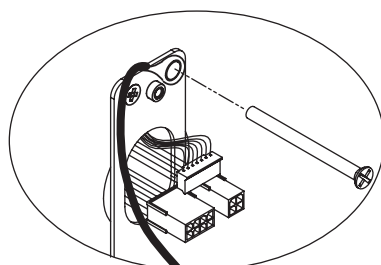



### Step #5 – Install Gasket

Add Gasket (if necessary):

Remember the inside gasket must be used when installing in an outdoor application.

Remove backing and place gasket on door (Fig. 5A).

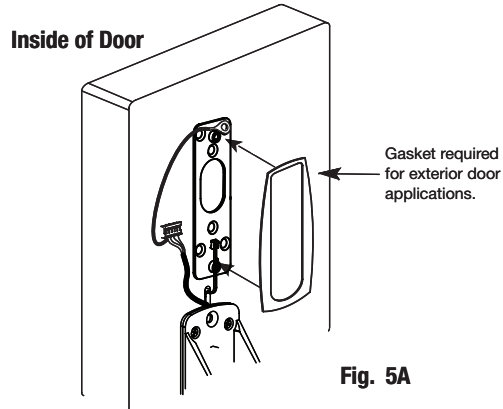

### Step #6 – Connect ElectroLynx

1. Connect P5 (7 Pin Connector) from reader board to J5 on interior escutcheon PCB assembly (Fig. 6A).
2. Connect ElectroLynx harness (4 and 8-pin) from door harness to ElectroLynx harness on interior PCB assembly (Fig. 6A).

**NOTES:**

Neatly fold the wires onto themselves and into the remaining space to prevent pinching wires when mounting escutcheon.

Do not tuck extra mortise lock body wires back inside the lock body cylinder hole.

Connectors go on only one way.

Do not offset connector and be sure they are completely seated.

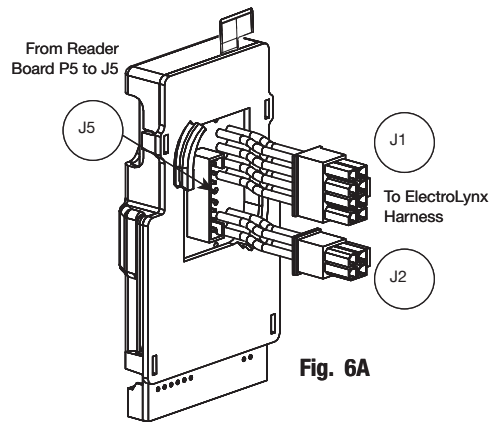

PCB Layout - Wire Assignments - ElectroLynx Assembly (Molex)					
J2		J1			
1-Violet Lock DC Neg (Solenoid, neg)	3 - Pink NOT USED	1- Black PWR NEG	3-White Wiegand DATA 1	5-Orange RX (N/O)	7-Brown EGND
2-Gray, Lock DC Pos (Solenoid, pos)	4-Tan NOT USED	2-Red PWR POS	4-Green Wiegand DATA 0	6-Blue RX (COM)	8-Yellow LED

Copyright © 2009 Sargent Manufacturing Company, an ASSA ABLOY Group company. All rights reserved. Reproductions in whole or in part without express written permission of Sargent Manufacturing Company is prohibited.

## Step #7 – Position Outside Wires

Please follow these steps prior to installing inside escutcheon to prevent any damage caused by pinching wires:

1. Once wires are arranged, position piece at a rotated angle against the door, under earth ground wire.
2. Press piece against door unwhile turning clockwise (Fig. 7A).
3. Twist into place, perpendicular with door (Fig. 7B).

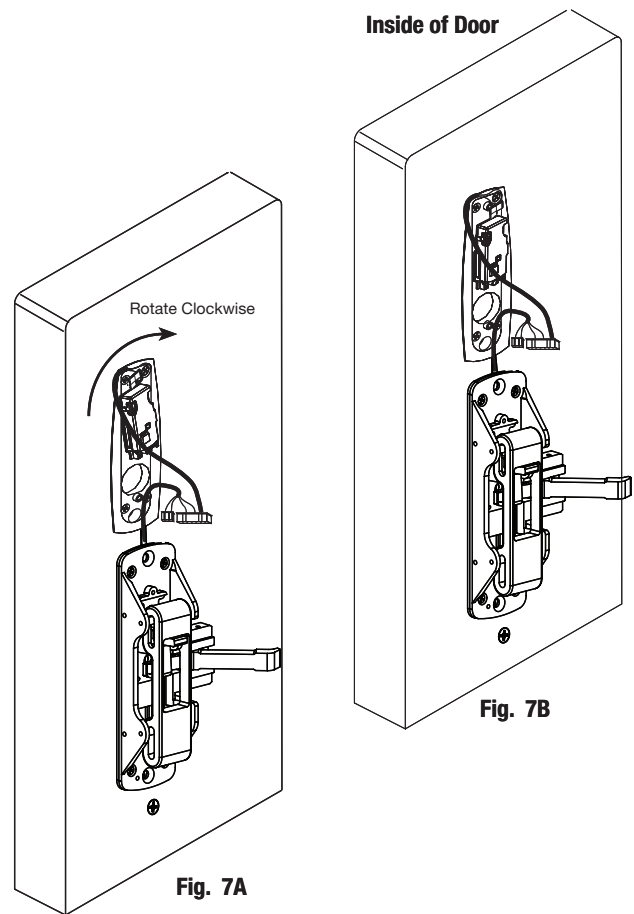

## Step #8 – Attach Connectors (Exterior PCB Assembly)

1. Connect P3 (2-pin connector) from lock body to J3 on module (Fig. 8A).
2. Connect P4 (6-pin connector) from lock body to J4 on module (Fig. 8A).

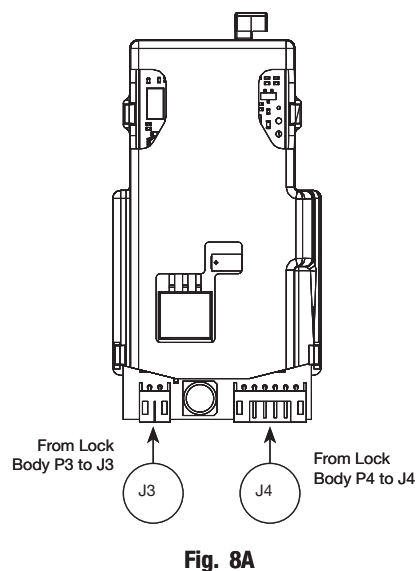

### Step #9 – Install Inside Escutcheon

1. Position inside gasket and escutcheon against door. Verify that no wires are being pinched.
2. Mount inside escutcheon assembly to plate using (2) #8-32 x 5/8" Phillips flat head undercut machine screws.

Inside of Door

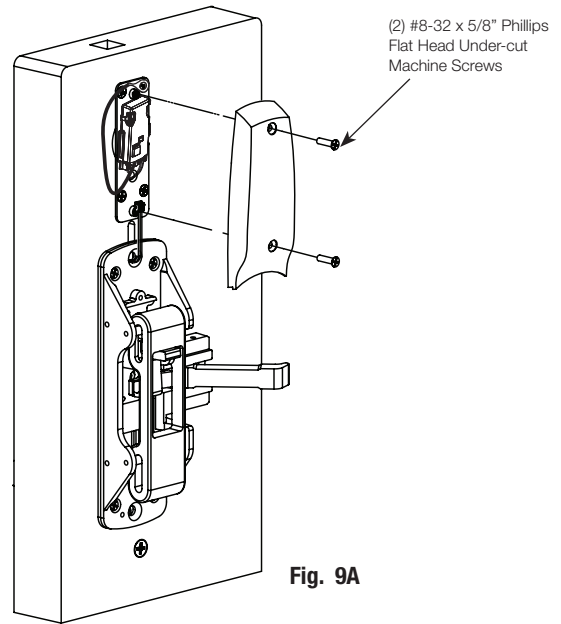

Fig. 9A

### Step #10 – Install Rail Assembly

1. Retrieve harness from end of rail. Harness has limited travel and can be damaged.
2. Attach harness to female connector on chassis.
3. Install rail and screws per exit device instructions.

Note: This view shows rim exit device version.

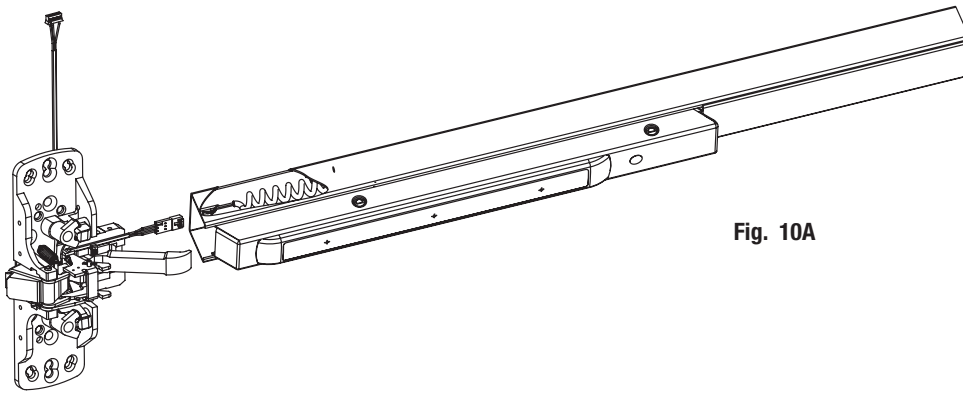
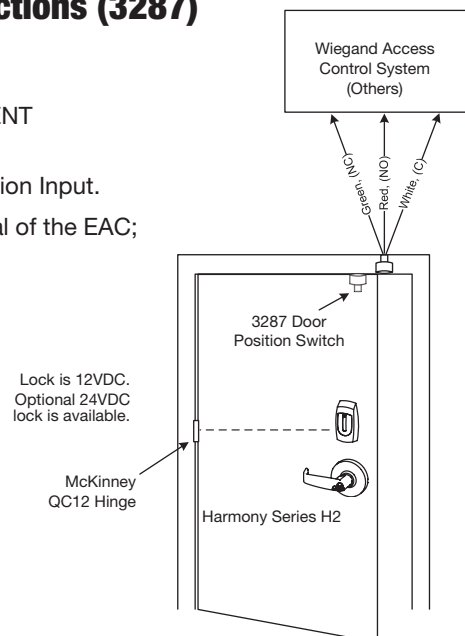

Fig. 10A

### Step #11 - Concealed Door Position Switch Instructions (3287)

Use SARGENT 3287 Concealed Door Position Switch with this Harmony H2 series product:

1. Install the 3287 Concealed Door Position Switch described in SARGENT document A7448B.
2. Wire the 3287 Concealed Door Position Switch to the EAC door position Input.
3. Connect the common wire of the switch to the common input terminal of the EAC; and the normally open wire of the switch to the normally open input terminal of the EAC.



Lock is 12VDC.  
Optional 24VDC  
lock is available.

McKinney  
QC12 Hinge

Harmony Series H2

Wiegand Access  
Control System  
(Others)

Common  
Red (NO)  
White (C)

3287 Door  
Position Switch

>> Continue to Section 9 for Wiring Diagrams to wire Device to EAC Panel. <<

Fig. 11A

## 7 Installation Instructions For Harmony Series H2 8800 Rim Exit Device

### Parts Breakdown

Left Hand Reverse Door Shown

#### Tools Required

- Phillips screw driver (standard size)
- Flat blade screw driver (standard)

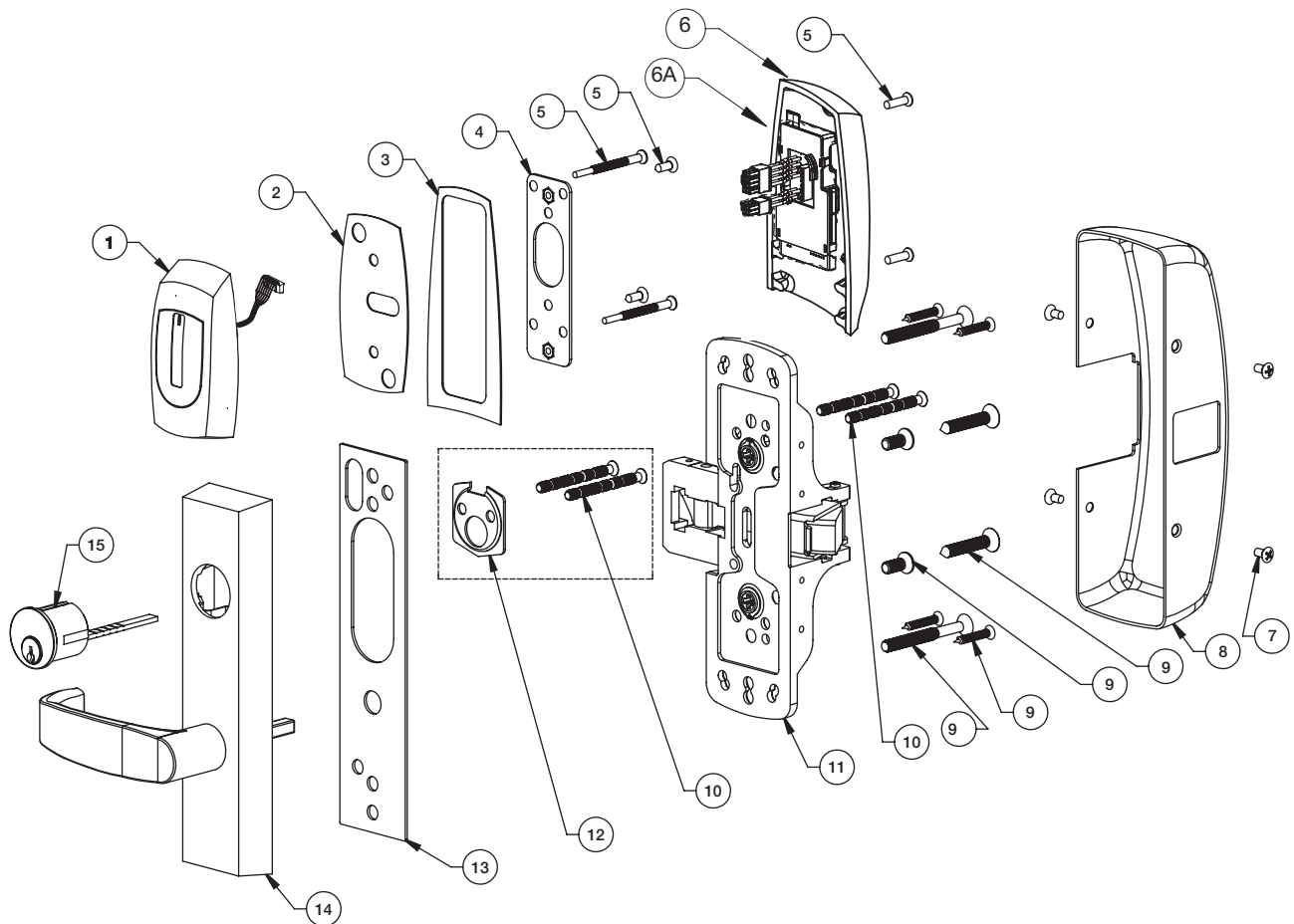

## Parts Breakdown For Harmony Series H2 8800 (Continued)

### Shipment Contents

ITEM	PART #	Description	Req.
1	52-4038	Outside Harmony Escutcheon Assembly	1
2	52-0792	Outside Weather Gasket	1
3	52-0793	Inside Weather Gasket	1
4	52-5219	Harmony Inside Escutcheon Mounting Plate	1
5	52-5236	Screw Pack (Escutcheon)	1
6	68-1581	Inside Escutcheon Assembly	1
6A	52-4036	H2 Controller Assembly	1
7	68-3905	Screw Pack (Rail and Chassis Cover)	1
8	68-0406	Chassis Cover	1
9	68-3922	Screw Pack (Chassis)	1
10	13-0074	Cylinder Connecting Screws	2
11	68-7255	8800 Chassis Assembly (Standard)	1
	68-7256	8800 Chassis Assembly (12-)	
	68-5836	8800 Chassis Assembly (GL)	
	68-5837	8800 Chassis Assembly (12-, GL)	
12	13-0086	Cylinder back Plate Used with non-Sargent Cylinders)	1
13	52-0263	ET Trim Gasket	1
14	*Harmony Trim is Ordered as "N1"		1
		N1-773-ET 12V Fail Safe Without Cylinder	
		N1-773-ET 24V Fail Safe Without Cylinder	
		N1-774-ET 12V Fail Secure Without Cylinder	
		N1-774-ET 24V Fail Secure Without Cylinder	
		N1-775-ET 12V Fail Safe Without Cylinder	
		N1-775-ET 24V Fail Safe Without Cylinder	
		N1-776-ET 12V Fail Secure Without Cylinder	
	N1-776-ET 24V Fail Secure Without Cylinder		
15	--	Reference Harmony Series Catalog for Available Cylinders	1
16	3287	DPS Door Position Switch (not shown)	1
17	A8029	Installation Instructions (not shown)	1
18	A7883	Field Template (not shown)	1
19	4615	Manufacturer Template (not shown)	1

### How to Specify ET Trim

How to order without an exit device.

Specify: 7 for 700 Series ET, Function, Suffix, Lever, Finish and handing (e.g., 775-8 ETL x 26D x RHRB).

Note: Suffix requirements are based on type of device to be used:

- -8 suffix is required for 8800, 8500, NB8700, PP, PR and SP8700 devices, except with these functions: 04, 10, 16, 40 and 44.
- -6 suffix is required for all PP, PR, SP, LP, LR and LS devices.
- -4 suffix is required for all 8400, WD, MD and AD 8600 devices.
- No suffix is necessary for all 8900, 8300, 8700 with bottom rod and 8800, 8500, NB8700, PP, PR & SP8700 devices with these functions: 04, 10, 16, 40 and 44.

## Step #1 – Door Preparation

### A. Verify Hand and Bevel of Door

- Check hand of door. Exit Device may be handed.
- Door should be fitted and hung.
- Verify box label for size of exit device, function and hand.

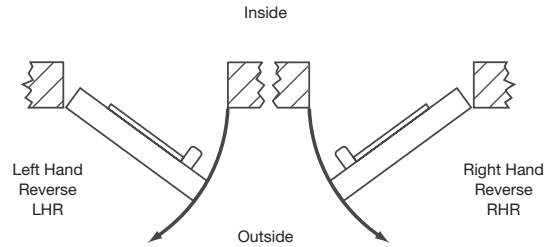

Fig. 1A

### B. Door Preparation

Prepare door according to appropriate template. If necessary, refer to website, [www.intelligentopenings.com](http://www.intelligentopenings.com):

- Field prep template: A7883
- Manufacturer template: 4615
- Reference exit device templates: 4415, and 4530

Note: Instruction examples show wood door installation. For metal doors, route cables inside door.

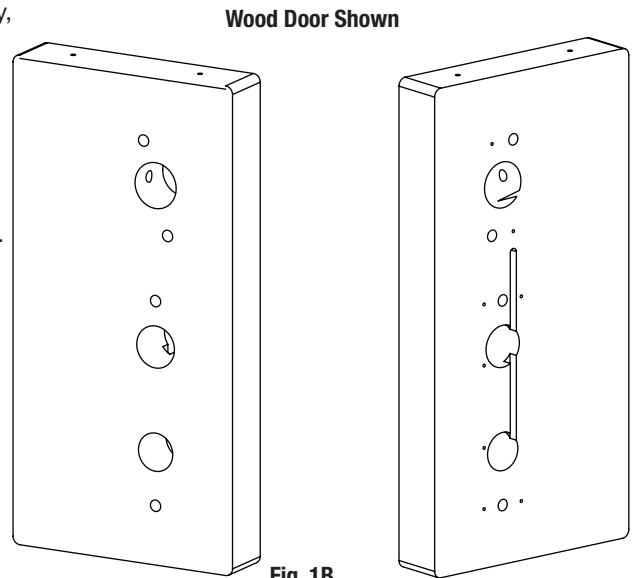

Fig. 1B

## Step #2 – Outside Trim (Exit Trim, ET) Installation

1. For exterior applications, use ET gasket (52-0263) to seal between ET escutcheon and outside door surface (Fig. 2B).
2. Route ET wire harness in cutout for wood doors and through access hole for metal doors (Fig. 2A).
3. Hold ET control onto door.

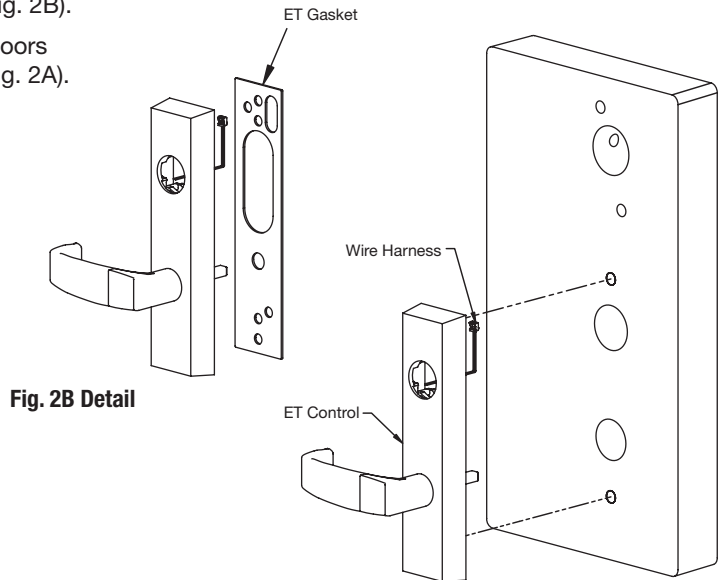

Fig. 2A

Copyright © 2009 Sargent Manufacturing Company, an ASSA ABLOY Group company. All rights reserved. Reproductions in whole or in part without express written permission of Sargent Manufacturing Company is prohibited.

06/30/09

## 8800 Installation Instructions (Continued)

### Step #3 – Mounting Chassis

1. Position chassis carefully, not to pinch wire harness.
2. ET spindle will engage the lower hub of chassis.
3. Cylinder tailpiece should engage upper hub of the chassis.
4. Though bolt chassis to ET with (2) 1/4 -20 x 2-3/8" flat head machine screws.
5. Using (4) #10 wood screws or #10-24 machine screws fasten chassis to door.

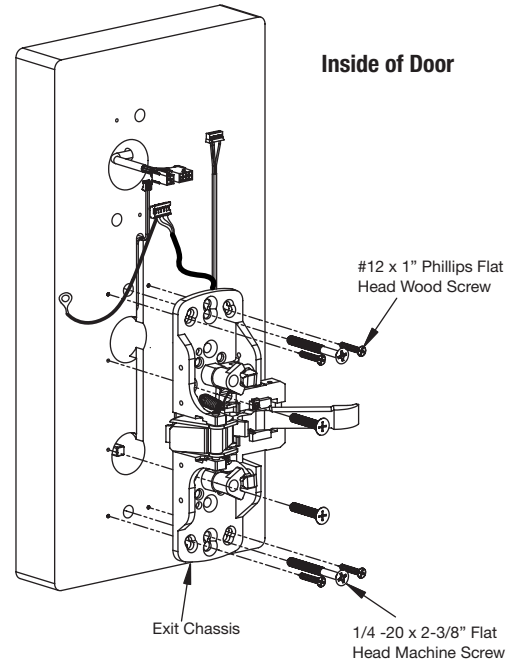

Fig. 3A

### Step #4 – Cylinder Installation

1. Position cylinder in ET control.
2. For non-Sargent cylinder ONLY:  
Secure cylinder with cylinder backplate using (2) #12-24 x 1-7/8" screws.
3. Make sure ET harness is clear of cylinder and cylinder tailpiece.

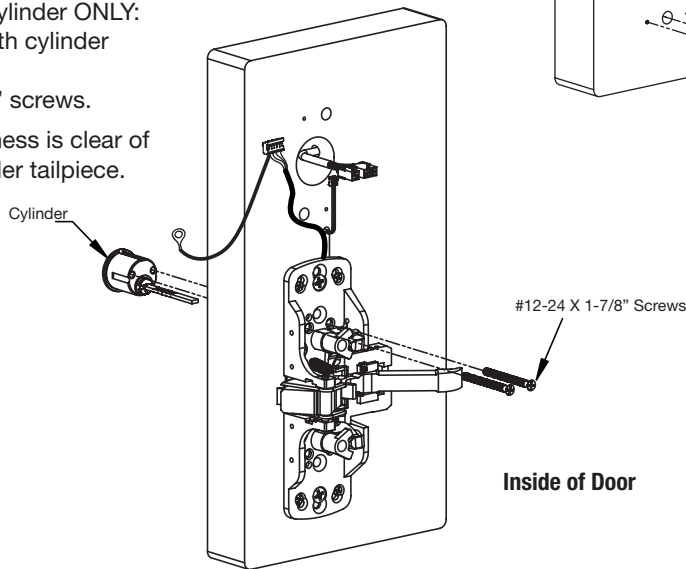

Fig. 4A

### Step #5 – Outside Escutcheon and Inside Mounting Plate and Ground Wire Installation

1. Connect pin 5 green/yellow ground wire ring terminal to top right screw (Fig. 5A and 5B).
1. Secure the mounting plate with (2) self-tapping screws (#8 x 1/2").
2. Feed the reader cable connector located on the back of the outside escutcheon from the outside of door through door.
3. Securely tighten the outside escutcheon with (2) through-bolts (#8-32 x 2") Phillips flat head screws through the mounting plate.

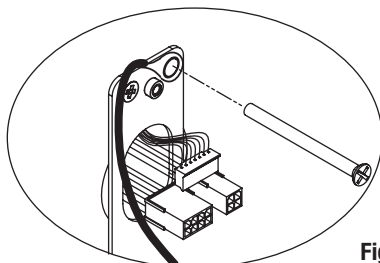

Fig. 5B

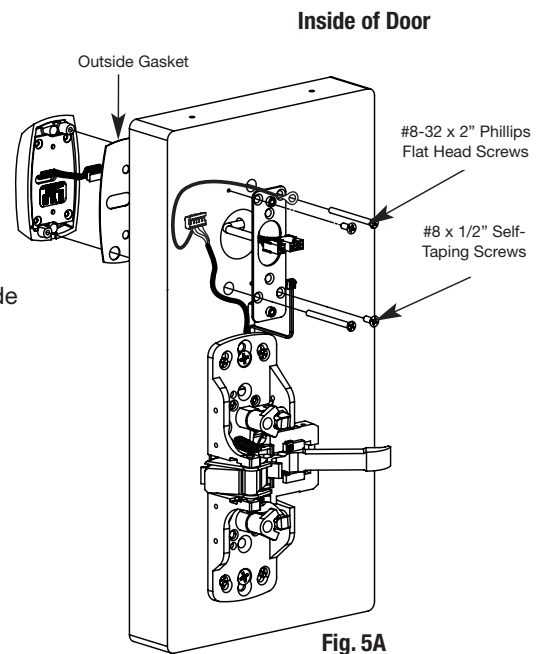

Fig. 5A

## Step #6 – Install Gasket

Add Gasket (if necessary):

Remember the inside gasket must be used when installing in an outdoor application.

Remove backing and place gasket on door (Fig. 6A).

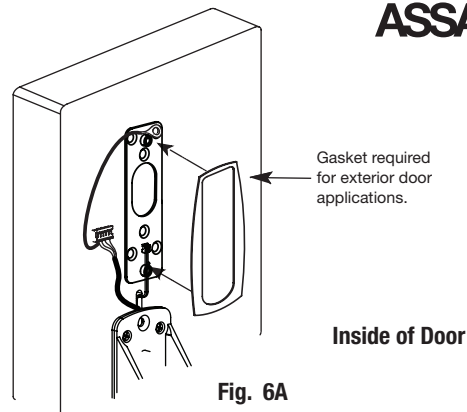

Fig. 6A

## Step #7 – Connect ElectroLynx

1. Connect P5 (7 Pin Connector) from reader board to J5 on interior escutcheon PCB assembly (Fig. 7A).
2. Connect ElectroLynx harness (4 and 8-pin) from door harness to ElectroLynx harness on interior PCB assembly (Fig. 7A).

NOTES:

Neatly fold the wires onto themselves and into the remaining space to prevent pinching wires when mounting escutcheon.

Do not tuck extra mortise lock body wires back inside the lock body cylinder hole.

Connectors go on only one way.

Do not offset connector and be sure they are completely seated.

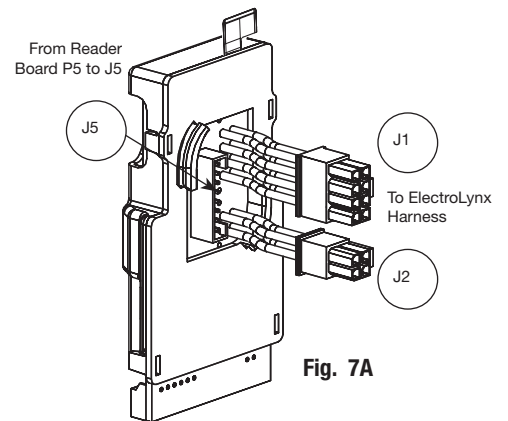

Fig. 7A

### PCB Layout - Wire Assignments - ElectroLynx Assembly (Molex)

J2		J1			
1-Violet Lock DC Neg (Solenoid, neg)	3 - Pink NOT USED	1- Black PWR NEG	3-White Wiegand DATA 1	5-Orange RX (N/O)	7-Brown EGND
2-Gray, Lock DC Pos (Solenoid, pos)	4-Tan NOT USED	2-Red PWR POS	4-Green Wiegand DATA 0	6-Blue RX (COM)	8-Yellow LED

## Step #8 – Outside Escutcheon and Wire Positioning

Please follow these steps prior to installing inside escutcheon assembly to prevent any damage caused by pinching wires:

1. Align the ElectroLynx® connectors (8 and 4-pin) to one side of the wire guide inside of the door prep. The reader connections and excess wire are arranged on the other.
2. Connect the ElectroLynx® connectors (8 and 4-pin) and establish their position inside of the door prep on the proper side of the wire guide (Fig. 8A).
3. Neatly route the remaining wires onto themselves and into the remaining space to prevent pinching wires when mounting the escutcheon (Fig. 8B).

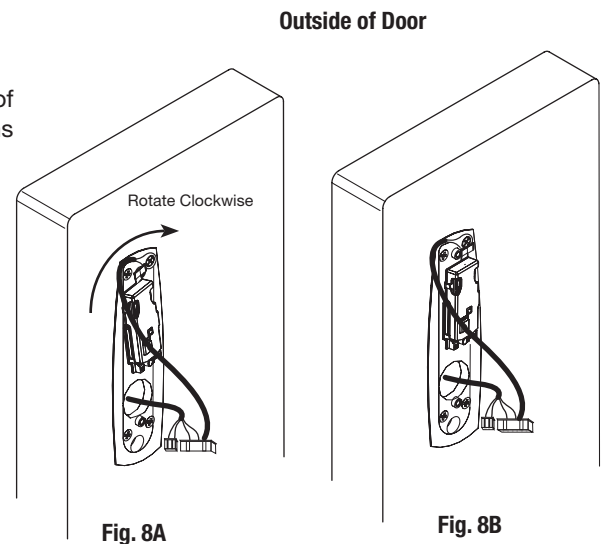

Fig. 8A

Fig. 8B



### Step #9 – Connector Attachment (Exterior PCB Assembly)

1. Connect P3 (2-pin connector) from lock body to J3 on module (Fig. 9A).
2. Connect P4 (6-pin connector) from lock body to J4 on module (Fig. 9A).

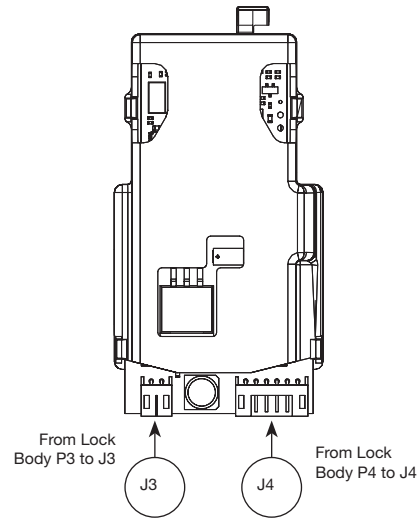

Fig. 9A

### Step #10 – Installation of Inside Escutcheon

1. Position inside gasket and escutcheon against door. Verify that no wires are being pinched.
2. Mount inside escutcheon assembly to plate using (2) #8-32 x 5/8" Phillips flat head undercut machine screws.

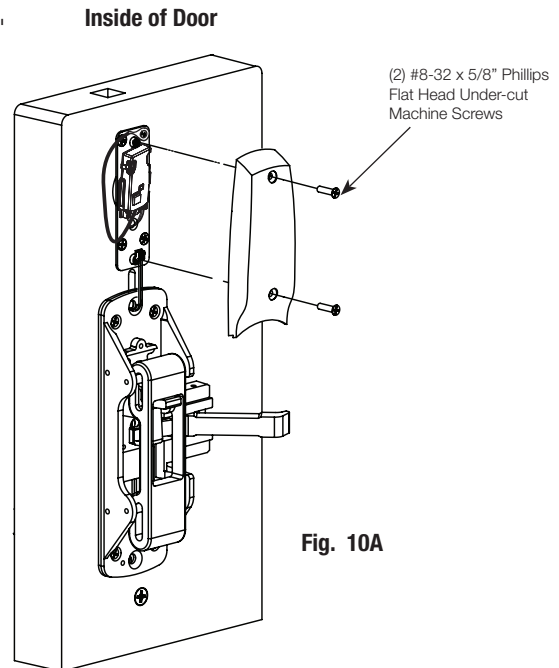

Fig. 10A

## Step #11 – Installation of Rail Assembly

1. Retrieve harness from end of rail. Harness has limited travel and can be damaged.
2. Attach harness to female connector on chassis.
3. Install rail and screws per exit device instructions.

Note: This view shows rim exit device version

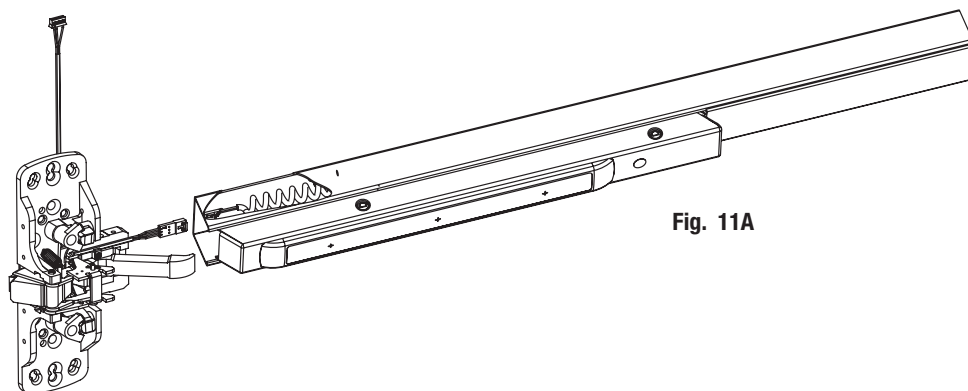

Fig. 11A

## Step #12 - Concealed Door Position Switch (3287) Instructions

Use SARGENT 3287 Concealed Door Position Switch with this Harmony H2 series product:

1. Install the 3287 Concealed Door Position Switch described in SARGENT document A7448B.
2. Wire the 3287 Concealed Door Position Switch to the EAC door position Input.
3. Connect the common wire of the switch to the common input terminal of the EAC; and the normally open wire of the switch to the normally open input terminal of the EAC.

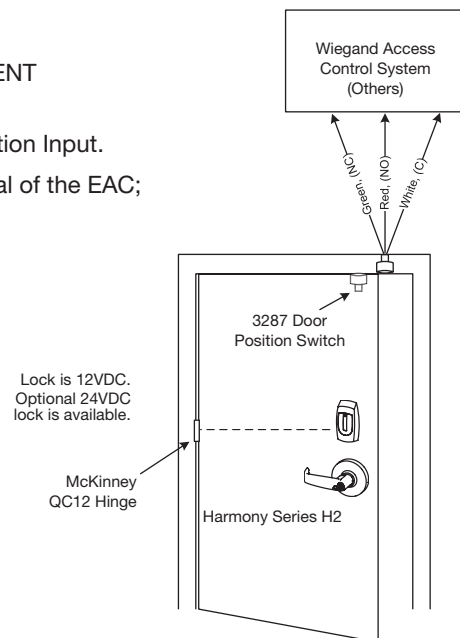

Fig. 12A

>> Continue to Section 9 for Wiring Diagrams to wire Device to EAC Panel. <<

## 8 Installation Instructions For Harmony Series H2 8900 Mortise Exit Device

### Parts Breakdown

Left Hand Reverse Door Shown

#### Tools Required

- Phillips screw driver (standard size)
- Flat blade screw driver (standard)

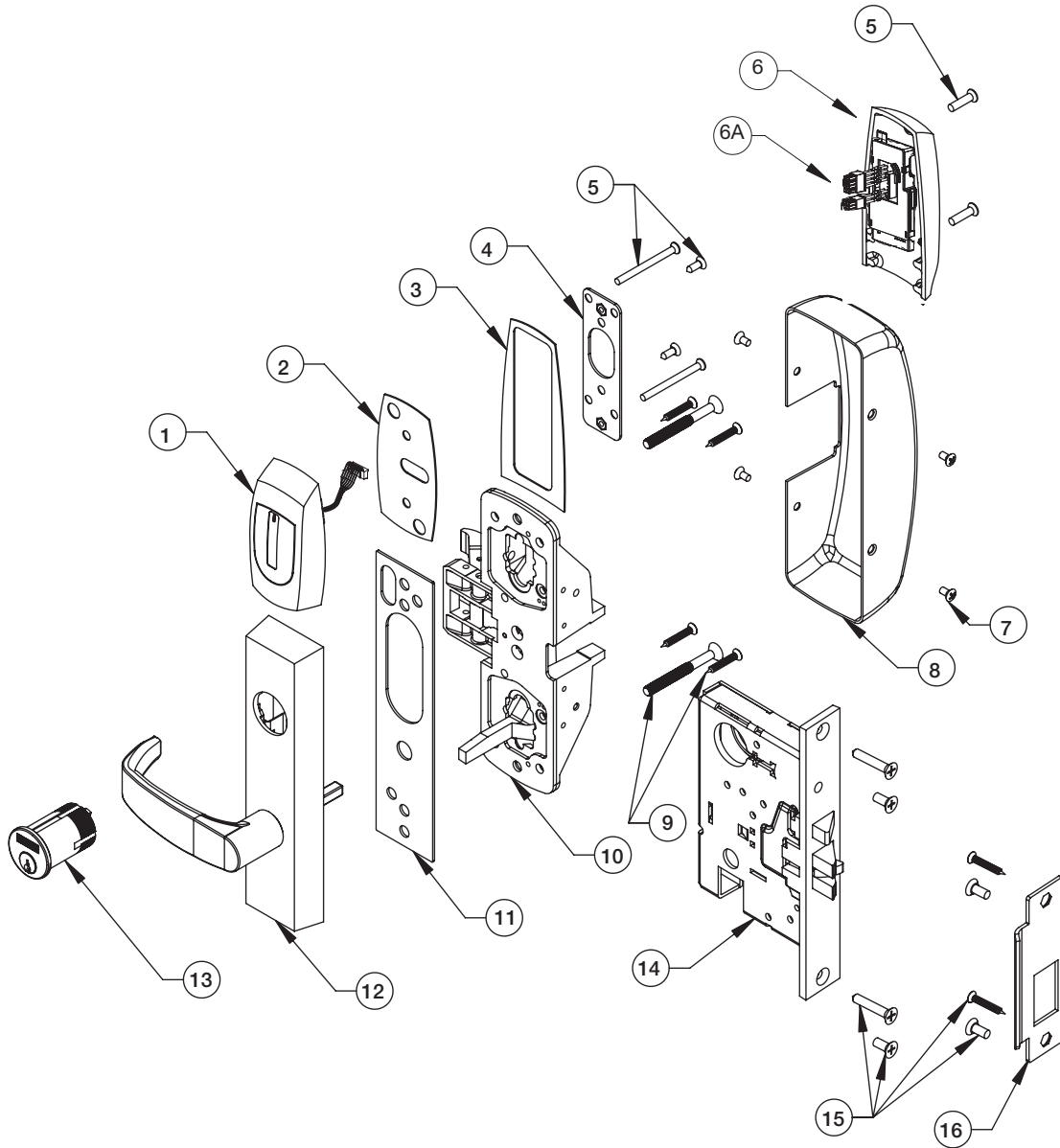

## Parts Breakdown For Harmony Series H2 8900 (Continued) Shipment Contents

ITEM	PART #	Description	Req.
1	52-4038	Outside Harmony Escutcheon Assembly	1
2	52-0792	Outside Harmony Gasket	1
3	52-0793	Inside Harmony Gasket	1
4	52-5219	Harmony Inside Escutcheon Mounting Plate	1
5	52-5236	Screw Pack (Escutcheon)	1
6	68-1581	Inside Harmony Escutcheon Assembly	1
6A	52-4036	H2 Controller Assembly	1
7	68-3905	Screw Pack (Rail and Chassis Cover)	1
8	68-0407	Chassis Cover	1
9	68-3922	Screw Pack (Chassis)	1
10	68-7253	8900 Chassis Assembly LHRB	1
	68-5754	8900 Chassis Assembly RHRB	1
11	52-0263	ET Trim Gasket	1
12	*Harmony Trim is Ordered as "N1"		
		N1-773-ET 12V Fail Safe Without Cylinder	1
		N1-773-ET 24V Fail Safe Without Cylinder	
		N1-774-ET 12V Fail Secure Without Cylinder	
		N1-774-ET 24V Fail Secure Without Cylinder	
		N1-773-ET 12V Fail Safe With Cylinder	
		N1-773-ET 24V Fail Safe With Cylinder	
		N1-774-ET 12V Fail Secure With Cylinder	
	N1-774-ET 24V Fail Secure With Cylinder		
13	--	Reference Harmony Series Catalog for Available Cylinders	1
14	915	8900 Lock Body Assembly LHRB	1
	915	8900 Lock Body Assembly RHRB	
15	99-2628	Screw Pack (Mortise Lock)	1
16	99-0131TAB	Strike Pack (Specify Bevel and Lip Length)	1
17	A8029	Instruction Sheet (not shown)	1
18	A7948	Field Prep Template (not shown)	1
19	4613	Manufacturer Template (not shown)	1

### How to Specify ET Trim

How to order without an exit device.

Specify: 7 for 700 Series ET, Function, Suffix, Lever, Finish and handing (e.g., 775-8 ETL x 26D x RHRB).

Note: Suffix requirements are based on type of device to be used:

- -8 suffix is required for 8800, 8500, NB8700, PP, PR and SP8700 devices, except with these functions: 04, 10, 16, 40 and 44.
- -6 suffix is required for all PP, PR, SP, LP, LR and LS devices.
- -4 suffix is required for all 8400, WD, MD and AD 8600 devices.
- No suffix is necessary for all 8900, 8300, 8700 with bottom rod and 8800, 8500, NB8700, PP, PR & SP8700 devices with these functions: 04, 10, 16, 40 and 44.

## Step #1 – Door Preparation

### A. Verify Hand and Bevel of Door

- Check hand of door. Exit Device may be handed.
- Door should be fitted and hung.
- Verify box label for size of exit device, function and hand.

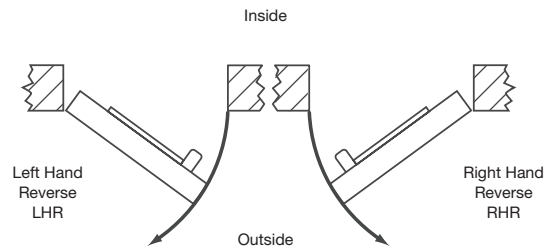

Fig. 1A

### B. Door Preparation

Prepare door according to appropriate template. If necessary, refer to website, [www.intelligentopenings.com](http://www.intelligentopenings.com):

- Field prep template: A7948 (ships with product)
- Door manufacturer templates: 4613, 4290, and 4314.

Note: Instruction examples show wood door installation. For metal doors, route cables inside door.

Wood Door Shown

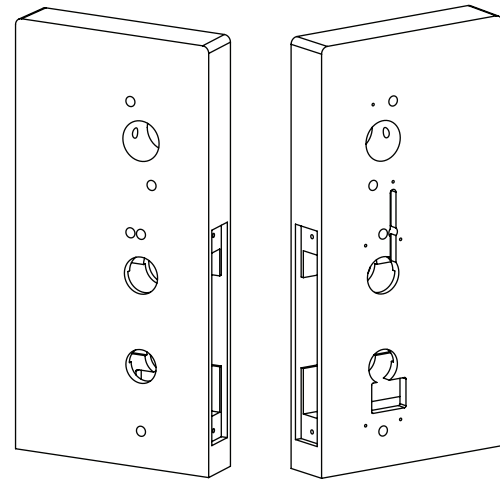

Fig. 1B

## Step #2 – Mortise Lock and Outside Exit Trim (ET) Installation

1. Slide mortise lock into pocket and securely fasten with (2) flat head screws (Fig. 2A).
2. Route “ET” harness through wire cutout on inside of door.
3. For exterior applications, use gasket (52-0263) to seal between ET escutcheon and outside door surface (Fig. 2B Detail).
4. Place ET control on door with spindle engaging the mortise lock.

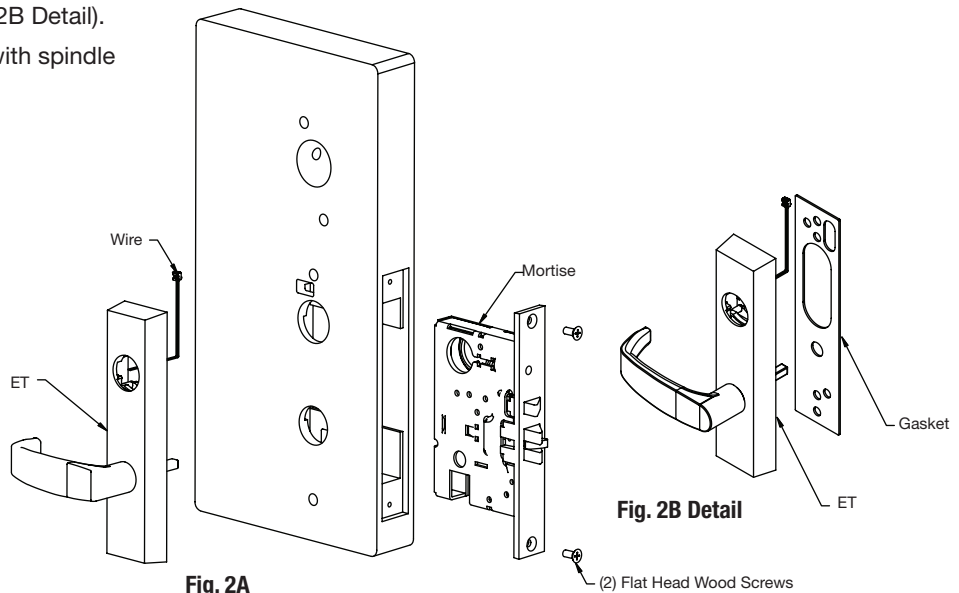

Fig. 2A

Fig. 2B Detail

(2) Flat Head Wood Screws

## 8900 Installation Instructions (Continued)

### Step #3 – Cylinder Installation

For devices without cylinders, skip this section.

1. Back cylinder set screw out slightly (Fig. 3A).
2. Insert cylinder through “ET” control and thread into mortise lock until cylinder is flush with “ET”.

Keyway must be vertical and SARGENT

Position Sargent Logo at top of cylinder (Fig. 3B).

3. Tighten cylinder set screw.

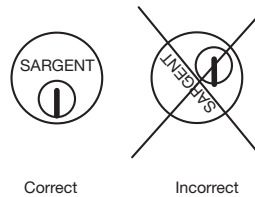

Fig. 3B Detail

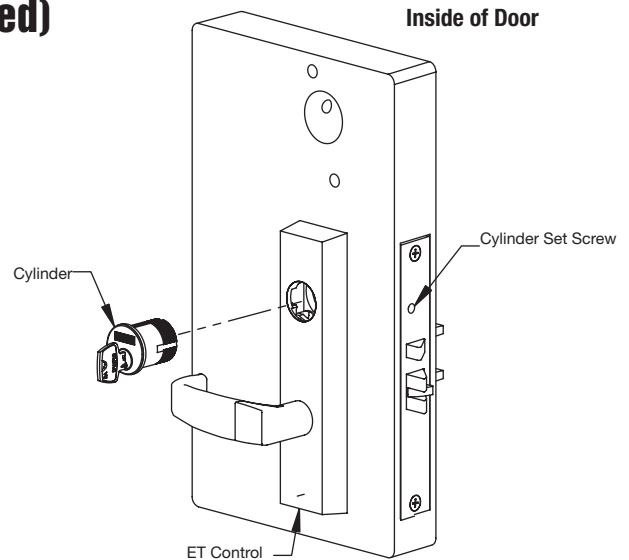

Fig. 3A

### Step #4 – Chassis to Door Installation

1. Route ET wire harness along track cutout for wood doors and access hole for metal doors (Fig. 4A).
  2. Temporarily attach chassis to rail, then lock push rail down using hex or cylinder key or by holding push rail in the depressed position on 8900 exit device (Fig. 4B).
  3. Position chassis and rail on door so that lever arm is under rear section of mortise lock lever then lift up until latch bolt is completely retracted. With chassis in this position and rail horizontal, mark location of chassis mounting holes (Fig. 4C). Drill holes for screws.
  4. Release push rail and disassemble chassis from rail. Mount chassis on door.
- Do not pinch harness wires.
5. Fasten exit chassis to door using (4) #10 wood screws or #10-24 x 3/4" machine screws.
  6. Using (2) 1/4-20 x 2-3/8" flat head screws, attach “ET” to chassis.

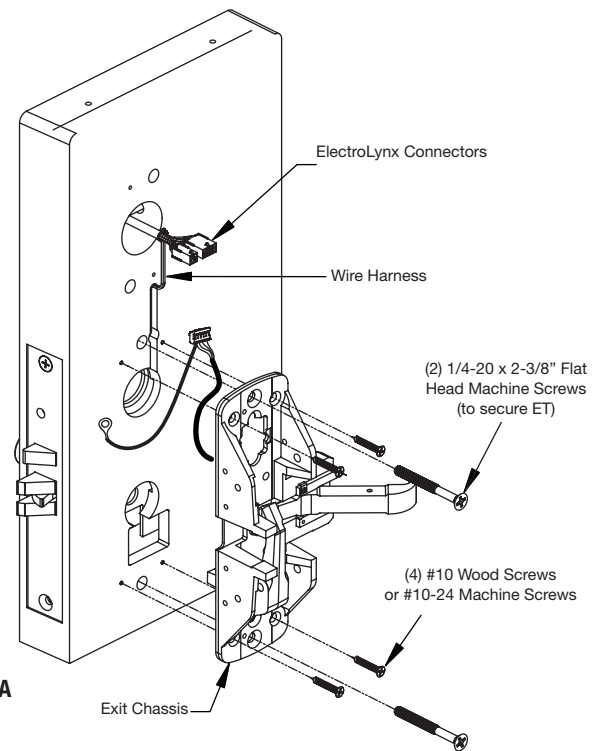

Fig. 4A

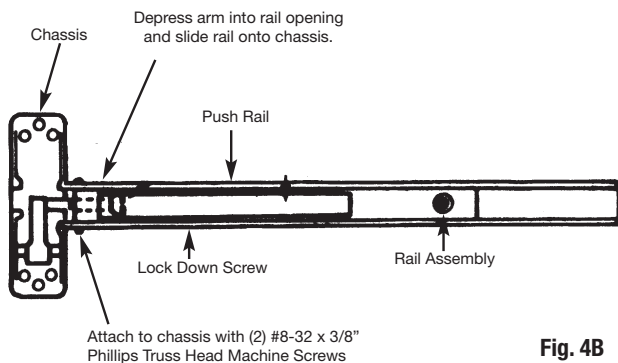

Fig. 4B

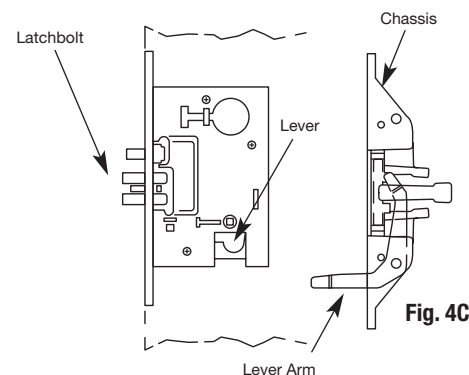

Fig. 4C

### Step #5 – Outside Escutcheon and Inside Mounting Plate and Ground Wire Installation

1. Connect pin 5 green/yellow ground wire ring terminal to top right screw (Fig. 5A and 5B).
1. Secure the mounting plate with (2) self-tapping screws (#8 x 1/2”).
2. Feed the reader cable connector located on the back of the outside escutcheon from the outside of door through door.
3. Securely tighten the outside escutcheon with (2) through-bolts (#8-32 x 2”) Phillips flat head screws through the mounting plate.

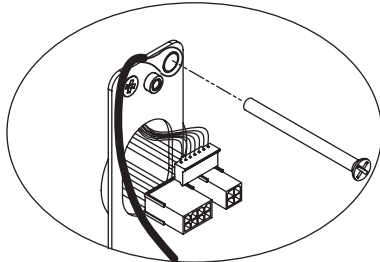

Fig. 5B

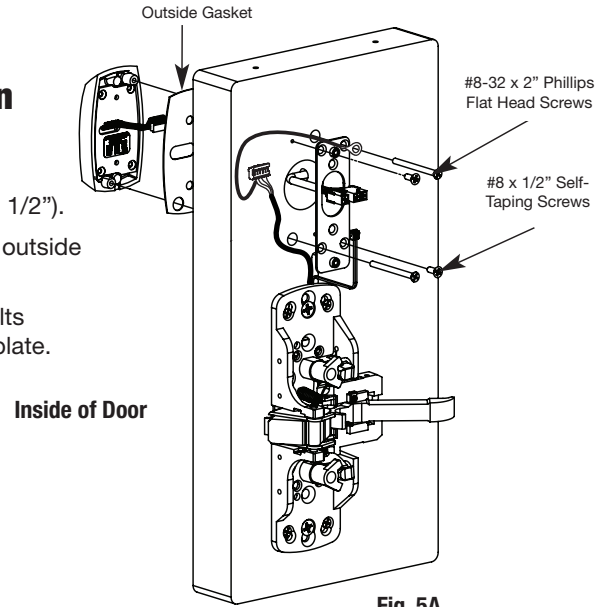

Fig. 5A

### Step #6 – Install Gasket

Add Gasket (if necessary):

Remember the inside gasket must be used when installing in an outdoor application.

Remove backing and place gasket on door (Fig. 6A).

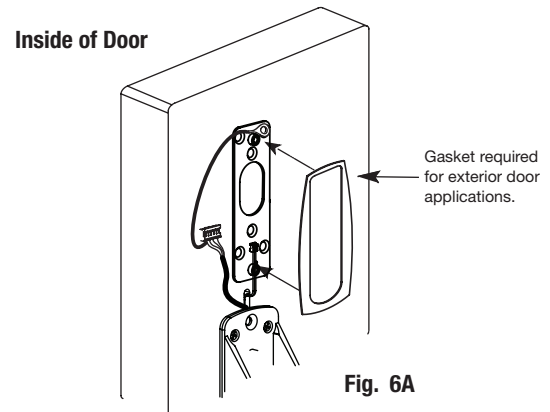

Fig. 6A

### Step #7 – Connect ElectroLynx

1. Connect P5 (7 Pin Connector) from reader board to J5 on interior escutcheon PCB assembly (Fig. 7A).
2. Connect ElectroLynx harness (4 and 8-pin) from door harness to ElectroLynx harness on interior PCB assembly (Fig. 7A).

#### NOTES:

Neatly fold the wires onto themselves and into the remaining space to prevent pinching wires when mounting escutcheon.

Do not tuck extra mortise lock body wires back inside the lock body cylinder hole.

Connectors go on only one way.

Do not offset connector and be sure they are completely seated.

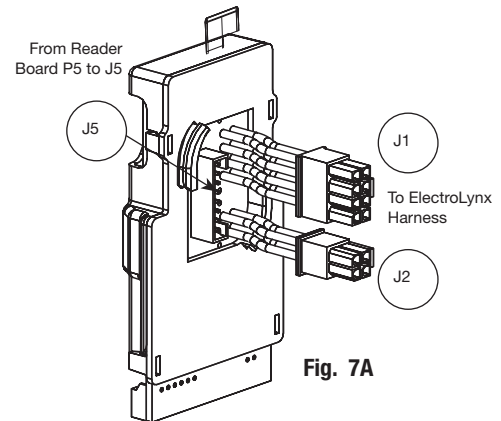

Fig. 7A

PCB Layout - Wire Assignments - ElectroLynx Assembly (Molex)					
J2		J1			
1-Violet Lock DC Neg (Solenoid, neg)	3 - Pink NOT USED	1- Black PWR GND	3-White Wiegand DATA 1	5-Orange RX (I/O)	7-Brown EGND
2-Gray, Lock DC Pos (Solenoid, pos)	4-Tan NOT USED	2-Red PWR POS	4-Green Wiegand DATA 0	6-Blue RX (COM)	8-Yellow LED

## Step #8 – Outside Escutcheon and Wire Positioning

Please follow these steps prior to installing inside escutcheon assembly to prevent any damage caused by pinching wires:

1. Align the ElectroLynx® connectors (8 and 4-pin) to one side of the wire guide inside of the door prep. The reader connections and excess wire are arranged on the other.
2. Connect the ElectroLynx® connectors (8 and 4-pin) and establish their position inside of the door prep on the proper side of the wire guide (Fig. 8A).
3. Neatly route the remaining wires onto themselves and into the remaining space to prevent pinching wires when mounting the escutcheon (Fig.8B).

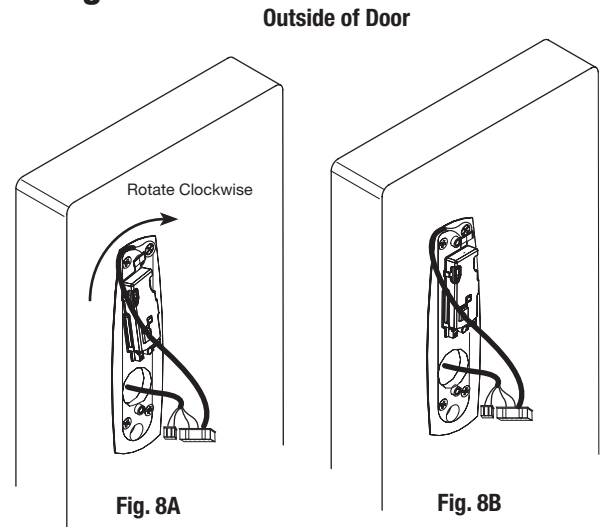

## Step #9 – Connector Attachment (Exterior PCB Assembly)

1. Connect P3 (2-pin connector) from lock body to J3 on module (Fig. 9A).
2. Connect P4 (6-pin connector) from lock body to J4 on module (Fig. 9A).

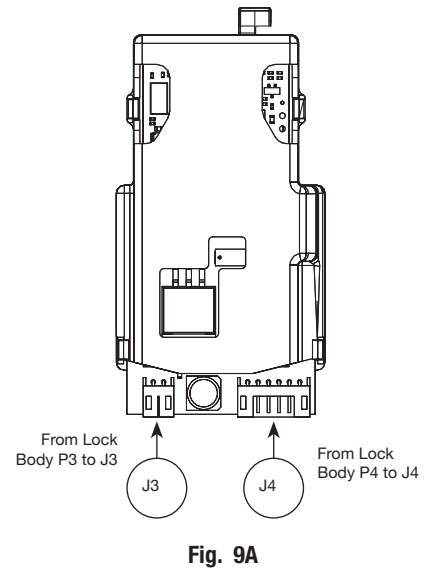



### Step #10 – Installation of Inside Escutcheon

1. Position inside gasket and escutcheon against door. Verify that no wires are being pinched.
2. Mount inside escutcheon assembly to plate using (2) #8-32 x 5/8" Phillips flat head undercut machine screws.

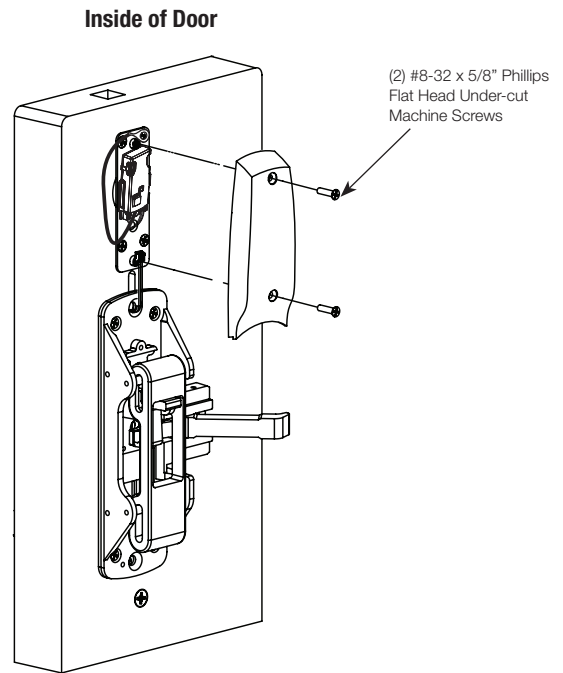

Fig. 10A

### Step #11 – Installation of Rail Assembly

1. Retrieve harness from end of rail. Harness has limited travel and can be damaged.
2. Attach harness to female connector on chassis.
3. Install rail and screws per exit device instructions.

Note: This view shows rim exit device version

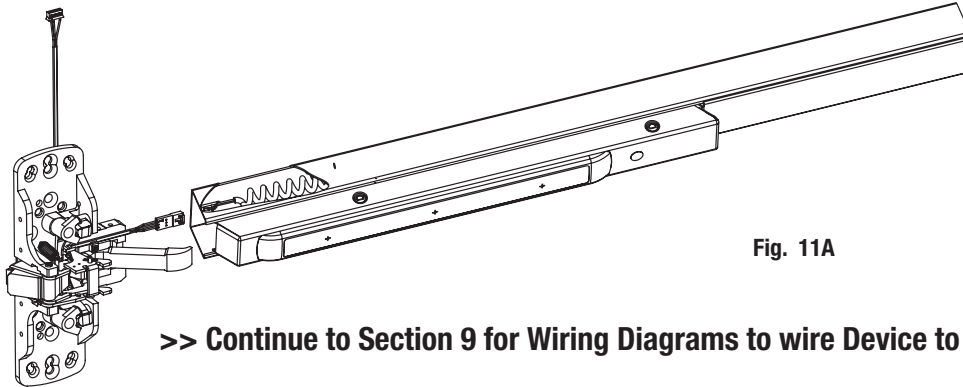

Fig. 11A

>> Continue to Section 9 for Wiring Diagrams to wire Device to EAC Panel. <<

### Step #12 - Concealed Door Position Switch (3287) Instructions

Use SARGENT 3287 Concealed Door Position Switch with this Harmony H2 series product:

1. Install the 3287 Concealed Door Position Switch described in SARGENT document A7448B.
2. Wire the 3287 Concealed Door Position Switch to the EAC door position input.
3. Connect the common wire of the switch to the common input terminal of the EAC; and the normally open wire of the switch to the normally open input terminal of the EAC.

Lock is 12VDC.  
Optional 24VDC lock is available.

McKinney QC12 Hinge

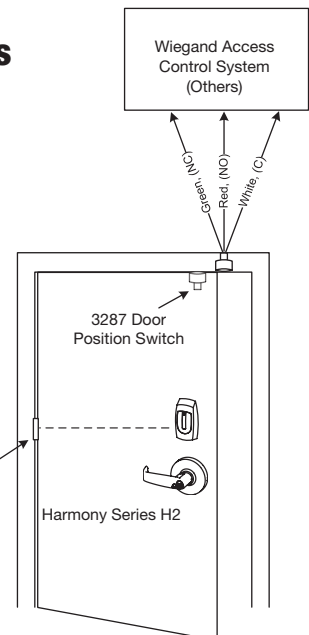

Fig. 12A

## 8 Wiring Diagrams

Product	8 PIN CONNECTOR								4 PIN CONNECTOR			
	1-Black	2-Red	3-White	4-Green	5-Orange	6-Blue	7-Brown	8-Yellow	9-Violet	10-Gray	11-Pink	12-Tan
ACCESS CONTROL DEVICES: Harmony H2 Exits, ElectroLynx wire Color / Function assignments												
	12/24VDC (Reader)		WIE-GAND	WIE-GAND	RX	RX	EGND	LED	12 OR 24 VDC (LOCK RELAY)		DPS (NC)	DPS (COM)
SARGENT - HARMONY SERIES, H2 Exits	NEG	POS	DATA_1	DATA_0	NO	COM	EGND	REF *DIA-GRAMS	NEG	POS	N/A	N/A

\*Diagrams on following pages

### Reader LED Configuration

The Harmony Series reader can be configured for (3) modes of LED operation. HID Programming cards are supported to configure the behavior for LED color activity. Call 1-800-WIRE for details.

#### Mode 1:

- Red LED 'ON' when powered.
- Presenting a 13.56MHz credential causes LED to 'FLICKER' green and return to red state.
- Reference \*Diagram #1 as a function of power requirement (12VDC or 24VDC).

Note: LED wire is unconnected.

#### Mode 2:

- Green LED "ON" when powered.
- No Flicker after presenting valid 13.56MHz credential.
- Reference \*Diagram #2 as a function of power requirement (12VDC or 24VDC).

Note: LED wire must be connected to circuit GROUND of the system's power supply.

#### Mode 3:

- EAC Panel controls LED operation.
- Reference \*Diagram #3 as a function of power requirement (12VDC or 24VDC).

Note: Control of LED is a function of the EAC panel equipment (ie. relay) to toggle between green and red.

Note: When LED wire is tied directly into EAC panel relay, no AC signals should be applied on wire or door reader performance will be interfered (\*Diagram #3).

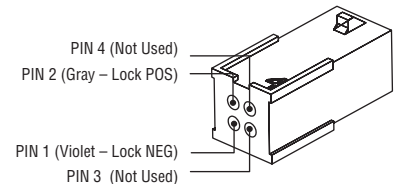
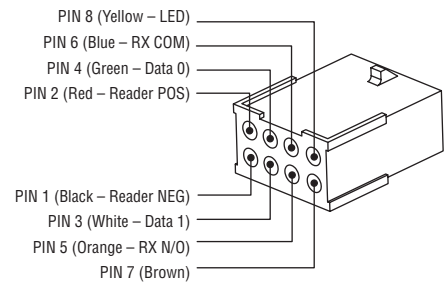

## Typical Harmony Exit Application Diagram (12/24VDC Lock)

### DIAGRAM #1 – MODE 1: RED LED 'ON' WHEN POWERED

#### 12/24VDC SYSTEM

- Reader Draw = 125mA
- 12VDC Solenoid Draw = 500mA
- 12VDC Total Current Draw = 625mA
- 24VDC Solenoid Draw = 250mA
- 24VDC Total Current Draw = 375mA

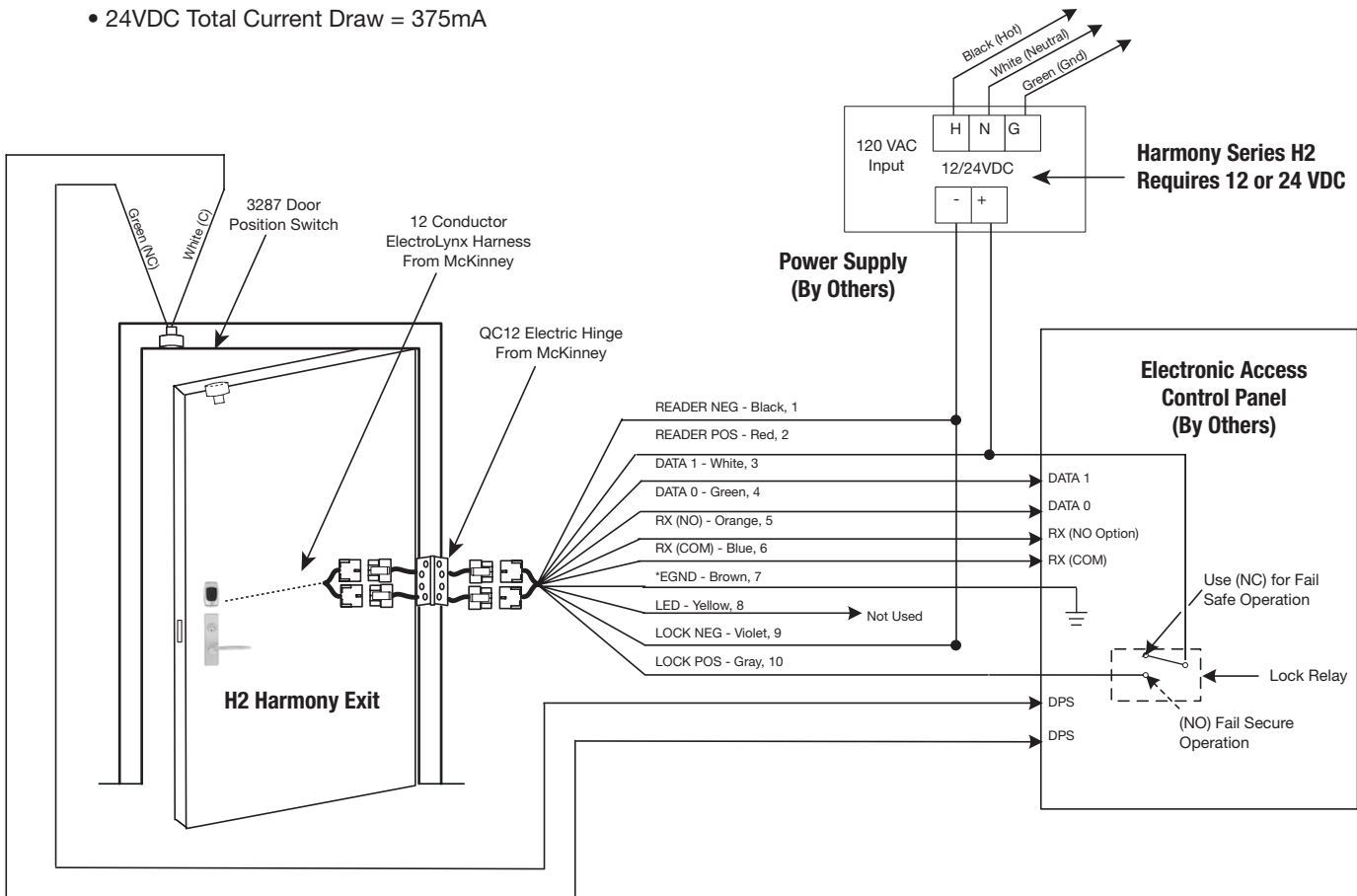

\*IMPORTANT: Pin 7 must be tied to earth ground in the access control panel.

Failure to follow proper ESD safe grounding procedures could lead to equipment failure.

## Typical Harmony Exit Application Diagram (12/24VDC Lock)

### DIAGRAM #2 – MODE 2: GREEN LED ‘ON’ WHEN POWERED

#### 12/24VDC SYSTEM

- Reader Draw = 125mA
- 12VDC Solenoid Draw = 500mA
- 12VDC Total Current Draw = 625mA
- 24VDC Solenoid Draw = 250mA
- 24VDC Total Current Draw = 375mA

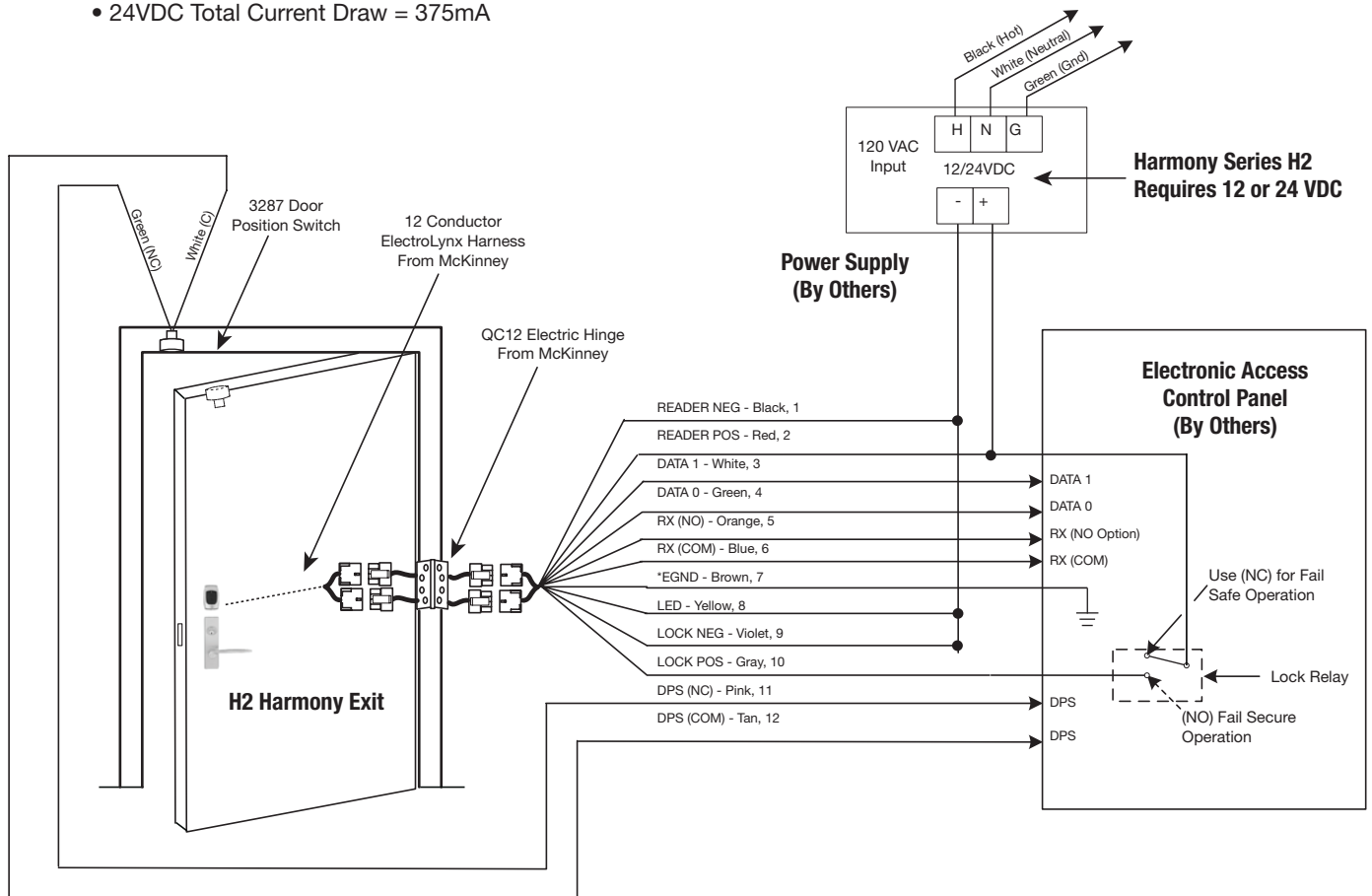

\*IMPORTANT: Pin 7 must be tied to earth ground in the access control panel.

Failure to follow proper ESD safe grounding procedures could lead to equipment failure.

Copyright © 2009 Sargent Manufacturing Company, an ASSA ABLOY Group company. All rights reserved. Reproductions in whole or in part without express written permission of Sargent Manufacturing Company is prohibited.

06/30/09

## Typical Harmony Exit Application Diagram (12/24VDC Lock)

### DIAGRAM #3 – MODE 3: EAC PANEL CONFIGURABLE

#### 12/24VDC SYSTEM

- Reader Draw = 125mA
- 12VDC Solenoid Draw = 500mA
- 12VDC Total Current Draw = 625mA
- 24VDC Solenoid Draw = 250mA
- 24VDC Total Current Draw = 375mA

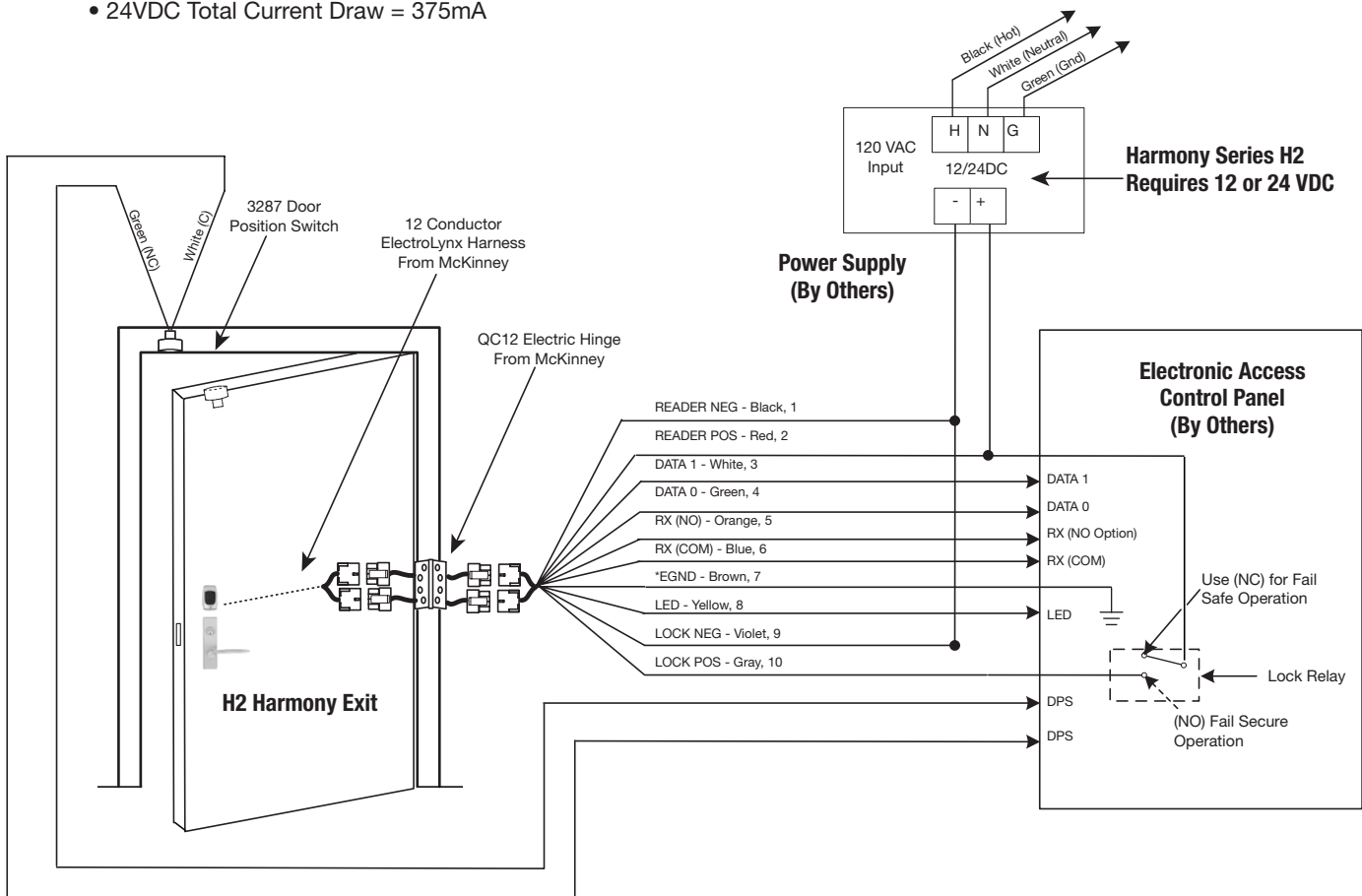

\*IMPORTANT: Pin 7 must be tied to earth ground in the access control panel.

Failure to follow proper ESD safe grounding procedures could lead to equipment failure.

### 10 Mechanical Operational Check

For devices without cylinders, go to step 3.

1. For devices with cylinders, insert key into cylinder and rotate.
2. The key will retract the latch and rods, the key should rotate freely.
3. Depress inside rail to retract latch and rods.

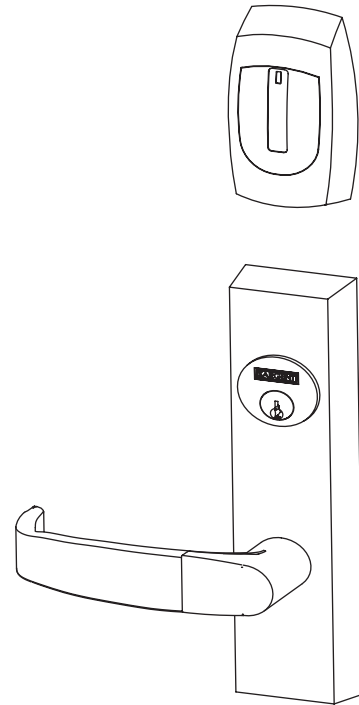

### 11 Electrical Operational Check

Note: Once electrical wiring has been successfully completed according to proper application, follow the following step:

1. Turn power ON.
2. Verify LED located on reader is ON - red or green, depending on reader configuration (see reader LED configuration).
3. Present credential and verify LED and sounder activity.
4. Verify valid card read at EAC Panel.
5. Verify system operation functions; i.e., when credential is presented to reader that the door unlocks.

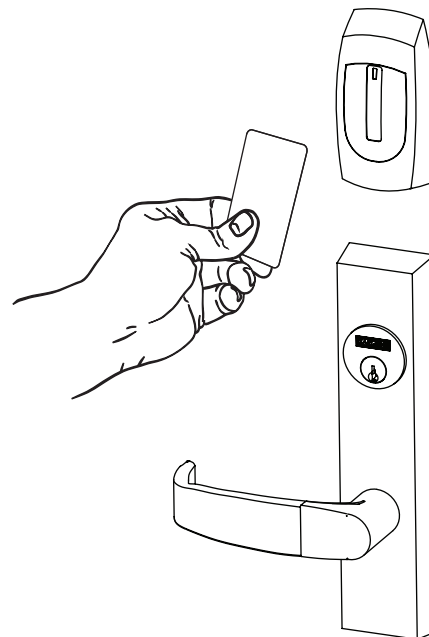

SARGENT  
100 Sargent Drive  
New Haven, CT 06511 USA  
800-481-8464 • [www.sargentlock.com](http://www.sargentlock.com)

Founded in the early 1800s, SARGENT® is a market leader in locksets, cylinders, door closers, exit devices, electro-mechanical products and access control systems for new construction, renovation, and replacement applications. The company's customer base includes commercial construction, institutional, and industrial markets.

Copyright © 2009, Sargent Manufacturing Company, an ASSA ABLOY Group company. All rights reserved. Reproduction in whole or in part without the express written permission of Sargent Manufacturing Company is prohibited.

ASSA ABLOY is the global leader in door opening solutions, dedicated to satisfying end-user needs for security, safety and convenience.