

LoRaWAN RTU Module

By Adeunis

User Guide Version 1.0

Document revision			
Version	Date	Author	Comment
1.0	20/07/2019	EMT	Initial release

ADEUNIS

283 rue Louis Néel - Parc Technologique Pré Roux 38920 CROLLES - France
Tel. : +33 (0)4 76 92 07 77 - Fax : +33 (0)4 76 04 80 87
www.adeunis.com arf@adeunis.com

Information

Document information

Title	LoRaWAN RTU by Adeunis
Subtitle	User Guide Version 1.0
Document type	User Guide
Document status	

This document applies to the following products

Name	Reference	Firmware version
RTU LoRa module	ARF8133A	V1.07.01

Table of contents

DOCUMENT INFORMATION	2
TABLE OF CONTENTS.....	3
DISCLAIMER.....	4
TECHNICAL SUPPORT.....	5
ENVIRONMENTAL RECOMMENDATIONS.....	5
WARNINGS	5
COMPLIANCE TO FCC US/CAN.....	7
TECHNICAL SPECIFICATIONS	10
<i>ARF8133A – US902-928(US) / AU915-928, AS923(AUS/NZ) module</i>	<i>10</i>
DEVICE OVERVIEW.....	11
DEVICE DESCRIPTION	11
RTU MODULE PINING.....	11
1 RTU MODULE HARDWARE INTERFACE	12
1.1 HARDWARE INTERFACE.....	12
1.1.1 <i>RTU interface</i>	<i>12</i>
1.1.2 <i>RTU signal description</i>	<i>13</i>
1.2 SERIAL INTERFACE PROTOCOL.....	13
1.2.1 <i>Command format</i>	<i>13</i>
1.2.2 <i>Implemented commands</i>	<i>15</i>
1.2.3 <i>Command execution time of RTU module</i>	<i>15</i>
2 RTU FEATURES MODE DESCRIPTION	16
2.1 RTU STATE MACHINE.....	16
2.1.1 <i>State diagram</i>	<i>16</i>
2.1.2 <i>Idle and Nominal mode.....</i>	<i>16</i>
2.1.3 <i>Command mode</i>	<i>16</i>
2.2 RTU APPLICATION INTERFACE IN COMMAND MODE	17
2.2.1 <i>AT commands</i>	<i>17</i>
2.3 RTU APPLICATION INTERFACE IN NOMINAL MODE.....	18
2.3.1 <i>Application commands: APPLICATION → RTU</i>	<i>18</i>
2.3.2 <i>Enter command mode command</i>	<i>23</i>
2.3.3 <i>Indication commands: RTU → APPLICATION.....</i>	<i>24</i>
3 ANNEX 1	27

DISCLAIMER

This document and the use of any information contained therein, is subject to the acceptance of the Adeunis RF terms and conditions. They can be downloaded from www.adeunis.com.

Adeunis makes no warranties based on the accuracy or completeness of the contents of this document and reserves the right to make changes to specifications and product descriptions at any time without notice.

Adeunis reserves all rights to this document and the information contained herein. Reproduction use or disclosure to third parties without express permission is strictly prohibited. Copyright © 2016, Adeunis. Adeunis is a registered trademark in the EU and other countries.

All rights to this manual are the exclusive property of ADEUNIS All rights reserved. Copying this manual (without written permission from the owner) via printing, copying, recording or by any other means, translating this manual (in full or partially) into any other language, including all programming languages, using any electrical, mechanical, magnetic or optical devices, manually or any by other methods, is prohibited.

ADEUNIS reserves the right to change the technical specifications or functions of its products, or to cease manufacturing any of its products, or to cease technical support for one of its products without notice in writing and urges its customers to make sure that the information they have is valid.

ADEUNISF configuration software and programs are available free of charge in a non-modifiable version. ADEUNISF can make no guarantees, including guarantees concerning suitability and applicability for a certain type of application. Under no circumstances can the manufacturer, or the distributor of an ADEUNIS RF program, be held liable for any damage caused by the use of the aforesaid program. Program names, as well as all copyright relating to programs, are the exclusive property of ADEUNIS. Any transfer, granting of licenses to a third party, leasing, hire, transport, copying, editing, translation, modification into another programming language or reverse engineering are prohibited without ADEUNIS's prior written authorization and consent.

ADEUNIS
283, rue Louis Néel
38920 Crolles France

Telephone +33 (0)4 76 92 07 77
Fax +33 (0)4 76 04 80 87

Technical Support

Website

Our website contains much useful information: modules and stand-alone products information, user guides, configuration software and technical documents which can be accessed 24 hours a day.

Email

If you have technical problems or cannot find the required information in the provided documents, contact our Technical Support by email. Use our dedicated email address (arf@adeunis.com) rather than any personal email address of our staff. This makes sure that your request is processed as soon as possible.

Helpful Information when Contacting Technical Support

When contacting Technical Support please have the following information ready:

- Product type (e.g. Wireless M-Bus),
- Firmware version (e.g. V3.03)
- Clear description of your question or the problem
- A short description of the application
- Your complete contact details

Environmental recommendations

All superfluous packaging materials have been eliminated. We have done everything possible to make it easy to separate the packaging into three types of materials: cardboard (box), expanded polystyrene (filler material) and polyethylene (packets, foam protective sheets). Your device is composed of materials that can be recycled and reused if it is dismantled by a specialist company. Please observe local regulations concerning the manner in which waste packaging material, used batteries and your obsolete equipment are disposed of.

Warnings

Valid for the following product:
ARF8133A



Read the instructions in the manual



The safety of this product is only guaranteed when it is used in accordance with its purpose. Maintenance should only be carried out by qualified persons.



Please note, do not install the equipment close to a heat source or in damp conditions.



Warning: Do not open the product, risk of electric shock.



Please note: for your own safety, you must ensure that equipment is switched off before carrying out any work on it.

Recommendations regarding use

- Before using the system, check that the power supply voltage shown in the user manual corresponds to your supply. If it doesn't, please consult your supplier.
- Place the device against a flat, firm and stable surface.
- The device must be installed in a location that is sufficiently ventilated so that there is no risk of internal heating and it must not be covered with objects such as newspapers, cloths, curtains, etc.
- The device's aerial must be free and at least 10 cm away from any conducting material.
- The device must never be exposed to heat sources such as heating equipment.
- Do not place the device close to objects with naked flames such as lit candles, blowtorches, etc.
- The device must not be exposed to aggressive chemical agents or solvents likely to damage the plastic or corrode the metal parts.
- Install your device close to its DC power supply.

COMPLIANCE TO FCC US/CAN

Important regulatory information

FCC ID : U3Z-ARF8133

IC : 7016A-ARF8133

• This device complies with part 15 of the FCC rules and Industry Canada license-exempt RSS standard(s). Operation is subject to the following two conditions : (1). this device may not cause Harmful interference, and (2).this device must accept any interference received, including interference that may cause undesired operation of the device.

This equipment has been tested and found to comply with the limits for a Class B digital device, pursuant to part 15 of the FCC Rules. These limits are designed to provide reasonable protection against harmful interference in a residential installation.

This equipment generates, uses and can radiate radio frequency energy and, if not installed and used in accordance with the instruction, may cause harmful interference to radiocommunication. However, there is no guarantee that interference will not occur in a particular installation. If this equipment does cause harmful interference to radio or television reception, which can be determined by turning the equipment OFF

and ON, the user is encouraged to try to correct the interference by one or more of the following measures :

- Reorient or relocate the receiving antenna.
 - Increase the separation between the equipment and receiver.
 - Connect the equipment into an outlet on a circuit different from that to which the receiver is connected.
 - Consult the dealer or an experienced radio/TV technician for help.
- CHANGES OR MODIFICATIONS NOT EXPRESSLY APPROVED BY ADEUNIS COULD VOID THE USER'S AUTHORITY TO OPERATE THE EQUIPMENT.

Under Industry Canada regulations, this radio transmitter may only operate using an antenna of a type and maximum (or lower) gain approved for the transmitter by Industry Canada. To reduce potential radio interference to other users, the antenna type and its gain should be chosen so that the equivalent isotropically radiated power (e.i.r.p.) is not superior than necessary for successful communication.

WARNING ! **FOR MOBILE DEVICE USAGE**

This radiation element complies with FCC RF radiation exposure limits set forth for general population. This radiation element must be installed to provide a separation distance of at least 20cm from all persons and must not be co-located or operating in conjunction with any other antenna or transmitter.

To reduce potential radio interference to other users, the antenna type and its gain should be so chosen that the equivalent isotropically radiated power (e.i.r.p.) is not more than that permitted for successful communication.”

This device has been designed to operate with the antennas listed below, and having a maximum gain of 6 dBi. Antennas not included in this list or having a gain greater than 6 dBi are strictly prohibited for use with this device. The required antenna impedance is 50 ohms.”

MobileMark	PSKN3-925S	3 dBi gain	dipole (see Annex1 for technical detail)
Adeunis		0 dBi+/-2dBgain	PCB Antenna(see Annex1 for technical detail)

OEM Installation and Compliance Labeling

The ARF8133A module is labeled with its own FCC ID number, and, if the FCC ID is not visible when the module is installed inside another device, then the outside of the device into which the module is installed must also display a label referring to the enclosed transmitter module.

This exterior label can use wording such as the following:

“Contains Transmitter Module	Contains FCC ID: U3Z-ARF8133
	Contains IC : 7016A-ARF8133

Any similar wording that expresses the same meaning may be used. The Grantee may either provide such a label, an example of which must be included in the application for equipment authorization, or, must provide adequate instructions along with the module which explain this requirement. In the latter case, a copy of these instructions must be included in the application for equipment authorization.

Information réglementaire importantes

FCC ID : U3Z-ARF8133

IC : 7016A-ARF8133

Ce dispositif est conforme aux règles de la FCC part 15 and à la norme CNR-210 d'Industrie Canada applicable aux appareils radio exempts de licence. Son fonctionnement est sujet aux deux conditions suivantes : (1) le dispositif ne doit pas produire de brouillage préjudiciable, et (2) ce dispositif doit accepter tout brouillage reçu, y compris un brouillage susceptible de provoquer un fonctionnement indésirable.

Cet équipement a été testé et déclaré conforme aux limites d'un appareil numérique de classe B, conformément à la partie 15 des règles de la FCC. Ces limites sont conçues pour fournir une protection raisonnable contre les interférences nuisibles dans une installation résidentielle. Cet équipement génère, utilise et peut émettre de l'énergie radiofréquence et, s'il n'est pas installé et utilisé conformément aux instructions, peut causer des interférences nuisibles aux radiocommunications. Il est cependant toujours possible que des interférences se produisent dans le cadre d'une installation particulière.

Si cet appareil produit des interférences nuisibles à la réception des programmes de radio et de télévision –détectables lors de la mise hors tension ou en tension de l'appareil-l'utilisateur est encouragé à mettre en œuvre une ou plusieurs des mesures suivantes pour remédier à ces interférences :

- Réorienter ou déplacer l'antenne de réception.
- Augmenter la distance entre l'équipement et le récepteur.
- Branchez le matériel à une sortie sur un circuit différent de celui auquel le récepteur est branché.
- Prendre conseil auprès du commerçant ou d'un technicien de radio/TV expérimenté.

Tout changement ou modification non expressément approuvé par la partie responsable des mesures de conformité peut amener l'utilisateur à se voir interdire l'usage de l'appareil.

Cet appareil est limité à l'exploitation des fréquences autorisées Partie 15, et ne peut pas être configuré par des utilisateurs finaux ou des installateurs professionnels à fonctionner en dehors des bandes autorisées.

Conformément à la réglementation d'Industrie Canada, le présent émetteur radio peut fonctionner avec une antenne d'un type et d'un gain maximal (ou inférieur) approuvé pour l'émetteur par Industrie Canada. Dans le but de réduire les risques de brouillage radioélectrique à l'intention des autres utilisateurs, il faut choisir le type d'antenne et son gain de sorte que la puissance isotrope rayonnée équivalente (p.i.r.e.) ne dépasse pas l'intensité nécessaire à l'établissement d'une communication satisfaisante.

ATTENTION !

POUR UTILISATION DE DISPOSITIF MOBILE

L'élément radio est conforme aux limites d'exposition aux rayonnements RF de la FCC établies pour la population générale. L'élément radio doit être installé de manière à assurer une distance de séparation d'au moins 20 cm de tout personnes et ne doivent pas être co-localisés ou fonctionner en conjonction avec toute autre antenne ou émetteur.

Pour réduire le brouillage radioélectrique potentiel causé aux autres utilisateurs, le type d'antenne et son gain doivent être choisis de manière à ce que la puissance rayonnée isotropiquement équivalente (par exemple) ne soit pas supérieure à celle autorisée pour une communication réussie. "

Cet appareil a été conçu pour fonctionner avec les antennes répertoriées ci-dessous et avec un gain maximal de 6 dBi. Les antennes ne figurant pas dans cette liste ou ayant un gain supérieur à 6 dBi sont strictement interdites d'utilisation avec cet appareil. L'impédance d'antenne requise est de 50 ohms. "

MobileMark PSKN3-925S Dipôle à gain de 3 dBi (Voir Annex1 for le détail technique)

Antenne PCB Adeunis 0 dBi +/- 2dBgain (Voir Annex1 for le détail technique)

L'installation OEM et étiquetage de conformité

Le module ARF8133A est étiqueté avec son propre numéro d'identification FCC. Si l'ID FCC n'est pas visible lorsque le module est installé dans un autre périphérique, l'extérieur du périphérique sur lequel il est installé doit également afficher une étiquette faisant référence au module.

Cette étiquette extérieure peut utiliser les libellés suivants:

"Contains Transmitter Module" Contient le FCC ID: U3Z-ARF8133
 Contient IC : 7016A-ARF8133

Toute formulation similaire exprimant le même sens peut être utilisée. Le bénéficiaire peut soit fournir une telle étiquette,

dont un exemple doit être inclus dans la demande d'autorisation d'équipement, soit fournir des instructions adéquates ainsi que le module qui explique cette exigence. Dans ce dernier cas, une copie de ces instructions doit être incluse dans la demande d'autorisation d'équipement

Technical specifications

ARF8133A – US902-928(US) / AU915-928, AS923(AUS/NZ) module

Technical specifications	
Communication	Lora Protocol
Module configuration	Through AT commands
UART configuration	115.2 kbps/N/8/1
Frequency channels	ISM band 902-928MHz (US)
RF output power	20dBm (100mW)
Sensitivity	down to -135dBm
Operating range (Line Of Sight)	Up to 10km
Operating temperature	-30°C / +70°C
Standard compliance	FCC - Title 47 CFR Part 15, RSS - 247 Issue 2

Device Overview

Device Description

The **LoRa RTU module by ADEUNIS** is a ready to use system, which provides connection to any operated network using the LoRaWAN protocol. It allows transmitting, receiving and instantly viewing the radio frames on the used network.

RTU module pinning

ARF8133A
US902-928, AU915, AS923

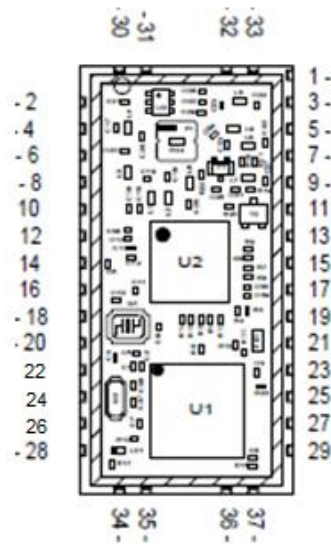

1 – GND
2 – GND
3 – ANTENA
4 – VCC
5 – GND
6 – NC
7 – /RESET
8 – NC
9 – BOOT
10 – UART TX
11 – NC
12 – UART RX
13 – NC
14 – NC
15 – NC
16 – NC
17 – NC
18 – GND
19 – GND
20 – VCC

21 – Uplink trigger
22 – TP1
23 – Downlink trigger
24 – NC
25 – NC
26 – RTU READY
27 – TP2
28 – GND
29 – TP3
30 – GND
31 – GND
32 – GND
33 – GND
34 – GND
35 – GND
36 – GND
37 – GND

1 RTU module hardware interface

1.1 Hardware interface

1.1.1 RTU interface

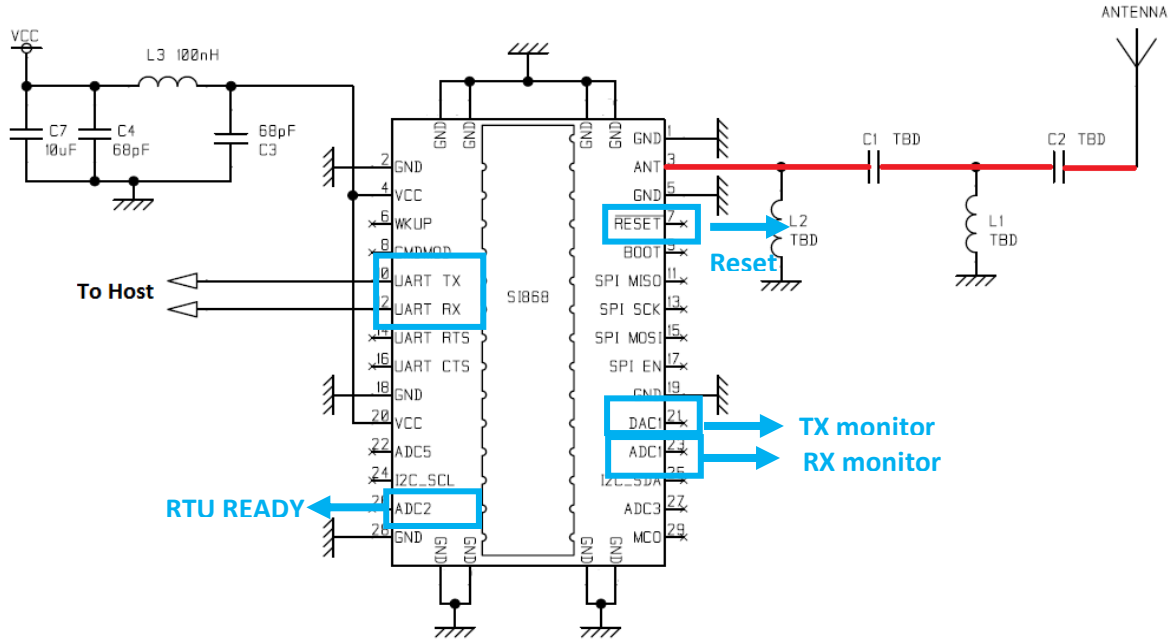

Figure 1: Radio module

Pin	Function	description
6	Class C exit input Specific to LoRa	Pulled-up to VCC Steady state = 1 1 = do nothing 0 = Exit class C
7	Reset	Pulled up to VCC Steady state = 1 1 = do nothing 0 = reset module
10	UART TX	/
12	UART RX	/
21	TX-Uplink monitor Signal that indicates if an UL is in progress	READ ONLY Steady state = 0 1 = uplink in progress 0 = no uplink in progress
23	RX – downlink monitor Signal that indicates if an DL is in progress	READ ONLY Steady state = 0 1 = Rx window opened 0 = Rx window closed
26	RTU READY Indicate if module is ready to receive commands on UART	READ ONLY Steady state = 1 1 = RTU ready 0 = RTU busy

UART Configuration:

- Data rate: 115.2 kbps,
- Data size : 8 bits
- Parity : None

- Stop bit : 1 bit

In exploitation mode, UART is in charge of exchanging data to transmit (UPLINK), data to receive (DOWNLINK), + some other internal data and traces (DEBUG, LoRaWAN, etc..)

Before exchanging UART frame, one or several WakeUp character could be emitted by the RTU module. This number of wake up character is configurable (Register S2xx)

1.1.2 RTU signal description

1.1.2.1 Reset signal

The reset signal allows a complete reset of the RTU module.

1.1.2.1 RTU ready signal

This signal is used to indicate to the host microcontroller if RTU module is ready for reception of new command. When the signal is low, data sent on the UART of the module are ignored. Each time a new command is transmitted to the RTU, this signal goes low until the end of the command processing. After an Uplink command request, RTU Ready stays low for the complete IoT cycle. In that case, the duration may be very long (many seconds).

1.1.2.1 TX Uplink / RX Downlink signals

These two signals are signals frame activated at uplink (RF transmission) and downlink (RF reception) during IoT cycle.

1.1.2.1 UART Tx an UART Rx signals

These two signals allow UART communication to support the serial interface protocol. UART TX is an output of the RTU module, UART Rx is an input.

1.2 Serial interface protocol

This protocol will be used for manage the communication between the application and the RTU module and vice versa.

1.2.1 Command format

Frame format little endian → LSByte first

1.2.1.1 Command

[WKUP] / SOF / LENGTH / CMD / [OPTIONS] / [DATAS] / [CRC]

WKUP: wakeup characters (optional)

- N bytes '0xFF'

SOF: Start Of Frame: 2 bytes = 0x01FF (LSB First)

LENGTH: indicates size of frame including CMD, OPTIONS and DATAS, excluding CRC

- 1 byte: (0x01 to 0xFF) = f(CMD)

CMD: Command

- 1 octet

OPTIONS: depends on CMD (optional)

DATAS: depends on CMD (optional)

CRC: 4 bytes depends on CMD (optional)

1.2.1.2 Acknowledge - Command answer

Acknowledge is always sent after receiving an application command → → Application commands:
APPLICATION (RTU

Acknowledge is always expected after transmitting an application firmware upgrade command → F4 / AF1 / AF2 – Application µc firmware upgrade

[WKUP] / SOF / LENGTH / CMD / ACK / [DATA] / [CRC]

WKUP: wakeup characters (optional)

- N bytes '0xFF'

SOF: Start Of Frame: 2 bytes = 0x01FF (LSB First)

LENGTH: following frame bytes number: 1 bytes = 0x02 to 0xFF

CMD: 1 byte: 0xFF if unknown command else received CMD

ACK: Acknowledge: 1 byte

- 0x06 → ACK
- 0x15 → NACK

DATA: [OPTIONNEL] only if ACK

CRC: 4 bytes depends on CMD (optional)

1.2.2 Implemented commands

Command code	Description	Type	Acknowledgement	CRC
Application to RTU Commands (Application command)				
0x00	Reset RTU module	LoRa	Yes	No
0x01	Start RTU module	LoRa	Yes	No
0x02	Stop RTU module	LoRa	Yes	No
0x03	JOIN request	LoRa	Yes	No
0x04	Uplink request	LoRa	Yes	No
0x05	Application power supply voltage	LoRa	Yes	No
0x06	RTU module power supply voltage	LoRa	Yes	No
0x08	Get LoRaWan parameters	LoRa	Yes	No
0xFE	Enter command mode	LoRa	Yes	No
0x09-0xFD	RFU			
RTU to Application Commands (Indication command)				
0x00	Downlink message	LoRa	No	No
0x01	Trace message	LoRa	No	No
0x02	Uplink configuration message	LoRa	No	No
0x03	Power fail message	LoRa	No	No
0x04	Join done message	LoRa	No	No
0x05	Reception window opening	LoRa	No	No
0x08-0xFC	RFU			
0xFE	Init Done	LoRa	No	No
0xFF	RFU			

1.2.3 Command execution time of RTU module

This chapter is only for APPLICATION module command sent to RTU module with Acknowledgment mechanism.

The command execution time will be indicated through pin RTU_READY maintained in low state position during the time of command execution. This time depends on the command to execute.

2 RTU features mode description

2.1 RTU State Machine

2.1.1 State diagram

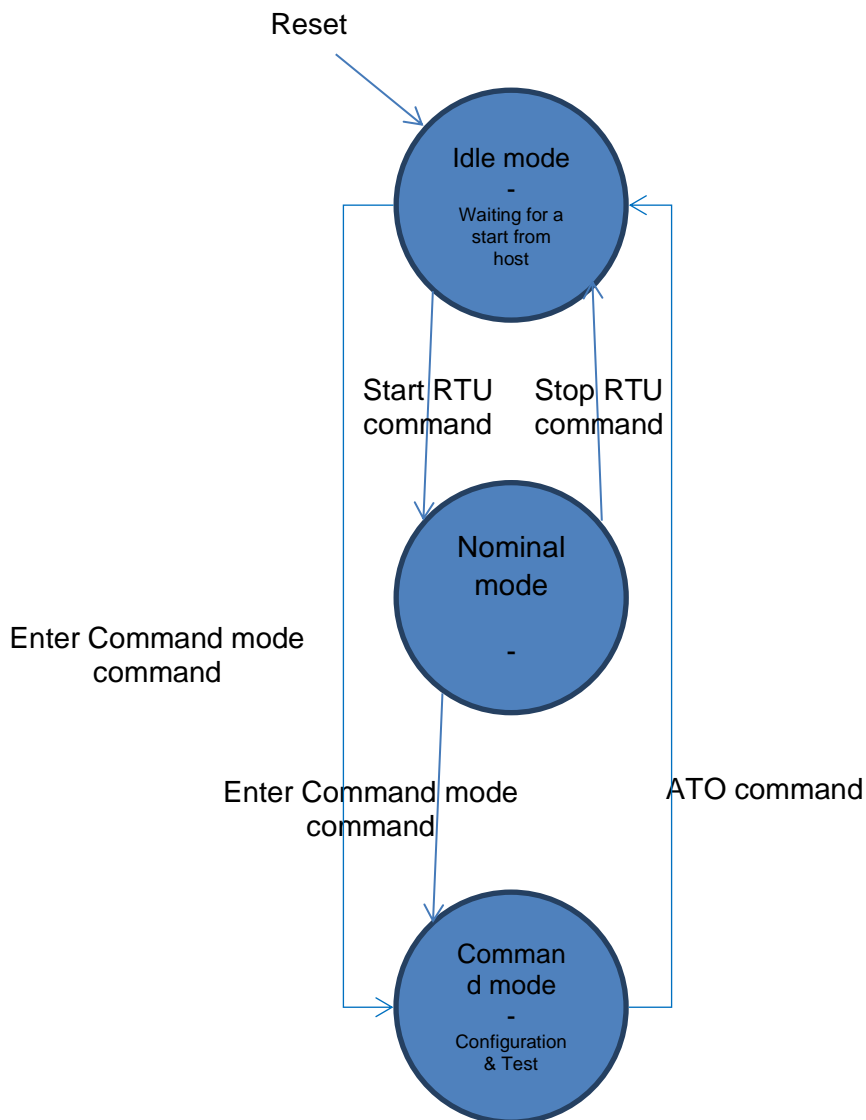

Figure 9: RTU state diagram

2.1.2 Idle and Nominal mode

At powerup or after a reset or the module enter idle mode. To allow IoT communication, the host controller must send the Start RTU command (command code 0x01). In these states, the module reaches ultra low power consumption while there is not command processing. The module is automatically wakeup by the char received on its UART and returns to standby mode after the processing.

2.1.3 Command mode

Command mode is the configuration and test command state of the RTU module. Command mode may be entered from Idle mode or Nominal mode by sending the Enter Command Mode command (command code 0xFE). In this mode, the RTU is not standby so there is no power saving while the module stays in this state. The command format is based on AT style command which is an ASCII oriented format.

2.2 RTU Application interface in Command mode

2.2.1 AT commands

2.2.1.1 Change command execution level

This command must be called before using ATT10 or ATT24 command to change the execution level of the module.

Command format:

'ATT63 ROOT'<CR>

Command answer:

'O'<CR><LF> for OK if command succeeds, 'E'<CR><LF> for error if command is rejected

2.2.1.2 RF carrier command

This command places the RF in carrier wave mode.

Command format:

'ATT10'<CR>

Command answer:

'O'<CR><LF> for OK if command succeeds, 'E'<CR><LF> for error if command is rejected

This test is exited on reception of an <ESC> char on UART. The module response is 'O'<CR><LF> on <ESC> reception.

RF carrier command

This command places the RF in modulated carrier mode.

Command format:

'ATT14'<CR>

Command answer:

'O'<CR><LF> for OK if command succeeds, 'E'<CR><LF> for error if command is rejected

This test is exited on reception of an <ESC> char on UART. The module response is 'O'<CR><LF> on <ESC> reception.

2.2.1.3 RF reception command

This command places the RF in reception mode.

Command format:

'ATT24'<CR>

Command answer:

'O'<CR><LF> for OK if command succeeds, 'E'<CR><LF> for error if command is rejected.

This test is exited on reception of an <ESC> char on UART. The module response is 'O'<CR><LF> on <ESC> reception.

Char received during this mode (which may correspond to RF data) must be discarded by the host controller.

2.2.1.4 Exit command mode command

This command places the RF in reception mode.

Command format:

'ATO'<CR>

Command answer:

'O'<CR><LF> for OK if command succeeds, 'E'<CR><LF> for error if command is rejected.

The module backs to Idle mode. The AT command interpreter is stopped and the module gets its lowest power consumption.

2.3 RTU Application interface in Nominal mode

This feature allows application to transmit/receive data from IOT network. RTU module provides run time information to application.

2.3.1 Application commands: APPLICATION → RTU

2.3.1.1 Reset command

Reset RTU module

SOF/ LENGTH / CMD

LENGTH: 0x01

CMD: 0x00

2.3.1.2 Start command

Allows to start up RTU module if power supply level is OK

SOF/ LENGTH / CMD

LENGTH: 0x01

CMD: 0x01

Expected answer:

- ACK → SOF / 0x03 / 0x01 / 0x06 / POWERFAIL (1 octet)
 - POWERFAIL != 0 → POWER FAIL, power supply voltage is less than minimum power supply voltage AT register 260 + 200 mV, the module goes back to STOP mode by itself (low power)
 - POWERFAIL = 0 → POWER GOOD, the module goes back to START mode
- NACK → SOF / 0x02 / 0x01 / 0x15

2.3.1.3 Stop command

Stop module.

SOF/ LENGTH / CMD

LENGTH: 0x01

CMD: 0x02

2.3.1.4 JOIN Command - LORA ONLY

Execute a JOIN process if OTAA mode has been activated.
 In ABP mode NetSKey, AppSKey and DevAddr are updated.

- Diagram for OTAA mode

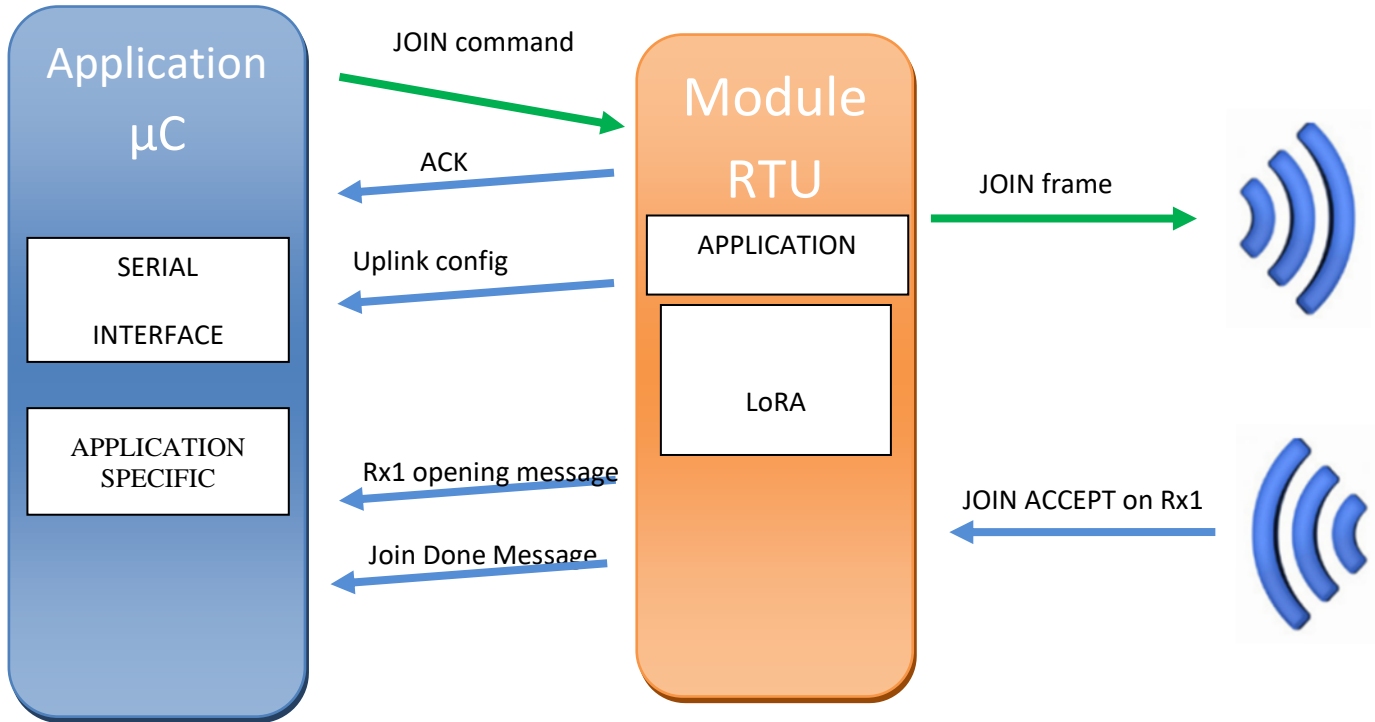

2.3.1.4.1 For ABP mode

There is no join phase in ABP mode, so after the module starting, data can be sent directly.

2.3.1.4.2 Command

SOF/ LENGTH / CMD / DUTYCYCLE

LENGTH: 0x03

CMD: 0x03

DUTYCYCLE: periodical repetition of JOIN process in case of failure (expressed in seconds)

- 2 bytes
- Limit : $10(0x0A) \text{ s} \leq \text{DUTYCYCLE} \leq 2100(0x0834) \text{ s}$
- $\text{DUTYCYCLE} = 0 \rightarrow$ duty cycle manages by application

Note: all DUTYCYCLE value will be allowed but value will be re-evaluated according to defined limits

- $0 < \text{DUTYCYCLE} < 10 \rightarrow$ DUTYCYCLE value set to 10 s
- $\text{DUTYCYCLE} > 2100 \rightarrow$ DUTYCYCLE value set to 2100 s

- Uplink request command

2.3.1.4.3 Diagram

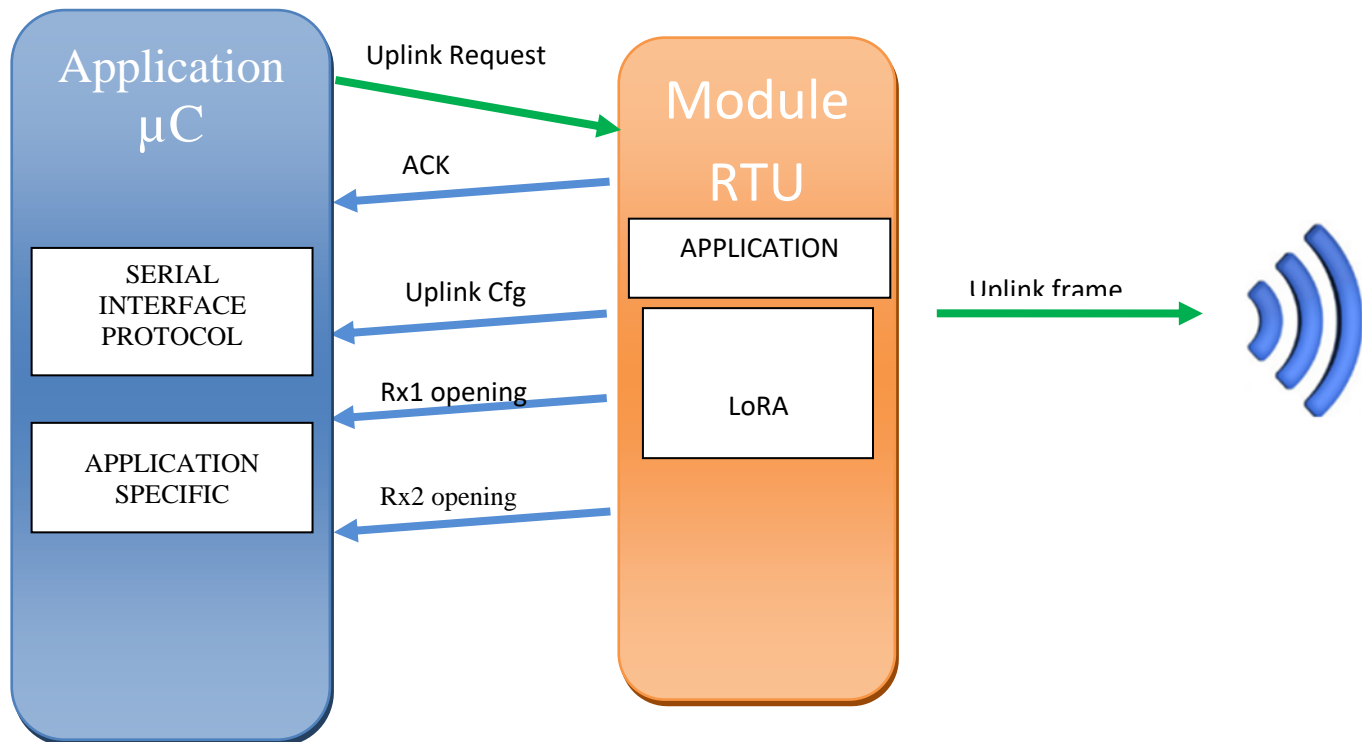

2.3.1.4.4 Command

SOF / LENGTH / CMD / OPTIONS / DATA

LENGTH: following frame bytes number

- LoRaWAN → Max LENGTH = f(DR)

CMD: 0x04

OPTIONS:

- LORA OPTION → CTRL/DR/PORT
 - CTRL
 - Bit 0 → CONFIRMED if 1
 - Bit 1 → LinkCheckReq if 1 (In this case the module sends a MAC command without FRMPayload)
 - Bit<7:2> → Reserved
 - DR : application can set data rate only if Adaptive Data Rate is deactivated (S220 = 0)
 - Symmetric band
 - DR_0 (0x00) → SF12 – 125 kHz
 - DR_1 (0x01) → SF11 – 125 kHz
 - DR_2 (0x02) → SF10 – 125 kHz
 - DR_3 (0x03) → SF9 – 125 kHz
 - DR_4 (0x04) → SF8 – 125 kHz
 - DR_5 (0x05) → SF7 – 125 kHz
 - DR_6 (0x06) → SF7 – 250 kHz
 - DR_7 (0x07) → FSK 50 kbps
 - Asymmetric band
 - DR_0 (0x00) → SF10 – 125 kHz

- DR_1 (0x01) → SF9 – 125 kHz
- DR_2 (0x02) → SF8 – 125 kHz
- DR_3 (0x03) → SF7 – 125 kHz
- DR_4 (0x04) → SF8 – 500 kHz
- PORT: application port
 - 0 → MAC Command
 - LinkCheckReq
 - Proprietary command 0x80 à 0xFF (Not implemented)
 - 1-223 → application port
 - Other value → default port 1

DATA: data to transmit

- LoRaWAN → Max DATA = f(DR)

2.3.1.5 Application power supply voltage command

Application sends to RTU module the application power supply voltage. Since the module does not use application power supply value, this function does not need to be called.

SOF/ LENGTH / CMD / Vbat

LENGTH: 0x03

CMD: 0x05

VBAT: Application power supply voltage expressed in mV: 2 bytes, LSB First

2.3.1.6 RTU module power supply voltage command

Application gets RTU module power supply voltage.

SOF/ LENGTH / CMD

LENGTH: 0x01

CMD: 0x06

Expected answer:

- ACK → SOF / 0x03 / 0x06 / 0x06 / VBAT (2 bytes expressed in mV, LSB First)
- NACK → SOF / 0x02 / 0x06 / 0x15

2.3.1.7 LoRa configuration command – LoRa ONLY

Application gets Get LoRaWAN parameters.

SOF/ LENGTH / CMD

LENGTH: 0x01

CMD: 0x08

Expected answer:

- NACK → SOF / 0x02 / 0x08 / 0x15
- ACK → SOF / 0x6E / 0x08 / 0x06 / NetID (3) / DevAddr (4) / DevClass (1) / OPTIONS (1) / ChFreq1 (4) / ChRange1 (1) / ChFreq2 (4) / ChRange2 (1) / ChFreq3 (4) / ChRange3 (1) / ChFreq4 (4) / ChRange4 (1) / ChFreq5 (4) / ChRange5 (1) / ChFreq6 (4) / ChRange6 (1) / ChFreq7 (4) / ChRange7 (1) / ChFreq8 (4) / ChRange8 (1) / ChFreq9 (4) / ChRange9 (1) / ChFreq10 (4) / ChRange10 (1) / ChFreq11 (4) / ChRange11 (1) / ChFreq12 (4) / ChRange12 (1) / ChFreq13 (4) / ChRange13 (1) / ChFreq14 (4) / ChRange14 (1) / ChFreq15 (4) / ChRange15 (1) / ChFreq16 (4) / ChRange16 (1) / Rx2ChFreq (4) / Rx2DR (1) / RxDelay1 (1) / Rx1DROffset (1) / UplinkCounter (4) / DownlinkCounter (4) / ADRAckCounter (4)

In EU_868 ChFreqX and ChRangeX fields describe uplink/downlink channels.

In XX_915 mode ChFreqX and ChRangeX fields describe reception window 1 channels.

OPTIONS:

- Bit 0 : OTAA if 1, ABP if 0
- Bit 1 : Adaptative Data Rate On if 1
- Bit 2 : Network joined if 1
- Bit 3 : Rx windows settings : Test house if 1 else standard

2.3.2 Enter command mode command

Module enter command mode

SOF/ LENGTH / CMD

LENGTH: 0x01

CMD: 0xFE

Expected answer:

- ACK → SOF / 0x06 / 0xFE / 0x06 / 'C' / 'M' / 0x0D / 0x0A
- NACK → SOF / 0x02 / 0xFE / 0x15

2.3.3 Indication commands: RTU → APPLICATION

These commands provide information from RTU module to application.
No acknowledge needed

2.3.3.1 Downlink information command

- Diagram

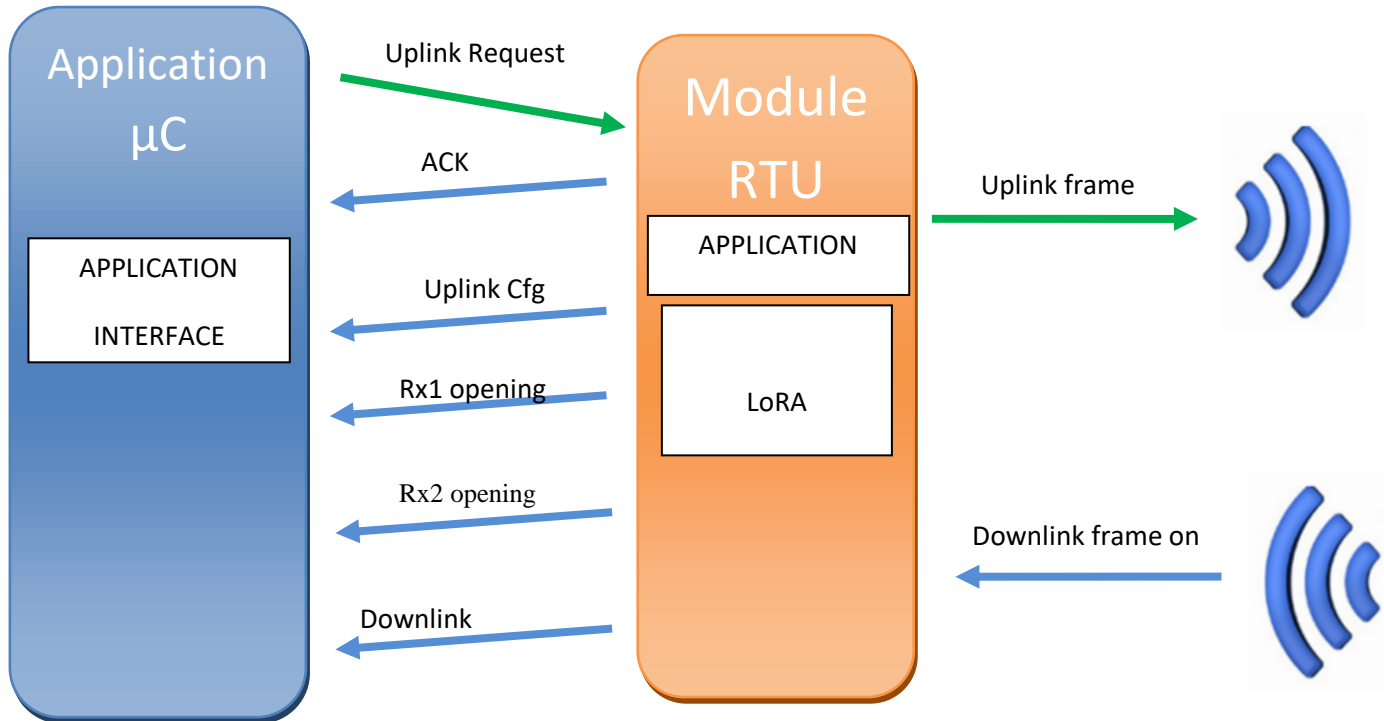

2.3.3.1.1 Command

SOF / LENGTH / CMD / OPTIONS / DATA

LENGTH: following frame bytes number

- LoRaWAN → Max LENGTH = f(DR)

CMD: 0x00

OPTIONS

- LORA : OPTIONS → RXWIN/Freq/DR/RSSI/SNR/CTRL/DL counter/PORT (
 - RXWIN : downlink Rx Window
 - 0x00 → RX1
 - 0x01 → RX2
 - Freq : Rx frequency expressed in Hz (4 bytes)
 - DR : Data rate (1 bytes)
 - Symmetric band: DR_0 to DR_7
 - Asymmetric band: DR_8 to DR_13
 - RSSI: 2 bytes, signed value
 - SNR: 1 byte
 - CTRL
 - Bit 0: Ack if 1
 - Bit 1: linkCheckAns if 1
 - Bit 2: FPending status
 - Bit<7:3>: Reserved
 - DL counter : 16 bits, LSB First

- PORT : 0 to 223 (1 byte)
 - 0 → MAC command (No payload)
 - 1-223 → application port
 - 224 → reserved for compliance test

DATA: downlink data

Note: if bit CTRL-in.linkCheckAns is set to 1 then to bytes are added to data payload

- Margin
- Gateways number

2.3.3.2 Trace command

Trace are encapsulated to be redirect by application if needed.

SOF / LENGTH / CMD / TRACE_DATA

LENGTH: following frame bytes: 0x02 to 0xFF

CMD: 0x01

TRACE_DATA

2.3.3.3 Uplink configuration command

Sends to application before each transmission

SOF / LENGTH / CMD / OPTIONS

LENGTH: 0x19 lora

CMD: 0x02

OPTIONS

- LoRa : OPTIONS → FREQ / BAND / DR / TxPower / TxTimeOnAir / UL counter / CTRL/ Rx1FREQ / Rx1ChannelBand / Rx1DrOffset / Rx2Freq / Rx2Dr / Port
 - FREQ: frequency expressed in Hz (4 bytes, LSB First)
 - BAND : frequency band (1 byte)
 - DR : Data rate (1 byte)
 - Symmetric band
 - DR_0 (0x00) → SF12 – 125 kHz
 - DR_1 (0x01) → SF11 – 125 kHz
 - DR_2 (0x02) → SF10 – 125 kHz
 - DR_3 (0x03) → SF9 – 125 kHz
 - DR_4 (0x04) → SF8 – 125 kHz
 - DR_5 (0x05) → SF7 – 125 kHz
 - DR_6 (0x06) → SF7 – 250 kHz
 - DR_7 (0x07) → FSK 50 kbps
 - Asymmetric band
 - DR_0 (0x00) → SF10 – 125 kHz
 - DR_1 (0x01) → SF9 – 125 kHz
 - DR_2 (0x02) → SF8 – 125 kHz
 - DR_3 (0x03) → SF7 – 125 kHz
 - DR_4 (0x04) → SF8 – 500 kHz
 - TxPower : transmit power expressed in dBm (1 byte)
 - TxTimeOnAir : transmit time on air expressed in ms (2 bytes, LSB First)
 - UL counter : uplink counter (2 bytes, LSB First)
 - CTRL
 - Bit 0 → AckRequested : 1 if confirmed uplink, else 0 (8bits)
 - Bit 1 → Payload not sent if 1 (Only MAC commands were transmitted)
 - Bit 2 → Payload length error if 1 (No transmission)
 - Bit 3 → LoRaMac request error if 1 (No transmission)
 - Bit<7:4> → Reserved

- Rx1Freq : expressed in Hz (4 bytes)
- Rx1ChannelBand : Rx channel band (1 byte)
- Rx1DrOffset : Rx1 datarate offset (1 byte)
- Rx2Freq : Rx window 2 frequency expressed in Hz (4 bytes, LSByte first)
- Rx2Dr : Rx window 2 (1 byte)
- Port : application port (1 byte)

2.3.3.4 Power Fail command

Sends in case of power supply voltage failure. After sending this command RTU module goes to Stop mode.

SOF / LENGTH / CMD

LENGTH: 0x01

CMD: 0x03

2.3.3.5 JOIN done command – LoRa ONLY

During JOIN process if RTU module received a JOIN ACCEPT message, RTU module sends to application a JOIN DONE command.

If no JOIN procedure done when RTU ask to send the first Uplink:

- ➔ in OTAA mode, RTU module initiates independently only one JOIN procedure. RTU module will reply a JOIN DONE upon reception of JOIN ACCEPT. Then it will execute the Uplink . In case of failure of the JOIN, RTU module will give control back to the Application µC.
- ➔ In ABP mode, RTU module will send JOIN DONE before sending the UplinkCfg command

See diagram ➔ [JOIN Command - LORA ONLY](#)

SOF / LENGTH / CMD

LENGTH: 0x01

CMD: 0x04

2.3.3.6 Reception window opening command

Before opening each reception window this command is sent.

SOF / LENGTH / CMD / OPTION

LENGTH: 0x02 lora

CMD: 0x05

OPTIONS:

- LORA : OPTIONS ➔ RX_SLOT
 - RX_SLOT :
 - 0x00 ➔ Rx slot 1
 - 0x01 ➔ Rx slot 2

2.3.3.7 Init Done

This message informs the application that the module has finished initialisation phase (after reset) and is ready to interpret commands. This message replaces the previous “RESET” message.

SOF / LENGTH / CMD

LENGTH: 0x01

CMD: 0xFE

3 Annex 1

Dipole Antenna



Device Antennas, Halfwave, LTE 3G/4G Dual-band, 694-2750 MHz

- Sleek profile with adjustable elbow for straight or angled operation
- Compact design, ground plane independent with high performance
- Can be configured as fixed straight or fixed right angle (prefix PSN or PSNRA)

The PSKN Dual band antennas offer excellent performance and are available for a number of dualband and broadband wireless data applications.

Three different series are available; a model for US Cellular 3G, a model for EU GSM, and a wideband model for US Cellular including GSM/CDMA, LTE & AWS/UMTS.

The EU GSM 925 MHz lower band also covers with the ISM 915 band (902-928 MHz), without any sacrifice in performance. Additionally, a model is available with reverse polarity SMA connector, for use in ISM 915.

The broadband options, PSKN3-700/2100S and PSKN3-700/2700S, cover traditional cellular frequencies as well as the new LTE 700 MHz band and the UMTS bands.

This PSKN series is a “blade” style antenna with an adjustable right angle elbow. Overall length is 7.75” (20 cm) in a straight position, and 6.75” (17.2 cm) in a right angle position. Peak gain on all bands is 3 dBi.

The halfwave design means the antennas are ground-plane independent, the antennas can be used on plastic or metal without concern for proper ground size.

The radome material is a semi-flex polyurethane, providing some give when stressed but maintaining long term durability.

The antennas pass a number of industrial and military shock & vibration standards, and have been rated IPx5 for water ingress. The PSN models are rated IP67.

The antennas are available with SMA, TNC or Reverse Polarity SMA (for 902-928 ISM applications).

Model #	Frequency (MHz)	Connector
US CDMA / GSM / Data		
PSKN3-900/1900T	824-894 & 1850-1990	TNC Plug
PSKN3-900/1900S	824-894 & 1850-1990	SMA Plug
EU GSM & ISM 915		
PSKN3-925/1800S	870-960 & 1710-1880	SMA Plug
PSKN3-925/1800T	870-960 & 1710-1880	TNC Plug
EU GSM & ISM 915 with Rev Pol SMA		
PSKN3-925/1800RS	870-960 & 1710-1880	Rev SMA Plug
Wideband with SMA		
PSKN3-700/2100S	694-960 & 1710-2170	MA Plug
PSKN3-700/2700S	694-960 & 1710-2750	SMA Plug

All Knuckle-Swivel Models (PSKN) Available in Fixed Position: PSN - Straight Fixed Position. PSNRA - Right Angle Fixed Position.

Specifications	
Frequency ranges:	900/1900 824-894 & 1850-1990 MHz 925/1800 870-960 & 1710-1880 MHz 700/2100 694-960 & 1710-2170 MHz 700/2700 694-960 & 1710-2750 MHz
Gain:	3 dBi peak
VSWR:	2:1 max over range
Impedance:	50 Ohm nominal
Maximum Power:	5 Watt
Operating Temp:	-40°C to +85°C
Connector:	SMA Plug (Male), TNC Plug (Male), or Reverse Pol SMA
Whip Length:	6.75” (17.2 cm) at 90° angle, 7.75” (19.7 cm) when straight
Radome Material:	Polyurethane, with black matt finish, and knurled connector.
Shock & Vibration:	EN 61373, IEEE 1478, MIL-810G, TIA-329.2-C
Water Ingress:	IP67 (PSN series) IPx5 (others)
Style:	PSKN Adjustable Straight, Right Angle PSN Fixed Straight PSNRA Fixed Right Angle

PCB ANTENNA

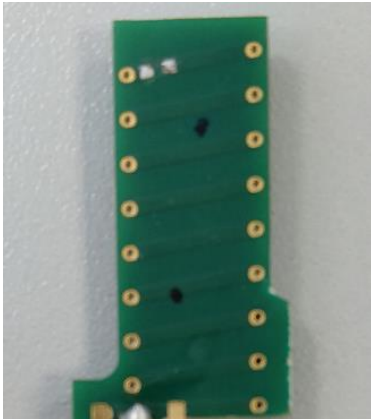

Polarization : Vertical

Gain : 0dB +/-2dB

Realized Gain (gain + efficient): 0dB +/-2dB

Parametre S:

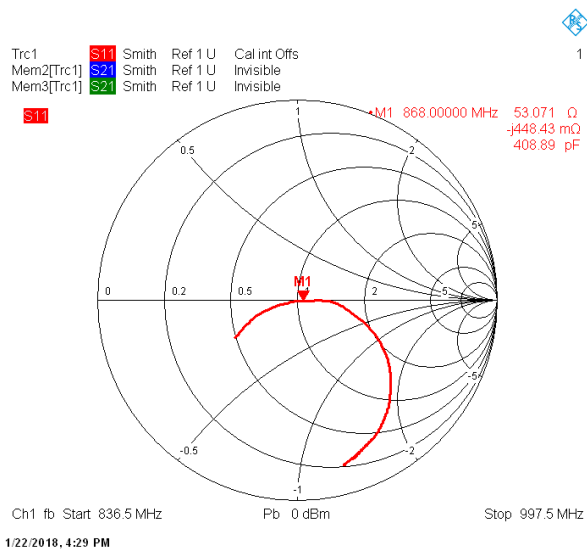

***** END OF DOCUMENT *****