

## TEST REPORT

**Report Number: 102502245MPK-033**

**Project Number: G102502245**

**Original Issue Date: August 05, 2016**

**Revision Issue Date: August 31, 2016**

**Testing performed on  
TripSaver II Controller  
Model: TSII-CONTRL2 and TSII-CONTRL3  
FCC ID: U3D-TSII-CONTRL2**

to

**FCC Part 15 Subpart C (15.247)  
Industry Canada RSS-247 Issue 1  
FCC Part 15, Subpart B  
Industry Canada ICES-003**

For

**S&C Electric Company**

Test Performed by:  
Intertek  
1365 Adams Court  
Menlo Park, CA 94025 USA

Test Authorized by:  
S&C Electric Company  
6601 N Ridge Blvd  
Chicago, IL 60626 USA

Prepared by:

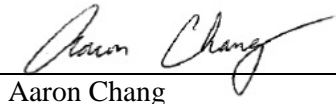
  
Aaron Chang

Date: August 31, 2016

Reviewed by:

  
Krishna K Vemuri

Date: August 31, 2016

*This report is for the exclusive use of Intertek's Client and is provided pursuant to the agreement between Intertek and its Client. Intertek's responsibility and liability are limited to the terms and conditions of the agreement. Intertek assumes no liability to any party, other than to the Client in accordance with the agreement, for any loss, expense or damage occasioned by the use of this report. Only the Client is authorized to copy or distribute this report and then only in its entirety. Any use of the Intertek name or one of its marks for the sale or advertisement of the tested material, product or service must first be approved in writing by Intertek. The observations and test results in this report are relevant only to the sample tested. This report by itself does not imply that the material, product, or service is or has ever been under an Intertek certification program. This report must not be used to claim product endorsement by A2LA, NIST nor any other agency of the U.S. Government.*

## Report No. 102502245MPK-033

**Equipment Under Test:** TripSaver II Controller  
**Trade Name:** TripSaver II Controller  
**Model Number:** TSII-CONTRL2 and TSII-CONTRL3  
**Serial Number:** Conducted Sample:  
FFFFFFFF. FFFFFFFF. FFFFFFFF. FFFFFFFF6  
Radiated Sample:  
0019C900.00020000.00140001.90000047

**Applicant:** S&C Electric Company  
**Contact:** Muhammad Tabani  
**Address:** S&C Electric Company  
6601 N Ridge Blvd  
Chicago, IL 60626

**Country:** USA

**Tel. Number:** (773) 381-1501 Ext 4134  
**Email:** muhammad.tabani@sandc.com

**Applicable Regulation:** FCC Part 15 Subpart C (15.247)  
Industry Canada RSS-247 Issue 1  
FCC Part 15, Subpart B  
Industry Canada ICES-003

**Date of Test:** May 20 – July 29, 2016 (Revision 1.0)  
August 9 – 10, 2016 (Revision 2.0)

*We attest to the accuracy of this report (Revision 1.0):*



Anderson Soungpanya  
Project Engineer



Krishna K Vemuri  
Engineering Team Lead

*We attest to the accuracy of this report (Revision 2.0):*

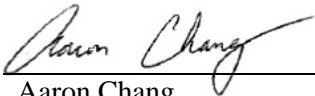

Aaron Chang  
Project Engineer



Krishna K Vemuri  
Engineering Team Lead

## TABLE OF CONTENTS

<b>1.0</b>	<b>Summary of Tests .....</b>	<b>5</b>
<b>2.0</b>	<b>General Information.....</b>	<b>6</b>
2.1	Product Description .....	6
2.2	Related Submittal(s) Grants.....	7
2.3	Test Facility .....	7
2.4	Test Methodology.....	7
2.5	Measurement Uncertainty.....	7
<b>3.0</b>	<b>System Test Configuration.....</b>	<b>8</b>
3.1	Support Equipment .....	8
3.2	Block Diagram of Test Setup.....	8
3.3	Justification.....	9
3.4	Software Exercise Program.....	9
3.5	Mode of Operation during Test.....	9
3.5	Modifications Required for Compliance .....	9
3.6	Additions, Deviations and Exclusions from Standards.....	9
<b>4.0</b>	<b>Measurement Results.....</b>	<b>10</b>
4.1	6-dB Bandwidth and Occupied Bandwidth .....	10
4.1.1	Requirement.....	10
4.1.2	Procedure .....	10
4.1.3	Test Result .....	10
4.2	Maximum Peak Conducted Output Power at Antenna Terminals .....	17
4.2.1	Requirement.....	17
4.2.2	Procedure .....	17
4.3.3	Test Result .....	17
4.3	Maximum Power Spectral Density .....	21
4.3.1	Requirement.....	21
4.3.2	Procedure .....	21
4.3.3	Test Result .....	21
4.4	Unwanted Conducted Emissions .....	25
4.4.1	Requirement.....	25
4.4.2	Procedure .....	25
4.4.3	Test Result .....	25
4.5	Transmitter Radiated Emissions .....	30
4.5.1	Requirement.....	30
4.5.2	Procedure .....	30
4.5.3	Field Strength Calculation .....	31
4.5.4	Antenna-port conducted measurements.....	32
4.5.6	General Procedure for conducted measurements in restricted bands.....	32
4.5.7	Test Results.....	32
4.5.8	Test setup photographs .....	43
4.6	Radiated Emissions.....	45
4.6.1	Requirement.....	45
4.6.2	Procedures.....	46
4.6.3	Test Results.....	46

4.6.4	Test Configuration Photographs .....	48
4.7	AC Line Conducted Emission .....	49
4.7.1	Requirement.....	49
4.7.2	Procedure .....	49
4.7.3	Test Result .....	50
4.6.4	Test Configuration Photographs .....	53
<b>5.0</b>	<b>RF Exposure Evaluation .....</b>	<b>54</b>
<b>6.0</b>	<b>List of Test Equipment .....</b>	<b>55</b>
<b>7.0</b>	<b>Document History .....</b>	<b>56</b>
<b>Appendix A:</b>	<b>Additional testing for model TSII-CONTRL3 .....</b>	<b>57</b>
A.1	Transmitter Radiated Emissions .....	57
A.1.1	Requirement.....	57
A.1.2	Procedure .....	57
A.1.3	Field Strength Calculation .....	58
A.1.4	Antenna-port conducted measurements .....	59
A.1.5	General Procedure for conducted measurements in restricted bands.....	59
A.1.6	Test Results.....	59
A.1.7	Test setup photographs .....	70
A.2	Radiated Emissions.....	72
A.2.1	Requirement.....	72
A.2.2	Procedures.....	73
A.2.3	Test Results.....	73
A.2.4	Test Configuration Photographs .....	75
A.3	AC Line Conducted Emission .....	76
A.3.1	Requirement.....	76
A.3.2	Procedure .....	76
A.3.3	Test Result .....	77
A.3.4	Test Configuration Photographs .....	79

## 1.0 Summary of Tests

Test	Reference FCC	Reference Industry Canada	Result
<b>Radiated Emissions</b>	15.109	ICES-003	Complies
<b>AC Line Conducted Emission</b>	15.107	ICES-003	Complies
<b>RF Output Power</b>	15.247(b)(3)	RSS-247, 5.4.4	Complies
<b>6 dB Bandwidth</b>	15.247(a)(2)	RSS-247, 5.2.1	Complies
<b>Power Density</b>	15.247(e)	RSS-247, 5.2.2	Complies
<b>Out of Band Antenna Conducted Emission</b>	15.247(d)	RSS-247, 5.5	Complies
<b>Transmitter Radiated Emissions</b>	15.247(d), 15.209, 15.205	RSS-247, 5.5	Complies
<b>AC Line Conducted Emission</b>	15.207	RSS-GEN	Complies
<b>Antenna Requirement</b>	15.203	RSS-GEN	Complies (Internal Antenna)
<b>RF Exposure</b>	15.247(i), 2.1093(d)	RSS-102	Complies

**EUT receive date:** May 18, 2016

**EUT receive condition:** The pre-production version of the EUT was received in good condition with no apparent damage. As declared by the Applicant, it is identical to the production units.

**Test start date:** May 20, 2016 (Revision 1.0); August 9, 2016 (Revision 2.0)

**Test completion date:** July 29, 2016 (Revision 1.0); August 10, 2016 (Revision 2.0)

The test results in this report pertain only to the item tested.

## 2.0 General Information

### 2.1 Product Description

(Revision 1.0)

The S&C Electric TripSaver II Controller (Model Number TSII-CONTRL2) is an electronic control module used to control the self-powered S&C TripSaver II (TSII) Cutout-Mounted Recloser. Housed in the TSII, the control module processes all electronic / electrical functions required for the proper operation of the TSII. Aside from its primary functions, the controller can be wirelessly accessed via the IEEE 802.15.4 protocol for performing TSII maintenance.

(Revision 2.0)

The Model Number TSII-CONTRL3 is the same as Model Number TSII-CONTRL2 except the Delay Board is removed from the Controller Board.

Information about the 2.4 GHz radio is presented below:

<b>Applicant</b>	S&C Electric Company
<b>Model No.</b>	TSII-CONTRL2 & TSII-CONTRL3
<b>FCC Identifier</b>	U3D-TSIICONTRL2
<b>Type of transmission</b>	Digital Transmission System (DTS)
<b>Rated RF Output</b>	8.23 dBm or 6.653mW
<b>Antenna(s) &amp; Gain</b>	Internal PCB Antenna, Gain: -5 dBi
<b>Frequency Range</b>	2405 – 2480 MHz
<b>Type of modulation/data rate</b>	O-QPSK / <200kbps
<b>Number of Channel(s)</b>	16 (from 11 to 26)
<b>Applicant Name &amp; Address</b>	S&C Electric Company 6601 N Ridge Blvd Chicago, IL 60626 USA

## 2.2 Related Submittal(s) Grants

None.

## 2.3 Test Facility

The test site used to collect the radiated data is site 1 (10-m semi-anechoic chamber). This test facility and site measurement data have been fully placed on file with the FCC, IC and A2LA accredited.

## 2.4 Test Methodology

Antenna conducted measurements were performed according to the FCC documents “Guidance for Performing Compliance Measurement on Digital Transmission Systems (DTS) Operating under §15.247” (KDB 558074 D01 DTS Meas Guidance v03r05 April 8, 2016), and RSS-247, RSS-GEN.

Radiated emissions and AC mains conducted emissions measurements were performed according to the procedures in ANSI C63.10-2013 & ANSI C63.4-2014. Radiated tests were performed at an antenna to EUT distance of 3 meters, unless stated otherwise in the "Data Sheet" of this report.

## 2.5 Measurement Uncertainty

Compliance with the limits was based on the results of the measurements and doesn't take into account the measurement uncertainty.

### Estimated Measurement Uncertainty

Measurement	Expanded Uncertainty (k=2)		
	0.15 MHz – 1 GHz	1 GHz – 2.5 GHz	> 2.5 GHz
RF Power and Power Density – antenna conducted	-	0.7 dB	-
Unwanted emissions - antenna conducted	1.1 dB	1.3 dB	1.9 dB
Bandwidth – antenna conducted	-	30 Hz	-
Radiated emissions	4.2 dB	3.4 dB	4.4 dB
AC mains conducted emissions	2.4 dB	-	-

### 3.0 System Test Configuration

#### 3.1 Support Equipment

Item #	Description	Model No./ Part No.	Serial No.
1	Dell Laptop	Vostro 1440	33602643757
2	CUI AC/DC Power Adapter	EMSA120050	Not Labeled
3	USB Dongle	MC1322x	01.01.0D.A5

#### 3.2 Block Diagram of Test Setup

Antenna was removed and co-axial connector with a cable was installed for Conducted Measurements.  
Radiated Measurements were made with antenna in place.

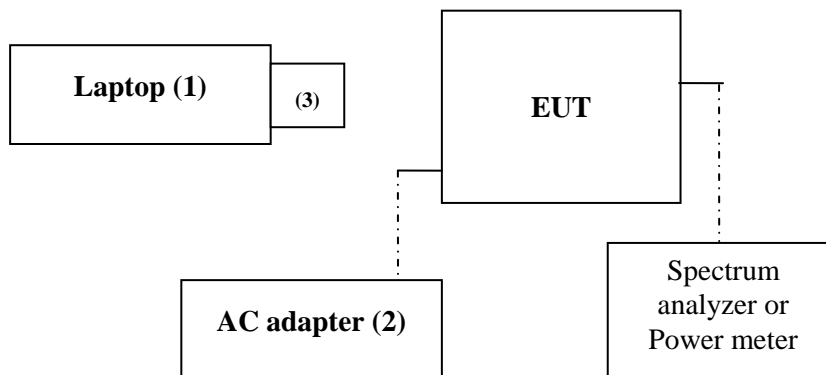

<b>S</b> = Shielded	<b>F</b> = With Ferrite
<b>U</b> = Unshielded	<b>m</b> = Length in Meters



### 3.3 Justification

For radiated emission measurements the EUT is placed on a non-conductive table.

#### Revision 2.0:

The difference between Model Number TSII-CONTRL2 and Model Number TSII-CONTRL3 is that Model Number TSII-CONTRL3 has the Delay Board removed from the Controller Board. Because the radio is not affected between the difference, only Radiated Emissions and Conducted Emissions were re-tested (see Appendix A for test results).

### 3.4 Software Exercise Program

The EUT exercise program used during radiated and conducted testing was provided by S&C Electric Company

### 3.5 Mode of Operation during Test

During transmitter testing, the transmitter was setup to transmit at maximum RF power on low, middle and high frequencies/channels. Their corresponding output power in dBm can be found in section 4.2 of this report.

Frequency (MHz)	Channel	Software Power Setting
2405	11	28
2440	18	28
2480	26	28

### 3.5 Modifications Required for Compliance

Intertek installed no modifications during compliance testing in order to bring the product into compliance.

### 3.6 Additions, Deviations and Exclusions from Standards

No additions, deviations or exclusions from the standard were made.

#### 4.0 Measurement Results

4.1 6-dB Bandwidth and Occupied Bandwidth  
 FCC Rule: 15.247(a)(2); RSS-247 A8.2 and RSS-GEN;

##### 4.1.1 Requirement

The minimum 6-dB bandwidth shall be at least 500 kHz

##### 4.1.2 Procedure

A spectrum analyzer was connected to the antenna port of the transmitter.

For FCC 6dB Channel Bandwidth the Procedure described in the FCC Publication 558074 D01 DTS Meas Guidance v03r05 April 8, 2016 was used to determine the DTS occupied bandwidth. Section 8.1 Option 1 was used.

1. Set RBW = 100 kHz.
2. Set the video bandwidth (VBW)  $\geq 3 \times$  RBW.
3. Detector = Peak.
4. Trace mode = max hold.
5. Sweep = auto couple.
6. Allow the trace to stabilize.
7. Measure the maximum width of the emission that is constrained by the frequencies associated with the two outermost amplitude points (upper and lower frequencies) that are attenuated by 6 dB relative to the maximum level measured in the fundamental emission.

For 99% power bandwidth measurement, the bandwidth was determined by using the built-in 99% occupied bandwidth function of the spectrum analyzer. The resolution bandwidth is set to 1% of the selected span as is without being below 1%. The video bandwidth shall be set to 3 times the resolution bandwidth.

##### 4.1.3 Test Result

Frequency (MHz)	6-dB bandwidth FCC 15.247 & RSS-GEN, MHz	Occupied bandwidth, RSS-GEN, MHz	Plot
2405	1.55	--	1.1
	--	2.31	1.4
2440	1.54	--	1.2
	--	2.32	1.5
2480	1.55	--	1.3
	--	2.36	1.6

<b>Date of Test:</b>	July 29, 2016
<b>Results</b>	<b>Complies</b>

Plot 1. 1

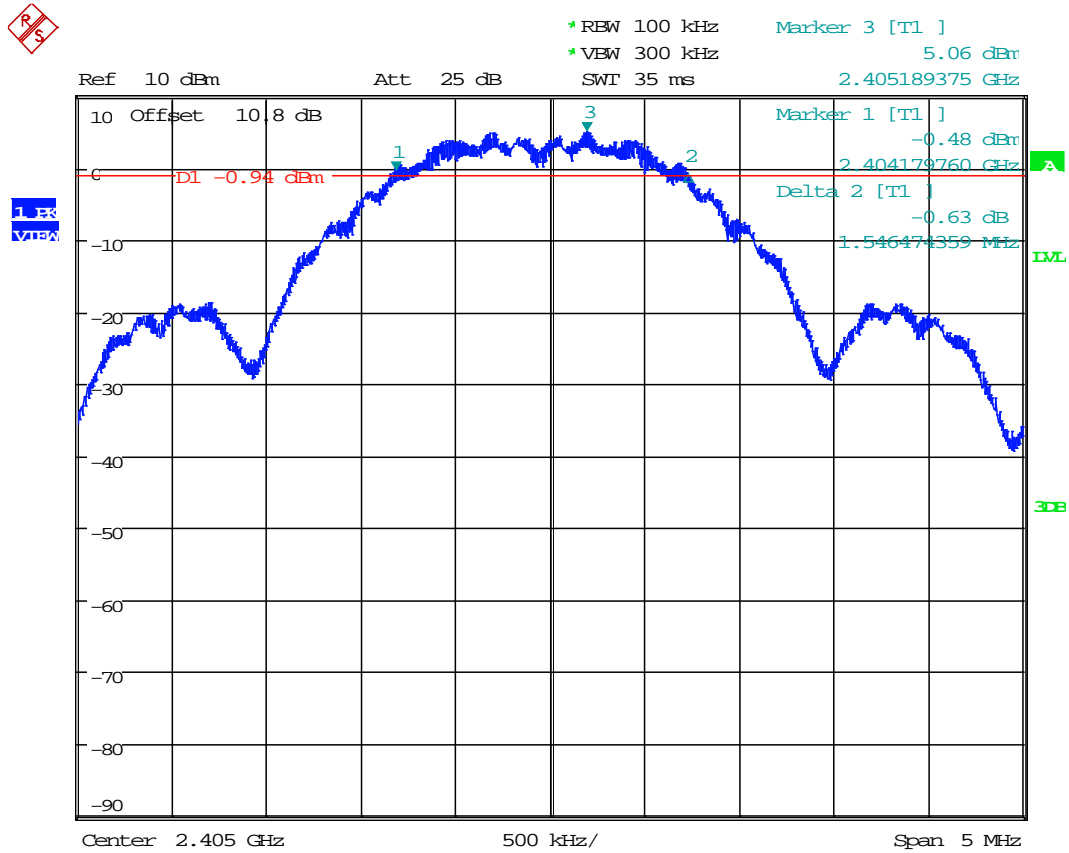

Date: 29.JUL.2016 09:47:46

Plot 1.2

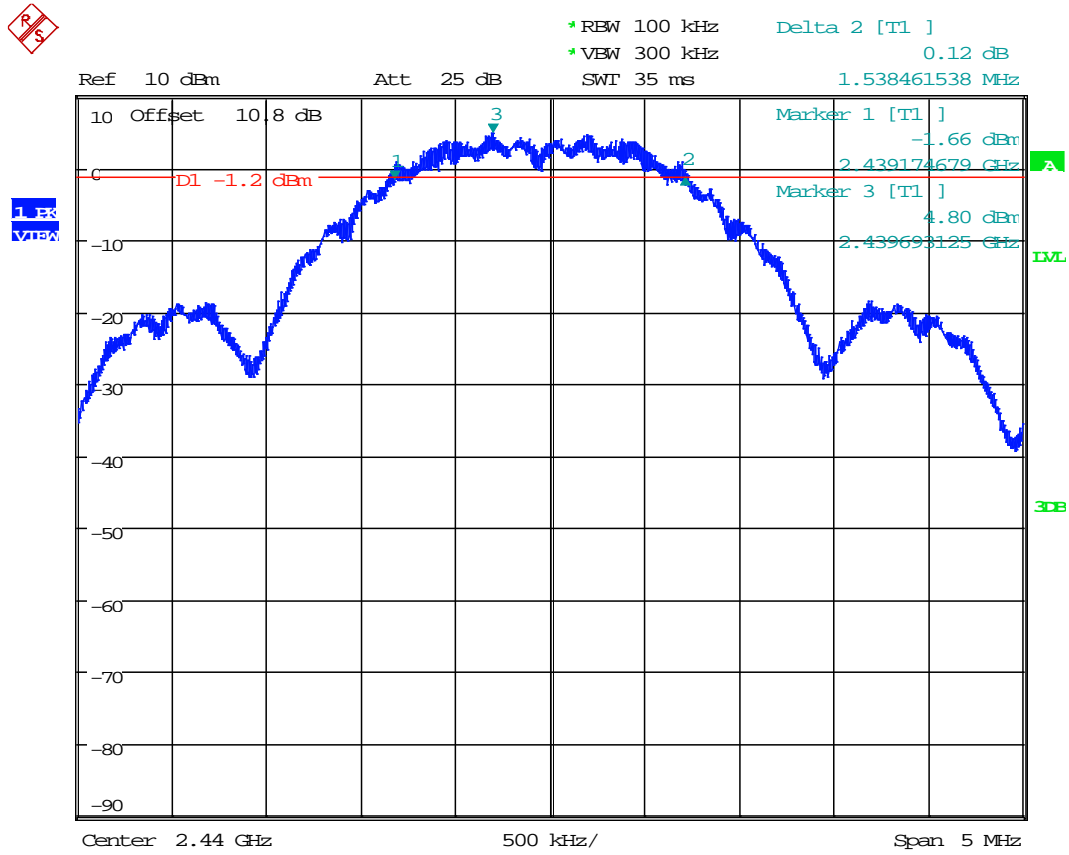

Date: 29.JUL.2016 10:24:04

Plot 1.3

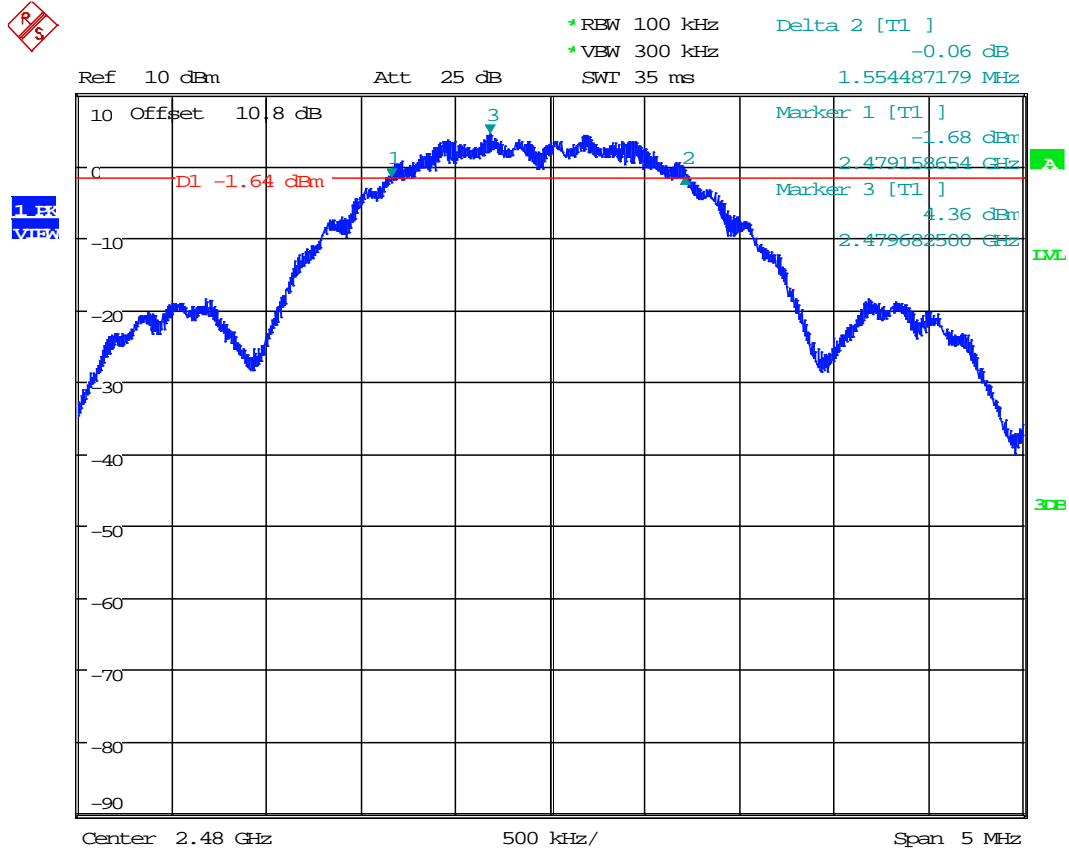

Date: 29.JUL.2016 10:25:45

Plot 1.4

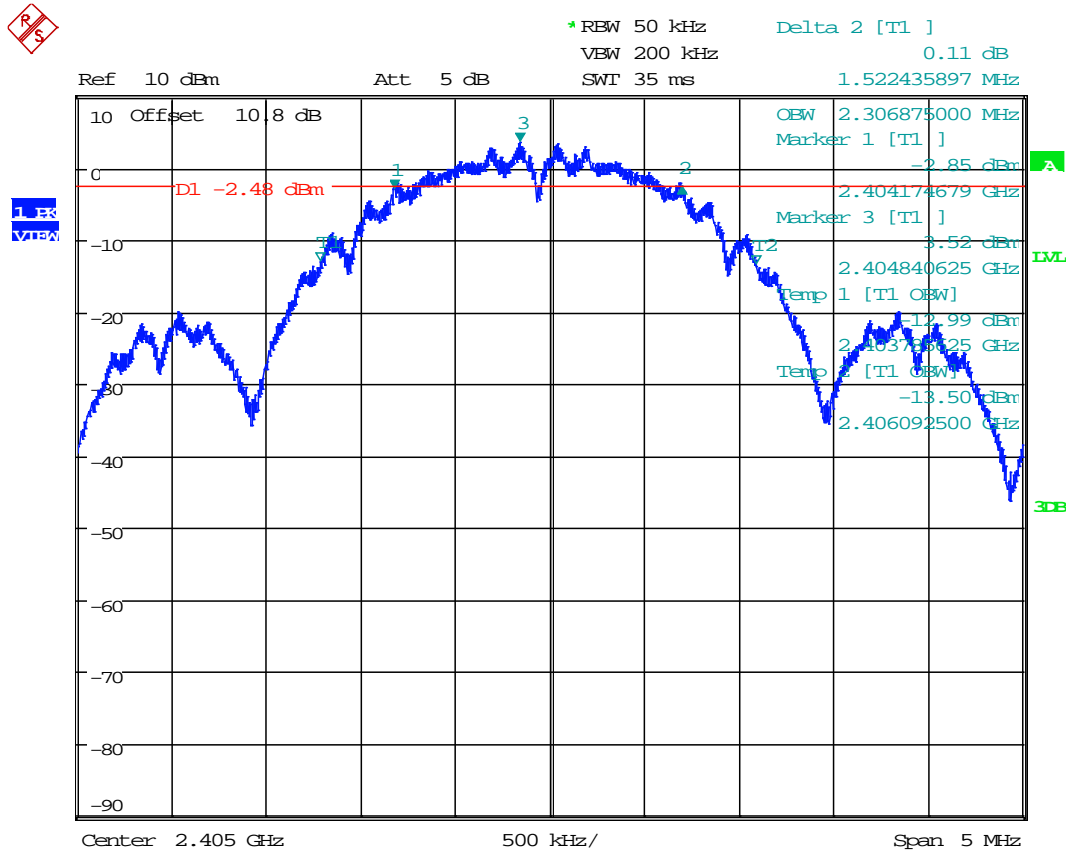

Date: 29.JUL.2016 10:44:16

Plot 1.5

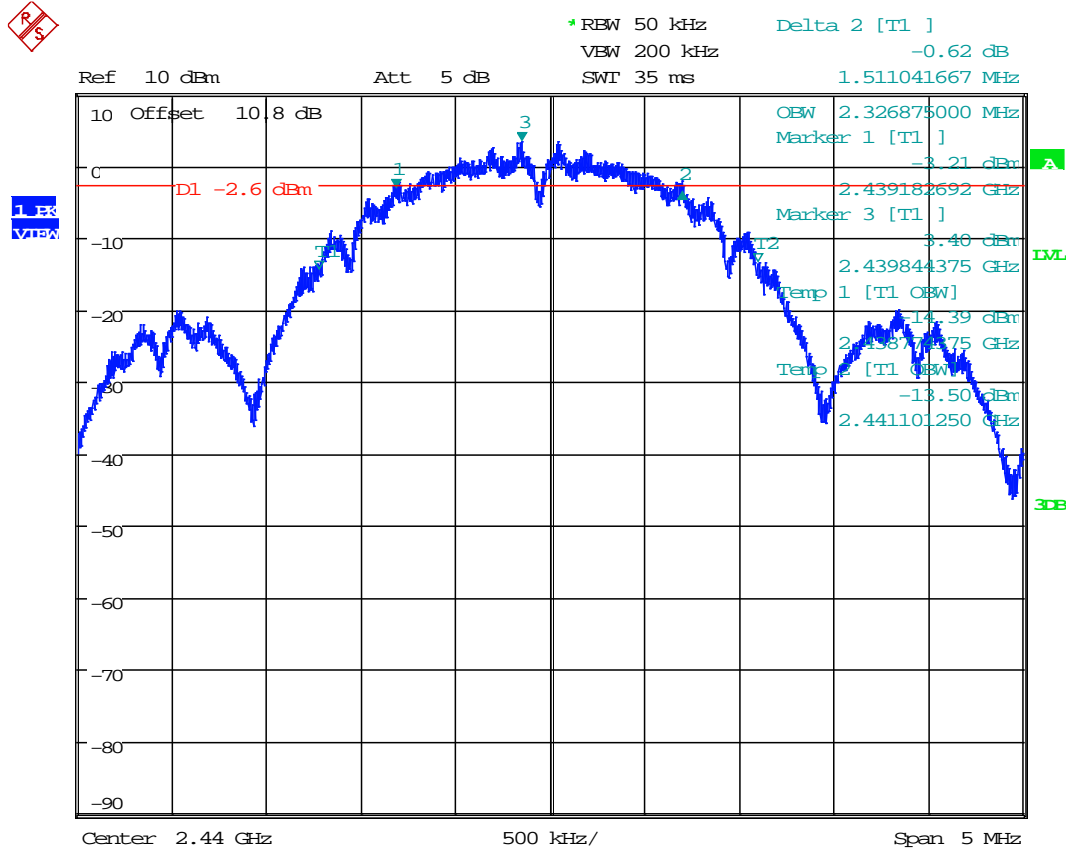

Date: 29.JUL.2016 10:31:03

Plot 1.6

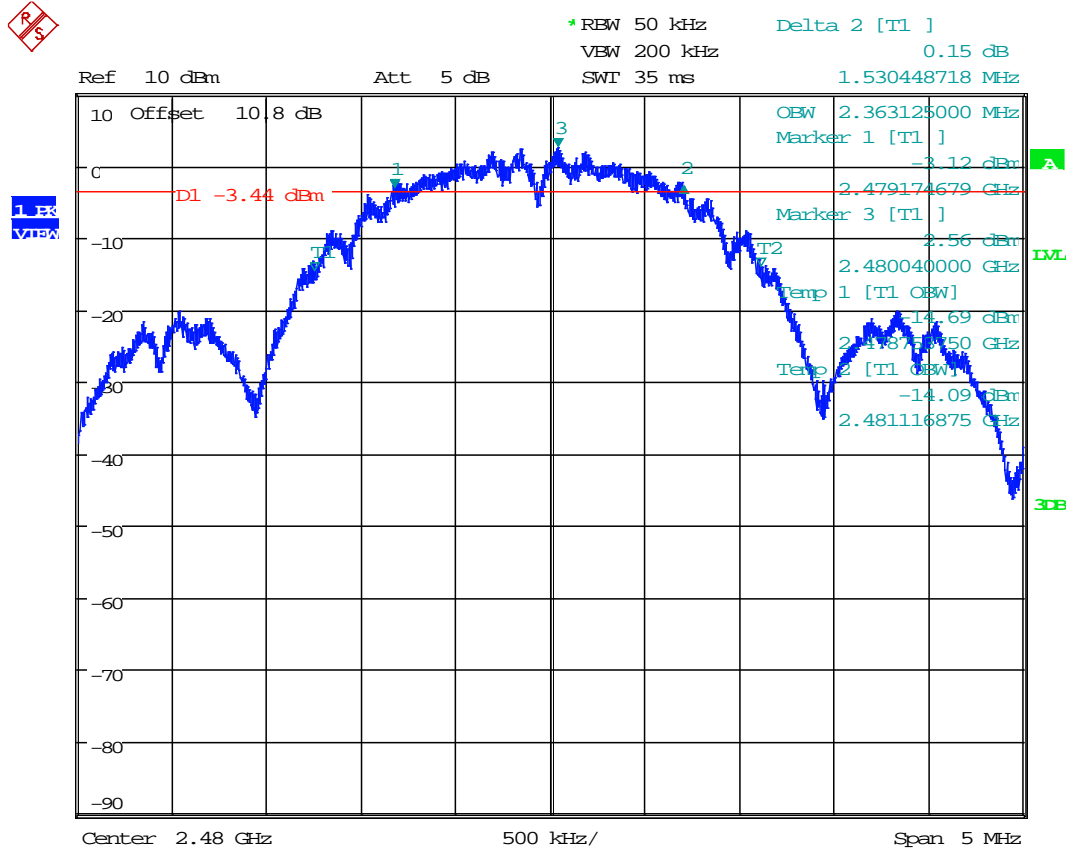

Date: 29.JUL.2016 10:28:29



4.2 Maximum Peak Conducted Output Power at Antenna Terminals  
 FCC Rule: 15.247(b)(3); RSS-247 A8.4;

4.2.1 Requirement

For antennas with gains of 6 dBi or less, maximum allowed transmitter output is 1 watt or 30 dBm. For antennas with gains greater than 6 dBi, transmitter output level must be decreased appropriately, by the amount in dB that the directional gain of the antenna exceeds 6 dBi.

4.2.2 Procedure

The procedure described in FCC Publication 558074 D01 DTS Meas Guidance v03r05 April 8, 2016 was used. Specifically, section 9.1.1 RBW ≥ DTS Bandwidth was utilized as the spectrum analyzer’s resolution bandwidth was greater than the DTS bandwidth.

1. Set the RBW ≥ DTS Bandwidth
2. Set the VBW ≥ 3 x RBW
3. Set the span ≥ 3 x RBW
4. Detector = Peak
5. Sweep time = Auto couple
6. Trace mode = Max Hold
7. Allow trace to fully stabilize
8. Use peak marker function to determine the peak amplitude level.

A spectrum analyzer was connected to the antenna port of the transmitter.

4.3.3 Test Result

Refer to the following plots 2.1 – 2.3 for the test details.

Frequency, MHz	Conducted Power (peak), dBm	Conducted Power (peak), mW	Plot
2405	8.23	6.653	2.1
2440	7.93	6.209	2.2
2480	7.71	5.902	2.3

<b>Date of Test:</b>	July 25, 2016
<b>Results</b>	<b>Complies</b>

Plot 2. 1

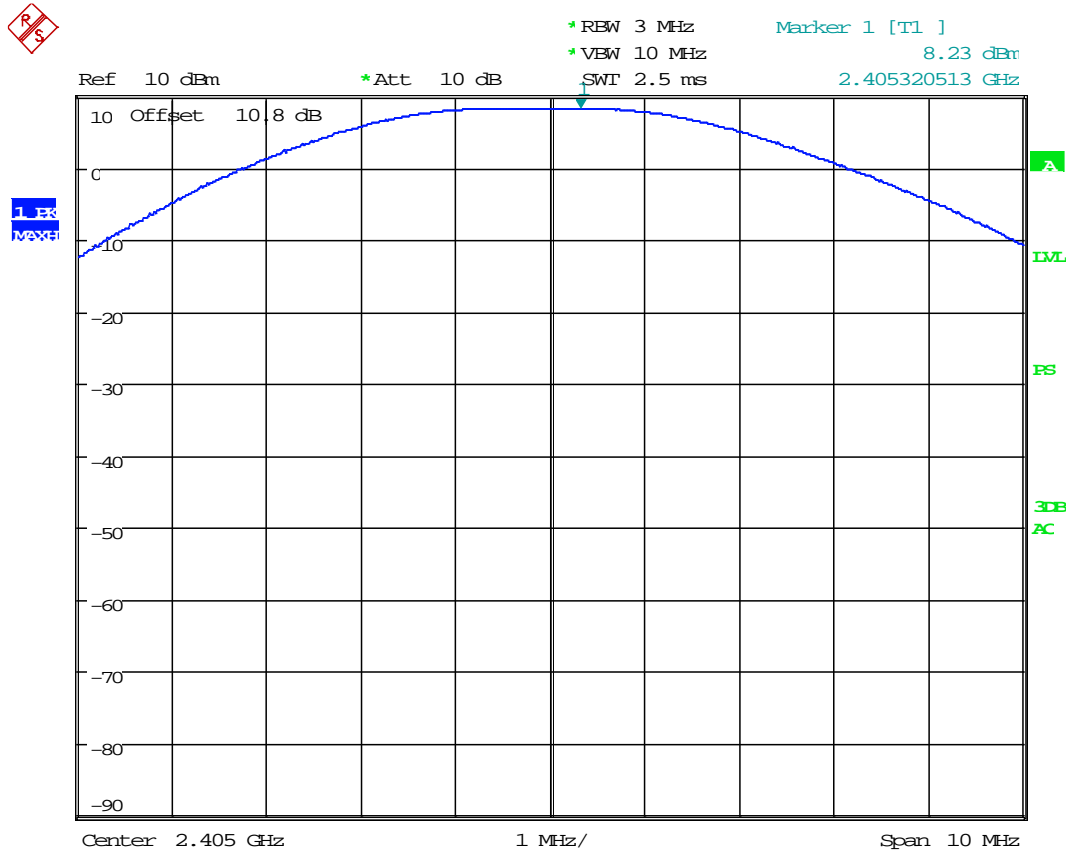

Date: 25.JUL.2016 12:50:55





4.3 Maximum Power Spectral Density  
FCC: 15.247 (e); RSS-247 A8.2b;

4.3.1 Requirement

For digitally modulated systems, the power spectral density conducted from the intentional radiator to the antenna should not be greater than 8 dBm in any 3 kHz band during any time interval of continuous transmission.

4.3.2 Procedure

A spectrum analyzer was connected to the antenna port of the transmitter.

The procedure described in FCC Publication 558074 D01 DTS Meas Guidance v03r05 April 8, 2016, specifically section 10.2 Method PKPSD (peak PSD).

1. Set analyzer center frequency to DTS channel center frequency.
2. Set the span to 1.5 times the *DTS bandwidth*.
3. Set the RBW to:  $3 \text{ kHz} \leq \text{RBW} \leq 100 \text{ kHz}$ .
4. Set the VBW  $\geq 3 \times \text{RBW}$ .
5. Detector = peak.
6. Sweep time = auto couple.
7. Trace mode = max hold.
8. Allow trace to fully stabilize.
9. Use the peak marker function to determine the maximum amplitude level within the RBW.
10. If measured value exceeds limit, reduce RBW (no less than 3 kHz) and repeat.

4.3.3 Test Result

Refer to the following plots for the test result

Frequency, MHz	Maximum Power Spectral Density, dBm	Maximum Power Spectral Density Limit, dBm	Margin, dB	Plot
2405	1.61	8.0	-6.39	3.1
2440	1.60	8.0	-6.40	3.2
2480	0.89	8.0	-7.11	3.3

<b>Date of Test:</b>	July 29, 2016
<b>Results</b>	<b>Complies</b>

Plot 3. 1

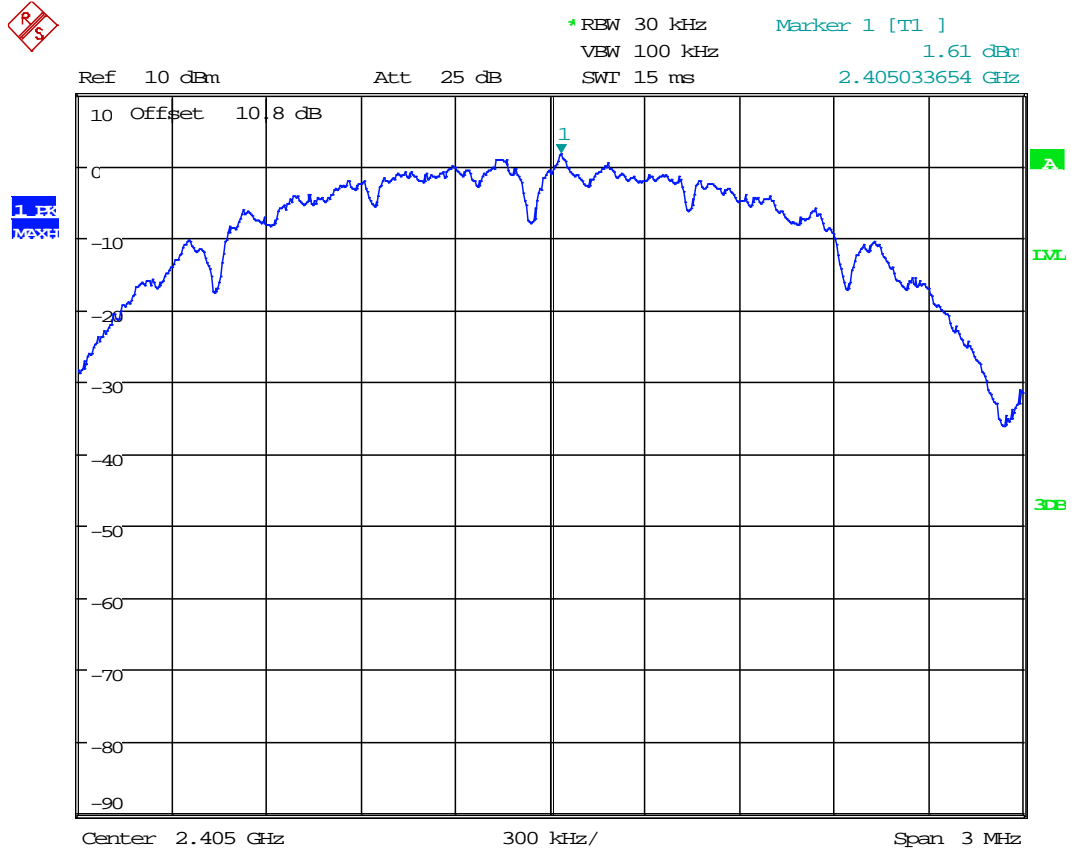

Date: 29.JUL.2016 08:24:07

Plot 3.2

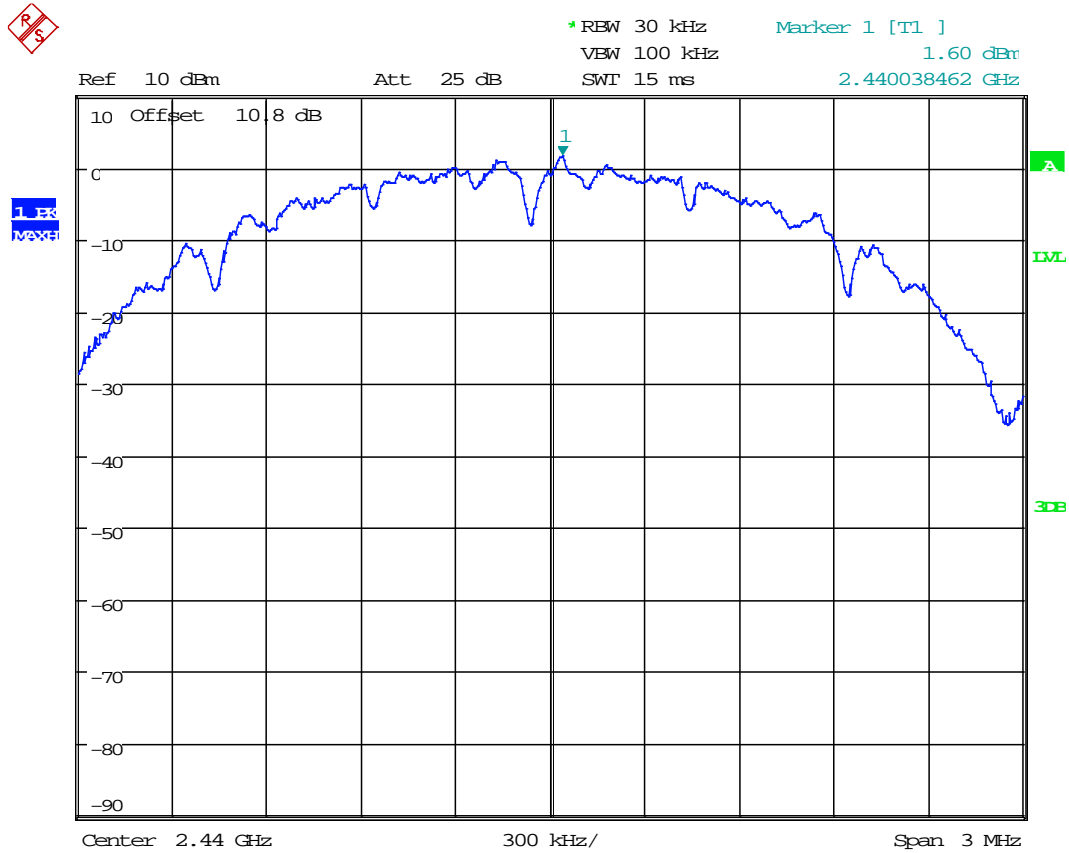

Date: 29.JUL.2016 08:23:16

Plot 3.3

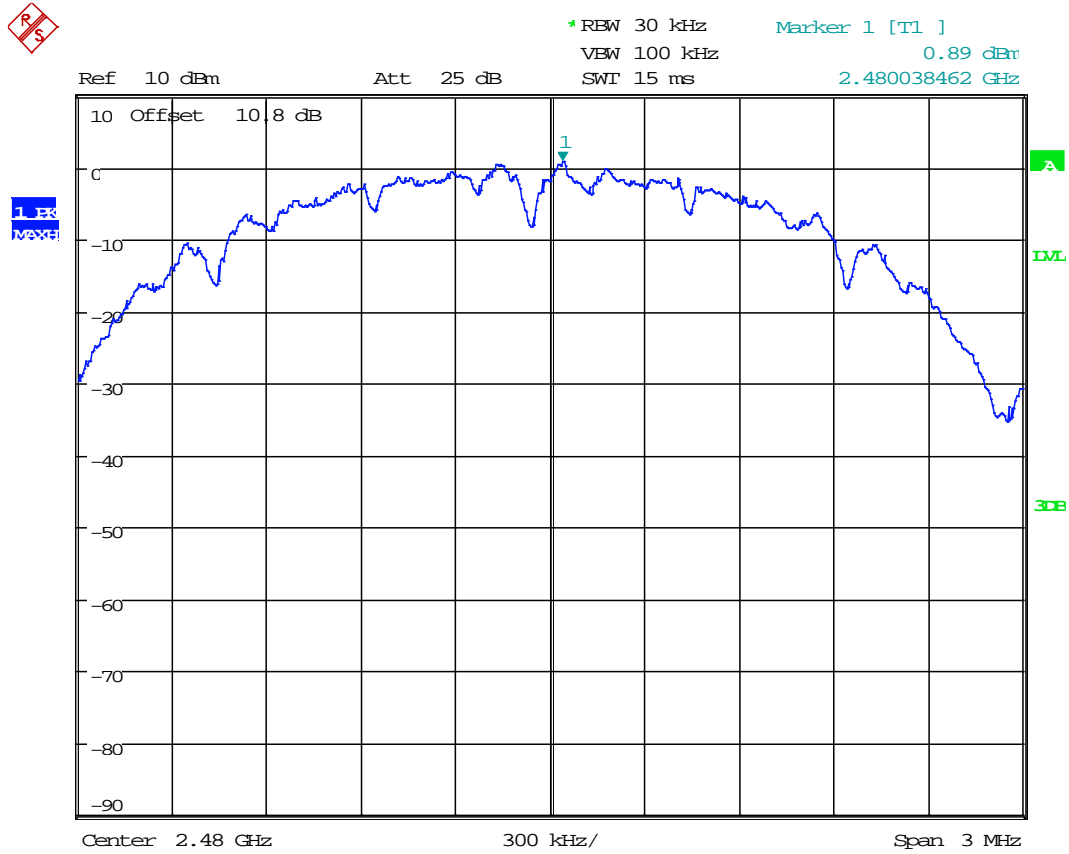

Date: 29.JUL.2016 08:21:56



4.4 Unwanted Conducted Emissions  
FCC: 15.247(d); RSS-247 A8.5;

4.4.1 Requirement

In any 100 kHz bandwidth outside the EUT pass-band, the RF power shall be below the maximum in-band 100 kHz emissions by at least 20 dB (if peak power of in-band emission is measured) or 30 dB (if average power of in-band emission is measured).

In addition, radiated emissions which fall in the restricted bands, as defined in § 15.205(a), must also comply with the radiated emission limits specified in § 15.209(a)

4.4.2 Procedure

The procedure described in FCC Publication 558074 D01 DTS Meas Guidance v03r05 April 8, 2016, specifically section 11.0 Emissions in non-restricted frequency bands.

A spectrum analyzer was connected to the antenna port of the transmitter.

1. Set the RBW = 100 kHz.
2. Set the VBW  $\geq 3 \times$  RBW.
3. Detector = peak.
4. Sweep time = auto couple.
5. Trace mode = max hold.
6. Allow trace to fully stabilize.
7. Use the peak marker function to determine the maximum amplitude level.

The unwanted emissions were measured from 30 MHz to 25 GHz. Plots below are corrected for cable loss and then compared to the limits.

4.4.3 Test Result

Refer to the following plots 4.1 – 4.5 for unwanted conducted emissions. The plot shows -20dB attenuation limit line.

<b>Date of Test:</b>	July 29, 2016
<b>Results</b>	<b>Complies</b>

Tx @ Low Channel, 2400 MHz Band Edge  
Plot 4.1

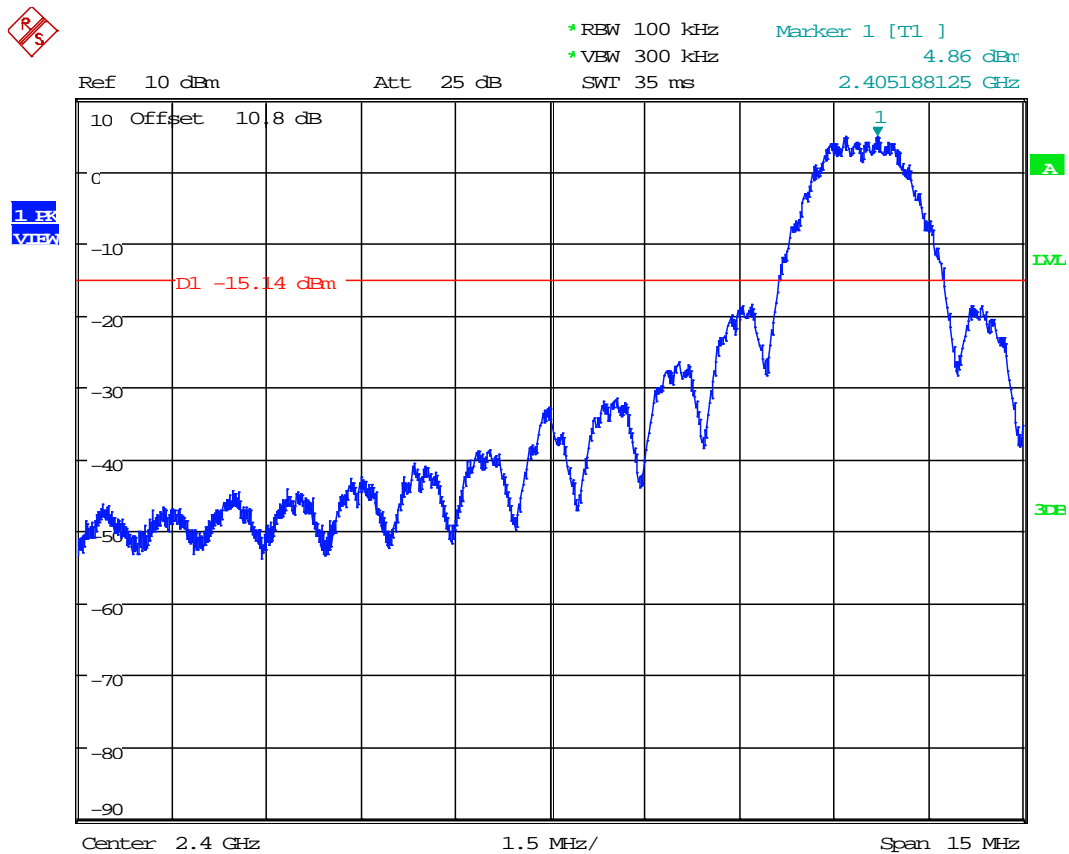

Date: 29.JUL.2016 09:38:56

Tx @ Low Channel, 2483.5 MHz Band Edge  
Plot 4.2

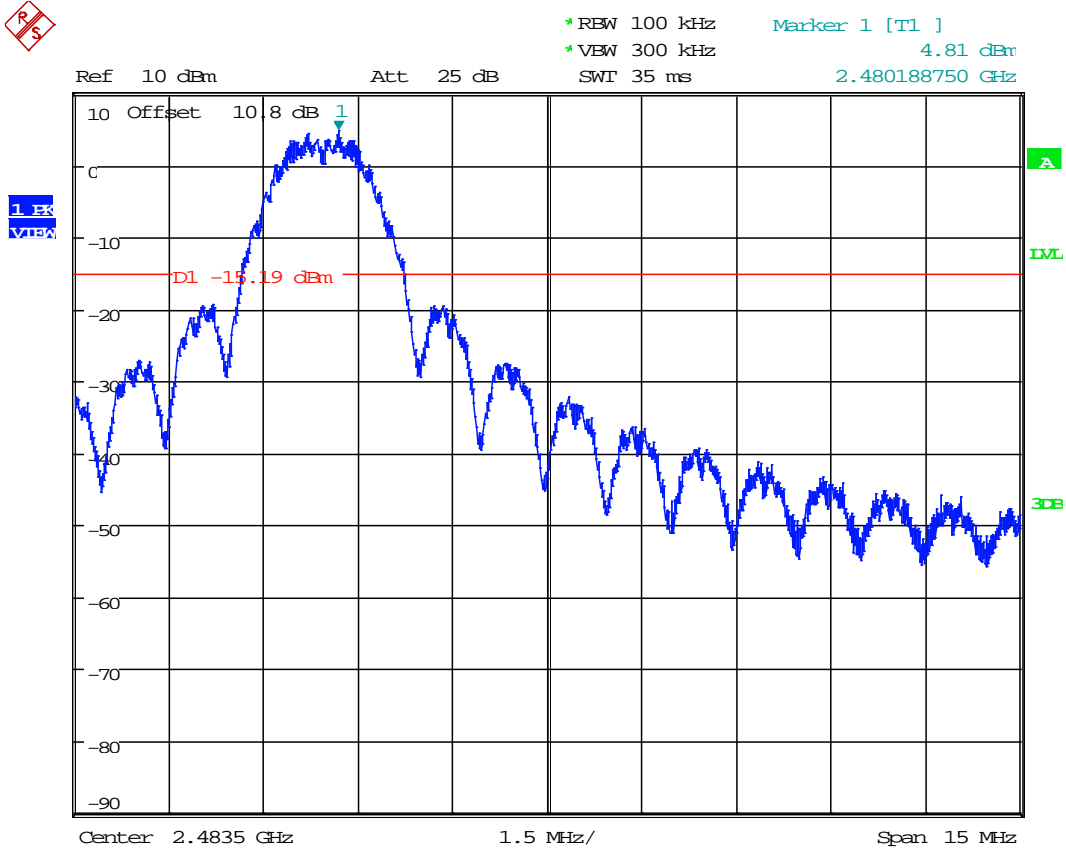

Date: 29.JUL.2016 09:24:41

Tx @ Low Channel, 2405 MHz  
30MHz -26GHz Conducted Spurious  
Plot 4.3

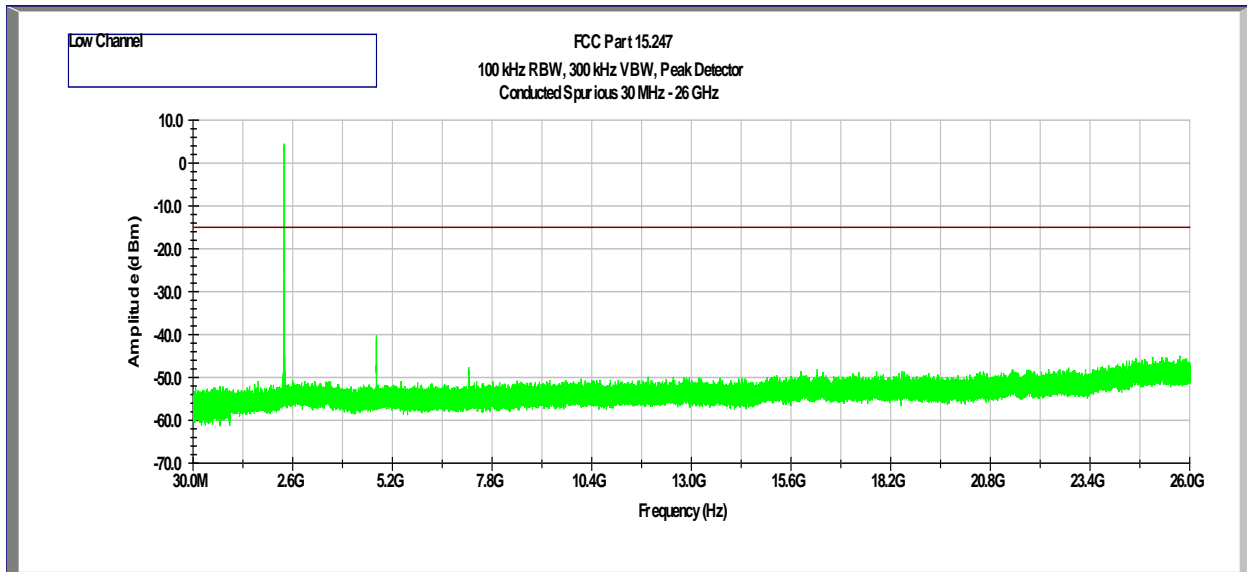

Tx @ Mid Channel, 2440 MHz  
30MHz -26GHz Conducted Spurious  
Plot 4.5

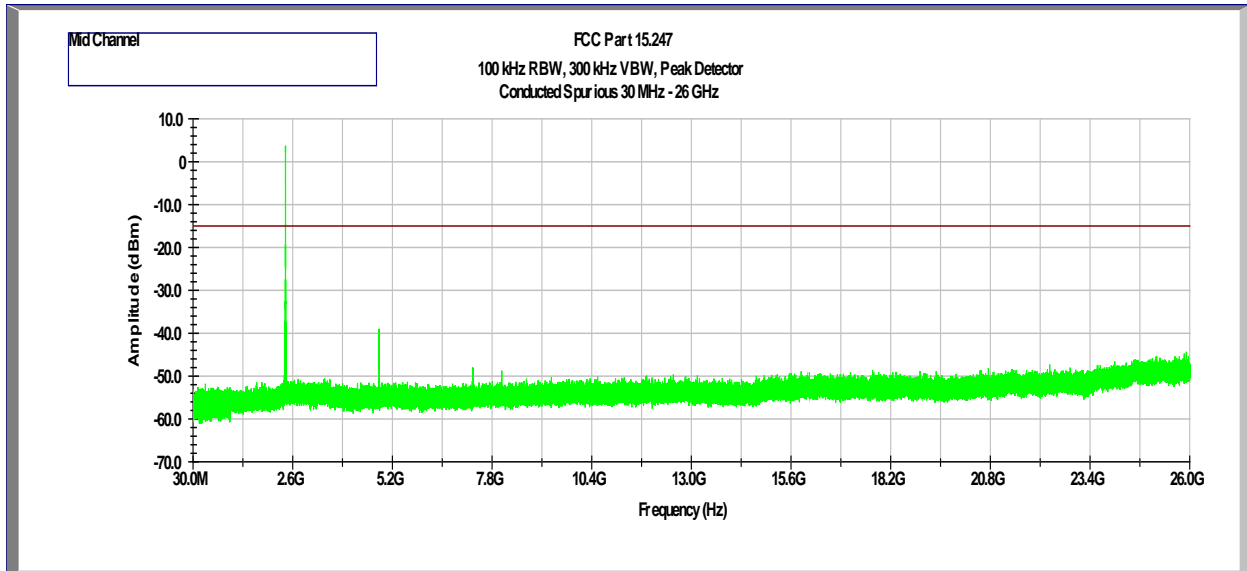

Tx @ High Channel, 2480 MHz  
30MHz -26GHz Conducted Spurious  
Plot 4.5

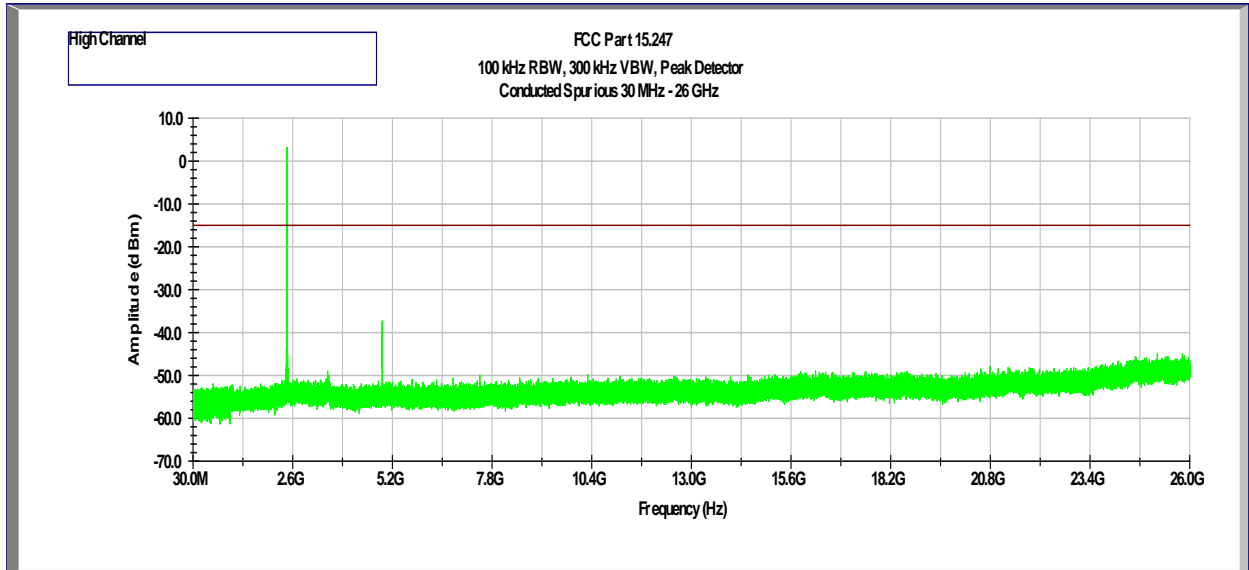

#### 4.5 Transmitter Radiated Emissions FCC Rules: 15.247(d), 15.209, 15.205; RSS-247;

##### 4.5.1 Requirement

Radiated emissions which fall in the restricted bands, as defined in §15.205(a), must also comply with the radiated emission limits specified in §15.209(a) (see §15.205(c)).

For out of band radiated emissions (except for frequencies in restricted bands), in any 100 kHz bandwidths outside the EUT pass-band, the RF power shall be at least 20dB (peak) or 30 dB (average) below that of the maximum in-band 100 kHz emissions.

##### 4.5.2 Procedure

Radiated emission measurements were performed from 30 MHz to 25 GHz according to the procedure described in ANSI C63.10. Spectrum Analyzer Resolution Bandwidth is 100 kHz or greater for frequencies 30 MHz to 1000 MHz, 1 MHz for frequencies above 1000 MHz. Above 1000 MHz Peak and Average measurements were performed.

The EUT is placed on a plastic turntable that is 80 cm in height for below 1000MHz and 1.5m in height for above 1GHz. If the EUT attaches to peripherals, they are connected and operational (as typical as possible). During testing, all cables were manipulated to produce worst-case emissions. The signal is maximized through rotation. The antenna height and polarization are varied during the search for maximum signal level. The antenna height is varied from 1 to 4 meters.

Radiated emissions are taken at 3 meters for frequencies above 1 GHz and at 10 meters for frequencies below 1 GHz.

Measurements made from 1 GHz to 18GHz had a 2.4-2.5GHz notch filter in place. A preamp was used from 30MHz to 25GHz.

All measurements were made with a Peak Detector and compared to QP limits for 30MHz – 1GHz and Average limits for 1GHz – 25GHz.

Data is included of the worst-case configuration (the configuration which resulted in the highest emission levels).

### 4.5.3 Field Strength Calculation

#### Field Strength Calculation

The field strength is calculated by adding the Antenna Factor and Cable Factor, and subtracting the Amplifier Gain (if any) from the measured reading. The basic equation with a sample calculation is as follows:

$FS = RA + AF + CF - AG$ ; if measurement is performed at a distance other than specified in the rule, a Distance Correction Factor (DCF) shall be added.

Where  $FS$  = Field Strength in  $dB(\mu V/m)$

$RA$  = Receiver Amplitude (including preamplifier) in  $dB(\mu V)$ ;  $AF$  = Antenna Factor in  $dB(1/m)$

$CF$  = Cable Attenuation Factor in  $dB$ ;  $AG$  = Amplifier Gain in  $dB$

Assume a receiver reading of  $52.0\text{ dB}(\mu V)$  is obtained. The antennas factor of  $7.4\text{ dB}(1/m)$  and cable factor of  $1.6\text{ dB}$  is added. The amplifier gain of  $29\text{ dB}$  is subtracted, giving field strength of  $32\text{ dB}(\mu V/m)$ . This value in  $dB(\mu V/m)$  was converted to its corresponding level in  $\mu V/m$ .

$RA = 52.0\text{ dB}(\mu V)$

$AF = 7.4\text{ dB}(1/m)$

$CF = 1.6\text{ dB}$

$AG = 29.0\text{ dB}$

$FS = 52.0 + 7.4 + 1.6 - 29.0 = 32\text{ dB}(\mu V/m)$ .

Level in  $\mu V/m = \text{Common Antilogarithm} [(32\text{ dB}\mu V/m)/20] = 39.8\text{ }\mu V/m$ .



#### 4.5.4 Antenna-port conducted measurements

Antenna-port conducted measurements may also be used as an alternative to radiated measurements for demonstrating compliance in the restricted frequency bands. If conducted measurements are performed, then proper impedance matching must be ensured and an additional radiated test for cabinet/case spurious emissions is required.

#### 4.5.6 General Procedure for conducted measurements in restricted bands

a) Measure the conducted output power (in dBm) using the detector specified for determining quasi-peak, peak, and average conducted output power, respectively.

b) Add the maximum transmit antenna gain (in dBi) to the measured output power level to determine the EIRP level (see 12.2.5 for guidance on determining the applicable antenna gain)

c) Add the appropriate maximum ground reflection factor to the EIRP level (6 dB for frequencies  $\leq 30$  MHz, 4.7 dB for frequencies between 30 MHz and 1000 MHz, inclusive and 0 dB for frequencies  $> 1000$  MHz).

d) For devices with multiple antenna-ports, measure the power of each individual chain and sum the EIRP of all chains in linear terms (*e.g.*, Watts, mW).

e) Convert the resultant EIRP level to an equivalent electric field strength using the following relationship:

$$E = \text{EIRP} - 20\log D + 104.8$$

where:

E = electric field strength in dB $\mu$ V/m,

EIRP = equivalent isotropic radiated power in dBm

D = specified measurement distance in meters.

f) Compare the resultant electric field strength level to the applicable limit.

g) Perform radiated spurious emission test

#### 4.5.7 Test Results

The data on the following pages list the significant emission frequencies, the limit and the margin of compliance where emissions are within 3dB of the limit.

If conducted measurements were performed, all conducted antenna port plots are corrected with the consideration of the EUT's Antenna Gain (minimum 2 dBi).

Radiated emission measurements were performed up to 25GHz. No Emissions were identified when scanned from 18-25 GHz.

<b>Date of Test:</b>	May 20 & July 22, 2016
<b>Results</b>	<b>Complies</b>





**Test Results: 15.209/15.205 Restricted Band Emissions (Radiated Method)**

**Out-of-Band Spurious Emissions at the Band Edge – Tx @ 2405 MHz**

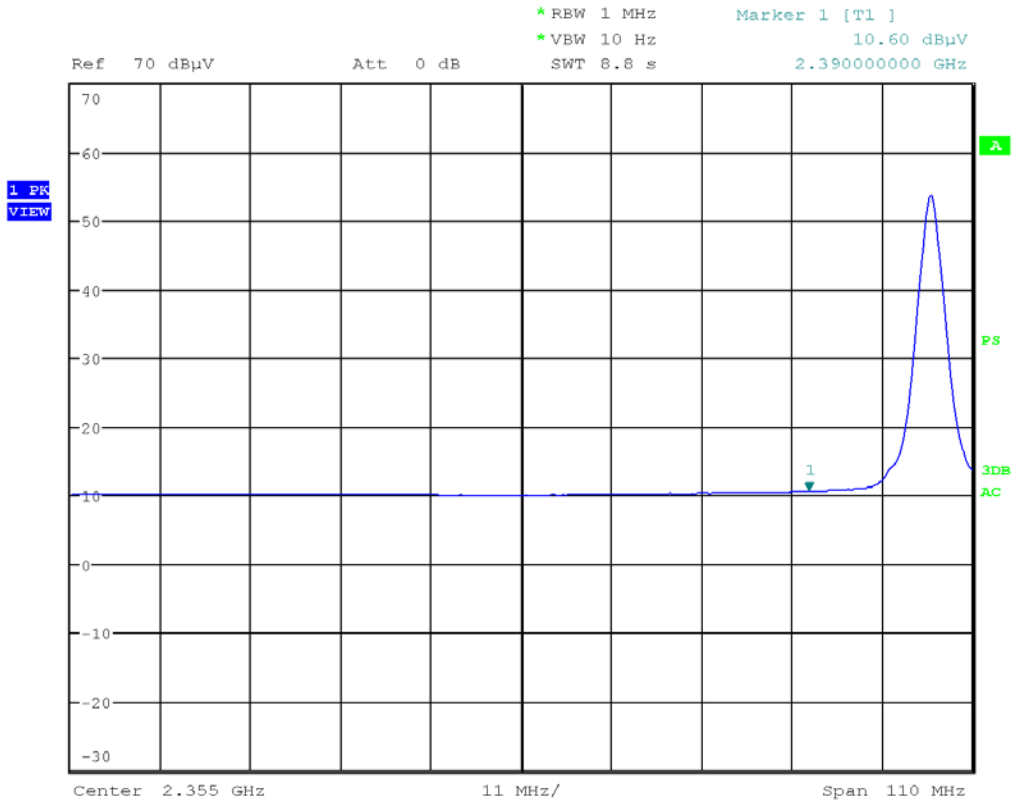

Date: 22.JUL.2016 08:11:42

Frequency	Raw Amplitude at 3m	Correction Factor	Corrected Amplitude	Peak Limit	Margin	Detector	Results
GHz	dBμV/m	dB	dBμV/m	dBμV/m	dB		
2.390	10.6	32.3	42.9	54	-11.1	Avg	Pass

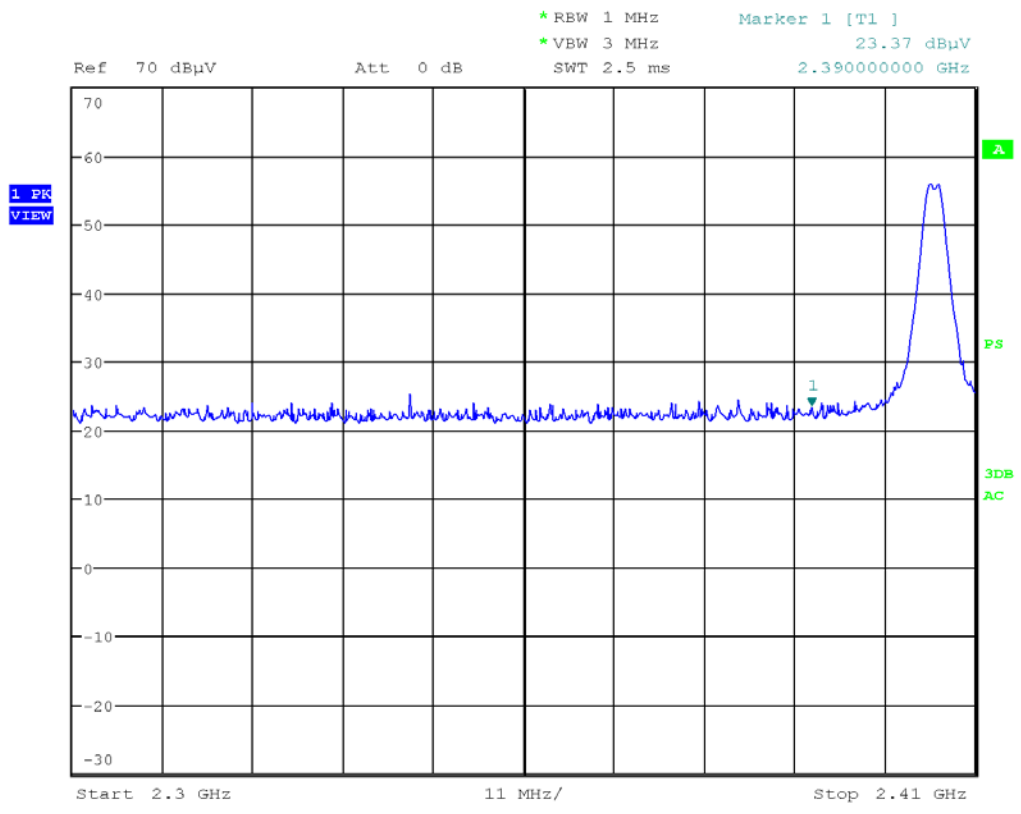

Date: 22.JUL.2016 08:10:59

Frequency	Raw Amplitude at 3m	Correction Factor	Corrected Amplitude	Peak Limit	Margin	Detector	Results
GHz	dBμV/m	dB	dBμV/m	dBμV/m	dB	Peak	Pass
2.390	23.4	32.3	55.7	74	-18.7	Peak	Pass



**Out-of-Band Spurious Emissions at the Band Edge – Tx @ 2480 MHz**

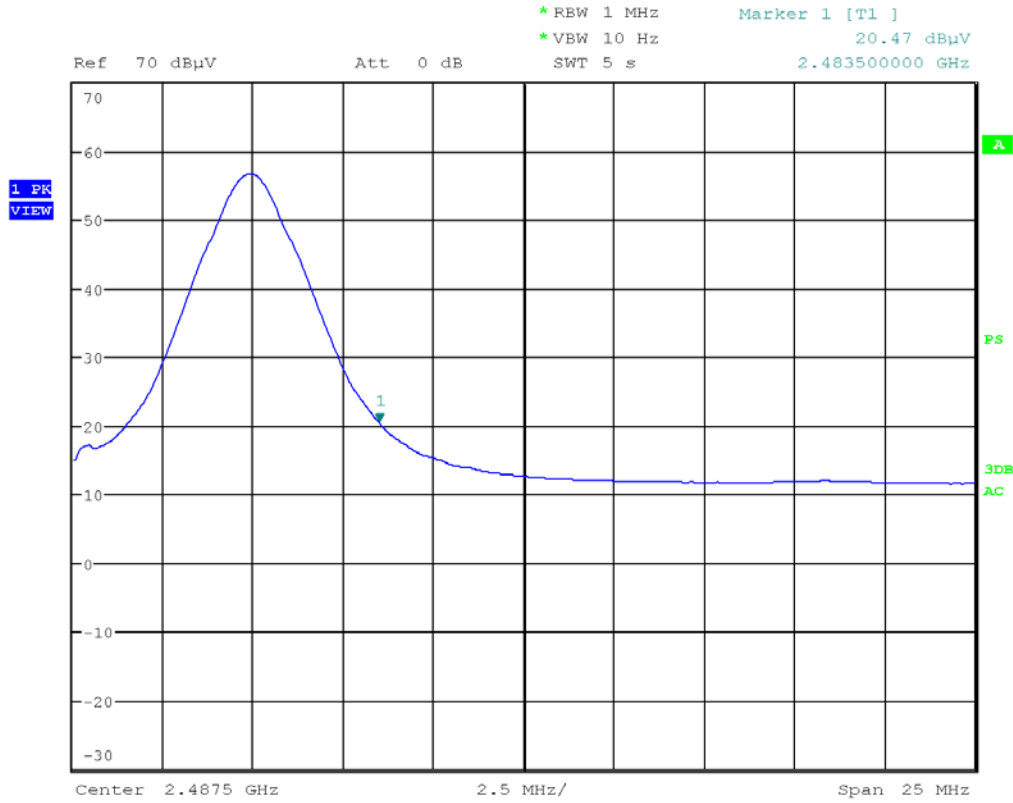

Date: 22.JUL.2016 07:55:57

Frequency	Raw Amplitude at 3m	Correction Factor	Corrected Amplitude	Peak Limit	Margin	Detector	Results
GHz	dBμV/m	dB	dBμV/m	dBμV/m	dB		
2.4835	20.5	32.3	52.8	54	-1.2	Avg	Pass

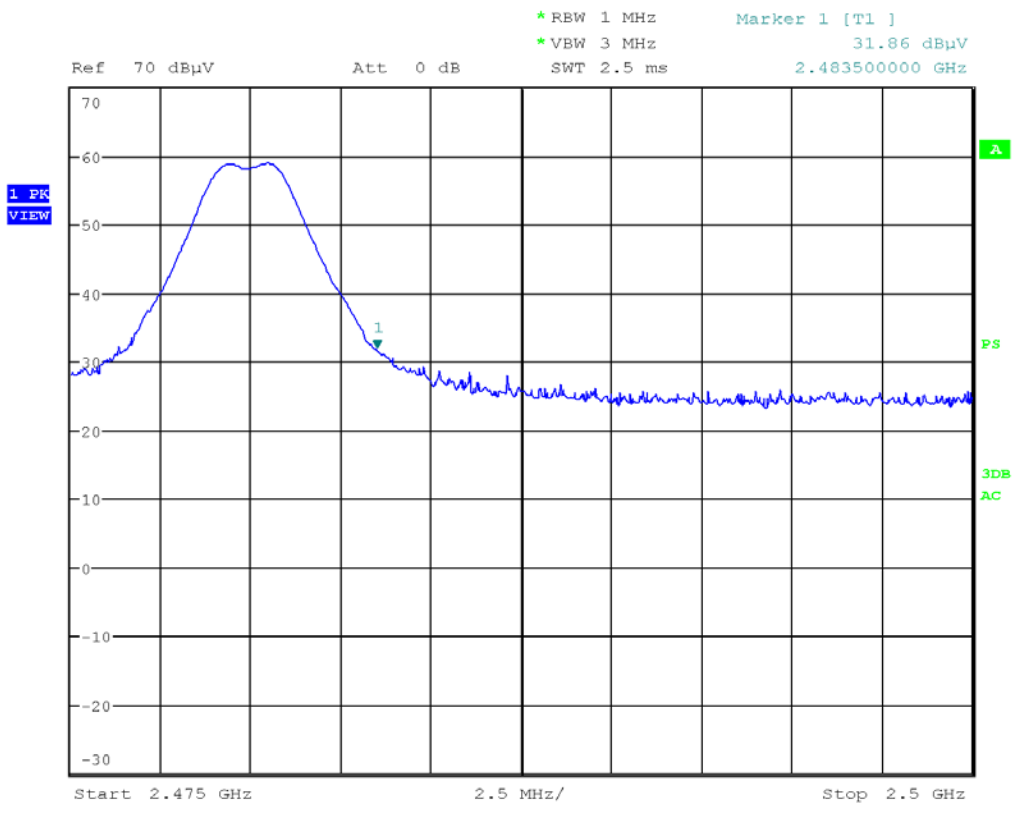

Date: 22.JUL.2016 07:54:46

Frequency	Raw Amplitude at 3m	Correction Factor	Corrected Amplitude	Peak Limit	Margin	Detector	Results
GHz	dBμV/m	dB	dBμV/m	dBμV/m	dB	Peak	Pass
2.4835	31.9	32.3	64.2	74	-9.8		

### Out-of-Band Radiated Spurious Emissions (Radiated Method)

Test Results: 15.209 Radiated Spurious Emissions Low Channel, Tx at 2405MHz

Radiated Spurious Emissions 30 MHz - 1000 MHz

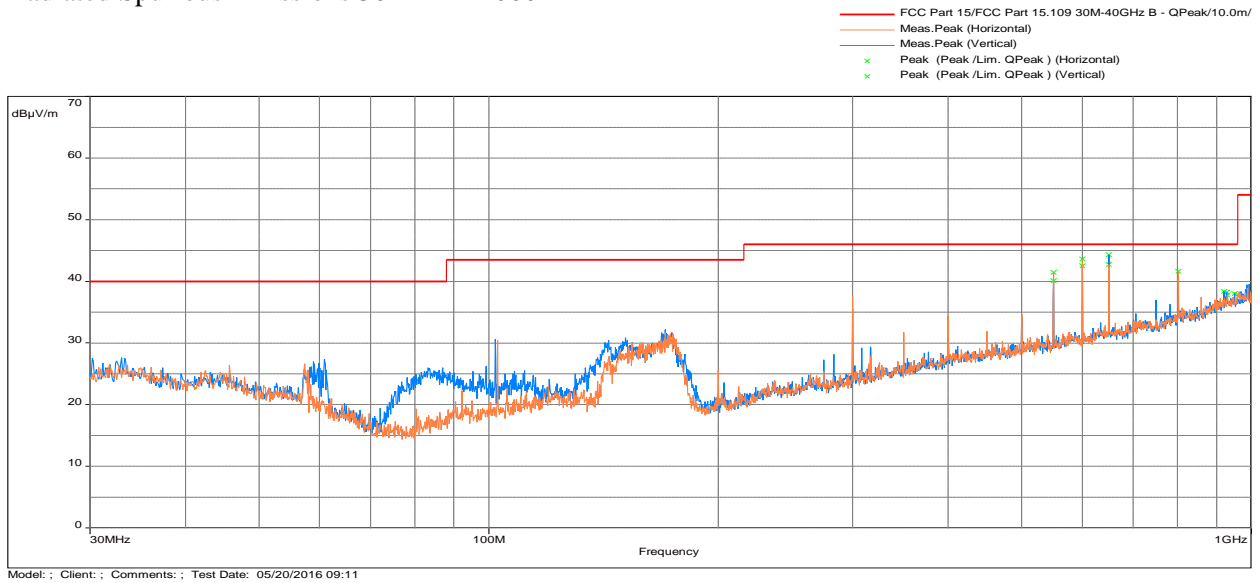

Radiated Spurious Emissions 1000 - 18000 MHz, Average Scan

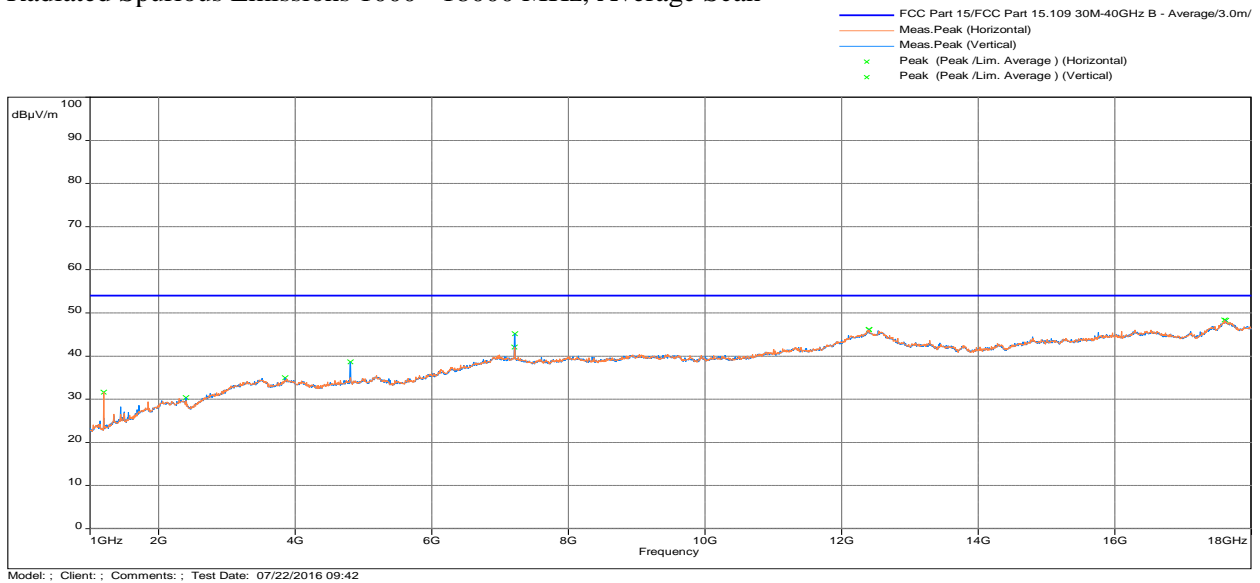



## Radiated Spurious Emissions 1000 - 18000 MHz, Peak Scan

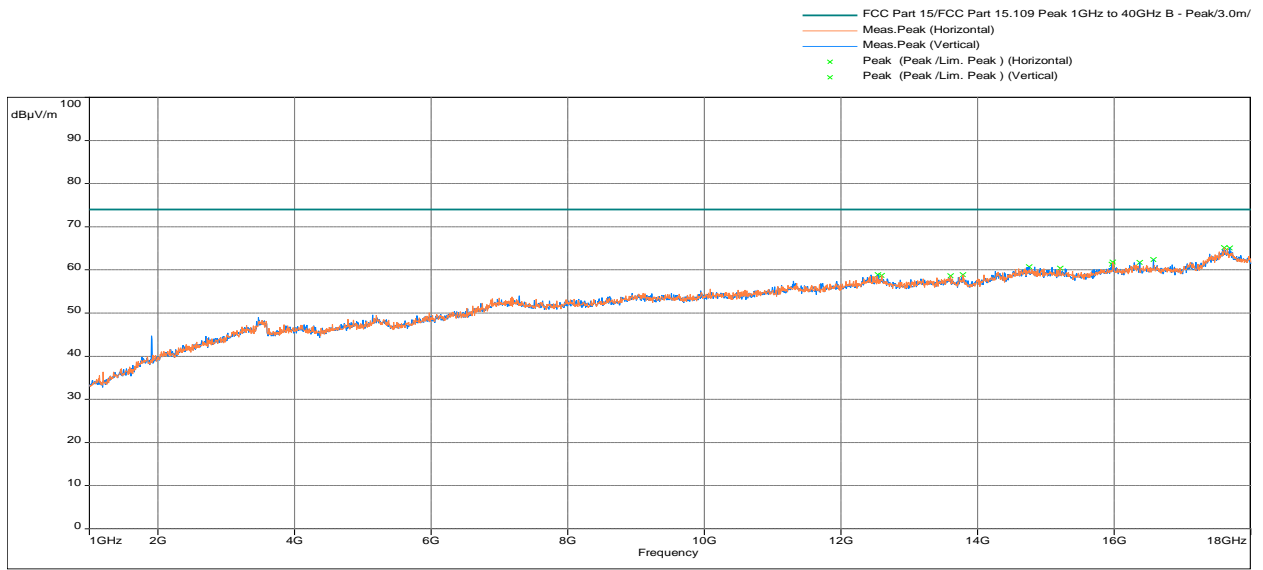



Test Results: 15.209 Radiated Spurious Emissions Mid Channel, Tx at 2440MHz

### Radiated Spurious Emissions 30 MHz - 1000 MHz

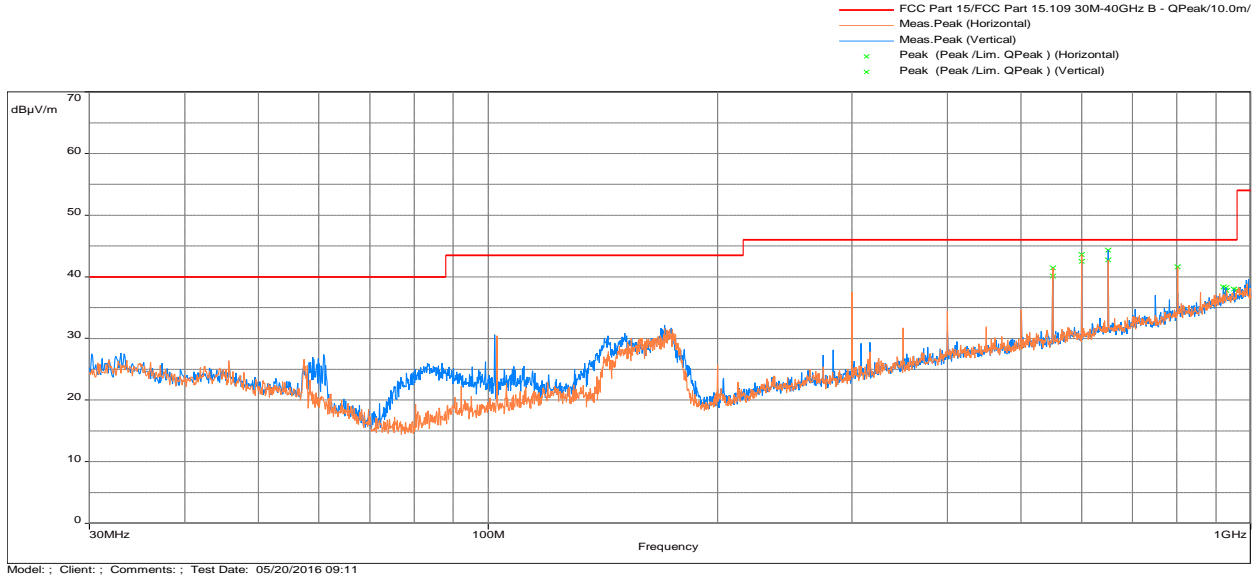

### Radiated Spurious Emissions 1000 - 18000 MHz, Average Scan

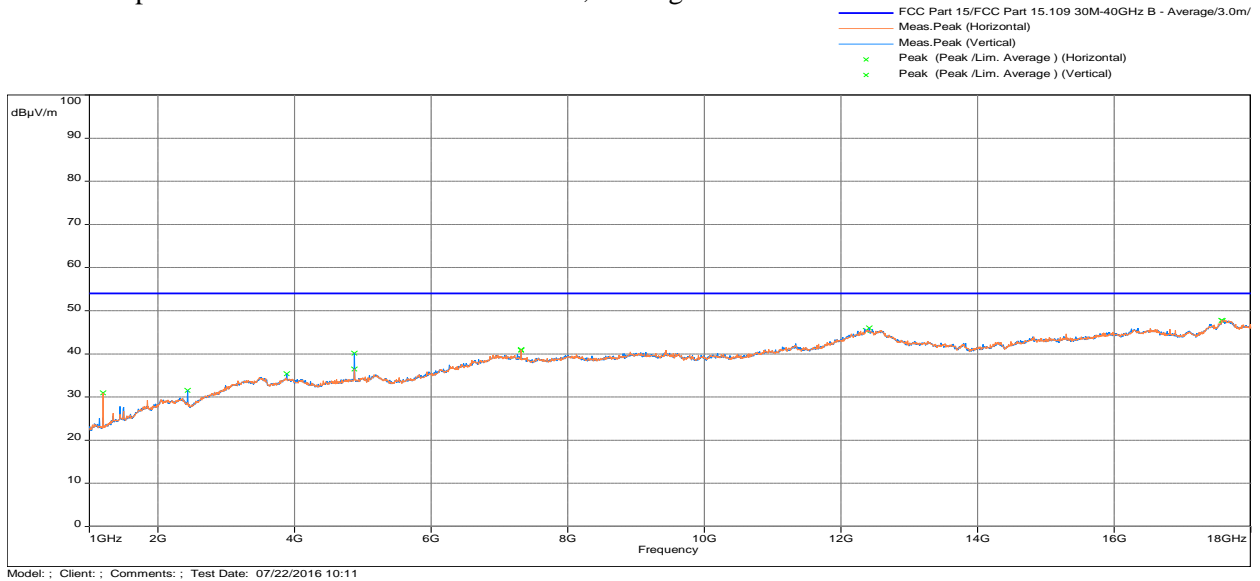



### Radiated Spurious Emissions 1000 - 18000 MHz, Peak Scan

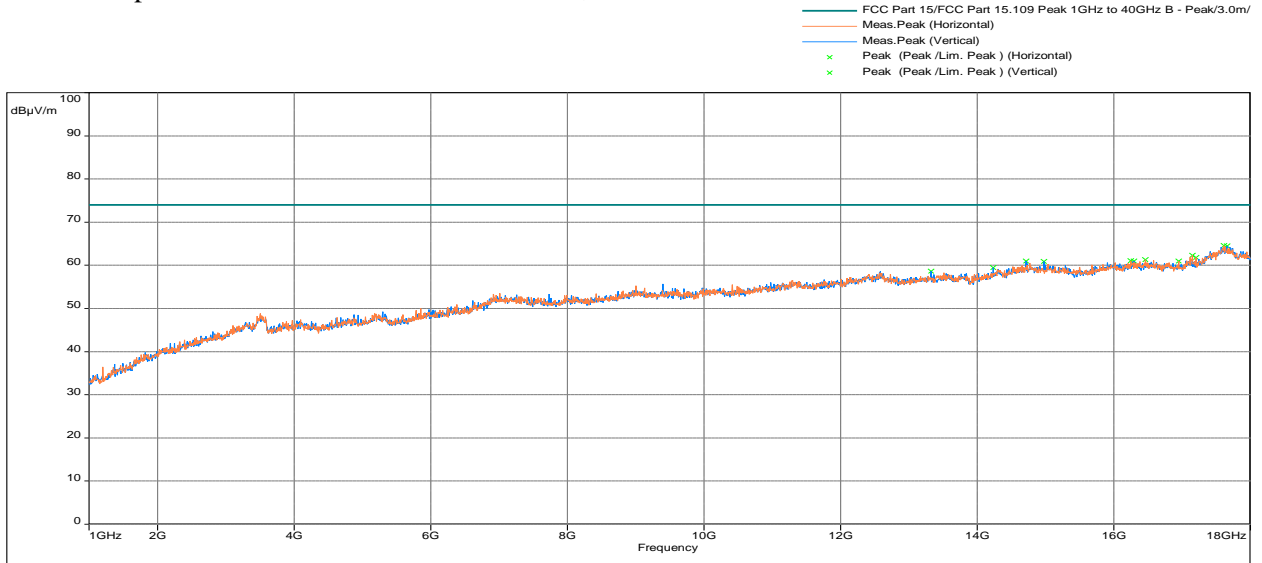





Test Results: 15.209 Radiated Spurious Emissions High Channel, Tx at 2480MHz

Radiated Spurious Emissions 30 MHz - 1000 MHz

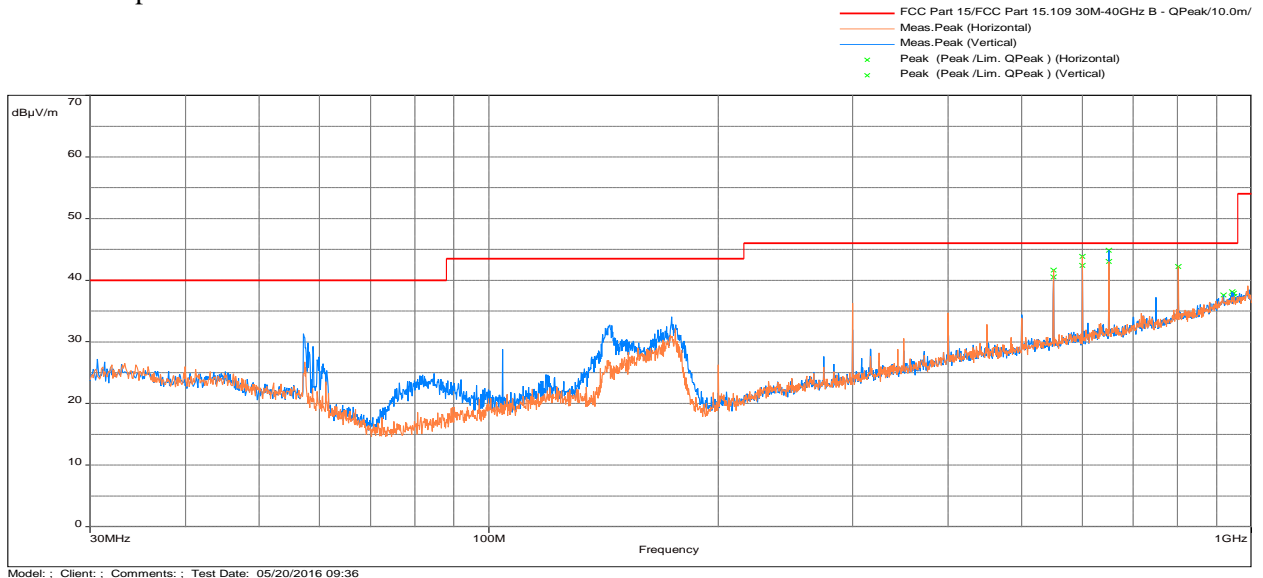

Radiated Spurious Emissions 1000 - 18000 MHz, Average Scan

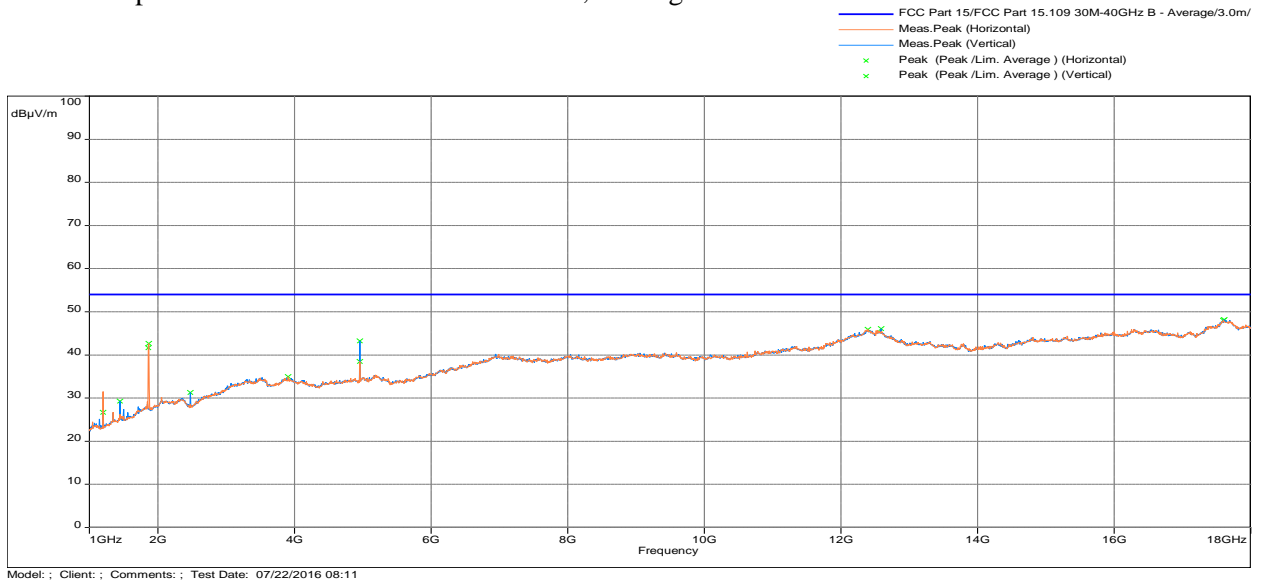



## Radiated Spurious Emissions 1000 - 18000 MHz, Peak Scan

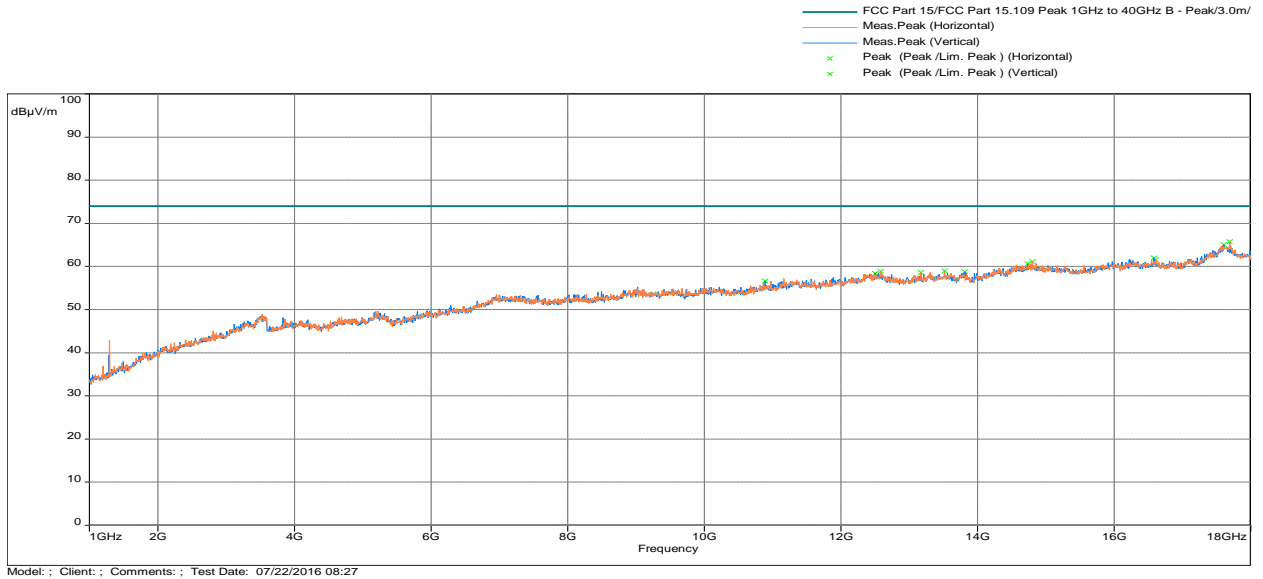

<b>Results</b>	<b>Complies</b>
----------------	-----------------

4.5.8 Test setup photographs

The following photographs show the testing configurations used.



4.5.5 Test setup photographs (Continued)

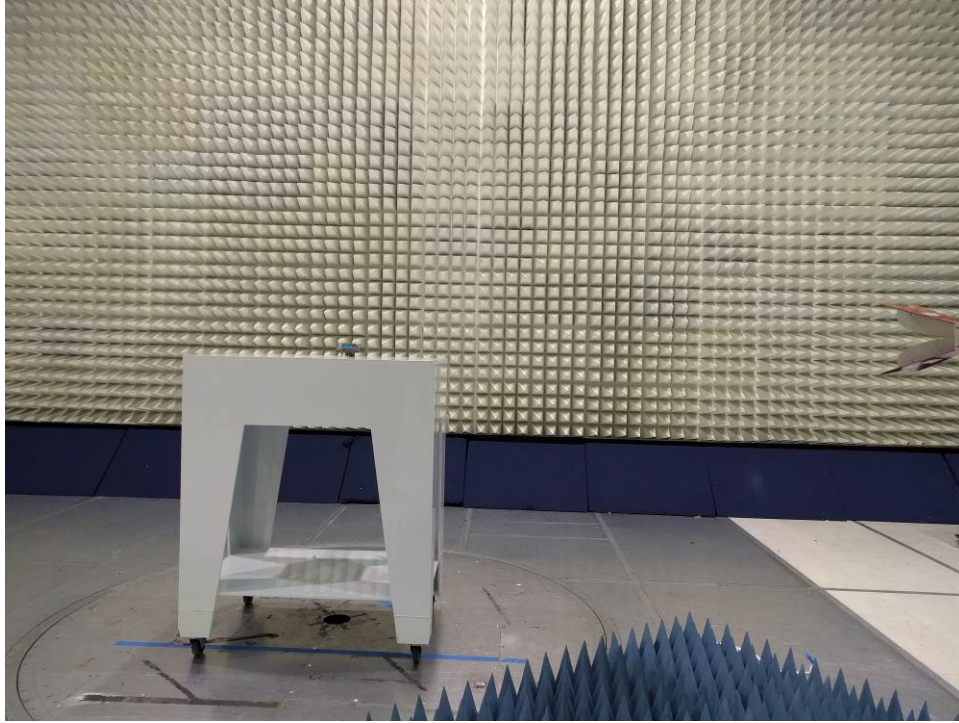

#### 4.6 Radiated Emissions

FCC Ref: 15.109, ICES 003

##### 4.6.1 Requirement

***Limits for Electromagnetic Radiated Emissions FCC Section 15.109(b), ICES 003\*, RSS GEN***

<b>Frequency (MHz)</b>	<b>Class A at 10m dB(<math>\mu</math>V/m)</b>	<b>Class B at 3m dB(<math>\mu</math>V/m)</b>
30-88	39	40.0
88-216	43.5	43.5
216-960	46.4	46.0
Above 960	49.5	54.0

\* According to FCC Part 15.109(g) an alternative to the radiated emission limits shown above, digital devices may be shown to comply with the limit of CISPR Pub. 22

#### 4.6.2 Procedures

Measurements are conducted with a quasi-peak detector instrument in the frequency range of 30 MHz to 1000 MHz and with the average detector instrument in the frequency range above 1000 MHz. The measuring receiver meets the requirements of Section One of CISPR 16 and the measuring antenna correlates to a balanced dipole.

Measurements of the radiated field are made with the antenna located at a distance of 10 meters from the EUT. If the field-strength measurements at 10m cannot be made because of high ambient noise level or for other reasons, measurements of Class B equipment may be made at a closer distance, for example 3m. An inverse proportionality factor of 20 dB per decade should be used to normalize the measured data to the specified distance for determining compliance.

The antenna is adjusted between 1m and 4m in height above the ground plane for maximum meter reading at each test frequency.

The antenna-to-EUT azimuth is varied during the measurement to find the maximum field-strength readings.

The antenna-to-EUT polarization (horizontal and vertical) is varied during the measurements to find the maximum field-strength readings.

The EUT, where intended for tabletop use, is placed on a table whose top is 0.8m above the ground plane. The table is constructed of non-conductive materials. Its dimensions are 1m by 1.5m, but may be extended for a larger EUT.

Floor standing EUT are placed on a horizontal metal ground plane and isolated from the ground plane by resting on an insulating material.

Equipment setup for radiated disturbance tests followed the guidelines of ANSI C63.4 and EN 55022.

#### 4.6.3 Test Results

Radiated emission measurements were performed from 30 MHz to 25 GHz. No Emissions were identified when scanned from 1-25 GHz. The data on the following pages list the significant emission frequencies, the limit and the margin of compliance.

<b>Date of Test:</b> May 20, 2016
-----------------------------------

Test Results: Radiated Emissions 30 MHz – 1000 MHz  
 Test Results: 15.109 Radiated Spurious Emissions Class A

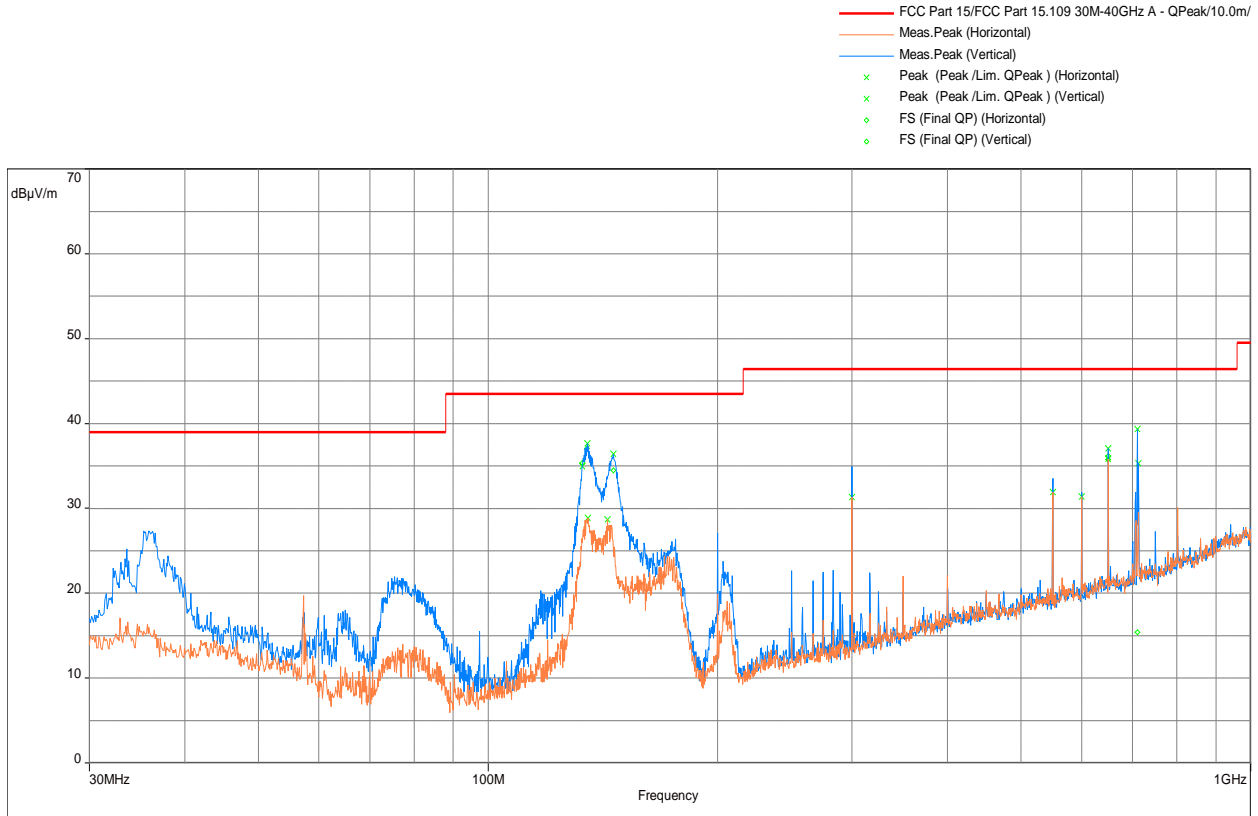

Model: ; Client: ; Comments: ; Test Date: 05/20/2016 10:50

Frequency (MHz)	FS (dBµV/m)	Limit (dB(uV/m))	Margin (dB)	Azimuth (deg)	Height (m)	Polarity	RA (dBuV)	Correction (dB)
649.995	35.77	46.4	-10.63	52	1.58	Horizontal	45.07	-9.30
132.951	35.36	43.5	-8.14	273	2.23	Vertical	55.33	-20.00
134.633	37.08	43.5	-6.42	283	1.24	Vertical	57.53	-20.39
146.046	34.45	43.5	-9.05	302	1.37	Vertical	56.88	-22.45
649.995	36.15	46.4	-10.25	69	1.00	Vertical	45.45	-9.30
710.116	15.39	46.4	-31.01	227	3.80	Vertical	23.73	-8.34

**Results** Complies by 6.42 dB



4.6.4 Test Configuration Photographs

The following photographs show the testing configurations used.

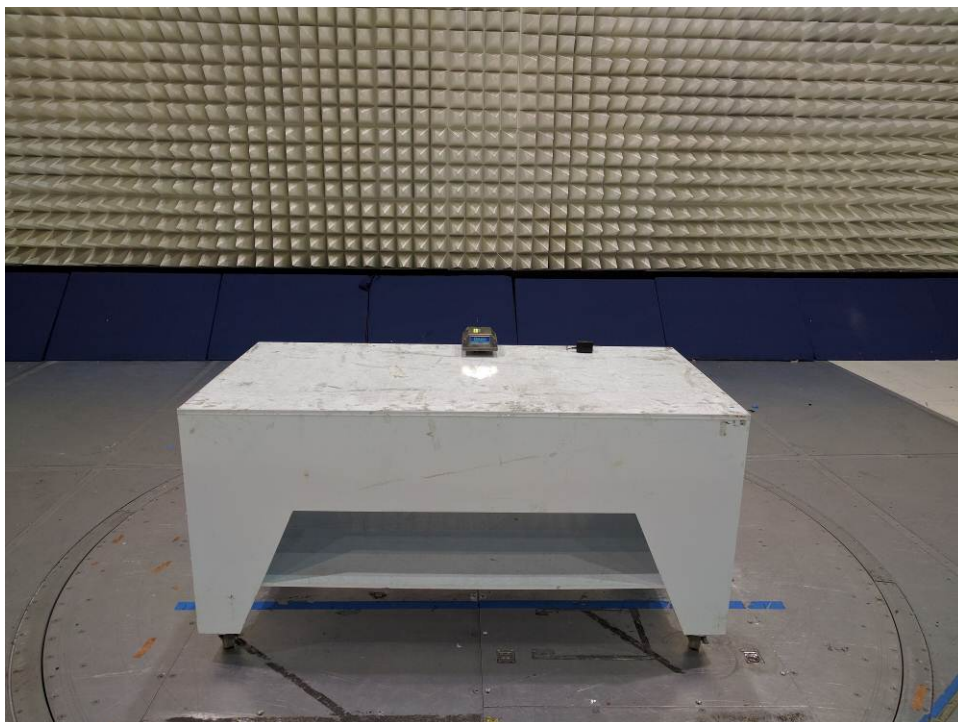



4.7 AC Line Conducted Emission  
FCC: 15.207, 15.107; RSS-GEN;

4.7.1 Requirement

Frequency Band MHz	FCC 15.207 Limit dB(μV)		FCC 15.107 Class A Limit dB(μV)	
	Quasi-Peak	Average	Quasi-Peak	Average
0.15-0.50	66 to 56 *	56 to 46 *	79	66
0.50-5.00	56	46	73	60
5.00-30.00	60	50	73	60

Note: \*Decreases linearly with the logarithm of the frequency. At the transition frequency the lower limit applies.

4.7.2 Procedure

Measurements are carried out using quasi-peak and average detector receivers in accordance with CISPR 16. An AMN is required to provide a defined impedance at high frequencies across the power feed at the point of measurement of terminal voltage and also to provide isolation of the circuit under test from the ambient noise on the power lines. An AMN as defined in CISPR 16 shall be used.

The EUT is located so that the distance between the boundary of the EUT and the closest surface of the AMN is 0.8m.

Where a flexible mains cord is provided by the manufacturer, this shall be 1m long or if in excess of 1m, the excess cable is folded back and forth as far as possible so as to form a bundle not exceeding 0.4m in length.

The EUT is arranged and connected with cables terminated in accordance with the product specification.

Conducted disturbance is measured between the phase lead and the reference ground, and between the neutral lead and the reference ground. Both measured values are reported.

The EUT, where intended for tabletop use, is placed on a table whose top is 0.8m above the ground plane. A vertical, metal reference plane is placed 0.4m from the EUT. The vertical metal reference-plane is at least 2m by 2m. The EUT shall be kept at least 0.8m from any other metal surface or other ground plane not being part of the EUT. The table is constructed of non-conductive materials. Its dimensions are 1m by 1.5m, but may be extended for larger EUT.

Floor standing EUT are placed on a horizontal metal ground plane and isolated from the ground plane by resting on an insulating material. The metal ground plane extends at least 0.5m beyond the boundaries of the EUT and has minimum dimensions of 2m by 2m.

Equipment setup for conducted disturbance tests followed the guidelines of ANSI C63.4 & ANSI C63.10.

<b>Date of Test:</b>	May 20, 2016
<b>Results</b>	<b>Complies</b>

### 4.7.3 Test Result

#### AC Line Conducted Emission Data, EUT in transmission off (15.107)

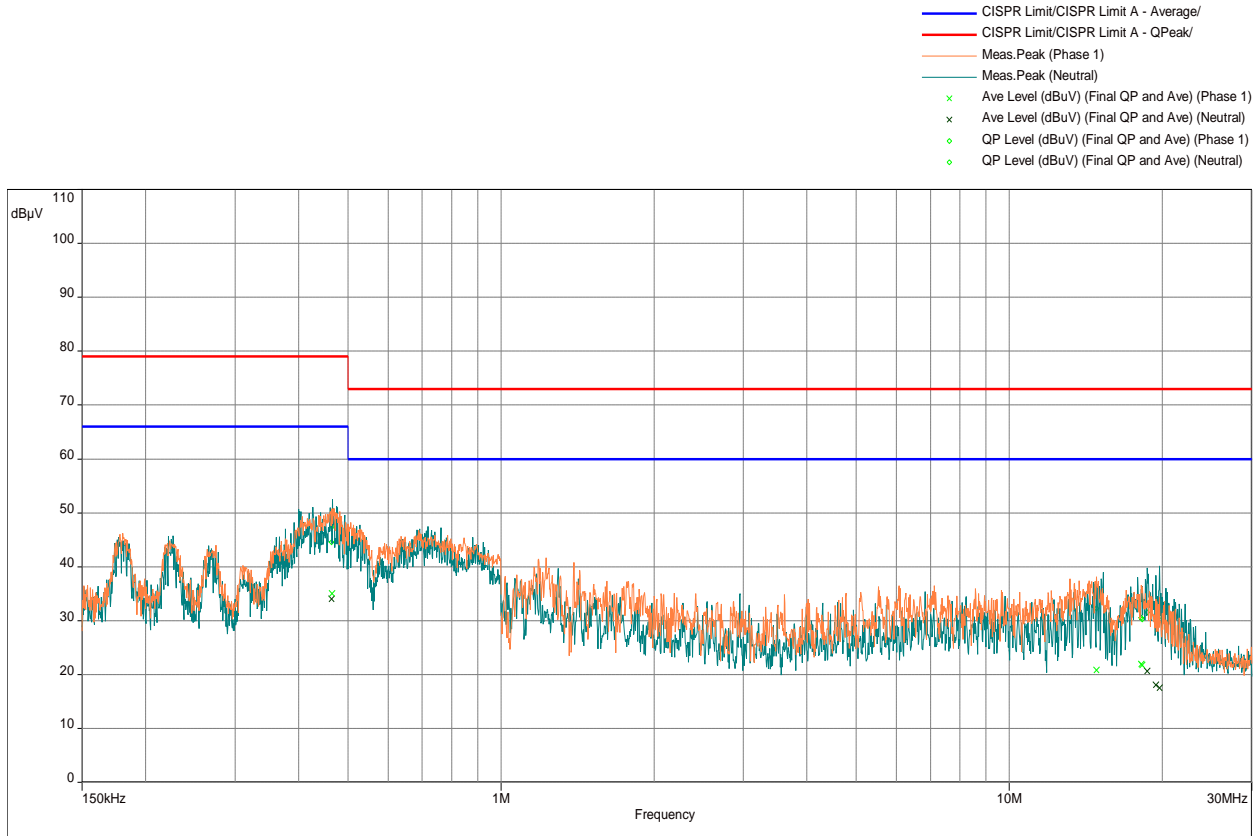

Model: ; Client: ; Comments: ; Test Date: 05/20/2016 12:06

Frequency (MHz)	Ave Level (dBuV)	QP Level (dBuV)	Ave Limit (dBuV)	QP Limit (dBuV)	Ave Margin (dB)	QP Margin (dB)	Line	Correction (dB)
0.466	34.98	47.44	66.00	79.00	-31.02	-31.56	Phase 1	11.13
14.840	20.85	32.24	67.86	79.68	-47.00	-47.43	Phase 1	11.51
18.185	21.96	30.51	65.59	77.75	-43.63	-47.24	Phase 1	11.55
18.274	21.76	30.23	65.53	77.70	-43.78	-47.47	Phase 1	11.55
0.464	34.01	44.54	66.00	79.00	-31.99	-34.46	Neutral	11.13
18.670	20.63	31.59	65.29	77.50	-44.67	-45.91	Neutral	11.55
19.438	18.04	30.61	64.84	77.12	-46.80	-46.51	Neutral	11.56
19.732	17.53	30.71	64.68	76.98	-47.15	-46.26	Neutral	11.57

**Results** Complies by 31.02 dB

4.7.3 Test Result (Continued)

**AC Line Conducted Emission Data, EUT in transmission on (15.207)**

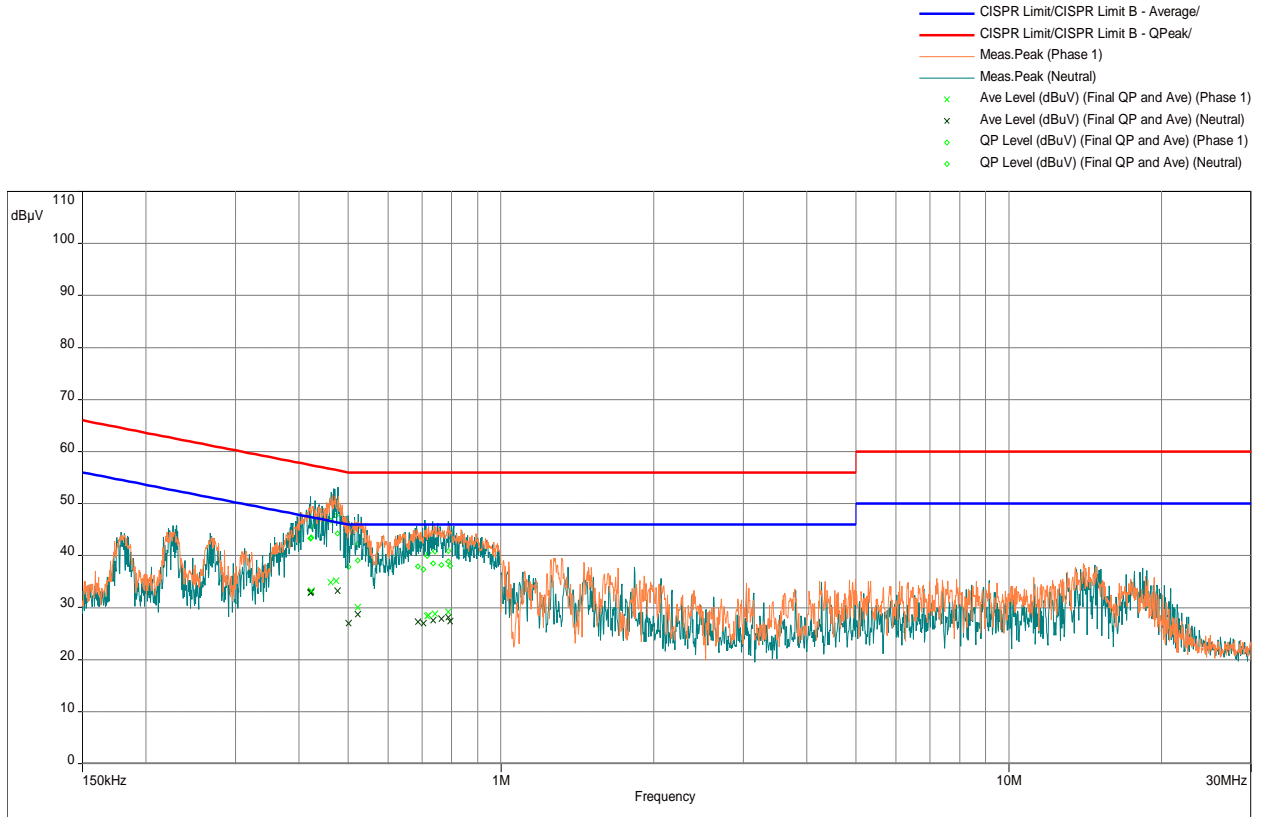

Model ; Client ; Comments ; Test Date: 05/20/2016 12:17

Frequency (MHz)	Ave Level (dBuV)	QP Level (dBuV)	Ave Limit (dBuV)	QP Limit (dBuV)	Ave Margin (dB)	QP Margin (dB)	Line	Correction (dB)
0.423	33.18	45.67	47.39	57.39	-14.21	-11.72	Phase 1	11.13
0.462	34.82	46.79	46.66	56.66	-11.84	-9.87	Phase 1	11.13
0.474	35.12	47.68	46.45	56.45	-11.33	-8.78	Phase 1	11.13
0.523	30.01	42.26	46.00	56.00	-15.99	-13.74	Phase 1	11.12
0.716	28.36	39.94	46.00	56.00	-17.64	-16.06	Phase 1	11.12
0.721	28.53	40.48	46.00	56.00	-17.47	-15.52	Phase 1	11.12
0.742	28.80	40.82	46.00	56.00	-17.20	-15.18	Phase 1	11.12
0.787	29.23	40.92	46.00	56.00	-16.77	-15.08	Phase 1	11.13
0.421	32.82	43.33	47.42	57.42	-14.60	-14.09	Neutral	11.13
0.423	32.91	43.38	47.39	57.39	-14.48	-14.01	Neutral	11.13
0.424	33.02	43.53	47.38	57.38	-14.36	-13.85	Neutral	11.13
0.477	33.24	44.27	46.39	56.39	-13.15	-12.12	Neutral	11.13
0.502	26.99	37.82	46.00	56.00	-19.01	-18.18	Neutral	11.12
0.522	28.74	39.09	46.00	56.00	-17.26	-16.91	Neutral	11.12
0.687	27.23	37.93	46.00	56.00	-18.77	-18.07	Neutral	11.12
0.704	27.00	37.38	46.00	56.00	-19.00	-18.62	Neutral	11.12
0.735	27.56	38.50	46.00	56.00	-18.44	-17.50	Neutral	11.12
0.763	27.87	38.20	46.00	56.00	-18.13	-17.80	Neutral	11.13
0.787	28.13	38.90	46.00	56.00	-17.87	-17.10	Neutral	11.13
0.795	27.34	37.98	46.00	56.00	-18.66	-18.02	Neutral	11.13

<b>Results</b>	<b>Complies by 8.78 dB</b>
----------------	----------------------------

#### 4.6.4 Test Configuration Photographs

The following photographs show the testing configurations used.



## 5.0 RF Exposure Evaluation

### MPE Evaluation

The EUT is a wireless device used in a mobile application, at least 20 cm from any body part of the user or nearby persons.

The maximum Peak EIRP calculated is 8.23 dBm (RF Conducted Power) + (- 5 dBi )(Antenna Gain) = 3.23 dBm or 2.104 mW; therefore, to comply with RF Exposure Requirement, the MPE is calculated.

The Power Density can be calculated using the formula

$$S = \text{EIRP} / 4\pi D^2$$

Where: S is Power Density in mW/cm<sup>2</sup>  
D is the distance from the antenna.

It is considered that 20 cm is the minimum distance that user can go closest to the EUT.

At 20 cm, S =0.00419 W/m<sup>2</sup>, which is below the MPE Limit of 10 W/m<sup>2</sup>

<b>Date of Test:</b>	July 25, 2016
<b>Results</b>	<b>Complies</b>

## 6.0 List of Test Equipment

Measurement equipment used for emission compliance testing utilized the equipment on the following list:

Revision 1.0 and 2.0:

<b>Equipment</b>	<b>Manufacturer</b>	<b>Model/Type</b>	<b>Asset #</b>	<b>Cal Int</b>	<b>Cal Due</b>
EMI Receiver	Rohde and Schwarz	ESU	ITS 00961	12	07/07/17
BI-Log Antenna	ARA	LPB-2513/A	ITS 00355	12	09/11/16
Pyramidal Horn Antenna	EMCO	3160-09	ITS00571	#	#
Pre-Amplifier	Sonoma Instrument	310N	ITS 00942	12	04/13/17
Pre-Amplifier (18-40GHz)	Miteq	TTA1840-35-S-M	ITS 01393	12	01/07/17
Active Horn Antenna	ETS-Lindgren	3117-PA	ITS 01365	12	10/15/16
LISN	FCC	FCC-LISN-50-50-M-H	ITS 00551	12	06/09/17

# No Calibration required

## 7.0 Document History

<b>Revision/ Job Number</b>	<b>Writer Initials</b>	<b>Reviewers Initials</b>	<b>Date</b>	<b>Change</b>
1.0 / G102502245	AC	KV	August 05, 2016	Original document
2.0 / G102502245	AC	KV	August 31, 2016	Added Apendix A for additional testing for Model Number TSII-CONTRL3



## Appendix A: Additional testing for model TSII-CONTRL3

A.1 Transmitter Radiated Emissions  
FCC Rules: 15.247(d), 15.209, 15.205; RSS-247;

### A.1.1 Requirement

Radiated emissions which fall in the restricted bands, as defined in §15.205(a), must also comply with the radiated emission limits specified in §15.209(a) (see §15.205(c)).

For out of band radiated emissions (except for frequencies in restricted bands), in any 100 kHz bandwidths outside the EUT pass-band, the RF power shall be at least 20dB (peak) or 30 dB (average) below that of the maximum in-band 100 kHz emissions.

### A.1.2 Procedure

Radiated emission measurements were performed from 30 MHz to 25 GHz according to the procedure described in ANSI C63.10. Spectrum Analyzer Resolution Bandwidth is 100 kHz or greater for frequencies 30 MHz to 1000 MHz, 1 MHz for frequencies above 1000 MHz. Above 1000 MHz Peak and Average measurements were performed.

The EUT is placed on a plastic turntable that is 80 cm in height for below 1000MHz and 1.5m in height for above 1GHz. If the EUT attaches to peripherals, they are connected and operational (as typical as possible). During testing, all cables were manipulated to produce worst-case emissions. The signal is maximized through rotation. The antenna height and polarization are varied during the search for maximum signal level. The antenna height is varied from 1 to 4 meters.

Radiated emissions are taken at 3 meters for frequencies above 1 GHz and at 10 meters for frequencies below 1 GHz.

Measurements made from 1 GHz to 18GHz had a 2.4-2.5GHz notch filter in place. A preamp was used from 30MHz to 25GHz.

All measurements were made with a Peak Detector and compared to QP limits for 30MHz – 1GHz and Average limits for 1GHz – 25GHz.

Data is included of the worst-case configuration (the configuration which resulted in the highest emission levels).

### A.1.3 Field Strength Calculation

#### Field Strength Calculation

The field strength is calculated by adding the Antenna Factor and Cable Factor, and subtracting the Amplifier Gain (if any) from the measured reading. The basic equation with a sample calculation is as follows:

$FS = RA + AF + CF - AG$ ; if measurement is performed at a distance other than specified in the rule, a Distance Correction Factor (DCF) shall be added.

Where FS = Field Strength in dB( $\mu$ V/m)

RA = Receiver Amplitude (including preamplifier) in dB( $\mu$ V); AF = Antenna Factor in dB(1/m)

CF = Cable Attenuation Factor in dB; AG = Amplifier Gain in dB

Assume a receiver reading of 52.0 dB( $\mu$ V) is obtained. The antennas factor of 7.4 dB(1/m) and cable factor of 1.6 dB is added. The amplifier gain of 29 dB is subtracted, giving field strength of 32 dB( $\mu$ V/m). This value in dB( $\mu$ V/m) was converted to its corresponding level in  $\mu$ V/m.

RA = 52.0 dB( $\mu$ V)

AF = 7.4 dB(1/m)

CF = 1.6 dB

AG = 29.0 dB

$FS = 52.0 + 7.4 + 1.6 - 29.0 = 32$  dB( $\mu$ V/m).

Level in  $\mu$ V/m = Common Antilogarithm [ $(32 \text{ dB}\mu\text{V/m})/20$ ] = 39.8  $\mu$ V/m.

#### A.1.4 Antenna-port conducted measurements

Antenna-port conducted measurements may also be used as an alternative to radiated measurements for demonstrating compliance in the restricted frequency bands. If conducted measurements are performed, then proper impedance matching must be ensured and an additional radiated test for cabinet/case spurious emissions is required.

#### A.1.5 General Procedure for conducted measurements in restricted bands

- a) Measure the conducted output power (in dBm) using the detector specified for determining quasi-peak, peak, and average conducted output power, respectively.
- b) Add the maximum transmit antenna gain (in dBi) to the measured output power level to determine the EIRP level (see 12.2.5 for guidance on determining the applicable antenna gain)
- c) Add the appropriate maximum ground reflection factor to the EIRP level (6 dB for frequencies  $\leq 30$  MHz, 4.7 dB for frequencies between 30 MHz and 1000 MHz, inclusive and 0 dB for frequencies  $> 1000$  MHz).
- d) For devices with multiple antenna-ports, measure the power of each individual chain and sum the EIRP of all chains in linear terms (*e.g.*, Watts, mW).
- e) Convert the resultant EIRP level to an equivalent electric field strength using the following relationship:  
 $E = \text{EIRP} - 20\log D + 104.8$   
where:  
E = electric field strength in dB $\mu$ V/m,  
EIRP = equivalent isotropic radiated power in dBm  
D = specified measurement distance in meters.
- f) Compare the resultant electric field strength level to the applicable limit.
- g) Perform radiated spurious emission test

#### A.1.6 Test Results

The data on the following pages list the significant emission frequencies, the limit and the margin of compliance where emissions are within 3dB of the limit.

If conducted measurements were performed, all conducted antenna port plots are corrected with the consideration of the EUT's Antenna Gain (minimum 2 dBi).

Radiated emission measurements were performed up to 25GHz. No Emissions were identified when scanned from 18-25 GHz.

<b>Date of Test:</b>	August 10, 2016
<b>Results</b>	<b>Complies</b>



**Test Results: 15.209/15.205 Restricted Band Emissions (Radiated Method)**

**Out-of-Band Spurious Emissions at the Band Edge – Tx @ 2405 MHz**

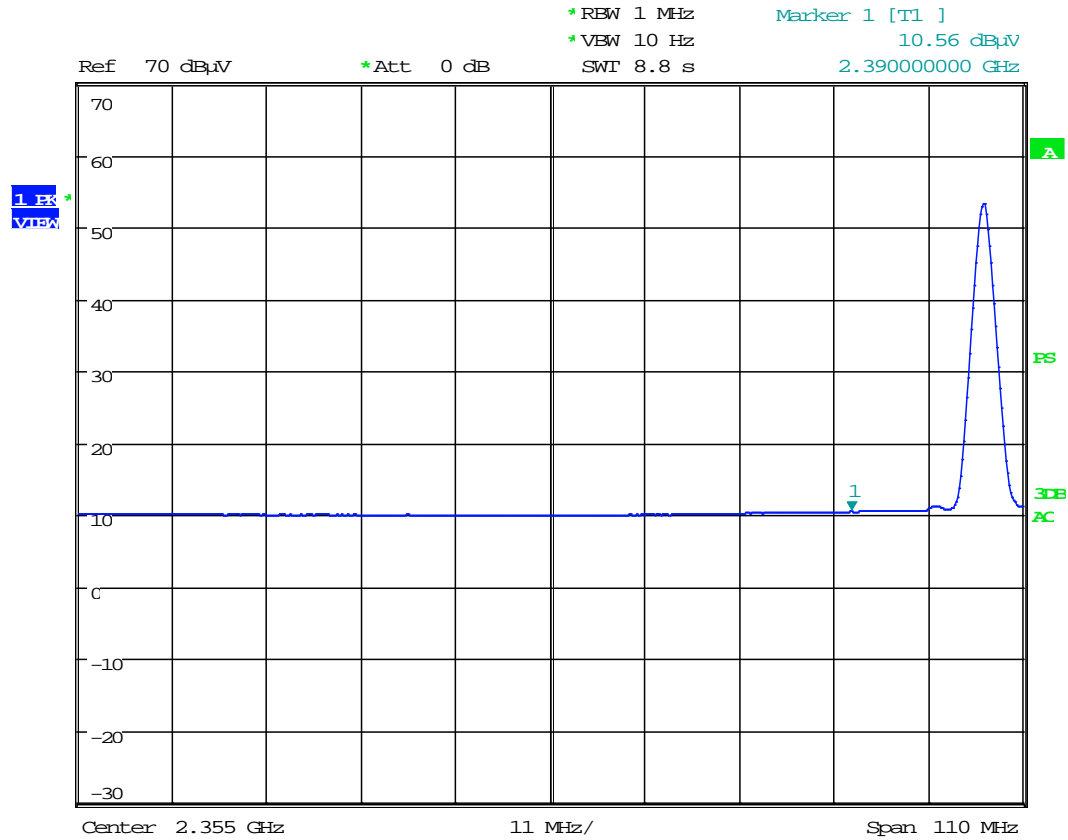

Date: 10.AUG.2016 21:34:08

Frequency	Raw Amplitude at 3m	Correction Factor	Corrected Amplitude	Peak Limit	Margin	Detector	Results
GHz	dBμV/m	dB	dBμV/m	dBμV/m	dB	Avg	Pass
2.390	10.56	32.3	42.86	54	-11.14		

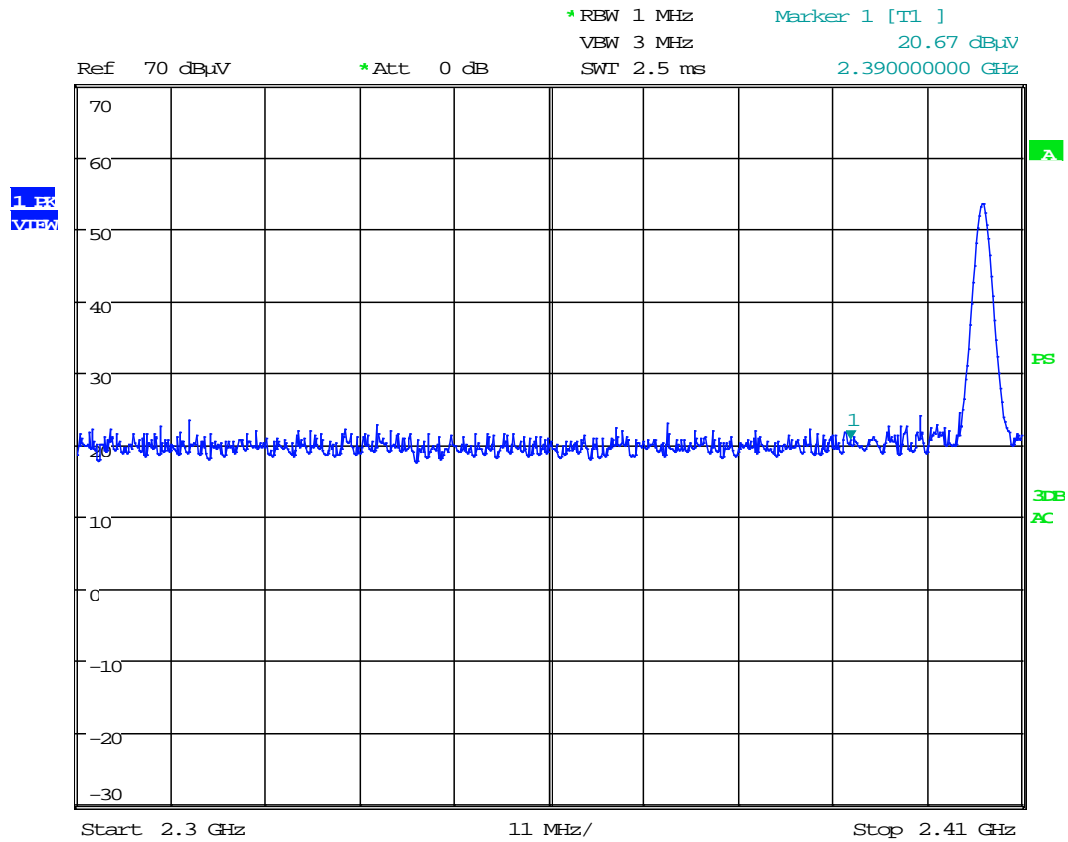

Date: 10.AUG.2016 21:32:41

Frequency	Raw Amplitude at 3m	Correction Factor	Corrected Amplitude	Peak Limit	Margin	Detector	Results
GHz	dBμV/m	dB	dBμV/m	dBμV/m	dB	Peak	Pass
2.390	20.67	32.3	52.97	74	-21.03		



### Out-of-Band Spurious Emissions at the Band Edge – Tx @ 2480 MHz

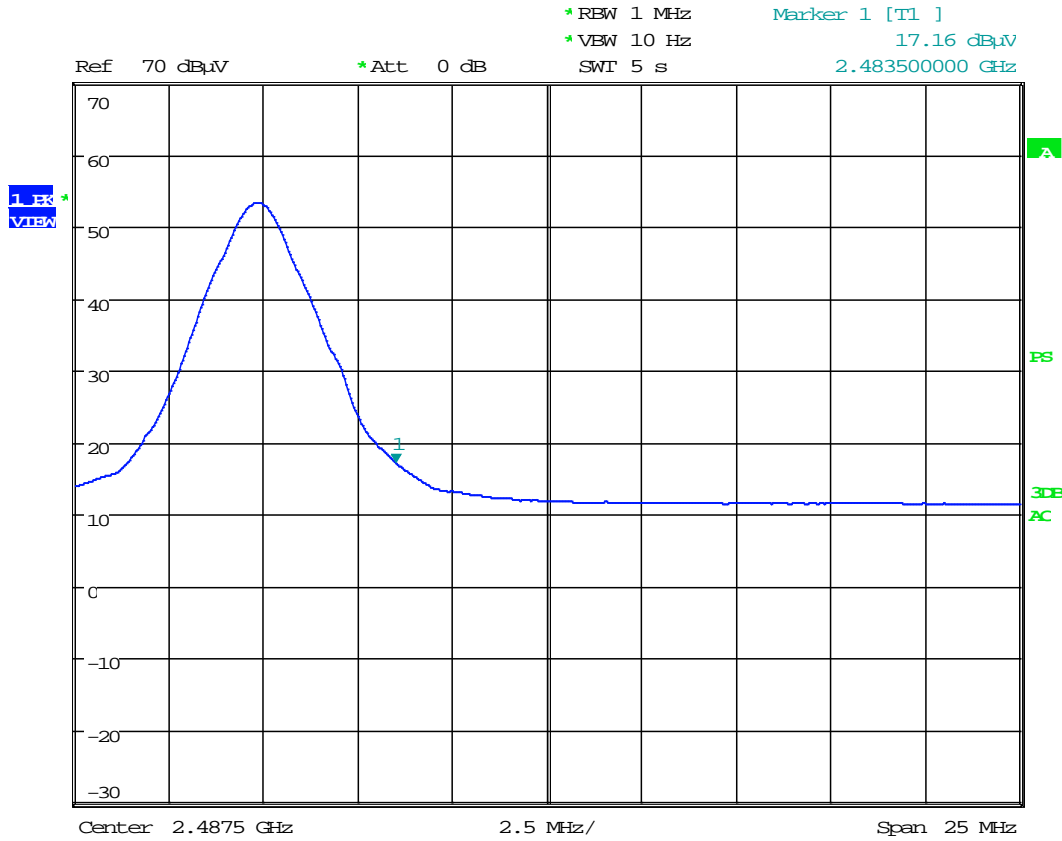

Date: 10.AUG.2016 21:29:02

Frequency	Raw Amplitude at 3m	Correction Factor	Corrected Amplitude	Peak Limit	Margin	Detector	Results
GHz	dBµV/m	dB	dBµV/m	dBµV/m	dB	Avg	Pass
2.4835	17.16	32.3	49.46	54	-4.54		

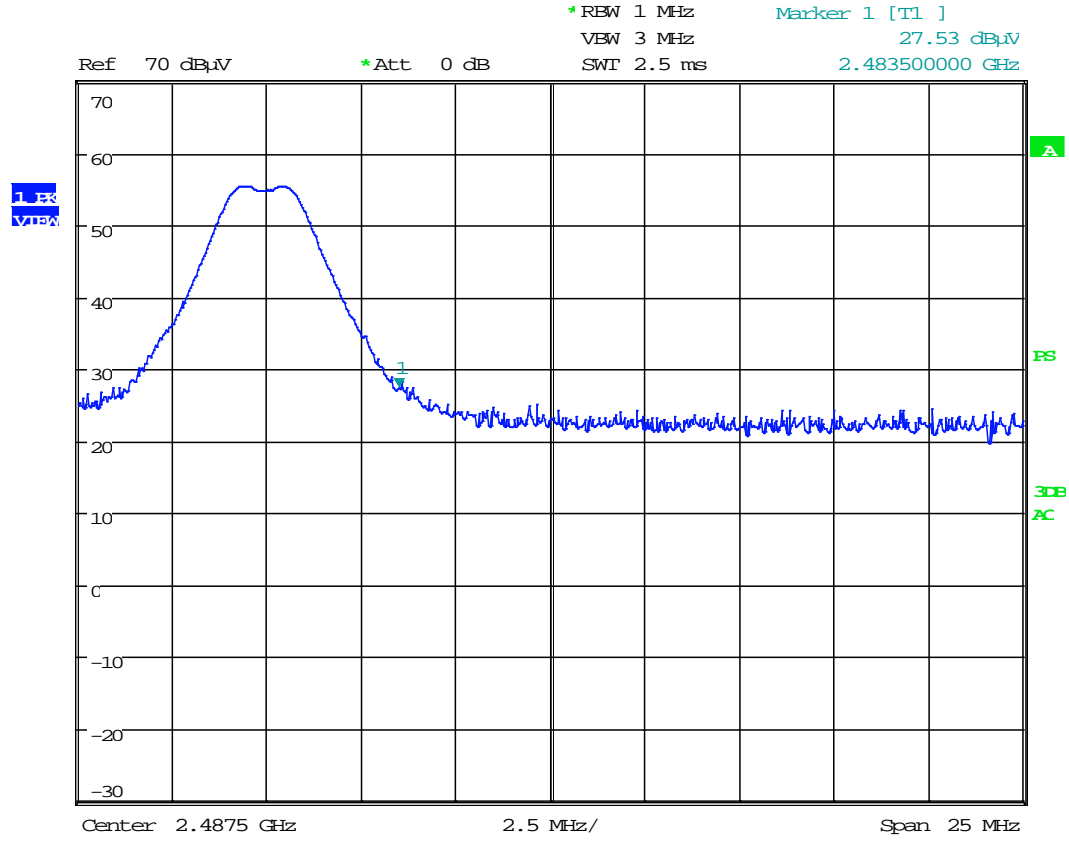

Date: 10.AUG.2016 21:26:27

Frequency	Raw Amplitude at 3m	Correction Factor	Corrected Amplitude	Peak Limit	Margin	Detector	Results
GHz	dBμV/m	dB	dBμV/m	dBμV/m	dB	Peak	Pass
2.4835	27.53	32.3	59.83	74	-14.17		

### Out-of-Band Radiated Spurious Emissions (Radiated Method)

Test Results: 15.209 Radiated Spurious Emissions Low Channel, Tx at 2405MHz

#### Radiated Spurious Emissions 30 MHz - 1000 MHz

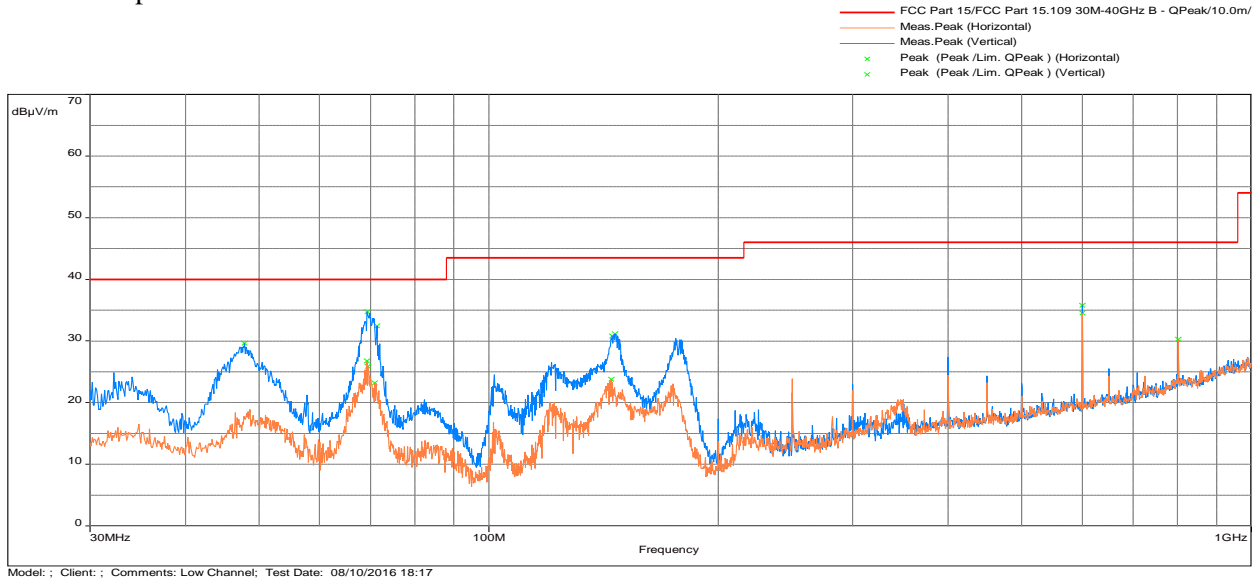

#### Radiated Spurious Emissions 1000 - 18000 MHz, Average Scan







## Radiated Spurious Emissions 1000 - 18000 MHz, Peak Scan

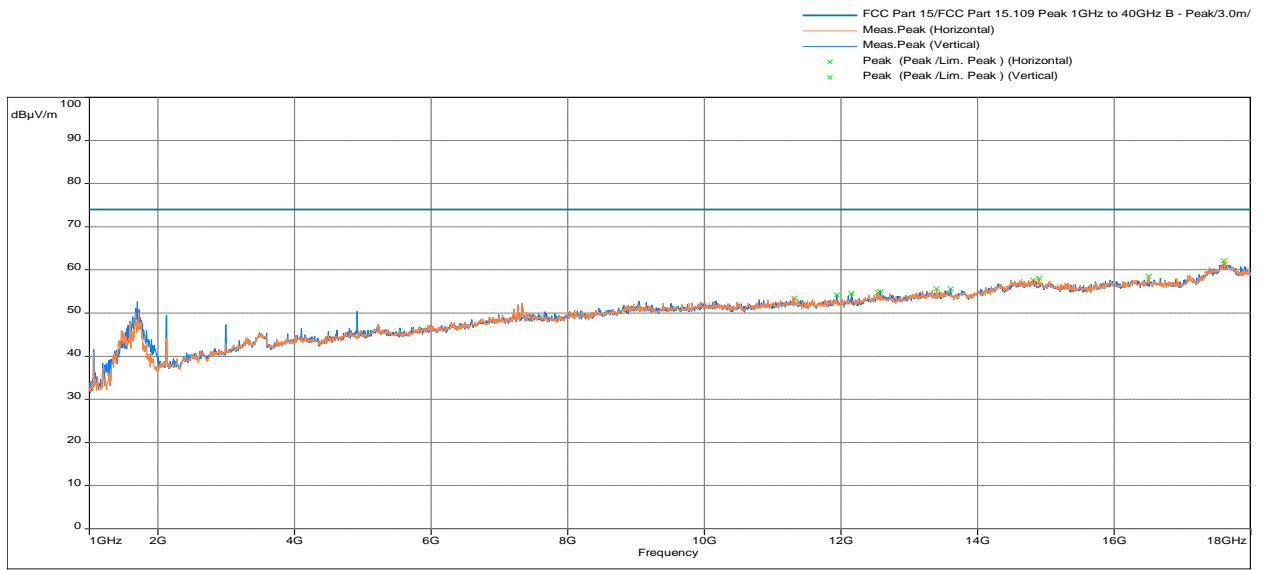

Test Results: 15.209 Radiated Spurious Emissions Mid Channel, Tx at 2440MHz

Radiated Spurious Emissions 30 MHz - 1000 MHz

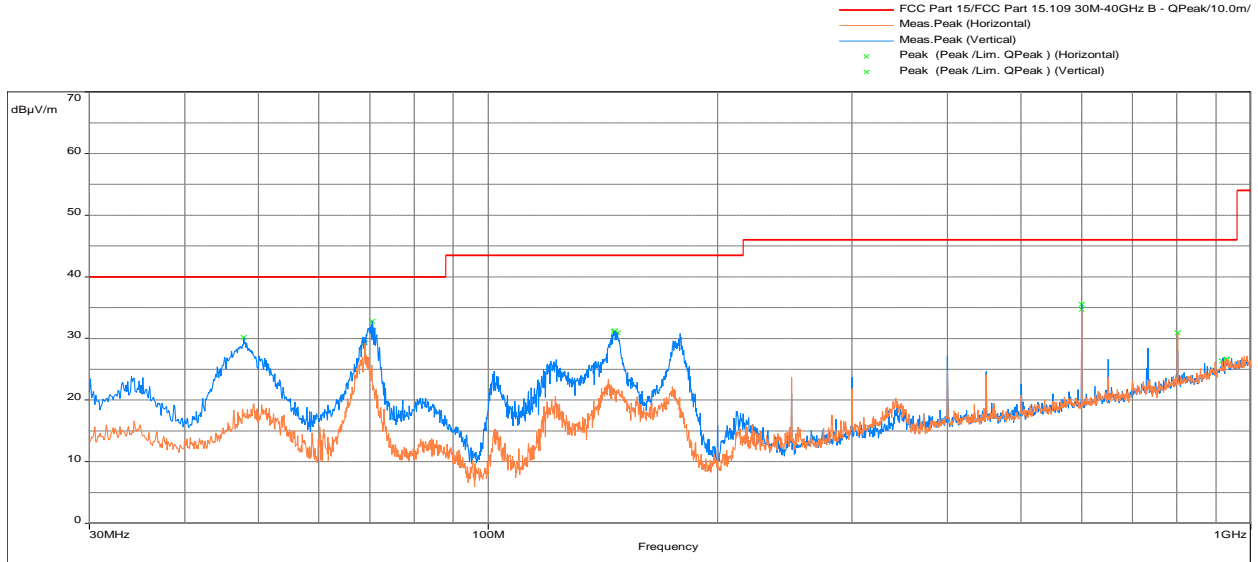

Radiated Spurious Emissions 1000 - 18000 MHz, Average Scan

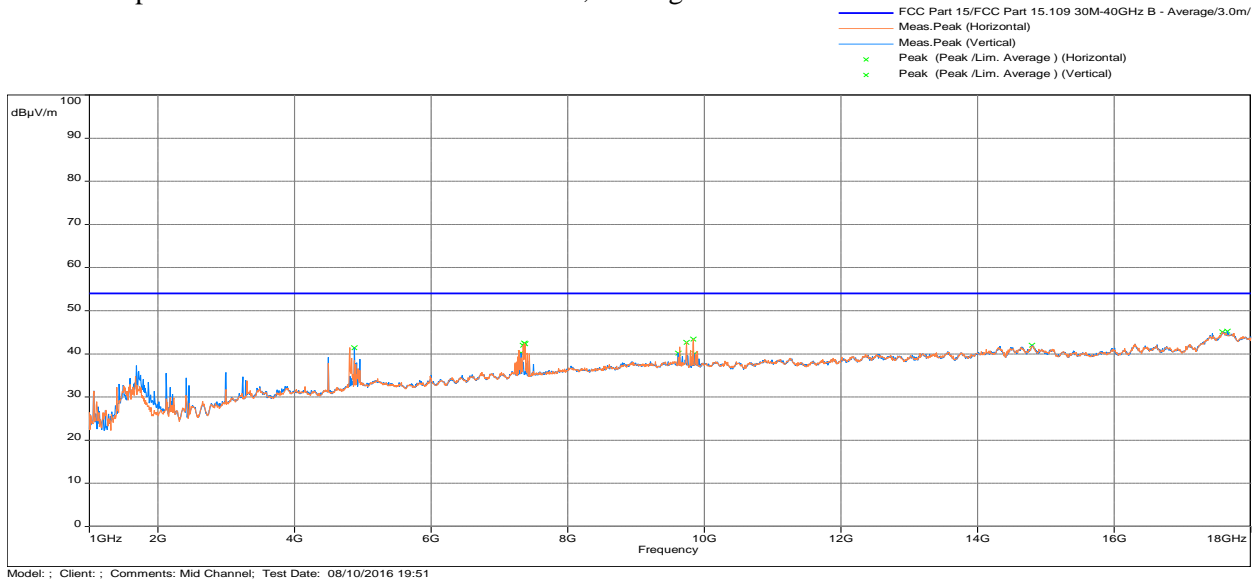



### Radiated Spurious Emissions 1000 - 18000 MHz, Peak Scan

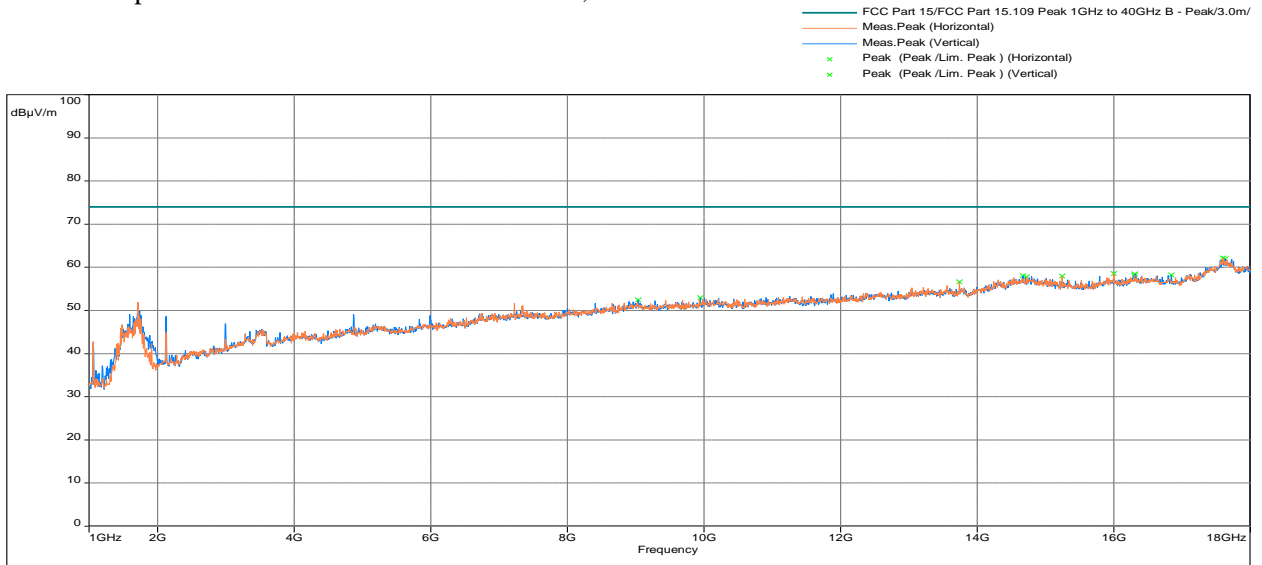



Test Results: 15.209 Radiated Spurious Emissions High Channel, Tx at 2480MHz

Radiated Spurious Emissions 30 MHz - 1000 MHz

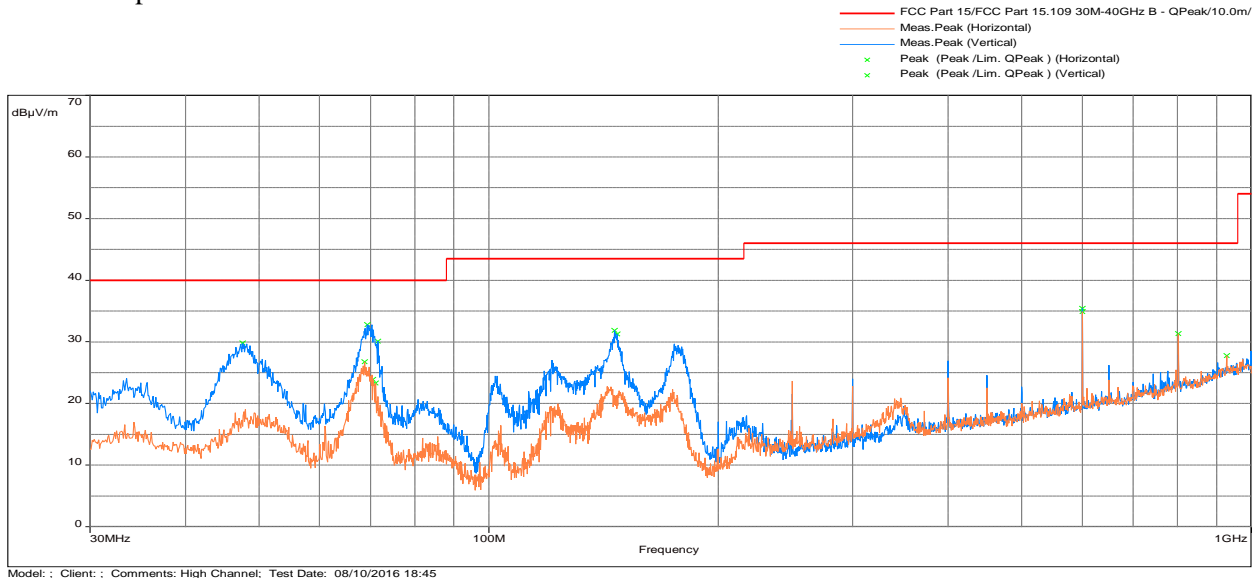

Radiated Spurious Emissions 1000 - 18000 MHz, Average Scan

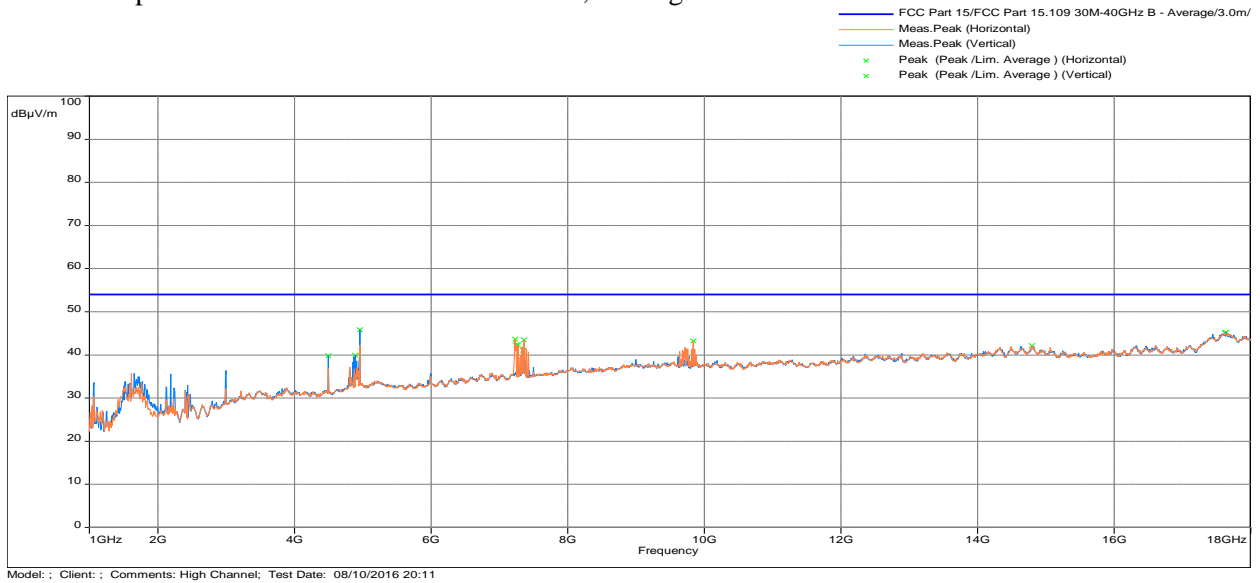



## Radiated Spurious Emissions 1000 - 18000 MHz, Peak Scan

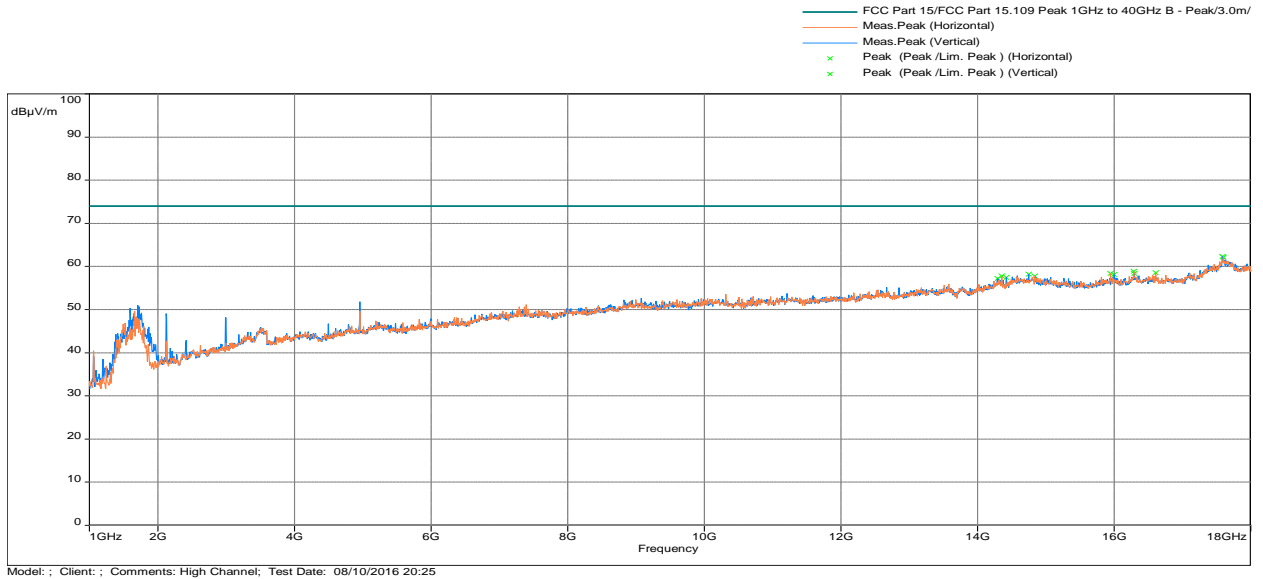

<b>Results</b>	<b>Complies</b>
----------------	-----------------

A.1.7 Test setup photographs

The following photographs show the testing configurations used.



4.5.5 Test setup photographs (Continued)

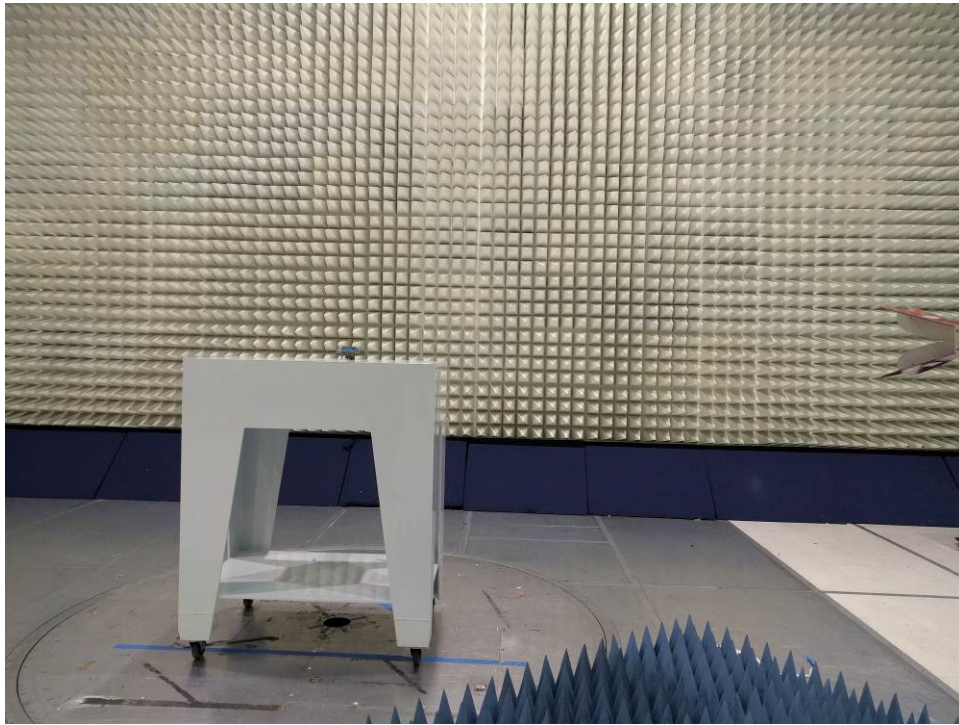

## A.2 Radiated Emissions

FCC Ref: 15.109, ICES 003

### A.2.1 Requirement

***Limits for Electromagnetic Radiated Emissions FCC Section 15.109(b), ICES 003\*, RSS GEN***

<b>Frequency (MHz)</b>	<b>Class A at 10m dB(<math>\mu</math>V/m)</b>	<b>Class B at 3m dB(<math>\mu</math>V/m)</b>
30-88	39	40.0
88-216	43.5	43.5
216-960	46.4	46.0
Above 960	49.5	54.0

\* According to FCC Part 15.109(g) an alternative to the radiated emission limits shown above, digital devices may be shown to comply with the limit of CISPR Pub. 22



### A.2.2 Procedures

Measurements are conducted with a quasi-peak detector instrument in the frequency range of 30 MHz to 1000 MHz and with the average detector instrument in the frequency range above 1000 MHz. The measuring receiver meets the requirements of Section One of CISPR 16 and the measuring antenna correlates to a balanced dipole.

Measurements of the radiated field are made with the antenna located at a distance of 10 meters from the EUT. If the field-strength measurements at 10m cannot be made because of high ambient noise level or for other reasons, measurements of Class B equipment may be made at a closer distance, for example 3m. An inverse proportionality factor of 20 dB per decade should be used to normalize the measured data to the specified distance for determining compliance.

The antenna is adjusted between 1m and 4m in height above the ground plane for maximum meter reading at each test frequency.

The antenna-to-EUT azimuth is varied during the measurement to find the maximum field-strength readings.

The antenna-to-EUT polarization (horizontal and vertical) is varied during the measurements to find the maximum field-strength readings.

The EUT, where intended for tabletop use, is placed on a table whose top is 0.8m above the ground plane. The table is constructed of non-conductive materials. Its dimensions are 1m by 1.5m, but may be extended for a larger EUT.

Floor standing EUT are placed on a horizontal metal ground plane and isolated from the ground plane by resting on an insulating material.

Equipment setup for radiated disturbance tests followed the guidelines of ANSI C63.4 and EN 55022.

### A.2.3 Test Results

Radiated emission measurements were performed from 30 MHz to 25 GHz. No Emissions were identified when scanned from 1-25 GHz. The data on the following pages list the significant emission frequencies, the limit and the margin of compliance.

<b>Date of Test:</b> August 10, 2016
--------------------------------------

Test Results: Radiated Emissions 30 MHz – 1000 MHz  
 Test Results: 15.109 Radiated Spurious Emissions Class A

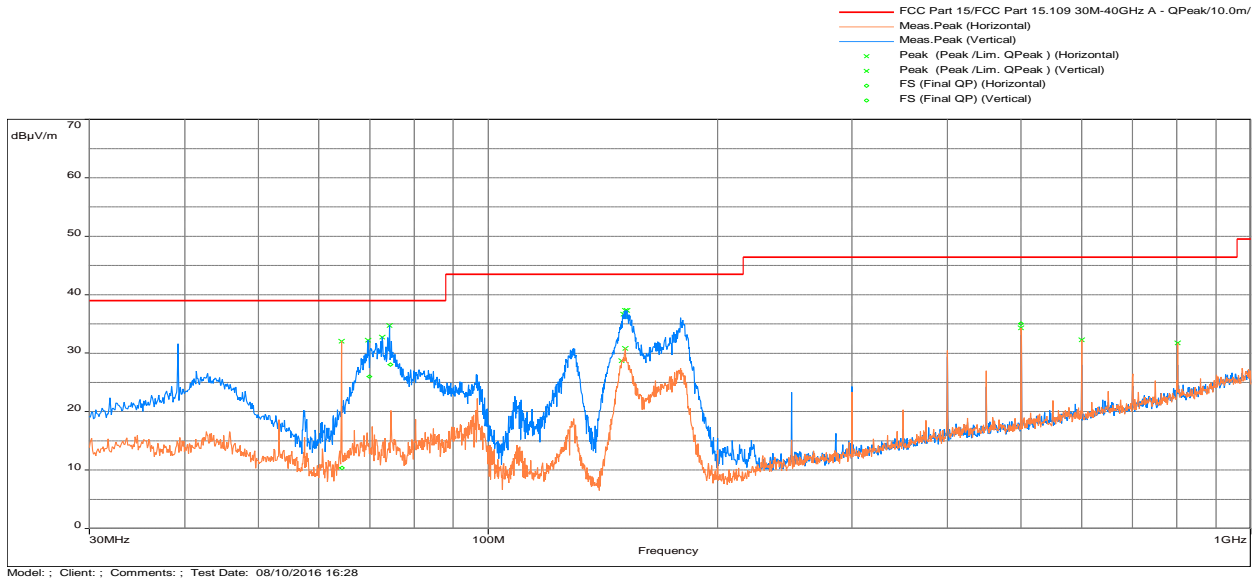

Frequency (MHz)	FS (dBµV/m)	Limit (dB(uV/m))	Margin (dB)	Azimuth (deg)	Height (m)	Polarity	RA (dBuV)	Correction (dB)
151.399	28.66	40	-11.34	203.25	3.84	Horizontal	51.55	-22.89
499.997	35.03	47	-11.97	9	1.53	Horizontal	46.93	-11.9
73.469	29.24	40	-10.76	225.5	1.84	Vertical	53.66	-24.42
128.746	30.15	40	-9.85	85.25	1	Vertical	49.46	-19.31
151.431	36.46	40	-3.54	298.5	1.08	Vertical	59.36	-22.89
179.031	33.51	40	-6.49	107.25	1	Vertical	55.05	-21.53

**Results** Complies by 3.54 dB

A.2.4 Test Configuration Photographs

The following photographs show the testing configurations used.



A.3 AC Line Conducted Emission  
FCC: 15.207, 15.107; RSS-GEN;

A.3.1 Requirement

Frequency Band MHz	FCC 15.207 Limit dB(μV)		FCC 15.107 Class A Limit dB(μV)	
	Quasi-Peak	Average	Quasi-Peak	Average
0.15-0.50	66 to 56 *	56 to 46 *	79	66
0.50-5.00	56	46	73	60
5.00-30.00	60	50	73	60

Note: \*Decreases linearly with the logarithm of the frequency. At the transition frequency the lower limit applies.

A.3.2 Procedure

Measurements are carried out using quasi-peak and average detector receivers in accordance with CISPR 16. An AMN is required to provide a defined impedance at high frequencies across the power feed at the point of measurement of terminal voltage and also to provide isolation of the circuit under test from the ambient noise on the power lines. An AMN as defined in CISPR 16 shall be used.

The EUT is located so that the distance between the boundary of the EUT and the closest surface of the AMN is 0.8m.

Where a flexible mains cord is provided by the manufacturer, this shall be 1m long or if in excess of 1m, the excess cable is folded back and forth as far as possible so as to form a bundle not exceeding 0.4m in length.

The EUT is arranged and connected with cables terminated in accordance with the product specification.

Conducted disturbance is measured between the phase lead and the reference ground, and between the neutral lead and the reference ground. Both measured values are reported.

The EUT, where intended for tabletop use, is placed on a table whose top is 0.8m above the ground plane. A vertical, metal reference plane is placed 0.4m from the EUT. The vertical metal reference-plane is at least 2m by 2m. The EUT shall be kept at least 0.8m from any other metal surface or other ground plane not being part of the EUT. The table is constructed of non-conductive materials. Its dimensions are 1m by 1.5m, but may be extended for larger EUT.

Floor standing EUT are placed on a horizontal metal ground plane and isolated from the ground plane by resting on an insulating material. The metal ground plane extends at least 0.5m beyond the boundaries of the EUT and has minimum dimensions of 2m by 2m.

Equipment setup for conducted disturbance tests followed the guidelines of ANSI C63.4 & ANSI C63.10.

<b>Date of Test:</b>	August 9, 2016
<b>Results</b>	<b>Complies</b>

A.3.3 Test Result

**AC Line Conducted Emission Data, EUT in transmission off (15.107)**

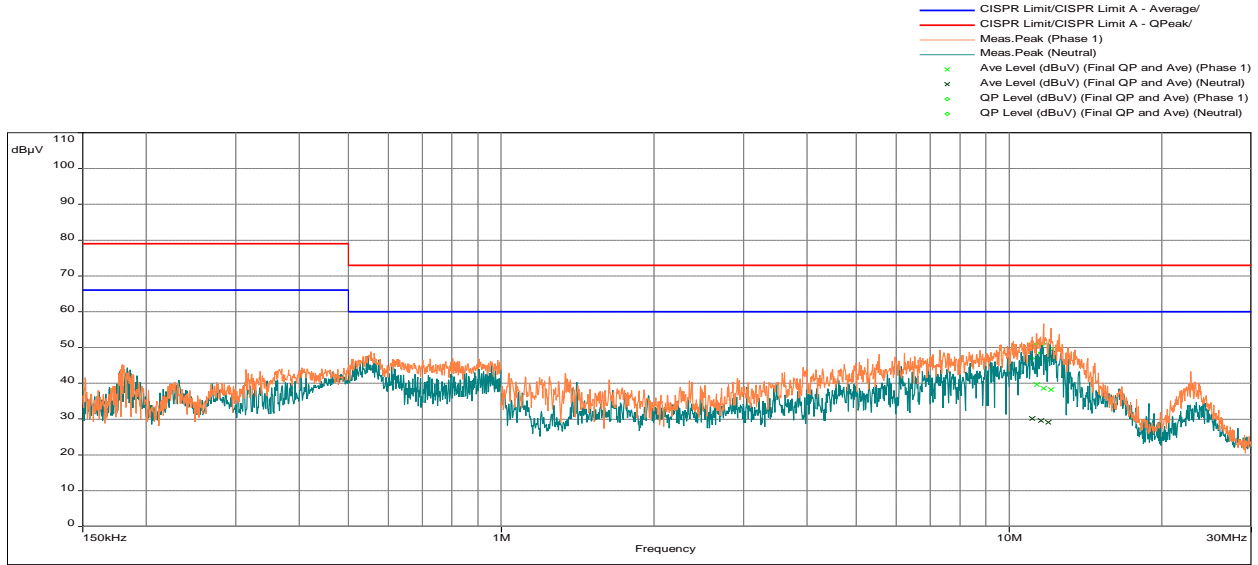

Model: ; Client: ; Comments: 120V 60Hz; Test Date: 08/09/2016 20:00

Frequency (MHz)	Ave Level (dBµV)	QP Level (dBµV)	Ave Limit (dBµV)	QP Limit (dBµV)	Ave Margin (dB)	QP Margin (dB)	Line	Correction (dB)
11.332	39.64	50.97	60	73	-20.36	-22.03	Phase 1	11.14
11.698	38.64	51.09	60	73	-21.36	-21.91	Phase 1	11.14
12.099	38.18	49.62	60	73	-21.82	-23.38	Phase 1	11.15
11.111	30.14	46.91	60	73	-29.86	-26.09	Neutral	11.14
11.544	29.58	48.46	60	73	-30.42	-24.54	Neutral	11.14
11.945	29.07	46.61	60	73	-30.93	-26.39	Neutral	11.15

**Results** Complies by 20.36 dB

4.7.3 Test Result (Continued)

**AC Line Conducted Emission Data, EUT in transmission on (15.207)**

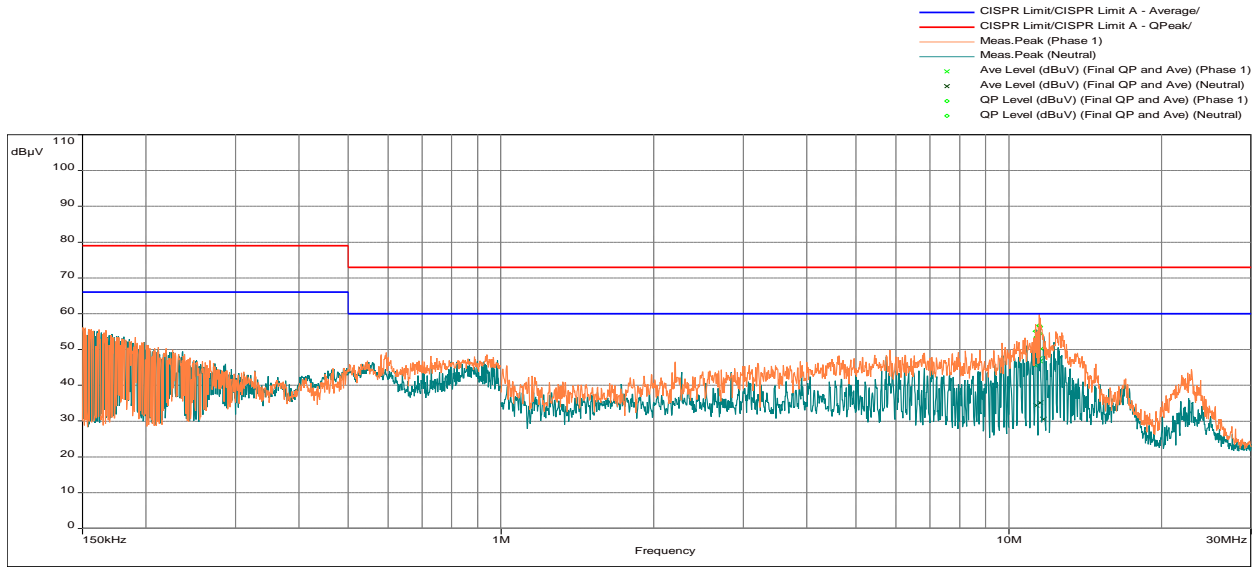

Model: ; Client: ; Comments: 120V 60Hz; Test Date: 08/09/2016 20:15

Frequency (MHz)	Ave Level (dBuV)	QP Level (dBuV)	Ave Limit (dBuV)	QP Limit (dBuV)	Ave Margin (dB)	QP Margin (dB)	Line	Correction (dB)
11.300	45.48	55.11	60	73	-14.52	-17.89	Phase 1	11.14
11.482	47.42	56.75	60	73	-12.58	-16.25	Phase 1	11.14
11.526	46.75	56.33	60	73	-13.25	-16.67	Phase 1	11.14
11.346	34.39	53.49	60	73	-25.61	-19.51	Neutral	11.14
11.526	35.16	54.47	60	73	-24.84	-18.53	Neutral	11.14
11.708	30.51	50.22	60	73	-29.49	-22.78	Neutral	11.14

**Results** Complies by 12.58 dB

#### A.3.4 Test Configuration Photographs

The following photographs show the testing configurations used.

