



MET Laboratories, Inc. *Safety Certification - EMI - Telecom Environmental Simulation*

914 WEST PATAPSCO AVENUE • BALTIMORE, MARYLAND 21230-3432 • PHONE (410) 354-3300 • FAX (410) 354-3313

33439 WESTERN AVENUE • UNION CITY, CALIFORNIA 94587 • PHONE (510) 489-6300 • FAX (510) 489-6372

3162 BELICK STREET • SANTA CLARA, CALIFORNIA 95054 • PHONE (408) 748-3585 • FAX (510) 489-6372

September 12, 2011

S&C Electric Company
1135 Atlantic Avenue
Alameda, CA 94501

Dear Prakash Ramadass,

Enclosed is the EMC Wireless test report for compliance testing of the S&C Electric Company, 1720 IntelliCom as tested to the requirements of Title 47 of the CFR, Ch. 1 (10-1-06 ed.), Title 47 of the CFR, Part 15, Subpart B, Industry Canada ICES-003 Issue 4 February 2004 for Unintentional Radiators and Part 15.407, Industry Canada RSS-210, Issue 8, December 2010 for Intentional Radiators.

Thank you for using the services of MET Laboratories, Inc. If you have any questions regarding these results or if MET can be of further service to you, please feel free to contact me.

Sincerely yours,
MET LABORATORIES, INC.

Jennifer Warnell
Documentation Department

Reference: (\S&C Electric Company\EMCS32814-FCC407 (UNII2))

Certificates and reports shall not be reproduced except in full, without the written permission of MET Laboratories, Inc.



MET Laboratories, Inc. *Safety Certification - EMI - Telecom Environmental Simulation*

914 WEST PATAPSCO AVENUE • BALTIMORE, MARYLAND 21230-3432 • PHONE (410) 354-3300 • FAX (410) 354-3313

33439 WESTERN AVENUE • UNION CITY, CALIFORNIA 94587 • PHONE (510) 489-6300 • FAX (510) 489-6372

3162 BELICK STREET • SANTA CLARA, CALIFORNIA 95054 • PHONE (408) 748-3585 • FAX (510) 489-6372

**Electromagnetic Compatibility Criteria
Test Report**

for the

**S&C Electric Company
Model 1720 IntelliCom**

Tested under

the Certification Rules
contained in

Title 47 of the CFR, Part 15, Subpart B and
ICES-003 Issue 4 February 2004
for Unintentional Radiators

and

Title 47 of the CFR, Part 15.407 and
Industry Canada RSS-210, Issue 8, December 2010
for Intentional Radiators

MET Report: EMCS32814-FCC407 (UNII2)

September 12, 2011

Prepared For:

**S&C Electric Company
1135 Atlantic Avenue
Alameda, CA 94501**

Prepared By:
MET Laboratories, Inc.
914 W. Patapsco Ave.
Baltimore, MD 21230

Electromagnetic Compatibility Criteria Test Report

for the

S&C Electric Company
Model 1720 IntelliCom

the Certification Rules
contained in
Title 47 of the CFR, Part 15, Subpart B and
ICES-003 Issue 4 February 2004
for Unintentional Radiators
and
Title 47 of the CFR, Part 15.407 and
Industry Canada RSS-210, Issue 8, December 2010
for Intentional Radiators



Minh Ly, Project Engineer
Electromagnetic Compatibility Lab



Jennifer Warnell
Documentation Department

Engineering Statement: The measurements shown in this report were made in accordance with the procedures indicated, and the emissions from this equipment were found to be within the limits applicable. I assume full responsibility for the accuracy and completeness of these measurements, and for the qualifications of all persons taking them. It is further stated that upon the basis of the measurements made, the equipment tested is capable of operation in accordance with the requirements of Parts 15B, 15.407, of the FCC Rules and ICES-003 and RSS-210 of the Industry Canada rules under normal use and maintenance.



Shawn McMillen, Wireless Manager
Electromagnetic Compatibility Lab

Report Status Sheet

Revision	Report Date	Reason for Revision
Ø	September 12, 2011	Initial Issue.

Table of Contents

I.	Executive Summary	1
	A. Purpose of Test	2
	B. Executive Summary	2
II.	Equipment Configuration	3
	A. Overview.....	4
	B. References.....	5
	C. Test Site	5
	D. Description of Test Sample.....	6
	E. Equipment Configuration.....	7
	F. Support Equipment	7
	G. Ports and Cabling Information.....	7
	H. Mode of Operation.....	8
	I. Method of Monitoring EUT Operation	8
	J. Modifications	8
	a) Modifications to EUT.....	8
	b) Modifications to Test Standard.....	8
	K. Disposition of EUT.....	8
III.	Electromagnetic Compatibility Criteria for Unintentional Radiators	9
	§ 15.107(a) Conducted Emissions Limits.....	10
	§ 15.109(a) Radiated Emissions Limits.....	13
IV.	Electromagnetic Compatibility Criteria for Intentional Radiators.....	17
	§ 15.203 Antenna Requirement.....	18
	§ 15.207 Conducted Emissions Limits	19
	§ 15.403(c) 26dB Bandwidth	22
	§ 15.407(a) RF Power Output	53
	§ 15.407(a)(1)(2) Peak Power Spectral Density	55
	§ 15.407(a)(6) Peak Excursion Ratio	57
	§ 15.407(b) Undesirable Emissions.....	73
	a) Radiated Harmonic Emissions.....	75
	b) Radiated Spurious Emissions	93
	c) EIRP	138
	d) Radiated Restricted Band	167
	§ 15.407(f) RF Exposure	181
	§ 15.407(g) Frequency Stability	182
	RSS-GEN Receiver Spurious Emissions.....	202
V.	DFS Requirements and Radar Waveform Description & Calibration	205
	A. DFS Requirements	206
	B. Radar Test Waveforms	207
	C. Radar Waveform Calibration	210
VI.	DFS Test Procedure and Test Results.....	217
	A. DFS Test Setup	218
	B. Description of Master Device	219
	C. UNII Detection Bandwidth.....	220
	D. Initial Channel Availability Check Time	224
	E. Radar Burst at the Beginning of Channel Availability Check Time.....	226
	F. Radar Burst at the End of Channel Availability Check Time	228
	G. In-Service Monitoring for Channel Move Time, Channel Closing Time, and Non-Occupancy.....	230
	H. Statistical Performance Check	234
VII.	Appendix A.....	247
VIII.	Test Equipment	294
IX.	Certification & User’s Manual Information.....	297
	A. Certification Information	298
	B. Label and User’s Manual Information	302
X.	ICES-003 Procedural & Labeling Requirements.....	304

List of Tables

Table 1. Executive Summary of EMC Part 15.407 Compliance Testing	2
Table 2. EUT Summary.....	4
Table 3. References	5
Table 4. Equipment Configuration	7
Table 5. Support Equipment.....	7
Table 6. Ports and Cabling Information	7
Table 7. Conducted Limits for Radio Frequency Devices calculated from FCC Part 15 Subsections 15.107(a) (b) and 15.207(a)	10
Table 8. Conducted Emissions - Voltage, AC Power, Test Results	11
Table 9. Radiated Emissions Limits calculated from FCC Part 15, §15.109 (a) (b)	13
Table 10. Radiated Emissions, Test Results, FCC Limits, 30 MHz – 1 GHz	14
Table 11. Radiated Emissions, Test Results, FCC Limits, 1GHz – 6GHz	15
Table 12. Radiated Emissions, Test Results, ICES-003 Limits, 30 MHz – 1 GHz	16
Table 13. Antenna Information	18
Table 14. Conducted Limits for Intentional Radiators from FCC Part 15 § 15.207(a)	19
Table 15. Conducted Emissions - Voltage, AC Power, Test Results	20
Table 16. Occupied Bandwidth, Port 1, Test Results	23
Table 17. Occupied Bandwidth, Port 2, Test Results	23
Table 18. Occupied Bandwidth, Port 3, Test Results	24
Table 19. Output Power Requirements from §15.407	53
Table 20. RF Power Output, Test Results, Summed Power	54
Table 21. Power Spectral Density, 802.11a, Test Results	56
Table 22. Power Spectral Density, 802.11n, Test Results, Port 1-3 & Summed.....	56
Table 23. Peak Excursion Ration, Test Results, Port 1	57
Table 24. Peak Excursion Ration, Test Results, Port 2	58
Table 25. Peak Excursion Ration, Test Results, Port 3	58
Table 26. Restricted Bands of Operation.....	73
Table 27. Radiated Harmonics, 802.11a, 9 dBi Omni, 5260 MHz.....	75
Table 28. Radiated Harmonics, 802.11a, 9 dBi Omni, 5320 MHz.....	75
Table 29. Radiated Harmonics, 802.11a, 9 dBi Omni, 5500 MHz.....	76
Table 30. Radiated Harmonics, 802.11a, 9 dBi Omni, 5580 MHz.....	76
Table 31. Radiated Harmonics, 802.11a, 9 dBi Omni, 5700 MHz.....	76
Table 32. Radiated Harmonics, 802.11a, 16 dBi Sector, 5260 MHz.....	77
Table 33. Radiated Harmonics, 802.11a, 16 dBi Sector, 5320 MHz.....	77
Table 34. Radiated Harmonics, 802.11a, 16 dBi Sector, 5500 MHz.....	78
Table 35. Radiated Harmonics, 802.11a, 16 dBi Sector, 5580 MHz.....	78
Table 36. Radiated Harmonics, 802.11a, 16 dBi Sector, 5700 MHz.....	78
Table 37. Radiated Harmonics, 802.11a, 19 dBi Panel, 5260 MHz.....	79
Table 38. Radiated Harmonics, 802.11a, 19 dBi Panel, 5320 MHz.....	79
Table 39. Radiated Harmonics, 802.11a, 19 dBi Panel, 5500 MHz.....	80
Table 40. Radiated Harmonics, 802.11a, 19 dBi Panel, 5580 MHz.....	80
Table 41. Radiated Harmonics, 802.11a, 19 dBi Panel, 5700 MHz.....	80
Table 42. Radiated Harmonics, 802.11n 20MHz, 9 dBi Omni, 5260 MHz	81
Table 43. Radiated Harmonics, 802.11n 20MHz, 9 dBi Omni, 5320 MHz	81
Table 44. Radiated Harmonics, 802.11n 20MHz, 9 dBi Omni, 5500 MHz	82
Table 45. Radiated Harmonics, 802.11n 20MHz, 9 dBi Omni, 5580 MHz	82
Table 46. Radiated Harmonics, 802.11n 20MHz, 9 dBi Omni, 5700 MHz	82
Table 47. Radiated Harmonics, 802.11n 20MHz, 16 dBi Sector, 5260 MHz	83
Table 48. Radiated Harmonics, 802.11n 20MHz, 16 dBi Sector, 5320 MHz	83
Table 49. Radiated Harmonics, 802.11n 20MHz, 16 dBi Sector, 5500 MHz	84
Table 50. Radiated Harmonics, 802.11n 20MHz, 16 dBi Sector, 5580 MHz	84
Table 51. Radiated Harmonics, 802.11n 20MHz, 16 dBi Sector, 5700 MHz	84
Table 52. Radiated Harmonics, 802.11n 20MHz, 19 dBi Panel, 5260 MHz.....	85
Table 53. Radiated Harmonics, 802.11n 20MHz, 19 dBi Panel, 5320 MHz.....	85
Table 54. Radiated Harmonics, 802.11n 20MHz, 19 dBi Panel, 5500 MHz.....	86

Table 55. Radiated Harmonics, 802.11n 20MHz, 19 dBi Panel, 5580 MHz.....	86
Table 56. Radiated Harmonics, 802.11n 20MHz, 19 dBi Panel, 5700 MHz.....	86
Table 57. Radiated Harmonics, 802.11n 40MHz, 9 dBi Omni, 5270 MHz	87
Table 58. Radiated Harmonics, 802.11n 40MHz, 9 dBi Omni, 5310 MHz	87
Table 59. Radiated Harmonics, 802.11n 40MHz, 9 dBi Omni, 5510 MHz	88
Table 60. Radiated Harmonics, 802.11n 40MHz, 9 dBi Omni, 5550 MHz	88
Table 61. Radiated Harmonics, 802.11n 40MHz, 9 dBi Omni, 5670 MHz	88
Table 62. Radiated Harmonics, 802.11n 40MHz, 16 dBi Sector, 5270 MHz	89
Table 63. Radiated Harmonics, 802.11n 40MHz, 16 dBi Sector, 5310 MHz	89
Table 64. Radiated Harmonics, 802.11n 40MHz, 16 dBi Sector, 5510 MHz	90
Table 65. Radiated Harmonics, 802.11n 40MHz, 16 dBi Sector, 5550 MHz	90
Table 66. Radiated Harmonics, 802.11n 40MHz, 16 dBi Sector, 5670 MHz	90
Table 67. Radiated Harmonics, 802.11n 40MHz, 19 dBi Panel, 5270 MHz.....	91
Table 68. Radiated Harmonics, 802.11n 40MHz, 19 dBi Panel, 5310 MHz.....	91
Table 69. Radiated Harmonics, 802.11n 40MHz, 19 dBi Panel, 5510 MHz.....	92
Table 70. Radiated Harmonics, 802.11n 40MHz, 19 dBi Panel, 5550 MHz.....	92
Table 71. Radiated Harmonics, 802.11n 40MHz, 19 dBi Panel, 5670 MHz.....	92
Table 72. EIRP Calculation, 9 dBi Omni	138
Table 73. EIRP Calculation, 16 dBi Sector	138
Table 74. EIRP Calculation, 19 dBi Panel	139
Table 75. Restricted Band Edge, Radiated, Test Results, 9 dBi Omni.....	167
Table 76. Restricted Band Edge, Radiated, Test Results, 16 dBi Sector.....	167
Table 77. Restricted Band Edge, Radiated, Test Results, 19 dBi Panel	168
Table 78. Spurious Emission Limits for Receivers	202
Table 79. UNII Detection Bandwidth, Test Results, 5580 MHz, 802.11a	221
Table 80. UNII Detection Bandwidth, Test Results, 5310 MHz, 802.11n 40MHz.....	222
Table 81. Statistical Performance Check – Radar Type 1, 5580 MHz, 802.11a	235
Table 82. Statistical Performance Check – Radar Type 2, 5580 MHz, 802.11a	236
Table 83. Statistical Performance Check – Radar Type 3, 5580 MHz, 802.11a	237
Table 84. Statistical Performance Check – Radar Type 4, 5580 MHz, 802.11a	238
Table 85. Statistical Performance Check – Radar Type 5, 5580 MHz, 802.11a	239
Table 86. Statistical Performance Check – Radar Type 6, 5580 MHz, 802.11a	240
Table 87. Statistical Performance Check – Radar Type 1, 5310 MHz, 802.11n 40MHz	241
Table 88. Statistical Performance Check – Radar Type 2, 5310 MHz, 802.11n 40MHz	242
Table 89. Statistical Performance Check – Radar Type 3, 5310 MHz, 802.11n 40MHz	243
Table 90. Statistical Performance Check – Radar Type 4, 5310 MHz, 802.11n 40MHz	244
Table 91. Statistical Performance Check – Radar Type 5, 5310 MHz, 802.11n 40MHz	245
Table 92. Statistical Performance Check – Radar Type 6, 5310 MHz, 802.11n 40MHz	246
Table 93. Test Equipment List	295
Table 94. DFS Test Equipment List.....	296

List of Figures

Figure 1. Block Diagram of Test Configuration.....	6
Figure 2. Occupied Bandwidth Test Setup.....	22
Figure 3. Peak Power Output Test Setup.....	53
Figure 4. Peak Power Spectral Density Test Setup.....	55
Figure 5. Long Pulse Radar Test Signal Waveform.....	209
Figure 6. DFS Radar Waveform Calibration Setup.....	210
Figure 7. Test Setup Diagram.....	218

List of Plots

Plot 1. Conducted Emission, Phase Line Plot	11
Plot 2. Conducted Emission, Neutral Line Plot.....	12
Plot 3. Radiated Emissions, Pre-Scan, FCC Limits, 30 MHz – 1 GHz	14
Plot 4. Radiated Emissions, Pre-Scan, FCC Limits, 1 GHz – 6 GHz.....	15
Plot 5. Radiated Emissions, Pre-Scan, ICES-003 Limits, 30 MHz – 1 GHz.....	16
Plot 6. §15.207 Conducted Emissions, Phase Line Plot, 1720 IntelliCom.....	20
Plot 7. §15.207 Conducted Emissions, Neutral Line Plot, 1720 IntelliCom	21
Plot 8. Occupied Bandwidth, Port 1, 802.11a, 5260 MHz	25
Plot 9. Occupied Bandwidth, Port 1, 802.11a, 5320 MHz	25
Plot 10. Occupied Bandwidth, Port 1, 802.11a, 5500 MHz	25
Plot 11. Occupied Bandwidth, Port 1, 802.11a, 5580 MHz	26
Plot 12. Occupied Bandwidth, Port 1, 802.11a, 5700 MHz	26
Plot 13. Occupied Bandwidth, Port 1, 802.11n 20MHz, 5260 MHz	27
Plot 14. Occupied Bandwidth, Port 1, 802.11n 20MHz, 5320 MHz	27
Plot 15. Occupied Bandwidth, Port 1, 802.11n 20MHz, 5500 MHz	27
Plot 16. Occupied Bandwidth, Port 1, 802.11n 20MHz, 5580 MHz	28
Plot 17. Occupied Bandwidth, Port 1, 802.11n 20MHz, 5700 MHz	28
Plot 18. Occupied Bandwidth, Port 1, 802.11n 40MHz, 5270 MHz	29
Plot 19. Occupied Bandwidth, Port 1, 802.11n 40MHz, 5310 MHz	29
Plot 20. Occupied Bandwidth, Port 1, 802.11n 40MHz, 5510 MHz	29
Plot 21. Occupied Bandwidth, Port 1, 802.11n 40MHz, 5550 MHz	30
Plot 22. Occupied Bandwidth, Port 1, 802.11n 40MHz, 5670 MHz	30
Plot 23. Occupied Bandwidth, Port 2, 802.11n 20MHz, 5260 MHz	31
Plot 24. Occupied Bandwidth, Port 2, 802.11n 20MHz, 5320 MHz	31
Plot 25. Occupied Bandwidth, Port 2, 802.11n 20MHz, 5500 MHz	31
Plot 26. Occupied Bandwidth, Port 2, 802.11n 20MHz, 5580 MHz	32
Plot 27. Occupied Bandwidth, Port 2, 802.11n 20MHz, 5700 MHz	32
Plot 28. Occupied Bandwidth, Port 2, 802.11n 40MHz, 5270 MHz	33
Plot 29. Occupied Bandwidth, Port 2, 802.11n 40MHz, 5310 MHz	33
Plot 30. Occupied Bandwidth, Port 2, 802.11n 40MHz, 5510 MHz	33
Plot 31. Occupied Bandwidth, Port 2, 802.11n 40MHz, 5550 MHz	34
Plot 32. Occupied Bandwidth, Port 2, 802.11n 40MHz, 5670 MHz	34
Plot 33. Occupied Bandwidth, Port 3, 802.11n 20MHz, 5260 MHz	35
Plot 34. Occupied Bandwidth, Port 3, 802.11n 20MHz, 5320 MHz	35
Plot 35. Occupied Bandwidth, Port 3, 802.11n 20MHz, 5500 MHz	35
Plot 36. Occupied Bandwidth, Port 3, 802.11n 20MHz, 5580 MHz	36
Plot 37. Occupied Bandwidth, Port 3, 802.11n 20MHz, 5700 MHz	36
Plot 38. Occupied Bandwidth, Port 3, 802.11n 40MHz, 5270 MHz	37
Plot 39. Occupied Bandwidth, Port 3, 802.11n 40MHz, 5310 MHz	37
Plot 40. Occupied Bandwidth, Port 3, 802.11n 40MHz, 5510 MHz	37
Plot 41. Occupied Bandwidth, Port 3, 802.11n 40MHz, 5550 MHz	38
Plot 42. Occupied Bandwidth, Port 3, 802.11n 40MHz, 5670 MHz	38
Plot 43. 99% Occupied Bandwidth, Port 1, 802.11a, 5260 MHz	39

Plot 44. 99% Occupied Bandwidth, Port 1, 802.11a, 5320 MHz	39
Plot 45. 99% Occupied Bandwidth, Port 1, 802.11a, 5500 MHz	39
Plot 46. 99% Occupied Bandwidth, Port 1, 802.11a, 5580 MHz	40
Plot 47. 99% Occupied Bandwidth, Port 1, 802.11a, 5700 MHz	40
Plot 48. 99% Occupied Bandwidth, Port 1, 802.11n 20MHz, 5260 MHz.....	41
Plot 49. 99% Occupied Bandwidth, Port 1, 802.11n 20MHz, 5320 MHz.....	41
Plot 50. 99% Occupied Bandwidth, Port 1, 802.11n 20MHz, 5500 MHz.....	41
Plot 51. 99% Occupied Bandwidth, Port 1, 802.11n 20MHz, 5580 MHz.....	42
Plot 52. 99% Occupied Bandwidth, Port 1, 802.11n 20MHz, 5700 MHz.....	42
Plot 53. 99% Occupied Bandwidth, Port 1, 802.11n 40MHz, 5270 MHz.....	43
Plot 54. 99% Occupied Bandwidth, Port 1, 802.11n 40MHz, 5310 MHz.....	43
Plot 55. 99% Occupied Bandwidth, Port 1, 802.11n 40MHz, 5510 MHz.....	43
Plot 56. 99% Occupied Bandwidth, Port 1, 802.11n 40MHz, 5550 MHz.....	44
Plot 57. 99% Occupied Bandwidth, Port 1, 802.11n 40MHz, 5670 MHz.....	44
Plot 58. 99% Occupied Bandwidth, Port 2, 802.11n 20MHz, 5260 MHz.....	45
Plot 59. 99% Occupied Bandwidth, Port 2, 802.11n 20MHz, 5320 MHz.....	45
Plot 60. 99% Occupied Bandwidth, Port 2, 802.11n 20MHz, 5500 MHz.....	45
Plot 61. 99% Occupied Bandwidth, Port 2, 802.11n 20MHz, 5580 MHz.....	46
Plot 62. 99% Occupied Bandwidth, Port 2, 802.11n 20MHz, 5700 MHz.....	46
Plot 63. 99% Occupied Bandwidth, Port 2, 802.11n 40MHz, 5270 MHz.....	47
Plot 64. 99% Occupied Bandwidth, Port 2, 802.11n 40MHz, 5310 MHz.....	47
Plot 65. 99% Occupied Bandwidth, Port 2, 802.11n 40MHz, 5510 MHz.....	47
Plot 66. 99% Occupied Bandwidth, Port 2, 802.11n 40MHz, 5550 MHz.....	48
Plot 67. 99% Occupied Bandwidth, Port 2, 802.11n 40MHz, 5670 MHz.....	48
Plot 68. 99% Occupied Bandwidth, Port 3, 802.11n 20MHz, 5260 MHz.....	49
Plot 69. 99% Occupied Bandwidth, Port 3, 802.11n 20MHz, 5320 MHz.....	49
Plot 70. 99% Occupied Bandwidth, Port 3, 802.11n 20MHz, 5500 MHz.....	49
Plot 71. 99% Occupied Bandwidth, Port 3, 802.11n 20MHz, 5580 MHz.....	50
Plot 72. 99% Occupied Bandwidth, Port 3, 802.11n 20MHz, 5700 MHz.....	50
Plot 73. 99% Occupied Bandwidth, Port 3, 802.11n 40MHz, 5270 MHz.....	51
Plot 74. 99% Occupied Bandwidth, Port 3, 802.11n 40MHz, 5310 MHz.....	51
Plot 75. 99% Occupied Bandwidth, Port 3, 802.11n 40MHz, 5510 MHz.....	51
Plot 76. 99% Occupied Bandwidth, Port 3, 802.11n 40MHz, 5550 MHz.....	52
Plot 77. 99% Occupied Bandwidth, Port 3, 802.11n 40MHz, 5670 MHz.....	52
Plot 78. Peak Excursion, Port 1, 802.11a, 5260 MHz	59
Plot 79. Peak Excursion, Port 1, 802.11a, 5320 MHz	59
Plot 80. Peak Excursion, Port 1, 802.11a, 5500 MHz	59
Plot 81. Peak Excursion, Port 1, 802.11a, 5580 MHz	60
Plot 82. Peak Excursion, Port 1, 802.11a, 5700 MHz	60
Plot 83. Peak Excursion, Port 1, 802.11n 20MHz, 5260 MHz.....	61
Plot 84. Peak Excursion, Port 1, 802.11n 20MHz, 5320 MHz.....	61
Plot 85. Peak Excursion, Port 1, 802.11n 20MHz, 5500 MHz.....	61
Plot 86. Peak Excursion, Port 1, 802.11n 20MHz, 5580 MHz.....	62
Plot 87. Peak Excursion, Port 1, 802.11n 20MHz, 5700 MHz.....	62
Plot 88. Peak Excursion, Port 1, 802.11n 40MHz, 5270 MHz.....	63
Plot 89. Peak Excursion, Port 1, 802.11n 40MHz, 5310 MHz.....	63
Plot 90. Peak Excursion, Port 1, 802.11n 40MHz, 5510 MHz.....	63
Plot 91. Peak Excursion, Port 1, 802.11n 40MHz, 5550 MHz.....	64
Plot 92. Peak Excursion Ratio, Port 1, 802.11n 40MHz, 5670 MHz	64
Plot 93. Peak Excursion, Port 2, 802.11n 20MHz, 5260 MHz.....	65
Plot 94. Peak Excursion, Port 2, 802.11n 20MHz, 5320 MHz.....	65
Plot 95. Peak Excursion, Port 2, 802.11n 20MHz, 5500 MHz.....	65
Plot 96. Peak Excursion, Port 2, 802.11n 20MHz, 5580 MHz.....	66
Plot 97. Peak Excursion Ratio, Port 2, 802.11n 20MHz, 5700 MHz	66
Plot 98. Peak Excursion, Port 2, 802.11n 40MHz, 5270 MHz.....	67
Plot 99. Peak Excursion, Port 2, 802.11n 40MHz, 5310 MHz.....	67
Plot 100. Peak Excursion, Port 2, 802.11n 40MHz, 5510 MHz.....	67
Plot 101. Peak Excursion, Port 2, 802.11n 40MHz, 5550 MHz.....	68

Plot 102. Peak Excursion, Port 2, 802.11n 40MHz, 5670 MHz.....	68
Plot 103. Peak Excursion, Port 3, 802.11n 20MHz, 5260 MHz.....	69
Plot 104. Peak Excursion, Port 3, 802.11n 20MHz, 5320 MHz.....	69
Plot 105. Peak Excursion, Port 3, 802.11n 20MHz, 5500 MHz.....	69
Plot 106. Peak Excursion, Port 3, 802.11n 20MHz, 5580 MHz.....	70
Plot 107. Peak Excursion Ratio, Port 3, 802.11n 20MHz, 5700 MHz.....	70
Plot 108. Peak Excursion, Port 3, 802.11n 40MHz, 5270 MHz.....	71
Plot 109. Peak Excursion, Port 3, 802.11n 40MHz, 5310 MHz.....	71
Plot 110. Peak Excursion, Port 3, 802.11n 40MHz, 5510 MHz.....	71
Plot 111. Peak Excursion, Port 3, 802.11n 40MHz, 5550 MHz.....	72
Plot 112. Peak Excursion, Port 3, 802.11n 40MHz, 5670 MHz.....	72
Plot 113. Radiated Spurious, 802.11a, 5260 MHz, 30 MHz – 1 GHz, 9 dBi Omni.....	93
Plot 114. Radiated Spurious, 802.11a, 5260 MHz, 1 GHz – 18 GHz, 9 dBi Omni.....	93
Plot 115. Radiated Spurious, 802.11a, 5320 MHz, 30 MHz – 1 GHz, 9 dBi Omni.....	94
Plot 116. Radiated Spurious, 802.11a, 5320 MHz, 1 GHz – 18 GHz, 9 dBi Omni.....	94
Plot 117. Radiated Spurious, 802.11a, 5500 MHz, 30 MHz – 1 GHz, 9 dBi Omni.....	95
Plot 118. Radiated Spurious, 802.11a, 5500 MHz, 1 GHz – 18 GHz, 9 dBi Omni.....	95
Plot 119. Radiated Spurious, 802.11a, 5580 MHz, 30 MHz – 1 GHz, 9 dBi Omni.....	96
Plot 120. Radiated Spurious, 802.11a, 5580 MHz, 1 GHz – 18 GHz, 9 dBi Omni.....	96
Plot 121. Radiated Spurious, 802.11a, 5700 MHz, 30 MHz – 1 GHz, 9 dBi Omni.....	97
Plot 122. Radiated Spurious, 802.11a, 5700 MHz, 1 GHz – 18 GHz, 9 dBi Omni.....	97
Plot 123. Radiated Spurious, 802.11a, 5260 MHz, 30 MHz – 1 GHz, 16 dBi Sector.....	98
Plot 124. Radiated Spurious, 802.11a, 5260 MHz, 1 GHz – 18 GHz, 16 dBi Sector.....	98
Plot 125. Radiated Spurious, 802.11a, 5320 MHz, 30 MHz – 1 GHz, 16 dBi Sector.....	99
Plot 126. Radiated Spurious, 802.11a, 5320 MHz, 1 GHz – 18 GHz, 16 dBi Sector.....	99
Plot 127. Radiated Spurious, 802.11a, 5500 MHz, 30 MHz – 1 GHz, 16 dBi Sector.....	100
Plot 128. Radiated Spurious, 802.11a, 5500 MHz, 1 GHz – 18 GHz, 16 dBi Sector.....	100
Plot 129. Radiated Spurious, 802.11a, 5580 MHz, 30 MHz – 1 GHz, 16 dBi Sector.....	101
Plot 130. Radiated Spurious, 802.11a, 5580 MHz, 1 GHz – 18 GHz, 16 dBi Sector.....	101
Plot 131. Radiated Spurious, 802.11a, 5700 MHz, 30 MHz – 1 GHz, 16 dBi Sector.....	102
Plot 132. Radiated Spurious, 802.11a, 5700 MHz, 1 GHz – 18 GHz, 16 dBi Sector.....	102
Plot 133. Radiated Spurious, 802.11a, 5260 MHz, 30 MHz – 1 GHz, 19 dBi Panel.....	103
Plot 134. Radiated Spurious, 802.11a, 5260 MHz, 1 GHz – 18 GHz, 19 dBi Panel.....	103
Plot 135. Radiated Spurious, 802.11a, 5320 MHz, 30 MHz – 1 GHz, 19 dBi Panel.....	104
Plot 136. Radiated Spurious, 802.11a, 5320 MHz, 1 GHz – 18 GHz, 19 dBi Panel.....	104
Plot 137. Radiated Spurious, 802.11a, 5500 MHz, 30 MHz – 1 GHz, 19 dBi Panel.....	105
Plot 138. Radiated Spurious, 802.11a, 5500 MHz, 1 GHz – 18 GHz, 19 dBi Panel.....	105
Plot 139. Radiated Spurious, 802.11a, 5580 MHz, 30 MHz – 1 GHz, 19 dBi Panel.....	106
Plot 140. Radiated Spurious, 802.11a, 5580 MHz, 1 GHz – 18 GHz, 19 dBi Panel.....	106
Plot 141. Radiated Spurious, 802.11a, 5700 MHz, 30 MHz – 1 GHz, 19 dBi Panel.....	107
Plot 142. Radiated Spurious, 802.11a, 5700 MHz, 1 GHz – 18 GHz, 19 dBi Panel.....	107
Plot 143. Radiated Spurious, 802.11n 20MHz, 5260 MHz, 30 MHz – 1 GHz, 9 dBi Omni.....	108
Plot 144. Radiated Spurious, 802.11n 20MHz, 5260 MHz, 1 GHz – 18 GHz, 9 dBi Omni.....	108
Plot 145. Radiated Spurious, 802.11n 20MHz, 5320 MHz, 30 MHz – 1 GHz, 9 dBi Omni.....	109
Plot 146. Radiated Spurious, 802.11n 20MHz, 5320 MHz, 1 GHz – 18 GHz, 9 dBi Omni.....	109
Plot 147. Radiated Spurious, 802.11n 20MHz, 5500 MHz, 30 MHz – 1 GHz, 9 dBi Omni.....	110
Plot 148. Radiated Spurious, 802.11n 20MHz, 5500 MHz, 1 GHz – 18 GHz, 9 dBi Omni.....	110
Plot 149. Radiated Spurious, 802.11n 20MHz, 5580 MHz, 30 MHz – 1 GHz, 9 dBi Omni.....	111
Plot 150. Radiated Spurious, 802.11n 20MHz, 5580 MHz, 1 GHz – 18 GHz, 9 dBi Omni.....	111
Plot 151. Radiated Spurious, 802.11n 20MHz, 5700 MHz, 30 MHz – 1 GHz, 9 dBi Omni.....	112
Plot 152. Radiated Spurious, 802.11n 20MHz, 5700 MHz, 1 GHz – 18 GHz, 9 dBi Omni.....	112
Plot 153. Radiated Spurious, 802.11n 20MHz, 5260 MHz, 30 MHz – 1 GHz, 16 dBi Sector.....	113
Plot 154. Radiated Spurious, 802.11n 20MHz, 5260 MHz, 1 GHz – 18 GHz, 16 dBi Sector.....	113
Plot 155. Radiated Spurious, 802.11n 20MHz, 5320 MHz, 30 MHz – 1 GHz, 16 dBi Sector.....	114
Plot 156. Radiated Spurious, 802.11n 20MHz, 5320 MHz, 1 GHz – 18 GHz, 16 dBi Sector.....	114
Plot 157. Radiated Spurious, 802.11n 20MHz, 5500 MHz, 30 MHz – 1 GHz, 16 dBi Sector.....	115
Plot 158. Radiated Spurious, 802.11n 20MHz, 5500 MHz, 1 GHz – 18 GHz, 16 dBi Sector.....	115
Plot 159. Radiated Spurious, 802.11n 20MHz, 5580 MHz, 30 MHz – 1 GHz, 16 dBi Sector.....	116

Plot 160. Radiated Spurious, 802.11n 20MHz, 5580 MHz, 1 GHz – 18 GHz, 16 dBi Sector	116
Plot 161. Radiated Spurious, 802.11n 20MHz, 5700 MHz, 30 MHz – 1 GHz, 16 dBi Sector.....	117
Plot 162. Radiated Spurious, 802.11n 20MHz, 5700 MHz, 1 GHz – 18 GHz, 16 dBi Sector	117
Plot 163. Radiated Spurious, 802.11n 20MHz, 5260 MHz, 30 MHz – 1 GHz, 19 dBi Panel	118
Plot 164. Radiated Spurious, 802.11n 20MHz, 5260 MHz, 1 GHz – 18 GHz, 19 dBi Panel.....	118
Plot 165. Radiated Spurious, 802.11n 20MHz, 5320 MHz, 30 MHz – 1 GHz, 19 dBi Panel	119
Plot 166. Radiated Spurious, 802.11n 20MHz, 5320 MHz, 1 GHz – 18 GHz, 19 dBi Panel.....	119
Plot 167. Radiated Spurious, 802.11n 20MHz, 5500 MHz, 30 MHz – 1 GHz, 19 dBi Panel	120
Plot 168. Radiated Spurious, 802.11n 20MHz, 5500 MHz, 1 GHz – 18 GHz, 19 dBi Panel.....	120
Plot 169. Radiated Spurious, 802.11n 20MHz, 5580 MHz, 30 MHz – 1 GHz, 19 dBi Panel	121
Plot 170. Radiated Spurious, 802.11n 20MHz, 5580 MHz, 1 GHz – 18 GHz, 19 dBi Panel.....	121
Plot 171. Radiated Spurious, 802.11n 20MHz, 5700 MHz, 30 MHz – 1 GHz, 19 dBi Panel	122
Plot 172. Radiated Spurious, 802.11n 20MHz, 5700 MHz, 1 GHz – 18 GHz, 19 dBi Panel.....	122
Plot 173. Radiated Spurious, 802.11n 40MHz, 5270 MHz, 30 MHz – 1 GHz, 9 dBi Omni.....	123
Plot 174. Radiated Spurious, 802.11n 40MHz, 5270 MHz, 1 GHz – 18 GHz, 9 dBi Omni	123
Plot 175. Radiated Spurious, 802.11n 40MHz, 5310 MHz, 30 MHz – 1 GHz, 9 dBi Omni.....	124
Plot 176. Radiated Spurious, 802.11n 40MHz, 5310 MHz, 1 GHz – 18 GHz, 9 dBi Omni	124
Plot 177. Radiated Spurious, 802.11n 40MHz, 5510 MHz, 30 MHz – 1 GHz, 9 dBi Omni.....	125
Plot 178. Radiated Spurious, 802.11n 40MHz, 5510 MHz, 1 GHz – 18 GHz, 9 dBi Omni	125
Plot 179. Radiated Spurious, 802.11n 40MHz, 5550 MHz, 30 MHz – 1 GHz, 9 dBi Omni.....	126
Plot 180. Radiated Spurious, 802.11n 40MHz, 5550 MHz, 1 GHz – 18 GHz, 9 dBi Omni.....	126
Plot 181. Radiated Spurious, 802.11n 40MHz, 5670 MHz, 30 MHz – 1 GHz, 9 dBi Omni.....	127
Plot 182. Radiated Spurious, 802.11n 40MHz, 5670 MHz, 1 GHz – 18 GHz, 9 dBi Omni	127
Plot 183. Radiated Spurious, 802.11n 40MHz, 5270 MHz, 30 MHz – 1 GHz, 16 dBi Sector.....	128
Plot 184. Radiated Spurious, 802.11n 40MHz, 5270 MHz, 1 GHz – 18 GHz, 16 dBi Sector	128
Plot 185. Radiated Spurious, 802.11n 40MHz, 5310 MHz, 30 MHz – 1 GHz, 16 dBi Sector.....	129
Plot 186. Radiated Spurious, 802.11n 40MHz, 5310 MHz, 1 GHz – 18 GHz, 16 dBi Sector	129
Plot 187. Radiated Spurious, 802.11n 40MHz, 5510 MHz, 30 MHz – 1 GHz, 16 dBi Sector.....	130
Plot 188. Radiated Spurious, 802.11n 40MHz, 5510 MHz, 1 GHz – 18 GHz, 16 dBi Sector	130
Plot 189. Radiated Spurious, 802.11n 40MHz, 5550 MHz, 30 MHz – 1 GHz, 16 dBi Sector.....	131
Plot 190. Radiated Spurious, 802.11n 40MHz, 5550 MHz, 1 GHz – 18 GHz, 16 dBi Sector	131
Plot 191. Radiated Spurious, 802.11n 40MHz, 5670 MHz, 30 MHz – 1 GHz, 16 dBi Sector.....	132
Plot 192. Radiated Spurious, 802.11n 40MHz, 5670 MHz, 1 GHz – 18 GHz, 16 dBi Sector	132
Plot 193. Radiated Spurious, 802.11n 40MHz, 5270 MHz, 30 MHz – 1 GHz, 19 dBi Panel	133
Plot 194. Radiated Spurious, 802.11n 40MHz, 5270 MHz, 1 GHz – 18 GHz, 19 dBi Panel.....	133
Plot 195. Radiated Spurious, 802.11n 40MHz, 5310 MHz, 30 MHz – 1 GHz, 19 dBi Panel	134
Plot 196. Radiated Spurious, 802.11n 40MHz, 5310 MHz, 1 GHz – 18 GHz, 19 dBi Panel.....	134
Plot 197. Radiated Spurious, 802.11n 40MHz, 5510 MHz, 30 MHz – 1 GHz, 19 dBi Panel	135
Plot 198. Radiated Spurious, 802.11n 40MHz, 5510 MHz, 1 GHz – 18 GHz, 19 dBi Panel.....	135
Plot 199. Radiated Spurious, 802.11n 40MHz, 5550 MHz, 30 MHz – 1 GHz, 19 dBi Panel	136
Plot 200. Radiated Spurious, 802.11n 40MHz, 5550 MHz, 1 GHz – 18 GHz, 19 dBi Panel.....	136
Plot 201. Radiated Spurious, 802.11n 40MHz, 5670 MHz, 30 MHz – 1 GHz, 19 dBi Panel	137
Plot 202. Radiated Spurious, 802.11n 40MHz, 5670 MHz, 1 GHz – 18 GHz, 19 dBi Panel.....	137
Plot 203. EIRP, Port 1, 802.11a, 5350 MHz Peak, 9 dBi Omni	140
Plot 204. EIRP, Port 1, 802.11a, 5350 MHz Over 1 MHz, 9 dBi Omni.....	140
Plot 205. EIRP, Port 1, 802.11a, 5470 MHz Peak, 9 dBi Omni	141
Plot 206. EIRP, Port 1, 802.11a, 5470 MHz Over 1 MHz, 9 dBi Omni.....	141
Plot 207. EIRP, Port 1, 802.11a, 5725 MHz Peak, 9 dBi Omni	142
Plot 208. EIRP, Port 1, 802.11a, 5725 MHz Over 1 MHz, 9 dBi Omni.....	142
Plot 209. EIRP, Port 1, 802.11a, 5350 MHz Peak, 16 dBi Sector.....	143
Plot 210. EIRP, Port 1, 802.11a, 5350 MHz Over 1 MHz, 16 dBi Sector.....	143
Plot 211. EIRP, Port 1, 802.11a, 5470 MHz Peak, 16 dBi Sector.....	144
Plot 212. EIRP, Port 1, 802.11a, 5470 MHz Over 1 MHz, 16 dBi Sector.....	144
Plot 213. EIRP, Port 1, 802.11a, 5725 MHz Peak, 16 dBi Sector.....	145
Plot 214. EIRP, Port 1, 802.11a, 5725 MHz Over 1 MHz, 16 dBi Sector.....	145
Plot 215. EIRP, Port 1, 802.11a, 5350 MHz Peak, 19 dBi Panel	146
Plot 216. EIRP, Port 1, 802.11a, 5350 MHz Over 1 MHz, 19 dBi Panel.....	146
Plot 217. EIRP, Port 1, 802.11a, 5470 MHz Peak, 19 dBi Panel	147

Plot 218. EIRP, Port 1, 802.11a, 5470 MHz Over 1 MHz, 19 dBi Panel.....	147
Plot 219. EIRP, Port 1, 802.11a, 5725 MHz Peak, 19 dBi Panel.....	148
Plot 220. EIRP, Port 1, 802.11a, 5725 MHz Over 1 MHz, 19 dBi Panel.....	148
Plot 221. EIRP, 802.11n 20MHz, 5350 MHz Peak, 9 dBi Omni.....	149
Plot 222. EIRP, 802.11n 20MHz, 5350 MHz Over 1 MHz, 9 dBi Omni.....	149
Plot 223. EIRP, 802.11n 20MHz, 5470 MHz Peak, 9 dBi Omni.....	150
Plot 224. EIRP, 802.11n 20MHz, 5470 MHz Over 1 MHz, 9 dBi Omni.....	150
Plot 225. EIRP, 802.11n 20MHz, 5725 MHz Peak, 9 dBi Omni.....	151
Plot 226. EIRP, 802.11n 20MHz, 5725 MHz Over 1 MHz, 9 dBi Omni.....	151
Plot 227. EIRP, 802.11n 20MHz, 5350 MHz Peak, 16 dBi Sector.....	152
Plot 228. EIRP, 802.11n 20MHz, 5350 MHz Over 1 MHz, 16 dBi Sector.....	152
Plot 229. EIRP, 802.11n 20MHz, 5470 MHz Peak, 16 dBi Sector.....	153
Plot 230. EIRP, 802.11n 20MHz, 5470 MHz Over 1 MHz, 16 dBi Sector.....	153
Plot 231. EIRP, 802.11n 20MHz, 5725 MHz Peak, 16 dBi Sector.....	154
Plot 232. EIRP, 802.11n 20MHz, 5725 MHz Over 1 MHz, 16 dBi Sector.....	154
Plot 233. EIRP, 802.11n 20MHz, 5350 MHz Peak, 19 dBi Panel.....	155
Plot 234. EIRP, 802.11n 20MHz, 5350 MHz Over 1 MHz, 19 dBi Panel.....	155
Plot 235. EIRP, 802.11n 20MHz, 5470 MHz Peak, 19 dBi Panel.....	156
Plot 236. EIRP, 802.11n 20MHz, 5470 MHz Over 1 MHz, 19 dBi Panel.....	156
Plot 237. EIRP, 802.11n 20MHz, 5725 MHz Peak, 19 dBi Panel.....	157
Plot 238. EIRP, 802.11n 20MHz, 5725 MHz Over 1 MHz, 19 dBi Panel.....	157
Plot 239. EIRP, 802.11n 40MHz, 5350 MHz Peak, 9 dBi Omni.....	158
Plot 240. EIRP, 802.11n 40MHz, 5350 MHz Over 1 MHz, 9 dBi Omni.....	158
Plot 241. EIRP, 802.11n 40MHz, 5470 MHz Peak, 9 dBi Omni.....	159
Plot 242. EIRP, 802.11n 40MHz, 5470 MHz Over 1 MHz, 9 dBi Omni.....	159
Plot 243. EIRP, 802.11n 40MHz, 5725 MHz Peak, 9 dBi Omni.....	160
Plot 244. EIRP, 802.11n 40MHz, 5725 MHz Over 1 MHz, 9 dBi Omni.....	160
Plot 245. EIRP, 802.11n 40MHz, 5350 MHz Peak, 16 dBi Sector.....	161
Plot 246. EIRP, 802.11n 40MHz, 5350 MHz Over 1 MHz, 16 dBi Sector.....	161
Plot 247. EIRP, 802.11n 40MHz, 5470 MHz Peak, 16 dBi Sector.....	162
Plot 248. EIRP, 802.11n 40MHz, 5470 MHz Over 1 MHz, 16 dBi Sector.....	162
Plot 249. EIRP, 802.11n 40MHz, 5725 MHz Peak, 16 dBi Sector.....	163
Plot 250. EIRP, 802.11n 40MHz, 5725 MHz Over 1 MHz, 16 dBi Sector.....	163
Plot 251. EIRP, 802.11n 40MHz, 5350 MHz Peak, 19 dBi Panel.....	164
Plot 252. EIRP, 802.11n 40MHz, 5350 MHz Over 1 MHz, 19 dBi Panel.....	164
Plot 253. EIRP, 802.11n 40MHz, 5470 MHz Peak, 19 dBi Panel.....	165
Plot 254. EIRP, 802.11n 40MHz, 5470 MHz Over 1 MHz, 19 dBi Panel.....	165
Plot 255. EIRP, 802.11n 40MHz, 5725 MHz Peak, 19 dBi Panel.....	166
Plot 256. EIRP, 802.11n 40MHz, 5725 MHz Over 1 MHz, 19 dBi Panel.....	166
Plot 257. Restricted Band, 802.11a, 5350 Average, 9 dBi Omni.....	169
Plot 258. Restricted Band, 802.11a, 5350 Peak, 9 dBi Omni.....	169
Plot 259. Restricted Band, 802.11a, 5460 Average, 9 dBi Omni.....	169
Plot 260. Restricted Band, 802.11a, 5460 Peak, 9 dBi Omni.....	170
Plot 261. Restricted Band, 802.11a, 5350 Average, 16 dBi Sector.....	170
Plot 262. Restricted Band, 802.11a, 5350 Peak, 16 dBi Sector.....	170
Plot 263. Restricted Band, 802.11a, 5460 Average, 16 dBi Sector.....	171
Plot 264. Restricted Band, 802.11a, 5460 Peak, 16 dBi Sector.....	171
Plot 265. Restricted Band, 802.11a, 5350 Average, 19 dBi Panel.....	171
Plot 266. Restricted Band, 802.11a, 5350 Peak, 19 dBi Panel.....	172
Plot 267. Restricted Band, 802.11a, 5460 Average, 19 dBi Panel.....	172
Plot 268. Restricted Band, 802.11a, 5460 Peak, 19 dBi Panel.....	172
Plot 269. Restricted Band, 802.11n 20MHz, 5350 Average, 9 dBi Omni.....	173
Plot 270. Restricted Band, 802.11n 20MHz, 5350 Peak, 9 dBi Omni.....	173
Plot 271. Restricted Band, 802.11n 20MHz, 5460 Average, 9 dBi Omni.....	173
Plot 272. Restricted Band, 802.11n 20MHz, 5460 Peak, 9 dBi Omni.....	174
Plot 273. Restricted Band, 802.11n 20MHz, 5350 Average, 16 dBi Sector.....	174
Plot 274. Restricted Band, 802.11n 20MHz, 5350 Peak, 16 dBi Sector.....	174
Plot 275. Restricted Band, 802.11n 20MHz, 5460 Average, 16 dBi Sector.....	175

Plot 276. Restricted Band, 802.11n 20MHz, 5460 Peak, 16 dBi Sector	175
Plot 277. Restricted Band, 802.11n 20MHz, 5350 Average, 19 dBi Panel	175
Plot 278. Restricted Band, 802.11n 20MHz, 5350 Peak, 19 dBi Panel	176
Plot 279. Restricted Band, 802.11n 20MHz, 5460 Average, 19 dBi Panel	176
Plot 280. Restricted Band, 802.11n 20MHz, 5460 Peak, 19 dBi Panel	176
Plot 281. Restricted Band, Combined, 802.11n 40MHz, 5350 Avg., 9 dBi Omni	177
Plot 282. Restricted Band, Combined, 802.11n 40MHz, 5350 Peak, 9 dBi Omni	177
Plot 283. Restricted Band, Combined, 802.11n 40MHz, 5460 Avg., 9 dBi Omni	177
Plot 284. Restricted Band, Combined, 802.11n 40MHz, 5460 Peak, 9 dBi Omni	178
Plot 285. Restricted Band, Combined, 802.11n 40MHz, 5350 Avg., 16 dBi Sector	178
Plot 286. Restricted Band, Combined, 802.11n 40MHz, 5350 Peak, 16 dBi Sector	178
Plot 287. Restricted Band, Combined, 802.11n 40MHz, 5460 Avg., 16 dBi Sector	179
Plot 288. Restricted Band, Combined, 802.11n 40MHz, 5460 Peak, 16 dBi Sector	179
Plot 289. Restricted Band, Combined, 802.11n 40MHz, 5350 Avg., 19 dBi Panel	179
Plot 290. Restricted Band, Combined, 802.11n 40MHz, 5350 Peak, 19 dBi Panel	180
Plot 291. Restricted Band, Combined, 802.11n 40MHz, 5460 Avg., 19 dBi Panel	180
Plot 292. Restricted Band, Combined, 802.11n 40MHz, 5460 Peak, 19 dBi Panel	180
Plot 293. Freq. Stability, Port 1, 5320 MHz @-40C Low Volt.	184
Plot 294. Freq. Stability, Port 1, 5320 MHz @-40C High Volt.	184
Plot 295. Freq. Stability, Port 1, 5500 MHz @-40C Low Volt.	185
Plot 296. Freq. Stability, Port 1, 5500 MHz @-40C High Volt.	185
Plot 297. Freq. Stability, Port 1, 5700 MHz @-40C Low Volt.	186
Plot 298. Freq. Stability, Port 1, 5700 MHz @-40C High Volt.	186
Plot 299. Freq. Stability, Port 1, 5320 MHz @+60C Low Volt.	187
Plot 300. Freq. Stability, Port 1, 5320 MHz @+60C High Volt.	187
Plot 301. Freq. Stability, Port 1, 5500 MHz @+60C Low Volt.	188
Plot 302. Freq. Stability, Port 1, 5500 MHz @+60C High Volt.	188
Plot 303. Freq. Stability, Port 1, 5700 MHz @+60C Low Volt.	189
Plot 304. Freq. Stability, Port 1, 5700 MHz @+60C High Volt.	189
Plot 305. Freq. Stability, Port 2, 5320 MHz @-40C Low Volt.	190
Plot 306. Freq. Stability, Port 2, 5320 MHz @-40C High Volt.	190
Plot 307. Freq. Stability, Port 2, 5500 MHz @-40C Low Volt.	191
Plot 308. Freq. Stability, Port 2, 5500 MHz @-40C High Volt.	191
Plot 309. Freq. Stability, Port 2, 5700 MHz @-40C Low Volt.	192
Plot 310. Freq. Stability, Port 2, 5700 MHz @-40C High Volt.	192
Plot 311. Freq. Stability, Port 2, 5320 MHz @+60C Low Volt.	193
Plot 312. Freq. Stability, Port 2, 5320 MHz @+60C High Volt.	193
Plot 313. Freq. Stability, Port 2, 5500 MHz @+60C Low Volt.	194
Plot 314. Freq. Stability, Port 2, 5500 MHz @+60C High Volt.	194
Plot 315. Freq. Stability, Port 2, 5700 MHz @+60C Low Volt.	195
Plot 316. Freq. Stability, Port 2, 5700 MHz @+60C High Volt.	195
Plot 317. Freq. Stability, Port 3, 5320 MHz @-40C Low Volt.	196
Plot 318. Freq. Stability, Port 3, 5320 MHz @-40C High Volt.	196
Plot 319. Freq. Stability, Port 3, 5500 MHz @-40C Low Volt.	197
Plot 320. Freq. Stability, Port 3, 5500 MHz @-40C High Volt.	197
Plot 321. Freq. Stability, Port 3, 5700 MHz @-40C Low Volt.	198
Plot 322. Freq. Stability, Port 3, 5700 MHz @-40C High Volt.	198
Plot 323. Freq. Stability, Port 3, 5320 MHz @+60C Low Volt.	199
Plot 324. Freq. Stability, Port 3, 5320 MHz @+60C High Volt.	199
Plot 325. Freq. Stability, Port 3, 5500 MHz @+60C Low Volt.	200
Plot 326. Freq. Stability, Port 3, 5500 MHz @+60C High Volt.	200
Plot 327. Freq. Stability, Port 3, 5700 MHz @+60C Low Volt.	201
Plot 328. Freq. Stability, Port 3, 5700 MHz @+60C High Volt.	201
Plot 329. Conducted Receiver Spurious Emissions, Port 1, 30 MHz – 1 GHz.	203
Plot 330. Conducted Receiver Spurious Emissions, Port 1, 1 GHz – 20 GHz	203
Plot 331. Conducted Receiver Spurious Emissions, Port 2, 30 MHz – 1 GHz.	203
Plot 332. Conducted Receiver Spurious Emissions, Port 2, 1 GHz – 20 GHz	204
Plot 333. Conducted Receiver Spurious Emissions, Port 3, 30 MHz – 1 GHz.	204

Plot 334. Conducted Receiver Spurious Emissions, Port 3, 1 GHz – 20 GHz	204
Plot 335. Occupied Bandwidth, 802.11a, 5580 MHz	223
Plot 336. Occupied Bandwidth, 802.11n 40MHz, 5310 MHz.....	223
Plot 337. Initial Channel Availability Check Time, 150 seconds, 5580 MHz, 802.11a	225
Plot 338. Radar Burst at the Beginning of CACT, 250 seconds, 5580 MHz, 802.11a	227
Plot 339. Radar Burst at the End of CACT, 250 seconds, 5580 MHz, 802.11a	229
Plot 340. Channel Move Time for Radar Type 1, 10 seconds, 5580 MHz, 802.11a	231
Plot 341. Channel Move Time for Radar Type 5, 22 seconds, 5580 MHz, 802.11a	231
Plot 342. Channel Closing Transmission Time, 200 milliseconds, 5580 MHz, 802.11a	232
Plot 343. Channel Closing Transmission Time, 260 milliseconds, 5580 MHz, 802.11a	232
Plot 344. Non-Occupancy Period, 30minutes, 5580 MHz, 802.11a.....	233

List of Terms and Abbreviations

AC	Alternating Current
ACF	Antenna Correction Factor
Cal	Calibration
<i>d</i>	Measurement Distance
dB	Decibels
dB μ A	Decibels above one microamp
dB μ V	Decibels above one microvolt
dB μ A/m	Decibels above one microamp per meter
dB μ V/m	Decibels above one microvolt per meter
DC	Direct Current
E	Electric Field
DSL	Digital Subscriber Line
ESD	Electrostatic Discharge
EUT	Equipment Under Test
<i>f</i>	Frequency
FCC	Federal Communications Commission
GRP	Ground Reference Plane
H	Magnetic Field
HCP	Horizontal Coupling Plane
Hz	Hertz
IEC	International Electrotechnical Commission
kHz	kilohertz
kPa	kilopascal
kV	kilovolt
LISN	Line Impedance Stabilization Network
MHz	Megahertz
μ H	microhenry
μ	microfarad
μ s	microseconds
PRF	Pulse Repetition Frequency
RF	Radio Frequency
RMS	Root-Mean-Square
TWT	Traveling Wave Tube
V/m	Volts per meter
VCP	Vertical Coupling Plane

I. Executive Summary

A. Purpose of Test

An EMC evaluation was performed to determine compliance of the S&C Electric Company 1720 IntelliCom, with the requirements of Part 15, §15.407. All references are to the most current version of Title 47 of the Code of Federal Regulations in effect. In accordance with §2.1033, the following data is presented in support of the Certification of the 1720 IntelliCom. S&C Electric Company should retain a copy of this document which should be kept on file for at least two years after the manufacturing of the 1720 IntelliCom, has been **permanently** discontinued.

B. Executive Summary

The following tests were conducted on a sample of the equipment for the purpose of demonstrating compliance with Part 15, §15.407, in accordance with S&C Electric Company, purchase order number 3035. All tests were conducted using measurement procedure ANSI C63.4-2003.

FCC Reference	Industry Canada Reference	Description	Results
15.107	ICES-003 Issue 4 February 2004	Conducted Emissions	Compliant
15.109		Radiated Emissions	Compliant
15.203	RSS-GEN 7.1.4	Antenna Requirements	Compliant
15.205/15.209	2.2	General Field Strength Limits (Restricted Bands and Radiated Emission Limits)	Compliant
15.207	RSS-GEN 7.2.2; RSS-210 2.2	AC Conducted Emissions 150KHz – 30MHz	Compliant
15.403 (c)	A8.2	26dB Occupied Bandwidth	Compliant
15.407 (a)(1), (2), (3)	A9.2(3)	Conducted Transmitter Output Power	Compliant
15.407 (a)(1), (2), (3), (5)	A9.2(3)	Power Spectral Density	Compliant
15.407 (a)(6)	A8.2	Peak Excursion	Compliant
15.407 (b)(1), (2), (5), (6)	A9.3(4)	Undesirable Emissions	Compliant
15.407(f)	RSS-GEN	RF Exposure	Compliant
15.407(g)	2.1	Frequency Stability	Compliant
15.407 (h)(1)	A9.4	Transmit Power Control (TPC) and Dynamic Frequency Selection (DFS)	Compliant
15.407 (h)(2)	A9.4	Channel Availability Check Time	Compliant
15.407 (h)(2)(ii)	A9.4	Channel Move Time and Channel Closing Time	Compliant
15.407 (h)(2)(iii)	A9.4	Non-Occupancy Period	Compliant
15.407 (h)(2)(iv)	A9.4	Radar Detection Function of Dynamic Frequency Selection (DFS)	Compliant

Table 1. Executive Summary of EMC Part 15.407 Compliance Testing

II. Equipment Configuration

A. Overview

MET Laboratories, Inc. was contracted by S&C Electric Company to perform testing on the 1720 IntelliCom, under S&C Electric Company's purchase order number 3035.

This document describes the test setups, test methods, required test equipment, and the test limit criteria used to perform compliance testing of the S&C Electric Company 1720 IntelliCom.

The results obtained relate only to the item(s) tested.

Model(s) Tested:	1720 IntelliCom		
Model(s) Covered:	1720 IntelliCom		
EUT Specifications:	Primary Power: 120 VDC		
	FCC ID: U3D-INTELLICOM IC: 5349C-INTELLICOM		
	Type of Modulations:	OFDM	
	Emission Designators:	802.11a – 16M9D7D 802.11n 20 MHz – 17M9D7D 802.11n 40 MHz – 36M9D7D	
	Equipment Code:	NII	
	Peak RF Output Power:	MHz	Power
		5260-5320	20.21dBm (0.105W)
		5270-5310	20.14dBm (0.103W)
		5500-5700	20.21dBm (0.105W)
	EUT Frequency Ranges:	5510-5690	20.00dBm (0.100W)
802.11a and 802.11n 20MHz BW 5260 MHz – 5320 MHz 5500 MHz – 5580 MHz 5660 MHz – 5700 MHz			
40MHz BW 5270 MHz – 5310 MHz 5510 MHz – 5550 MHz 5670MHz			
Analysis:	The results obtained relate only to the item(s) tested.		
Environmental Test Conditions:	Temperature: 15-35° C		
	Relative Humidity: 30-60%		
	Barometric Pressure: 860-1060 mbar		
Evaluated by:	Minh Ly		
Report Date(s):	September 12, 2011		

Table 2. EUT Summary

B. References

CFR 47, Part 15, Subpart B	Electromagnetic Compatibility: Criteria for Radio Frequency Devices
CFR 47, Part 15, Subpart E	Unlicensed National Information Infrastructure Devices (UNII)
RSS-210, Issue 8, December 2010	Low-power License-exempt Radiocommunications Devices (All Frequency Bands): Category I Equipment
ICES-003, Issue 4 February 2004	Electromagnetic Compatibility: Criteria for Radio Frequency Devices
ANSI C63.4:2003	Methods and Measurements of Radio-Noise Emissions from Low-Voltage Electrical And Electronic Equipment in the Range of 9 kHz to 40 GHz
ANSI/NCSL Z540-1-1994	Calibration Laboratories and Measuring and Test Equipment - General Requirements
ANSI/ISO/IEC 17025:2000	General Requirements for the Competence of Testing and Calibration Laboratories

Table 3. References

C. Test Site

All testing was performed at MET Laboratories, Inc., 3162 Belick Street, Santa Clara, CA 95054. All equipment used in making physical determinations is accurate and bears recent traceability to the National Institute of Standards and Technology.

Radiated Emissions measurements were performed in a 10 meter semi-anechoic chamber (equivalent to an Open Area Test Site). In accordance with §2.948(a)(3), a complete site description is contained at MET Laboratories.

D. Description of Test Sample

The S&C Electric Company 1720 IntelliCom, is a Dual Radio Wireless Mesh Node.

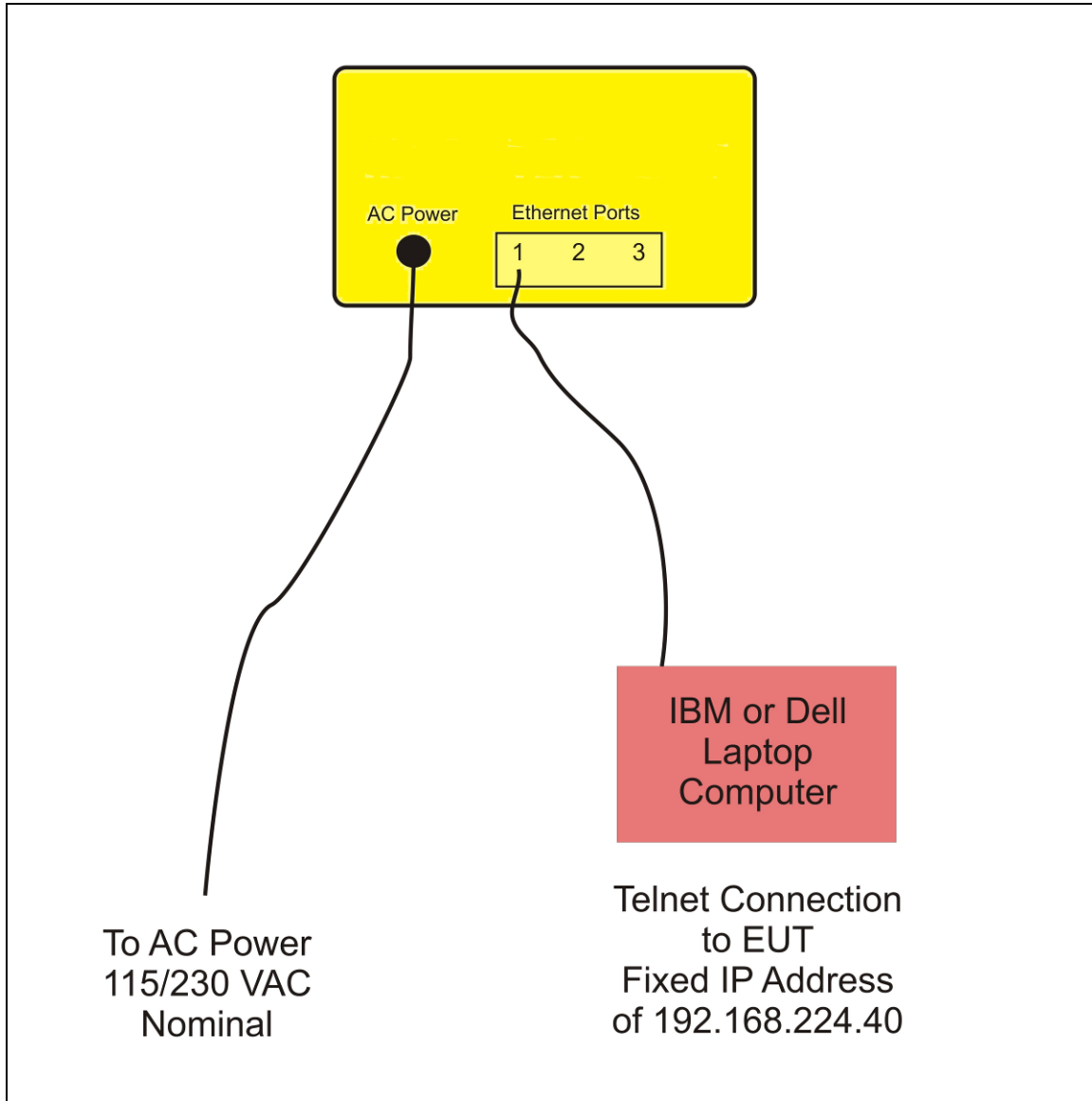

Figure 1. Block Diagram of Test Configuration

E. Equipment Configuration

The EUT was set up as outlined in Figure 1, Block Diagram of Test Setup. All cards, racks, etc., incorporated as part of the EUT is included in the following list.

Ref. ID	Slot #	Name / Description	Model Number	Serial Number	Rev. #
N/A	N/A	IntelliCom WAN 1720 Mesh Node	1720	N/A	1

Table 4. Equipment Configuration

F. Support Equipment

S&C Electric Company supplied support equipment necessary for the operation and testing of the 1720 IntelliCom. All support equipment supplied is listed in the following Support Equipment List.

Ref. ID	Name / Description	Manufacturer	Model Number
N/A	LAPTOP COMPUTER	IBM	T42
N/A	LAPTOP COMPUTER	DELL	S300

Table 5. Support Equipment

G. Ports and Cabling Information

Ref. ID	Port name on EUT	Cable Description or reason for no cable	Qty.	Length (m)	Shielded (Y/N)	Termination Box ID & Port Name
N/A	PORT 1	ETHERNET	1	18	N	N/A
N/A	PORT 2 – 3	NOT CONNECTED; ONLY 1 ETHERNET CONNECTION IS NECESSARY TO COMMUNICATE WITH EUT	N/A	N/A	N/A	N/A
N/A	AC POWER	3 PIN CIRCULAR CONNECTOR	1	5	N	N/A
N/A	USB	NOT USED; DISABLED	N/A	N/A	N/A	N/A

Table 6. Ports and Cabling Information

H. Mode of Operation

The UUT has the Atheros Radio Test (ART) software loaded. The UUT can be put into continuous TX or RX using ART. The Mesh Node has a default IP address of 192.168.224.150. An external computer can ping this address to verify the Ethernet PHY and processor are running.

I. Method of Monitoring EUT Operation

An external computer can ping this address to verify the Ethernet PHY and processor are running.

J. Modifications

- a) **Modifications to EUT**
No modifications were made to the EUT.
- b) **Modifications to Test Standard**
No modifications were made to the test standard.

K. Disposition of EUT

The test sample including all support equipment submitted to the Electro-Magnetic Compatibility Lab for testing was returned to S&C Electric Company upon completion of testing.

III. Electromagnetic Compatibility Criteria for Unintentional Radiators

Electromagnetic Compatibility Criteria

§ 15.107 Conducted Emissions Limits

Test Requirement(s): **15.107 (a)** Except for Class A digital devices, for equipment that is designed to be connected to the public utility (AC) power line, the radio frequency voltage that is conducted back onto the AC power line on any frequency or frequencies within the band 150 kHz to 30 MHz shall not exceed the limits in Table 7. Compliance with this provision shall be based on the measurement of the radio frequency voltage between each power line and ground at the power terminals.

15.107 (b) For a Class A digital device that is designed to be connected to the public utility (AC) power line, the radio frequency voltage that is conducted back onto the AC power line on any frequency or frequencies within the band 150 kHz to 30 MHz shall not exceed the limits in Table 7. Compliance with this provision shall be based on the measurement of the radio frequency voltage between each power line and ground at the power terminals. The lower limit applies at the band edges.

Frequency range (MHz)	Class A Conducted Limits (dB μ V)		*Class B Conducted Limits (dB μ V)	
	Quasi-Peak	Average	Quasi-Peak	Average
* 0.15- 0.45	79	66	66 - 56	56 - 46
0.45 - 0.5	79	66	56	46
0.5 - 30	73	60	60	50
Note 1 — The lower limit shall apply at the transition frequencies.				
Note 2 — The limit decreases linearly with the logarithm if the frequency in the range 0.15 MHz to 0.5 MHz.				
* -- Limits per Subsection 15.207(a).				

Table 7. Conducted Limits for Radio Frequency Devices calculated from FCC Part 15 Subsections 15.107(a) (b) and 15.207(a)

Test Results: The EUT was found compliant with the Class B requirement(s) of this section. Measured emissions were below applicable limits.

Test Engineer(s): Minh Ly

Test Date(s): 08/06/09

Conducted Emissions - Voltage, AC Power

Line	Freq (MHz)	QP Amplitude	QP Limit	Delta	Pass	Average Amplitude	Average Limit	Delta	Pass
Line	0.207	36.87	63.332	-26.462	Pass	32.02	53.332	-21.312	Pass
Line	9.56	36.79	60	-23.21	Pass	30.65	50	-19.35	Pass
Line	23.14	20.97	60	-39.03	Pass	15.998	50	-34.002	Pass
Neutral	0.207	34.76	63.332	-28.572	Pass	31.85	53.332	-21.482	Pass
Neutral	0.414	32.71	57.591	-24.881	Pass	31.52	47.591	-16.071	Pass
Neutral	9.562	37.77	60	-22.23	Pass	30.47	50	-19.53	Pass

Table 8. Conducted Emissions - Voltage, AC Power, Test Results

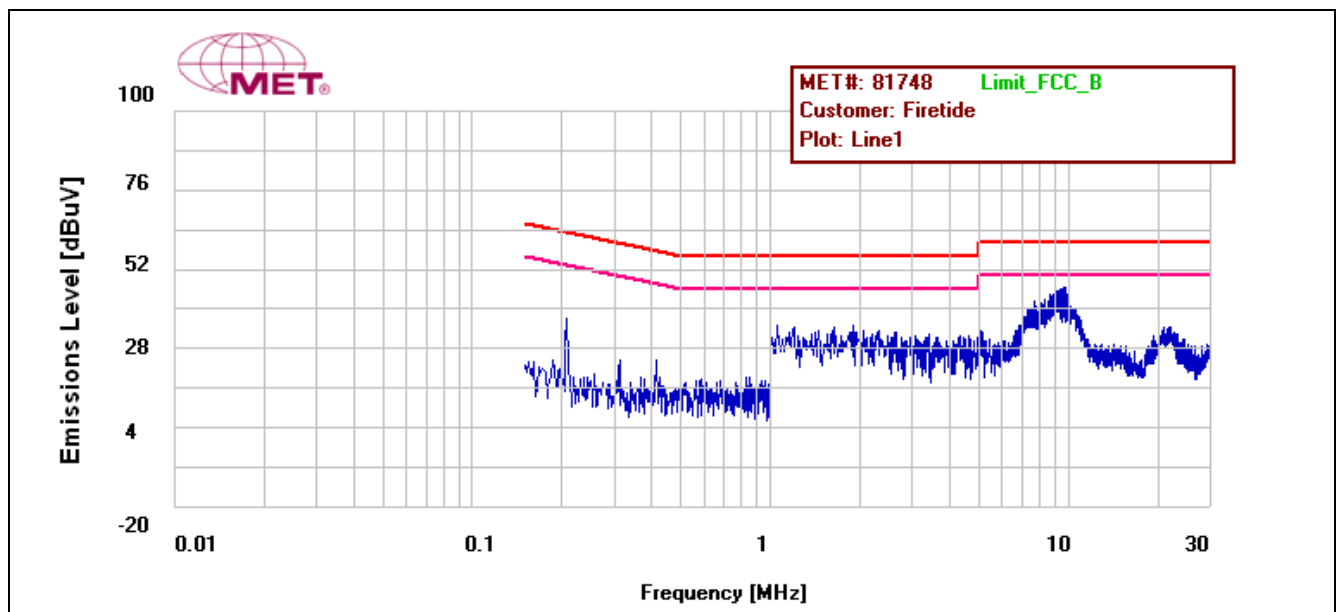

Plot 1. Conducted Emission, Phase Line Plot

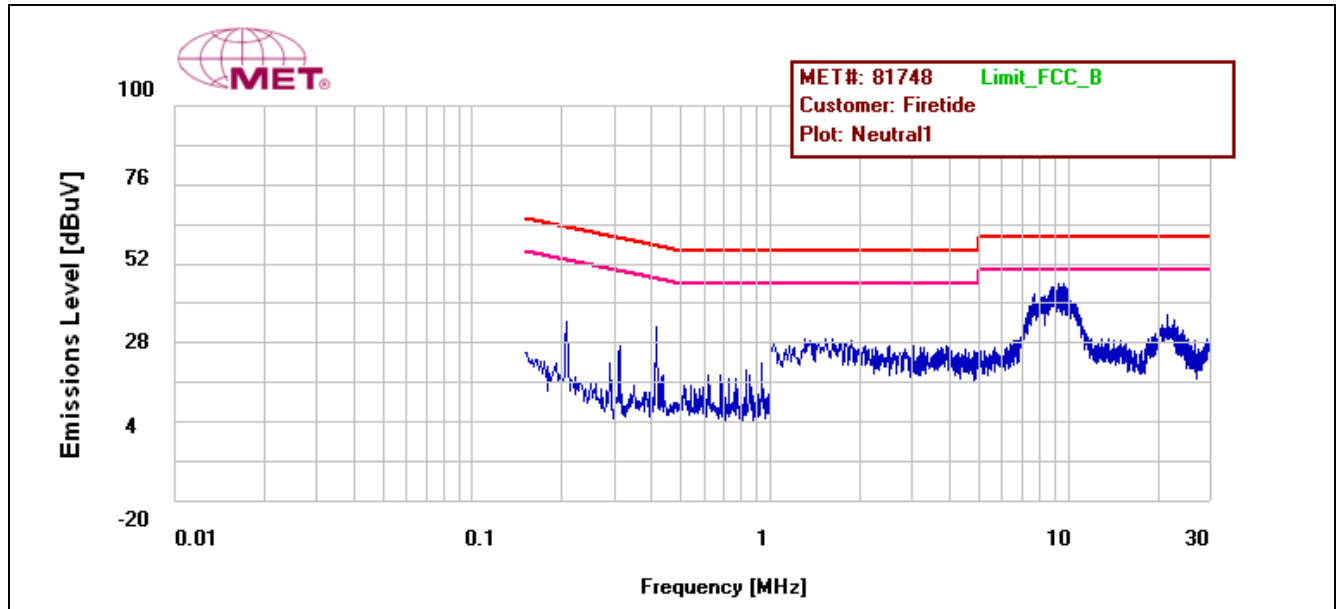

Plot 2. Conducted Emission, Neutral Line Plot

Radiated Emission Limits

§ 15.109 Radiated Emissions Limits

Test Requirement(s): **15.109 (a)** Except for Class A digital devices, the field strength of radiated emissions from unintentional radiators at a distance of 3 meters shall not exceed the Class B limits expressed in Table 9.

15.109 (b) The field strength of radiated emissions from a Class A digital device, as determined at a distance of 10 meters, shall not exceed the Class A limits expressed in Table 9.

Frequency (MHz)	Field Strength (dB μ V/m)	
	§15.109 (b), Class A Limit (dB μ V) @ 10m	§15.109 (a), Class B Limit (dB μ V) @ 3m
30 - 88	39.00	40.00
88 - 216	43.50	43.50
216 - 960	46.40	46.00
Above 960	49.50	54.00

Table 9. Radiated Emissions Limits calculated from FCC Part 15, §15.109 (a) (b)

Test Procedures: The EUT was placed on a 0.8m-high wooden table inside a semi-anechoic chamber. The method of testing and test conditions of ANSI C63.4 were used. An antenna was located 3 m from the EUT on an adjustable mast. A pre-scan was first performed in order to find prominent radiated emissions. For final emissions measurements at each frequency of interest, the EUT was rotated and the antenna height was varied between 1 m and 4 m in order to maximize the emission. Measurements in both horizontal and vertical polarities were made and the data was recorded. Unless otherwise specified, measurements were made using a quasi-peak detector with a 120 kHz bandwidth.

Test Results: The EUT was found to comply with the Class A requirement(s) of this section. Measured emissions were below applicable limits.

Test Engineer(s): Minh Ly

Test Date(s): 08/10/09

Radiated Emissions Limits Test Results, Class A

Frequency (MHz)	Antenna Polarity	EUT Azimuth (Degrees)	Antenna Height (cm)	Uncorrected Amplitude (dBuV)	ACF (dB/m)	Pre Amp Gain (dB)	CBL (dB)	DCF (dB)	Corrected Amplitude (dBuV/m)	Limit (dBuV/m)	Margin (dB)
45.84	V	278	100	26.74	9.164	0	1.644	-10.46	27.088	39	-11.912
100	V	0	100	20.3	12.7	0	2.47	-10.46	25.01	43.5	-18.49
100	H	237	190	21.32	11.1	0	2.47	-10.46	24.43	43.5	-19.07
157.52	H	106	202	29.59	10.898	0	3.178	-10.46	33.206	43.5	-10.294
157.6	V	213	100	28.96	11.292	0	3.178	-10.46	32.97	43.5	-10.53
332.48	H	206	109	20.96	14.75	0	4.64	-10.46	29.89	46.4	-16.51

Table 10. Radiated Emissions, Test Results, FCC Limits, 30 MHz – 1 GHz

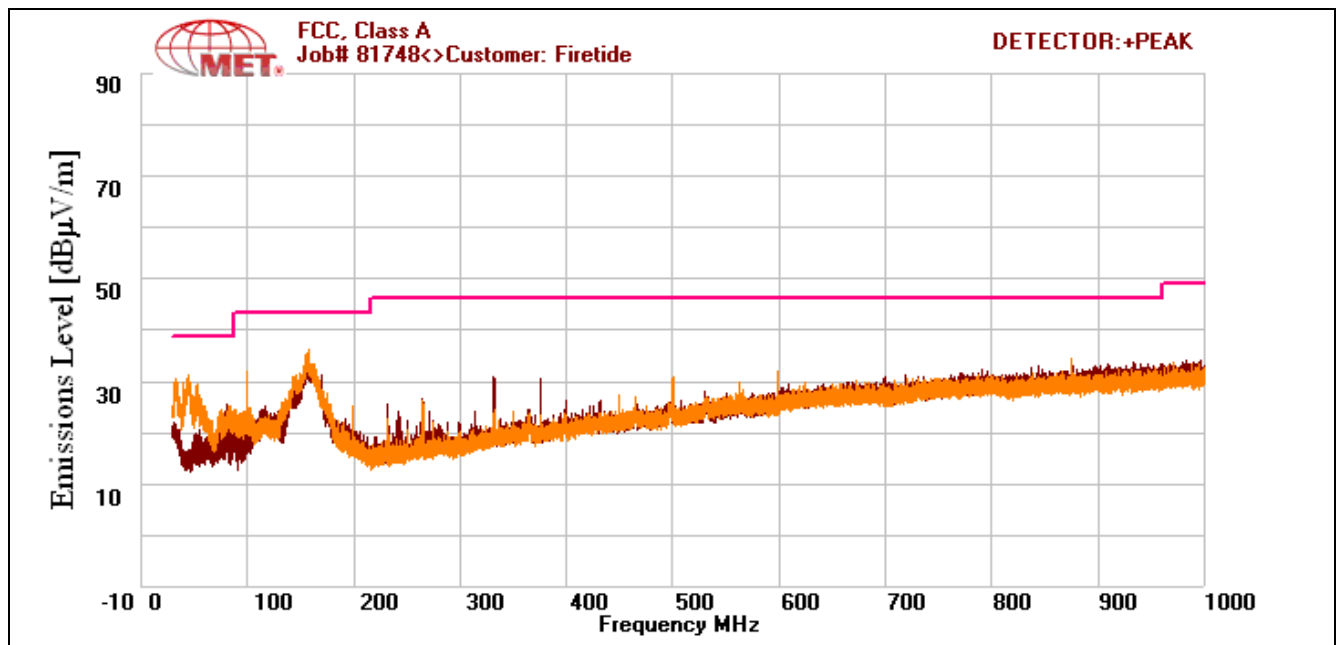

Plot 3. Radiated Emissions, Pre-Scan, FCC Limits, 30 MHz – 1 GHz

Frequency (MHz)	Antenna Polarity	EUT Azimuth (Degrees)	Antenna Height (cm)	Uncorrected Amplitude (dBuV)	ACF (dB/m)	Pre Amp Gain (dB)	CBL (dB)	DCF (dB)	Corrected Amplitude (dBuV/m)	Limit (dBuV/m)	Margin (dB)
1332	V	360	100	54.58	-1.641	35.149	1.726	-10.46	9.056	49.5	-40.444
1500	V	326	100	52.75	-1.848	34.894	1.82	-10.46	7.368	49.5	-42.132
4000	H	125	100	46.9	3.795	34.456	3.35	-10.46	9.129	49.5	-40.371
6000	V	0	100	44.09	8.972	34.372	4.61	-10.46	12.84	49.5	-36.66
6000	H	0	100	43.72	8.972	34.372	4.61	-10.46	12.47	49.5	-37.03

Table 11. Radiated Emissions, Test Results, FCC Limits, 1GHz – 6GHz

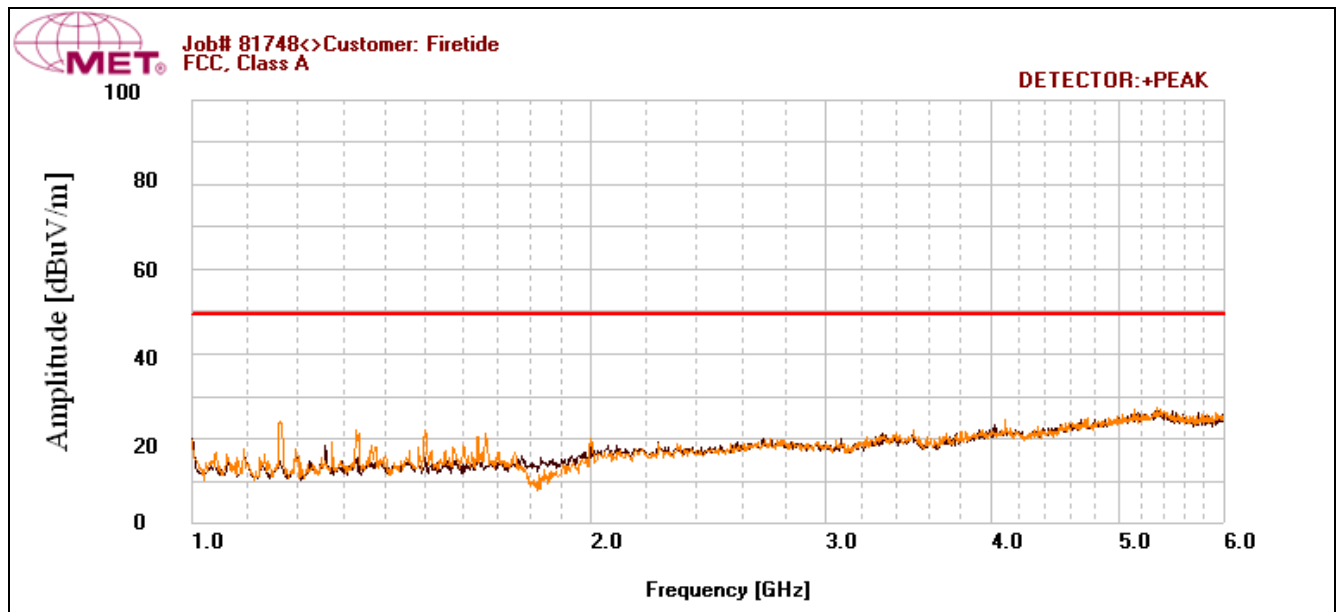

Plot 4. Radiated Emissions, Pre-Scan, FCC Limits, 1 GHz – 6 GHz

Frequency (MHz)	Antenna Polarity	EUT Azimuth (Degrees)	Antenna Height (cm)	Uncorrected Amplitude (dBuV)	ACF (dB/m)	Pre Amp Gain (dB)	CBL (dB)	DCF (dB)	Corrected Amplitude (dBuV/m)	Limit (dBuV/m)	Margin (dB)
45.84	V	278	100	26.74	9.164	0	1.644	-10.46	27.088	40	-12.912
100	V	0	100	20.3	12.7	0	2.47	-10.46	25.01	40	-14.99
157.6	V	213	100	28.96	11.292	0	3.178	-10.46	32.97	40	-7.03
100	H	237	190	21.32	11.1	0	2.47	-10.46	24.43	40	-15.57
157.52	H	106	202	29.59	10.898	0	3.178	-10.46	33.206	40	-6.794
332.48	H	206	109	20.96	14.75	0	4.64	-10.46	29.89	47	-17.11

Table 12. Radiated Emissions, Test Results, ICES-003 Limits, 30 MHz – 1 GHz

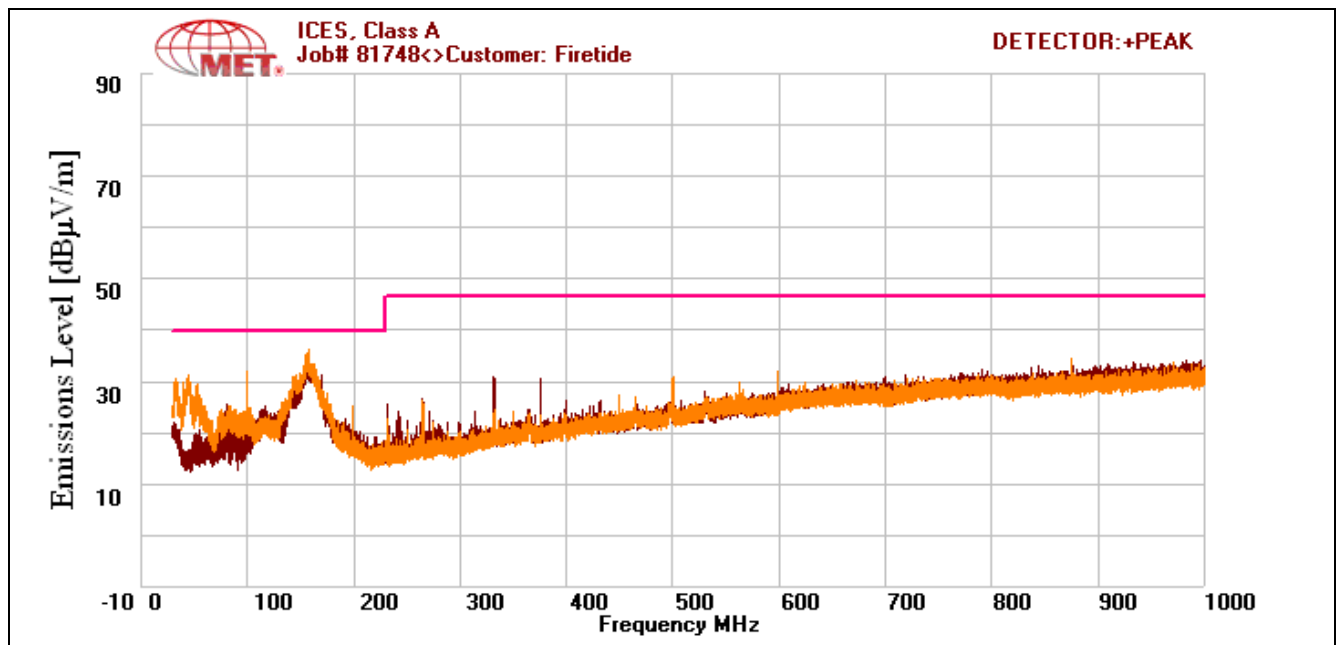

Plot 5. Radiated Emissions, Pre-Scan, ICES-003 Limits, 30 MHz – 1 GHz

IV. Electromagnetic Compatibility Criteria for Intentional Radiators

Electromagnetic Compatibility Criteria for Intentional Radiators

§ 15.203 Antenna Requirement

Test Requirement: § 15.203: An intentional radiator shall be designed to ensure that no antenna other than that furnished by the responsible party shall be used with the device. The use of a permanently attached antenna or of an antenna that uses a unique coupling to the intentional radiator shall be considered sufficient to comply with the provisions of this section. The manufacturer may design the unit so that a broken antenna can be replaced by the user, but the use of a standard antenna jack or electrical connector is prohibited.

The structure and application of the EUT were analyzed to determine compliance with Section 15.203 of the Rules. Section 15.203 states that the subject device must meet at least one of the following criteria:

- a.) Antenna must be permanently attached to the unit.
- b.) Antenna must use a unique type of connector to attach to the EUT.
- c.) Unit must be professionally installed. Installer shall be responsible for verifying that the correct antenna is employed with the unit.

Results: The EUT as tested is compliant the criteria of §15.203. The unit will be professionally installed.

Gain/Type	Model	Manufacturer
5dBi Omni (5GHz)	C812-510012-A	Wha Yu
9dBi Omni (5GHz)	MA-W055-MIMONHFT9	MARS ANTENNAS & RF Systems LTD
16dBi Sector (5GHz)	MA-WD55-MIMOFT16	MARS ANTENNAS & RF Systems LTD
19dBi Panel (5GHz)	MA-WA55-MIMO	MARS ANTENNAS & RF Systems LTD

Table 13. Antenna Information

Test Engineer(s): Minh Ly

Test Date(s): 09/02/09

Electromagnetic Compatibility Criteria for Intentional Radiators

§ 15.207 Conducted Emissions Limits

Test Requirement(s): § 15.207 (a): For an intentional radiator that is designed to be connected to the public utility (AC) power line, the radio frequency voltage that is conducted back onto the AC power line on any frequency or frequencies, within the band 150 kHz to 30MHz, shall not exceed the limits in the following table, as measured using a 50 μ H/50 Ω line impedance stabilization network (LISN). Compliance with the provisions of this paragraph shall be based on the measurement of the radio frequency voltage between each power line and ground at the power terminal. The lower limit applies at the boundary between the frequency ranges.

Frequency range (MHz)	§ 15.207(a), Conducted Limit (dB μ V)	
	Quasi-Peak	Average
* 0.15- 0.45	66 - 56	56 - 46
0.45 - 0.5	56	46
0.5 - 30	60	50

Table 14. Conducted Limits for Intentional Radiators from FCC Part 15 § 15.207(a)

Test Procedure: The EUT was placed on a 0.8 m-high wooden table inside a semi-anechoic chamber. The EUT was situated such that the back of the EUT was 0.4 m from one wall of the vertical ground plane, and the remaining sides of the EUT were no closer than 0.8 m from any other conductive surface. The EUT was powered from a 50 Ω /50 μ H Line Impedance Stabilization Network (LISN). The EMC receiver scanned the frequency range from 150 kHz to 30 MHz. Conducted Emissions measurements were made in accordance with *ANSI C63.4-1992 "Methods and Measurements of Radio-Noise Emissions from Low-Voltage Electrical and Electronic Equipment in the Range of 9kHz to 40 GHz"*. The measurements were performed over the frequency range of 0.15 MHz to 30 MHz using a 50 Ω /50 μ H LISN as the input transducer to an EMC/field intensity meter.

Test Results: The EUT was found to comply with the requirement(s) of this section. Measured emissions were below applicable limits.

Test Engineer(s): Minh Ly

Test Date(s): 08/17/09

Conducted Emissions - Voltage, AC Power

Line	Freq (MHz)	QP Amplitude	QP Limit	Delta	Pass	Average Amplitude	Average Limit	Delta	Pass
Line	0.206	38.73	63.372	-24.642	Pass	33.83	53.372	-19.542	Pass
Line	0.76	21.03	56	-34.97	Pass	16.023	46	-29.977	Pass
Line	9.45	37.95	60	-22.05	Pass	31.47	50	-18.53	Pass
Neutral	0.207	36.5	63.332	-26.832	Pass	33.9	53.332	-19.432	Pass
Neutral	0.414	33.77	57.591	-23.821	Pass	32.7	47.591	-14.891	Pass
Neutral	9.117	38.87	60	-21.13	Pass	32.33	50	-17.67	Pass

Table 15. Conducted Emissions - Voltage, AC Power, Test Results

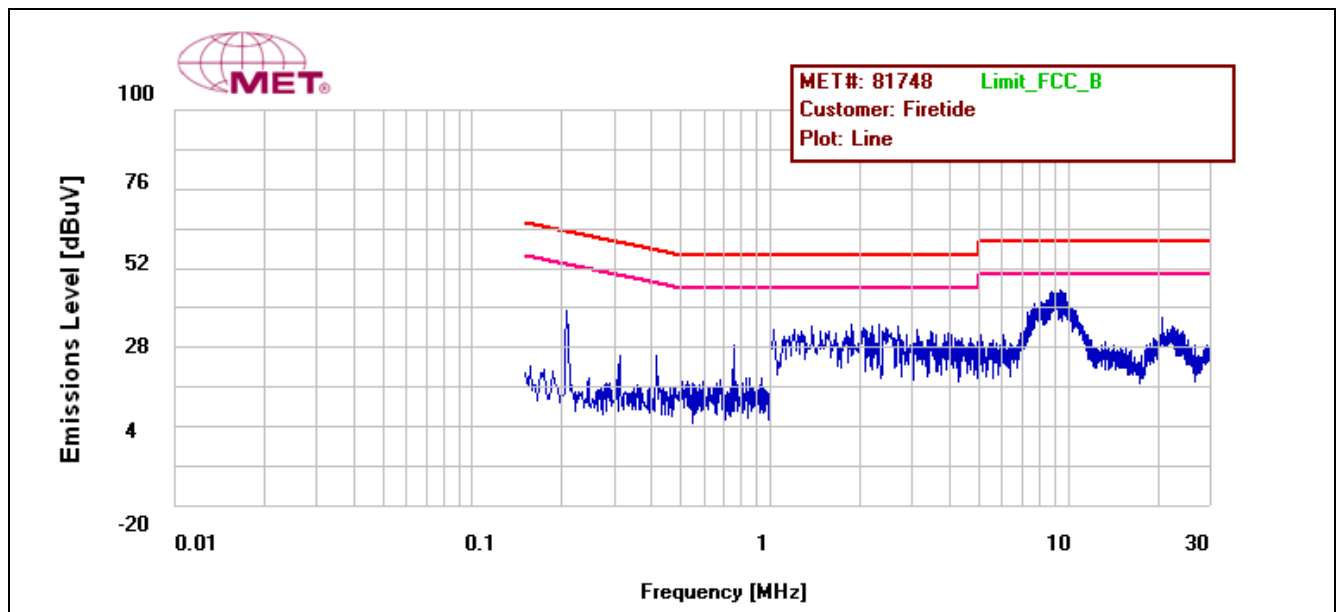

Plot 6. §15.207 Conducted Emissions, Phase Line Plot, 1720 IntelliCom

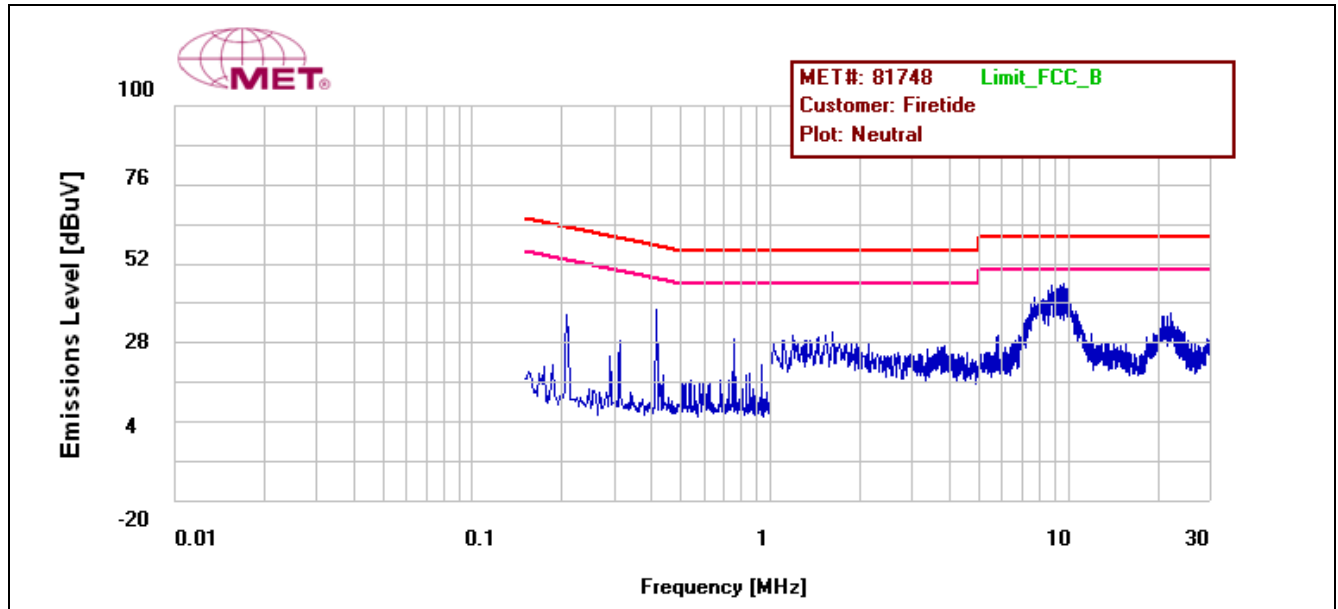

Plot 7. §15.207 Conducted Emissions, Neutral Line Plot, 1720 IntelliCom

Electromagnetic Compatibility Criteria for Intentional Radiators

§ 15.403(c) 26dB Bandwidth

Test Requirements:	§ 15.403 (c): Operation under the provisions of this section is limited to frequency hopping and digitally modulated intentional radiators that comply with the following provisions:
Test Procedure:	The transmitter was set to the mid channel at the highest output power and connected to the spectrum analyzer through an attenuator. The bandwidth of the fundamental frequency was measured with the spectrum analyzer using a RBW approximately equal to 1% of the total emission bandwidth, VBW > RBW. The 26 dB Bandwidth was measured and recorded. The measurements were repeated at the low and high channels.
Test Results	Equipment complies with § 15.407 (c). The 26 dB Bandwidth was determined from the plots on the following pages.
Test Engineer(s):	Minh Ly
Test Date(s):	07/28/09 – 08/11/09

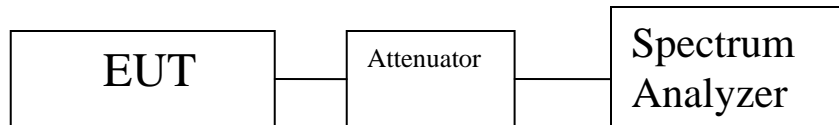

Figure 2. Occupied Bandwidth Test Setup

Occupied Bandwidth, Port 1			
Mode	Frequency (MHz)	Measured 26 dB Bandwidth (MHz)	99 % Bandwidth (MHz)
802.11a	5260	16.6051	16.2574
	5320	16.5974	16.4561
	5500	16.8858	16.2905
	5580	16.5369	16.4007
	5700	16.5889	16.3513
802.11n 20MHz	5260	17.8775	17.6328
	5320	17.7002	17.5481
	5500	17.7966	17.6993
	5580	17.6172	17.4919
	5700	17.7173	17.3338
802.11n 40MHz	5270	36.9057	36.7638
	5310	36.9001	36.6566
	5510	36.6398	36.4100
	5550	36.5579	36.5839
	5670	36.6412	36.6333

Table 16. Occupied Bandwidth, Port 1, Test Results

Occupied Bandwidth, Port 2			
Mode	Frequency (MHz)	Measured 26 dB Bandwidth (MHz)	99 % Bandwidth (MHz)
802.11n 20MHz	5260	17.7306	17.5789
	5320	17.7836	17.6254
	5500	17.8179	17.5414
	5580	17.5533	17.6765
	5700	17.6525	17.5882
802.11n 40MHz	5270	36.8372	36.6803
	5310	36.7184	36.2819
	5510	36.8367	36.5567
	5550	36.7273	36.4103
	5670	36.7982	36.7017

Table 17. Occupied Bandwidth, Port 2, Test Results

Occupied Bandwidth, Port 3			
Mode	Frequency (MHz)	Measured 26 dB Bandwidth (MHz)	99 % Bandwidth (MHz)
802.11n 20MHz	5260	17.8378	17.6291
	5320	17.7333	17.5672
	5500	17.7594	17.5506
	5580	17.6137	17.5337
	5700	17.8288	17.5724
802.11n 40MHz	5270	36.8721	36.2576
	5310	36.8101	36.8722
	5510	37.0056	36.8653
	5550	36.5107	36.6691
	5670	36.9159	36.4767

Table 18. Occupied Bandwidth, Port 3, Test Results

Occupied Bandwidth, Port 1

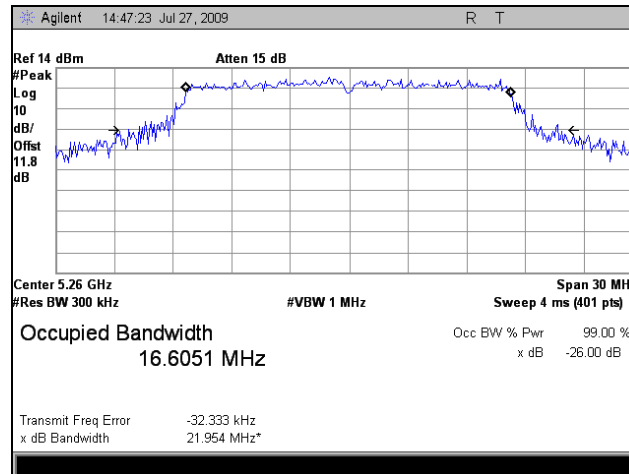

Plot 8. Occupied Bandwidth, Port 1, 802.11a, 5260 MHz

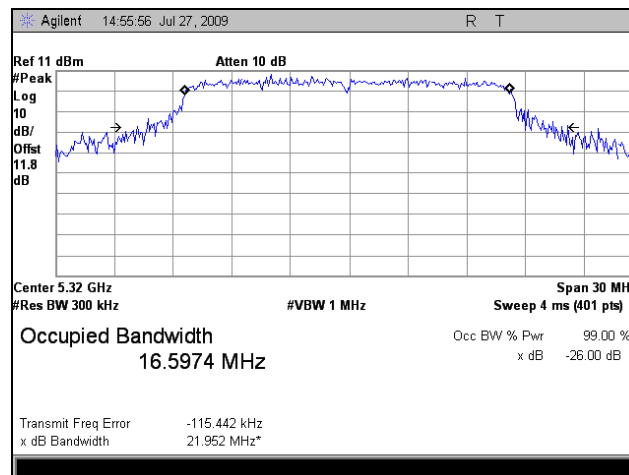

Plot 9. Occupied Bandwidth, Port 1, 802.11a, 5320 MHz

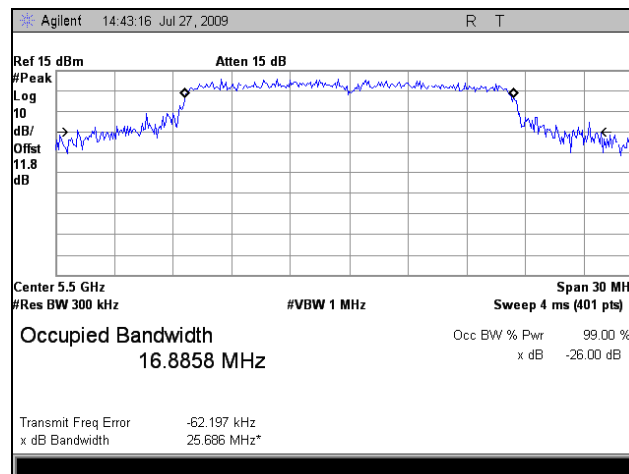

Plot 10. Occupied Bandwidth, Port 1, 802.11a, 5500 MHz

Occupied Bandwidth, Port 1

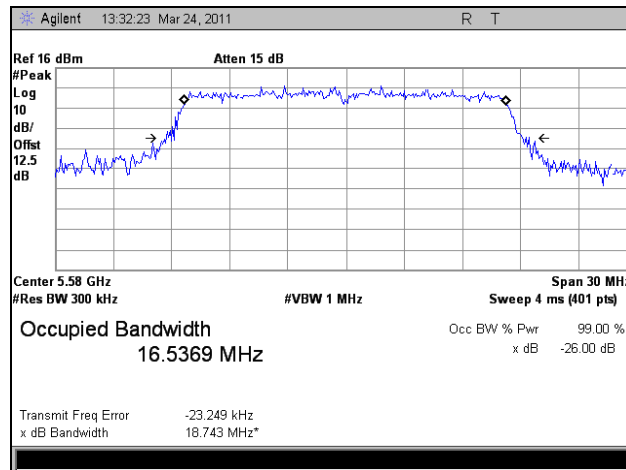

Plot 11. Occupied Bandwidth, Port 1, 802.11a, 5580 MHz

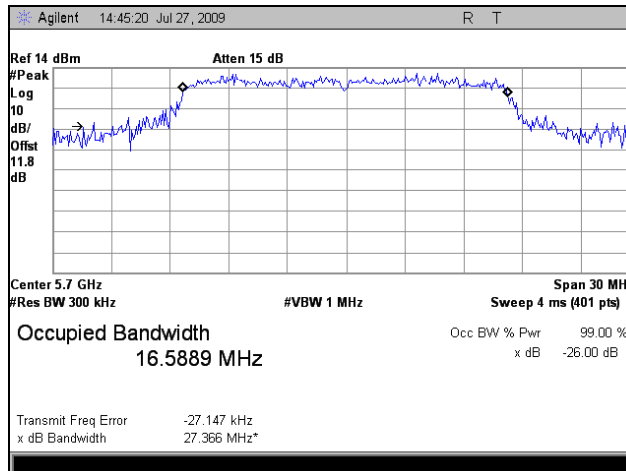

Plot 12. Occupied Bandwidth, Port 1, 802.11a, 5700 MHz

Occupied Bandwidth, Port 1, 802.11n 20MHz

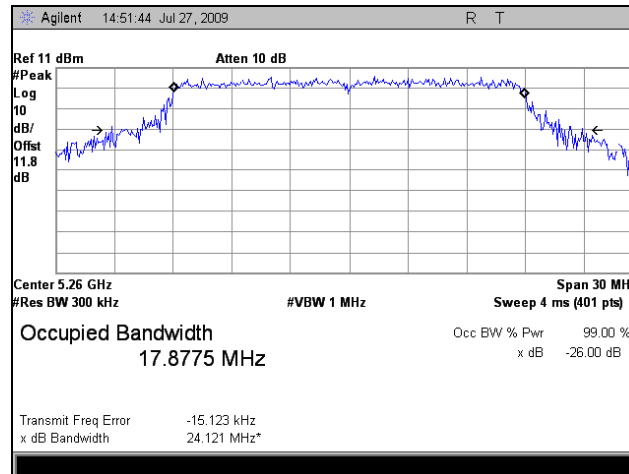

Plot 13. Occupied Bandwidth, Port 1, 802.11n 20MHz, 5260 MHz

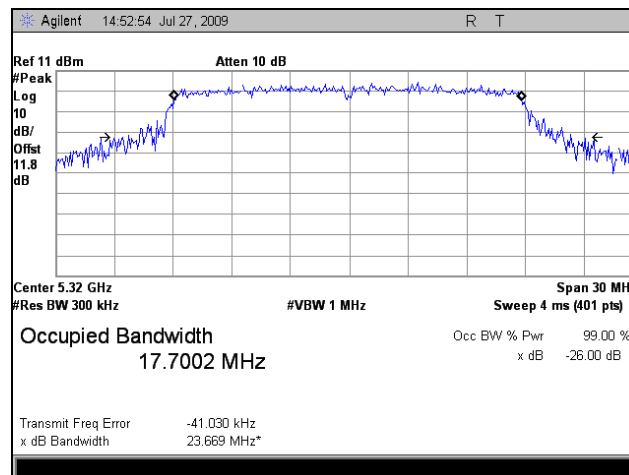

Plot 14. Occupied Bandwidth, Port 1, 802.11n 20MHz, 5320 MHz

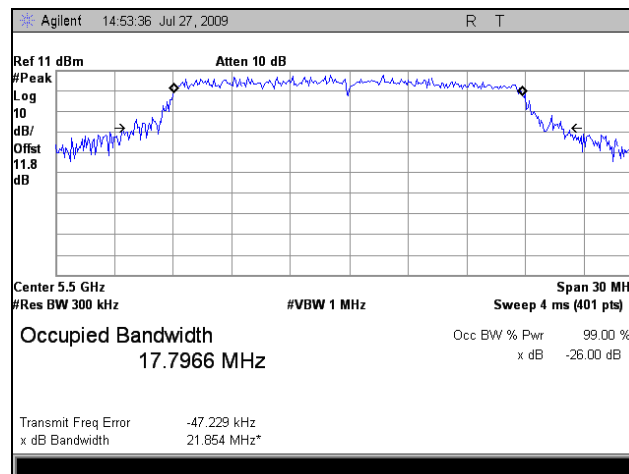

Plot 15. Occupied Bandwidth, Port 1, 802.11n 20MHz, 5500 MHz

Occupied Bandwidth, Port 1, 802.11n 20MHz

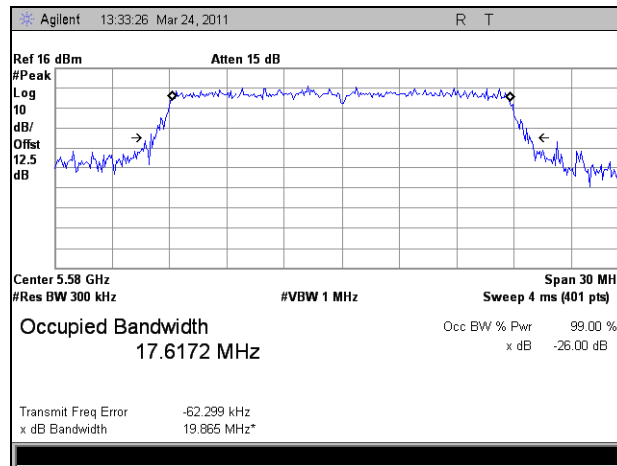

Plot 16. Occupied Bandwidth, Port 1, 802.11n 20MHz, 5580 MHz

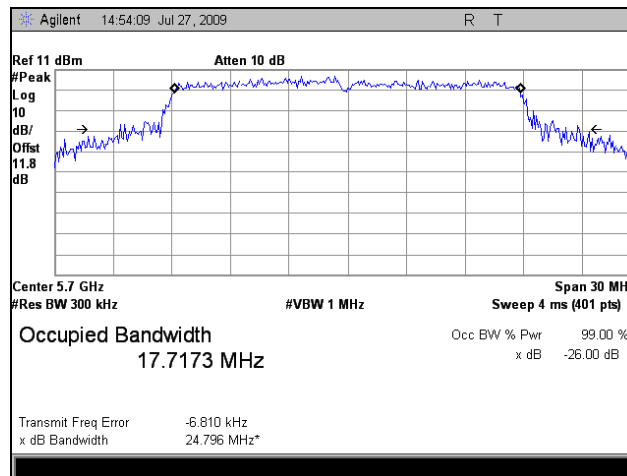

Plot 17. Occupied Bandwidth, Port 1, 802.11n 20MHz, 5700 MHz

Occupied Bandwidth, Port 1, 802.11n 40MHz

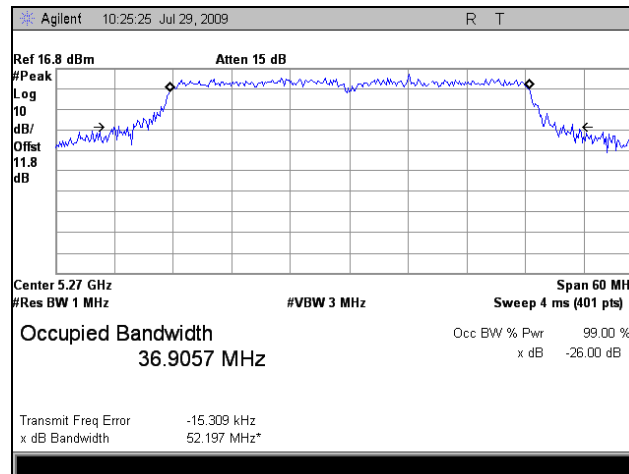

Plot 18. Occupied Bandwidth, Port 1, 802.11n 40MHz, 5270 MHz

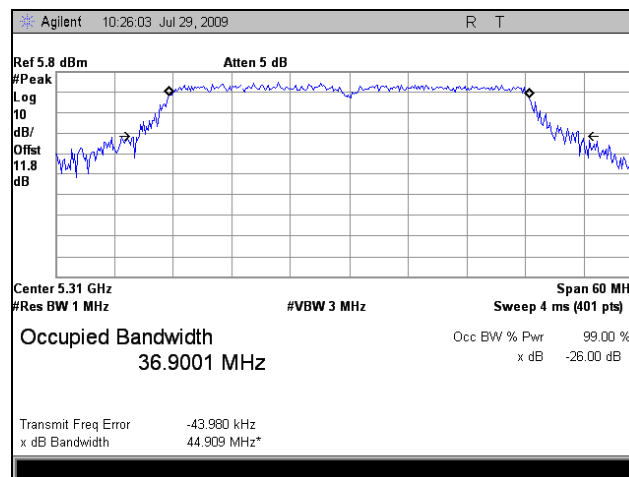

Plot 19. Occupied Bandwidth, Port 1, 802.11n 40MHz, 5310 MHz

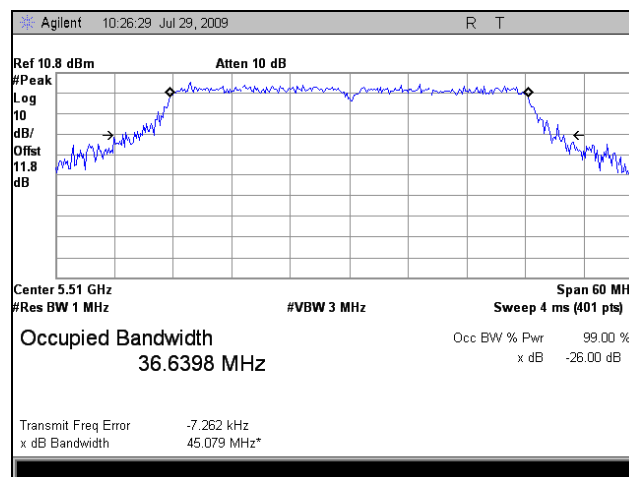

Plot 20. Occupied Bandwidth, Port 1, 802.11n 40MHz, 5510 MHz

Occupied Bandwidth, Port 1, 802.11n 40MHz

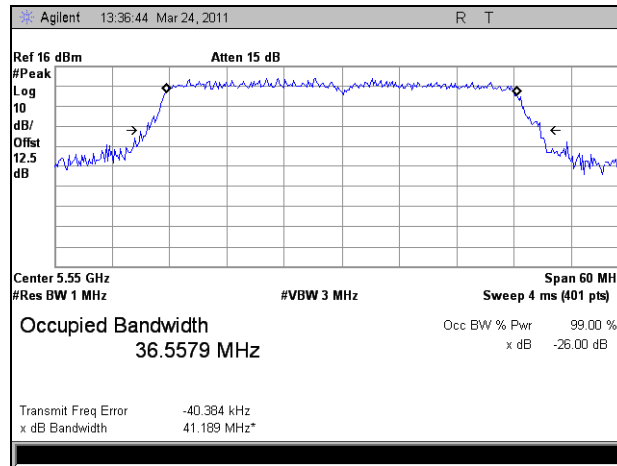

Plot 21. Occupied Bandwidth, Port 1, 802.11n 40MHz, 5550 MHz

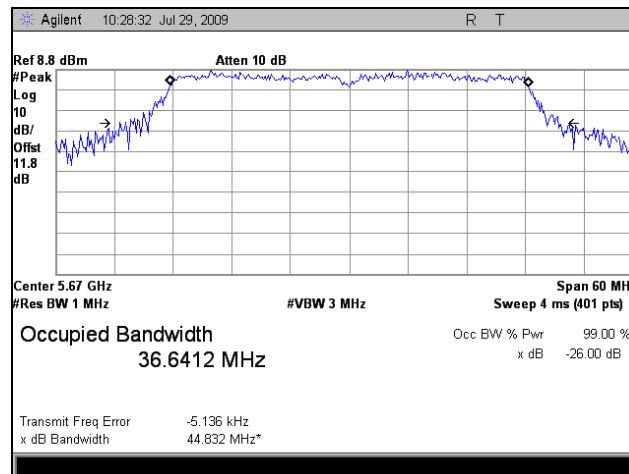

Plot 22. Occupied Bandwidth, Port 1, 802.11n 40MHz, 5670 MHz

Occupied Bandwidth, Port 2, 802.11n 20MHz

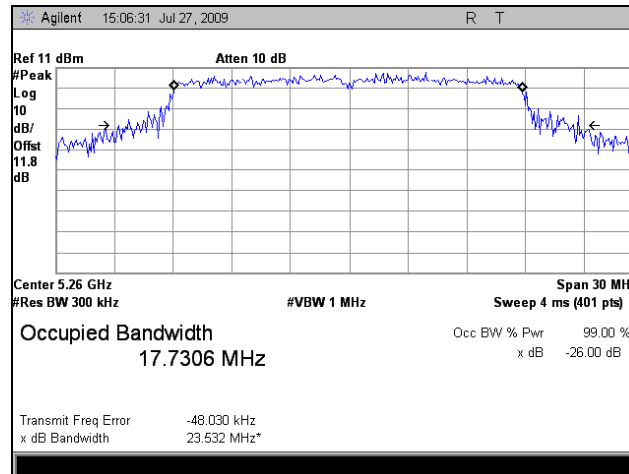

Plot 23. Occupied Bandwidth, Port 2, 802.11n 20MHz, 5260 MHz

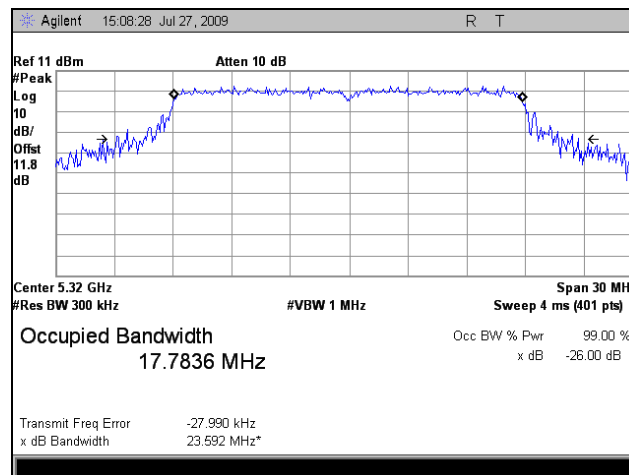

Plot 24. Occupied Bandwidth, Port 2, 802.11n 20MHz, 5320 MHz

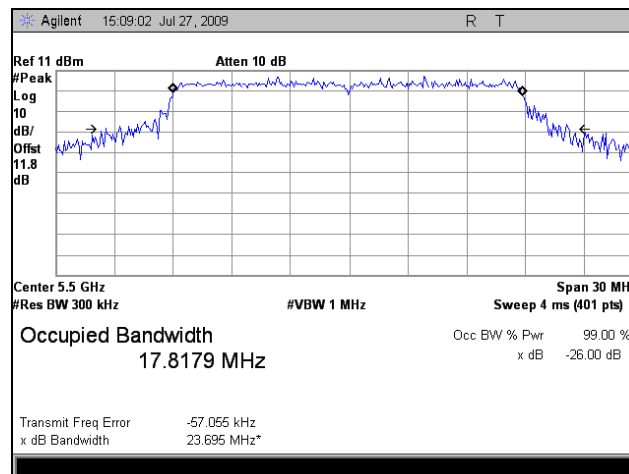

Plot 25. Occupied Bandwidth, Port 2, 802.11n 20MHz, 5500 MHz

Occupied Bandwidth, Port 2, 802.11n 20MHz

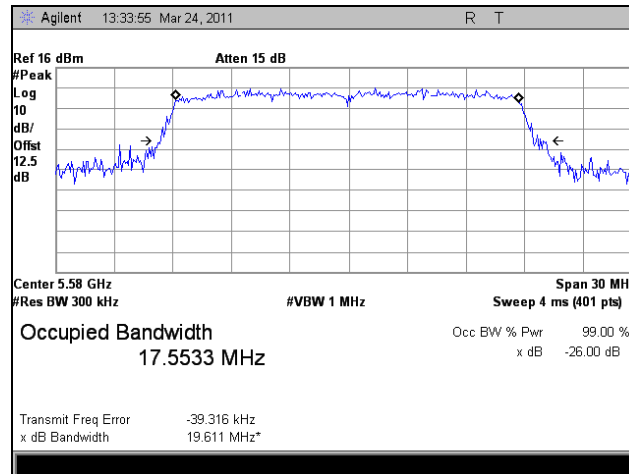

Plot 26. Occupied Bandwidth, Port 2, 802.11n 20MHz, 5580 MHz

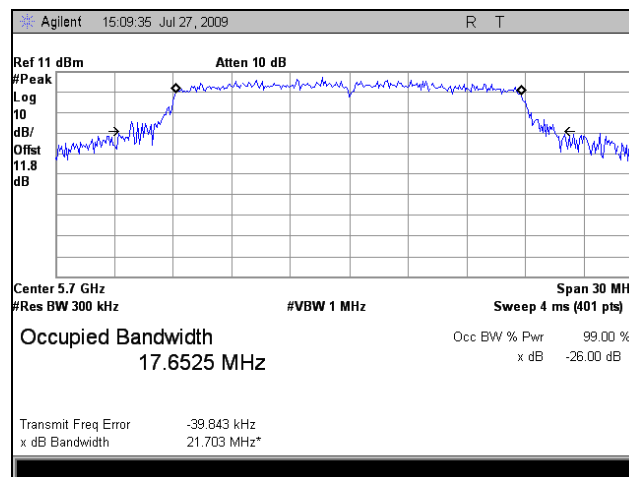

Plot 27. Occupied Bandwidth, Port 2, 802.11n 20MHz, 5700 MHz

Occupied Bandwidth, Port 2, 802.11n 40MHz

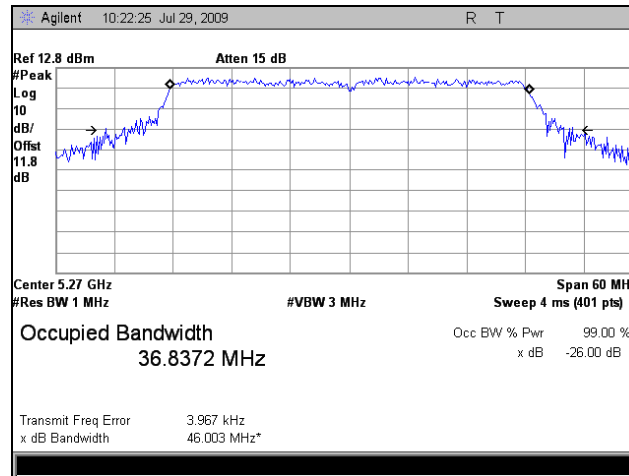

Plot 28. Occupied Bandwidth, Port 2, 802.11n 40MHz, 5270 MHz

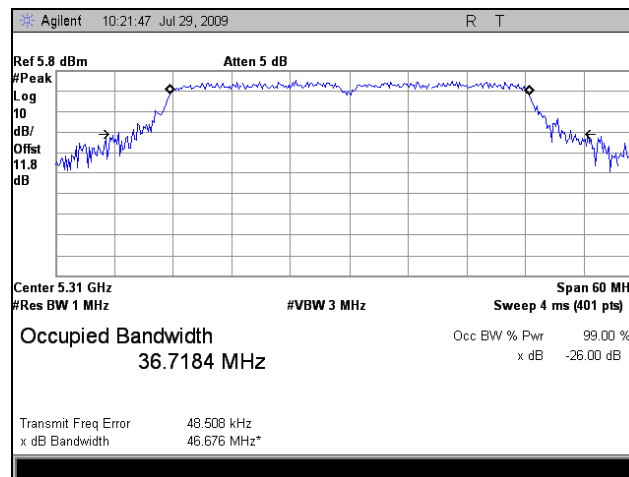

Plot 29. Occupied Bandwidth, Port 2, 802.11n 40MHz, 5310 MHz

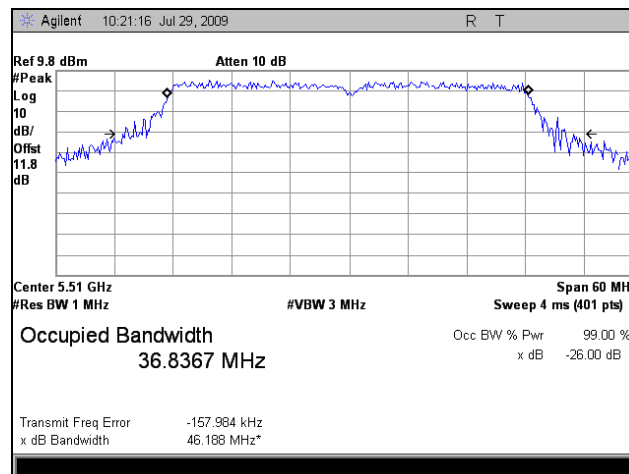

Plot 30. Occupied Bandwidth, Port 2, 802.11n 40MHz, 5510 MHz

Occupied Bandwidth, Port 2, 802.11n 40MHz

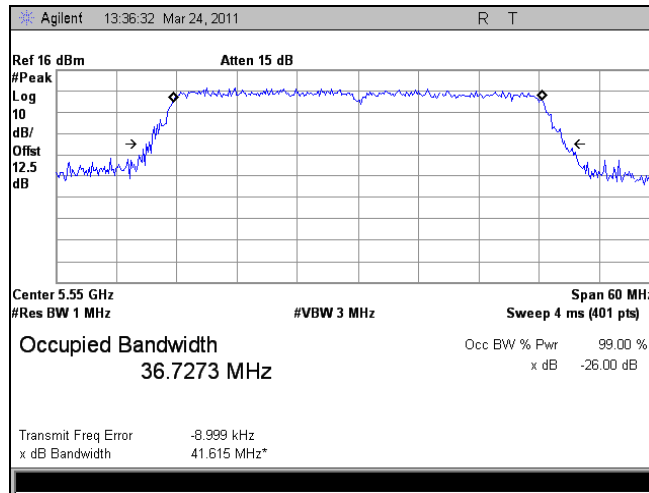

Plot 31. Occupied Bandwidth, Port 2, 802.11n 40MHz, 5550 MHz

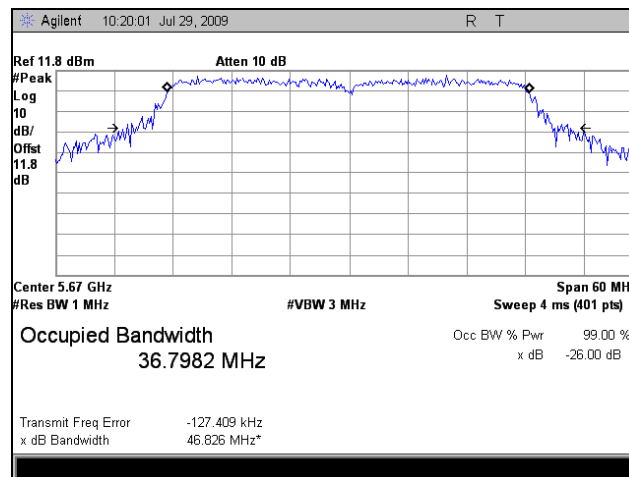

Plot 32. Occupied Bandwidth, Port 2, 802.11n 40MHz, 5670 MHz

Occupied Bandwidth, Port 3, 802.11n 20MHz

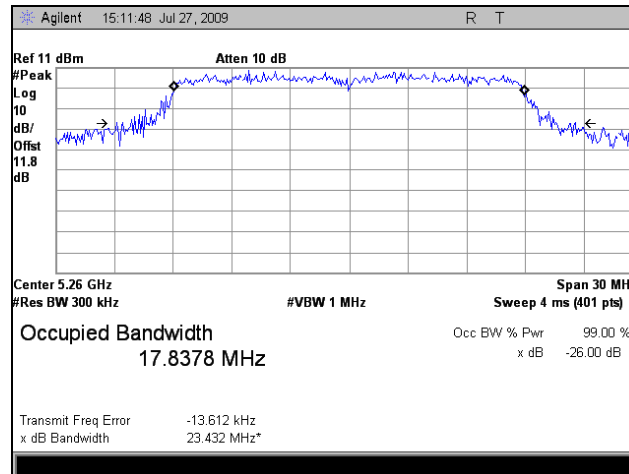

Plot 33. Occupied Bandwidth, Port 3, 802.11n 20MHz, 5260 MHz

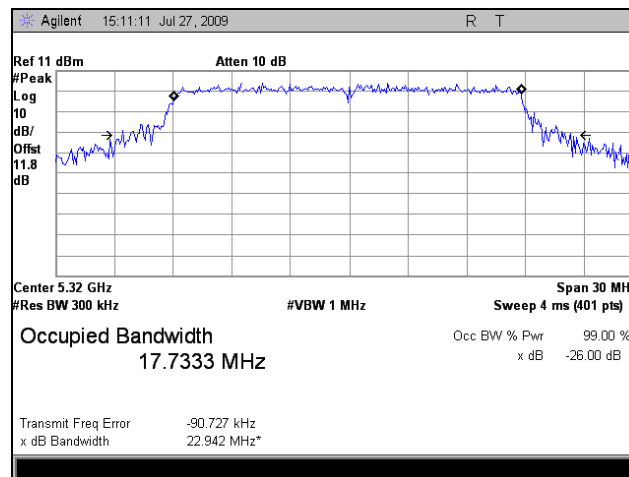

Plot 34. Occupied Bandwidth, Port 3, 802.11n 20MHz, 5320 MHz

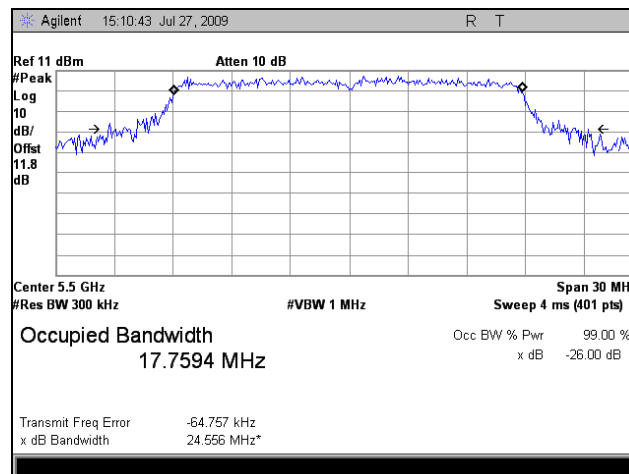

Plot 35. Occupied Bandwidth, Port 3, 802.11n 20MHz, 5500 MHz

Occupied Bandwidth, Port 3, 802.11n 20MHz

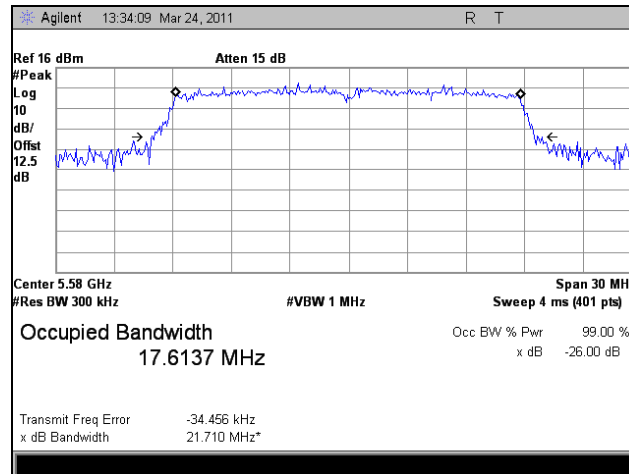

Plot 36. Occupied Bandwidth, Port 3, 802.11n 20MHz, 5580 MHz

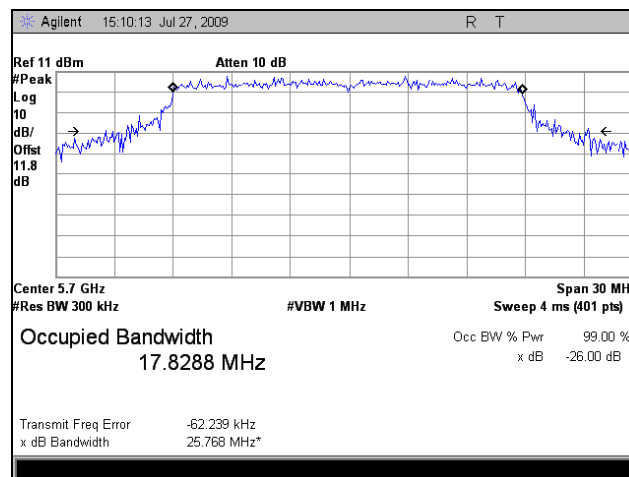

Plot 37. Occupied Bandwidth, Port 3, 802.11n 20MHz, 5700 MHz

Occupied Bandwidth, Port 3, 802.11n 40MHz

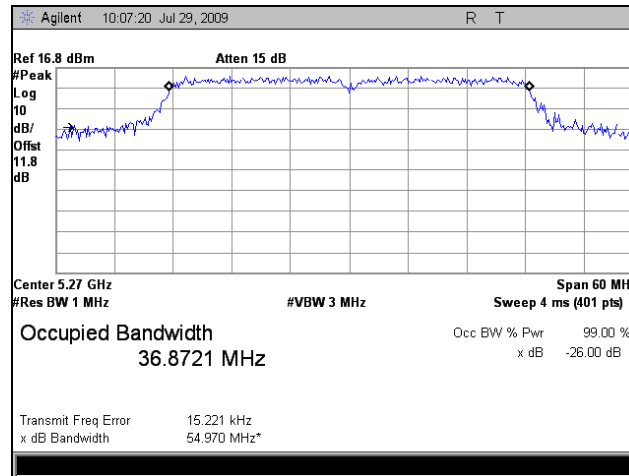

Plot 38. Occupied Bandwidth, Port 3, 802.11n 40MHz, 5270 MHz

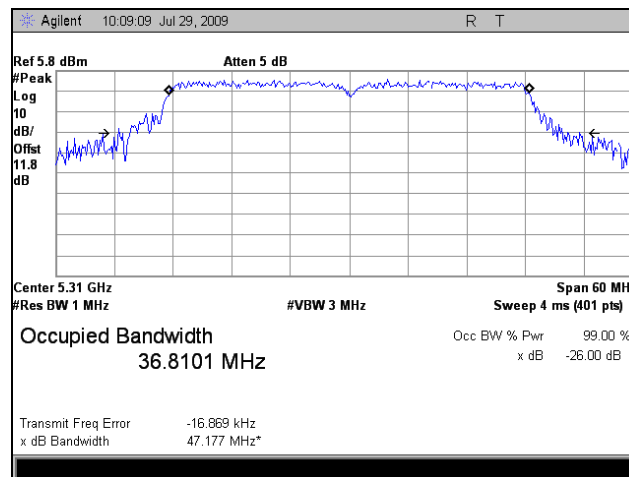

Plot 39. Occupied Bandwidth, Port 3, 802.11n 40MHz, 5310 MHz

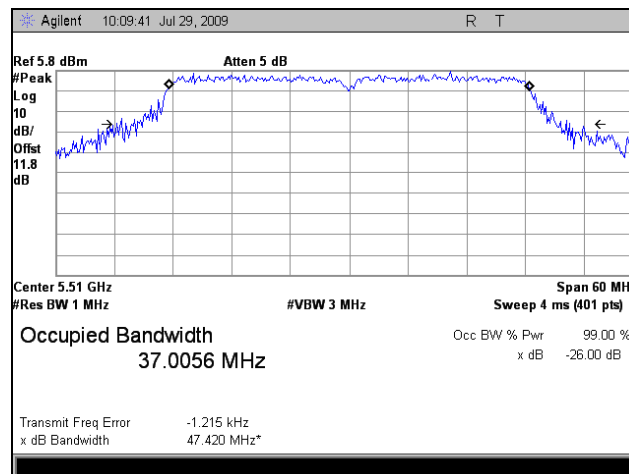

Plot 40. Occupied Bandwidth, Port 3, 802.11n 40MHz, 5510 MHz

Occupied Bandwidth, Port 3, 802.11n 40MHz

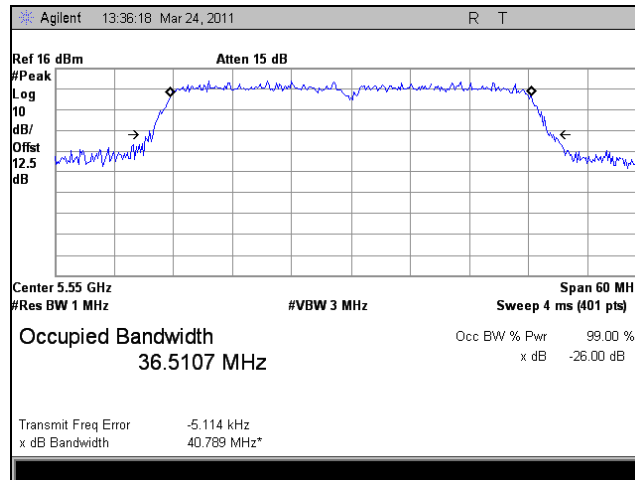

Plot 41. Occupied Bandwidth, Port 3, 802.11n 40MHz, 5550 MHz

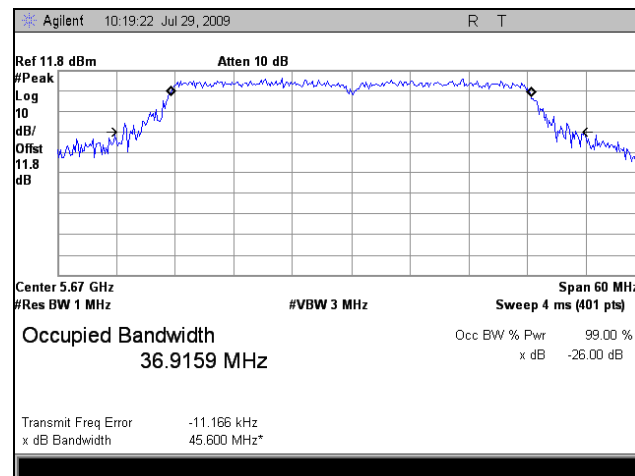

Plot 42. Occupied Bandwidth, Port 3, 802.11n 40MHz, 5670 MHz

99% Occupied Bandwidth, Port 1

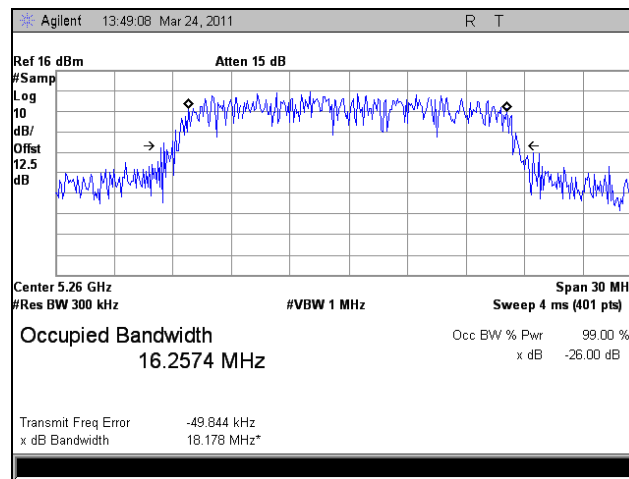

Plot 43. 99% Occupied Bandwidth, Port 1, 802.11a, 5260 MHz

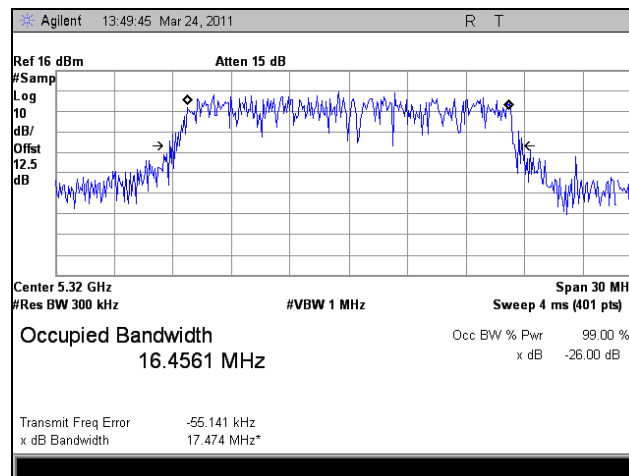

Plot 44. 99% Occupied Bandwidth, Port 1, 802.11a, 5320 MHz

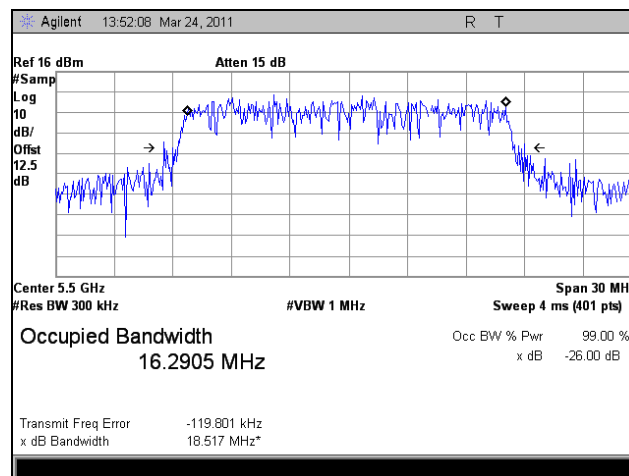

Plot 45. 99% Occupied Bandwidth, Port 1, 802.11a, 5500 MHz

99% Occupied Bandwidth, Port 1

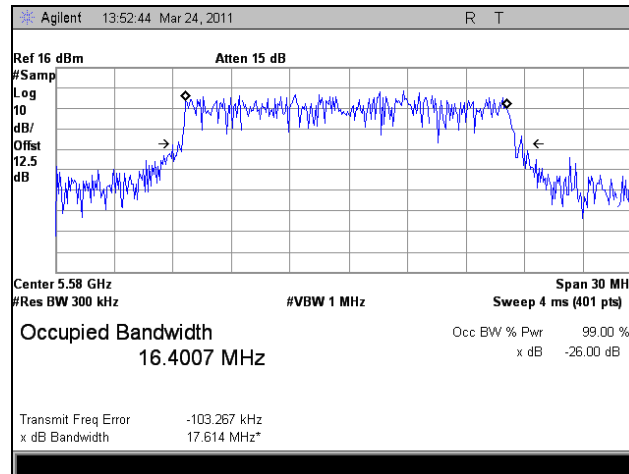

Plot 46. 99% Occupied Bandwidth, Port 1, 802.11a, 5580 MHz

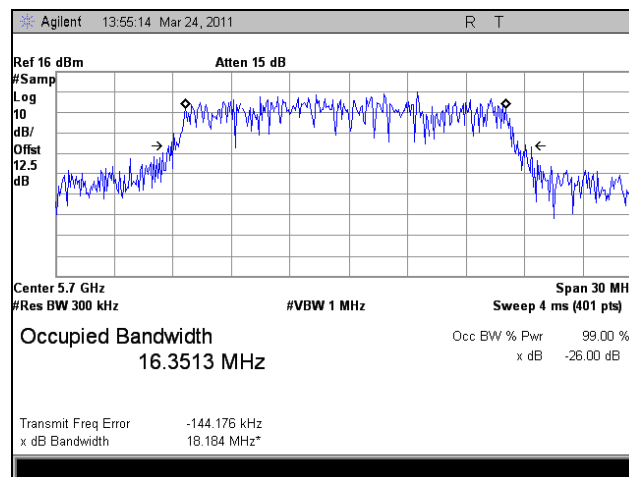

Plot 47. 99% Occupied Bandwidth, Port 1, 802.11a, 5700 MHz

99% Occupied Bandwidth, Port 1, 802.11n 20MHz

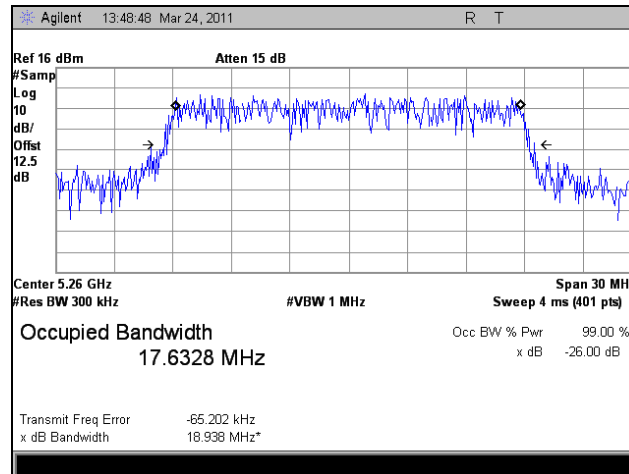

Plot 48. 99% Occupied Bandwidth, Port 1, 802.11n 20MHz, 5260 MHz

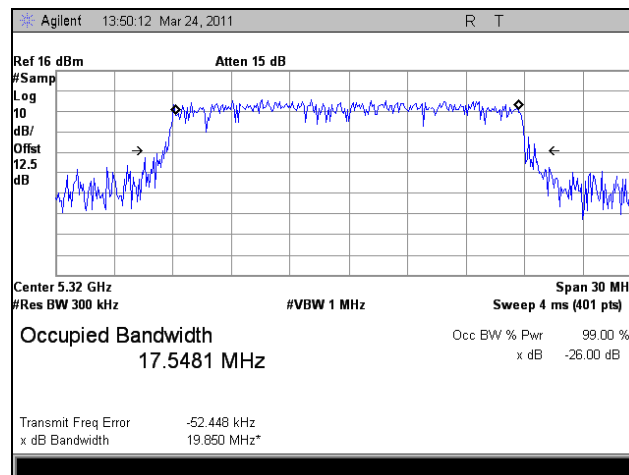

Plot 49. 99% Occupied Bandwidth, Port 1, 802.11n 20MHz, 5320 MHz

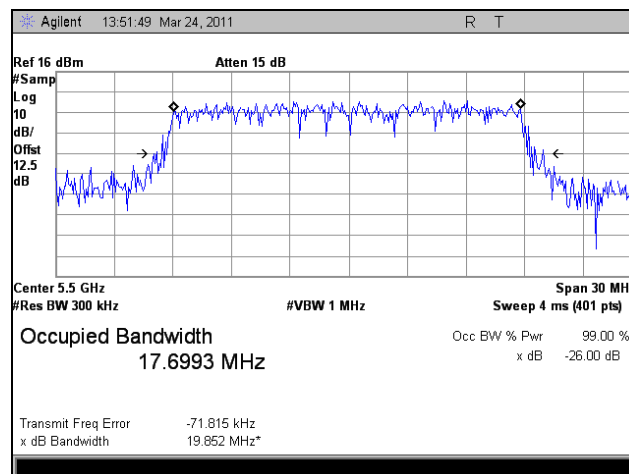

Plot 50. 99% Occupied Bandwidth, Port 1, 802.11n 20MHz, 5500 MHz

99% Occupied Bandwidth, Port 1, 802.11n 20MHz

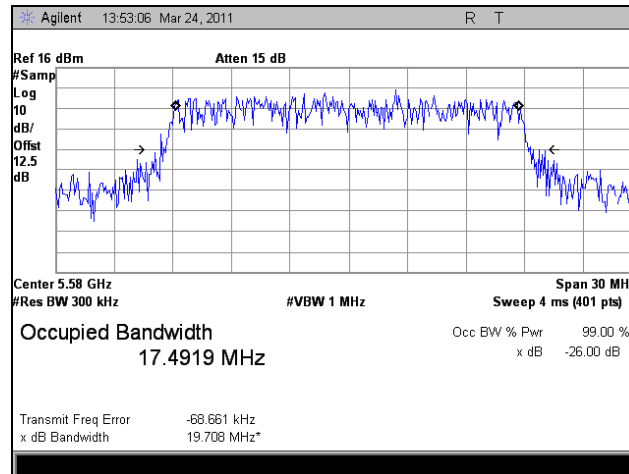

Plot 51. 99% Occupied Bandwidth, Port 1, 802.11n 20MHz, 5580 MHz

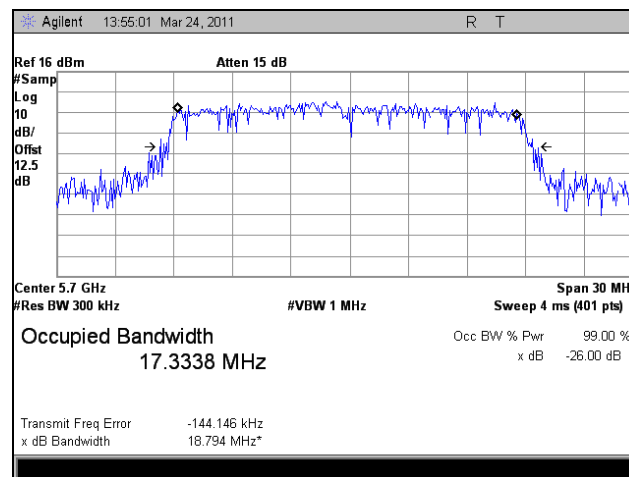

Plot 52. 99% Occupied Bandwidth, Port 1, 802.11n 20MHz, 5700 MHz

99% Occupied Bandwidth, Port 1, 802.11n 40MHz

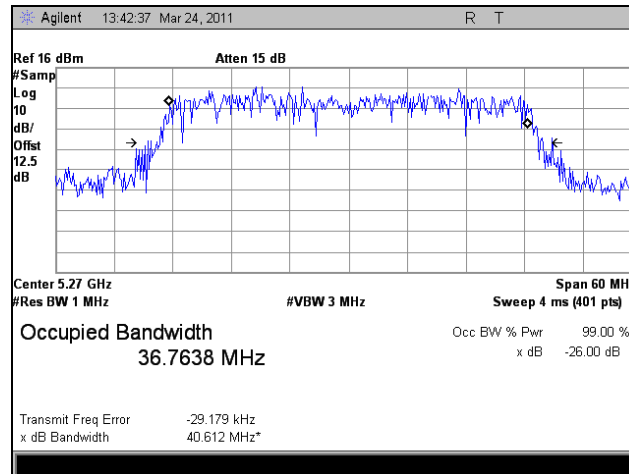

Plot 53. 99% Occupied Bandwidth, Port 1, 802.11n 40MHz, 5270 MHz

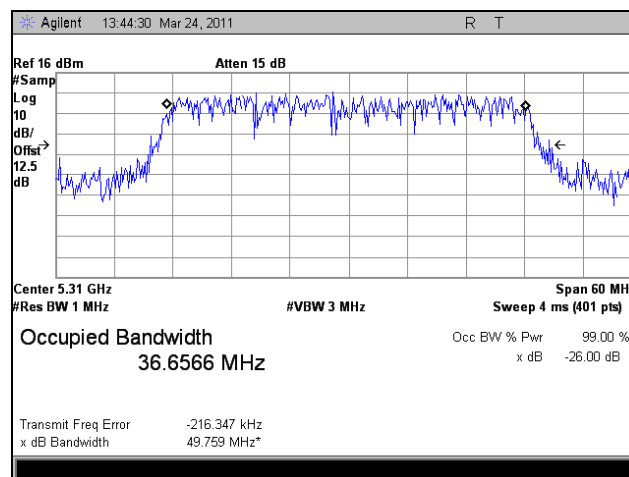

Plot 54. 99% Occupied Bandwidth, Port 1, 802.11n 40MHz, 5310 MHz

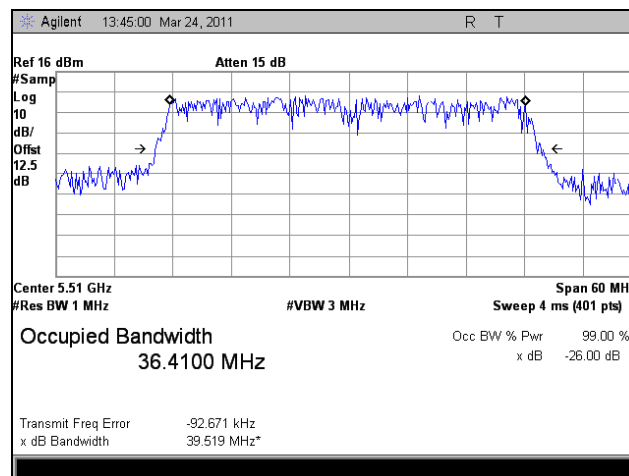

Plot 55. 99% Occupied Bandwidth, Port 1, 802.11n 40MHz, 5510 MHz

99% Occupied Bandwidth, Port 1, 802.11n 40MHz

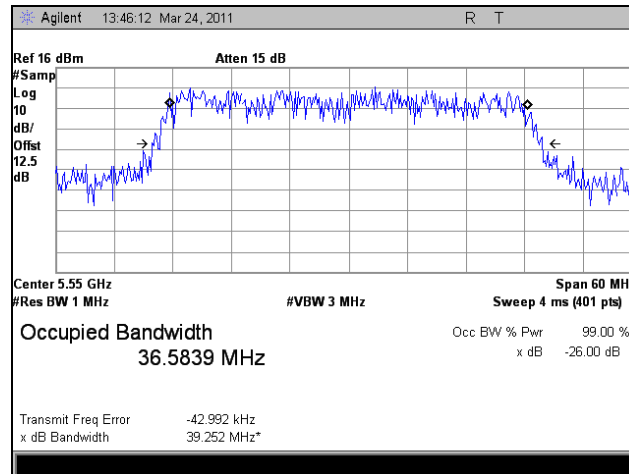

Plot 56. 99% Occupied Bandwidth, Port 1, 802.11n 40MHz, 5550 MHz

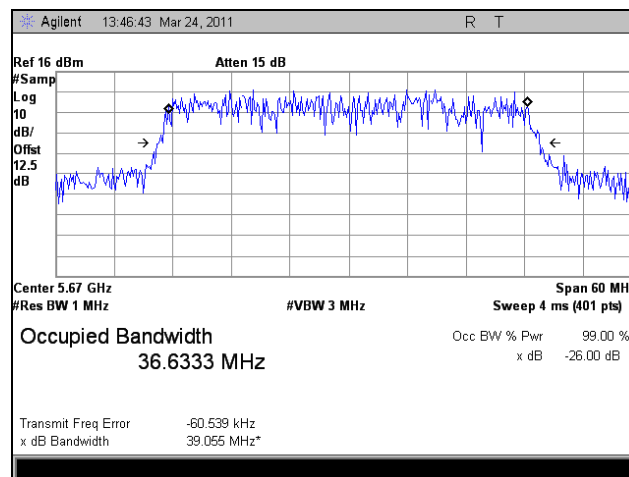

Plot 57. 99% Occupied Bandwidth, Port 1, 802.11n 40MHz, 5670 MHz

99% Occupied Bandwidth, Port 2, 802.11n 20MHz

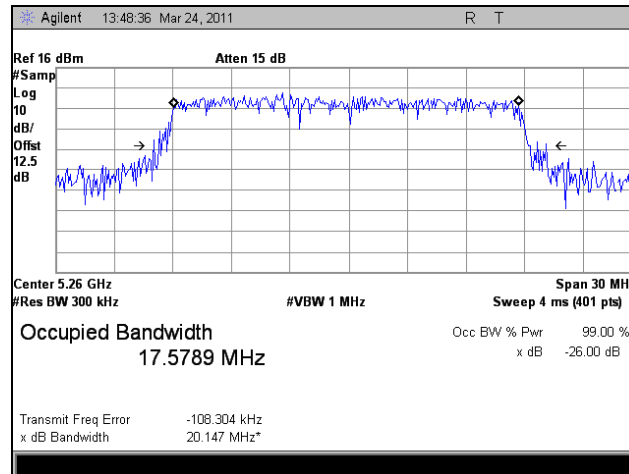

Plot 58. 99% Occupied Bandwidth, Port 2, 802.11n 20MHz, 5260 MHz

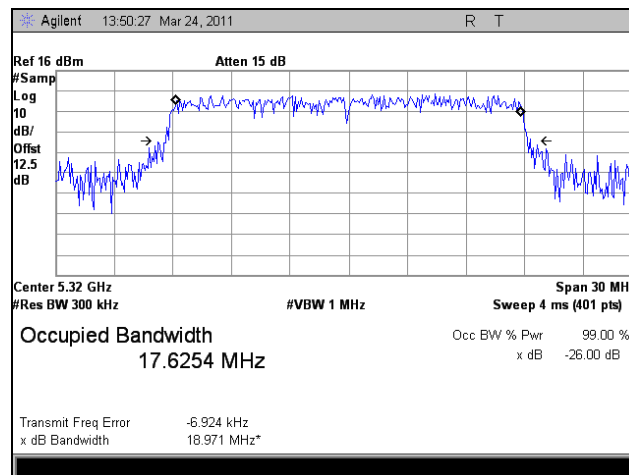

Plot 59. 99% Occupied Bandwidth, Port 2, 802.11n 20MHz, 5320 MHz

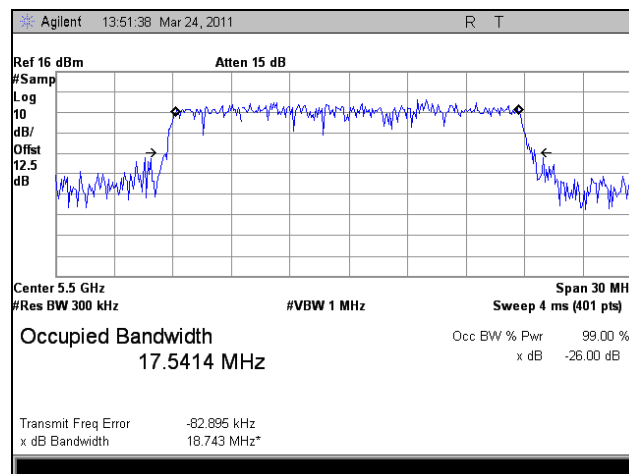

Plot 60. 99% Occupied Bandwidth, Port 2, 802.11n 20MHz, 5500 MHz

99% Occupied Bandwidth, Port 2, 802.11n 20MHz

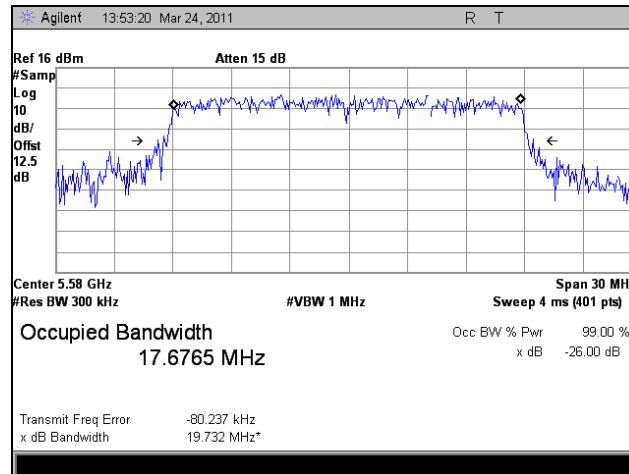

Plot 61. 99% Occupied Bandwidth, Port 2, 802.11n 20MHz, 5580 MHz

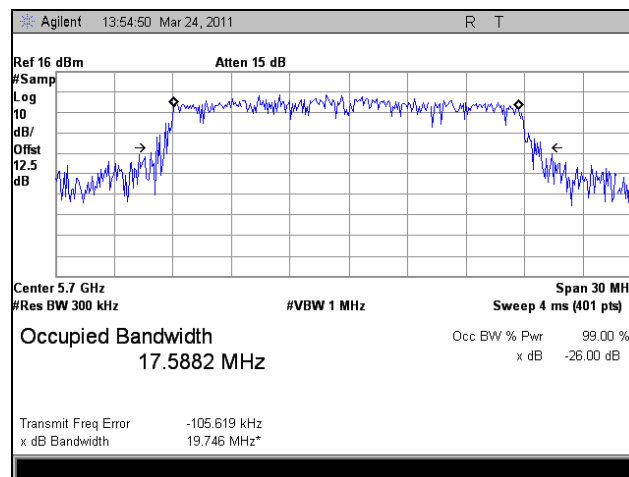

Plot 62. 99% Occupied Bandwidth, Port 2, 802.11n 20MHz, 5700 MHz

99% Occupied Bandwidth, Port 2, 802.11n 40MHz

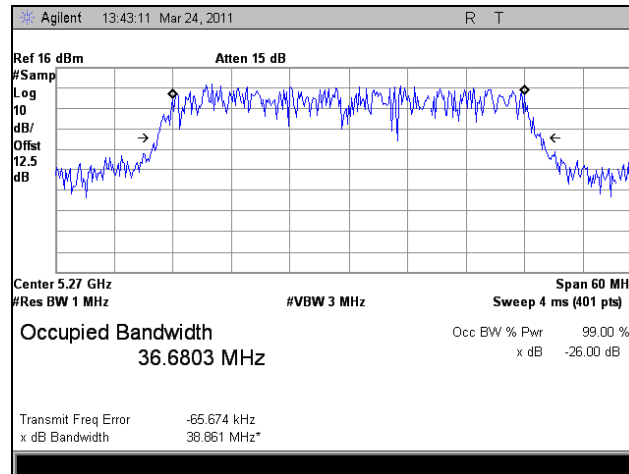

Plot 63. 99% Occupied Bandwidth, Port 2, 802.11n 40MHz, 5270 MHz

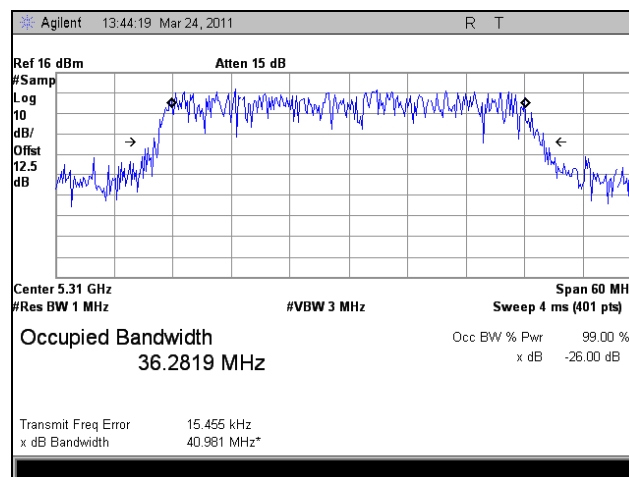

Plot 64. 99% Occupied Bandwidth, Port 2, 802.11n 40MHz, 5310 MHz

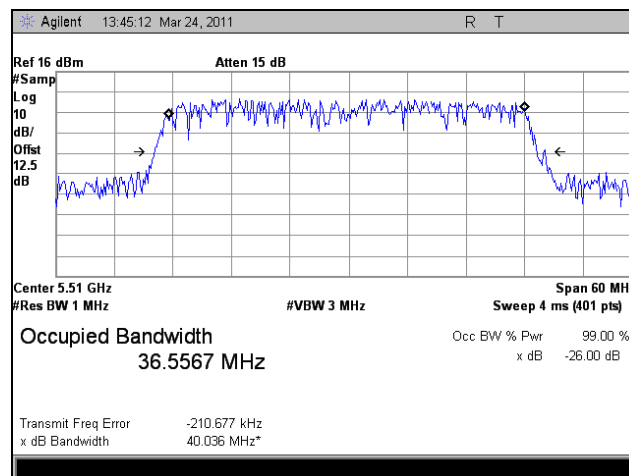

Plot 65. 99% Occupied Bandwidth, Port 2, 802.11n 40MHz, 5510 MHz

99% Occupied Bandwidth, Port 2, 802.11n 40MHz

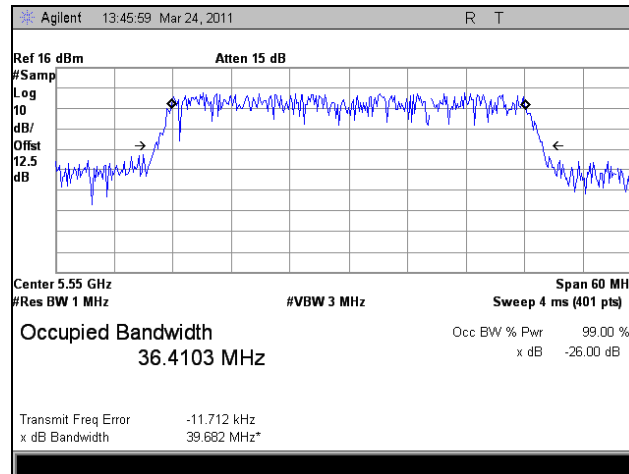

Plot 66. 99% Occupied Bandwidth, Port 2, 802.11n 40MHz, 5550 MHz

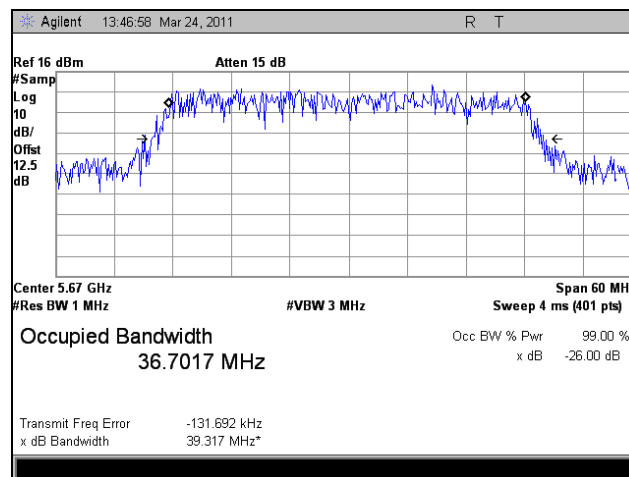

Plot 67. 99% Occupied Bandwidth, Port 2, 802.11n 40MHz, 5670 MHz

99% Occupied Bandwidth, Port 3, 802.11n 20MHz

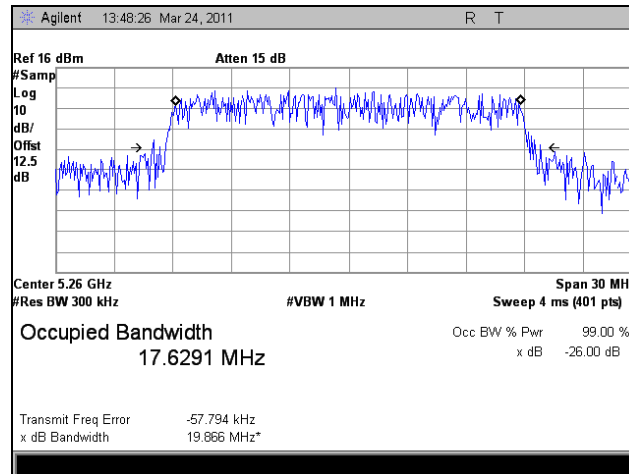

Plot 68. 99% Occupied Bandwidth, Port 3, 802.11n 20MHz, 5260 MHz

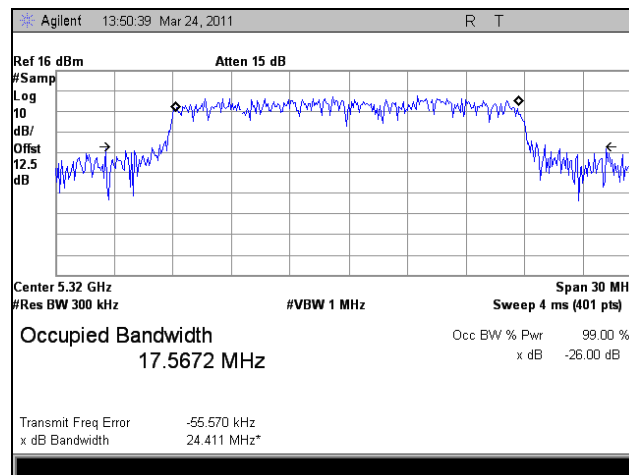

Plot 69. 99% Occupied Bandwidth, Port 3, 802.11n 20MHz, 5320 MHz

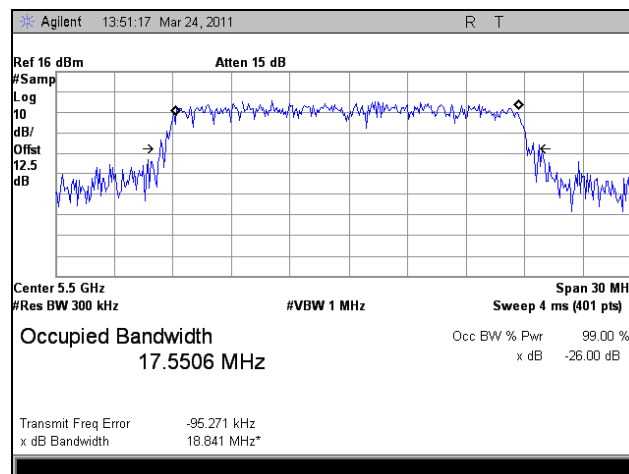

Plot 70. 99% Occupied Bandwidth, Port 3, 802.11n 20MHz, 5500 MHz

99% Occupied Bandwidth, Port 3, 802.11n 20MHz

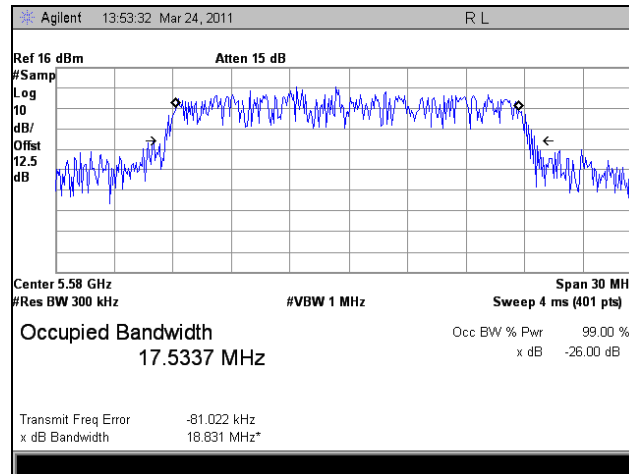

Plot 71. 99% Occupied Bandwidth, Port 3, 802.11n 20MHz, 5580 MHz

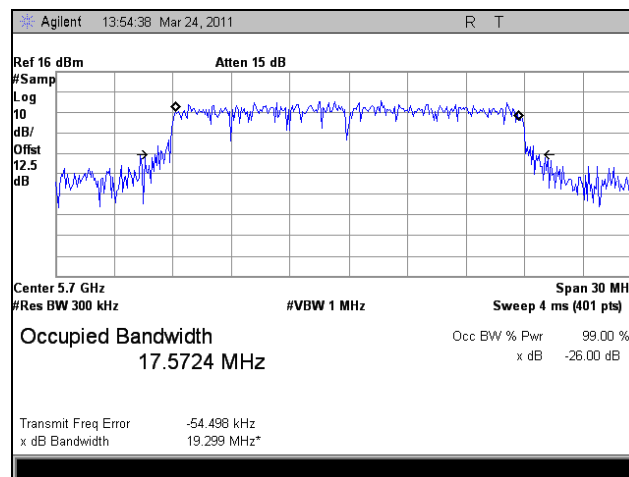

Plot 72. 99% Occupied Bandwidth, Port 3, 802.11n 20MHz, 5700 MHz

99% Occupied Bandwidth, Port 3, 802.11n 40MHz

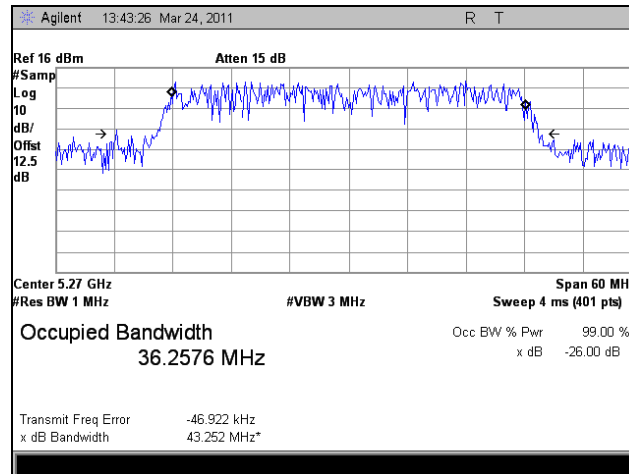

Plot 73. 99% Occupied Bandwidth, Port 3, 802.11n 40MHz, 5270 MHz

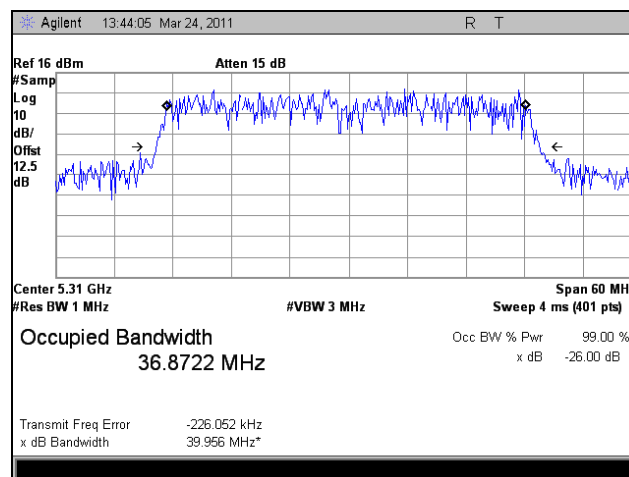

Plot 74. 99% Occupied Bandwidth, Port 3, 802.11n 40MHz, 5310 MHz

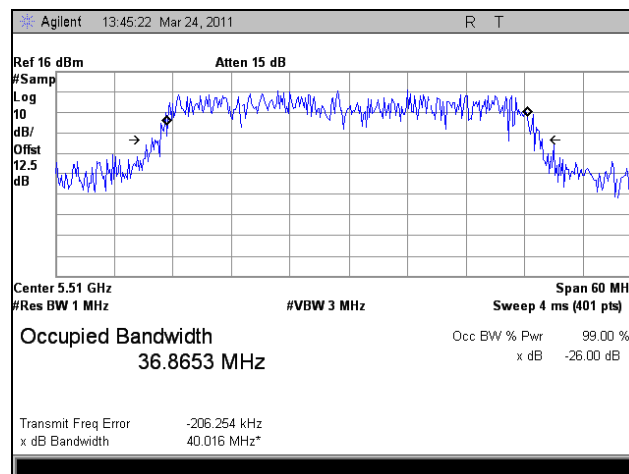

Plot 75. 99% Occupied Bandwidth, Port 3, 802.11n 40MHz, 5510 MHz

99% Occupied Bandwidth, Port 3, 802.11n 40MHz

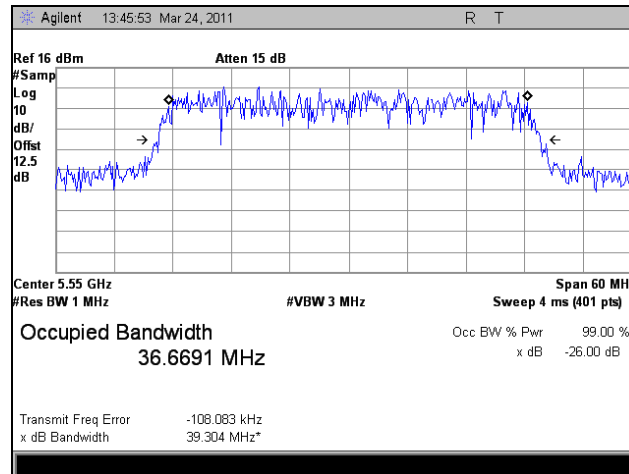

Plot 76. 99% Occupied Bandwidth, Port 3, 802.11n 40MHz, 5550 MHz

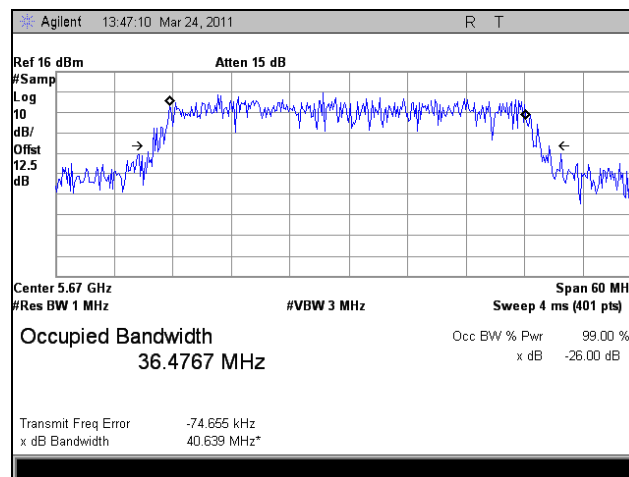

Plot 77. 99% Occupied Bandwidth, Port 3, 802.11n 40MHz, 5670 MHz

Electromagnetic Compatibility Criteria for Intentional Radiators

§ 15.407(a) (1), (2) RF Power Output

Test Requirements: §15.407(a) (1), (2): The maximum output power of the intentional radiator shall not exceed the following:

Digital Transmission Systems (MHz)	Output Limit (mW)
5150-5250	50
5250-5350	250

Table 19. Output Power Requirements from §15.407

§15.407(a) (1): For the band 5.15-5.25 GHz the peak transmit power over the frequency band of operation shall not exceed the lesser 50mW or $4\text{dBm} + 10\log B$, where B is the 26-dB emission bandwidth in MHz.

§15.407(a) (2): For the band 5.25-5.35GHz & 5.470-5.72GHz the peak transmit power over the frequency band of operation shall not exceed the lesser of 250mW or $11\text{dBm} + 10\log B$, where B is the 26-dB emission bandwidth in MHz.

Test Procedure: The transmitter was connected to a calibrated Spectrum analyzer. The EUT was measured at the low, mid and high channels of each band with the data rate that produced the highest output power.

Test Results: Equipment complies with the Peak Power Output limits of § 15.401(a) (2)

Test Engineer(s): Minh Ly

Test Date(s): 07/28/09 - 08/11/09

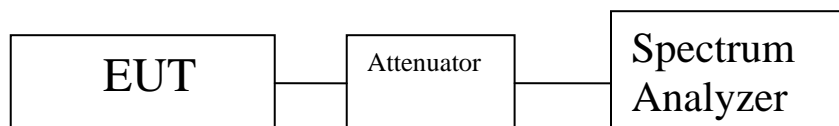

Figure 3. Peak Power Output Test Setup

7200 Outdoor 802.11a			
Mode	Frequency (MHz)		Measured Output Power (dBm)
802.11a	UNII-2 Lower Band	5260	15.59
		5320	16.85
	UNII-2 Upper Band	5500	19.55
		5580	20.21
		5700	19.35

7200 Outdoor, Summed Power (n mode)						
Mode	Frequency (MHz)		Port 1	Port 2	Port 3	Summed Power (dBm)
802.11n 20MHz	UNII-2 Lower Band	5260	15.91	15.06	15.31	20.21
		5320	14.74	13.11	14.65	19.00
	UNII-2 Upper Band	5500	15.57	15.14	15.02	20.02
		5580	15.34	15.22	15.65	20.18
		5700	15.20	15.07	15.49	20.03
802.11n 40MHz	UNII-2 Lower Band	5270	15.11	15.12	15.83	20.14
		5310	6.43	7.07	7.61	11.83
	UNII-2 Upper Band	5510	11.02	10.18	10.80	15.45
		5550	15.21	15.41	15.05	20.00
		5670	11.39	14.42	13.82	18.17

Table 20. RF Power Output, Test Results, Summed Power

Electromagnetic Compatibility Criteria for Intentional Radiators

§ 15.407(a)(1), (a)(2) Peak Power Spectral Density

Test Requirements: § 15.407(a)(1), (a)(2): For digitally modulated systems, the conducted peak power spectral density from the intentional radiator to the antenna shall not be greater than 4dBm/MHz in the frequency band 5.15-5.25 GHz and 11dBm/MHz in the frequency band 5.25-5.35GHz.

Test Procedure: The transmitter was connected directly to a Spectrum Analyzer through an attenuator. The power level was set to the maximum level on the EUT. The RBW was set to 1MHz and the VBW was set to 3MHz. The method of measurement #2 from the FCC Public Notice CA 02-2138 was used.

Test Results: Equipment complies with the peak power spectral density limits of § 15.407(a)(1), (a)(2). The peak power spectral density was determined from plots on the following page(s).

Test Engineer(s): Minh Ly

Test Date(s): 07/28/09 – 08/11/09

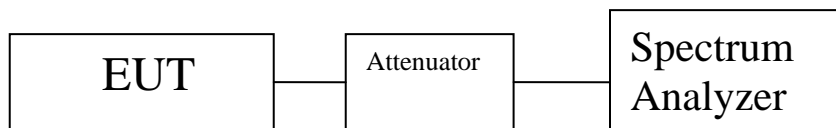

Figure 4. Peak Power Spectral Density Test Setup

1720 IntelliCom a Mode				
Mode	Frequency	Measured PPSD	Limit	Margin
	(MHz)	(dBm)	(dBm)	(dB)
802.11a	5260	4.342	11	6.658
	5320	4.682	11	6.318
	5500	8.358	11	2.642
	5580	8.253	11	2.747
	5700	8.450	11	2.550

Table 21. Power Spectral Density, 802.11a, Test Results

1720 IntelliCom n Mode							
Mode	Frequency	Port 1	Port 2	Port 3	Summed	Limit*	Margin
	(MHz)	(dBm)	(dBm)	(dBm)	(dBm)	(dBm)	(dB)
802.11n 20MHz	5270	1.569	1.873	1.970	6.579	7.22	-0.641
	5310	1.874	2.003	2.033	6.742	7.22	-0.478
	5510	1.828	1.631	1.418	6.400	7.22	-0.820
	5550	1.943	1.930	1.540	6.580	7.22	-0.640
	5670	1.975	1.603	1.925	6.609	7.22	-0.611
802.11n 40MHz	5270	1.224	1.988	1.440	6.334	7.22	-0.886
	5310	-7.480	-7.634	-6.795	-2.516	7.22	-9.736
	5510	-4.089	-4.152	-4.110	0.654	7.22	-6.566
	5550	1.785	0.189	1.845	6.109	7.22	-1.111
	5670	-2.097	-0.142	1.043	4.558	7.22	-2.662

Table 22. Power Spectral Density, 802.11n, Test Results, Port 1-3 & Summed

*Note Limit was corrected for the use of three 5dBi Antennas. Sum of three 5dBi Antennas is equal to 9.77dBi Gain.

Electromagnetic Compatibility Criteria for Intentional Radiators

§ 15.407(a)(6) Peak Excursion Ratio

Test Requirements: § 15.407(a)(6): For digitally modulated systems, the peak excursion of the modulation envelope to the peak transmit power shall not exceed 13dB across any 1MHz bandwidth of the emission bandwidth whichever is less.

Test Procedure: The method of measurement #2 from the FCC Public Notice CA 02-2138 was used. The EUT was connected directly to the spectrum analyzer through cabling and attenuation. The 1st trace on the spectrum analyzer was set to RBW=1MHz, VBW=3MHz. The peak detector mode was used and the trace max held. The 2nd trace on the spectrum analyzer was set to a RBW=1MHz, VBW=30 KHz. The detector mode was set to sample detector.

The Peak Excursion Ratio was determined from the difference between the maximum found in each trace.

Test Results: Equipment complies with the peak excursion ratio limits of § 15.407(a)(6). The peak excursion ratio was determined from plots on the following page(s).

Test Engineer(s): Minh Ly

Test Date(s): 07/28/09 - 08/11/09

1720 IntelliCom, Port 1				
Mode	Frequency (MHz)	Excursion Ratio (dBm)	Limit (dBm)	Margin (dB)
802.11a	5260	9.087	13	3.913
	5320	9.009	13	3.991
	5500	9.613	13	3.387
	5580	11.37	13	1.63
	5700	9.827	13	3.173
802.11n 20MHz	5260	10.32	13	2.68
	5320	11.53	13	1.47
	5500	10.65	13	2.35
	5580	10.26	13	2.74
	5700	10.79	13	2.21
802.11n 40MHz	5270	12.71	13	0.29
	5310	12.65	13	0.35
	5510	12.59	13	0.41
	5550	10.68	13	2.32
	5670	11.73	13	1.27

Table 23. Peak Excursion Ratio, Test Results, Port 1

1720 IntelliCom, Port 2				
Mode	Frequency (MHz)	Excursion Ratio (dBm)	Limit (dBm)	Margin (dB)
802.11n 20MHz	5260	10.33	13	2.67
	5320	9.634	13	3.366
	5500	11.02	13	1.98
	5580	11.27	13	1.73
	5700	10.63	13	2.37
802.11n 40MHz	5270	12.95	13	0.05
	5310	11.98	13	1.02
	5510	11.73	13	1.27
	5550	10.52	13	2.48
	5670	9.8	13	3.2

Table 24. Peak Excursion Ratio, Test Results, Port 2

1720 IntelliCom, Port 3				
Mode	Frequency (MHz)	Excursion Ratio (dBm)	Limit (dBm)	Margin (dB)
802.11n 20MHz	5260	11.96	13	1.04
	5320	9.529	13	3.471
	5500	10.11	13	2.89
	5580	10.24	13	2.76
	5700	8.677	13	4.323
802.11n 40MHz	5270	12.86	13	0.14
	5310	12.17	13	0.83
	5510	12.6	13	0.4
	5550	11.2	13	1.8
	5670	12	13	1

Table 25. Peak Excursion Ratio, Test Results, Port 3

Peak Excursion Ratio, Port 1, 802.11a

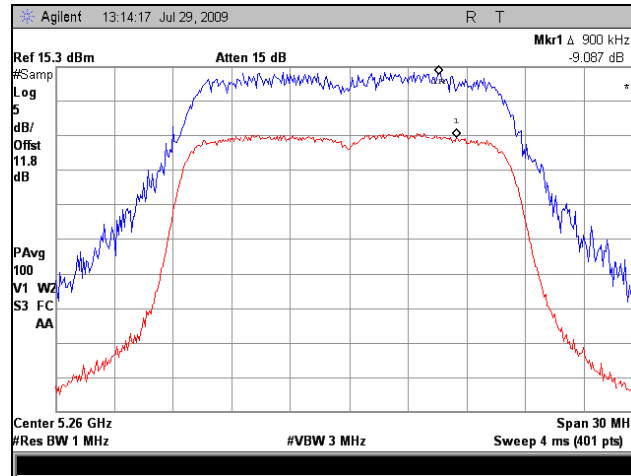

Plot 78. Peak Excursion, Port 1, 802.11a, 5260 MHz

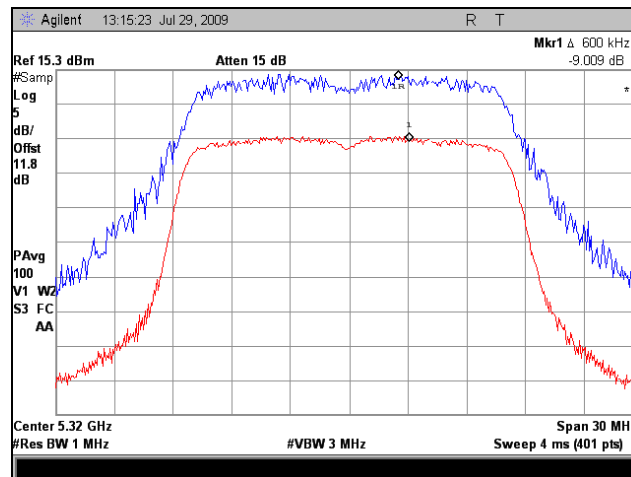

Plot 79. Peak Excursion, Port 1, 802.11a, 5320 MHz

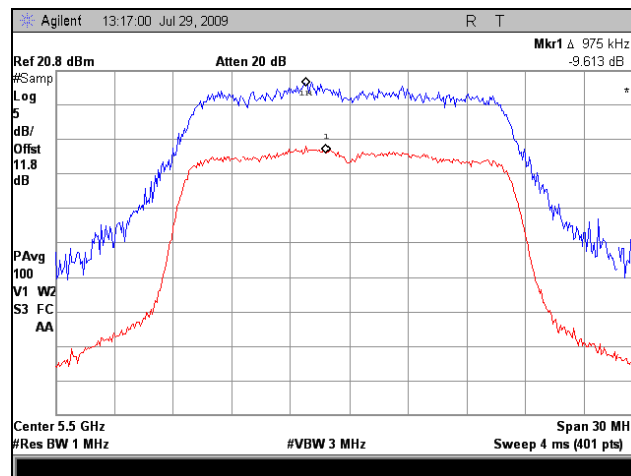

Plot 80. Peak Excursion, Port 1, 802.11a, 5500 MHz

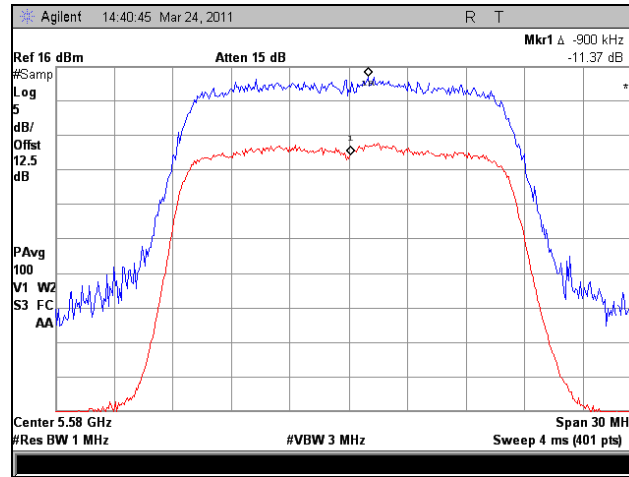

Plot 81. Peak Excursion, Port 1, 802.11a, 5580 MHz

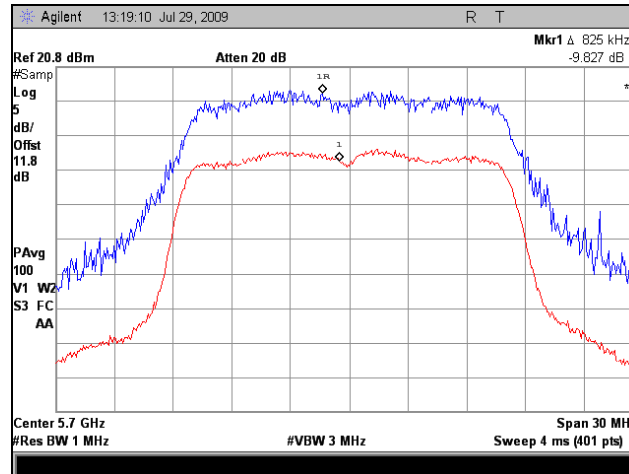

Plot 82. Peak Excursion, Port 1, 802.11a, 5700 MHz

Peak Excursion Ratio, 7200 Outdoor, Port 1, 802.11n 20MHz

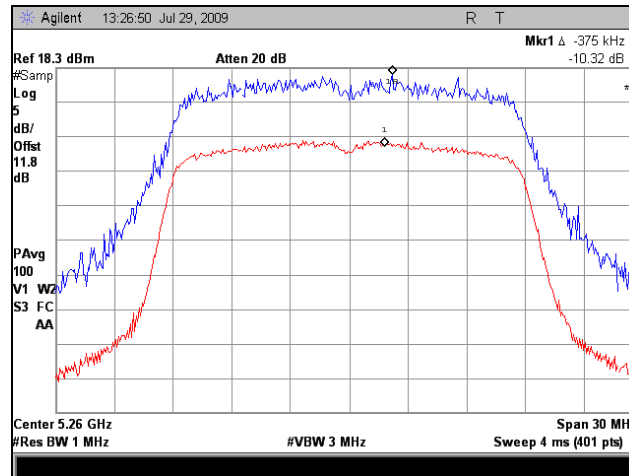

Plot 83. Peak Excursion, Port 1, 802.11n 20MHz, 5260 MHz

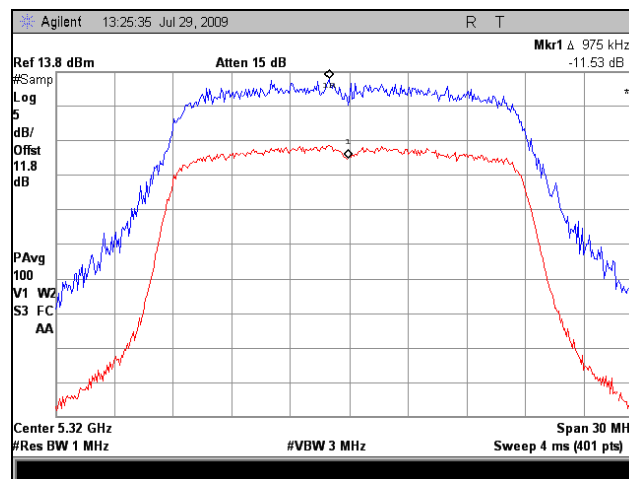

Plot 84. Peak Excursion, Port 1, 802.11n 20MHz, 5320 MHz

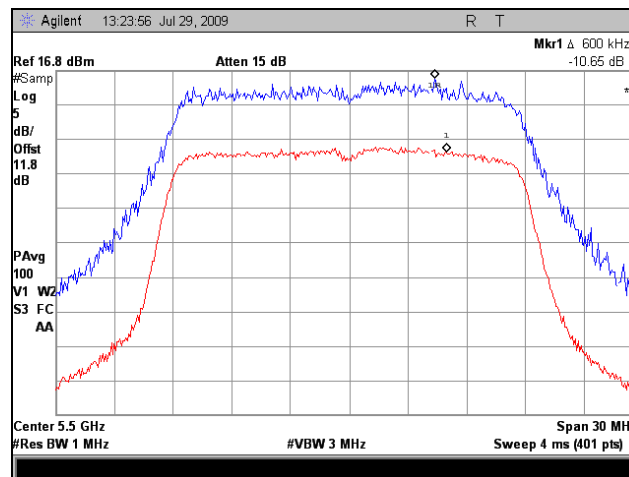

Plot 85. Peak Excursion, Port 1, 802.11n 20MHz, 5500 MHz

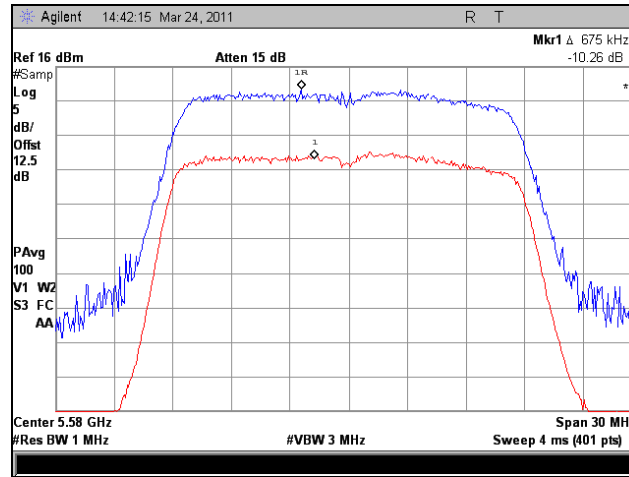

Plot 86. Peak Excursion, Port 1, 802.11n 20MHz, 5580 MHz

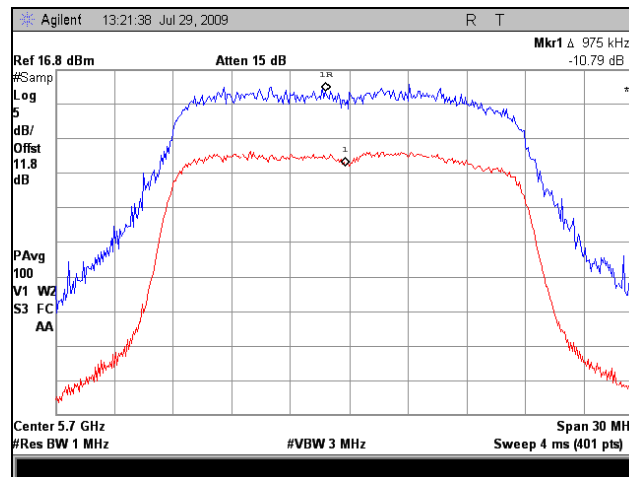

Plot 87. Peak Excursion, Port 1, 802.11n 20MHz, 5700 MHz

Peak Excursion Ratio, Port 1, 802.11n 40MHz

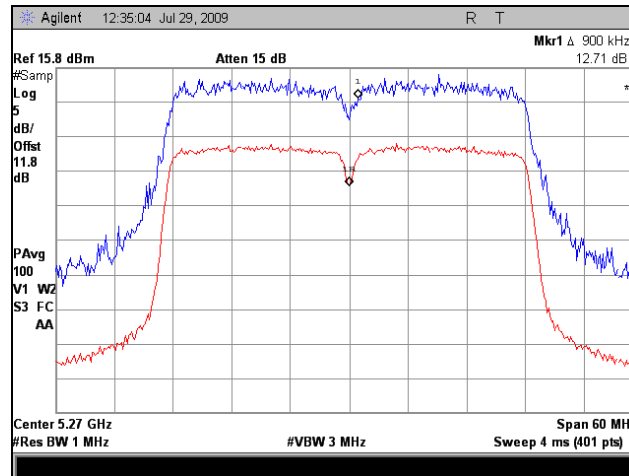

Plot 88. Peak Excursion, Port 1, 802.11n 40MHz, 5270 MHz

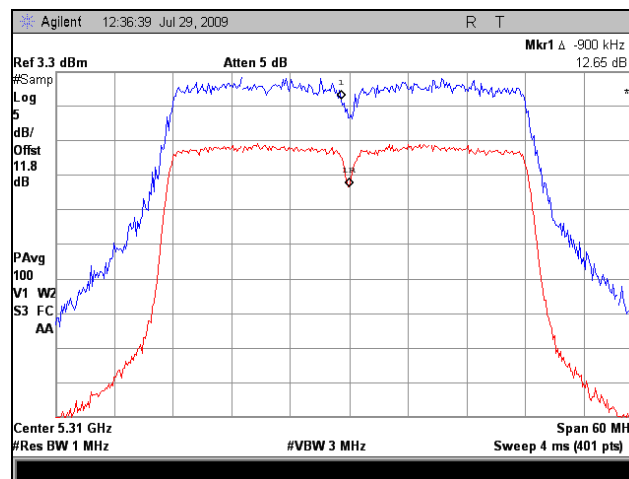

Plot 89. Peak Excursion, Port 1, 802.11n 40MHz, 5310 MHz

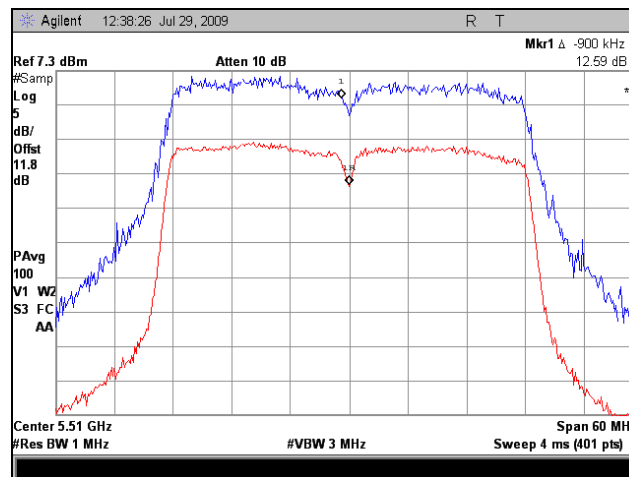

Plot 90. Peak Excursion, Port 1, 802.11n 40MHz, 5510 MHz

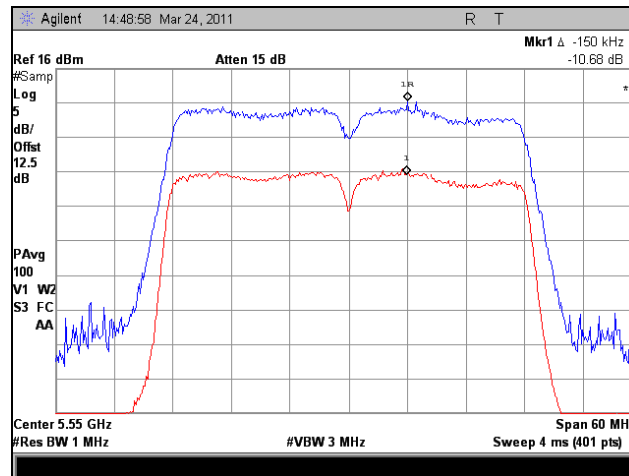

Plot 91. Peak Excursion, Port 1, 802.11n 40MHz, 5550 MHz

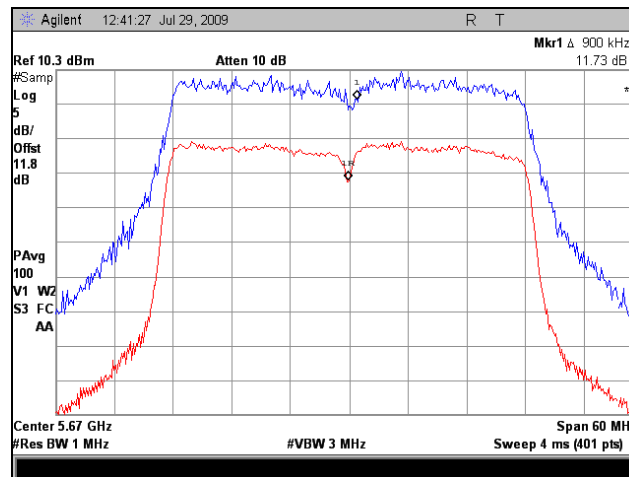

Plot 92. Peak Excursion Ratio, Port 1, 802.11n 40MHz, 5670 MHz

Peak Excursion Ratio, Port 2, 802.11n 20MHz

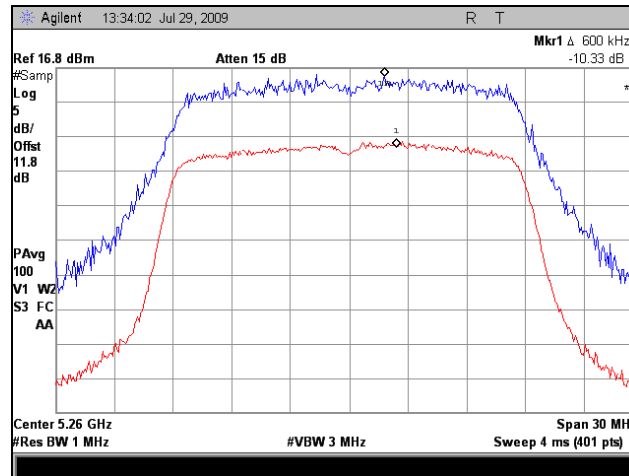

Plot 93. Peak Excursion, Port 2, 802.11n 20MHz, 5260 MHz

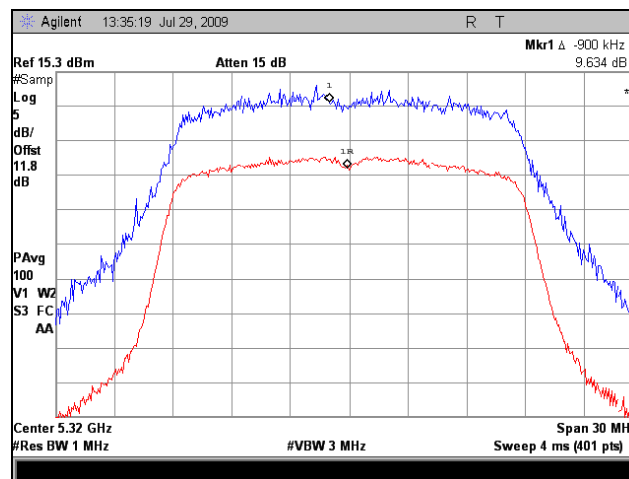

Plot 94. Peak Excursion, Port 2, 802.11n 20MHz, 5320 MHz

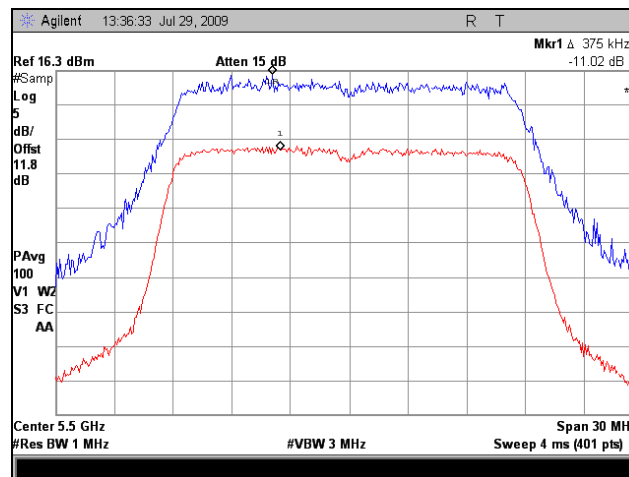

Plot 95. Peak Excursion, Port 2, 802.11n 20MHz, 5500 MHz

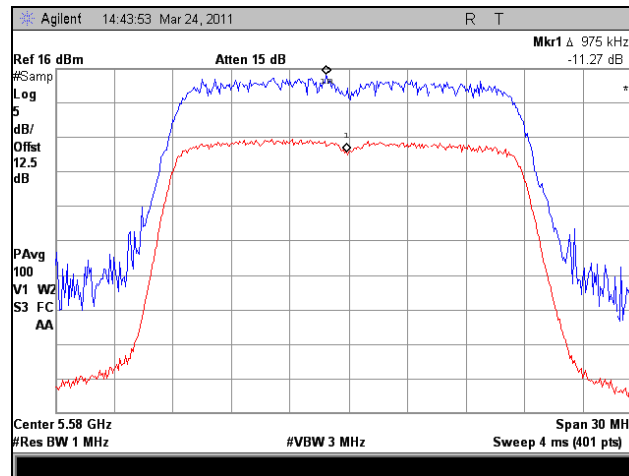

Plot 96. Peak Excursion, Port 2, 802.11n 20MHz, 5580 MHz

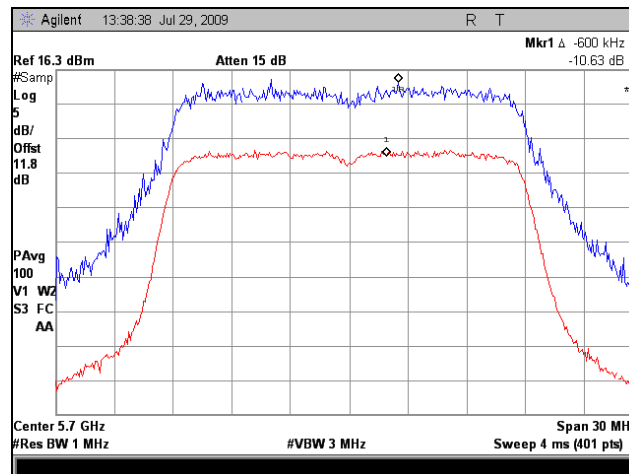

Plot 97. Peak Excursion Ratio, Port 2, 802.11n 20MHz, 5700 MHz

Peak Excursion Ratio, Port 2, 802.11n 40MHz

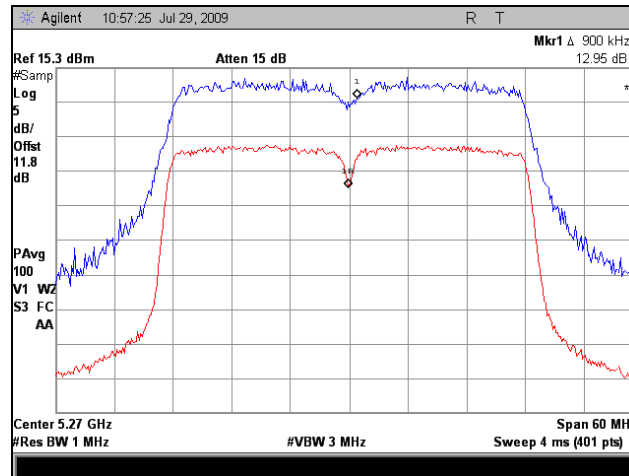

Plot 98. Peak Excursion, Port 2, 802.11n 40MHz, 5270 MHz

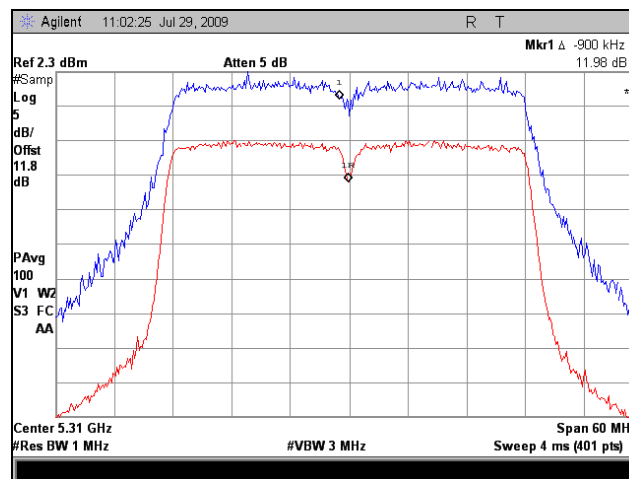

Plot 99. Peak Excursion, Port 2, 802.11n 40MHz, 5310 MHz

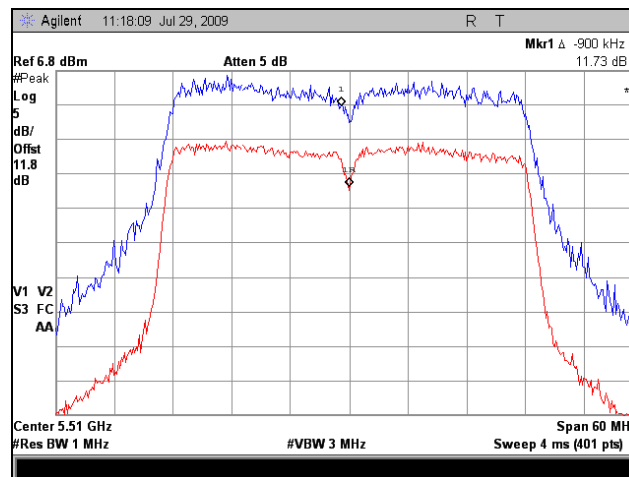

Plot 100. Peak Excursion, Port 2, 802.11n 40MHz, 5510 MHz

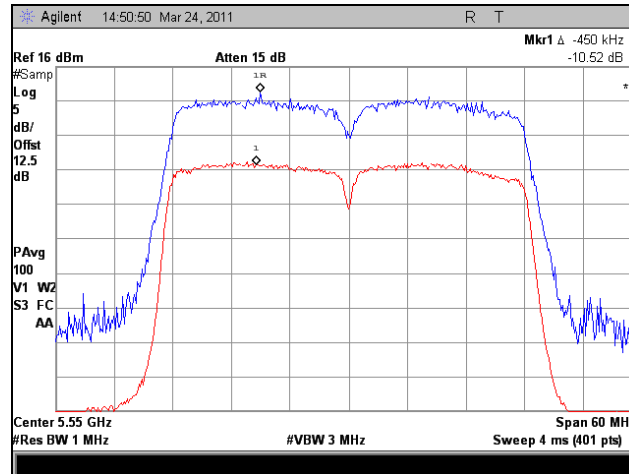

Plot 101. Peak Excursion, Port 2, 802.11n 40MHz, 5550 MHz

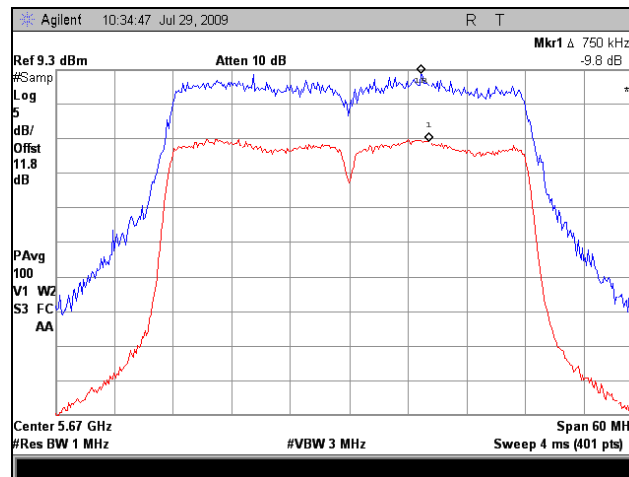

Plot 102. Peak Excursion, Port 2, 802.11n 40MHz, 5670 MHz

Peak Excursion Ratio, Port 3, 802.11n 20MHz

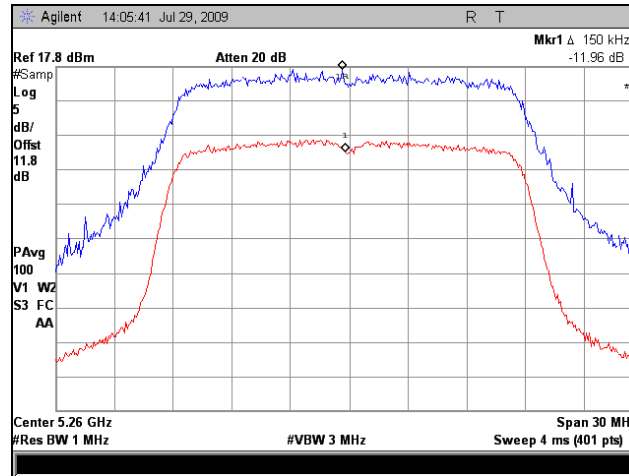

Plot 103. Peak Excursion, Port 3, 802.11n 20MHz, 5260 MHz

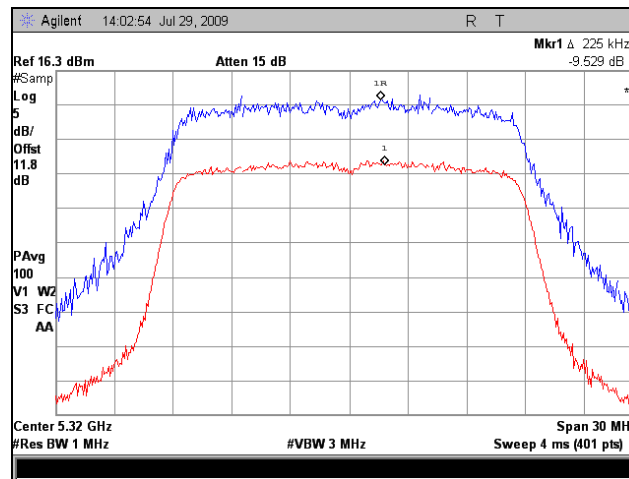

Plot 104. Peak Excursion, Port 3, 802.11n 20MHz, 5320 MHz

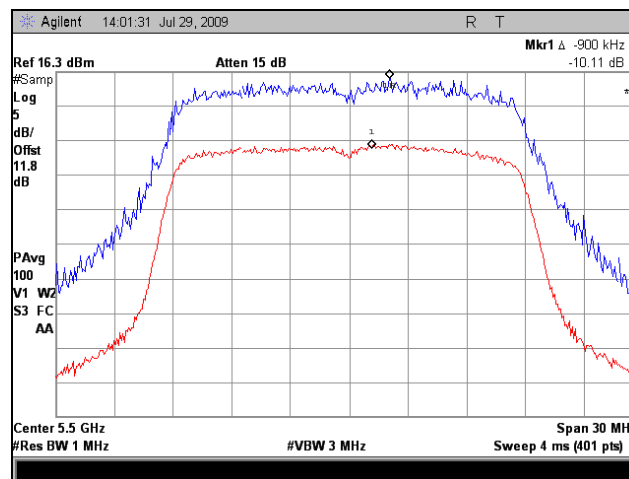

Plot 105. Peak Excursion, Port 3, 802.11n 20MHz, 5500 MHz

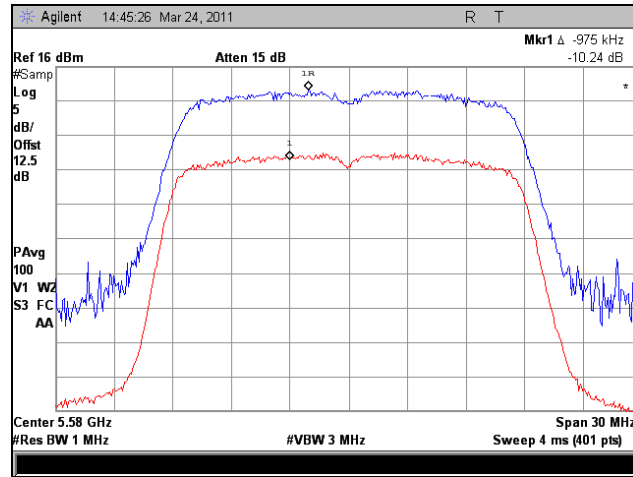

Plot 106. Peak Excursion, Port 3, 802.11n 20MHz, 5580 MHz

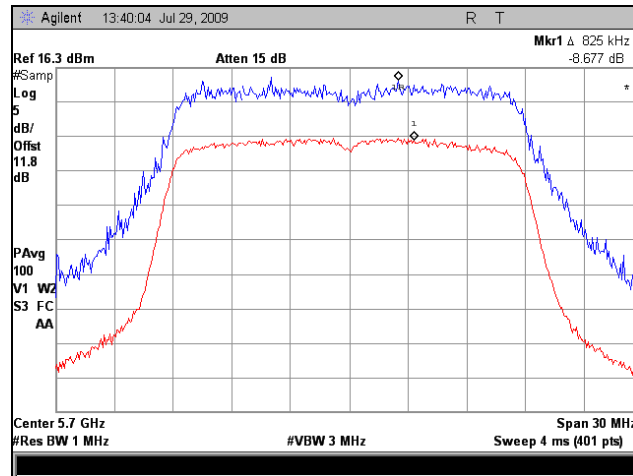

Plot 107. Peak Excursion Ratio, Port 3, 802.11n 20MHz, 5700 MHz

Peak Excursion Ratio, Port 3, 802.11n 40MHz

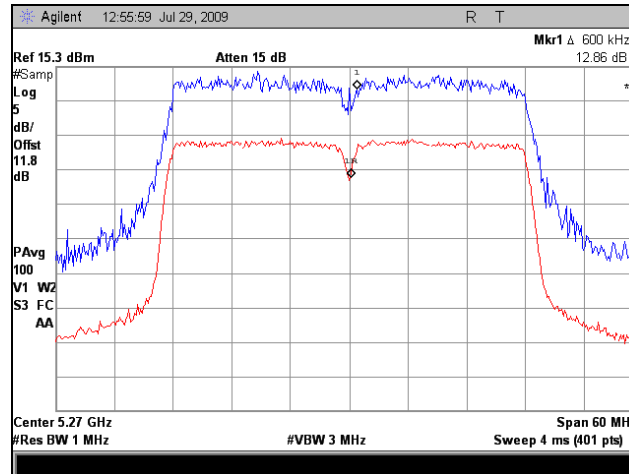

Plot 108. Peak Excursion, Port 3, 802.11n 40MHz, 5270 MHz

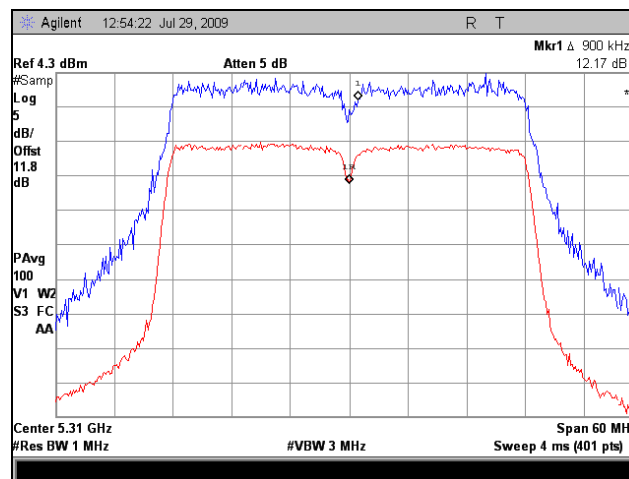

Plot 109. Peak Excursion, Port 3, 802.11n 40MHz, 5310 MHz

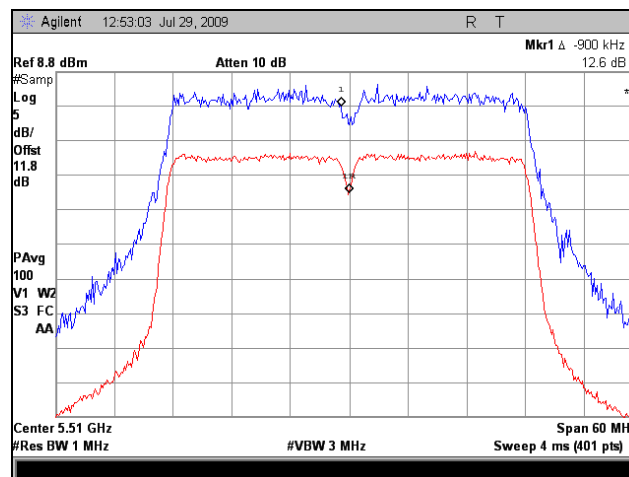

Plot 110. Peak Excursion, Port 3, 802.11n 40MHz, 5510 MHz

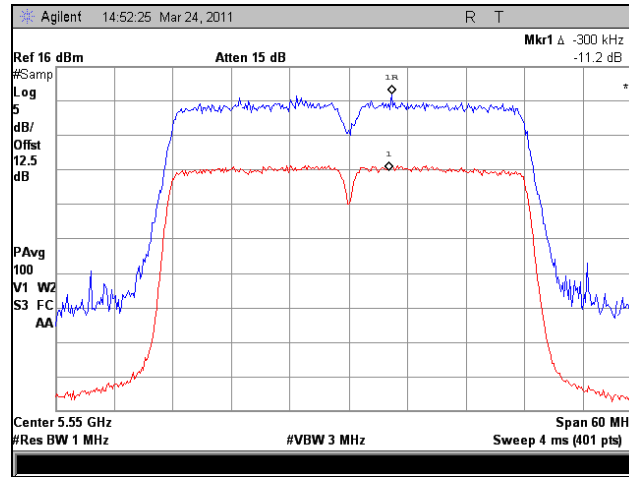

Plot 111. Peak Excursion, Port 3, 802.11n 40MHz, 5550 MHz

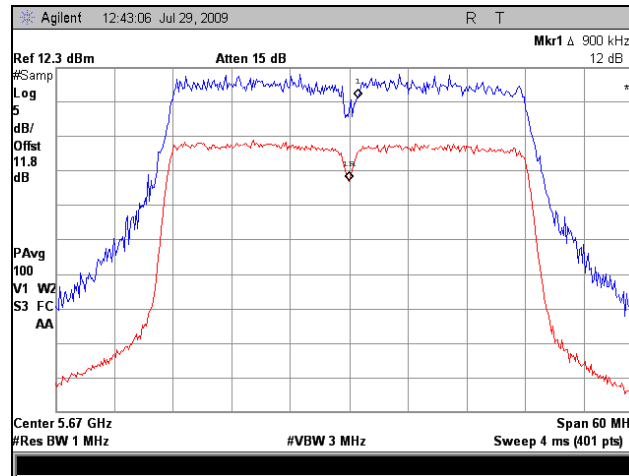

Plot 112. Peak Excursion, Port 3, 802.11n 40MHz, 5670 MHz

Electromagnetic Compatibility Criteria for Intentional Radiators

§ 15.407(b)(1),(2), (5), (6) Undesirable Emissions

Test Requirements: § 15.407(b)(1),(2), (5), (6); §15.205: Emissions outside the frequency band.

§ 15.407(b)(1): In any 1MHz bandwidth outside the frequency band 5.15-5.25GHz in which the spread spectrum or digitally modulated intentional radiator is operating, the radio frequency power shall not exceed -27dBm.

§ 15.407(b)(2): In any 1MHz bandwidth outside the frequency band 5.25-5.35GHz in which the spread spectrum or digitally modulated intentional radiator is operating, the radio frequency power shall not exceed -27dBm.

§ 15.407(b)(6): Radiated emissions which fall in the restricted bands, as defined in § 15.205(a), must also comply with the radiated emission limits specified in § 15.209(a).

§15.205(a): Except as shown in paragraph (d) of this section, only spurious emissions are permitted in any of the frequency bands listed below:

MHz	MHz	MHz	GHz
0.090–0.110-----	16.42–16.423	399.9–410	4.5–5.15
¹ 0.495–0.505-----	16.69475–16.69525	608–614	5.35–5.46
2.1735–2.1905-----	16.80425–16.80475	960–1240	7.25–7.75
4.125–4.128-----	25.5–25.67	1300–1427	8.025–8.5
4.17725–4.17775-----	37.5–38.25	1435–1626.5	9.0–9.2
4.20725–4.20775-----	73–74.6	1645.5–1646.5	9.3–9.5
6.215–6.218-----	74.8–75.2	1660–1710	10.6–12.7
6.26775–6.26825-----	108–121.94	1718.8–1722.2	13.25–13.4
6.31175–6.31225-----	123–138	2200–2300	14.47–14.5
8.291–8.294-----	149.9–150.05	2310–2390	15.35–16.2
8.362–8.366-----	156.52475–156.52525	2483.5–2500	17.7–21.4
8.37625–8.38675-----	156.7–156.9	2655–2900	22.01–23.12
8.41425–8.41475-----	162.0125–167.17	3260–3267	23.6–24.0
12.29–12.293-----	167.72–173.2	3332–3339	31.2–31.8
12.51975–12.52025-----	240–285	3345.8–3358 36.	43–36.5
12.57675–12.57725-----	322–335.4	3600–4400	(²)

Table 26. Restricted Bands of Operation

Test Procedure: The EUT was installed placed on a 0.8m-high wooden table inside a semi-anechoic chamber. The harmonic frequencies the carriers were recorded for reference for final measurements. A receiving horn antenna was placed 3m away from the EUT. Unless otherwise specified, measurements were made using 1MHz RBW & 1MHz VBW for peak measurements and 1MHz RBW & 10Hz VBW for average measurements on a spectrum analyzer.

For each harmonic of the carrier frequency, the turntable was rotated, the positions of the interface cables were varied, and the antenna height was varied between 1 m and 4 m, in order to find the maximum radiated emissions.

The equipment isotropic radiated power (EIRP) at -27dBm/MHz was converted to field strength at 68.23dBuV/m. At the band edge of each band, the EIRP energy measurement is integrated to show the total power over 1MHz.

Test Results: The EUT was found compliant with the requirement(s) of this section. Measured emissions were below applicable limits.

Test Engineer(s): Minh Ly

Test Date(s): 07/28/09 - 08/11/09

Electromagnetic Compatibility Criteria for Intentional Radiators

Harmonic Emissions Requirements – Radiated, 802.11a, (9dBi Omni Antenna)

Freq. (GHz)	Antenna Polarity (H/V)	Raw Amp. @ 3 m (Peak) / (Avg.)	P. Amp. (dB)	Ant. Cor. Factor (dB/m)	Cable Loss (dB)	EUT Field Strength Final Amp. (dBuV/m)	Limit Detector Peak / Avg. (Peak) / (Avg.)	Limit @ 3 m (dBuV/m)	Delta (dB)
10.52	V	45.77	35.19	38.21	6.84	55.63	Peak	74	-18.37
10.52	V	33.41	35.19	38.21	6.84	43.27	Avg.	54	-10.73
15.78	V	44.97	34.97	37.68	8.86	56.55	Peak	74	-17.45
15.78	V	32..41	34.97	37.68	8.86	43.99	Avg.	54	-10.01

Table 27. Radiated Harmonics, 802.11a, 9 dBi Omni, 5260 MHz

Note: All other emissions were measured at the noise floor of the spectrum analyzer.

Freq. (GHz)	Antenna Polarity (H/V)	Raw Amp. @ 3 m (Peak) / (Avg.)	P. Amp. (dB)	Ant. Cor. Factor (dB/m)	Cable Loss (dB)	EUT Field Strength Final Amp. (dBuV/m)	Limit Detector Peak / Avg. (Peak) / (Avg.)	Limit @ 3 m (dBuV/m)	Delta (dB)
10.64	V	50.07	35.03	38.29	6.83	60.16	Peak	74	-13.84
10.64	V	39.24	35.03	38.29	6.83	49.33	Avg.	54	-4.67
15.96	V	44.3	35.09	37.68	8.87	55.76	Peak	74	-18.24
15.96	V	31.43	35.09	37.68	8.87	42.89	Avg.	54	-11.11

Table 28. Radiated Harmonics, 802.11a, 9 dBi Omni, 5320 MHz

Note: All other emissions were measured at the noise floor of the spectrum analyzer.

Harmonic Emissions Requirements – Radiated, 802.11a (9dBi Omni Antenna)

Freq. (GHz)	Antenna Polarity (H/V)	Raw Amp. @ 3 m (Peak) / (Avg.)	P. Amp. (dB)	Ant. Cor. Factor (dB/m)	Cable Loss (dB)	EUT Field Strength Final Amp. (dBuV/m)	Limit Detector Peak / Avg. (Peak) / (Avg.)	Limit @ 3 m (dBuV/m)	Delta (dB)
11	V	44.41	34.81	38.70	6.98	55.28	Peak	74	-18.72
11	V	30.33	34.81	38.70	6.98	41.20	Avg.	54	-12.80
16.5	V	44.61	34.60	38.80	9.70	58.51	Peak	74	-15.49
16.5	V	30.91	34.60	38.80	9.70	44.81	Avg.	54	-9.19

Table 29. Radiated Harmonics, 802.11a, 9 dBi Omni, 5500 MHz

Note: All other emissions were measured at the noise floor of the spectrum analyzer.

Freq. (GHz)	Antenna Polarity (H/V)	Raw Amp. @ 3 m (Peak) / (Avg.)	P. Amp. (dB)	Ant. Cor. Factor (dB/m)	Cable Loss (dB)	EUT Field Strength Final Amp. (dBuV/m)	Limit Detector Peak / Avg. (Peak) / (Avg.)	Limit @ 3 m (dBuV/m)	Delta (dB)
11.16	V	45.41	34.76	39.14	7.30	57.09	Peak	74	-16.91
11.16	V	30.38	34.76	39.14	7.30	42.06	Avg.	54	-11.94
16.74	V	45.04	34.36	40.73	9.66	61.07	Peak	74	-12.93
16.74	V	30.75	34.36	40.73	9.66	46.78	Avg.	54	-7.22

Table 30. Radiated Harmonics, 802.11a, 9 dBi Omni, 5580 MHz

Note: All other emissions were measured at the noise floor of the spectrum analyzer.

Freq. (GHz)	Antenna Polarity (H/V)	Raw Amp. @ 3 m (Peak) / (Avg.)	P. Amp. (dB)	Ant. Cor. Factor (dB/m)	Cable Loss (dB)	EUT Field Strength Final Amp. (dBuV/m)	Limit Detector Peak / Avg. (Peak) / (Avg.)	Limit @ 3 m (dBuV/m)	Delta (dB)
11.4	V	43.41	34.81	39.63	7.63	55.86	Peak	74	-18.14
11.4	V	33.27	34.81	39.63	7.63	45.72	Avg.	54	-8.28
17.1	V	44.7	34.15	42.41	9.77	62.73	Peak	74	-11.27
17.1	V	30.18	34.15	42.41	9.77	48.21	Avg.	54	-5.79

Table 31. Radiated Harmonics, 802.11a, 9 dBi Omni, 5700 MHz

Note: All other emissions were measured at the noise floor of the spectrum analyzer.

Harmonic Emissions Requirements – Radiated, 802.11a (16dBi Sector Antenna)

Freq. (GHz)	Antenna Polarity (H/V)	Raw Amp. @ 3 m (Peak) / (Avg.)	P. Amp. (dB)	Ant. Cor. Factor (dB/m)	Cable Loss (dB)	EUT Field Strength Final Amp. (dBuV/m)	Limit Detector Peak / Avg. (Peak) / (Avg.)	Limit @ 3 m (dBuV/m)	Delta (dB)
10.52	V	44.46	35.19	38.21	6.84	54.32	Peak	74	-19.68
10.52	V	31.24	35.19	38.21	6.84	41.10	Avg.	54	-12.90
15.78	V	45.09	34.97	37.68	8.86	56.67	Peak	74	-17.33
15.78	V	32.22	34.97	37.68	8.86	43.80	Avg.	54	-10.20

Table 32. Radiated Harmonics, 802.11a, 16 dBi Sector, 5260 MHz

Note: All other emissions were measured at the noise floor of the spectrum analyzer.

Freq. (GHz)	Antenna Polarity (H/V)	Raw Amp. @ 3 m (Peak) / (Avg.)	P. Amp. (dB)	Ant. Cor. Factor (dB/m)	Cable Loss (dB)	EUT Field Strength Final Amp. (dBuV/m)	Limit Detector Peak / Avg. (Peak) / (Avg.)	Limit @ 3 m (dBuV/m)	Delta (dB)
10.64	V	48.24	35.03	38.29	6.83	58.33	Peak	74	-15.67
10.64	V	31.04	35.03	38.29	6.83	41.13	Avg.	54	-12.87
15.96	V	46.02	35.09	37.68	8.87	57.48	Peak	74	-16.52
15.96	V	31.75	35.09	37.68	8.87	43.21	Avg.	54	-10.79

Table 33. Radiated Harmonics, 802.11a, 16 dBi Sector, 5320 MHz

Note: All other emissions were measured at the noise floor of the spectrum analyzer.

Harmonic Emissions Requirements – Radiated, 802.11a (16dBi Sector Antenna)

Freq. (GHz)	Antenna Polarity (H/V)	Raw Amp. @ 3 m (Peak) / (Avg.)	P. Amp. (dB)	Ant. Cor. Factor (dB/m)	Cable Loss (dB)	EUT Field Strength Final Amp. (dBuV/m)	Limit Detector Peak / Avg. (Peak) / (Avg.)	Limit @ 3 m (dBuV/m)	Delta (dB)
11	V	45.84	34.81	38.70	6.98	56.71	Peak	74	-17.29
11	V	31.52	34.81	38.70	6.98	42.39	Avg.	54	-11.61
16.5	V	47.38	34.60	38.80	9.70	61.28	Peak	74	-12.72
16.5	V	31.4	34.60	38.80	9.70	45.30	Avg.	54	-8.70

Table 34. Radiated Harmonics, 802.11a, 16 dBi Sector, 5500 MHz

Note: All other emissions were measured at the noise floor of the spectrum analyzer.

Freq. (GHz)	Antenna Polarity (H/V)	Raw Amp. @ 3 m (Peak) / (Avg.)	P. Amp. (dB)	Ant. Cor. Factor (dB/m)	Cable Loss (dB)	EUT Field Strength Final Amp. (dBuV/m)	Limit Detector Peak / Avg. (Peak) / (Avg.)	Limit @ 3 m (dBuV/m)	Delta (dB)
11.16	V	44.65	34.76	39.14	7.30	56.33	Peak	74	-17.67
11.16	V	31.22	34.76	39.14	7.30	42.90	Avg.	54	-11.10
16.74	V	43.73	34.36	40.73	9.66	59.76	Peak	74	-14.24
16.74	V	31.2	34.36	40.73	9.66	47.23	Avg.	54	-6.77

Table 35. Radiated Harmonics, 802.11a, 16 dBi Sector, 5580 MHz

Note: All other emissions were measured at the noise floor of the spectrum analyzer.

Freq. (GHz)	Antenna Polarity (H/V)	Raw Amp. @ 3 m (Peak) / (Avg.)	P. Amp. (dB)	Ant. Cor. Factor (dB/m)	Cable Loss (dB)	EUT Field Strength Final Amp. (dBuV/m)	Limit Detector Peak / Avg. (Peak) / (Avg.)	Limit @ 3 m (dBuV/m)	Delta (dB)
11.4	V	47.97	34.81	39.63	7.63	60.42	Peak	74	-13.58
11.4	V	31.92	34.81	39.63	7.63	44.37	Avg.	54	-9.63
17.1	V	45.44	34.15	42.41	9.77	63.47	Peak	74	-10.53
17.1	V	30.72	34.15	42.41	9.77	48.75	Avg.	54	-5.25

Table 36. Radiated Harmonics, 802.11a, 16 dBi Sector, 5700 MHz

Note: All other emissions were measured at the noise floor of the spectrum analyzer.

Harmonic Emissions Requirements – Radiated, 802.11a (19dBi Panel Antenna)

Freq. (GHz)	Antenna Polarity (H/V)	Raw Amp. @ 3 m (Peak) / (Avg.)	P. Amp. (dB)	Ant. Cor. Factor (dB/m)	Cable Loss (dB)	EUT Field Strength Final Amp. (dBuV/m)	Limit Detector Peak / Avg. (Peak) / (Avg.)	Limit @ 3 m (dBuV/m)	Delta (dB)
10.52	V	44.52	35.19	38.21	6.84	54.38	Peak	74	-19.62
10.52	V	30.81	35.19	38.21	6.84	40.67	Avg.	54	-13.33
15.78	V	44.7	34.97	37.68	8.86	56.28	Peak	74	-17.72
15.78	V	32.27	34.97	37.68	8.86	43.85	Avg.	54	-10.15

Table 37. Radiated Harmonics, 802.11a, 19 dBi Panel, 5260 MHz

Note: All other emissions were measured at the noise floor of the spectrum analyzer.

Freq. (GHz)	Antenna Polarity (H/V)	Raw Amp. @ 3 m (Peak) / (Avg.)	P. Amp. (dB)	Ant. Cor. Factor (dB/m)	Cable Loss (dB)	EUT Field Strength Final Amp. (dBuV/m)	Limit Detector Peak / Avg. (Peak) / (Avg.)	Limit @ 3 m (dBuV/m)	Delta (dB)
10.64	V	50	35.03	38.29	6.83	60.09	Peak	74	-13.91
10.64	V	38.06	35.03	38.29	6.83	48.15	Avg.	54	-5.85
15.96	V	44.6	35.09	37.68	8.87	56.06	Peak	74	-17.94
15.96	V	31.77	35.09	37.68	8.87	43.23	Avg.	54	-10.77

Table 38. Radiated Harmonics, 802.11a, 19 dBi Panel, 5320 MHz

Note: All other emissions were measured at the noise floor of the spectrum analyzer.

Harmonic Emissions Requirements – Radiated, 802.11a (19dBi Panel Antenna)

Freq. (GHz)	Antenna Polarity (H/V)	Raw Amp. @ 3 m (Peak) / (Avg.)	P. Amp. (dB)	Ant. Cor. Factor (dB/m)	Cable Loss (dB)	EUT Field Strength Final Amp. (dBuV/m)	Limit Detector Peak / Avg. (Peak) / (Avg.)	Limit @ 3 m (dBuV/m)	Delta (dB)
11	V	43.83	34.81	38.70	6.98	54.70	Peak	74	-19.30
11	V	31.55	34.81	38.70	6.98	42.42	Avg.	54	-11.58
16.5	V	45.44	34.60	38.80	9.70	59.34	Peak	74	-14.66
16.5	V	31.58	34.60	38.80	9.70	45.48	Avg.	54	-8.52

Table 39. Radiated Harmonics, 802.11a, 19 dBi Panel, 5500 MHz

Note: All other emissions were measured at the noise floor of the spectrum analyzer.

Freq. (GHz)	Antenna Polarity (H/V)	Raw Amp. @ 3 m (Peak) / (Avg.)	P. Amp. (dB)	Ant. Cor. Factor (dB/m)	Cable Loss (dB)	EUT Field Strength Final Amp. (dBuV/m)	Limit Detector Peak / Avg. (Peak) / (Avg.)	Limit @ 3 m (dBuV/m)	Delta (dB)
11.16	V	44.48	34.76	39.14	7.30	56.16	Peak	74	-17.84
11.16	V	33.22	34.76	39.14	7.30	44.90	Avg.	54	-9.10
16.74	V	45.56	34.36	40.73	9.66	61.59	Peak	74	-12.41
16.74	V	31.93	34.36	40.73	9.66	47.96	Avg.	54	-6.04

Table 40. Radiated Harmonics, 802.11a, 19 dBi Panel, 5580 MHz

Note: All other emissions were measured at the noise floor of the spectrum analyzer.

Freq. (GHz)	Antenna Polarity (H/V)	Raw Amp. @ 3 m (Peak) / (Avg.)	P. Amp. (dB)	Ant. Cor. Factor (dB/m)	Cable Loss (dB)	EUT Field Strength Final Amp. (dBuV/m)	Limit Detector Peak / Avg. (Peak) / (Avg.)	Limit @ 3 m (dBuV/m)	Delta (dB)
11.4	V	47.42	34.81	39.63	7.63	59.87	Peak	74	-14.13
11.4	V	31.72	34.81	39.63	7.63	44.17	Avg.	54	-9.83
17.1	V	45.42	34.15	42.41	9.77	63.45	Peak	74	-10.55
17.1	V	30.62	34.15	42.41	9.77	48.65	Avg.	54	-5.35

Table 41. Radiated Harmonics, 802.11a, 19 dBi Panel, 5700 MHz

Note: All other emissions were measured at the noise floor of the spectrum analyzer.

Harmonic Emissions Requirements – Radiated, 802.11n 20MHz (9dBi Omni Antenna)

Freq. (GHz)	Antenna Polarity (H/V)	Raw Amp. @ 3 m (Peak) / (Avg.)	P. Amp. (dB)	Ant. Cor. Factor (dB/m)	Cable Loss (dB)	EUT Field Strength Final Amp. (dBuV/m)	Limit Detector Peak / Avg. (Peak) / (Avg.)	Limit @ 3 m (dBuV/m)	Delta (dB)
10.52	V	46.44	35.19	38.21	6.84	56.30	Peak	74	-17.70
10.52	V	31.01	35.19	38.21	6.84	40.87	Avg.	54	-13.13
15.78	V	46.01	34.97	37.68	8.86	57.59	Peak	74	-16.41
15.78	V	32.79	34.97	37.68	8.86	44.37	Avg.	54	-9.63

Table 42. Radiated Harmonics, 802.11n 20MHz, 9 dBi Omni, 5260 MHz

Note: All other emissions were measured at the noise floor of the spectrum analyzer.

Freq. (GHz)	Antenna Polarity (H/V)	Raw Amp. @ 3 m (Peak) / (Avg.)	P. Amp. (dB)	Ant. Cor. Factor (dB/m)	Cable Loss (dB)	EUT Field Strength Final Amp. (dBuV/m)	Limit Detector Peak / Avg. (Peak) / (Avg.)	Limit @ 3 m (dBuV/m)	Delta (dB)
10.64	V	49.96	35.03	38.29	6.83	60.05	Peak	74	-13.95
10.64	V	37.59	35.03	38.29	6.83	47.68	Avg.	54	-6.32
15.96	V	45.23	35.09	37.68	8.87	56.69	Peak	74	-17.31
15.96	V	32.92	35.09	37.68	8.87	44.38	Avg.	54	-9.62

Table 43. Radiated Harmonics, 802.11n 20MHz, 9 dBi Omni, 5320 MHz

Note: All other emissions were measured at the noise floor of the spectrum analyzer.

Harmonic Emissions Requirements – Radiated, 802.11n 20MHz (9dBi Omni Antenna)

Freq. (GHz)	Antenna Polarity (H/V)	Raw Amp. @ 3 m (Peak) / (Avg.)	P. Amp. (dB)	Ant. Cor. Factor (dB/m)	Cable Loss (dB)	EUT Field Strength Final Amp. (dBuV/m)	Limit Detector Peak / Avg. (Peak) / (Avg.)	Limit @ 3 m (dBuV/m)	Delta (dB)
11	V	44.05	34.81	38.70	6.98	54.92	Peak	74	-19.08
11	V	31.19	34.81	38.70	6.98	42.06	Avg.	54	-11.94
16.5	V	45.88	34.60	38.80	9.70	59.78	Peak	74	-14.22
16.5	V	30.84	34.60	38.80	9.70	44.74	Avg.	54	-9.26

Table 44. Radiated Harmonics, 802.11n 20MHz, 9 dBi Omni, 5500 MHz

Note: All other emissions were measured at the noise floor of the spectrum analyzer.

Freq. (GHz)	Antenna Polarity (H/V)	Raw Amp. @ 3 m (Peak) / (Avg.)	P. Amp. (dB)	Ant. Cor. Factor (dB/m)	Cable Loss (dB)	EUT Field Strength Final Amp. (dBuV/m)	Limit Detector Peak / Avg. (Peak) / (Avg.)	Limit @ 3 m (dBuV/m)	Delta (dB)
11.16	V	45.1	34.76	39.14	7.30	56.78	Peak	74	-17.22
11.16	V	30.04	34.76	39.14	7.30	41.72	Avg.	54	-12.28
16.74	V	44.39	34.36	40.73	9.66	60.42	Peak	74	-13.58
16.74	V	32.24	34.36	40.73	9.66	48.27	Avg.	54	-5.73

Table 45. Radiated Harmonics, 802.11n 20MHz, 9 dBi Omni, 5580 MHz

Note: All other emissions were measured at the noise floor of the spectrum analyzer.

Freq. (GHz)	Antenna Polarity (H/V)	Raw Amp. @ 3 m (Peak) / (Avg.)	P. Amp. (dB)	Ant. Cor. Factor (dB/m)	Cable Loss (dB)	EUT Field Strength Final Amp. (dBuV/m)	Limit Detector Peak / Avg. (Peak) / (Avg.)	Limit @ 3 m (dBuV/m)	Delta (dB)
11.4	V	46.04	34.81	39.63	7.63	58.49	Peak	74	-15.51
11.4	V	31.76	34.81	39.63	7.63	44.21	Avg.	54	-9.79
17.1	V	44.71	34.15	42.41	9.77	62.74	Peak	74	-11.26
17.1	V	32.72	34.15	42.41	9.77	50.75	Avg.	54	-3.25

Table 46. Radiated Harmonics, 802.11n 20MHz, 9 dBi Omni, 5700 MHz

Note: All other emissions were measured at the noise floor of the spectrum analyzer.

Harmonic Emissions Requirements – Radiated, 802.11n 20MHz (16dBi Sector Antenna)

Freq. (GHz)	Antenna Polarity (H/V)	Raw Amp. @ 3 m (Peak) / (Avg.)	P. Amp. (dB)	Ant. Cor. Factor (dB/m)	Cable Loss (dB)	EUT Field Strength Final Amp. (dBuV/m)	Limit Detector Peak / Avg. (Peak) / (Avg.)	Limit @ 3 m (dBuV/m)	Delta (dB)
10.52	V	46.65	35.19	38.21	6.84	56.51	Peak	74	-17.49
10.52	V	31.28	35.19	38.21	6.84	41.14	Avg.	54	-12.86
15.78	V	44.99	34.97	37.68	8.86	56.57	Peak	74	-17.43
15.78	V	32.09	34.97	37.68	8.86	43.67	Avg.	54	-10.33

Table 47. Radiated Harmonics, 802.11n 20MHz, 16 dBi Sector, 5260 MHz

Note: All other emissions were measured at the noise floor of the spectrum analyzer.

Freq. (GHz)	Antenna Polarity (H/V)	Raw Amp. @ 3 m (Peak) / (Avg.)	P. Amp. (dB)	Ant. Cor. Factor (dB/m)	Cable Loss (dB)	EUT Field Strength Final Amp. (dBuV/m)	Limit Detector Peak / Avg. (Peak) / (Avg.)	Limit @ 3 m (dBuV/m)	Delta (dB)
10.64	V	49.72	35.03	38.29	6.83	59.81	Peak	74	-14.19
10.64	V	31.84	35.03	38.29	6.83	41.93	Avg.	54	-12.07
15.96	V	44.69	35.09	37.68	8.87	56.15	Peak	74	-17.85
15.96	V	31.9	35.09	37.68	8.87	43.36	Avg.	54	-10.64

Table 48. Radiated Harmonics, 802.11n 20MHz, 16 dBi Sector, 5320 MHz

Note: All other emissions were measured at the noise floor of the spectrum analyzer.

Harmonic Emissions Requirements – Radiated, 802.11n 20MHz (16dBi Sector Antenna)

Freq. (GHz)	Antenna Polarity (H/V)	Raw Amp. @ 3 m (Peak) / (Avg.)	P. Amp. (dB)	Ant. Cor. Factor (dB/m)	Cable Loss (dB)	EUT Field Strength Final Amp. (dBuV/m)	Limit Detector Peak / Avg. (Peak) / (Avg.)	Limit @ 3 m (dBuV/m)	Delta (dB)
11	V	47.2	34.81	38.70	6.98	58.07	Peak	74	-15.93
11	V	32.23	34.81	38.70	6.98	43.10	Avg.	54	-10.90
16.5	V	45.86	34.60	38.80	9.70	59.76	Peak	74	-14.24
16.5	V	31.59	34.60	38.80	9.70	45.49	Avg.	54	-8.51

Table 49. Radiated Harmonics, 802.11n 20MHz, 16 dBi Sector, 5500 MHz

Note: All other emissions were measured at the noise floor of the spectrum analyzer.

Freq. (GHz)	Antenna Polarity (H/V)	Raw Amp. @ 3 m (Peak) / (Avg.)	P. Amp. (dB)	Ant. Cor. Factor (dB/m)	Cable Loss (dB)	EUT Field Strength Final Amp. (dBuV/m)	Limit Detector Peak / Avg. (Peak) / (Avg.)	Limit @ 3 m (dBuV/m)	Delta (dB)
11.16	V	45.21	34.76	39.14	7.30	56.89	Peak	74	-17.11
11.16	V	31.73	34.76	39.14	7.30	43.41	Avg.	54	-10.59
16.74	V	44.38	34.36	40.73	9.66	60.41	Peak	74	-13.59
16.74	V	31.23	34.36	40.73	9.66	47.26	Avg.	54	-6.74

Table 50. Radiated Harmonics, 802.11n 20MHz, 16 dBi Sector, 5580 MHz

Note: All other emissions were measured at the noise floor of the spectrum analyzer.

Freq. (GHz)	Antenna Polarity (H/V)	Raw Amp. @ 3 m (Peak) / (Avg.)	P. Amp. (dB)	Ant. Cor. Factor (dB/m)	Cable Loss (dB)	EUT Field Strength Final Amp. (dBuV/m)	Limit Detector Peak / Avg. (Peak) / (Avg.)	Limit @ 3 m (dBuV/m)	Delta (dB)
11.4	V	48.56	34.81	39.63	7.63	61.01	Peak	74	-12.99
11.4	V	32.75	34.81	39.63	7.63	45.20	Avg.	54	-8.80
17.1	V	43.15	34.15	42.41	9.77	61.18	Peak	74	-12.82
17.1	V	30.56	34.15	42.41	9.77	48.59	Avg.	54	-5.41

Table 51. Radiated Harmonics, 802.11n 20MHz, 16 dBi Sector, 5700 MHz

Note: All other emissions were measured at the noise floor of the spectrum analyzer.

Harmonic Emissions Requirements – Radiated, 802.11n 20MHz (19dBi Panel Antenna)

Freq. (GHz)	Antenna Polarity (H/V)	Raw Amp. @ 3 m (Peak) / (Avg.)	P. Amp. (dB)	Ant. Cor. Factor (dB/m)	Cable Loss (dB)	EUT Field Strength Final Amp. (dBuV/m)	Limit Detector Peak / Avg. (Peak) / (Avg.)	Limit @ 3 m (dBuV/m)	Delta (dB)
10.52	V	45.37	35.19	38.21	6.84	55.23	Peak	74	-18.77
10.52	V	35.22	35.19	38.21	6.84	45.08	Avg.	54	-8.92
15.78	V	48.09	34.97	37.68	8.86	59.67	Peak	74	-14.33
15.78	V	33.41	34.97	37.68	8.86	44.99	Avg.	54	-9.01

Table 52. Radiated Harmonics, 802.11n 20MHz, 19 dBi Panel, 5260 MHz

Note: All other emissions were measured at the noise floor of the spectrum analyzer.

Freq. (GHz)	Antenna Polarity (H/V)	Raw Amp. @ 3 m (Peak) / (Avg.)	P. Amp. (dB)	Ant. Cor. Factor (dB/m)	Cable Loss (dB)	EUT Field Strength Final Amp. (dBuV/m)	Limit Detector Peak / Avg. (Peak) / (Avg.)	Limit @ 3 m (dBuV/m)	Delta (dB)
10.64	V	48.99	35.03	38.29	6.83	59.08	Peak	74	-14.92
10.64	V	35.77	35.03	38.29	6.83	45.86	Avg.	54	-8.14
15.96	V	44.88	35.09	37.68	8.87	56.34	Peak	74	-17.66
15.96	V	32.98	35.09	37.68	8.87	44.44	Avg.	54	-9.56

Table 53. Radiated Harmonics, 802.11n 20MHz, 19 dBi Panel, 5320 MHz

Note: All other emissions were measured at the noise floor of the spectrum analyzer.

Harmonic Emissions Requirements – Radiated, 802.11n 20MHz (19dBi Panel Antenna)

Freq. (GHz)	Antenna Polarity (H/V)	Raw Amp. @ 3 m (Peak) / (Avg.)	P. Amp. (dB)	Ant. Cor. Factor (dB/m)	Cable Loss (dB)	EUT Field Strength Final Amp. (dBuV/m)	Limit Detector Peak / Avg. (Peak) / (Avg.)	Limit @ 3 m (dBuV/m)	Delta (dB)
11	V	45.93	34.81	38.70	6.98	56.80	Peak	74	-17.20
11	V	30.47	34.81	38.70	6.98	41.34	Avg.	54	-12.66
16.5	V	47.04	34.60	38.80	9.70	60.94	Peak	74	-13.06
16.5	V	35.65	34.60	38.80	9.70	49.55	Avg.	54	-4.45

Table 54. Radiated Harmonics, 802.11n 20MHz, 19 dBi Panel, 5500 MHz

Note: All other emissions were measured at the noise floor of the spectrum analyzer.

Freq. (GHz)	Antenna Polarity (H/V)	Raw Amp. @ 3 m (Peak) / (Avg.)	P. Amp. (dB)	Ant. Cor. Factor (dB/m)	Cable Loss (dB)	EUT Field Strength Final Amp. (dBuV/m)	Limit Detector Peak / Avg. (Peak) / (Avg.)	Limit @ 3 m (dBuV/m)	Delta (dB)
11.16	V	44.29	34.76	39.14	7.30	55.97	Peak	74	-18.03
11.16	V	32.48	34.76	39.14	7.30	44.16	Avg.	54	-9.84
16.74	V	45.49	34.36	40.73	9.66	61.52	Peak	74	-12.48
16.74	V	33.72	34.36	40.73	9.66	49.75	Avg.	54	-4.25

Table 55. Radiated Harmonics, 802.11n 20MHz, 19 dBi Panel, 5580 MHz

Note: All other emissions were measured at the noise floor of the spectrum analyzer.

Freq. (GHz)	Antenna Polarity (H/V)	Raw Amp. @ 3 m (Peak) / (Avg.)	P. Amp. (dB)	Ant. Cor. Factor (dB/m)	Cable Loss (dB)	EUT Field Strength Final Amp. (dBuV/m)	Limit Detector Peak / Avg. (Peak) / (Avg.)	Limit @ 3 m (dBuV/m)	Delta (dB)
11.4	V	45.52	34.81	39.63	7.63	57.97	Peak	74	-16.03
11.4	V	34.2	34.81	39.63	7.63	46.65	Avg.	54	-7.35
17.1	V	45.12	34.15	42.41	9.77	63.15	Peak	74	-10.85
17.1	V	30.63	34.15	42.41	9.77	48.66	Avg.	54	-5.34

Table 56. Radiated Harmonics, 802.11n 20MHz, 19 dBi Panel, 5700 MHz

Note: All other emissions were measured at the noise floor of the spectrum analyzer.

Harmonic Emissions Requirements – Radiated, 802.11n 40MHz (9dBi Omni Antenna)

Freq. (GHz)	Antenna Polarity (H/V)	Raw Amp. @ 3 m (Peak) / (Avg.)	P. Amp. (dB)	Ant. Cor. Factor (dB/m)	Cable Loss (dB)	EUT Field Strength Final Amp. (dBuV/m)	Limit Detector Peak / Avg. (Peak) / (Avg.)	Limit @ 3 m (dBuV/m)	Delta (dB)
10.54	V	44.39	35.16	38.22	6.83	54.28	Peak	74	-19.72
10.54	V	30.52	35.16	38.22	6.83	40.41	Avg.	54	-13.59
15.81	V	45.51	34.99	37.67	8.85	57.05	Peak	74	-16.95
15.81	V	32.39	34.99	37.67	8.85	43.93	Avg.	54	-10.07

Table 57. Radiated Harmonics, 802.11n 40MHz, 9 dBi Omni, 5270 MHz

Note: All other emissions were measured at the noise floor of the spectrum analyzer.

Freq. (GHz)	Antenna Polarity (H/V)	Raw Amp. @ 3 m (Peak) / (Avg.)	P. Amp. (dB)	Ant. Cor. Factor (dB/m)	Cable Loss (dB)	EUT Field Strength Final Amp. (dBuV/m)	Limit Detector Peak / Avg. (Peak) / (Avg.)	Limit @ 3 m (dBuV/m)	Delta (dB)
10.62	V	48.5	35.06	38.27	6.83	58.54	Peak	74	-15.46
10.62	V	34.55	35.06	38.27	6.83	44.59	Avg.	54	-9.41
15.93	V	44.46	35.07	37.67	8.86	55.91	Peak	74	-18.09
15.93	V	32.27	35.07	37.67	8.86	43.72	Avg.	54	-10.28

Table 58. Radiated Harmonics, 802.11n 40MHz, 9 dBi Omni, 5310 MHz

Note: All other emissions were measured at the noise floor of the spectrum analyzer.

Harmonic Emissions Requirements – Radiated, 802.11n 40MHz (9dBi Omni Antenna)

Freq. (GHz)	Antenna Polarity (H/V)	Raw Amp. @ 3 m (Peak) / (Avg.)	P. Amp. (dB)	Ant. Cor. Factor (dB/m)	Cable Loss (dB)	EUT Field Strength Final Amp. (dBuV/m)	Limit Detector Peak / Avg. (Peak) / (Avg.)	Limit @ 3 m (dBuV/m)	Delta (dB)
11.02	V	45.02	34.80	38.73	7.00	55.95	Peak	74	-18.05
11.02	V	31.09	34.80	38.73	7.00	42.02	Avg.	54	-11.98
16.53	V	43.69	34.55	38.94	9.72	57.79	Peak	74	-16.21
16.53	V	30.96	34.55	38.94	9.72	45.06	Avg.	54	-8.94

Table 59. Radiated Harmonics, 802.11n 40MHz, 9 dBi Omni, 5510 MHz

Note: All other emissions were measured at the noise floor of the spectrum analyzer.

Freq. (GHz)	Antenna Polarity (H/V)	Raw Amp. @ 3 m (Peak) / (Avg.)	P. Amp. (dB)	Ant. Cor. Factor (dB/m)	Cable Loss (dB)	EUT Field Strength Final Amp. (dBuV/m)	Limit Detector Peak / Avg. (Peak) / (Avg.)	Limit @ 3 m (dBuV/m)	Delta (dB)
11.1	V	44.27	34.76	39.09	7.26	55.86	Peak	74	-18.14
11.1	V	30.1	34.76	39.09	7.26	41.69	Avg.	54	-12.31
16.65	V	46.58	34.37	40.51	9.67	62.40	Peak	74	-11.60
16.65	V	32.47	34.37	40.51	9.67	48.29	Avg.	54	-5.71

Table 60. Radiated Harmonics, 802.11n 40MHz, 9 dBi Omni, 5550 MHz

Note: All other emissions were measured at the noise floor of the spectrum analyzer.

Freq. (GHz)	Antenna Polarity (H/V)	Raw Amp. @ 3 m (Peak) / (Avg.)	P. Amp. (dB)	Ant. Cor. Factor (dB/m)	Cable Loss (dB)	EUT Field Strength Final Amp. (dBuV/m)	Limit Detector Peak / Avg. (Peak) / (Avg.)	Limit @ 3 m (dBuV/m)	Delta (dB)
11.34	V	44.78	34.78	39.50	7.56	57.05	Peak	74	-16.95
11.34	V	31.98	34.78	39.50	7.56	44.25	Avg.	54	-9.75
17.01	V	43.4	34.24	42.05	9.68	60.89	Peak	74	-13.11
17.01	V	31.11	34.24	42.05	9.68	48.60	Avg.	54	-5.40

Table 61. Radiated Harmonics, 802.11n 40MHz, 9 dBi Omni, 5670 MHz

Note: All other emissions were measured at the noise floor of the spectrum analyzer.

Harmonic Emissions Requirements – Radiated, 802.11n 40MHz (16dBi Sector Antenna)

Freq. (GHz)	Antenna Polarity (H/V)	Raw Amp. @ 3 m (Peak) / (Avg.)	P. Amp. (dB)	Ant. Cor. Factor (dB/m)	Cable Loss (dB)	EUT Field Strength Final Amp. (dBuV/m)	Limit Detector Peak / Avg. (Peak) / (Avg.)	Limit @ 3 m (dBuV/m)	Delta (dB)
10.54	V	46.67	35.16	38.22	6.83	56.56	Peak	74	-17.44
10.54	V	30.73	35.16	38.22	6.83	40.62	Avg.	54	-13.38
15.81	V	44.68	34.99	37.67	8.85	56.22	Peak	74	-17.78
15.81	V	31.99	34.99	37.67	8.85	43.53	Avg.	54	-10.47

Table 62. Radiated Harmonics, 802.11n 40MHz, 16 dBi Sector, 5270 MHz

Note: All other emissions were measured at the noise floor of the spectrum analyzer.

Freq. (GHz)	Antenna Polarity (H/V)	Raw Amp. @ 3 m (Peak) / (Avg.)	P. Amp. (dB)	Ant. Cor. Factor (dB/m)	Cable Loss (dB)	EUT Field Strength Final Amp. (dBuV/m)	Limit Detector Peak / Avg. (Peak) / (Avg.)	Limit @ 3 m (dBuV/m)	Delta (dB)
10.62	V	48.24	35.06	38.27	6.83	58.28	Peak	74	-15.72
10.62	V	31.65	35.06	38.27	6.83	41.69	Avg.	54	-12.31
15.93	V	44.49	35.07	37.67	8.86	55.94	Peak	74	-18.06
15.93	V	31.76	35.07	37.67	8.86	43.21	Avg.	54	-10.79

Table 63. Radiated Harmonics, 802.11n 40MHz, 16 dBi Sector, 5310 MHz

Note: All other emissions were measured at the noise floor of the spectrum analyzer.

Harmonic Emissions Requirements – Radiated, 802.11n 40MHz (16dBi Sector Antenna)

Freq. (GHz)	Antenna Polarity (H/V)	Raw Amp. @ 3 m (Peak) / (Avg.)	P. Amp. (dB)	Ant. Cor. Factor (dB/m)	Cable Loss (dB)	EUT Field Strength Final Amp. (dBuV/m)	Limit Detector Peak / Avg. (Peak) / (Avg.)	Limit @ 3 m (dBuV/m)	Delta (dB)
11.02	V	47.93	34.80	38.73	7.00	58.86	Peak	74	-15.14
11.02	V	31.13	34.80	38.73	7.00	42.06	Avg.	54	-11.94
16.53	V	44.92	34.55	38.94	9.72	59.02	Peak	74	-14.98
16.53	V	32.03	34.55	38.94	9.72	46.13	Avg.	54	-7.87

Table 64. Radiated Harmonics, 802.11n 40MHz, 16 dBi Sector, 5510 MHz

Note: All other emissions were measured at the noise floor of the spectrum analyzer.

Freq. (GHz)	Antenna Polarity (H/V)	Raw Amp. @ 3 m (Peak) / (Avg.)	P. Amp. (dB)	Ant. Cor. Factor (dB/m)	Cable Loss (dB)	EUT Field Strength Final Amp. (dBuV/m)	Limit Detector Peak / Avg. (Peak) / (Avg.)	Limit @ 3 m (dBuV/m)	Delta (dB)
11.1	V	45.12	34.76	39.09	7.26	56.71	Peak	74	-17.29
11.1	V	30.96	34.76	39.09	7.26	42.55	Avg.	54	-11.45
16.65	V	44.05	34.37	40.51	9.67	59.87	Peak	74	-14.13
16.65	V	30.98	34.37	40.51	9.67	46.80	Avg.	54	-7.20

Table 65. Radiated Harmonics, 802.11n 40MHz, 16 dBi Sector, 5550 MHz

Note: All other emissions were measured at the noise floor of the spectrum analyzer.

Freq. (GHz)	Antenna Polarity (H/V)	Raw Amp. @ 3 m (Peak) / (Avg.)	P. Amp. (dB)	Ant. Cor. Factor (dB/m)	Cable Loss (dB)	EUT Field Strength Final Amp. (dBuV/m)	Limit Detector Peak / Avg. (Peak) / (Avg.)	Limit @ 3 m (dBuV/m)	Delta (dB)
11.34	V	44.19	34.78	39.50	7.56	56.46	Peak	74	-17.54
11.34	V	31.52	34.78	39.50	7.56	43.79	Avg.	54	-10.21
17.01	V	43.67	34.24	42.05	9.68	61.16	Peak	74	-12.84
17.01	V	31.24	34.24	42.05	9.68	48.73	Avg.	54	-5.27

Table 66. Radiated Harmonics, 802.11n 40MHz, 16 dBi Sector, 5670 MHz

Note: All other emissions were measured at the noise floor of the spectrum analyzer.

Harmonic Emissions Requirements – Radiated, 802.11n 40MHz (19dBi Panel Antenna)

Freq. (GHz)	Antenna Polarity (H/V)	Raw Amp. @ 3 m (Peak) / (Avg.)	P. Amp. (dB)	Ant. Cor. Factor (dB/m)	Cable Loss (dB)	EUT Field Strength Final Amp. (dBuV/m)	Limit Detector Peak / Avg. (Peak) / (Avg.)	Limit @ 3 m (dBuV/m)	Delta (dB)
10.54	V	44.29	35.16	38.22	6.83	54.18	Peak	74	-19.82
10.54	V	34.06	35.16	38.22	6.83	43.95	Avg.	54	-10.05
15.81	V	45.29	34.99	37.67	8.85	56.83	Peak	74	-17.17
15.81	V	32.3	34.99	37.67	8.85	43.84	Avg.	54	-10.16

Table 67. Radiated Harmonics, 802.11n 40MHz, 19 dBi Panel, 5270 MHz

Note: All other emissions were measured at the noise floor of the spectrum analyzer.

Freq. (GHz)	Antenna Polarity (H/V)	Raw Amp. @ 3 m (Peak) / (Avg.)	P. Amp. (dB)	Ant. Cor. Factor (dB/m)	Cable Loss (dB)	EUT Field Strength Final Amp. (dBuV/m)	Limit Detector Peak / Avg. (Peak) / (Avg.)	Limit @ 3 m (dBuV/m)	Delta (dB)
10.62	V	47.11	35.06	38.27	6.83	57.15	Peak	74	-16.85
10.62	V	34.53	35.06	38.27	6.83	44.57	Avg.	54	-9.43
15.93	V	44.63	35.07	37.67	8.86	56.08	Peak	74	-17.92
15.93	V	31.72	35.07	37.67	8.86	43.17	Avg.	54	-10.83

Table 68. Radiated Harmonics, 802.11n 40MHz, 19 dBi Panel, 5310 MHz

Note: All other emissions were measured at the noise floor of the spectrum analyzer.

Harmonic Emissions Requirements – Radiated, 802.11n 40MHz (19dBi Panel Antenna)

Freq. (GHz)	Antenna Polarity (H/V)	Raw Amp. @ 3 m (Peak) / (Avg.)	P. Amp. (dB)	Ant. Cor. Factor (dB/m)	Cable Loss (dB)	EUT Field Strength Final Amp. (dBuV/m)	Limit Detector Peak / Avg. (Peak) / (Avg.)	Limit @ 3 m (dBuV/m)	Delta (dB)
11.02	V	43.13	34.80	38.73	7.00	54.06	Peak	74	-19.94
11.02	V	30.57	34.80	38.73	7.00	41.50	Avg.	54	-12.50
16.53	V	43.63	34.55	38.94	9.72	57.73	Peak	74	-16.27
16.53	V	31.37	34.55	38.94	9.72	45.47	Avg.	54	-8.53

Table 69. Radiated Harmonics, 802.11n 40MHz, 19 dBi Panel, 5510 MHz

Note: All other emissions were measured at the noise floor of the spectrum analyzer.

Freq. (GHz)	Antenna Polarity (H/V)	Raw Amp. @ 3 m (Peak) / (Avg.)	P. Amp. (dB)	Ant. Cor. Factor (dB/m)	Cable Loss (dB)	EUT Field Strength Final Amp. (dBuV/m)	Limit Detector Peak / Avg. (Peak) / (Avg.)	Limit @ 3 m (dBuV/m)	Delta (dB)
11.1	V	44.71	34.76	39.09	7.26	56.30	Peak	74	-17.70
11.1	V	30.91	34.76	39.09	7.26	42.50	Avg.	54	-11.50
16.65	V	43.91	34.37	40.51	9.67	59.73	Peak	74	-14.27
16.65	V	31.58	34.37	40.51	9.67	47.40	Avg.	54	-6.60

Table 70. Radiated Harmonics, 802.11n 40MHz, 19 dBi Panel, 5550 MHz

Note: All other emissions were measured at the noise floor of the spectrum analyzer.

Freq. (GHz)	Antenna Polarity (H/V)	Raw Amp. @ 3 m (Peak) / (Avg.)	P. Amp. (dB)	Ant. Cor. Factor (dB/m)	Cable Loss (dB)	EUT Field Strength Final Amp. (dBuV/m)	Limit Detector Peak / Avg. (Peak) / (Avg.)	Limit @ 3 m (dBuV/m)	Delta (dB)
11.34	V	44.62	34.78	39.50	7.56	56.89	Peak	74	-17.11
11.34	V	32.29	34.78	39.50	7.56	44.56	Avg.	54	-9.44
17.01	V	43.31	34.24	42.05	9.68	60.80	Peak	74	-13.20
17.01	V	30.98	34.24	42.05	9.68	48.47	Avg.	54	-5.53

Table 71. Radiated Harmonics, 802.11n 40MHz, 19 dBi Panel, 5670 MHz

Note: All other emissions were measured at the noise floor of the spectrum analyzer.

§ 15.209 Radiated Spurious Emissions Limits, 802.11a

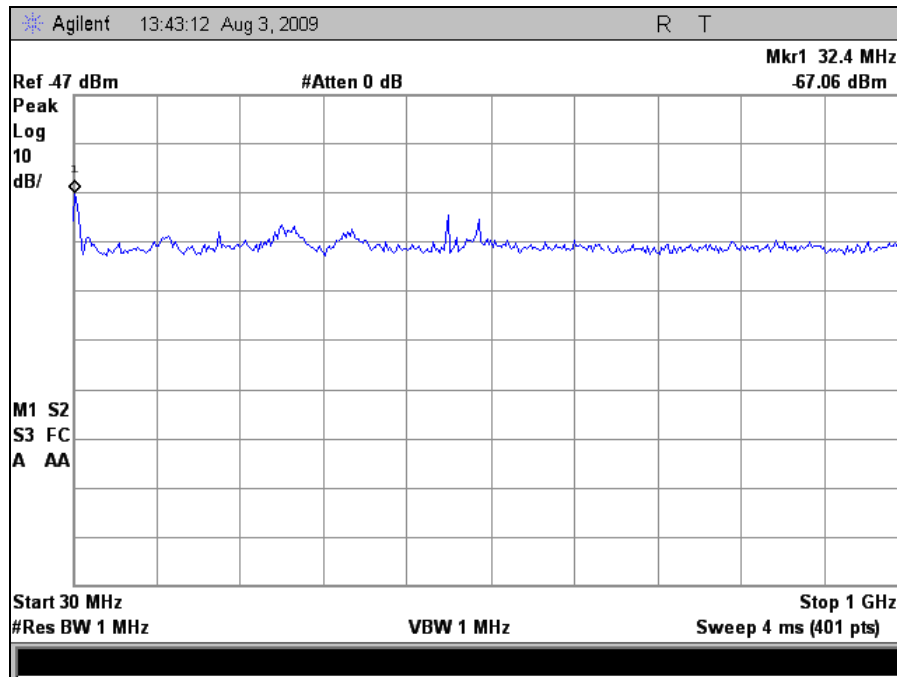

Plot 113. Radiated Spurious, 802.11a, 5260 MHz, 30 MHz – 1 GHz, 9 dBi Omni

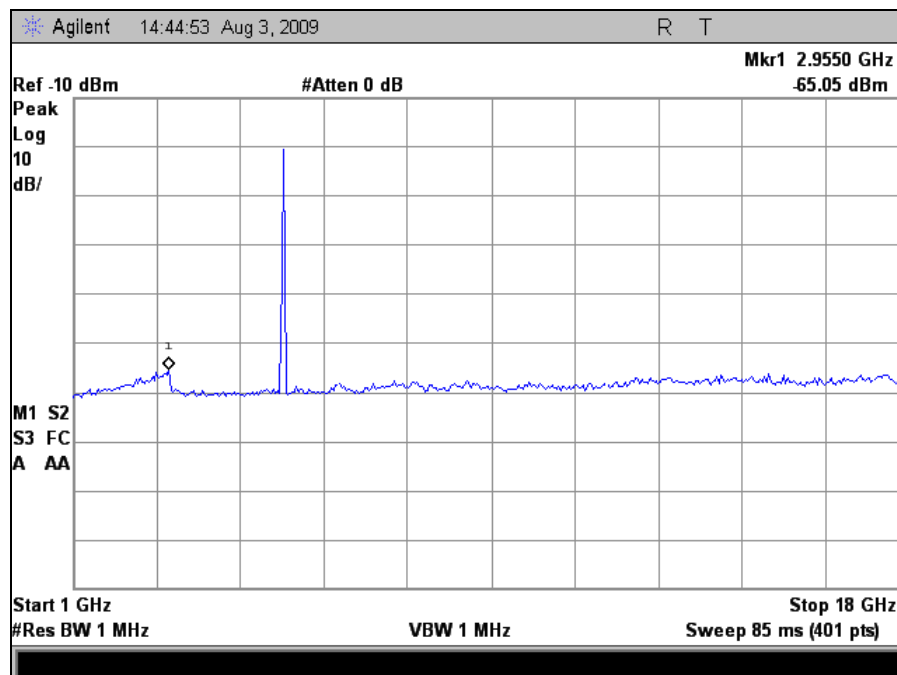

Plot 114. Radiated Spurious, 802.11a, 5260 MHz, 1 GHz – 18 GHz, 9 dBi Omni

Radiated Spurious Emissions Test Results, 802.11a (9dBi Omni Antenna)

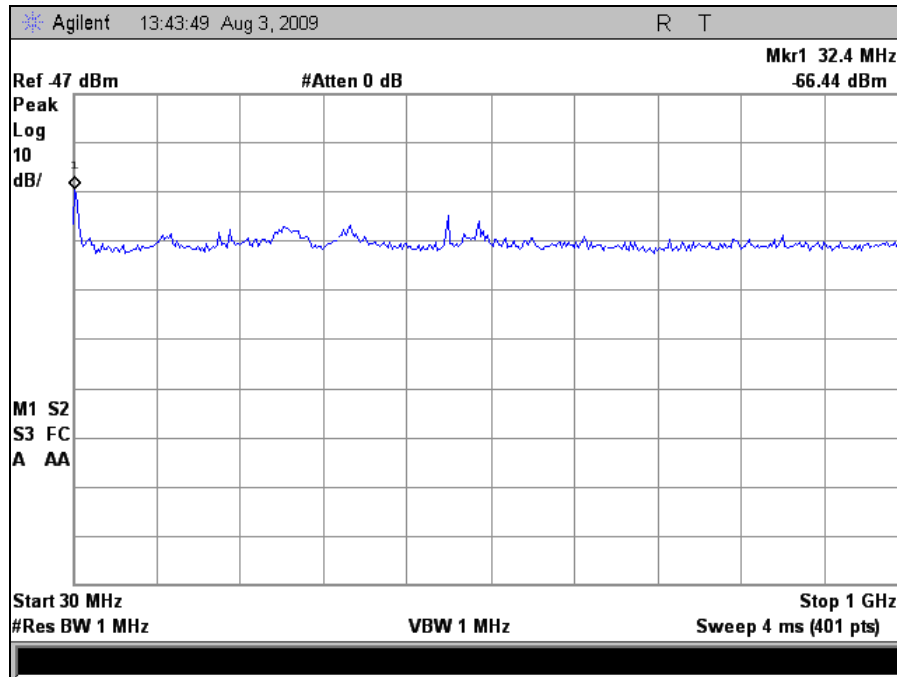

Plot 115. Radiated Spurious, 802.11a, 5320 MHz, 30 MHz – 1 GHz, 9 dBi Omni

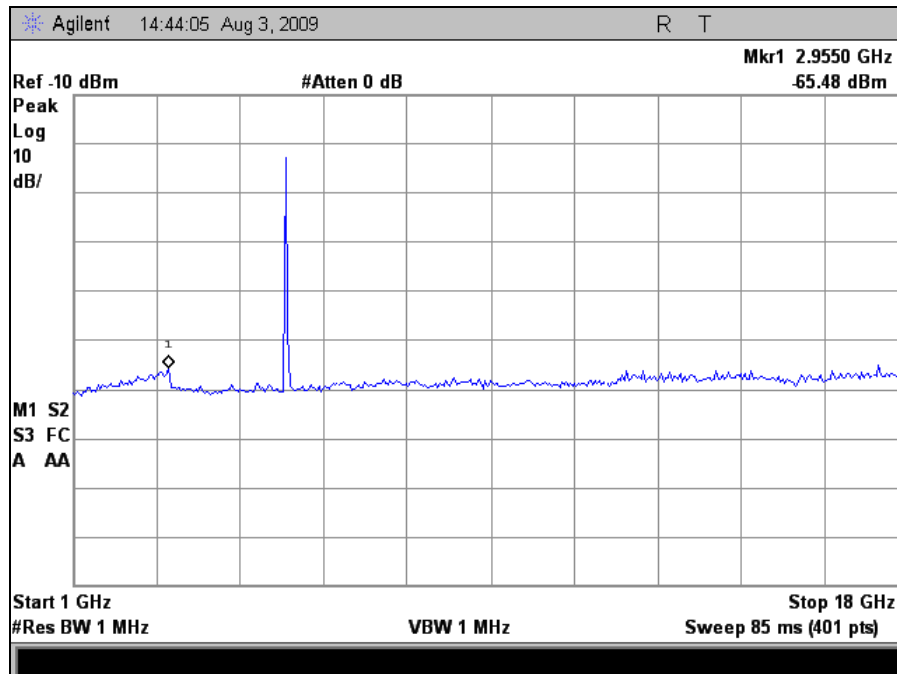

Plot 116. Radiated Spurious, 802.11a, 5320 MHz, 1 GHz – 18 GHz, 9 dBi Omni

Radiated Spurious Emissions Test Results, 802.11a (9dBi Omni Antenna)

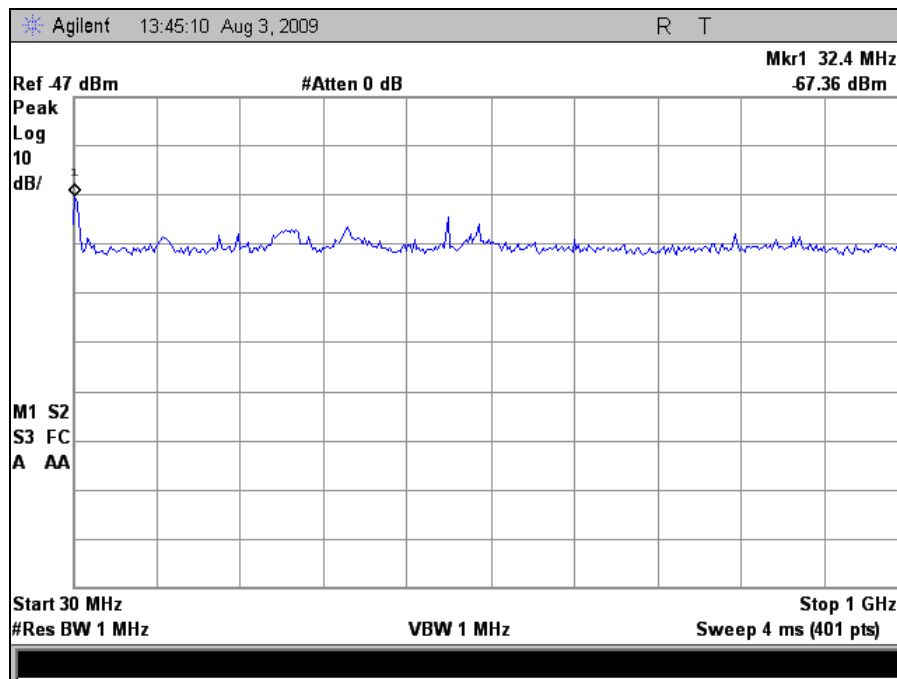

Plot 117. Radiated Spurious, 802.11a, 5500 MHz, 30 MHz – 1 GHz, 9 dBi Omni

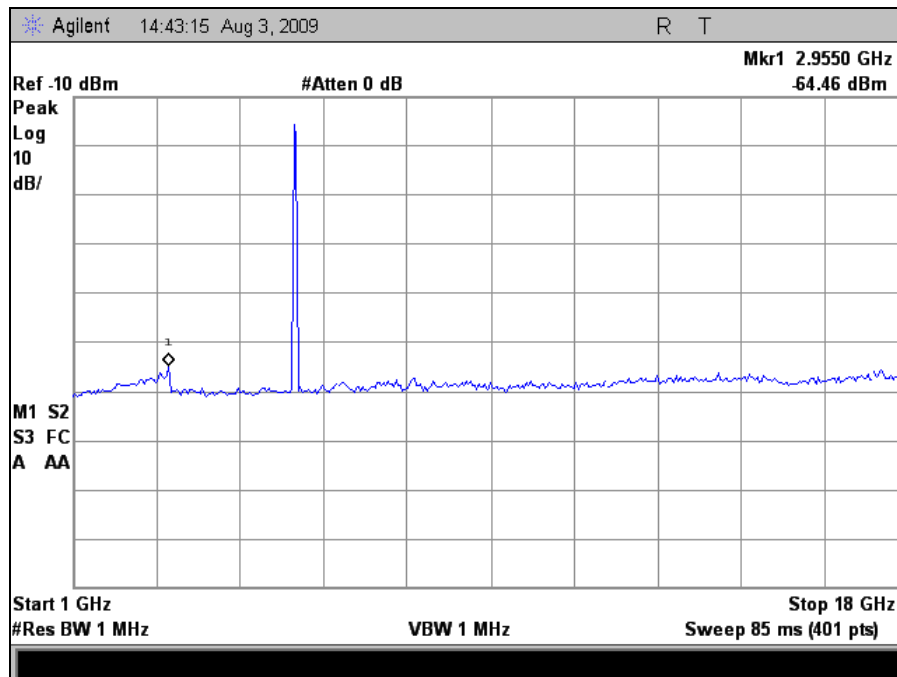

Plot 118. Radiated Spurious, 802.11a, 5500 MHz, 1 GHz – 18 GHz, 9 dBi Omni

Radiated Spurious Emissions Test Results, 802.11a (9dBi Omni Antenna)

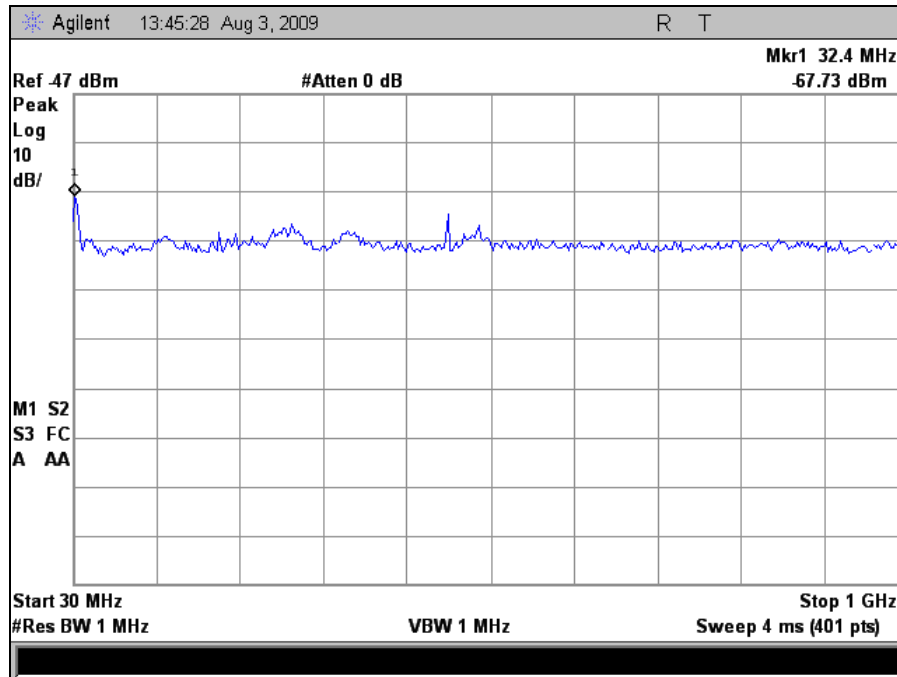

Plot 119. Radiated Spurious, 802.11a, 5580 MHz, 30 MHz – 1 GHz, 9 dBi Omni

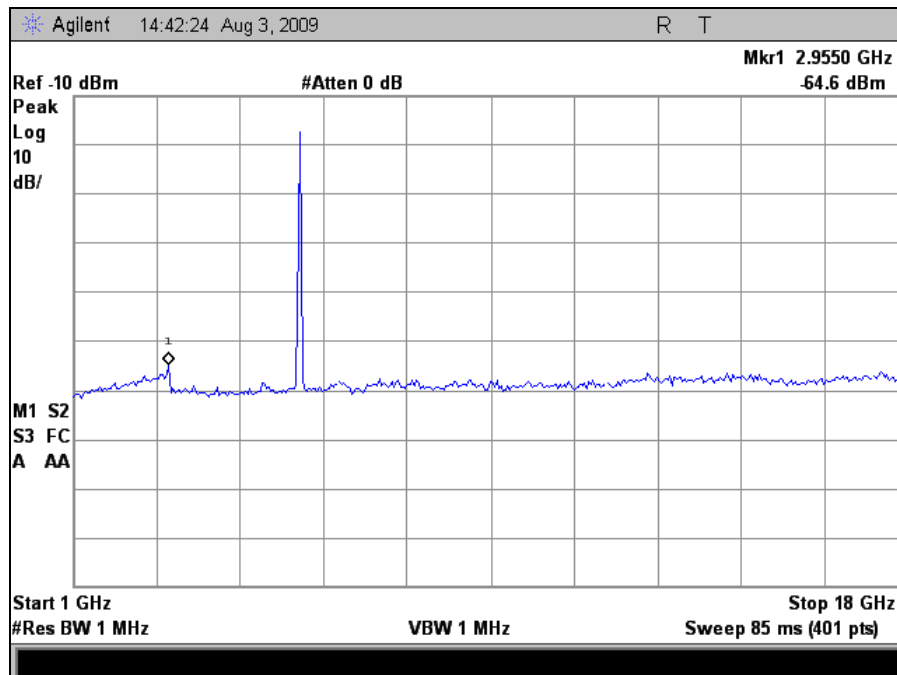

Plot 120. Radiated Spurious, 802.11a, 5580 MHz, 1 GHz – 18 GHz, 9 dBi Omni

Radiated Spurious Emissions Test Results, 802.11a (9dBi Omni Antenna)

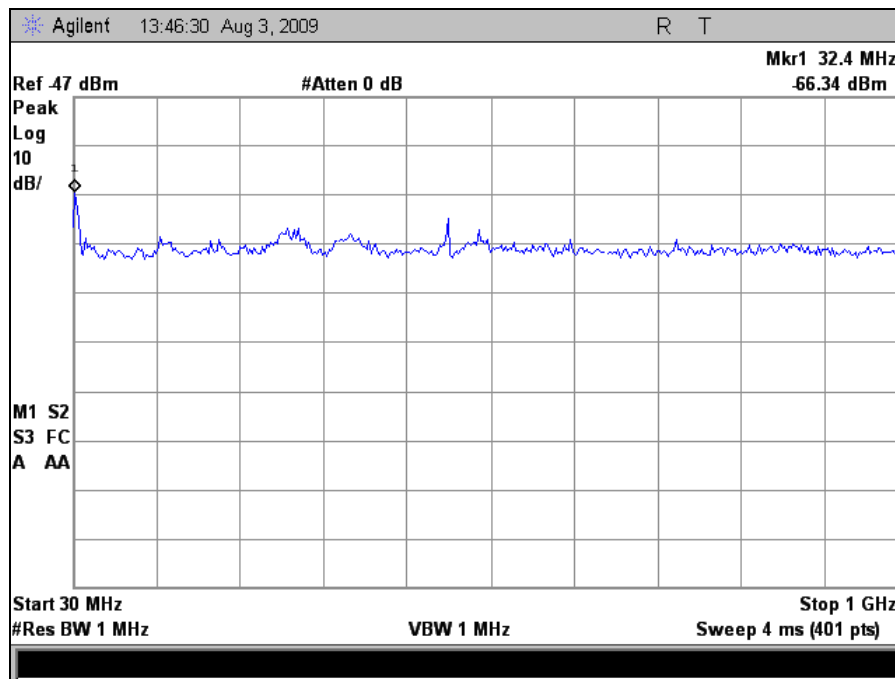

Plot 121. Radiated Spurious, 802.11a, 5700 MHz, 30 MHz – 1 GHz, 9 dBi Omni

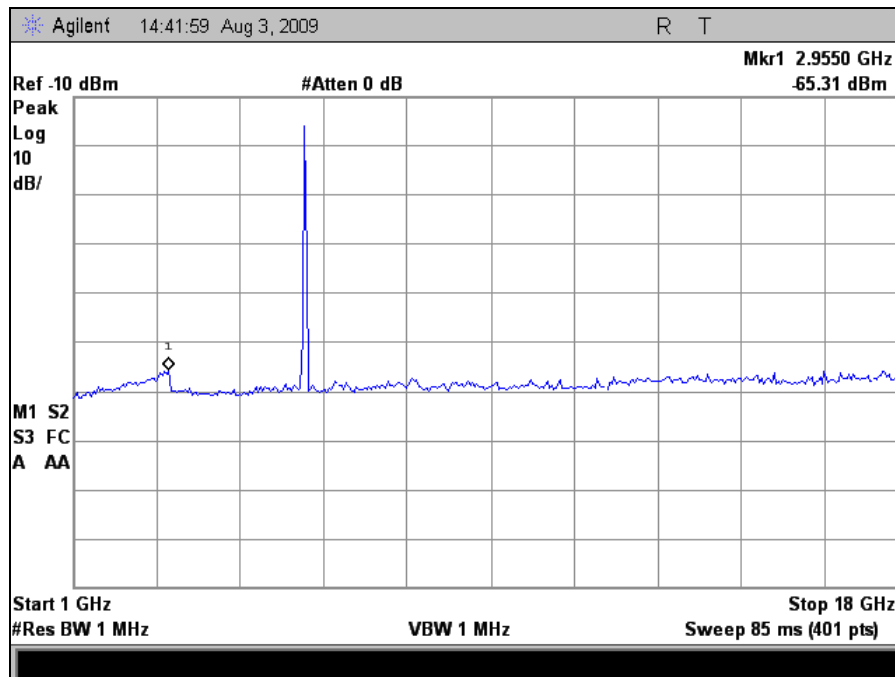

Plot 122. Radiated Spurious, 802.11a, 5700 MHz, 1 GHz – 18 GHz, 9 dBi Omni

Radiated Spurious Emissions Test Results, 802.11a (16dBi Sector Antenna)

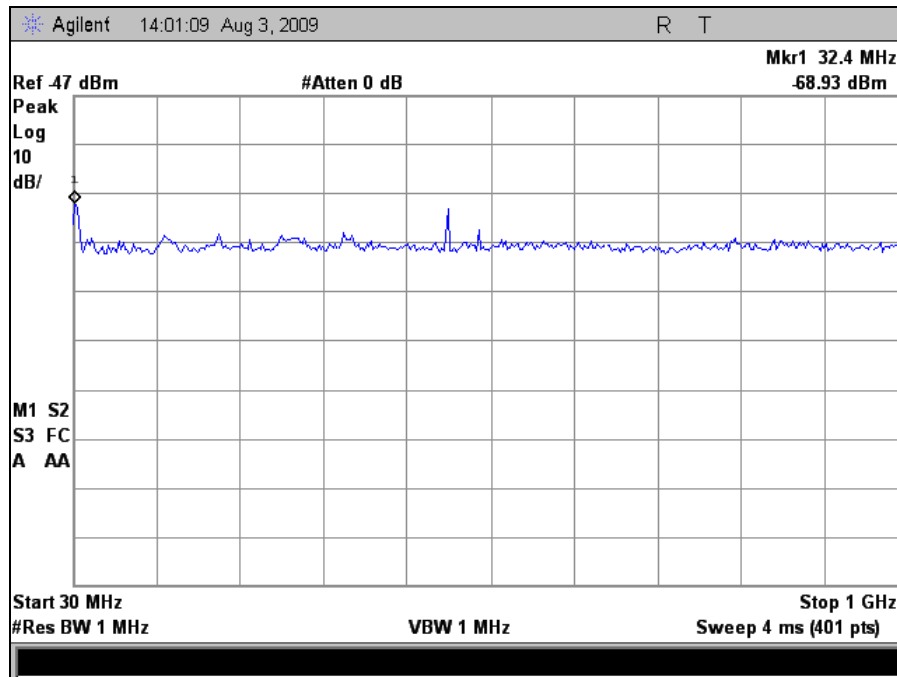

Plot 123. Radiated Spurious, 802.11a, 5260 MHz, 30 MHz – 1 GHz, 16 dBi Sector

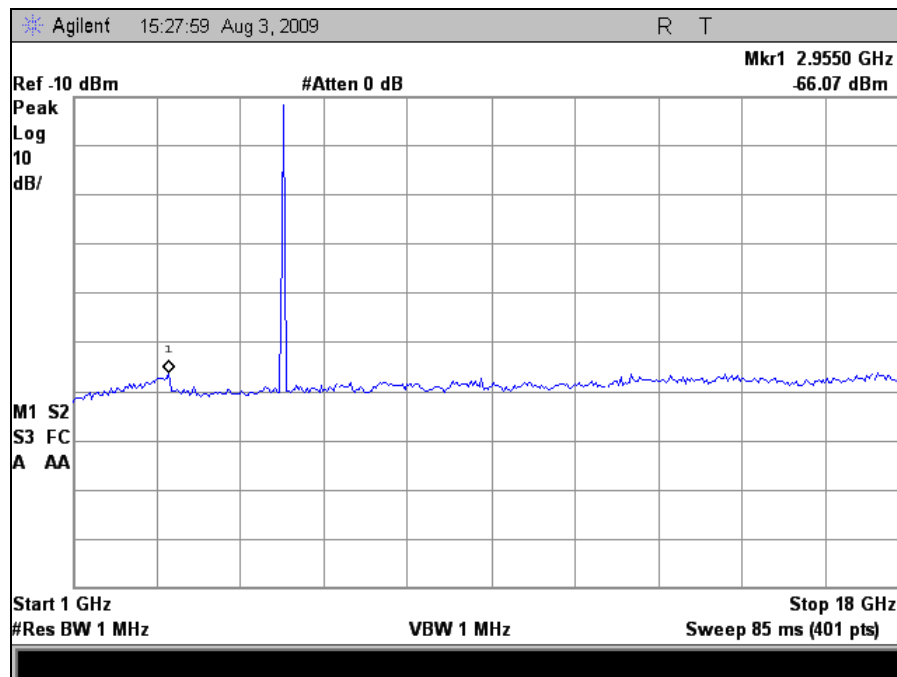

Plot 124. Radiated Spurious, 802.11a, 5260 MHz, 1 GHz – 18 GHz, 16 dBi Sector

Radiated Spurious Emissions Test Results, 802.11a (16dBi Sector Antenna)

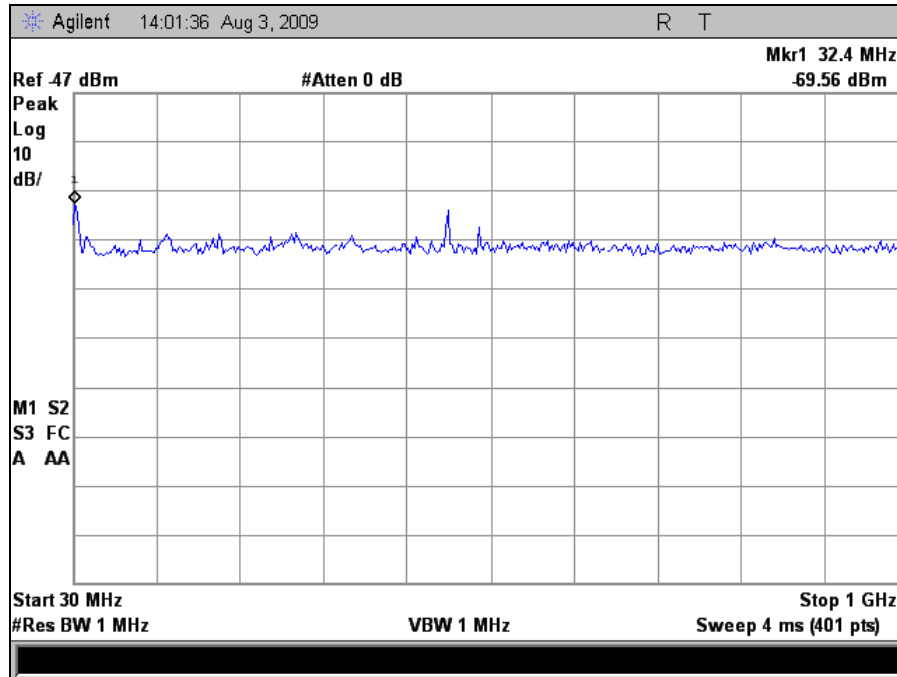

Plot 125. Radiated Spurious, 802.11a, 5320 MHz, 30 MHz – 1 GHz, 16 dBi Sector

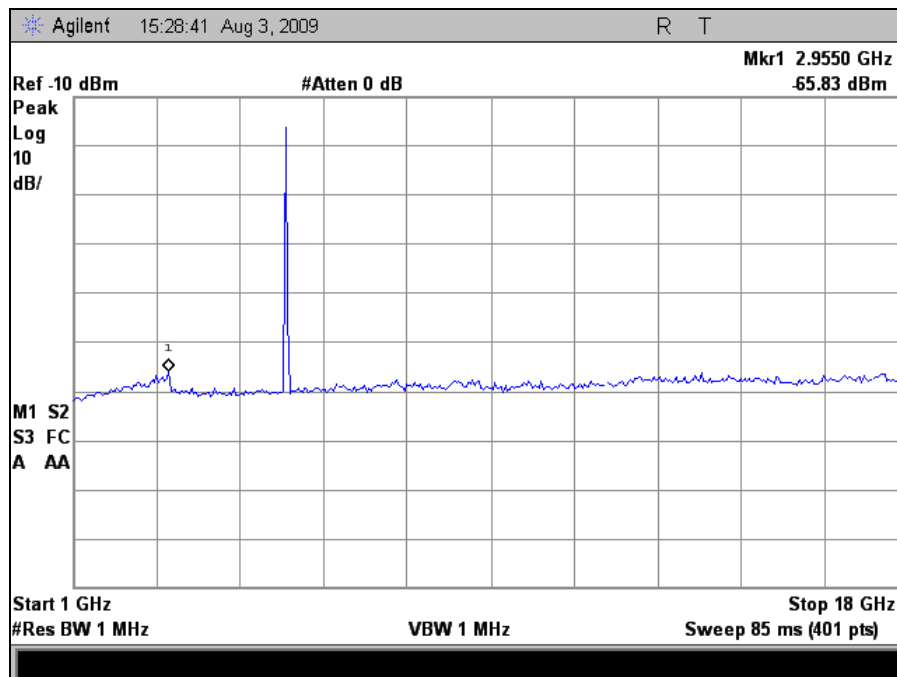

Plot 126. Radiated Spurious, 802.11a, 5320 MHz, 1 GHz – 18 GHz, 16 dBi Sector

Radiated Spurious Emissions Test Results, 802.11a (16dBi Sector Antenna)

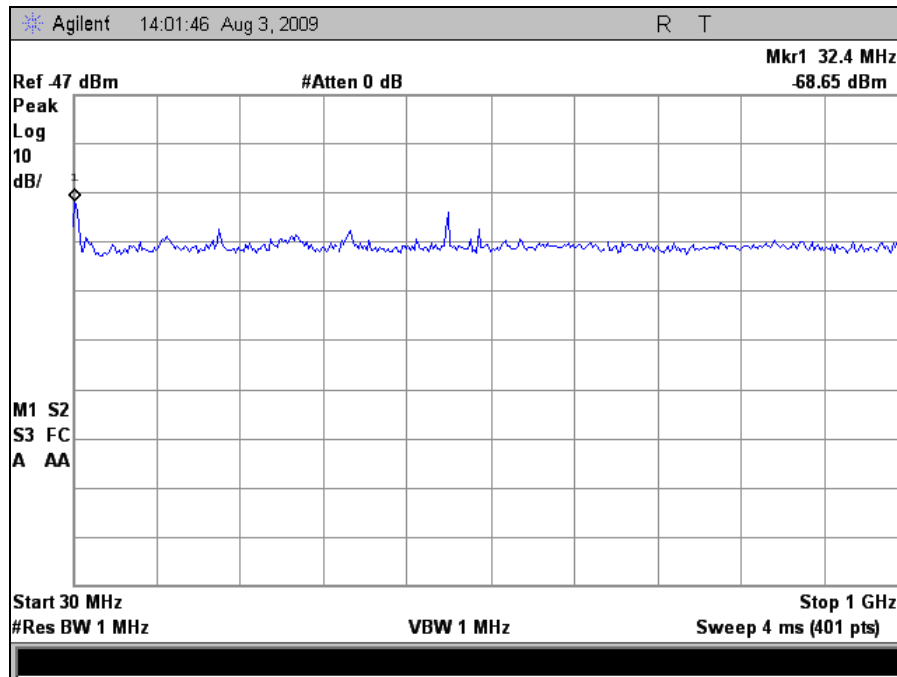

Plot 127. Radiated Spurious, 802.11a, 5500 MHz, 30 MHz – 1 GHz, 16 dBi Sector

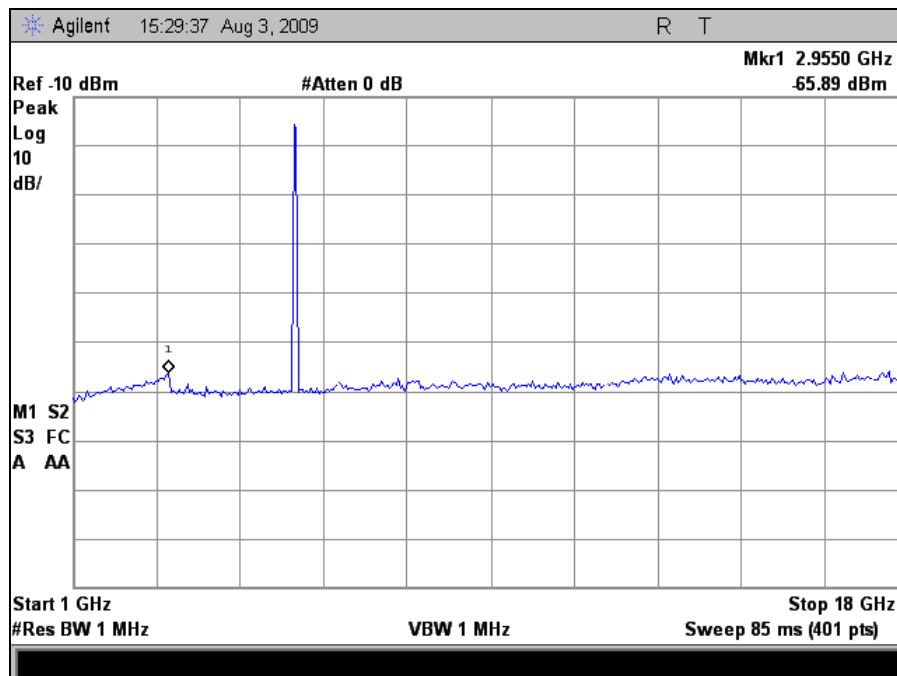

Plot 128. Radiated Spurious, 802.11a, 5500 MHz, 1 GHz – 18 GHz, 16 dBi Sector

Radiated Spurious Emissions Test Results, 802.11a (16dBi Sector Antenna)

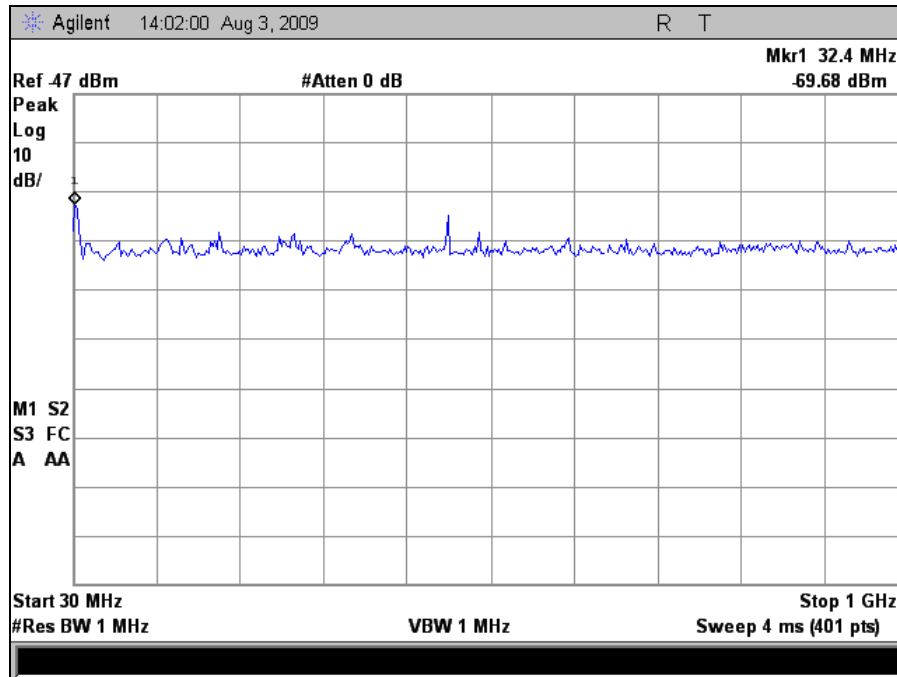

Plot 129. Radiated Spurious, 802.11a, 5580 MHz, 30 MHz – 1 GHz, 16 dBi Sector

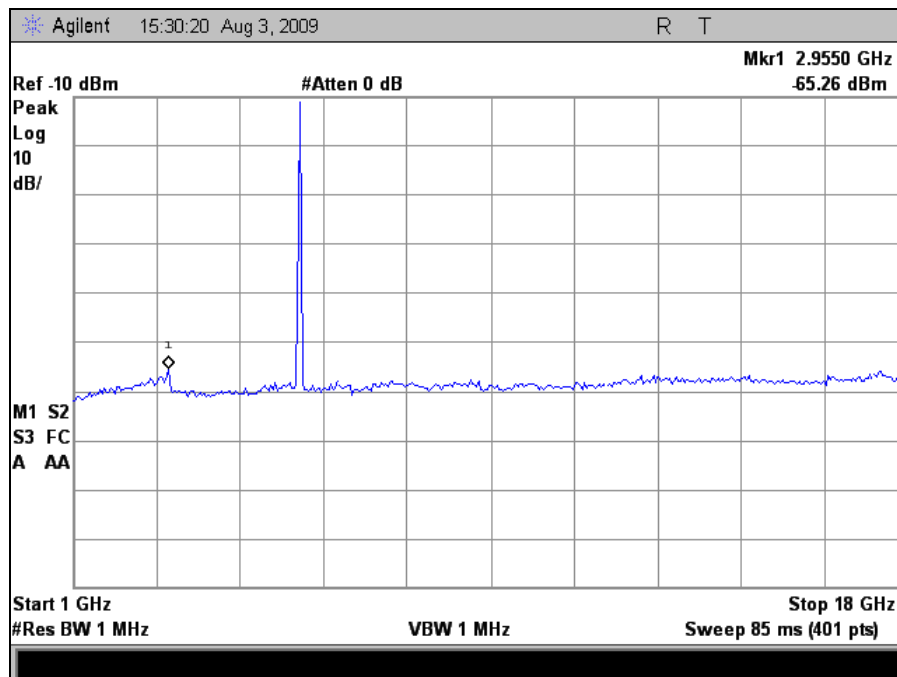

Plot 130. Radiated Spurious, 802.11a, 5580 MHz, 1 GHz – 18 GHz, 16 dBi Sector

Radiated Spurious Emissions Test Results, 802.11a (16dBi Sector Antenna)

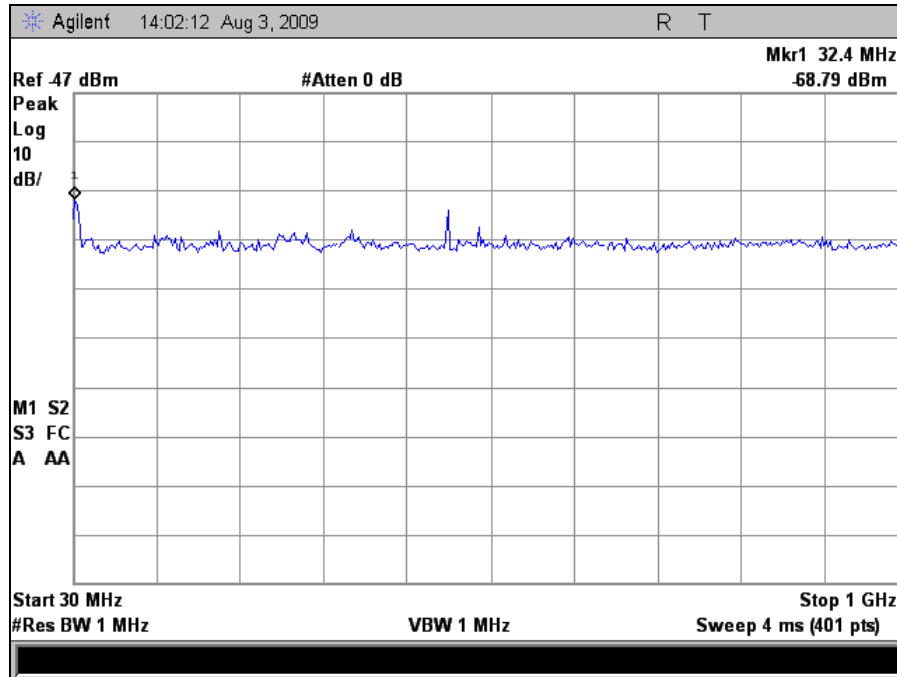

Plot 131. Radiated Spurious, 802.11a, 5700 MHz, 30 MHz – 1 GHz, 16 dBi Sector

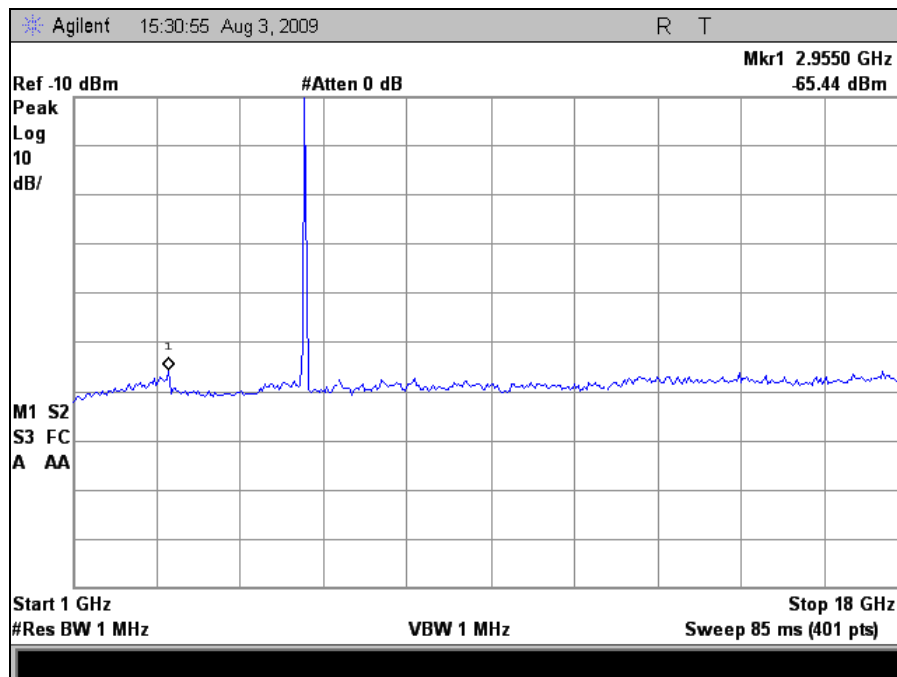

Plot 132. Radiated Spurious, 802.11a, 5700 MHz, 1 GHz – 18 GHz, 16 dBi Sector

Radiated Spurious Emissions Test Results, 802.11a (19dBi Panel Antenna)

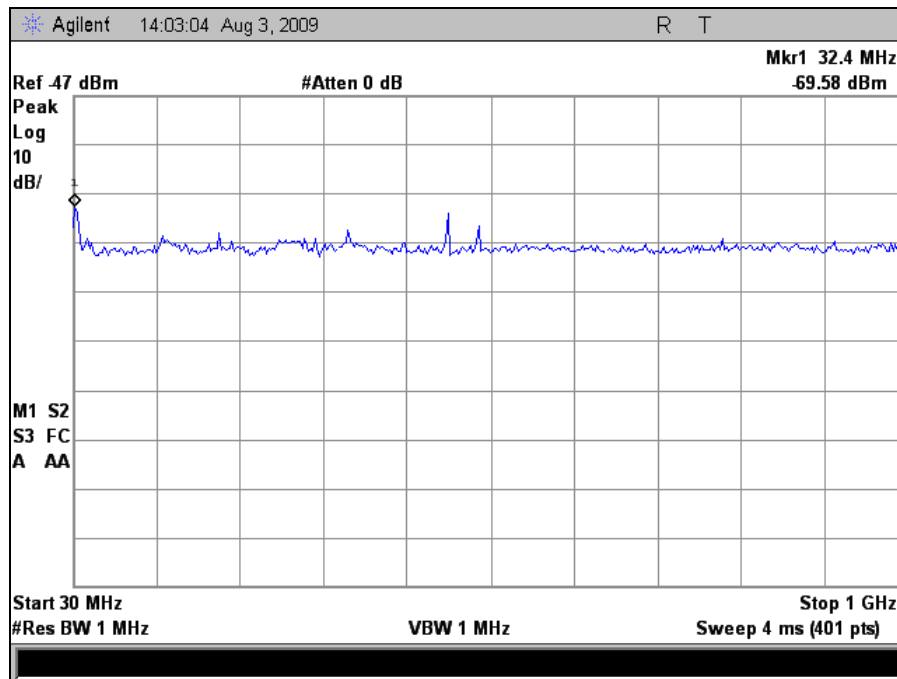

Plot 133. Radiated Spurious, 802.11a, 5260 MHz, 30 MHz – 1 GHz, 19 dBi Panel

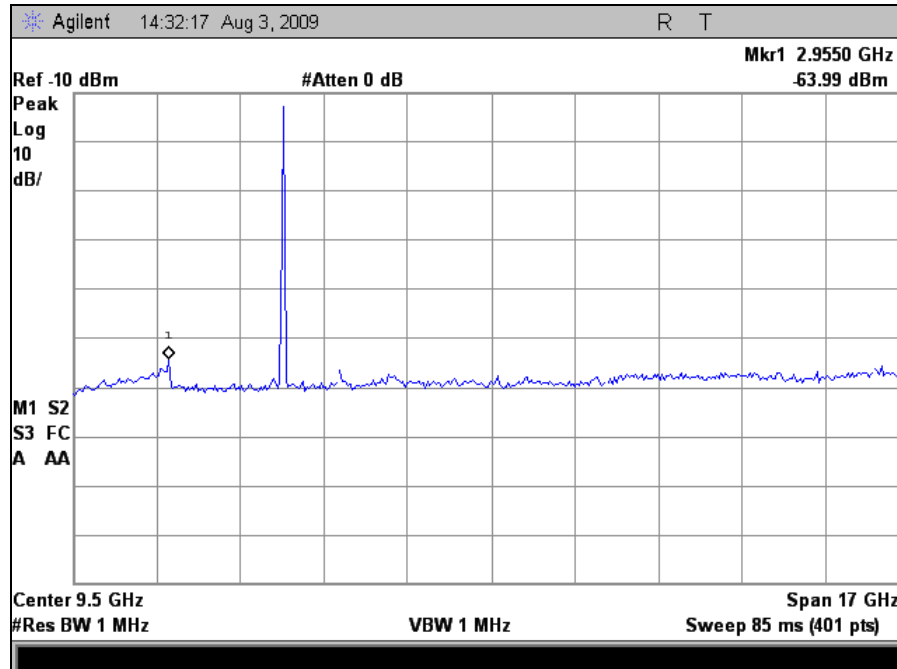

Plot 134. Radiated Spurious, 802.11a, 5260 MHz, 1 GHz – 18 GHz, 19 dBi Panel

Radiated Spurious Emissions Test Results, 802.11a (19dBi Panel Antenna)

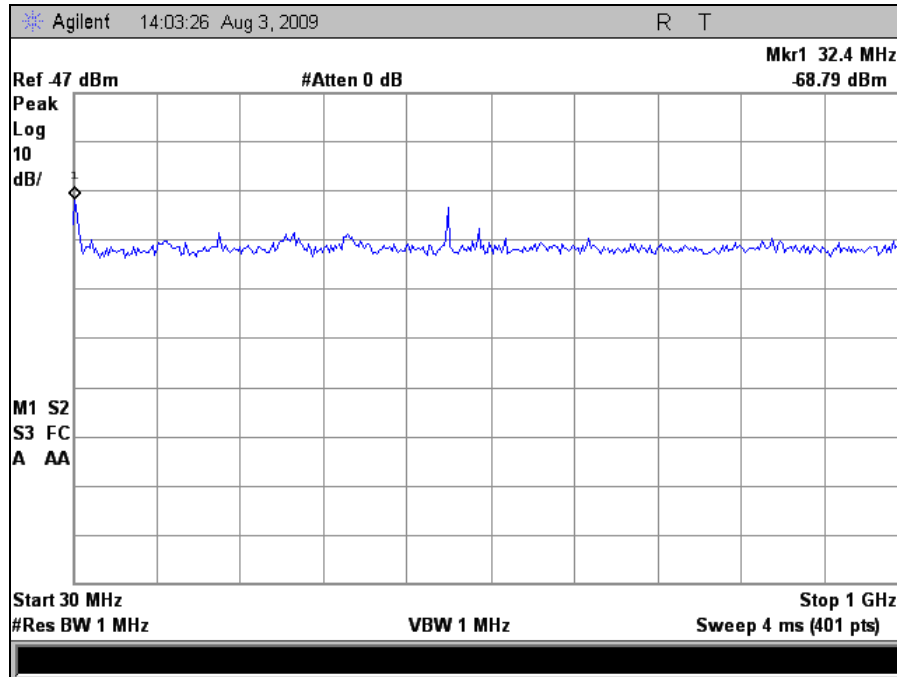

Plot 135. Radiated Spurious, 802.11a, 5320 MHz, 30 MHz – 1 GHz, 19 dBi Panel

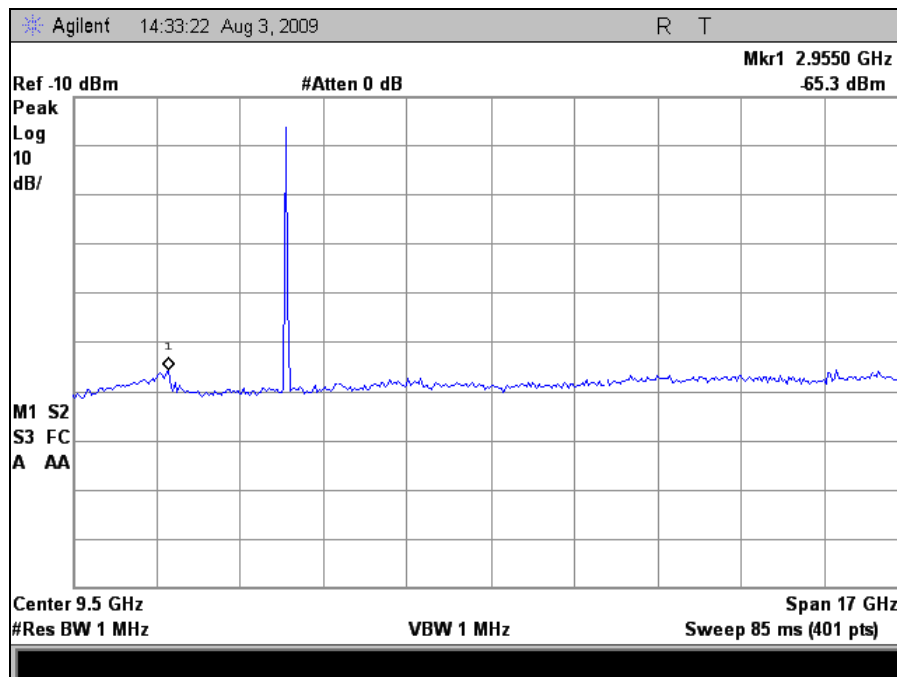

Plot 136. Radiated Spurious, 802.11a, 5320 MHz, 1 GHz – 18 GHz, 19 dBi Panel

Radiated Spurious Emissions Test Results, 802.11a (19dBi Panel Antenna)

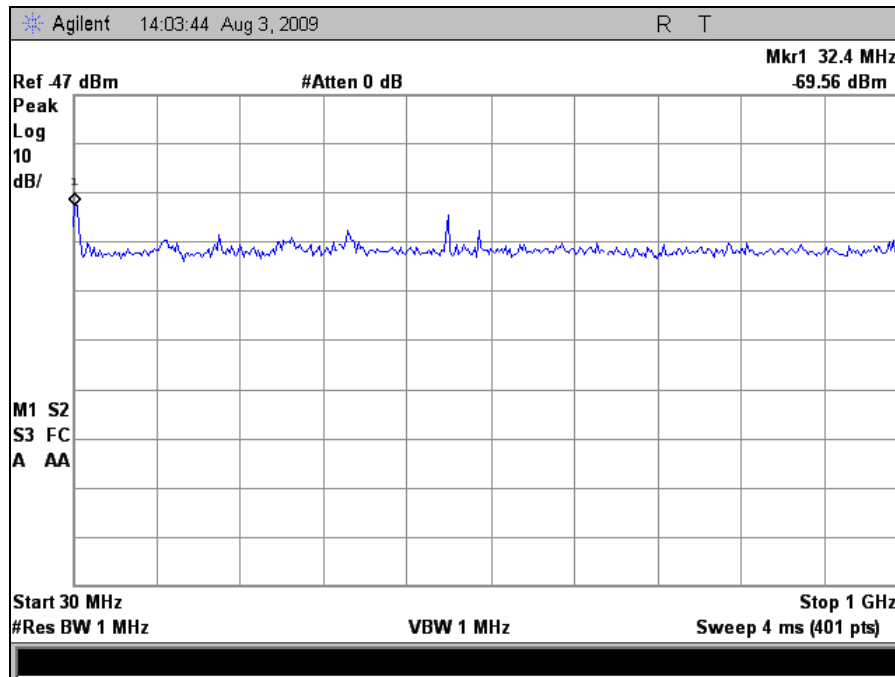

Plot 137. Radiated Spurious, 802.11a, 5500 MHz, 30 MHz – 1 GHz, 19 dBi Panel

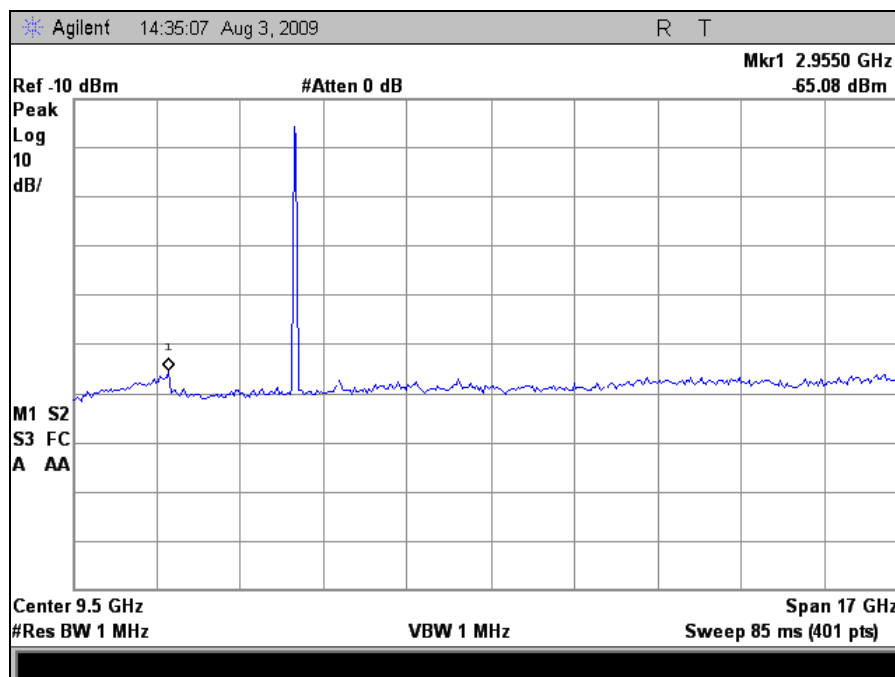

Plot 138. Radiated Spurious, 802.11a, 5500 MHz, 1 GHz – 18 GHz, 19 dBi Panel

Radiated Spurious Emissions Test Results, 802.11a (19dBi Panel Antenna)

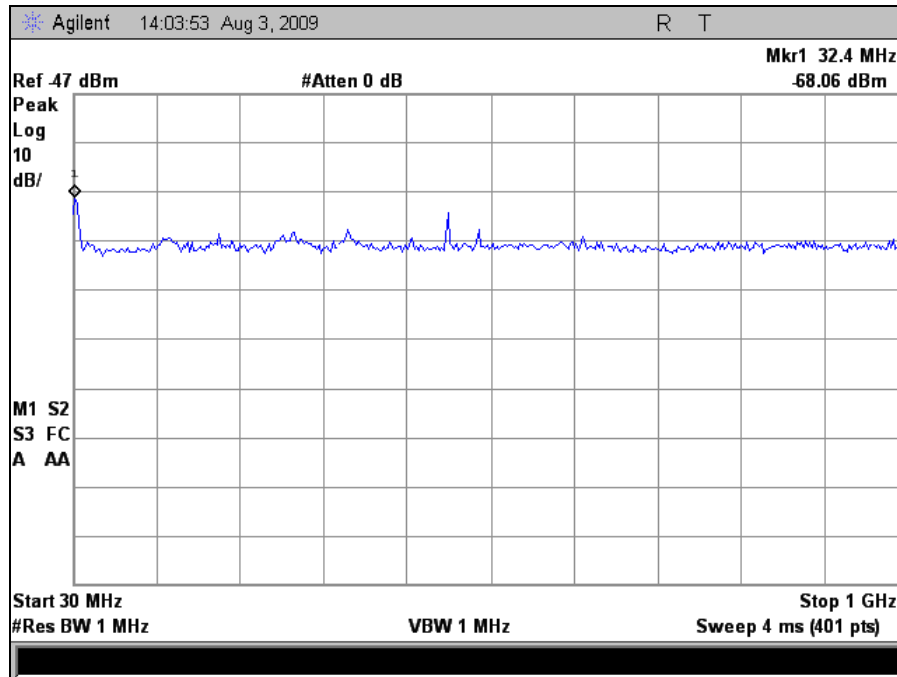

Plot 139. Radiated Spurious, 802.11a, 5580 MHz, 30 MHz – 1 GHz, 19 dBi Panel

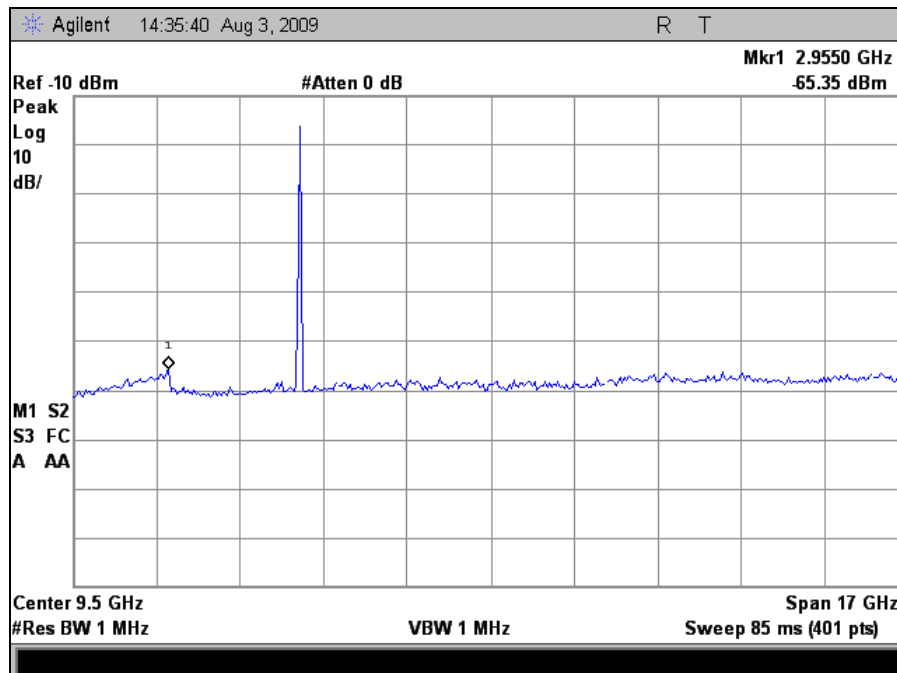

Plot 140. Radiated Spurious, 802.11a, 5580 MHz, 1 GHz – 18 GHz, 19 dBi Panel

Radiated Spurious Emissions Test Results, 802.11a (19dBi Panel Antenna)

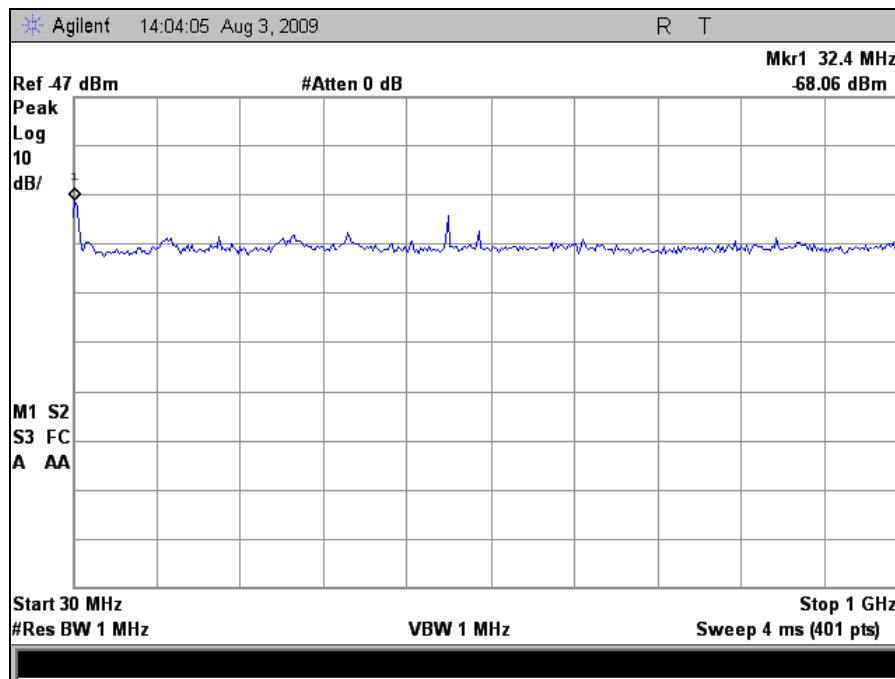

Plot 141. Radiated Spurious, 802.11a, 5700 MHz, 30 MHz – 1 GHz, 19 dBi Panel

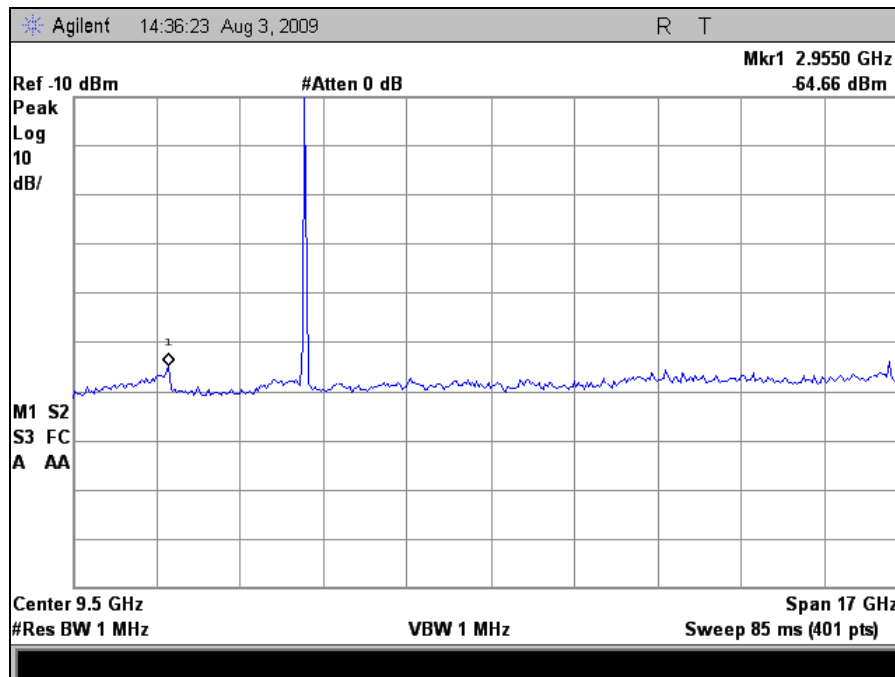

Plot 142. Radiated Spurious, 802.11a, 5700 MHz, 1 GHz – 18 GHz, 19 dBi Panel

Radiated Spurious Emissions Test Results, 802.11n 20MHz (9dBi Omni Antenna)

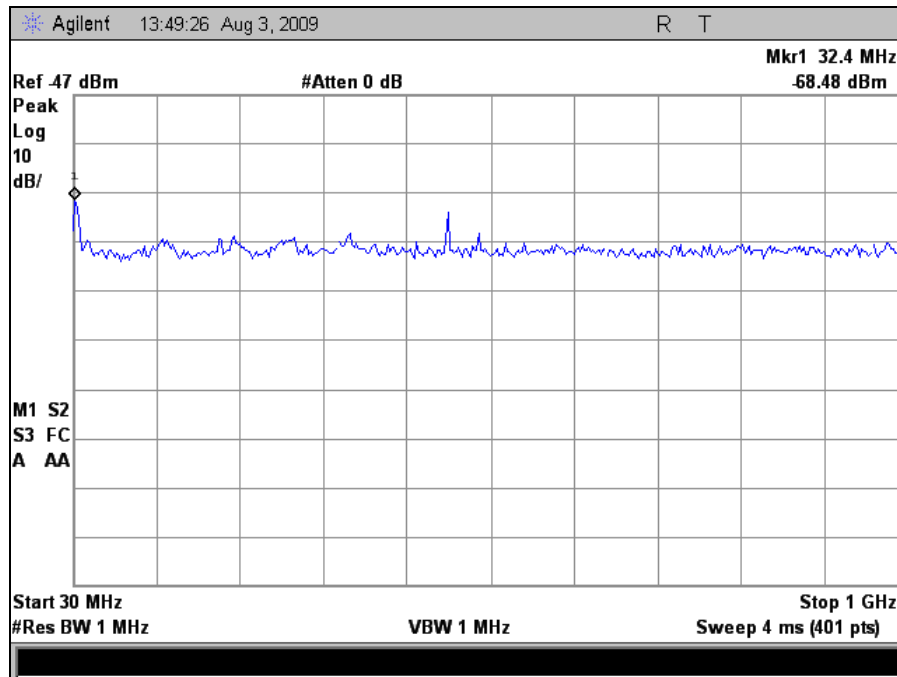

Plot 143. Radiated Spurious, 802.11n 20MHz, 5260 MHz, 30 MHz – 1 GHz, 9 dBi Omni

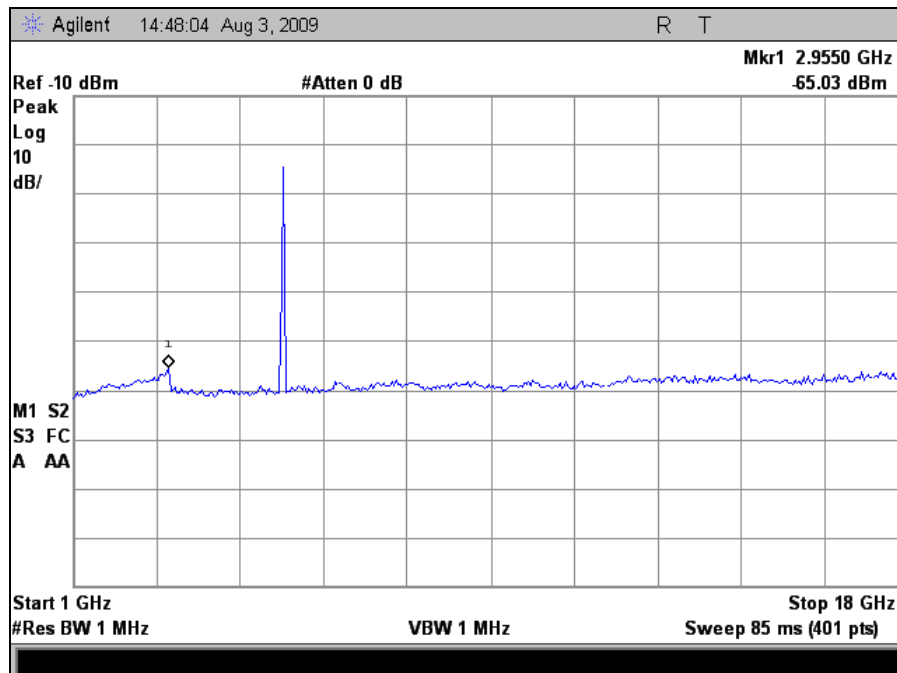

Plot 144. Radiated Spurious, 802.11n 20MHz, 5260 MHz, 1 GHz – 18 GHz, 9 dBi Omni

Radiated Spurious Emissions Test Results, 802.11n 20MHz (9dBi Omni Antenna)

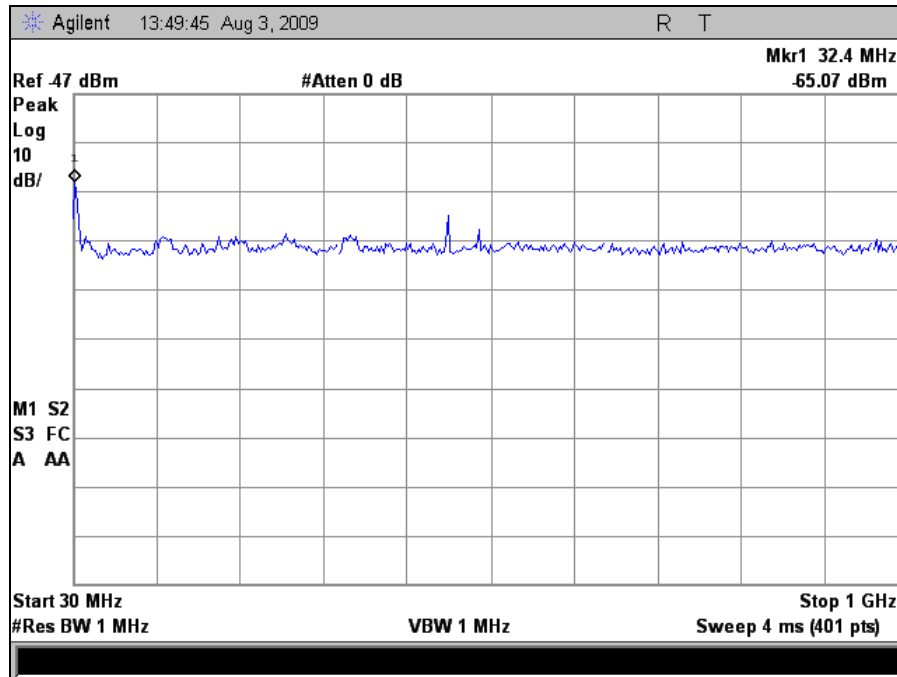

Plot 145. Radiated Spurious, 802.11n 20MHz, 5320 MHz, 30 MHz – 1 GHz, 9 dBi Omni

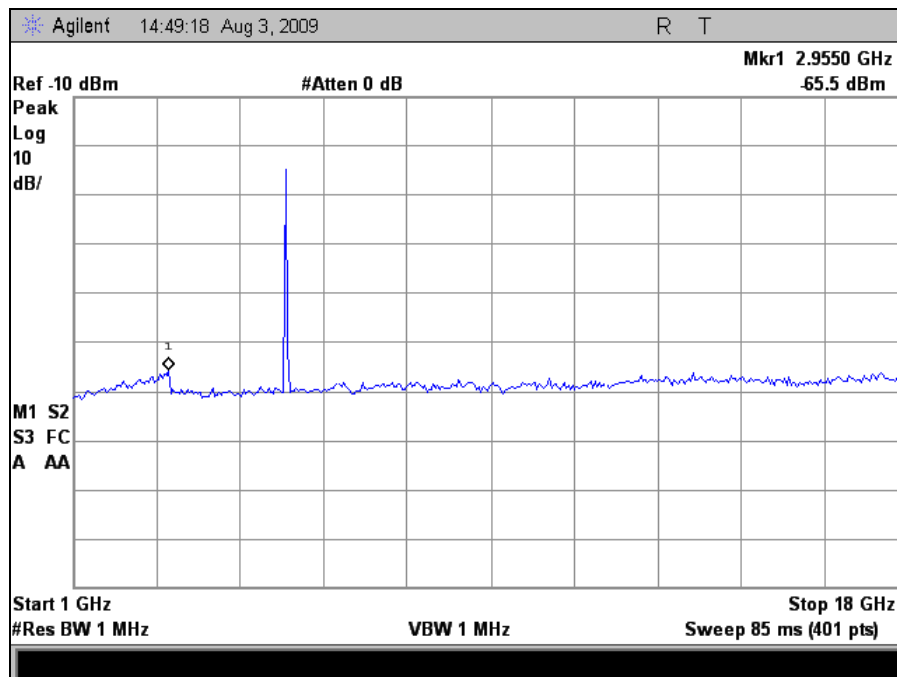

Plot 146. Radiated Spurious, 802.11n 20MHz, 5320 MHz, 1 GHz – 18 GHz, 9 dBi Omni

Radiated Spurious Emissions Test Results, 802.11n 20MHz (9dBi Omni Antenna)

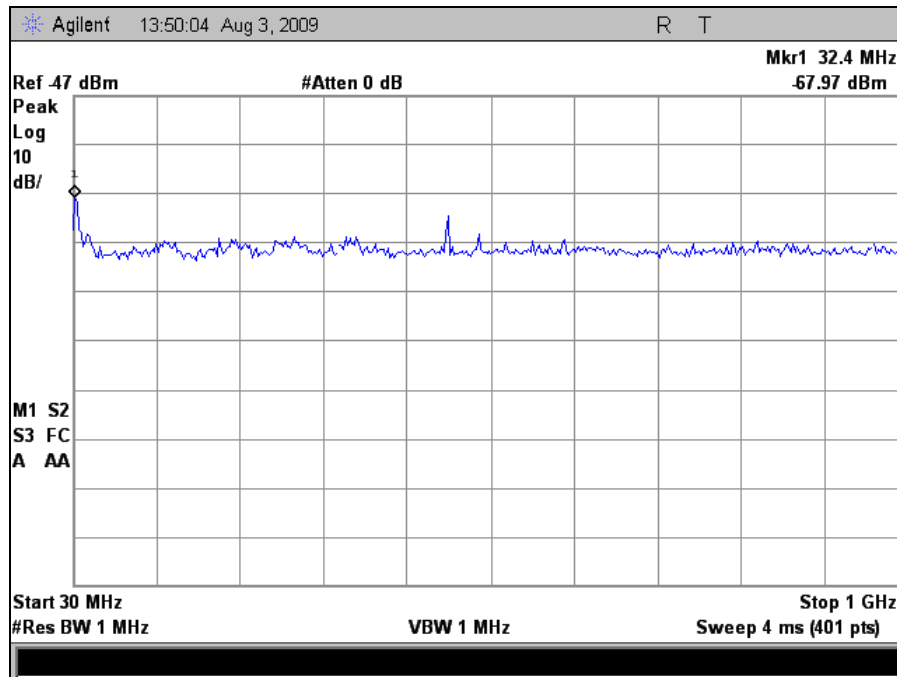

Plot 147. Radiated Spurious, 802.11n 20MHz, 5500 MHz, 30 MHz – 1 GHz, 9 dBi Omni

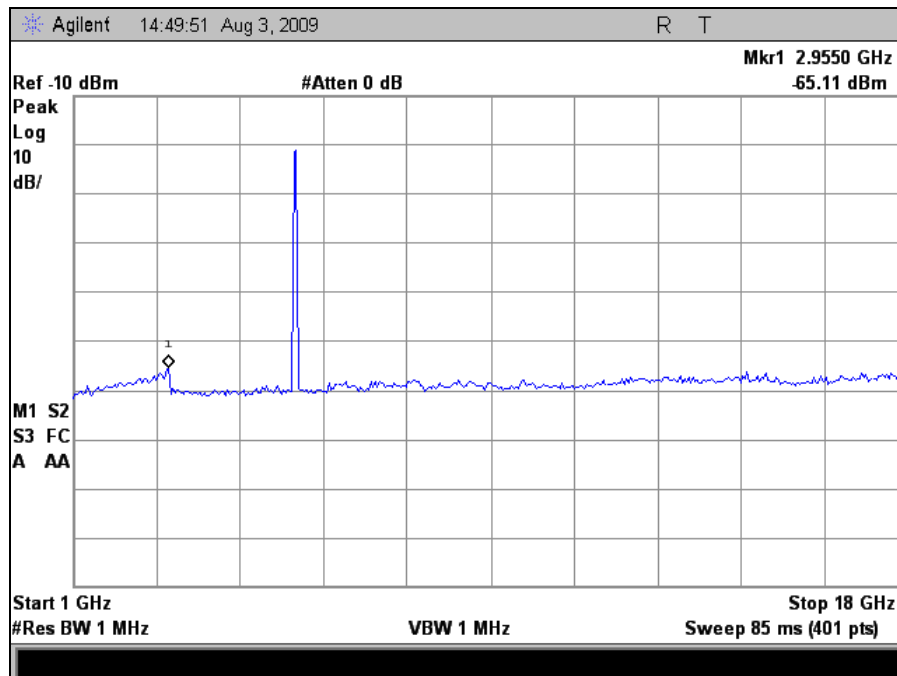

Plot 148. Radiated Spurious, 802.11n 20MHz, 5500 MHz, 1 GHz – 18 GHz, 9 dBi Omni

Radiated Spurious Emissions Test Results, 802.11n 20MHz (9dBi Omni Antenna)

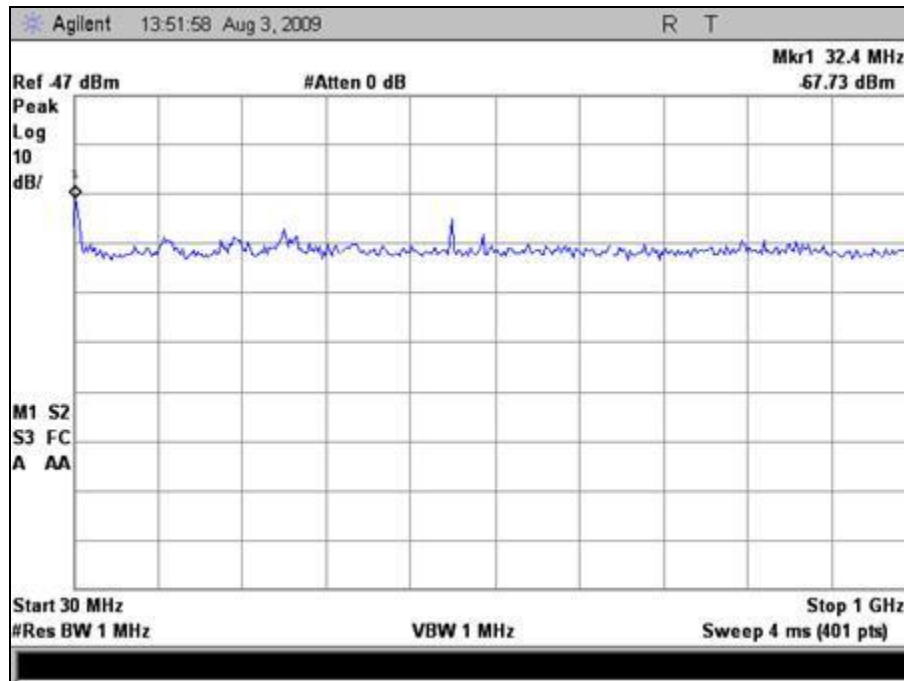

Plot 149. Radiated Spurious, 802.11n 20MHz, 5580 MHz, 30 MHz – 1 GHz, 9 dBi Omni

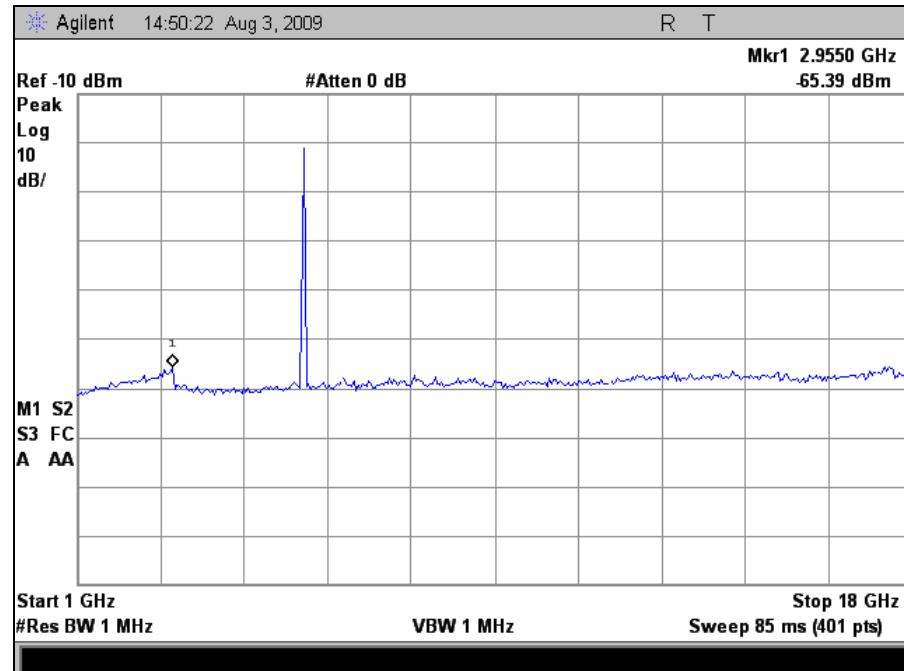

Plot 150. Radiated Spurious, 802.11n 20MHz, 5580 MHz, 1 GHz – 18 GHz, 9 dBi Omni

Radiated Spurious Emissions Test Results, 802.11n 20MHz (9dBi Omni Antenna)

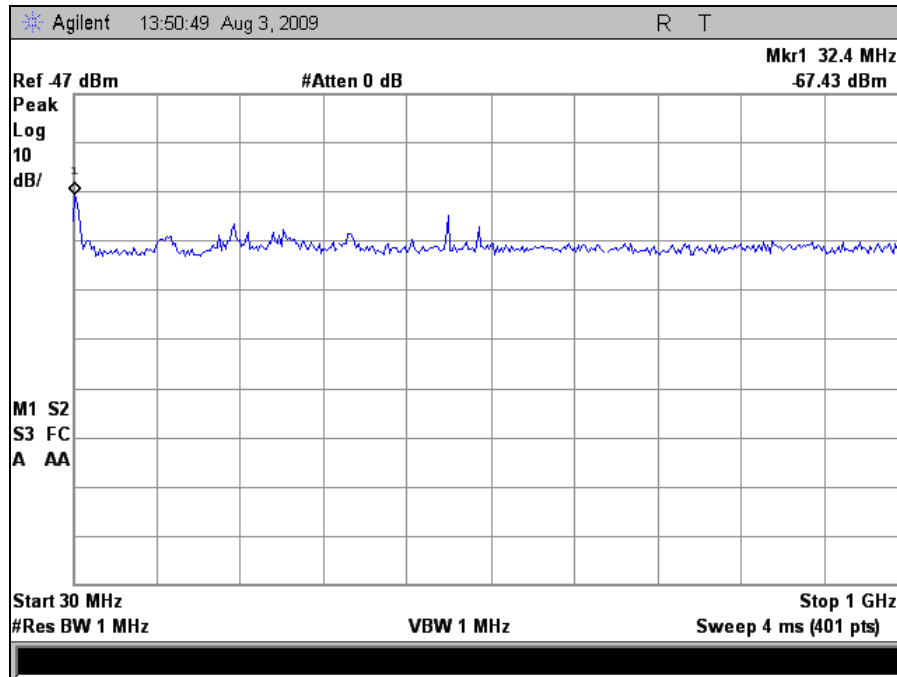

Plot 151. Radiated Spurious, 802.11n 20MHz, 5700 MHz, 30 MHz – 1 GHz, 9 dBi Omni

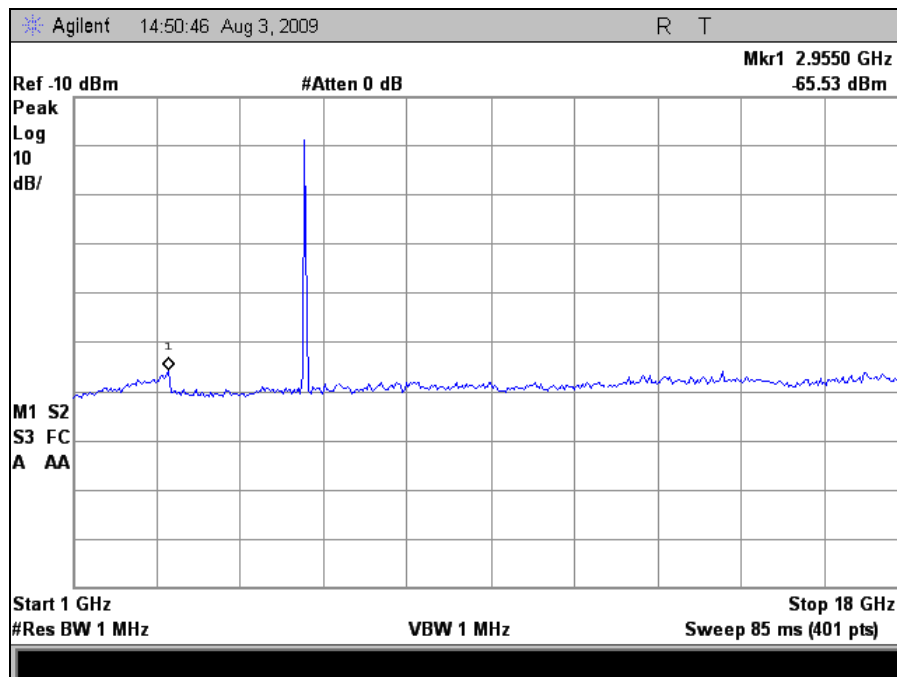

Plot 152. Radiated Spurious, 802.11n 20MHz, 5700 MHz, 1 GHz – 18 GHz, 9 dBi Omni

Radiated Spurious Emissions Test Results, 802.11n 20MHz (16dBi Sector Antenna)

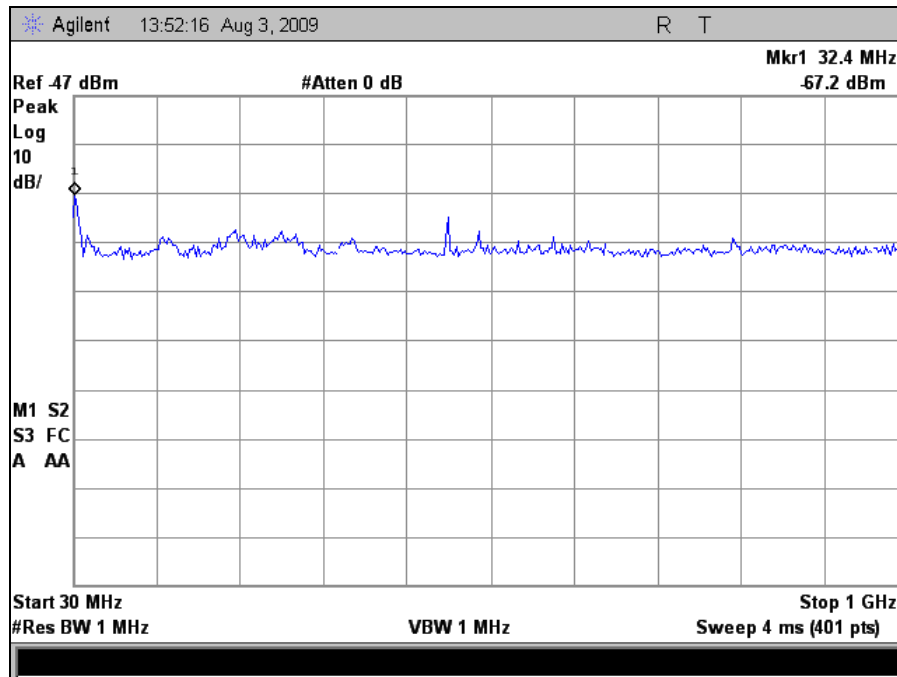

Plot 153. Radiated Spurious, 802.11n 20MHz, 5260 MHz, 30 MHz – 1 GHz, 16 dBi Sector

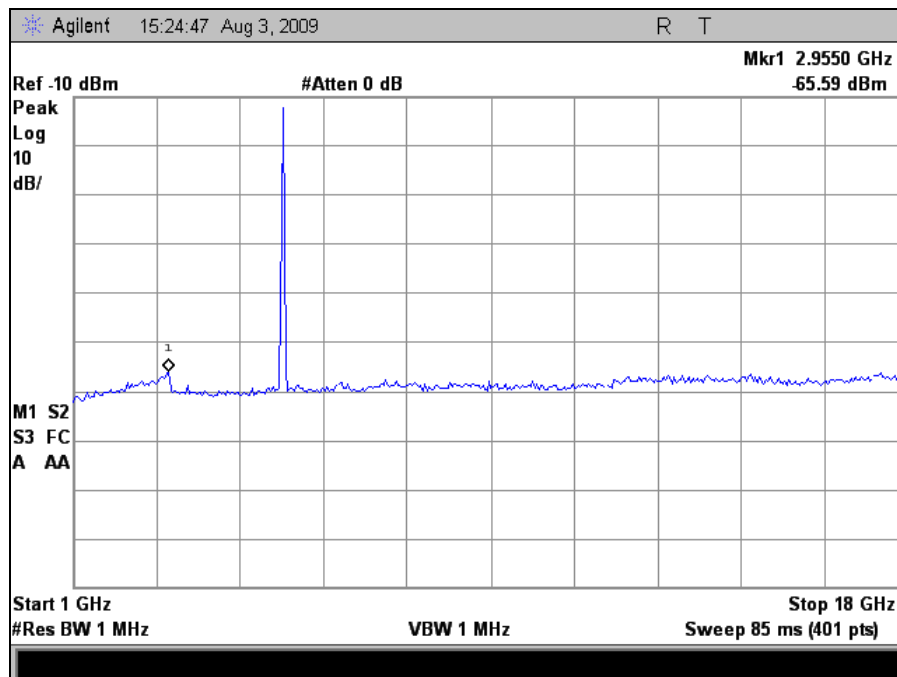

Plot 154. Radiated Spurious, 802.11n 20MHz, 5260 MHz, 1 GHz – 18 GHz, 16 dBi Sector

Radiated Spurious Emissions Test Results, 802.11n 20MHz (16dBi Sector Antenna)

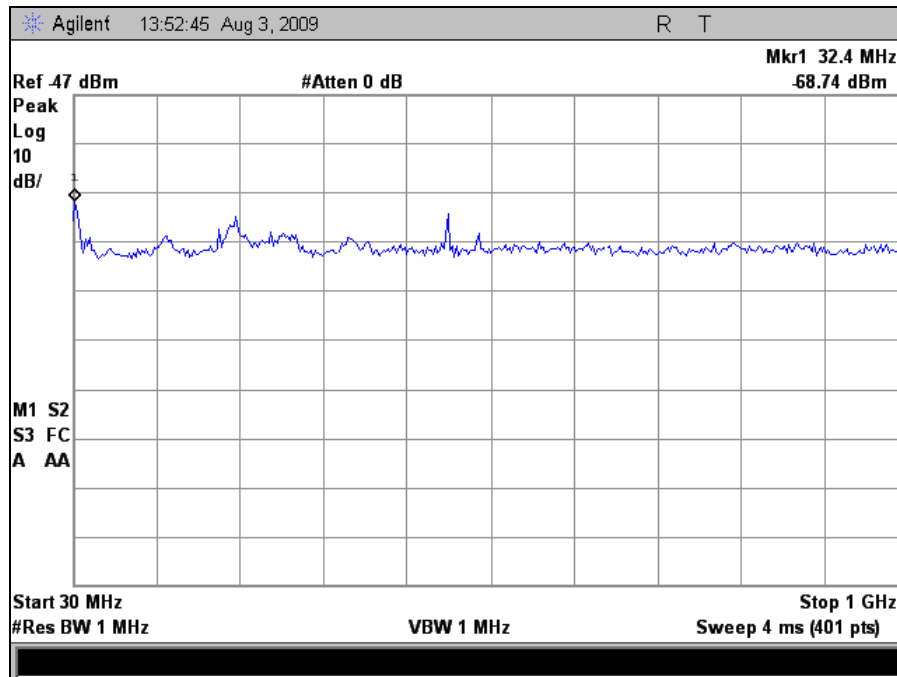

Plot 155. Radiated Spurious, 802.11n 20MHz, 5320 MHz, 30 MHz – 1 GHz, 16 dBi Sector

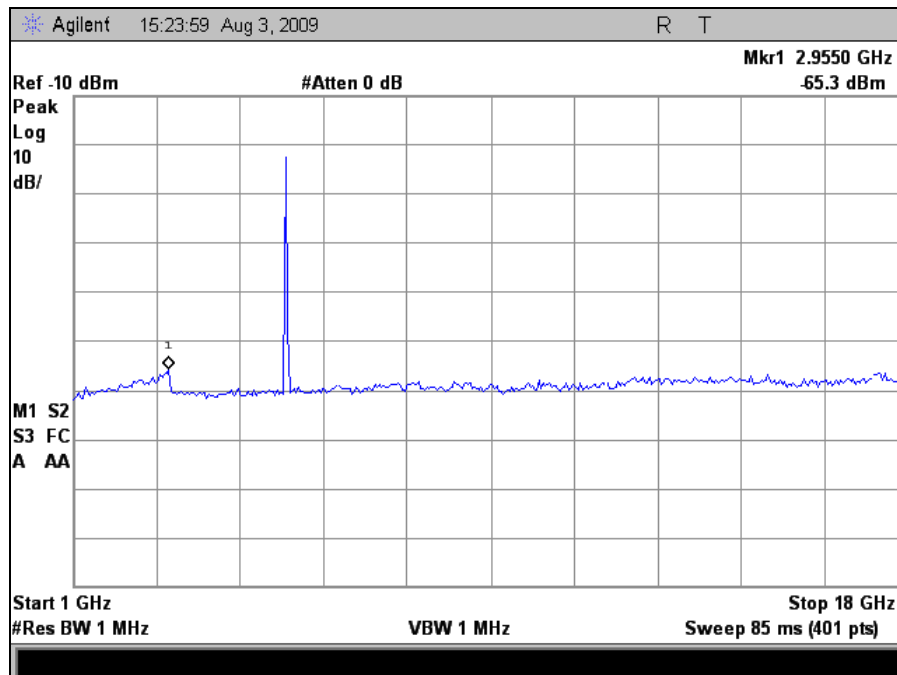

Plot 156. Radiated Spurious, 802.11n 20MHz, 5320 MHz, 1 GHz – 18 GHz, 16 dBi Sector

Radiated Spurious Emissions Test Results, 802.11n 20MHz (16dBi Sector Antenna)

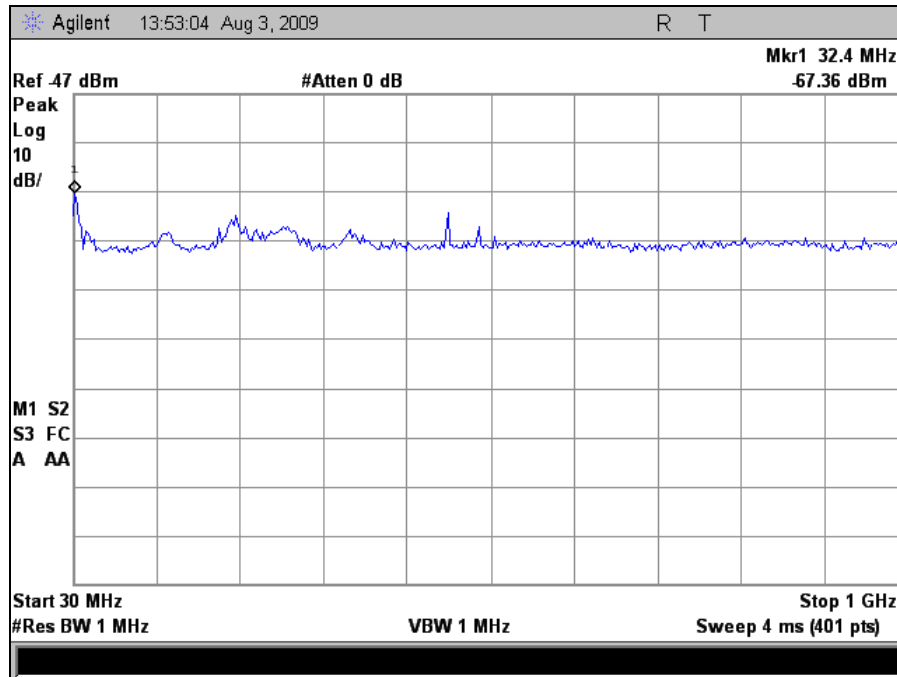

Plot 157. Radiated Spurious, 802.11n 20MHz, 5500 MHz, 30 MHz – 1 GHz, 16 dBi Sector

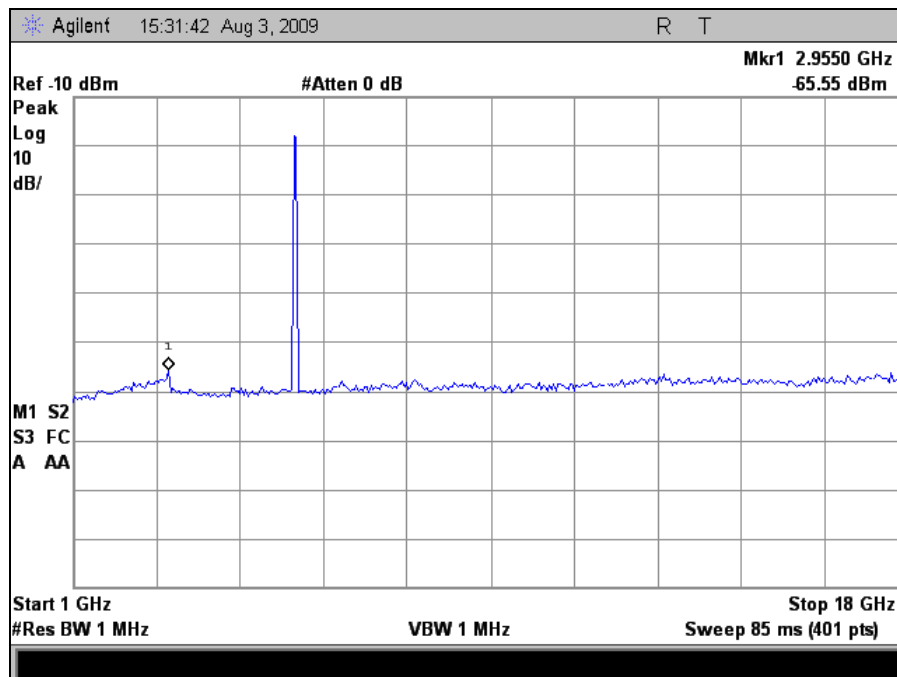

Plot 158. Radiated Spurious, 802.11n 20MHz, 5500 MHz, 1 GHz – 18 GHz, 16 dBi Sector

Radiated Spurious Emissions Test Results, 802.11n 20MHz (16dBi Sector Antenna)

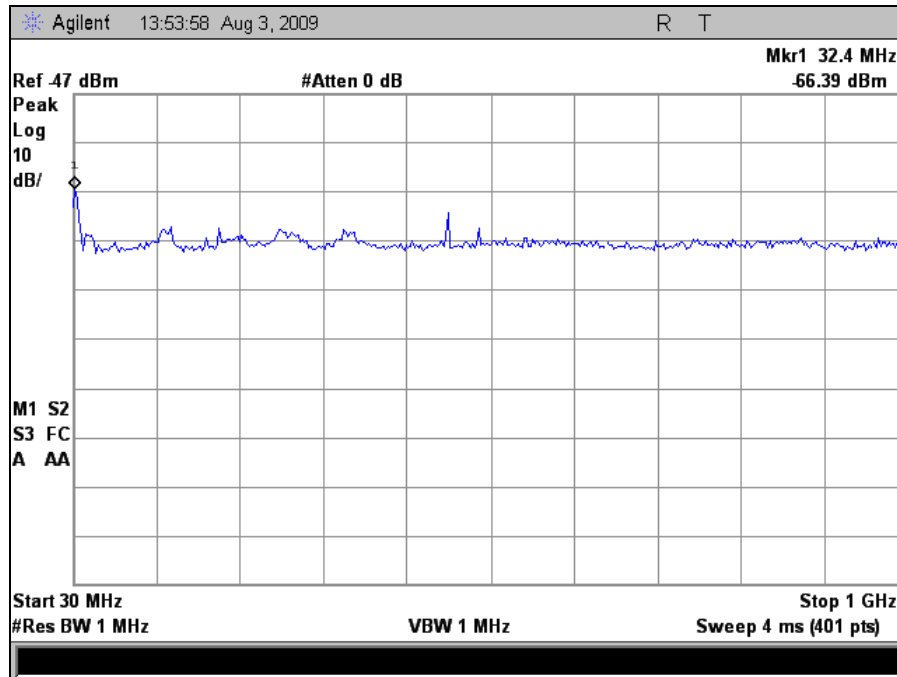

Plot 159. Radiated Spurious, 802.11n 20MHz, 5580 MHz, 30 MHz – 1 GHz, 16 dBi Sector

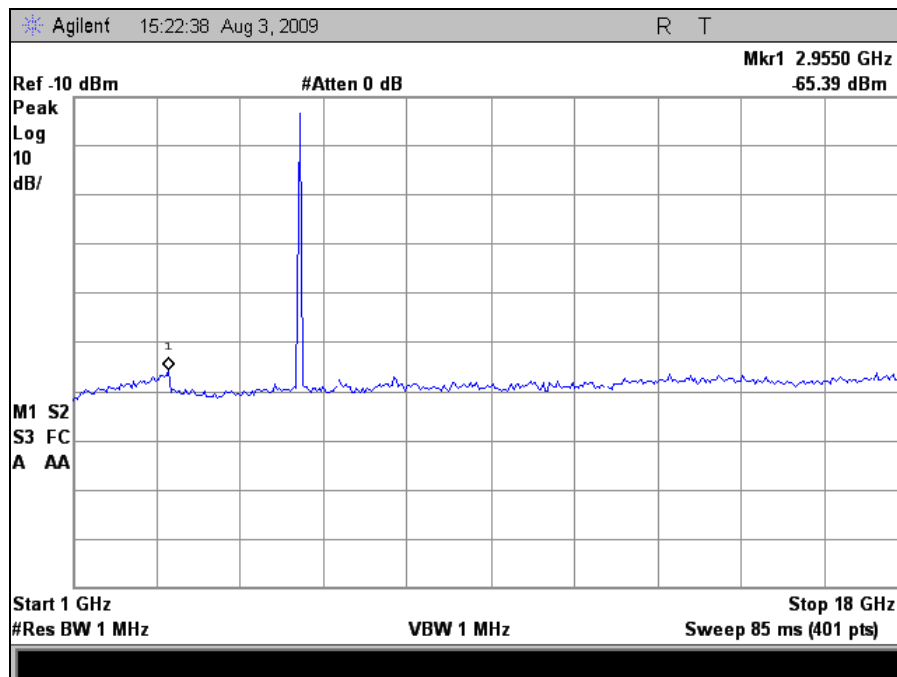

Plot 160. Radiated Spurious, 802.11n 20MHz, 5580 MHz, 1 GHz – 18 GHz, 16 dBi Sector

Radiated Spurious Emissions Test Results, 802.11n 20MHz (16dBi Sector Antenna)

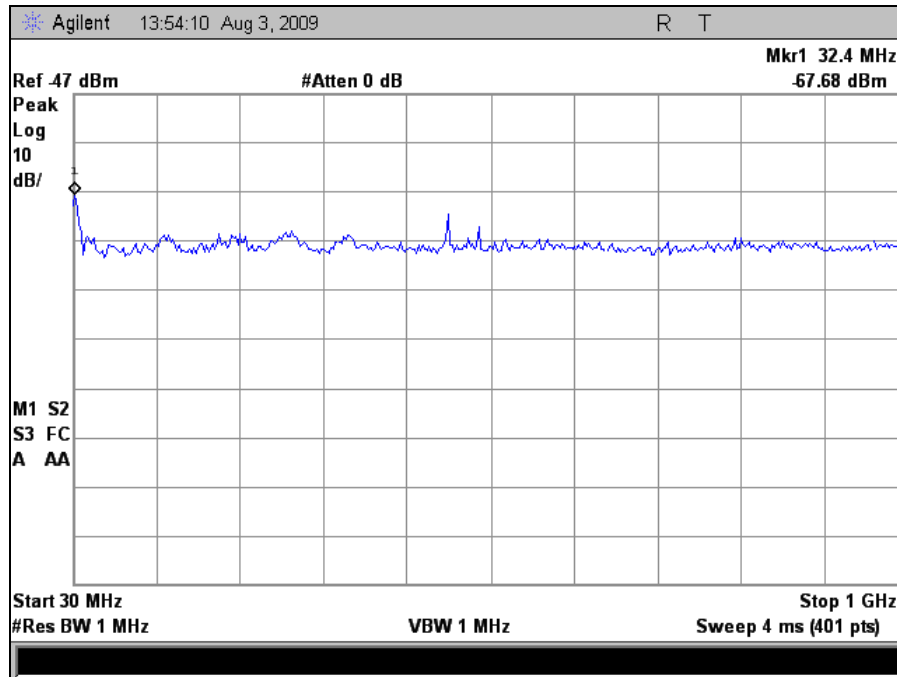

Plot 161. Radiated Spurious, 802.11n 20MHz, 5700 MHz, 30 MHz – 1 GHz, 16 dBi Sector

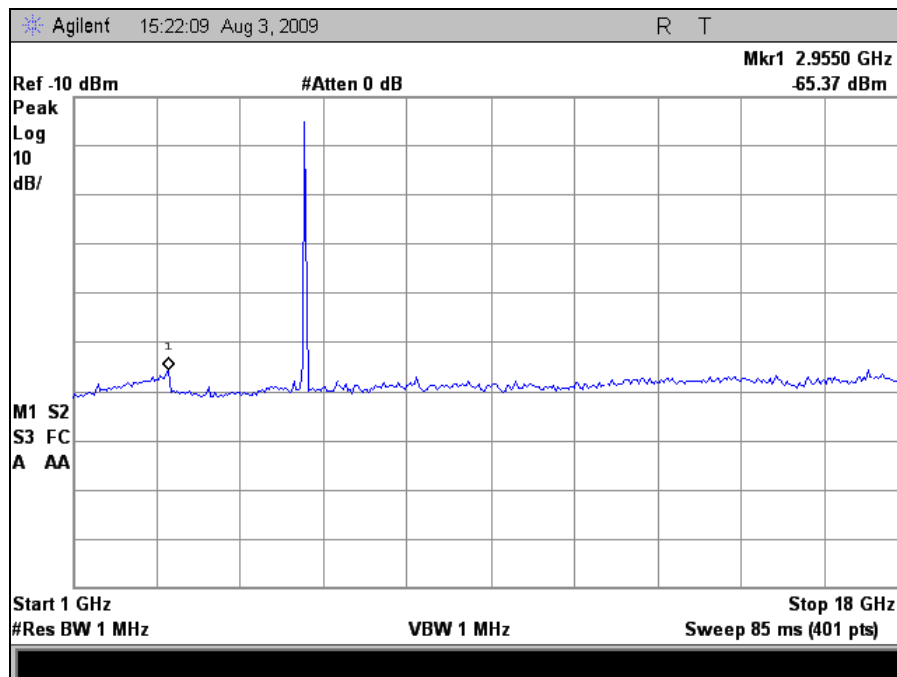

Plot 162. Radiated Spurious, 802.11n 20MHz, 5700 MHz, 1 GHz – 18 GHz, 16 dBi Sector

Radiated Spurious Emissions Test Results, 802.11n 20MHz (19dBi Panel Antenna)

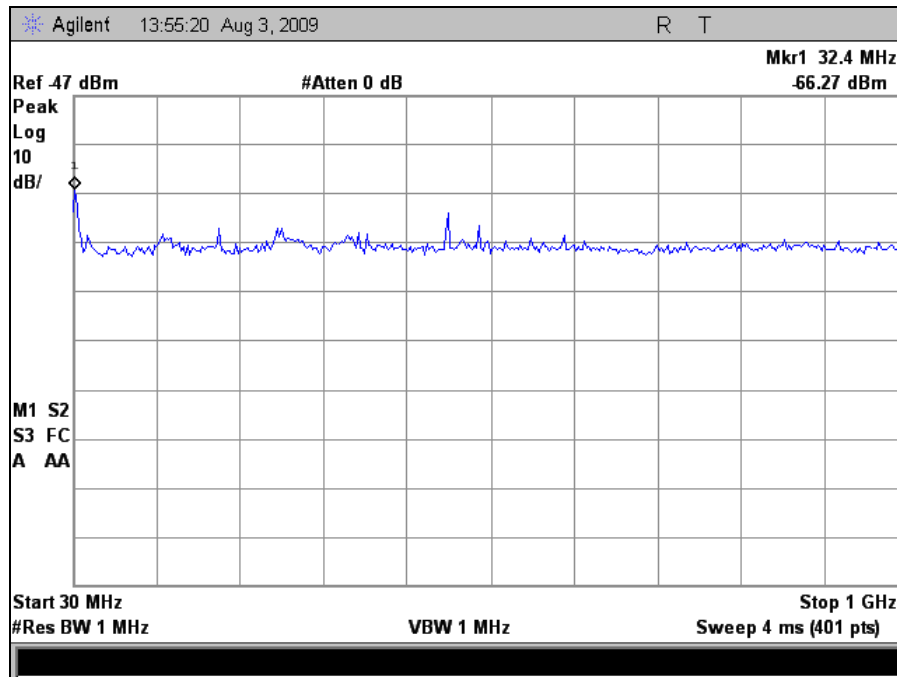

Plot 163. Radiated Spurious, 802.11n 20MHz, 5260 MHz, 30 MHz – 1 GHz, 19 dBi Panel

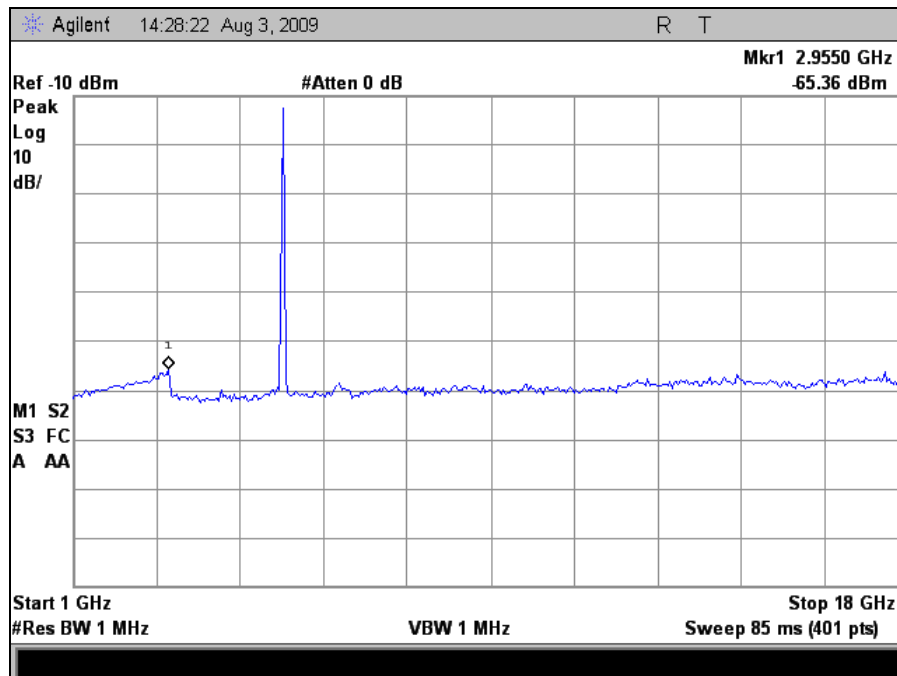

Plot 164. Radiated Spurious, 802.11n 20MHz, 5260 MHz, 1 GHz – 18 GHz, 19 dBi Panel

Radiated Spurious Emissions Test Results, 802.11n 20MHz (19dBi Panel Antenna)

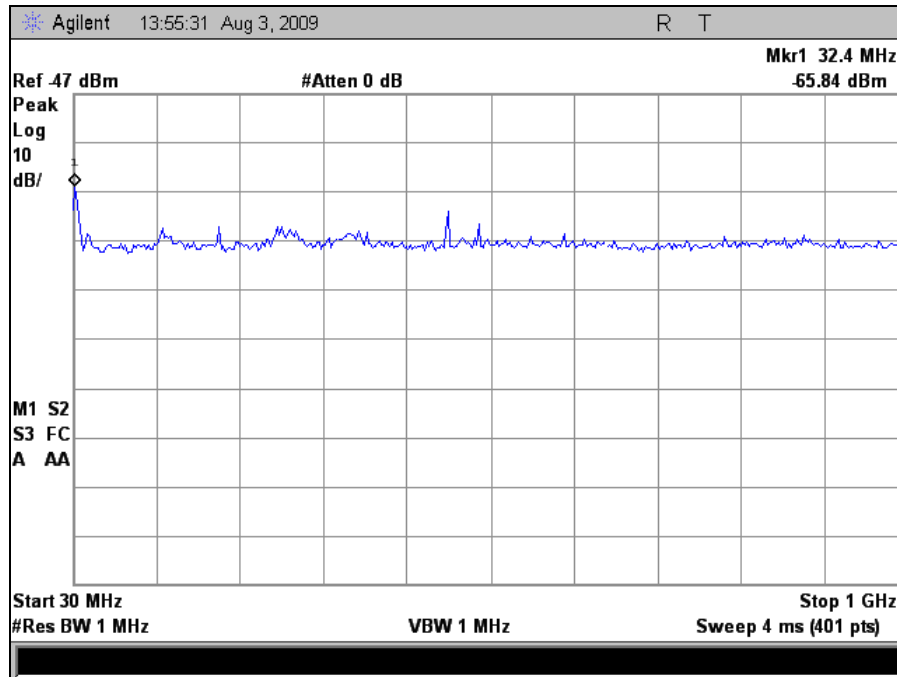

Plot 165. Radiated Spurious, 802.11n 20MHz, 5320 MHz, 30 MHz – 1 GHz, 19 dBi Panel

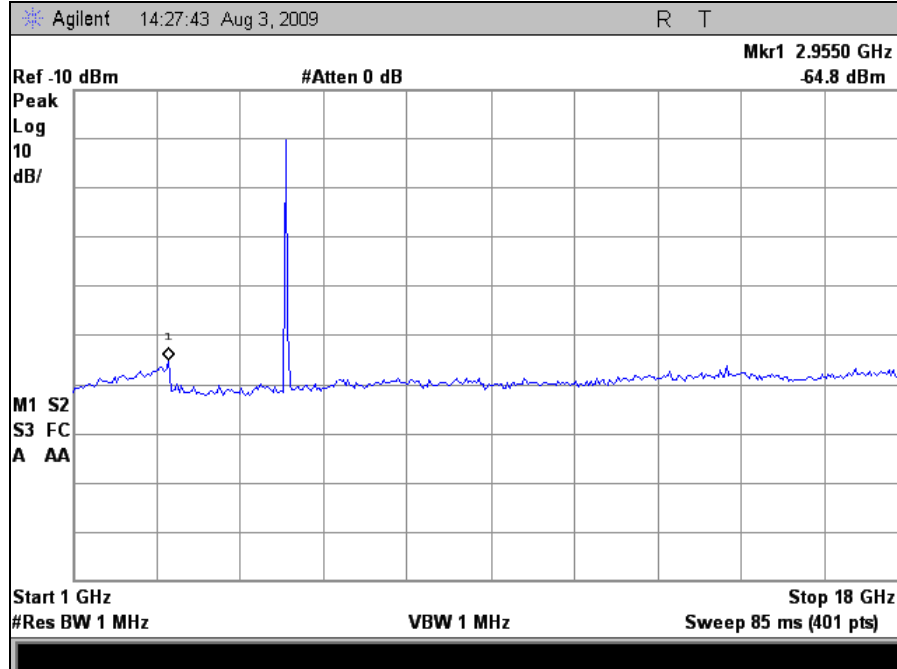

Plot 166. Radiated Spurious, 802.11n 20MHz, 5320 MHz, 1 GHz – 18 GHz, 19 dBi Panel

Radiated Spurious Emissions Test Results, 802.11n 20MHz (19dBi Panel Antenna)

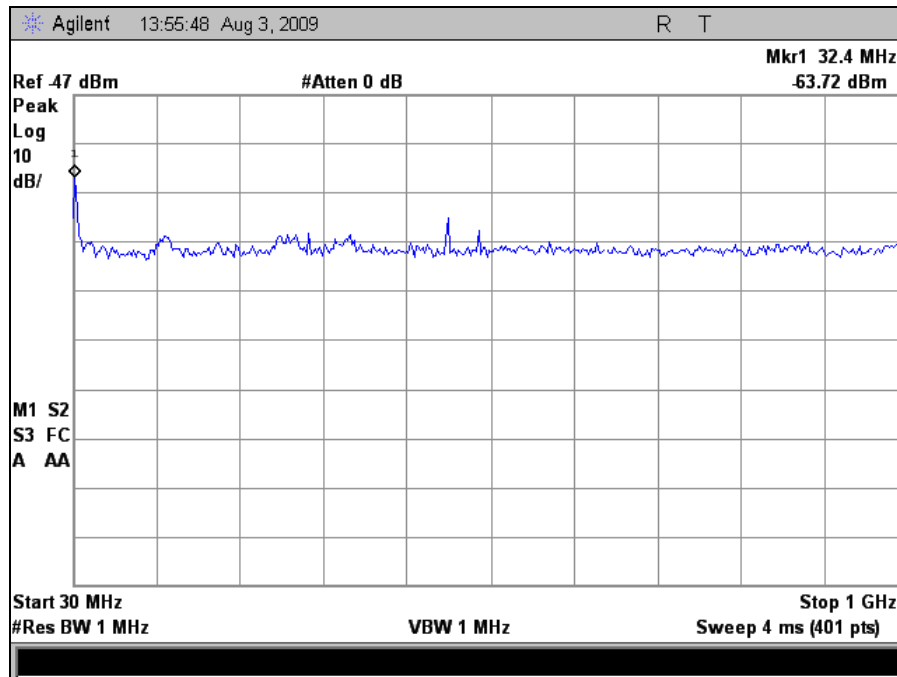

Plot 167. Radiated Spurious, 802.11n 20MHz, 5500 MHz, 30 MHz – 1 GHz, 19 dBi Panel

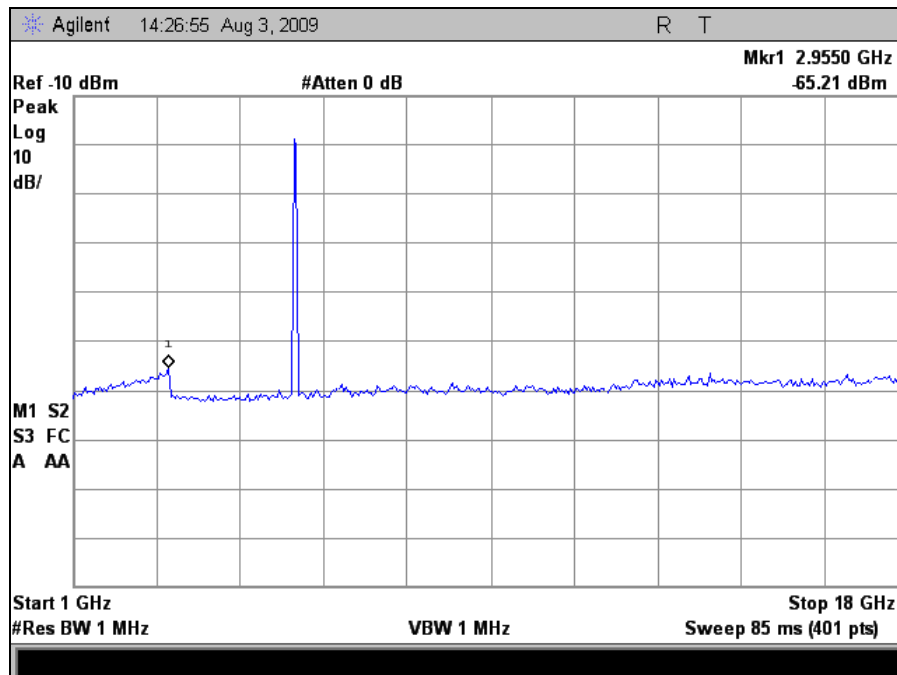

Plot 168. Radiated Spurious, 802.11n 20MHz, 5500 MHz, 1 GHz – 18 GHz, 19 dBi Panel

Radiated Spurious Emissions Test Results, 802.11n 20MHz (19dBi Panel Antenna)

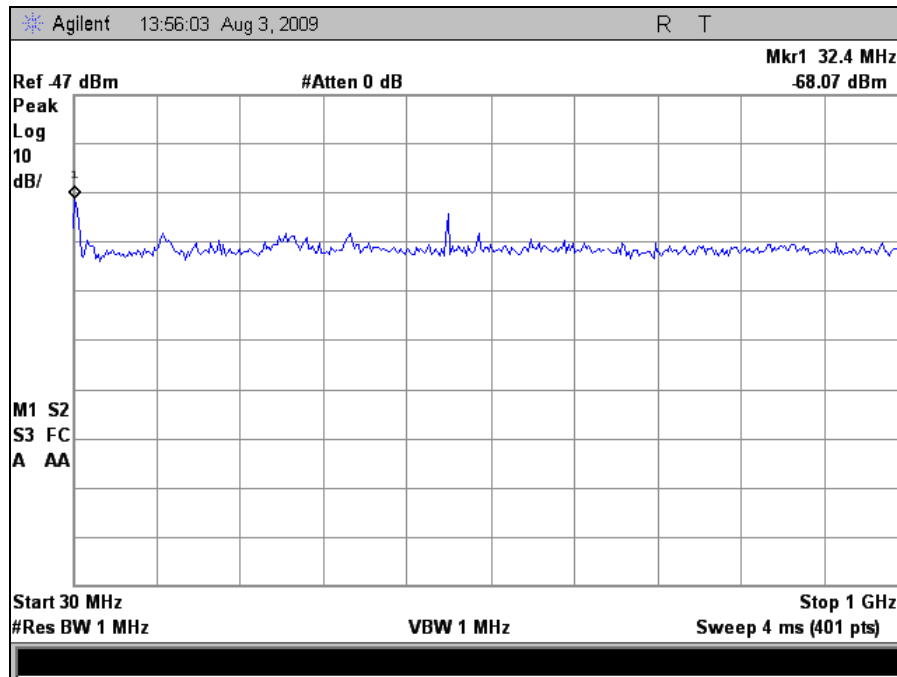

Plot 169. Radiated Spurious, 802.11n 20MHz, 5580 MHz, 30 MHz – 1 GHz, 19 dBi Panel

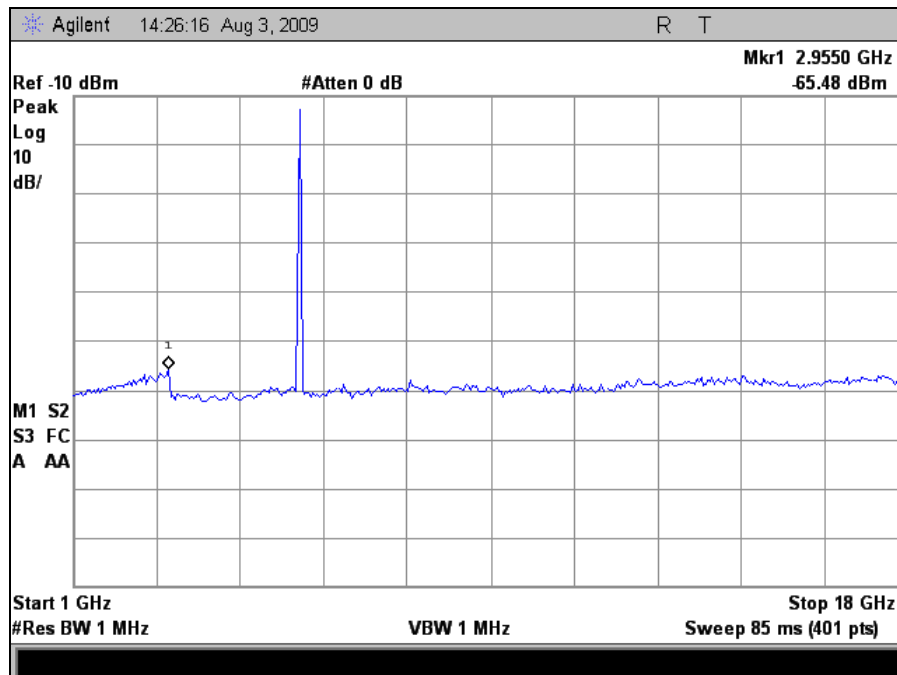

Plot 170. Radiated Spurious, 802.11n 20MHz, 5580 MHz, 1 GHz – 18 GHz, 19 dBi Panel

Radiated Spurious Emissions Test Results, 802.11n 20MHz (19dBi Panel Antenna)

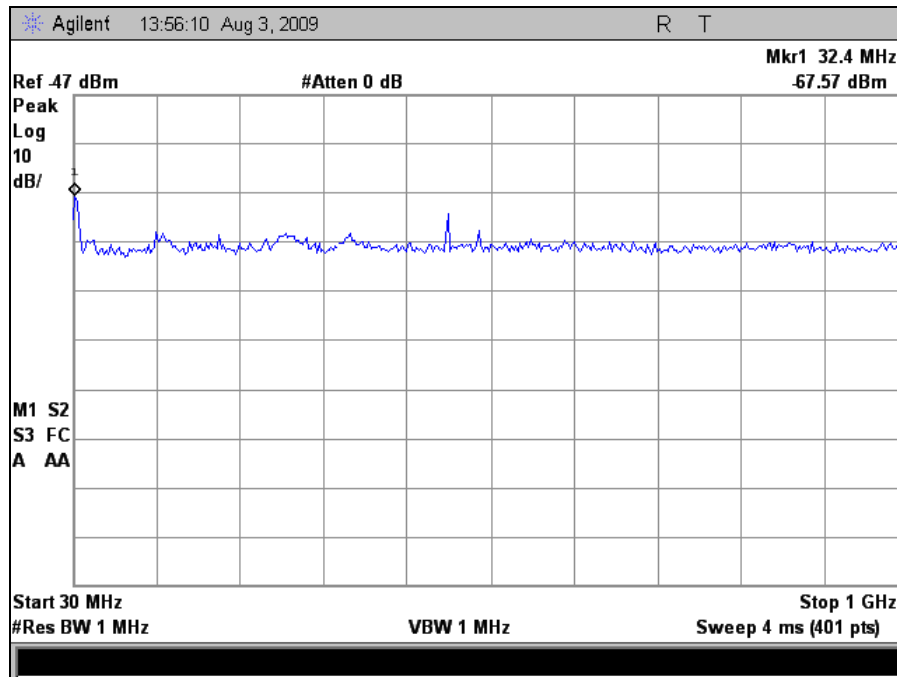

Plot 171. Radiated Spurious, 802.11n 20MHz, 5700 MHz, 30 MHz – 1 GHz, 19 dBi Panel

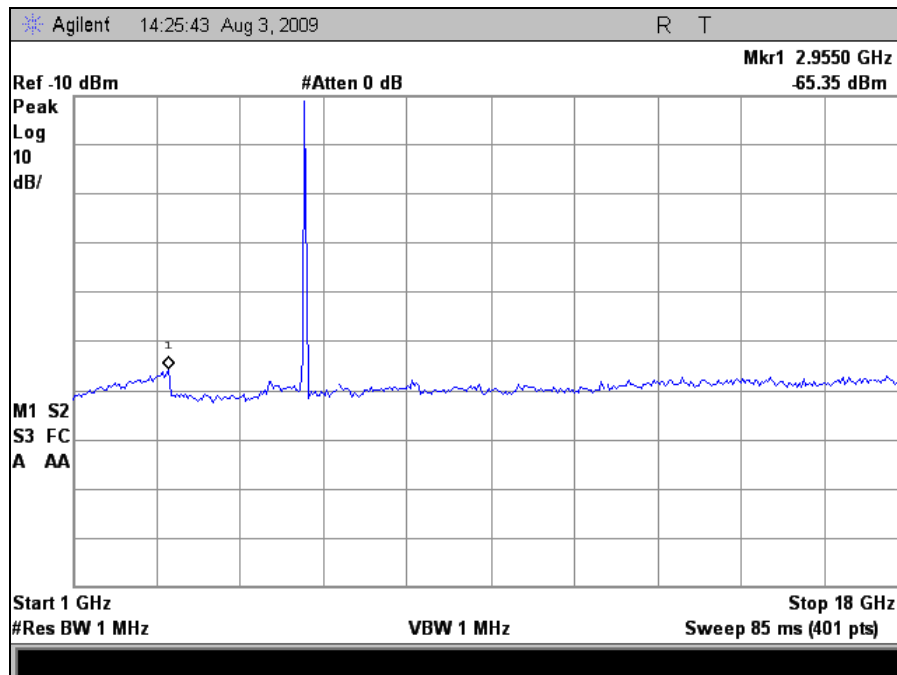

Plot 172. Radiated Spurious, 802.11n 20MHz, 5700 MHz, 1 GHz – 18 GHz, 19 dBi Panel

Radiated Spurious Emissions Test Results, 802.11n 40MHz (9dBi Omni Antenna)

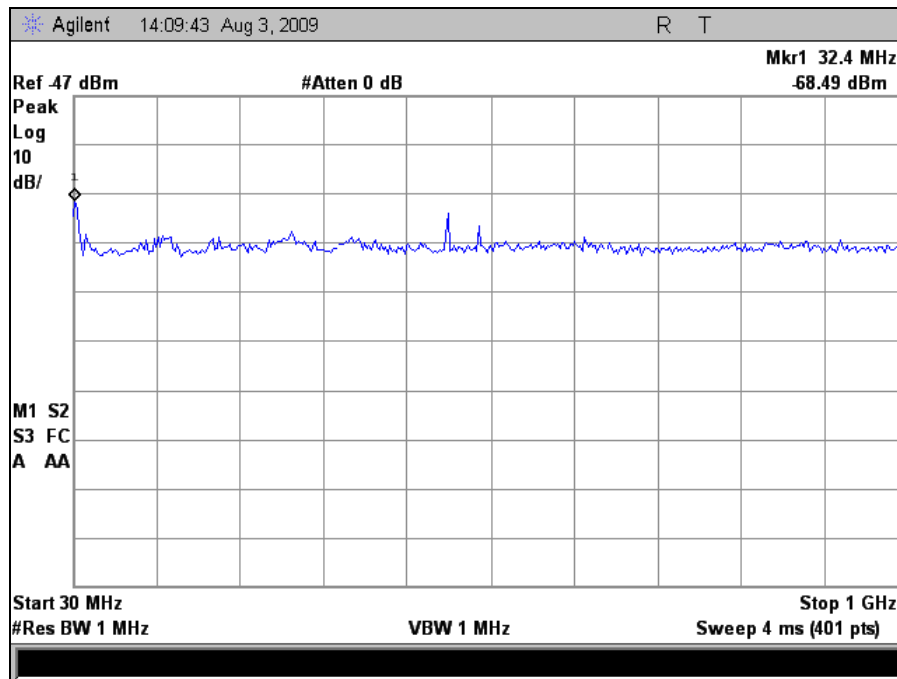

Plot 173. Radiated Spurious, 802.11n 40MHz, 5270 MHz, 30 MHz – 1 GHz, 9 dBi Omni

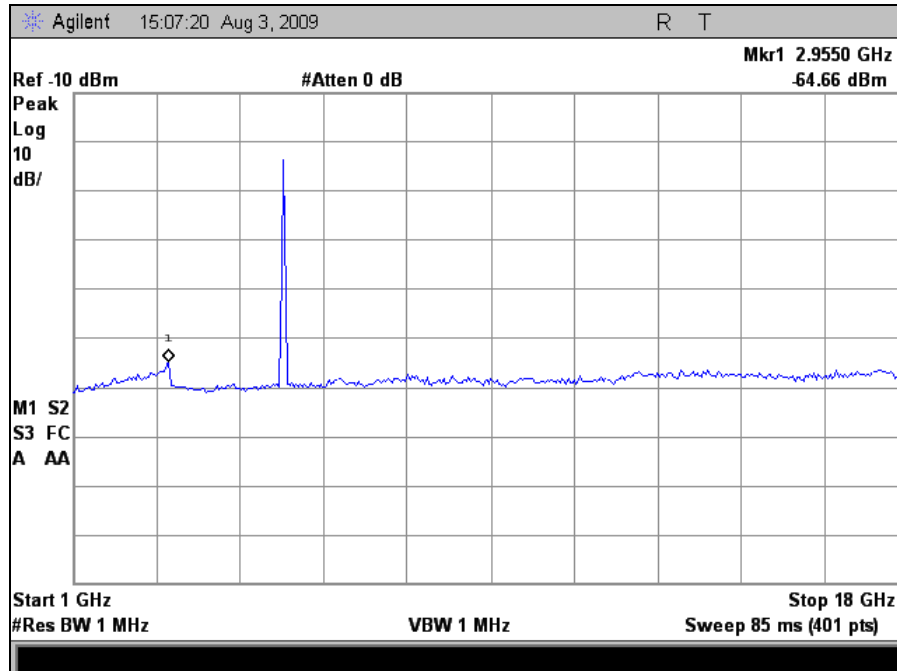

Plot 174. Radiated Spurious, 802.11n 40MHz, 5270 MHz, 1 GHz – 18 GHz, 9 dBi Omni

Radiated Spurious Emissions Test Results, 802.11n 40MHz (9dBi Omni Antenna)

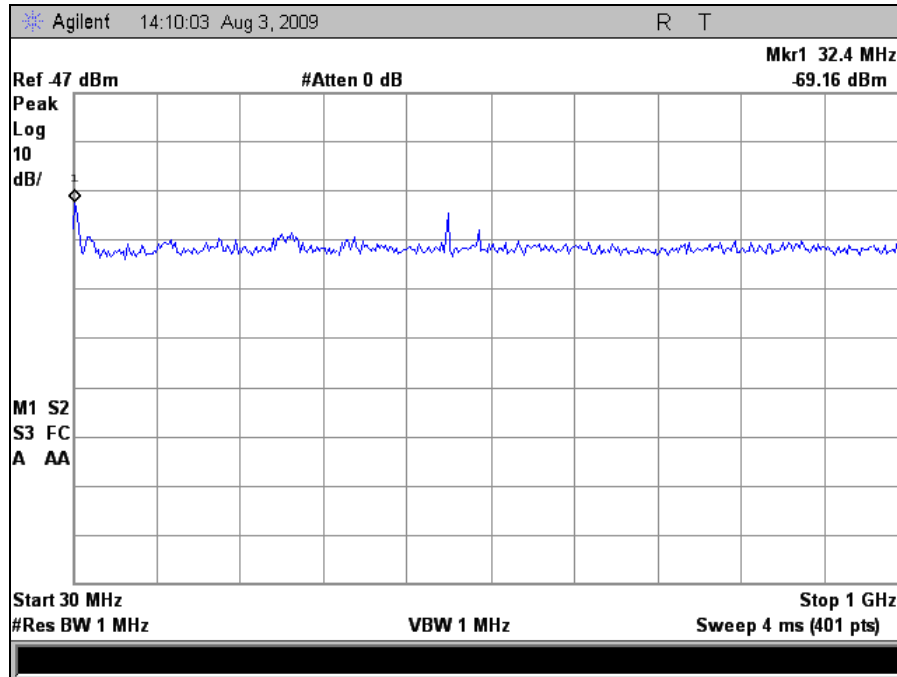

Plot 175. Radiated Spurious, 802.11n 40MHz, 5310 MHz, 30 MHz – 1 GHz, 9 dBi Omni

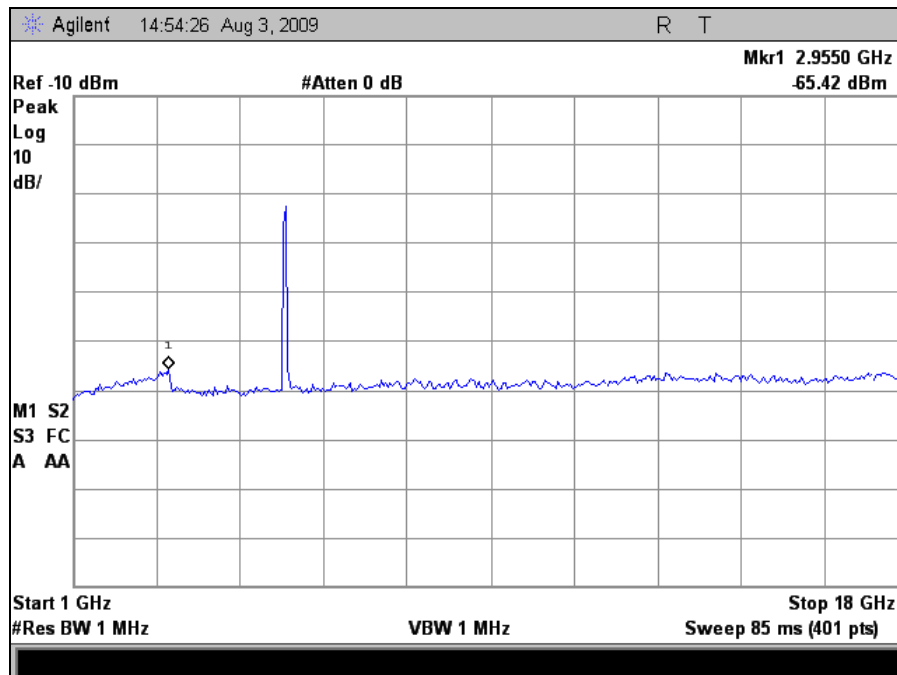

Plot 176. Radiated Spurious, 802.11n 40MHz, 5310 MHz, 1 GHz – 18 GHz, 9 dBi Omni

Radiated Spurious Emissions Test Results, 802.11n 40MHz (9dBi Omni Antenna)

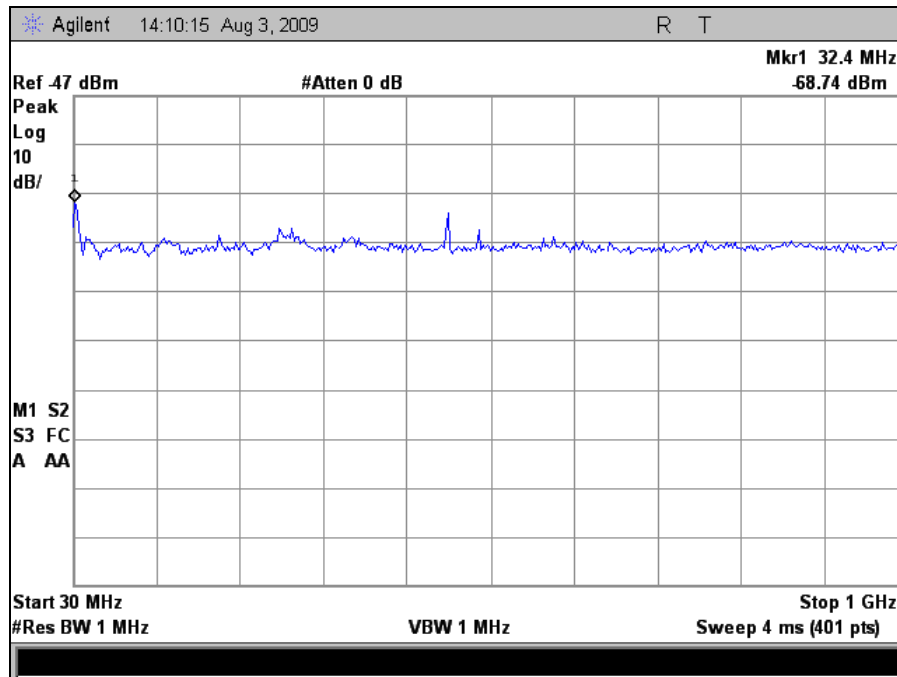

Plot 177. Radiated Spurious, 802.11n 40MHz, 5510 MHz, 30 MHz – 1 GHz, 9 dBi Omni

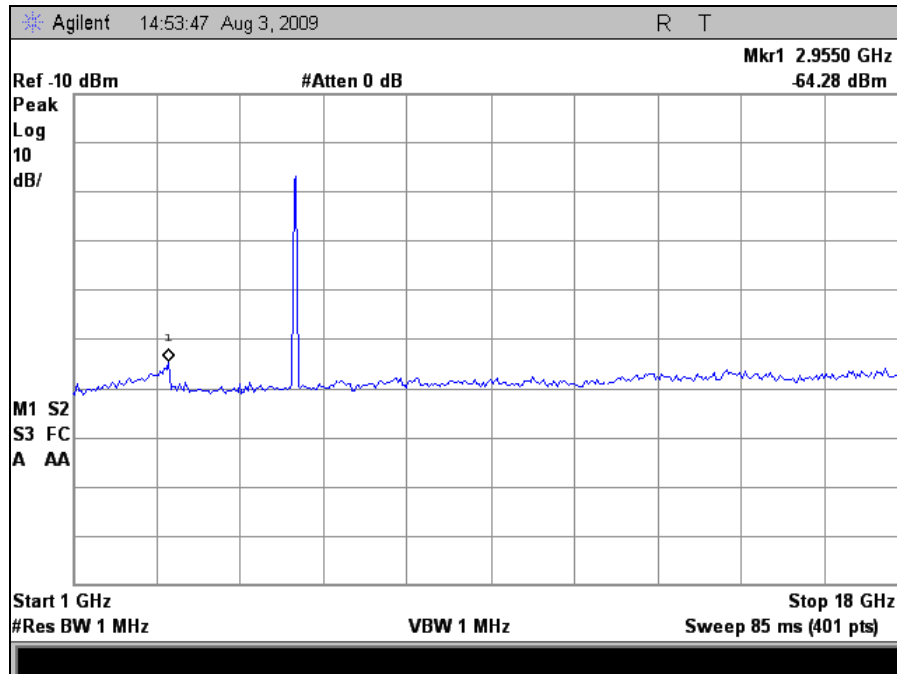

Plot 178. Radiated Spurious, 802.11n 40MHz, 5510 MHz, 1 GHz – 18 GHz, 9 dBi Omni

Radiated Spurious Emissions Test Results, 802.11n 40MHz (9dBi Omni Antenna)

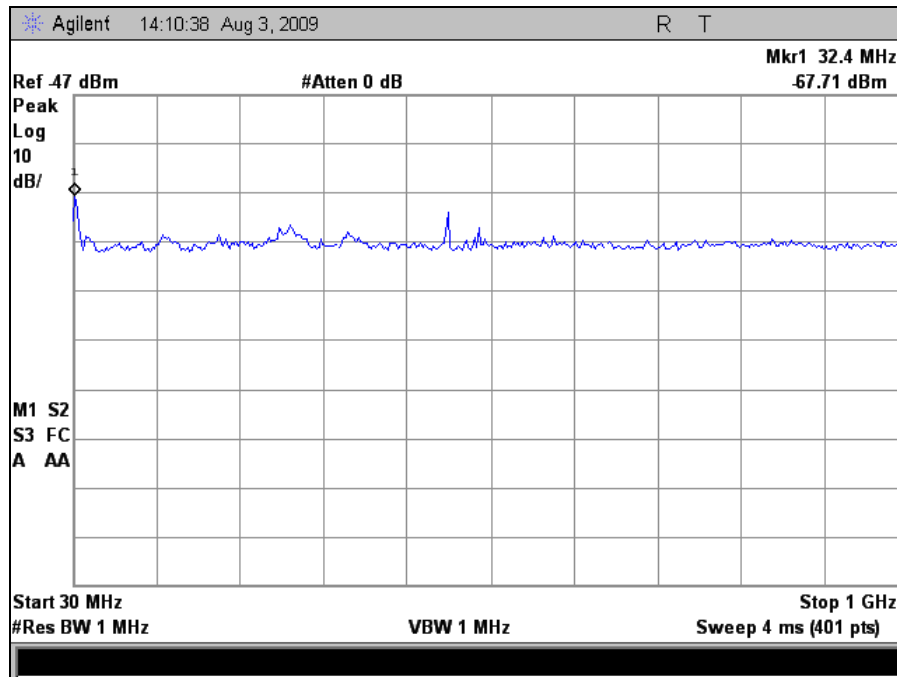

Plot 179. Radiated Spurious, 802.11n 40MHz, 5550 MHz, 30 MHz – 1 GHz, 9 dBi Omni

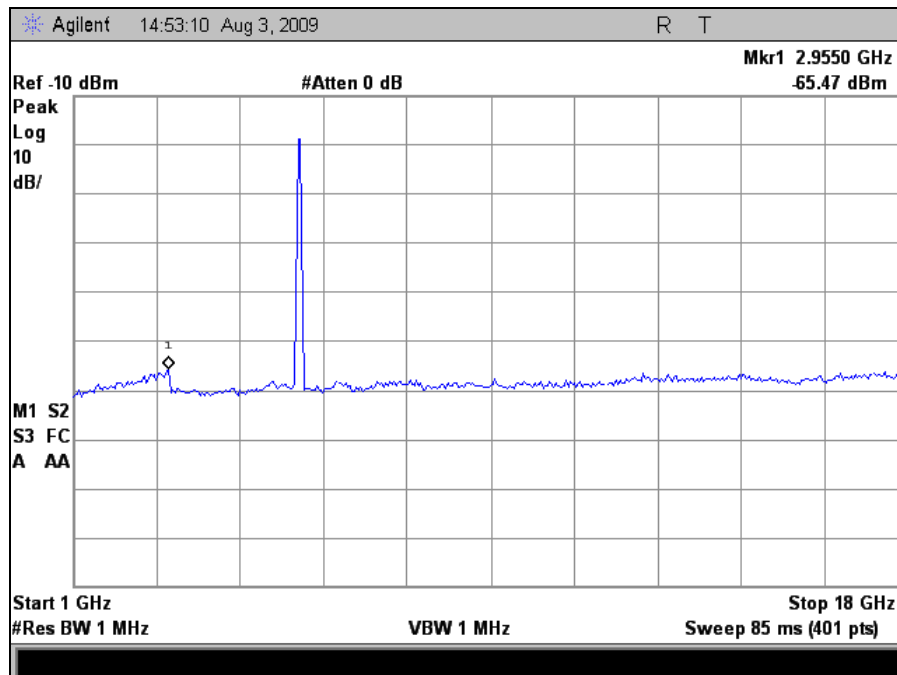

Plot 180. Radiated Spurious, 802.11n 40MHz, 5550 MHz, 1 GHz – 18 GHz, 9 dBi Omni

Radiated Spurious Emissions Test Results, 802.11n 40MHz (9dBi Omni Antenna)

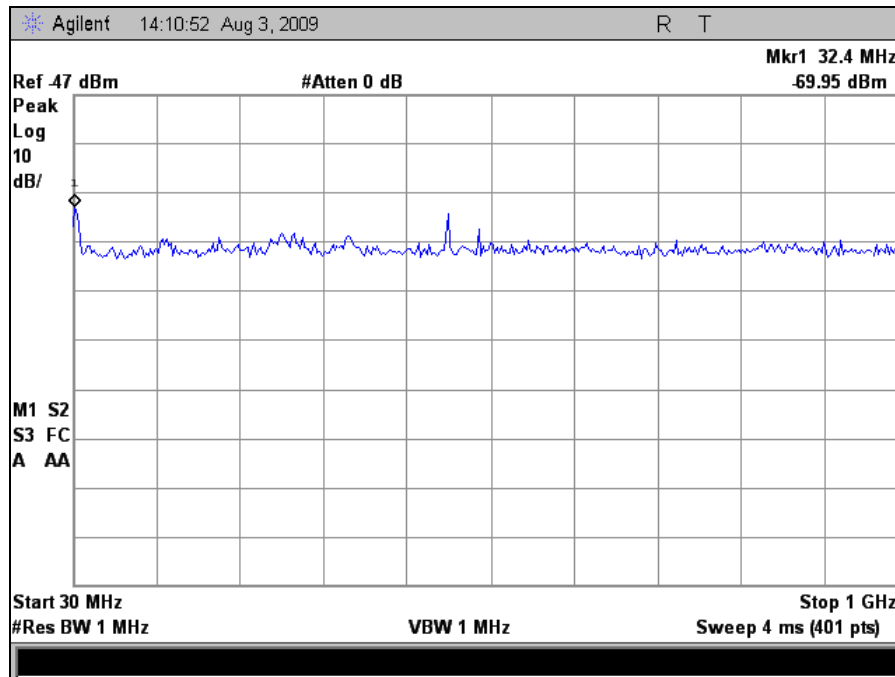

Plot 181. Radiated Spurious, 802.11n 40MHz, 5670 MHz, 30 MHz – 1 GHz, 9 dBi Omni

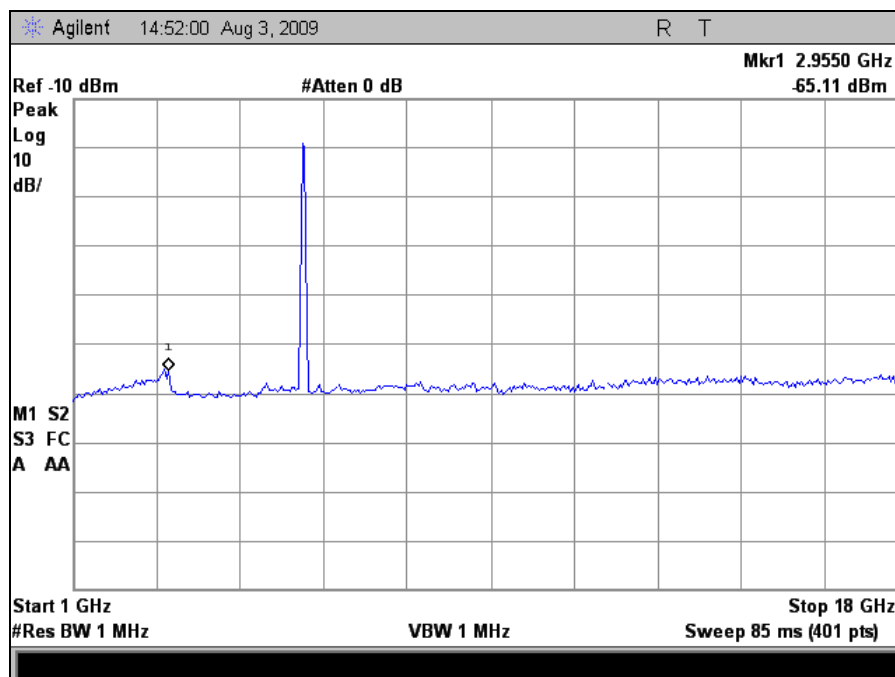

Plot 182. Radiated Spurious, 802.11n 40MHz, 5670 MHz, 1 GHz – 18 GHz, 9 dBi Omni

Radiated Spurious Emissions Test Results, 802.11n 40MHz (16dBi Sector Antenna)

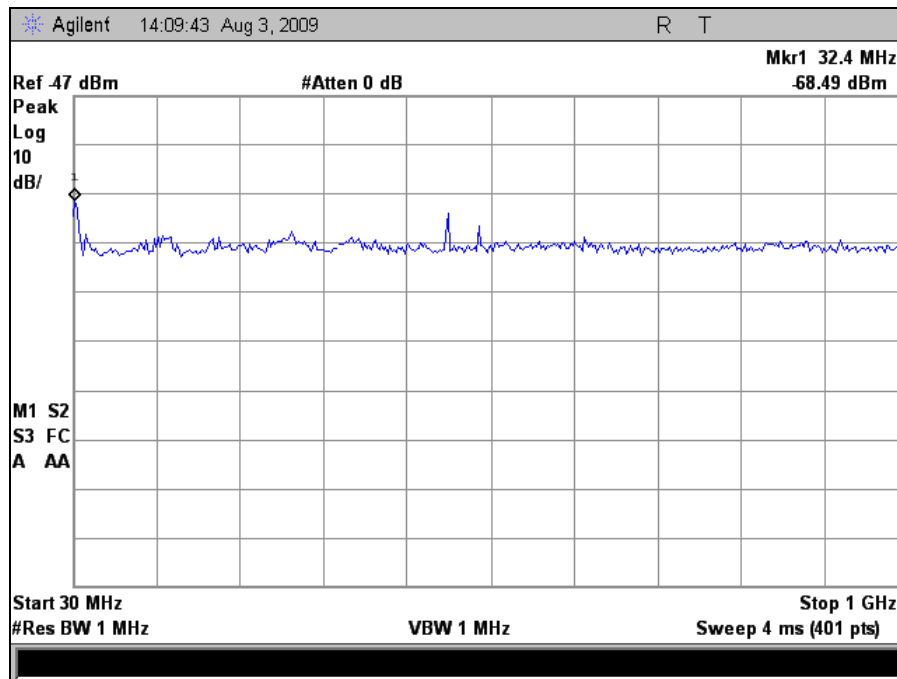

Plot 183. Radiated Spurious, 802.11n 40MHz, 5270 MHz, 30 MHz – 1 GHz, 16 dBi Sector

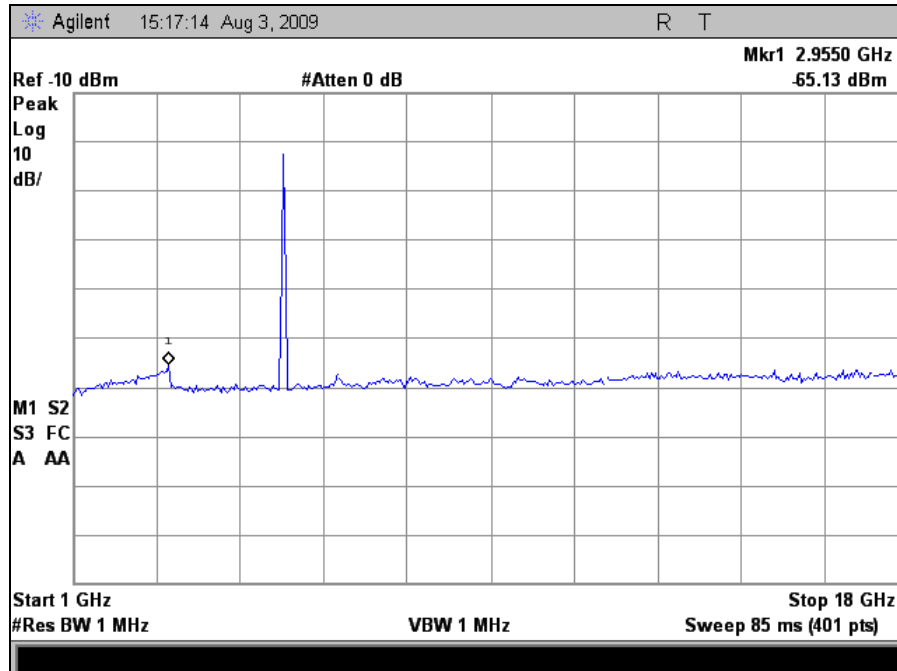

Plot 184. Radiated Spurious, 802.11n 40MHz, 5270 MHz, 1 GHz – 18 GHz, 16 dBi Sector

Radiated Spurious Emissions Test Results, 802.11n 40MHz (16dBi Sector Antenna)

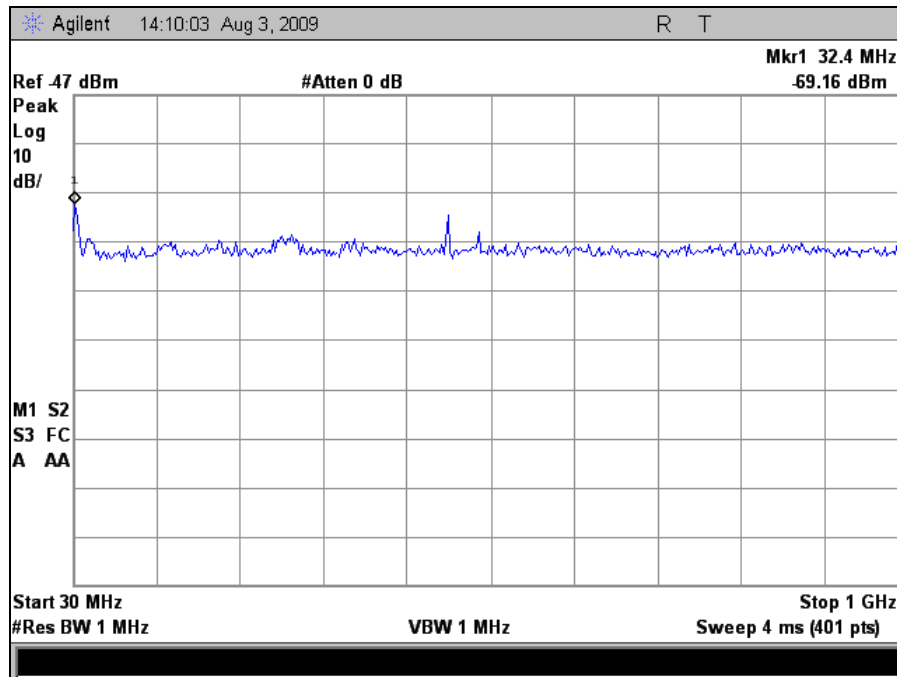

Plot 185. Radiated Spurious, 802.11n 40MHz, 5310 MHz, 30 MHz – 1 GHz, 16 dBi Sector

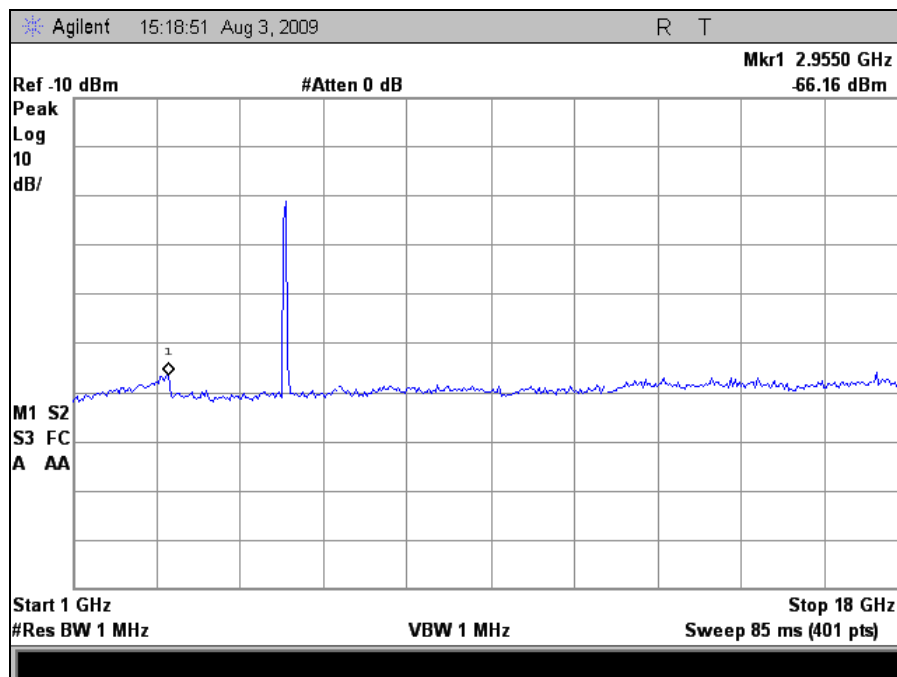

Plot 186. Radiated Spurious, 802.11n 40MHz, 5310 MHz, 1 GHz – 18 GHz, 16 dBi Sector

Radiated Spurious Emissions Test Results, 802.11n 40MHz (16dBi Sector Antenna)

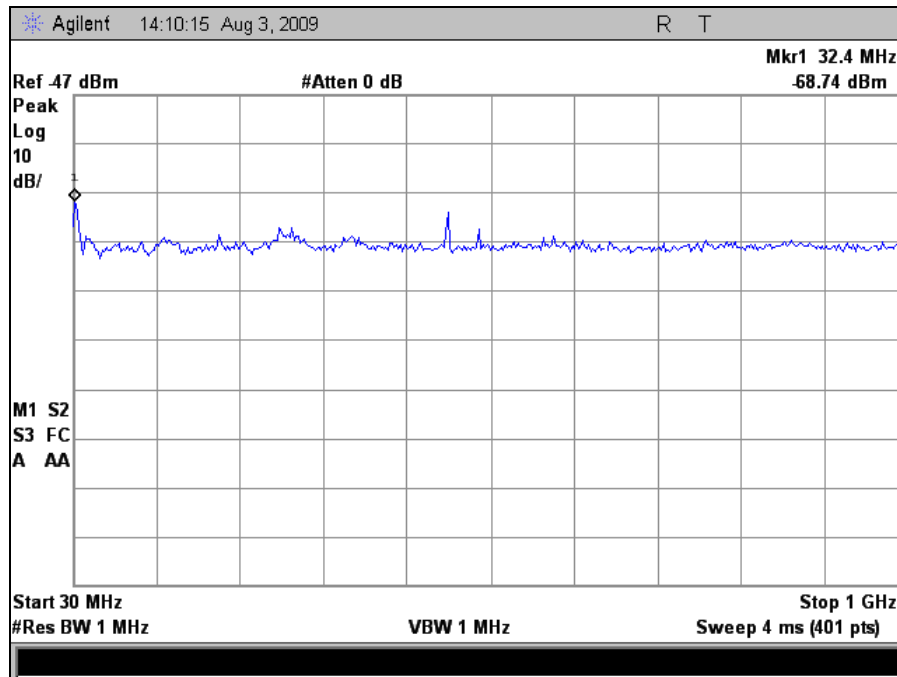

Plot 187. Radiated Spurious, 802.11n 40MHz, 5510 MHz, 30 MHz – 1 GHz, 16 dBi Sector

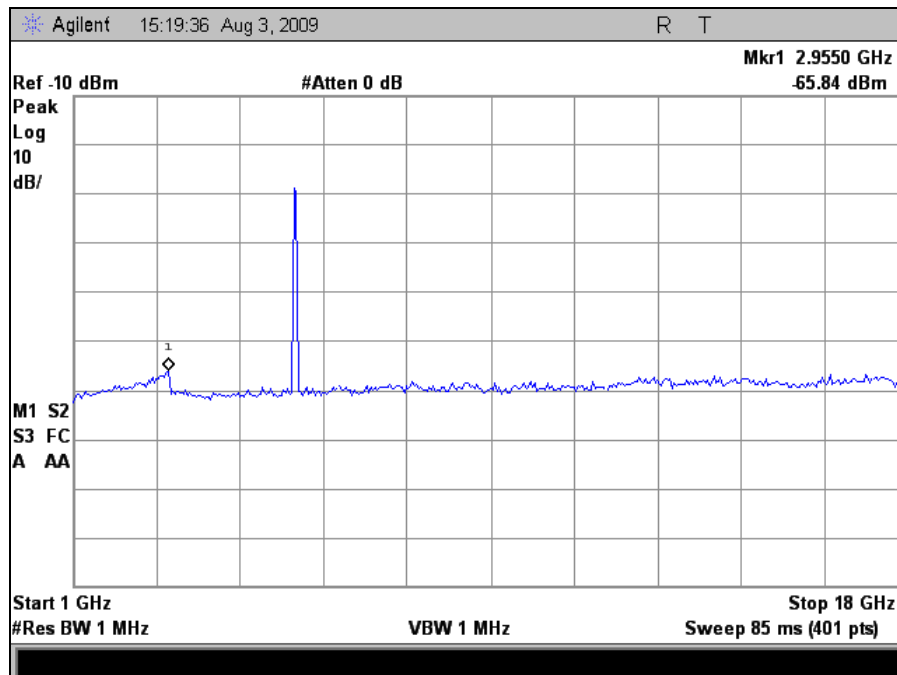

Plot 188. Radiated Spurious, 802.11n 40MHz, 5510 MHz, 1 GHz – 18 GHz, 16 dBi Sector

Radiated Spurious Emissions Test Results, 802.11n 40MHz (16dBi Sector Antenna)

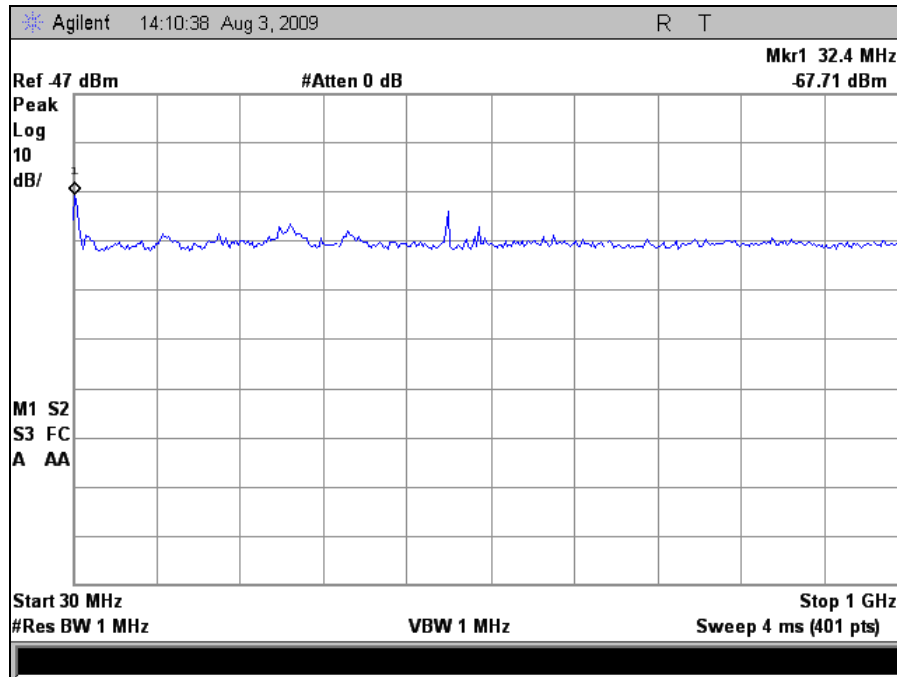

Plot 189. Radiated Spurious, 802.11n 40MHz, 5550 MHz, 30 MHz – 1 GHz, 16 dBi Sector

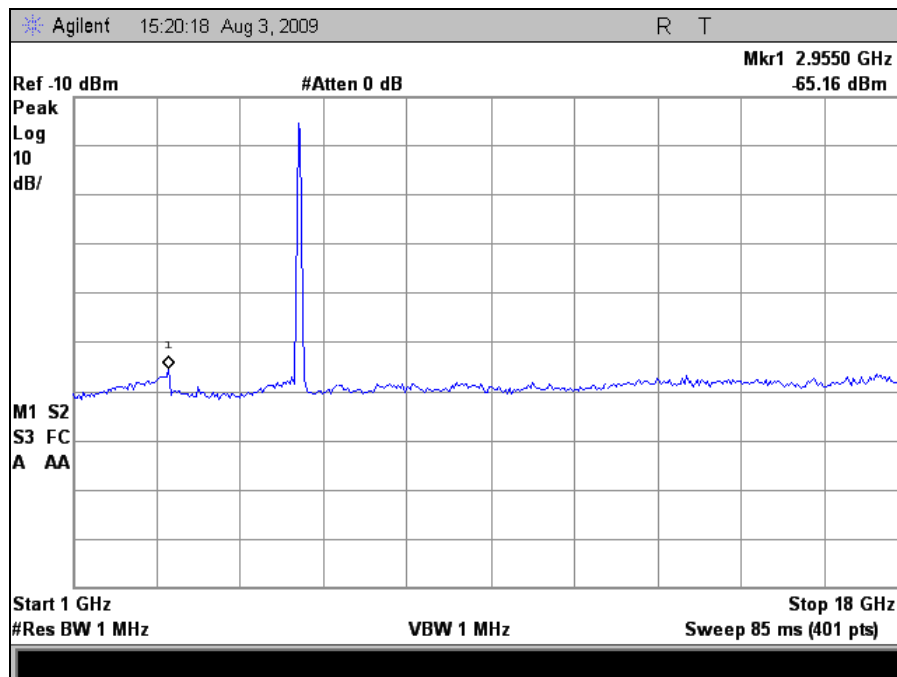

Plot 190. Radiated Spurious, 802.11n 40MHz, 5550 MHz, 1 GHz – 18 GHz, 16 dBi Sector

Radiated Spurious Emissions Test Results, 802.11n 40MHz (16dBi Sector Antenna)

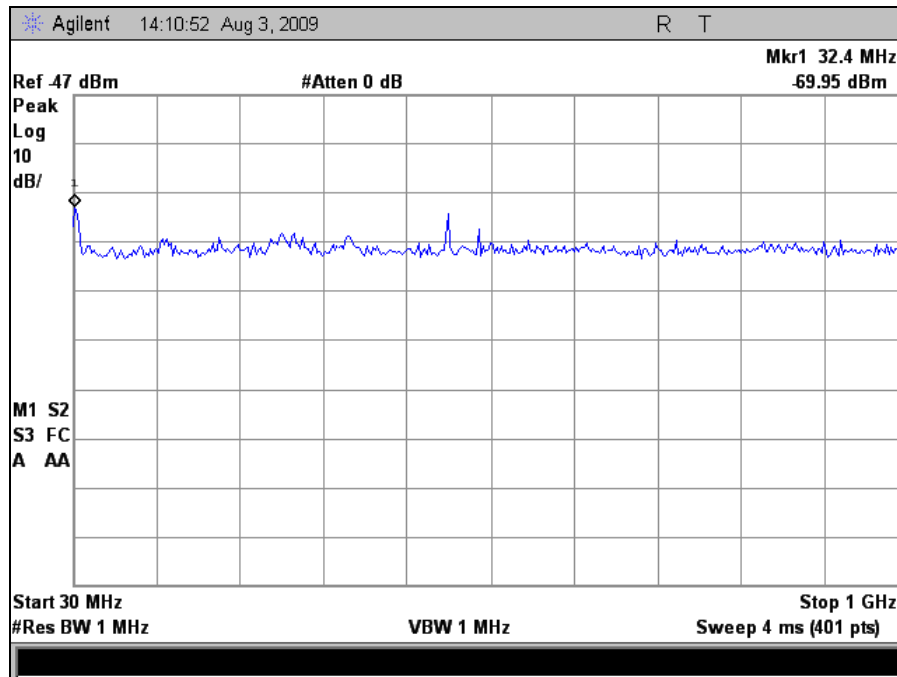

Plot 191. Radiated Spurious, 802.11n 40MHz, 5670 MHz, 30 MHz – 1 GHz, 16 dBi Sector

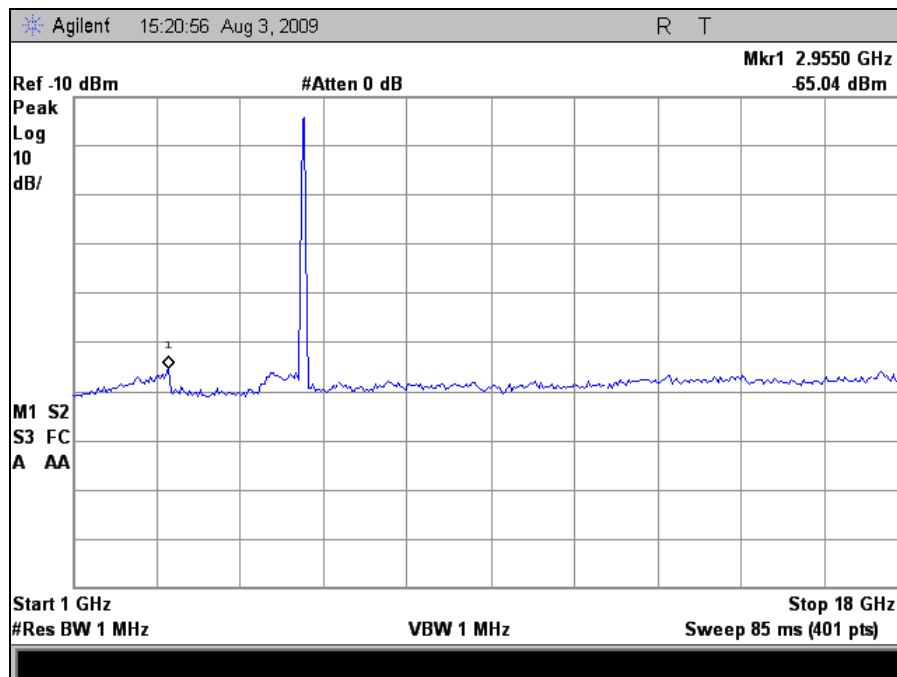

Plot 192. Radiated Spurious, 802.11n 40MHz, 5670 MHz, 1 GHz – 18 GHz, 16 dBi Sector

Radiated Spurious Emissions Test Results, 802.11n 40MHz (19dBi Panel Antenna)

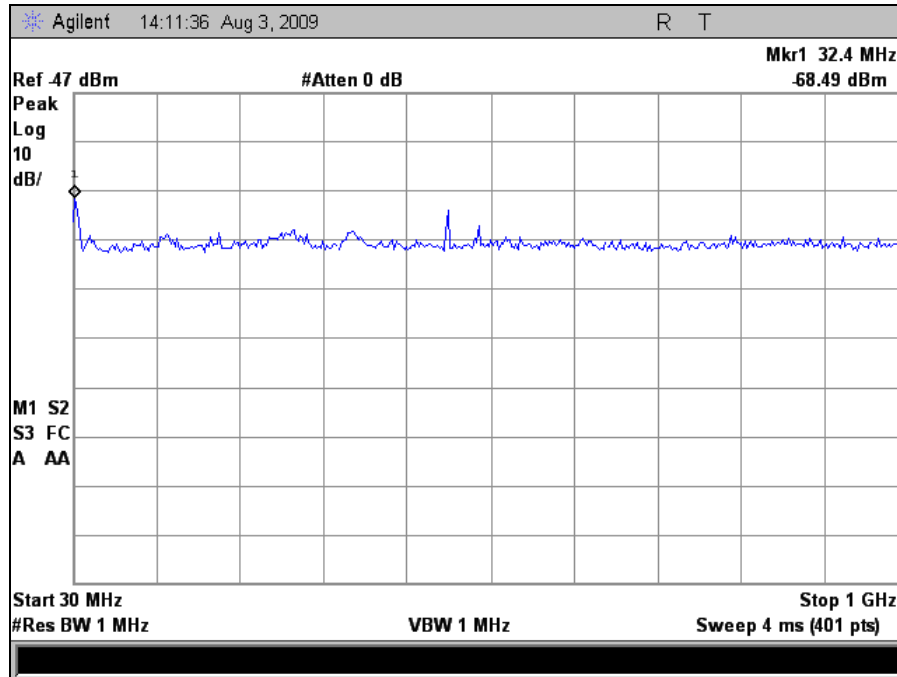

Plot 193. Radiated Spurious, 802.11n 40MHz, 5270 MHz, 30 MHz – 1 GHz, 19 dBi Panel

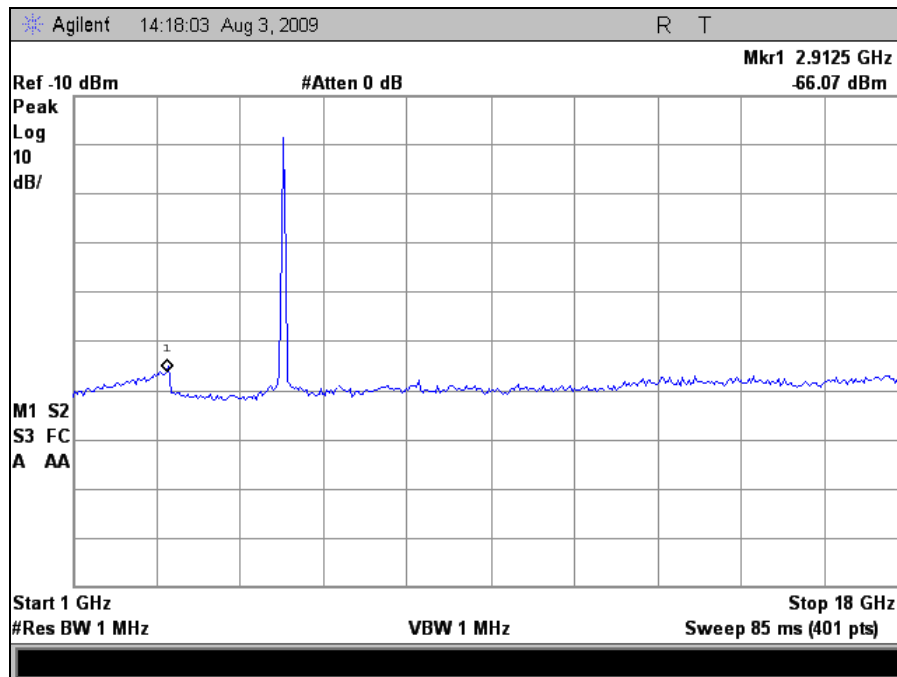

Plot 194. Radiated Spurious, 802.11n 40MHz, 5270 MHz, 1 GHz – 18 GHz, 19 dBi Panel

Radiated Spurious Emissions Test Results, 802.11n 40MHz (19dBi Panel Antenna)

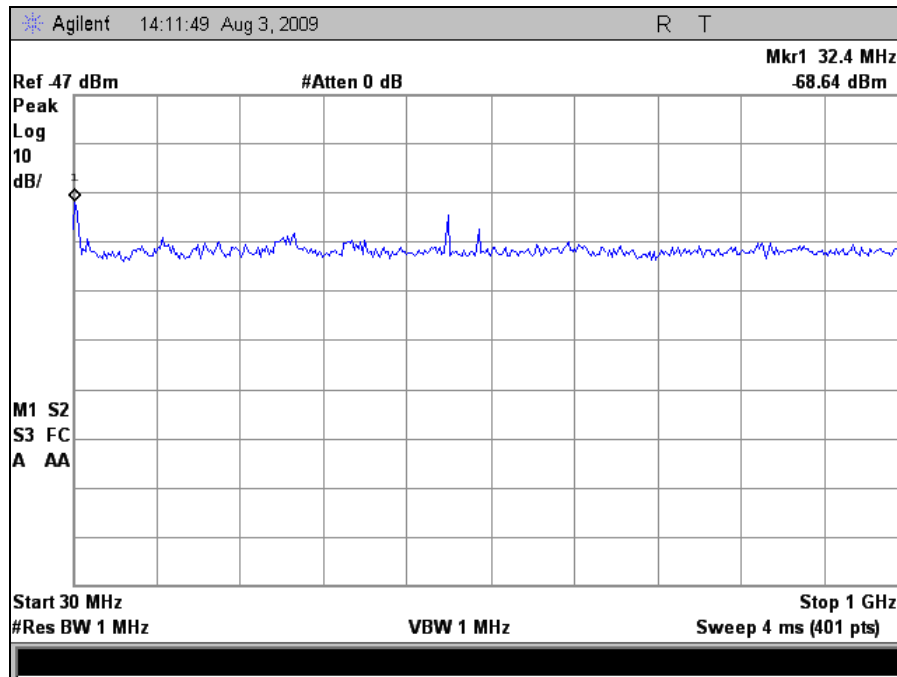

Plot 195. Radiated Spurious, 802.11n 40MHz, 5310 MHz, 30 MHz – 1 GHz, 19 dBi Panel

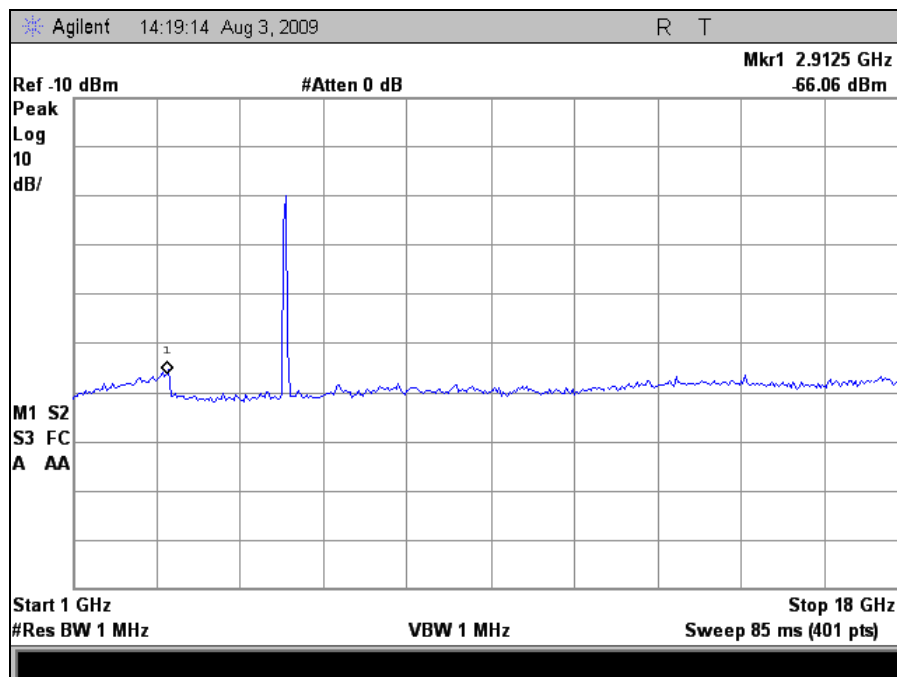

Plot 196. Radiated Spurious, 802.11n 40MHz, 5310 MHz, 1 GHz – 18 GHz, 19 dBi Panel

Radiated Spurious Emissions Test Results, 802.11n 40MHz (19dBi Panel Antenna)

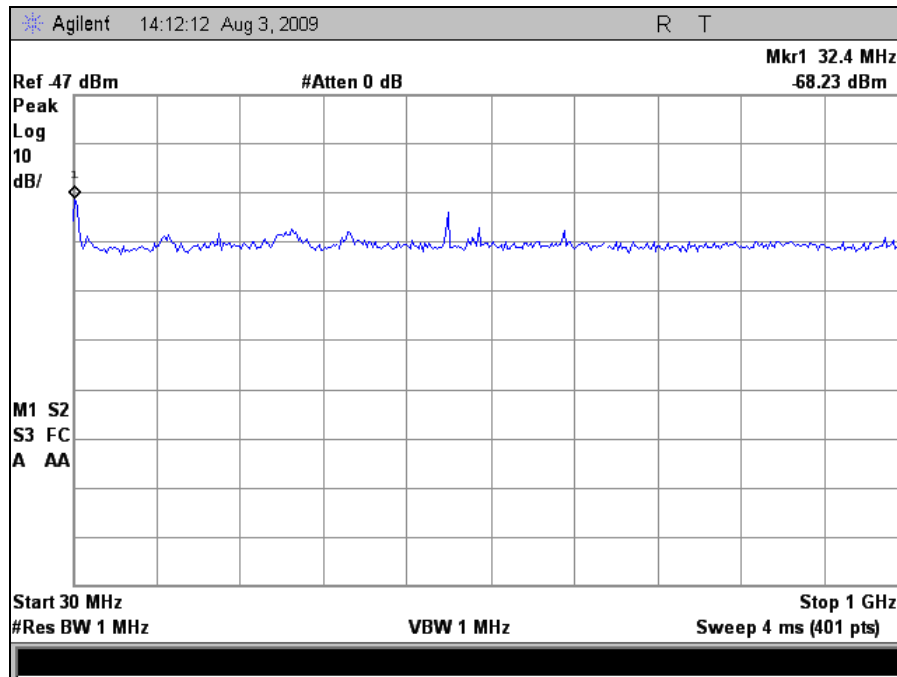

Plot 197. Radiated Spurious, 802.11n 40MHz, 5510 MHz, 30 MHz – 1 GHz, 19 dBi Panel

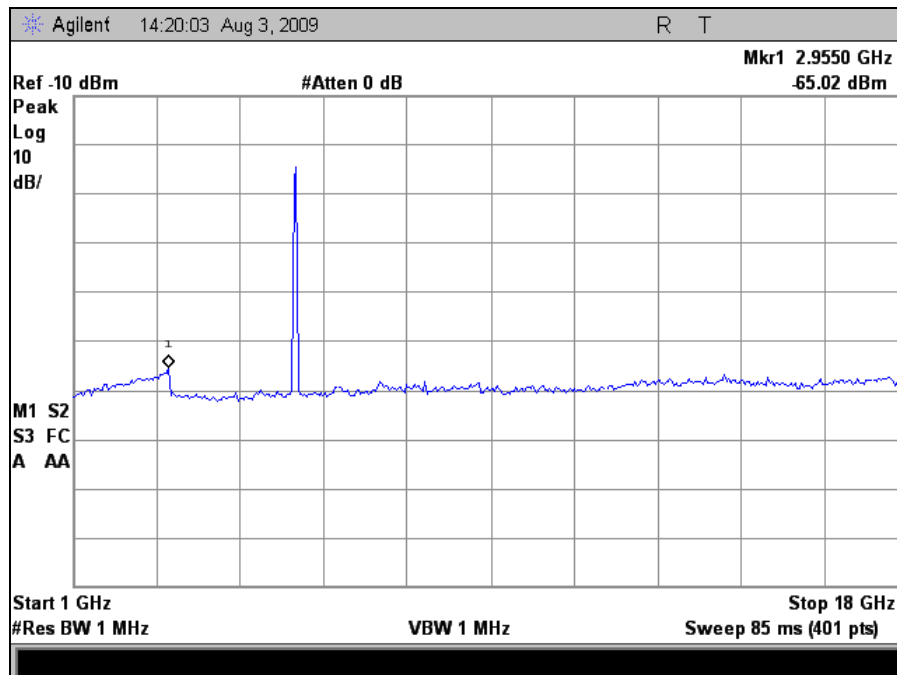

Plot 198. Radiated Spurious, 802.11n 40MHz, 5510 MHz, 1 GHz – 18 GHz, 19 dBi Panel

Radiated Spurious Emissions Test Results, 802.11n 40MHz (19dBi Panel Antenna)

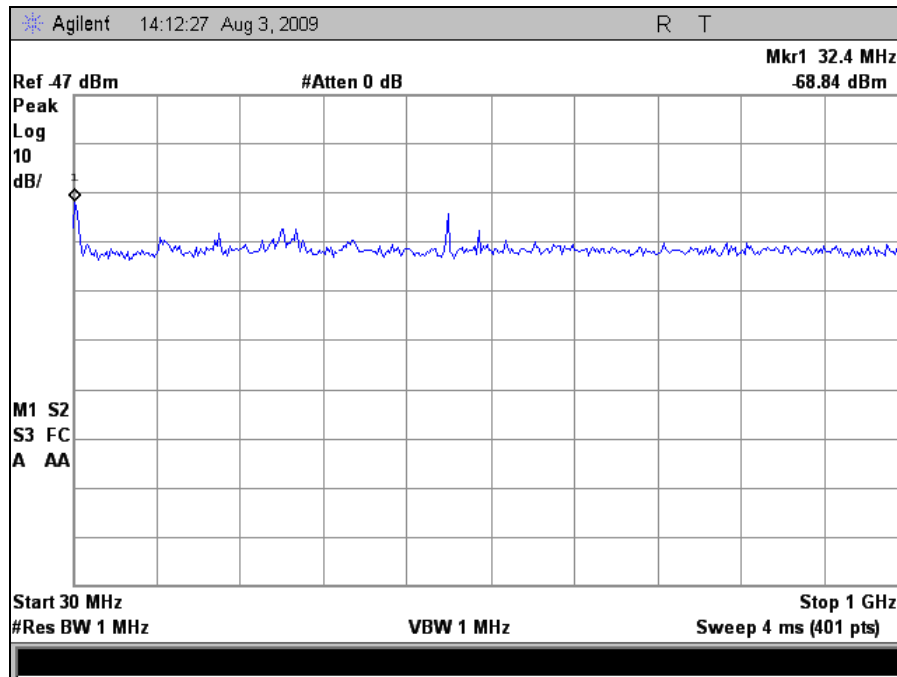

Plot 199. Radiated Spurious, 802.11n 40MHz, 5550 MHz, 30 MHz – 1 GHz, 19 dBi Panel

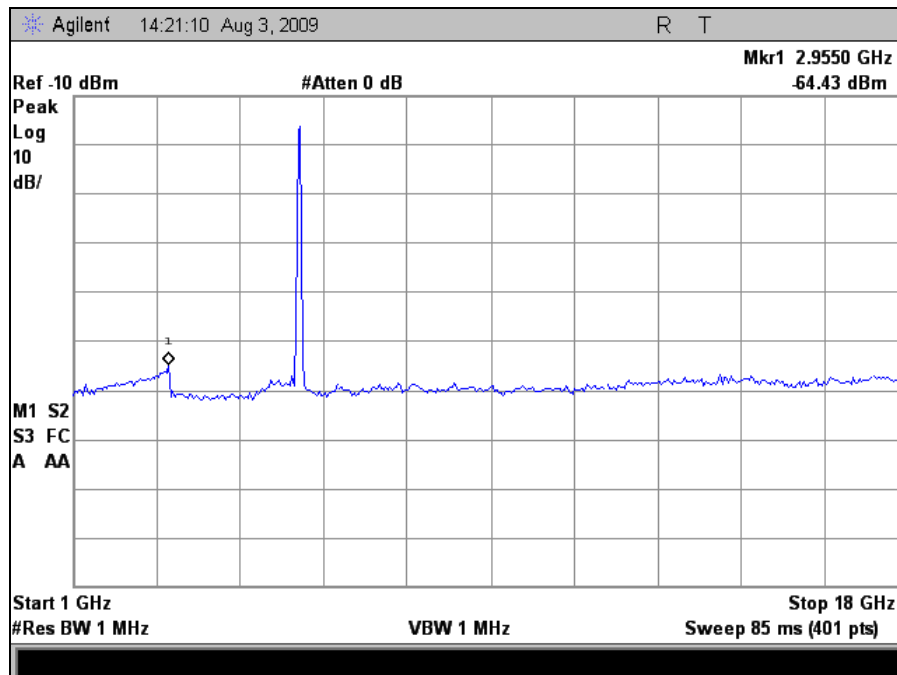

Plot 200. Radiated Spurious, 802.11n 40MHz, 5550 MHz, 1 GHz – 18 GHz, 19 dBi Panel

Radiated Spurious Emissions Test Results, 802.11n 40MHz (19dBi Panel Antenna)

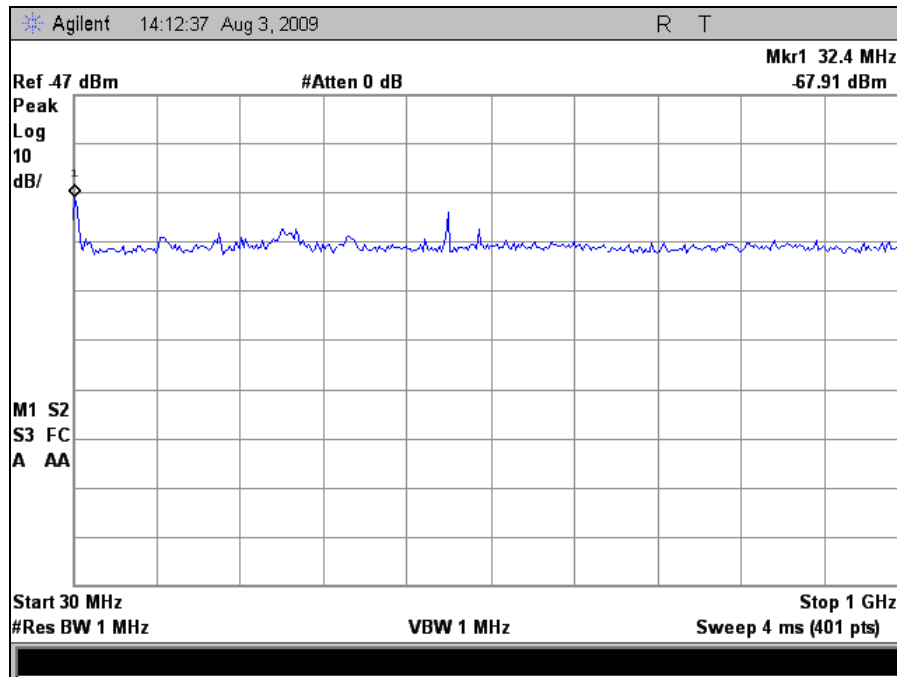

Plot 201. Radiated Spurious, 802.11n 40MHz, 5670 MHz, 30 MHz – 1 GHz, 19 dBi Panel

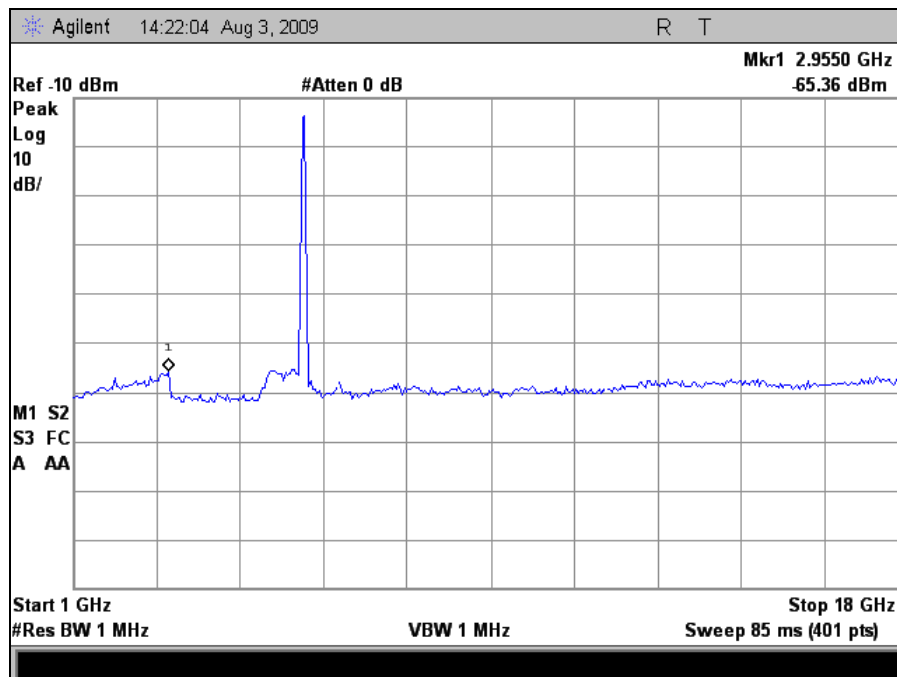

Plot 202. Radiated Spurious, 802.11n 40MHz, 5670 MHz, 1 GHz – 18 GHz, 19 dBi Panel

EIRP

9dBi Omni Antenna								
802.11a	Band Edge Freq	Uncorrected Peak (dBuV)	Cable Loss	ACF	DCF	Corrected	Limit (dBuV/m)	Margin
	5350 MHz	19.89	7.03	35	9.54	52.38	68.23	-15.85
	5470 MHz	24.31	7.03	35	9.54	56.8	68.23	-11.43
	5725 MHz	34.1	7.5	35	9.54	67.06	68.23	-1.17
802.11n 20MHz	Band Edge Freq	Uncorrected Peak (dBuV)	Cable Loss	ACF	DCF	Corrected	Limit (dBuV/m)	Margin
	5350 MHz	19.9	7.03	35	9.54	52.39	68.23	-15.84
	5470 MHz	22.93	7.03	35	9.54	55.42	68.23	-12.81
	5725 MHz	30.75	7.5	35	9.54	63.71	68.23	-4.52
802.11n 40MHz	Band Edge Freq	Uncorrected Peak (dBuV)	Cable Loss	ACF	DCF	Corrected	Limit (dBuV/m)	Margin
	5350 MHz	21	7.03	35	9.54	53.49	68.23	-14.74
	5470 MHz	25.11	7.03	35	9.54	57.6	68.23	-10.63
	5725 MHz	31.66	7.5	35	9.54	64.62	68.23	-3.61

Table 72. EIRP Calculation, 9 dBi Omni

Note: EIRP Limit -27dBm/MHz = 68.23dBuV/m

16dBi Sector Antenna								
802.11a	Band Edge Freq	Uncorrected Peak (dBuV)	Cable Loss	ACF	DCF	Corrected	Limit (dBuV/m)	Margin
	5350 MHz	19.85	7.03	35	9.54	52.34	68.23	-15.89
	5470 MHz	21.42	7.03	35	9.54	53.91	68.23	-14.32
	5725 MHz	33.15	7.5	35	9.54	66.11	68.23	-2.12
802.11n 20MHz	Band Edge Freq	Uncorrected Peak (dBuV)	Cable Loss	ACF	DCF	Corrected	Limit (dBuV/m)	Margin
	5350 MHz	22.34	7.03	35	9.54	54.83	68.23	-13.4
	5470 MHz	22.15	7.03	35	9.54	54.64	68.23	-13.59
	5725 MHz	35.22	7.5	35	9.54	68.18	68.23	-0.05
802.11n 40MHz	Band Edge Freq	Uncorrected Peak (dBuV)	Cable Loss	ACF	DCF	Corrected	Limit (dBuV/m)	Margin
	5350 MHz	21.61	7.03	35	9.54	54.1	68.23	-14.13
	5470 MHz	27.89	7.03	35	9.54	60.38	68.23	-7.85
	5725 MHz	34.12	7.5	35	9.54	67.08	68.23	-1.15

Table 73. EIRP Calculation, 16 dBi Sector

Note: EIRP Limit -27dBm/MHz = 68.23dBuV/m

19dBi Panel Antenna								
	Band Edge Freq	Uncorrected Peak (dBuV)	Cable Loss	ACF	DCF	Corrected	Limit (dBuV/m)	Margin
802.11a	5350 MHz	20.09	7.03	35	9.54	52.58	68.23	-15.65
	5470 MHz	21.92	7.03	35	9.54	54.41	68.23	-13.82
	5725 MHz	33.2	7.5	35	9.54	66.16	68.23	-2.07
802.11n 20MHz	5350 MHz	19.03	7.03	35	9.54	51.52	68.23	-16.71
	5470 MHz	23.2	7.03	35	9.54	55.69	68.23	-12.54
	5725 MHz	34.25	7.5	35	9.54	67.21	68.23	-1.02
802.11n 40MHz	5350 MHz	20.83	7.03	35	9.54	53.32	68.23	-14.91
	5470 MHz	27.54	7.03	35	9.54	60.03	68.23	-8.2
	5725 MHz	34.83	7.5	35	9.54	67.79	68.23	-0.44

Table 74. EIRP Calculation, 19 dBi Panel

Note: EIRP Limit -27dBm/MHz = 68.23dBuV/m

EIRP, Port 1, 802.11a

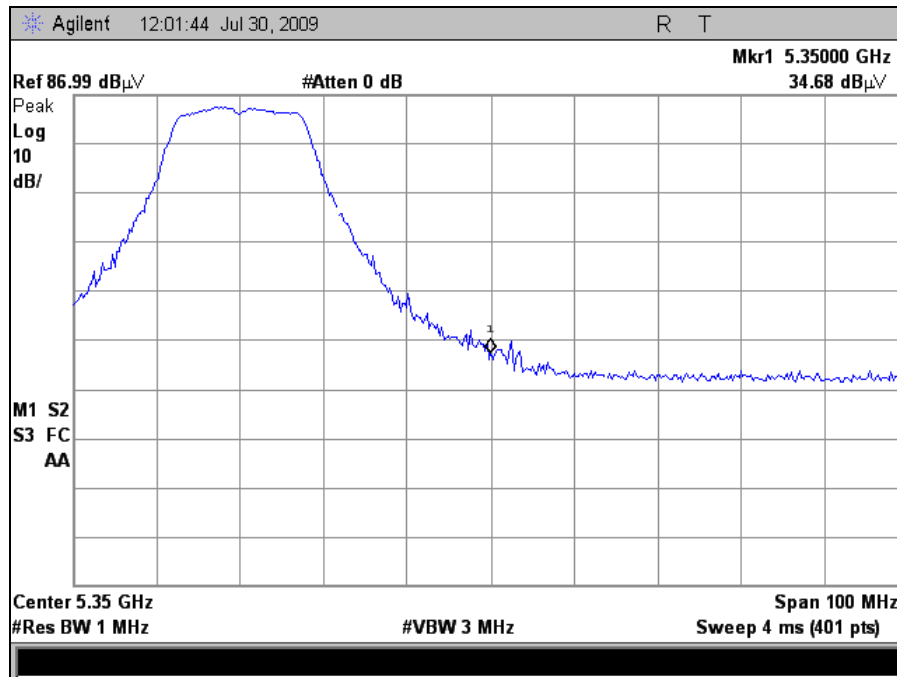

Plot 203. EIRP, Port 1, 802.11a, 5350 MHz Peak, 9 dBi Omni

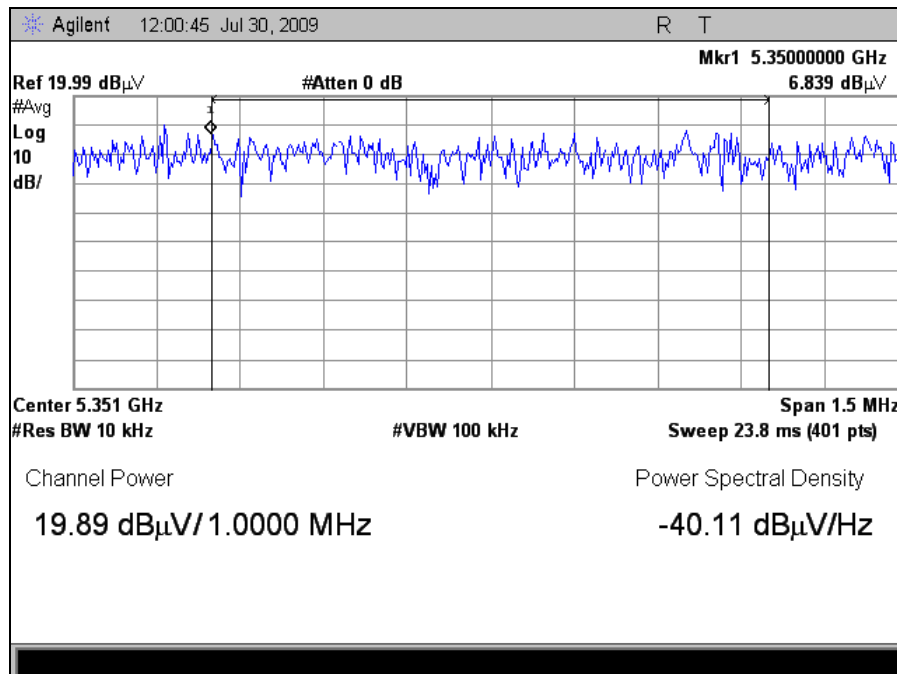

Plot 204. EIRP, Port 1, 802.11a, 5350 MHz Over 1 MHz, 9 dBi Omni

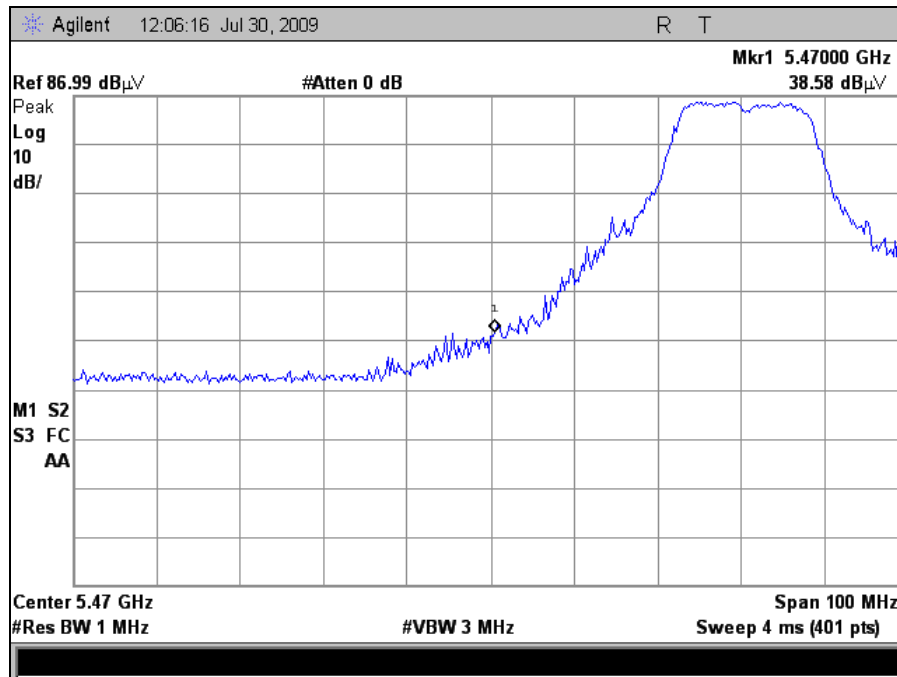

Plot 205. EIRP, Port 1, 802.11a, 5470 MHz Peak, 9 dBi Omni

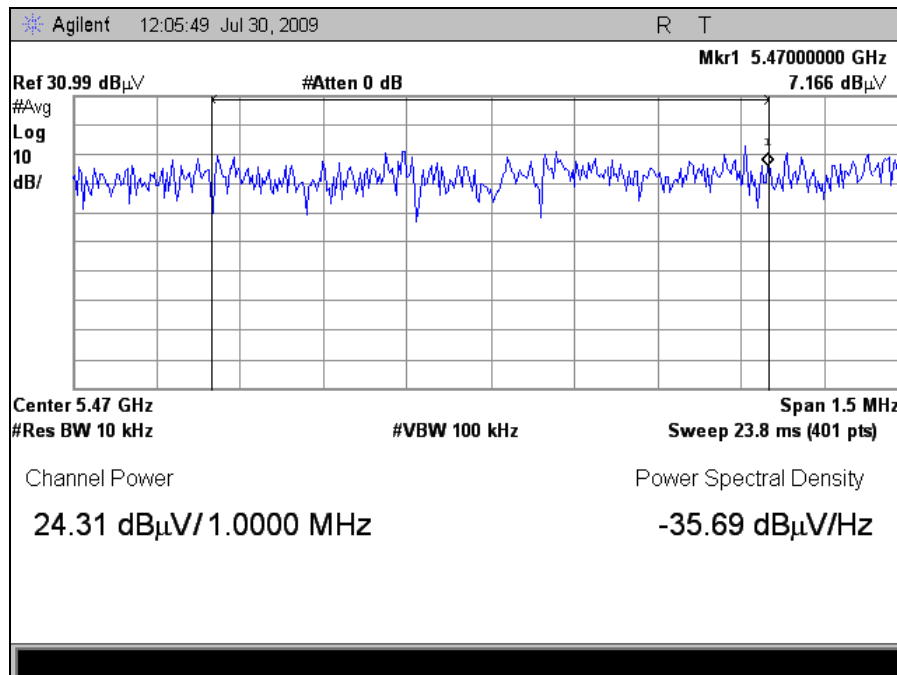

Plot 206. EIRP, Port 1, 802.11a, 5470 MHz Over 1 MHz, 9 dBi Omni

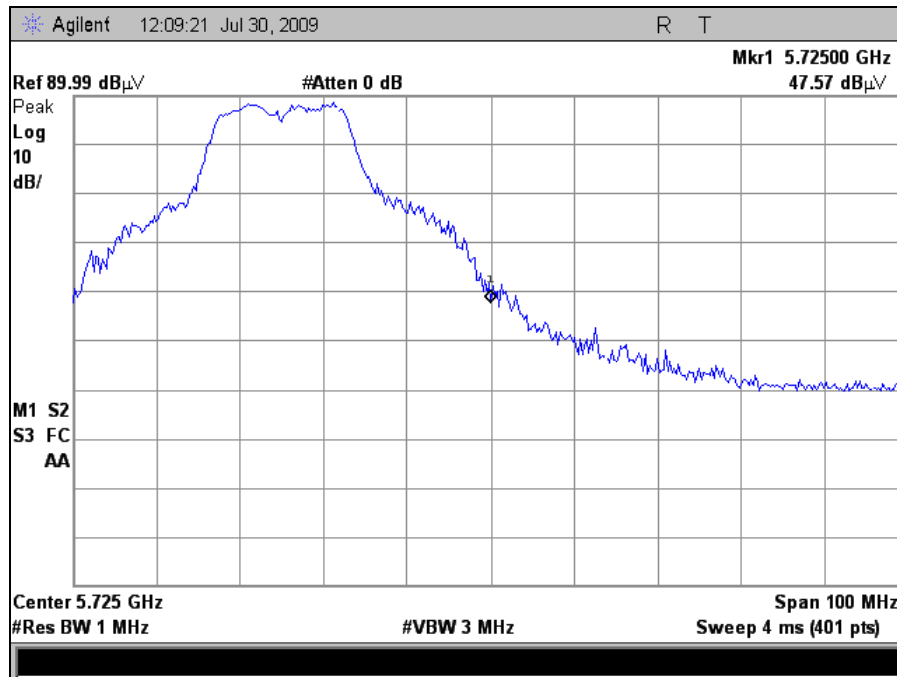

Plot 207. EIRP, Port 1, 802.11a, 5725 MHz Peak, 9 dBi Omni

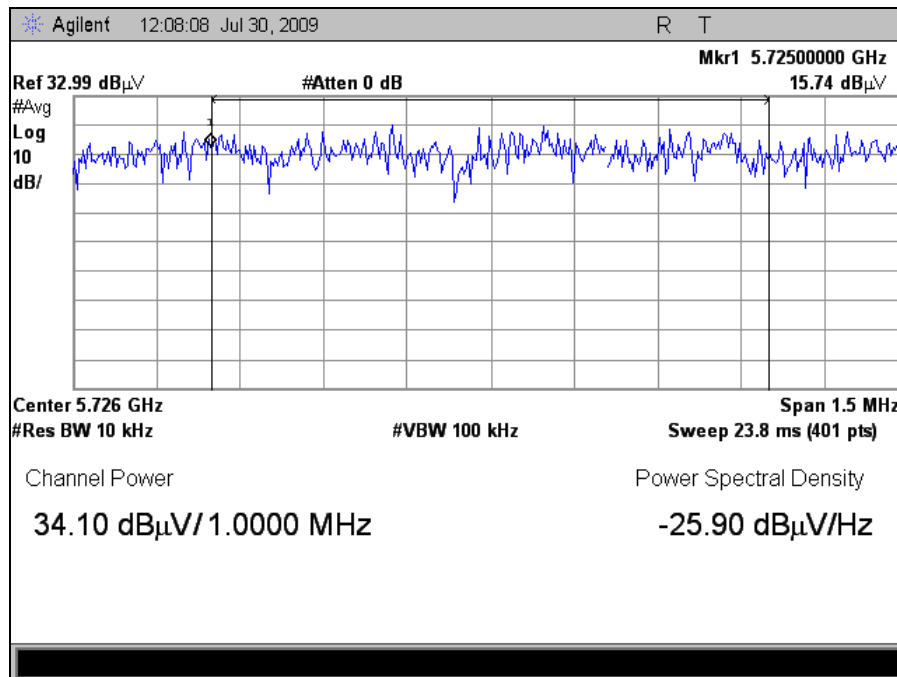

Plot 208. EIRP, Port 1, 802.11a, 5725 MHz Over 1 MHz, 9 dBi Omni

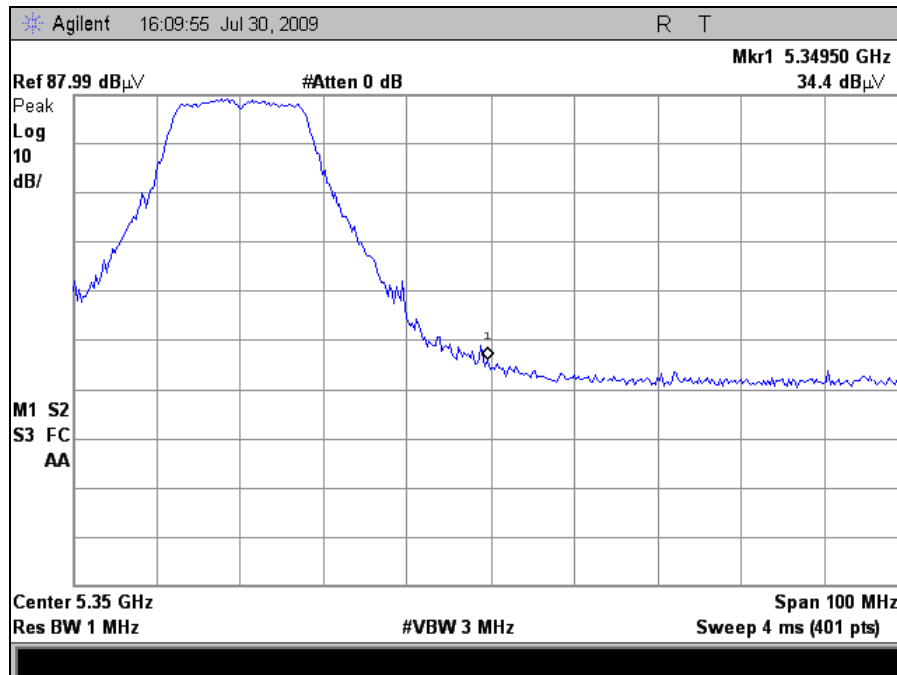

Plot 209. EIRP, Port 1, 802.11a, 5350 MHz Peak, 16 dBi Sector

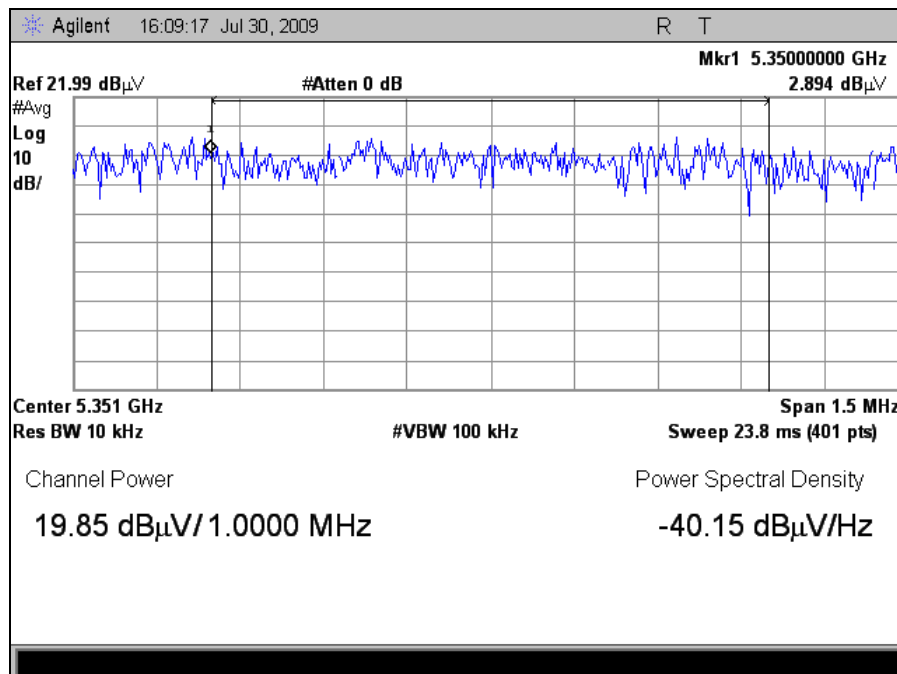

Plot 210. EIRP, Port 1, 802.11a, 5350 MHz Over 1 MHz, 16 dBi Sector

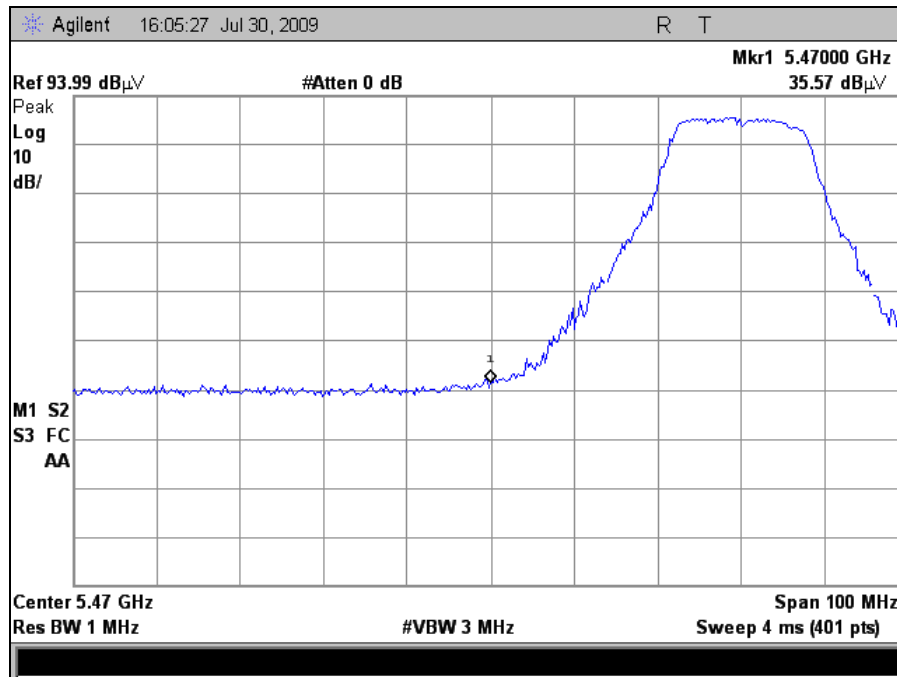

Plot 211. EIRP, Port 1, 802.11a, 5470 MHz Peak, 16 dBi Sector

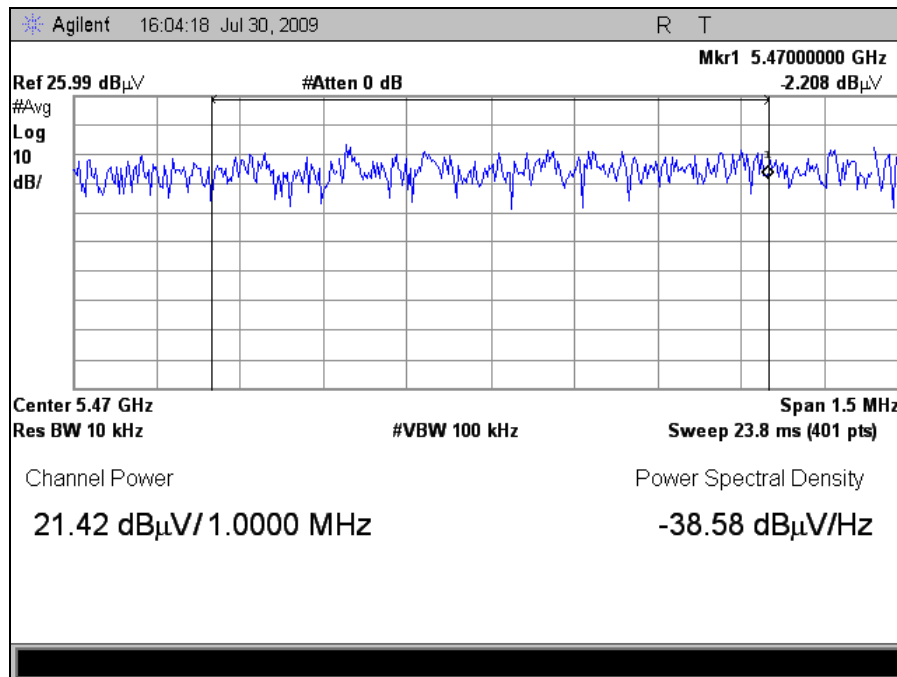

Plot 212. EIRP, Port 1, 802.11a, 5470 MHz Over 1 MHz, 16 dBi Sector

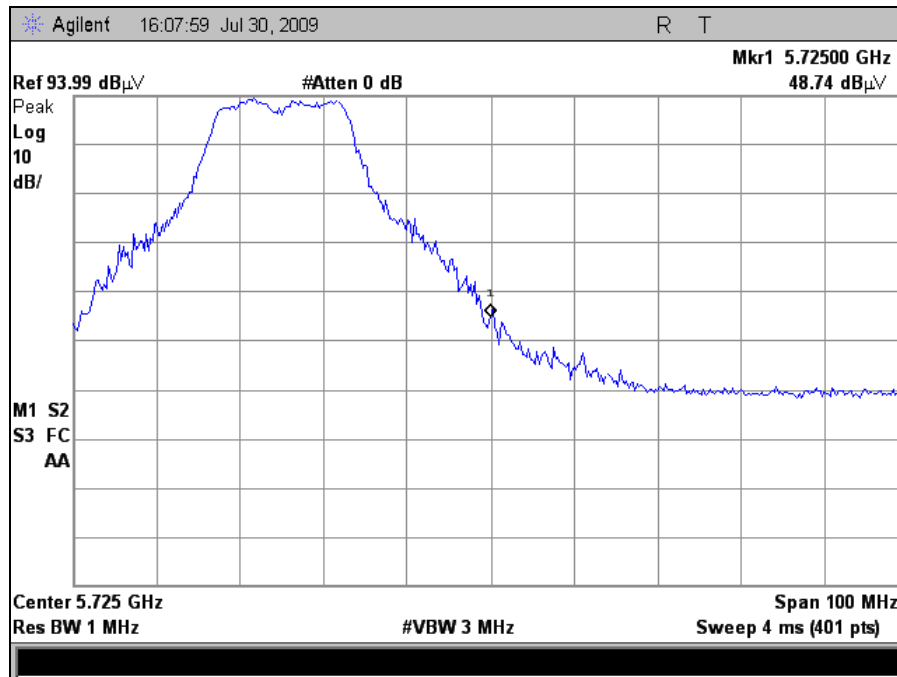

Plot 213. EIRP, Port 1, 802.11a, 5725 MHz Peak, 16 dBi Sector

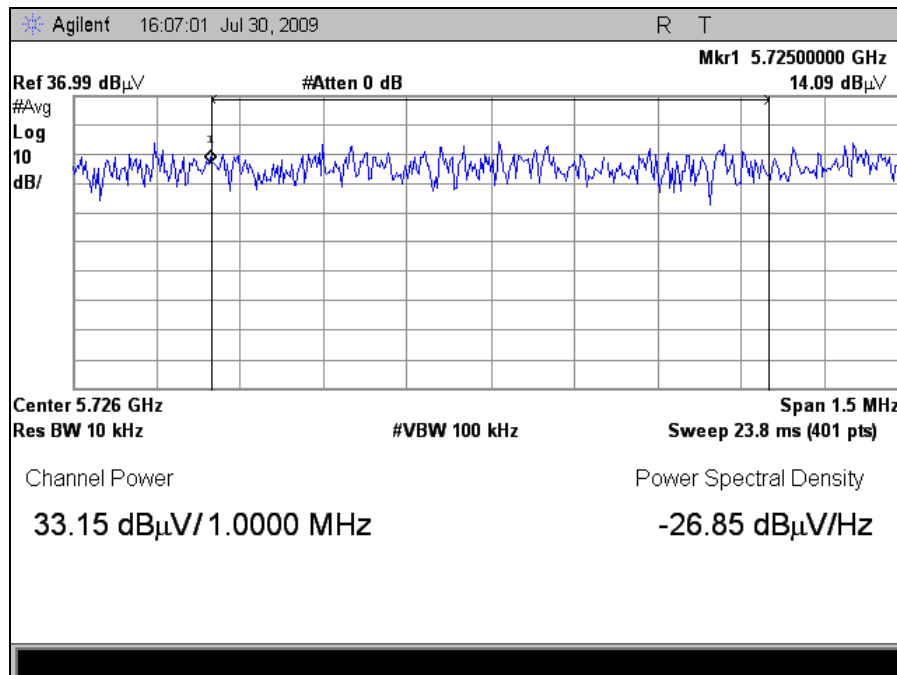

Plot 214. EIRP, Port 1, 802.11a, 5725 MHz Over 1 MHz, 16 dBi Sector

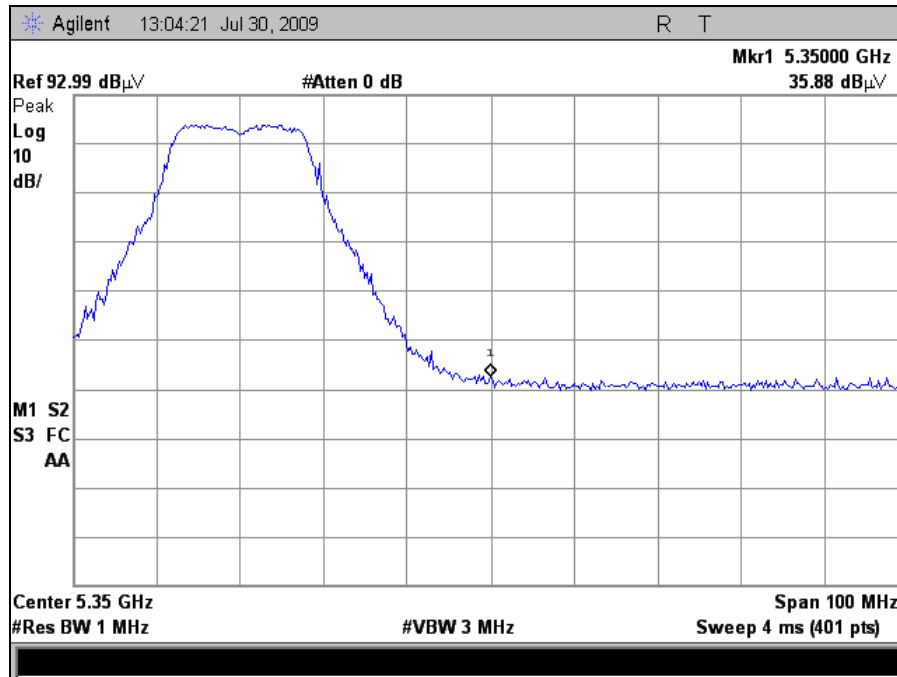

Plot 215. EIRP, Port 1, 802.11a, 5350 MHz Peak, 19 dBi Panel

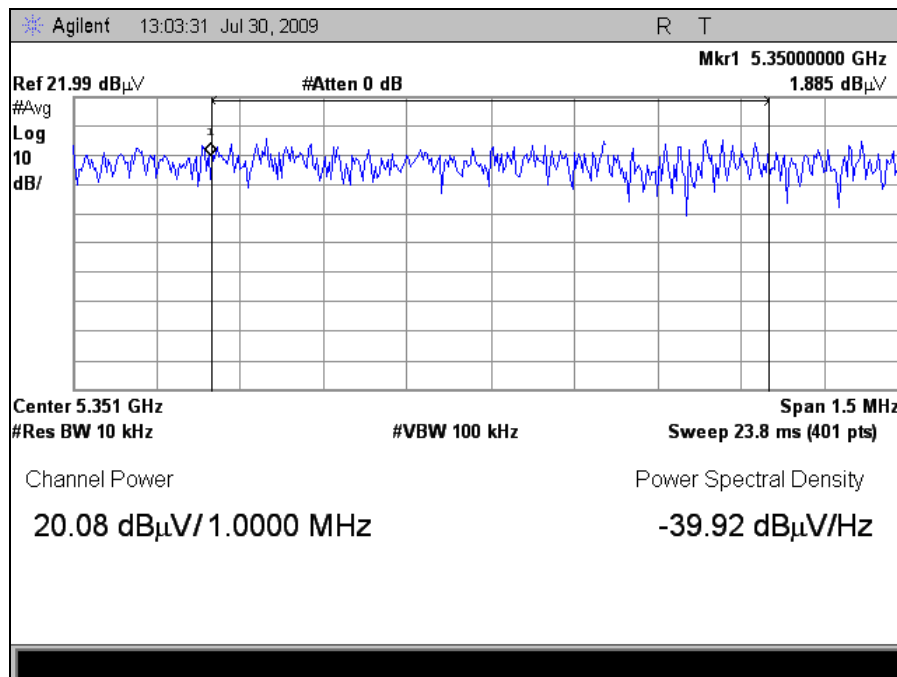

Plot 216. EIRP, Port 1, 802.11a, 5350 MHz Over 1 MHz, 19 dBi Panel

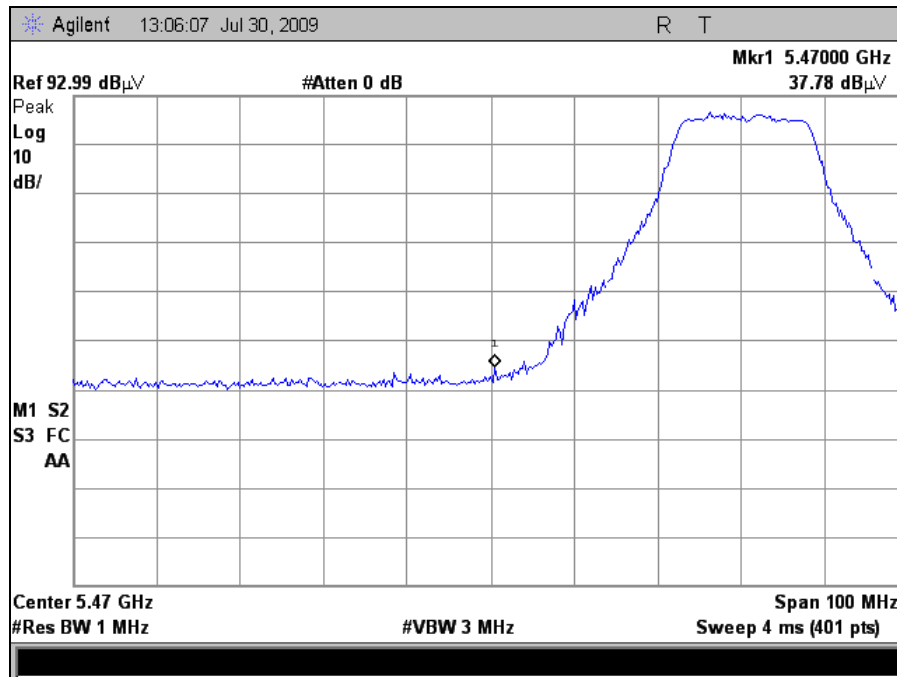

Plot 217. EIRP, Port 1, 802.11a, 5470 MHz Peak, 19 dBi Panel

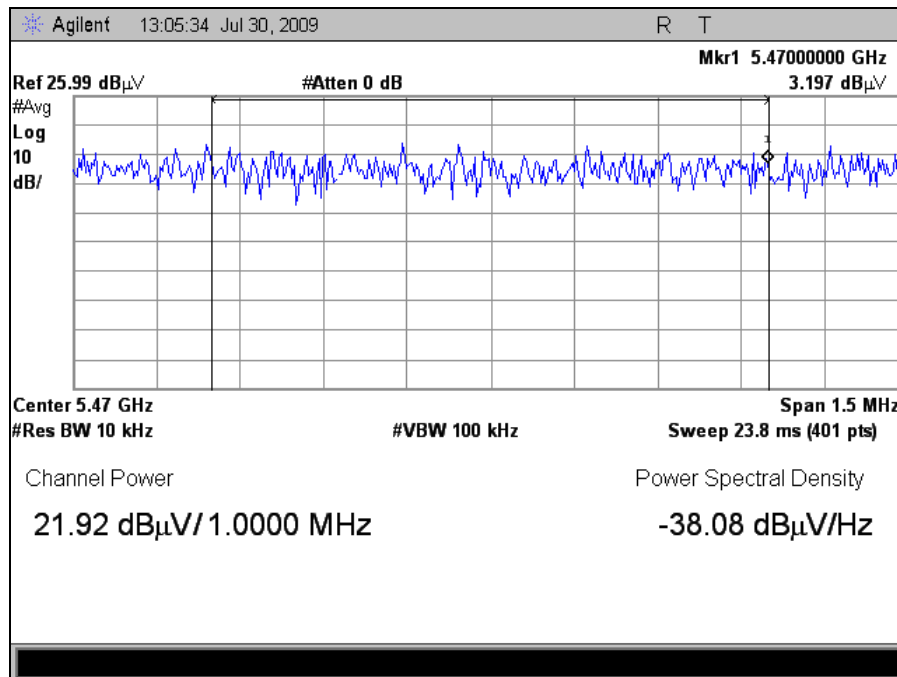

Plot 218. EIRP, Port 1, 802.11a, 5470 MHz Over 1 MHz, 19 dBi Panel

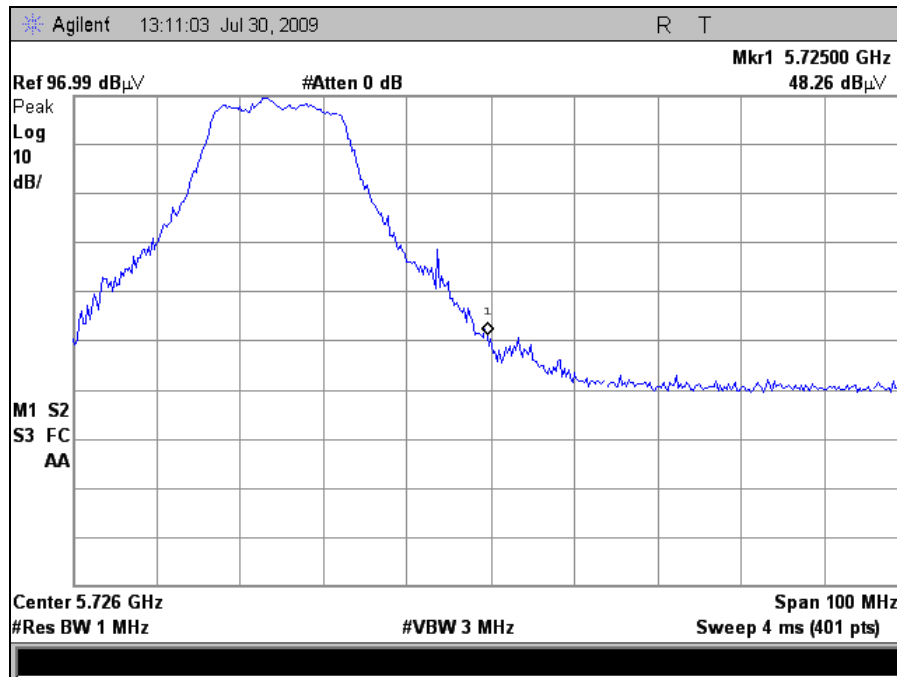

Plot 219. EIRP, Port 1, 802.11a, 5725 MHz Peak, 19 dBi Panel

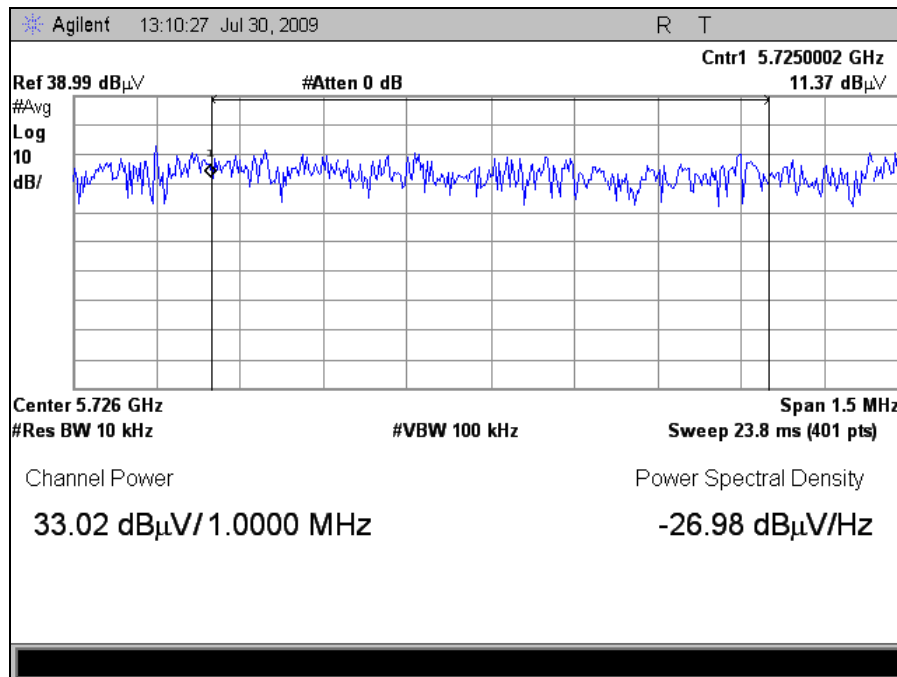

Plot 220. EIRP, Port 1, 802.11a, 5725 MHz Over 1 MHz, 19 dBi Panel

EIRP, 802.11n 20MHz

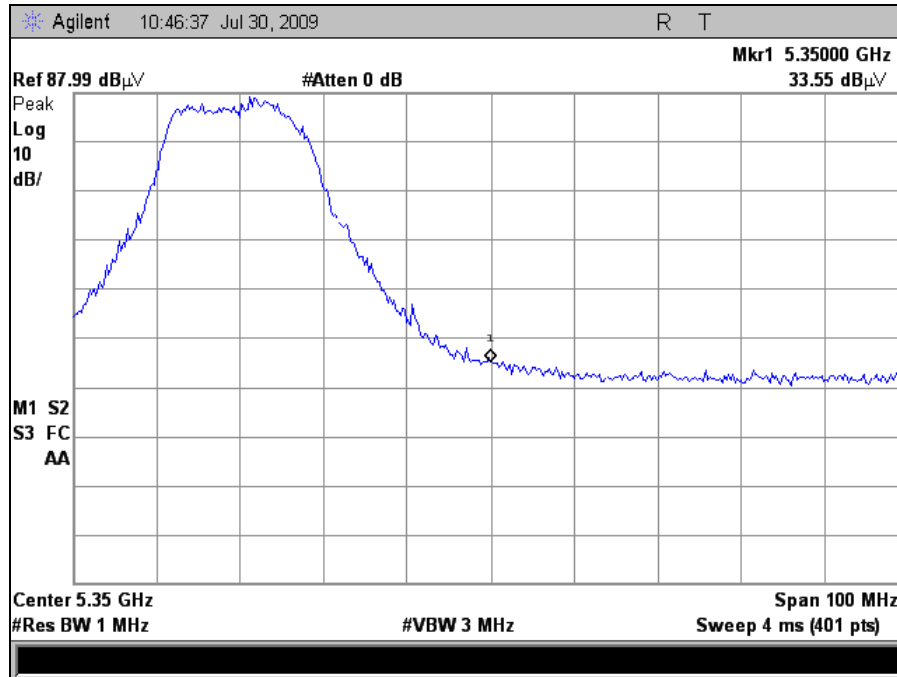

Plot 221. EIRP, 802.11n 20MHz, 5350 MHz Peak, 9 dBi Omni

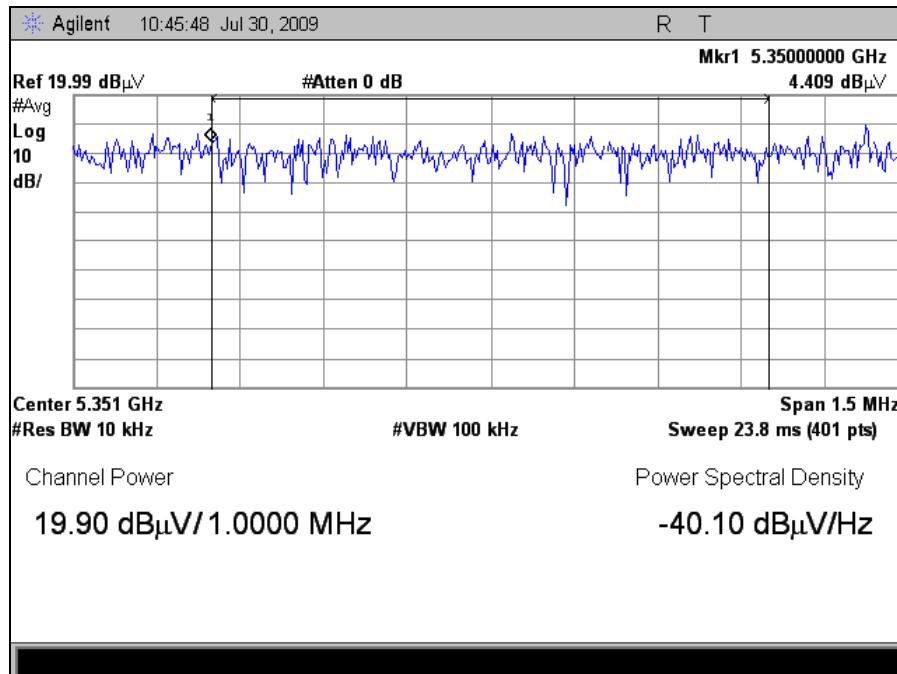

Plot 222. EIRP, 802.11n 20MHz, 5350 MHz Over 1 MHz, 9 dBi Omni

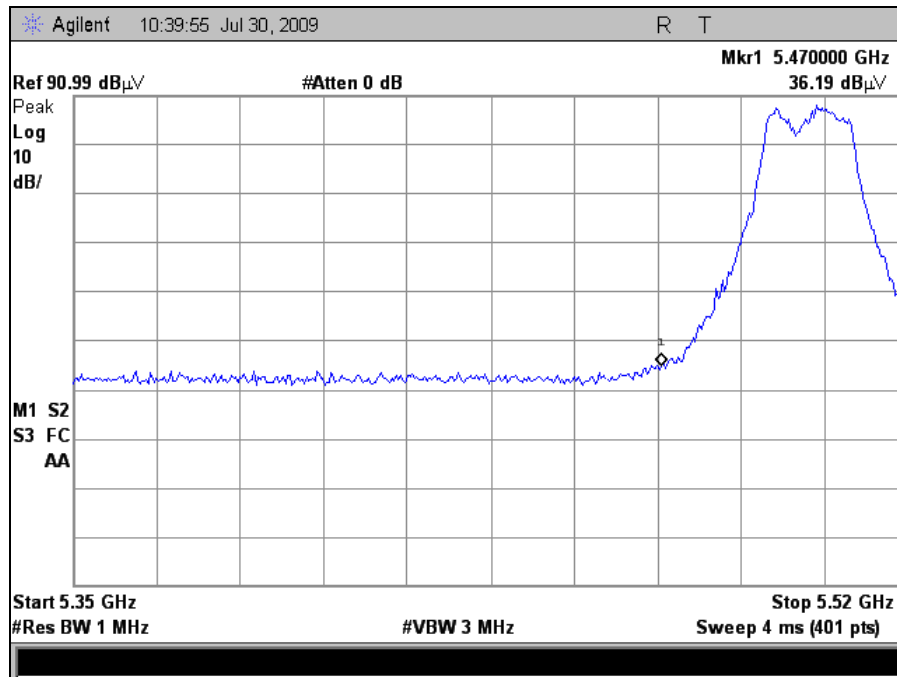

Plot 223. EIRP, 802.11n 20MHz, 5470 MHz Peak, 9 dBi Omni

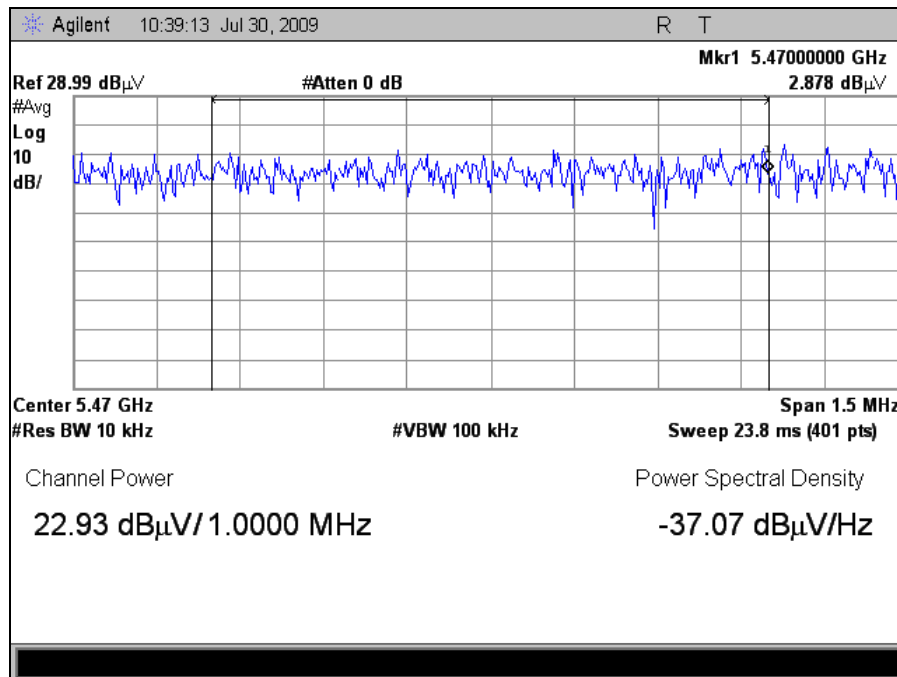

Plot 224. EIRP, 802.11n 20MHz, 5470 MHz Over 1 MHz, 9 dBi Omni

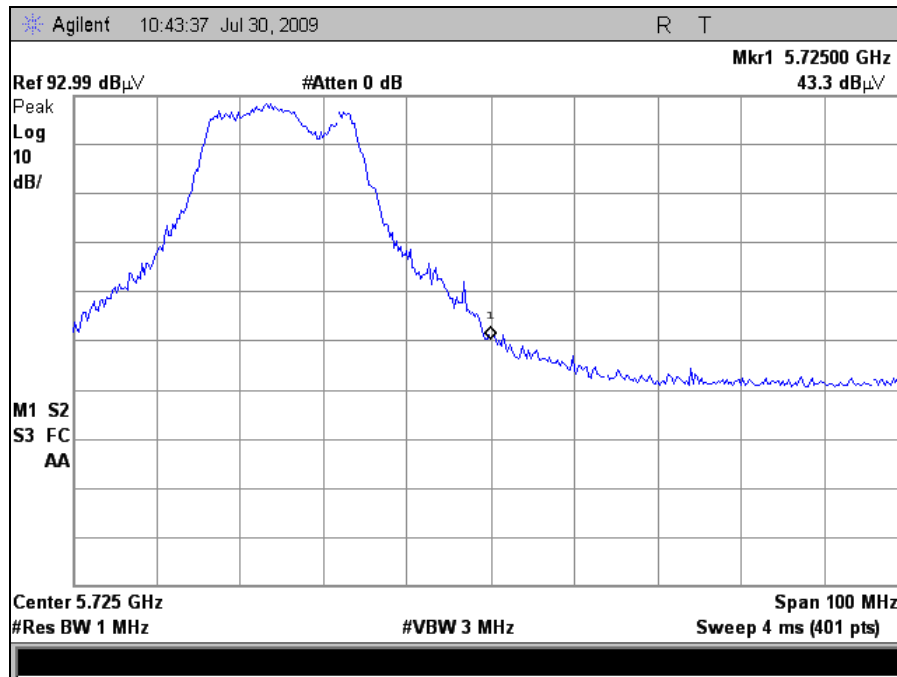

Plot 225. EIRP, 802.11n 20MHz, 5725 MHz Peak, 9 dBi Omni

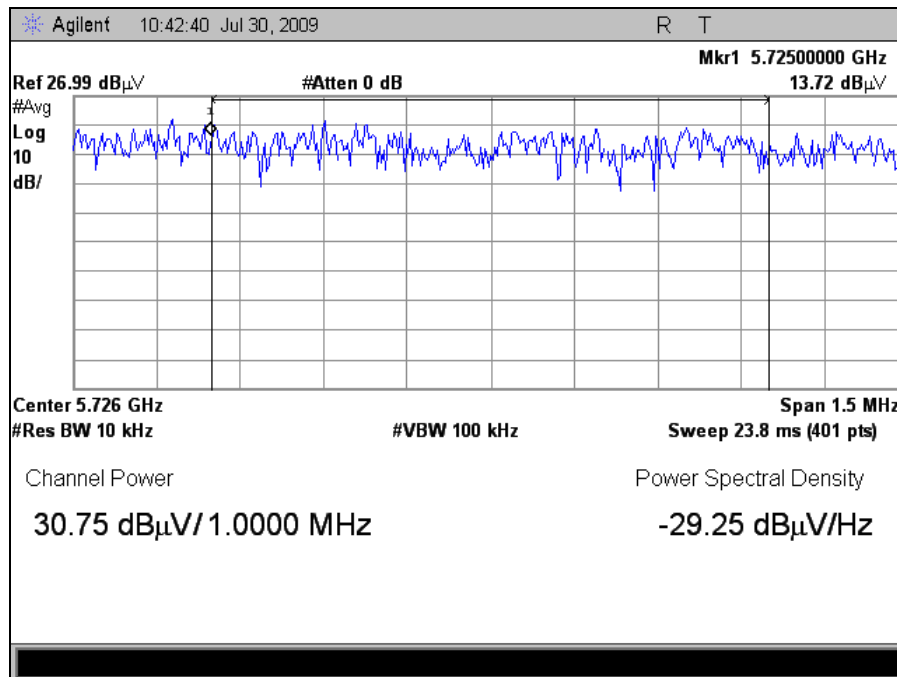

Plot 226. EIRP, 802.11n 20MHz, 5725 MHz Over 1 MHz, 9 dBi Omni

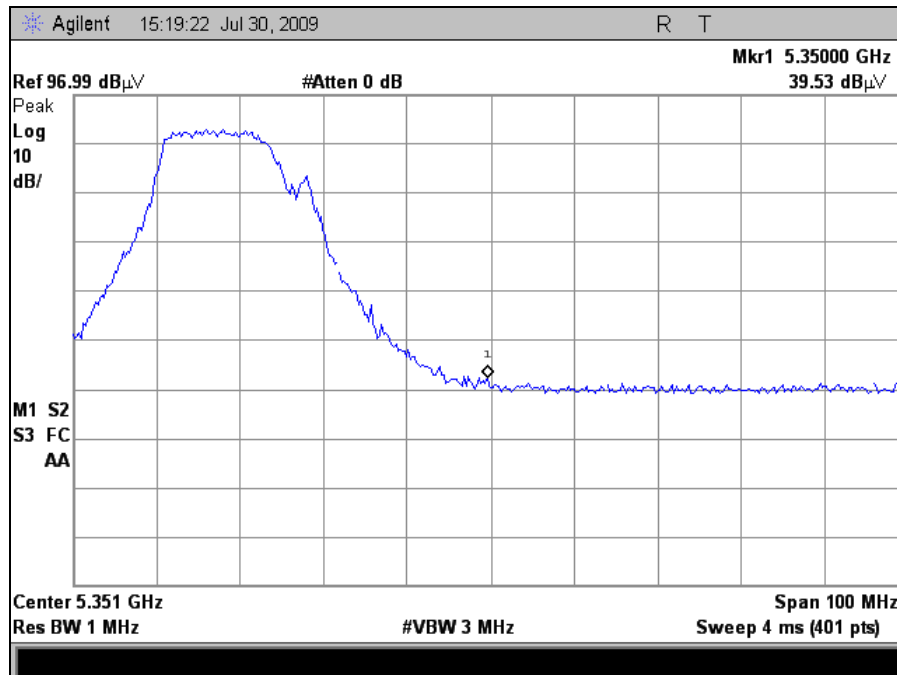

Plot 227. EIRP, 802.11n 20MHz, 5350 MHz Peak, 16 dBi Sector

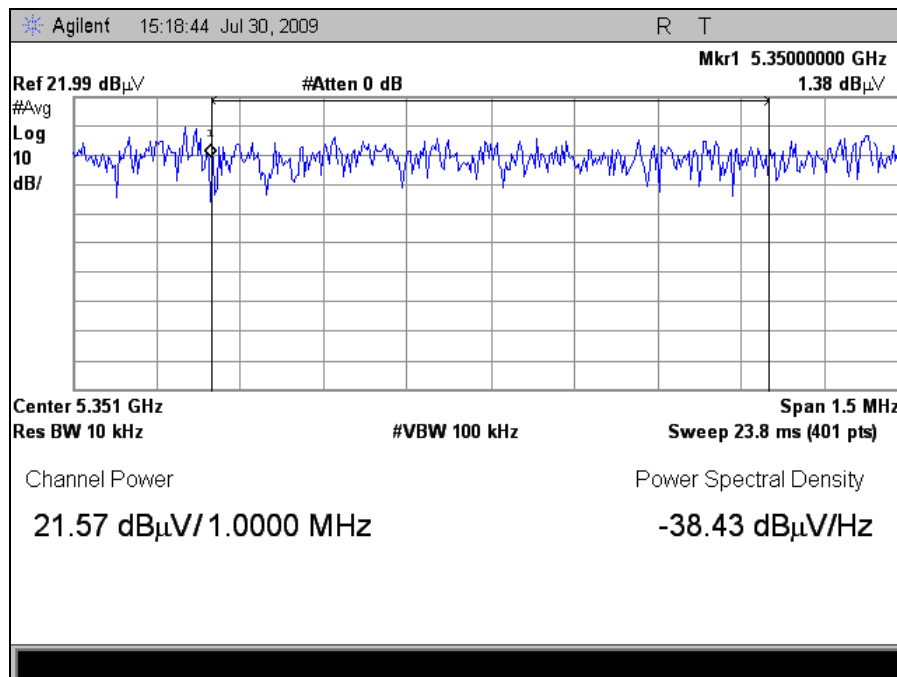

Plot 228. EIRP, 802.11n 20MHz, 5350 MHz Over 1 MHz, 16 dBi Sector

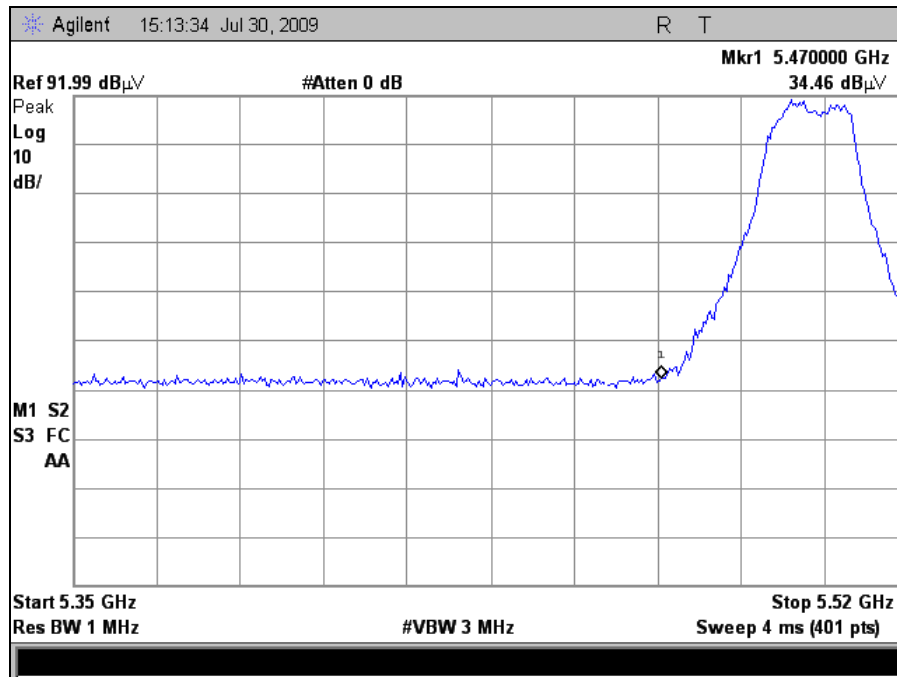

Plot 229. EIRP, 802.11n 20MHz, 5470 MHz Peak, 16 dBi Sector

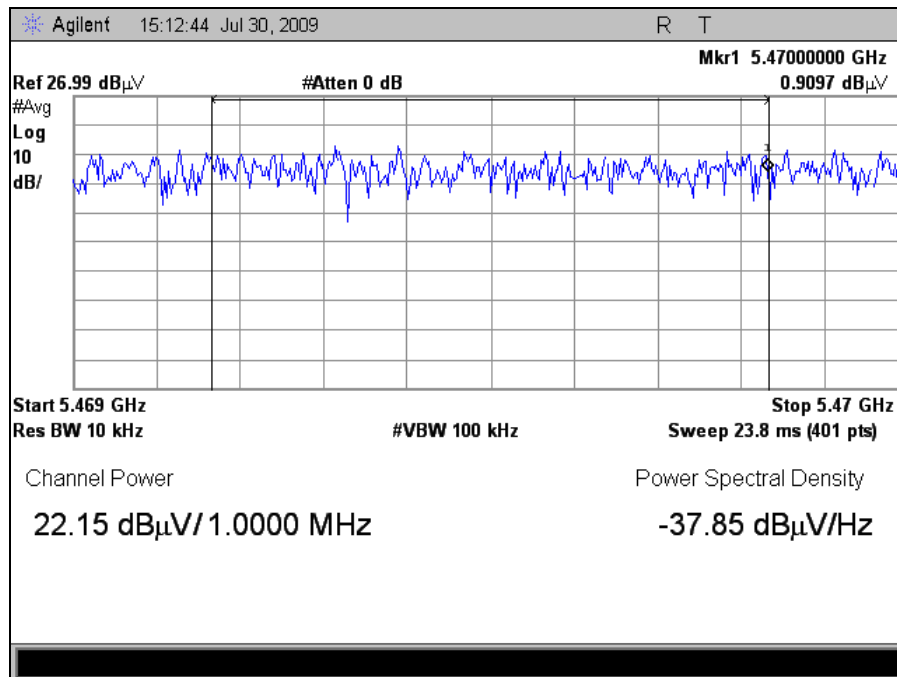

Plot 230. EIRP, 802.11n 20MHz, 5470 MHz Over 1 MHz, 16 dBi Sector

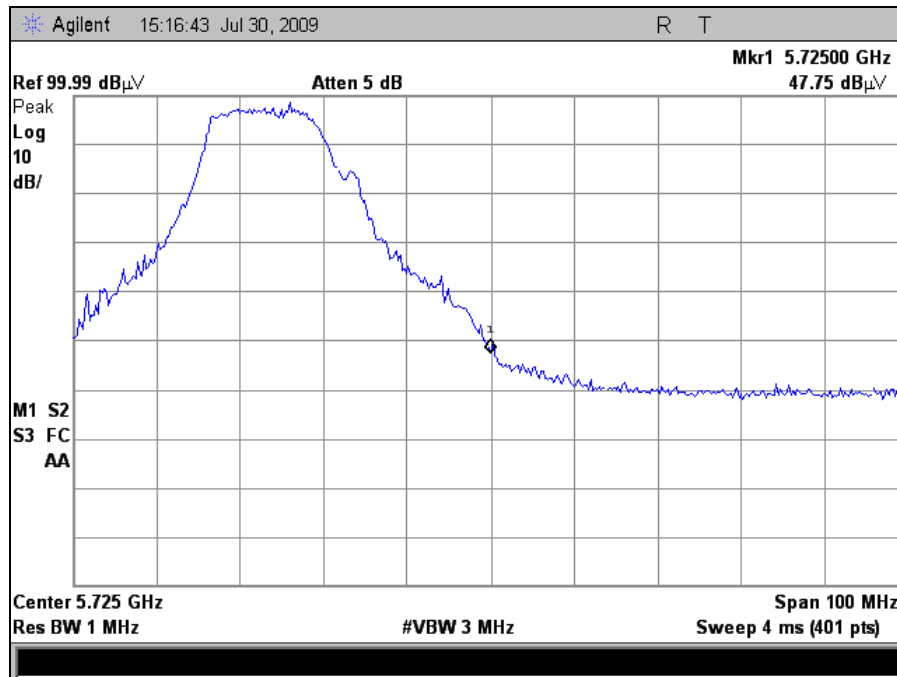

Plot 231. EIRP, 802.11n 20MHz, 5725 MHz Peak, 16 dBi Sector

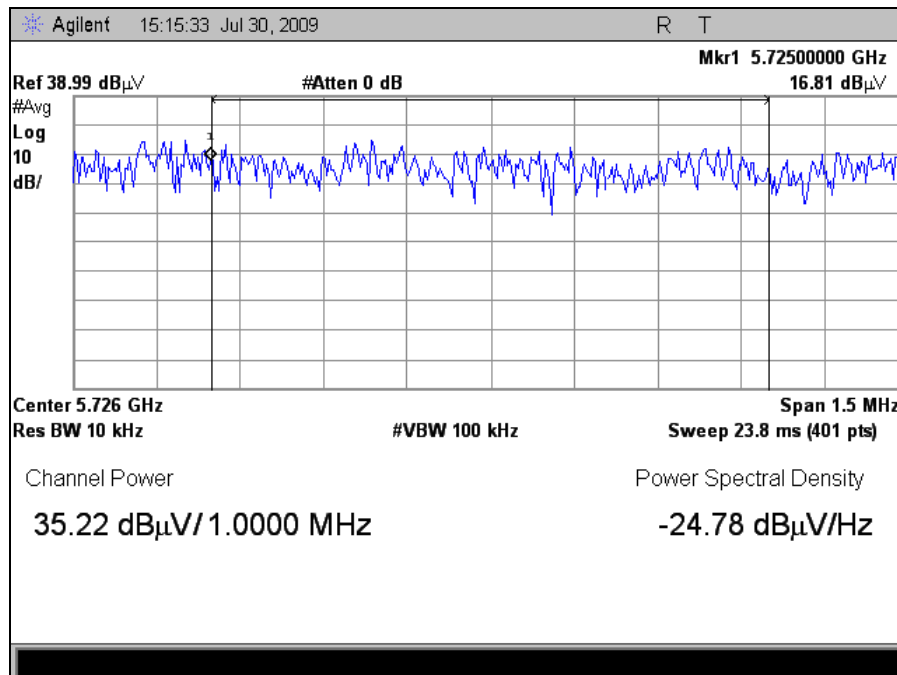

Plot 232. EIRP, 802.11n 20MHz, 5725 MHz Over 1 MHz, 16 dBi Sector

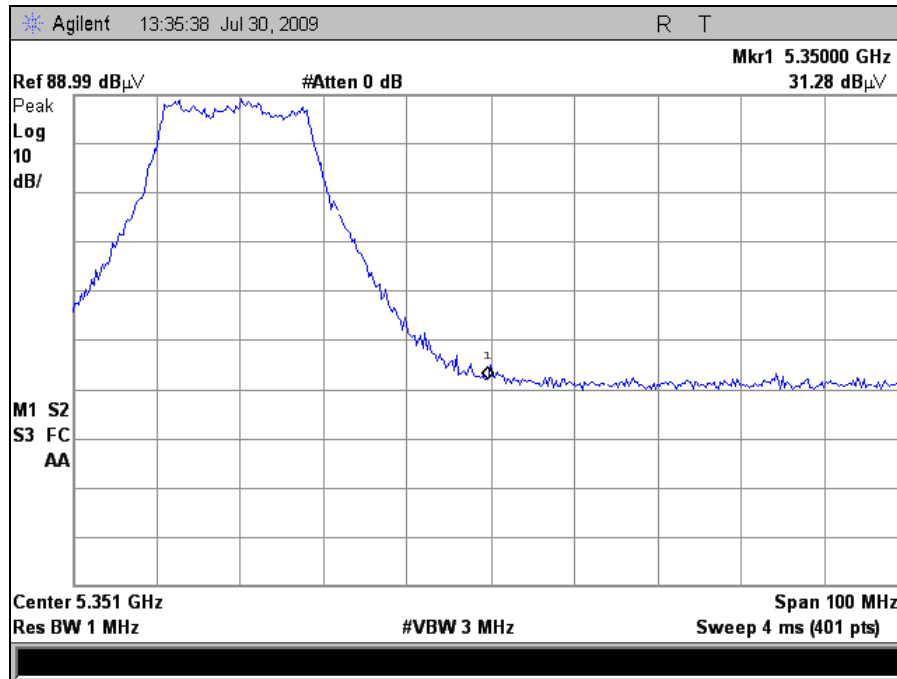

Plot 233. EIRP, 802.11n 20MHz, 5350 MHz Peak, 19 dBi Panel

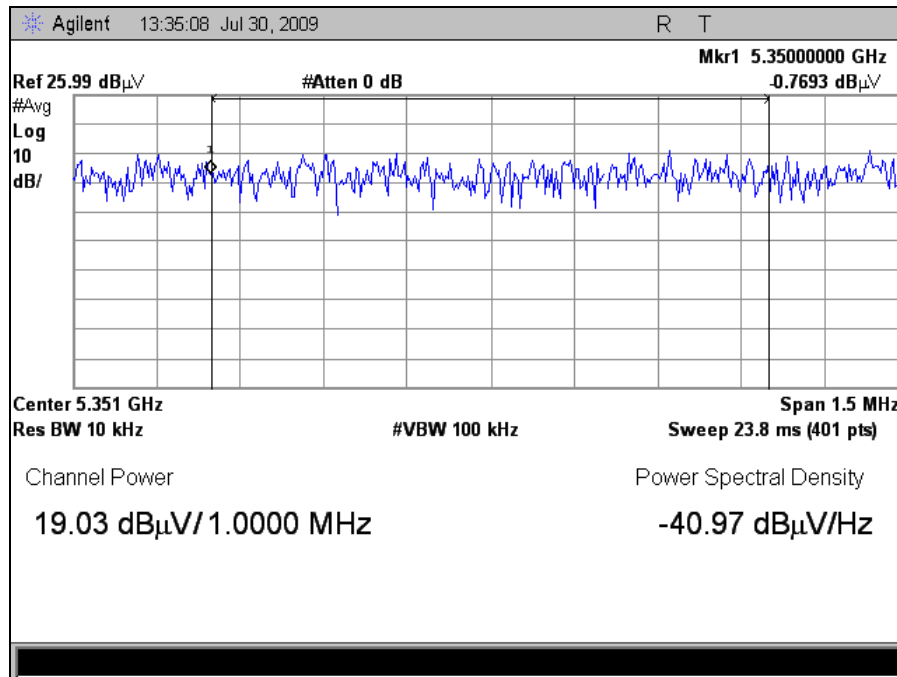

Plot 234. EIRP, 802.11n 20MHz, 5350 MHz Over 1 MHz, 19 dBi Panel

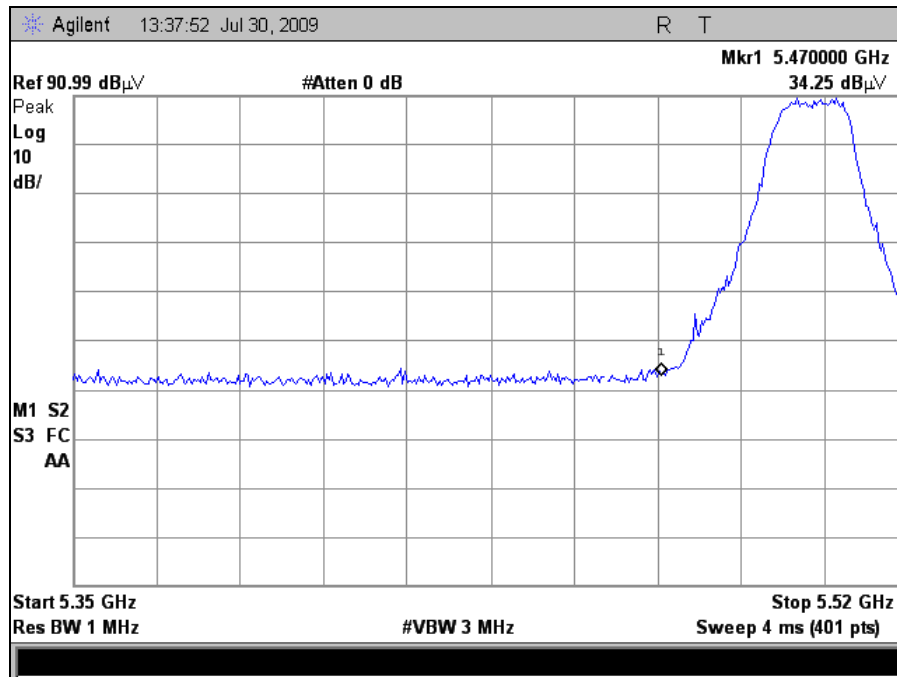

Plot 235. EIRP, 802.11n 20MHz, 5470 MHz Peak, 19 dBi Panel

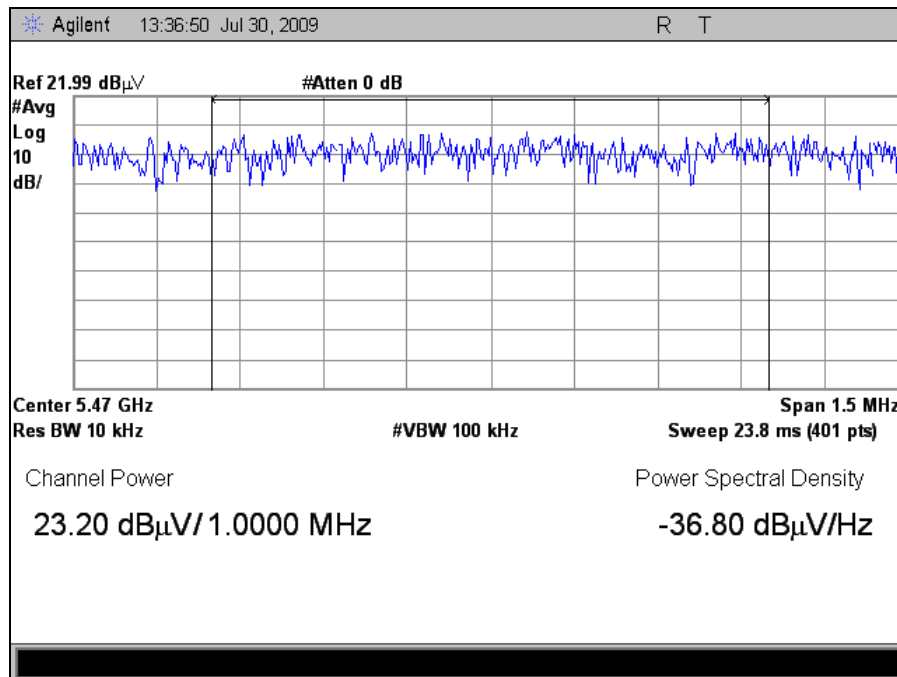

Plot 236. EIRP, 802.11n 20MHz, 5470 MHz Over 1 MHz, 19 dBi Panel

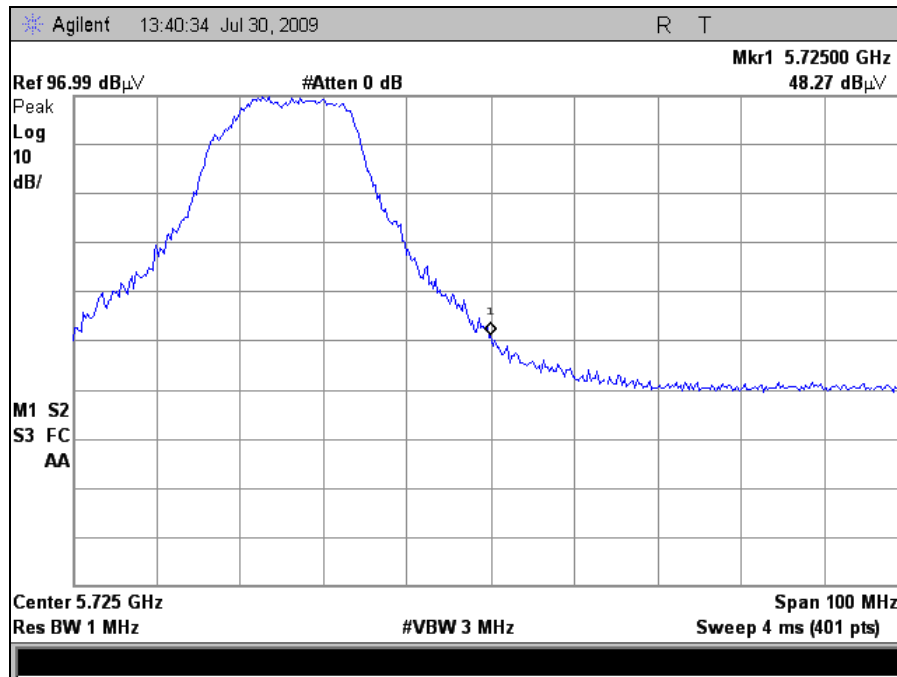

Plot 237. EIRP, 802.11n 20MHz, 5725 MHz Peak, 19 dBi Panel

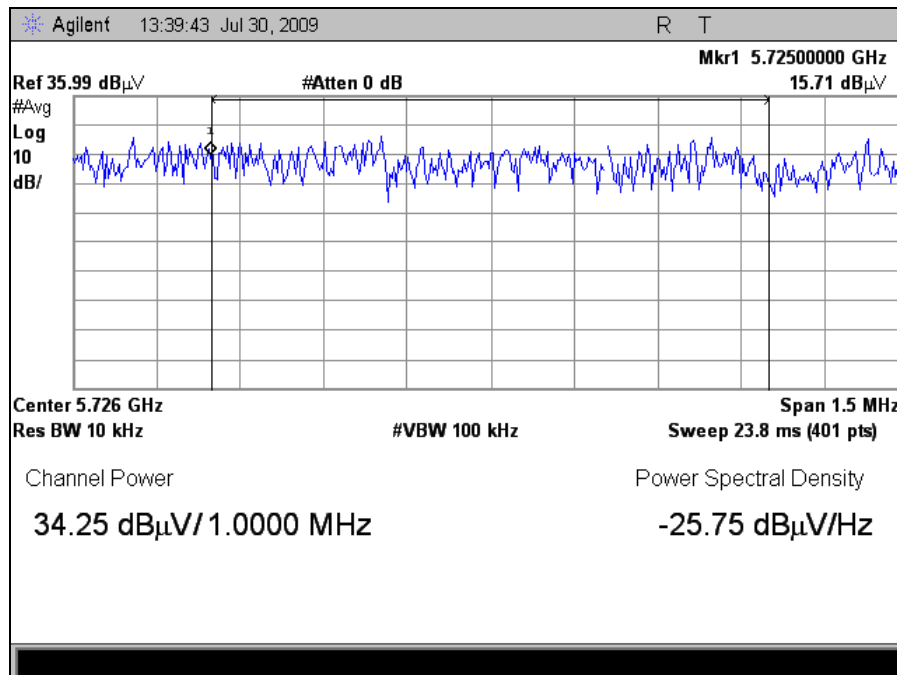

Plot 238. EIRP, 802.11n 20MHz, 5725 MHz Over 1 MHz, 19 dBi Panel

EIRP, 802.11n 40MHz

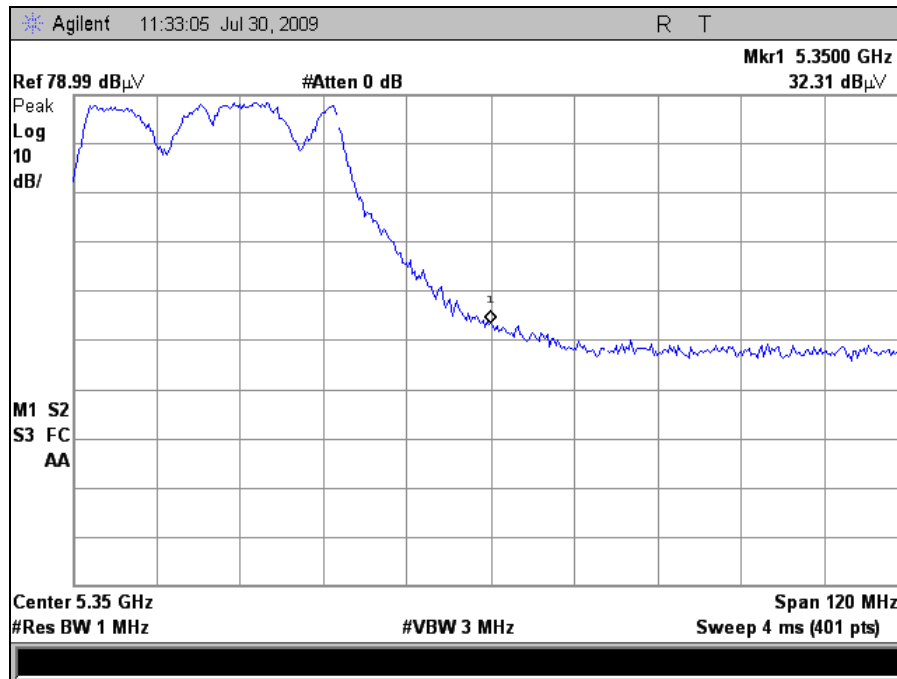

Plot 239. EIRP, 802.11n 40MHz, 5350 MHz Peak, 9 dBi Omni

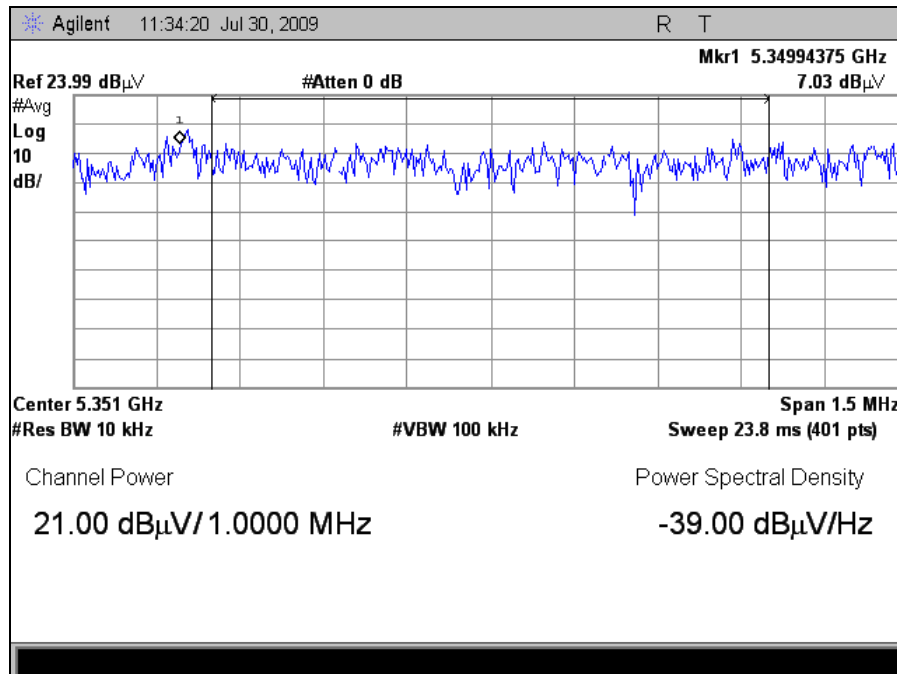

Plot 240. EIRP, 802.11n 40MHz, 5350 MHz Over 1 MHz, 9 dBi Omni

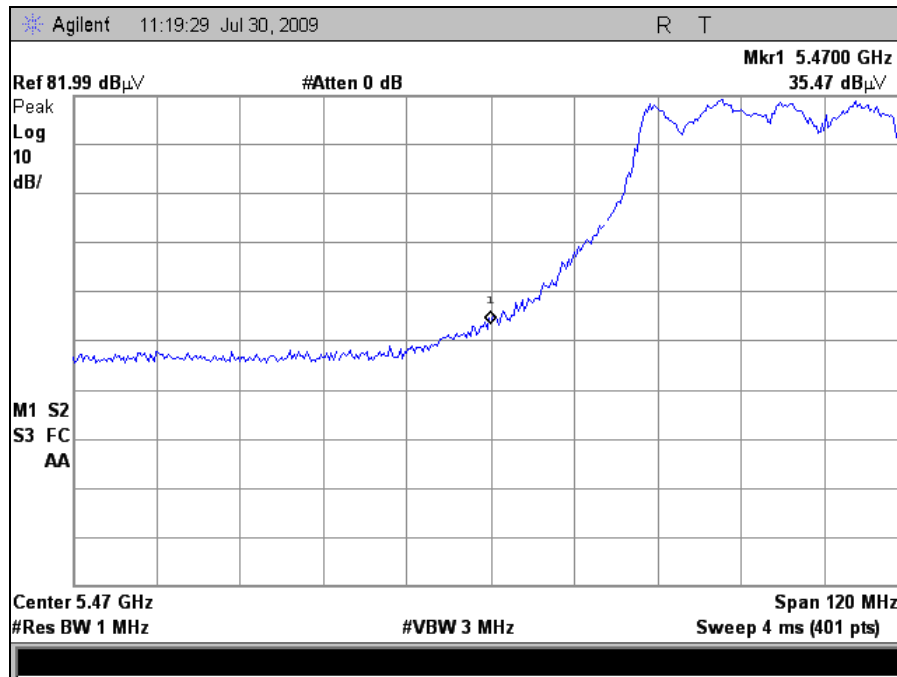

Plot 241. EIRP, 802.11n 40MHz, 5470 MHz Peak, 9 dBi Omni

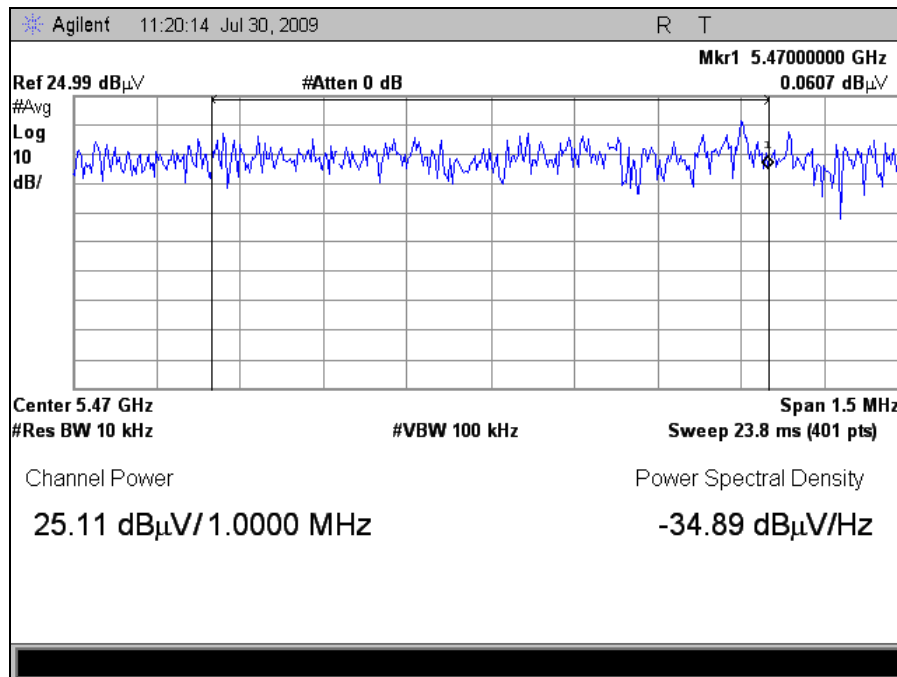

Plot 242. EIRP, 802.11n 40MHz, 5470 MHz Over 1 MHz, 9 dBi Omni

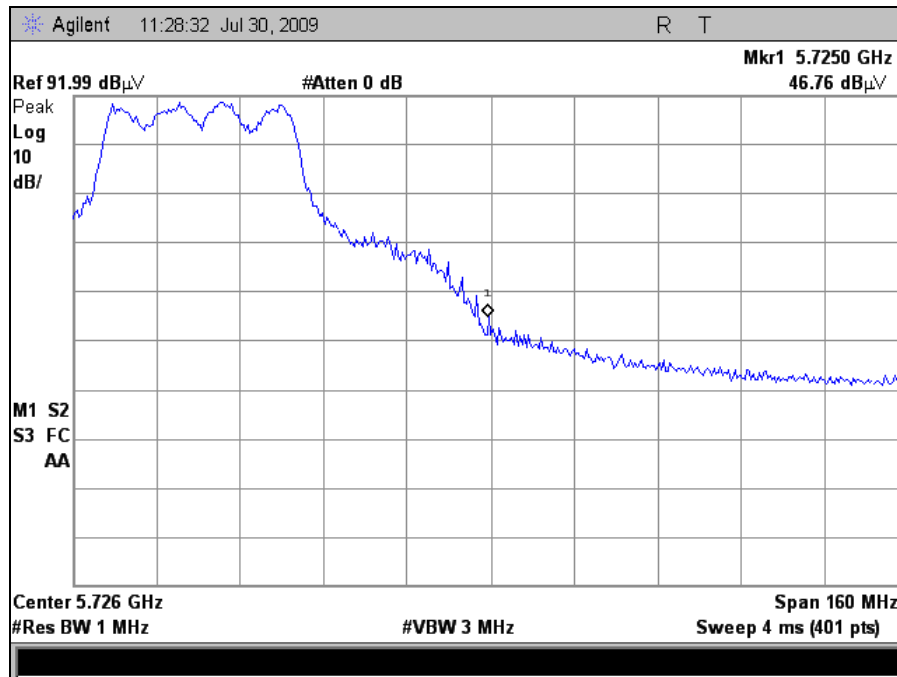

Plot 243. EIRP, 802.11n 40MHz, 5725 MHz Peak, 9 dBi Omni

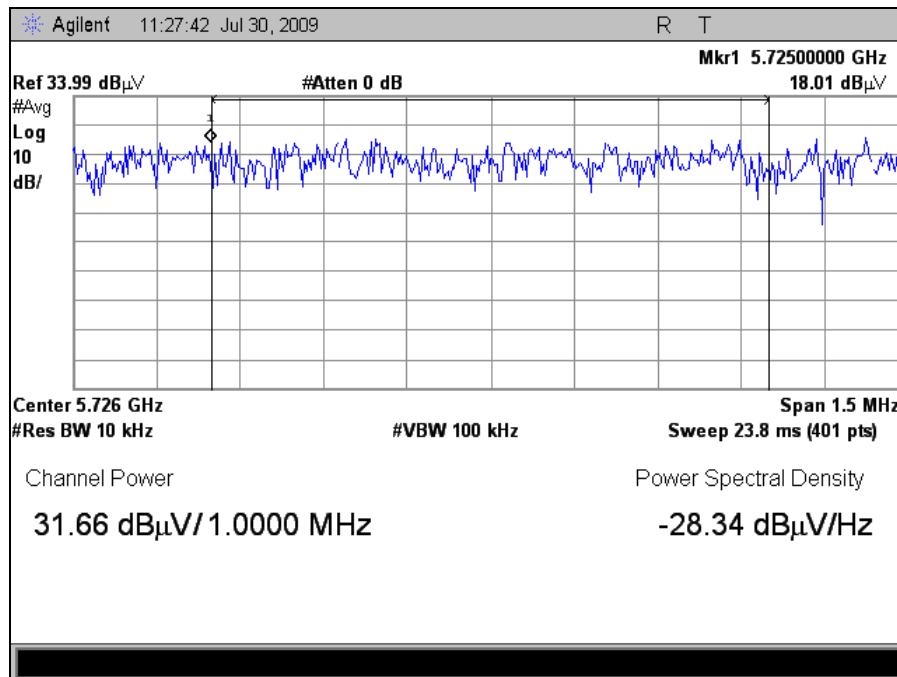

Plot 244. EIRP, 802.11n 40MHz, 5725 MHz Over 1 MHz, 9 dBi Omni

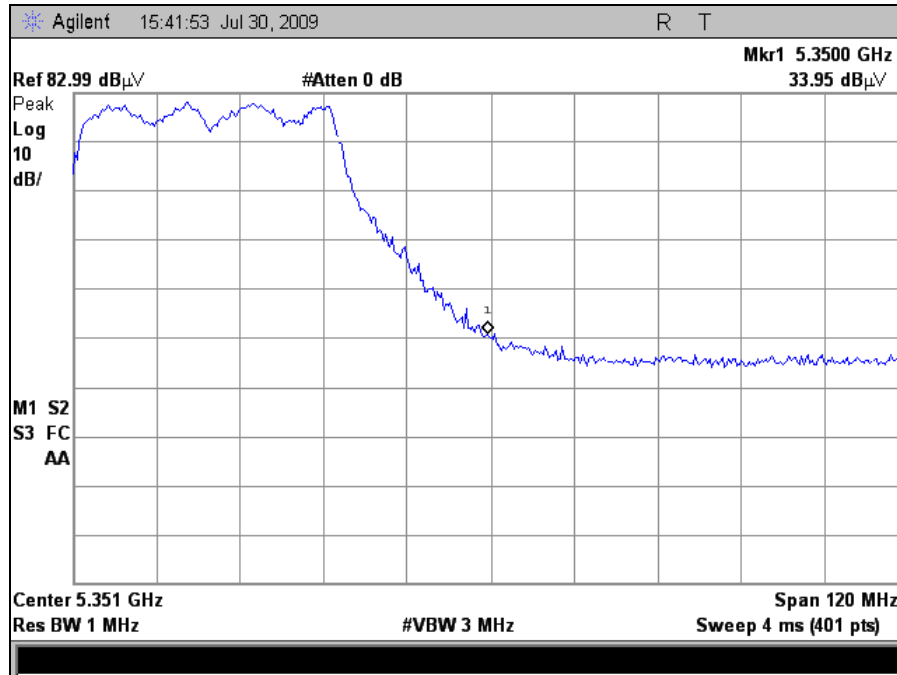

Plot 245. EIRP, 802.11n 40MHz, 5350 MHz Peak, 16 dBi Sector

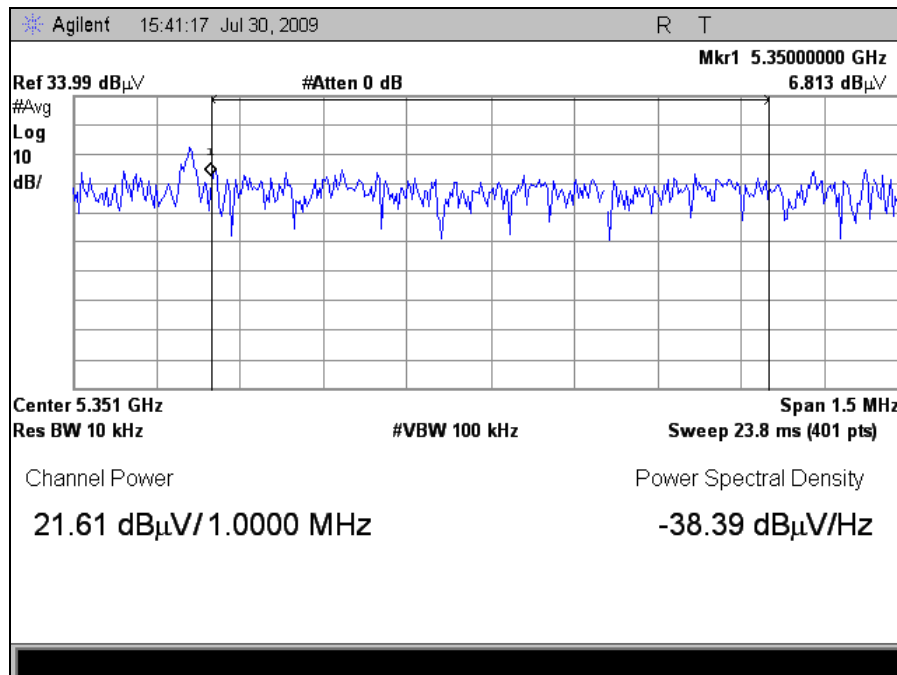

Plot 246. EIRP, 802.11n 40MHz, 5350 MHz Over 1 MHz, 16 dBi Sector

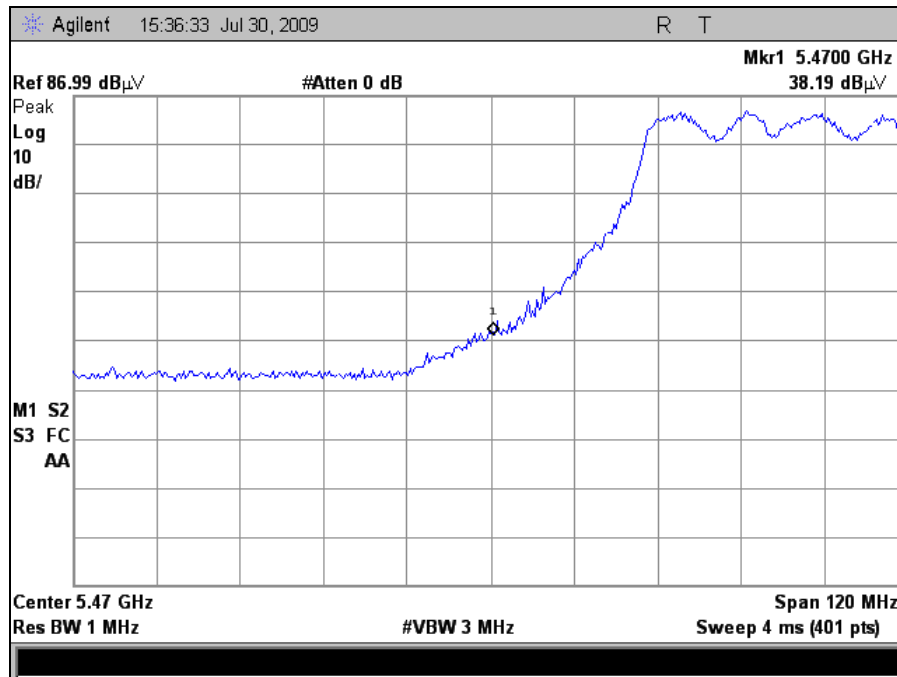

Plot 247. EIRP, 802.11n 40MHz, 5470 MHz Peak, 16 dBi Sector

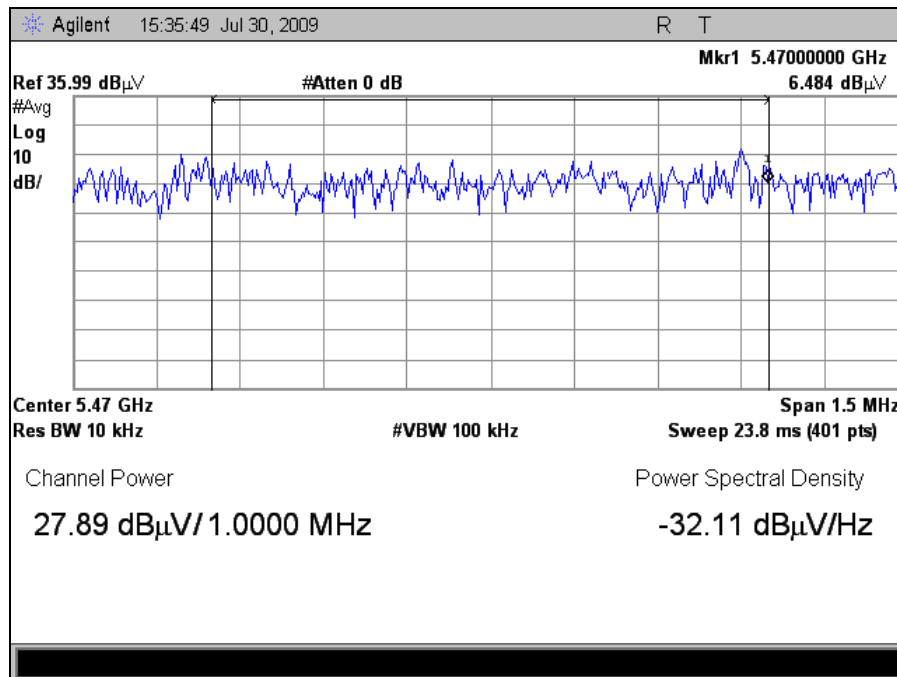

Plot 248. EIRP, 802.11n 40MHz, 5470 MHz Over 1 MHz, 16 dBi Sector

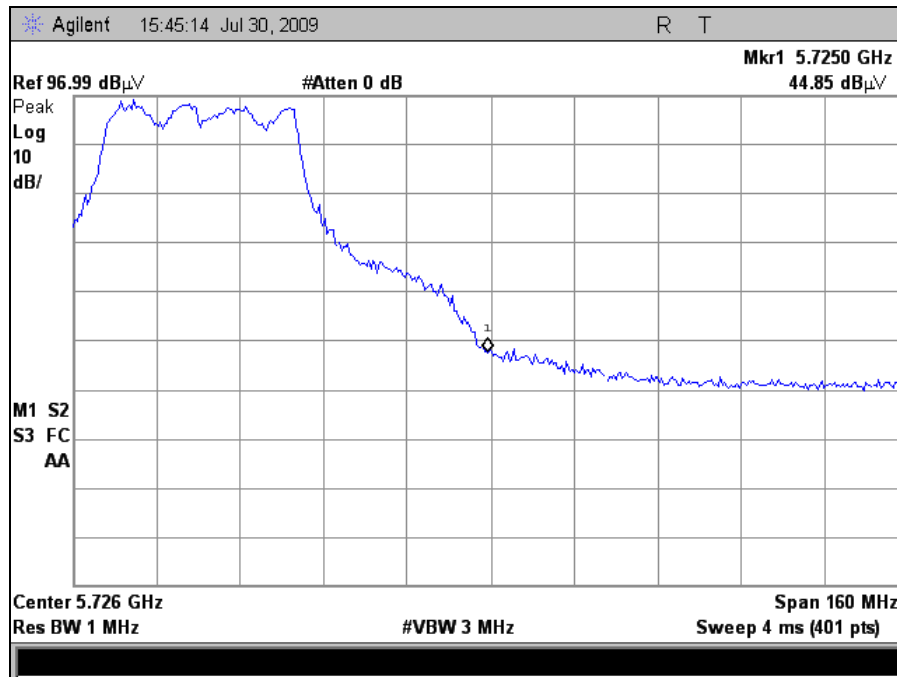

Plot 249. EIRP, 802.11n 40MHz, 5725 MHz Peak, 16 dBi Sector

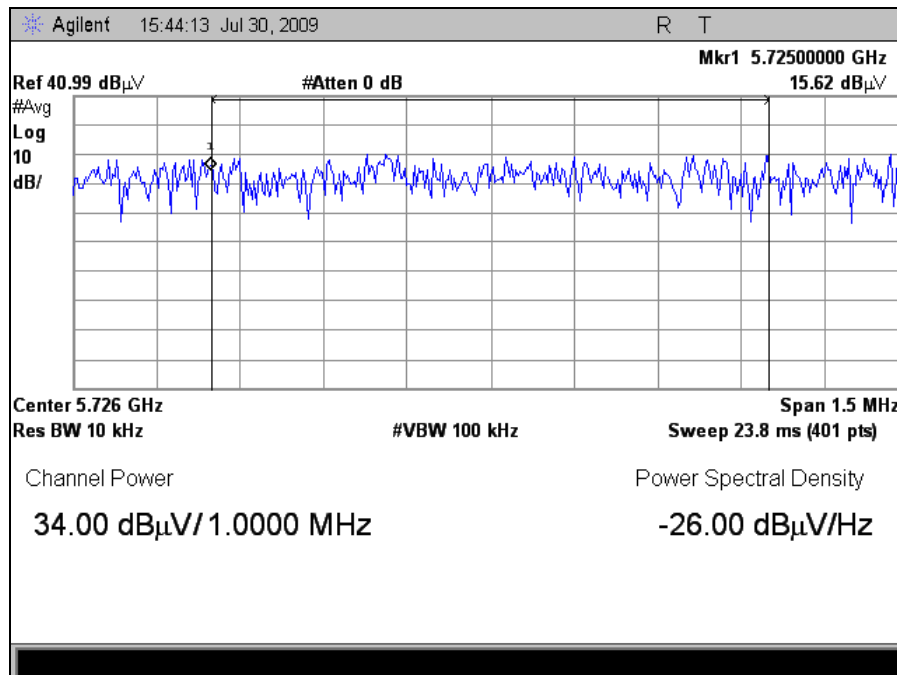

Plot 250. EIRP, 802.11n 40MHz, 5725 MHz Over 1 MHz, 16 dBi Sector

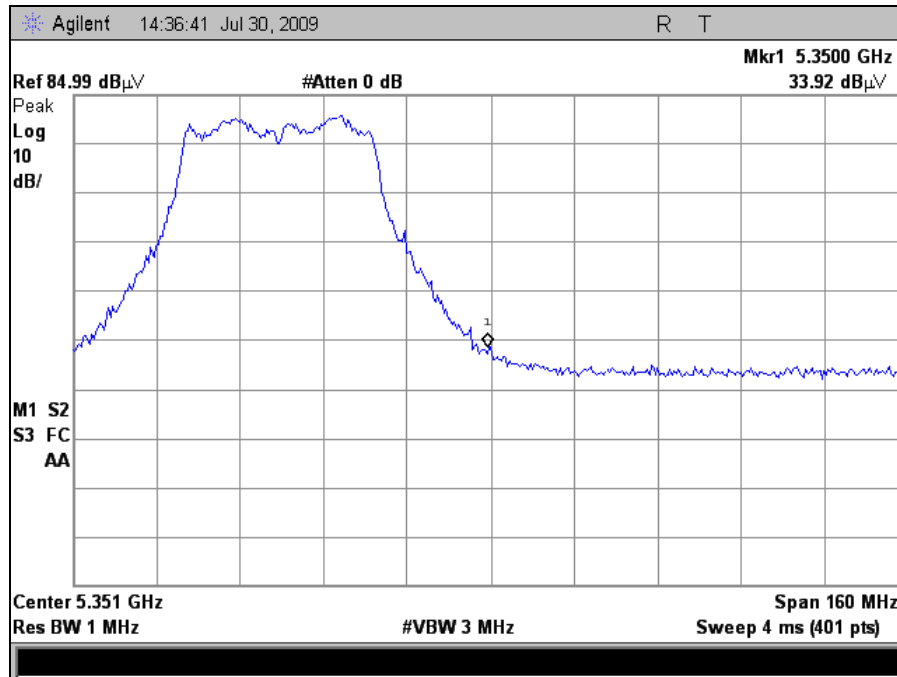

Plot 251. EIRP, 802.11n 40MHz, 5350 MHz Peak, 19 dBi Panel

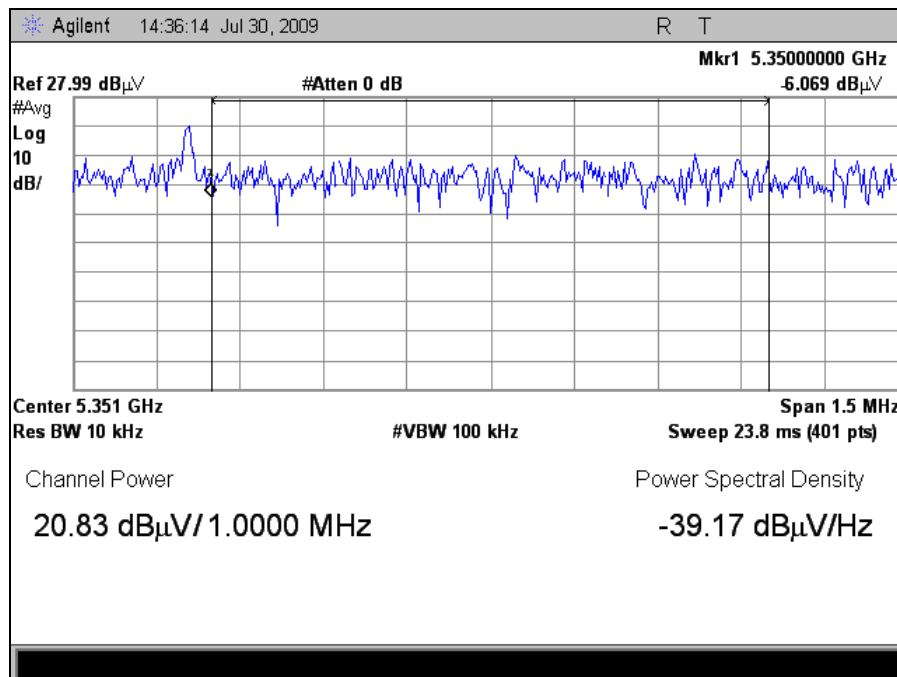

Plot 252. EIRP, 802.11n 40MHz, 5350 MHz Over 1 MHz, 19 dBi Panel

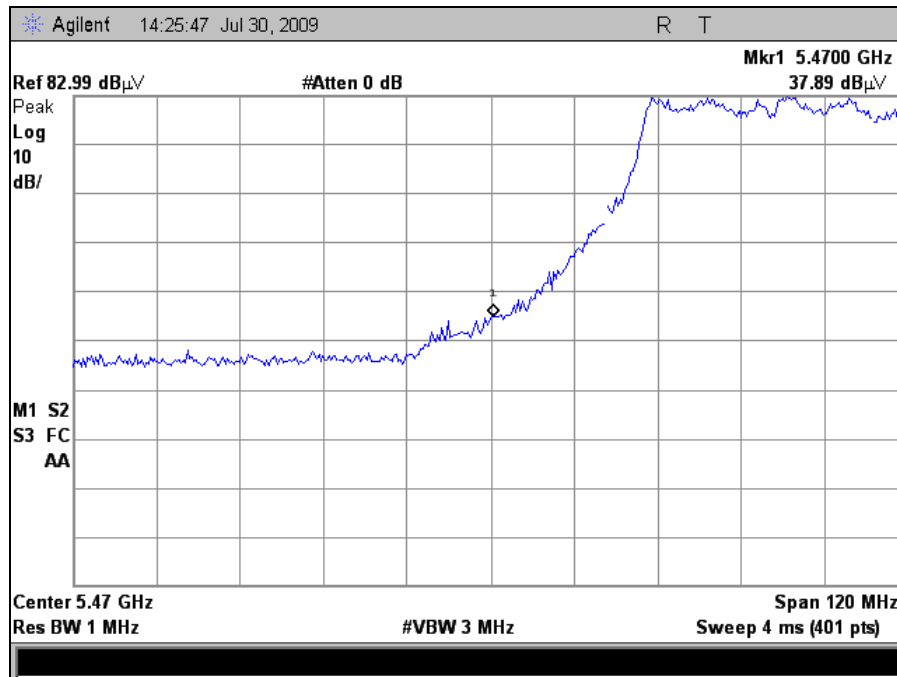

Plot 253. EIRP, 802.11n 40MHz, 5470 MHz Peak, 19 dBi Panel

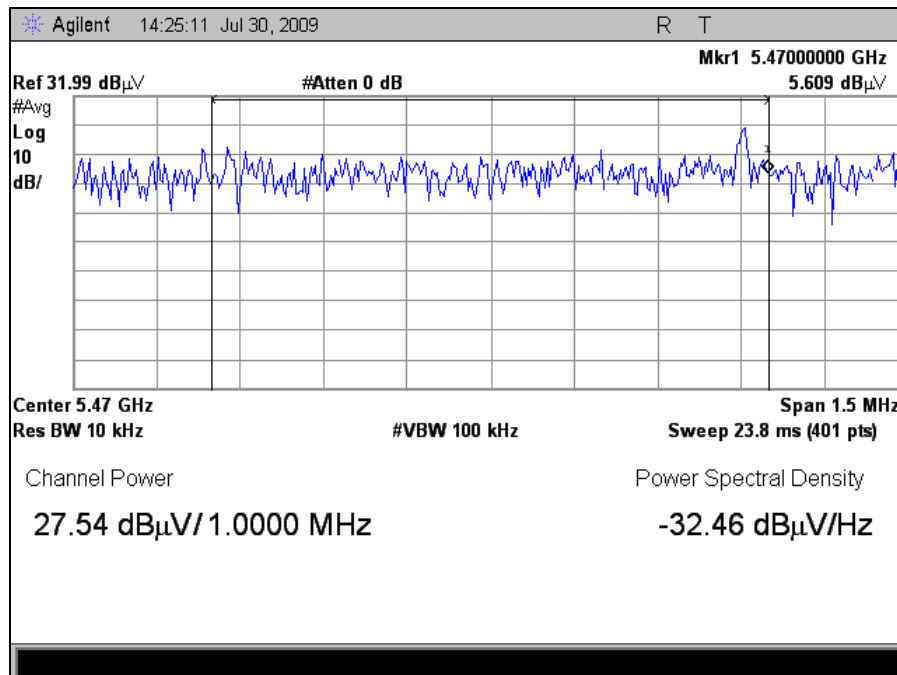

Plot 254. EIRP, 802.11n 40MHz, 5470 MHz Over 1 MHz, 19 dBi Panel

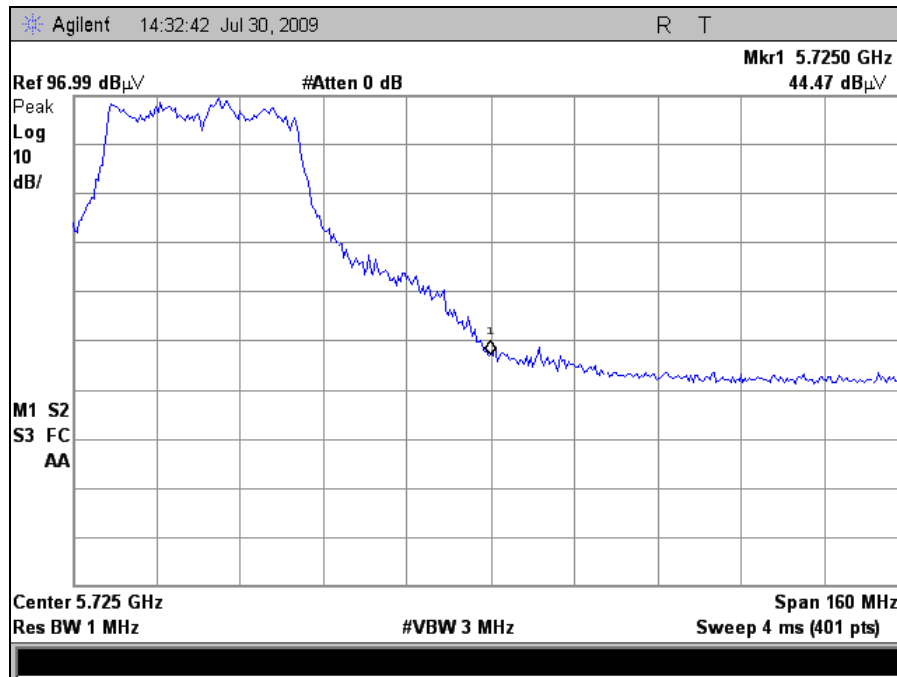

Plot 255. EIRP, 802.11n 40MHz, 5725 MHz Peak, 19 dBi Panel

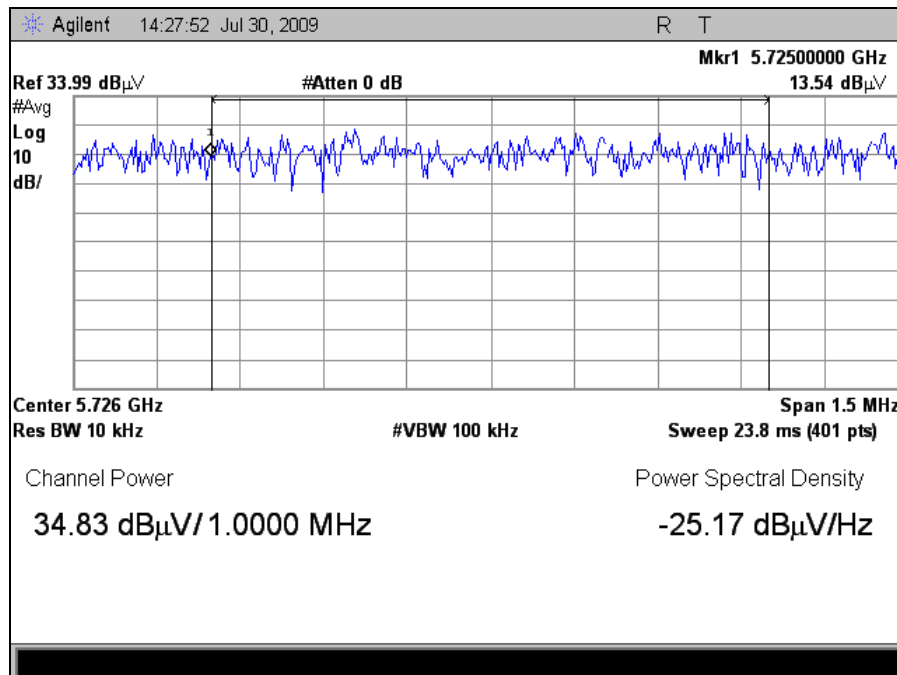

Plot 256. EIRP, 802.11n 40MHz, 5725 MHz Over 1 MHz, 19 dBi Panel

Restricted Band

9dBi Omni Antenna									
	Restricted Band Freq.	Uncorrected Peak (dBuV)	Cable Loss	ACF	DCF	Corrected	Limit (dBuV/m)	Margin	
802.11a	5350 MHz	30.93	7.03	35	9.54	63.42	74	-10.58	Peak
	5350 MHz	19.77	7.03	35	9.54	52.26	54	-1.74	Average
	5460 MHz	31.51	7.03	35	9.54	64	74	-10	Peak
	5460 MHz	19.29	7.03	35	9.54	51.78	54	-2.22	Average
802.11n 20MHz	Restricted Band Freq.	Uncorrected Peak (dBuV)	Cable Loss	ACF	DCF	Corrected	Limit (dBuV/m)	Margin	
	5350 MHz	33.29	7.03	35	9.54	65.78	74	-8.22	Peak
	5350 MHz	20.85	7.03	35	9.54	53.34	54	-0.66	Average
	5460 MHz	33.04	7.03	35	9.54	65.53	74	-8.47	Peak
	5460 MHz	20.85	7.03	35	9.54	53.34	54	-0.66	Average
802.11n 40MHz	Restricted Band Freq.	Uncorrected Peak (dBuV)	Cable Loss	ACF	DCF	Corrected	Limit (dBuV/m)	Margin	
	5350 MHz	32.27	7.03	35	9.54	64.76	74	-9.24	Peak
	5350 MHz	20.89	7.03	35	9.54	53.38	54	-0.62	Average
	5460 MHz	30.62	7.03	35	9.54	63.11	74	-10.89	Peak
	5460 MHz	19.81	7.03	35	9.54	52.3	54	-1.7	Average

Table 75. Restricted Band Edge, Radiated, Test Results, 9 dBi Omni

16dBi Sector Antenna									
	Restricted Band Freq.	Uncorrected Peak (dBuV)	Cable Loss	ACF	DCF	Corrected	Limit (dBuV/m)	Margin	
802.11a	5350 MHz	34.32	7.03	35	9.54	66.81	74	-7.19	Peak
	5350 MHz	20.61	7.03	35	9.54	53.1	54	-0.9	Average
	5460 MHz	33.1	7.03	35	9.54	65.59	74	-8.41	Peak
	5460 MHz	20.21	7.03	35	9.54	52.7	54	-1.3	Average
802.11n 20MHz	Restricted Band Freq.	Uncorrected Peak (dBuV)	Cable Loss	ACF	DCF	Corrected	Limit (dBuV/m)	Margin	
	5350 MHz	34.65	7.03	35	9.54	67.14	74	-6.86	Peak
	5350 MHz	20.78	7.03	35	9.54	53.27	54	-0.73	Average
	5460 MHz	34.53	7.03	35	9.54	67.02	74	-6.98	Peak
	5460 MHz	21.12	7.03	35	9.54	53.61	54	-0.39	Average
802.11n 40MHz	Restricted Band Freq.	Uncorrected Peak (dBuV)	Cable Loss	ACF	DCF	Corrected	Limit (dBuV/m)	Margin	
	5350 MHz	32.37	7.03	35	9.54	64.86	74	-9.14	Peak
	5350 MHz	21.48	7.03	35	9.54	53.97	54	-0.03	Average
	5460 MHz	32.44	7.03	35	9.54	64.93	74	-9.07	Peak
	5460 MHz	20.32	7.03	35	9.54	52.81	54	-1.19	Average

Table 76. Restricted Band Edge, Radiated, Test Results, 16 dBi Sector

19dBi Panel Antenna									
	Restricted Band Freq.	Uncorrected Peak (dBuV)	Cable Loss	ACF	DCF	Corrected	Limit (dBuV/m)	Margin	
802.11a	5350 MHz	31.18	7.03	35	9.54	63.67	74	-10.33	Peak
	5350 MHz	19.7	7.03	35	9.54	52.19	54	-1.81	Average
	5460 MHz	32.78	7.03	35	9.54	65.27	74	-8.73	Peak
	5460 MHz	20.8	7.03	35	9.54	53.29	54	-0.71	Average
802.11n 20MHz	5350 MHz	34.47	7.03	35	9.54	66.96	74	-7.04	Peak
	5350 MHz	19.82	7.03	35	9.54	52.31	54	-1.69	Average
	5460 MHz	32.82	7.03	35	9.54	65.31	74	-8.69	Peak
	5460 MHz	21.02	7.03	35	9.54	53.51	54	-0.49	Average
802.11n 40MHz	5350 MHz	21.37	7.03	35	9.54	53.86	74	-20.14	Peak
	5350 MHz	21.37	7.03	35	9.54	53.86	54	-0.14	Average
	5460 MHz	31.71	7.03	35	9.54	64.2	74	-9.8	Peak
	5460 MHz	20.4	7.03	35	9.54	52.89	54	-1.11	Average

Table 77. Restricted Band Edge, Radiated, Test Results, 19 dBi Panel

Restricted Band, Combined Ports, 802.11a

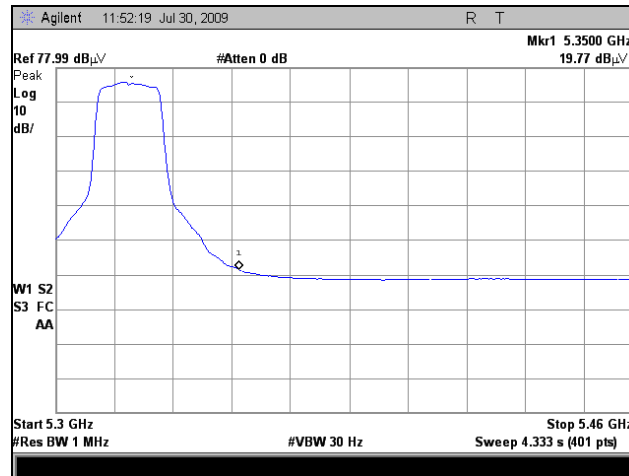

Plot 257. Restricted Band, 802.11a, 5350 Average, 9 dBi Omni

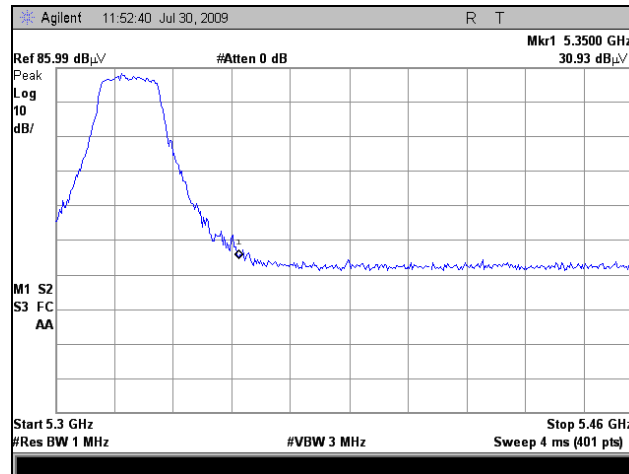

Plot 258. Restricted Band, 802.11a, 5350 Peak, 9 dBi Omni

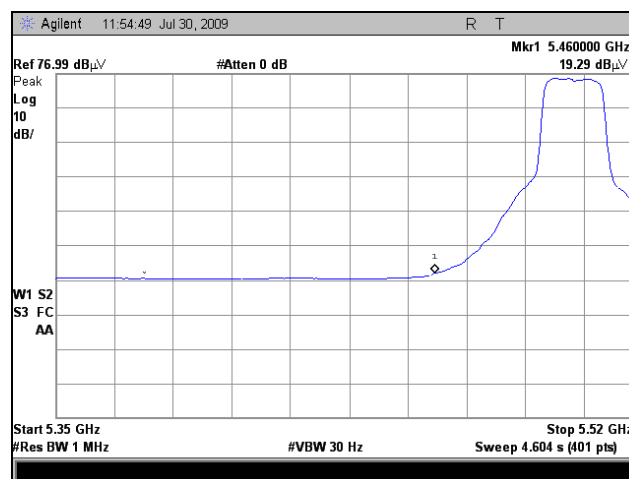

Plot 259. Restricted Band, 802.11a, 5460 Average, 9 dBi Omni

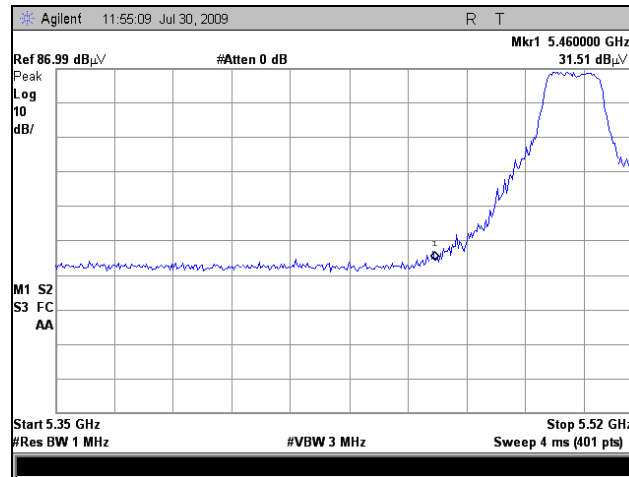

Plot 260. Restricted Band, 802.11a, 5460 Peak, 9 dBi Omni

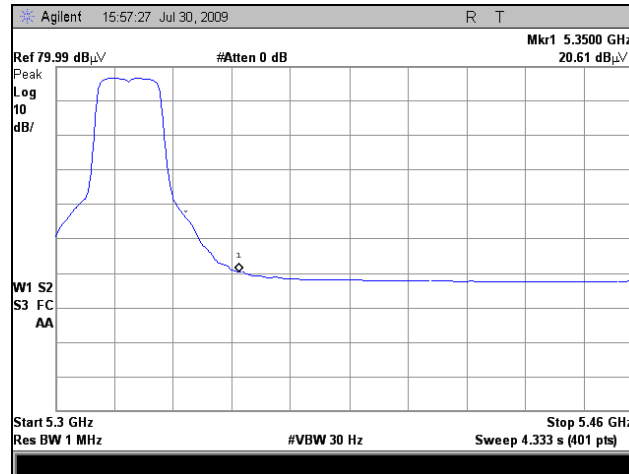

Plot 261. Restricted Band, 802.11a, 5350 Average, 16 dBi Sector

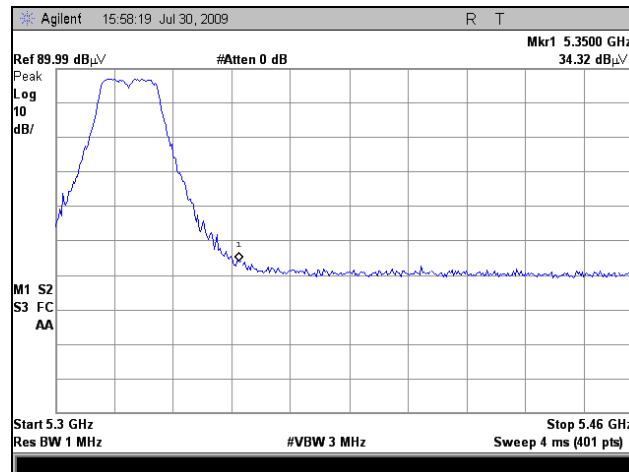

Plot 262. Restricted Band, 802.11a, 5350 Peak, 16 dBi Sector

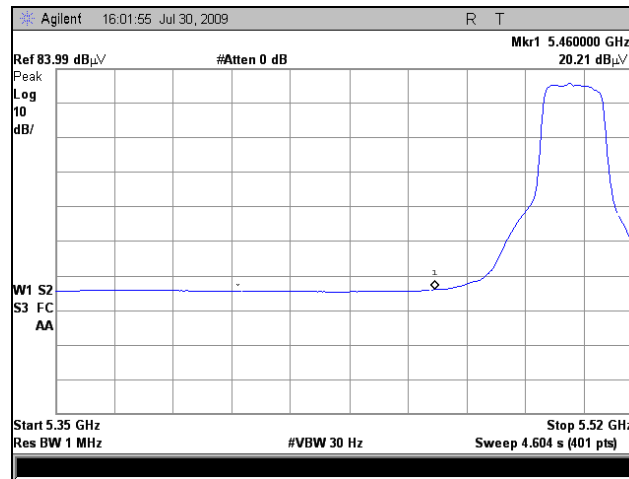

Plot 263. Restricted Band, 802.11a, 5460 Average, 16 dBi Sector

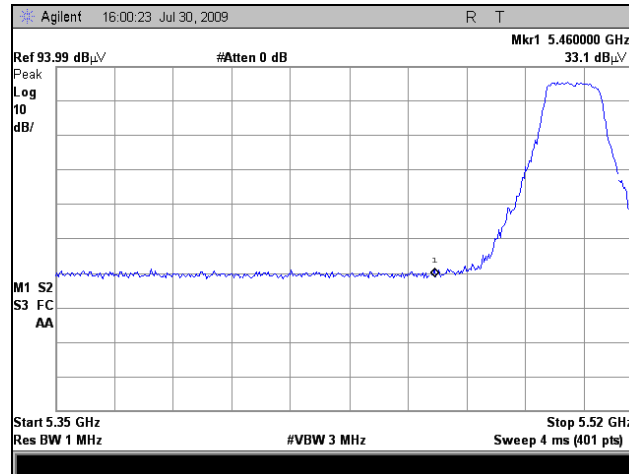

Plot 264. Restricted Band, 802.11a, 5460 Peak, 16 dBi Sector

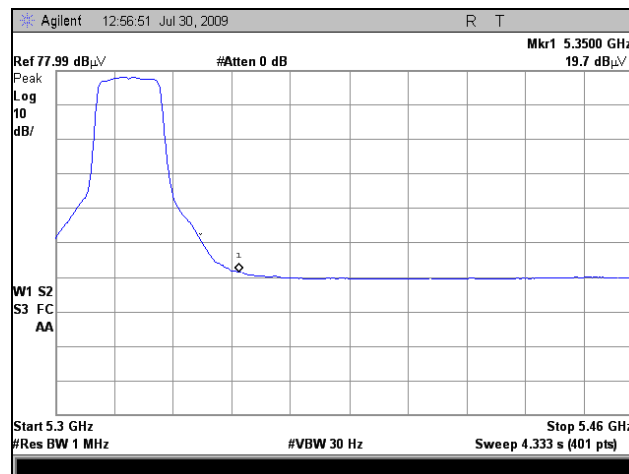

Plot 265. Restricted Band, 802.11a, 5350 Average, 19 dBi Panel

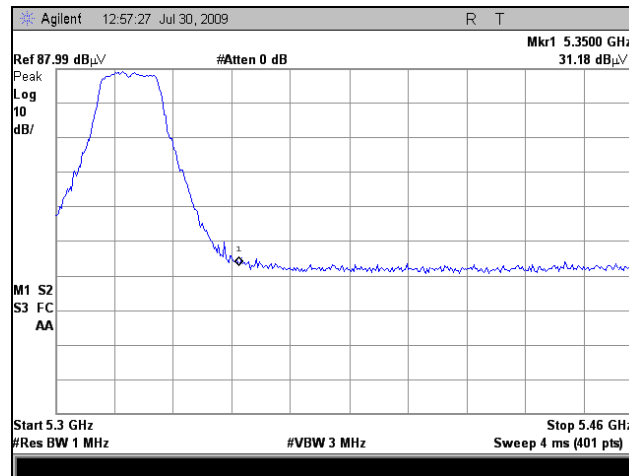

Plot 266. Restricted Band, 802.11a, 5350 Peak, 19 dBi Panel



Plot 267. Restricted Band, 802.11a, 5460 Average, 19 dBi Panel

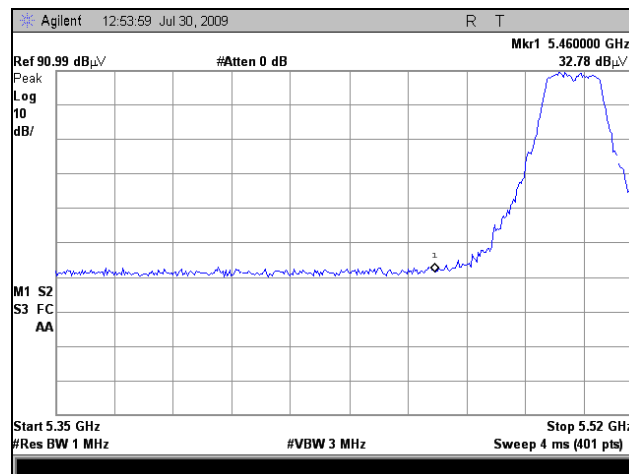

Plot 268. Restricted Band, 802.11a, 5460 Peak, 19 dBi Panel

Restricted Band, Combined Ports, 802.11n 20MHz

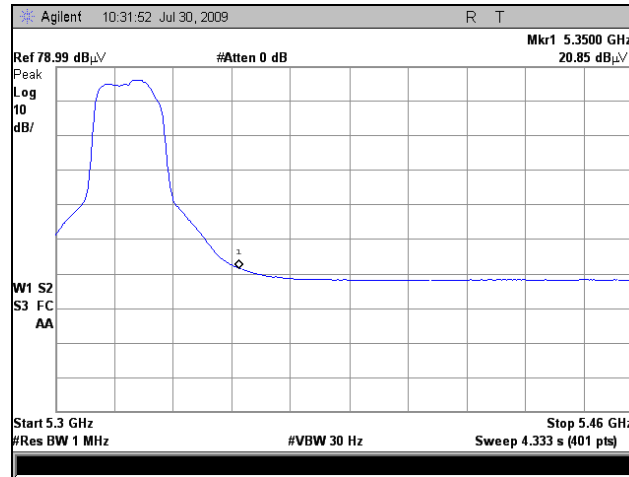

Plot 269. Restricted Band, 802.11n 20MHz, 5350 Average, 9 dBi Omni

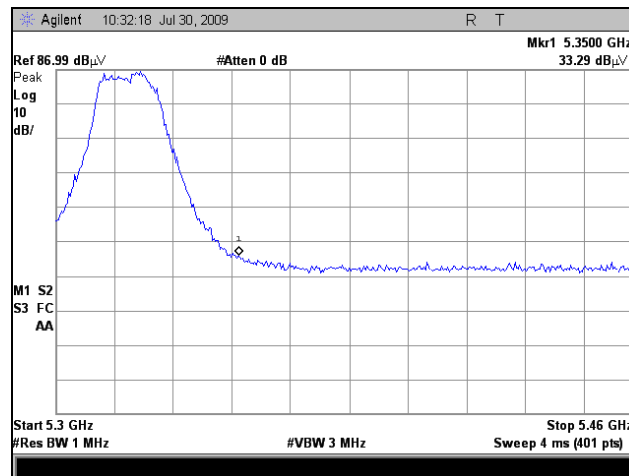

Plot 270. Restricted Band, 802.11n 20MHz, 5350 Peak, 9 dBi Omni

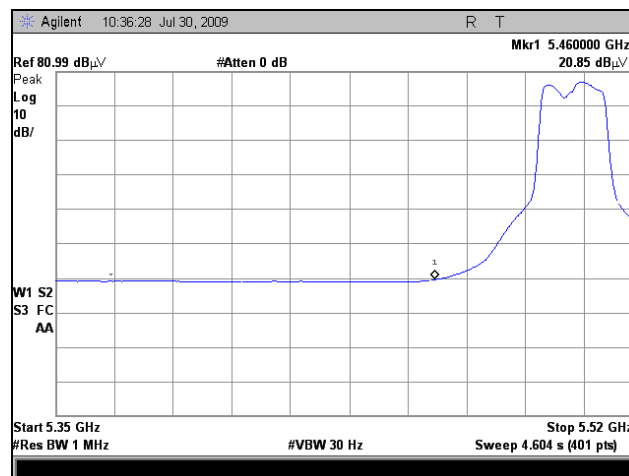

Plot 271. Restricted Band, 802.11n 20MHz, 5460 Average, 9 dBi Omni

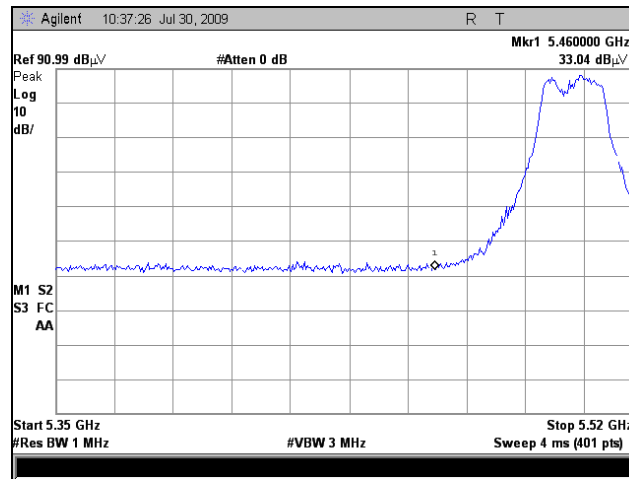

Plot 272. Restricted Band, 802.11n 20MHz, 5460 Peak, 9 dBi Omni

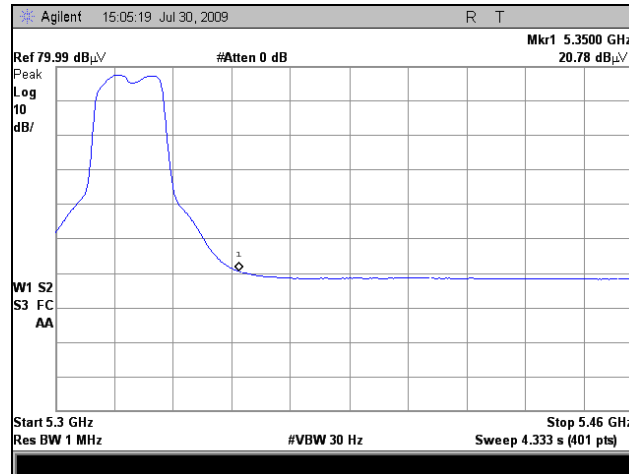

Plot 273. Restricted Band, 802.11n 20MHz, 5350 Average, 16 dBi Sector

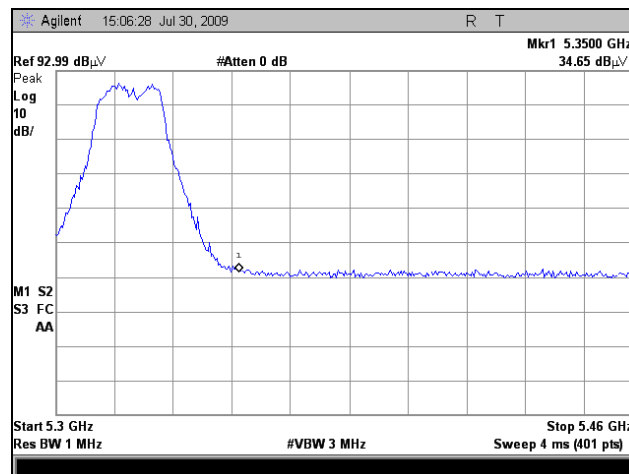

Plot 274. Restricted Band, 802.11n 20MHz, 5350 Peak, 16 dBi Sector

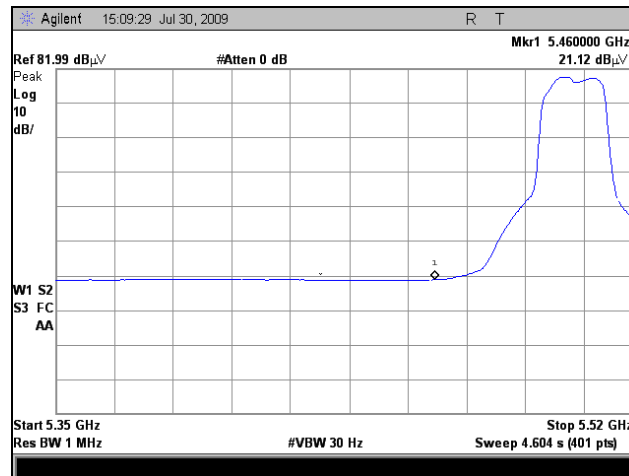

Plot 275. Restricted Band, 802.11n 20MHz, 5460 Average, 16 dBi Sector

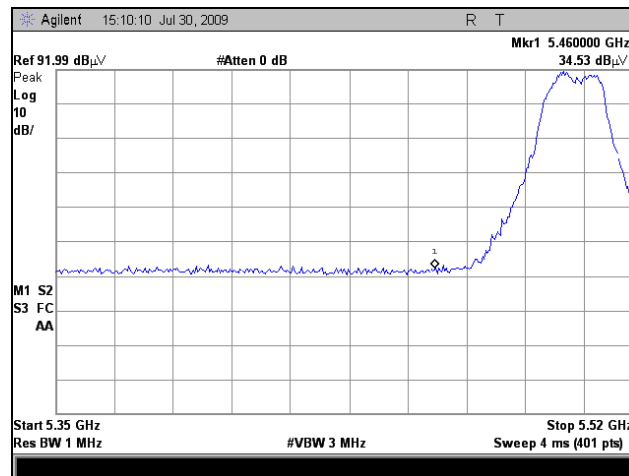

Plot 276. Restricted Band, 802.11n 20MHz, 5460 Peak, 16 dBi Sector

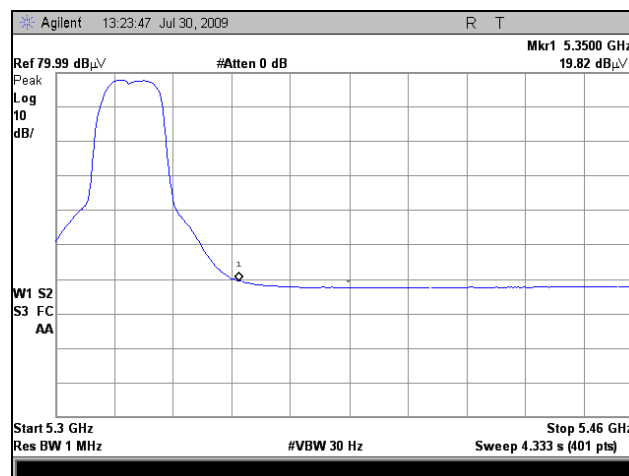

Plot 277. Restricted Band, 802.11n 20MHz, 5350 Average, 19 dBi Panel

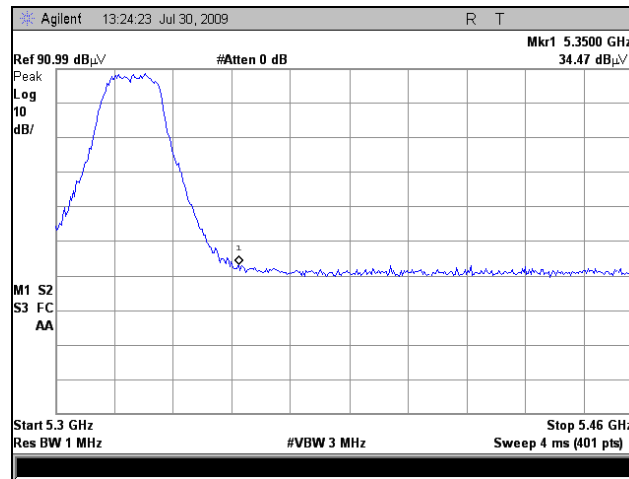

Plot 278. Restricted Band, 802.11n 20MHz, 5350 Peak, 19 dBi Panel

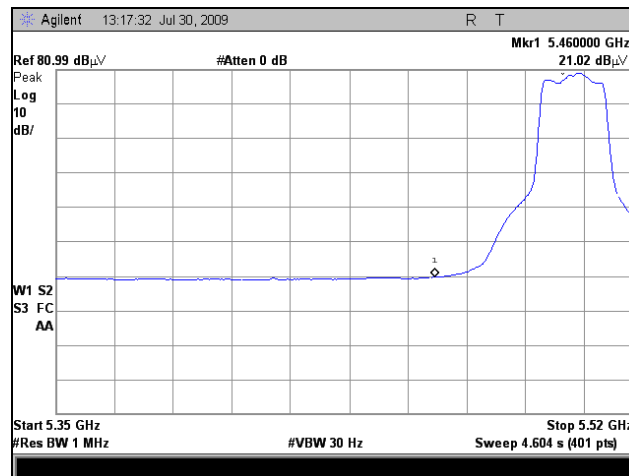

Plot 279. Restricted Band, 802.11n 20MHz, 5460 Average, 19 dBi Panel

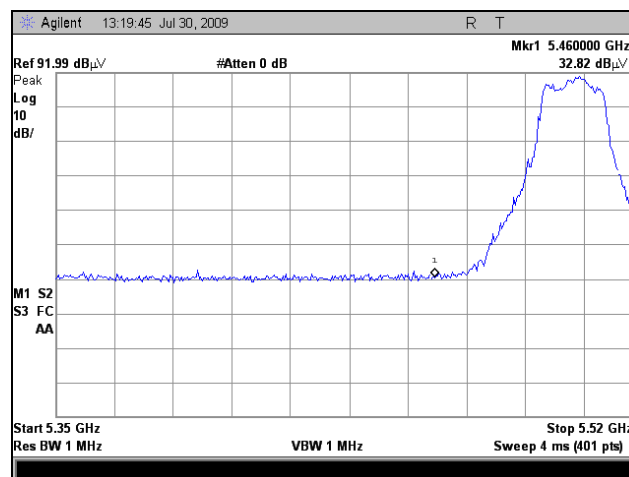

Plot 280. Restricted Band, 802.11n 20MHz, 5460 Peak, 19 dBi Panel

Restricted Band, Combined Ports, 802.11n 40MHz

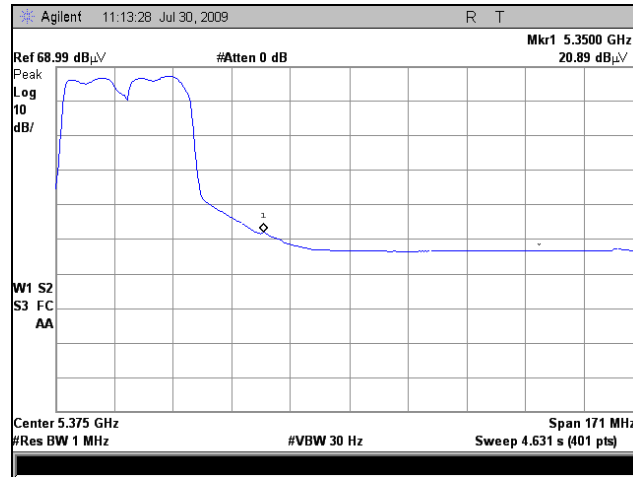

Plot 281. Restricted Band, Combined, 802.11n 40MHz, 5350 Avg., 9 dBi Omni

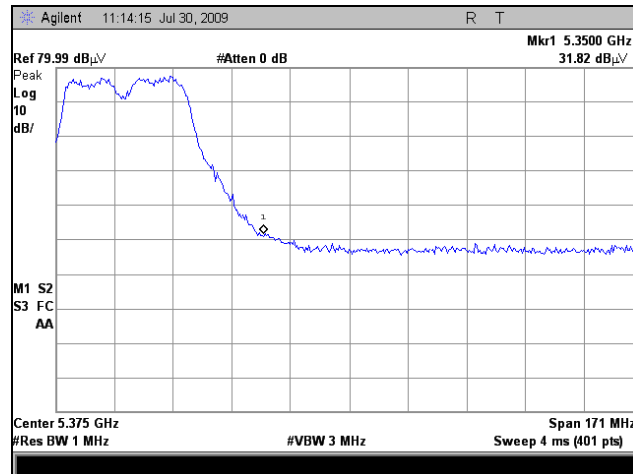

Plot 282. Restricted Band, Combined, 802.11n 40MHz, 5350 Peak, 9 dBi Omni

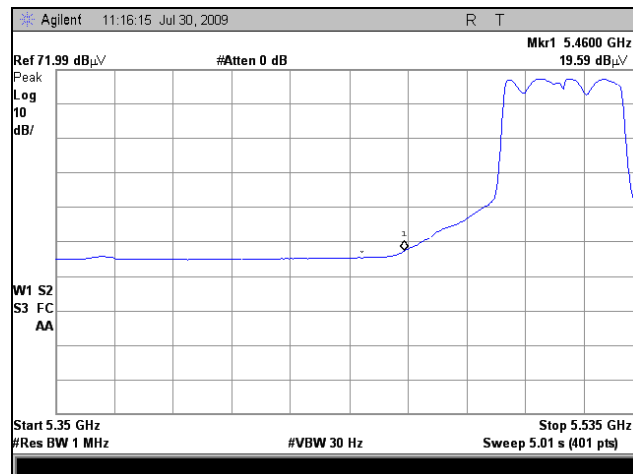

Plot 283. Restricted Band, Combined, 802.11n 40MHz, 5460 Avg., 9 dBi Omni

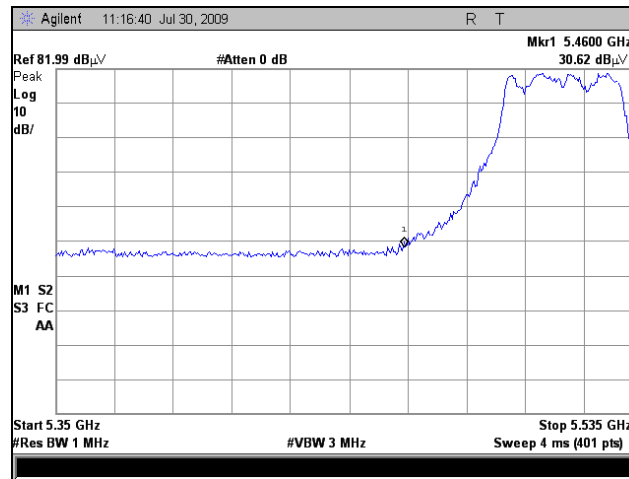

Plot 284. Restricted Band, Combined, 802.11n 40MHz, 5460 Peak, 9 dBi Omni

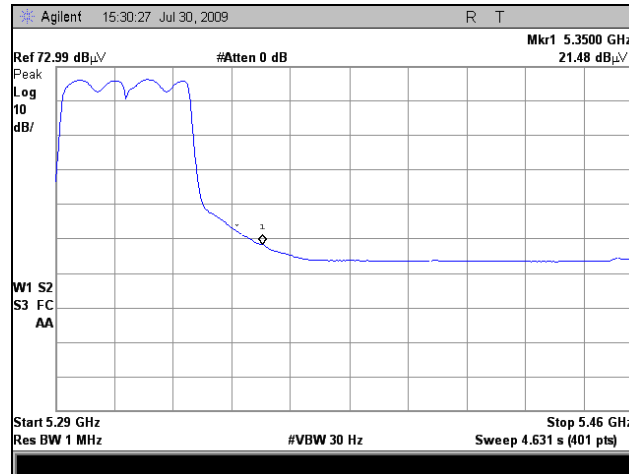

Plot 285. Restricted Band, Combined, 802.11n 40MHz, 5350 Avg., 16 dBi Sector

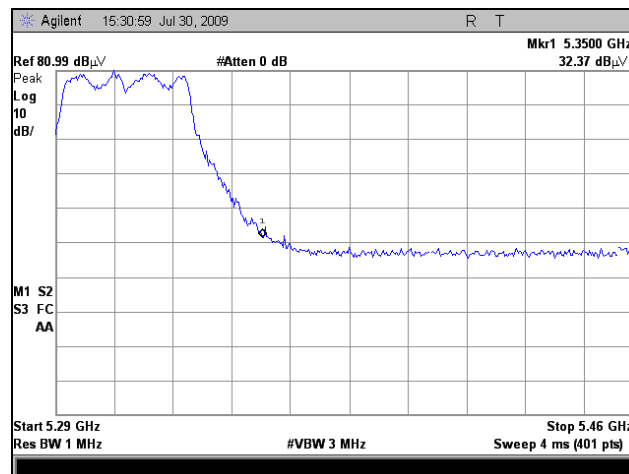

Plot 286. Restricted Band, Combined, 802.11n 40MHz, 5350 Peak, 16 dBi Sector



Plot 287. Restricted Band, Combined, 802.11n 40MHz, 5460 Avg., 16 dBi Sector

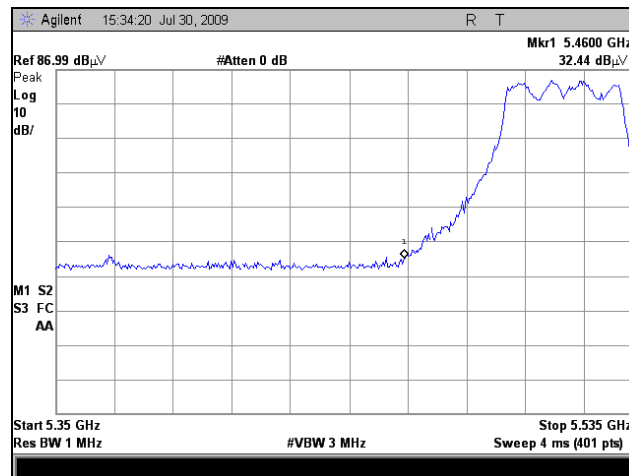

Plot 288. Restricted Band, Combined, 802.11n 40MHz, 5460 Peak, 16 dBi Sector

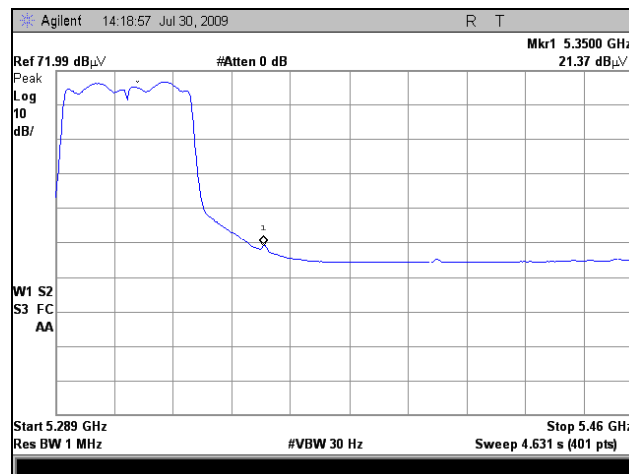

Plot 289. Restricted Band, Combined, 802.11n 40MHz, 5350 Avg., 19 dBi Panel

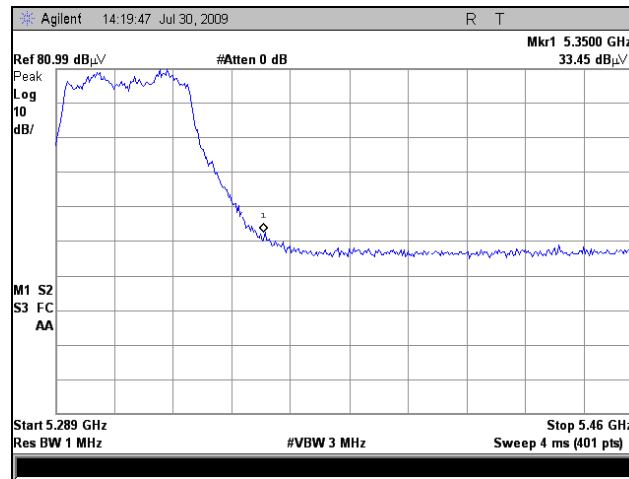

Plot 290. Restricted Band, Combined, 802.11n 40MHz, 5350 Peak, 19 dBi Panel

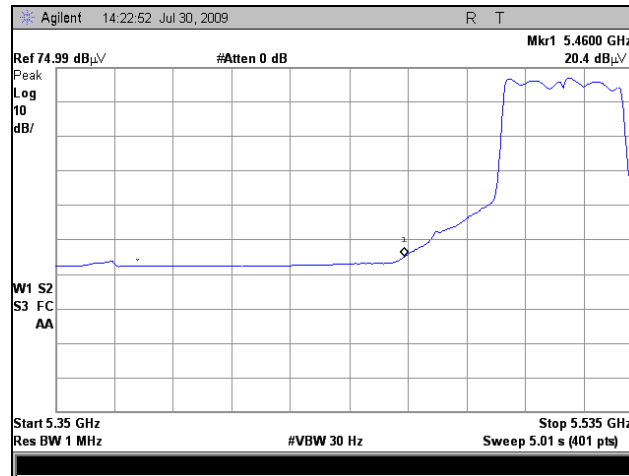

Plot 291. Restricted Band, Combined, 802.11n 40MHz, 5460 Avg., 19 dBi Panel

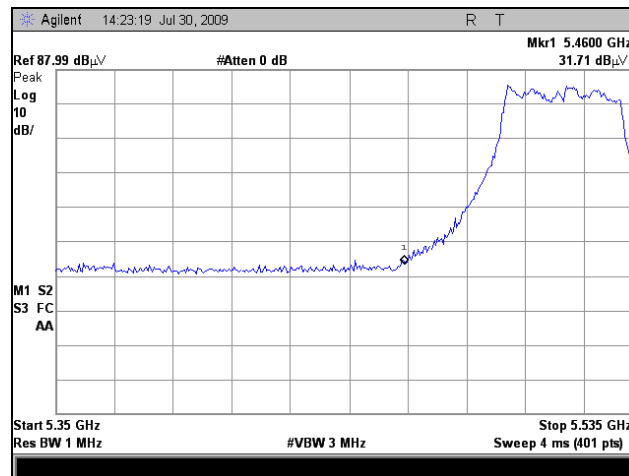

Plot 292. Restricted Band, Combined, 802.11n 40MHz, 5460 Peak, 19 dBi Panel

Electromagnetic Compatibility Criteria for Intentional Radiators

§ 15.407(f) RF Exposure

RF Exposure Requirements: §1.1307(b)(1) and §1.1307(b)(2): Systems operating under the provisions of this section shall be operated in a manner that ensures that the public is not exposed to radio frequency energy levels in excess of the Commission's guidelines.

RF Radiation Exposure Limit: §1.1310: As specified in this section, the Maximum Permissible Exposure (MPE) Limit shall be used to evaluate the environmental impact of human exposure to radiofrequency (RF) radiation as specified in Sec. 1.1307(b), except in the case of portable devices which shall be evaluated according to the provisions of Sec. 2.1093 of this chapter.

MPE Limit Calculation: EUT's operating frequencies @ 5250-5350MHz and 5470-5725MHz; highest conducted power = 20.21dBm (peak); therefore, **Limit for Uncontrolled exposure: 1 mW/cm² or 10 W/m²**

Equation from page 18 of OET 65, Edition 97-01

$$S = PG / 4\pi R^2 \quad \text{or} \quad R = \sqrt{PG / 4\pi S}$$

EUT maximum antenna gain = 9.47dBi Combined (EUT is deployed with three 5dBi Gain Omnis)

where, S = Power Density (1 mW/cm²)
P = Power Input to antenna (104.95 mW)
G = Antenna Gain (9.48 numeric)

$$S = (104.95 * 9.48 / 4 * 3.14 * 20.0) = (995.41 / 5024) = \mathbf{0.19mW/cm^2 @ 20cm separation}$$

EUT maximum antenna gain = 9 dBi Omni

where, S = Power Density (1 mW/cm²)
P = Power Input to antenna (104.95 mW)
G = Antenna Gain (7.943 numeric)

$$S = (104.95 * 7.9432 / 4 * 3.14 * 20.0^2) = (833.68 / 5024) = \mathbf{0.16mW/cm^2 @ 20cm separation}$$

EUT maximum antenna gain = 16 dBi Sector

where, S = Power Density (1 mW/cm²)
P = Power Input to antenna (104.95 mW)
G = Antenna Gain (39.81 numeric)

$$S = (104.95 * 39.81 / 4 * 3.14 * 20.0^2) = (4178.30 / 5024) = \mathbf{0.83mW/cm^2 @ 20cm separation}$$

EUT maximum antenna gain = 19 dBi Panel

where, S = Power Density (1 mW/cm²)
P = Power Input to antenna (226.98 mW)
G = Antenna Gain (79.43 numeric)

$$R = \sqrt{((104.95 * 79.432) / 4 * 3.14)} = \sqrt{(8336.81 / 12.56)} = \mathbf{25.76 cm}$$

Electromagnetic Compatibility Criteria for Intentional Radiators

§ 15.407(g) Frequency Stability

- Test Requirements:** § 15.407(g): Manufacturers of U-NII devices are responsible for ensuring frequency stability such that an emission is maintained within the band of operation under all conditions of normal operation as specified in the user's manual.
- Test Procedure:** The EUT was placed in an environmental chamber and the RF port was connected directly to a spectrum analyzer through an attenuator. Depending on which band was being investigated, the EUT was set to transmit at the low, mid, and high with the appropriate power level. If the EUT was capable of transmitting a CW carrier then the spectrum analyzer's frequency counting function was used to measure the actual frequency. If only a modulated carrier was available then the frequency relative to -10dBc above and below the carrier was measured and the carrier frequency was determined using $(f1+f2)/2$. The frequency of the carrier was measured at normal and extreme conditions. The resulting carrier frequencies were tabulated below with the temperature range of -40°C to +60°C .
- Test Results:** The EUT was found compliant with the requirements of §15.407(g)
- Test Engineer(s):** 08/19/09 – 08/20/09
- Test Date(s):** Anderson Soungpanya

Port	Frequency (MHz)	Voltage	Temperature (C)	Measured (MHz)	Δ ppm
Port 1	5320	Low	-40	5319.95800	7.89
	5320	High	-40	5319.95625	8.22
	5500	Low	-40	5499.95275	8.59
	5500	High	-40	5499.95450	8.27
	5700	Low	-40	5699.95100	8.60
	5700	High	-40	5699.94750	9.21
	5320	Low	60	5320.14175	26.64
	5320	High	60	5320.14875	27.96
	5500	Low	60	5500.15750	28.64
	5500	High	60	5500.15750	28.64
	5700	Low	60	5700.16275	28.55
	5700	High	60	5700.13475	23.64

	Frequency (MHz)	Voltage	Temperature (C)	Measured (MHz)	Δ ppm
Port 2	5320	Low	-40	5319.94925	9.54
	5320	High	-40	5319.95450	8.55
	5500	Low	-40	5499.94750	9.55
	5500	High	-40	5499.94925	9.23
	5700	Low	-40	5699.94400	9.82
	5700	High	-40	5699.94750	9.21
	5320	Low	60	5320.04025	7.57
	5320	High	60	5320.05425	10.20
	5500	Low	60	5500.05075	9.23
	5500	High	60	5500.05075	9.23
	5700	Low	60	5700.05250	9.21
	5700	High	60	5700.06300	11.05

	Frequency (MHz)	Voltage	Temperature (C)	Measured (MHz)	Δ ppm
Port 3	5320	Low	-40	5319.95100	9.21
	5320	High	-40	5319.94925	9.54
	5500	Low	-40	5499.94750	9.55
	5500	High	-40	5499.94925	9.23
	5700	Low	-40	5699.94575	9.52
	5700	High	-40	5699.94575	9.52
	5320	Low	60	5320.12950	24.34
	5320	High	60	5320.14700	27.63
	5500	Low	60	5500.11725	21.32
	5500	High	60	5500.15400	28.00
	5700	Low	60	5700.12075	21.18
	5700	High	60	5700.09800	17.19

Frequency Stability, Port 1

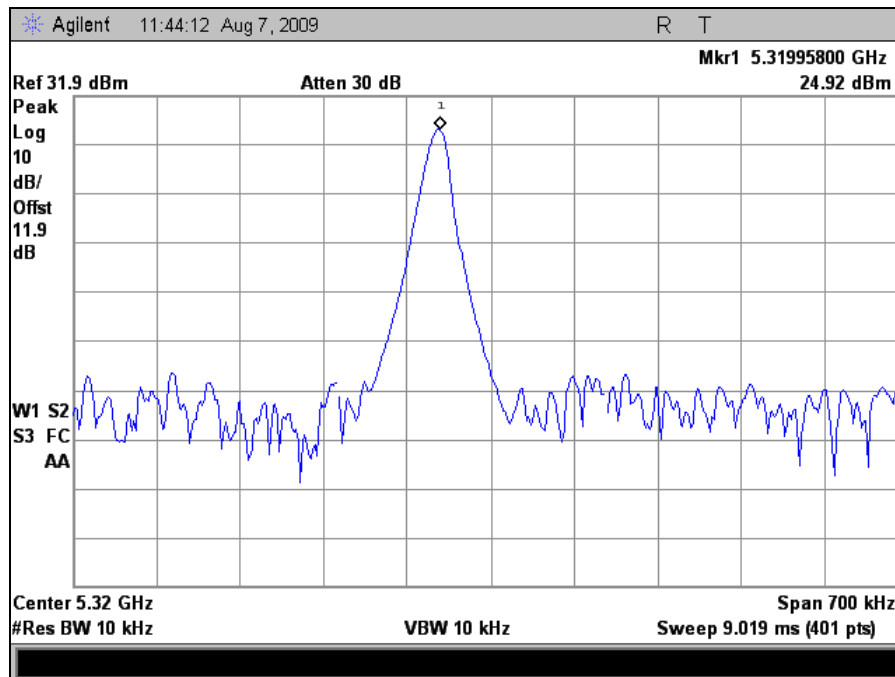

Plot 293. Freq. Stability, Port 1, 5320 MHz @ -40C Low Volt.

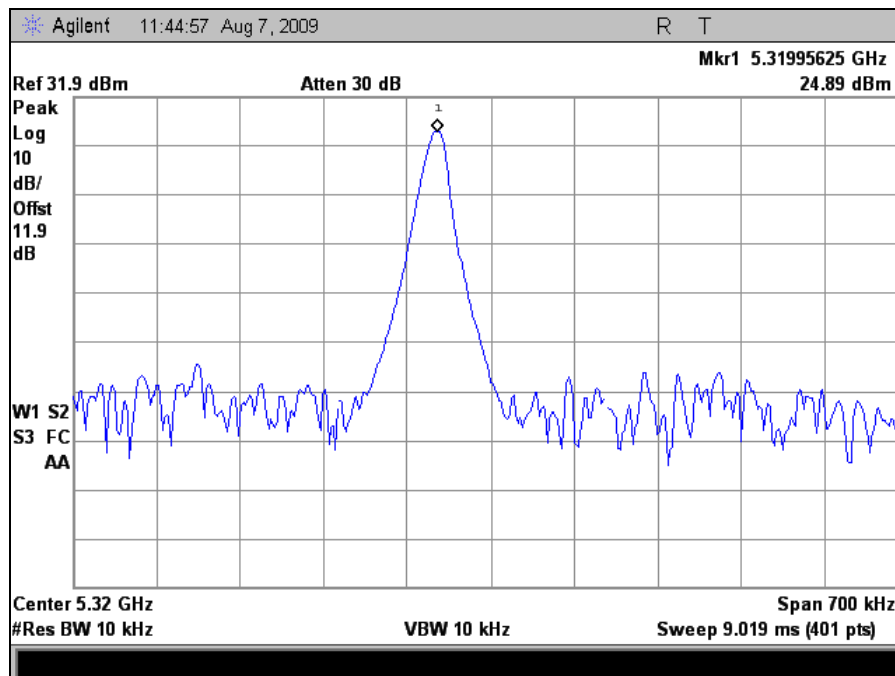

Plot 294. Freq. Stability, Port 1, 5320 MHz @ -40C High Volt.

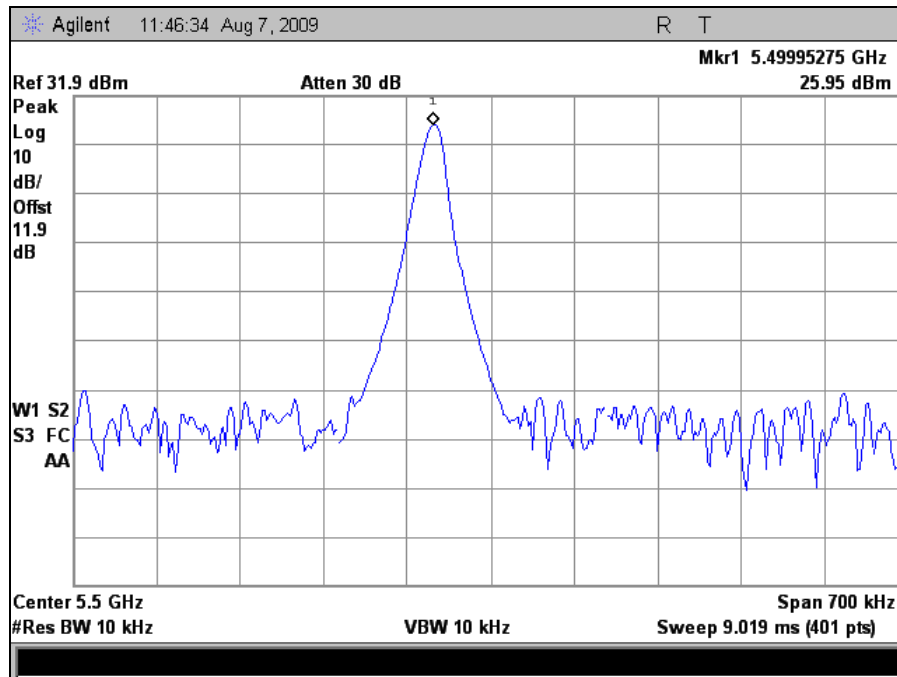

Plot 295. Freq. Stability, Port 1, 5500 MHz @-40C Low Volt.

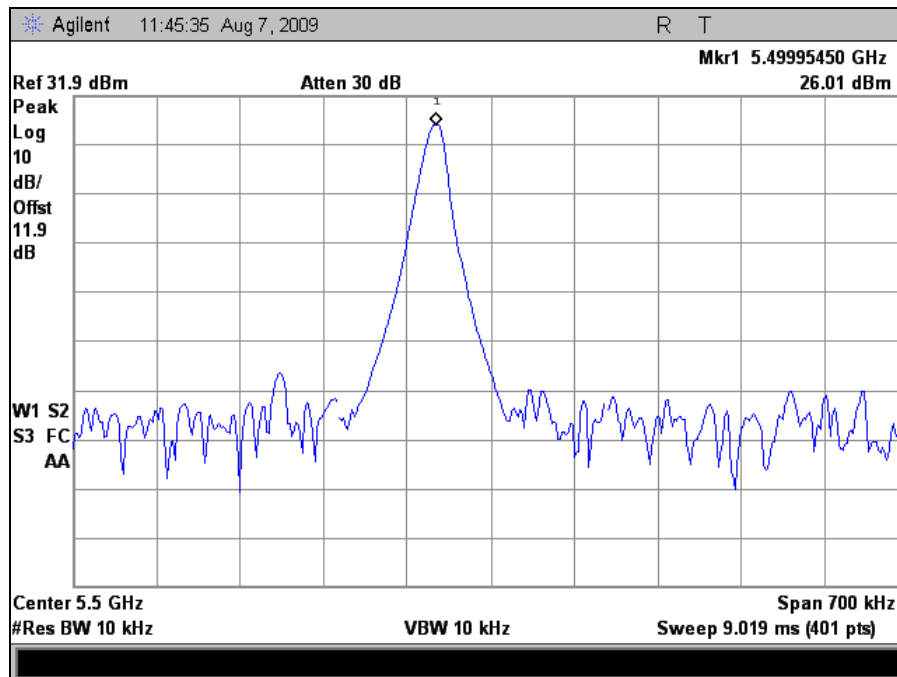

Plot 296. Freq. Stability, Port 1, 5500 MHz @-40C High Volt.

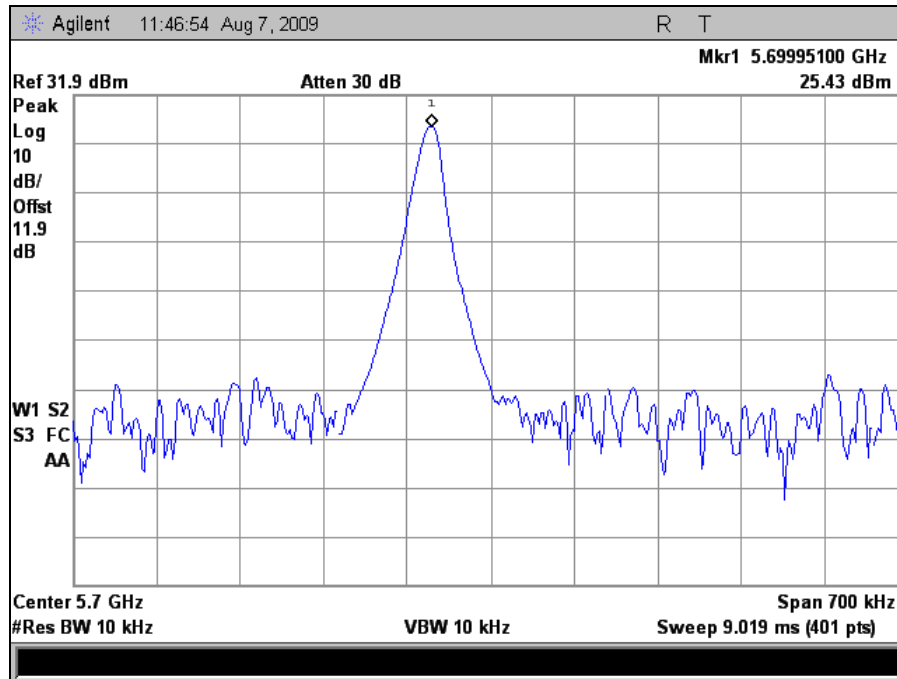

Plot 297. Freq. Stability, Port 1, 5700 MHz @-40C Low Volt.

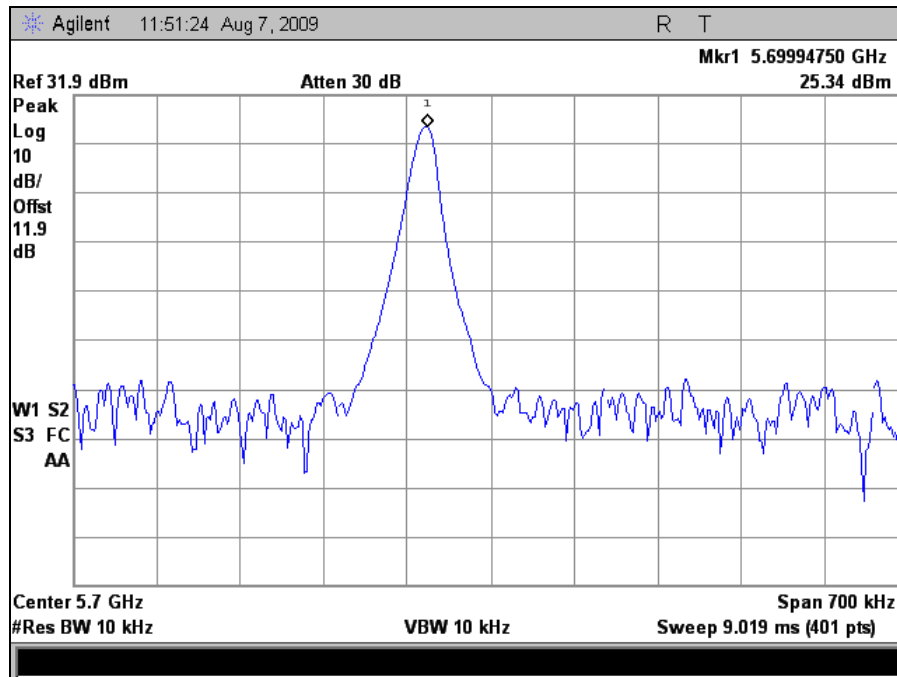

Plot 298. Freq. Stability, Port 1, 5700 MHz @-40C High Volt.

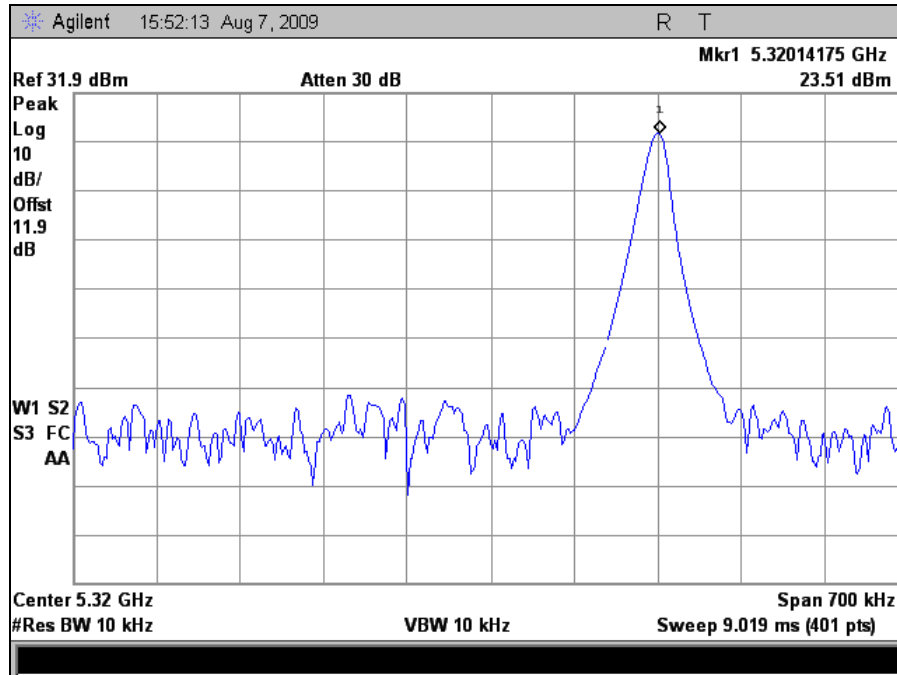

Plot 299. Freq. Stability, Port 1, 5320 MHz @+60C Low Volt.

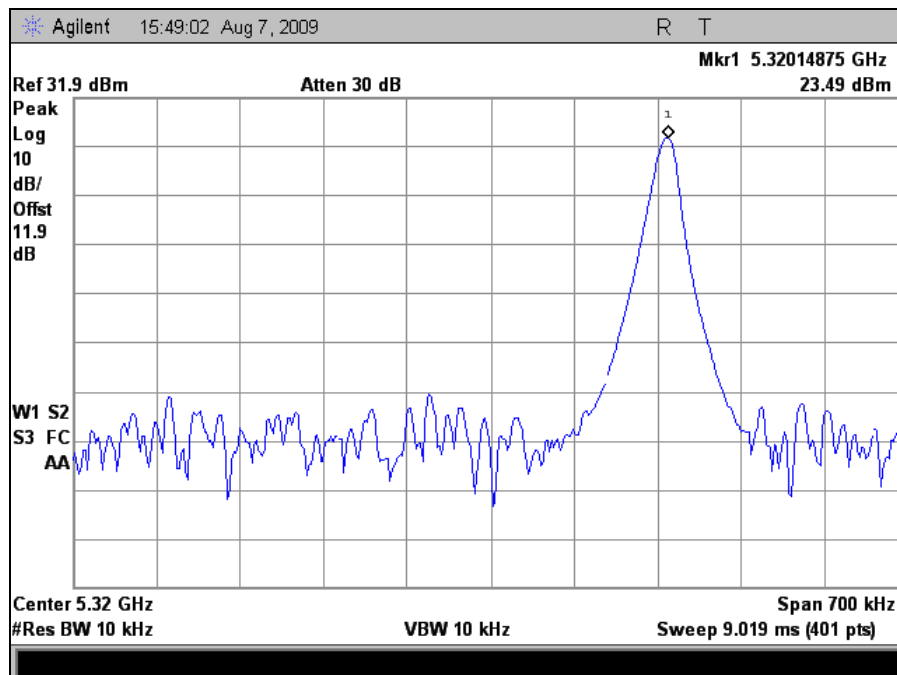

Plot 300. Freq. Stability, Port 1, 5320 MHz @+60C High Volt.

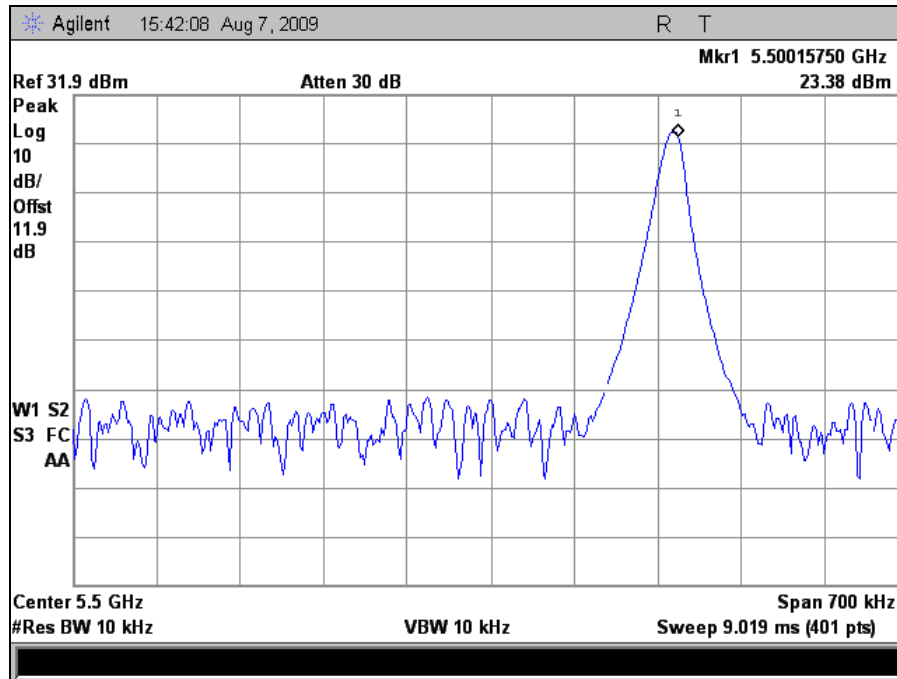

Plot 301. Freq. Stability, Port 1, 5500 MHz @+60C Low Volt.

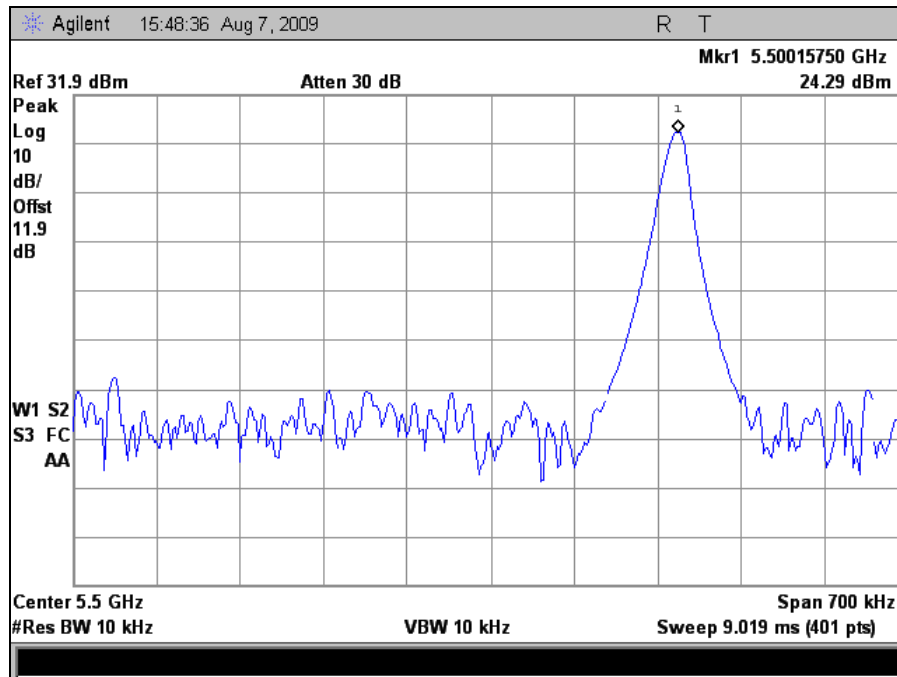

Plot 302. Freq. Stability, Port 1, 5500 MHz @+60C High Volt.

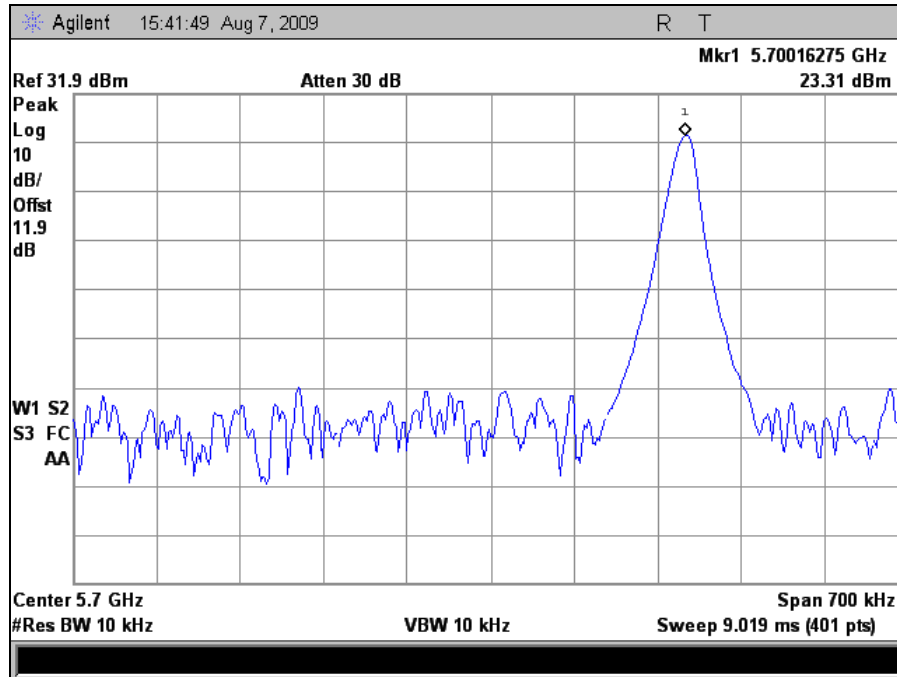

Plot 303. Freq. Stability, Port 1, 5700 MHz @+60C Low Volt.

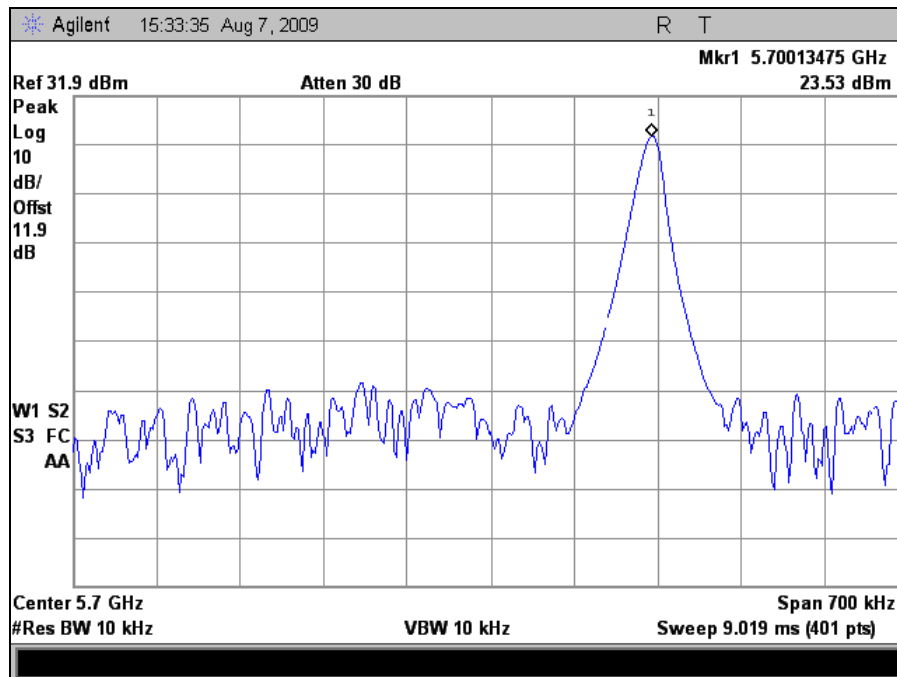

Plot 304. Freq. Stability, Port 1, 5700 MHz @+60C High Volt.

Frequency Stability, Port 2

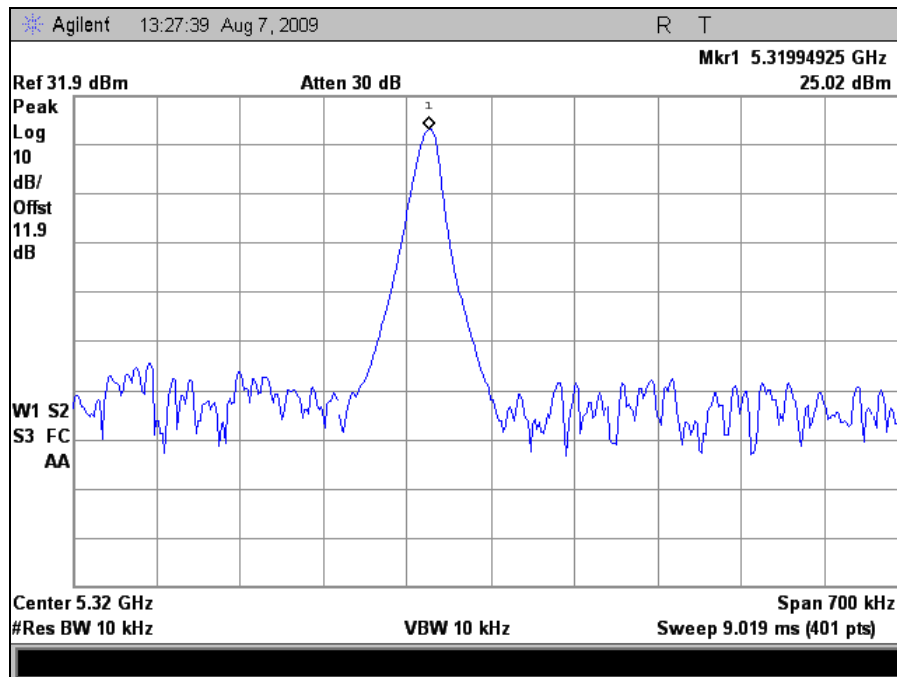

Plot 305. Freq. Stability, Port 2, 5320 MHz @ -40C Low Volt.

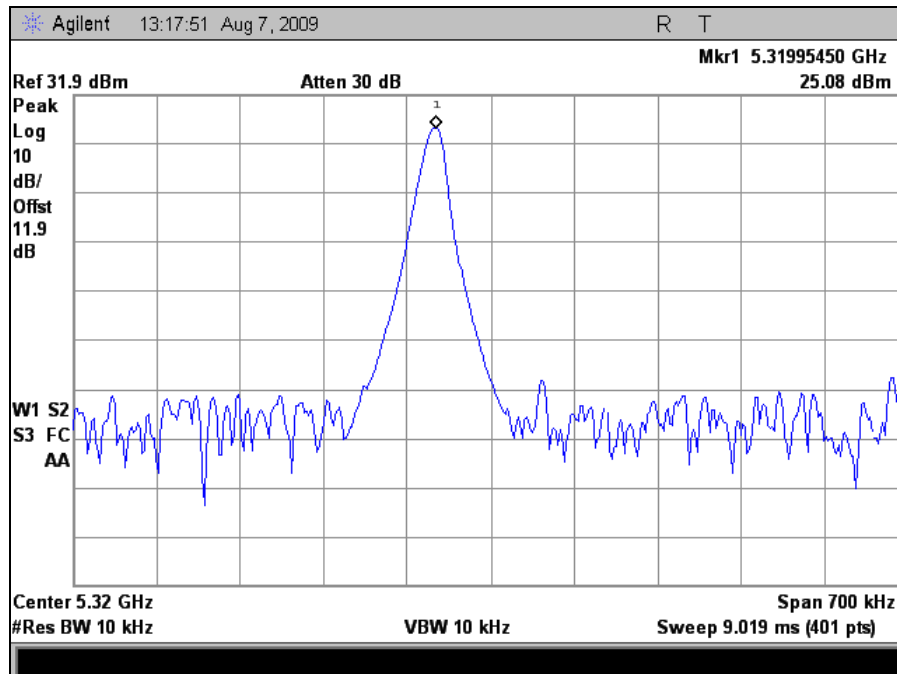

Plot 306. Freq. Stability, Port 2, 5320 MHz @ -40C High Volt.

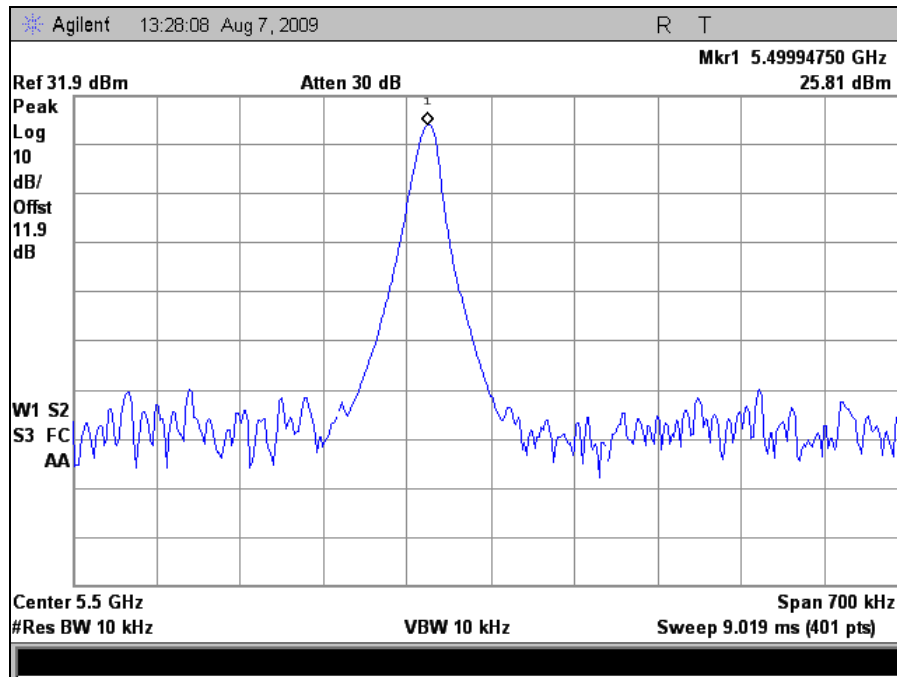

Plot 307. Freq. Stability, Port 2, 5500 MHz @-40C Low Volt.

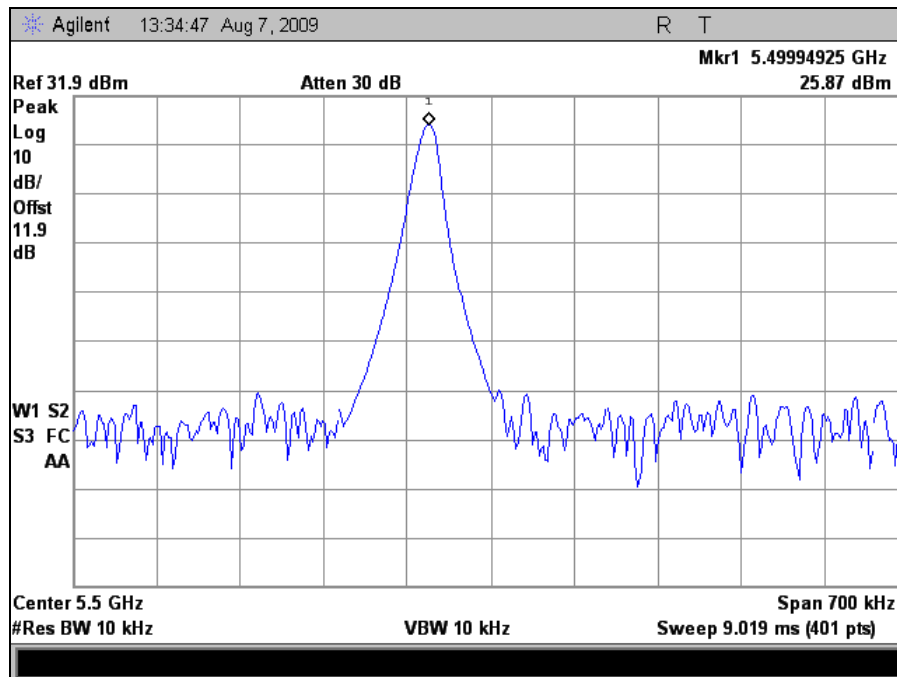

Plot 308. Freq. Stability, Port 2, 5500 MHz @-40C High Volt.

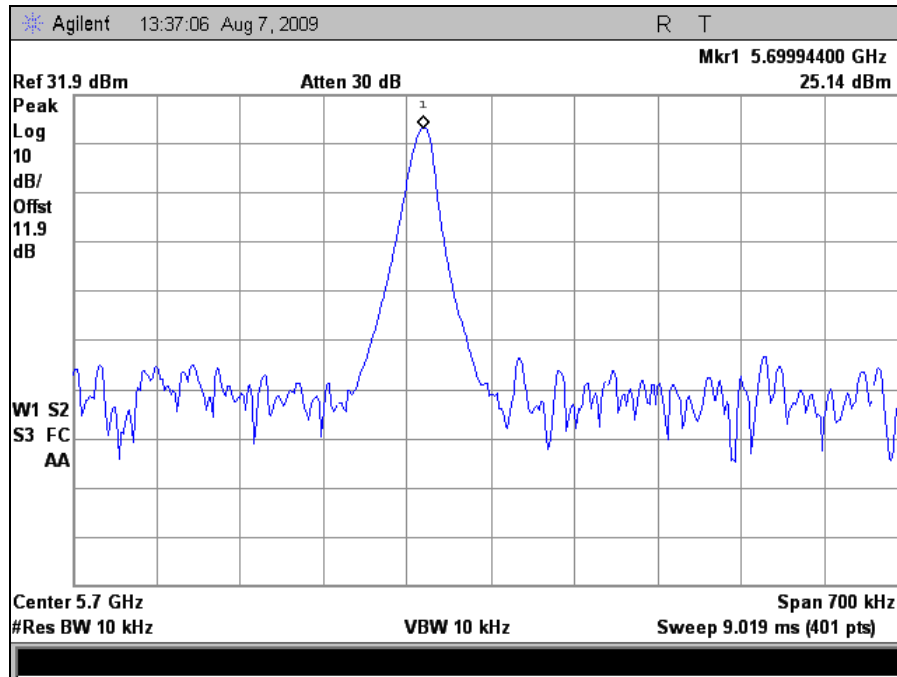

Plot 309. Freq. Stability, Port 2, 5700 MHz @-40C Low Volt.

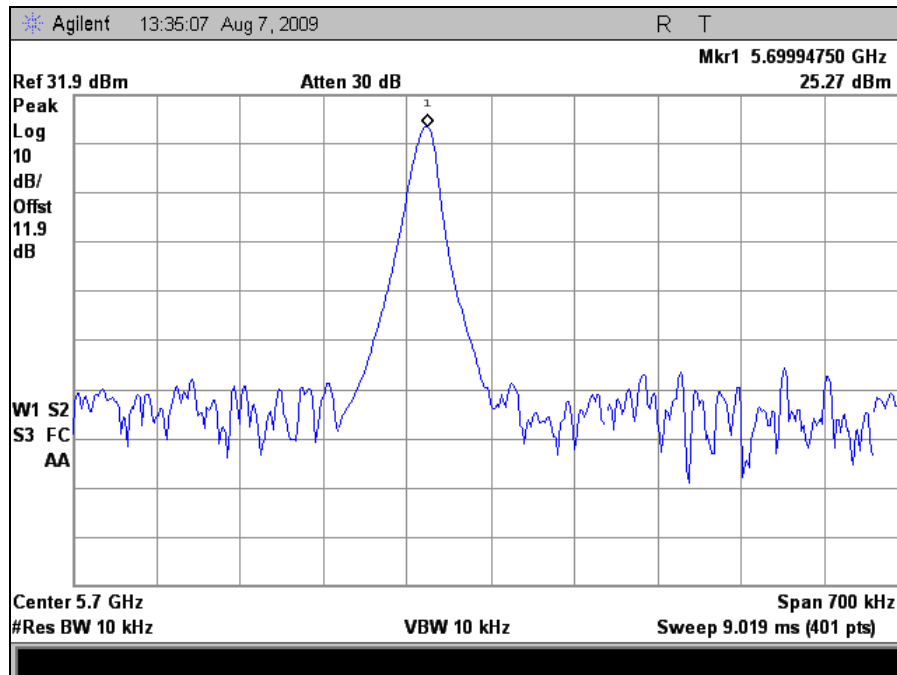

Plot 310. Freq. Stability, Port 2, 5700 MHz @-40C High Volt.

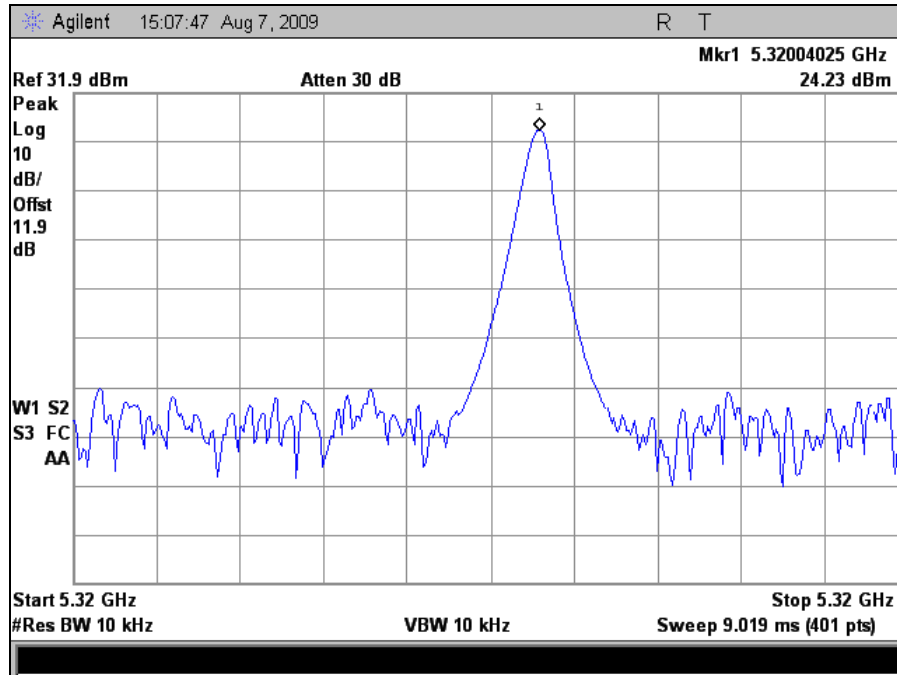

Plot 311. Freq. Stability, Port 2, 5320 MHz @+60C Low Volt.

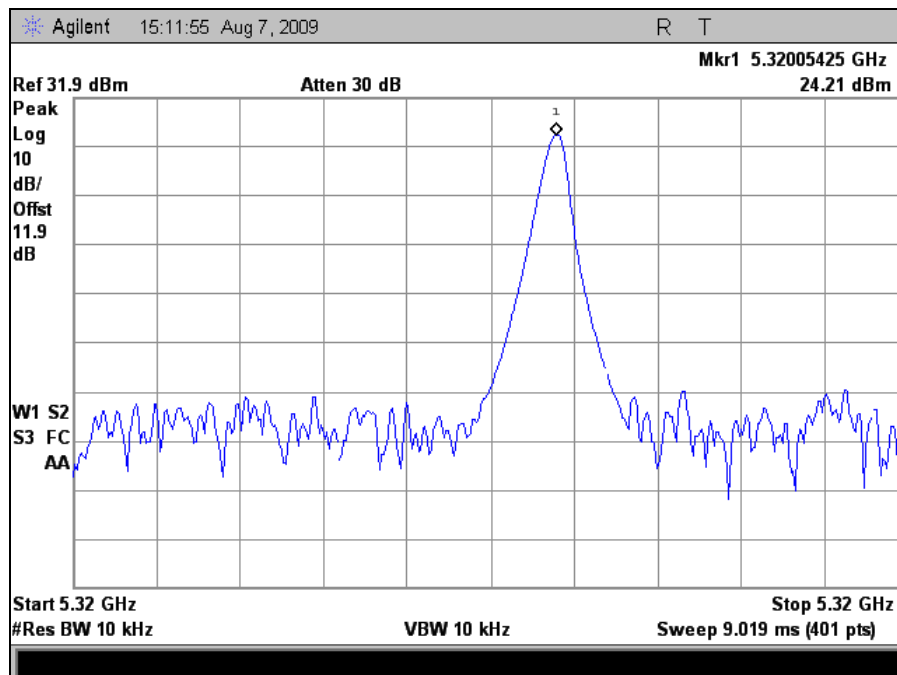

Plot 312. Freq. Stability, Port 2, 5320 MHz @+60C High Volt.

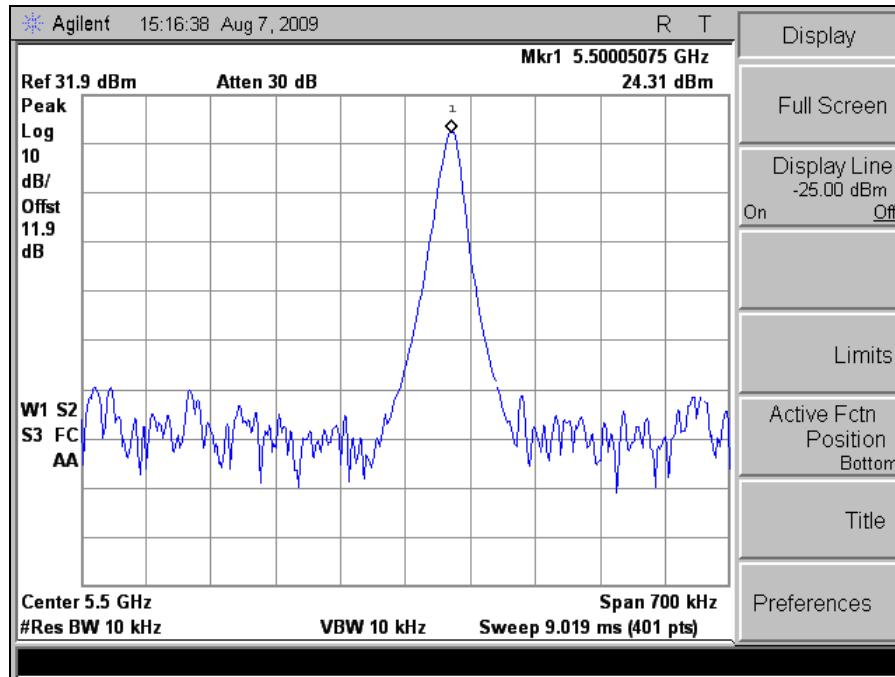

Plot 313. Freq. Stability, Port 2, 5500 MHz @+60C Low Volt.

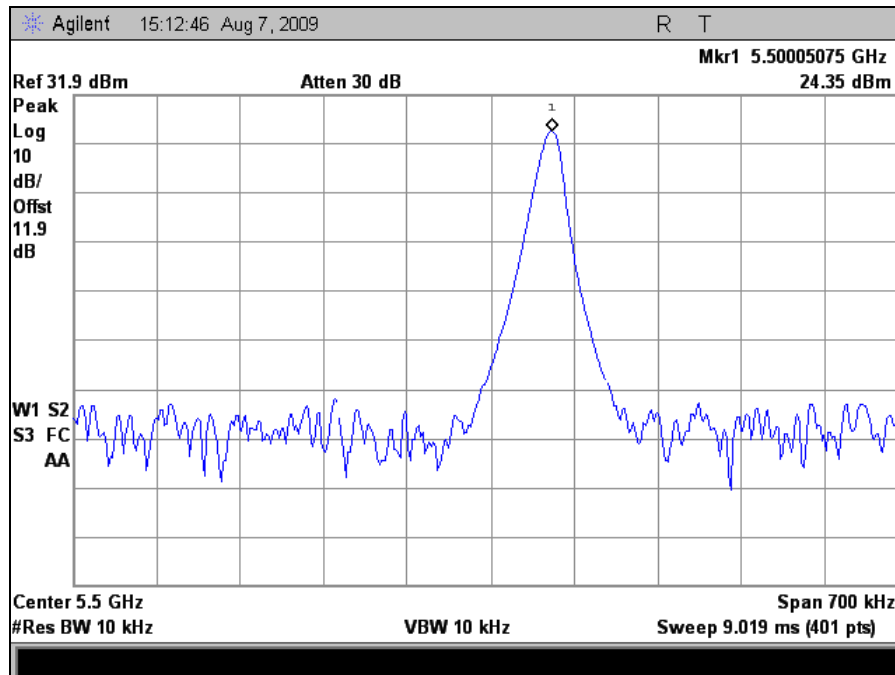

Plot 314. Freq. Stability, Port 2, 5500 MHz @+60C High Volt.

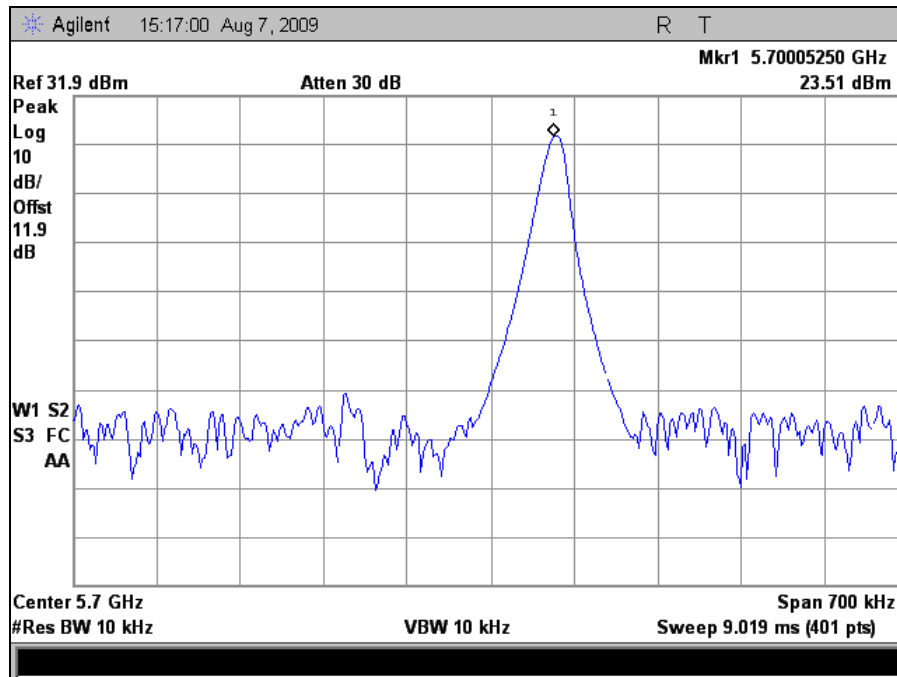

Plot 315. Freq. Stability, Port 2, 5700 MHz @+60C Low Volt.

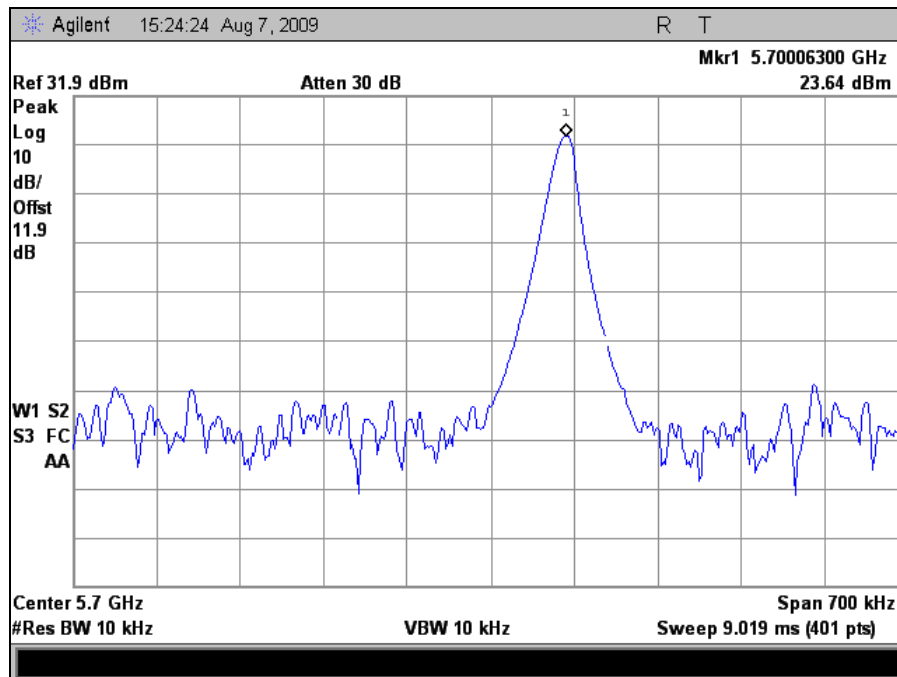

Plot 316. Freq. Stability, Port 2, 5700 MHz @+60C High Volt.

Frequency Stability, Port 3

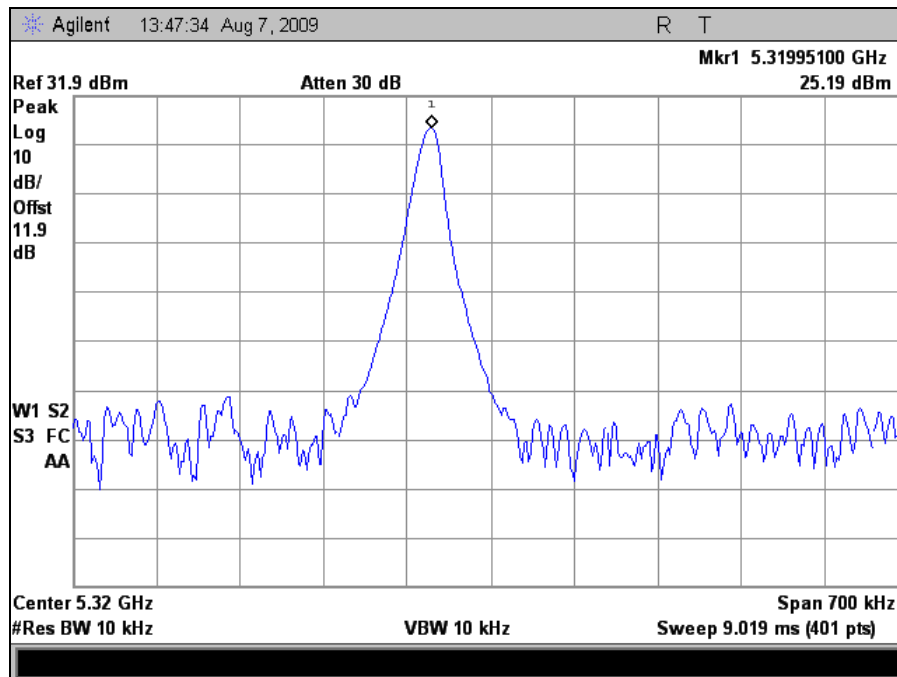

Plot 317. Freq. Stability, Port 3, 5320 MHz @ -40C Low Volt.

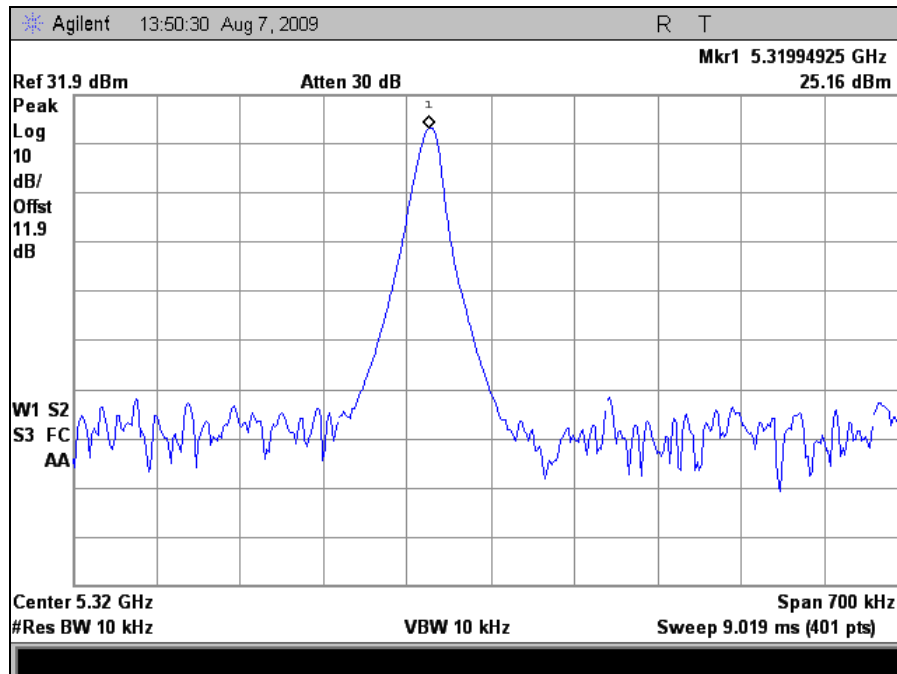

Plot 318. Freq. Stability, Port 3, 5320 MHz @ -40C High Volt.

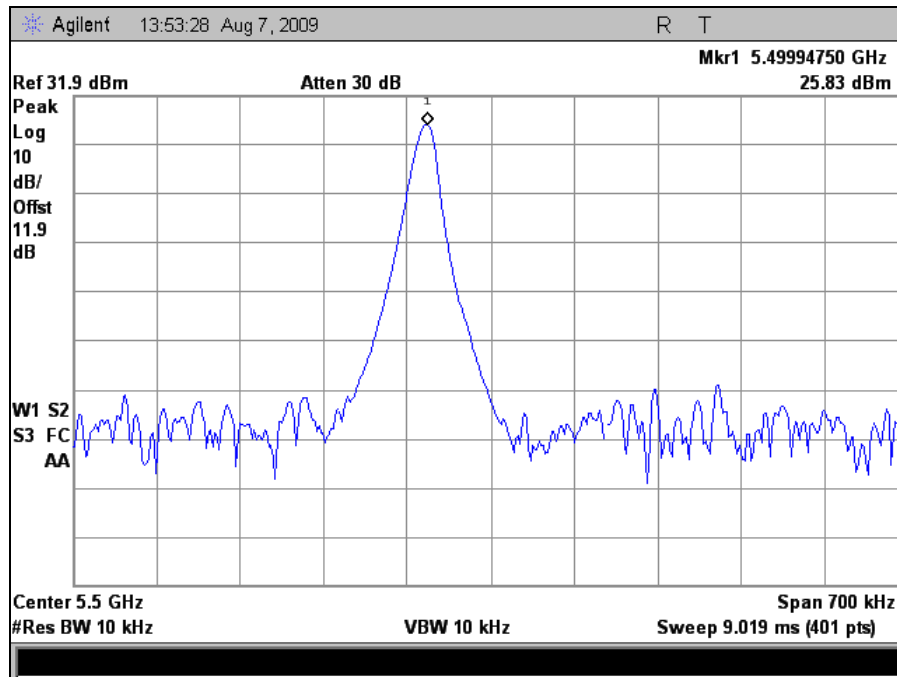

Plot 319. Freq. Stability, Port 3, 5500 MHz @-40C Low Volt.

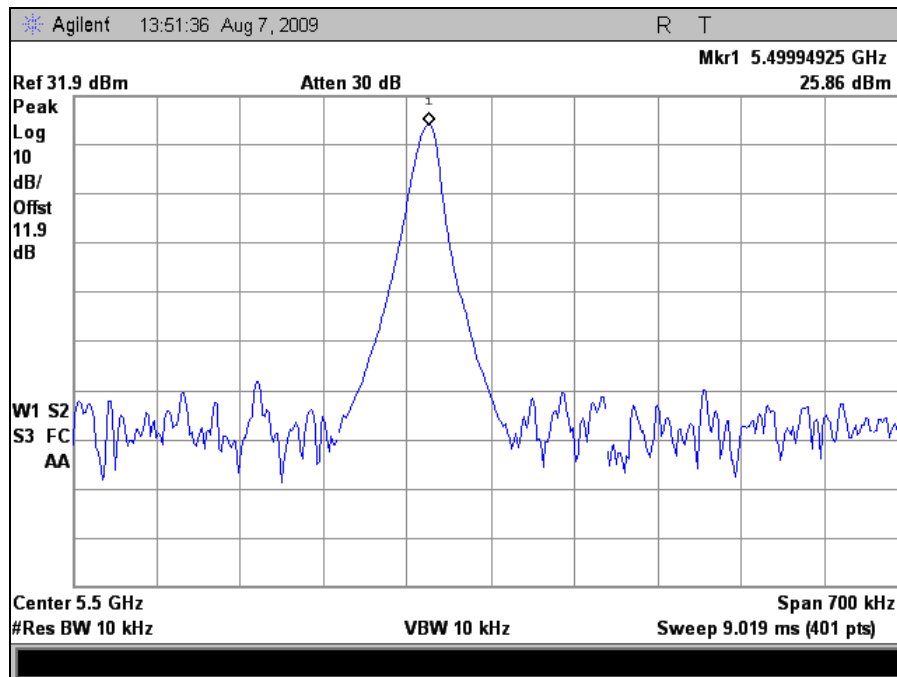

Plot 320. Freq. Stability, Port 3, 5500 MHz @-40C High Volt.

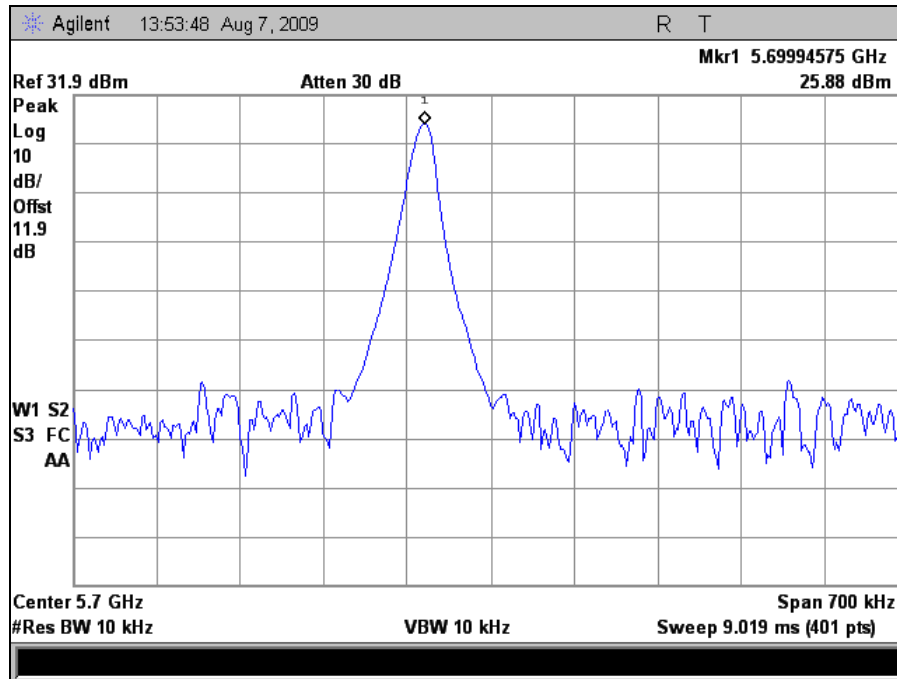

Plot 321. Freq. Stability, Port 3, 5700 MHz @-40C Low Volt.

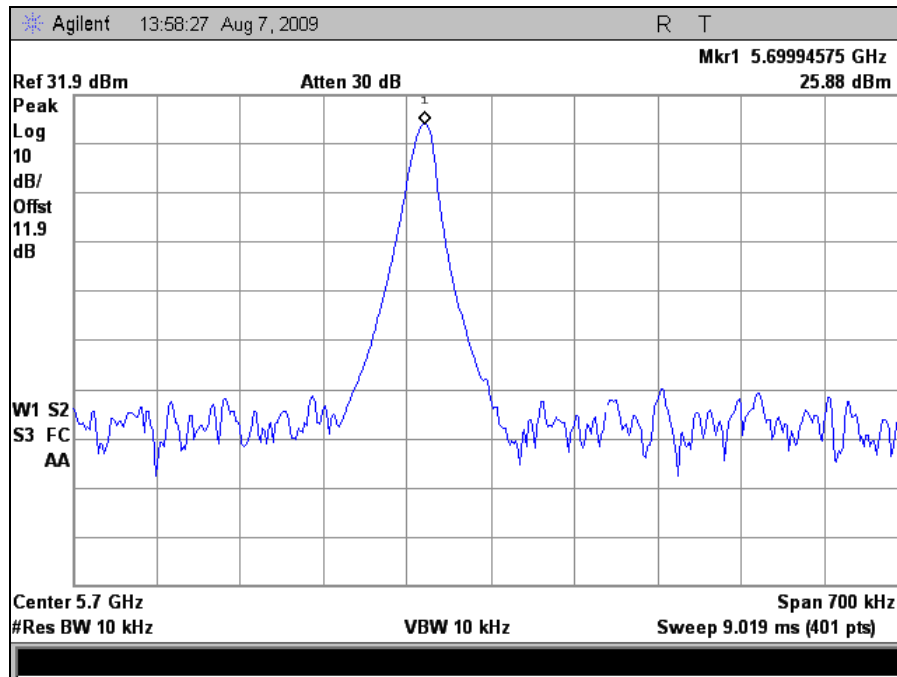

Plot 322. Freq. Stability, Port 3, 5700 MHz @-40C High Volt.

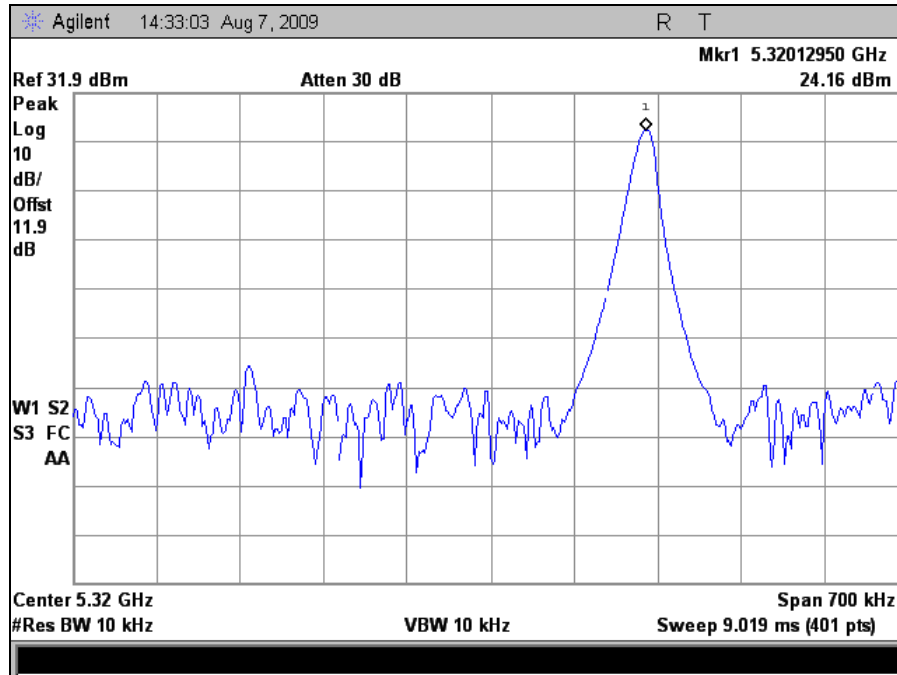

Plot 323. Freq. Stability, Port 3, 5320 MHz @+60C Low Volt.

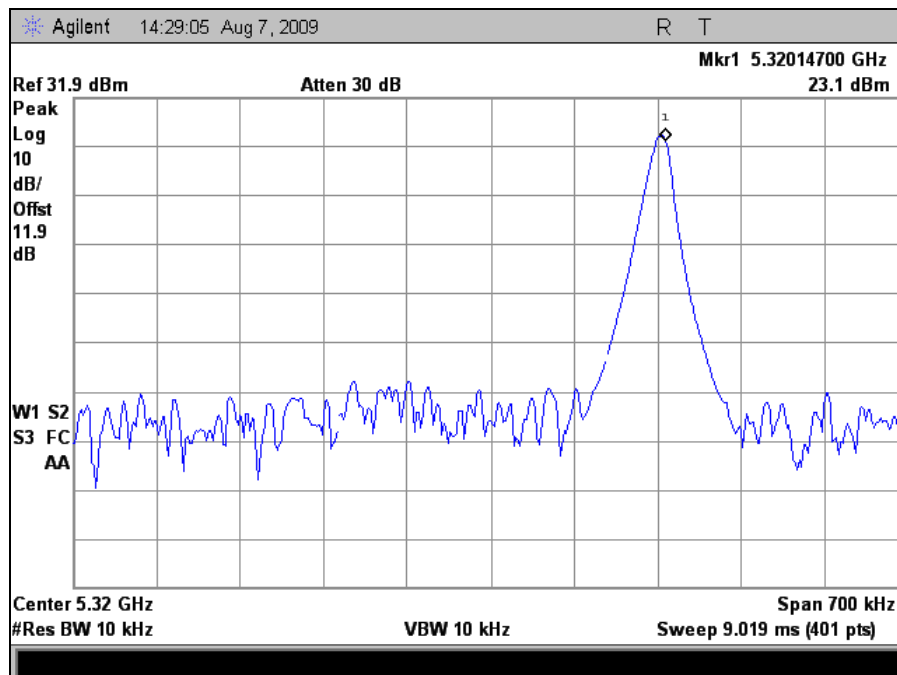

Plot 324. Freq. Stability, Port 3, 5320 MHz @+60C High Volt.

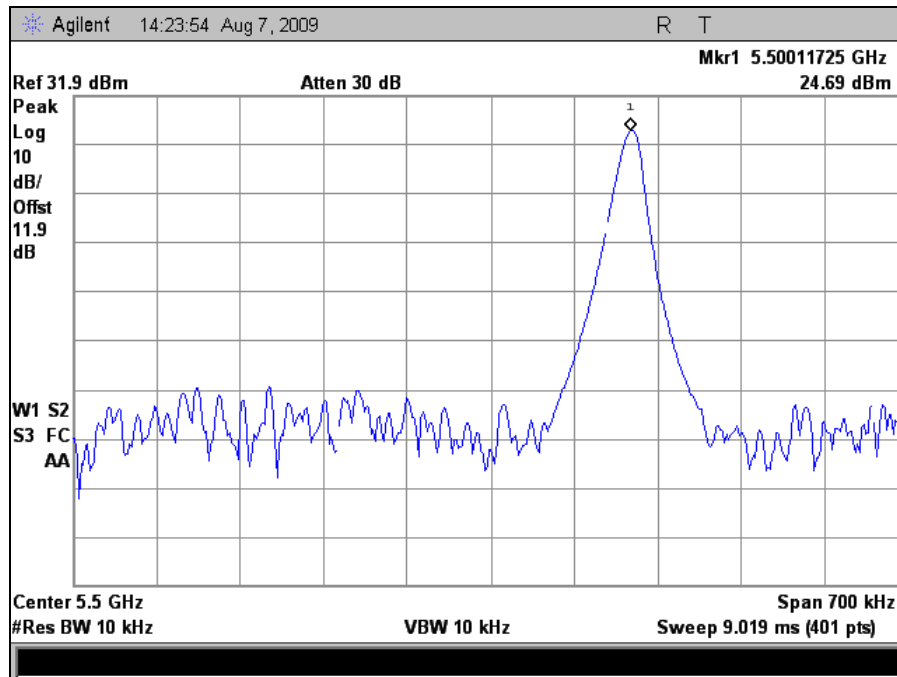

Plot 325. Freq. Stability, Port 3, 5500 MHz @+60C Low Volt.

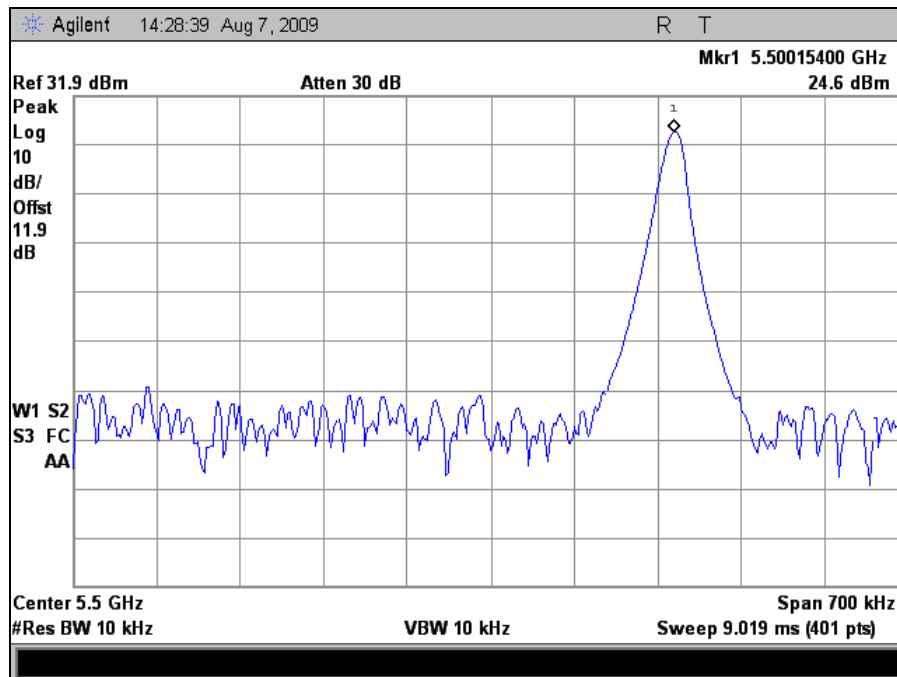

Plot 326. Freq. Stability, Port 3, 5500 MHz @+60C High Volt.

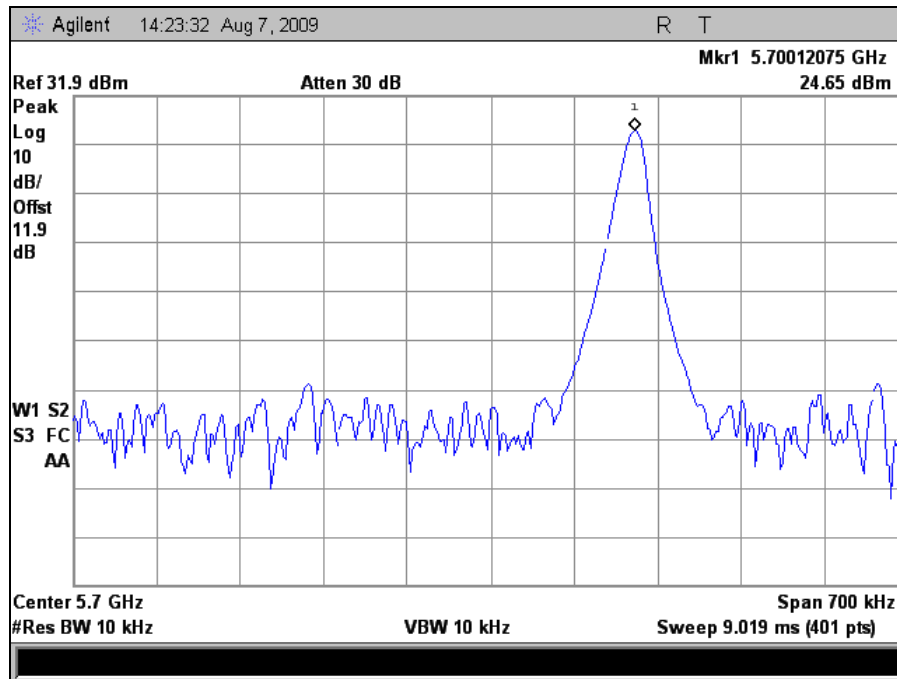

Plot 327. Freq. Stability, Port 3, 5700 MHz @+60C Low Volt.

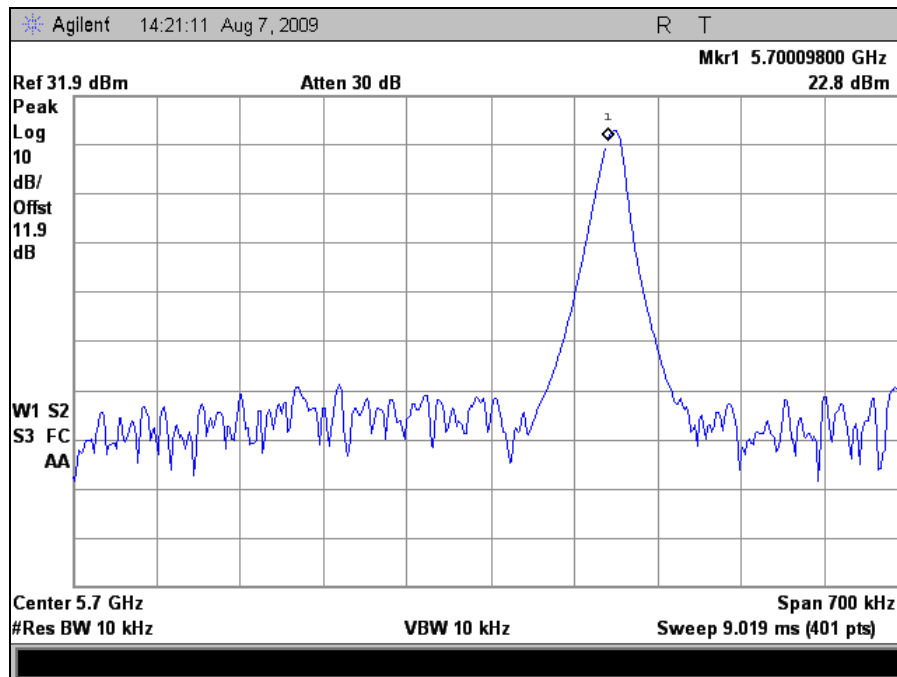

Plot 328. Freq. Stability, Port 3, 5700 MHz @+60C High Volt.

Electromagnetic Compatibility Criteria for Intentional Radiators

RSS-GEN Receiver Spurious Emissions

Test Requirement: The following receiver spurious emission limits shall be complied with:

- a) If a radiated measurement is made, all spurious emissions shall comply with the limits of Table 78.

Spurious Frequency (MHz)	Field Strength (microvolt/m at 3 metres)
30-88	100
88-216	150
216-960	200
Above 960	500

Table 78. Spurious Emission Limits for Receivers

- b) If a conducted measurement is made, no spurious output signals appearing at the antenna terminals shall exceed 2 nanowatts per any 4 kHz spurious frequency in the band 30-1000 MHz, or 5 nanowatts above 1 GHz.

Test Procedure: The receiver spurious emissions were tested in compliance with the limits of Table 12. The testing was performed conducted.

Test Results: The EUT was compliant with the Receiver Spurious Emission limits of this requirement.

Test Engineer(s): Anderson Soungpanya

Test Date(s): 09/11/09

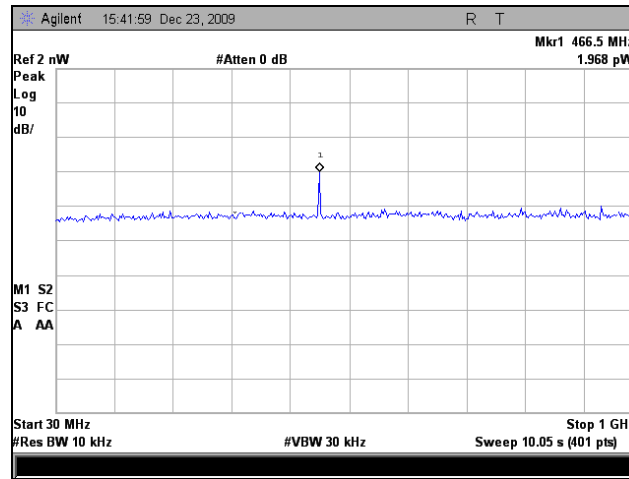

Plot 329. Conducted Receiver Spurious Emissions, Port 1, 30 MHz – 1 GHz

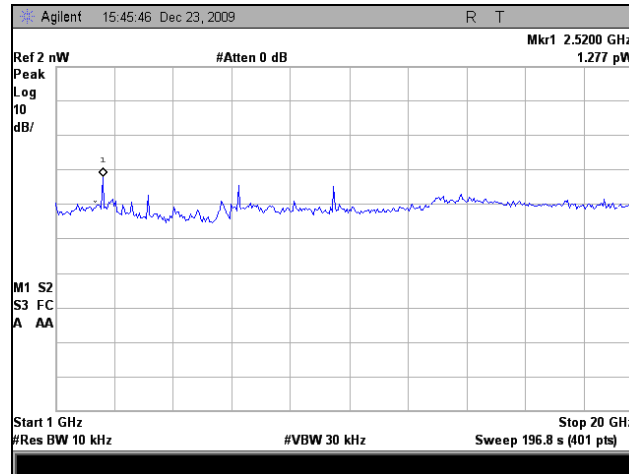

Plot 330. Conducted Receiver Spurious Emissions, Port 1, 1 GHz – 20 GHz

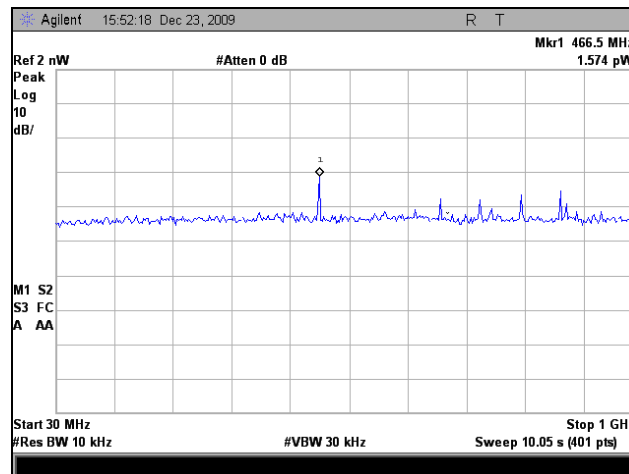

Plot 331. Conducted Receiver Spurious Emissions, Port 2, 30 MHz – 1 GHz

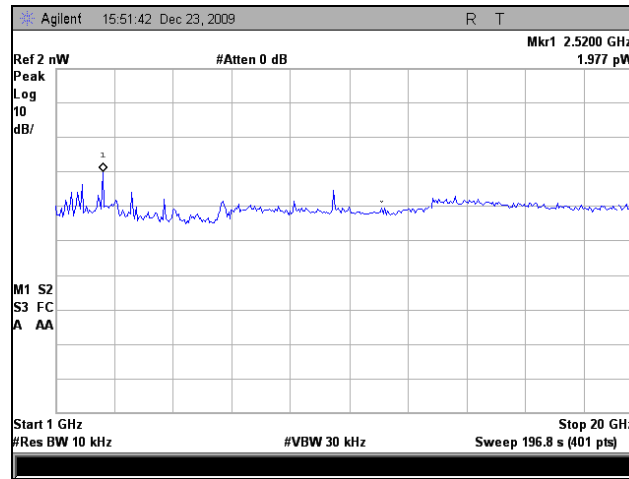

Plot 332. Conducted Receiver Spurious Emissions, Port 2, 1 GHz – 20 GHz

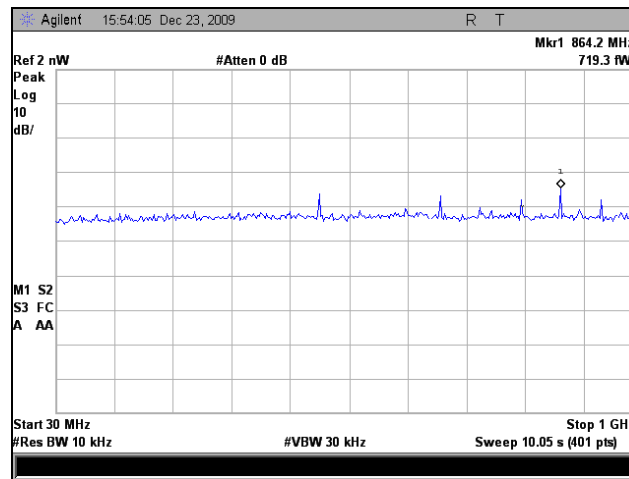

Plot 333. Conducted Receiver Spurious Emissions, Port 3, 30 MHz – 1 GHz

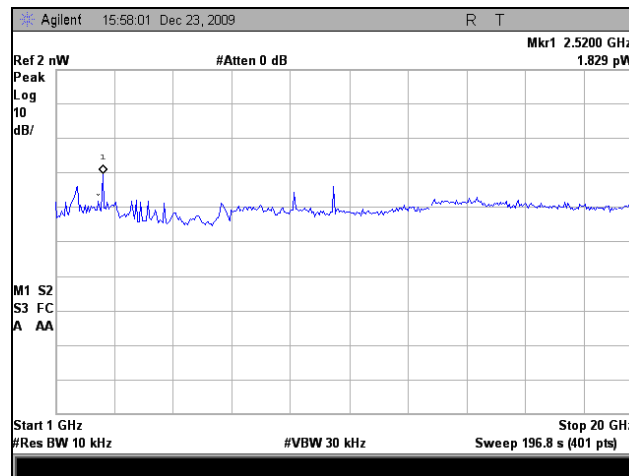

Plot 334. Conducted Receiver Spurious Emissions, Port 3, 1 GHz – 20 GHz

V. DFS Requirements and Radar Waveform Description & Calibration

A. DFS Requirements

DFS Detection Thresholds for Master or Client Devices Incorporating DFS

Maximum Transmit Power	Value
≥ 200 milliwatt	-64 dBm
< 200 milliwatt	-62 dBm

Note 1: This is the level at the input of the receiver assuming a 0 dBi receive antenna
Note 2: Throughout these test procedures an additional 1 dB has been added to the amplitude of the test transmission waveforms to account for variations in measurement equipment. This will ensure that the test signal is at or above the detection threshold level to trigger a DFS response.

DFS Response Requirement Values

Parameter	Value
<i>Non-occupancy period</i>	Minimum 30 minutes
<i>Channel Availability Check Time</i>	60 seconds
<i>Channel Move Time</i>	10 seconds See Note 1
<i>Channel Closing Transmission Time</i>	200 milliseconds + an aggregate of 60 milliseconds over remaining 10 second period. See Notes 1 and 2
<i>U-NII Detection Bandwidth</i>	Minimum 80% of the 99% power bandwidth. See Note 3.

Note 1: The instant that the *Channel Move Time* and the *Channel Closing Transmission Time* begins is as follows:

- For the Short pulse radar Test Signals this instant is the end of the *Burst*.
- For the Frequency Hopping radar Test Signal, this instant is the end of the last radar *Burst* generated.
- For the Long Pulse radar Test Signal this instant is the end of the 12 second period defining the radar transmission.

Note 2: The *Channel Closing Transmission Time* is comprised of 200 milliseconds starting at the beginning of the *Channel Move Time* plus any additional intermittent control signals required facilitating *Channel* changes (an aggregate of 60 milliseconds) during the remainder of the 10 second period. The aggregate duration of control signals will not count quiet periods in between transmissions.

Note 3: During the *U-NII Detection Bandwidth* detection test, radar type 1 is used and for each frequency step the minimum percentage of detection is 90%. Measurements are performed with no data traffic.

B. Radar Test Waveforms

This section provides the parameters for required test waveforms, minimum percentage of successful detections, and the minimum number of trials that must be used for determining DFS conformance. Step intervals of 0.1 microsecond for Pulse Width, 1 microsecond for PRI, 1 MHz for chirp width and 1 for the number of pulses will be utilized for the random determination of specific test waveforms.

Short Pulse Radar Test Waveforms

Radar Type	Pulse Width (μsec)	PRI (μsec)	Number of Pulses	Minimum Percentage of Successful Detection	Minimum Trials
1	1	1428	18	60%	30
2	1-5	150-230	23-29	60%	30
3	6-10	200-500	16-18	60%	30
4	11-20	200-500	12-16	60%	30
Aggregate (Radar Types 1-4)				80%	120

A minimum of 30 unique waveforms are required for each of the short pulse radar types 2 through 4. For short pulse radar type 1, the same waveform is used a minimum of 30 times. If more than 30 waveforms are used for short pulse radar types 2 through 4, then each additional waveform must also be unique and not repeated from the previous waveforms. The aggregate is the average of the percentage of successful detections of short pulse radar types 1-4.

Long Pulse Radar Test Waveform

Radar Type	Pulse Width (μsec)	Chirp Width (MHz)	PRI (μsec)	Number of Pulses per Bursts	Number of Bursts	Minimum Percentage of Successful Detection	Minimum Trials
5	50-100	5-20	1000-2000	1-3	8-20	80%	30

The parameters for this waveform are randomly chosen. Thirty unique waveforms are required for the Long Pulse radar test signal. If more than 30 waveforms are used for the Long Pulse radar test signal, then each additional waveform must also be unique and not repeated from the previous waveforms.

Each waveform is defined as follows:

- 1) The transmission period for the Long Pulse Radar test signal is 12 seconds.
- 2) There are a total of 8 to 20 Bursts in the 12 second period, with the number of Bursts being randomly chosen. This number is Burst_Count.
- 3) Each Burst consists of 1 to 3 pulses, with the number of pulses being randomly chosen. Each Burst within the 12 second sequence may have a different number of pulses.
- 4) The pulse width is between 50 and 100 microseconds, with the pulse width being randomly chosen. Each pulse within a Burst will have the same pulse width. Pulses in different Bursts may have different pulse widths.
- 5) Each pulse has a linear FM chirp between 5 and 20 MHz, with the chirp width being randomly chosen. Each pulse within a Burst will have the same chirp width. Pulses in different Bursts may have different chirp widths. The chirp is centered on the pulse. For example, with radar frequency of 5300 MHz and a 20 MHz chirped signal, the chirp starts at 5290 MHz and ends at 5310 MHz.
- 6) If more than one pulse is present in a Burst, the time between the pulses will be between 1000 and 2000 microseconds, with the time being randomly chosen. If three pulses are present in a Burst, the time between the first and second pulses is chosen independently of the time between the second and third pulses.
- 7) The 12 second transmission period is divided into even intervals. The number of intervals is equal to Burst_Count. Each interval is of length $(12,000,000 / \text{Burst_Count})$ microseconds. Each interval contains one Burst. The start time for the Burst, relative to the beginning of the interval, is between 1 and $[(12,000,000 / \text{Burst_Count}) - (\text{Total Burst Length}) + (\text{One Random PRI Interval})]$ microseconds, with the start time being randomly chosen. The step interval for the start time is 1 microsecond. The start time for each Burst is chosen independently.

A representative example of a Long Pulse radar test waveform:

- 1) The total test signal length is 12 seconds.
- 2) 8 Bursts are randomly generated for the Burst_Count.
- 3) Burst 1 has 2 randomly generated pulses.
- 4) The pulse width (for both pulses) is randomly selected to be 75 microseconds.
- 5) The PRI is randomly selected to be at 1213 microseconds.
- 6) Bursts 2 through 8 are generated using steps 3 – 5.
- 7) Each Burst is contained in even intervals of 1,500,000 microseconds. The starting location for Pulse 1, Burst 1 is randomly generated (1 to 1,500,000 minus the total Burst 1 length + 1 random PRI interval) at the 325,001 microsecond step. Bursts 2 through 8 randomly fall in successive 1,500,000 microsecond intervals (i.e. Burst 2 falls in the 1,500,001 – 3,000,000 microsecond range).

Graphical Representation of a Long Pulse radar Test Waveform

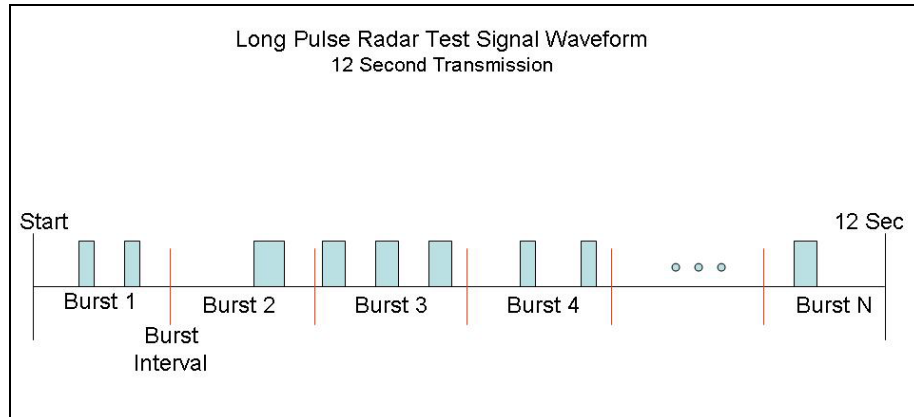

Figure 5. Long Pulse Radar Test Signal Waveform

Frequency Hopping Radar Test Waveform

Radar Type	Pulse Width (μsec)	PRI (μsec)	Pulses per Hop	Hopping Rate (kHz)	Hopping Sequence Length (msec)	Minimum Percentage of Successful Detection	Minimum Trials
6	1	333	9	.333	300	70%	30

For the Frequency Hopping Radar Type, the same *Burst* parameters are used for each waveform. The hopping sequence is different for each waveform and a 100-length segment is selected from the hopping sequence defined by the following algorithm:

The first frequency in a hopping sequence is selected randomly from the group of 475 integer frequencies from 5250 – 5724 MHz. Next, the frequency that was just chosen is removed from the group and a frequency is randomly selected from the remaining 474 frequencies in the group. This process continues until all 475 frequencies are chosen for the set. For selection of a random frequency, the frequencies remaining within the group are always treated as equally likely.

C. Radar Waveform Calibration

The following equipment setup was used to calibrate the conducted Radar Waveform. A spectrum analyzer was used to establish the test signal level for each radar type. During this process there were no transmissions by either the Master or Client Device. The spectrum analyzer was switched to the zero span (Time Domain) mode at the frequency of the Radar Waveform generator. Peak detection was utilized. The spectrum analyzer's resolution bandwidth (RBW) was set to 3 MHz and the video bandwidth (VBW) was set to 3 MHz. The calibration setup is diagrammed in Figure 6, and the radar test signal generator is shown in Figure 6.

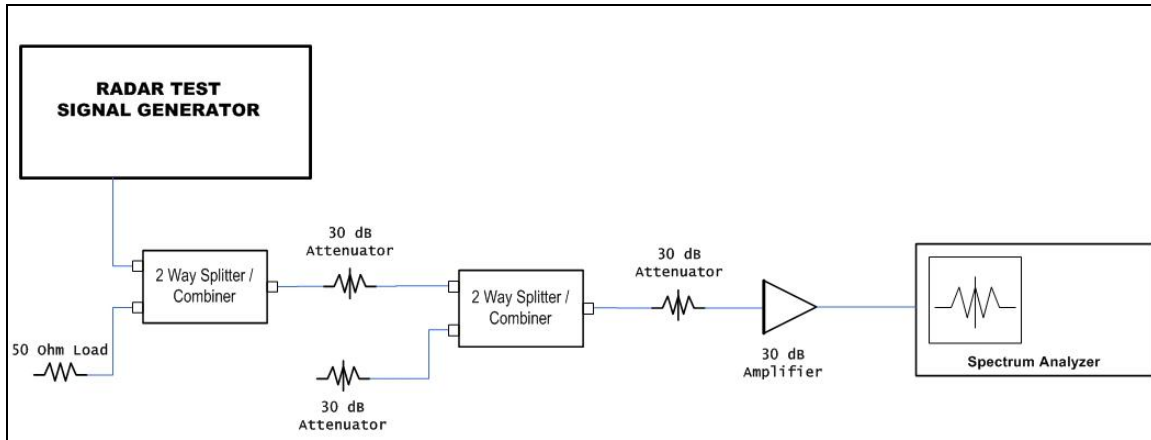
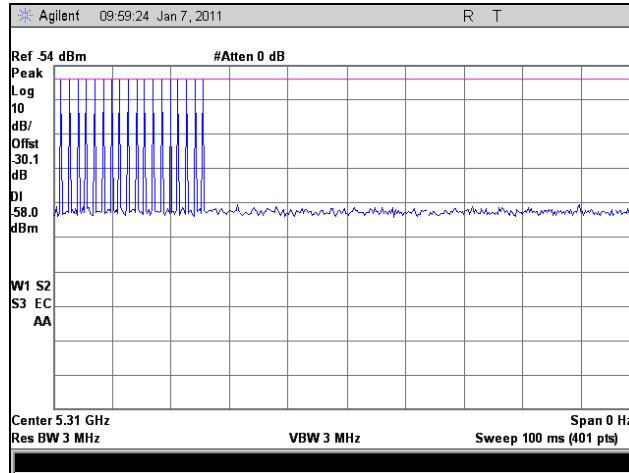
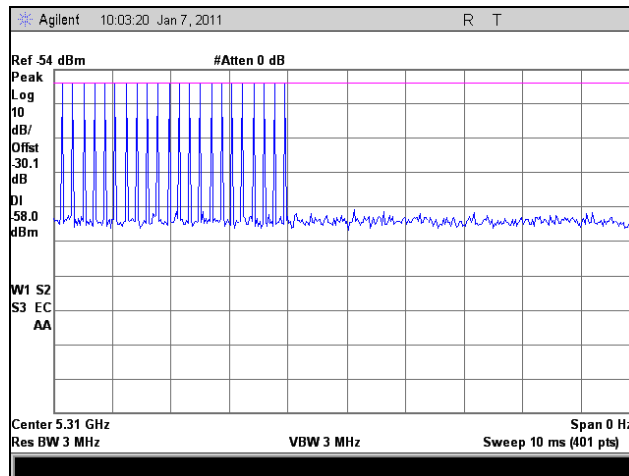

Figure 6. DFS Radar Waveform Calibration Setup

Radar Waveform Calibration, 5310 MHz (Probabilities and Bandwidth only)



Radar Type 1 Calibration, 5310 MHz



Radar Type 2 Calibration, 5310 MHz

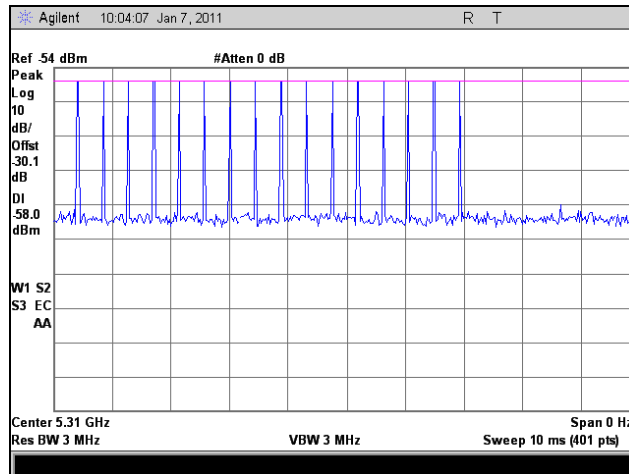

Radar Type 3 Calibration, 5310 MHz

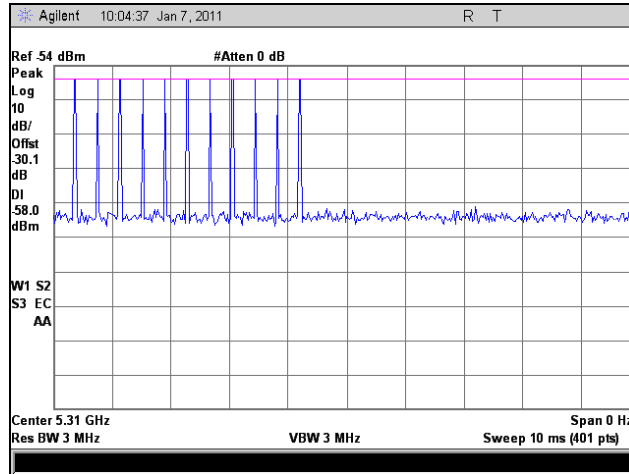

Radar Type 4 Calibration, 5310 MHz

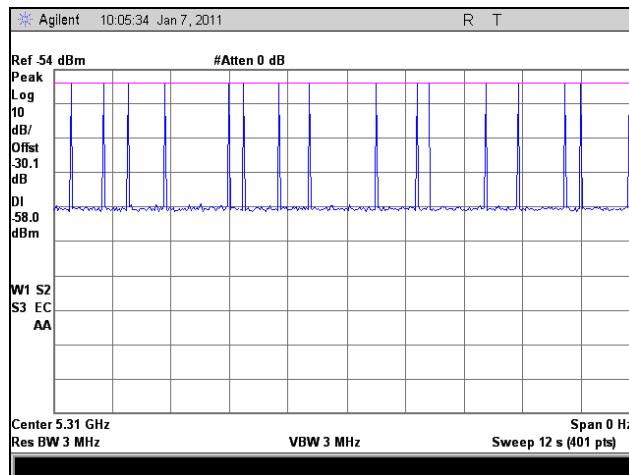

Radar Type 5 Calibration, 5310 MHz

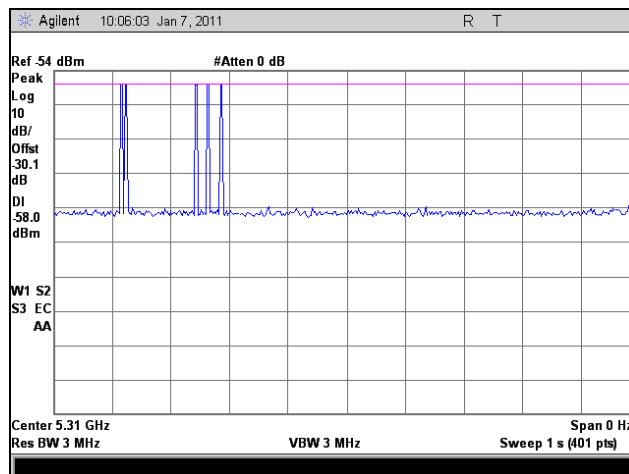

Radar Type 6 Calibration, 5310 MHz

Radar Waveform Calibration, 5320 MHz (Probabilities only)

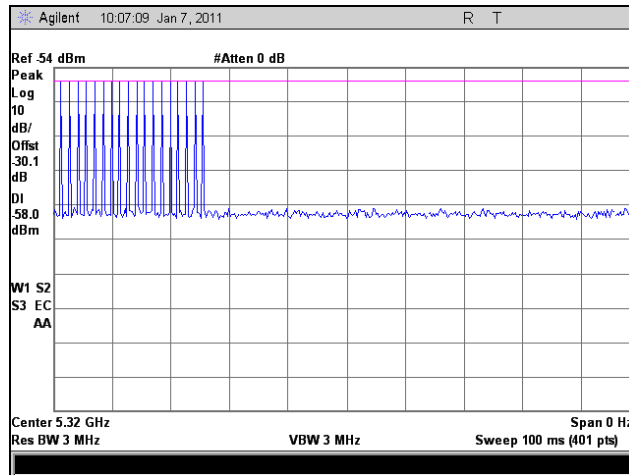

Radar Type 1 Calibration, 5320 MHz

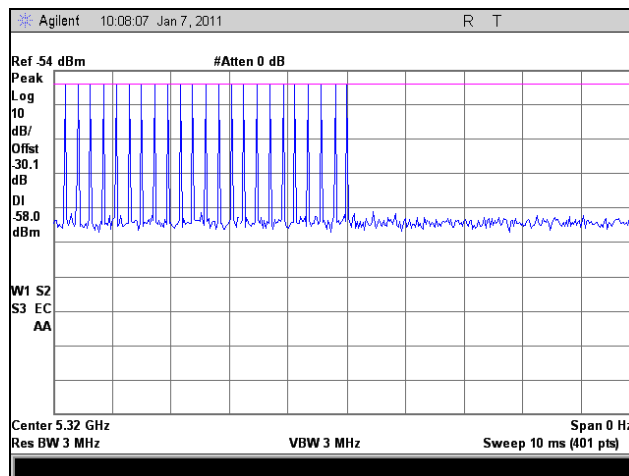

Radar Type 2 Calibration, 5320 MHz

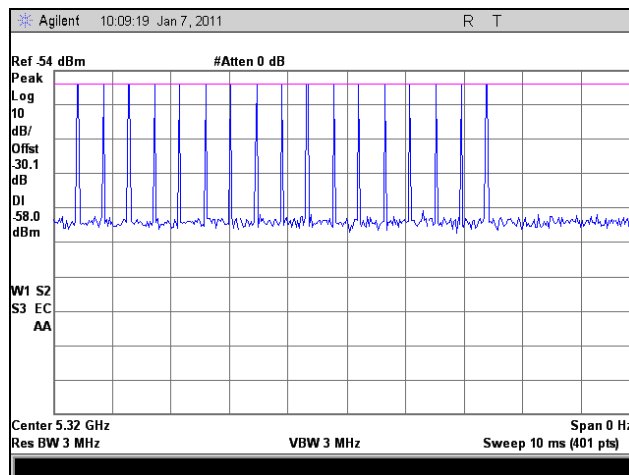

Radar Type 3 Calibration, 5320 MHz

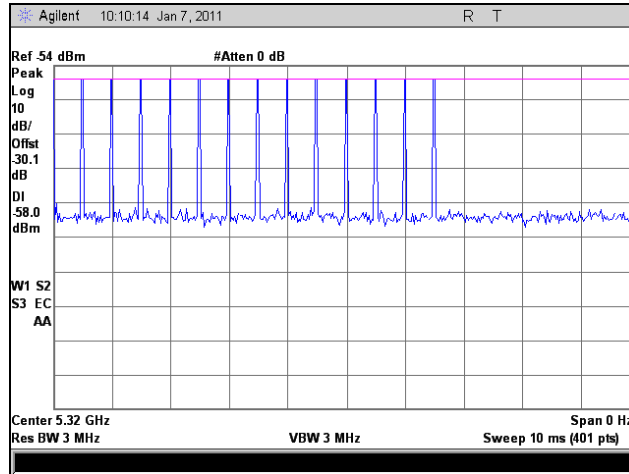

Radar Type 4 Calibration, 5320 MHz

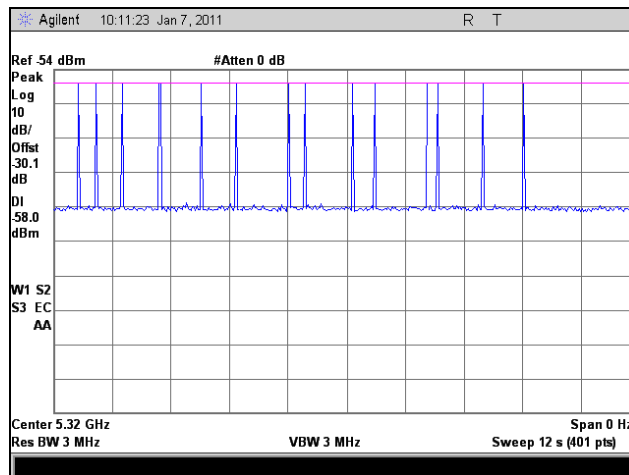

Radar Type 5 Calibration, 5320 MHz

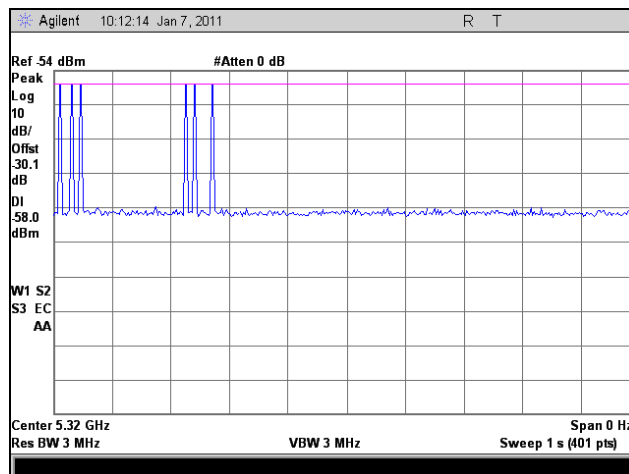

Radar Type 6 Calibration, 5320 MHz

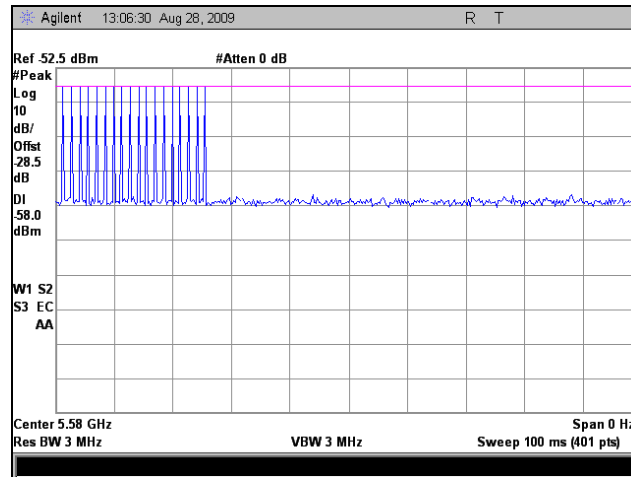

Calibration Plot, Bin 1, 5580 MHz (used for CACT, Bandwidth, Non Occupancy, Close Time & Move Time)

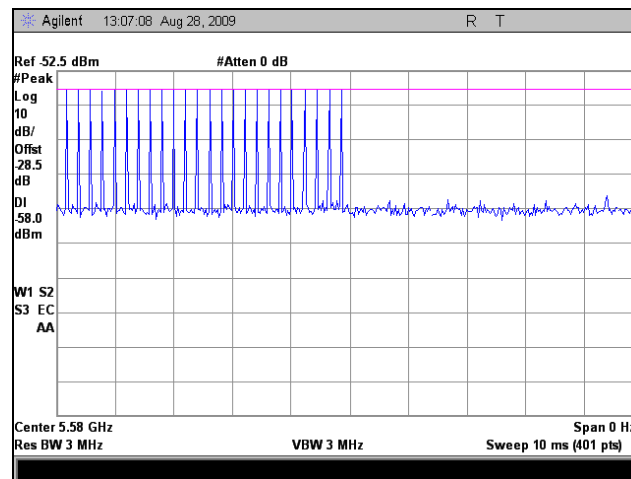

Calibration Plot, Bin 2, 5580 MHz (used for CACT, Bandwidth, Non Occupancy, Close Time & Move Time)

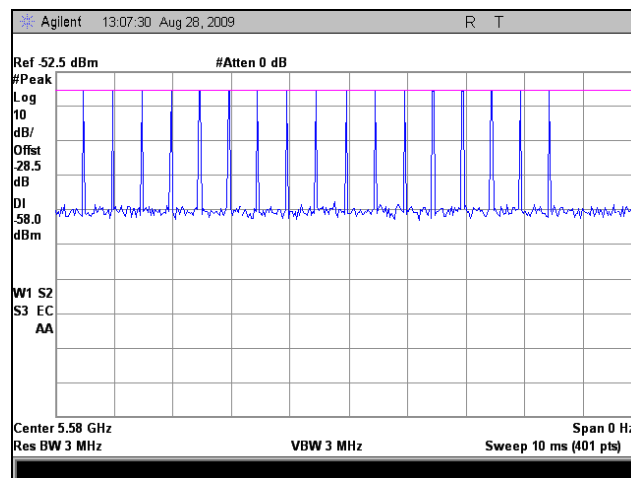

Calibration Plot, Bin 3, 5580 MHz (used for CACT, Bandwidth, Non Occupancy, Close Time & Move Time)

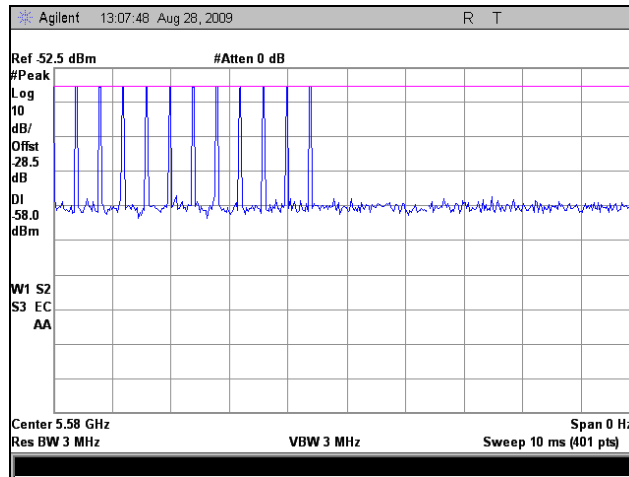

Calibration Plot, Bin 4, 5580 MHz (used for CACT, Bandwidth, Non Occupancy, Close Time & Move Time)

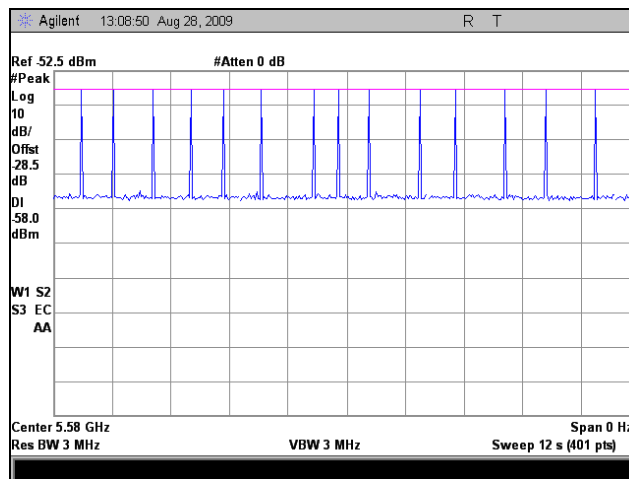

Calibration Plot, Bin 5, 5580 MHz (used for CACT, Bandwidth, Non Occupancy, Close Time & Move Time)

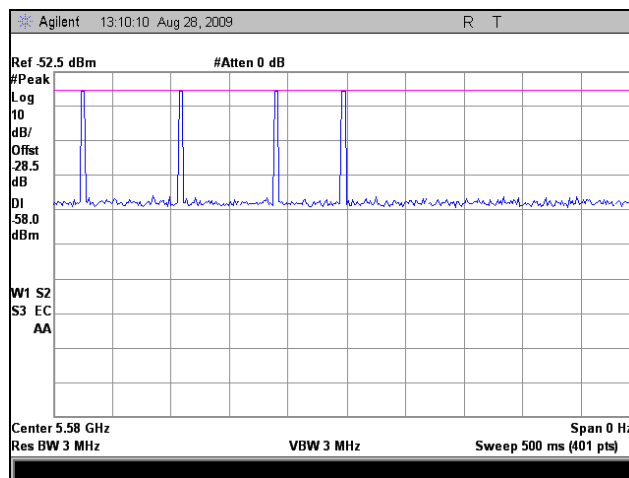

Calibration Plot, Bin 6, 5580 MHz (used for CACT, Bandwidth Non Occupancy, Close Time & Move Time)

VI. DFS Test Procedure and Test Results

A. DFS Test Setup

1. A spectrum analyzer is used as a monitor to verify that the Unit Under Test (UUT) has vacated the Channel within the Channel Closing Transmission Time and Channel Move Time, and does not transmit on a Channel during the Non-Occupancy Period after the detection and subsequent Channel move. It is also used to monitor UUT transmissions during the Channel Availability Check Time.
2. The test setup, which consists of test equipment and equipment under test (EUT), is diagrammed in Figure 7 and pictured in Figure 7. Test Setup Diagram.

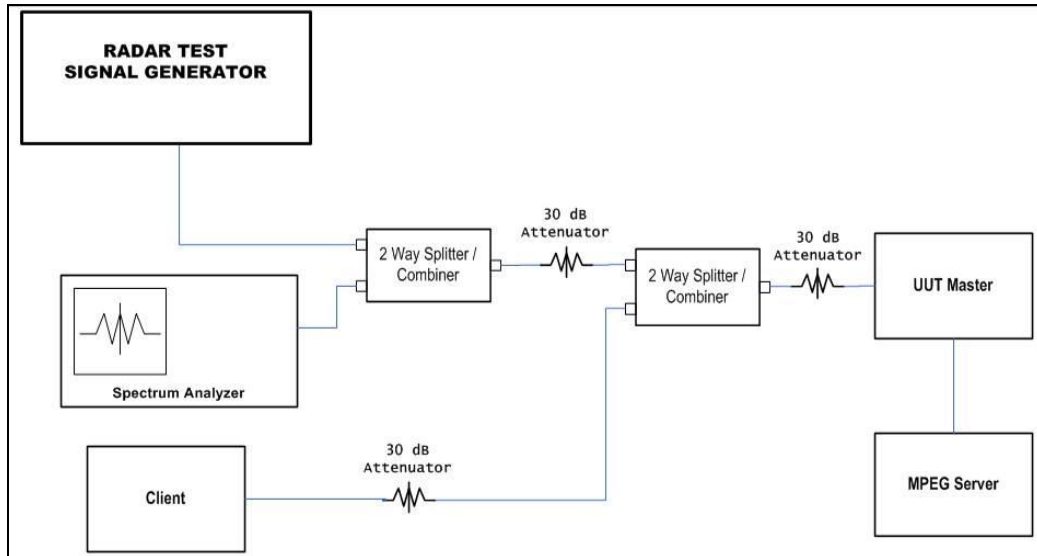

Figure 7. Test Setup Diagram

B. Description of Master Device

1. Operating Frequency Range – 5500-5700 MHz
2. Modes of Operation – 802.11a/802.11n
3. Highest and Lowest EIRP – Highest: 29.98 dBm; Lowest: 21.60 dBm
4. List all antennas and associated gains –
 - MA-WA55-MIMO.pdf
Gain is 19

 - MA-WD55-MIMOFT16.pdf
Gain is 16

 - MA-WO55-9NHFT3.pdf
Gain is 9

 - C812-510012-A.pdf
Gain is 5
5. List output power ranges – 11.83dBm - 20.21 dBm
6. List antenna impedance – 50 ohms
7. Antenna gain verification - Use antenna data sheet
8. State test file that is transmitted – 6 and ½ Magic Hours
9. Time for master to complete its power-on-cycle – 78 seconds

C. UNII Detection Bandwidth

Test Requirement(s): § 15.407 A minimum 80% detection rate is required across an EUT's 99% bandwidth.

Test Procedure: All UNII channels for this device have two channel bandwidths. Therefore, DFS testing was done at 20 MHz bandwidth at 5580 MHz and 40 MHz bandwidth at 5310 MHz.

A single burst of the short pulse radar type 1 is produced at 5580 and 5310 MHz, at the -63dBm test level. The UUT is set up as a standalone device (no associated client, and no data traffic).

A single radar burst is generated for a minimum of 10 trials, and the response of the UUT is recorded. The UUT must detect the radar waveform 90% or more of the time.

The radar frequency is increased in 1 MHz steps, repeating the above test sequence, until the detection rate falls below 90%. The highest frequency at which detection is greater than or equal to 90% is denoted F_H .

The radar frequency is decreased in 1 MHz steps, repeating the above test sequence, until the detection rate falls below 90%. The lowest frequency at which detection is greater than or equal to 90% is denoted F_L .

The U-NII Detection Bandwidth is calculated as follows:

$$\text{U-NII Detection Bandwidth} = F_H - F_L$$

Test Engineer: Anderson Soungpanya

Test Date: 08/26/09 – 09/02/09

UNII Detection Bandwidth – Test Results

EUT Frequency- 5580MHz											
Radar Frequency (MHz)	DFS Detection Trials (1=Detection, 0= No Detection)										Detection Rate (%)
	1	2	3	4	5	6	7	8	9	10	
5566	1	1	1	1	0	1	0	1	0	0	60
5567(FL)	1	1	1	1	1	1	1	1	1	0	90
5568	1	1	1	1	1	1	1	1	1	1	100
5569	1	1	1	1	1	1	1	1	1	1	100
5570	1	1	1	1	1	1	1	1	1	1	100
5571	1	1	1	1	1	1	1	1	1	1	100
5572	1	1	1	1	1	1	1	1	1	1	100
5573	1	1	1	1	1	1	1	1	1	1	100
5574	1	1	1	1	1	1	1	1	1	1	100
5575	1	1	1	1	1	1	1	1	1	1	100
5576	1	1	1	1	1	1	1	1	1	1	100
5577	1	1	1	1	1	1	1	1	1	1	100
5578	1	1	1	1	1	1	1	1	1	1	100
5579	1	1	1	1	1	1	1	1	1	1	100
5580	1	1	1	1	1	1	1	1	1	1	100
5581	1	1	1	1	1	1	1	1	1	1	100
5582	1	1	1	1	1	1	1	1	1	1	100
5583	1	1	1	1	1	1	1	1	1	1	100
5584	1	1	1	1	1	1	1	1	1	1	100
5585	1	1	1	1	1	1	1	1	1	1	100
5586	1	1	1	1	1	1	1	1	1	1	100
5587	1	1	1	1	1	1	1	1	1	1	100
5588	1	1	1	1	1	1	1	1	1	1	100
5589	1	1	1	1	1	1	1	1	1	1	100
5590	1	1	1	1	1	1	1	1	1	1	100
5591	1	1	1	1	1	1	1	1	1	1	100
5592	1	1	1	1	1	1	1	1	1	1	100
5593	1	1	1	1	1	1	1	1	1	1	100
5594	1	1	1	1	1	0	1	1	1	1	90
5595 (FH)	1	1	1	1	1	1	1	0	1	1	90
5596	1	1	1	0	1	0	1	0	1	0	60
Overall Detection Percentage											89.42%
Detection Bandwidth = $f_h - f_l = 5595\text{MHz} - 5567\text{MHz} = 28\text{MHz}$											
EUT 99% Bandwidth = 17.6548 MHz											
OBW* 80% = 14.1238 MHz (Detection Bandwidth shall not be less than 14.1238MHz. Measured Detection Bandwidth is 28MHz.)											

Table 79. UNII Detection Bandwidth, Test Results, 5580 MHz, 802.11a

EUT Frequency- 5980MHz 40MHz BW											
DFS Detection Trials (1=Detection, 0= No Detection)											
Radars Frequency (MHz)	1	2	3	4	5	6	7	8	9	10	Detection Rate (%)
5288	0	1	1	0	0	1	0	1	1	1	60
5289 (fL)	1	1	1	1	1	1	1	1	1	1	100
5290	1	1	1	1	1	1	1	1	1	1	100
5291	1	1	1	1	1	1	1	1	1	1	100
5292	1	1	1	1	1	1	1	1	1	1	100
5293	1	1	1	1	1	1	1	1	1	1	100
5294	1	1	1	1	1	1	1	1	1	1	100
5295	1	1	1	1	1	1	1	1	1	1	100
5296	1	1	1	1	1	1	1	1	1	1	100
5297	1	1	1	1	1	1	1	1	1	1	100
5298	1	1	1	1	1	1	1	1	1	1	100
5299	1	1	1	1	1	1	1	1	1	1	100
5300	1	1	1	1	1	1	1	1	1	1	100
5301	1	1	1	1	1	1	1	1	1	1	100
5302	1	1	1	1	1	1	1	1	1	1	100
5303	1	1	1	1	1	1	1	1	1	1	100
5304	1	1	1	1	1	1	1	1	1	1	100
5305	1	1	1	1	1	1	1	1	1	1	100
5306	1	1	1	1	1	1	1	1	1	1	100
5307	1	1	1	1	1	1	1	1	1	1	100
5308	1	1	1	1	1	1	1	1	1	1	100
5309	1	1	1	1	1	1	1	1	1	1	100
5310	1	1	1	1	1	1	1	1	1	1	100
5311	1	1	1	1	1	1	1	1	1	1	100
5312	1	1	1	1	1	1	1	1	1	1	100
5313	1	1	1	1	1	1	1	1	1	1	100
5314	1	1	1	1	1	1	1	1	1	1	100
5315	1	1	1	1	1	1	1	1	1	1	100
5316	1	1	1	1	1	1	1	1	1	1	100
5317	1	1	1	1	1	1	1	1	1	1	100
5318	1	1	1	1	1	1	1	1	1	1	100
5319	1	1	1	1	1	1	1	1	1	1	100
5320	1	1	1	1	1	1	1	1	1	1	100
5321	1	1	1	1	1	1	1	1	1	1	100
5322	1	1	1	1	1	1	1	1	1	1	100
5323	1	1	1	1	1	1	1	1	1	1	100
5324	1	1	1	1	1	1	1	1	1	1	100
5325	1	1	1	1	1	1	1	1	1	1	100
5326	1	1	1	1	1	1	1	1	1	1	100
5327	1	1	1	1	1	1	1	1	1	1	100
5328	1	1	1	1	1	1	1	1	1	1	100
5329	1	1	1	1	1	1	1	1	1	1	100
5330	1	1	1	1	1	1	1	1	1	1	100
5331 (fH)	1	1	1	1	1	1	1	1	1	1	100
5332	0	1	1	1	1	1	0	0	1	0	60
Overall Detection Percentage											86.23%
Detection Bandwidth = $f_h - f_l = 5331\text{MHz} - 5288\text{MHz} = 42\text{MHz}$											
EUT 99% Bandwidth = 36.2819 MHz											
OBW* 80% = 29.03 MHz (Detection Bandwidth Limit shall not be under 29.03MHz. Measured Detection Bandwidth is 42MHz.)											

Table 80. UNII Detection Bandwidth, Test Results,5310 MHz, 802.11n 40MHz

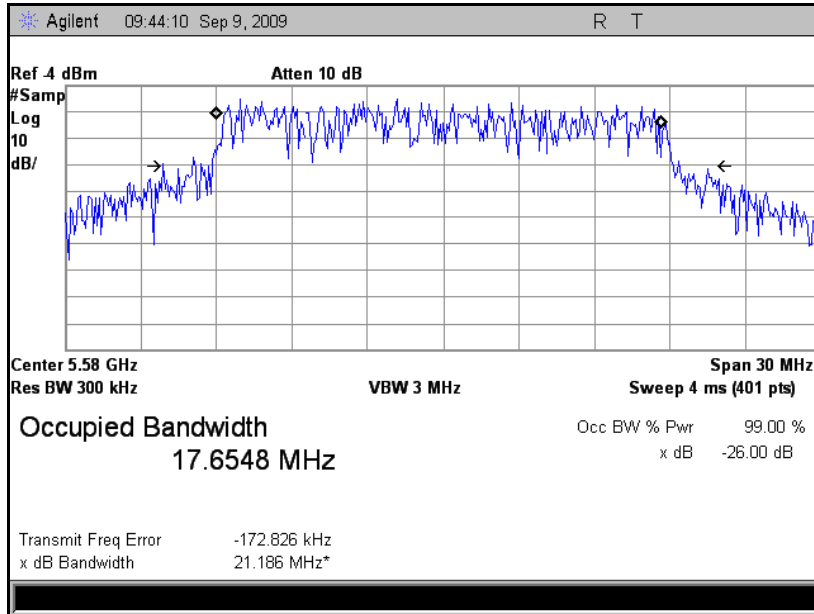

Plot 335. Occupied Bandwidth, 802.11a, 5580 MHz

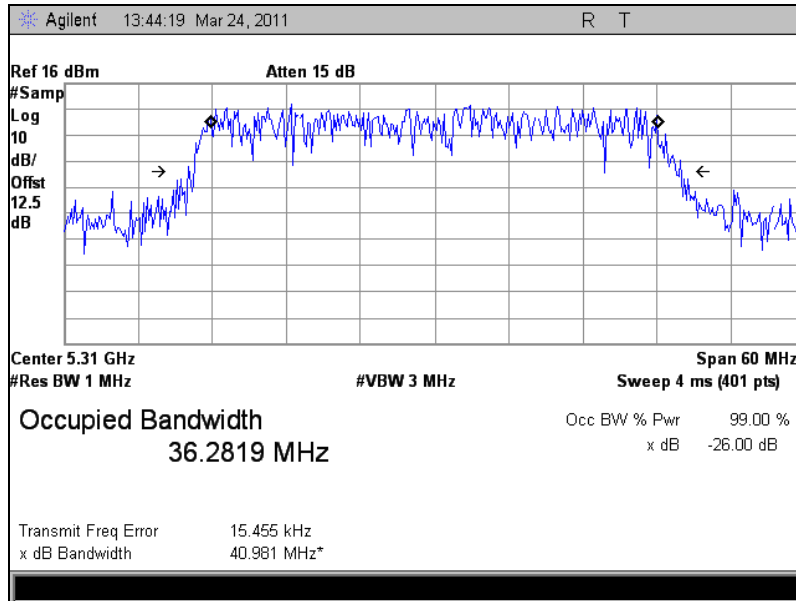

Plot 336. Occupied Bandwidth, 802.11n 40MHz, 5310 MHz

D. Initial Channel Availability Check Time

Test Requirements: § 15.407 The Initial Channel Availability Check Time tests that the UUT does not emit beacon, control, or data signals on the test channel until the power-up sequence has been completed and the U-NII device has checked for radar waveforms, for one minute, on the test channel. This test does not use any of the radar waveforms and only needs to be performed once.

The UUT should not make any transmissions over the test channel, for at least 1 minute after completion of its power-on cycle.

Test Procedure: The U-NII device is powered on and instructed to operate at 5580 MHz. At the same time the UUT is powered on, the spectrum analyzer is set to 5580MHz with a zero span and a 2.5 minute sweep time. The analyzer is triggered at the same time power is applied to the U-NII device.

Test Results: The initial power up time of the EUT is indicated by marker 1R on Plot 337. Initial beacon/data transmission is indicated by marker 1.

The Equipment complies with § 15.407 Initial Channel Availability Check Time.

Test Engineer: Anderson Soungpanya

Test Date: 08/26/09 – 09/02/09

E. Radar Burst at the Beginning of Channel Availability Check Time

Test Requirements: § 15.407 A Radar Burst at the Beginning of the Channel Availability Check Time tests that the UUT does not emit beacon, control, or data signals on the test Channel if it has detected a radar burst during that time period until the power-up sequence has been completed and the U-NII device checks for Radar Waveforms for one minute on the test Channel. The steps below define the procedure to verify successful radar detection on the selected Channel during a period equal to the Channel Availability Check Time and avoidance of operation on that Channel when a radar Burst with a level equal to the DFS Detection Threshold + 1 dB (-63dBm) occurs at the beginning of the Channel Availability Check Time.

Test Procedure: The UUT is powered on at T0. T1 denotes the instant when the UUT has completed its power-up sequence. The Channel Availability Check Time commences at instant T1 and will end no sooner than T1 + 60 seconds.

A single Burst of short pulse radar type 1, at -63 dBm, will commence within a 6 second window starting at T1.

Visual indication of the UUT of successful detection of the radar Burst will be recorded and reported. Observation of transmission at 5580MHz will continue for 2.5 minutes after the radar Burst has been generated.

Verify that during the 2.5 minute measurement window, no UUT transmissions occur at 5580MHz.

Test Results Plot 338 below indicates that there were no UUT transmissions during the 2.5 minute measurement window. Marker 1R indicates completion of the power-on cycle. Marker 1 indicates the end of the 60-second channel availability check time.

The equipment complies with § 15.407 Radar Burst at the Beginning of the Channel Availability Check Time.

Test Engineer: Anderson Soungpanya

Test Date: 08/26/09 – 09/02/09

Radar Burst at the Beginning of Channel Availability Check Time – Plot

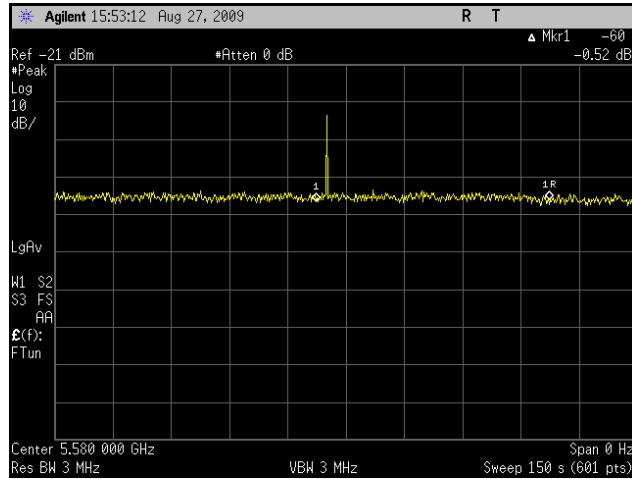

Plot 338. Radar Burst at the Beginning of CACT, 250 seconds, 5580 MHz, 802.11a

F. Radar Burst at the End of Channel Availability Check Time

Test Requirements: § 15.407 A Radar Burst at the End of the Channel Availability Check Time tests that the UUT does not emit beacon, control, or data signals on the test Channel if it has detected a radar burst during that time period until the power-up sequence has been completed and the U-NII device checks for Radar Waveforms for one minute on the test Channel. The steps below define the procedure to verify successful radar detection on the selected Channel during a period equal to the Channel Availability Check Time and avoidance of operation on that Channel when a radar Burst with a level equal to the DFS Detection Threshold + 1 dB (-63dBm) occurs at the end of the Channel Availability Check Time.

Test Procedure: The steps below define the procedure to verify successful radar detection on the selected Channel during a period equal to the Channel Availability Check Time and avoidance of operation on that Channel when a radar Burst with a level equal to the DFS Detection Threshold + 1 dB (-63dBm) occurs at the end of the Channel Availability Check Time.

The UUT is powered on at T0. T1 denotes the instant when the UUT has completed its power-up sequence. The Channel Availability Check Time commences at instant T1 and will end no sooner than T1 + 60 seconds.

A single Burst of short pulse of radar type 1 at -63 dBm will commence within a 6 second window starting at T1+ 54 seconds.

Visual indication on the UUT of successful detection of the radar Burst will be recorded and reported. Observation of emissions at 5580 MHz will continue for 2.5 minutes after the radar Burst has been generated.

Verify that during the 2.5 minute measurement window no UUT transmissions occurred at 5580MHz.

Test Results: Plot 339 indicates that no UUT transmissions occurred during the 2.5 minute measurement window. Marker 1R indicates completion of the power-on cycle. Marker 1 indicates the end of the 60-second channel availability check time.

The equipment complies with § 15.407 Radar Burst at the End of the Channel Availability Check Time.

Test Engineer: Anderson Soungpanya

Test Date: 08/26/09 – 09/02/09

Radar Burst at the End of Channel Availability Check Time – Plot

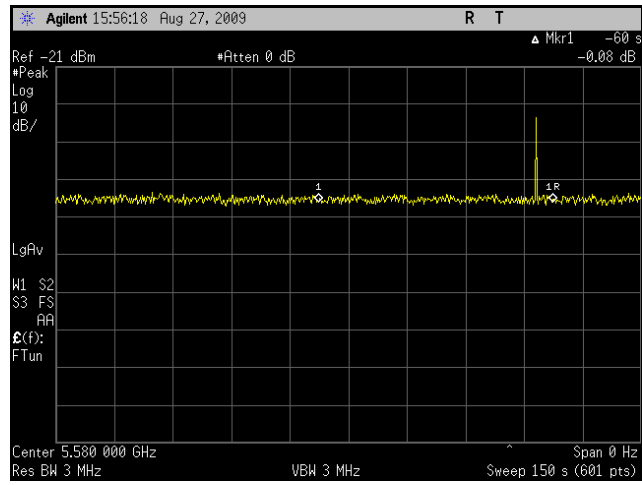

Plot 339. Radar Burst at the End of CACT, 250 seconds, 5580 MHz, 802.11a

G. In-Service Monitoring for Channel Move Time, Channel Closing Transmission Time, and Non-Occupancy Period

Test Requirements: § 15.407 (Refer to DFS Response Requirement Values table in section III-A of this report.) The UUT shall continuously monitor for radar transmissions in the operating test channel. When a radar burst occurs in the test channel, it has 10 seconds to move to another channel. This 10 second window is termed Channel Move Time (CMT).

When a radar burst occurs, the UUT has 200 milliseconds, plus an aggregate of 60 milliseconds, to cease transmission in the operating test channel. This 200 ms + 60 ms requirement is termed Channel Closing Transmission Time (CCT).

After radar burst and subsequent move to another channel, the UUT shall not resume transmission, on the channel it moved from, for a period of 30 minutes. This requirement is termed Non-Occupancy Period (NOP).

Test Procedure: These tests define how the following DFS parameters are verified during In-Service Monitoring: Channel Closing Transmission Time, Channel Move Time, and Non-Occupancy Period.

The steps below define the procedure to determine the above mentioned parameters when a radar Burst with a level equal to the DFS Detection Threshold + 1dB (-63dBm) is generated on the Operating Channel of the U-NII device.

A U-NII device operating as a Client Device will associate with the UUT (Master) at 5580MHz. Stream the MPEG test file from the Master Device to the Client Device on the selected Channel for the entire period of the test.

At time T₀ the Radar Waveform generator sends a Burst of pulses for each of the radar types at -63dBm.

Observe the transmissions of the UUT at the end of the radar Burst on the Operating Channel for duration greater than 10 seconds. Measure and record the transmissions from the UUT during the observation time (Channel Move Time). Compare the Channel Move Time and Channel Closing Transmission Time results to the limits defined in the *DFS Response Requirement Values table*.

Test Results: Plot 340 and Plot 341 indicate cessation of transmission for more than 10 seconds after a radar burst (marker 1). Plot 342 depicts the 200 ms closing time window (marker 1), and Plot 343 depicts post 200 ms aggregate transmissions. Finally, Plot 344 shows that transmissions have not resumed within 30 minutes of channel move.

The UUT complies with § 15.407 In-Service Monitoring for Channel Move Time, Channel Closing Transmission Time, and Non-Occupancy Period.

Test Engineer: Anderson Soungpanya

Test Date: 08/26/09 – 09/02/09

In-Service Monitoring for Channel Move Time – Plots

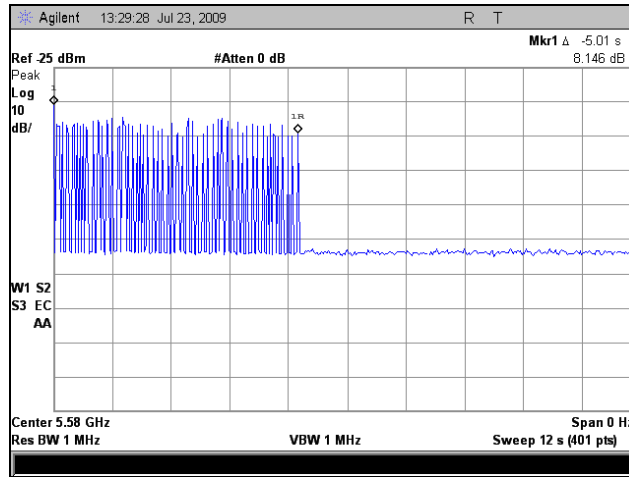

Plot 340. Channel Move Time for Radar Type 1, 10 seconds, 5580 MHz, 802.11a

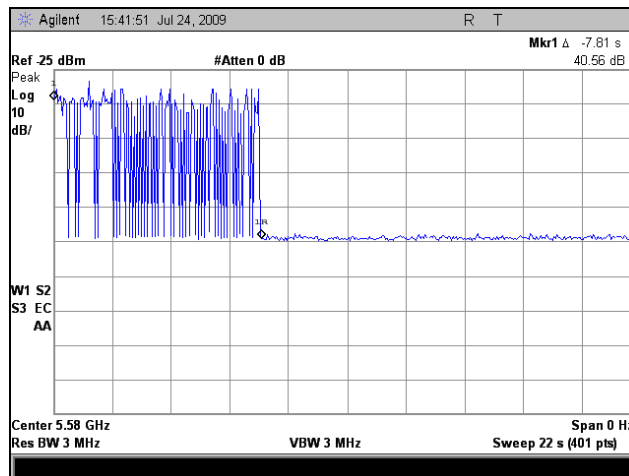

Plot 341. Channel Move Time for Radar Type 5, 22 seconds, 5580 MHz, 802.11a

In-Service Monitoring for Channel Closing Transmission Time – Plots

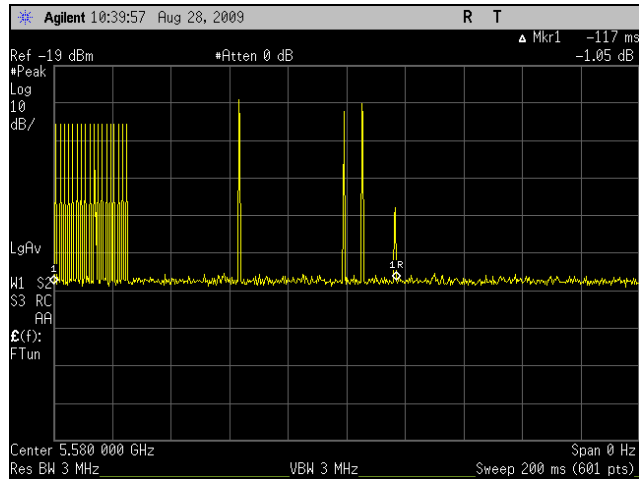

Plot 342. Channel Closing Transmission Time, 200 milliseconds, 5580 MHz, 802.11a

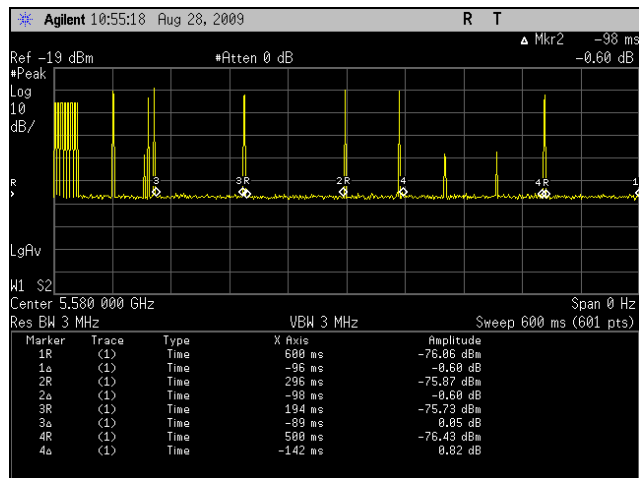

Plot 343. Channel Closing Transmission Time, 260 milliseconds, 5580 MHz, 802.11a

In-Service Monitoring for Non-Occupancy Period – Plot

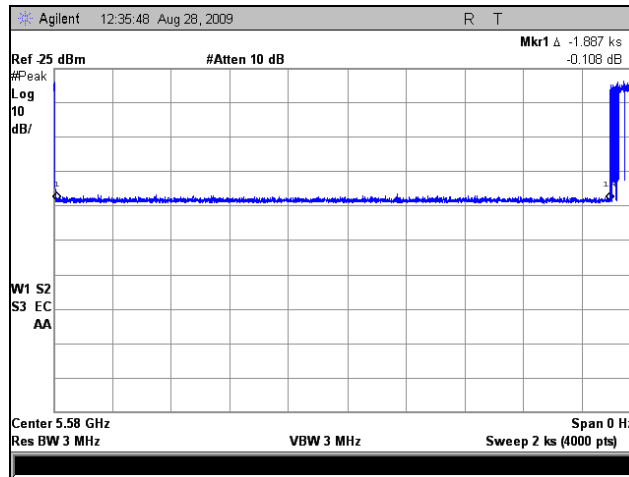

Plot 344. Non-Occupancy Period, 30minutes, 5580 MHz, 802.11a

H. Statistical Performance Check

Test Requirements: § 15.407 During In-Service Monitoring, the EUT requires a minimum percentage of successful radar detections from all required radar waveforms at a level equal to the DFS Detection Threshold + 1dB.

Test Procedure: Stream the MPEG test file from the Master Device to the Client Device on the selected Channel for the entire period of the test. The Radar Waveform generator sends the individual waveform for each of the radar types 1-6 at -63dbm. Statistical data is gathered to determine the ability of the device to detect the radar test waveforms. The device can utilize a test mode to demonstrate when detection occurs to prevent the need to reset the device between trial runs. The percentage of successful detection is calculated by:

$$\frac{\text{TotalWaveformDetections}}{\text{TotalWaveformTrials}} \times 100$$

The Minimum number of trails, minimum percentage of successful detection and the average minimum percentage of successful detection are found in the Radar Test Waveforms section.

Test Results: Statistical performance for radar type 1 is tabulated in Table 81.

The equipment complies with § 15.407 Statistical Performance Check.

Test Engineer: Anderson Soungpanya

Test Date: 08/26/09

Radar Type	Trial #	Pulses per Burst	Pulse Width (μsec)	PRI (μsec)	Detection
					1 = Yes, 0 = No
1	1	18	1	1428	1
	2	18	1	1428	1
	3	18	1	1428	1
	4	18	1	1428	1
	5	18	1	1428	1
	6	18	1	1428	1
	7	18	1	1428	1
	8	18	1	1428	1
	9	18	1	1428	1
	10	18	1	1428	1
	11	18	1	1428	1
	12	18	1	1428	1
	13	18	1	1428	1
	14	18	1	1428	1
	15	18	1	1428	1
	16	18	1	1428	1
	17	18	1	1428	1
	18	18	1	1428	1
	19	18	1	1428	1
	20	18	1	1428	1
	21	18	1	1428	1
	22	18	1	1428	1
	23	18	1	1428	1
	24	18	1	1428	1
	25	18	1	1428	1
	26	18	1	1428	1
	27	18	1	1428	1
	28	18	1	1428	1
	29	18	1	1428	1
	30	18	1	1428	1
Detection Percentage					100% (> 60%)

Table 81. Statistical Performance Check – Radar Type 1, 5580 MHz, 802.11a

Radar Type	Trial #	Pulse Width 1 to 5 μ sec	PRI 150 to 230 μ sec	Pulses per Burst 23 to 29	Detection
					1 = Yes, 0 = No
2	1	2.6	221	24	1
	2	3.7	170	28	1
	3	4.4	159	23	1
	4	3.5	187	24	1
	5	4.4	168	23	1
	6	3.5	156	23	1
	7	1.9	164	25	1
	8	3.0	198	26	1
	9	4.8	224	28	1
	10	2.6	180	27	1
	11	2.1	206	28	0
	12	1.4	191	24	1
	13	1.9	187	26	1
	14	4.1	160	29	1
	15	2.8	213	28	1
	16	4.7	202	26	1
	17	2.8	184	24	1
	18	4.8	211	23	1
	19	1.2	187	29	1
	20	4.3	208	23	1
	21	1.9	218	26	0
	22	4.4	161	29	0
	23	1.7	161	24	1
	24	1.6	204	25	1
	25	2.8	171	24	1
	26	2.7	207	24	1
	27	2.9	204	23	1
	28	1.4	219	29	1
	29	4.9	199	24	1
	30	2.3	191	26	1
Detection Percentage					90% (> 60%)

Table 82. Statistical Performance Check – Radar Type 2, 5580 MHz, 802.11a

Radar Type	Trial #	Pulse Width 6 to 10 μ sec	PRI 200 to 500 μ sec	Pulses per Burst 16 to 18	Detection
					1 = Yes, 0 = No
3	1	7.8	392	17	1
	2	7.8	364	17	1
	3	6.4	461	17	1
	4	8.1	419	16	1
	5	5.6	379	18	1
	6	8.1	439	16	1
	7	7.5	271	16	1
	8	7.0	278	16	0
	9	9.4	491	18	1
	10	7.6	260	18	1
	11	7.4	462	18	1
	12	8.3	344	17	1
	13	7.7	324	17	1
	14	9.8	308	16	1
	15	8.1	288	17	0
	16	9.2	368	16	1
	17	7.5	305	16	1
	18	9.3	292	17	1
	19	5.0	292	16	1
	20	5.3	460	16	1
	21	8.8	464	18	1
	22	7.7	461	16	1
	23	7.2	257	16	1
	24	6.1	328	18	1
	25	5.3	324	17	1
	26	6.1	452	16	1
	27	7.8	454	18	1
	28	5.8	287	16	1
	29	5.1	440	17	1
	30	8.4	441	16	1
Detection Percentage					94% (> 60%)

Table 83. Statistical Performance Check – Radar Type 3, 5580 MHz, 802.11a

Radar Type	Trial #	Pulse Width 11 to 20 μ sec	PRI 200 to 500 μ sec	Pulses per Burst 12 to 16	Detection
					1 = Yes, 0 = No
4	1	19.2	250	16	0
	2	18.7	307	15	1
	3	19.5	418	14	1
	4	13.2	351	15	1
	5	19.4	373	14	1
	6	13.3	355	16	1
	7	18.3	375	13	0
	8	13.9	370	13	1
	9	19.9	472	14	1
	10	18.4	354	12	1
	11	18.3	282	14	1
	12	19.0	413	16	1
	13	16.2	317	14	1
	14	10.5	375	14	0
	15	16.1	411	15	1
	16	15.9	412	13	1
	17	11.5	386	16	0
	18	10.3	321	12	1
	19	16.8	344	14	1
	20	15.8	324	14	1
	21	19.0	390	16	1
	22	14.3	261	13	1
	23	19.8	484	12	1
	24	14.1	380	13	1
	25	15.5	368	14	1
	26	13.9	293	14	0
	27	17.0	299	12	1
	28	12.9	292	14	1
	29	19.8	421	14	1
	30	17.8	335	14	1
Detection Percentage					84% (> 60%)

Table 84. Statistical Performance Check – Radar Type 4, 5580 MHz, 802.11a

Radar Type	Trial #	Filename*	Detection
			1 = Yes, 0 = No
5	1	bin5-trial 1	0
	2	bin5-trial 2	1
	3	bin5-trial 3	1
	4	bin5-trial 4	1
	5	bin5-trial 5	1
	6	bin5-trial 6	1
	7	bin5-trial 7	1
	8	bin5-trial 8	1
	9	bin5-trial 9	1
	10	bin5-trial 10	1
	11	bin5-trial 11	1
	12	bin5-trial 12	1
	13	bin5-trial 13	1
	14	bin5-trial 14	1
	15	bin5-trial 15	1
	16	bin5-trial 16	1
	17	bin5-trial 17	1
	18	bin5-trial 18	1
	19	bin5-trial 19	1
	20	bin5-trial 20	1
	21	bin5-trial 21	1
	22	bin5-trial 22	1
	23	bin5-trial 23	1
	24	bin5-trial 24	1
	25	bin5-trial 25	1
	26	bin5-trial 26	1
	27	bin5-trial 27	1
	28	bin5-trial 28	1
	29	bin5-trial 29	1
	30	bin5-trial 30	1
Detection Percentage			97% (> 80%)

Table 85. Statistical Performance Check – Radar Type 5, 5580 MHz, 802.11a

Note: See Appendix

Radar Type	Trial #	Frequency (MHz)	Pulses/Hop	Pulse Width (µsec)	PRI (µsec)	Detection
						1 = Yes, 0 = No
6	1	5580	9	1	333	1
	2	5580	9	1	333	1
	3	5580	9	1	333	1
	4	5580	9	1	333	1
	5	5580	9	1	333	1
	6	5580	9	1	333	1
	7	5580	9	1	333	1
	8	5580	9	1	333	1
	9	5580	9	1	333	1
	10	5580	9	1	333	1
	11	5580	9	1	333	1
	12	5580	9	1	333	1
	13	5580	9	1	333	1
	14	5580	9	1	333	1
	15	5580	9	1	333	1
	16	5580	9	1	333	1
	17	5580	9	1	333	1
	18	5580	9	1	333	1
	19	5580	9	1	333	1
	20	5580	9	1	333	1
	21	5580	9	1	333	1
	22	5580	9	1	333	1
	23	5580	9	1	333	1
	24	5580	9	1	333	1
	25	5580	9	1	333	1
	26	5580	9	1	333	1
	27	5580	9	1	333	1
	28	5580	9	1	333	1
	29	5580	9	1	333	1
	30	5580	9	1	333	1
Detection Percentage						100% (> 70%)

Table 86. Statistical Performance Check – Radar Type 6, 5580 MHz, 802.11a

Radar Type	Trial #	Pulses per Burst	Pulse Width (μsec)	PRI (μsec)	Detection
					1 = Yes, 0 = No
1	1	18	1	1428	1
	2	18	1	1428	1
	3	18	1	1428	1
	4	18	1	1428	1
	5	18	1	1428	1
	6	18	1	1428	1
	7	18	1	1428	0
	8	18	1	1428	1
	9	18	1	1428	0
	10	18	1	1428	1
	11	18	1	1428	1
	12	18	1	1428	1
	13	18	1	1428	0
	14	18	1	1428	1
	15	18	1	1428	1
	16	18	1	1428	1
	17	18	1	1428	1
	18	18	1	1428	0
	19	18	1	1428	1
	20	18	1	1428	1
	21	18	1	1428	1
	22	18	1	1428	1
	23	18	1	1428	1
	24	18	1	1428	1
	25	18	1	1428	1
	26	18	1	1428	1
	27	18	1	1428	1
	28	18	1	1428	1
	29	18	1	1428	1
	30	18	1	1428	0
Detection Percentage					84% (> 60%)

Table 87. Statistical Performance Check – Radar Type 1, 5310 MHz, 802.11n 40MHz

Radar Type	Trial #	Pulse Width 1 to 5 μ sec	PRI 150 to 230 μ sec	Pulses per Burst 23 to 29	Detection
					1 = Yes, 0 = No
2	1	4.1	203	26	1
	2	1.4	160	28	1
	3	3	194	28	0
	4	1.4	174	25	1
	5	1.6	218	25	1
	6	4.2	215	27	1
	7	3.5	214	24	1
	8	3	155	23	1
	9	3.2	180	23	1
	10	1.3	201	25	1
	11	4.9	213	24	0
	12	4.7	207	25	1
	13	3.1	194	28	1
	14	4.1	203	23	1
	15	1.9	169	25	1
	16	1	208	26	1
	17	2.7	192	29	1
	18	1.4	186	23	1
	19	1.9	188	29	1
	20	2	221	23	1
	21	2.3	183	24	0
	22	2.2	230	26	1
	23	2	211	28	1
	24	3.6	218	29	0
	25	2.5	210	28	1
	26	4.8	205	27	0
	27	1.7	153	28	1
	28	3.4	169	27	1
	29	2.9	217	29	1
	30	3.5	182	28	1
Detection Percentage					84% (> 60%)

Table 88. Statistical Performance Check – Radar Type 2, 5310 MHz, 802.11n 40MHz

Radar Type	Trial #	Pulse Width 6 to 10 μ sec	PRI 200 to 500 μ sec	Pulses per Burst 16 to 18	Detection
					1 = Yes, 0 = No
3	1	9.7	448	18	1
	2	8.1	451	18	1
	3	7.4	287	16	1
	4	5.9	433	18	0
	5	9.9	424	17	1
	6	7.2	435	18	0
	7	8.2	477	17	0
	8	9.2	475	17	1
	9	6.3	317	16	1
	10	6.7	274	17	1
	11	5	337	17	1
	12	8.5	398	18	1
	13	5.7	476	18	1
	14	9.6	368	17	1
	15	9	421	17	1
	16	5.1	457	16	1
	17	6.2	394	17	1
	18	7.1	389	17	1
	19	6.1	443	18	1
	20	5.1	429	16	1
	21	9.2	267	16	1
	22	5.9	266	18	1
	23	7.6	353	18	1
	24	6.5	449	17	1
	25	8.6	371	16	1
	26	9.8	329	16	1
	27	6.8	338	18	1
	28	5.6	346	18	1
	29	9.9	453	17	1
	30	6.7	288	18	1
Detection Percentage					90% (> 60%)

Table 89. Statistical Performance Check – Radar Type 3, 5310 MHz, 802.11n 40MHz

Radar Type	Trial #	Pulse Width 11 to 20 μ sec	PRI 200 to 500 μ sec	Pulses per Burst 12 to 16	Detection
					1 = Yes, 0 = No
4	1	11.9	362	15	1
	2	18.1	267	16	1
	3	12.3	452	14	1
	4	19.2	492	14	0
	5	11.4	277	14	1
	6	11.4	437	12	1
	7	11	342	16	1
	8	11	311	12	1
	9	19.2	485	16	0
	10	10.8	318	14	1
	11	16.2	329	15	1
	12	16.7	363	15	1
	13	11.9	251	16	1
	14	19.6	282	13	1
	15	14.7	394	15	1
	16	16.4	500	15	1
	17	12.1	443	16	1
	18	19.6	360	15	1
	19	11.9	374	16	1
	20	12.2	471	12	1
	21	13.9	349	14	1
	22	19.4	369	15	1
	23	14.8	300	13	1
	24	17.3	261	12	1
	25	16.9	368	15	1
	26	19.1	325	15	1
	27	14.5	404	14	1
	28	15.5	439	14	1
	29	14.7	399	15	1
	30	13.1	254	15	1
Detection Percentage					94% (> 60%)

Table 90. Statistical Performance Check – Radar Type 4, 5310 MHz, 802.11n 40MHz

Radar Type	Trial #	Filename*	Detection
			1 = Yes, 0 = No
5	1	bin5-trial 1	1
	2	bin5-trial 2	1
	3	bin5-trial 3	0
	4	bin5-trial 4	1
	5	bin5-trial 5	1
	6	bin5-trial 6	1
	7	bin5-trial 7	1
	8	bin5-trial 8	1
	9	bin5-trial 9	1
	10	bin5-trial 10	1
	11	bin5-trial 11	1
	12	bin5-trial 12	1
	13	bin5-trial 13	0
	14	bin5-trial 14	1
	15	bin5-trial 15	1
	16	bin5-trial 16	1
	17	bin5-trial 17	1
	18	bin5-trial 18	1
	19	bin5-trial 19	1
	20	bin5-trial 20	1
	21	bin5-trial 21	1
	22	bin5-trial 22	1
	23	bin5-trial 23	1
	24	bin5-trial 24	1
	25	bin5-trial 25	1
	26	bin5-trial 26	1
	27	bin5-trial 27	1
	28	bin5-trial 28	1
	29	bin5-trial 29	1
	30	bin5-trial 30	1
Detection Percentage			94% (> 80%)

Table 91. Statistical Performance Check – Radar Type 5, 5310 MHz, 802.11n 40MHz

Note: See Appendix

Radar Type	Trial #	Frequency (MHz)	Pulses/Hop	Pulse Width (µsec)	PRI (µsec)	Detection
						1 = Yes, 0 = No
6	1	5310	9	1	333	1
	2	5310	9	1	333	1
	3	5310	9	1	333	1
	4	5310	9	1	333	1
	5	5310	9	1	333	1
	6	5310	9	1	333	1
	7	5310	9	1	333	1
	8	5310	9	1	333	1
	9	5310	9	1	333	1
	10	5310	9	1	333	1
	11	5310	9	1	333	1
	12	5310	9	1	333	1
	13	5310	9	1	333	1
	14	5310	9	1	333	1
	15	5310	9	1	333	1
	16	5310	9	1	333	1
	17	5310	9	1	333	1
	18	5310	9	1	333	1
	19	5310	9	1	333	1
	20	5310	9	1	333	1
	21	5310	9	1	333	1
	22	5310	9	1	333	1
	23	5310	9	1	333	1
	24	5310	9	1	333	1
	25	5310	9	1	333	1
	26	5310	9	1	333	1
	27	5310	9	1	333	1
	28	5310	9	1	333	1
	29	5310	9	1	333	1
	30	5310	9	1	333	1
Detection Percentage						100% (> 70%)

Table 92. Statistical Performance Check – Radar Type 6, 5310 MHz, 802.11n 40MHz