

READ AND UNDERSTAND THE  
INSTRUCTION BEFORE FLYING

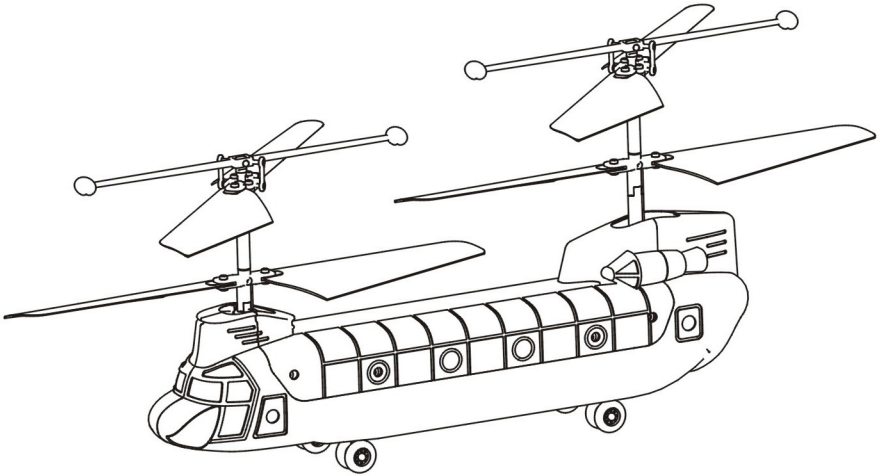

TM



## WIRELESS RC TRANSPORT HELICOPTER INSTRUCTION MANUAL

1. **Intelligentized R/C system.**
2. **Full scale remote control.**
3. **360° exact directional.**
4. **Smooth hang performance.**
5. **Newly designed electricity saving function.**
6. **Safeguard battery model to prolong the uses life.**

# 9058

Main rotor diameter:	180mm
Length:	220mm
Machine height:	125mm
Battery:	3.7V 450mAh Lithium-ion polymer battery

## INCLUDED PARTS NAME:

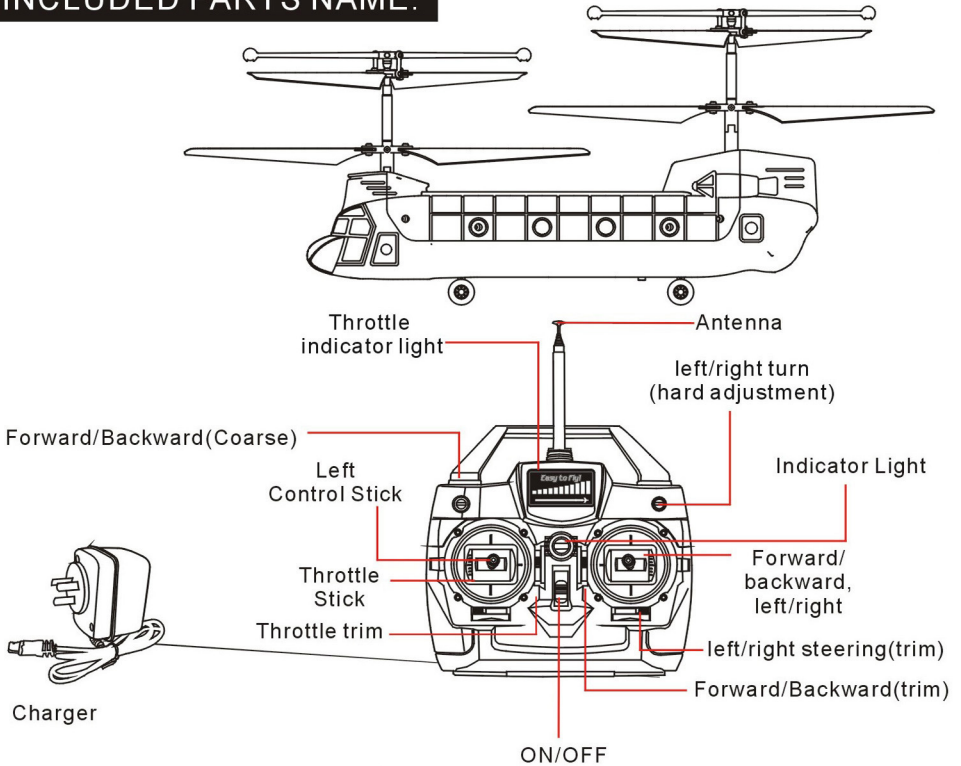

## ASSEMBLY TRANSMITTER

1. Install antenna cord: remove antenna into adapter clockwise.
2. Install batteries: Open the cover of battery case, unplug the plug from the battery case and remove the battery case followed by polar indicator, then insert 8x"AA" alkaline batteries (Batteries to be purchased). Load the battery case to the radio controller, insert the plug into the radio controller and then replace the cover of battery case.(shown on pic.2)

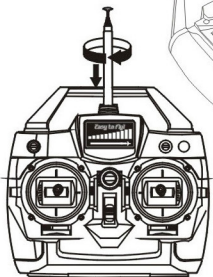
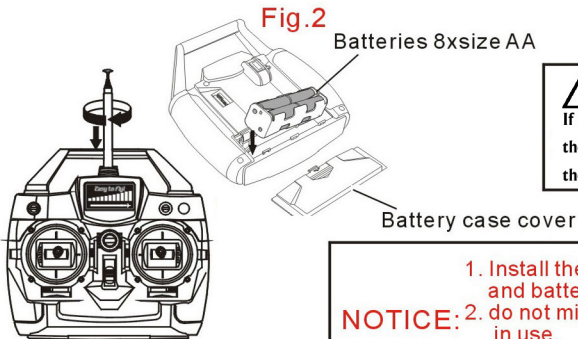

### Caution

If the battery is intended to be replaced by the user, there shall be a warning close to the battery or in both the instructions for use and the service instructions.

- NOTICE:**
1. Install the battery must recognize the battery and battery box is precise
  2. do not mix new and old batteries together when in use.
  3. Please don't mix different types of batteries when in use

## POWER BATTERIES CHARGING INSTRUCTION

Make sure the helicopter switch is on "OFF" position before charge, remove the adapter, connect the adapter to the local power, just then, the indicator light of adapter will light up, then gently plug the electric wire of charge into the small faucet under the helicopter. (as shown)Note:can only be connected one way, do not force to connect them all together, you should connect each parts carefully. When connect the helicopter with charger, the indicator light of adapter is bright, it means that is charging. If the helicopter are fully recharge and charge once more, the indicator light cannot bright, moreover cannot continue to charge. When the indicator light is dark, it means that charging is completed. Unplug pontes of the electric wire of charge on the helicopter.

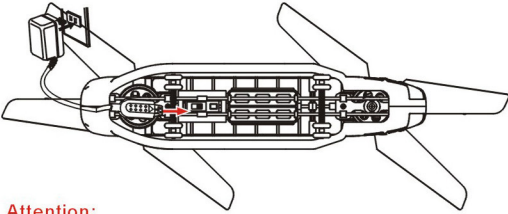

### WARNING

When you are tired of playing, please pull out the connecting plug to avoid the battery overdischarge, if the linker keeping to connected, it may cause the overdischarge as the battery long time power wasting.

#### Attention:

1. Make sure the voltage and connector plug of adapter tally with the local charging standard.
2. The battery pack will become warm when charging excessively. it is harmful for the battery pack and would even make the battery pack damaged, please stop charging under this situation.
3. Player should stand aside as the plane in the process of charging.
4. This adapter adopted the advanced balance charging model for safety, please do not use other type of adapter in order to avoid explode.
5. The battery pack would become very hot when the plane finish flying, please wait at least 30 mins for continue charging in order to protect the battery pack.
6. Do not throw the battery pack into fire for avoid explode.

## ENVIRONMENT FOR FLIGHT:

1. Fly on a sunny day, without wind.
  - ① Do not fly in extreme temperature.  
Do not fly in temperature above 113 degrees fahrenheit/45 degrees centigrade, or below 50 degrees fahrenheit/10 degrees centigrade.  
Flying in extreme heat and/of cold will affect performance and may damage the model.
  - ② Do not fly in strong wind.  
Windy conditions will limit, or disturb the flying control.  
In very windy conditions, your helicopter may become lost and/or damaged.
2. Select a large, wide-open area for flying, and make sure that there is no obstructions, animals or people nearby.

**Notes:** This device complies with part 15 of the FCC Rules.

Operation is subject to the following two conditions:

- (1) this device may not cause harmful interference,
- (2) this device must accept any interference received, including interference that may cause undesired operation.

**Changes or modifications not expressly approved by the party responsible for compliance could void the user's authority to operate the equipment.**

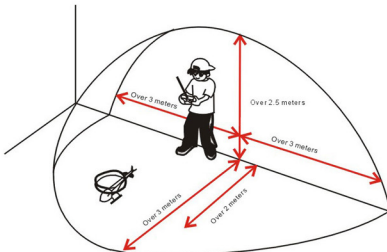

# CONTROL METHOD

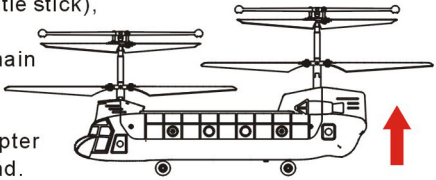
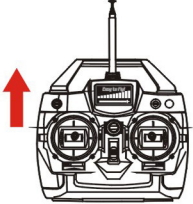
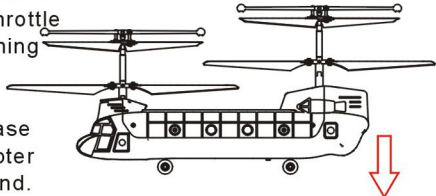
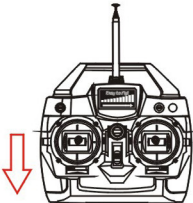
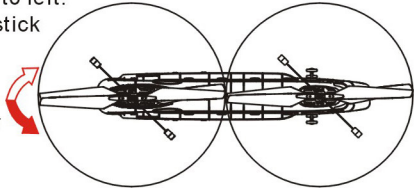
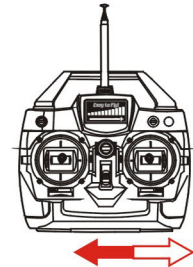
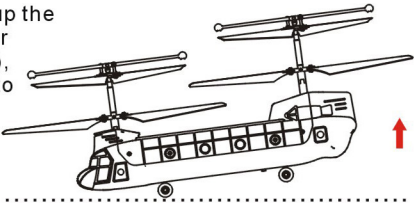
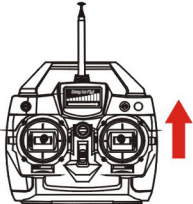
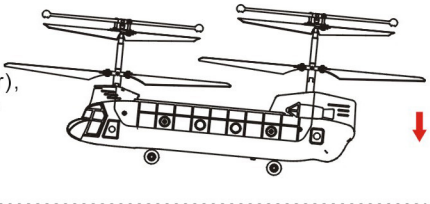
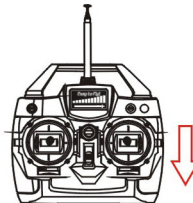
<p>Ascend</p>	<p>When you push up the left stick (throttle stick), the spinning speed of the main rotor blade is increase and the helicopter begin to ascend.</p> 	
<p>Descend</p>	<p>When you pull down the left stick (throttle stick), the spinning speed of the main rotor blade is decrease and the helicopter begin to descend.</p> 	
<p>Steering</p>	<p>1. When the right stick (rudder stick) is moving to left, the head of the helicopter turns to left. 2. When the right stick (rudder stick) is moving to right, the head of the helicopter turns to right.</p> 	
<p>Forward</p>	<p>When you push up the right control lever (steering rudder), the nose incline to down, the helicopter is moving to forward.</p> 	
<p>Backward</p>	<p>When you push down the right control lever (steering rudder), the nose incline to up, the helicopter is moving to backward..</p> 	

## SPECIAL TIPS:

In preparation for take-off, the aircraft must be a smooth adjustment:

1. Push up the throttle gradually to let the aircraft left the ground, you can be observed that the focus of the direction of the aircraft, during the swing back and forth is the bigger (Fig. 1), you can use the forward/backward coarse to balance.

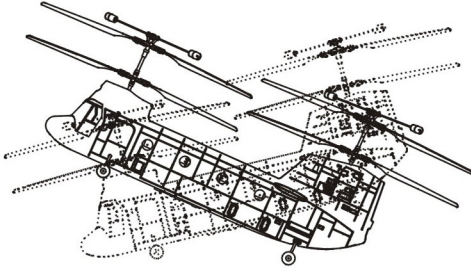

### NOTICE:

When the airplane away from the ground in 30cm position, the helicopter will suffer by itself blade vortex to become unstable, we call it "effect response", when the helicopter weight lower, and the "effect response" affect will be bigger.

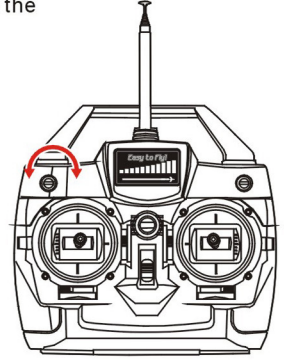

2. When the helicopter is turning to left, please push the rudder trim to right slowly until the helicopter is still.

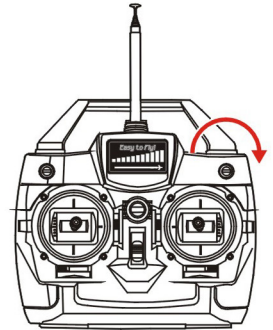
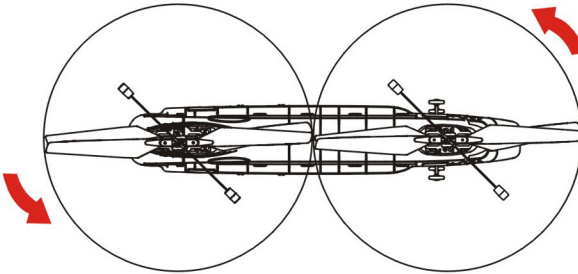

3. When the helicopter is turning to right, please push the rudder trim to left slowly until the helicopter is still.

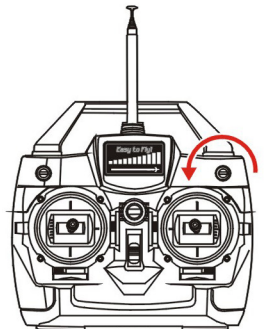
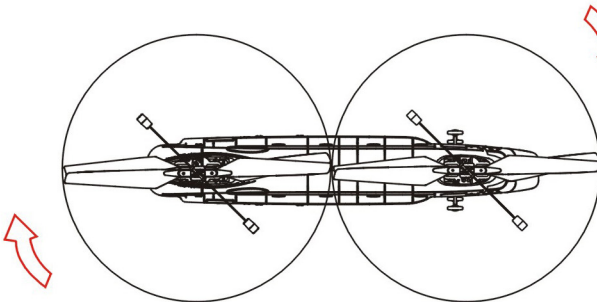

## TROUBLE SHOOT AND DEALING WITH

PROBLEM	CAUSE	CHECK THIS
Controller doesn't work	1. Controller's power switch is off.	1. Turn power switch on.
	2. Insert batteries into controller improperly.	2. Confirm batteries be inserted according to their pole.
	3. Batteries lack of power.	3. Change new batteries instead.
Can not control the helicopter	1. You haven't operated the controller.	1. Turn controller power switch on.
	2. Doesn't turn on controller's power switch.	2. Turn helicopter's power switch on.
	3. Doesn't wrest antenna into controller completely, or antenna isn't fully pulled out.	3. Wrest antenna completely and pull it out.
	4. You play the helicopter in strong winds weather.	4. Do not play the chopper in winds, which can confuse your control.
	5. The indicator light of controller is twinkle.	5. Pulling the power control rod upwards, then again return to pulling to the lowest, or change battery.
Helicopter can not rise	1. Main rotor blades rotate too slowly.	1. Pull up the throttle stick.
	2. Doesn't fully charge helicopter's battery.	2. Full charge helicopter battery. ( see instruction above)
Helicopter land too fast.	You loose the throttle stick or pull it down too fast.	Slowly pull down the throttle till the chopper landing smoothly.

### CAUTION

1. The control distance will shorter when the quantity of electricity is not full.
2. When the quantity of the electricity of the helicopter is not full, the helicopter will launch difficultly or the height of fly is not enough.
3. If the helicopter become damaged, deformation, please repaired in time.  
If the rotor become damaged or broken, do not fly, otherwise, it will lead to injury.
4. If you don't use the transmitter for a long time. Remove all batteries out, in order to avoid the battery leakage to damage this product.
5. Don't drop the helicopter from high position or crash it seriously, because that will damage it seriously or shorten the using time.
6. Before flight, always turn on the power switch on the controller and then turn on helicopter, Otherwise the radio signals of helicopter will be in confusion.
7. After flight, always turn off the power switch on the helicopter and then turn off the controller, Otherwise the radio signals of helicopter will be mixed up and you will lose control to your model.

# PARTS ARE ALTERNATIVE

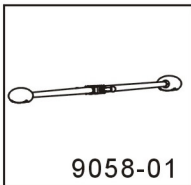

Balance Bar

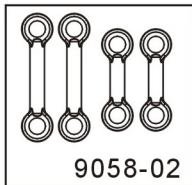

Connect buckle

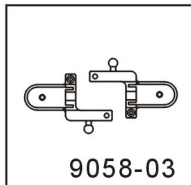

Upper blade mount

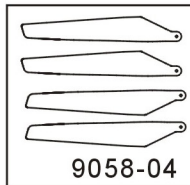

Main blade AB

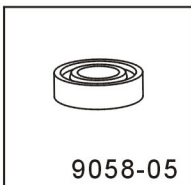

Bearing(7×4×2)

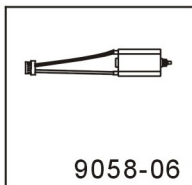

A blade main motor unit

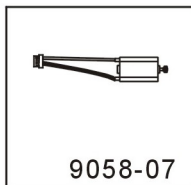

B blade main motor unit

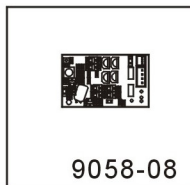

PCB

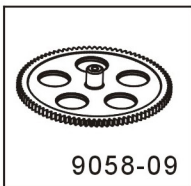

Gear A

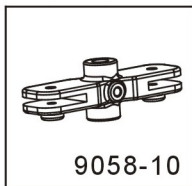

Lower blade mount

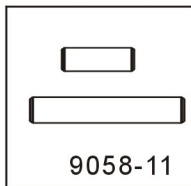

Bushing



Fuselage linkage



Battery frame



Horse

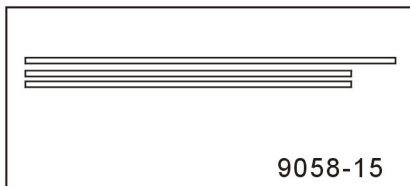

Main body linkage



Main frame



Base

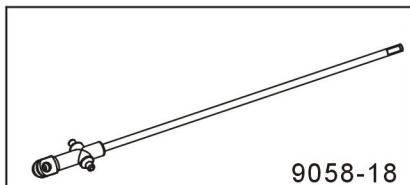

Inner shaft

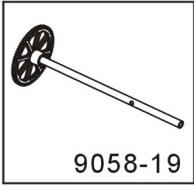

Gear set

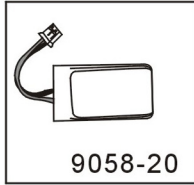

Lithium-ion polymer battery

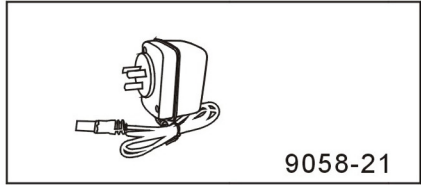

Charger

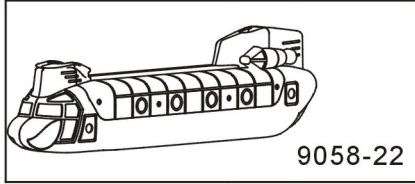

Shell unit A

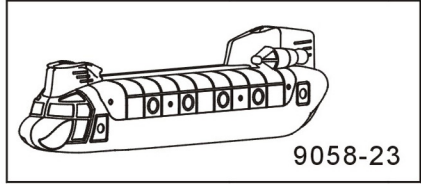

Shell unit B