



198 Kezhu Road, Sciencetech Park, Guangzhou Economic & Techr
Development District, Guangzhou, China 510663
Telephone: +86 (0) 20 82155555
Fax: +86 (0) 20 82075059
Email: sgs_internet_operations@sgs.com
FEDERAL COMMUNICATIONS COMMISSION
Registration number: 282399

Report No.: GLEMO081003135RFT
Page: 1 of 18
FCC ID: U2N-GC887850

TEST REPORT

Application No. : GLEMO081003135RF
Applicant: DOUBLE HORSE TOYS INDUSTRY., LTD
FCC ID: U2N-GC887850
Fundamental Frequency : 27.149MHz (inter modulation)
Equipment Under Test (EUT):
EUT Name: Radio controlled helicopter
Model No.: 9058, 9066, 9068, 9069, 9070, 9072, 9073, 9077, 9078, 9079, 9091♣
♣ Please refer to section 2 of this report which indicates which Item was actually tested and which were electrically identical.
Standards: FCC PART 15C: 2008
Date of Receipt: October 16, 2008
Date of Test: October 17 to October 24, 2008
Date of Issue: November 03, 2008

Test Result :	PASS *
----------------------	---------------

* In the configuration tested, the EUT detailed in this report complied with the standards specified above. Please refer to section 2 of this report for further details..

Authorized Signature:

Stephen Guo
Lab Manager

The manufacturer should ensure that all products in series production are in conformity with the product sample detailed in this report. If the product in this report is used in any configuration other than that detailed in the report, the manufacturer must ensure the new system complies with all relevant standards.

The report must not be used by the client to claim product certification, approval, or endorsement by NVLAP, NIST, or any agency of the federal government. All test results in this report can be traceable to National or International Standards.

This document is issued by the Company under its General Conditions of Service printed overleaf or available on request and accessible at http://www.sgs.com/terms_and_conditions.htm. Attention is drawn to the limitation of liability, indemnification and jurisdiction issues defined therein. Any holder of this document is advised that information contained hereon reflects the Company's findings at the time of its intervention only and within the limits of Client's instructions, if any. The Company's sole responsibility is to its Client and this document does not exonerate parties to a transaction from exercising all their rights and obligations under the transaction documents. Any unauthorized alteration, forgery or falsification of the content or appearance of this document is unlawful and offenders may be prosecuted to the fullest extent of the law." Unless otherwise stated the results shown in this test report refer only to the sample(s) tested. This document cannot be reproduced except in full, without prior approval of the Company.

2 Test Summary

Test	Test Requirement	Standard Paragraph	Result
Radiated Emission (30MHz to 1000MHz)	FCC PART 15 :2008	Section 15.227	PASS
Occupied Bandwidth	FCC PART 15 :2008	Section 15.215	PASS

Tx: In this whole report Tx (or tx) means Transmitter.

Rx: In this whole report Rx (or rx) means Receiver.

RF: In this whole report RF means Radiated Frequency.

Remark:

♣: Item No.: 9058, 9066, 9068, 9069, 9070, 9072, 9073, 9077, 9078, 9079, 9091

Only the Item 9058 was tested, since the electrical circuit design, PCB layout, components used and internal wiring were identical for the above items, only the outer decoration, color and item numbers were different according to the conformation from the applicant (manufacturer).



3 Contents

	Page
1 COVER PAGE	1
2 TEST SUMMARY	2
3 CONTENTS	3
4 GENERAL INFORMATION.....	4
4.1 CLIENT INFORMATION.....	4
4.2 DETAILS OF E.U.T.	4
4.3 DESCRIPTION OF SUPPORT UNITS.....	4
4.4 STANDARDS APPLICABLE FOR TESTING	4
4.5 TEST LOCATION	4
4.6 OTHER INFORMATION REQUESTED BY THE CUSTOMER	4
4.7 TEST FACILITY	5
5 EQUIPMENTS USED DURING TEST.....	6
6 TEST RESULTS	7
6.1 E.U.T. TEST CONDITIONS	7
6.2 RADIATED EMISSIONS	8
6.3 OCCUPIED BANDWIDTH	13

4 General Information

4.1 Client Information

Applicant Name: DOUBLE HORSE TOYS INDUSTRY., LTD

Applicant Address: Donghu Industrial Park, Chenghai, Shantou City, Guangdong P.R.China

4.2 Details of E.U.T.

EUT Name: Radio controlled helicopter

Item No.: 9058, 9066, 9068, 9069, 9070, 9072, 9073, 9077, 9078, 9079, 9091

Power Supply: 12V DC (Size: "AA" 1.5V x 8)

Power Cord: N/A

4.3 Description of Support Units

The EUT was tested as an independent unit: 27.149MHz radio transmitter.

4.4 Standards Applicable for Testing

The customer requested FCC tests for the EUT.

The standard used was FCC PART 15, SUBPART C: 2008.

4.5 Test Location

All tests were performed at:

SGS-CSTC Standards Technical Services Co., Ltd., Guangzhou EMC Laboratory,
198 Kezhu Road, Sciencetech Park, Guangzhou Economic & Technology Development District,
Guangzhou, China 510663

Tel: +86 20 82155555 Fax: +86 20 82075059

No tests were sub-contracted.

4.6 Other Information Requested by the Customer

None.

4.7 Test Facility

The test facility is recognized, certified, or accredited by the following organizations:

- **NVLAP – Lab Code: 200611-0**

SGS-CSTC Standards Technical Services Co., Ltd., Guangzhou EMC Laboratory is recognized under the National Voluntary Laboratory Accreditation Program (NVLAP/NIST). NVLAP Code: 200611-0.

- **FCC – Registration No.: 282399**

SGS-CSTC Standards Technical Services Co., Ltd., EMC Laboratory has been registered and fully described in a report filed with the (FCC) Federal Communications Commission. The acceptance letter from the FCC is maintained in our files. Registration 282399, May 31, 2002. With the above and NVLAP's accreditation, SGS-CSTC is an authorized test laboratory for the DoC process.

5 Equipments Used during Test

RE in Chamber						
No:	Test Equipment	Manufacturer	Model No.	Serial No.	Cal. Date (dd-mm-yy)	Cal.Due date (dd-mm-yy)
EMC0525	Compact Semi-Anechoic Chamber	ChangZhou ZhongYu	N/A	N/A	N/A	N/A
EMC0522	EMI Test Receiver	Rohde & Schwarz	ESIB26	100249	28-01-2008	28-01-2009
N/A	EMI Test Software	Audix	E3	N/A	N/A	N/A
EMC0514	Coaxial cable	SGS	N/A	N/A	04-12-2007	04-12-2008
EMC0524	Bi-log Type Antenna	Schaffner -Chase	CBL6112B	2966	12-08-2008	12-08-2009
EMC0519	Bilog Type Antenna	Schaffner -Chase	CBL6143	5070	12-08-2008	12-08-2009
EMC0517	Horn Antenna	Rohde & Schwarz	HF906	100095	12-08-2008	12-08-2009
EMC0040	Spectrum Analyzer	Rohde & Schwarz	FSP30	100324	05-12-2008	05-12-2009
EMC0520	0.1-1300 MHz Pre-Amplifier	HP	8447D OPT 010	2944A06252	11-03-2008	11-03-2009
EMC0521	1-26.5 GHz Pre-Amplifier	Agilent	8449B	3008A01649	11-03-2008	11-03-2009
EMC0075	310N Amplifier	Sonama	310N	272683	10-09-2008	10-09-2009
EMC0523	Active Loop Antenna	EMCO	6502	00042963	09-08-2008	09-08-2010
EMC0530	10m Semi- Anechoic Chamber	ETS	N/A	N/A	10-08-2008	10-08-2009

General used equipment						
No:	Test Equipment	Manufacturer	Model No.	Serial No.	Cal. Date (dd-mm-yy)	Cal.Due date (dd-mm-yy)
EMC0006	DMM	Fluke	73	70681569	27-09-2008	27-09-2009
EMC0007	DMM	Fluke	73	70671122	27-09-2008	27-09-2009

6 Test Results

6.1 E.U.T. test conditions

Requirements: **15.31(e)** :For intentional radiators, measurements of the variation of the input power or the radiated signal level of the fundamental frequency component of the emission, as appropriate, shall be performed with the supply voltage varied between 85% and 115% of the nominal rated supply voltage. For battery operated equipment, the equipment tests shall be performed using a new battery.

Power supply: 12V DC (Size: "AA" 1.5Vx 8) (New batteries)

Type of antenna: Integral

Operating Environment:

Temperature: 22-25.0 °C

Humidity: 48-55% RH

Atmospheric Pressure: 1001-1010 mbar

Test frequencies: According to the 15.31(m) Measurements on intentional radiators or receivers, other than TV broadcast receivers, shall be performed and, if required, reported for each band in which the device can be operated with the device operating at the number of frequencies in each band specified in the following table:

Frequency range over which device operates	Number of frequencies	Location in the range of operation
1 MHz or less	1	Middle
1 to 10 MHz	2	1 near top and 1 near bottom
More than 10 MHz	3	1 near top, 1 near middle and 1 near bottom

Test nominal frequency: 27.149MHz

6.2 Radiated Emissions

Test Requirement:	FCC Part15 C Section 15.227
Test Method:	ANSI C63.4
Test Date:	October 24, 2008
Measurement Distance:	3m (Semi-Anechoic Chamber)
Requirements:	<p>15.227(a) :The field strength of any emission within this band shall not exceed 10,000 microvolts/meter at 3 meters. The emission limit in this paragraph is based on measurement instrumentation employing an average detector. The provisions in Section 15.35 for limiting peak emissions apply.</p> <p>15.227(b) :The field strength of any emissions which appear outside of this band shall not exceed the general radiated emission limits in Section 15.209.</p> <p>Out of band emissions shall not exceed:</p> <p>40.0 dBμV/m between 30MHz & 88MHz 43.5 dBμV/m between 88MHz & 216MHz 46.0 dBμV/m between 216MHz & 960MHz 54.0 dBμV/m above 960MHz</p>
Detector:	Peak Scan (9kHz resolution bandwidth for 9kHz to 30MHz; 120kHz resolution bandwidth for 30MHz to 1000MHz)
Test Procedure:	<p>1)9K to 30MHz emissions: For testing performed with the loop antenna, testing was performed in accordance to ANSI C63.4 section 8.2.1. The center of the loop was positioned 1 m above the ground and positioned with its plane vertical at the specied distance from the EUT.During testing the loop was rotated about its vertical axis for maximum response at each azimuth and also investigated with the loop positioned in the horizontal plane.</p> <p>2)30MHz to 1GHz emissions: For testing performed with the bi-log type antenna, testing was performed in accordance to ANSI 63.4. The measurement is performed with the EUT rotated 360°, the antenna height scanned between 1m and 4m, and the antenna rotated to repeat the measurement for both the horizontal and vertical antenna polarizations.</p> <p>3)1GHz to 40GHz emissions: For testing performed with the horn antenna, testing was performed in accordance to ANSI 63.4. The measurement is performed with the EUT rotated 360°, the antenna height scanned between 1m and 4m, and the antenna rotated to repeat the measurement for both the horizontal and vertical antenna polarizations.</p>

Test Configuration:

- 1) 9K to 30MHz emissions:

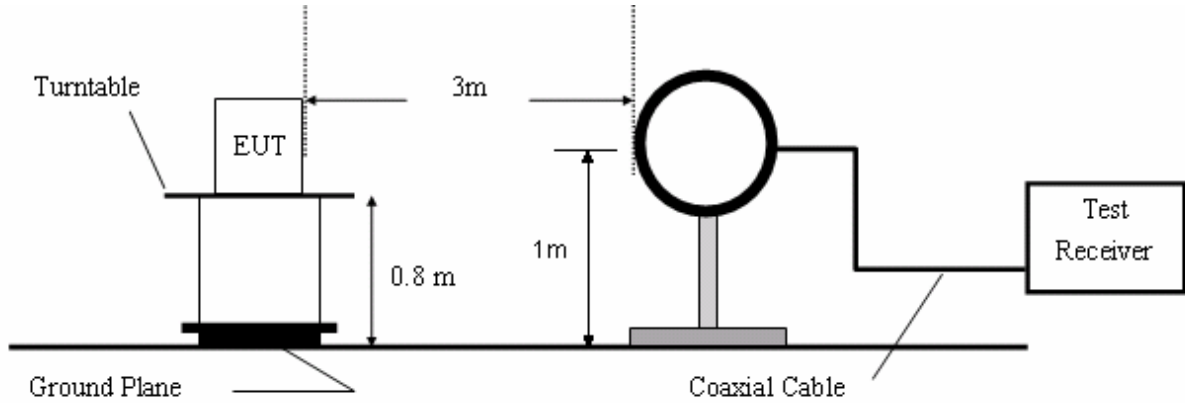

- 2) 30MHz to 1GHz emissions:

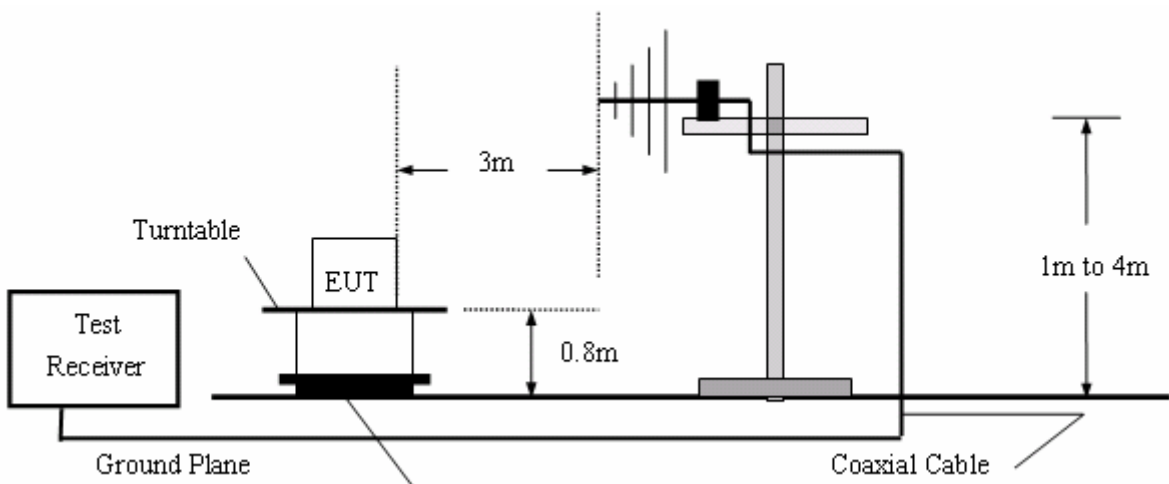

- 3) 1GHz to 40GHz emissions:

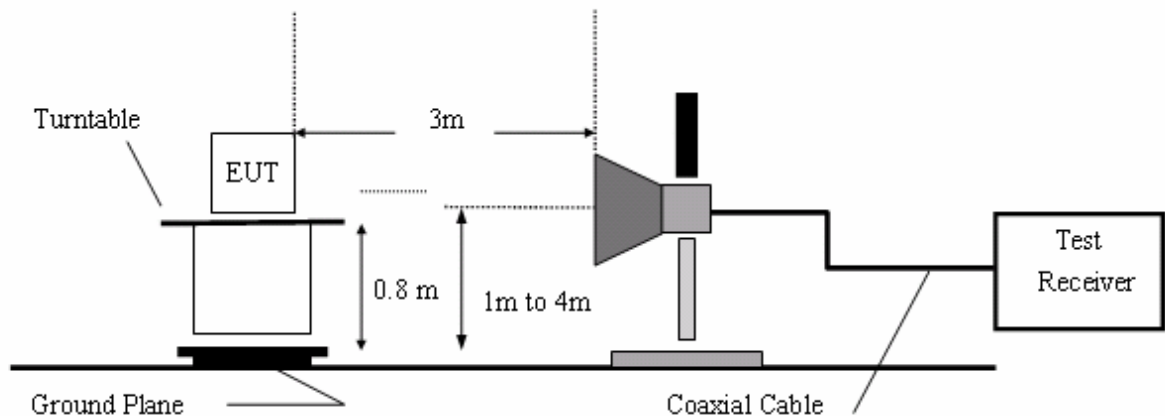

1) Emissions below 30MHz:

Vertical:

Test Frequency (MHz)	Peak (dBµV/m)			Limits (dBµV/m)	Margin (dB)		
	X	Y	Z		X	Y	Z
27.149	51.5	61.2	60.7	100.0	48.5	38.8	39.3
Test Frequency (MHz)	Average (dBµV/m)			Limits (dBµV/m)	Margin (dB)		
	X	Y	Z		X	Y	Z
27.149	47.2	58.0	48.3	80.0	32.8	22.0	31.7

Y: EUT as Radiated Emission test setup photograph in section 6 of this report.

X: rotate EUT by 90° clockwise.

Z: rotate EUT by 90° vertically.

According to ANSI Standard C63.4-2003, the portable equipment shall be tested with X, Y, Z axis of the EUT to find the maximum emissions. Other equipment shall be put in normal use status to find the maximum emissions.

2) other emissions

Test Procedure: The procedure used was ANSI Standard C63.4-2003. The receive was scanned from 30MHz to 1000MHz. When an emission was found, the table was rotated to produce the maximum signal strength. An initial pre-scan was performed for in peak detection mode using the receiver. The EUT was measured for both the Horizontal and Vertical polarities and performed a pre-test three orthogonal planes. The worst case emissions were reported.

An initial pre-scan was performed in the 3m chamber using the spectrum analyser in peak detection mode. Quasi-peak measurements were conducted based on the peak sweep graph. The EUT was measured by Bilog antenna with 2 orthogonal polarities

The field strength is calculated by adding the Antenna Factor, Cable Factor & Peramplifier. The basic equation with a sample calculation is as follows:

Final Test Level = Receiver Reading + Antenna Factor + Cable Loss – Peramplifier Factor.

The following test results were performed on the EUT.

Test the EUT in transmitting mode.

Horizontal.

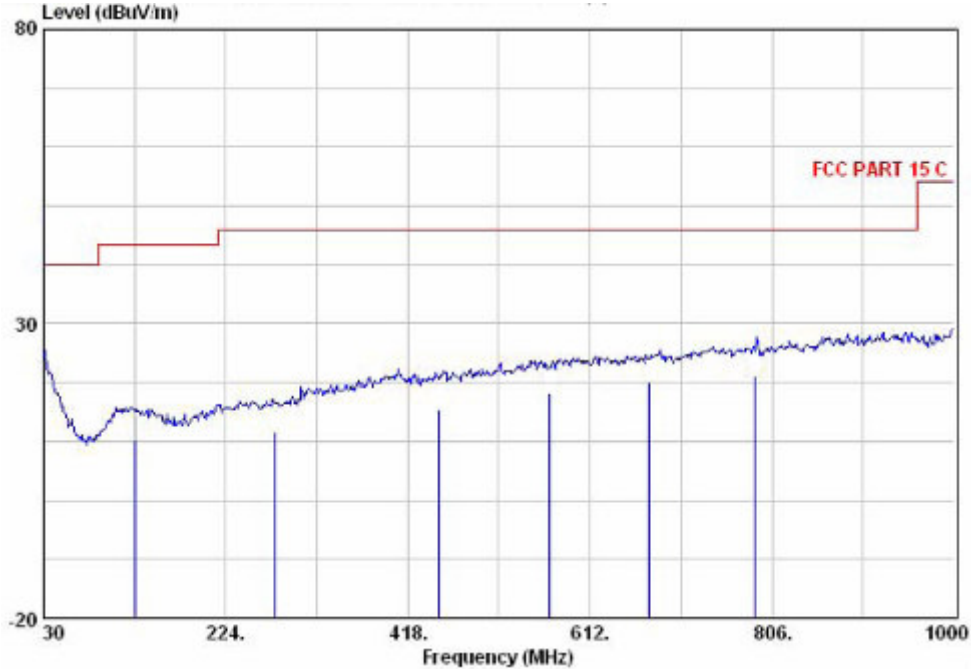

measure result:

Freq	Read Level	Antenna Factor	Cable Loss	Preamp Factor	Level	Limit	Over	Remark
MHz	dBuV	dB/m	dB	dB	dBuV/m	dBuV/m	dB	
127.970	21.72	12.32	1.30	25.10	10.24	43.50	-33.26	QP
276.380	21.64	12.32	2.00	24.40	11.56	46.00	-34.44	QP
450.980	22.34	16.04	2.61	25.49	15.50	46.00	-30.50	QP
569.320	23.26	18.11	3.00	25.83	18.54	46.00	-27.46	QP
675.050	24.04	18.60	3.25	25.72	20.17	46.00	-25.83	QP
788.540	23.46	19.78	3.58	25.61	21.22	46.00	-24.78	QP

Remark: : 1. All readings are Quasi-peak values.
: 2. Level = Read Level + Antenna Factor +
: Cable Loss - Preamp Factor

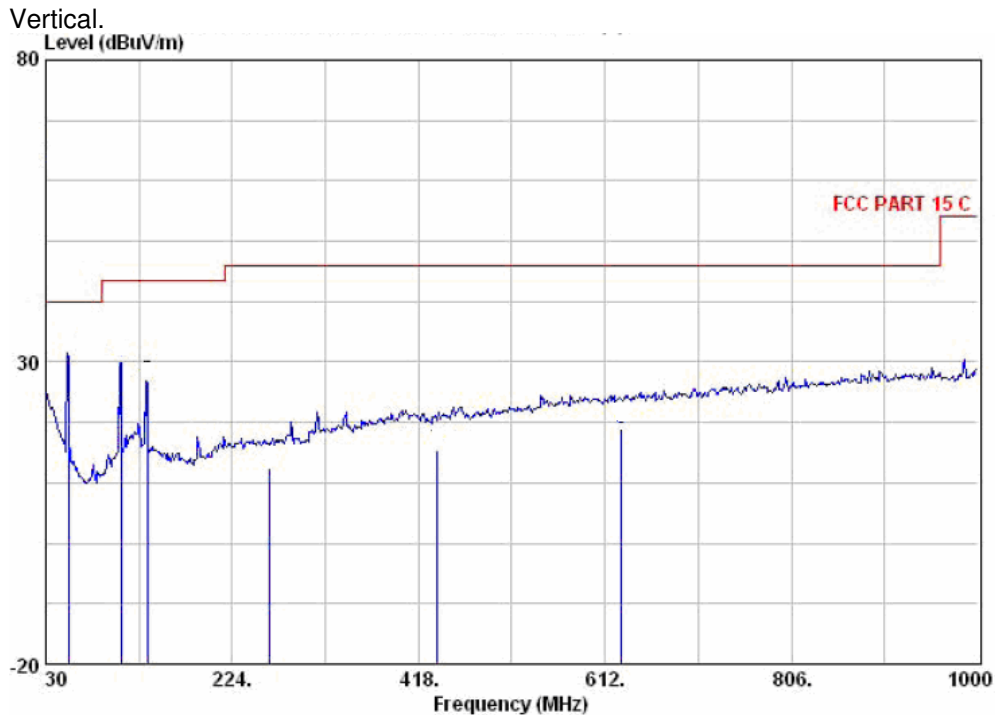

measure result:

Freq	ReadAntenna Level	Antenna Factor	Cable Loss	Preamp Factor	Level	Limit Line	Over Limit	Remark
MHz	dBuV	dB/m	dB	dB	dBuV/m	dBuV/m	dB	
108.590	42.05	11.94	1.20	25.10	30.09	43.50	-13.41	QP
135.770	38.87	11.78	1.30	25.10	26.85	43.50	-16.65	QP
262.800	22.91	11.94	1.93	24.40	12.38	46.00	-33.62	QP
436.430	22.37	15.83	2.56	25.36	15.40	46.00	-30.60	QP
629.460	23.02	18.51	3.10	25.77	18.86	46.00	-27.14	QP

Remark:

According to 15.35 (b) When average radiated emission measurements are specified in the regulations, including emission measurements below 1000 MHz, there is also a limit on the radio frequency emissions, as measured using instrumentation with a peak detector function, corresponding to 20 dB above the maximum permitted average limit for the frequency being investigated unless a different peak emission limit is otherwise specified in the rules, e.g., see Section 15.255.

Test Results: The unit does meet the FCC requirements.

6.3 Occupied Bandwidth

Test Requirement:	FCC Part 15 C Section 15.215 (C) and Section 15.227.
Test Method:	ANSI C63.4
Test Date:	October 17, 2008
Requirements:	15.215(c), Intentional radiators operating under the alternative provisions to the general emission limits, as contained in §§ 15.217 through 15.257 and in subpart E of this part, must be designed to ensure that the 20 dB bandwidth of the emission is contained within the frequency band designated in the rule section under which the equipment is operated. The requirement to contain the 20 dB bandwidth of the emission within the specified frequency band includes the effects from frequency sweeping, frequency hopping and other modulation techniques that may be employed as well as the frequency stability of the transmitter over expected variations in temperature and supply voltage. If a frequency stability is not specified in the regulations, it is recommended that the fundamental emission be kept within at least the central 80% of the permitted band in order to minimize the possibility of out-of-band operation.
	Operation within the band 26.960 – 27.280 MHz
Method of measurement:	The useful radiated emission from the EUT was detected by the spectrum analyser with peak detector. The vertical Scale is set to 10dB per division. The horizontal scale is set to 32KHz per division. Record the 20 dB bandwidth of the carrier.

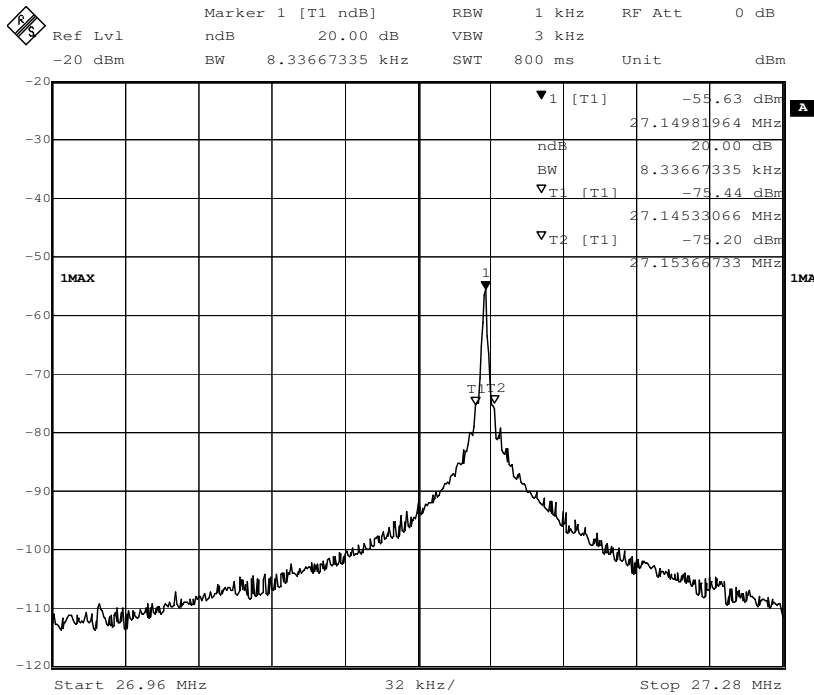

Date: 28.OCT.2008 12:54:29

20dB bandwidth lower frequency : 27.14533066MHz

20dB bandwidth upper frequency : 27.15366733MHz

The results: The unit does meet the FCC requirements

-----The End of the Report-----