



# FCC TEST REPORT (15.407)

**REPORT NO.:** RF980922L13A-1

**MODEL NO.:** ZF7731

**RECEIVED:** Sep. 22 2009

**TESTED:** Sep. 24 ~ Oct. 20, 2009

**ISSUED:** Oct. 26, 2009

<b>Applicant's Company</b>	Senao Networks, Inc.
<b>Applicant Address</b>	3F, No. 529, Chung Cheng Rd., Hsintien, Taipei, Taiwan
<b>FCC ID</b>	U2M-ZF7731
<b>Manufacturer's Company</b>	Senao Networks, Inc.
<b>Manufacturer Address</b>	3F, No. 529, Chung Cheng Rd., Hsintien, Taipei, Taiwan

**ISSUED BY:** Bureau Veritas Consumer Products Services (H.K.) Ltd., Taoyuan Branch

**LAB LOCATION:** No. 47, 14th Ling, Chia Pau Tsuen, Lin Kou Hsiang, Taipei Hsien, 244 Taiwan

This test report consists of 176 pages in total. It may be duplicated completely for legal use with the approval of the applicant. It should not be reproduced except in full, without the written approval of our laboratory. The client should not use it to claim product endorsement by TAF or any government agencies. The test results in the report only apply to the tested sample.





A D T

## TABLE OF CONTENTS

1.	CERTIFICATION .....	4
2.	SUMMARY OF TEST RESULTS .....	5
2.1	MEASUREMENT UNCERTAINTY .....	5
3.	GENERAL INFORMATION .....	6
3.1	GENERAL DESCRIPTION OF EUT .....	6
3.2	DESCRIPTION OF TEST MODES .....	8
3.2.1	CONFIGURATION OF SYSTEM UNDER TEST .....	10
3.2.2	TEST MODE APPLICABILITY AND TESTED CHANNEL DETAIL .....	14
3.3	GENERAL DESCRIPTION OF APPLIED STANDARDS .....	18
3.4	DESCRIPTION OF SUPPORT UNITS .....	18
4.	TEST TYPES AND RESULTS .....	19
4.1	RADIATED EMISSION MEASUREMENT .....	19
4.1.1	LIMITS OF RADIATED EMISSION MEASUREMENT .....	19
4.1.2	LIMITS OF UNWANTED EMISSION OUT OF THE RESTRICTED BANDS .....	19
4.1.3	TEST INSTRUMENTS .....	20
4.1.4	TEST PROCEDURES .....	21
4.1.5	DEVIATION FROM TEST STANDARD .....	21
4.1.6	TEST SETUP .....	22
4.1.7	EUT OPERATING CONDITION .....	22
4.1.8	TEST RESULT .....	23
4.2	CONDUCTED EMISSION MEASUREMENT .....	65
4.2.1	LIMITS OF CONDUCTED EMISSION MEASUREMENT .....	65
4.2.2	TEST INSTRUMENTS .....	65
4.2.3	TEST PROCEDURES .....	66
4.2.4	DEVIATION FROM TEST STANDARD .....	66
4.2.5	TEST SETUP .....	67
4.2.6	EUT OPERATING CONDITIONS .....	67
4.2.7	TEST RESULTS .....	68
4.3	MAXIMUM CONDUCTED OUTPUT POWER MEASUREMENT .....	84
4.3.1	LIMITS OF MAXIMUM CONDUCTED OUTPUT POWER MEASUREMENT .....	84
4.3.2	TEST INSTRUMENTS .....	84
4.3.3	TEST PROCEDURES .....	85
4.3.4	DEVIATION FROM TEST STANDARD .....	85
4.3.5	TEST SETUP .....	85
4.3.6	EUT OPERATING CONDITIONS .....	85
4.3.7	TEST RESULTS .....	86
4.4	PEAK POWER EXCURSION MEASUREMENT .....	98
4.4.1	LIMITS OF PEAK POWER EXCURSION MEASUREMENT .....	98
4.4.2	TEST INSTRUMENTS .....	98
4.4.3	TEST PROCEDURE .....	98
4.4.4	DEVIATION FROM TEST STANDARD .....	99



A D T

4.4.5	TEST SETUP.....	99
4.4.6	EUT OPERATING CONDITIONS .....	99
4.4.7	TEST RESULTS .....	100
4.5	PEAK POWER SPECTRAL DENSITY MEASUREMENT .....	112
4.5.1	LIMITS OF PEAK POWER SPECTRAL DENSITY MEASUREMENT .....	112
4.5.2	TEST INSTRUMENTS.....	112
4.5.3	TEST PROCEDURES .....	112
4.5.4	DEVIATION FROM TEST STANDARD.....	113
4.5.5	TEST SETUP.....	113
4.5.6	EUT OPERATING CONDITIONS .....	113
4.5.7	TEST RESULTS .....	114
4.6	FREQUENCY STABILITY .....	120
4.6.1	LIMITS OF FREQUENCY STABILITY MEASUREMENT .....	120
4.6.2	TEST INSTRUMENTS.....	120
4.6.3	TEST PROCEDURE.....	120
4.6.4	DEVIATION FROM TEST STANDARD.....	121
4.6.5	TEST SETUP.....	121
4.6.6	EUT OPERATING CONDITION.....	121
4.6.7	TEST RESULTS .....	122
4.7	BAND EDGES MEASUREMENT .....	124
4.7.1	TEST INSTRUMENTS.....	124
4.7.2	TEST PROCEDURE.....	125
4.7.3	EUT OPERATING CONDITION.....	125
4.7.4	TEST RESULTS .....	126
5.	PHOTOGRAPHS OF THE TEST CONFIGURATION .....	174
6.	INFORMATION ON THE TESTING LABORATORIES.....	175
7.	APPENDIX A - MODIFICATIONS RECORDERS FOR ENGINEERING CHANGES TO THE EUT BY THE LAB.....	176



## 1. CERTIFICATION

**PRODUCT:** Zone Flex 7731 802.11n Industrial Point to Point Bridge  
**MODEL NO.:** ZF7731  
**BRAND:** Ruckus  
**APPLICANT:** Senao Networks Inc.  
**TEST SAMPLE:** ENGINEERING SAMPLE  
**TESTED:** Sep. 24 ~ Oct. 20, 2009  
**STANDARDS:** FCC Part 15, Subpart E (Section 15.407)  
ANSI C63.4-2003

The above equipment has been tested by **Bureau Veritas Consumer Products Services (H.K.) Ltd., Taoyuan Branch**, and found compliance with the requirement of the above standards. The test record, data evaluation & Equipment Under Test (EUT) configurations represented herein are true and accurate accounts of the measurements of the sample's EMC characteristics under the conditions specified in this report.

**PREPARED BY :** Annie Chang , **DATE:** Oct. 26, 2009  
( Annie Chang / Senior Specialist )

**TECHNICAL ACCEPTANCE :** Jamison Chan , **DATE:** Oct. 26, 2009  
Responsible for RF ( Jamison Chan / Supervisor )

**APPROVED BY :** Ken Liu , **DATE:** Oct. 26, 2009  
( Ken Liu / Assistant Manager )



A D T

## 2. SUMMARY OF TEST RESULTS

The EUT has been tested according to the following specifications:

APPLIED STANDARD: FCC PART 15, SUBPART E (SECTION 15.407)			
STANDARD SECTION	TEST TYPE AND LIMIT	RESULT	REMARK
15.407(b)(5)	AC Power Conducted Emission	PASS	Meet the requirement of limit. Minimum passing margin is -3.16dB at 10.477MHz.
15.407(b)(1/2/3) (b)(5)	Electric Field Strength Spurious Emissions, 30MHz ~ 40000MHz	PASS	Meet the requirement of limit. Minimum passing margin is -0.1dB at 250.00MHz.
15.407(a)(1/2/3)	Peak Transmit Power	PASS	Meet the requirement of limit.
15.407(a)(6)	Peak Power Excursion	PASS	Meet the requirement of limit.
15.407(a)(1/2/3)	Peak Power Spectral Density	PASS	Meet the requirement of limit.
15.407(g)	Frequency Stability	PASS	Meet the requirement of limit.
15.203	Antenna Requirement	PASS	<b>INTERNAL ANTENNA:</b> Antenna connector is U.FL not a standard connector. <b>EXTERNAL ANTENNA:</b> Antenna connector is N-Type.

### 2.1 MEASUREMENT UNCERTAINTY

Where relevant, the following measurement uncertainty levels have been estimated for tests performed on the EUT as specified in CISPR 16-4-2:

This uncertainty represents an expanded uncertainty expressed at approximately the 95% confidence level using a coverage factor of  $k = 2$ .

MEASUREMENT	FREQUENCY	UNCERTAINTY
Conducted emissions	150kHz~30MHz	2.44 dB
Radiated emissions	30MHz~1GHz	3.78 dB
	Above 1GHz	2.89 dB



A D T

### 3. GENERAL INFORMATION

#### 3.1 GENERAL DESCRIPTION OF EUT

<b>PRODUCT</b>	Zone Flex 7731 802.11n Industrial Point to Point Bridge
<b>MODEL NO.</b>	ZF7731
<b>FCC ID</b>	U2M-ZF7731
<b>POWER SUPPLY</b>	12Vdc or 48Vdc
<b>MODULATION TYPE</b>	BPSK
<b>MODULATION TECHNOLOGY</b>	OFDM
<b>TRANSFER RATE</b>	802.11a: 54.0/ 48.0/ 36.0/ 24.0/ 18.0/ 12.0/ 9.0/ 6.0Mbps 802.11n: up to 270.0Mbps
<b>OPERATING FREQUENCY</b>	5260 ~ 5320MHz & 5500 ~ 5700MHz
<b>NUMBER OF CHANNEL</b>	5260 ~ 5320MHz: 4 for 802.11a, 802.11n (20MHz) 2 for 802.11n (40MHz) 5500 ~ 5700MHz: 11 for 802.11a, 802.11n (20MHz) 5 for 802.11n (40MHz)
<b>OUTPUT POWER</b>	38.6mW
<b>ANTENNA TYPE</b>	Refer to note below
<b>ANTENNA CONNECTOR</b>	Refer to note below
<b>I/O PORTS</b>	Refer to user's manual
<b>DATA CABLE</b>	NA
<b>ACCESSORY DEVICES</b>	PoE, adapter(for PoE use)

**NOTE:**

1. This report is prepared for FCC class II permissive change. The difference compared with the original report is adding frequency band from 5.26GHz to 5.32GHz and 5.50GHz to 5.70GHz by software.
2. The EUT was operated with following PoE:

<b>MODEL:</b>	NPE-5818at
---------------	------------

The adapter of PoE:

<b>BRAND:</b>	Ruckus
<b>MODEL:</b>	PA1024-4HE
<b>INPUT:</b>	100-240Vac, 50-60Hz, 0.5A
<b>OUTPUT:</b>	48Vdc, 0.42A
<b>POWER LINE:</b>	1.8m non-shielded cable with one core

3. The frequency bands used in this EUT are listed as follows:

Frequency Band (MHz)	5260~5320	5500~5700
802.11a	√	√
802.11n (20MHz)	√	√
802.11n (40MHz)	√	√

4. The EUT incorporates a MIMO function. Physically, the EUT provides two completed transmitters and two receivers.

MODULATION MODE	TX FUNCTION	
	INTERNAL ANTENNA	EXTERNAL ANTENNA
802.11a	2TX	2TX
802.11n (20MHz)	2TX	2TX
802.11n (40MHz)	2TX	2TX

5. The internal and external works separately. In user FW, when external antenna plug in, the major transmission would program from external antenna. Two antennas will not transmit simultaneously. It was controlled by user FW.

6. The following antennas were applied to the EUT:

ITEM	TYPE	CONNECTOR	GAIN	OPTION
INTERNAL ANTENNA	Patch	U.FL	14dBi	X
EXTERNAL ANTENNA	Patch	N-Type	23dBi	Option

7. The EUT doesn't operate in 5600 ~ 5650MHz via software controls.

8. The above EUT information was declared by manufacturer and for more detailed features description, please refer to the manufacturer's specifications or user's manual.



### 3.2 DESCRIPTION OF TEST MODES

#### Operated in 5260 ~ 5320MHz

4 channels are provided for 802.11a, 802.11n (20MHz):

CHANNEL	FREQUENCY	CHANNEL	FREQUENCY
52	5260 MHz	60	5300 MHz
56	5280 MHz	64	5320 MHz

2 channels are provided for 802.11n (40MHz):

CHANNEL	FREQUENCY	CHANNEL	FREQUENCY
54	5270 MHz	62	5310 MHz

#### Operated in 5500 ~ 5700MHz

11 channels are provided for 802.11a, 802.11n (20MHz):

CHANNEL	FREQUENCY	CHANNEL	FREQUENCY
100	5500 MHz	124	5620 MHz
104	5520 MHz	128	5640 MHz
108	5540 MHz	132	5660 MHz
112	5560 MHz	136	5680 MHz
116	5580 MHz	140	5700 MHz
120	5600 MHz		

5 channels are provided for 802.11n (40MHz):

CHANNEL	FREQUENCY	CHANNEL	FREQUENCY
102	5510 MHz	126	5630 MHz
110	5550 MHz	134	5670 MHz
118	5690 MHz		





**Power Setting for 802.11a, 802.11n (20MHz):**

FOR MODE A			FOR MODE C		
CHANNEL		POWER SETTING	CHANNEL		POWER SETTING
52	Chain 0	14.0	52	Chain 0	3.5
	Chain 1	14.0		Chain 1	3.5
60	Chain 0	14.0	60	Chain 0	3.5
	Chain 1	14.0		Chain 1	3.5
64	Chain 0	8.0	64	Chain 0	0.5
	Chain 1	8.0		Chain 1	0.5
100	Chain 0	11.0	100	Chain 0	4.0
	Chain 1	11.0		Chain 1	4.0
120	Chain 0	13.5	120	Chain 0	3.0
	Chain 1	13.5		Chain 1	3.0
140	Chain 0	12.0	140	Chain 0	3.0
	Chain 1	12.0		Chain 1	3.0

**Power Setting for 802.11n (40MHz):**

FOR MODE A			FOR MODE C		
CHANNEL		POWER SETTING	CHANNEL		POWER SETTING
54	Chain 0	14.0	54	Chain 0	3.5
	Chain 1	14.0		Chain 1	3.5
62	Chain 0	8.0	62	Chain 0	0.5
	Chain 1	8.0		Chain 1	0.5
102	Chain 0	11.0	102	Chain 0	4.0
	Chain 1	11.0		Chain 1	4.0
118	Chain 0	13.5	118	Chain 0	3.0
	Chain 1	13.5		Chain 1	3.0
134	Chain 0	12.0	134	Chain 0	3.0
	Chain 1	12.0		Chain 1	3.0

### 3.2.1 CONFIGURATION OF SYSTEM UNDER TEST

#### Mode A:

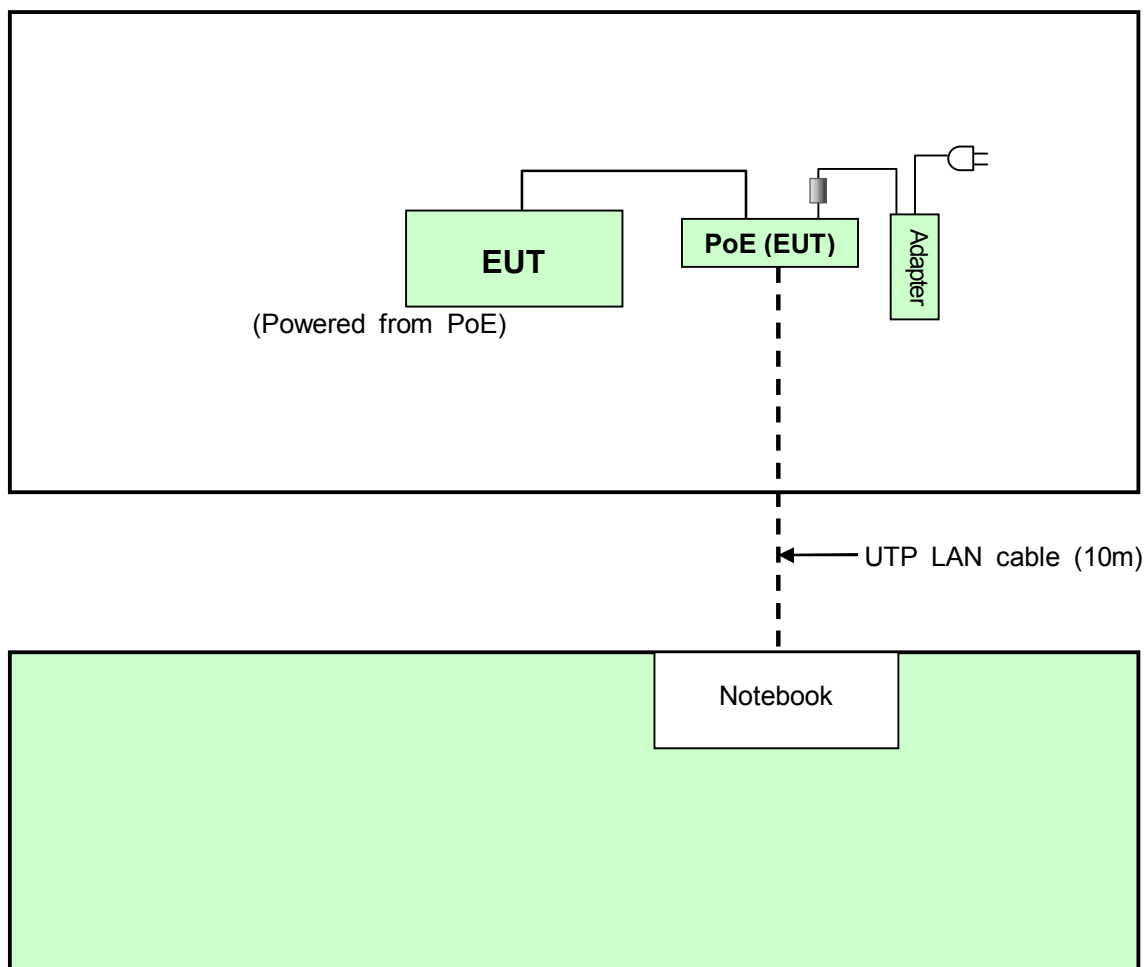

**Mode B:**

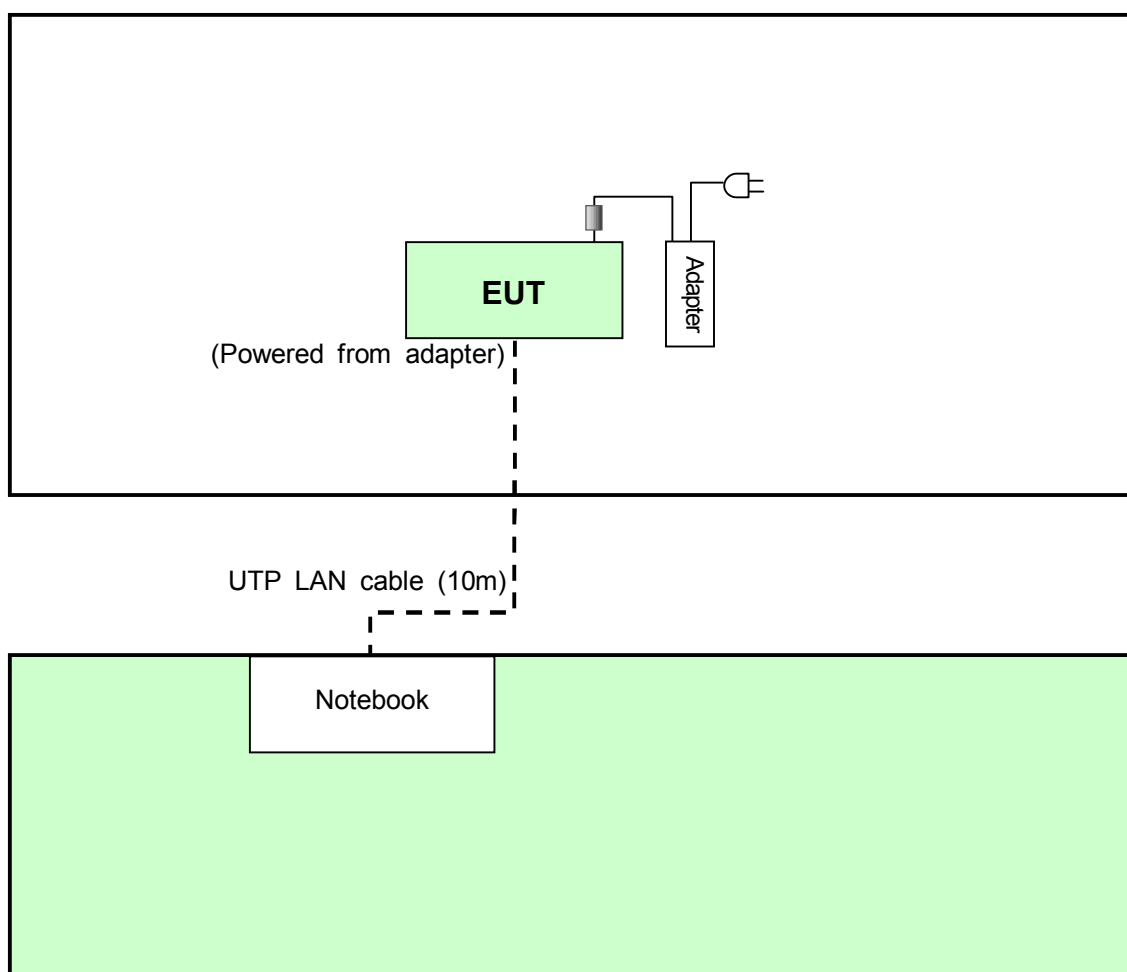

**Mode C:**

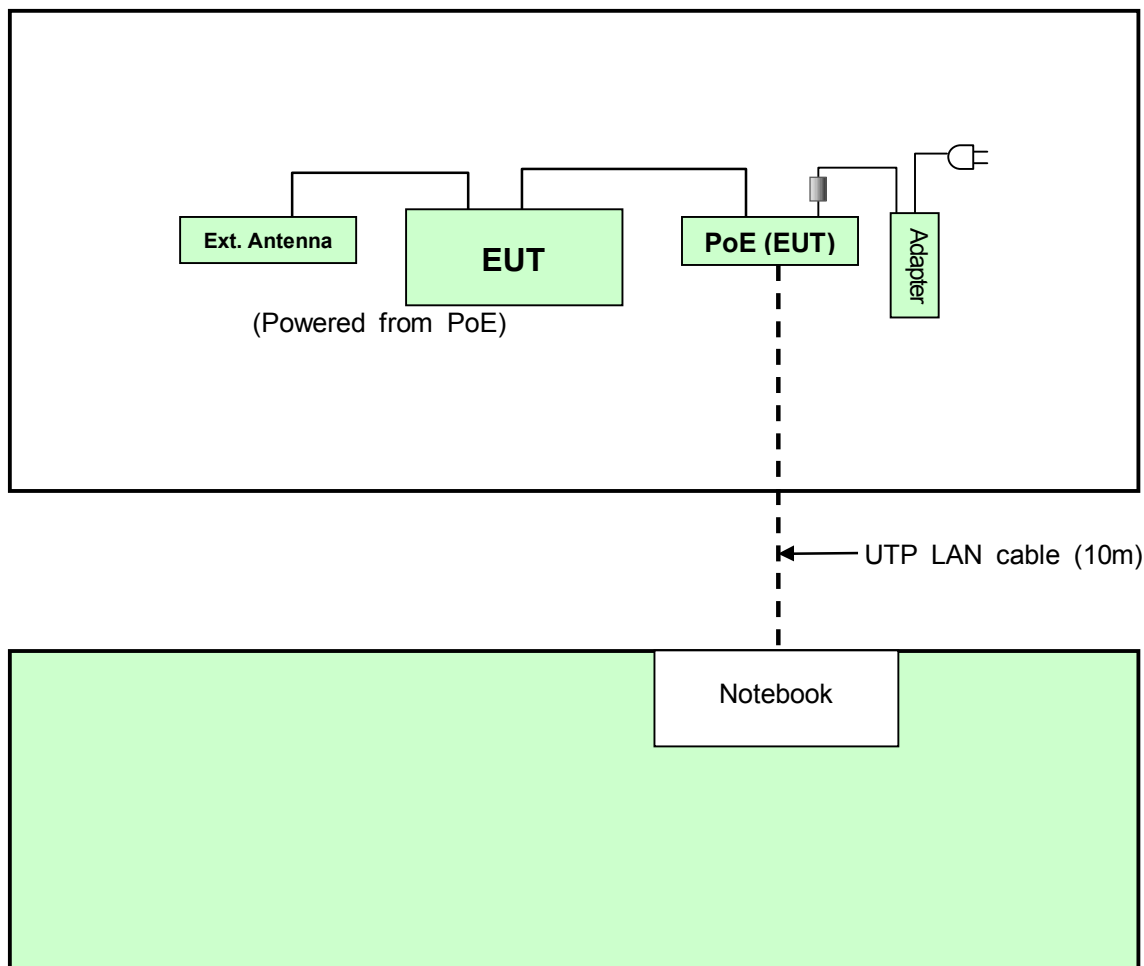

Mode D:

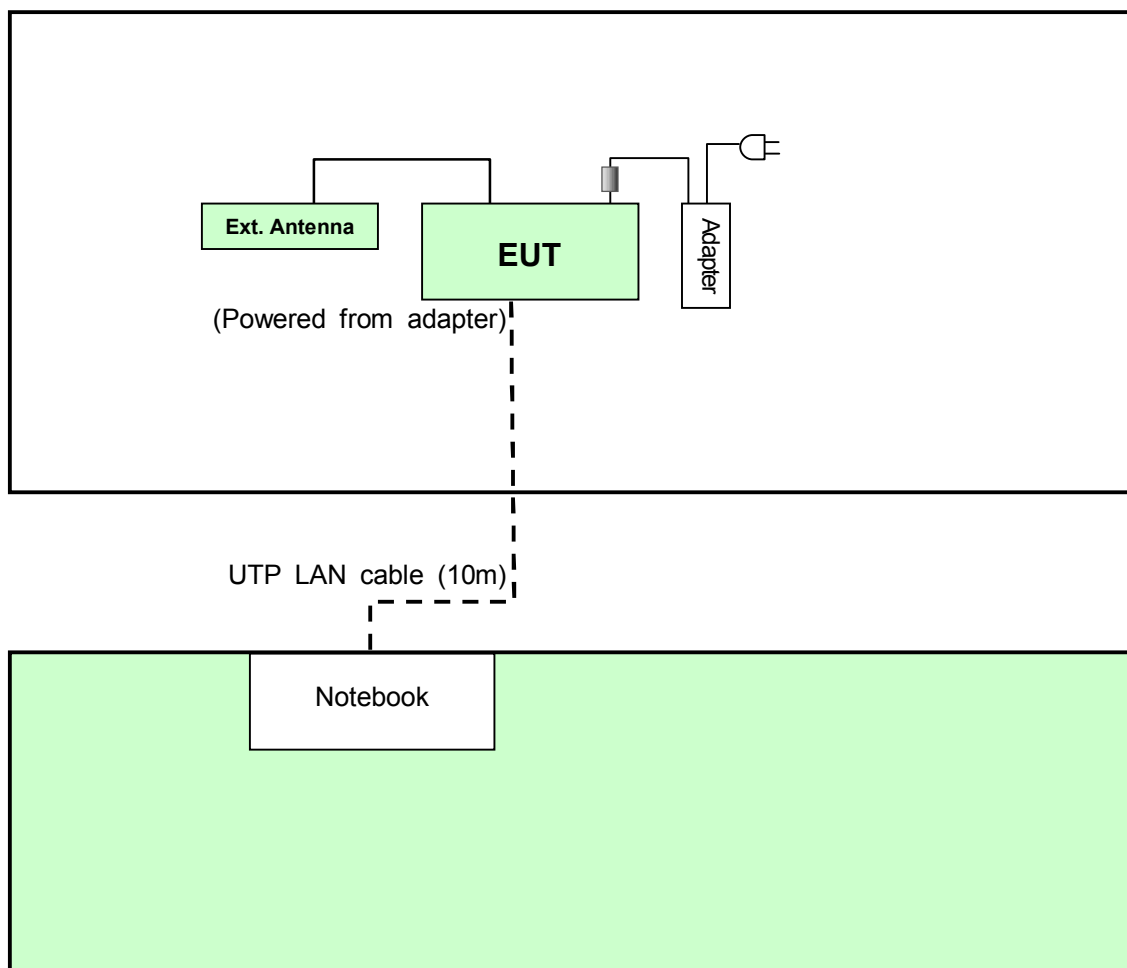

### 3.2.2 TEST MODE APPLICABILITY AND TESTED CHANNEL DETAIL

EUT CONFIGURE MODE	APPLICABLE TO				DESCRIPTION	
	RE $\geq$ 1G	RE<1G	PLC	APCM	Antenna	Power Source
A	√	√	√	√	Internal	Powered from POE
B	-	√	√	-		Powered from Adapter
C	√	√	√	√	External	Powered from POE
D	-	√	√	-		Powered from Adapter

Where **RE $\geq$ 1G**: Radiated Emission above 1GHz      **RE<1G**: Radiated Emission below 1GHz  
**PLC**: Power Line Conducted Emission      **APCM**: Antenna Port Conducted Measurement

**NOTE**: "-" means no effect.

#### **RADIATED EMISSION TEST (ABOVE 1GHz):**

- Pre-Scan has been conducted to determine the worst-case mode from all possible combinations between available modulations, data rates, XYZ axis and antenna ports (if EUT with antenna diversity architecture).
- Following channel(s) was (were) selected for the final test as listed below.

EUT CONFIGURE MODE	MODE	AVAILABLE CHANNEL	TESTED CHANNEL	MODULATION TECHNOLOGY	MODULATION TYPE	DATA RATE (Mbps)	AXIS
A	802.11a	52 to 64	52, 60, 64	OFDM	BPSK	6.0	Z
		100 to 140	100, 120, 140	OFDM	BPSK	6.0	Z
C		52 to 64	52, 60, 64	OFDM	BPSK	6.0	X
		100 to 140	100, 120, 140	OFDM	BPSK	6.0	X
A	802.11n (20MHz)	52 to 64	52, 60, 64	OFDM	BPSK	6.5	Z
		100 to 140	100, 120, 140	OFDM	BPSK	6.5	Z
C		52 to 64	52, 60, 64	OFDM	BPSK	6.5	X
		100 to 140	100, 120, 140	OFDM	BPSK	6.5	X
A	802.11n (40MHz)	54 to 62	54, 62	OFDM	BPSK	13.5	Z
		102 to 134	102, 118, 134	OFDM	BPSK	13.5	Z
C		54 to 62	54, 62	OFDM	BPSK	13.5	X
		102 to 134	102, 118, 134	OFDM	BPSK	13.5	X

**RADIATED EMISSION TEST (BELOW 1GHz):**

- Pre-Scan has been conducted to determine the worst-case mode from all possible combinations between available modulations, data rates, XYZ axis and antenna ports (if EUT with antenna diversity architecture).
- Following channel(s) was (were) selected for the final test as listed below.

EUT CONFIGURE MODE	MODE	AVAILABLE CHANNEL	TESTED CHANNEL	MODULATION TECHNOLOGY	MODULATION TYPE	DATA RATE (Mbps)	AXIS
A & B	802.11n (20MHz)	52 to 64	64	OFDM	BPSK	6.5	Z
		100 to 140	100	OFDM	BPSK	6.5	Z
C & D		52 to 64	64	OFDM	BPSK	6.5	X
		100 to 140	100	OFDM	BPSK	6.5	X

**POWER LINE CONDUCTED EMISSION TEST:**

- Pre-Scan has been conducted to determine the worst-case mode from all possible combinations between available modulations, data rates and antenna ports (if EUT with antenna diversity architecture).
- Following channel(s) was (were) selected for the final test as listed below.

EUT CONFIGURE MODE	MODE	AVAILABLE CHANNEL	TESTED CHANNEL	MODULATION TECHNOLOGY	MODULATION TYPE	DATA RATE (Mbps)
A ~ D	802.11n (20MHz)	52 to 64	64	OFDM	BPSK	6.5
A ~ D	802.11n (20MHz)	100 to 140	100	OFDM	BPSK	6.5

**BANDEDGE MEASUREMENT:**

- Pre-Scan has been conducted to determine the worst-case mode from all possible combinations between available modulations, data rates, XYZ axis and antenna ports (if EUT with antenna diversity architecture).
- Following channel(s) was (were) selected for the final test as listed below.

EUT CONFIGURE MODE	MODE	AVAILABLE CHANNEL	TESTED CHANNEL	MODULATION TECHNOLOGY	MODULATION TYPE	DATA RATE (Mbps)	AXIS
A	802.11a	52 to 64	52, 64	OFDM	BPSK	6.0	Z
		100 to 140	100, 140	OFDM	BPSK	6.0	Z
C		52 to 64	52, 64	OFDM	BPSK	6.0	X
		100 to 140	100, 140	OFDM	BPSK	6.0	X
A	802.11n (20MHz)	52 to 64	52, 64	OFDM	BPSK	6.5	Z
		100 to 140	100, 140	OFDM	BPSK	6.5	Z
C		52 to 64	52, 64	OFDM	BPSK	6.5	X
		100 to 140	100, 140	OFDM	BPSK	6.5	X
A	802.11n (40MHz)	54 to 62	54, 62	OFDM	BPSK	13.5	Z
		102 to 134	102, 134	OFDM	BPSK	13.5	Z
C		54 to 62	54, 62	OFDM	BPSK	13.5	X
		102 to 134	102, 134	OFDM	BPSK	13.5	X



**ANTENNA PORT CONDUCTED MEASUREMENT:**

- This item includes all test value of each mode, but only includes spectrum plot of worst value of each mode.
- Pre-Scan has been conducted to determine the worst-case mode from all possible combinations between available modulations, data rates and antenna ports (if EUT with antenna diversity architecture).
- Following channel(s) was (were) selected for the final test as listed below.

EUT CONFIGURE MODE	MODE	AVAILABLE CHANNEL	TESTED CHANNEL	MODULATION TECHNOLOGY	MODULATION TYPE	DATA RATE (Mbps)
A	802.11a	52 to 64	52, 60, 64	OFDM	BPSK	6.0
		100 to 140	100, 120, 140	OFDM	BPSK	6.0
C		52 to 64	52, 60, 64	OFDM	BPSK	6.0
		100 to 140	100, 120, 140	OFDM	BPSK	6.0
A	802.11n (20MHz)	52 to 64	52, 60, 64	OFDM	BPSK	6.5
		100 to 140	100, 120, 140	OFDM	BPSK	6.5
C		52 to 64	52, 60, 64	OFDM	BPSK	6.5
		100 to 140	100, 120, 140	OFDM	BPSK	6.5
A	802.11n (40MHz)	54 to 62	54, 62	OFDM	BPSK	13.5
		102 to 134	102, 118, 134	OFDM	BPSK	13.5
C		54 to 62	54, 62	OFDM	BPSK	13.5
		102 to 134	102, 118, 134	OFDM	BPSK	13.5

**TEST CONDITION:**

APPLICABLE TO	ENVIRONMENTAL CONDITIONS	INPUT POWER (SYSTEM)	TESTED BY
RE $\geq$ 1G	28deg. C, 75% RH, 1009hPa	120Vac, 60Hz	Chad Lee
RE $<$ 1G	23deg. C, 76% RH, 1010hPa	120Vac, 60Hz	Chad Lee
PLC	25deg. C, 72% RH, 1011hPa	120Vac, 60Hz	Chad Lee
APCM	25deg. C, 65% RH, 1008hPa	120Vac, 60Hz	Chad Lee



A D T

### 3.3 GENERAL DESCRIPTION OF APPLIED STANDARDS

The EUT is a RF Product. According to the specifications of the manufacturer, it must comply with the requirements of the following standards:

**Canada RSS-210 Issue 7 (June 2007)**

**Canada RSS-Gen Issue 2 (June 2007)**

**ANSI C63.4-2003**

All test items have been performed and recorded as per the above standards.

### 3.4 DESCRIPTION OF SUPPORT UNITS

The EUT has been tested as an independent unit together with other necessary accessories or support units. The following support units or accessories were used to form a representative test configuration during the tests.

NO.	PRODUCT	BRAND	MODEL NO.	SERIAL NO.	FCC ID
1	Adapter	AMIGO	AM-121000	NA	NA
2	NOTEBOOK COMPUTER	DELL	PP05L	20375526736	FCC DoC Approved

NO.	SIGNAL CABLE DESCRIPTION OF THE ABOVE SUPPORT UNITS
1	NA
2	10m RJ45 cable

- NOTE:** 1. All power cords of the above support units are non shielded (1.8m).  
2. Item 2 acted as communication partners to transfer data.  
3. The support unit 1 was provided by client.



#### 4. TEST TYPES AND RESULTS

##### 4.1 RADIATED EMISSION MEASUREMENT

###### 4.1.1 LIMITS OF RADIATED EMISSION MEASUREMENT

Emissions radiated outside of the specified bands, shall be according to the general radiated limits in 15.209 as following:

FREQUENCIES (MHz)	FIELD STRENGTH (microvolts/meter)	MEASUREMENT DISTANCE (meters)
0.009 ~ 0.490	2400/F(kHz)	300
0.490 ~ 1.705	24000/F(kHz)	30
1.705 ~ 30.0	30	30
30 ~ 88	100	3
88 ~ 216	150	3
216 ~ 960	200	3
Above 960	500	3

**NOTE:**

1. The lower limit shall apply at the transition frequencies.
2. Emission level (dBuV/m) = 20 log Emission level (uV/m).
3. As shown in 15.35(b), for frequencies above 1000MHz, the field strength limits are based on average detector, however, the peak field strength of any emission shall not exceed the maximum permitted average limits, specified above by more than 20dB under any condition of modulation.

###### 4.1.2 LIMITS OF UNWANTED EMISSION OUT OF THE RESTRICTED BANDS

FREQUENCIES (MHz)	EIRP LIMIT (dBm)	EQUIVALENT FIELD STRENGTH AT 3m (dBµV/m) *NOTE	
	AV	PK	AV
5150 ~ 5350	-27	88.3	68.3
5470 ~ 5725	-27	88.3	68.3

**NOTE:**

The following formula is used to convert the equipment isotropic radiated power (eirp) to field strength:

$$E = \frac{1000000\sqrt{30P}}{3} \mu\text{V/m, where P is the eirp (Watts).$$



#### 4.1.3 TEST INSTRUMENTS

##### <Frequency Range 30MHz~1GHz>

DESCRIPTION & MANUFACTURER	MODEL NO.	SERIAL NO.	CALIBRATED DATE	CALIBRATED UNTIL
ROHDE & SCHWARZ TEST RECEIVER	ESVS 30	841977/008	Apr. 24, 2009	Apr. 23, 2010
SCHAFFNER BILOG Antenna	CBL6111C	2793	Apr. 29, 2009	Apr. 28, 2010
ADT. Turn Table	TT100	0201	NA	NA
ADT. Tower	AT100	0201	NA	NA
Software	ADT_Radiate d_V7.6.15.9.2	NA	NA	NA
ADT RF Switches BOX	EM-H-01-1	1004	Dec. 19, 2008	Dec. 18, 2009
WOKEN RF cable	8D	CABLE-ST10-01	Dec. 19, 2008	Dec. 18, 2009

- NOTE:**
1. The calibration interval of the above test instruments is 12 months. And the calibrations are traceable to NML/ROC and NIST/USA.
  2. The test was performed in Open Site No. 10.
  3. The VCCI Site Registration No. R-1625.
  4. The Industry Canada Reference No. IC 7450E-10.
  5. The FCC Site Registration No. 698148.

##### <Frequency Range above 1GHz>

DESCRIPTION & MANUFACTURER	MODEL NO.	SERIAL NO.	CALIBRATED DATE	CALIBRATED UNTIL
Agilent Spectrum	8564EC	4208A00659	Jul. 24, 2009	Jul. 23, 2010
Agilent Preamplifier	8449B	3008A01924	Aug. 31, 2009	Aug. 30, 2010
Agilent Preamplifier	8449B	3008A01292	Aug. 10, 2009	Aug. 09, 2010
MITEQ Preamplifier	AMF-6F-2604 00-33-8P	892164	Aug. 31, 2009	Aug. 30, 2010
Schwarzbeck Horn Antenna	BBHA-9170	BBHA9170190	Sep. 24, 2009	Sep. 23, 2010
Schwarzbeck Horn Antenna	BBHA-9120	D130	May 15, 2009	May 14, 2010
ADT. Turn Table	TT100	0201	NA	NA
ADT. Tower	AT100	0201	NA	NA
Software	ADT_Radiate d_V7.6.15.9.2	NA	NA	NA
SUHNER RF cable	SF106-18	PHACAB-1G-40 GHZ	Aug. 20, 2009	Aug. 19, 2010

- NOTE:**
1. The calibration interval of the above test instruments is 12 months. And the calibrations are traceable to NML/ROC and NIST/USA.
  2. The test was performed in Open Site No. 10.
  3. The Industry Canada Reference No. IC 7450E-10.
  4. The FCC Site Registration No. 698148.

#### 4.1.4 TEST PROCEDURES

- a. The EUT was placed on the top of a rotating table 0.8 meters above the ground at a 10-meter open area test site. The table was rotated 360 degrees to determine the position of the highest radiation.
- b. The EUT was set 3 meters away from the interference-receiving antenna, which was mounted on the top of a variable-height antenna tower.
- c. The antenna is a broadband antenna, and its height is varied from one meter to four meters above the ground to determine the maximum value of the field strength. Both horizontal and vertical polarizations of the antenna are set to make the measurement.
- d. For each suspected emission, the EUT was arranged to its worst case and then the antenna was tuned to heights from 1 meter to 4 meters and the rotatable table was turned from 0 degrees to 360 degrees to find the maximum reading.
- e. The test-receiver system was set to Peak Detect Function and Specified Bandwidth with Maximum Hold Mode.
- f. If the emission level of the EUT in peak mode was 10dB lower than the limit specified, then testing could be stopped and the peak values of the EUT would be reported. Otherwise the emissions that did not have 10dB margin would be re-tested one by one using peak, quasi-peak or average method as specified and then reported in a data sheet.

**NOTE:**

1. The resolution bandwidth and video bandwidth of test receiver/spectrum analyzer is 120kHz for Peak detection (PK) and Quasi-peak detection (QP) at frequency below 1GHz.
2. The resolution bandwidth of test receiver/spectrum analyzer is 1MHz and video bandwidth is 3MHz for Peak detection at frequency above 1GHz.
3. The resolution bandwidth of test receiver/spectrum analyzer is 1MHz and the video bandwidth is 10Hz for Average detection (AV) at frequency above 1GHz.
4. All modes of operation were investigated and the worst-case emissions are reported.

#### 4.1.5 DEVIATION FROM TEST STANDARD

No deviation

#### 4.1.6 TEST SETUP

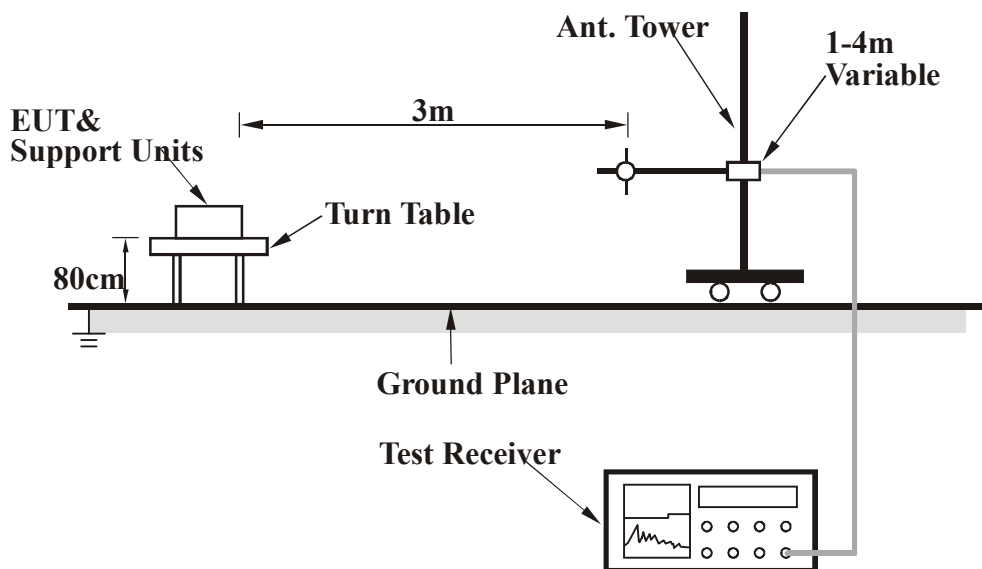

For the actual test configuration, please refer to the attached file (Test Setup Photo).

#### 4.1.7 EUT OPERATING CONDITION

- a. Placed the EUT on the testing table.
- b. Prepared a notebook system to act as communication partners and placed them outside of testing area.
- c. The communication partners run a test program (provided by manufacturer) to enable EUT under transmission condition continuously at specific channel frequency via RJ45 cables.

## 4.1.8 TEST RESULT

### 802.11a

EUT TEST CONDITION		MEASUREMENT DETAIL	
CHANNEL	Channel 52	FREQUENCY RANGE	1 ~ 40GHz
INPUT POWER	120Vac, 60Hz	DETECTOR FUNCTION	Peak (PK) Average (AV)
ENVIRONMENTAL CONDITIONS	28deg. C, 75%R H 1009hPa	TESTED BY	Chad Lee
TEST MODE	A		

ANTENNA POLARITY & TEST DISTANCE: HORIZONTAL AT 3 M								
NO.	FREQ. (MHz)	EMISSION LEVEL (dBuV/m)	LIMIT (dBuV/m)	MARGIN (dB)	ANTENNA HEIGHT (m)	TABLE ANGLE (Degree)	RAW VALUE (dBuV)	CORRECTION FACTOR (dB/m)
1	5150.00	50.3 PK	74.0	-23.7	1.00 H	2	11.96	38.35
2	5150.00	38.0 AV	54.0	-16.0	1.00 H	2	-0.34	38.35
3	*5260.00	120.4 PK			1.00 H	2	81.83	38.52
4	*5260.00	110.5 AV			1.00 H	2	71.95	38.52
5	#10520.00	61.3 PK	88.3	-27.0	1.00 H	354	11.93	49.33
ANTENNA POLARITY & TEST DISTANCE: VERTICAL AT 3 M								
NO.	FREQ. (MHz)	EMISSION LEVEL (dBuV/m)	LIMIT (dBuV/m)	MARGIN (dB)	ANTENNA HEIGHT (m)	TABLE ANGLE (Degree)	RAW VALUE (dBuV)	CORRECTION FACTOR (dB/m)
1	5150.00	50.3 PK	74.0	-23.8	1.00 V	358	11.90	38.35
2	5150.00	38.1 AV	54.0	-16.0	1.00 V	358	-0.30	38.35
3	*5260.00	121.6 PK			1.00 V	358	83.11	38.52
4	*5260.00	111.3 AV			1.00 V	358	72.80	38.52
5	#10520.00	59.0 PK	88.3	-29.3	1.07 V	86	9.66	49.33

- REMARKS:**
1. Emission level (dBuV/m) = Raw Value (dBuV) + Correction Factor (dB/m).
  2. Correction Factor (dB/m) = Antenna Factor (dB/m) + Cable Factor (dB).
  3. The other emission levels were very low against the limit.
  4. Margin value = Emission level – Limit value.
  5. “ \* “: Fundamental frequency.
  6. “#”:The radiated frequency is out the restricted band.



A D T

EUT TEST CONDITION		MEASUREMENT DETAIL	
CHANNEL	Channel 60	FREQUENCY RANGE	1 ~ 40GHz
INPUT POWER	120Vac, 60Hz	DETECTOR FUNCTION	Peak (PK) Average (AV)
ENVIRONMENTAL CONDITIONS	28deg. C, 75%R H 1009hPa	TESTED BY	Chad Lee
TEST MODE	A		

ANTENNA POLARITY & TEST DISTANCE: HORIZONTAL AT 3 M								
NO.	FREQ. (MHz)	EMISSION LEVEL (dBuV/m)	LIMIT (dBuV/m)	MARGIN (dB)	ANTENNA HEIGHT (m)	TABLE ANGLE (Degree)	RAW VALUE (dBuV)	CORRECTION FACTOR (dB/m)
1	*5300.00	120.4 PK			1.00 H	351	81.84	38.55
2	*5300.00	110.7 AV			1.00 H	350	72.16	38.55
3	10600.00	60.7 PK	74.0	-13.3	1.00 H	15	11.23	49.49
4	10600.00	49.1 AV	54.0	-4.9	1.00 H	15	-0.37	49.49
ANTENNA POLARITY & TEST DISTANCE: VERTICAL AT 3 M								
NO.	FREQ. (MHz)	EMISSION LEVEL (dBuV/m)	LIMIT (dBuV/m)	MARGIN (dB)	ANTENNA HEIGHT (m)	TABLE ANGLE (Degree)	RAW VALUE (dBuV)	CORRECTION FACTOR (dB/m)
1	*5300.00	121.9 PK			1.00 V	0	83.39	38.55
2	*5300.00	111.3 AV			1.00 V	0	72.70	38.55
3	10600.00	61.5 PK	74.0	-12.5	1.00 V	21	12.02	49.49
4	10600.00	48.1 AV	54.0	-5.9	1.00 V	21	-1.40	49.49

- REMARKS:**
1. Emission level (dBuV/m) = Raw Value (dBuV) + Correction Factor (dB/m).
  2. Correction Factor (dB/m) = Antenna Factor (dB/m) + Cable Factor (dB).
  3. The other emission levels were very low against the limit.
  4. Margin value = Emission level – Limit value.
  5. “ \* “: Fundamental frequency.





A D T

EUT TEST CONDITION		MEASUREMENT DETAIL	
CHANNEL	Channel 64	FREQUENCY RANGE	1 ~ 40GHz
INPUT POWER	120Vac, 60Hz	DETECTOR FUNCTION	Peak (PK) Average (AV)
ENVIRONMENTAL CONDITIONS	28deg. C, 75%R H 1009hPa	TESTED BY	Chad Lee
TEST MODE	A		

ANTENNA POLARITY & TEST DISTANCE: HORIZONTAL AT 3 M								
NO.	FREQ. (MHz)	EMISSION LEVEL (dBuV/m)	LIMIT (dBuV/m)	MARGIN (dB)	ANTENNA HEIGHT (m)	TABLE ANGLE (Degree)	RAW VALUE (dBuV)	CORRECTION FACTOR (dB/m)
1	*5320.00	115.7 PK			1.00 H	0	77.13	38.58
2	*5320.00	105.4 AV			1.00 H	0	66.79	38.58
3	5350.00	66.5 PK	74.0	-7.5	1.00 H	0	27.86	38.63
4	5350.00	48.0 AV	54.0	-6.0	1.00 H	0	9.36	38.63
5	10640.00	60.1 PK	74.0	-13.9	1.00 H	338	10.49	49.56
6	10640.00	47.1 AV	54.0	-6.9	1.00 H	338	-2.51	49.56
ANTENNA POLARITY & TEST DISTANCE: VERTICAL AT 3 M								
NO.	FREQ. (MHz)	EMISSION LEVEL (dBuV/m)	LIMIT (dBuV/m)	MARGIN (dB)	ANTENNA HEIGHT (m)	TABLE ANGLE (Degree)	RAW VALUE (dBuV)	CORRECTION FACTOR (dB/m)
1	*5320.00	116.5 PK			1.00 V	0	77.89	38.58
2	*5320.00	105.6 AV			1.00 V	0	67.01	38.58
3	5350.00	66.9 PK	74.0	-7.1	1.00 V	0	28.25	38.63
4	5350.00	48.2 AV	54.0	-5.8	1.00 V	0	9.53	38.63
5	10640.00	58.7 PK	74.0	-15.3	1.14 V	19	9.13	49.56
6	10640.00	46.5 AV	54.0	-7.5	1.14 V	19	-3.02	49.56

- REMARKS:**
1. Emission level (dBuV/m) = Raw Value (dBuV) + Correction Factor (dB/m).
  2. Correction Factor (dB/m) = Antenna Factor (dB/m) + Cable Factor (dB).
  3. The other emission levels were very low against the limit.
  4. Margin value = Emission level – Limit value.
  5. “ \* “: Fundamental frequency.



A D T

EUT TEST CONDITION		MEASUREMENT DETAIL	
CHANNEL	Channel 100	FREQUENCY RANGE	1 ~ 40GHz
INPUT POWER	120Vac, 60Hz	DETECTOR FUNCTION	Peak (PK) Average (AV)
ENVIRONMENTAL CONDITIONS	28deg. C, 75%R H 1009hPa	TESTED BY	Chad Lee
TEST MODE	A		

**ANTENNA POLARITY & TEST DISTANCE: HORIZONTAL AT 3 M**

NO.	FREQ. (MHz)	EMISSION LEVEL (dBuV/m)	LIMIT (dBuV/m)	MARGIN (dB)	ANTENNA HEIGHT (m)	TABLE ANGLE (Degree)	RAW VALUE (dBuV)	CORRECTION FACTOR (dB/m)
1	5460.00	61.4 PK	74.0	-12.6	1.00 H	0	22.60	38.84
2	5460.00	45.8 AV	54.0	-8.2	1.00 H	0	7.00	38.84
3	#5470.00	68.2 PK	88.3	-20.1	1.00 H	0	29.38	38.86
4	#5470.00	48.5 AV	68.3	-19.8	1.00 H	0	9.68	38.86
5	*5500.00	116.2 PK			1.00 H	0	77.25	38.92
6	*5500.00	104.3 AV			1.00 H	0	65.42	38.92
7	11000.00	64.8 PK	74.0	-9.2	1.00 H	89	14.47	50.29
8	11000.00	50.6 AV	54.0	-3.4	1.00 H	89	0.33	50.29

**ANTENNA POLARITY & TEST DISTANCE: VERTICAL AT 3 M**

NO.	FREQ. (MHz)	EMISSION LEVEL (dBuV/m)	LIMIT (dBuV/m)	MARGIN (dB)	ANTENNA HEIGHT (m)	TABLE ANGLE (Degree)	RAW VALUE (dBuV)	CORRECTION FACTOR (dB/m)
1	5460.00	61.4 PK	74.0	-12.6	1.00 V	359	22.56	38.84
2	5460.00	46.0 AV	54.0	-8.0	1.00 V	359	7.13	38.84
3	#5470.00	68.7 PK	88.3	-19.6	1.00 V	359	29.84	38.86
4	#5470.00	39.7 AV	68.3	-28.6	1.00 V	359	0.79	38.86
5	*5500.00	117.0 PK			1.00 V	359	78.09	38.92
6	*5500.00	105.0 AV			1.00 V	359	66.08	38.92
7	11000.00	61.9 PK	74.0	-12.1	1.00 V	62	11.56	50.29
8	11000.00	48.5 AV	54.0	-5.5	1.00 V	62	-1.79	50.29

- REMARKS:**
1. Emission level (dBuV/m) = Raw Value (dBuV) + Correction Factor (dB/m).
  2. Correction Factor (dB/m) = Antenna Factor (dB/m) + Cable Factor (dB).
  3. The other emission levels were very low against the limit.
  4. Margin value = Emission level – Limit value.
  5. “ \* “: Fundamental frequency.
  6. “#“: The radiated frequency is out the restricted band.



A D T

EUT TEST CONDITION		MEASUREMENT DETAIL	
CHANNEL	Channel 120	FREQUENCY RANGE	1 ~ 40GHz
INPUT POWER	120Vac, 60Hz	DETECTOR FUNCTION	Peak (PK) Average (AV)
ENVIRONMENTAL CONDITIONS	28deg. C, 75%R H 1009hPa	TESTED BY	Chad Lee
TEST MODE	A		

ANTENNA POLARITY & TEST DISTANCE: HORIZONTAL AT 3 M								
NO.	FREQ. (MHz)	EMISSION LEVEL (dBuV/m)	LIMIT (dBuV/m)	MARGIN (dB)	ANTENNA HEIGHT (m)	TABLE ANGLE (Degree)	RAW VALUE (dBuV)	CORRECTION FACTOR (dB/m)
1	*5600.00	116.8 PK			1.00 H	359	77.70	39.13
2	*5600.00	105.8 AV			1.00 H	359	66.70	39.13
3	11200.00	64.6 PK	74.0	-9.4	1.00 H	181	14.40	50.17
4	11200.00	49.3 AV	54.0	-4.7	1.00 H	181	-0.83	50.17
ANTENNA POLARITY & TEST DISTANCE: VERTICAL AT 3 M								
NO.	FREQ. (MHz)	EMISSION LEVEL (dBuV/m)	LIMIT (dBuV/m)	MARGIN (dB)	ANTENNA HEIGHT (m)	TABLE ANGLE (Degree)	RAW VALUE (dBuV)	CORRECTION FACTOR (dB/m)
1	*5600.00	117.2 PK			1.02 V	0	78.10	39.13
2	*5600.00	106.0 AV			1.02 V	0	66.87	39.13
3	11200.00	61.6 PK	74.0	-12.4	1.00 V	296	11.40	50.17
4	11200.00	48.5 AV	54.0	-5.5	1.00 V	296	-1.66	50.17

- REMARKS:**
1. Emission level (dBuV/m) = Raw Value (dBuV) + Correction Factor (dB/m).
  2. Correction Factor (dB/m) = Antenna Factor (dB/m) + Cable Factor (dB).
  3. The other emission levels were very low against the limit.
  4. Margin value = Emission level – Limit value.
  5. “ \* ”: Fundamental frequency.



A D T

EUT TEST CONDITION		MEASUREMENT DETAIL	
CHANNEL	Channel 140	FREQUENCY RANGE	1 ~ 40GHz
INPUT POWER	120Vac, 60Hz	DETECTOR FUNCTION	Peak (PK) Average (AV)
ENVIRONMENTAL CONDITIONS	28deg. C, 75%R H 1009hPa	TESTED BY	Chad Lee
TEST MODE	A		

ANTENNA POLARITY & TEST DISTANCE: HORIZONTAL AT 3 M								
NO.	FREQ. (MHz)	EMISSION LEVEL (dBuV/m)	LIMIT (dBuV/m)	MARGIN (dB)	ANTENNA HEIGHT (m)	TABLE ANGLE (Degree)	RAW VALUE (dBuV)	CORRECTION FACTOR (dB/m)
1	*5700.00	115.1 PK			1.00 H	1	75.67	39.39
2	*5700.00	103.5 AV			1.00 H	1	64.14	39.39
3	#5725.00	68.6 PK	88.3	-19.7	1.00 H	1	29.15	39.45
4	#5725.00	48.6 AV	68.3	-19.7	1.00 H	1	9.18	39.45
5	11400.00	66.0 PK	74.0	-8.0	1.13 H	102	15.98	50.04
6	11400.00	51.0 AV	54.0	-3.0	1.13 H	102	0.96	50.04
ANTENNA POLARITY & TEST DISTANCE: VERTICAL AT 3 M								
NO.	FREQ. (MHz)	EMISSION LEVEL (dBuV/m)	LIMIT (dBuV/m)	MARGIN (dB)	ANTENNA HEIGHT (m)	TABLE ANGLE (Degree)	RAW VALUE (dBuV)	CORRECTION FACTOR (dB/m)
1	*5700.00	116.1 PK			1.00 V	358	76.66	39.39
2	*5700.00	104.0 AV			1.00 V	358	64.63	39.39
3	#5725.00	72.3 PK	88.3	-16.0	1.00 V	358	32.88	39.45
4	#5725.00	51.8 AV	68.3	-16.5	1.00 V	358	12.33	39.45
5	11400.00	62.3 PK	74.0	-11.7	1.00 V	321	12.23	50.04
6	11400.00	49.2 AV	54.0	-4.8	1.00 V	321	-0.87	50.04

- REMARKS:**
1. Emission level (dBuV/m) = Raw Value (dBuV) + Correction Factor (dB/m).
  2. Correction Factor (dB/m) = Antenna Factor (dB/m) + Cable Factor (dB).
  3. The other emission levels were very low against the limit.
  4. Margin value = Emission level – Limit value.
  5. “ \* “: Fundamental frequency.
  6. “#”:The radiated frequency is out the restricted band.



A D T

EUT TEST CONDITION		MEASUREMENT DETAIL	
CHANNEL	Channel 52	FREQUENCY RANGE	1 ~ 40GHz
INPUT POWER	120Vac, 60Hz	DETECTOR FUNCTION	Peak (PK) Average (AV)
ENVIRONMENTAL CONDITIONS	28deg. C, 75%R H 1009hPa	TESTED BY	Chad Lee
TEST MODE	C		

**ANTENNA POLARITY & TEST DISTANCE: HORIZONTAL AT 3 M**

NO.	FREQ. (MHz)	EMISSION LEVEL (dBuV/m)	LIMIT (dBuV/m)	MARGIN (dB)	ANTENNA HEIGHT (m)	TABLE ANGLE (Degree)	RAW VALUE (dBuV)	CORRECTION FACTOR (dB/m)
1	5150.00	58.5 PK	74.0	-15.5	1.00 H	356	20.15	38.35
2	5150.00	47.8 AV	54.0	-6.2	1.00 H	356	9.41	38.35
3	*5260.00	121.7 PK			1.00 H	356	83.35	38.52
4	*5260.00	108.8 AV			1.00 H	356	70.23	38.52
5	#10520.00	59.7 PK	88.3	-28.6	1.00 H	10	10.36	49.33

**ANTENNA POLARITY & TEST DISTANCE: VERTICAL AT 3 M**

NO.	FREQ. (MHz)	EMISSION LEVEL (dBuV/m)	LIMIT (dBuV/m)	MARGIN (dB)	ANTENNA HEIGHT (m)	TABLE ANGLE (Degree)	RAW VALUE (dBuV)	CORRECTION FACTOR (dB/m)
1	5150.00	58.8 PK	74.0	-15.2	1.00 V	356	20.44	38.35
2	5150.00	47.8 AV	54.0	-6.2	1.00 V	356	9.40	38.35
3	*5260.00	121.3 PK			1.00 V	356	82.80	38.52
4	*5260.00	108.7 AV			1.00 V	356	70.13	38.52
5	#10520.00	64.3 PK	88.3	-24.0	1.00 V	203	14.99	49.33

- REMARKS:**
1. Emission level (dBuV/m) = Raw Value (dBuV) + Correction Factor (dB/m).
  2. Correction Factor (dB/m) = Antenna Factor (dB/m) + Cable Factor (dB).
  3. The other emission levels were very low against the limit.
  4. Margin value = Emission level – Limit value.
  5. “ \* “: Fundamental frequency.
  6. "#":The radiated frequency is out the restricted band.



A D T

EUT TEST CONDITION		MEASUREMENT DETAIL	
CHANNEL	Channel 60	FREQUENCY RANGE	1 ~ 40GHz
INPUT POWER	120Vac, 60Hz	DETECTOR FUNCTION	Peak (PK) Average (AV)
ENVIRONMENTAL CONDITIONS	28deg. C, 75%R H 1009hPa	TESTED BY	Chad Lee
TEST MODE	C		

ANTENNA POLARITY & TEST DISTANCE: HORIZONTAL AT 3 M								
NO.	FREQ. (MHz)	EMISSION LEVEL (dBuV/m)	LIMIT (dBuV/m)	MARGIN (dB)	ANTENNA HEIGHT (m)	TABLE ANGLE (Degree)	RAW VALUE (dBuV)	CORRECTION FACTOR (dB/m)
1	*5300.00	123.1 PK			1.00 H	355	84.59	38.55
2	*5300.00	110.6 AV			1.00 H	355	72.02	38.55
3	10600.00	64.0 PK	74.0	-10.0	1.00 H	159	14.54	49.49
4	10600.00	50.7 AV	54.0	-3.3	1.00 H	159	1.16	49.49
ANTENNA POLARITY & TEST DISTANCE: VERTICAL AT 3 M								
NO.	FREQ. (MHz)	EMISSION LEVEL (dBuV/m)	LIMIT (dBuV/m)	MARGIN (dB)	ANTENNA HEIGHT (m)	TABLE ANGLE (Degree)	RAW VALUE (dBuV)	CORRECTION FACTOR (dB/m)
1	*5300.00	122.4 PK			1.00 V	358	83.85	38.55
2	*5300.00	110.1 AV			1.00 V	358	71.58	38.55
3	10600.00	67.0 PK	74.0	-7.0	1.00 V	95	17.49	49.49
4	10600.00	52.5 AV	54.0	-1.5	1.00 V	95	3.02	49.49

- REMARKS:**
1. Emission level (dBuV/m) = Raw Value (dBuV) + Correction Factor (dB/m).
  2. Correction Factor (dB/m) = Antenna Factor (dB/m) + Cable Factor (dB).
  3. The other emission levels were very low against the limit.
  4. Margin value = Emission level – Limit value.
  5. “ \* “: Fundamental frequency.



A D T

EUT TEST CONDITION		MEASUREMENT DETAIL	
CHANNEL	Channel 64	FREQUENCY RANGE	1 ~ 40GHz
INPUT POWER	120Vac, 60Hz	DETECTOR FUNCTION	Peak (PK) Average (AV)
ENVIRONMENTAL CONDITIONS	28deg. C, 75%R H 1009hPa	TESTED BY	Chad Lee
TEST MODE	C		

ANTENNA POLARITY & TEST DISTANCE: HORIZONTAL AT 3 M								
NO.	FREQ. (MHz)	EMISSION LEVEL (dBuV/m)	LIMIT (dBuV/m)	MARGIN (dB)	ANTENNA HEIGHT (m)	TABLE ANGLE (Degree)	RAW VALUE (dBuV)	CORRECTION FACTOR (dB/m)
1	*5320.00	118.8 PK			1.00 H	356	80.18	38.58
2	*5320.00	106.1 AV			1.00 H	356	67.48	38.58
3	5350.00	66.0 PK	74.0	-8.0	1.00 H	356	27.40	38.63
4	5350.00	52.1 AV	54.0	-1.9	1.00 H	356	13.50	38.63
5	10640.00	60.3 PK	74.0	-13.7	1.00 H	135	10.74	49.56
6	10640.00	48.2 AV	54.0	-5.8	1.00 H	135	-1.33	49.56
ANTENNA POLARITY & TEST DISTANCE: VERTICAL AT 3 M								
NO.	FREQ. (MHz)	EMISSION LEVEL (dBuV/m)	LIMIT (dBuV/m)	MARGIN (dB)	ANTENNA HEIGHT (m)	TABLE ANGLE (Degree)	RAW VALUE (dBuV)	CORRECTION FACTOR (dB/m)
1	*5320.00	117.7 PK			1.00 V	359	79.13	38.58
2	*5320.00	106.0 AV			1.00 V	359	67.44	38.58
3	5350.00	66.0 PK	74.0	-8.0	1.00 V	359	27.38	38.63
4	5350.00	52.1 AV	54.0	-1.9	1.00 V	359	13.44	38.63
5	10640.00	62.4 PK	74.0	-11.6	1.00 V	95	12.88	49.56
6	10640.00	51.0 AV	54.0	-3.0	1.00 V	95	1.41	49.56

- REMARKS:**
1. Emission level (dBuV/m) = Raw Value (dBuV) + Correction Factor (dB/m).
  2. Correction Factor (dB/m) = Antenna Factor (dB/m) + Cable Factor (dB).
  3. The other emission levels were very low against the limit.
  4. Margin value = Emission level – Limit value.
  5. “ \* “: Fundamental frequency.



A D T

EUT TEST CONDITION		MEASUREMENT DETAIL	
CHANNEL	Channel 100	FREQUENCY RANGE	1 ~ 40GHz
INPUT POWER	120Vac, 60Hz	DETECTOR FUNCTION	Peak (PK) Average (AV)
ENVIRONMENTAL CONDITIONS	28deg. C, 75%R H 1009hPa	TESTED BY	Chad Lee
TEST MODE	C		

ANTENNA POLARITY & TEST DISTANCE: HORIZONTAL AT 3 M								
NO.	FREQ. (MHz)	EMISSION LEVEL (dBuV/m)	LIMIT (dBuV/m)	MARGIN (dB)	ANTENNA HEIGHT (m)	TABLE ANGLE (Degree)	RAW VALUE (dBuV)	CORRECTION FACTOR (dB/m)
1	5460.00	65.0 PK	74.0	-9.0	1.00 H	359	26.18	38.84
2	5460.00	52.2 AV	54.0	-1.8	1.00 H	359	13.37	38.84
3	#5470.00	65.8 PK	88.3	-22.5	1.00 H	359	26.90	38.86
4	#5470.00	52.2 AV	68.3	-16.1	1.00 H	359	13.31	38.86
5	*5500.00	119.9 PK			1.00 H	359	80.96	38.92
6	*5500.00	106.4 AV			1.00 H	359	67.44	38.92
7	11000.00	63.5 PK	74.0	-10.5	1.00 H	130	13.16	50.29
8	11000.00	49.2 AV	54.0	-4.8	1.00 H	130	-1.08	50.29
ANTENNA POLARITY & TEST DISTANCE: VERTICAL AT 3 M								
NO.	FREQ. (MHz)	EMISSION LEVEL (dBuV/m)	LIMIT (dBuV/m)	MARGIN (dB)	ANTENNA HEIGHT (m)	TABLE ANGLE (Degree)	RAW VALUE (dBuV)	CORRECTION FACTOR (dB/m)
1	5460.00	65.0 PK	74.0	-9.0	1.00 V	357	26.17	38.84
2	5460.00	52.1 AV	54.0	-1.9	1.00 V	357	13.22	38.84
3	#5470.00	65.6 PK	88.3	-22.7	1.00 V	357	26.78	38.86
4	#5470.00	52.1 AV	68.3	-16.2	1.00 V	357	13.19	38.86
5	*5500.00	119.7 PK			1.00 V	357	80.81	38.92
6	*5500.00	106.1 AV			1.00 V	357	67.19	38.92
7	11000.00	67.9 PK	74.0	-6.1	1.00 V	79	17.61	50.29
8	11000.00	53.1 AV	54.0	-0.9	1.00 V	79	2.69	50.29

- REMARKS:**
1. Emission level (dBuV/m) = Raw Value (dBuV) + Correction Factor (dB/m).
  2. Correction Factor (dB/m) = Antenna Factor (dB/m) + Cable Factor (dB).
  3. The other emission levels were very low against the limit.
  4. Margin value = Emission level – Limit value.
  5. “ \* “: Fundamental frequency.
  6. “#”:The radiated frequency is out the restricted band.





A D T

EUT TEST CONDITION		MEASUREMENT DETAIL	
CHANNEL	Channel 120	FREQUENCY RANGE	1 ~ 40GHz
INPUT POWER	120Vac, 60Hz	DETECTOR FUNCTION	Peak (PK) Average (AV)
ENVIRONMENTAL CONDITIONS	28deg. C, 75%R H 1009hPa	TESTED BY	Chad Lee
TEST MODE	C		

ANTENNA POLARITY & TEST DISTANCE: HORIZONTAL AT 3 M								
NO.	FREQ. (MHz)	EMISSION LEVEL (dBuV/m)	LIMIT (dBuV/m)	MARGIN (dB)	ANTENNA HEIGHT (m)	TABLE ANGLE (Degree)	RAW VALUE (dBuV)	CORRECTION FACTOR (dB/m)
1	*5600.00	119.4 PK			1.00 H	358	80.28	39.13
2	*5600.00	109.8 AV			1.00 H	358	70.62	39.13
3	11200.00	59.8 PK	74.0	-14.2	1.00 H	15	9.66	50.17
4	11200.00	47.0 AV	54.0	-7.0	1.00 H	15	-3.16	50.17
ANTENNA POLARITY & TEST DISTANCE: VERTICAL AT 3 M								
NO.	FREQ. (MHz)	EMISSION LEVEL (dBuV/m)	LIMIT (dBuV/m)	MARGIN (dB)	ANTENNA HEIGHT (m)	TABLE ANGLE (Degree)	RAW VALUE (dBuV)	CORRECTION FACTOR (dB/m)
1	*5600.00	118.5 PK			1.00 V	357	79.38	39.13
2	*5600.00	108.4 AV			1.00 V	357	69.31	39.13
3	11200.00	63.6 PK	74.0	-10.4	1.00 V	97	13.43	50.17
4	11200.00	50.9 AV	54.0	-3.1	1.00 V	97	0.72	50.17

- REMARKS:**
1. Emission level (dBuV/m) = Raw Value (dBuV) + Correction Factor (dB/m).
  2. Correction Factor (dB/m) = Antenna Factor (dB/m) + Cable Factor (dB).
  3. The other emission levels were very low against the limit.
  4. Margin value = Emission level – Limit value.
  5. “ \* “: Fundamental frequency.



A D T

EUT TEST CONDITION		MEASUREMENT DETAIL	
CHANNEL	Channel 140	FREQUENCY RANGE	1 ~ 40GHz
INPUT POWER	120Vac, 60Hz	DETECTOR FUNCTION	Peak (PK) Average (AV)
ENVIRONMENTAL CONDITIONS	28deg. C, 75%R H 1009hPa	TESTED BY	Chad Lee
TEST MODE	C		

ANTENNA POLARITY & TEST DISTANCE: HORIZONTAL AT 3 M								
NO.	FREQ. (MHz)	EMISSION LEVEL (dBuV/m)	LIMIT (dBuV/m)	MARGIN (dB)	ANTENNA HEIGHT (m)	TABLE ANGLE (Degree)	RAW VALUE (dBuV)	CORRECTION FACTOR (dB/m)
1	*5700.00	119.7 PK			1.00 H	358	80.30	39.39
2	*5700.00	106.5 AV			1.00 H	358	67.07	39.39
3	#5725.00	63.4 PK	88.3	-24.9	1.00 H	358	23.98	39.45
4	#5725.00	46.8 AV	68.3	-21.5	1.00 H	358	7.35	39.45
5	11400.00	60.1 PK	74.0	-13.9	1.00 H	106	10.05	50.04
6	11400.00	48.2 AV	54.0	-5.8	1.00 H	106	-1.79	50.04
ANTENNA POLARITY & TEST DISTANCE: VERTICAL AT 3 M								
NO.	FREQ. (MHz)	EMISSION LEVEL (dBuV/m)	LIMIT (dBuV/m)	MARGIN (dB)	ANTENNA HEIGHT (m)	TABLE ANGLE (Degree)	RAW VALUE (dBuV)	CORRECTION FACTOR (dB/m)
1	*5700.00	119.1 PK			1.00 V	358	79.67	39.39
2	*5700.00	105.8 AV			1.00 V	358	66.39	39.39
3	#5725.00	62.4 PK	88.3	25.9	1.00 V	358	22.90	39.45
4	#5725.00	46.1 AV	68.3	-22.2	1.00 V	358	6.61	39.45
5	11400.00	64.4 PK	74.0	-9.6	1.00 V	91	14.35	50.04
6	11400.00	50.3 AV	54.0	-3.7	1.00 V	91	0.30	50.04

- REMARKS:**
1. Emission level (dBuV/m) = Raw Value (dBuV) + Correction Factor (dB/m).
  2. Correction Factor (dB/m) = Antenna Factor (dB/m) + Cable Factor (dB).
  3. The other emission levels were very low against the limit.
  4. Margin value = Emission level – Limit value.
  5. “ \* “: Fundamental frequency.
  6. “#”:The radiated frequency is out the restricted band.



A D T

802.11n (20MHz)

EUT TEST CONDITION		MEASUREMENT DETAIL	
CHANNEL	Channel 52	FREQUENCY RANGE	1 ~ 40GHz
INPUT POWER	120Vac, 60Hz	DETECTOR FUNCTION	Peak (PK) Average (AV)
ENVIRONMENTAL CONDITIONS	28deg. C, 75%R H 1009hPa	TESTED BY	Chad Lee
TEST MODE	A		

ANTENNA POLARITY & TEST DISTANCE: HORIZONTAL AT 3 M								
NO.	FREQ. (MHz)	EMISSION LEVEL (dBuV/m)	LIMIT (dBuV/m)	MARGIN (dB)	ANTENNA HEIGHT (m)	TABLE ANGLE (Degree)	RAW VALUE (dBuV)	CORRECTION FACTOR (dB/m)
1	5150.00	51.3 PK	74.0	-22.7	1.00 H	1	12.95	38.35
2	5150.00	39.1 AV	54.0	-14.9	1.00 H	1	0.76	38.35
3	*5260.00	121.5 PK			1.00 H	1	82.93	38.52
4	*5260.00	111.6 AV			1.00 H	1	73.06	38.52
5	#10520.00	62.4 PK	88.3	-25.9	1.00 H	353	13.04	49.33
ANTENNA POLARITY & TEST DISTANCE: VERTICAL AT 3 M								
NO.	FREQ. (MHz)	EMISSION LEVEL (dBuV/m)	LIMIT (dBuV/m)	MARGIN (dB)	ANTENNA HEIGHT (m)	TABLE ANGLE (Degree)	RAW VALUE (dBuV)	CORRECTION FACTOR (dB/m)
1	5150.00	51.4 PK	74.0	-22.6	1.00 V	356	13.01	38.35
2	5150.00	39.1 AV	54.0	-14.9	1.00 V	356	0.79	38.35
3	*5260.00	122.7 PK			1.00 V	356	84.22	38.52
4	*5260.00	112.0 AV			1.00 V	356	73.51	38.52
5	#10520.00	59.0 PK	88.3	-29.3	1.07 V	87	9.71	49.33

- REMARKS:**
1. Emission level (dBuV/m) = Raw Value (dBuV) + Correction Factor (dB/m).
  2. Correction Factor (dB/m) = Antenna Factor (dB/m) + Cable Factor (dB).
  3. The other emission levels were very low against the limit.
  4. Margin value = Emission level – Limit value.
  5. “ \* “: Fundamental frequency.
  6. “#”:The radiated frequency is out the restricted band.



A D T

EUT TEST CONDITION		MEASUREMENT DETAIL	
CHANNEL	Channel 60	FREQUENCY RANGE	1 ~ 40GHz
INPUT POWER	120Vac, 60Hz	DETECTOR FUNCTION	Peak (PK) Average (AV)
ENVIRONMENTAL CONDITIONS	28deg. C, 75%R H 1009hPa	TESTED BY	Chad Lee
TEST MODE	A		

ANTENNA POLARITY & TEST DISTANCE: HORIZONTAL AT 3 M								
NO.	FREQ. (MHz)	EMISSION LEVEL (dBuV/m)	LIMIT (dBuV/m)	MARGIN (dB)	ANTENNA HEIGHT (m)	TABLE ANGLE (Degree)	RAW VALUE (dBuV)	CORRECTION FACTOR (dB/m)
1	*5300.00	121.5 PK			1.00 H	349	82.93	38.55
2	*5300.00	111.7 AV			1.00 H	349	73.15	38.55
3	10600.00	60.8 PK	74.0	-13.2	1.00 H	17	11.34	49.49
4	10600.00	49.2 AV	54.0	-4.8	1.00 H	17	-0.33	49.49
ANTENNA POLARITY & TEST DISTANCE: VERTICAL AT 3 M								
NO.	FREQ. (MHz)	EMISSION LEVEL (dBuV/m)	LIMIT (dBuV/m)	MARGIN (dB)	ANTENNA HEIGHT (m)	TABLE ANGLE (Degree)	RAW VALUE (dBuV)	CORRECTION FACTOR (dB/m)
1	*5300.00	122.9 PK			1.00 V	0	84.39	38.55
2	*5300.00	112.3 AV			1.00 V	0	73.71	38.55
3	10600.00	61.6 PK	74.0	-12.4	1.00 V	19	12.14	49.49
4	10600.00	48.2 AV	54.0	-5.8	1.00 V	19	-1.27	49.49

- REMARKS:**
1. Emission level (dBuV/m) = Raw Value (dBuV) + Correction Factor (dB/m).
  2. Correction Factor (dB/m) = Antenna Factor (dB/m) + Cable Factor (dB).
  3. The other emission levels were very low against the limit.
  4. Margin value = Emission level – Limit value.
  5. “ \* “: Fundamental frequency.



A D T

EUT TEST CONDITION		MEASUREMENT DETAIL	
CHANNEL	Channel 64	FREQUENCY RANGE	1 ~ 40GHz
INPUT POWER	120Vac, 60Hz	DETECTOR FUNCTION	Peak (PK) Average (AV)
ENVIRONMENTAL CONDITIONS	28deg. C, 75%R H 1009hPa	TESTED BY	Chad Lee
TEST MODE	A		

**ANTENNA POLARITY & TEST DISTANCE: HORIZONTAL AT 3 M**

NO.	FREQ. (MHz)	EMISSION LEVEL (dBuV/m)	LIMIT (dBuV/m)	MARGIN (dB)	ANTENNA HEIGHT (m)	TABLE ANGLE (Degree)	RAW VALUE (dBuV)	CORRECTION FACTOR (dB/m)
1	*5320.00	116.8 PK			1.00 H	0	78.24	38.58
2	*5320.00	106.5 AV			1.00 H	0	67.91	38.58
3	5350.00	67.5 PK	74.0	-6.5	1.00 H	0	28.91	38.63
4	5350.00	49.0 AV	54.0	-5.0	1.00 H	0	10.40	38.63
5	10640.00	60.1 PK	74.0	-13.9	1.00 H	337	10.53	49.56
6	10640.00	47.2 AV	54.0	-6.8	1.00 H	337	-2.37	49.56

**ANTENNA POLARITY & TEST DISTANCE: VERTICAL AT 3 M**

NO.	FREQ. (MHz)	EMISSION LEVEL (dBuV/m)	LIMIT (dBuV/m)	MARGIN (dB)	ANTENNA HEIGHT (m)	TABLE ANGLE (Degree)	RAW VALUE (dBuV)	CORRECTION FACTOR (dB/m)
1	*5320.00	117.6 PK			1.00 V	0	79.00	38.58
2	*5320.00	107.7 AV			1.00 V	0	69.10	38.58
3	5350.00	68.0 PK	74.0	-6.0	1.00 V	0	29.36	38.63
4	5350.00	49.2 AV	54.0	-4.8	1.00 V	0	10.56	38.63
5	10640.00	59.8 PK	74.0	-14.2	1.11 V	9	10.25	49.56
6	10640.00	47.6 AV	54.0	-6.4	1.11 V	9	-1.95	49.56

- REMARKS:**
1. Emission level (dBuV/m) = Raw Value (dBuV) + Correction Factor (dB/m).
  2. Correction Factor (dB/m) = Antenna Factor (dB/m) + Cable Factor (dB).
  3. The other emission levels were very low against the limit.
  4. Margin value = Emission level – Limit value.
  5. “ \* “: Fundamental frequency.



A D T

EUT TEST CONDITION		MEASUREMENT DETAIL	
CHANNEL	Channel 100	FREQUENCY RANGE	1 ~ 40GHz
INPUT POWER	120Vac, 60Hz	DETECTOR FUNCTION	Peak (PK) Average (AV)
ENVIRONMENTAL CONDITIONS	28deg. C, 75%R H 1009hPa	TESTED BY	Chad Lee
TEST MODE	A		

ANTENNA POLARITY & TEST DISTANCE: HORIZONTAL AT 3 M								
NO.	FREQ. (MHz)	EMISSION LEVEL (dBuV/m)	LIMIT (dBuV/m)	MARGIN (dB)	ANTENNA HEIGHT (m)	TABLE ANGLE (Degree)	RAW VALUE (dBuV)	CORRECTION FACTOR (dB/m)
1	5460.00	62.6 PK	74.0	-11.4	1.00 H	0	23.72	38.84
2	5460.00	47.0 AV	54.0	-7.0	1.00 H	0	8.11	38.84
3	#5470.00	69.4 PK	88.3	-18.9	1.00 H	0	30.50	38.86
4	#5470.00	49.7 AV	68.3	-18.6	1.00 H	0	10.80	38.86
5	*5500.00	117.2 PK			1.00 H	0	78.27	38.92
6	*5500.00	105.4 AV			1.00 H	0	66.46	38.92
7	11000.00	64.9 PK	74.0	-9.1	1.00 H	79	14.56	50.29
8	11000.00	51.6 AV	54.0	-2.4	1.00 H	79	1.34	50.29
ANTENNA POLARITY & TEST DISTANCE: VERTICAL AT 3 M								
NO.	FREQ. (MHz)	EMISSION LEVEL (dBuV/m)	LIMIT (dBuV/m)	MARGIN (dB)	ANTENNA HEIGHT (m)	TABLE ANGLE (Degree)	RAW VALUE (dBuV)	CORRECTION FACTOR (dB/m)
1	5460.00	62.5 PK	74.0	-11.5	1.00 V	358	23.66	38.84
2	5460.00	47.0 AV	54.0	-7.0	1.00 V	358	8.15	38.84
3	#5470.00	69.8 PK	88.3	-18.5	1.00 V	358	30.93	38.86
4	#5470.00	49.7 AV	68.3	-18.6	1.00 V	358	10.82	38.86
5	*5500.00	118.0 PK			1.00 V	358	79.09	38.92
6	*5500.00	106.0 AV			1.00 V	358	67.08	38.92
7	11000.00	63.1 PK	74.0	-10.9	1.00 V	67	12.68	50.29
8	11000.00	49.5 AV	54.0	-4.5	1.00 V	67	-0.75	50.29

- REMARKS:**
1. Emission level (dBuV/m) = Raw Value (dBuV) + Correction Factor (dB/m).
  2. Correction Factor (dB/m) = Antenna Factor (dB/m) + Cable Factor (dB).
  3. The other emission levels were very low against the limit.
  4. Margin value = Emission level – Limit value.
  5. “ \* “: Fundamental frequency.
  6. “#”:The radiated frequency is out the restricted band.



A D T

EUT TEST CONDITION		MEASUREMENT DETAIL	
CHANNEL	Channel 120	FREQUENCY RANGE	1 ~ 40GHz
INPUT POWER	120Vac, 60Hz	DETECTOR FUNCTION	Peak (PK) Average (AV)
ENVIRONMENTAL CONDITIONS	28deg. C, 75%R H 1009hPa	TESTED BY	Chad Lee
TEST MODE	A		

ANTENNA POLARITY & TEST DISTANCE: HORIZONTAL AT 3 M								
NO.	FREQ. (MHz)	EMISSION LEVEL (dBuV/m)	LIMIT (dBuV/m)	MARGIN (dB)	ANTENNA HEIGHT (m)	TABLE ANGLE (Degree)	RAW VALUE (dBuV)	CORRECTION FACTOR (dB/m)
1	*5600.00	117.9 PK			1.00 H	359	78.81	39.13
2	*5600.00	106.9 AV			1.00 H	359	67.80	39.13
3	11200.00	64.8 PK	74.0	-9.2	1.00 H	172	14.61	50.17
4	11200.00	50.6 AV	54.0	-3.4	1.00 H	172	0.38	50.17
ANTENNA POLARITY & TEST DISTANCE: VERTICAL AT 3 M								
NO.	FREQ. (MHz)	EMISSION LEVEL (dBuV/m)	LIMIT (dBuV/m)	MARGIN (dB)	ANTENNA HEIGHT (m)	TABLE ANGLE (Degree)	RAW VALUE (dBuV)	CORRECTION FACTOR (dB/m)
1	*5600.00	118.3 PK			1.04 V	0	79.21	39.13
2	*5600.00	107.1 AV			1.04 V	0	67.98	39.13
3	11200.00	62.8 PK	74.0	-11.2	1.00 V	300	12.62	50.17
4	11200.00	49.6 AV	54.0	-4.4	1.00 V	300	-0.55	50.17

- REMARKS:**
1. Emission level (dBuV/m) = Raw Value (dBuV) + Correction Factor (dB/m).
  2. Correction Factor (dB/m) = Antenna Factor (dB/m) + Cable Factor (dB).
  3. The other emission levels were very low against the limit.
  4. Margin value = Emission level – Limit value.
  5. “ \* ”: Fundamental frequency.



A D T

EUT TEST CONDITION		MEASUREMENT DETAIL	
CHANNEL	Channel 140	FREQUENCY RANGE	1 ~ 40GHz
INPUT POWER	120Vac, 60Hz	DETECTOR FUNCTION	Peak (PK) Average (AV)
ENVIRONMENTAL CONDITIONS	28deg. C, 75%R H 1009hPa	TESTED BY	Chad Lee
TEST MODE	A		

ANTENNA POLARITY & TEST DISTANCE: HORIZONTAL AT 3 M								
NO.	FREQ. (MHz)	EMISSION LEVEL (dBuV/m)	LIMIT (dBuV/m)	MARGIN (dB)	ANTENNA HEIGHT (m)	TABLE ANGLE (Degree)	RAW VALUE (dBuV)	CORRECTION FACTOR (dB/m)
1	*5700.00	116.06 PK			1.00 H	2	76.67	39.39
2	*5700.00	104.54 AV			1.00 H	2	65.15	39.39
3	#5725.00	69.71 PK	88.3	-18.59	1.00 H	2	30.26	39.45
4	#5725.00	49.63 AV	68.3	-18.67	1.00 H	2	10.18	39.45
5	11400.00	66.22 PK	74.0	-7.78	1.13 H	92	16.18	50.04
6	11400.00	51.11 AV	54.0	-2.89	1.13 H	92	1.07	50.04
ANTENNA POLARITY & TEST DISTANCE: VERTICAL AT 3 M								
NO.	FREQ. (MHz)	EMISSION LEVEL (dBuV/m)	LIMIT (dBuV/m)	MARGIN (dB)	ANTENNA HEIGHT (m)	TABLE ANGLE (Degree)	RAW VALUE (dBuV)	CORRECTION FACTOR (dB/m)
1	*5700.00	117.1 PK			1.00 V	356	77.66	39.39
2	*5700.00	105.0 AV			1.00 V	356	65.63	39.39
3	#5725.00	73.4 PK	88.3	-14.9	1.00 V	356	33.99	39.45
4	#5725.00	52.8 AV	68.3	-15.5	1.00 V	356	13.37	39.45
5	11400.00	62.5 PK	74.0	-11.5	1.00 V	320	12.44	50.04
6	11400.00	49.4 AV	54.0	-4.6	1.00 V	320	-0.67	50.04

- REMARKS:**
1. Emission level (dBuV/m) = Raw Value (dBuV) + Correction Factor (dB/m).
  2. Correction Factor (dB/m) = Antenna Factor (dB/m) + Cable Factor (dB).
  3. The other emission levels were very low against the limit.
  4. Margin value = Emission level – Limit value.
  5. “ \* “: Fundamental frequency.
  6. “#”:The radiated frequency is out the restricted band.





A D T

EUT TEST CONDITION		MEASUREMENT DETAIL	
CHANNEL	Channel 52	FREQUENCY RANGE	1 ~ 40GHz
INPUT POWER	120Vac, 60Hz	DETECTOR FUNCTION	Peak (PK) Average (AV)
ENVIRONMENTAL CONDITIONS	28deg. C, 75%R H 1009hPa	TESTED BY	Chad Lee
TEST MODE	C		

**ANTENNA POLARITY & TEST DISTANCE: HORIZONTAL AT 3 M**

NO.	FREQ. (MHz)	EMISSION LEVEL (dBuV/m)	LIMIT (dBuV/m)	MARGIN (dB)	ANTENNA HEIGHT (m)	TABLE ANGLE (Degree)	RAW VALUE (dBuV)	CORRECTION FACTOR (dB/m)
1	5150.00	59.6 PK	74.0	-14.4	1.00 H	356	21.25	38.35
2	5150.00	48.9 AV	54.0	-5.1	1.00 H	356	10.52	38.35
3	*5260.00	123.0 PK			1.00 H	356	84.45	38.52
4	*5260.00	109.9 AV			1.00 H	356	71.34	38.52
5	#10520.00	59.8 PK	88.3	-28.5	1.00 H	14	10.47	49.33

**ANTENNA POLARITY & TEST DISTANCE: VERTICAL AT 3 M**

NO.	FREQ. (MHz)	EMISSION LEVEL (dBuV/m)	LIMIT (dBuV/m)	MARGIN (dB)	ANTENNA HEIGHT (m)	TABLE ANGLE (Degree)	RAW VALUE (dBuV)	CORRECTION FACTOR (dB/m)
1	5150.00	59.8 PK	74.0	-14.2	1.00 V	356	21.48	38.35
2	5150.00	48.4 AV	54.0	-5.6	1.00 V	356	10.00	38.35
3	*5260.00	122.4 PK			1.00 V	356	83.92	38.52
4	*5260.00	109.8 AV			1.00 V	356	71.23	38.52
5	#10520.00	64.6 PK	88.3	-23.7	1.00 V	93	15.22	49.33

- REMARKS:**
1. Emission level (dBuV/m) = Raw Value (dBuV) + Correction Factor (dB/m).
  2. Correction Factor (dB/m) = Antenna Factor (dB/m) + Cable Factor (dB).
  3. The other emission levels were very low against the limit.
  4. Margin value = Emission level – Limit value.
  5. “ \* “: Fundamental frequency.
  6. “#“:The radiated frequency is out the restricted band.



A D T

EUT TEST CONDITION		MEASUREMENT DETAIL	
CHANNEL	Channel 60	FREQUENCY RANGE	1 ~ 40GHz
INPUT POWER	120Vac, 60Hz	DETECTOR FUNCTION	Peak (PK) Average (AV)
ENVIRONMENTAL CONDITIONS	28deg. C, 75%R H 1009hPa	TESTED BY	Chad Lee
TEST MODE	C		

ANTENNA POLARITY & TEST DISTANCE: HORIZONTAL AT 3 M								
NO.	FREQ. (MHz)	EMISSION LEVEL (dBuV/m)	LIMIT (dBuV/m)	MARGIN (dB)	ANTENNA HEIGHT (m)	TABLE ANGLE (Degree)	RAW VALUE (dBuV)	CORRECTION FACTOR (dB/m)
1	*5300.00	124.3 PK			1.00 H	355	85.70	38.55
2	*5300.00	111.7 AV			1.00 H	355	73.14	38.55
3	10600.00	65.1 PK	74.0	-8.9	1.00 H	159	15.59	49.49
4	10600.00	51.8 AV	54.0	-2.2	1.00 H	159	2.27	49.49
ANTENNA POLARITY & TEST DISTANCE: VERTICAL AT 3 M								
NO.	FREQ. (MHz)	EMISSION LEVEL (dBuV/m)	LIMIT (dBuV/m)	MARGIN (dB)	ANTENNA HEIGHT (m)	TABLE ANGLE (Degree)	RAW VALUE (dBuV)	CORRECTION FACTOR (dB/m)
1	*5300.00	123.5 PK			1.00 V	358	84.98	38.55
2	*5300.00	111.3 AV			1.00 V	358	72.77	38.55
3	10600.00	68.0 PK	74.0	-6.0	1.00 V	95	18.52	49.49
4	10600.00	53.6 AV	54.0	-0.4	1.00 V	95	4.13	49.49

- REMARKS:**
1. Emission level (dBuV/m) = Raw Value (dBuV) + Correction Factor (dB/m).
  2. Correction Factor (dB/m) = Antenna Factor (dB/m) + Cable Factor (dB).
  3. The other emission levels were very low against the limit.
  4. Margin value = Emission level – Limit value.
  5. “ \* “: Fundamental frequency.



A D T

EUT TEST CONDITION		MEASUREMENT DETAIL	
CHANNEL	Channel 64	FREQUENCY RANGE	1 ~ 40GHz
INPUT POWER	120Vac, 60Hz	DETECTOR FUNCTION	Peak (PK) Average (AV)
ENVIRONMENTAL CONDITIONS	28deg. C, 75%R H 1009hPa	TESTED BY	Chad Lee
TEST MODE	C		

ANTENNA POLARITY & TEST DISTANCE: HORIZONTAL AT 3 M								
NO.	FREQ. (MHz)	EMISSION LEVEL (dBuV/m)	LIMIT (dBuV/m)	MARGIN (dB)	ANTENNA HEIGHT (m)	TABLE ANGLE (Degree)	RAW VALUE (dBuV)	CORRECTION FACTOR (dB/m)
1	*5320.00	119.9 PK			1.00 H	355	81.30	38.58
2	*5320.00	108.1 AV			1.00 H	355	69.50	38.58
3	5350.00	67.1 PK	74.0	-6.9	1.00 H	355	28.50	38.63
4	5350.00	53.2 AV	54.0	-0.8	1.00 H	355	14.60	38.63
5	10640.00	61.3 PK	74.0	-12.7	1.00 H	132	11.74	49.56
6	10640.00	49.2 AV	54.0	-4.8	1.00 H	132	-0.33	49.56
ANTENNA POLARITY & TEST DISTANCE: VERTICAL AT 3 M								
NO.	FREQ. (MHz)	EMISSION LEVEL (dBuV/m)	LIMIT (dBuV/m)	MARGIN (dB)	ANTENNA HEIGHT (m)	TABLE ANGLE (Degree)	RAW VALUE (dBuV)	CORRECTION FACTOR (dB/m)
1	*5320.00	118.4 PK			1.00 V	358	79.83	38.58
2	*5320.00	107.7 AV			1.00 V	358	69.14	38.58
3	5350.00	67.0 PK	74.0	-7.0	1.00 V	358	28.38	38.63
4	5350.00	53.1 AV	54.0	-0.9	1.00 V	358	14.45	38.63
5	10640.00	63.5 PK	74.0	-10.5	1.00 V	105	13.98	49.56
6	10640.00	51.9 AV	54.0	-2.1	1.00 V	105	2.32	49.56

- REMARKS:**
1. Emission level (dBuV/m) = Raw Value (dBuV) + Correction Factor (dB/m).
  2. Correction Factor (dB/m) = Antenna Factor (dB/m) + Cable Factor (dB).
  3. The other emission levels were very low against the limit.
  4. Margin value = Emission level – Limit value.
  5. “ \* “: Fundamental frequency.



A D T

EUT TEST CONDITION		MEASUREMENT DETAIL	
CHANNEL	Channel 100	FREQUENCY RANGE	1 ~ 40GHz
INPUT POWER	120Vac, 60Hz	DETECTOR FUNCTION	Peak (PK) Average (AV)
ENVIRONMENTAL CONDITIONS	28deg. C, 75%R H 1009hPa	TESTED BY	Chad Lee
TEST MODE	C		

ANTENNA POLARITY & TEST DISTANCE: HORIZONTAL AT 3 M								
NO.	FREQ. (MHz)	EMISSION LEVEL (dBuV/m)	LIMIT (dBuV/m)	MARGIN (dB)	ANTENNA HEIGHT (m)	TABLE ANGLE (Degree)	RAW VALUE (dBuV)	CORRECTION FACTOR (dB/m)
1	5460.00	66.0 PK	74.0	-8.0	1.00 H	357	27.19	38.84
2	5460.00	53.3 AV	54.0	-0.7	1.00 H	357	14.49	38.84
3	#5470.00	66.7 PK	88.3	-21.6	1.00 H	357	27.79	38.86
4	#5470.00	53.1 AV	68.3	-15.2	1.00 H	357	14.20	38.86
5	*5500.00	120.8 PK			1.00 H	357	81.87	38.92
6	*5500.00	107.2 AV			1.00 H	357	68.32	38.92
7	11000.00	64.6 PK	74.0	-9.4	1.00 H	134	14.27	50.29
8	11000.00	50.2 AV	54.0	-3.8	1.00 H	134	-0.08	50.29
ANTENNA POLARITY & TEST DISTANCE: VERTICAL AT 3 M								
NO.	FREQ. (MHz)	EMISSION LEVEL (dBuV/m)	LIMIT (dBuV/m)	MARGIN (dB)	ANTENNA HEIGHT (m)	TABLE ANGLE (Degree)	RAW VALUE (dBuV)	CORRECTION FACTOR (dB/m)
1	5460.00	66.0 PK	74.0	-8.0	1.00 V	356	27.14	38.84
2	5460.00	53.2 AV	54.0	-0.8	1.00 V	356	14.37	38.84
3	#5470.00	66.4 PK	88.3	-21.9	1.00 V	356	27.56	38.86
4	#5470.00	53.0 AV	68.3	-15.3	1.00 V	356	14.13	38.86
5	*5500.00	120.6 PK			1.00 V	356	81.70	38.92
6	*5500.00	107.1 AV			1.00 V	356	68.15	38.92
7	11000.00	68.4 PK	74.0	-5.6	1.00 V	81	18.11	50.29
8	11000.00	53.7 AV	54.0	-0.3	1.00 V	81	3.39	50.29

- REMARKS:**
1. Emission level (dBuV/m) = Raw Value (dBuV) + Correction Factor (dB/m).
  2. Correction Factor (dB/m) = Antenna Factor (dB/m) + Cable Factor (dB).
  3. The other emission levels were very low against the limit.
  4. Margin value = Emission level – Limit value.
  5. “ \* “: Fundamental frequency.
  6. “#”:The radiated frequency is out the restricted band.



A D T

EUT TEST CONDITION		MEASUREMENT DETAIL	
CHANNEL	Channel 120	FREQUENCY RANGE	1 ~ 40GHz
INPUT POWER	120Vac, 60Hz	DETECTOR FUNCTION	Peak (PK) Average (AV)
ENVIRONMENTAL CONDITIONS	28deg. C, 75%R H 1009hPa	TESTED BY	Chad Lee
TEST MODE	C		

ANTENNA POLARITY & TEST DISTANCE: HORIZONTAL AT 3 M								
NO.	FREQ. (MHz)	EMISSION LEVEL (dBuV/m)	LIMIT (dBuV/m)	MARGIN (dB)	ANTENNA HEIGHT (m)	TABLE ANGLE (Degree)	RAW VALUE (dBuV)	CORRECTION FACTOR (dB/m)
1	*5600.00	120.6 PK			1.00 H	356	81.41	39.13
2	*5600.00	111.0 AV			1.00 H	356	71.83	39.13
3	11200.00	60.9 PK	74.0	-13.1	1.00 H	13	10.77	50.17
4	11200.00	48.08 AV	54.0	-5.92	1.00 H	13	-2.19	50.17
ANTENNA POLARITY & TEST DISTANCE: VERTICAL AT 3 M								
NO.	FREQ. (MHz)	EMISSION LEVEL (dBuV/m)	LIMIT (dBuV/m)	MARGIN (dB)	ANTENNA HEIGHT (m)	TABLE ANGLE (Degree)	RAW VALUE (dBuV)	CORRECTION FACTOR (dB/m)
1	*5600.00	119.7 PK			1.00 V	355	80.58	39.13
2	*5600.00	109.7 AV			1.00 V	355	70.52	39.13
3	11200.00	64.7 PK	74.0	-9.3	1.00 V	97	14.55	50.17
4	11200.00	52.0 AV	54.0	-2.0	1.00 V	97	1.81	50.17

- REMARKS:**
1. Emission level (dBuV/m) = Raw Value (dBuV) + Correction Factor (dB/m).
  2. Correction Factor (dB/m) = Antenna Factor (dB/m) + Cable Factor (dB).
  3. The other emission levels were very low against the limit.
  4. Margin value = Emission level – Limit value.
  5. “ \* ”: Fundamental frequency.



A D T

EUT TEST CONDITION		MEASUREMENT DETAIL	
CHANNEL	Channel 140	FREQUENCY RANGE	1 ~ 40GHz
INPUT POWER	120Vac, 60Hz	DETECTOR FUNCTION	Peak (PK) Average (AV)
ENVIRONMENTAL CONDITIONS	28deg. C, 75%R H 1009hPa	TESTED BY	Chad Lee
TEST MODE	C		

ANTENNA POLARITY & TEST DISTANCE: HORIZONTAL AT 3 M								
NO.	FREQ. (MHz)	EMISSION LEVEL (dBuV/m)	LIMIT (dBuV/m)	MARGIN (dB)	ANTENNA HEIGHT (m)	TABLE ANGLE (Degree)	RAW VALUE (dBuV)	CORRECTION FACTOR (dB/m)
1	*5700.00	120.5 PK			1.00 H	356	81.10	39.39
2	*5700.00	107.2 AV			1.00 H	356	67.77	39.39
3	#5725.00	64.1 PK	88.3	-24.2	1.00 H	356	24.67	39.45
4	#5725.00	47.5 AV	68.3	-20.8	1.00 H	356	8.06	39.45
5	11400.00	61.1 PK	74.0	-12.9	1.00 H	205	11.06	50.04
6	11400.00	49.3 AV	54.0	-4.7	1.00 H	205	-0.77	50.04
ANTENNA POLARITY & TEST DISTANCE: VERTICAL AT 3 M								
NO.	FREQ. (MHz)	EMISSION LEVEL (dBuV/m)	LIMIT (dBuV/m)	MARGIN (dB)	ANTENNA HEIGHT (m)	TABLE ANGLE (Degree)	RAW VALUE (dBuV)	CORRECTION FACTOR (dB/m)
1	*5700.00	120.1 PK			1.00 V	358	80.68	39.39
2	*5700.00	106.8 AV			1.00 V	358	67.41	39.39
3	#5725.00	63.4 PK	88.3	-24.9	1.00 V	358	23.96	39.45
4	#5725.00	46.9 AV	68.3	-21.4	1.00 V	358	7.49	39.45
5	11400.00	65.4 PK	74.0	-8.6	1.00 V	89	15.32	50.04
6	11400.00	51.3 AV	54.0	-2.7	1.00 V	89	1.26	50.04

- REMARKS:**
1. Emission level (dBuV/m) = Raw Value (dBuV) + Correction Factor (dB/m).
  2. Correction Factor (dB/m) = Antenna Factor (dB/m) + Cable Factor (dB).
  3. The other emission levels were very low against the limit.
  4. Margin value = Emission level – Limit value.
  5. “ \* “: Fundamental frequency.
  6. “#”:The radiated frequency is out the restricted band.



A D T

802.11n (40MHz)

EUT TEST CONDITION		MEASUREMENT DETAIL	
CHANNEL	Channel 54	FREQUENCY RANGE	1 ~ 40GHz
INPUT POWER	120Vac, 60Hz	DETECTOR FUNCTION	Peak (PK) Average (AV)
ENVIRONMENTAL CONDITIONS	28deg. C, 75%R H 1009hPa	TESTED BY	Chad Lee
TEST MODE	A		

ANTENNA POLARITY & TEST DISTANCE: HORIZONTAL AT 3 M

NO.	FREQ. (MHz)	EMISSION LEVEL (dBuV/m)	LIMIT (dBuV/m)	MARGIN (dB)	ANTENNA HEIGHT (m)	TABLE ANGLE (Degree)	RAW VALUE (dBuV)	CORRECTION FACTOR (dB/m)
1	5150.00	58.7 PK	74.0	-15.3	1.09 H	357	20.39	38.35
2	5150.00	48.2 AV	54.0	-5.8	1.09 H	357	9.88	38.35
3	*5270.00	117.7 PK			1.09 H	357	79.15	38.53
4	*5270.00	107.4 AV			1.09 H	357	68.88	38.53
5	#10540.00	59.4 PK	88.3	-28.9	1.00 H	301	10.04	49.37

ANTENNA POLARITY & TEST DISTANCE: VERTICAL AT 3 M

NO.	FREQ. (MHz)	EMISSION LEVEL (dBuV/m)	LIMIT (dBuV/m)	MARGIN (dB)	ANTENNA HEIGHT (m)	TABLE ANGLE (Degree)	RAW VALUE (dBuV)	CORRECTION FACTOR (dB/m)
1	5150.00	58.9 PK	74.0	-15.1	1.08 V	3	20.51	38.35
2	5150.00	48.4 AV	54.0	-5.6	1.08 V	3	10.04	38.35
3	*5270.00	118.3 PK			1.08 V	3	79.81	38.53
4	*5270.00	107.0 AV			1.08 V	3	68.48	38.53
5	#10540.00	59.4 PK	88.3	-28.9	1.00 V	19	10.01	49.37

- REMARKS:**
1. Emission level (dBuV/m) = Raw Value (dBuV) + Correction Factor (dB/m).
  2. Correction Factor (dB/m) = Antenna Factor (dB/m) + Cable Factor (dB).
  3. The other emission levels were very low against the limit.
  4. Margin value = Emission level – Limit value.
  5. “ \* “: Fundamental frequency.
  6. “#”:The radiated frequency is out the restricted band.



A D T

EUT TEST CONDITION		MEASUREMENT DETAIL	
CHANNEL	Channel 62	FREQUENCY RANGE	1 ~ 40GHz
INPUT POWER	120Vac, 60Hz	DETECTOR FUNCTION	Peak (PK) Average (AV)
ENVIRONMENTAL CONDITIONS	28deg. C, 75%R H 1009hPa	TESTED BY	Chad Lee
TEST MODE	A		

ANTENNA POLARITY & TEST DISTANCE: HORIZONTAL AT 3 M								
NO.	FREQ. (MHz)	EMISSION LEVEL (dBuV/m)	LIMIT (dBuV/m)	MARGIN (dB)	ANTENNA HEIGHT (m)	TABLE ANGLE (Degree)	RAW VALUE (dBuV)	CORRECTION FACTOR (dB/m)
1	*5310.00	110.4 PK			1.00 H	350	71.83	38.57
2	*5310.00	100.6 AV			1.00 H	350	62.01	38.57
3	5350.00	70.0 PK	74.0	-4.0	1.00 H	350	31.39	38.63
4	5350.00	53.3 AV	54.0	-0.7	1.00 H	350	14.69	38.63
5	10620.00	60.2 PK	74.0	-13.8	1.00 H	306	10.63	49.52
6	10620.00	46.8 AV	54.0	-7.2	1.00 H	306	-2.73	49.52
ANTENNA POLARITY & TEST DISTANCE: VERTICAL AT 3 M								
NO.	FREQ. (MHz)	EMISSION LEVEL (dBuV/m)	LIMIT (dBuV/m)	MARGIN (dB)	ANTENNA HEIGHT (m)	TABLE ANGLE (Degree)	RAW VALUE (dBuV)	CORRECTION FACTOR (dB/m)
1	*5310.00	110.6 PK			1.08 V	355	72.07	38.57
2	*5310.00	100.7 AV			1.08 V	355	62.14	38.57
3	5350.00	70.6 PK	74.0	-3.4	1.08 V	355	31.96	38.63
4	5350.00	53.5 AV	54.0	-0.5	1.08 V	355	14.86	38.63
5	10620.00	59.2 PK	74.0	-14.8	1.00 V	1	9.70	49.52
6	10620.00	46.5 AV	54.0	-7.5	1.00 V	1	-3.06	49.52

- REMARKS:**
1. Emission level (dBuV/m) = Raw Value (dBuV) + Correction Factor (dB/m).
  2. Correction Factor (dB/m) = Antenna Factor (dB/m) + Cable Factor (dB).
  3. The other emission levels were very low against the limit.
  4. Margin value = Emission level – Limit value.
  5. “ \* “: Fundamental frequency.





A D T

EUT TEST CONDITION		MEASUREMENT DETAIL	
CHANNEL	Channel 102	FREQUENCY RANGE	1 ~ 40GHz
INPUT POWER	120Vac, 60Hz	DETECTOR FUNCTION	Peak (PK) Average (AV)
ENVIRONMENTAL CONDITIONS	28deg. C, 75%R H 1009hPa	TESTED BY	Chad Lee
TEST MODE	A		

ANTENNA POLARITY & TEST DISTANCE: HORIZONTAL AT 3 M								
NO.	FREQ. (MHz)	EMISSION LEVEL (dBuV/m)	LIMIT (dBuV/m)	MARGIN (dB)	ANTENNA HEIGHT (m)	TABLE ANGLE (Degree)	RAW VALUE (dBuV)	CORRECTION FACTOR (dB/m)
1	5460.00	71.2 PK	74.0	-2.8	1.05 H	359	32.36	38.84
2	5460.00	51.5 AV	54.0	-2.5	1.05 H	359	12.64	38.84
3	#5470.00	76.9 PK	88.3	-11.4	1.05 H	359	38.07	38.86
4	#5470.00	59.6 AV	68.3	-8.7	1.05 H	359	20.69	38.86
5	*5510.00	112.7 PK			1.05 H	359	73.71	38.94
6	*5510.00	100.6 AV			1.05 H	359	61.68	38.94
7	11020.00	60.7 PK	74.0	-13.3	1.05 H	20	10.43	50.28
8	11020.00	47.9 AV	54.0	-6.1	1.05 H	20	-2.35	50.28
ANTENNA POLARITY & TEST DISTANCE: VERTICAL AT 3 M								
NO.	FREQ. (MHz)	EMISSION LEVEL (dBuV/m)	LIMIT (dBuV/m)	MARGIN (dB)	ANTENNA HEIGHT (m)	TABLE ANGLE (Degree)	RAW VALUE (dBuV)	CORRECTION FACTOR (dB/m)
1	5460.00	73.0 PK	74.0	-1.0	1.00 V	357	34.11	38.84
2	5460.00	53.8 AV	54.0	-0.2	1.00 V	357	14.94	38.84
3	#5470.00	79.6 PK	88.3	-8.7	1.00 V	357	40.77	38.86
4	#5470.00	60.7 AV	68.3	-7.6	1.00 V	357	21.82	38.86
5	*5510.00	113.6 PK			1.00 V	357	74.67	38.94
6	*5510.00	101.8 AV			1.00 V	357	62.81	38.94
7	11020.00	58.6 PK	74.0	-15.4	1.17 V	18	8.28	50.28
8	11020.00	46.2 AV	54.0	-7.8	1.17 V	18	-4.12	50.28

- REMARKS:**
1. Emission level (dBuV/m) = Raw Value (dBuV) + Correction Factor (dB/m).
  2. Correction Factor (dB/m) = Antenna Factor (dB/m) + Cable Factor (dB).
  3. The other emission levels were very low against the limit.
  4. Margin value = Emission level – Limit value.
  5. “ \* “: Fundamental frequency.
  6. “#”:The radiated frequency is out the restricted band.



A D T

EUT TEST CONDITION		MEASUREMENT DETAIL	
CHANNEL	Channel 118	FREQUENCY RANGE	1 ~ 40GHz
INPUT POWER	120Vac, 60Hz	DETECTOR FUNCTION	Peak (PK) Average (AV)
ENVIRONMENTAL CONDITIONS	28deg. C, 75%R H 1009hPa	TESTED BY	Chad Lee
TEST MODE	A		

ANTENNA POLARITY & TEST DISTANCE: HORIZONTAL AT 3 M								
NO.	FREQ. (MHz)	EMISSION LEVEL (dBuV/m)	LIMIT (dBuV/m)	MARGIN (dB)	ANTENNA HEIGHT (m)	TABLE ANGLE (Degree)	RAW VALUE (dBuV)	CORRECTION FACTOR (dB/m)
1	*5590.00	117.3 PK			1.00 H	1	78.14	39.11
2	*5590.00	105.3 AV			1.00 H	1	66.22	39.11
3	11180.00	61.6 PK	74.0	-12.4	1.08 H	22	11.37	50.18
4	11180.00	48.6 AV	54.0	-5.4	1.08 H	22	-1.55	50.18
ANTENNA POLARITY & TEST DISTANCE: VERTICAL AT 3 M								
NO.	FREQ. (MHz)	EMISSION LEVEL (dBuV/m)	LIMIT (dBuV/m)	MARGIN (dB)	ANTENNA HEIGHT (m)	TABLE ANGLE (Degree)	RAW VALUE (dBuV)	CORRECTION FACTOR (dB/m)
1	*5590.00	116.7 PK			1.04 V	5	77.63	39.11
2	*5590.00	104.7 AV			1.04 V	5	65.62	39.11
3	11180.00	60.7 PK	74.0	-13.3	1.00 V	301	10.47	50.18
4	11180.00	47.9 AV	54.0	-6.1	1.00 V	301	-2.28	50.18

- REMARKS:**
1. Emission level (dBuV/m) = Raw Value (dBuV) + Correction Factor (dB/m).
  2. Correction Factor (dB/m) = Antenna Factor (dB/m) + Cable Factor (dB).
  3. The other emission levels were very low against the limit.
  4. Margin value = Emission level – Limit value.
  5. “ \* ”: Fundamental frequency.



A D T

EUT TEST CONDITION		MEASUREMENT DETAIL	
CHANNEL	Channel 134	FREQUENCY RANGE	1 ~ 40GHz
INPUT POWER	120Vac, 60Hz	DETECTOR FUNCTION	Peak (PK) Average (AV)
ENVIRONMENTAL CONDITIONS	28deg. C, 75%R H 1009hPa	TESTED BY	Chad Lee
TEST MODE	A		

**ANTENNA POLARITY & TEST DISTANCE: HORIZONTAL AT 3 M**

NO.	FREQ. (MHz)	EMISSION LEVEL (dBuV/m)	LIMIT (dBuV/m)	MARGIN (dB)	ANTENNA HEIGHT (m)	TABLE ANGLE (Degree)	RAW VALUE (dBuV)	CORRECTION FACTOR (dB/m)
1	*5670.00	114.9 PK			1.00 H	3	75.60	39.31
2	*5670.00	102.7 AV			1.00 H	3	63.41	39.31
3	#5725.00	65.6 PK	88.3	-22.7	1.00 H	3	26.16	39.45
4	#5725.00	45.2 AV	68.3	-23.1	1.00 H	3	5.77	39.45
5	11340.00	59.2 PK	74.0	-14.8	1.11 H	86	9.09	50.09
6	11340.00	47.9 AV	54.0	-6.1	1.11 H	86	-2.20	50.09

**ANTENNA POLARITY & TEST DISTANCE: VERTICAL AT 3 M**

NO.	FREQ. (MHz)	EMISSION LEVEL (dBuV/m)	LIMIT (dBuV/m)	MARGIN (dB)	ANTENNA HEIGHT (m)	TABLE ANGLE (Degree)	RAW VALUE (dBuV)	CORRECTION FACTOR (dB/m)
1	*5670.00	114.7 PK			1.00 V	358	75.42	39.31
2	*5670.00	102.5 AV			1.00 V	358	63.20	39.31
3	#5725.00	66.2 PK	88.3	-22.1	1.00 V	358	26.73	39.45
4	#5725.00	46.3 AV	68.3	-22.0	1.00 V	358	6.80	39.45
5	11340.00	59.7 PK	74.0	-14.3	1.06 V	320	9.61	50.09
6	11340.00	47.1 AV	54.0	-6.9	1.06 V	320	-2.95	50.09

- REMARKS:**
1. Emission level (dBuV/m) = Raw Value (dBuV) + Correction Factor (dB/m).
  2. Correction Factor (dB/m) = Antenna Factor (dB/m) + Cable Factor (dB).
  3. The other emission levels were very low against the limit.
  4. Margin value = Emission level – Limit value.
  5. “ \* “: Fundamental frequency.
  6. “#”:The radiated frequency is out the restricted band.



A D T

EUT TEST CONDITION		MEASUREMENT DETAIL	
CHANNEL	Channel 54	FREQUENCY RANGE	1 ~ 40GHz
INPUT POWER	120Vac, 60Hz	DETECTOR FUNCTION	Peak (PK) Average (AV)
ENVIRONMENTAL CONDITIONS	28deg. C, 75%R H 1009hPa	TESTED BY	Chad Lee
TEST MODE	C		

**ANTENNA POLARITY & TEST DISTANCE: HORIZONTAL AT 3 M**

NO.	FREQ. (MHz)	EMISSION LEVEL (dBuV/m)	LIMIT (dBuV/m)	MARGIN (dB)	ANTENNA HEIGHT (m)	TABLE ANGLE (Degree)	RAW VALUE (dBuV)	CORRECTION FACTOR (dB/m)
1	5150.00	59.4 PK	74.0	-14.6	1.00 H	356	21.03	38.35
2	5150.00	45.6 AV	54.0	-8.4	1.00 H	356	7.27	38.35
3	*5270.00	119.0 PK			1.00 H	356	80.45	38.53
4	*5270.00	108.6 AV			1.00 H	356	70.05	38.53
5	#10540.00	61.2 PK	88.3	-27.1	1.00 H	194	11.80	49.37

**ANTENNA POLARITY & TEST DISTANCE: VERTICAL AT 3 M**

NO.	FREQ. (MHz)	EMISSION LEVEL (dBuV/m)	LIMIT (dBuV/m)	MARGIN (dB)	ANTENNA HEIGHT (m)	TABLE ANGLE (Degree)	RAW VALUE (dBuV)	CORRECTION FACTOR (dB/m)
1	5150.00	58.2 PK	74.0	-15.8	1.00 V	355	19.82	38.35
2	5150.00	45.5 AV	54.0	-8.5	1.00 V	355	7.13	38.35
3	*5270.00	118.5 PK			1.00 V	355	80.01	38.53
4	*5270.00	108.5 AV			1.00 V	355	70.01	38.53
5	#10540.00	61.7 PK	88.3	-26.6	1.00 V	205	12.35	49.37

- REMARKS:**
1. Emission level (dBuV/m) = Raw Value (dBuV) + Correction Factor (dB/m).
  2. Correction Factor (dB/m) = Antenna Factor (dB/m) + Cable Factor (dB).
  3. The other emission levels were very low against the limit.
  4. Margin value = Emission level – Limit value.
  5. “ \* “: Fundamental frequency.
  6. “#”:The radiated frequency is out the restricted band.



A D T

EUT TEST CONDITION		MEASUREMENT DETAIL	
CHANNEL	Channel 62	FREQUENCY RANGE	1 ~ 40GHz
INPUT POWER	120Vac, 60Hz	DETECTOR FUNCTION	Peak (PK) Average (AV)
ENVIRONMENTAL CONDITIONS	28deg. C, 75%R H 1009hPa	TESTED BY	Chad Lee
TEST MODE	C		

ANTENNA POLARITY & TEST DISTANCE: HORIZONTAL AT 3 M								
NO.	FREQ. (MHz)	EMISSION LEVEL (dBuV/m)	LIMIT (dBuV/m)	MARGIN (dB)	ANTENNA HEIGHT (m)	TABLE ANGLE (Degree)	RAW VALUE (dBuV)	CORRECTION FACTOR (dB/m)
1	*5310.00	115.7 PK			1.00 H	354	77.12	38.57
2	*5310.00	104.7 AV			1.00 H	354	66.08	38.57
3	5350.00	68.9 PK	74.0	-5.1	1.00 H	354	30.24	38.63
4	5350.00	53.0 AV	54.0	-1.0	1.00 H	354	14.39	38.63
5	10620.00	62.6 PK	74.0	-11.4	1.00 H	6	13.07	49.52
6	10620.00	46.3 AV	54.0	-7.7	1.00 H	6	-3.24	49.52
ANTENNA POLARITY & TEST DISTANCE: VERTICAL AT 3 M								
NO.	FREQ. (MHz)	EMISSION LEVEL (dBuV/m)	LIMIT (dBuV/m)	MARGIN (dB)	ANTENNA HEIGHT (m)	TABLE ANGLE (Degree)	RAW VALUE (dBuV)	CORRECTION FACTOR (dB/m)
1	*5310.00	114.9 PK			1.00 V	357	76.28	38.57
2	*5310.00	104.2 AV			1.00 V	357	65.58	38.57
3	5350.00	68.9 PK	74.0	-5.1	1.00 V	357	30.28	38.63
4	5350.00	53.5 AV	54.0	-0.5	1.00 V	357	14.91	38.63
5	10620.00	63.0 PK	74.0	-11.0	1.00 V	106	13.44	49.52
6	10620.00	49.3 AV	54.0	-4.7	1.00 V	106	-0.21	49.52

- REMARKS:**
1. Emission level (dBuV/m) = Raw Value (dBuV) + Correction Factor (dB/m).
  2. Correction Factor (dB/m) = Antenna Factor (dB/m) + Cable Factor (dB).
  3. The other emission levels were very low against the limit.
  4. Margin value = Emission level – Limit value.
  5. “ \* “: Fundamental frequency.



A D T

EUT TEST CONDITION		MEASUREMENT DETAIL	
CHANNEL	Channel 102	FREQUENCY RANGE	1 ~ 40GHz
INPUT POWER	120Vac, 60Hz	DETECTOR FUNCTION	Peak (PK) Average (AV)
ENVIRONMENTAL CONDITIONS	28deg. C, 75%R H 1009hPa	TESTED BY	Chad Lee
TEST MODE	C		

**ANTENNA POLARITY & TEST DISTANCE: HORIZONTAL AT 3 M**

NO.	FREQ. (MHz)	EMISSION LEVEL (dBuV/m)	LIMIT (dBuV/m)	MARGIN (dB)	ANTENNA HEIGHT (m)	TABLE ANGLE (Degree)	RAW VALUE (dBuV)	CORRECTION FACTOR (dB/m)
1	5460.00	69.3 PK	74.0	-4.7	1.00 H	355	30.44	38.84
2	5460.00	53.8 AV	54.0	-0.2	1.00 H	355	14.94	38.84
3	#5470.00	71.9 PK	88.3	-16.4	1.00 H	355	33.01	38.86
4	#5470.00	56.4 AV	68.3	-11.9	1.00 H	355	17.49	38.86
5	*5510.00	118.9 PK			1.00 H	355	79.93	38.94
6	*5510.00	106.0 AV			1.00 H	355	67.04	38.94
7	11020.00	61.7 PK	74.0	-12.3	1.00 H	6	11.41	50.28
8	11020.00	49.5 AV	54.0	-4.5	1.00 H	6	-0.78	50.28

**ANTENNA POLARITY & TEST DISTANCE: VERTICAL AT 3 M**

NO.	FREQ. (MHz)	EMISSION LEVEL (dBuV/m)	LIMIT (dBuV/m)	MARGIN (dB)	ANTENNA HEIGHT (m)	TABLE ANGLE (Degree)	RAW VALUE (dBuV)	CORRECTION FACTOR (dB/m)
1	5460.00	66.1 PK	74.0	-7.9	1.00 V	357	27.22	38.84
2	5460.00	51.3 AV	54.0	-2.7	1.00 V	357	12.42	38.84
3	#5470.00	71.4 PK	88.3	-16.9	1.00 V	357	32.54	38.86
4	#5470.00	55.3 AV	68.3	-13.0	1.00 V	357	16.43	38.86
5	*5510.00	118.0 PK			1.00 V	357	79.07	38.94
6	*5510.00	106.9 AV			1.00 V	357	68.00	38.94
7	11020.00	65.1 PK	74.0	-8.9	1.00 V	82	14.86	50.28
8	11020.00	51.8 AV	54.0	-2.2	1.00 V	82	1.56	50.28

- REMARKS:**
1. Emission level (dBuV/m) = Raw Value (dBuV) + Correction Factor (dB/m).
  2. Correction Factor (dB/m) = Antenna Factor (dB/m) + Cable Factor (dB).
  3. The other emission levels were very low against the limit.
  4. Margin value = Emission level – Limit value.
  5. “ \* “: Fundamental frequency.
  6. “#”:The radiated frequency is out the restricted band.



A D T

EUT TEST CONDITION		MEASUREMENT DETAIL	
CHANNEL	Channel 118	FREQUENCY RANGE	1 ~ 40GHz
INPUT POWER	120Vac, 60Hz	DETECTOR FUNCTION	Peak (PK) Average (AV)
ENVIRONMENTAL CONDITIONS	28deg. C, 75%R H 1009hPa	TESTED BY	Chad Lee
TEST MODE	C		

ANTENNA POLARITY & TEST DISTANCE: HORIZONTAL AT 3 M								
NO.	FREQ. (MHz)	EMISSION LEVEL (dBuV/m)	LIMIT (dBuV/m)	MARGIN (dB)	ANTENNA HEIGHT (m)	TABLE ANGLE (Degree)	RAW VALUE (dBuV)	CORRECTION FACTOR (dB/m)
1	*5590.00	116.7 PK			1.00 H	357	77.54	39.11
2	*5590.00	106.9 AV			1.00 H	357	67.81	39.11
3	11180.00	61.3 PK	74.0	-12.7	1.00 H	174	11.09	50.18
4	11180.00	47.5 AV	54.0	-6.5	1.00 H	174	-2.69	50.18
ANTENNA POLARITY & TEST DISTANCE: VERTICAL AT 3 M								
NO.	FREQ. (MHz)	EMISSION LEVEL (dBuV/m)	LIMIT (dBuV/m)	MARGIN (dB)	ANTENNA HEIGHT (m)	TABLE ANGLE (Degree)	RAW VALUE (dBuV)	CORRECTION FACTOR (dB/m)
1	*5590.00	116.5 PK			1.00 V	358	77.41	39.11
2	*5590.00	106.6 AV			1.00 V	358	67.44	39.11
3	11180.00	62.1 PK	74.0	-11.9	1.00 V	84	11.87	50.18
4	11180.00	49.7 AV	54.0	-4.3	1.00 V	84	-0.52	50.18

- REMARKS:**
1. Emission level (dBuV/m) = Raw Value (dBuV) + Correction Factor (dB/m).
  2. Correction Factor (dB/m) = Antenna Factor (dB/m) + Cable Factor (dB).
  3. The other emission levels were very low against the limit.
  4. Margin value = Emission level – Limit value.
  5. “ \* “: Fundamental frequency.



A D T

EUT TEST CONDITION		MEASUREMENT DETAIL	
CHANNEL	Channel 134	FREQUENCY RANGE	1 ~ 40GHz
INPUT POWER	120Vac, 60Hz	DETECTOR FUNCTION	Peak (PK) Average (AV)
ENVIRONMENTAL CONDITIONS	28deg. C, 75%R H 1009hPa	TESTED BY	Chad Lee
TEST MODE	C		

ANTENNA POLARITY & TEST DISTANCE: HORIZONTAL AT 3 M								
NO.	FREQ. (MHz)	EMISSION LEVEL (dBuV/m)	LIMIT (dBuV/m)	MARGIN (dB)	ANTENNA HEIGHT (m)	TABLE ANGLE (Degree)	RAW VALUE (dBuV)	CORRECTION FACTOR (dB/m)
1	*5670.00	117.1 PK			1.00 H	357	77.79	39.31
2	*5670.00	106.8 AV			1.00 H	357	67.52	39.31
3	#5725.00	60.5 PK	88.3	-27.8	1.00 H	357	21.09	39.45
4	#5725.00	47.8 AV	68.3	-20.5	1.00 H	357	8.38	39.45
5	11340.00	60.8 PK	74.0	-13.2	1.00 H	6	10.66	50.09
6	11340.00	48.3 AV	54.0	-5.7	1.00 H	6	-1.81	50.09
ANTENNA POLARITY & TEST DISTANCE: VERTICAL AT 3 M								
NO.	FREQ. (MHz)	EMISSION LEVEL (dBuV/m)	LIMIT (dBuV/m)	MARGIN (dB)	ANTENNA HEIGHT (m)	TABLE ANGLE (Degree)	RAW VALUE (dBuV)	CORRECTION FACTOR (dB/m)
1	*5670.00	117.1 PK			1.00 V	357	77.74	39.31
2	*5670.00	106.7 AV			1.00 V	357	67.43	39.31
3	#5725.00	62.7 PK	88.3	-25.6	1.00 V	356	23.22	39.45
4	#5725.00	48.3 AV	68.3	-20.0	1.00 V	356	8.88	39.45
5	11340.00	62.6 PK	74.0	-11.7	1.00 V	91	12.52	50.09
6	11340.00	50.2 AV	54.0	-3.8	1.00 V	91	0.15	50.09

- REMARKS:**
1. Emission level (dBuV/m) = Raw Value (dBuV) + Correction Factor (dB/m).
  2. Correction Factor (dB/m) = Antenna Factor (dB/m) + Cable Factor (dB).
  3. The other emission levels were very low against the limit.
  4. Margin value = Emission level – Limit value.
  5. “ \* “: Fundamental frequency.
  6. “#”:The radiated frequency is out the restricted band.





A D T

**BELOW 1GHz WORST-CASE DATA : 802.11n (20MHz)**

EUT TEST CONDITION		MEASUREMENT DETAIL	
CHANNEL	Channel 64	FREQUENCY RANGE	Below 1000MHz
INPUT POWER	120Vac, 60Hz	DETECTOR FUNCTION	Quasi-Peak
ENVIRONMENTAL CONDITIONS	23deg. C, 76% RH 1010hPa	TESTED BY	Chad Lee
TEST MODE	A		

ANTENNA POLARITY & TEST DISTANCE: HORIZONTAL AT 3 M								
NO.	FREQ. (MHz)	EMISSION LEVEL (dBuV/m)	LIMIT (dBuV/m)	MARGIN (dB)	ANTENNA HEIGHT (m)	TABLE ANGLE (Degree)	RAW VALUE (dBuV)	CORRECTION FACTOR (dB/m)
1	38.40	38.9 QP	40.0	-1.1	1.00 H	352	24.49	14.41
2	63.21	39.0 QP	40.0	-1.0	1.00 H	207	31.52	7.49
3	87.45	38.0 QP	40.0	-2.0	1.00 H	91	28.05	9.98
4	125.00	41.8 QP	43.5	-1.7	1.00 H	222	28.99	12.77
5	625.01	42.8 QP	46.0	-3.2	1.70 H	353	17.47	25.33
6	875.00	42.1 QP	46.0	-3.9	1.48 H	182	13.36	28.75
ANTENNA POLARITY & TEST DISTANCE: VERTICAL AT 3 M								
NO.	FREQ. (MHz)	EMISSION LEVEL (dBuV/m)	LIMIT (dBuV/m)	MARGIN (dB)	ANTENNA HEIGHT (m)	TABLE ANGLE (Degree)	RAW VALUE (dBuV)	CORRECTION FACTOR (dB/m)
1	38.38	38.9 QP	40.0	-1.1	1.00 V	147	24.44	14.42
2	63.20	38.9 QP	40.0	-1.1	1.00 V	101	31.38	7.49
3	87.44	37.9 QP	40.0	-2.1	1.00 V	72	27.96	9.98
4	125.01	41.5 QP	43.5	-2.0	1.00 V	108	28.77	12.77
5	625.01	41.8 QP	46.0	-4.2	1.48 V	344	16.43	25.33
6	875.00	41.0 QP	46.0	-5.0	1.37 V	106	12.29	28.75

- REMARKS:**
1. Emission level (dBuV/m) = Raw Value (dBuV) + Correction Factor (dB/m).
  2. Correction Factor (dB/m) = Antenna Factor (dB/m) + Cable Factor (dB).
  3. The other emission levels were very low against the limit.
  4. Margin value = Emission level – Limit value.



A D T

EUT TEST CONDITION		MEASUREMENT DETAIL	
CHANNEL	Channel 100	FREQUENCY RANGE	Below 1000MHz
INPUT POWER	120Vac, 60Hz	DETECTOR FUNCTION	Quasi-Peak
ENVIRONMENTAL CONDITIONS	23deg. C, 76% RH 1010hPa	TESTED BY	Chad Lee
TEST MODE	A		

ANTENNA POLARITY & TEST DISTANCE: HORIZONTAL AT 3 M								
NO.	FREQ. (MHz)	EMISSION LEVEL (dBuV/m)	LIMIT (dBuV/m)	MARGIN (dB)	ANTENNA HEIGHT (m)	TABLE ANGLE (Degree)	RAW VALUE (dBuV)	CORRECTION FACTOR (dB/m)
1	38.40	38.9 QP	40.0	-1.1	1.00 H	357	24.51	14.41
2	63.20	39.1 QP	40.0	-0.9	1.00 H	203	31.65	7.49
3	87.41	38.0 QP	40.0	-2.0	1.00 H	95	28.01	9.97
4	125.01	41.6 QP	43.5	-1.9	1.00 H	122	28.86	12.77
5	625.00	42.7 QP	46.0	-3.3	1.73 H	320	17.41	25.33
6	875.00	42.2 QP	46.0	-3.8	1.27 H	161	13.40	28.75
ANTENNA POLARITY & TEST DISTANCE: VERTICAL AT 3 M								
NO.	FREQ. (MHz)	EMISSION LEVEL (dBuV/m)	LIMIT (dBuV/m)	MARGIN (dB)	ANTENNA HEIGHT (m)	TABLE ANGLE (Degree)	RAW VALUE (dBuV)	CORRECTION FACTOR (dB/m)
1	38.39	38.7 QP	40.0	-1.3	1.00 V	247	24.26	14.42
2	63.19	39.2 QP	40.0	-0.8	1.00 V	102	31.72	7.49
3	87.41	38.0 QP	40.0	-2.0	1.00 V	93	28.02	9.97
4	125.00	41.3 QP	43.5	-2.2	1.00 V	113	28.53	12.77
5	625.00	41.6 QP	46.0	-4.4	1.73 V	328	16.28	25.33
6	875.00	42.1 QP	46.0	-3.9	1.15 V	149	13.37	28.75

- REMARKS:**
1. Emission level (dBuV/m) = Raw Value (dBuV) + Correction Factor (dB/m).
  2. Correction Factor (dB/m) = Antenna Factor (dB/m) + Cable Factor (dB).
  3. The other emission levels were very low against the limit.
  4. Margin value = Emission level – Limit value.



A D T

EUT TEST CONDITION		MEASUREMENT DETAIL	
CHANNEL	Channel 64	FREQUENCY RANGE	Below 1000MHz
INPUT POWER	120Vac, 60Hz	DETECTOR FUNCTION	Quasi-Peak
ENVIRONMENTAL CONDITIONS	23deg. C, 76% RH 1010hPa	TESTED BY	Chad Lee
TEST MODE	B		

ANTENNA POLARITY & TEST DISTANCE: HORIZONTAL AT 3 M								
NO.	FREQ. (MHz)	EMISSION LEVEL (dBuV/m)	LIMIT (dBuV/m)	MARGIN (dB)	ANTENNA HEIGHT (m)	TABLE ANGLE (Degree)	RAW VALUE (dBuV)	CORRECTION FACTOR (dB/m)
1	125.01	43.0 QP	43.5	-0.5	1.84 H	301	30.21	12.77
2	250.00	39.7 QP	46.0	-6.3	2.15 H	171	24.09	15.56
3	501.30	40.1 QP	46.0	-5.9	2.52 H	240	16.73	23.34
4	625.80	37.8 QP	46.0	-8.2	2.62 H	313	12.47	25.34
5	751.00	42.4 QP	46.0	-3.6	2.44 H	74	15.59	26.81
6	875.00	38.6 QP	46.0	-7.4	1.85 H	255	9.85	28.75
ANTENNA POLARITY & TEST DISTANCE: VERTICAL AT 3 M								
NO.	FREQ. (MHz)	EMISSION LEVEL (dBuV/m)	LIMIT (dBuV/m)	MARGIN (dB)	ANTENNA HEIGHT (m)	TABLE ANGLE (Degree)	RAW VALUE (dBuV)	CORRECTION FACTOR (dB/m)
1	250.00	36.1 QP	46.0	-9.9	1.00 V	268	20.52	15.56
2	526.00	41.4 QP	46.0	-4.6	1.16 V	231	17.53	23.83
3	576.30	44.7 QP	46.0	-1.3	1.34 V	358	19.95	24.72
4	676.00	40.5 QP	46.0	-5.5	1.00 V	127	14.73	25.77
5	725.50	33.0 QP	46.0	-13.0	1.26 V	39	6.59	26.37
6	875.00	39.4 QP	46.0	-6.6	1.00 V	20	10.60	28.75

- REMARKS:**
1. Emission level (dBuV/m) = Raw Value (dBuV) + Correction Factor (dB/m).
  2. Correction Factor (dB/m) = Antenna Factor (dB/m) + Cable Factor (dB).
  3. The other emission levels were very low against the limit.
  4. Margin value = Emission level – Limit value.



A D T

EUT TEST CONDITION		MEASUREMENT DETAIL	
CHANNEL	Channel 100	FREQUENCY RANGE	Below 1000MHz
INPUT POWER	120Vac, 60Hz	DETECTOR FUNCTION	Quasi-Peak
ENVIRONMENTAL CONDITIONS	23deg. C, 76% RH 1010hPa	TESTED BY	Chad Lee
TEST MODE	B		

ANTENNA POLARITY & TEST DISTANCE: HORIZONTAL AT 3 M								
NO.	FREQ. (MHz)	EMISSION LEVEL (dBuV/m)	LIMIT (dBuV/m)	MARGIN (dB)	ANTENNA HEIGHT (m)	TABLE ANGLE (Degree)	RAW VALUE (dBuV)	CORRECTION FACTOR (dB/m)
1	125.01	42.9 QP	43.5	-0.6	1.88 H	297	30.09	12.77
2	250.00	39.5 QP	46.0	-6.5	1.92 H	166	23.91	15.56
3	501.27	40.0 QP	46.0	-6.0	2.44 H	236	16.70	23.34
4	625.76	37.7 QP	46.0	-8.3	2.59 H	302	12.31	25.34
5	751.01	42.4 QP	46.0	-3.6	1.31 H	72	15.56	26.81
6	875.00	38.4 QP	46.0	-7.6	1.79 H	250	9.64	28.75
ANTENNA POLARITY & TEST DISTANCE: VERTICAL AT 3 M								
NO.	FREQ. (MHz)	EMISSION LEVEL (dBuV/m)	LIMIT (dBuV/m)	MARGIN (dB)	ANTENNA HEIGHT (m)	TABLE ANGLE (Degree)	RAW VALUE (dBuV)	CORRECTION FACTOR (dB/m)
1	250.01	36.0 QP	46.0	-10.0	1.00 V	259	20.48	15.56
2	526.00	40.3 QP	46.0	-5.7	1.28 V	227	16.50	23.83
3	576.32	43.5 QP	46.0	-2.5	1.35 V	248	18.73	24.72
4	676.00	40.4 QP	46.0	-5.6	1.00 V	116	14.66	25.77
5	725.50	32.8 QP	46.0	-13.2	1.14 V	35	6.45	26.37
6	875.00	38.3 QP	46.0	-7.7	1.00 V	18	9.50	28.75

- REMARKS:**
1. Emission level (dBuV/m) = Raw Value (dBuV) + Correction Factor (dB/m).
  2. Correction Factor (dB/m) = Antenna Factor (dB/m) + Cable Factor (dB).
  3. The other emission levels were very low against the limit.
  4. Margin value = Emission level – Limit value.



A D T

EUT TEST CONDITION		MEASUREMENT DETAIL	
CHANNEL	Channel 64	FREQUENCY RANGE	Below 1000MHz
INPUT POWER	120Vac, 60Hz	DETECTOR FUNCTION	Quasi-Peak
ENVIRONMENTAL CONDITIONS	23deg. C, 76% RH 1010hPa	TESTED BY	Chad Lee
TEST MODE	C		

ANTENNA POLARITY & TEST DISTANCE: HORIZONTAL AT 3 M								
NO.	FREQ. (MHz)	EMISSION LEVEL (dBuV/m)	LIMIT (dBuV/m)	MARGIN (dB)	ANTENNA HEIGHT (m)	TABLE ANGLE (Degree)	RAW VALUE (dBuV)	CORRECTION FACTOR (dB/m)
1	78.58	31.7 QP	40.0	-8.3	1.14 H	0	22.84	8.81
2	125.01	42.5 QP	43.5	-1.0	2.50 H	244	29.69	12.77
3	250.00	45.9 QP	46.0	-0.1	1.60 H	250	30.33	15.56
4	375.00	30.4 QP	46.0	-15.6	2.05 H	313	11.14	19.23
5	500.00	37.4 QP	46.0	-8.6	1.82 H	188	14.04	23.31
6	875.00	40.2 QP	46.0	-5.8	1.93 H	117	11.44	28.76
ANTENNA POLARITY & TEST DISTANCE: VERTICAL AT 3 M								
NO.	FREQ. (MHz)	EMISSION LEVEL (dBuV/m)	LIMIT (dBuV/m)	MARGIN (dB)	ANTENNA HEIGHT (m)	TABLE ANGLE (Degree)	RAW VALUE (dBuV)	CORRECTION FACTOR (dB/m)
1	65.38	35.7 QP	40.0	-4.3	1.00 V	200	28.06	7.59
2	125.00	42.4 QP	43.5	-1.1	1.00 V	236	29.58	12.77
3	250.00	34.6 QP	46.0	-11.4	1.00 V	62	19.03	15.56
4	500.01	45.3 QP	46.0	-0.7	1.15 V	113	22.01	23.31
5	625.01	45.1 QP	46.0	-0.9	1.00 V	20	19.74	25.33
6	751.00	41.6 QP	46.0	-4.4	1.00 V	124	14.83	26.81

- REMARKS:**
1. Emission level (dBuV/m) = Raw Value (dBuV) + Correction Factor (dB/m).
  2. Correction Factor (dB/m) = Antenna Factor (dB/m) + Cable Factor (dB).
  3. The other emission levels were very low against the limit.
  4. Margin value = Emission level – Limit value.



A D T

EUT TEST CONDITION		MEASUREMENT DETAIL	
CHANNEL	Channel 100	FREQUENCY RANGE	Below 1000MHz
INPUT POWER	120Vac, 60Hz	DETECTOR FUNCTION	Quasi-Peak
ENVIRONMENTAL CONDITIONS	23deg. C, 76% RH 1010hPa	TESTED BY	Chad Lee
TEST MODE	C		

ANTENNA POLARITY & TEST DISTANCE: HORIZONTAL AT 3 M								
NO.	FREQ. (MHz)	EMISSION LEVEL (dBuV/m)	LIMIT (dBuV/m)	MARGIN (dB)	ANTENNA HEIGHT (m)	TABLE ANGLE (Degree)	RAW VALUE (dBuV)	CORRECTION FACTOR (dB/m)
1	78.59	31.6 QP	40.0	-8.4	1.04 H	0	22.75	8.81
2	125.00	42.5 QP	43.5	-1.0	2.48 H	236	29.70	12.77
3	250.01	45.7 QP	46.0	-0.3	1.60 H	149	30.11	15.56
4	375.00	30.1 QP	46.0	-15.9	2.02 H	206	10.88	19.23
5	500.00	37.2 QP	46.0	-8.8	1.78 H	169	13.89	23.31
6	875.00	40.1 QP	46.0	-5.9	1.75 H	116	11.31	28.75
ANTENNA POLARITY & TEST DISTANCE: VERTICAL AT 3 M								
NO.	FREQ. (MHz)	EMISSION LEVEL (dBuV/m)	LIMIT (dBuV/m)	MARGIN (dB)	ANTENNA HEIGHT (m)	TABLE ANGLE (Degree)	RAW VALUE (dBuV)	CORRECTION FACTOR (dB/m)
1	65.39	35.6 QP	40.0	-4.4	1.00 V	101	27.97	7.59
2	125.01	41.5 QP	43.5	-2.0	1.00 V	256	28.71	12.77
3	250.01	34.6 QP	46.0	-11.4	1.00 V	51	19.06	15.56
4	500.00	44.6 QP	46.0	-1.4	1.04 V	124	21.32	23.31
5	625.01	45.0 QP	46.0	-1.0	1.00 V	18	19.66	25.33
6	751.00	41.8 QP	46.0	-4.2	1.00 V	127	14.94	26.81

- REMARKS:**
1. Emission level (dBuV/m) = Raw Value (dBuV) + Correction Factor (dB/m).
  2. Correction Factor (dB/m) = Antenna Factor (dB/m) + Cable Factor (dB).
  3. The other emission levels were very low against the limit.
  4. Margin value = Emission level – Limit value.



A D T

EUT TEST CONDITION		MEASUREMENT DETAIL	
CHANNEL	Channel 64	FREQUENCY RANGE	Below 1000MHz
INPUT POWER	120Vac, 60Hz	DETECTOR FUNCTION	Quasi-Peak
ENVIRONMENTAL CONDITIONS	23deg. C, 76% RH 1010hPa	TESTED BY	Chad Lee
TEST MODE	D		

ANTENNA POLARITY & TEST DISTANCE: HORIZONTAL AT 3 M								
NO.	FREQ. (MHz)	EMISSION LEVEL (dBuV/m)	LIMIT (dBuV/m)	MARGIN (dB)	ANTENNA HEIGHT (m)	TABLE ANGLE (Degree)	RAW VALUE (dBuV)	CORRECTION FACTOR (dB/m)
1	36.39	34.2 QP	40.0	-5.8	2.55 H	17	18.87	15.31
2	87.13	39.5 QP	40.0	-0.5	2.29 H	100	29.58	9.94
3	250.00	45.0 QP	46.0	-1.0	1.55 H	109	29.40	15.56
4	500.00	36.8 QP	46.0	-9.2	1.05 H	144	13.47	23.31
5	625.00	34.6 QP	46.0	-11.4	1.17 H	66	9.22	25.33
6	750.00	30.2 QP	46.0	-15.8	1.00 H	11	3.36	26.79
ANTENNA POLARITY & TEST DISTANCE: VERTICAL AT 3 M								
NO.	FREQ. (MHz)	EMISSION LEVEL (dBuV/m)	LIMIT (dBuV/m)	MARGIN (dB)	ANTENNA HEIGHT (m)	TABLE ANGLE (Degree)	RAW VALUE (dBuV)	CORRECTION FACTOR (dB/m)
1	36.31	34.6 QP	40.0	-5.4	1.01 V	72	19.20	15.35
2	86.46	38.6 QP	40.0	-1.4	1.00 V	0	28.71	9.85
3	250.00	42.6 QP	46.0	-3.4	1.08 V	165	26.99	15.56
4	500.00	35.2 QP	46.0	-10.8	1.06 V	179	11.87	23.31
5	625.00	30.1 QP	46.0	-15.9	1.25 V	187	4.78	25.33
6	750.00	31.9 QP	46.0	-14.1	1.79 V	101	5.08	26.79

- REMARKS:**
1. Emission level (dBuV/m) = Raw Value (dBuV) + Correction Factor (dB/m).
  2. Correction Factor (dB/m) = Antenna Factor (dB/m) + Cable Factor (dB).
  3. The other emission levels were very low against the limit.
  4. Margin value = Emission level – Limit value.



A D T

EUT TEST CONDITION		MEASUREMENT DETAIL	
CHANNEL	Channel 100	FREQUENCY RANGE	Below 1000MHz
INPUT POWER	120Vac, 60Hz	DETECTOR FUNCTION	Quasi-Peak
ENVIRONMENTAL CONDITIONS	23deg. C, 76% RH 1010hPa	TESTED BY	Chad Lee
TEST MODE	D		

ANTENNA POLARITY & TEST DISTANCE: HORIZONTAL AT 3 M								
NO.	FREQ. (MHz)	EMISSION LEVEL (dBuV/m)	LIMIT (dBuV/m)	MARGIN (dB)	ANTENNA HEIGHT (m)	TABLE ANGLE (Degree)	RAW VALUE (dBuV)	CORRECTION FACTOR (dB/m)
1	36.32	33.9 QP	40.0	-6.1	2.27 H	14	18.55	15.34
2	87.15	39.0 QP	40.0	-1.0	2.31 H	100	29.04	9.94
3	250.00	45.0 QP	46.0	-1.0	1.55 H	109	29.42	15.56
4	500.00	38.0 QP	46.0	-8.0	1.09 H	152	14.68	23.31
5	625.00	35.1 QP	46.0	-10.9	1.05 H	147	9.81	25.33
6	750.00	30.9 QP	46.0	-15.1	1.00 H	18	4.10	26.79
ANTENNA POLARITY & TEST DISTANCE: VERTICAL AT 3 M								
NO.	FREQ. (MHz)	EMISSION LEVEL (dBuV/m)	LIMIT (dBuV/m)	MARGIN (dB)	ANTENNA HEIGHT (m)	TABLE ANGLE (Degree)	RAW VALUE (dBuV)	CORRECTION FACTOR (dB/m)
1	36.34	34.7 QP	40.0	-5.3	1.00 V	79	19.41	15.33
2	87.16	38.5 QP	40.0	-1.5	1.00 V	14	28.58	9.94
3	250.01	42.5 QP	46.0	-3.5	1.28 V	133	26.98	15.56
4	500.01	35.0 QP	46.0	-11.0	1.27 V	52	11.65	23.31
5	625.00	30.8 QP	46.0	-15.2	1.35 V	9	5.49	25.33
6	750.00	30.3 QP	46.0	-15.7	1.00 V	58	3.54	26.79

- REMARKS:**
1. Emission level (dBuV/m) = Raw Value (dBuV) + Correction Factor (dB/m).
  2. Correction Factor (dB/m) = Antenna Factor (dB/m) + Cable Factor (dB).
  3. The other emission levels were very low against the limit.
  4. Margin value = Emission level – Limit value.



## 4.2 CONDUCTED EMISSION MEASUREMENT

### 4.2.1 LIMITS OF CONDUCTED EMISSION MEASUREMENT

FREQUENCY OF EMISSION (MHz)	CONDUCTED LIMIT (dB $\mu$ V)	
	Quasi-peak	Average
0.15 ~ 0.5	66 to 56	56 to 46
0.5 ~ 5	56	46
5 ~ 30	60	50

- NOTE:**
1. The lower limit shall apply at the transition frequencies.
  2. The limit decreases in line with the logarithm of the frequency in the range of 0.15 to 0.50MHz.
  3. All emanations from a class A/B digital device or system, including any network of conductors and apparatus connected thereto, shall not exceed the level of field strengths specified above.

### 4.2.2 TEST INSTRUMENTS

DESCRIPTION & MANUFACTURER	MODEL NO.	SERIAL NO.	CALIBRATED DATE	CALIBRATED UNTIL
ROHDE & SCHWARZ Test Receiver	ESCS 30	838251/021	Mar. 05, 2009	Mar. 04, 2010
ROHDE & SCHWARZ Artificial Mains Network (for EUT)	ESH3-Z5	100218	Nov. 26, 2008	Nov. 25, 2009
LISN With Adapter (for EUT)	AD10	C10Ada-001	Nov. 26, 2008	Nov. 25, 2009
ROHDE & SCHWARZ Artificial Mains Network (for peripherals)	ESH3-Z5	100219	Nov. 20, 2008	Nov. 19, 2009
Software	ADT_Cond_V7.3.7	NA	NA	NA
Software	ADT_ISN_V7.3.7	NA	NA	NA
RF cable (JYEBAO)	5D-FB	Cable-C10.01	Feb. 26, 2009	Feb. 25, 2010
SUHNER Terminator (For ROHDE & SCHWARZ LISN)	65BNC-5001	E1-010773	Feb. 27, 2009	Feb. 26, 2010

- NOTE:**
1. The calibration interval of the above test instruments is 12 months and the calibrations are traceable to NML/ROC and NIST/USA.
  2. The test was performed in Shielded Room No. 10.
  3. The VCCI Site Registration No. C-1852.

#### 4.2.3 TEST PROCEDURES

- a. The EUT was placed 0.4 meters from the conducting wall of the shielded room with EUT being connected to the power mains through a line impedance stabilization network (LISN). Other support units were connected to the power mains through another LISN. The two LISNs provide 50 ohm/ 50uH of coupling impedance for the measuring instrument.
- b. Both lines of the power mains connected to the EUT were checked for maximum conducted interference.
- c. The frequency range from 150kHz to 30MHz was searched. Emission levels under (Limit - 20dB) was not recorded.

#### 4.2.4 DEVIATION FROM TEST STANDARD

No deviation

#### 4.2.5 TEST SETUP

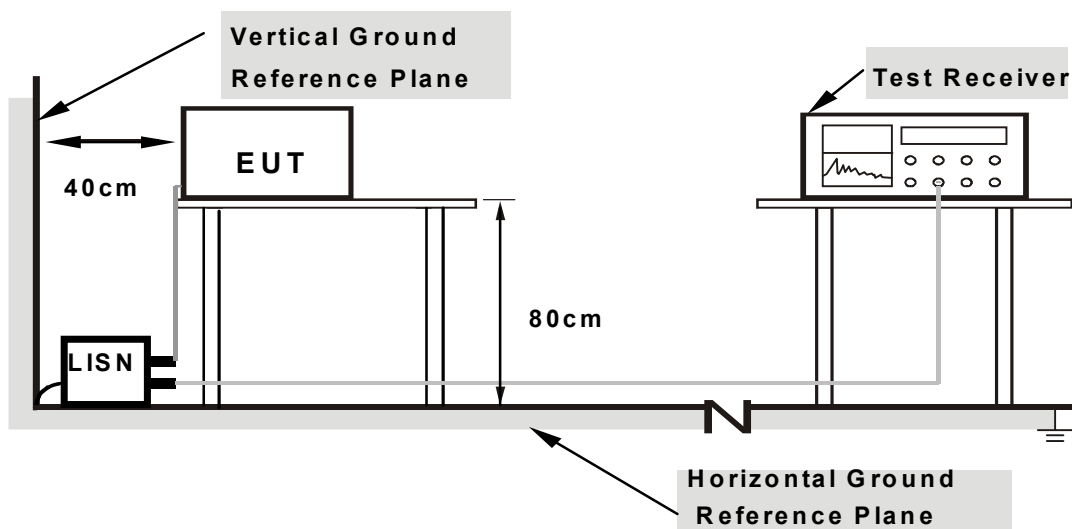

**Note: 1. Support units were connected to second LISN.**

**2. Both of LISNs (AMN) are 80 cm from EUT and at least 80 from other units and other metal planes**

For the actual test configuration, please refer to the attached file (Test Setup Photo).

#### 4.2.6 EUT OPERATING CONDITIONS

Same as 4.1.6.



A D T

### 4.2.7 TEST RESULTS

BELOW 1GHz WORST-CASE DATA : 802.11n (20MHz)

<b>CHANNEL</b>	Channel 64	<b>PHASE</b>	Line 1
<b>TEST MODE</b>	A	<b>6dB BANDWIDTH</b>	9kHz

No	Freq. [MHz]	Corr. Factor (dB)	Reading Value		Emission Level		Limit		Margin	
			[dB (uV)]		[dB (uV)]		[dB (uV)]		(dB)	
			Q.P.	AV.	Q.P.	AV.	Q.P.	AV.	Q.P.	AV.
1	0.150	0.12	56.31	42.03	56.43	42.15	66.00	56.00	-9.57	-13.85
2	0.175	0.12	51.13	-	51.25	-	64.70	54.70	-13.45	-
3	0.525	0.22	48.67	38.31	48.89	38.53	56.00	46.00	-7.11	-7.47
4	4.359	0.38	45.68	33.94	46.06	34.32	56.00	46.00	-9.94	-11.68
5	4.822	0.40	46.76	35.92	47.16	36.32	56.00	46.00	-8.84	-9.68
6	10.658	0.70	55.00	46.02	55.70	46.72	60.00	50.00	-4.30	-3.28

- REMARKS:**
1. Q.P. and AV. are abbreviations of quasi-peak and average individually.
  2. "-": The Quasi-peak reading value also meets average limit and measurement with the average detector is unnecessary.
  3. The emission levels of other frequencies were very low against the limit.
  4. Margin value = Emission level - Limit value
  5. Correction factor = Insertion loss + Cable loss
  6. Emission Level = Correction Factor + Reading Value.

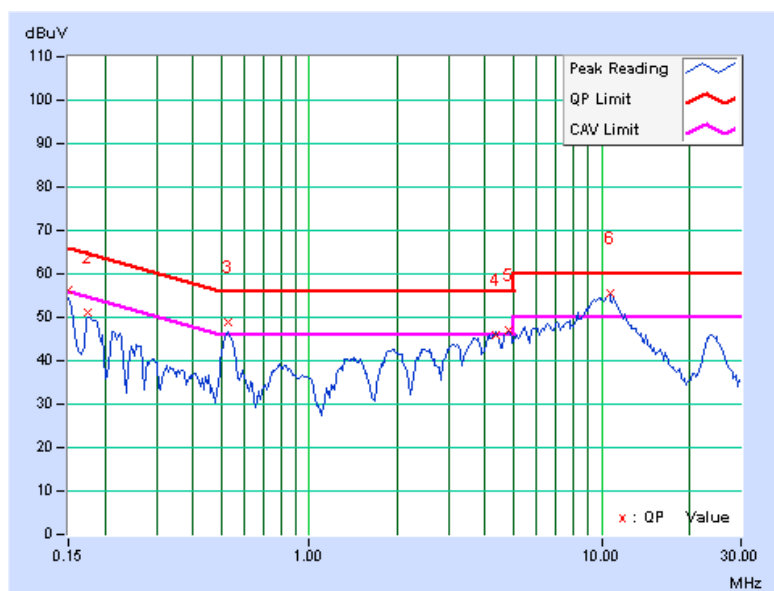



A D T

<b>CHANNEL</b>	Channel 64	<b>PHASE</b>	Line 2
<b>TEST MODE</b>	A	<b>6dB BANDWIDTH</b>	9kHz

No	Freq. [MHz]	Corr. Factor (dB)	Reading Value		Emission Level		Limit		Margin	
			[dB (uV)]		[dB (uV)]		[dB (uV)]		(dB)	
			Q.P.	AV.	Q.P.	AV.	Q.P.	AV.	Q.P.	AV.
1	0.150	0.09	57.84	44.03	57.93	44.12	66.00	56.00	-8.07	-11.88
2	0.181	0.09	54.05	-	54.14	-	64.43	54.43	-10.29	-
3	0.220	0.10	50.98	-	51.08	-	62.81	52.81	-11.73	-
4	0.532	0.20	52.01	38.32	52.21	38.52	56.00	46.00	-3.79	-7.48
5	0.790	0.21	41.74	-	41.95	-	56.00	46.00	-14.05	-
6	10.238	0.53	48.73	-	49.26	-	60.00	50.00	-10.74	-

- REMARKS:**
1. Q.P. and AV. are abbreviations of quasi-peak and average individually.
  2. "-": The Quasi-peak reading value also meets average limit and measurement with the average detector is unnecessary.
  3. The emission levels of other frequencies were very low against the limit.
  4. Margin value = Emission level - Limit value
  5. Correction factor = Insertion loss + Cable loss
  6. Emission Level = Correction Factor + Reading Value.

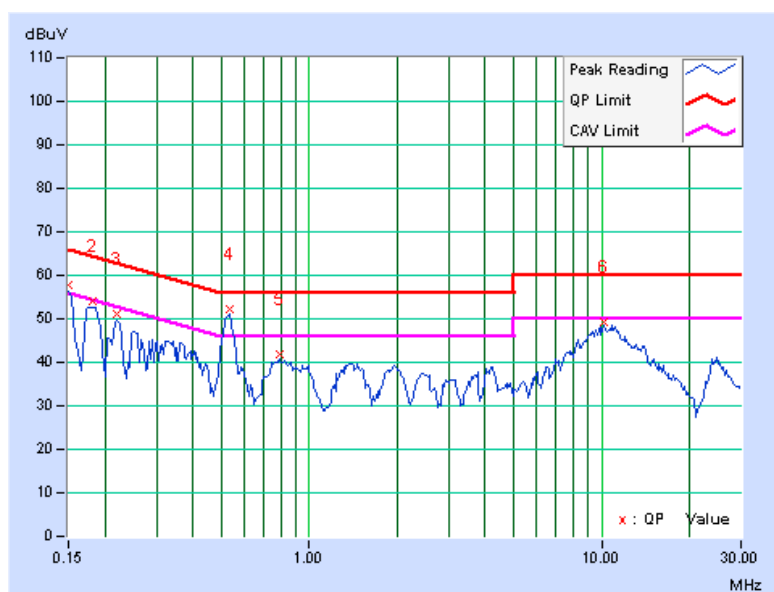



A D T

<b>CHANNEL</b>	Channel 64	<b>PHASE</b>	Line 1
<b>TEST MODE</b>	B	<b>6dB BANDWIDTH</b>	9kHz

No	Freq. [MHz]	Corr. Factor (dB)	Reading Value		Emission Level		Limit		Margin	
			[dB (uV)]		[dB (uV)]		[dB (uV)]		(dB)	
			Q.P.	AV.	Q.P.	AV.	Q.P.	AV.	Q.P.	AV.
1	0.150	0.12	48.10	-	48.22	-	66.00	56.00	-17.78	-
2	0.236	0.14	44.41	-	44.55	-	62.24	52.24	-17.69	-
3	0.312	0.18	41.34	-	41.52	-	59.93	49.93	-18.41	-
4	0.552	0.23	39.10	-	39.33	-	56.00	46.00	-16.67	-
5	25.335	1.52	28.98	-	30.50	-	60.00	50.00	-29.50	-
6	29.289	1.60	34.36	-	35.96	-	60.00	50.00	-24.04	-

- REMARKS:**
1. Q.P. and AV. are abbreviations of quasi-peak and average individually.
  2. "-": The Quasi-peak reading value also meets average limit and measurement with the average detector is unnecessary.
  3. The emission levels of other frequencies were very low against the limit.
  4. Margin value = Emission level - Limit value
  5. Correction factor = Insertion loss + Cable loss
  6. Emission Level = Correction Factor + Reading Value.

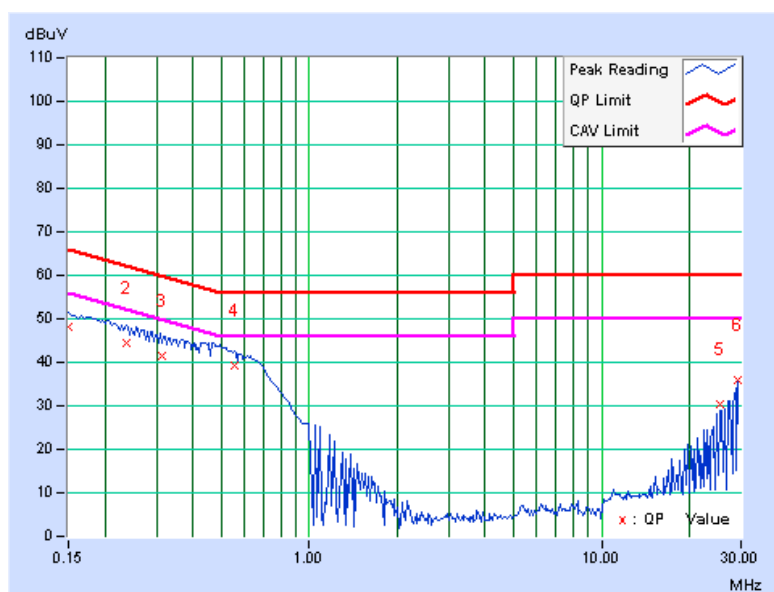



A D T

<b>CHANNEL</b>	Channel 64	<b>PHASE</b>	Line 2
<b>TEST MODE</b>	B	<b>6dB BANDWIDTH</b>	9kHz

No	Freq. [MHz]	Corr. Factor (dB)	Reading Value		Emission Level		Limit		Margin	
			[dB (uV)]		[dB (uV)]		[dB (uV)]		(dB)	
			Q.P.	AV.	Q.P.	AV.	Q.P.	AV.	Q.P.	AV.
1	0.159	0.09	47.72	-	47.81	-	65.51	55.51	-17.70	-
2	0.213	0.10	46.46	-	46.56	-	63.10	53.10	-16.55	-
3	0.378	0.19	42.20	-	42.39	-	58.33	48.33	-15.94	-
4	0.501	0.20	41.85	-	42.05	-	56.00	46.00	-13.95	-
5	0.568	0.21	40.54	-	40.75	-	56.00	46.00	-15.25	-
6	29.267	1.20	31.55	-	32.75	-	60.00	50.00	-27.25	-

- REMARKS:**
1. Q.P. and AV. are abbreviations of quasi-peak and average individually.
  2. "-": The Quasi-peak reading value also meets average limit and measurement with the average detector is unnecessary.
  3. The emission levels of other frequencies were very low against the limit.
  4. Margin value = Emission level - Limit value
  5. Correction factor = Insertion loss + Cable loss
  6. Emission Level = Correction Factor + Reading Value.

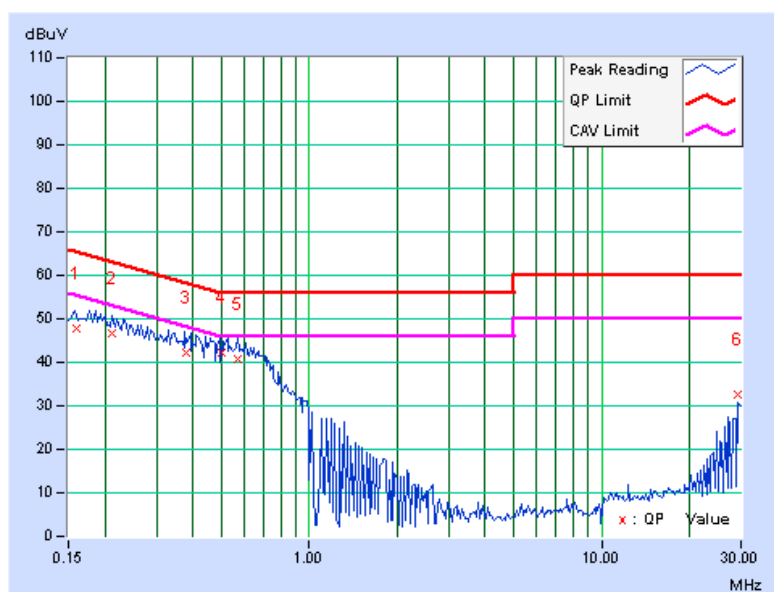



A D T

<b>CHANNEL</b>	Channel 64	<b>PHASE</b>	Line 1
<b>TEST MODE</b>	C	<b>6dB BANDWIDTH</b>	9kHz

No	Freq. [MHz]	Corr. Factor (dB)	Reading Value		Emission Level		Limit		Margin	
			[dB (uV)]		[dB (uV)]		[dB (uV)]		(dB)	
			Q.P.	AV.	Q.P.	AV.	Q.P.	AV.	Q.P.	AV.
1	0.150	0.12	57.78	43.20	57.90	43.32	66.00	56.00	-8.10	-12.68
2	0.175	0.12	52.51	-	52.63	-	64.73	54.73	-12.10	-
3	0.526	0.22	48.17	38.06	48.39	38.28	56.00	46.00	-7.61	-7.72
4	4.567	0.39	42.03	-	42.42	-	56.00	46.00	-13.58	-
<b>5</b>	<b>10.477</b>	<b>0.69</b>	<b>55.00</b>	<b>46.15</b>	<b>55.69</b>	<b>46.84</b>	<b>60.00</b>	<b>50.00</b>	<b>-4.31</b>	<b>-3.16</b>
6	24.024	1.49	45.57	-	47.06	-	60.00	50.00	-12.94	-

- REMARKS:**
1. Q.P. and AV. are abbreviations of quasi-peak and average individually.
  2. "-": The Quasi-peak reading value also meets average limit and measurement with the average detector is unnecessary.
  3. The emission levels of other frequencies were very low against the limit.
  4. Margin value = Emission level - Limit value
  5. Correction factor = Insertion loss + Cable loss
  6. Emission Level = Correction Factor + Reading Value.

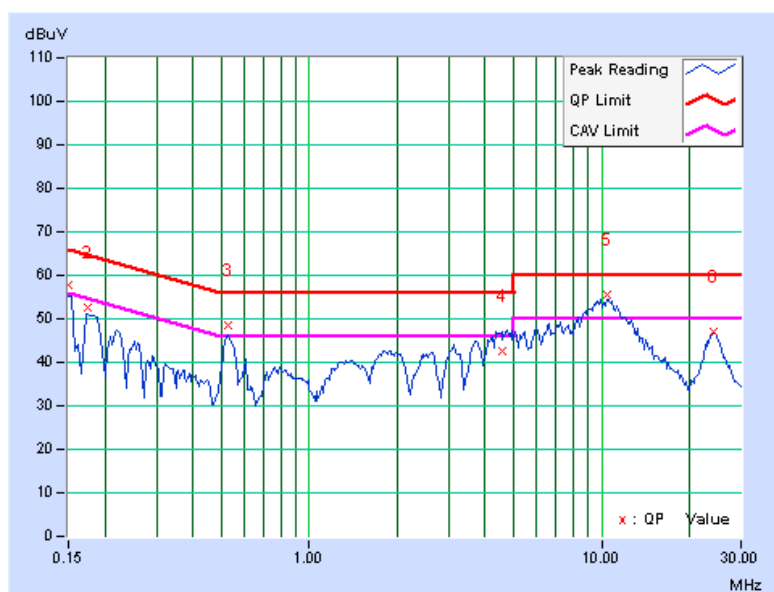





A D T

<b>CHANNEL</b>	Channel 64	<b>PHASE</b>	Line 2
<b>TEST MODE</b>	C	<b>6dB BANDWIDTH</b>	9kHz

No	Freq. [MHz]	Corr. Factor (dB)	Reading Value		Emission Level		Limit		Margin	
			[dB (uV)]		[dB (uV)]		[dB (uV)]		(dB)	
			Q.P.	AV.	Q.P.	AV.	Q.P.	AV.	Q.P.	AV.
1	0.150	0.09	59.02	44.73	59.11	44.82	66.00	56.00	-6.89	-11.18
2	0.182	0.09	55.02	40.64	55.11	40.73	64.39	54.39	-9.28	-13.66
3	0.189	0.09	54.68	39.70	54.77	39.79	64.08	54.08	-9.31	-14.29
4	0.213	0.10	51.29	-	51.39	-	63.11	53.11	-11.72	-
5	0.529	0.20	52.29	41.22	52.49	41.42	56.00	46.00	-3.51	-4.58
6	10.789	0.56	48.95	-	49.51	-	60.00	50.00	-10.49	-

- REMARKS:**
1. Q.P. and AV. are abbreviations of quasi-peak and average individually.
  2. "-": The Quasi-peak reading value also meets average limit and measurement with the average detector is unnecessary.
  3. The emission levels of other frequencies were very low against the limit.
  4. Margin value = Emission level - Limit value
  5. Correction factor = Insertion loss + Cable loss
  6. Emission Level = Correction Factor + Reading Value.

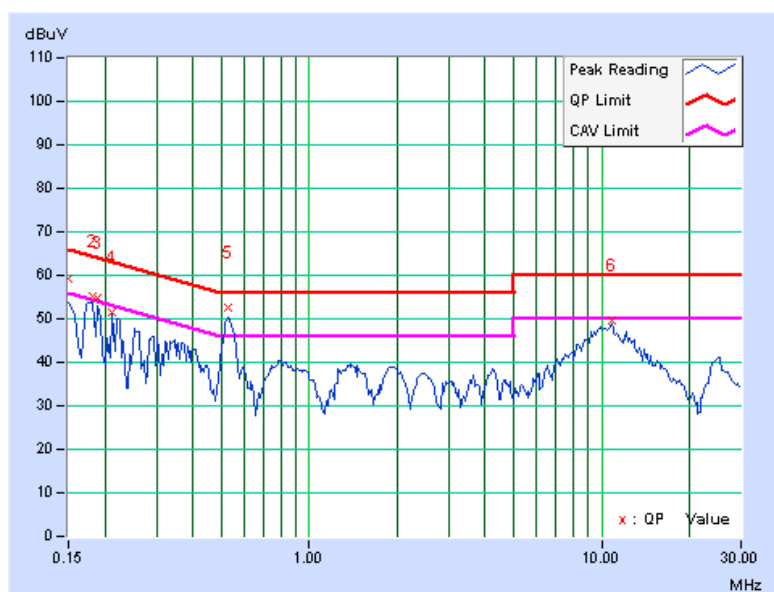



A D T

<b>CHANNEL</b>	Channel 64	<b>PHASE</b>	Line 1
<b>TEST MODE</b>	D	<b>6dB BANDWIDTH</b>	9kHz

No	Freq. [MHz]	Corr. Factor (dB)	Reading Value		Emission Level		Limit		Margin	
			[dB (uV)]		[dB (uV)]		[dB (uV)]		(dB)	
			Q.P.	AV.	Q.P.	AV.	Q.P.	AV.	Q.P.	AV.
1	0.150	0.12	47.89	-	48.01	-	66.00	56.00	-17.99	-
2	0.197	0.12	46.68	-	46.80	-	63.74	53.74	-16.94	-
3	0.291	0.17	43.05	-	43.22	-	60.51	50.51	-17.29	-
4	0.437	0.22	41.66	-	41.88	-	57.11	47.11	-15.23	-
5	0.600	0.23	39.78	-	40.01	-	56.00	46.00	-15.99	-
6	29.254	1.60	33.69	-	35.29	-	60.00	50.00	-24.71	-

- REMARKS:**
1. Q.P. and AV. are abbreviations of quasi-peak and average individually.
  2. "-": The Quasi-peak reading value also meets average limit and measurement with the average detector is unnecessary.
  3. The emission levels of other frequencies were very low against the limit.
  4. Margin value = Emission level - Limit value
  5. Correction factor = Insertion loss + Cable loss
  6. Emission Level = Correction Factor + Reading Value.

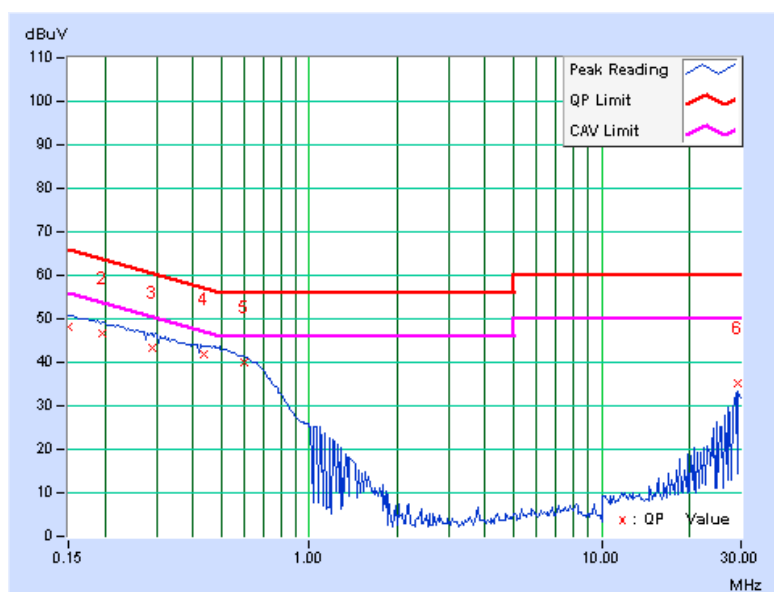



A D T

<b>CHANNEL</b>	Channel 64	<b>PHASE</b>	Line 2
<b>TEST MODE</b>	D	<b>6dB BANDWIDTH</b>	9kHz

No	Freq. [MHz]	Corr. Factor (dB)	Reading Value		Emission Level		Limit		Margin	
			[dB (uV)]		[dB (uV)]		[dB (uV)]		(dB)	
			Q.P.	AV.	Q.P.	AV.	Q.P.	AV.	Q.P.	AV.
1	0.170	0.09	47.91	-	48.00	-	64.98	54.98	-16.98	-
2	0.189	0.09	47.21	-	47.30	-	64.07	54.07	-16.77	-
3	0.343	0.17	41.10	-	41.27	-	59.14	49.14	-17.87	-
4	0.447	0.20	40.41	-	40.61	-	56.93	46.93	-16.32	-
5	0.498	0.20	41.12	-	41.32	-	56.04	46.04	-14.71	-
6	0.578	0.21	39.96	-	40.17	-	56.00	46.00	-15.83	-

- REMARKS:**
1. Q.P. and AV. are abbreviations of quasi-peak and average individually.
  2. "-": The Quasi-peak reading value also meets average limit and measurement with the average detector is unnecessary.
  3. The emission levels of other frequencies were very low against the limit.
  4. Margin value = Emission level - Limit value
  5. Correction factor = Insertion loss + Cable loss
  6. Emission Level = Correction Factor + Reading Value.

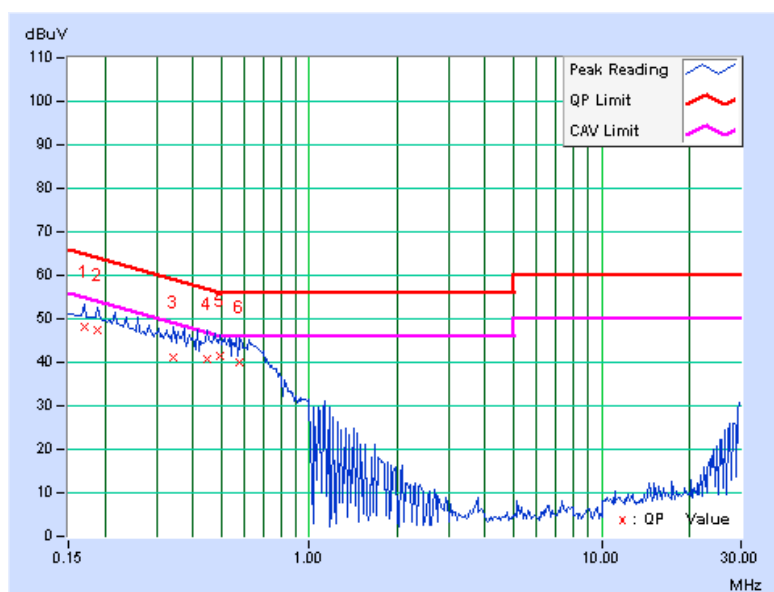



A D T

<b>CHANNEL</b>	Channel 100	<b>PHASE</b>	Line 1
<b>TEST MODE</b>	A	<b>6dB BANDWIDTH</b>	9kHz

No	Freq. [MHz]	Corr. Factor (dB)	Reading Value		Emission Level		Limit		Margin	
			[dB (uV)]		[dB (uV)]		[dB (uV)]		(dB)	
			Q.P.	AV.	Q.P.	AV.	Q.P.	AV.	Q.P.	AV.
1	0.150	0.12	55.90	41.19	56.02	41.31	66.00	56.00	-9.98	-14.69
2	0.177	0.12	51.10	-	51.22	-	64.61	54.61	-13.39	-
3	0.525	0.22	48.65	37.86	48.87	38.08	56.00	46.00	-7.13	-7.92
4	4.308	0.37	46.85	35.97	47.22	36.34	56.00	46.00	-8.78	-9.66
5	4.770	0.40	45.49	-	45.89	-	56.00	46.00	-10.11	-
6	9.844	0.64	53.72	44.59	54.36	45.23	60.00	50.00	-5.64	-4.77

- REMARKS:**
1. Q.P. and AV. are abbreviations of quasi-peak and average individually.
  2. "-": The Quasi-peak reading value also meets average limit and measurement with the average detector is unnecessary.
  3. The emission levels of other frequencies were very low against the limit.
  4. Margin value = Emission level - Limit value
  5. Correction factor = Insertion loss + Cable loss
  6. Emission Level = Correction Factor + Reading Value.

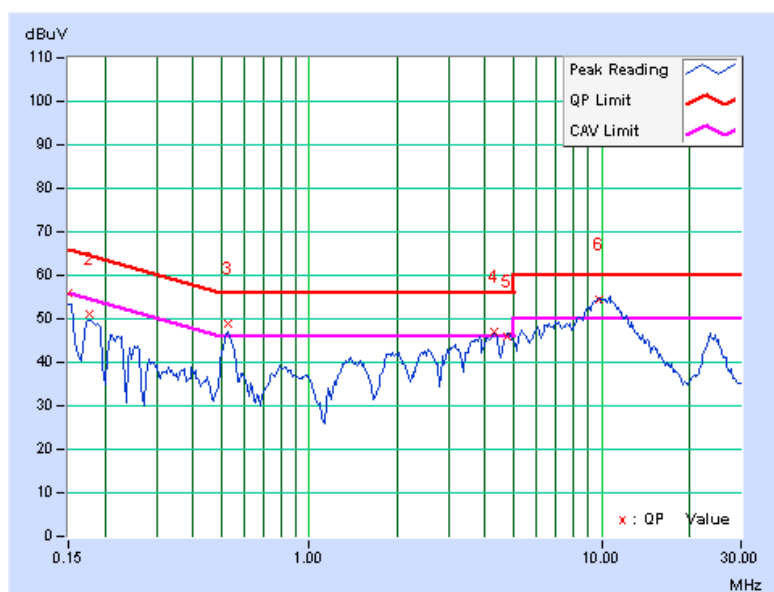



A D T

<b>CHANNEL</b>	Channel 100	<b>PHASE</b>	Line 2
<b>TEST MODE</b>	A	<b>6dB BANDWIDTH</b>	9kHz

No	Freq. [MHz]	Corr. Factor (dB)	Reading Value		Emission Level		Limit		Margin	
			[dB (uV)]		[dB (uV)]		[dB (uV)]		(dB)	
			Q.P.	AV.	Q.P.	AV.	Q.P.	AV.	Q.P.	AV.
1	0.150	0.09	57.39	43.32	57.48	43.41	66.00	56.00	-8.52	-12.59
2	0.182	0.09	53.91	-	54.00	-	64.42	54.42	-10.42	-
3	0.217	0.10	50.10	-	50.20	-	62.95	52.95	-12.75	-
4	0.529	0.20	52.26	39.70	52.46	39.90	56.00	46.00	-3.54	-6.10
5	0.826	0.21	41.91	-	42.12	-	56.00	46.00	-13.88	-
6	10.641	0.55	49.13	-	49.68	-	60.00	50.00	-10.32	-

- REMARKS:**
1. Q.P. and AV. are abbreviations of quasi-peak and average individually.
  2. "-": The Quasi-peak reading value also meets average limit and measurement with the average detector is unnecessary.
  3. The emission levels of other frequencies were very low against the limit.
  4. Margin value = Emission level - Limit value
  5. Correction factor = Insertion loss + Cable loss
  6. Emission Level = Correction Factor + Reading Value.

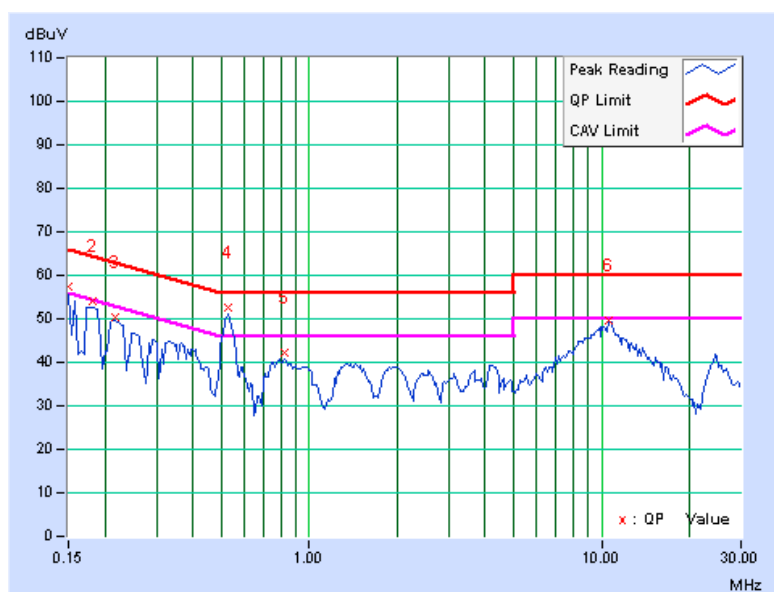



A D T

<b>CHANNEL</b>	Channel 100	<b>PHASE</b>	Line 1
<b>TEST MODE</b>	B	<b>6dB BANDWIDTH</b>	9kHz

No	Freq. [MHz]	Corr. Factor (dB)	Reading Value		Emission Level		Limit		Margin	
			[dB (uV)]		[dB (uV)]		[dB (uV)]		(dB)	
			Q.P.	AV.	Q.P.	AV.	Q.P.	AV.	Q.P.	AV.
1	0.170	0.12	46.55	-	46.67	-	64.98	54.98	-18.31	-
2	0.236	0.14	44.24	-	44.38	-	62.24	52.24	-17.86	-
3	0.281	0.16	42.31	-	42.47	-	60.77	50.77	-18.30	-
4	0.373	0.21	40.78	-	40.99	-	58.44	48.44	-17.45	-
5	0.444	0.22	40.39	-	40.61	-	56.98	46.98	-16.37	-
6	28.704	1.58	33.15	-	34.73	-	60.00	50.00	-25.27	-

- REMARKS:**
1. Q.P. and AV. are abbreviations of quasi-peak and average individually.
  2. "-": The Quasi-peak reading value also meets average limit and measurement with the average detector is unnecessary.
  3. The emission levels of other frequencies were very low against the limit.
  4. Margin value = Emission level - Limit value
  5. Correction factor = Insertion loss + Cable loss
  6. Emission Level = Correction Factor + Reading Value.

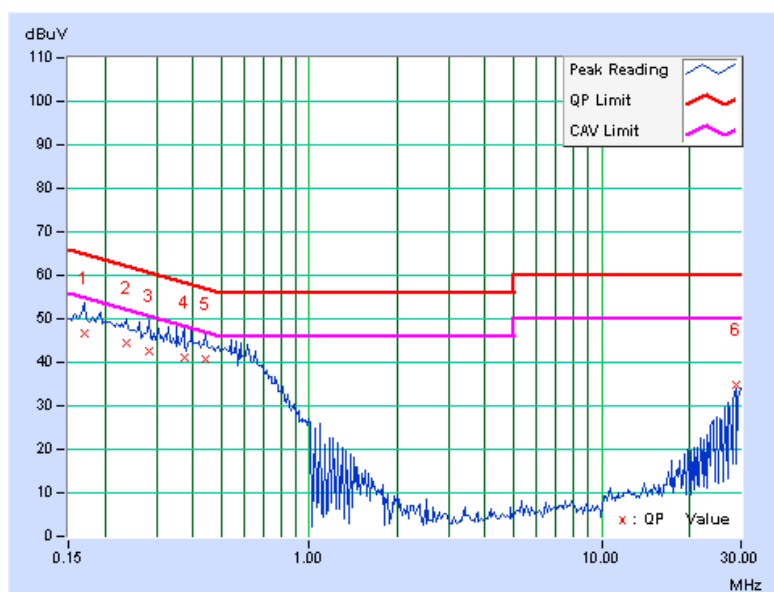



A D T

<b>CHANNEL</b>	Channel 100	<b>PHASE</b>	Line 2
<b>TEST MODE</b>	B	<b>6dB BANDWIDTH</b>	9kHz

No	Freq. [MHz]	Corr. Factor (dB)	Reading Value		Emission Level		Limit		Margin	
			[dB (uV)]		[dB (uV)]		[dB (uV)]		(dB)	
			Q.P.	AV.	Q.P.	AV.	Q.P.	AV.	Q.P.	AV.
1	0.150	0.09	47.72	-	47.81	-	66.00	56.00	-18.19	-
2	0.162	0.09	47.68	-	47.77	-	65.37	55.37	-17.60	-
3	0.192	0.09	46.84	-	46.93	-	63.96	53.96	-17.03	-
4	0.405	0.20	41.77	-	41.97	-	57.74	47.74	-15.77	-
5	0.555	0.21	40.05	-	40.26	-	56.00	46.00	-15.74	-
6	29.836	1.21	30.86	-	32.07	-	60.00	50.00	-27.93	-

- REMARKS:**
1. Q.P. and AV. are abbreviations of quasi-peak and average individually.
  2. "-": The Quasi-peak reading value also meets average limit and measurement with the average detector is unnecessary.
  3. The emission levels of other frequencies were very low against the limit.
  4. Margin value = Emission level - Limit value
  5. Correction factor = Insertion loss + Cable loss
  6. Emission Level = Correction Factor + Reading Value.

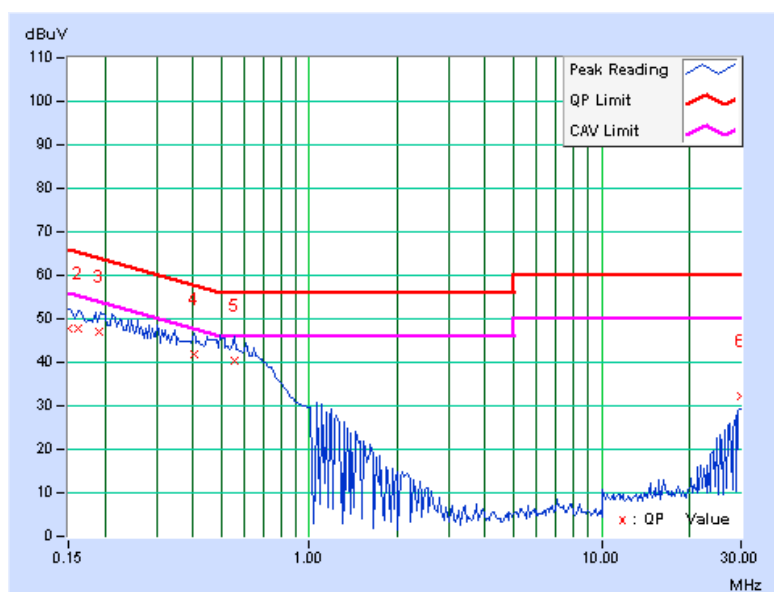



A D T

<b>CHANNEL</b>	Channel 100	<b>PHASE</b>	Line 1
<b>TEST MODE</b>	C	<b>6dB BANDWIDTH</b>	9kHz

No	Freq. [MHz]	Corr. Factor (dB)	Reading Value		Emission Level		Limit		Margin	
			[dB (uV)]		[dB (uV)]		[dB (uV)]		(dB)	
			Q.P.	AV.	Q.P.	AV.	Q.P.	AV.	Q.P.	AV.
1	0.150	0.12	57.29	43.06	57.41	43.18	66.00	56.00	-8.59	-12.82
2	0.533	0.22	47.67	34.27	47.89	34.49	56.00	46.00	-8.11	-11.51
3	3.625	0.35	45.69	34.70	46.04	35.05	56.00	46.00	-9.96	-10.95
4	4.180	0.37	46.56	35.85	46.93	36.22	56.00	46.00	-9.07	-9.78
5	4.805	0.40	46.84	35.97	47.24	36.37	56.00	46.00	-8.76	-9.63
6	9.856	0.64	54.24	45.17	54.88	45.81	60.00	50.00	-5.12	-4.19

- REMARKS:**
1. Q.P. and AV. are abbreviations of quasi-peak and average individually.
  2. "-": The Quasi-peak reading value also meets average limit and measurement with the average detector is unnecessary.
  3. The emission levels of other frequencies were very low against the limit.
  4. Margin value = Emission level - Limit value
  5. Correction factor = Insertion loss + Cable loss
  6. Emission Level = Correction Factor + Reading Value.

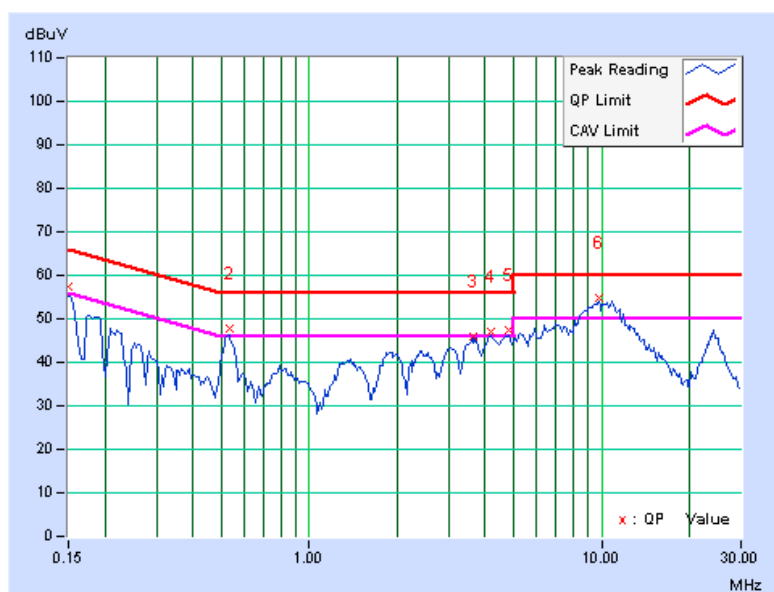





A D T

<b>CHANNEL</b>	Channel 100	<b>PHASE</b>	Line 2
<b>TEST MODE</b>	C	<b>6dB BANDWIDTH</b>	9kHz

No	Freq. [MHz]	Corr. Factor (dB)	Reading Value		Emission Level		Limit		Margin	
			[dB (uV)]		[dB (uV)]		[dB (uV)]		(dB)	
			Q.P.	AV.	Q.P.	AV.	Q.P.	AV.	Q.P.	AV.
1	0.150	0.09	58.86	45.16	58.95	45.25	66.00	56.00	-7.05	-10.75
2	0.193	0.09	51.47	-	51.56	-	63.91	53.91	-12.35	-
3	0.218	0.10	50.90	-	51.00	-	62.89	52.89	-11.89	-
4	0.533	0.20	51.69	38.47	51.89	38.67	56.00	46.00	-4.11	-7.33
5	1.362	0.23	41.25	-	41.48	-	56.00	46.00	-14.52	-
6	10.746	0.56	48.73	-	49.29	-	60.00	50.00	-10.71	-

- REMARKS:**
1. Q.P. and AV. are abbreviations of quasi-peak and average individually.
  2. "-": The Quasi-peak reading value also meets average limit and measurement with the average detector is unnecessary.
  3. The emission levels of other frequencies were very low against the limit.
  4. Margin value = Emission level - Limit value
  5. Correction factor = Insertion loss + Cable loss
  6. Emission Level = Correction Factor + Reading Value.

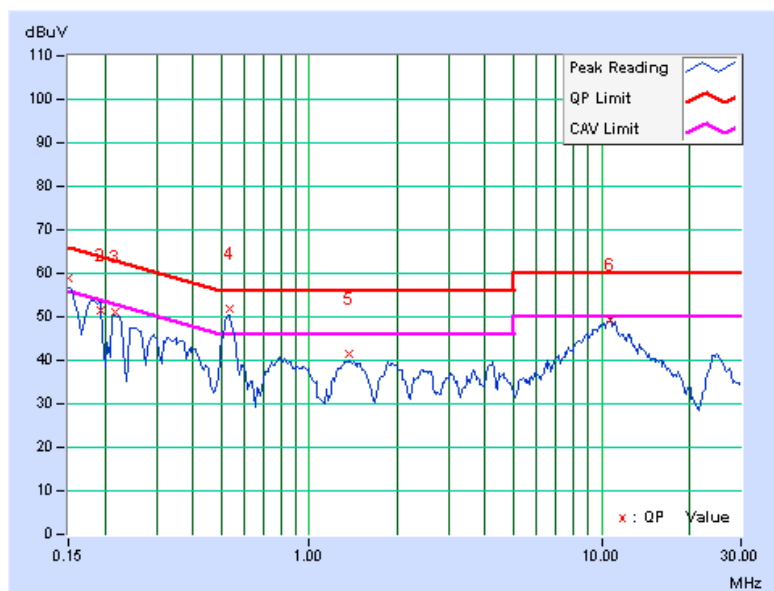



A D T

<b>CHANNEL</b>	Channel 100	<b>PHASE</b>	Line 1
<b>TEST MODE</b>	D	<b>6dB BANDWIDTH</b>	9kHz

No	Freq. [MHz]	Corr. Factor (dB)	Reading Value		Emission Level		Limit		Margin	
			[dB (uV)]		[dB (uV)]		[dB (uV)]		(dB)	
			Q.P.	AV.	Q.P.	AV.	Q.P.	AV.	Q.P.	AV.
1	0.170	0.12	47.10	-	47.22	-	64.98	54.98	-17.76	-
2	0.216	0.13	46.09	-	46.22	-	62.96	52.96	-16.74	-
3	0.419	0.22	40.24	-	40.46	-	57.46	47.46	-17.00	-
4	0.442	0.22	40.11	-	40.33	-	57.02	47.02	-16.68	-
5	0.463	0.22	39.80	-	40.02	-	56.65	46.65	-16.62	-
6	0.500	0.22	38.55	-	38.77	-	56.00	46.00	-17.23	-

- REMARKS:**
1. Q.P. and AV. are abbreviations of quasi-peak and average individually.
  2. "-": The Quasi-peak reading value also meets average limit and measurement with the average detector is unnecessary.
  3. The emission levels of other frequencies were very low against the limit.
  4. Margin value = Emission level - Limit value
  5. Correction factor = Insertion loss + Cable loss
  6. Emission Level = Correction Factor + Reading Value.

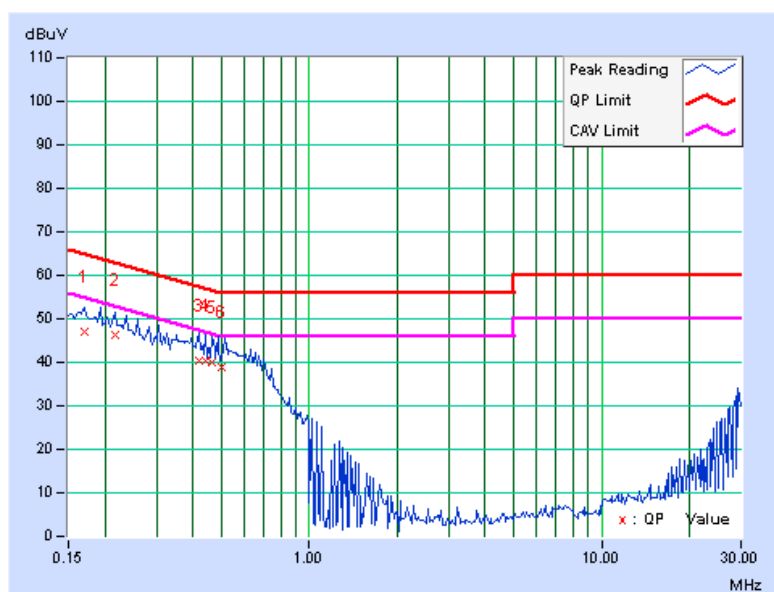



A D T

<b>CHANNEL</b>	Channel 100	<b>PHASE</b>	Line 2
<b>TEST MODE</b>	D	<b>6dB BANDWIDTH</b>	9kHz

No	Freq. [MHz]	Corr. Factor (dB)	Reading Value		Emission Level		Limit		Margin	
			[dB (uV)]		[dB (uV)]		[dB (uV)]		(dB)	
			Q.P.	AV.	Q.P.	AV.	Q.P.	AV.	Q.P.	AV.
1	0.155	0.09	46.86	-	46.95	-	65.72	55.72	-18.77	-
2	0.193	0.09	46.22	-	46.31	-	63.91	53.91	-17.60	-
3	0.296	0.14	42.22	-	42.36	-	60.36	50.36	-18.00	-
4	0.500	0.20	38.81	-	39.01	-	56.00	46.00	-16.99	-
5	0.525	0.20	39.56	-	39.76	-	56.00	46.00	-16.24	-
6	0.603	0.21	38.62	-	38.83	-	56.00	46.00	-17.17	-

- REMARKS:**
1. Q.P. and AV. are abbreviations of quasi-peak and average individually.
  2. "-": The Quasi-peak reading value also meets average limit and measurement with the average detector is unnecessary.
  3. The emission levels of other frequencies were very low against the limit.
  4. Margin value = Emission level - Limit value
  5. Correction factor = Insertion loss + Cable loss
  6. Emission Level = Correction Factor + Reading Value.

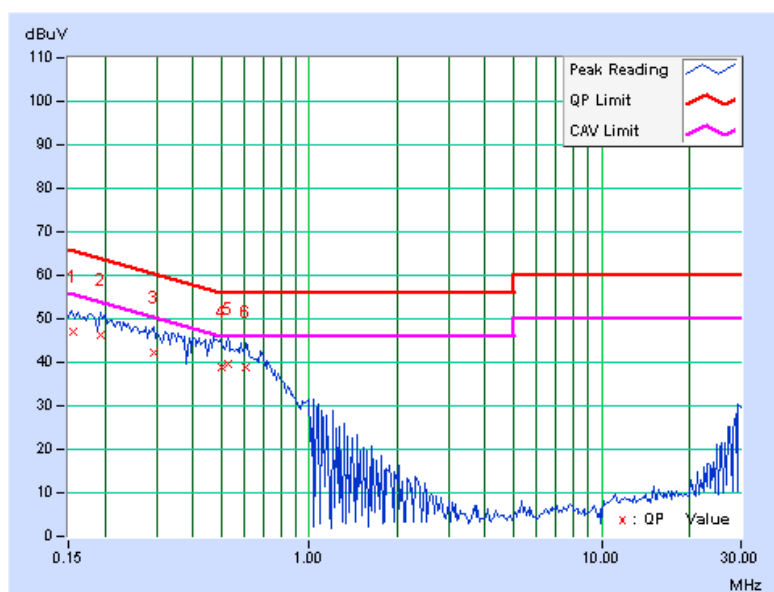



### 4.3 MAXIMUM CONDUCTED OUTPUT POWER MEASUREMENT

#### 4.3.1 LIMITS OF MAXIMUM CONDUCTED OUTPUT POWER MEASUREMENT

FREQUENCY BAND	LIMIT
5.150 ~ 5.250GHz	The lesser of 50mW (17dBm) or 4dBm + 10logB
5.250 ~ 5.350GHz	The lesser of 250mW (24dBm) or 11dBm + 10logB
5.470 ~ 5.725GHz	The lesser of 250mW (24dBm) or 11dBm + 10logB

**NOTE:** Where B is the 26dB emission bandwidth in MHz.

#### 4.3.2 TEST INSTRUMENTS

DESCRIPTION & MANUFACTURER	MODEL NO.	SERIAL NO.	DATE OF CALIBRATION	DUE DATE OF CALIBRATION
Agilent SPECTRUM ANALYZER	E4446A	MY46180403	June 22, 2009	June 21, 2010

**Note:** The calibration interval of the above test instruments is 12 months and the calibrations are traceable to NML/ROC and NIST/USA.

#### 4.3.3 TEST PROCEDURES

- a. The transmitter output was connected to the spectrum analyzer.
- b. Set span to encompass the entire emission bandwidth of the signal.
- c. Set RBW to 1MHz, VBW to 3MHz.
- d. Using the spectrum analyzer's channel power measurement function to measure the output power.

**NOTE:** The test is performed in accordance with FCC Public Notice: APPENDIX A Guidelines for Assessing Unlicensed National Information Infrastructure (U-NII) Devices – Part 15, Subpart E, August 2002.

The transmitter output operates continuously therefore Method # 1 is used.

#### 4.3.4 DEVIATION FROM TEST STANDARD

No deviation

#### 4.3.5 TEST SETUP

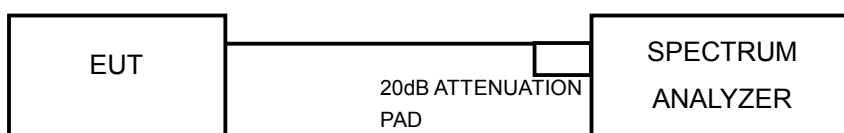

#### 4.3.6 EUT OPERATING CONDITIONS

The software provided by client to enable the EUT under transmission condition continuously at specific channel frequencies individually.



A D T

### 4.3.7 TEST RESULTS

#### POWER OUTPUT: 802.11a

For Mode A:

CHAN.	CHAN. FREQ. (MHz)	POWER OUTPUT (dBm)		TOTAL POWER (mW)	TOTAL POWER (dBm)	POWER LIMIT (dBm)	PASS / FAIL
		CHAIN 0	CHAIN 1				
52	5260	12.8	12.4	36.4	15.6	16	PASS
60	5300	12.9	12.8	<b>38.6</b>	15.9	16	PASS
64	5320	7.2	7.1	10.4	10.2	16	PASS
100	5500	10.1	10.0	20.2	13.1	16	PASS
120	5600	13.0	11.8	35.1	15.5	16	PASS
140	5700	10.7	10.2	22.2	13.5	16	PASS

**NOTE:** According to 15.407 (a) (1) (2), the maximum antenna gain 14dBi is higher than 6dBi, so the limit of output power shall be reduced by 8 dB.

#### CHAIN 0: CH 120

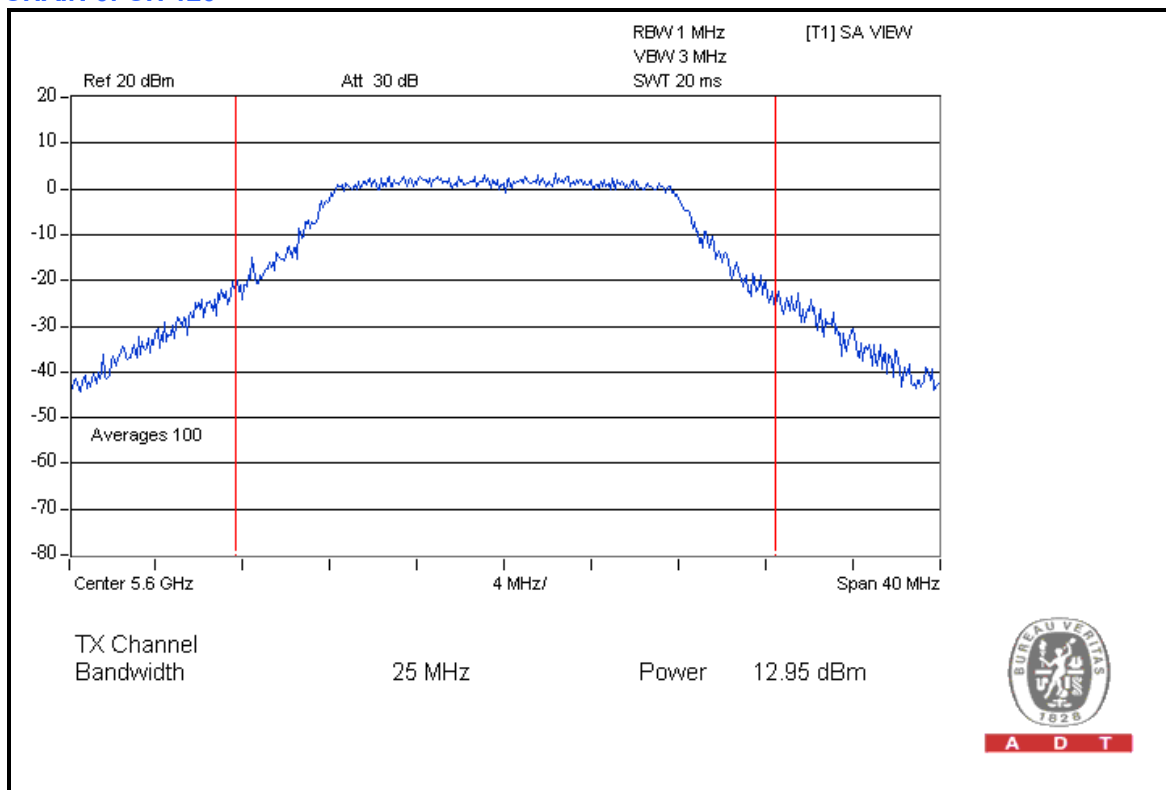

A D T



A D T

For Mode C:

CHAN.	CHAN. FREQ. (MHz)	POWER OUTPUT (dBm)		TOTAL POWER (mW)	TOTAL POWER (dBm)	POWER LIMIT (dBm)	PASS / FAIL
		CHAIN 0	CHAIN 1				
52	5260	1.9	0.8	2.8	4.4	7	PASS
60	5300	1.9	0.8	2.8	4.4	7	PASS
64	5320	-3.3	-3.4	0.9	-0.3	7	PASS
100	5500	1.9	0.9	2.8	4.4	7	PASS
120	5600	1.9	0.8	2.8	4.4	7	PASS
140	5700	1.9	1.2	2.9	4.6	7	PASS

**NOTE:** According to 15.407 (a) (1) (2), the maximum antenna gain 23dBi is higher than 6dBi, so the limit of output power shall be reduced by 17 dB.

CHAIN 0: CH 100

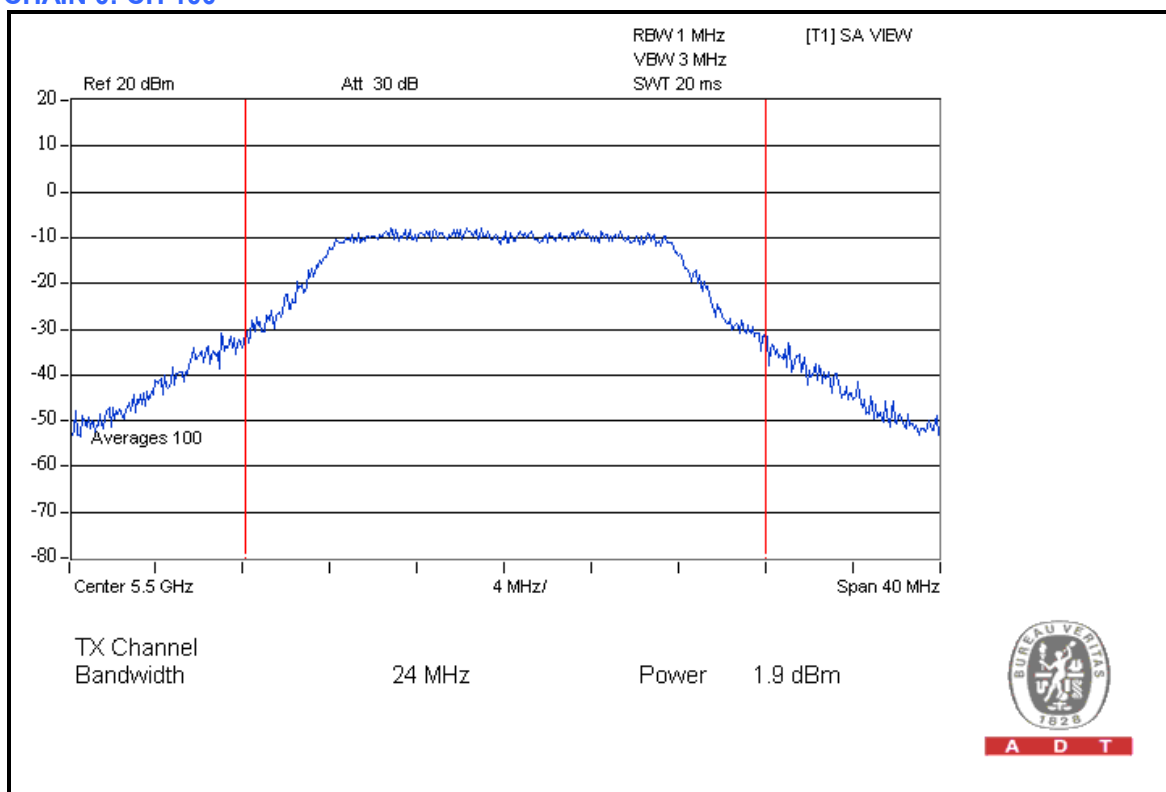

A D T



A D T

### 802.11n (20MHz)

For Mode A:

CHAN.	CHAN. FREQ. (MHz)	POWER OUTPUT (dBm)		TOTAL POWER (mW)	TOTAL POWER (dBm)	POWER LIMIT (dBm)	PASS / FAIL
		CHAIN 0	CHAIN 1				
52	5260	12.8	12.4	36.4	15.6	16	PASS
60	5300	12.9	12.8	<b>38.6</b>	15.9	16	PASS
64	5320	7.3	7.1	10.5	10.2	16	PASS
100	5500	10.2	10.2	20.9	13.2	16	PASS
120	5600	13.0	12.0	35.8	15.5	16	PASS
140	5700	10.9	10.3	23.0	13.6	16	PASS

**NOTE:** According to 15.407 (a) (1) (2), the maximum antenna gain 14dBi is higher than 6dBi, so the limit of output power shall be reduced by 8 dB.

### CHAIN 0: CH 120

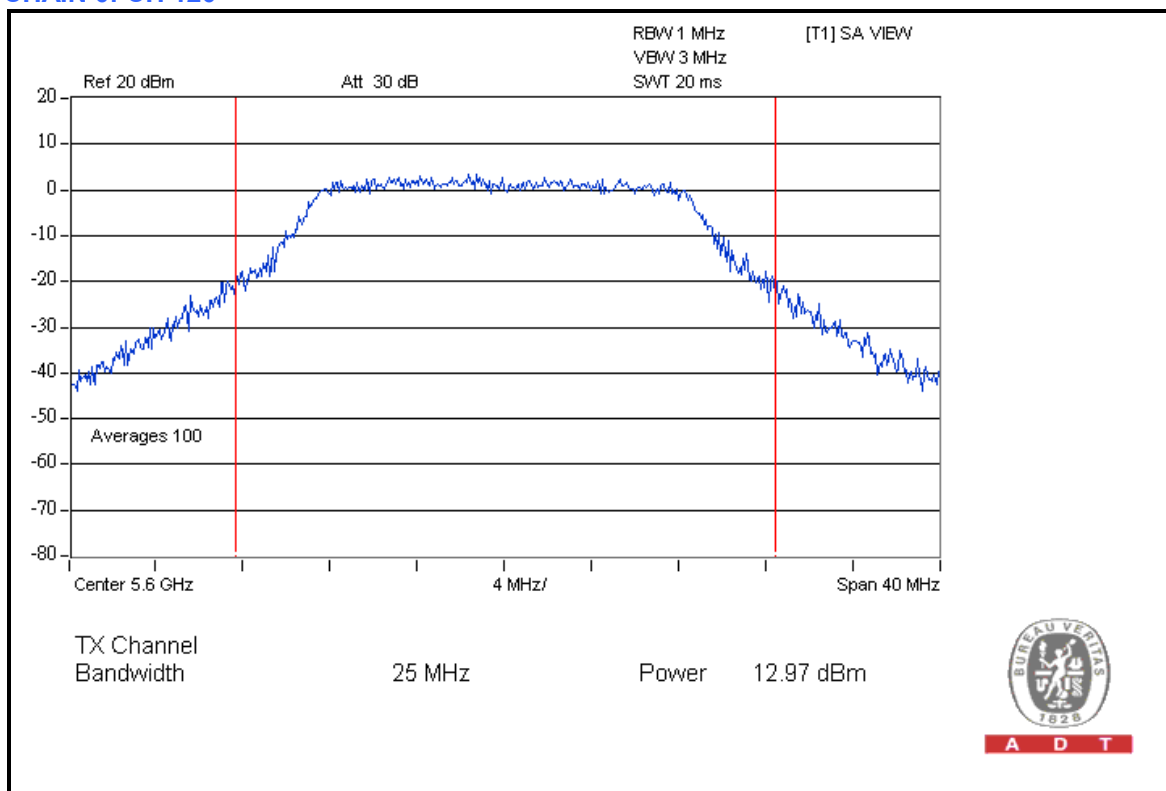

A D T





A D T

For Mode C:

CHAN.	CHAN. FREQ. (MHz)	POWER OUTPUT (dBm)		TOTAL POWER (mW)	TOTAL POWER (dBm)	POWER LIMIT (dBm)	PASS / FAIL
		CHAIN 0	CHAIN 1				
52	5260	2.0	0.8	2.8	4.5	7	PASS
60	5300	1.9	0.9	2.8	4.4	7	PASS
64	5320	-3.2	-3.3	0.9	-0.2	7	PASS
100	5500	2.0	1.0	2.8	4.5	7	PASS
120	5600	1.9	0.9	2.8	4.4	7	PASS
140	5700	1.9	1.1	2.8	4.5	7	PASS

NOTE: According to 15.407 (a) (1) (2), the maximum antenna gain 23dBi is higher than 6dBi, so the limit of output power shall be reduced by 17 dB.

CHAIN 0: CH 100

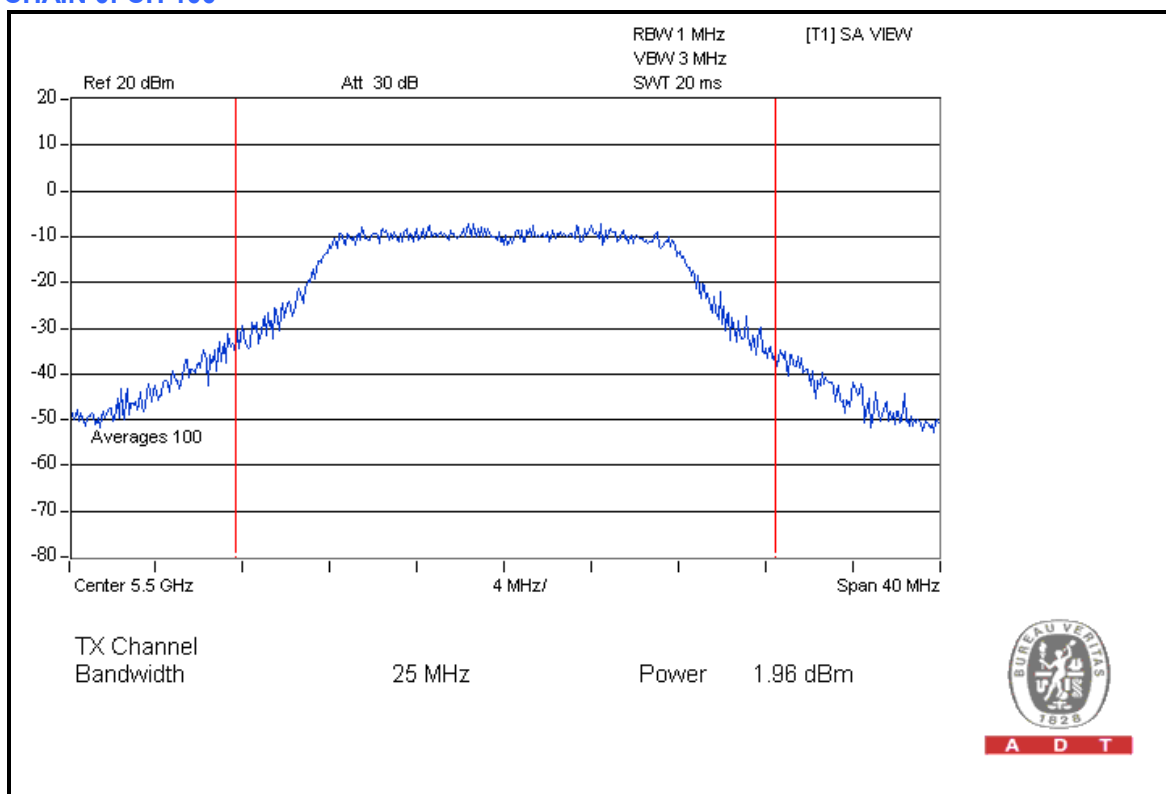

A D T



A D T

### 802.11n (40MHz)

For Mode A:

CHAN.	CHAN. FREQ. (MHz)	POWER OUTPUT (dBm)		TOTAL POWER (mW)	TOTAL POWER (dBm)	POWER LIMIT (dBm)	PASS / FAIL
		CHAIN 0	CHAIN 1				
54	5270	12.2	12.1	32.8	15.2	16	PASS
62	5310	6.1	6.1	8.1	9.1	16	PASS
102	5510	9.9	9.7	19.1	12.8	16	PASS
118	5590	11.3	10.3	24.2	13.8	16	PASS
134	5670	10.8	10.0	22.0	13.4	16	PASS

**NOTE:** According to 15.407 (a) (1) (2), the maximum antenna gain 14dBi is higher than 6dBi, so the limit of output power shall be reduced by 8 dB.

### CHAIN 0: CH 54

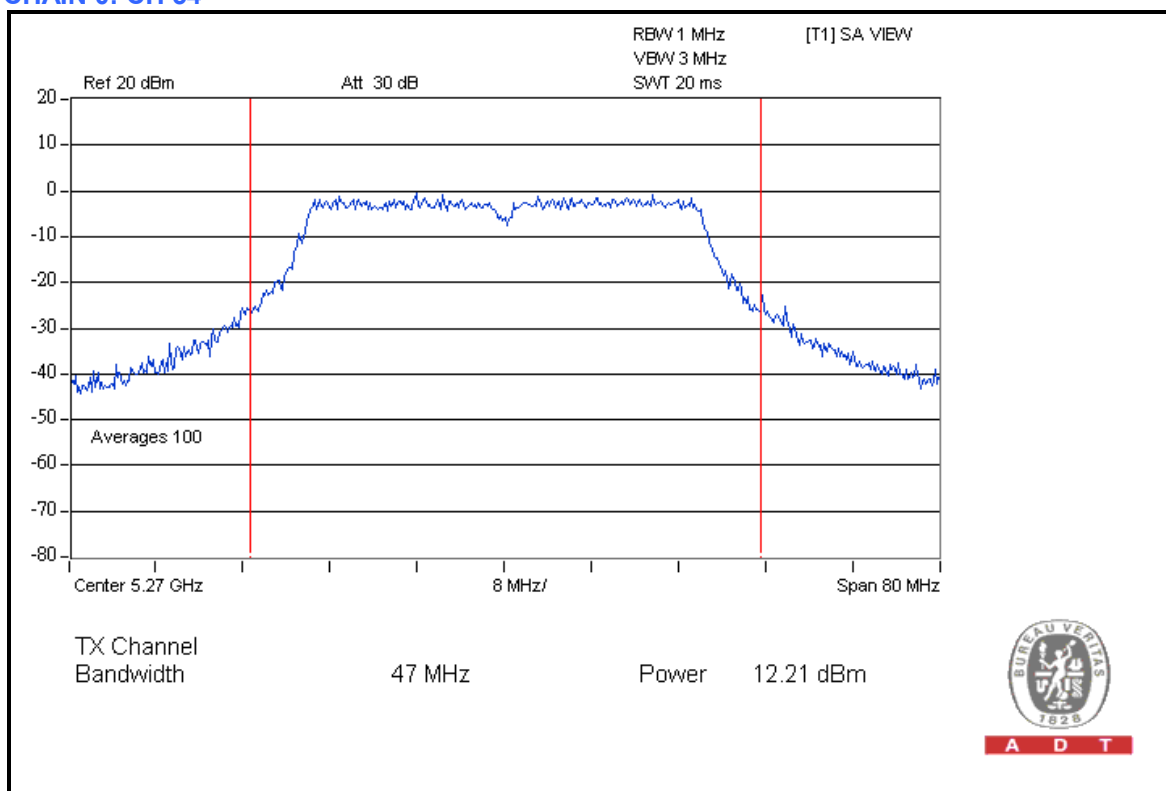

A D T



A D T

For Mode C:

CHAN.	CHAN. FREQ. (MHz)	POWER OUTPUT (dBm)		TOTAL POWER (mW)	TOTAL POWER (dBm)	POWER LIMIT (dBm)	PASS / FAIL
		CHAIN 0	CHAIN 1				
54	5270	1.8	1.1	2.8	4.5	7	PASS
62	5310	-3.1	-3.3	1.0	-0.2	7	PASS
102	5510	1.9	1.2	2.9	4.6	7	PASS
118	5590	1.9	0.8	2.8	4.4	7	PASS
134	5670	2.2	0.8	2.9	4.6	7	PASS

**NOTE:** According to 15.407 (a) (1) (2), the maximum antenna gain 23dBi is higher than 6dBi, so the limit of output power shall be reduced by 17 dB.

CHAIN 1: CH 134

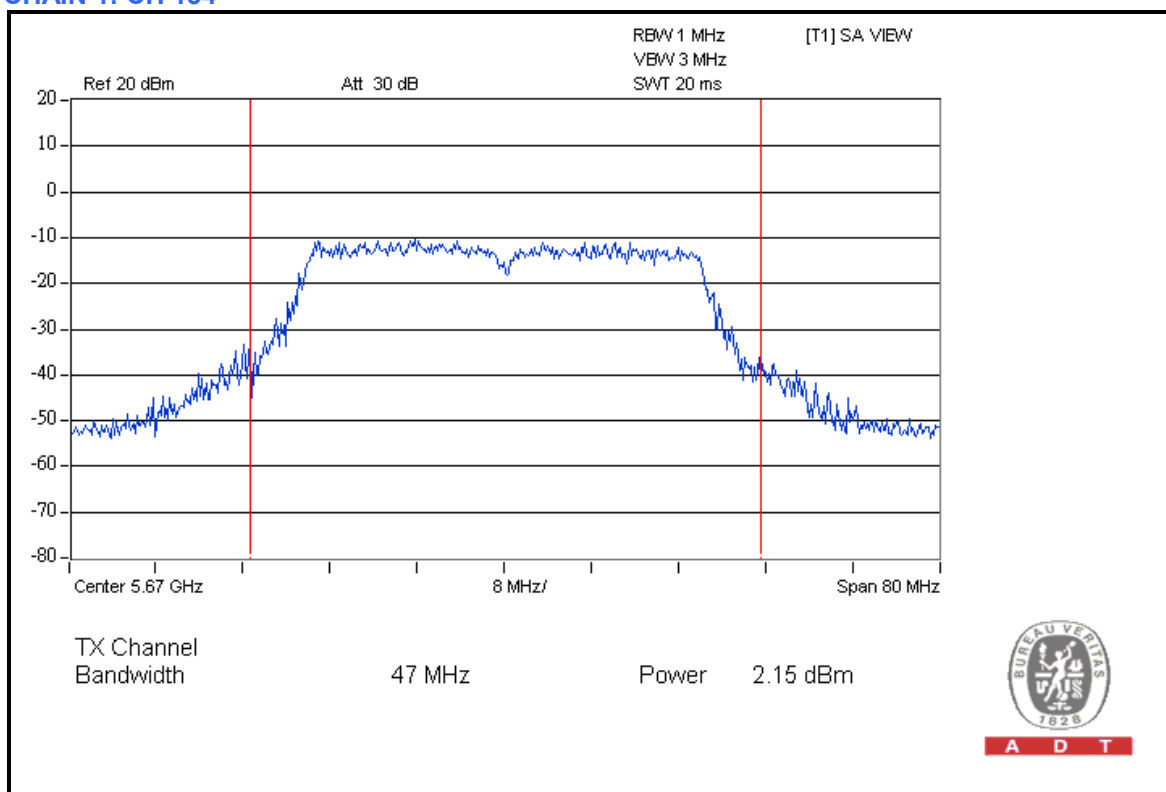



A D T

### 26dB OCCUPIED BANDWIDTH: 802.11a

For Mode A:

CHANNEL	CHANNEL FREQUENCY (MHz)	26dBc OCCUPIED BANDWIDTH (MHz)		PASS / FAIL
		CHAIN 0	CHAIN 1	
52	5260	23.9	23.9	PASS
60	5300	23.7	24.1	PASS
64	5320	23.6	24.0	PASS
100	5500	24.2	23.7	PASS
120	5600	24.1	24.0	PASS
140	5700	23.6	24.5	PASS

### CHAIN 1: CH 140

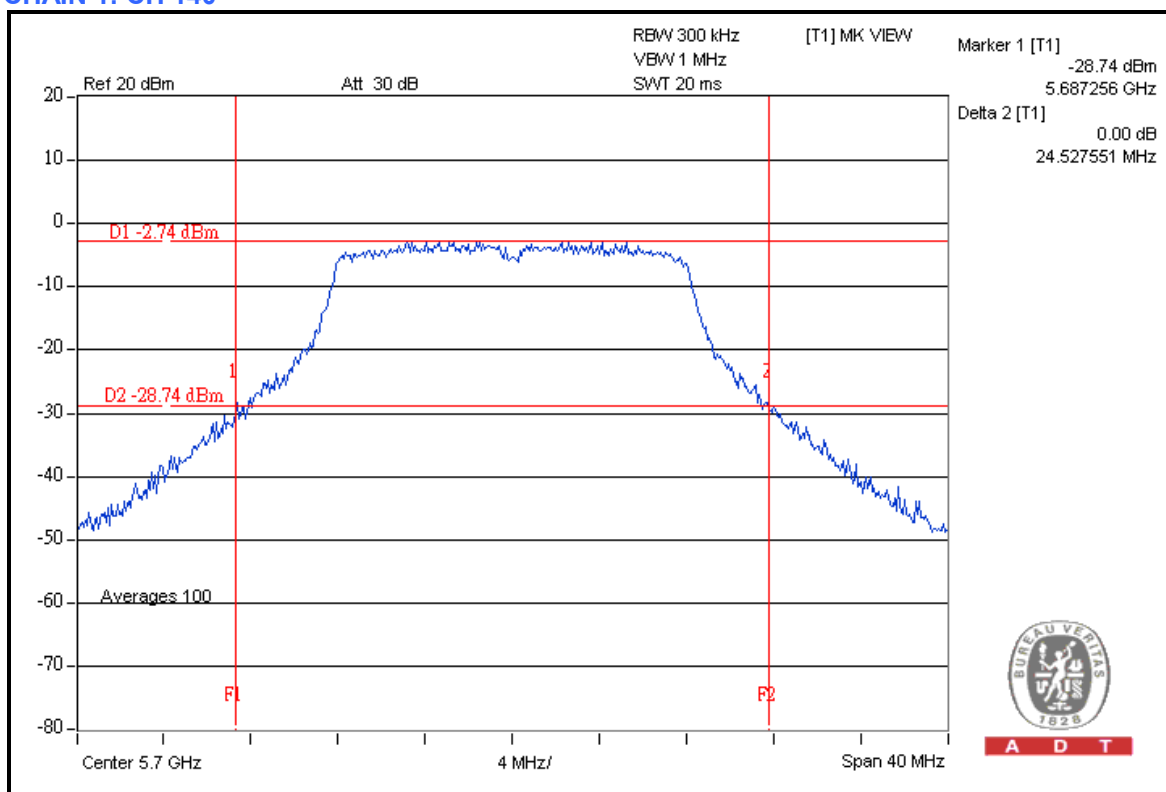



A D T

For Mode C:

CHANNEL	CHANNEL FREQUENCY (MHz)	26dBc OCCUPIED BANDWIDTH (MHz)		PASS / FAIL
		CHAIN 0	CHAIN 1	
52	5260	23.7	24.0	PASS
60	5300	23.8	24.3	PASS
64	5320	24.1	23.6	PASS
100	5500	23.9	24.7	PASS
120	5600	24.0	24.4	PASS
140	5700	24.1	23.7	PASS

CHAIN 1: CH 100

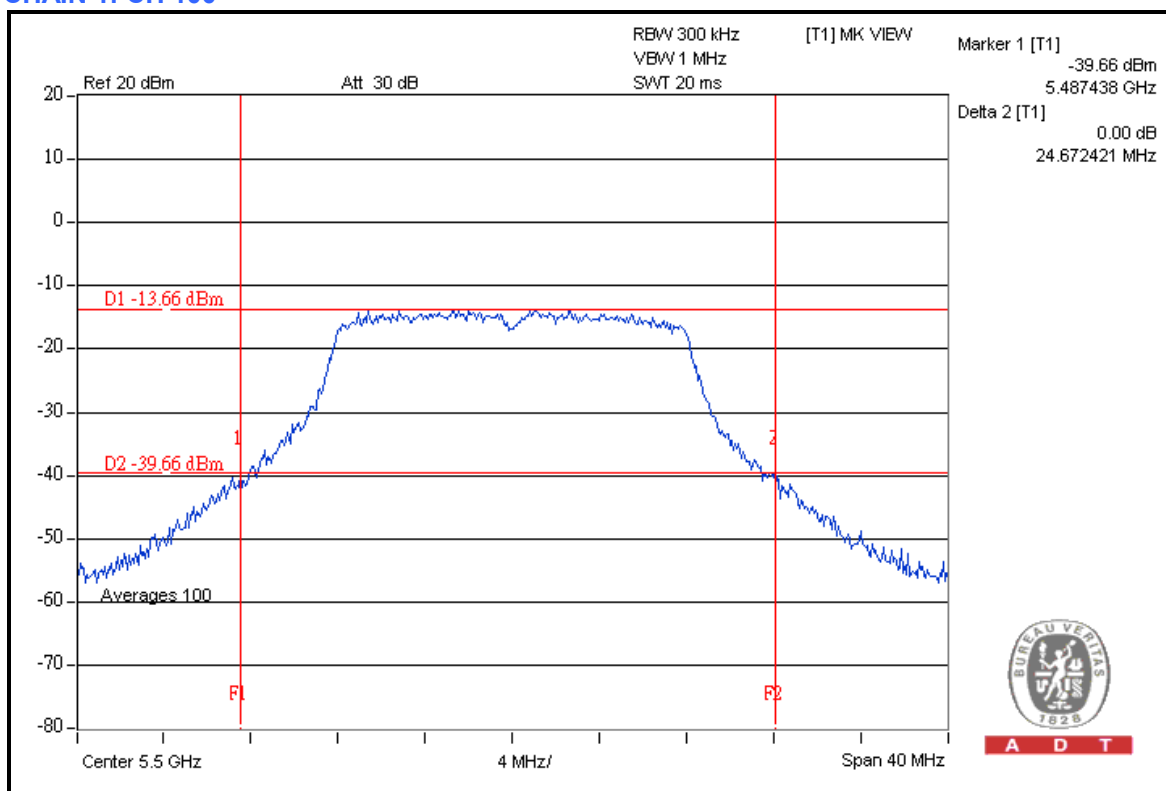

A D T



A D T

### 802.11n (20MHz)

For Mode A:

CHANNEL	CHANNEL FREQUENCY (MHz)	26dBc OCCUPIED BANDWIDTH (MHz)		PASS / FAIL
		CHAIN 0	CHAIN 1	
52	5260	24.1	23.4	PASS
60	5300	24.4	23.4	PASS
64	5320	24.4	23.5	PASS
100	5500	24.5	24.7	PASS
120	5600	24.7	25.4	PASS
140	5700	25.1	24.9	PASS

### CHAIN 1: CH 120

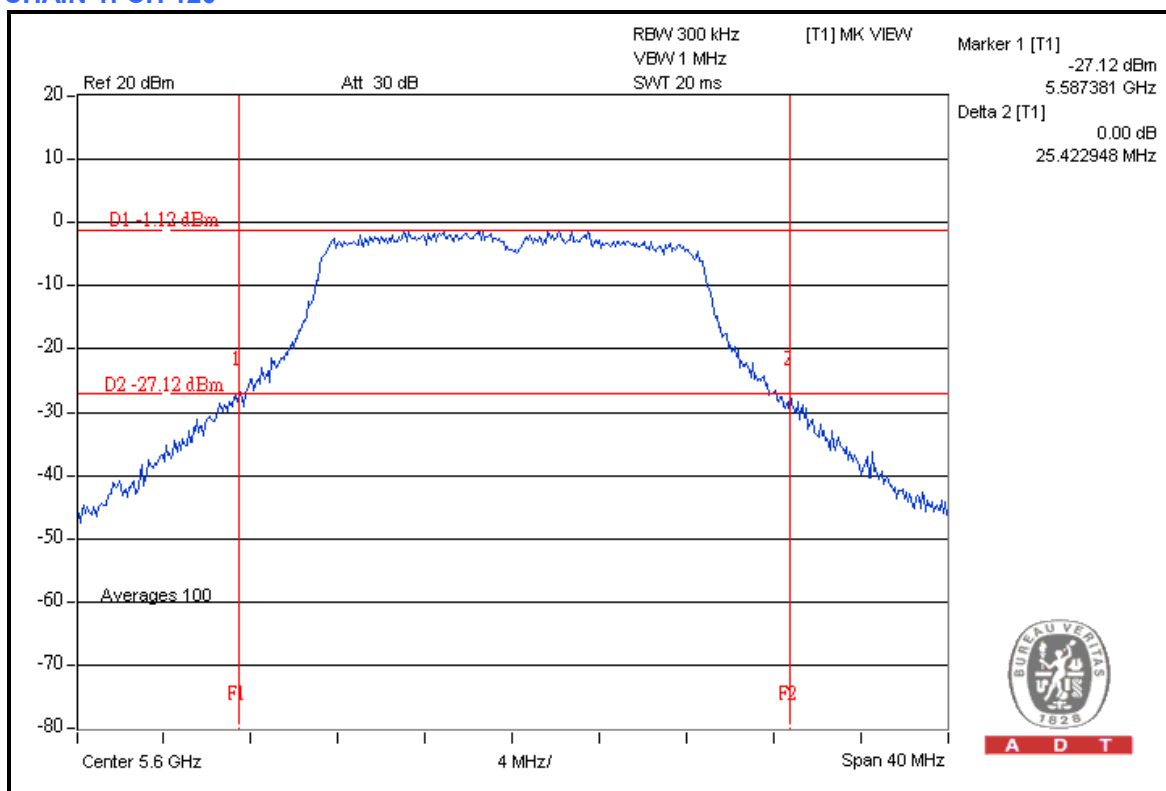

A D T



A D T

For Mode C:

CHANNEL	CHANNEL FREQUENCY (MHz)	26dBc OCCUPIED BANDWIDTH (MHz)		PASS / FAIL
		CHAIN 0	CHAIN 1	
52	5260	24.0	23.6	PASS
60	5300	24.3	22.9	PASS
64	5320	24.9	23.7	PASS
100	5500	24.7	23.8	PASS
120	5600	24.5	23.1	PASS
140	5700	27.2	23.5	PASS

CHAIN 0: CH 140

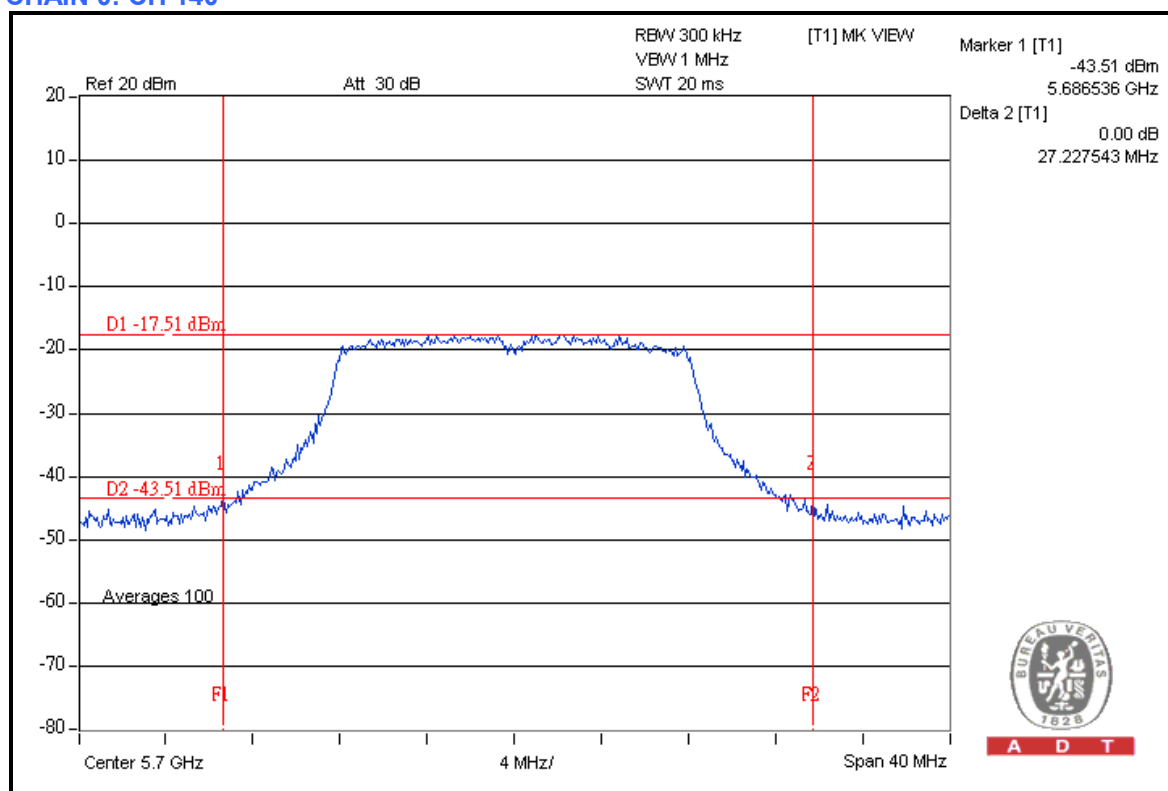



A D T

### 802.11n (40MHz)

For Mode A:

CHANNEL	CHANNEL FREQUENCY (MHz)	26dBc OCCUPIED BANDWIDTH (MHz)		PASS / FAIL
		CHAIN 0	CHAIN 1	
54	5270	46.9	47.4	PASS
62	5310	45.6	47.1	PASS
102	5510	46.5	46.4	PASS
118	5590	46.8	47.5	PASS
134	5670	46.7	47.0	PASS

### CHAIN 1: CH 118

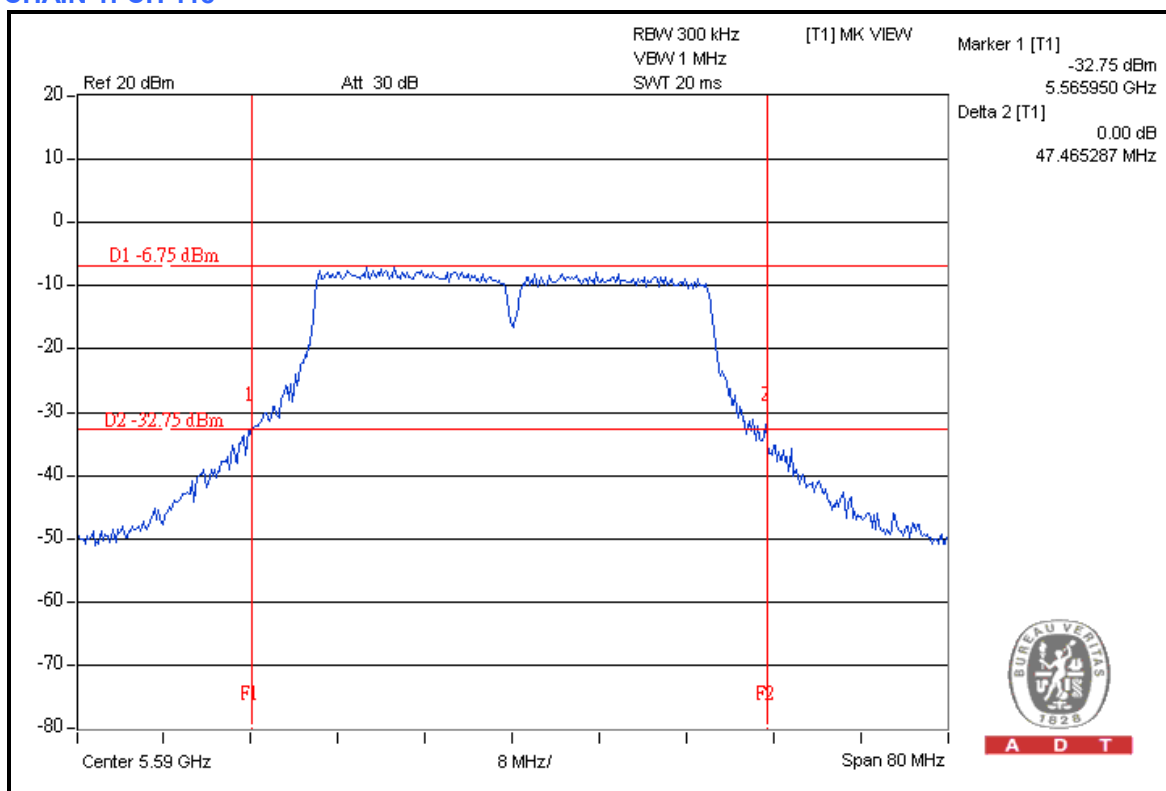





A D T

For Mode C:

CHANNEL	CHANNEL FREQUENCY (MHz)	26dBc OCCUPIED BANDWIDTH (MHz)		PASS / FAIL
		CHAIN 0	CHAIN 1	
54	5270	46.4	45.7	PASS
62	5310	50.5	47.4	PASS
102	5510	47.0	44.4	PASS
118	5590	46.1	46.2	PASS
134	5670	46.5	45.8	PASS

CHAIN 0: CH 62

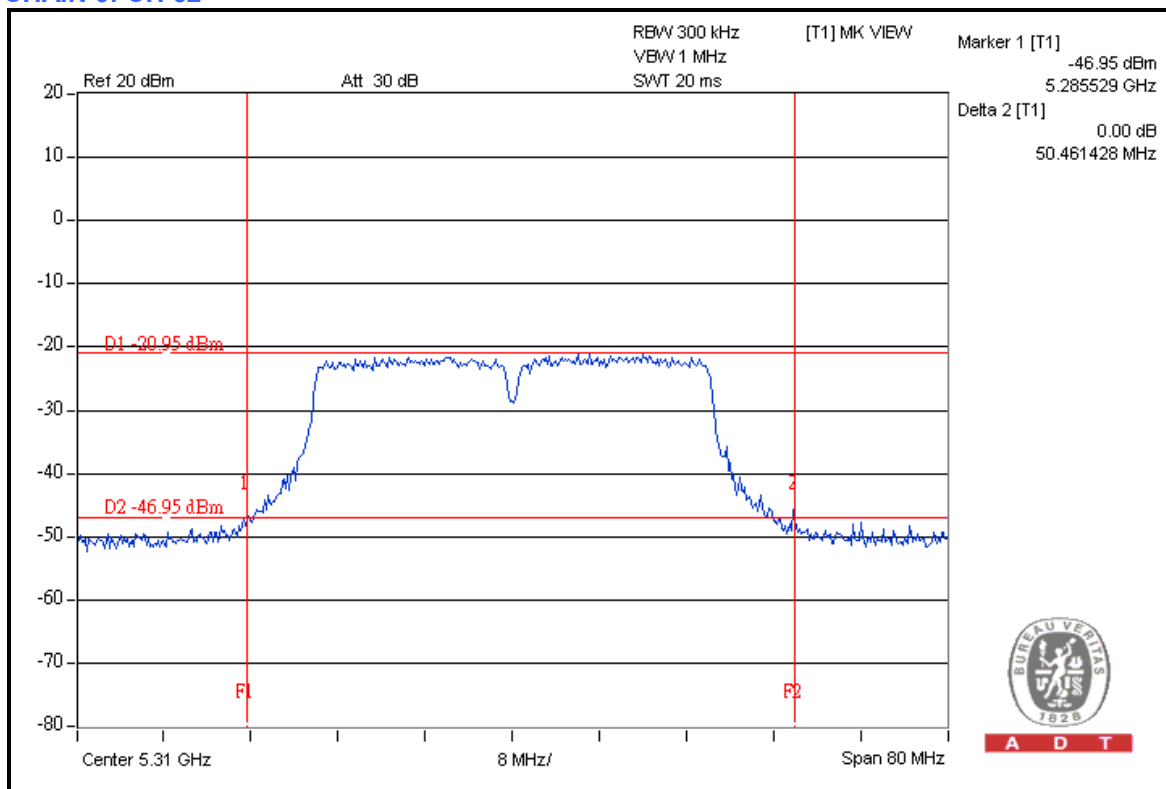

A D T

#### 4.4 PEAK POWER EXCURSION MEASUREMENT

##### 4.4.1 LIMITS OF PEAK POWER EXCURSION MEASUREMENT

FREQUENCY BAND	LIMIT
5.150 ~ 5.250GHz	13dB
5.250 ~ 5.350GHz	13dB
5.470 ~ 5.725GHz	13dB

##### 4.4.2 TEST INSTRUMENTS

DESCRIPTION & MANUFACTURER	MODEL NO.	SERIAL NO.	DATE OF CALIBRATION	DUE DATE OF CALIBRATION
SPECTRUM ANALYZER	FSP 40	100036	Apr. 3, 2009	Apr. 2, 2010

**NOTE:** The calibration interval of the above test instruments is 12 months and the calibrations are traceable to NML/ROC and NIST/USA.

##### 4.4.3 TEST PROCEDURE

- a. The transmitter output was connected to the spectrum analyzer.
- b. Set the spectrum bandwidth span to view the entire spectrum.
- c. Using peak detector and Max-hold function for Trace 1 (RB = 1MHz, VB = 3MHz) and 2 (RB = 1MHz, VB = 300 kHz).
- d. The differences between Trace1 and Trace 2 in any 1MHz band at f1 to f2 range were recorded and showed to another trace.

#### 4.4.4 DEVIATION FROM TEST STANDARD

No deviation

#### 4.4.5 TEST SETUP

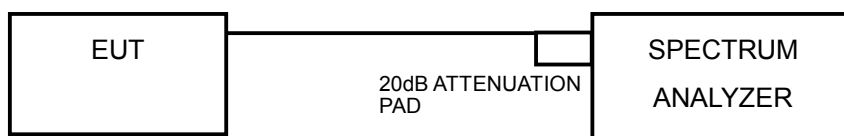

#### 4.4.6 EUT OPERATING CONDITIONS

The software provided by client to enable the EUT under transmission condition continuously at specific channel frequencies individually.



A D T

#### 4.4.7 TEST RESULTS

802.11a

For Mode A:

CHANNEL	CHANNEL FREQUENCY (MHz)	PEAK POWER EXCURSION (dB)		PEAK to AVERAGE EXCURSION LIMIT (dB)	PASS/FAIL
		CHAIN 0	CHAIN 1		
52	5260	8.5	8.4	13	PASS
60	5300	8.7	8.0	13	PASS
64	5320	8.8	8.7	13	PASS
100	5500	9.0	8.0	13	PASS
120	5600	8.2	8.1	13	PASS
140	5700	8.6	8.6	13	PASS



A D T

### CHAIN 0: CH 100

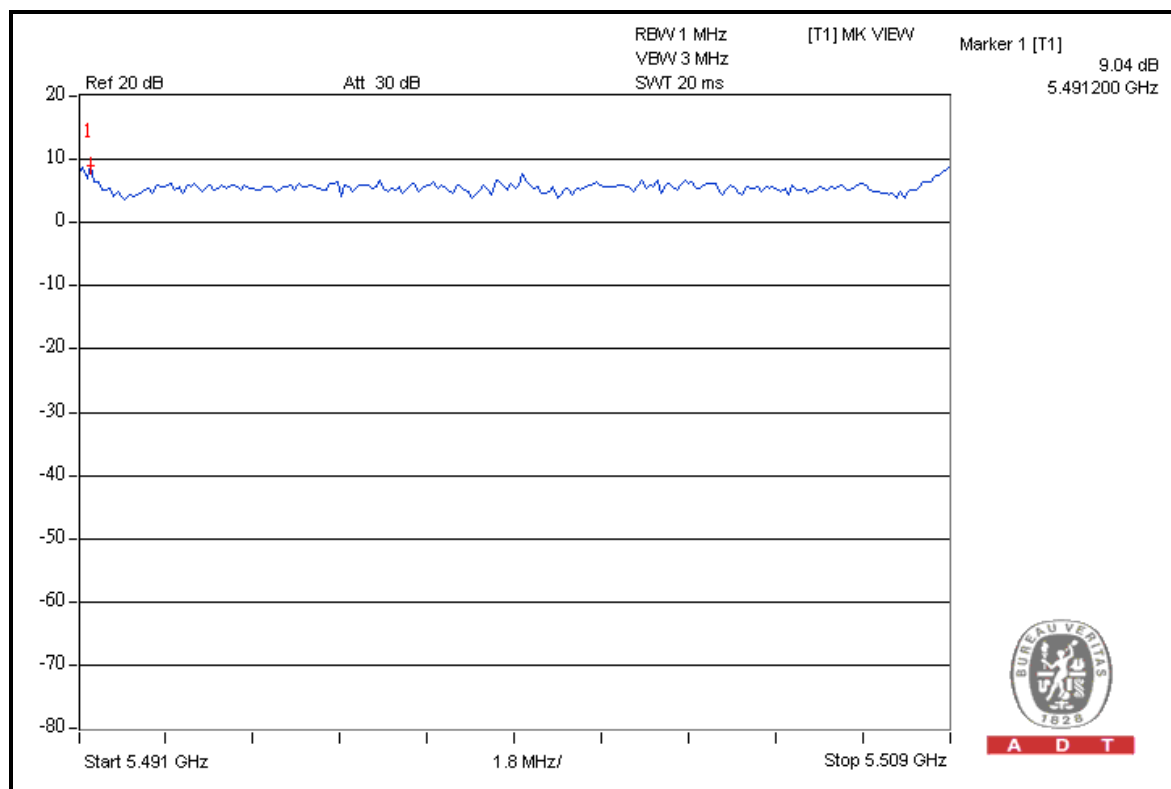
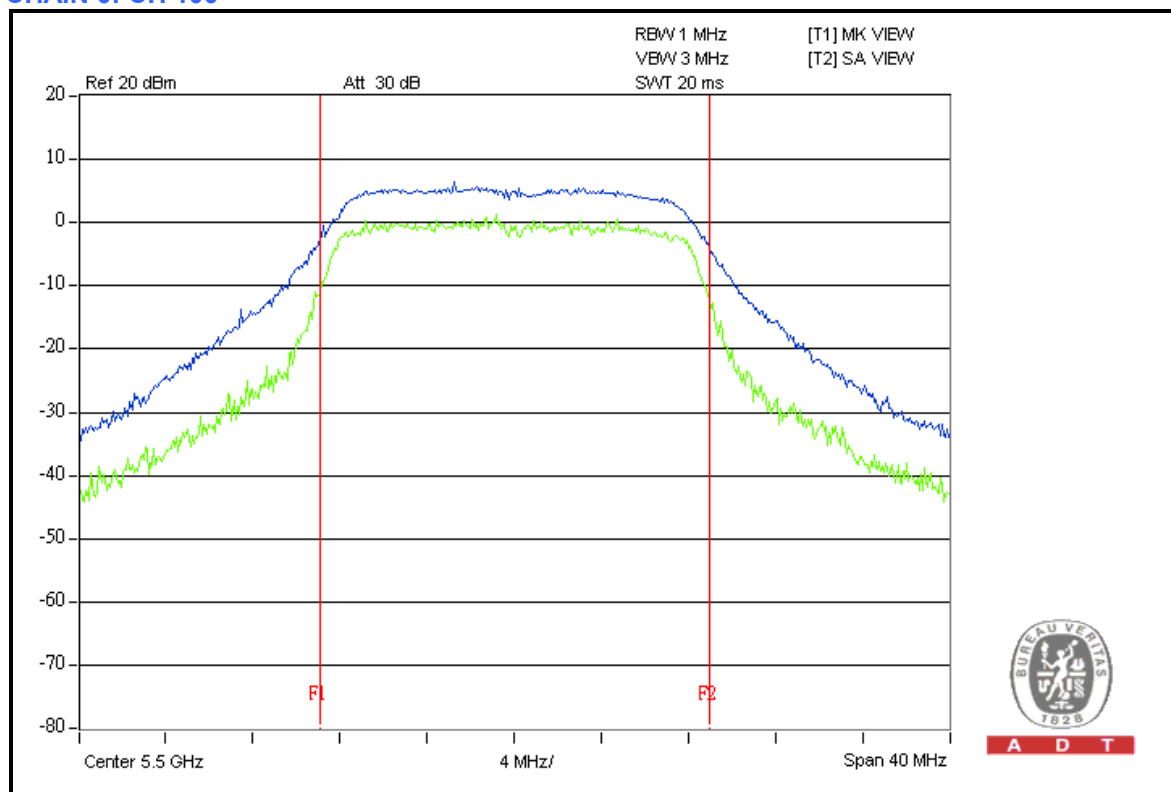



A D T

For Mode C:

CHANNEL	CHANNEL FREQUENCY (MHz)	PEAK POWER EXCURSION (dB)		PEAK to AVERAGE EXCURSION LIMIT (dB)	PASS/FAIL
		CHAIN 0	CHAIN 1		
52	5260	8.1	8.2	13	PASS
60	5300	8.2	8.8	13	PASS
64	5320	9.5	8.7	13	PASS
100	5500	9.0	8.5	13	PASS
120	5600	8.6	8.1	13	PASS
140	5700	10.3	8.1	13	PASS



A D T

### CHAIN 0: CH 140

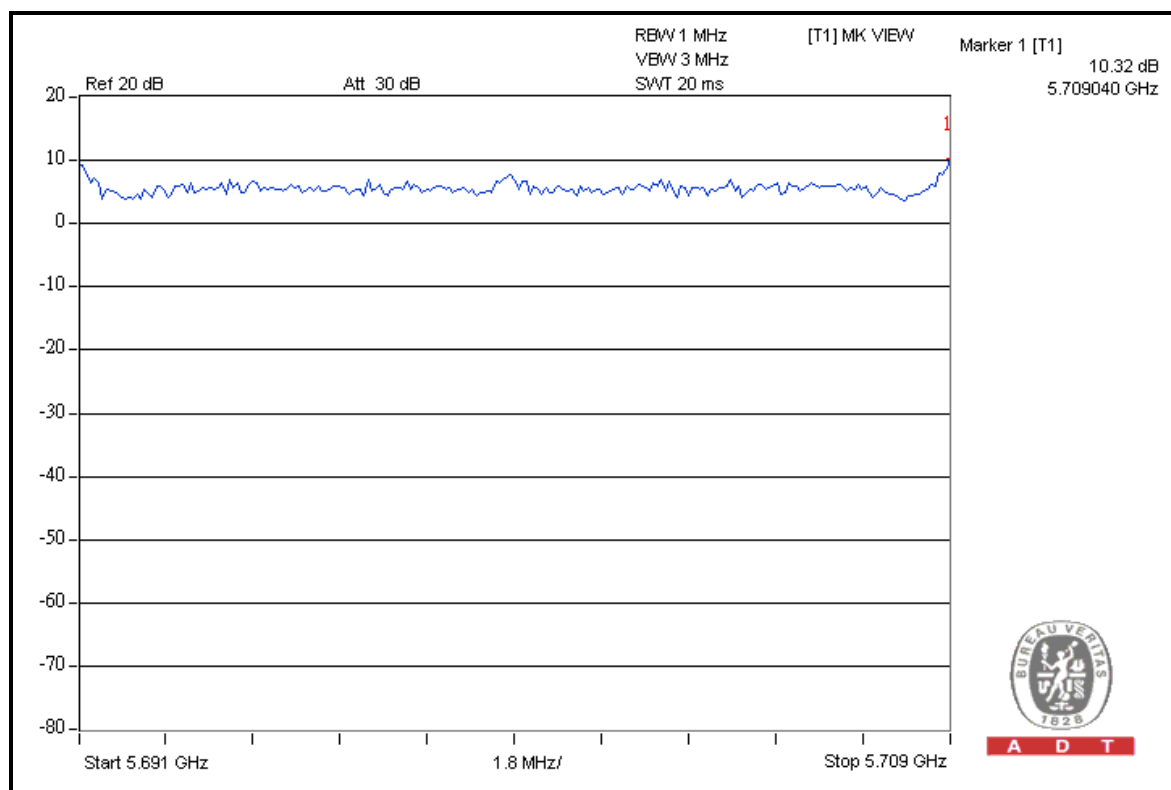
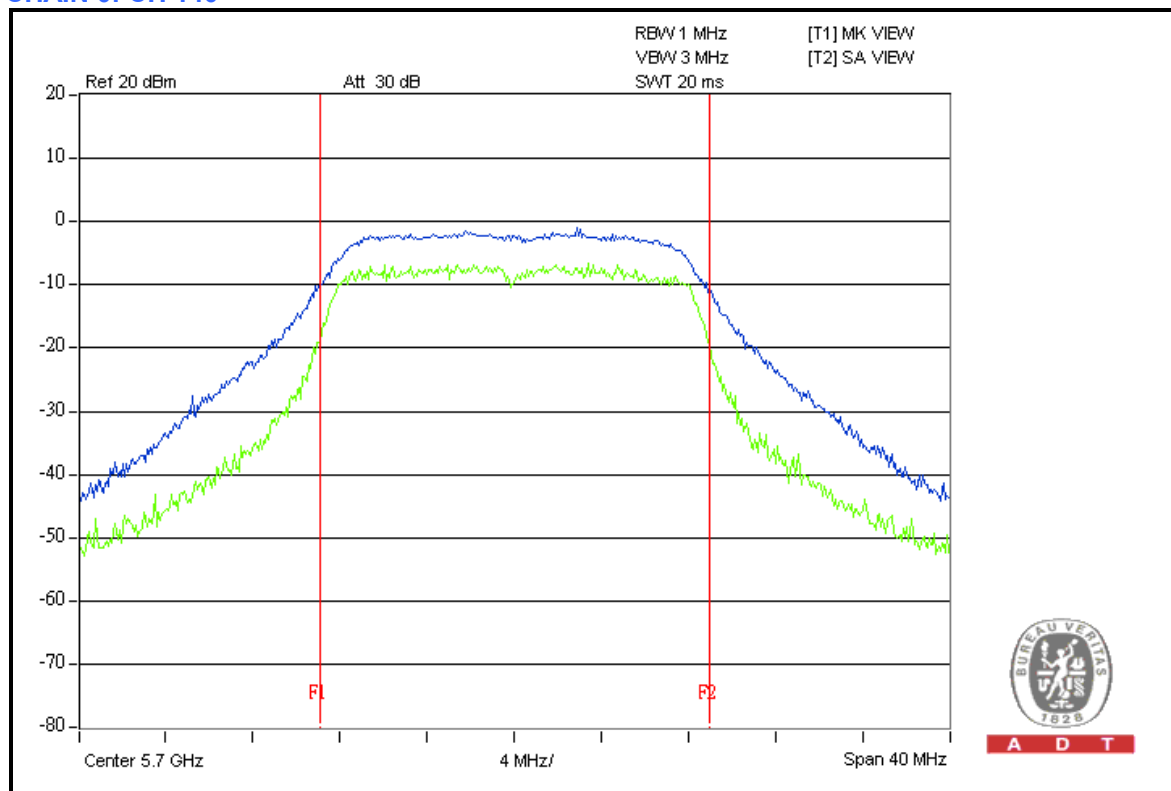



A D T

802.11n (20MHz)

For Mode A:

CHANNEL	CHANNEL FREQUENCY (MHz)	PEAK POWER EXCURSION (dB)		PEAK TO AVERAGE EXCURSION LIMIT (dB)	PASS/FAIL
		CHAIN 0	CHAIN 1		
52	5260	8.9	8.1	13	PASS
60	5300	8.4	7.7	13	PASS
64	5320	9.7	8.1	13	PASS
100	5500	8.4	9.2	13	PASS
120	5600	8.5	7.8	13	PASS
140	5700	10.0	8.1	13	PASS





A D T

### CHAIN 0: CH 140

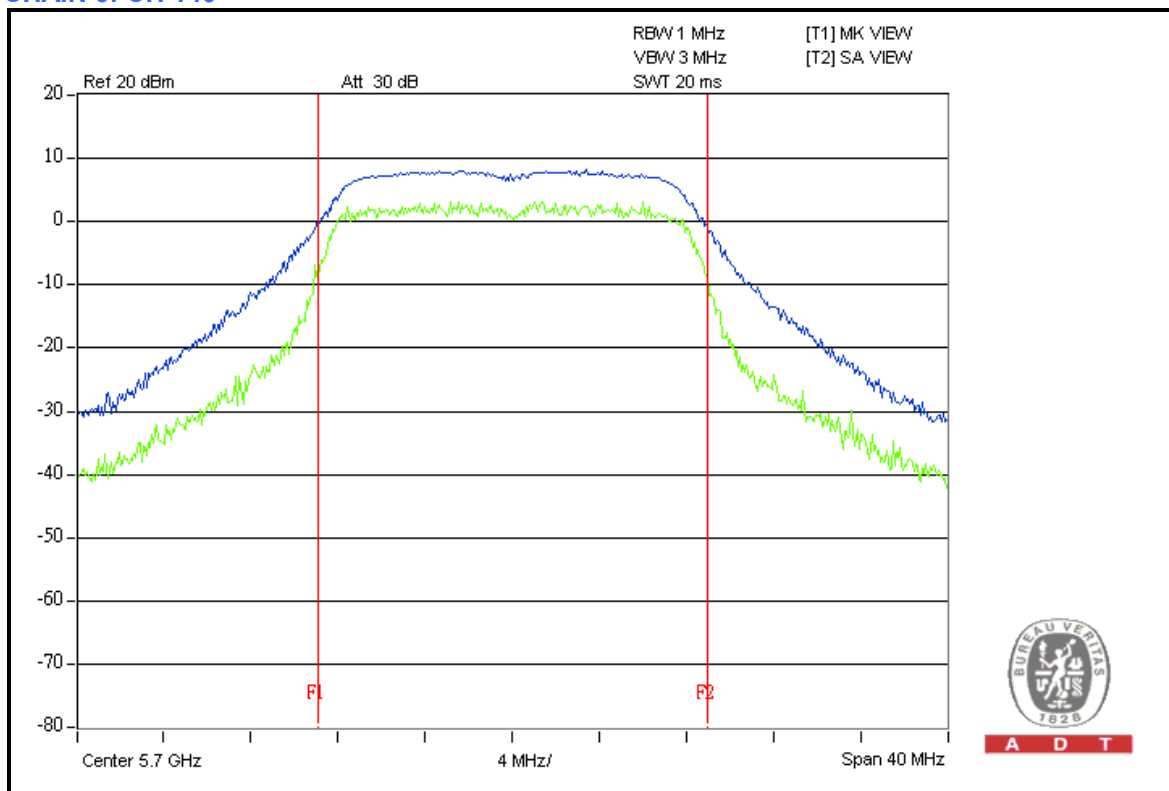

A D T

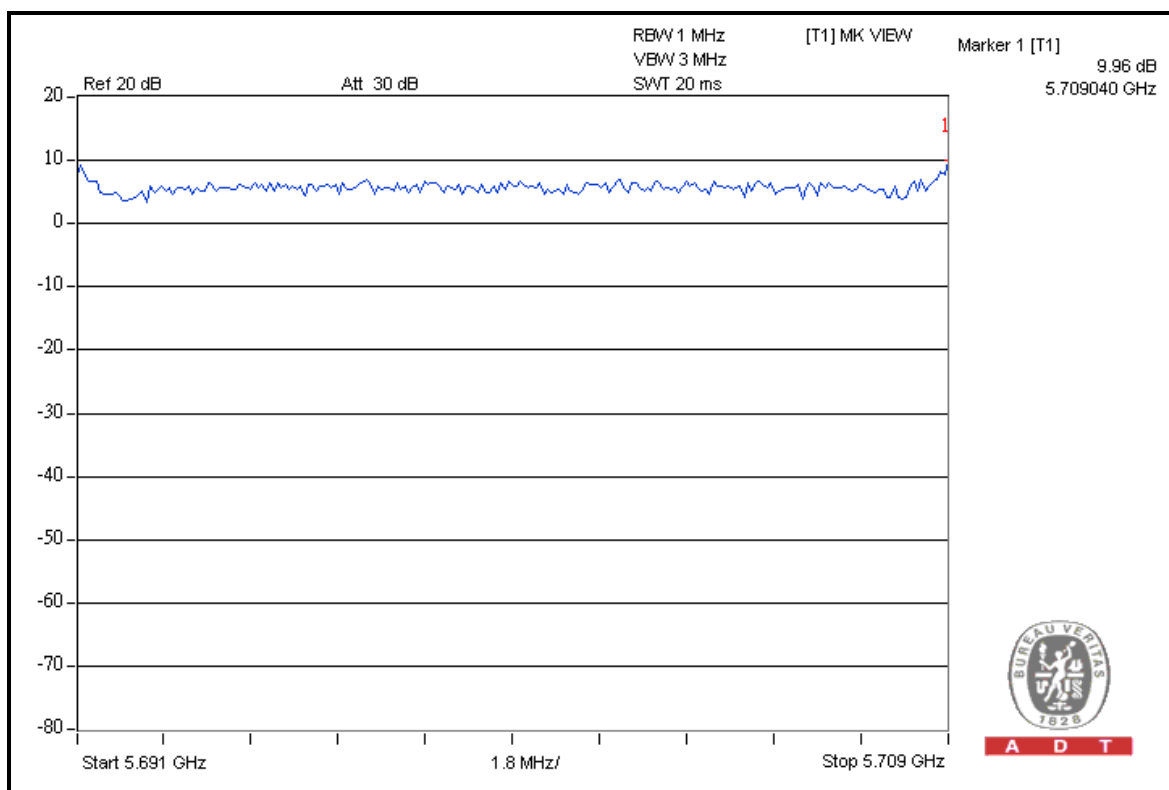

A D T



A D T

For Mode C:

CHANNEL	CHANNEL FREQUENCY (MHz)	PEAK POWER EXCURSION (dB)		PEAK TO AVERAGE EXCURSION LIMIT (dB)	PASS/FAIL
		CHAIN 0	CHAIN 1		
52	5260	8.9	8.2	13	PASS
60	5300	8.4	8.4	13	PASS
64	5320	8.9	8.3	13	PASS
100	5500	8.7	8.7	13	PASS
120	5600	10.2	7.6	13	PASS
140	5700	9.8	8.6	13	PASS



A D T

### CHAIN 0: CH 120

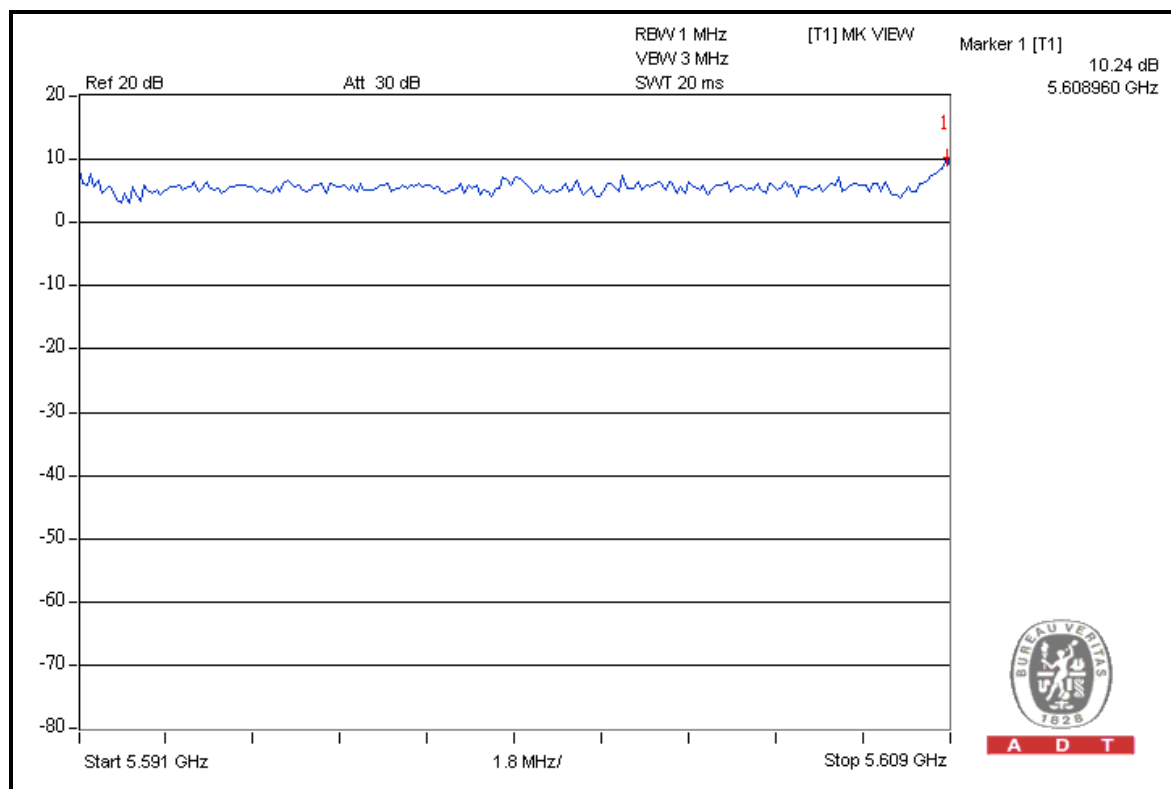
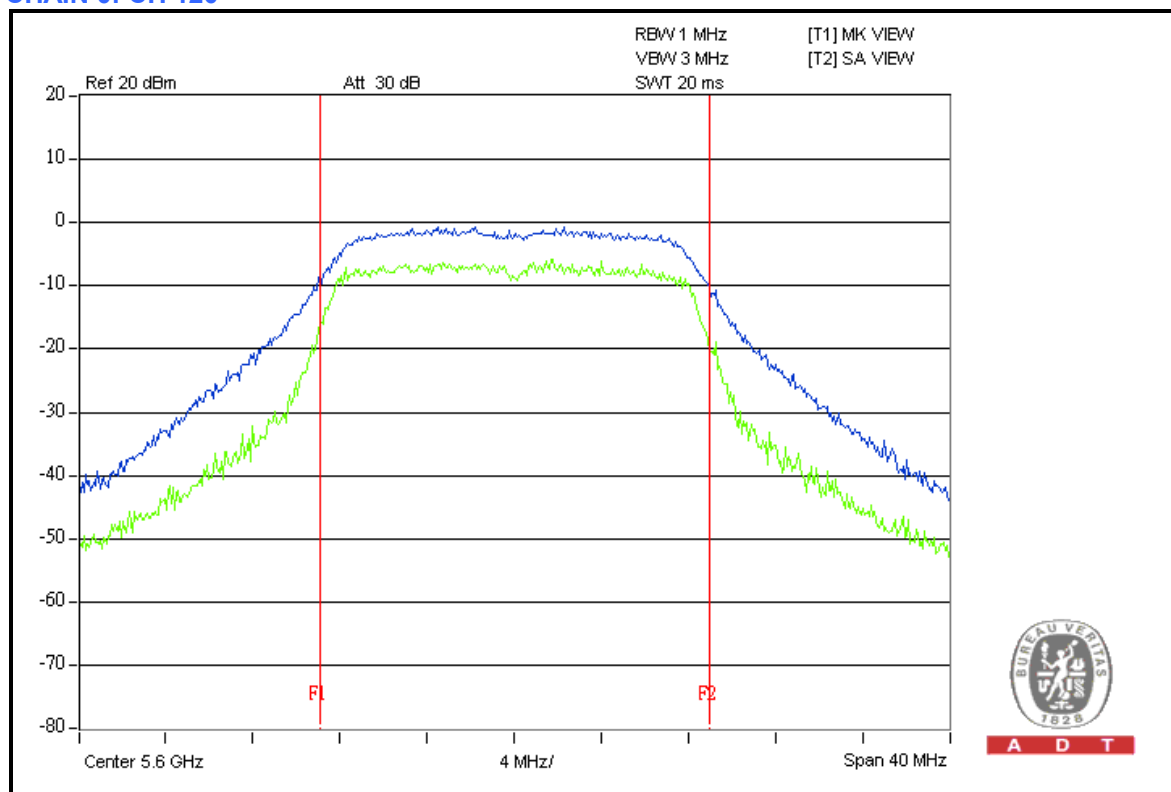



A D T

802.11n (40MHz)

For Mode A:

CHANNEL	CHANNEL FREQUENCY (MHz)	PEAK POWER EXCURSION (dB)		PEAK to AVERAGE EXCURSION LIMIT (dB)	PASS/FAIL
		CHAIN 0	CHAIN 1		
54	5270	8.2	9.2	13	PASS
62	5310	9.3	10.2	13	PASS
102	5510	8.9	11.1	13	PASS
118	5590	9.5	10.4	13	PASS
134	5670	10.1	11.0	13	PASS



A D T

### CHAIN 1: CH 102

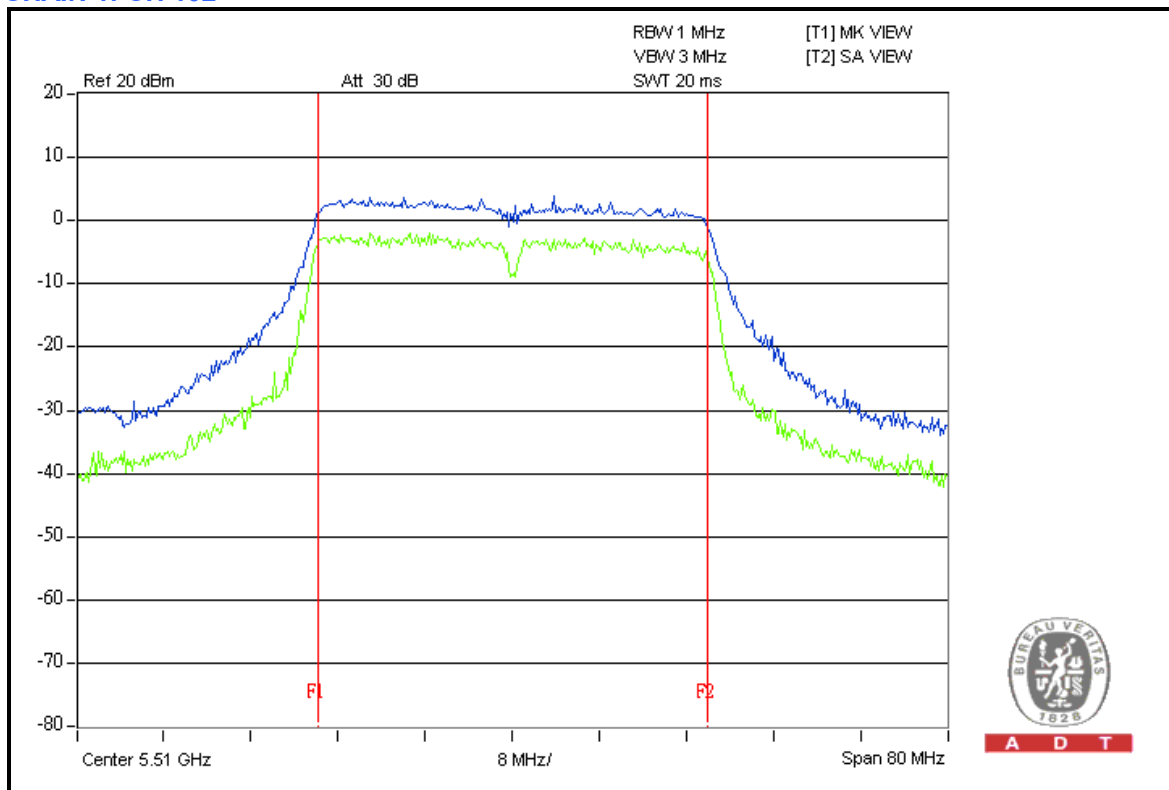

A D T

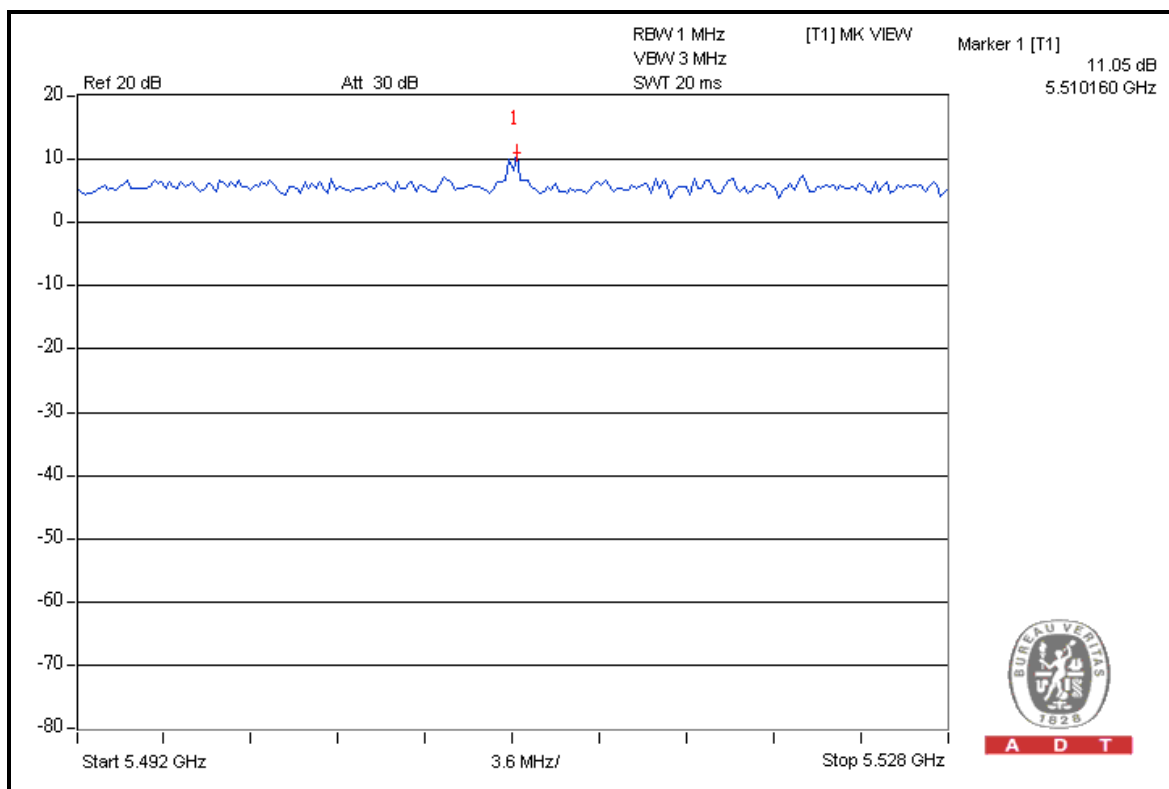

A D T



A D T

For Mode C:

CHANNEL	CHANNEL FREQUENCY (MHz)	PEAK POWER EXCURSION (dB)		PEAK to AVERAGE EXCURSION LIMIT (dB)	PASS/FAIL
		CHAIN 0	CHAIN 1		
54	5270	8.3	8.3	13	PASS
62	5310	11.1	10.6	13	PASS
102	5510	8.7	9.9	13	PASS
118	5590	9.7	9.3	13	PASS
134	5670	8.7	9.5	13	PASS



A D T

### CHAIN 0: CH 62

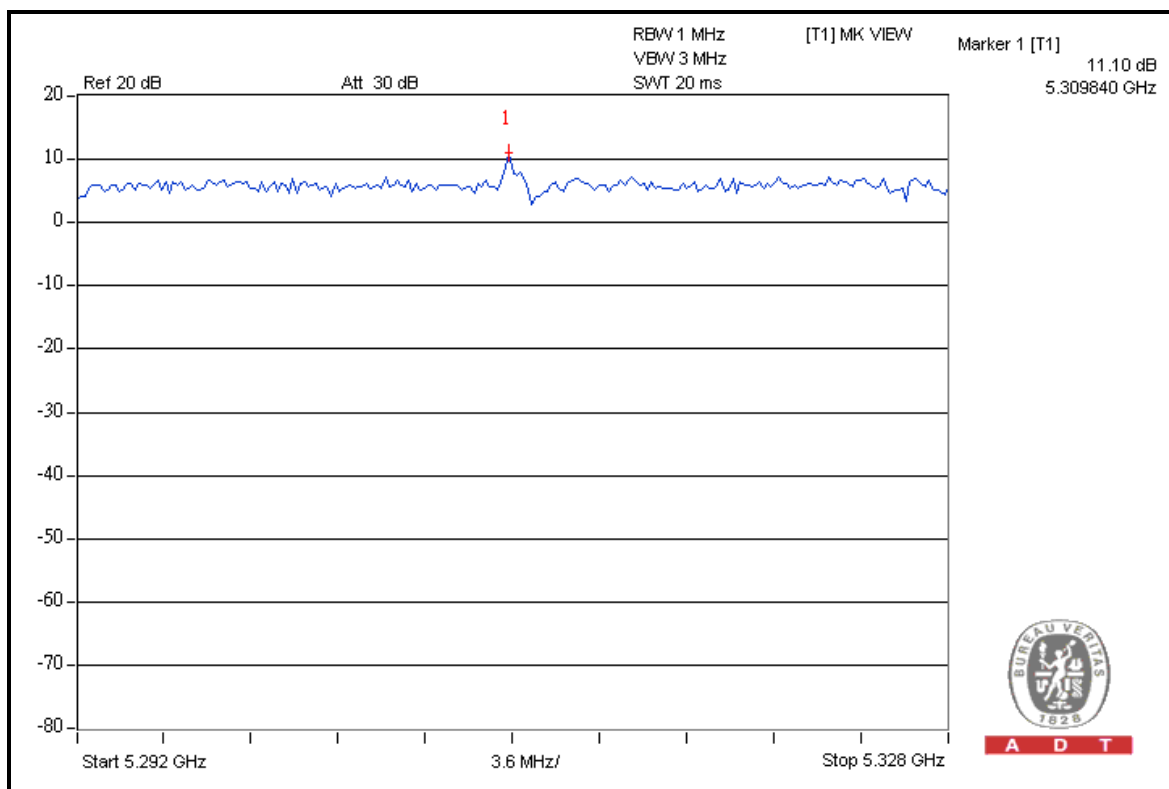
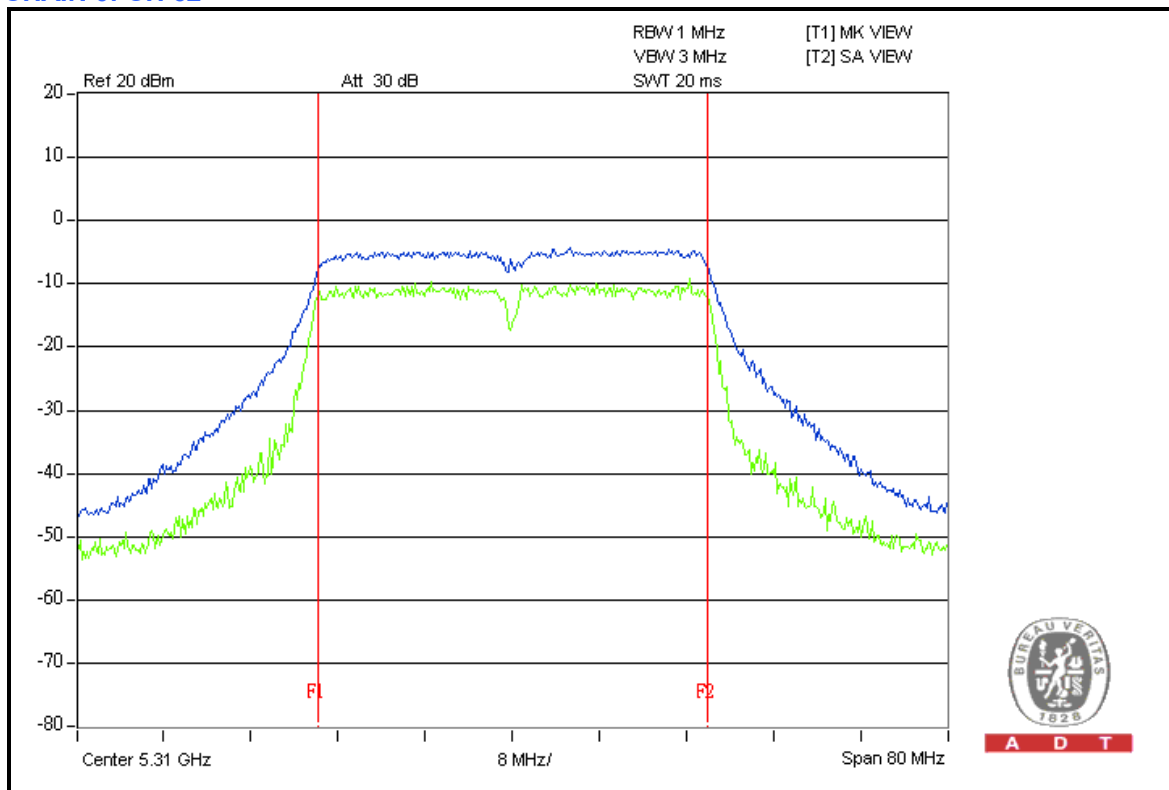

## 4.5 PEAK POWER SPECTRAL DENSITY MEASUREMENT

### 4.5.1 LIMITS OF PEAK POWER SPECTRAL DENSITY MEASUREMENT

FREQUENCY BAND	LIMIT
5.150 ~ 5.250GHz	4dBm
5.250 ~ 5.350GHz	11dBm
5.470 ~ 5.725GHz	11dBm

### 4.5.2 TEST INSTRUMENTS

DESCRIPTION & MANUFACTURER	MODEL NO.	SERIAL NO.	DATE OF CALIBRATION	DUE DATE OF CALIBRATION
SPECTRUM ANALYZER	FSP 40	100036	Apr. 3, 2009	Apr. 2, 2010

**NOTE:** The calibration interval of the above test instruments is 12 months and the calibrations are traceable to NML/ROC and NIST/USA.

### 4.5.3 TEST PROCEDURES

- a. The transmitter output was connected to the spectrum analyzer.
- b. Set RBW = 1MHz, VBW = 3MHz. The PPSD is the highest level found across the emission in any 1MHz band.



#### 4.5.4 DEVIATION FROM TEST STANDARD

No deviation

#### 4.5.5 TEST SETUP

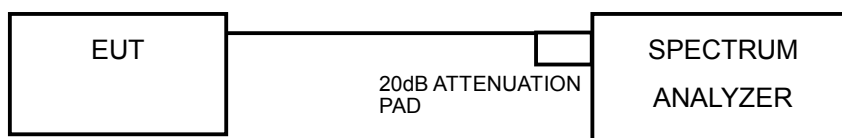

#### 4.5.6 EUT OPERATING CONDITIONS

Same as 4.4.6



A D T

### 4.5.7 TEST RESULTS

#### 802.11a

For Mode A:

CHAN.	CHAN. FREQ. (MHz)	RF POWER LEVEL IN 1MHz BW (dBm)		TOTAL POWER DENSITY (mW)	TOTAL POWER DENSITY (dBm)	MAX. LIMIT (dBm)	PASS / FAIL
		CHAIN 0	CHAIN 1				
52	5260	-2.0	-1.2	1.4	1.4	3	PASS
60	5300	-0.6	-1.6	1.6	1.9	3	PASS
64	5320	-7.8	-8.0	0.3	-4.9	3	PASS
100	5500	-5.6	-5.1	0.6	-2.3	3	PASS
120	5600	-2.3	-3.2	1.1	0.3	3	PASS
140	5700	-3.7	-5.2	0.7	-1.4	3	PASS

#### CHAIN 0: CH 60

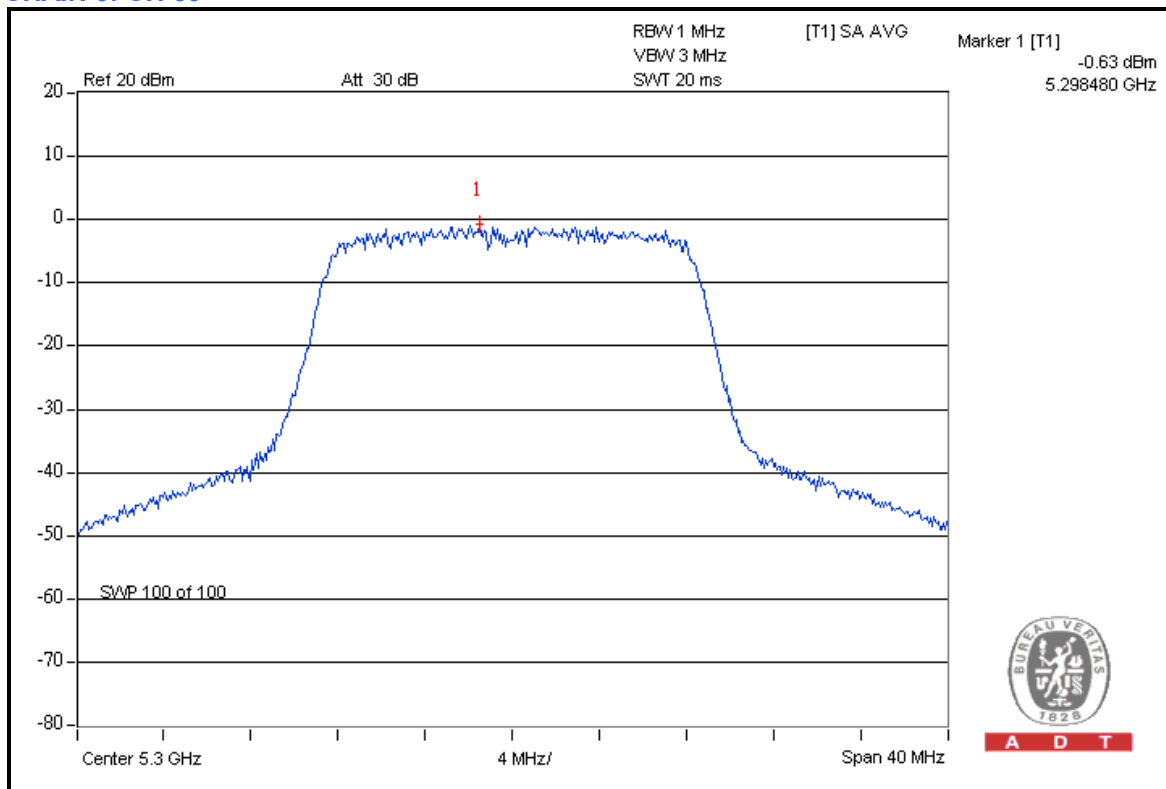

A D T



A D T

For Mode C:

CHAN.	CHAN. FREQ. (MHz)	RF POWER LEVEL IN 1MHz BW (dBm)		TOTAL POWER DENSITY (mW)	TOTAL POWER DENSITY (dBm)	MAX. LIMIT (dBm)	PASS / FAIL
		CHAIN 0	CHAIN 1				
52	5260	-13.4	-14.6	0.1	-11.0	-6	PASS
60	5300	-12.5	-13.2	0.1	-9.8	-6	PASS
64	5320	-17.7	-17.0	0.0	-14.3	-6	PASS
100	5500	-12.8	-13.7	0.1	-10.2	-6	PASS
120	5600	-12.3	-13.6	0.1	-9.9	-6	PASS
140	5700	-12.2	-13.0	0.1	-9.6	-6	PASS

CHAIN 0: CH 140

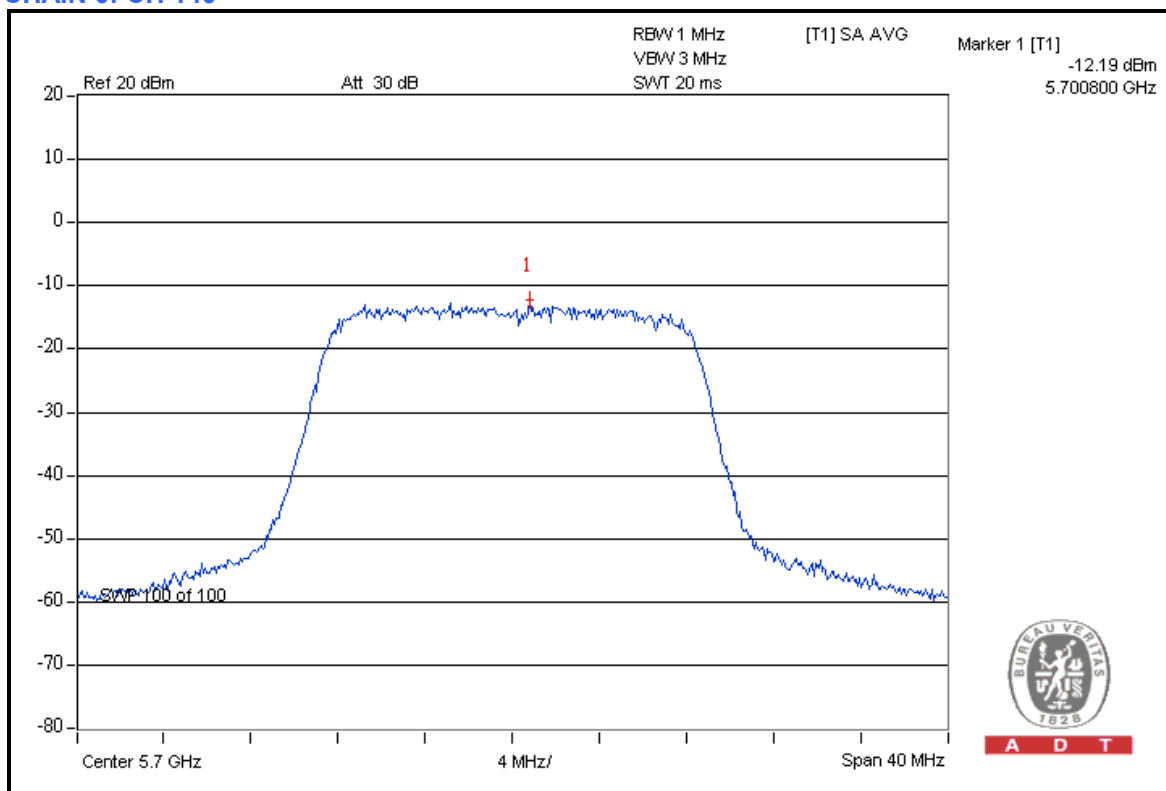



A D T

### 802.11n (20MHz)

For Mode A:

CHAN.	CHAN. FREQ. (MHz)	RF POWER LEVEL IN 1MHz BW (dBm)		TOTAL POWER DENSITY (mW)	TOTAL POWER DENSITY (dBm)	MAX. LIMIT (dBm)	PASS / FAIL
		CHAIN 0	CHAIN 1				
52	5260	-0.3	-0.5	1.8	2.6	3	PASS
60	5300	-0.9	-0.5	1.7	2.3	3	PASS
64	5320	-6.5	-6.8	0.4	-3.6	3	PASS
100	5500	-4.3	-4.1	0.8	-1.2	3	PASS
120	5600	-1.2	-2.2	1.4	1.3	3	PASS
140	5700	-2.6	-4.3	0.9	-0.4	3	PASS

### CHAIN 0: CH 52

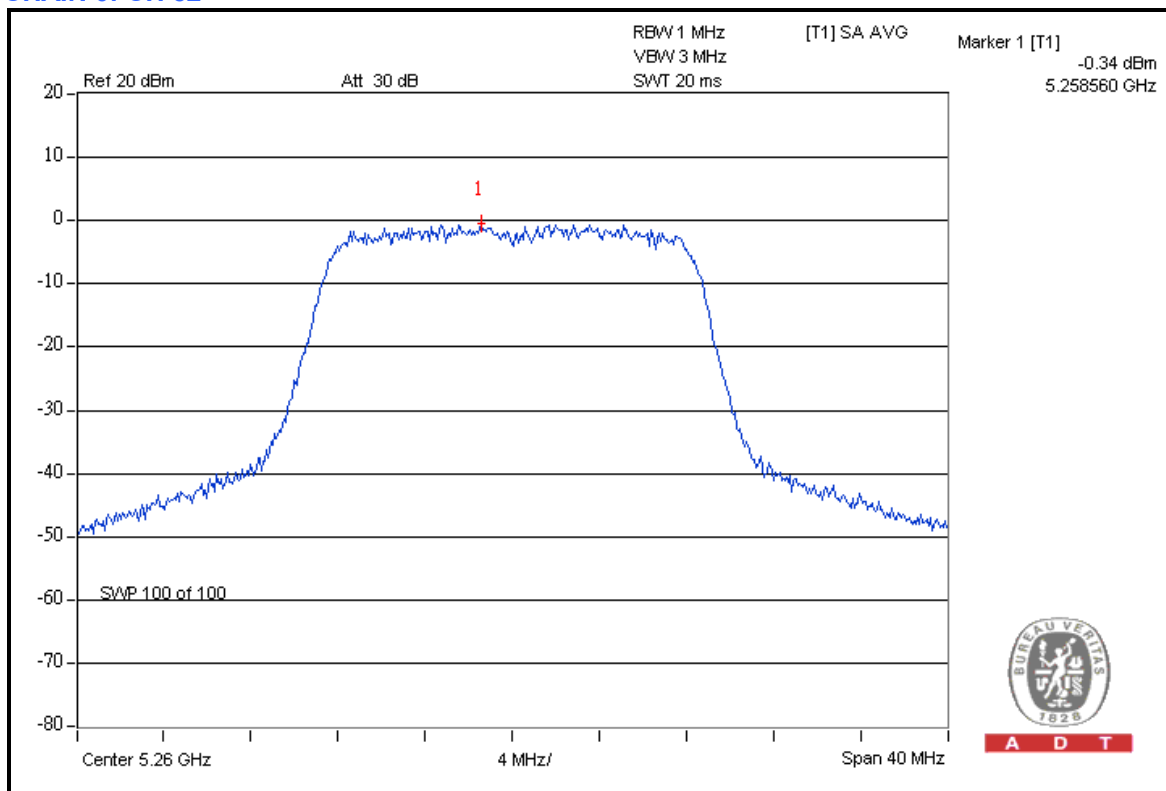

A D T



A D T

For Mode C:

CHAN.	CHAN. FREQ. (MHz)	RF POWER LEVEL IN 1MHz BW (dBm)		TOTAL POWER DENSITY (mW)	TOTAL POWER DENSITY (dBm)	MAX. LIMIT (dBm)	PASS / FAIL
		CHAIN 0	CHAIN 1				
52	5260	-12.7	-13.8	0.1	-10.2	-6	PASS
60	5300	-11.8	-13.1	0.1	-9.4	-6	PASS
64	5320	-17.7	-17.0	0.0	-14.3	-6	PASS
100	5500	-12.8	-12.7	0.1	-9.7	-6	PASS
120	5600	-11.9	-13.0	0.1	-9.4	-6	PASS
140	5700	-12.5	-12.7	0.1	-9.6	-6	PASS

CHAIN 0: CH 60

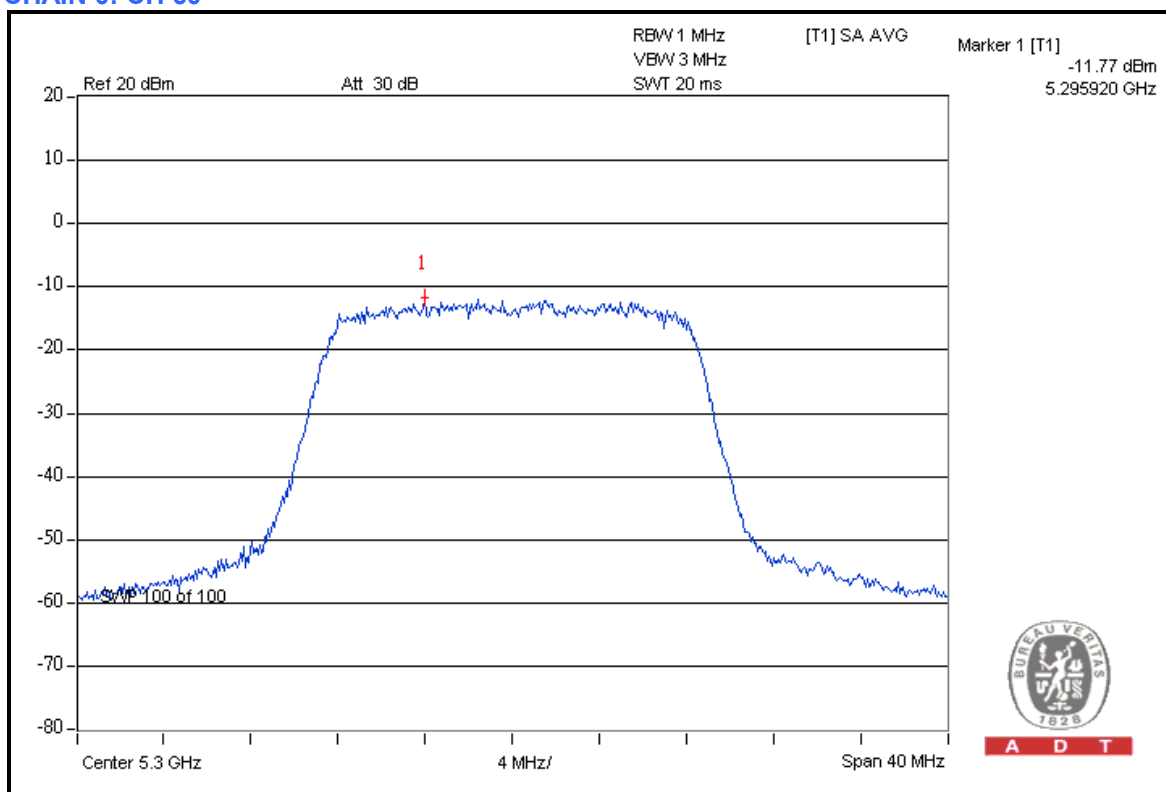

A D T



A D T

### 802.11n (40MHz)

For Mode A:

CHAN.	CHAN. FREQ. (MHz)	RF POWER LEVEL IN 1MHz BW (dBm)		TOTAL POWER DENSITY (mW)	TOTAL POWER DENSITY (dBm)	MAX. LIMIT (dBm)	PASS / FAIL
		CHAIN 0	CHAIN 1				
54	5270	-3.9	-4.7	0.7	-1.3	3	PASS
62	5310	-10.5	-10.8	0.2	-7.6	3	PASS
102	5510	-8.7	-8.4	0.3	-5.5	3	PASS
118	5590	-6.0	-6.2	0.5	-3.1	3	PASS
134	5670	-6.9	-8.2	0.4	-4.5	3	PASS

### CHAIN 0: CH 54

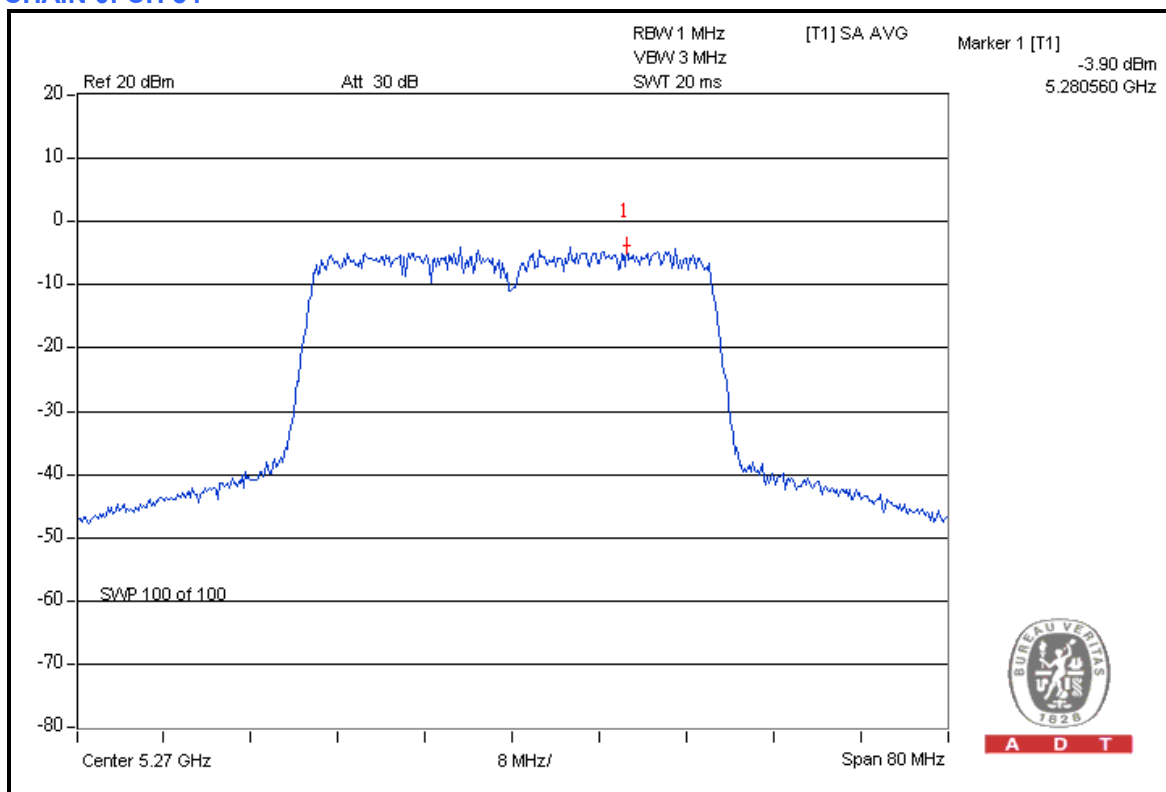

A D T



A D T

For Mode C:

CHAN.	CHAN. FREQ. (MHz)	RF POWER LEVEL IN 1MHz BW (dBm)		TOTAL POWER DENSITY (mW)	TOTAL POWER DENSITY (dBm)	MAX. LIMIT (dBm)	PASS / FAIL
		CHAIN 0	CHAIN 1				
54	5270	-17.0	-17.2	0.0	-14.1	-6	PASS
62	5310	-16.4	-20.0	0.0	-14.8	-6	PASS
102	5510	-16.8	-16.9	0.0	-13.8	-6	PASS
118	5590	-15.6	-16.4	0.1	-13.0	-6	PASS
134	5670	-15.3	-17.1	0.0	-13.1	-6	PASS

CHAIN 0: CH 134

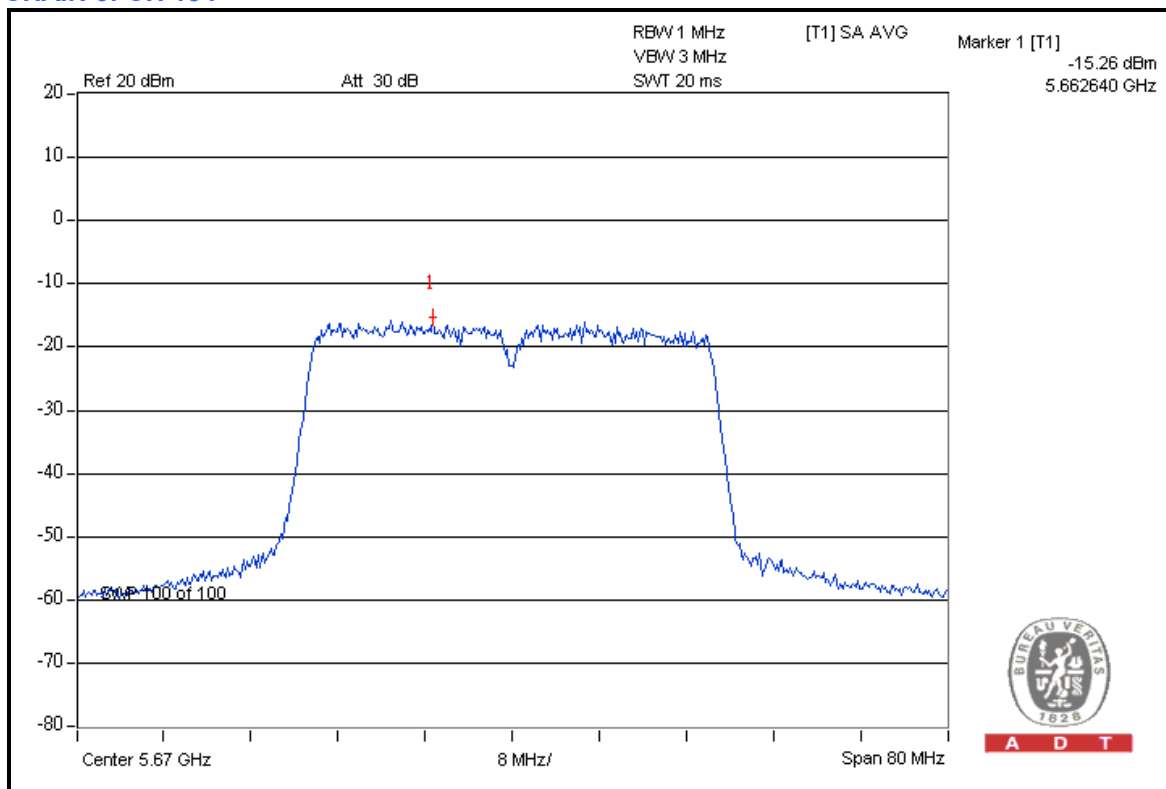

## 4.6 FREQUENCY STABILITY

### 4.6.1 LIMITS OF FREQUENCY STABILITY MEASUREMENT

The frequency tolerance of the carrier signal shall be maintained within the band of the operating frequency over a temperature variation of  $-40$  degrees to  $65$  degrees C at normal supply voltage, and for a variation in the primary supply voltage from 85% to 115% of the rated supply voltage at a temperature of  $20$  degrees C.

### 4.6.2 TEST INSTRUMENTS

DESCRIPTION & MANUFACTURER	MODEL NO.	SERIAL NO.	DATE OF CALIBRATION	DUE DATE OF CALIBRATION
SPECTRUM ANALYZER	FSP 40	100036	Apr. 3, 2009	Apr. 2, 2010
Temperature & Humidity Chamber	MHU-225AU	920409	Apr. 30, 2009	Apr. 29, 2010

**NOTE:** The calibration interval of the above test instruments is 12 months and the calibrations are traceable to NML/ROC and NIST/USA.

### 4.6.3 TEST PROCEDURE

- a. The EUT was placed inside the environmental test chamber and powered by nominal DC voltage.
- b. Turn the EUT on and couple its output to a spectrum analyzer.
- c. Turn the EUT off and set the chamber to the highest temperature specified.
- d. Allow sufficient time (approximately 30 min) for the temperature of the chamber to stabilize, turn the EUT on and measure the operating frequency after 2, 5, and 10 minutes.
- e. Repeat step b and c with the temperature chamber set to the lowest temperature.
- f. The test chamber was allowed to stabilize at  $+20$  degree C for a minimum of 30 minutes. The supply voltage was then adjusted on the EUT from 85% to 115% and the frequency record.



#### 4.6.4 DEVIATION FROM TEST STANDARD

No deviation

#### 4.6.5 TEST SETUP

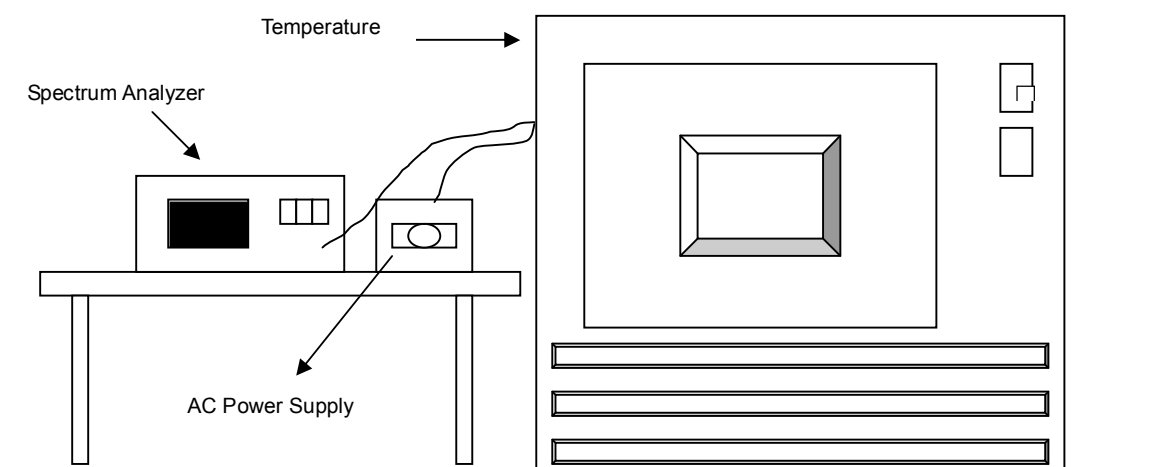

#### 4.6.6 EUT OPERATING CONDITION

Same as Item 4.1.7



A D T

### 4.6.7 TEST RESULTS

For Mode A:

FREQUENCY STABILITY VERSUS TEMP.									
OPERATING FREQUENCY: 5320MHz									
TEMP. (°C)	POWER SUPPLY (Vac)	0 MINUTE		2 MINUTE		5 MINUTE		10 MINUTE	
		Measured Frequency (MHz)	Frequency Drift (%)	Measured Frequency (MHz)	Frequency Drift (%)	Measured Frequency (MHz)	Frequency Drift (%)	Measured Frequency (MHz)	Frequency Drift (%)
65	120.0	5319.968498	-0.0005921	5319.968438	-0.0005933	5319.96885	-0.0005855	5319.968255	-0.0005967
50	120.0	5319.968024	-0.0006011	5319.967855	-0.0006042	5319.967973	-0.0006020	5319.967992	-0.0006017
40	120.0	5319.968428	-0.0005935	5319.96827	-0.0005964	5319.968206	-0.0005976	5319.968418	-0.0005936
30	120.0	5319.968458	-0.0005929	5319.968427	-0.0005935	5319.968462	-0.0005928	5319.968592	-0.0005904
20	120.0	5319.968548	-0.0005912	5319.968549	-0.0005912	5319.968584	-0.0005905	5319.968533	-0.0005915
10	120.0	5319.968193	-0.0005979	5319.968239	-0.0005970	5319.968347	-0.0005950	5319.968305	-0.0005958
0	120.0	5319.968424	-0.0005935	5319.968593	-0.0005904	5319.968589	-0.0005904	5319.968336	-0.0005952
-10	120.0	5319.968477	-0.0005925	5319.968477	-0.0005925	5319.968352	-0.0005949	5319.968427	-0.0005935
-20	120.0	5319.968175	-0.0005982	5319.968188	-0.0005980	5319.968329	-0.0005953	5319.968408	-0.0005938
-30	120.0	5319.968115	-0.0005993	5319.96791	-0.0006032	5319.968219	-0.0005974	5319.967948	-0.0006025
-40	120.0	5319.968109	-0.0005995	5319.968379	-0.0005944	5319.968255	-0.0005967	5319.967758	-0.0006061

FREQUENCY STABILITY VERSUS VOLTAGE									
OPERATING FREQUENCY: 5320MHz									
TEMP. (°C)	POWER SUPPLY (Vac)	0 MINUTE		2 MINUTE		5 MINUTE		10 MINUTE	
		Measured Frequency (MHz)	Frequency Drift (%)	Measured Frequency (MHz)	Frequency Drift (%)	Measured Frequency (MHz)	Frequency Drift (%)	Measured Frequency (MHz)	Frequency Drift (%)
20	138.0	5319.968158	-0.0005985	5319.968204	-0.0005977	5319.968254	-0.0005967	5319.968362	-0.0005947
	120.0	5319.968548	-0.0005912	5319.968549	-0.0005912	5319.968584	-0.0005905	5319.968533	-0.0005915
	102.0	5319.968388	-0.0005942	5319.96835	-0.0005949	5319.968242	-0.0005970	5319.968555	-0.0005911



A D T

**For Mode C:**

FREQUENCY STABILITY VERSUS TEMP.									
OPERATING FREQUENCY: 5320MHz									
TEMP. (°C)	POWER SUPPLY (Vac)	0 MINUTE		2 MINUTE		5 MINUTE		10 MINUTE	
		Measured Frequency (MHz)	Frequency Drift (%)	Measured Frequency (MHz)	Frequency Drift (%)	Measured Frequency (MHz)	Frequency Drift (%)	Measured Frequency (MHz)	Frequency Drift (%)
65	120.0	5319.969053	-0.0005817	5319.968933	-0.0005840	5319.968292	-0.0005960	5319.968444	-0.0005932
50	120.0	5319.968292	-0.0005960	5319.968022	-0.0006011	5319.968374	-0.0005945	5319.968263	-0.0005966
40	120.0	5319.968392	-0.0005941	5319.968419	-0.0005936	5319.968163	-0.0005984	5319.968299	-0.0005959
30	120.0	5319.968531	-0.0005915	5319.968225	-0.0005973	5319.968227	-0.0005972	5319.968688	-0.0005886
20	120.0	5319.968773	-0.0005870	5319.968867	-0.0005852	5319.968651	-0.0005893	5319.968768	-0.0005871
10	120.0	5319.968171	-0.0005983	5319.96819	-0.0005979	5319.968122	-0.0005992	5319.968117	-0.0005993
0	120.0	5319.968604	-0.0005901	5319.968545	-0.0005913	5319.968558	-0.0005910	5319.968899	-0.0005846
-10	120.0	5319.968378	-0.0005944	5319.96841	-0.0005938	5319.968438	-0.0005933	5319.968373	-0.0005945
-20	120.0	5319.968274	-0.0005964	5319.968341	-0.0005951	5319.96824	-0.0005970	5319.968411	-0.0005938
-30	120.0	5319.96838	-0.0005944	5319.968581	-0.0005906	5319.968281	-0.0005962	5319.968436	-0.0005933
-40	120.0	5319.96861	-0.0005900	5319.968317	-0.0005955	5319.968404	-0.0005939	5319.968562	-0.0005909

FREQUENCY STABILITY VERSUS VOLTAGE									
OPERATING FREQUENCY: 5320MHz									
TEMP. (°C)	POWER SUPPLY (Vac)	0 MINUTE		2 MINUTE		5 MINUTE		10 MINUTE	
		Measured Frequency (MHz)	Frequency Drift (%)	Measured Frequency (MHz)	Frequency Drift (%)	Measured Frequency (MHz)	Frequency Drift (%)	Measured Frequency (MHz)	Frequency Drift (%)
20	138.0	5319.968344	-0.0005950	5319.968092	-0.0005998	5319.968342	-0.0005951	5319.968362	-0.0005947
	120.0	5319.968773	-0.0005870	5319.968867	-0.0005852	5319.968651	-0.0005893	5319.968768	-0.0005871
	102.0	5319.968308	-0.0005957	5319.968258	-0.0005967	5319.968345	-0.0005950	5319.968023	-0.0006011



## 4.7 BAND EDGES MEASUREMENT

### 4.7.1 TEST INSTRUMENTS

DESCRIPTION & MANUFACTURER	MODEL NO.	SERIAL NO.	CALIBRATED DATE	CALIBRATED UNTIL
Agilent Spectrum	8564EC	4208A00659	Jul. 24, 2009	Jul. 23, 2010
Agilent Preamplifier	8449B	3008A01924	Aug. 31, 2009	Aug. 30, 2010
Agilent Preamplifier	8449B	3008A01292	Aug. 10, 2009	Aug. 09, 2010
MITEQ Preamplifier	AMF-6F-2604 00-33-8P	892164	Aug. 31, 2009	Aug. 30, 2010
Schwarzbeck Horn Antenna	BBHA-9170	BBHA9170190	Sep. 24, 2009	Sep. 23, 2010
Schwarzbeck Horn Antenna	BBHA-9120	D130	May 15, 2009	May 14, 2010
ADT. Turn Table	TT100	0201	NA	NA
ADT. Tower	AT100	0201	NA	NA
Software	ADT_Radiate d_V7.6.15.9.2	NA	NA	NA
SUHNER RF cable	SF106-18	PHACAB-1G-40 GHz	Aug. 20, 2009	Aug. 19, 2010

- NOTE:**
1. The calibration interval of the above test instruments is 12 months. And the calibrations are traceable to NML/ROC and NIST/USA.
  2. The test was performed in Open Site No. 10.
  3. The Industry Canada Reference No. IC 7450E-10.
  4. The FCC Site Registration No. 698148.

#### 4.7.2 TEST PROCEDURE

- a. The EUT was placed on the top of a rotating table 0.8 meters above the ground at a 10-meter open area test site. The table was rotated 360 degrees to determine the position of the highest radiation.
- b. The EUT was set 3 meters away from the interference-receiving antenna, which was mounted on the top of a variable-height antenna tower.
- c. The antenna is a broadband antenna, and its height is varied from one meter to four meters above the ground to determine the maximum value of the field strength. Both horizontal and vertical polarizations of the antenna are set to make the measurement.
- d. For each suspected emission, the EUT was arranged to its worst case and then the antenna was tuned to heights from 1 meter to 4 meters and the rotatable table was turned from 0 degrees to 360 degrees to find the maximum reading.
- e. Set both RBW and VBW of spectrum analyzer to 1MHz and 3MHz with suitable frequency span including 100MHz bandwidth from band edge. The band edges was measured and recorded.

**NOTE:** The resolution bandwidth of test receiver/spectrum analyzer is 1MHz and the video bandwidth is 10Hz for Average detection (AV) at frequency above 1GHz.

#### 4.7.3 EUT OPERATING CONDITION

The software provided by client to enable the EUT under transmission condition continuously at specific channel frequencies individually.

#### 4.7.4 TEST RESULTS

For signals in the restricted bands above and below the 5.26 to 5.32GHz and 5.50 to 5.70GHz allocated band a measurement was made of the amplitude of the spurious emissions with respect to the intentional signals. The relative amplitude, in dBc, was applied to the average and peak field strength of the intentional signal made on the OATS to calculate the field strength of the unintentional signals.

The spectrum plots (Peak RBW = 1MHz, VBW = 3MHz) are attached on the following pages.

#### FOR 5260-5320MHz BAND: 802.11a

##### For Mode A:

##### RESTRICT BAND (4500 ~ 5150 MHz)

FREQUENCY (MHz)	FUNDAMENTAL EMISSION (dBuV/m)	DELTA (dB)	MAXIMUM FIELD STRENGTH IN RESTRICT BAND (dBuV/m)	LIMIT (dBuV/m)
5260.00 (PK)	121.6	58.1	63.5	74.00
5260.00 (AV)	111.3	60.3	51.0	54.00

##### RESTRICT BAND (5350 ~ 5460 MHz)

FREQUENCY (MHz)	FUNDAMENTAL EMISSION (dBuV/m)	DELTA (dB)	MAXIMUM FIELD STRENGTH IN RESTRICT BAND (dBuV/m)	LIMIT (dBuV/m)
5320.00 (PK)	116.5	54.1	62.4	74.00
5320.00 (AV)	105.6	56.8	48.8	54.00

##### NOTE:

1. Delta = Amplitude between the peak of the fundamental and the peak of the band edge emission. Please check following 3 pages.
2. Maximum field strength in restrict band = Fundamental emission – Delta.



A D T

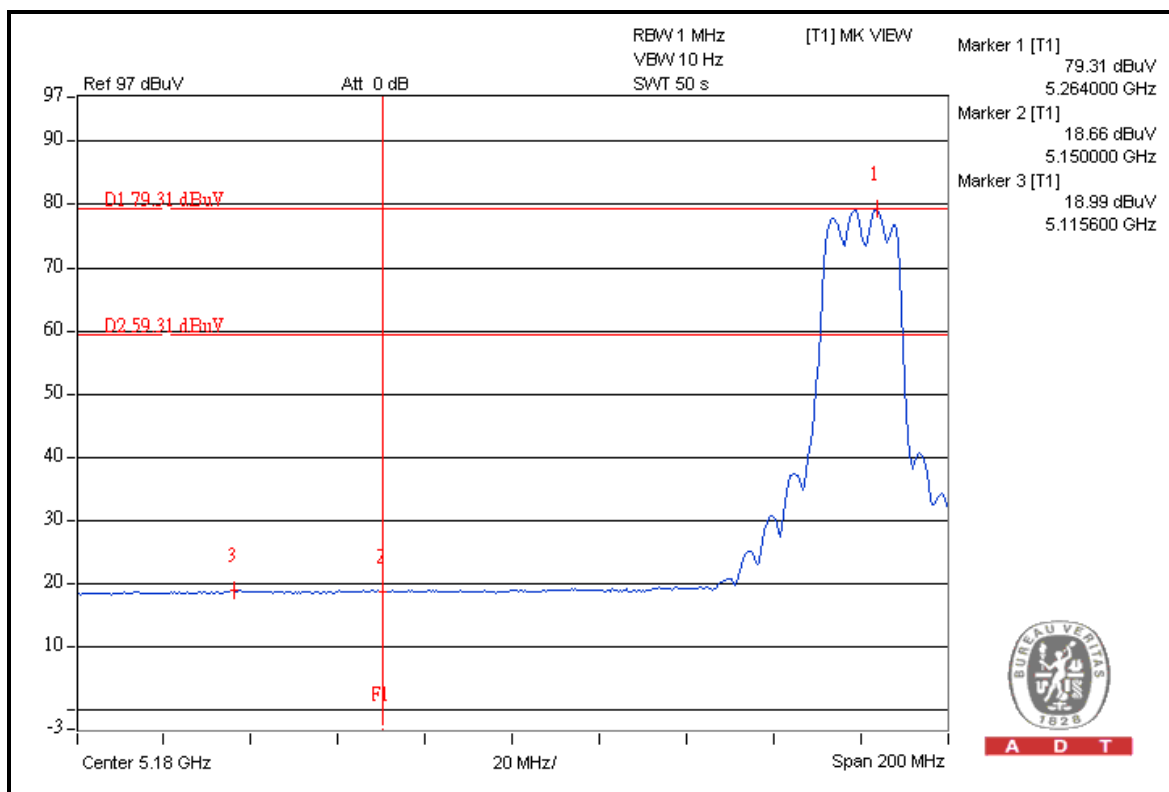
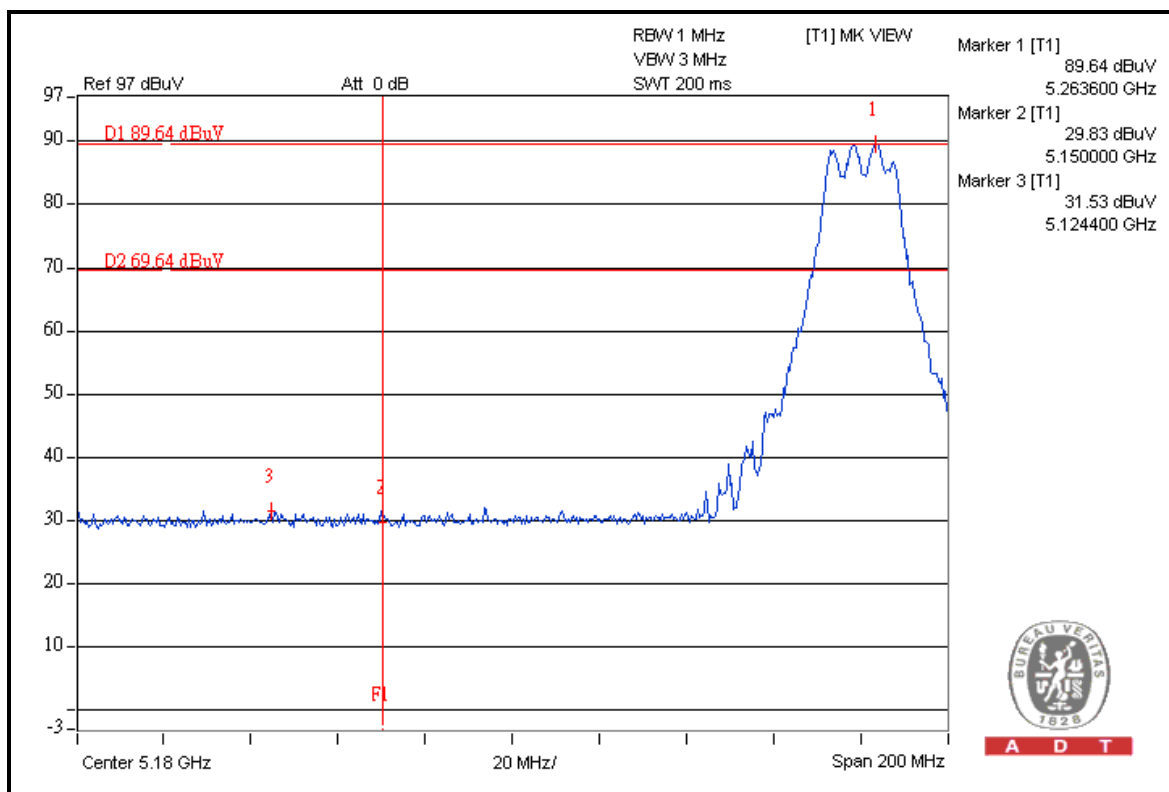



A D T

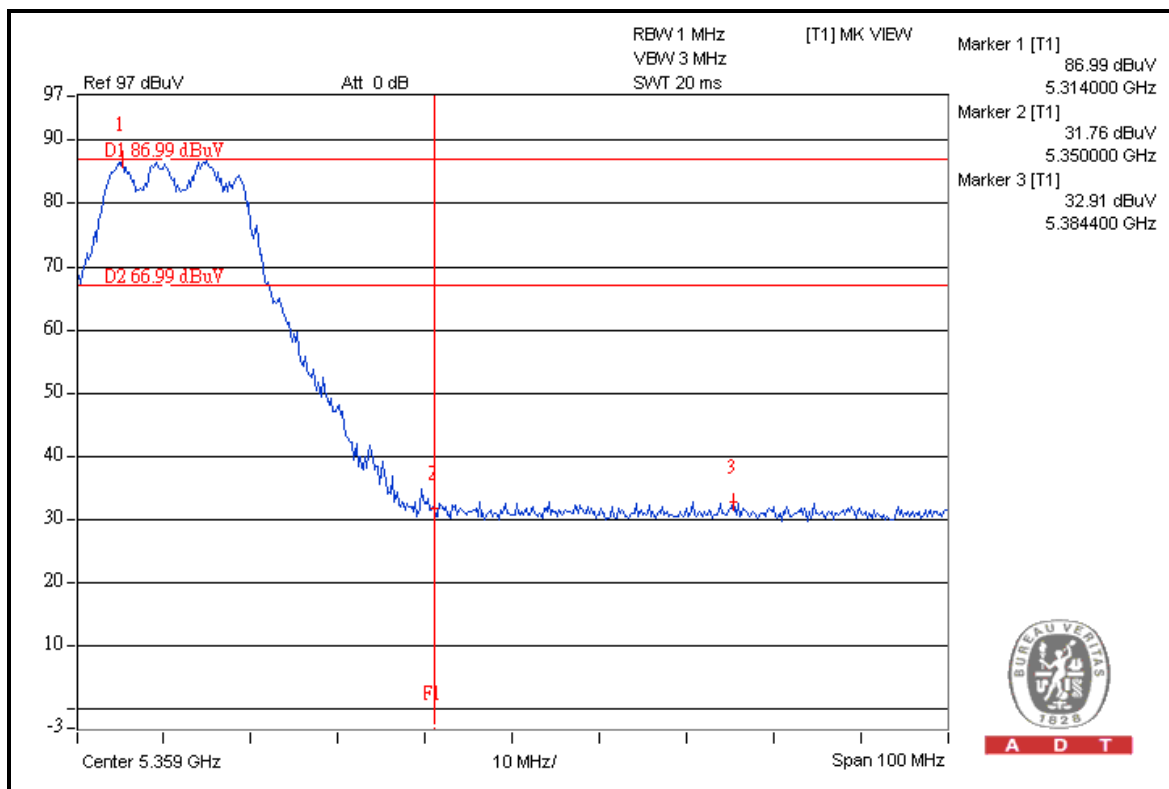
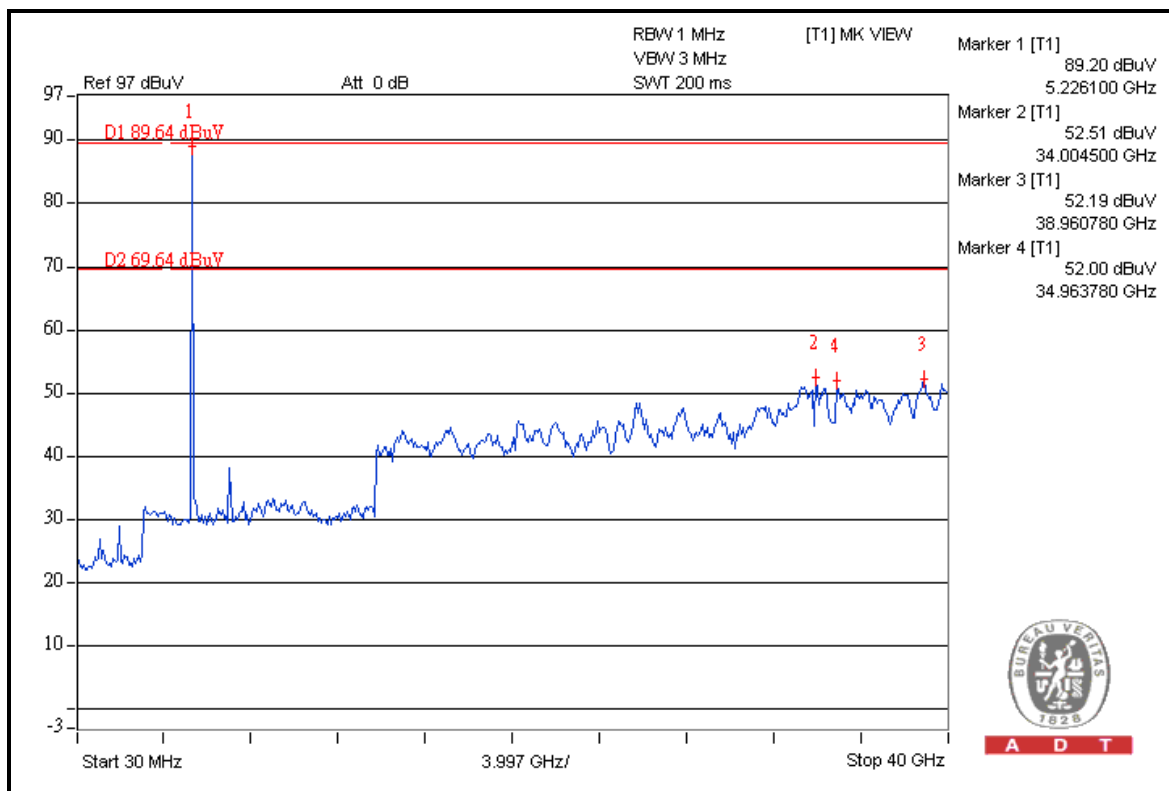





A D T

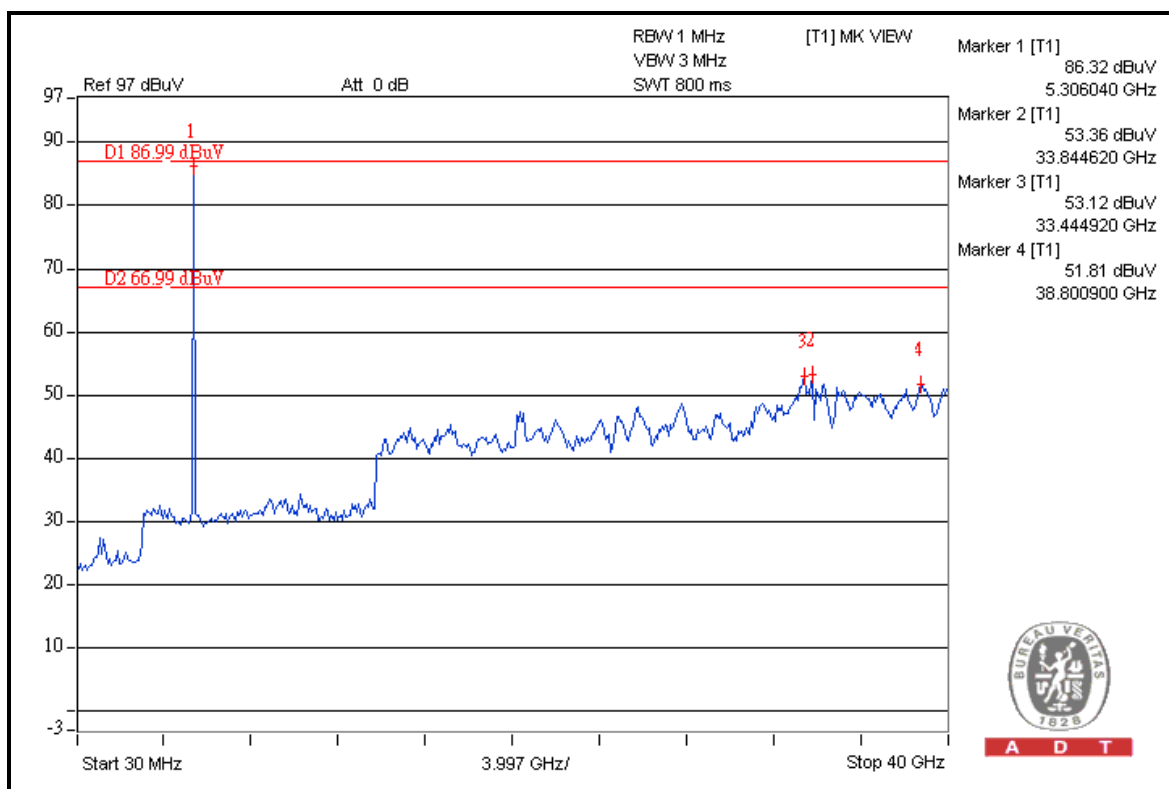
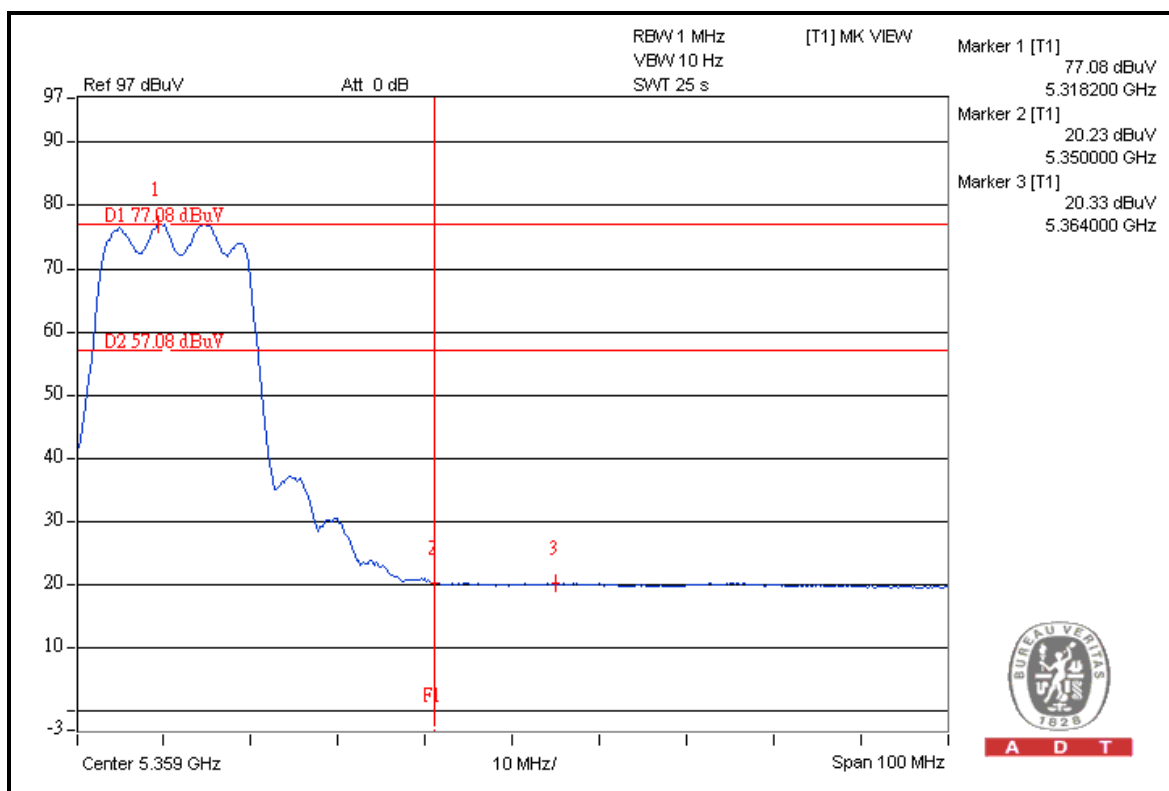

**For Mode C:**

**RESTRICT BAND (4500 ~ 5150 MHz)**

FREQUENCY (MHz)	FUNDAMENTAL EMISSION (dBuV/m)	DELTA (dB)	MAXIMUM FIELD STRENGTH IN RESTRICT BAND (dBuV/m)	LIMIT (dBuV/m)
5260.00 (PK)	121.9	51.9	70.0	74.00
5260.00 (AV)	108.8	56.4	52.4	54.00

**RESTRICT BAND (5350 ~ 5460 MHz)**

FREQUENCY (MHz)	FUNDAMENTAL EMISSION (dBuV/m)	DELTA (dB)	MAXIMUM FIELD STRENGTH IN RESTRICT BAND (dBuV/m)	LIMIT (dBuV/m)
5320.00 (PK)	118.8	50.7	68.1	74.00
5320.00 (AV)	106.1	54.6	51.5	54.00

**NOTE:**

1. Delta = Amplitude between the peak of the fundamental and the peak of the band edge emission. Please check following 3 pages.
2. Maximum field strength in restrict band = Fundamental emission – Delta.



A D T

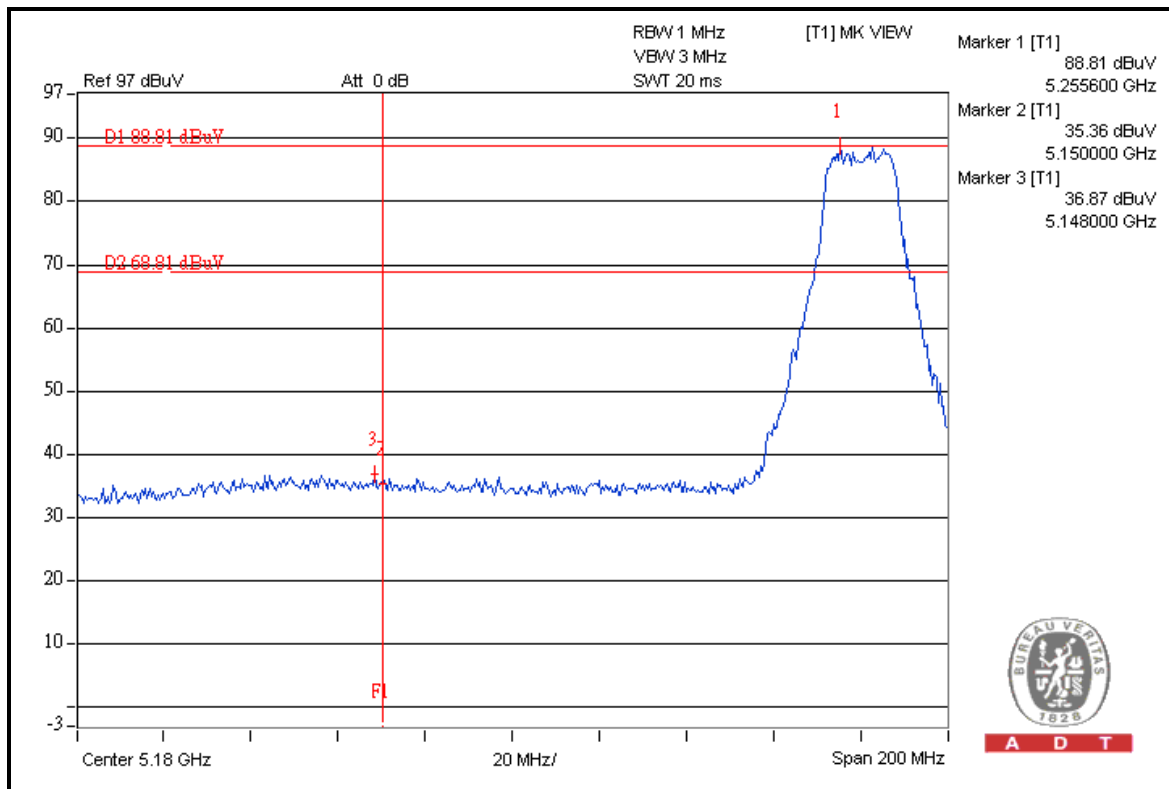

A D T

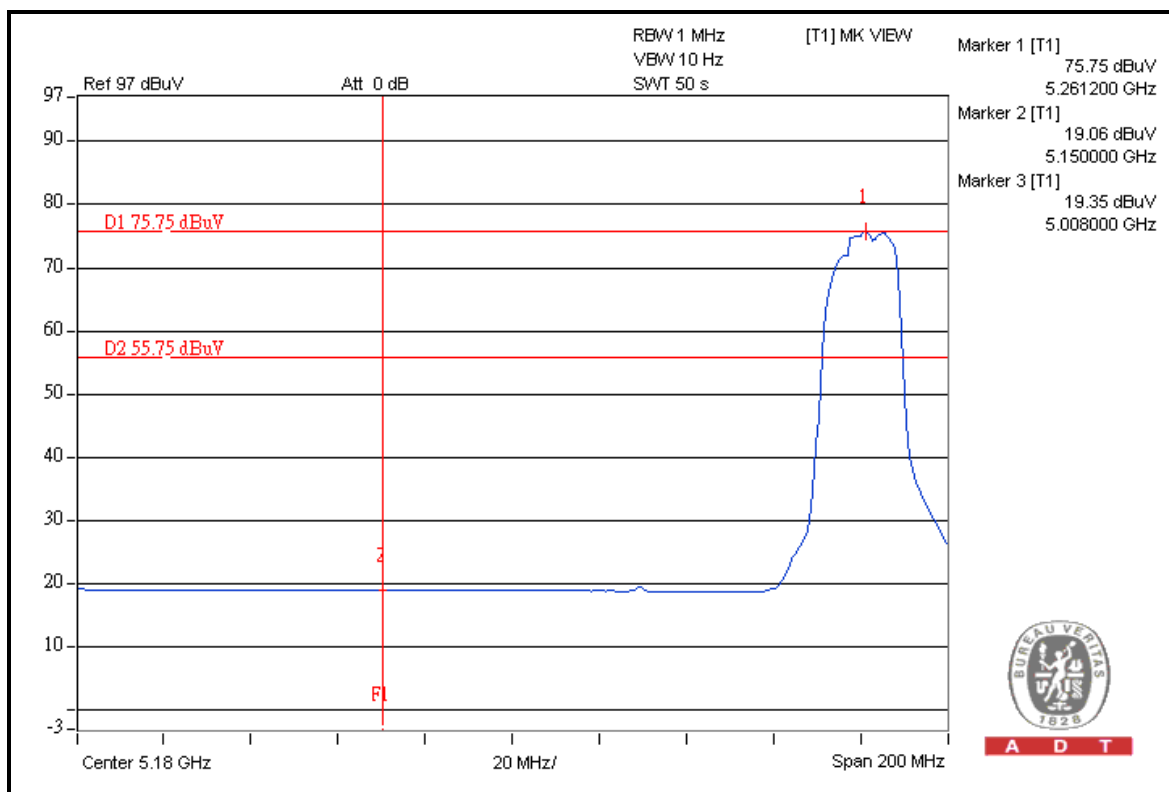

A D T



A D T

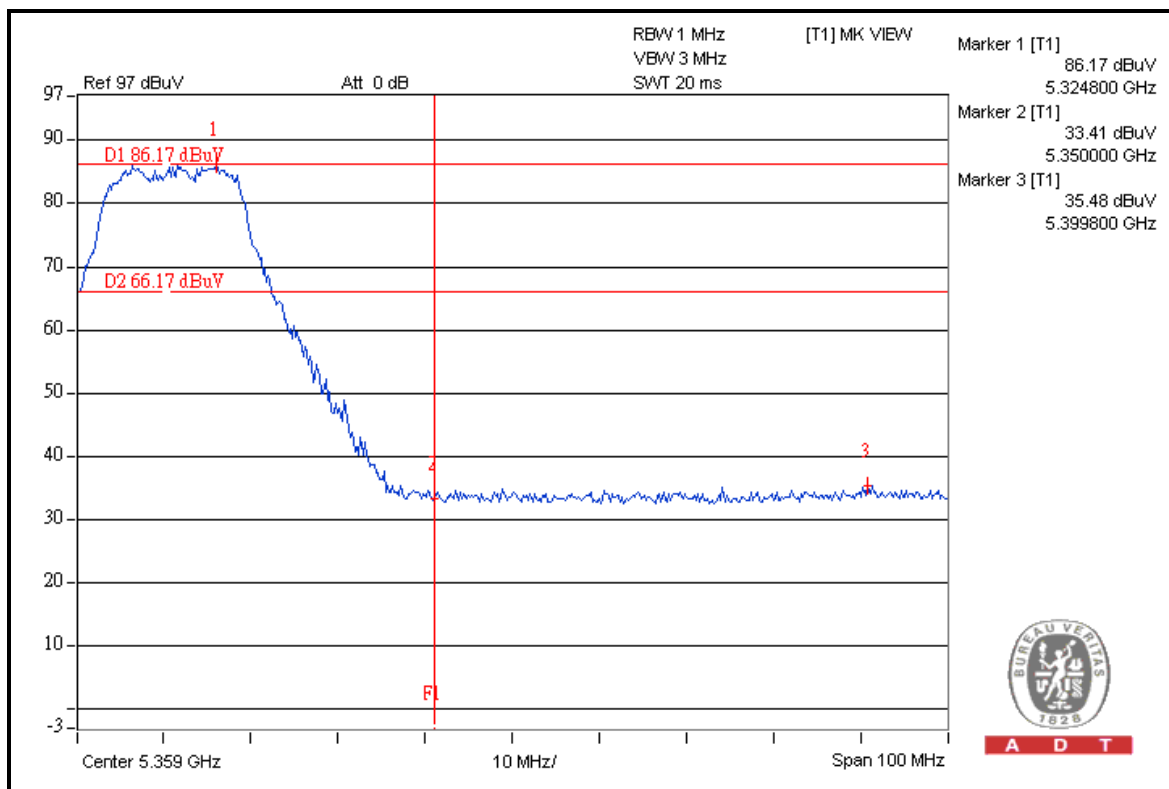
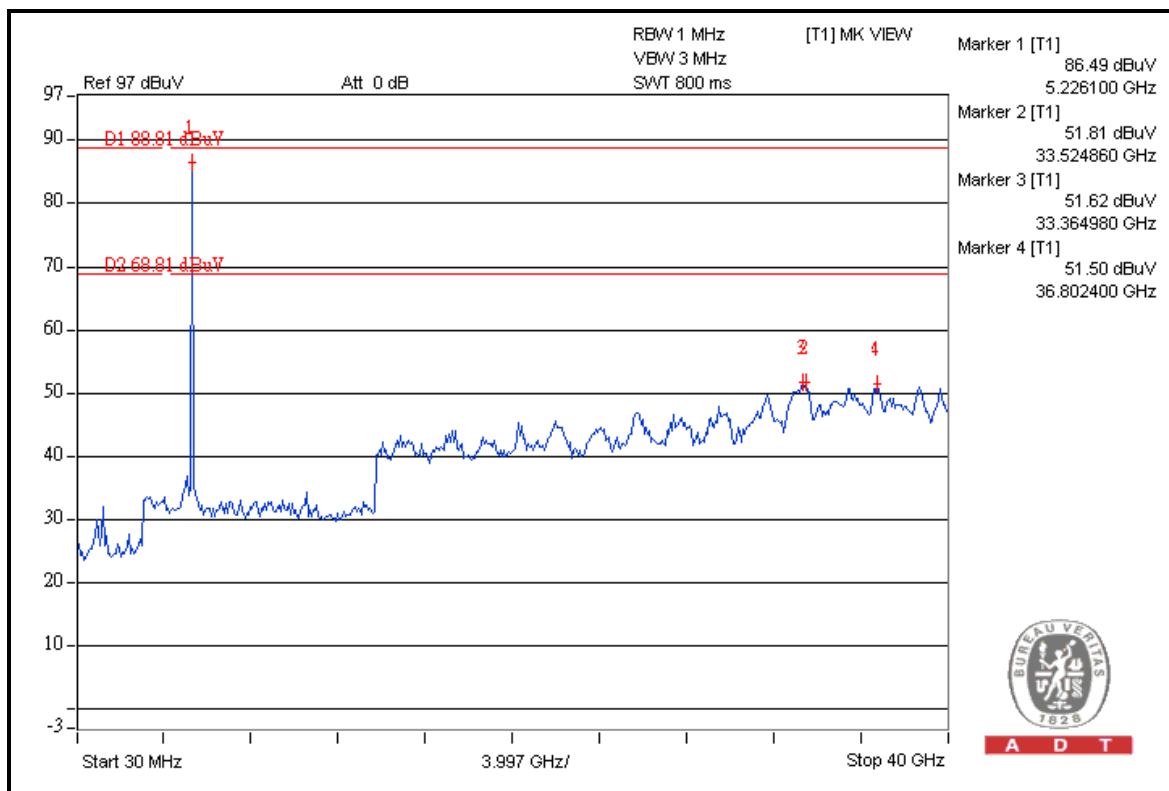



A D T

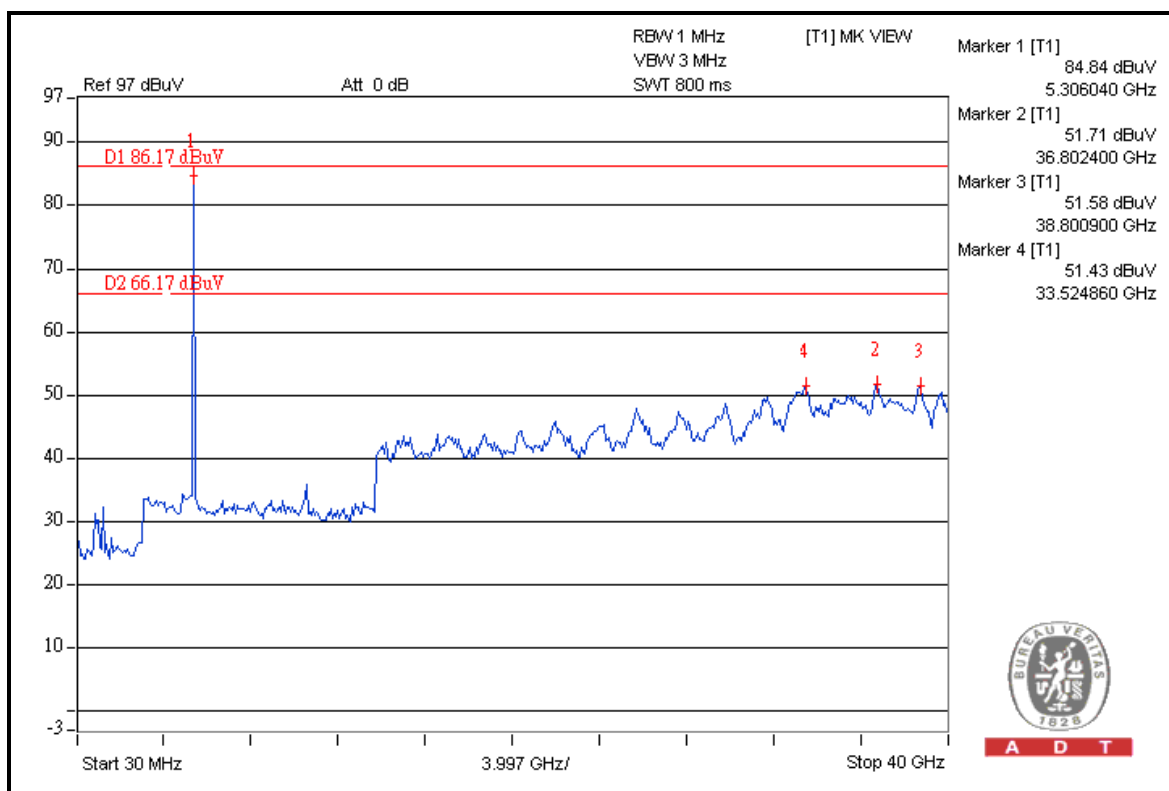
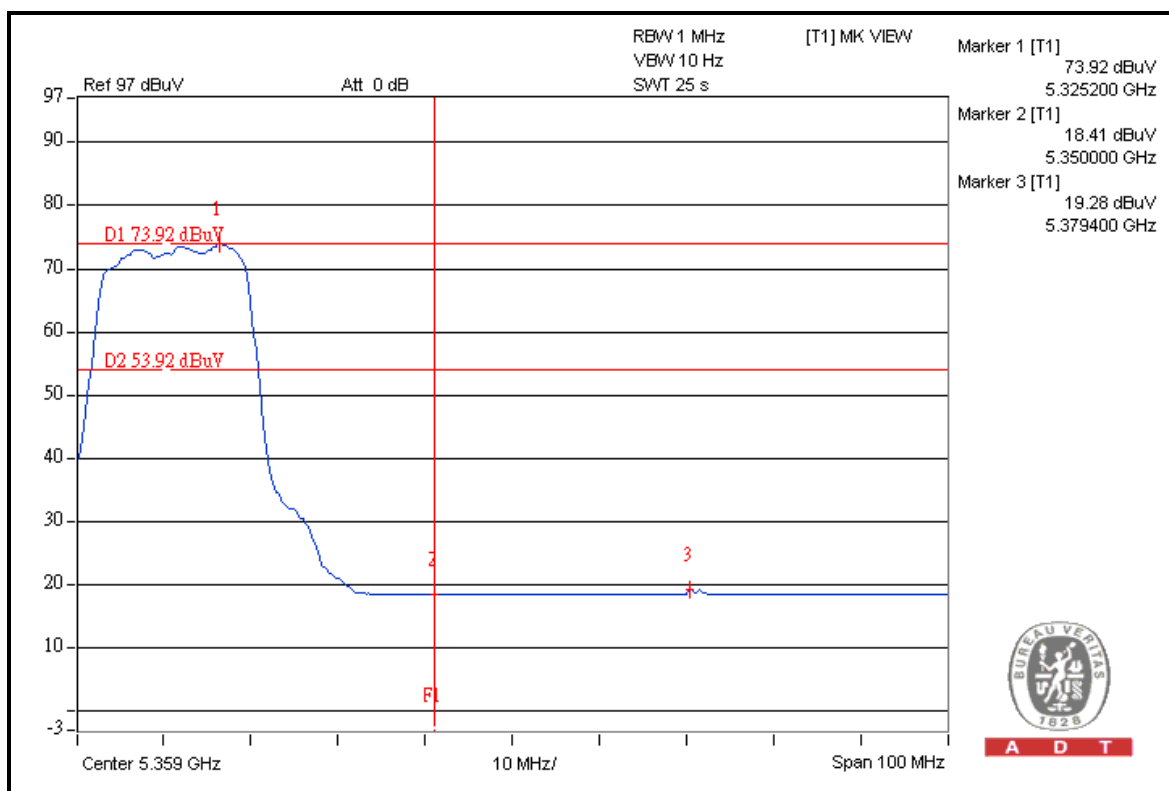



A D T

## FOR 5260-5320MHz BAND: 802.11n (20MHz)

### For Mode A:

#### RESTRICT BAND (4500 ~ 5150 MHz)

FREQUENCY (MHz)	FUNDAMENTAL EMISSION (dBuV/m)	DELTA (dB)	MAXIMUM FIELD STRENGTH IN RESTRICT BAND (dBuV/m)	LIMIT (dBuV/m)
5260.00 (PK)	122.7	50.8	71.9	74.00
5260.00 (AV)	112.0	60.0	52.0	54.00

#### RESTRICT BAND (5350 ~ 5460 MHz)

FREQUENCY (MHz)	FUNDAMENTAL EMISSION (dBuV/m)	DELTA (dB)	MAXIMUM FIELD STRENGTH IN RESTRICT BAND (dBuV/m)	LIMIT (dBuV/m)
5320.00 (PK)	117.6	45.9	71.7	74.00
5320.00 (AV)	107.7	55.7	52.0	54.00

#### NOTE:

1. Delta = Amplitude between the peak of the fundamental and the peak of the band edge emission. Please check following 3 pages.
2. Maximum field strength in restrict band = Fundamental emission – Delta.



A D T

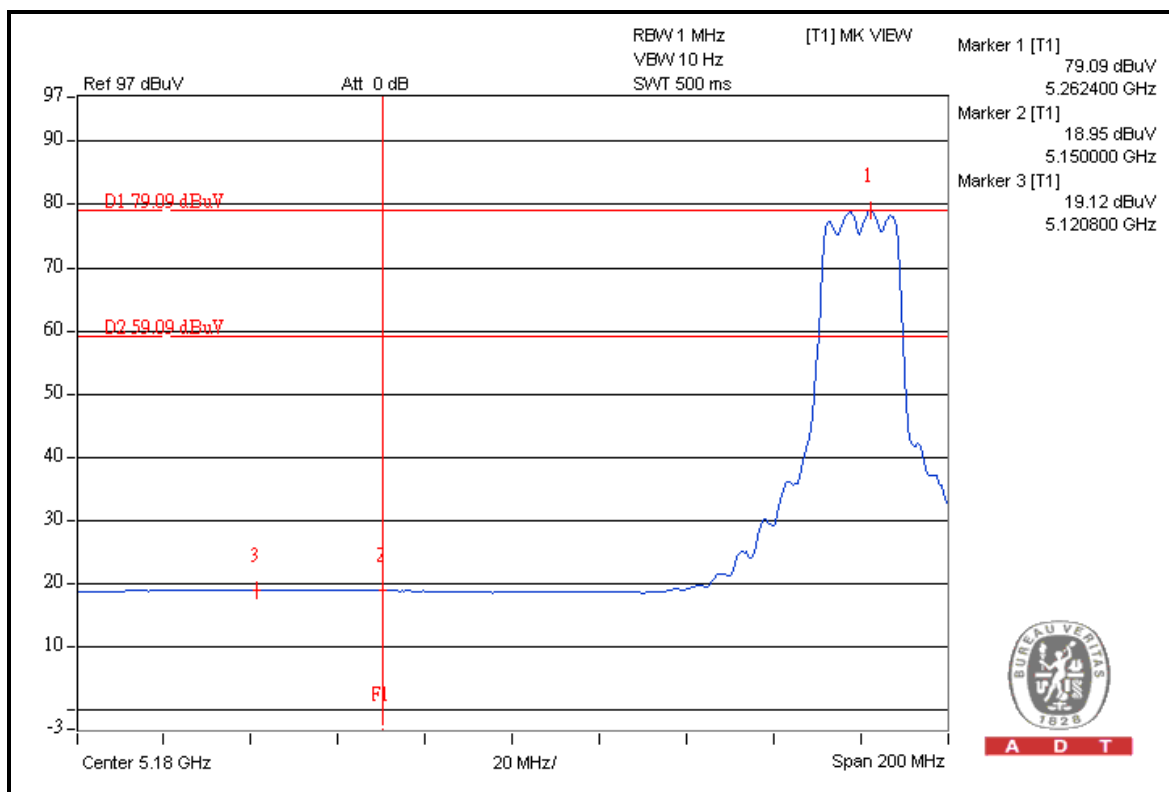
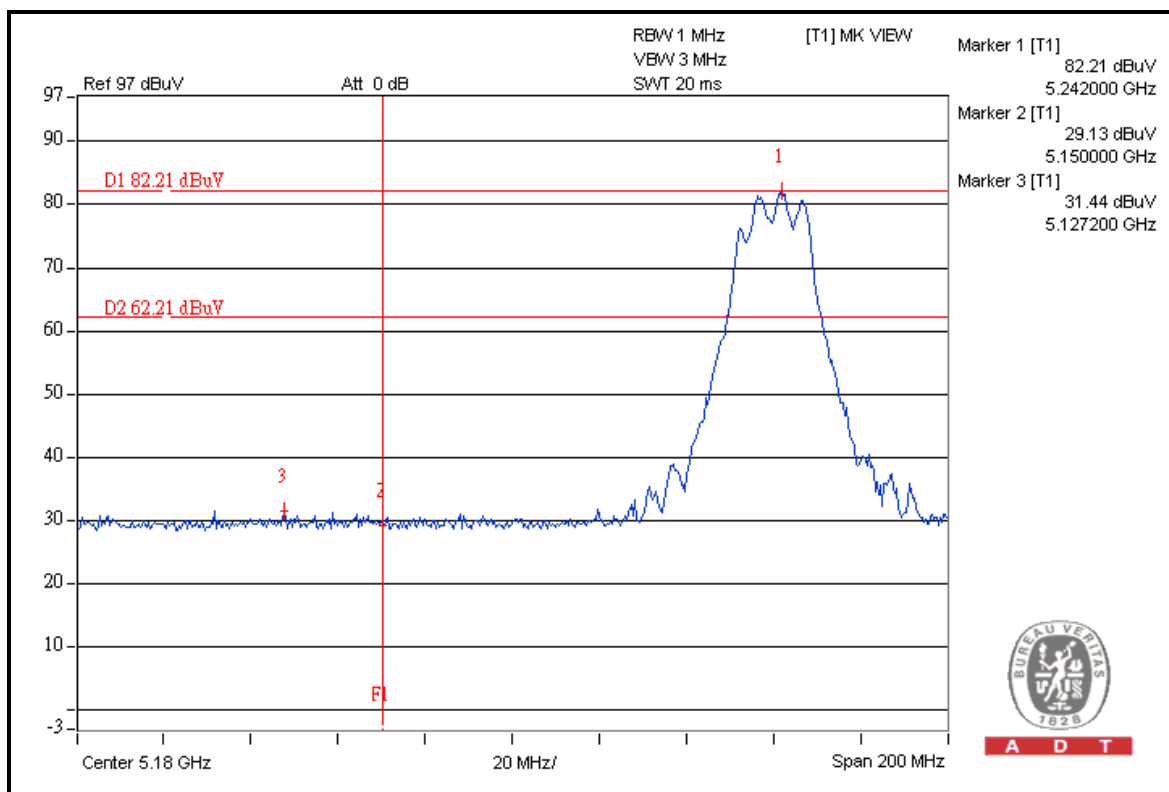



A D T

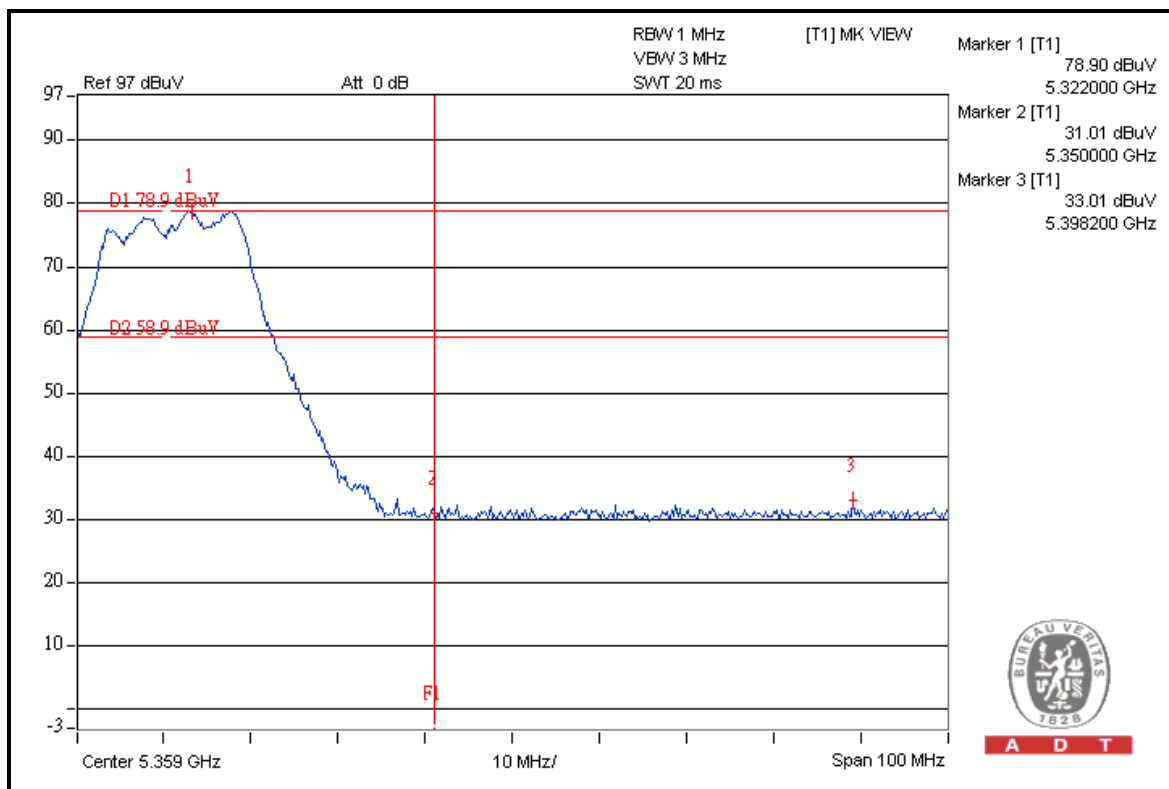
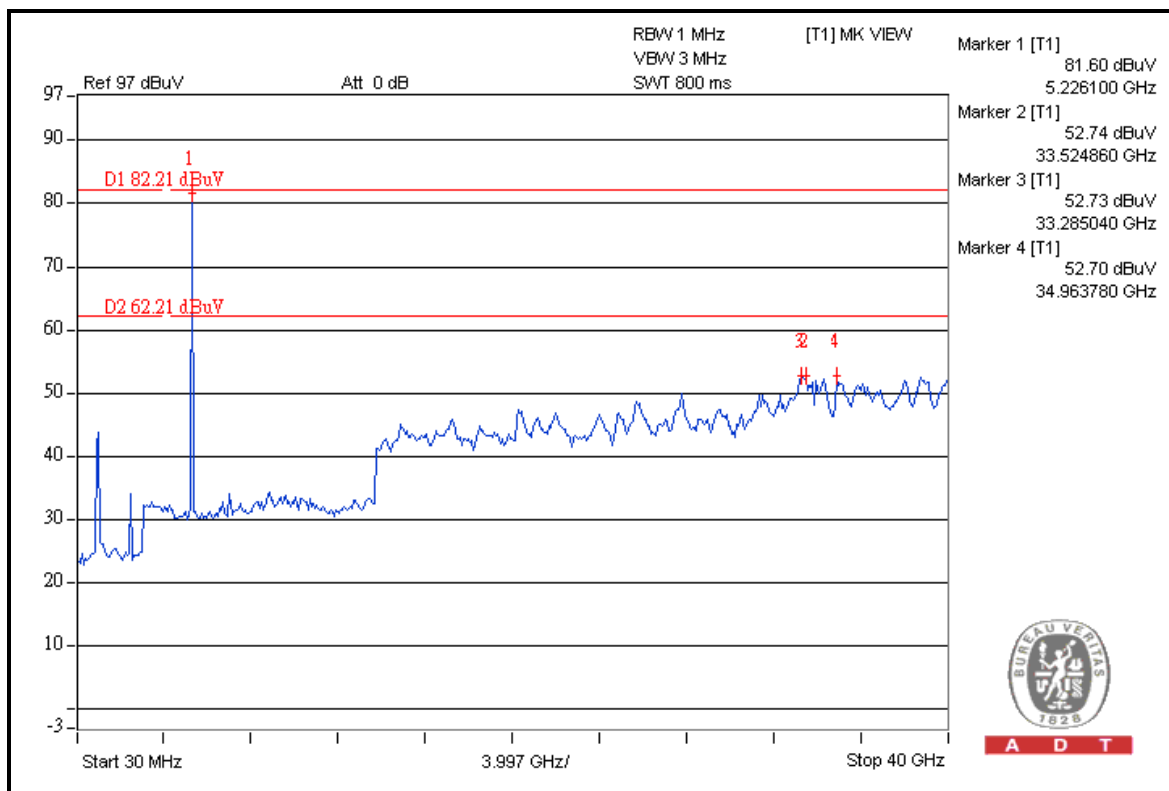





A D T

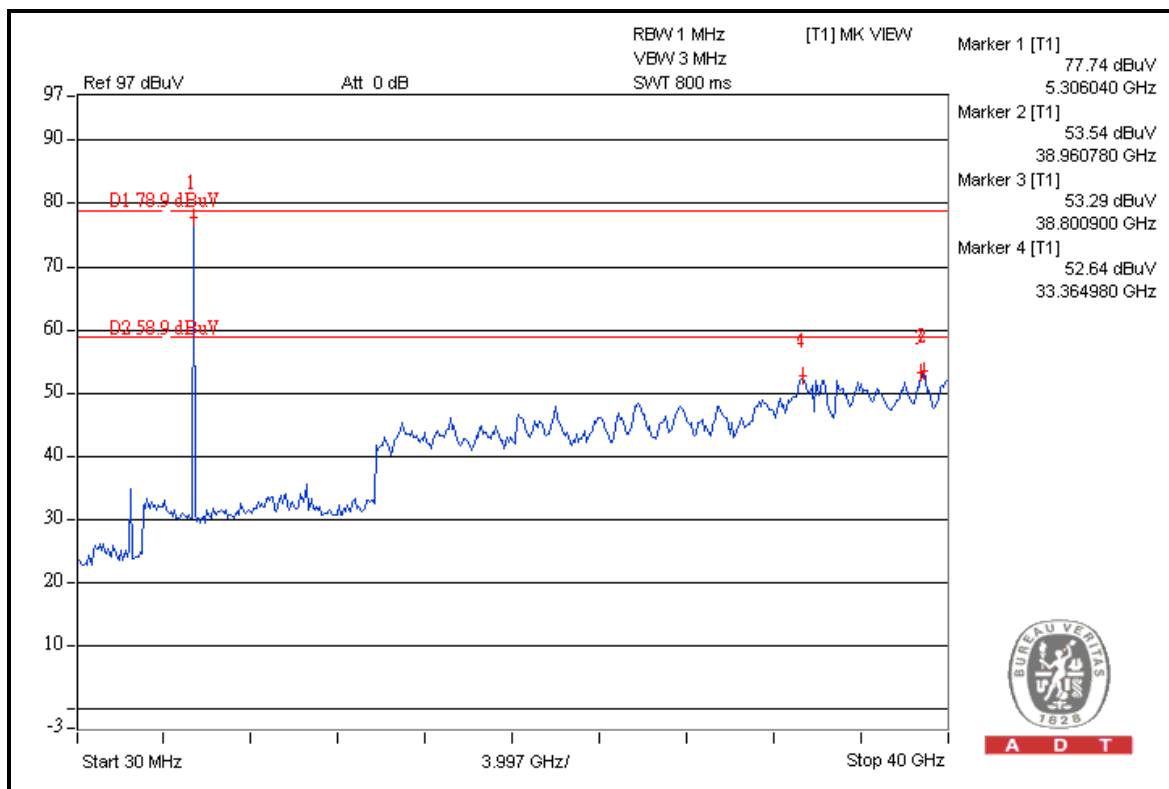
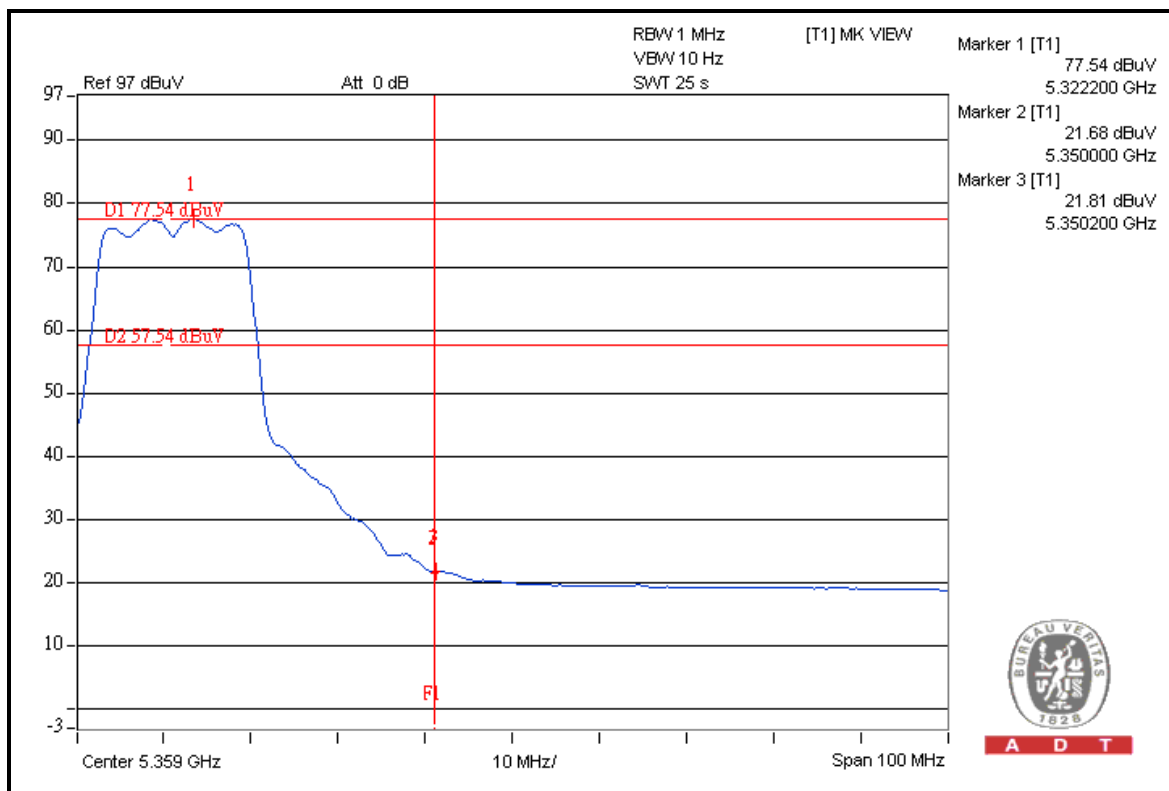



A D T

**For Mode C:**

**RESTRICT BAND (4500 ~ 5150 MHz)**

FREQUENCY (MHz)	FUNDAMENTAL EMISSION (dBuV/m)	DELTA (dB)	MAXIMUM FIELD STRENGTH IN RESTRICT BAND (dBuV/m)	LIMIT (dBuV/m)
5260.00 (PK)	123.0	51.6	71.4	74.00
5260.00 (AV)	109.9	58.0	51.9	54.00

**RESTRICT BAND (5350 ~ 5460 MHz)**

FREQUENCY (MHz)	FUNDAMENTAL EMISSION (dBuV/m)	DELTA (dB)	MAXIMUM FIELD STRENGTH IN RESTRICT BAND (dBuV/m)	LIMIT (dBuV/m)
5320.00 (PK)	119.9	51.5	68.4	74.00
5320.00 (AV)	108.1	58.0	50.1	54.00

**NOTE:**

1. Delta = Amplitude between the peak of the fundamental and the peak of the band edge emission. Please check following 3 pages.
2. Maximum field strength in restrict band = Fundamental emission – Delta.



A D T

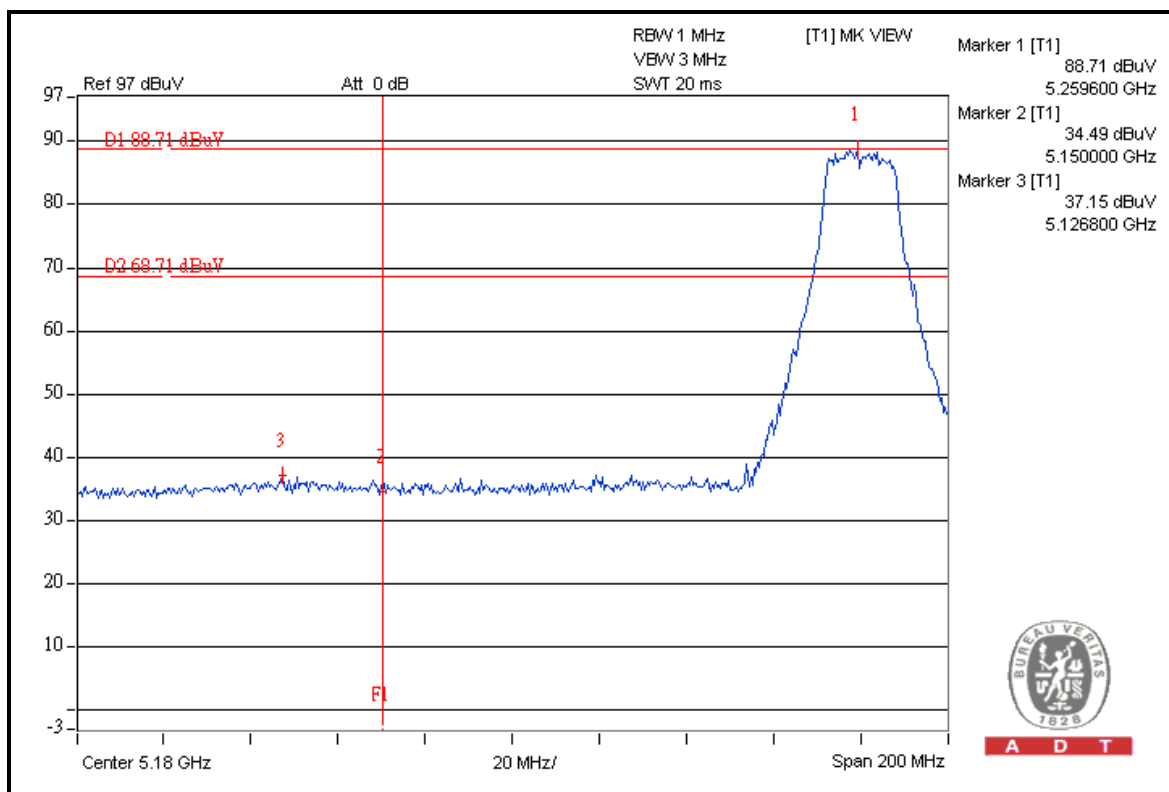

A D T

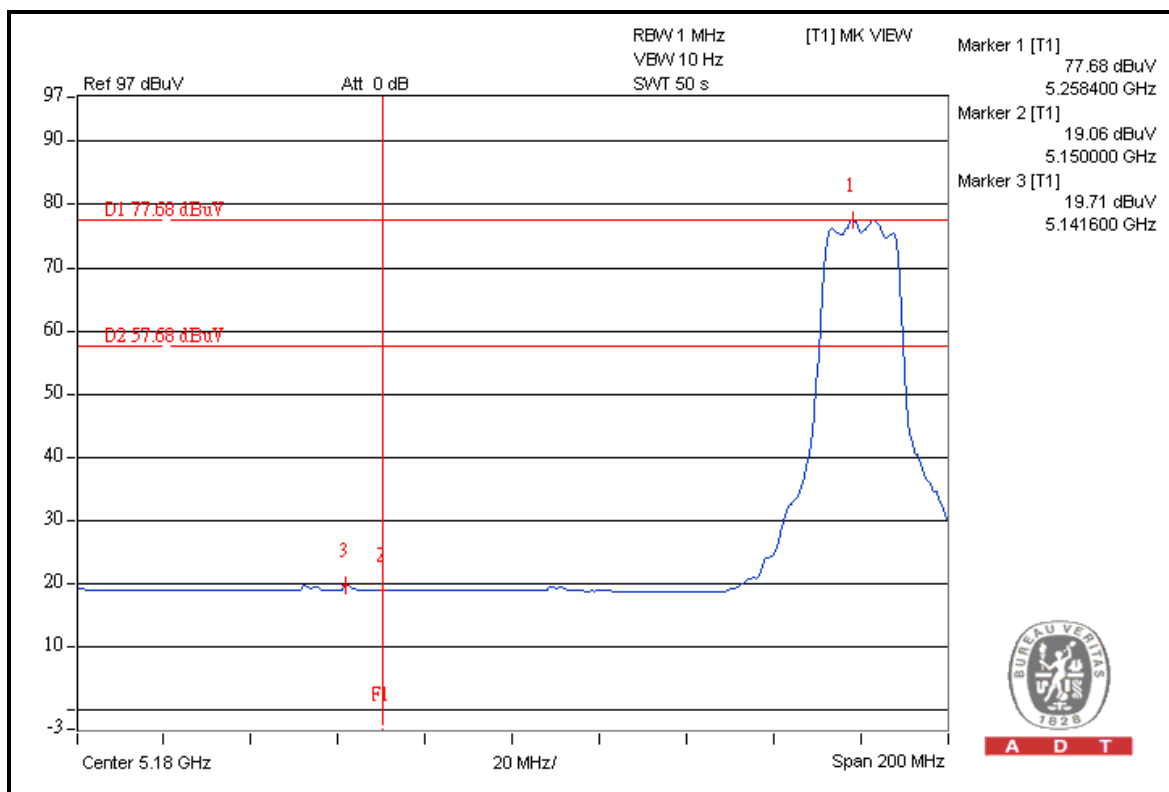

A D T



A D T

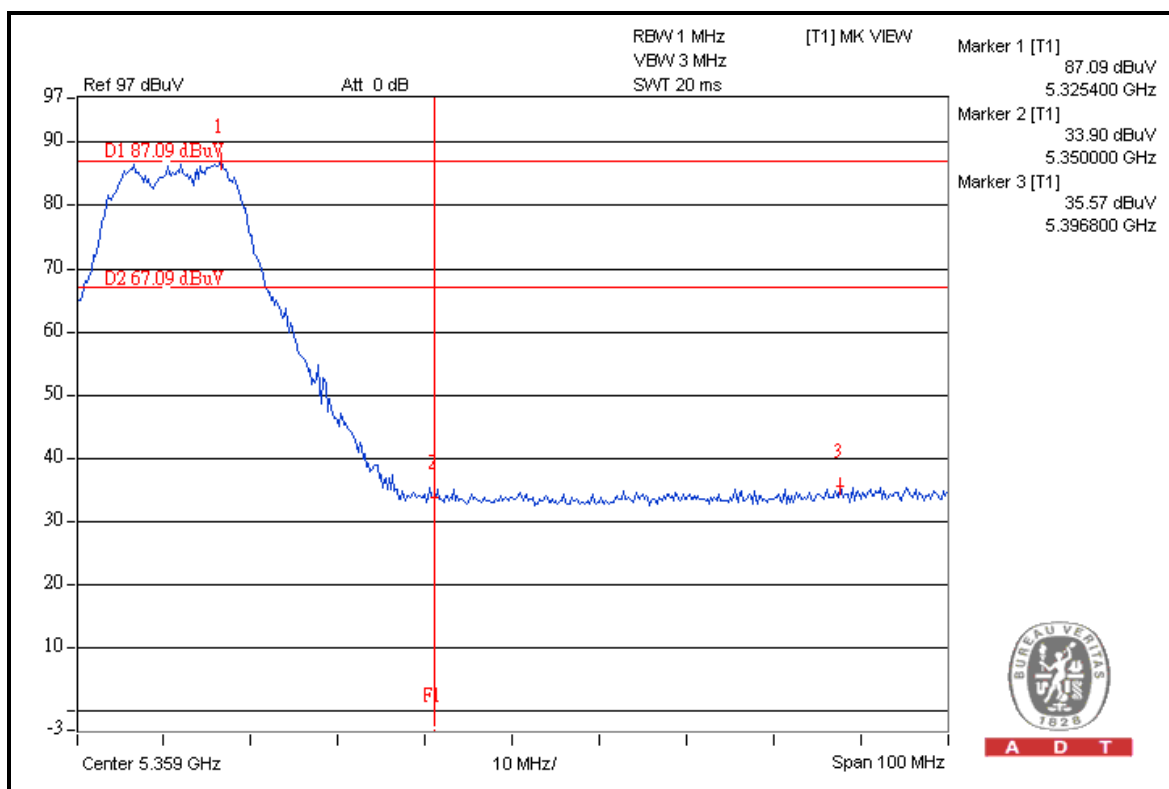
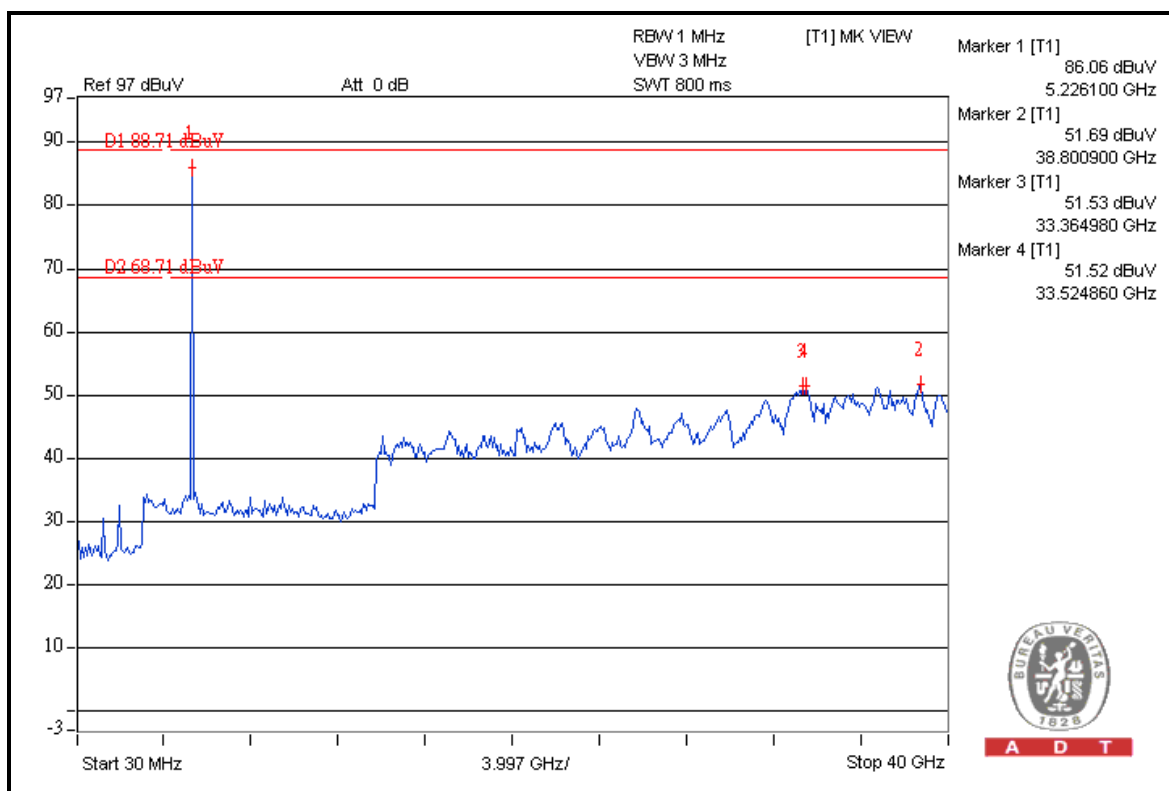



A D T

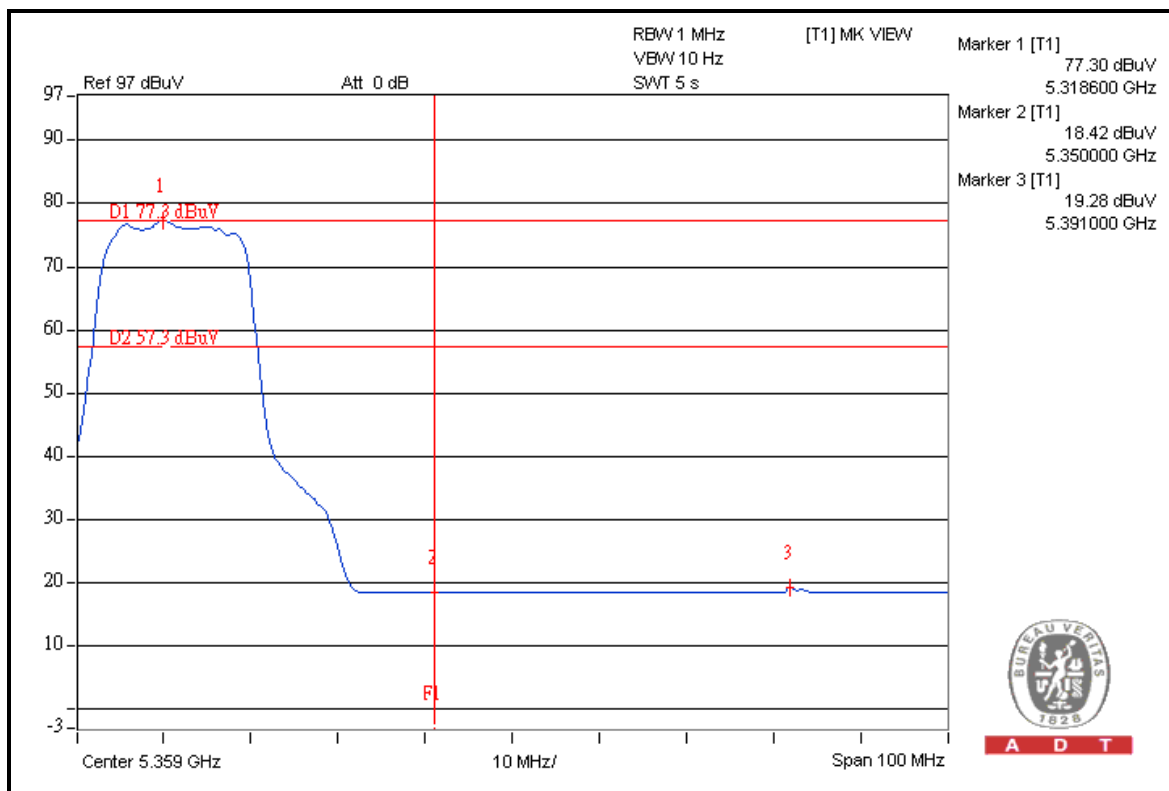

A D T

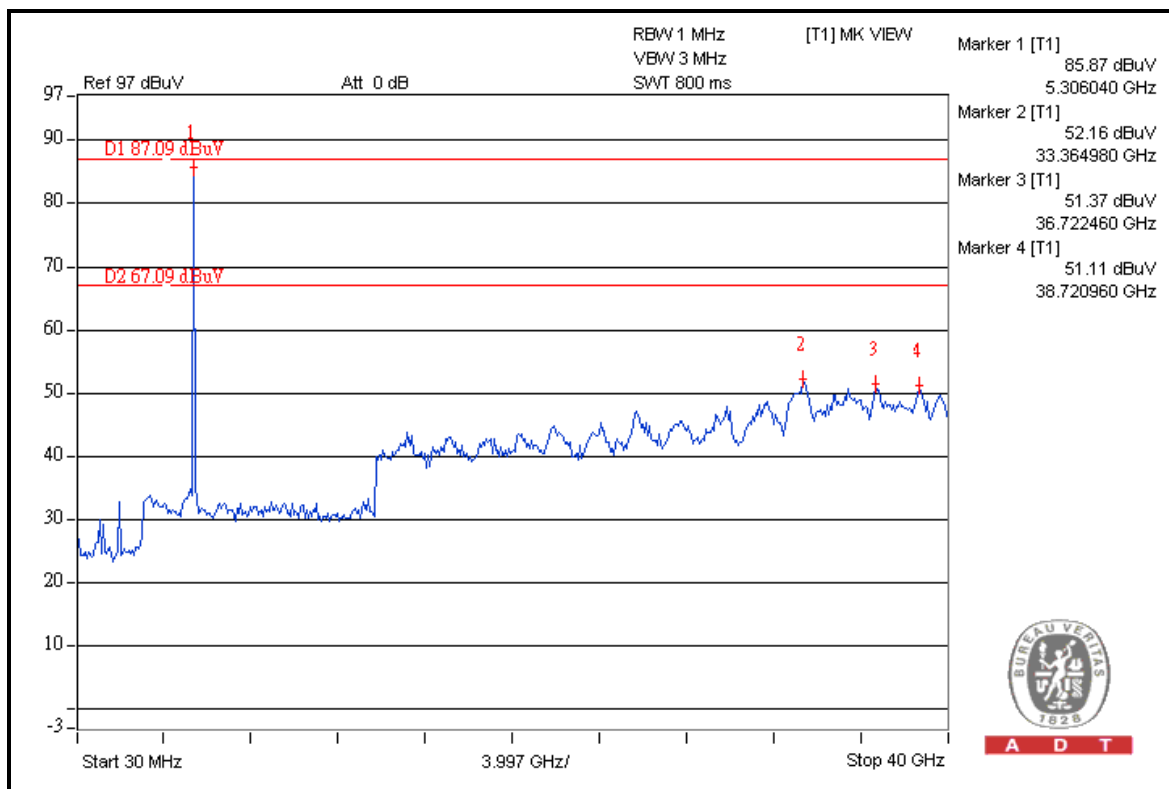

A D T



A D T

## FOR 5270-5310MHz BAND: 802.11n (40MHz)

### For Mode A:

#### RESTRICT BAND (4500 ~ 5150 MHz)

FREQUENCY (MHz)	FUNDAMENTAL EMISSION (dBuV/m)	DELTA (dB)	MAXIMUM FIELD STRENGTH IN RESTRICT BAND (dBuV/m)	LIMIT (dBuV/m)
5270.00 (PK)	118.3	52.4	65.9	74.00
5270.00 (AV)	107.0	54.2	52.8	54.00

#### RESTRICT BAND (5350 ~ 5460 MHz)

FREQUENCY (MHz)	FUNDAMENTAL EMISSION (dBuV/m)	DELTA (dB)	MAXIMUM FIELD STRENGTH IN RESTRICT BAND (dBuV/m)	LIMIT (dBuV/m)
5310.00 (PK)	110.6	38.3	72.3	74.00
5310.00 (AV)	100.7	47.1	53.6	54.00

#### NOTE:

1. Delta = Amplitude between the peak of the fundamental and the peak of the band edge emission. Please check following 3 pages.
2. Maximum field strength in restrict band = Fundamental emission – Delta.



A D T

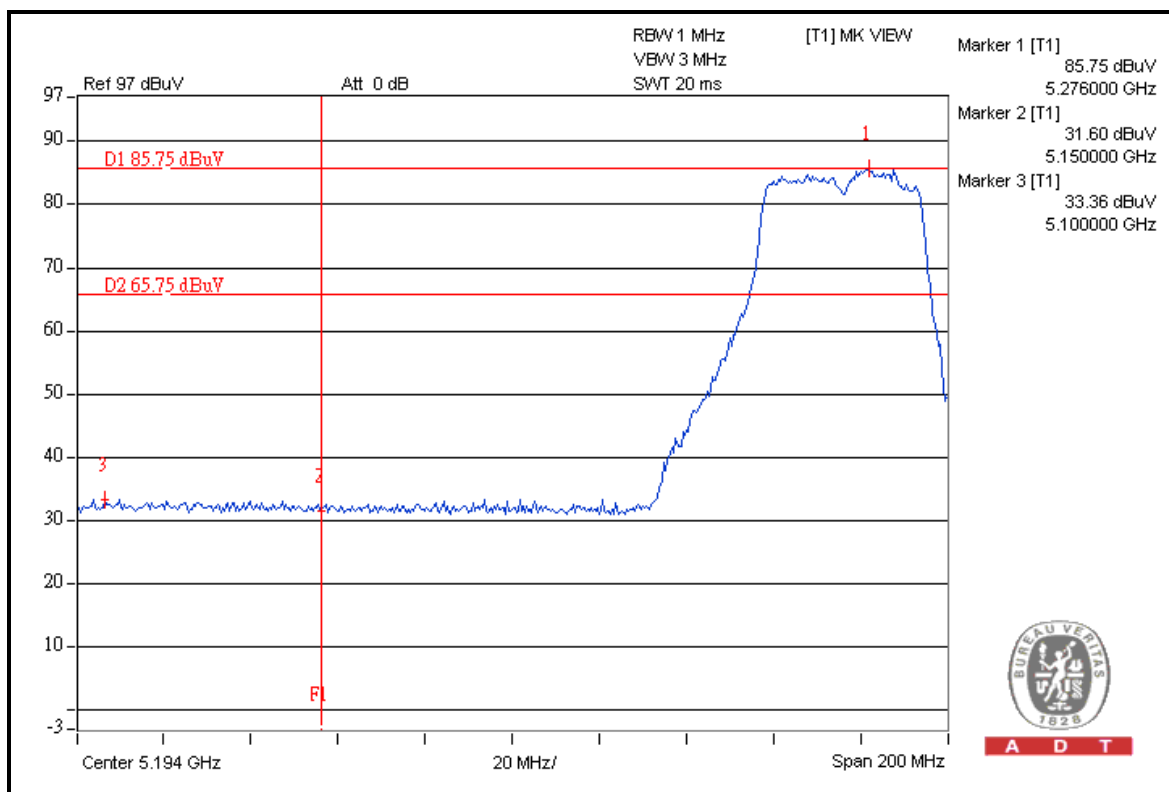

A D T

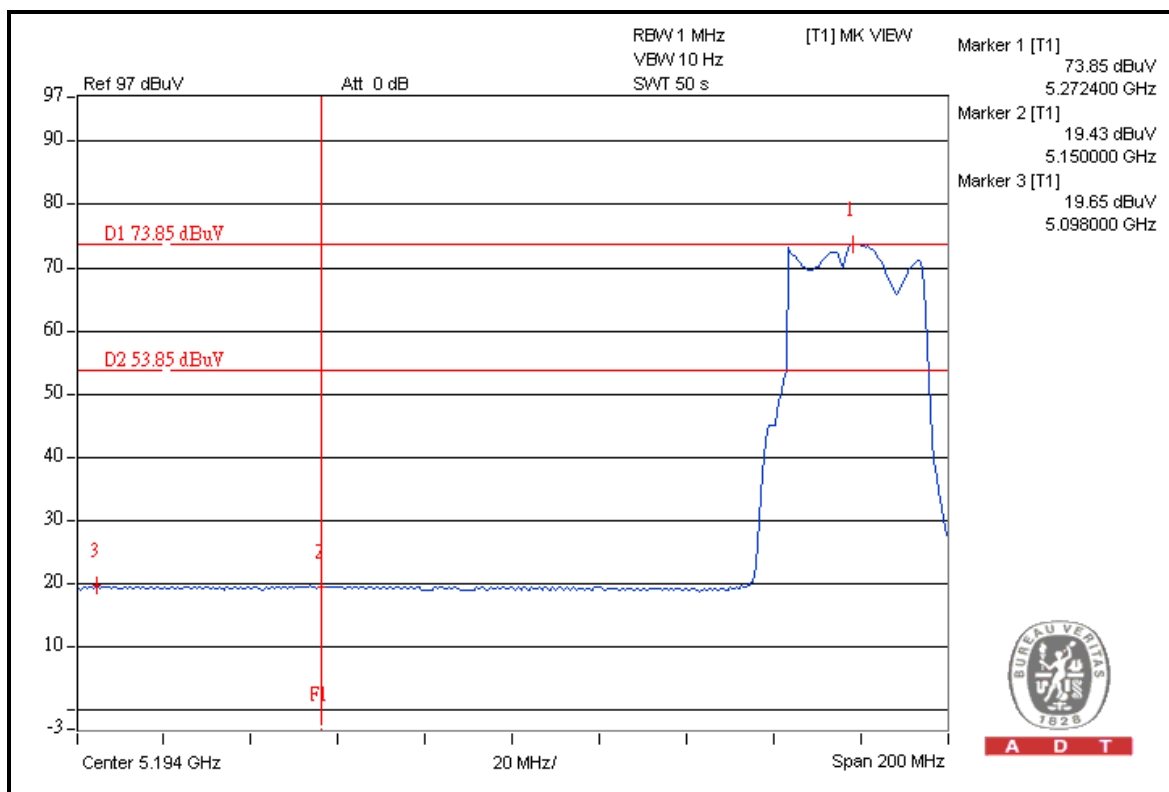

A D T



A D T

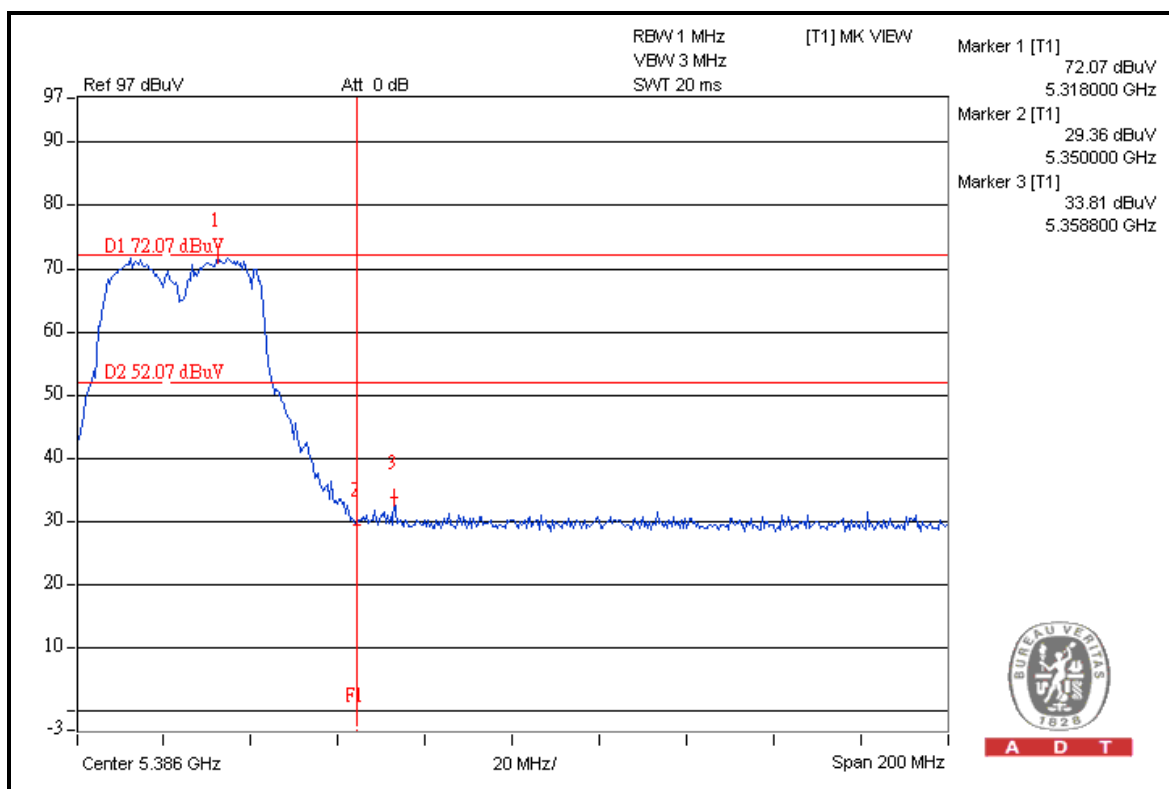
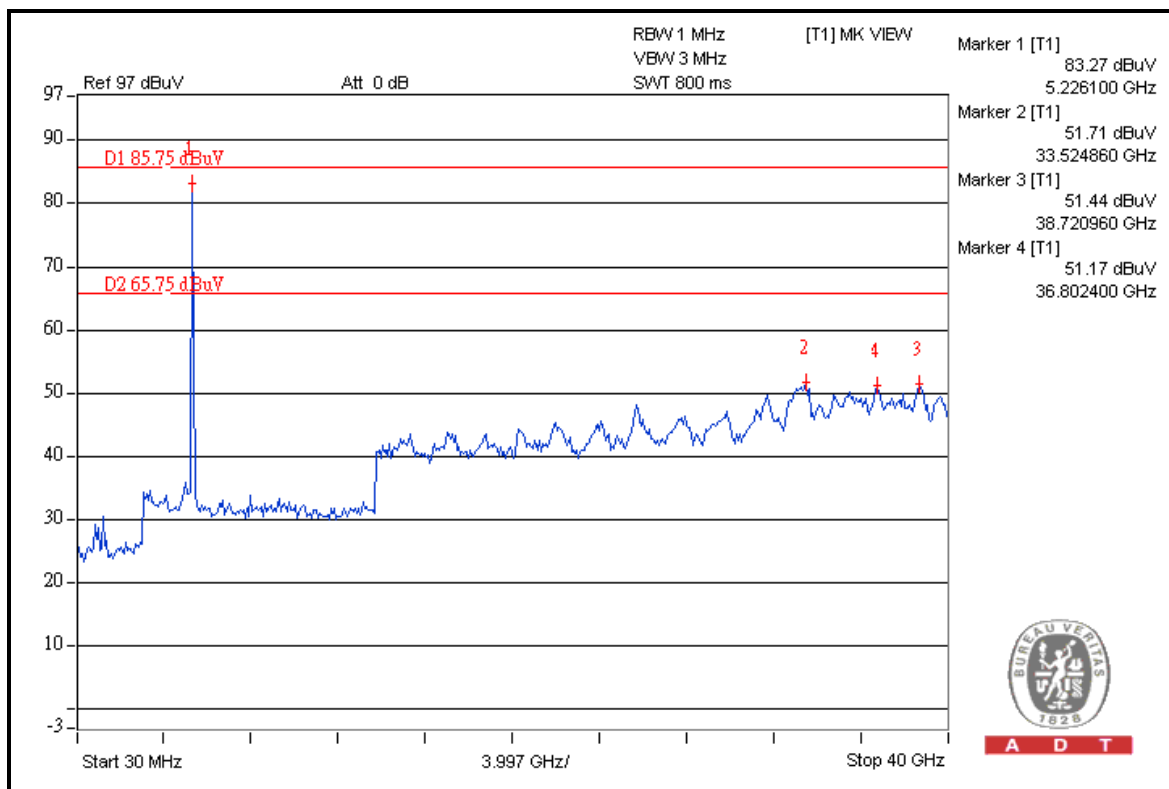





A D T

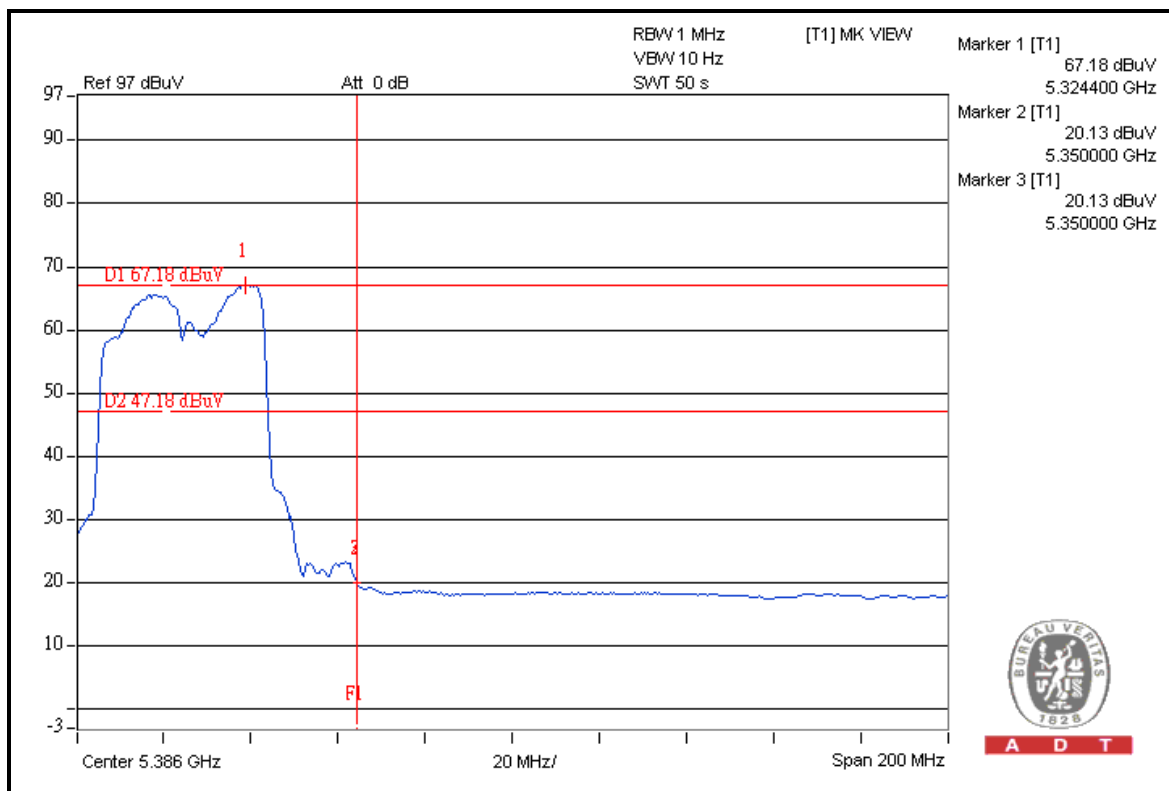

A D T

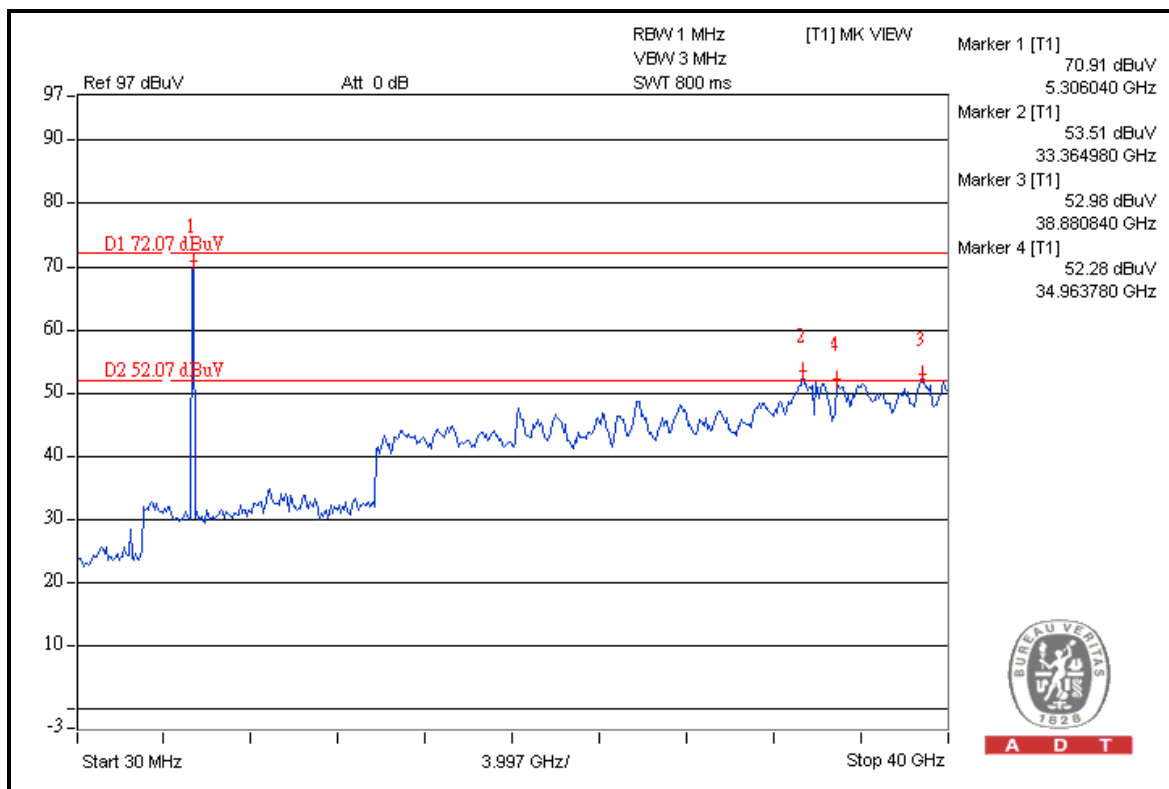

A D T

**For Mode C:**

**RESTRICT BAND (4500 ~ 5150 MHz)**

FREQUENCY (MHz)	FUNDAMENTAL EMISSION (dBuV/m)	DELTA (dB)	MAXIMUM FIELD STRENGTH IN RESTRICT BAND (dBuV/m)	LIMIT (dBuV/m)
5270.00 (PK)	119.0	49.2	69.8	74.00
5270.00 (AV)	108.6	55.9	52.7	54.00

**RESTRICT BAND (5350 ~ 5460 MHz)**

FREQUENCY (MHz)	FUNDAMENTAL EMISSION (dBuV/m)	DELTA (dB)	MAXIMUM FIELD STRENGTH IN RESTRICT BAND (dBuV/m)	LIMIT (dBuV/m)
5310.00 (PK)	115.7	53.8	61.9	74.00
5310.00 (AV)	104.7	57.5	47.2	54.00

**NOTE:**

1. Delta = Amplitude between the peak of the fundamental and the peak of the band edge emission. Please check following 3 pages.
2. Maximum field strength in restrict band = Fundamental emission – Delta.



A D T

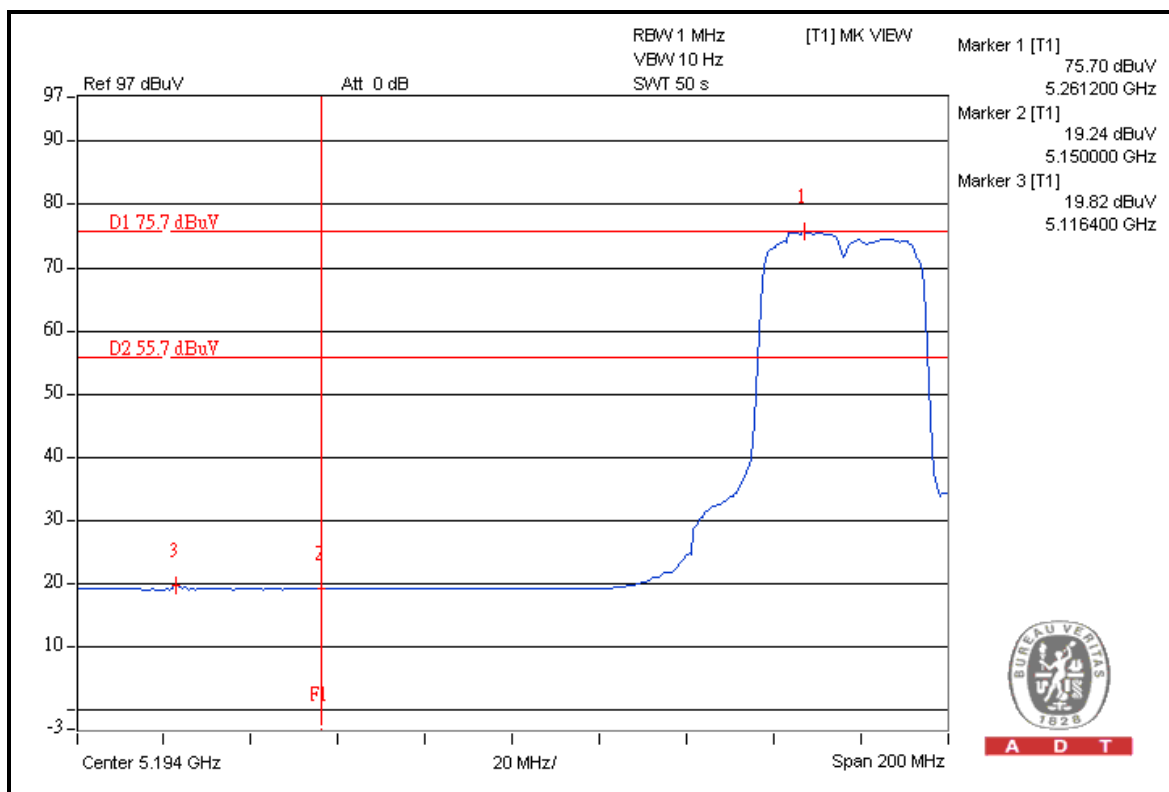
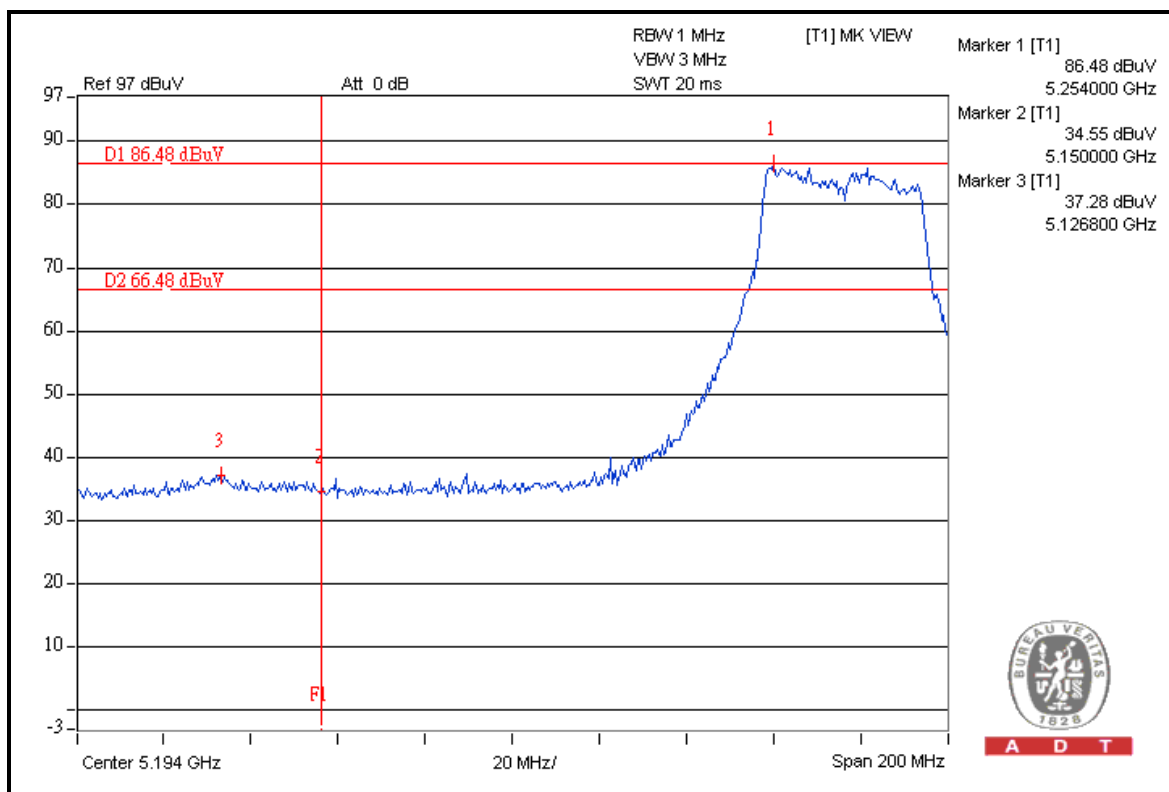



A D T

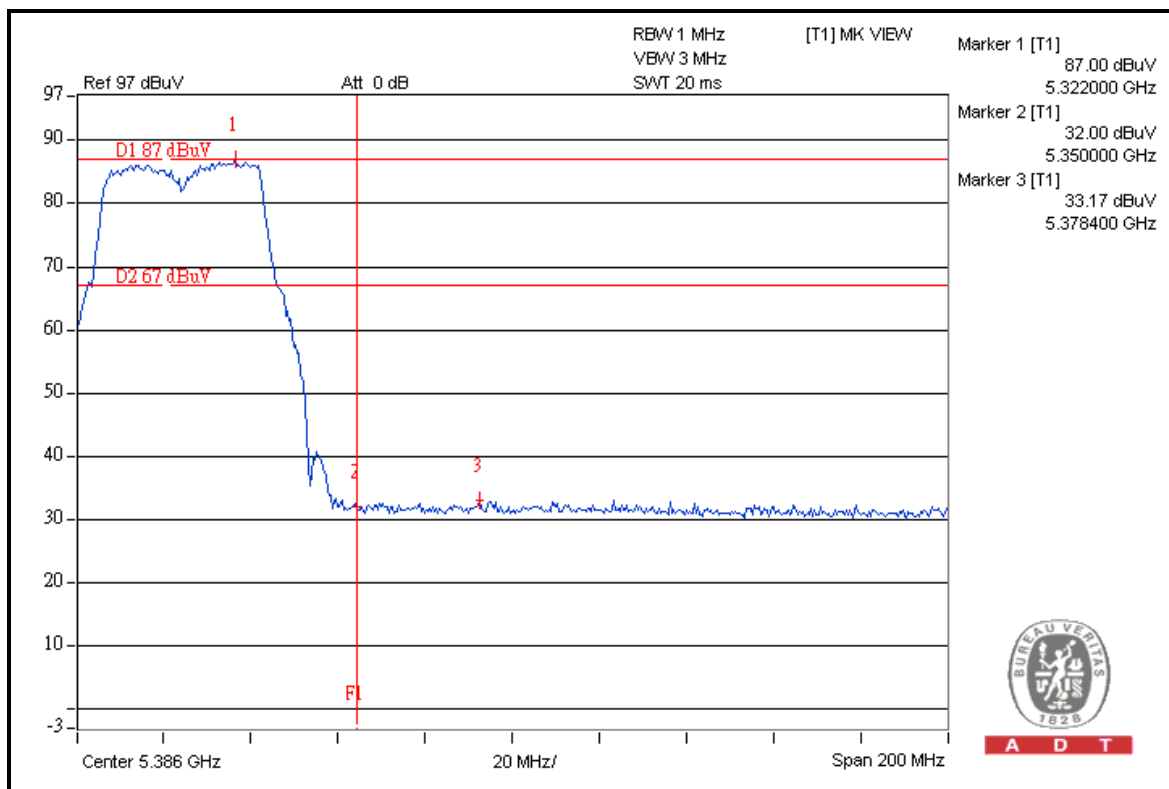
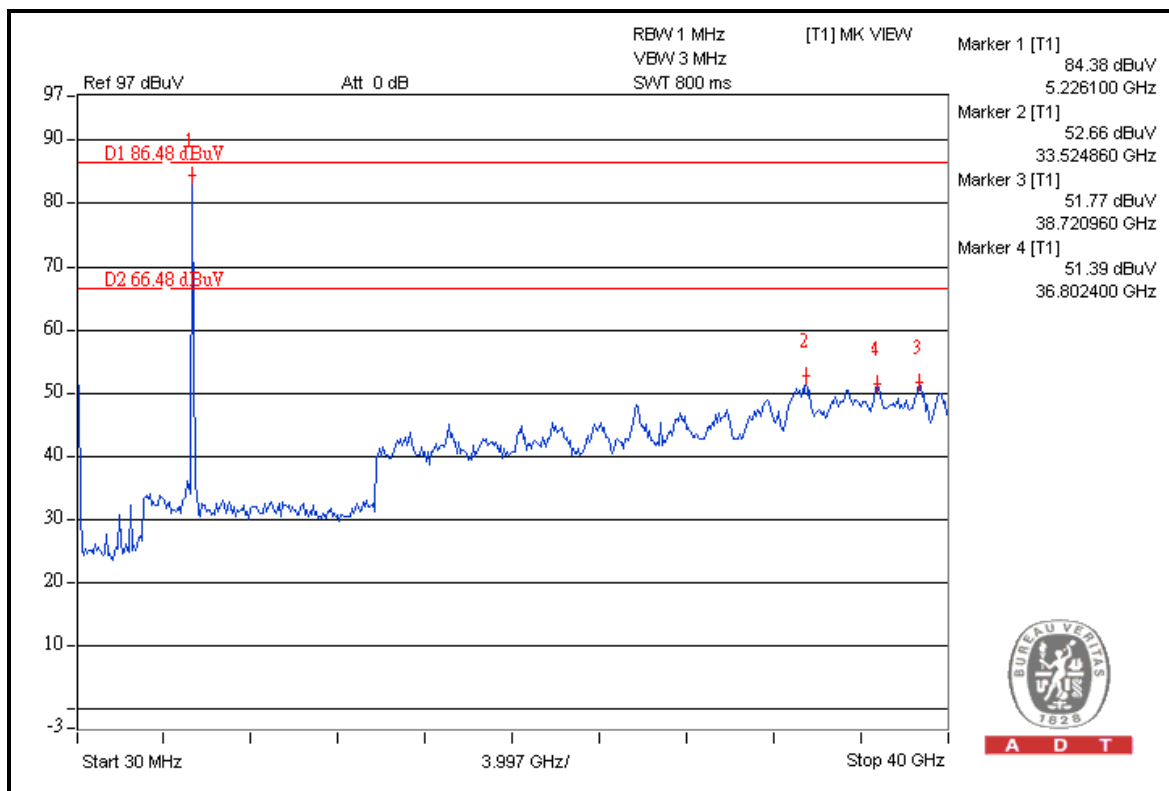



A D T

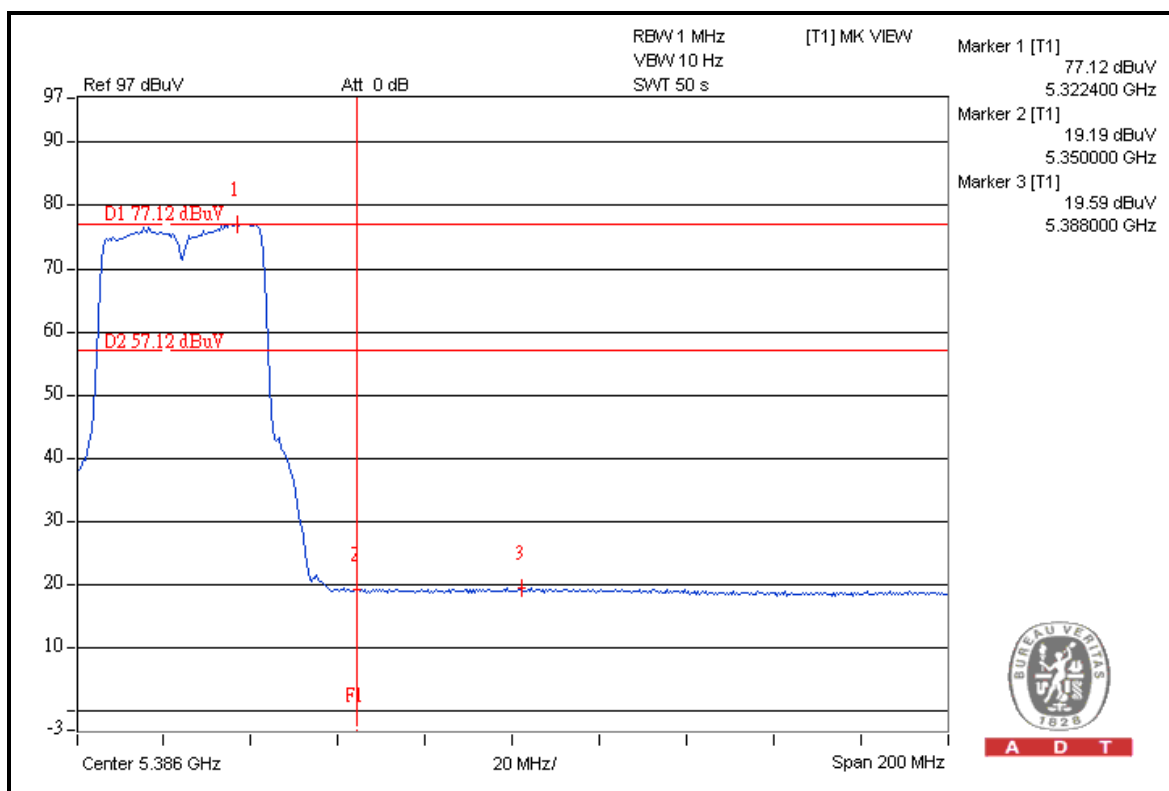

A D T

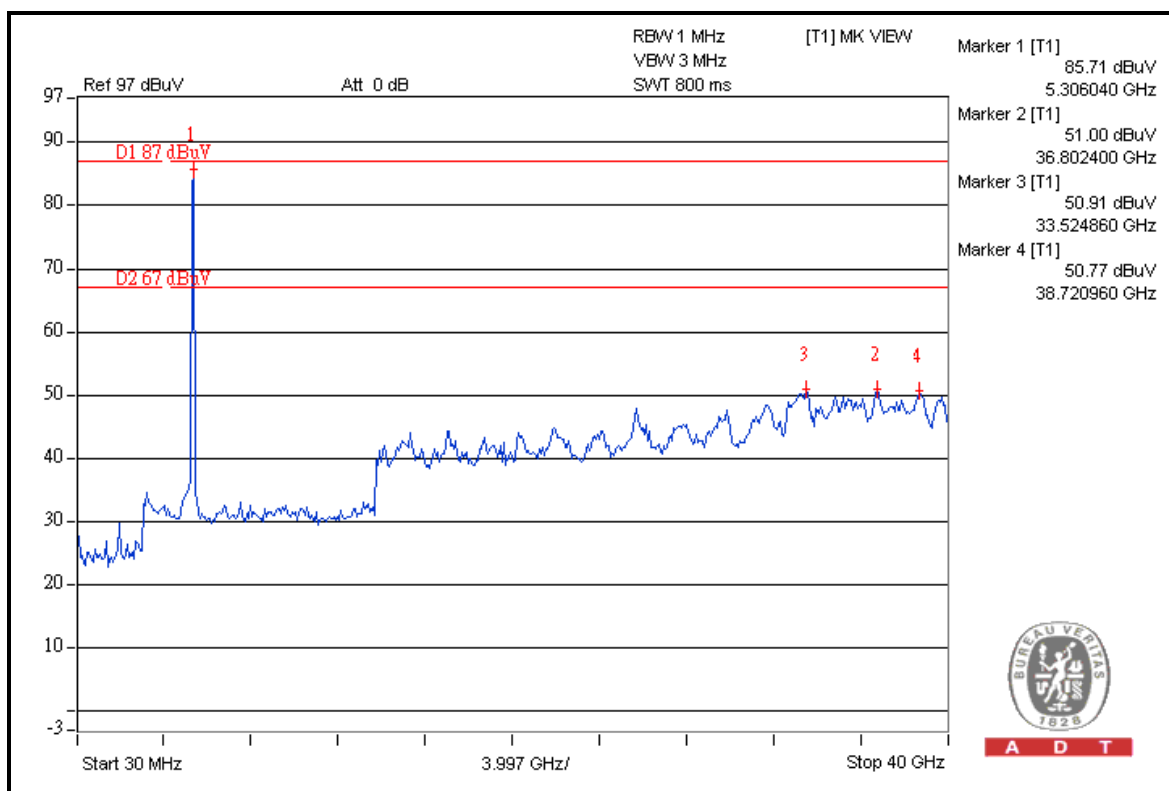

A D T



A D T

## FOR 5500-5700MHz BAND: 802.11a

For Mode A:

### 5500MHz

#### RESTRICT BAND (5350 ~ 5460 MHz)

FREQUENCY (MHz)	FUNDAMENTAL EMISSION (dBuV/m)	DELTA (dB)	MAXIMUM FIELD STRENGTH IN RESTRICT BAND (dBuV/m)	LIMIT (dBuV/m)
5500.00 (PK)	117.0	51.6	65.4	74.00
5500.00 (AV)	105.0	54.6	50.4	54.00

#### FREQUENCY BAND (5460 ~ 5470 MHz)

FREQUENCY (MHz)	FUNDAMENTAL EMISSION (dBuV/m)	DELTA (dB)	MAXIMUM FIELD STRENGTH (dBuV/m)	LIMIT (dBuV/m)
5500.00 (PK)	117.0	48.7	68.3	88.30

### 5700MHz

#### ABOVE 5725 MHz

FREQUENCY (MHz)	FUNDAMENTAL EMISSION (dBuV/m)	DELTA (dB)	MAXIMUM FIELD STRENGTH (dBuV/m)	LIMIT (dBuV/m)
5700.00 (PK)	116.1	50.3	65.8	88.30

#### NOTE:

1. Delta = Amplitude between the peak of the fundamental and the peak of the band edge emission. Please check following 3 pages.
2. Maximum field strength in restrict band = Fundamental emission – Delta.



A D T

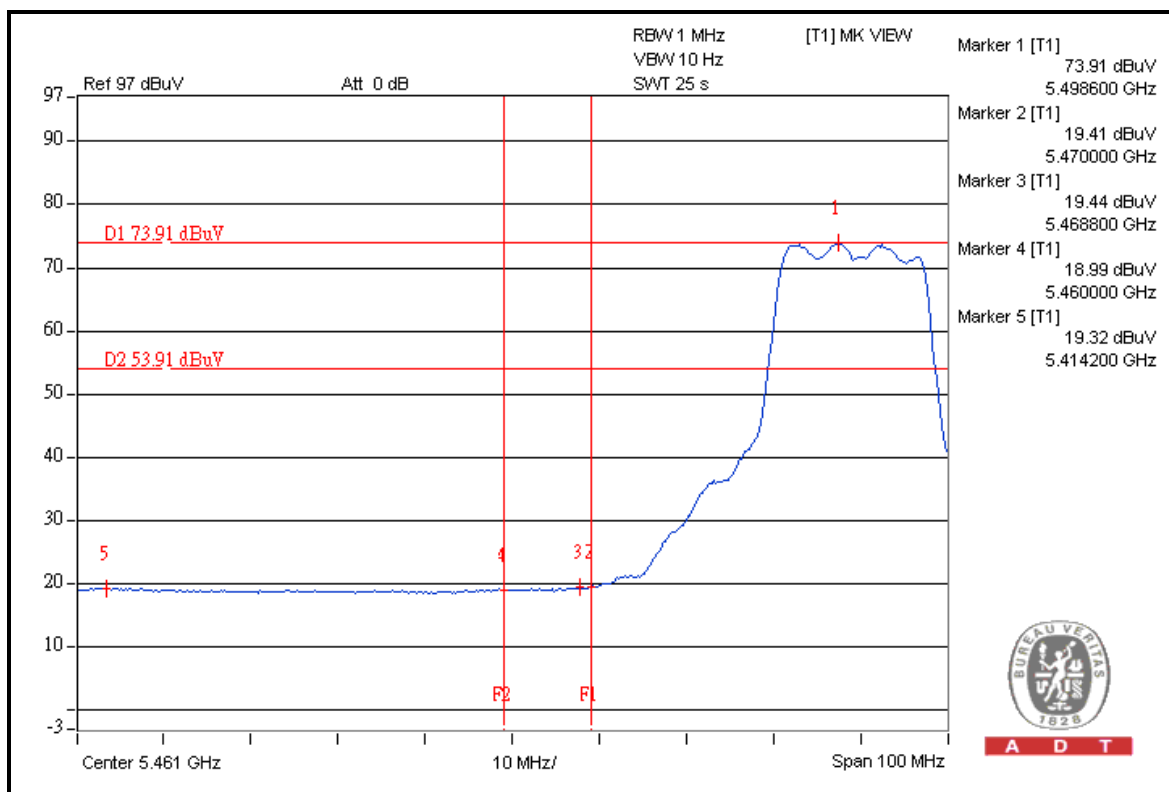
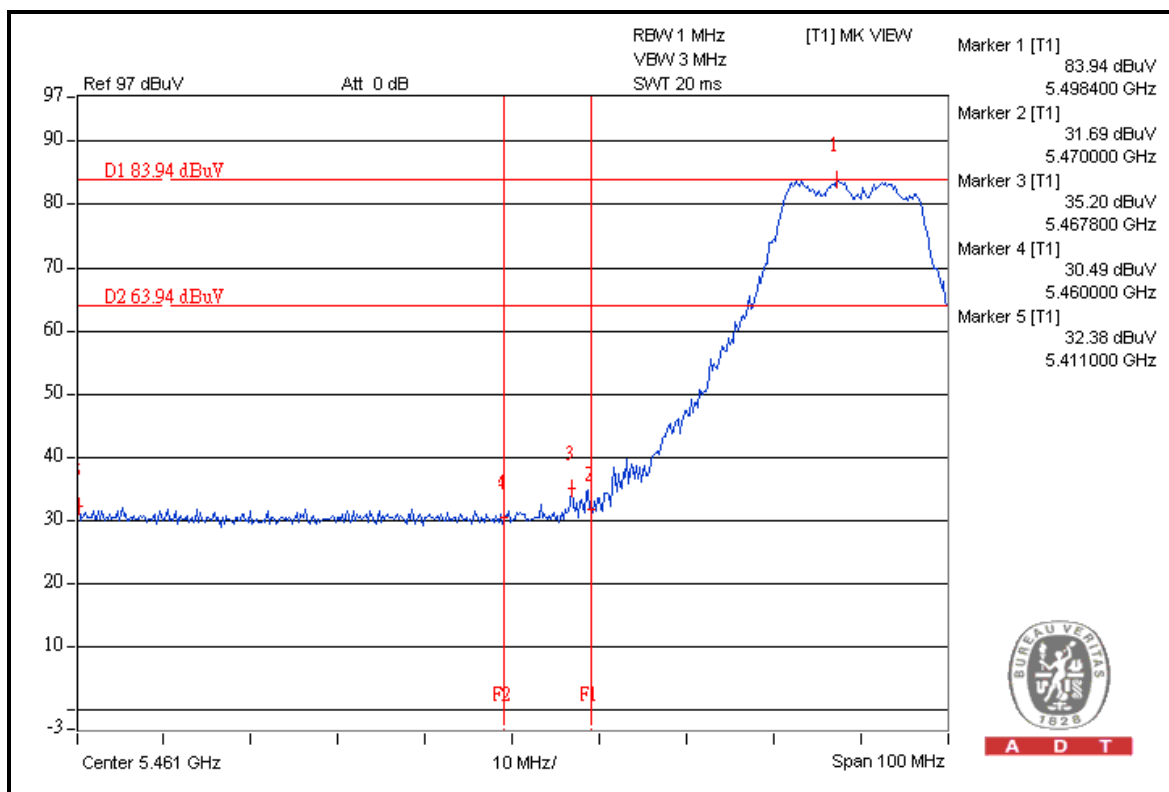



A D T

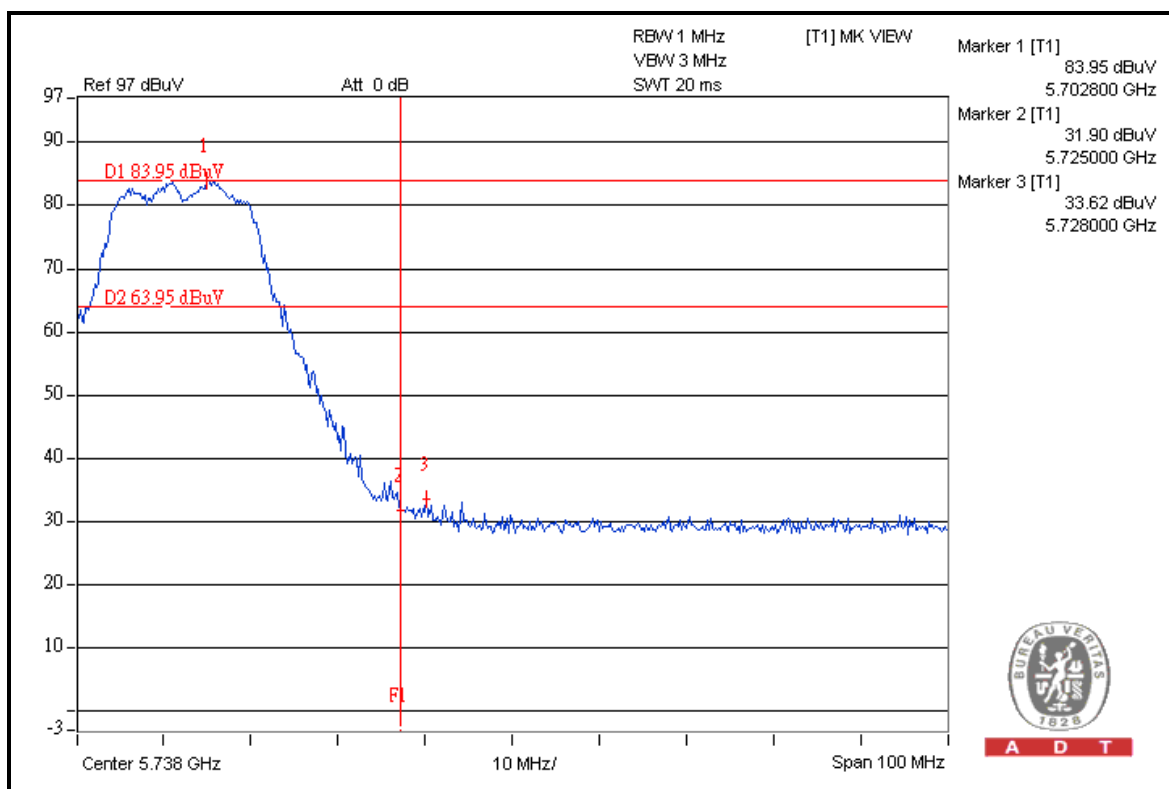
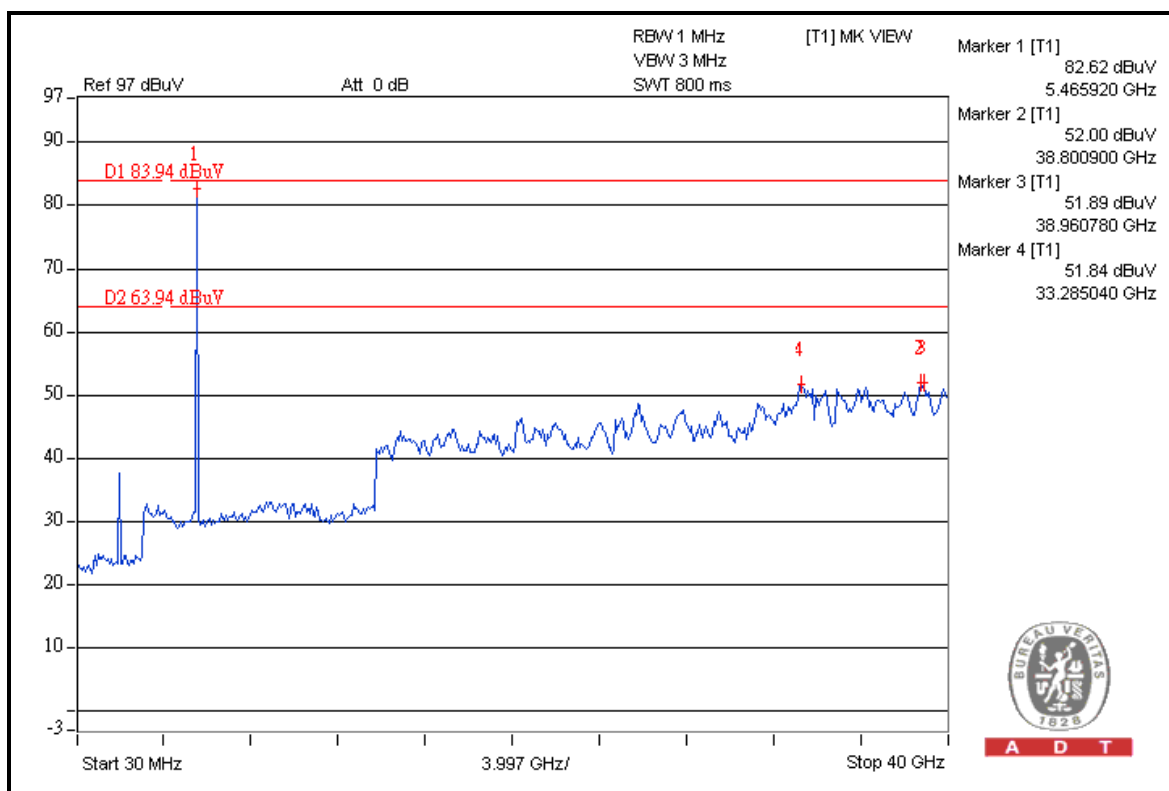





A D T

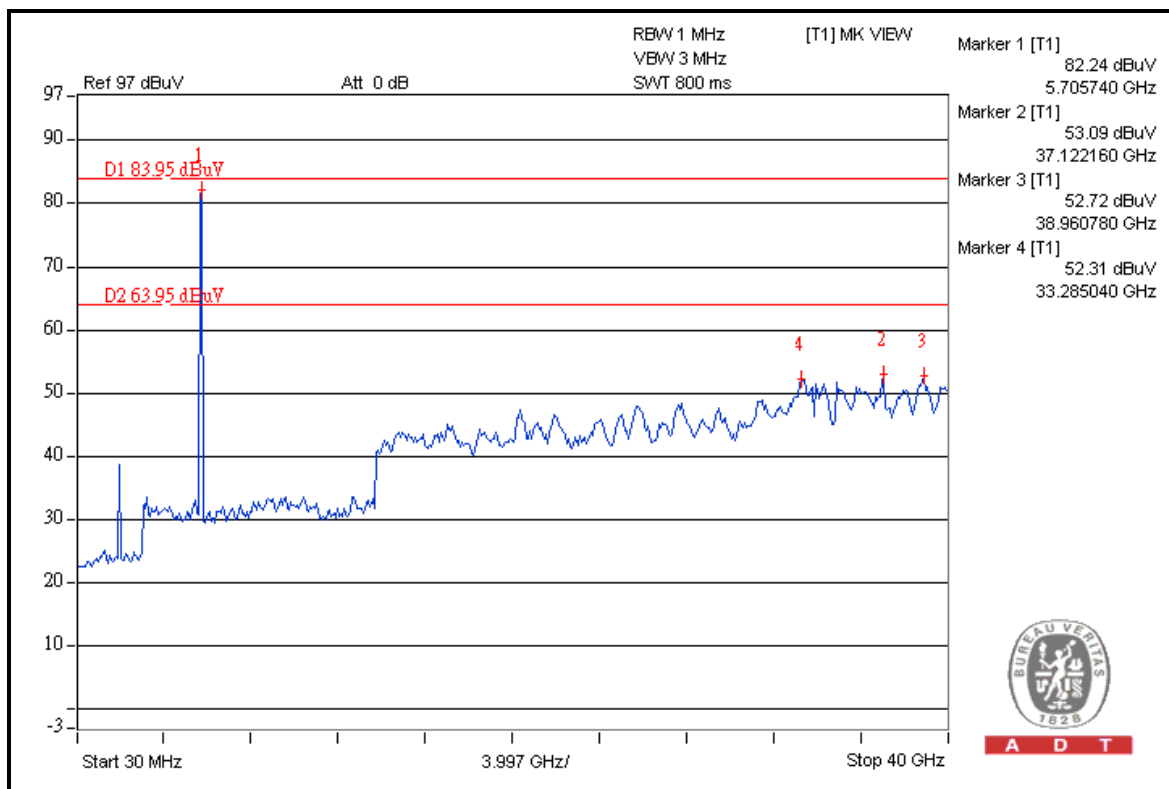
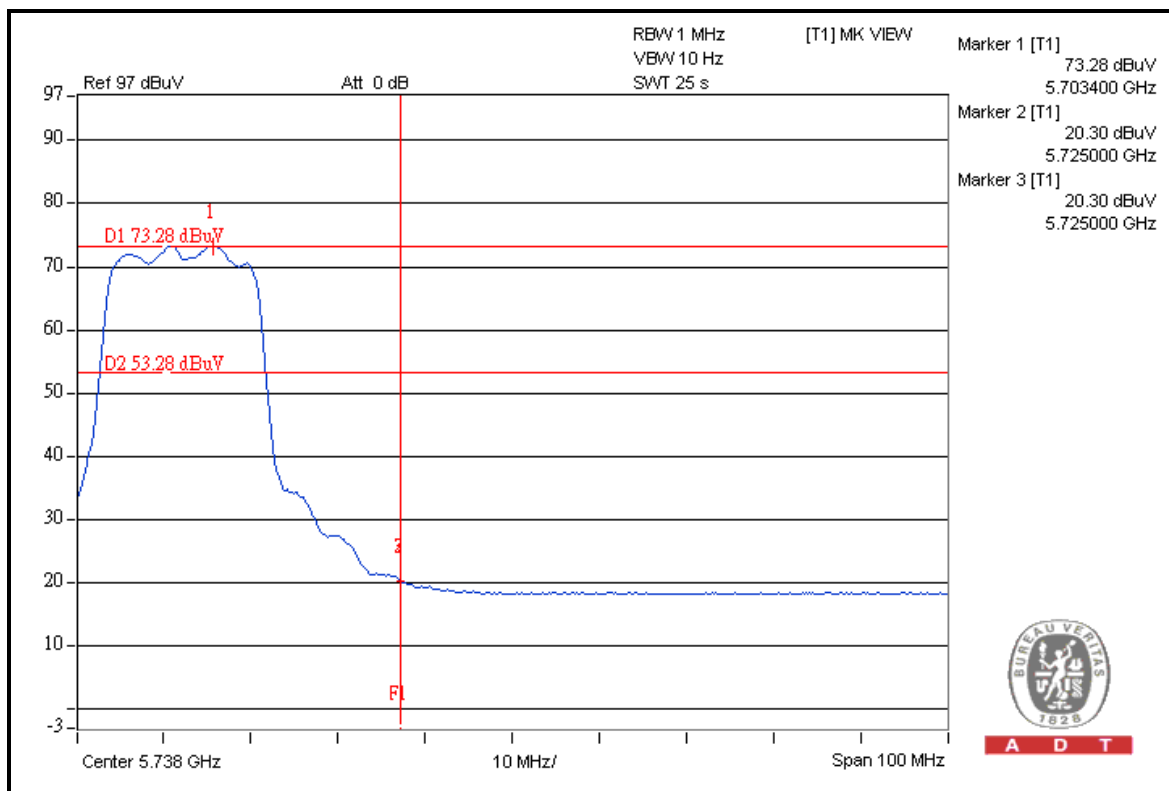



A D T

For Mode C:

5500MHz

RESTRICT BAND (5350 ~ 5460 MHz)

FREQUENCY (MHz)	FUNDAMENTAL EMISSION (dBuV/m)	DELTA (dB)	MAXIMUM FIELD STRENGTH IN RESTRICT BAND (dBuV/m)	LIMIT (dBuV/m)
5500.00 (PK)	119.9	53.7	66.2	74.00
5500.00 (AV)	106.4	54.0	52.4	54.00

FREQUENCY BAND (5460 ~ 5470 MHz)

FREQUENCY (MHz)	FUNDAMENTAL EMISSION (dBuV/m)	DELTA (dB)	MAXIMUM FIELD STRENGTH (dBuV/m)	LIMIT (dBuV/m)
5500.00 (PK)	119.9	54.1	65.8	88.30

5700MHz

ABOVE 5725 MHz

FREQUENCY (MHz)	FUNDAMENTAL EMISSION (dBuV/m)	DELTA (dB)	MAXIMUM FIELD STRENGTH (dBuV/m)	LIMIT (dBuV/m)
5700.00 (PK)	119.7	54.5	65.2	88.30

**NOTE:**

1. Delta = Amplitude between the peak of the fundamental and the peak of the band edge emission. Please check following 3 pages.
2. Maximum field strength in restrict band = Fundamental emission – Delta.



A D T

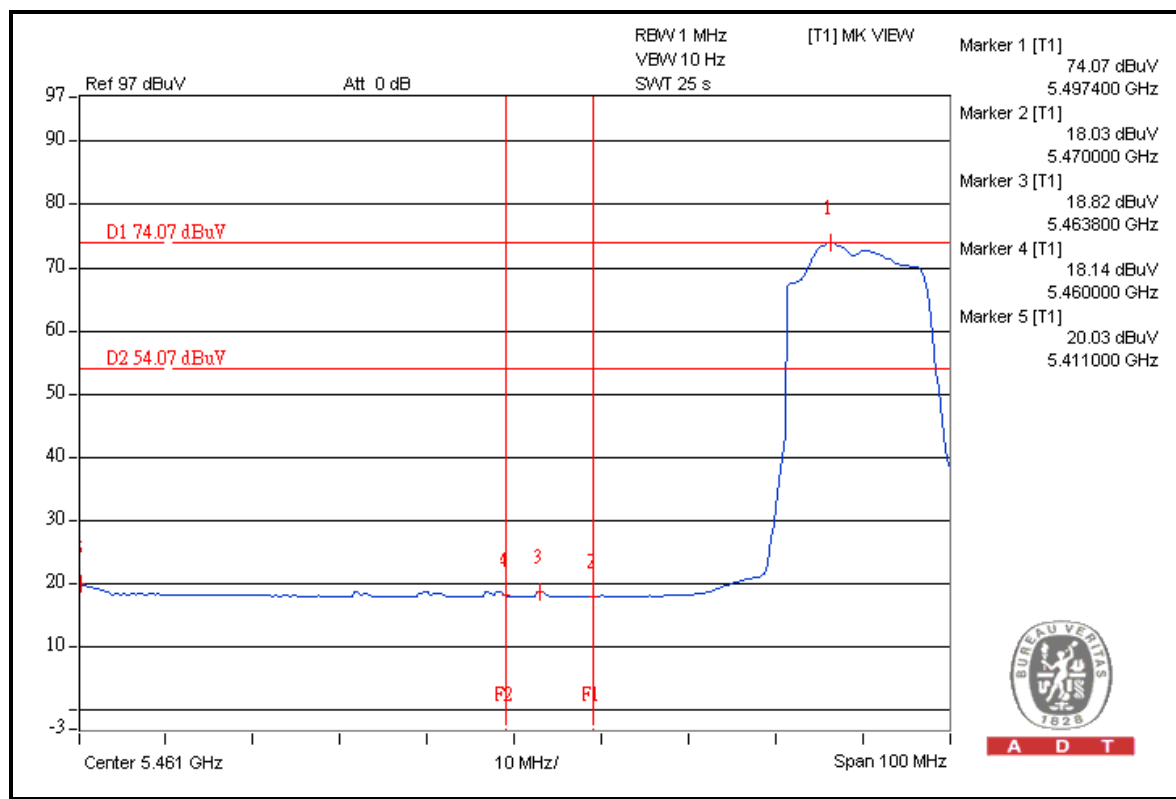
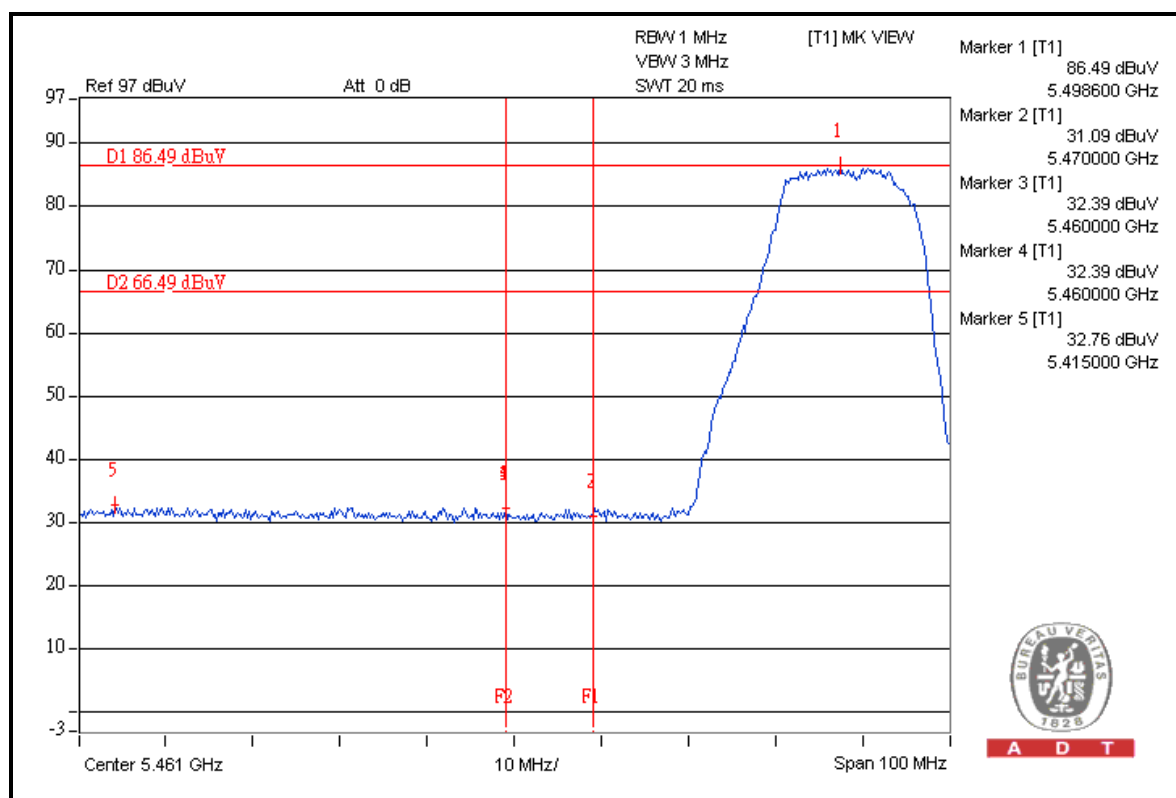



A D T

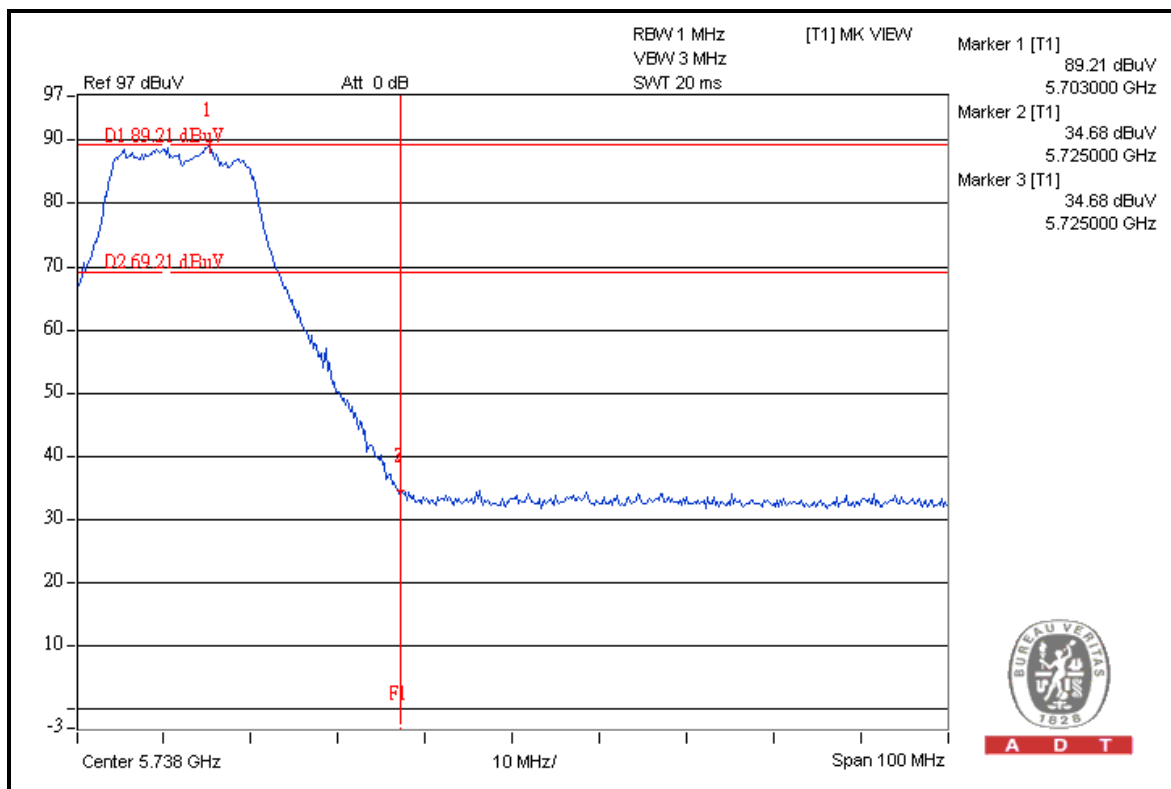
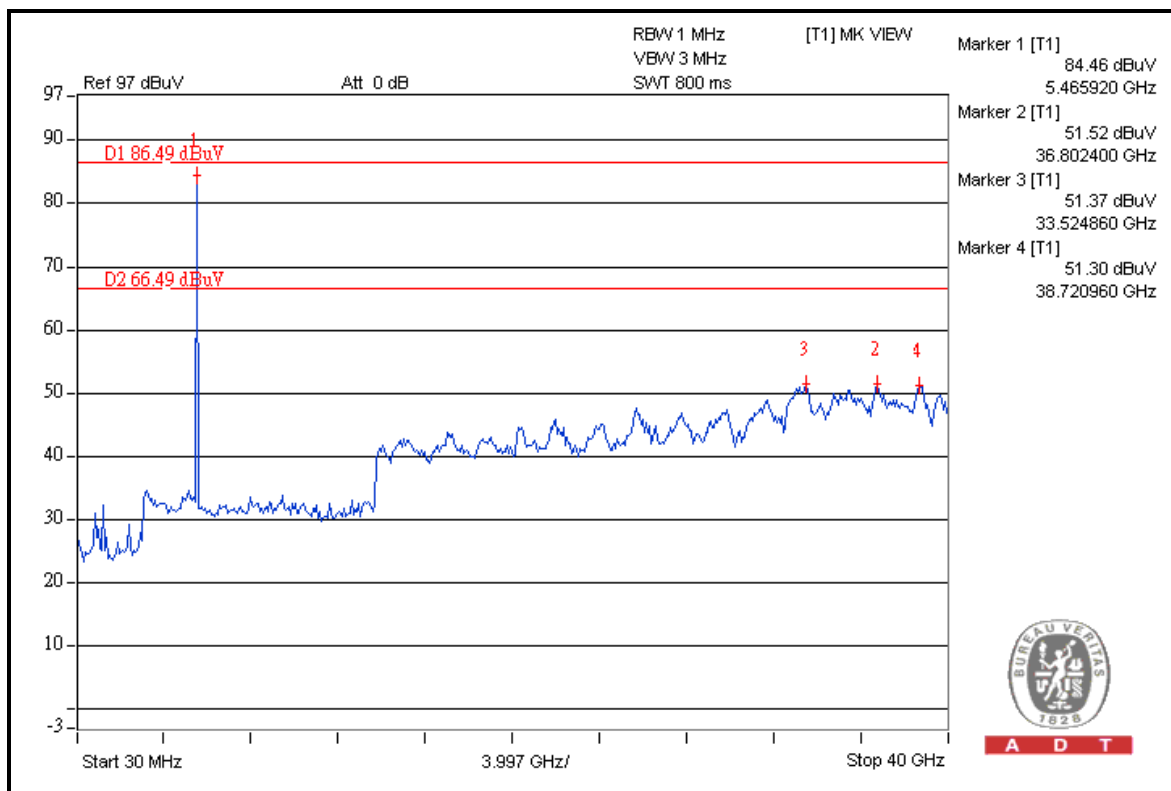



A D T

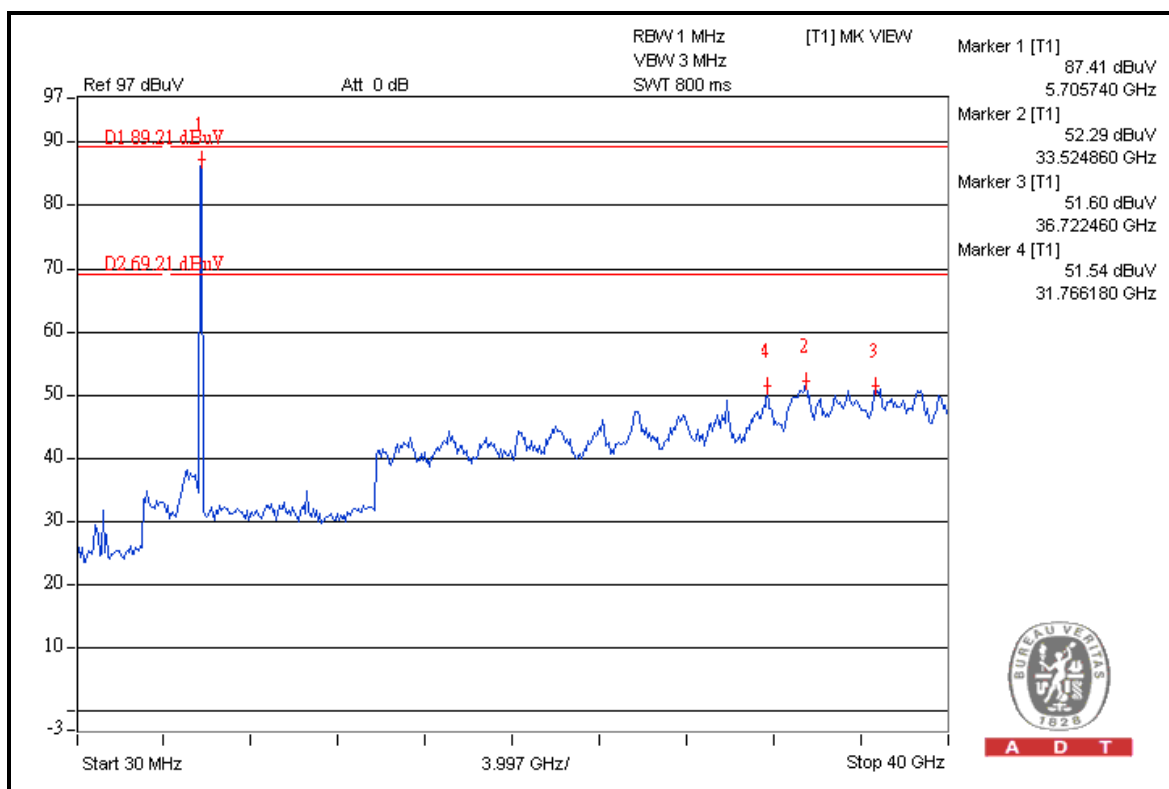
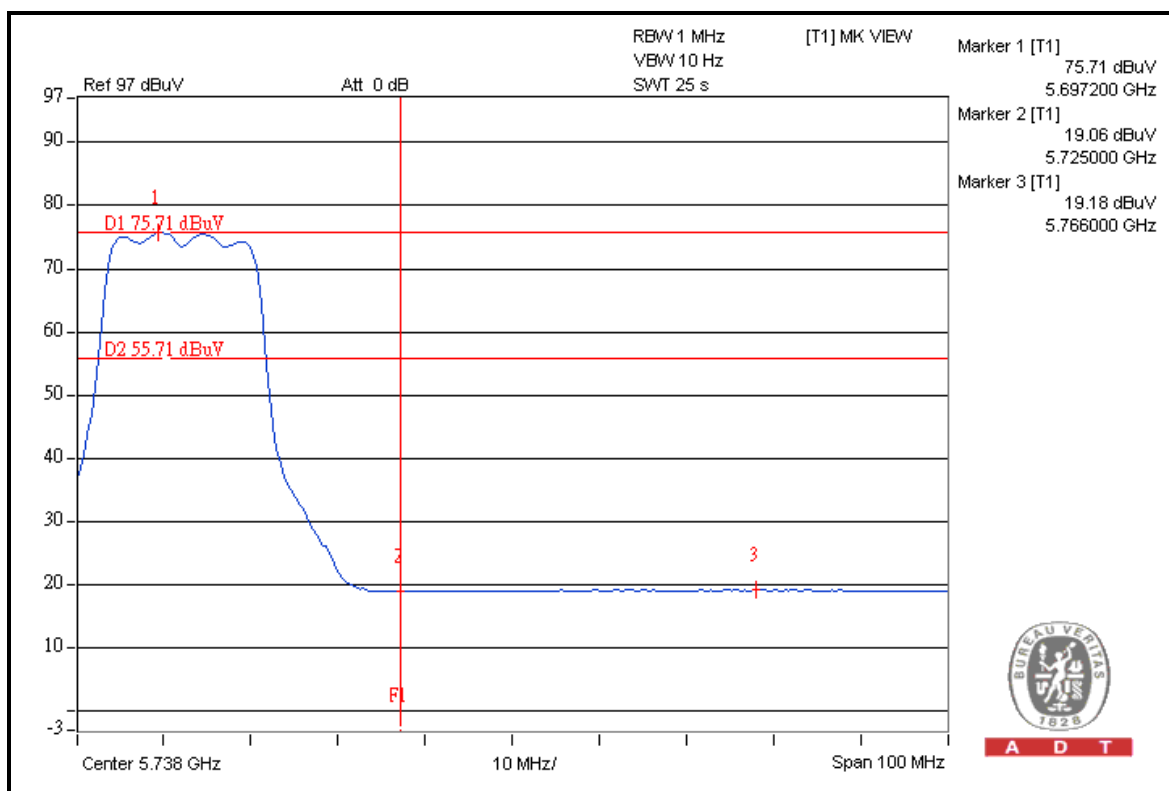



A D T

## FOR 5500-5700MHz BAND: 802.11n (20MHz)

For Mode A:

### 5500MHz

#### RESTRICT BAND (5350 ~ 5460 MHz)

FREQUENCY (MHz)	FUNDAMENTAL EMISSION (dBuV/m)	DELTA (dB)	MAXIMUM FIELD STRENGTH IN RESTRICT BAND (dBuV/m)	LIMIT (dBuV/m)
5500.00 (PK)	118.0	50.3	67.7	74.00
5500.00 (AV)	106.0	57.0	49.0	54.00

#### FREQUENCY BAND (5460 ~ 5470 MHz)

FREQUENCY (MHz)	FUNDAMENTAL EMISSION (dBuV/m)	DELTA (dB)	MAXIMUM FIELD STRENGTH (dBuV/m)	LIMIT (dBuV/m)
5500.00 (PK)	118.0	47.8	70.2	88.30

### 5700MHz

#### ABOVE 5725 MHz

FREQUENCY (MHz)	FUNDAMENTAL EMISSION (dBuV/m)	DELTA (dB)	MAXIMUM FIELD STRENGTH (dBuV/m)	LIMIT (dBuV/m)
5700.00 (PK)	117.1	47.7	69.4	88.30

#### NOTE:

1. Delta = Amplitude between the peak of the fundamental and the peak of the band edge emission. Please check following 3 pages.
2. Maximum field strength in restrict band = Fundamental emission – Delta.



A D T

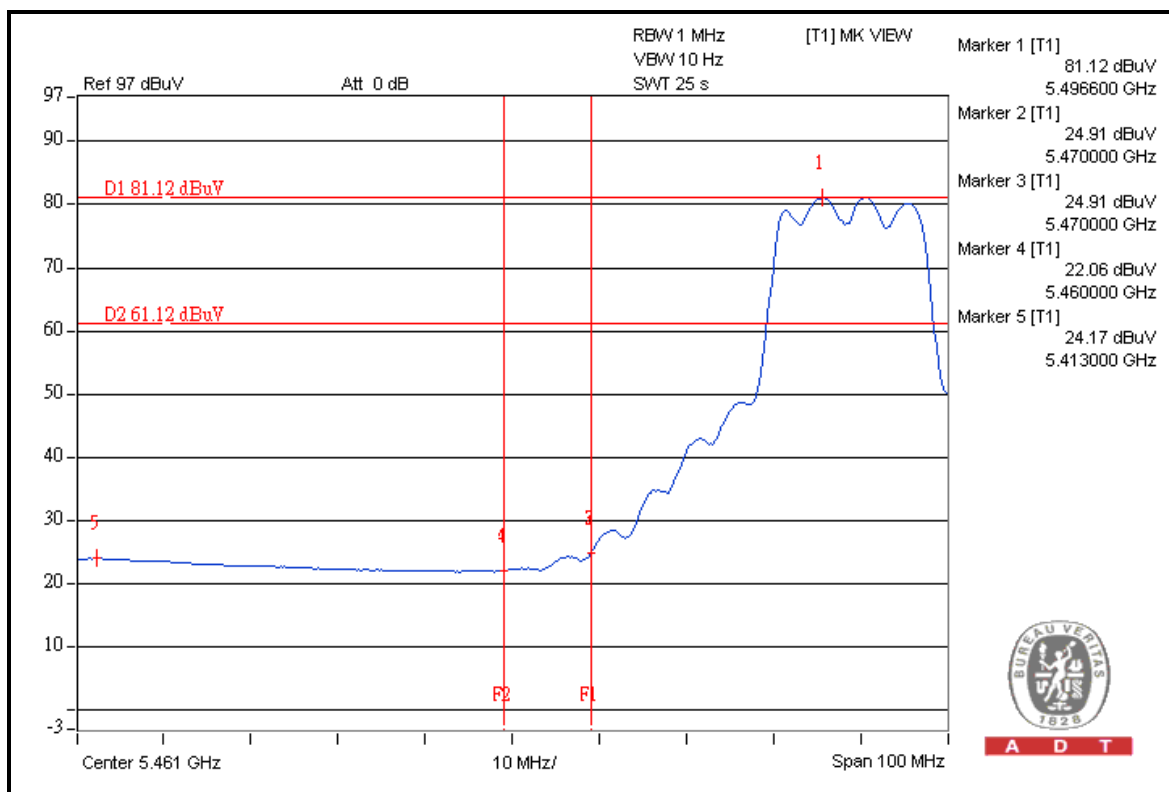
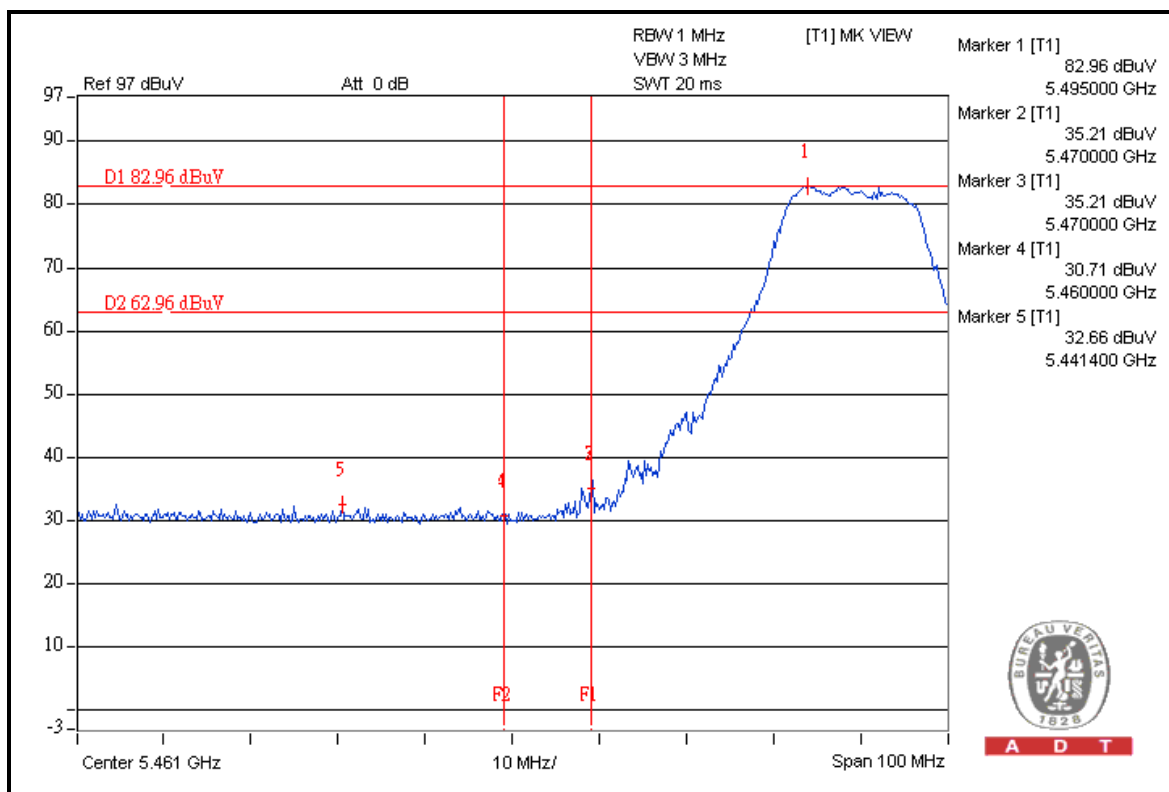



A D T

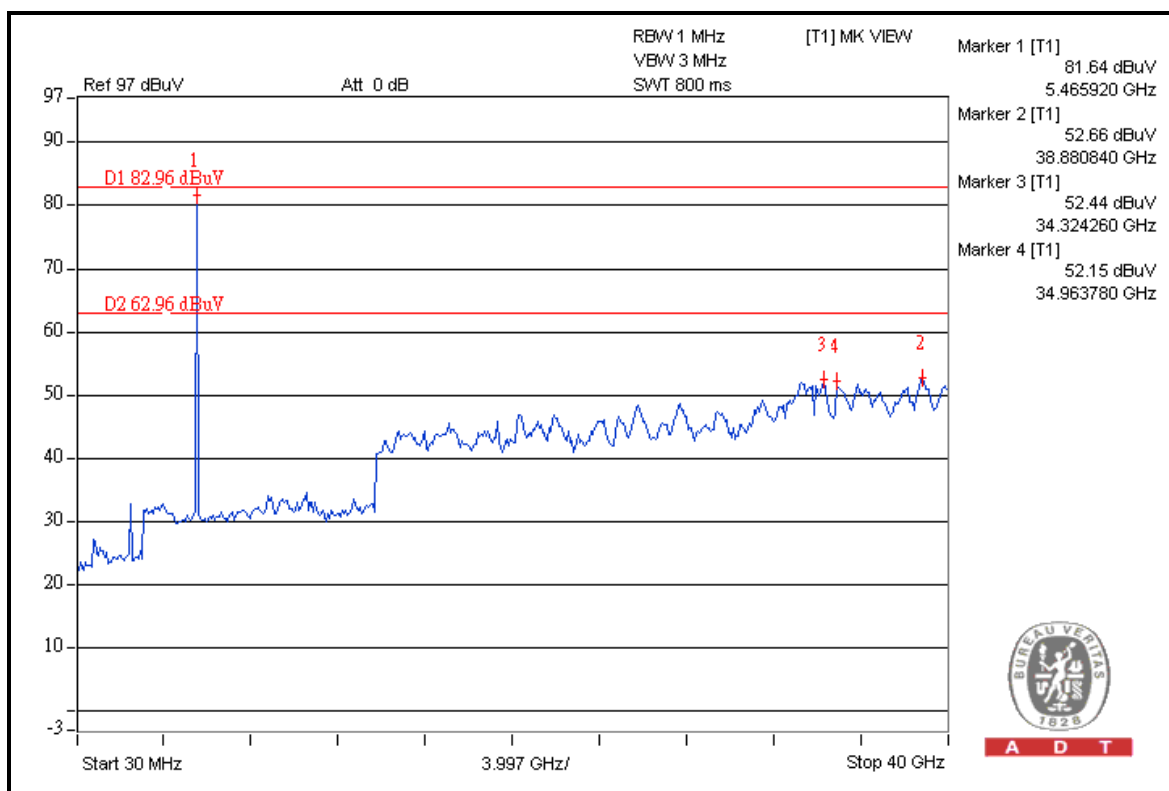

A D T

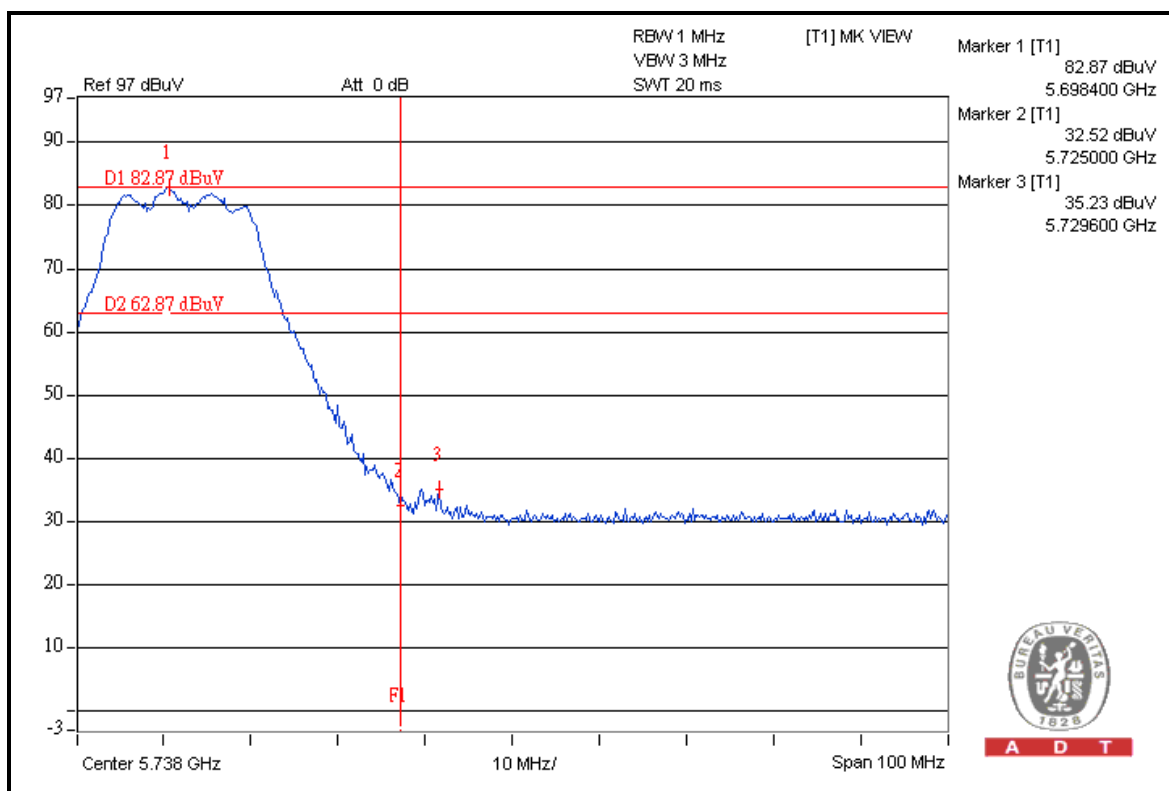

A D T





A D T

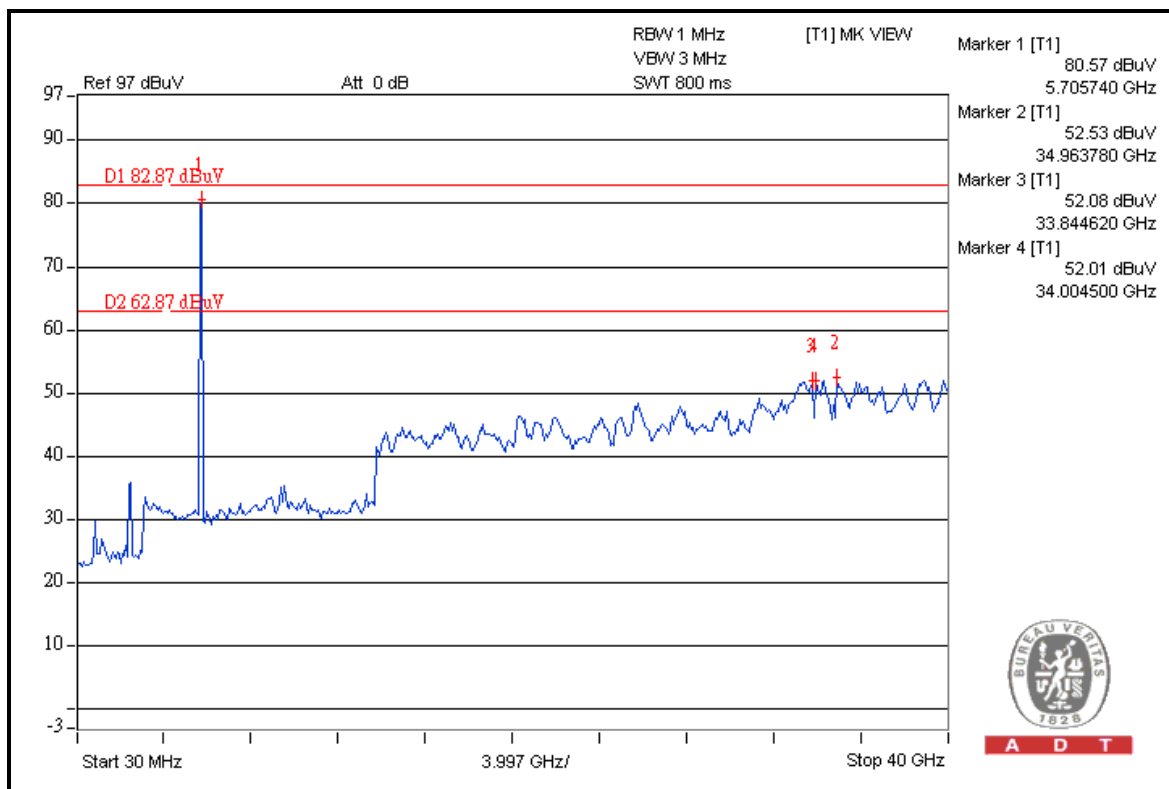
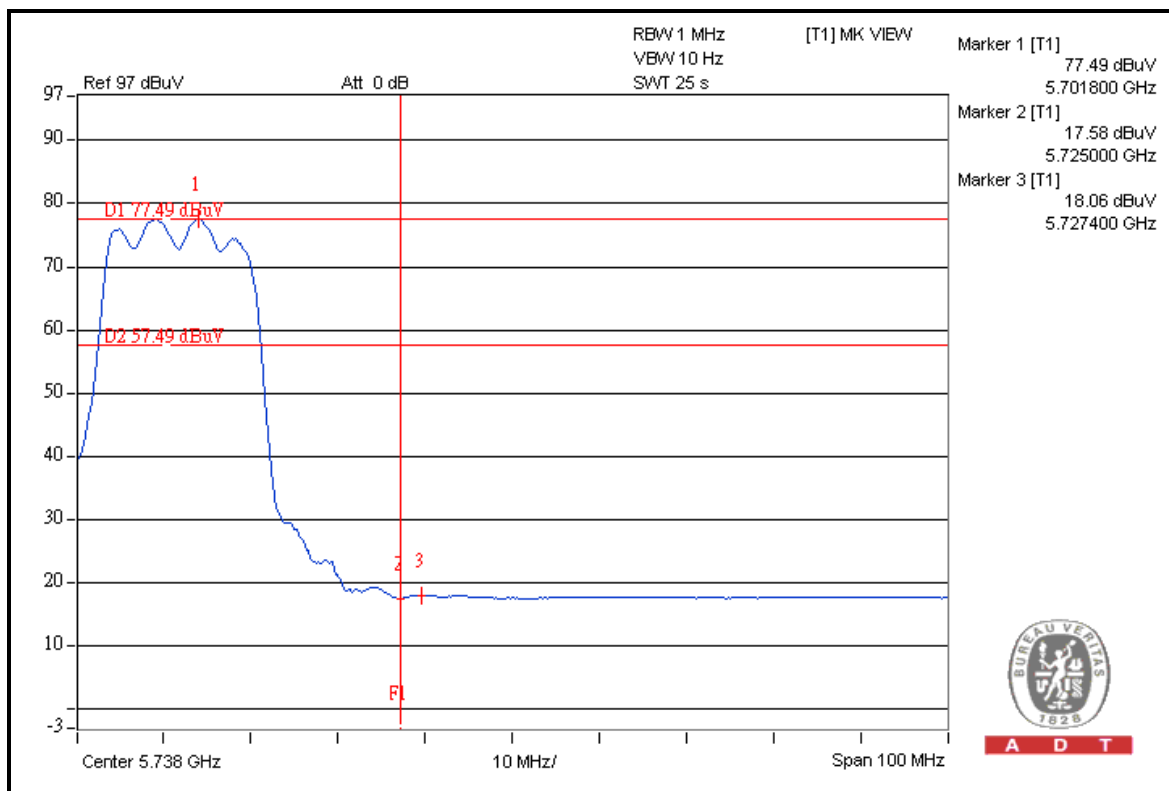



A D T

For Mode C:

5500MHz

RESTRICT BAND (5350 ~ 5460 MHz)

FREQUENCY (MHz)	FUNDAMENTAL EMISSION (dBuV/m)	DELTA (dB)	MAXIMUM FIELD STRENGTH IN RESTRICT BAND (dBuV/m)	LIMIT (dBuV/m)
5500.00 (PK)	120.8	52.2	68.6	74.00
5500.00 (AV)	107.2	54.4	52.8	54.00

FREQUENCY BAND (5460 ~ 5470 MHz)

FREQUENCY (MHz)	FUNDAMENTAL EMISSION (dBuV/m)	DELTA (dB)	MAXIMUM FIELD STRENGTH (dBuV/m)	LIMIT (dBuV/m)
5500.00 (PK)	120.8	53.1	67.7	88.30

5700MHz

ABOVE 5725 MHz

FREQUENCY (MHz)	FUNDAMENTAL EMISSION (dBuV/m)	DELTA (dB)	MAXIMUM FIELD STRENGTH (dBuV/m)	LIMIT (dBuV/m)
5700.00 (PK)	120.5	54.1	66.4	88.30

**NOTE:**

1. Delta = Amplitude between the peak of the fundamental and the peak of the band edge emission. Please check following 3 pages.
2. Maximum field strength in restrict band = Fundamental emission – Delta.



A D T

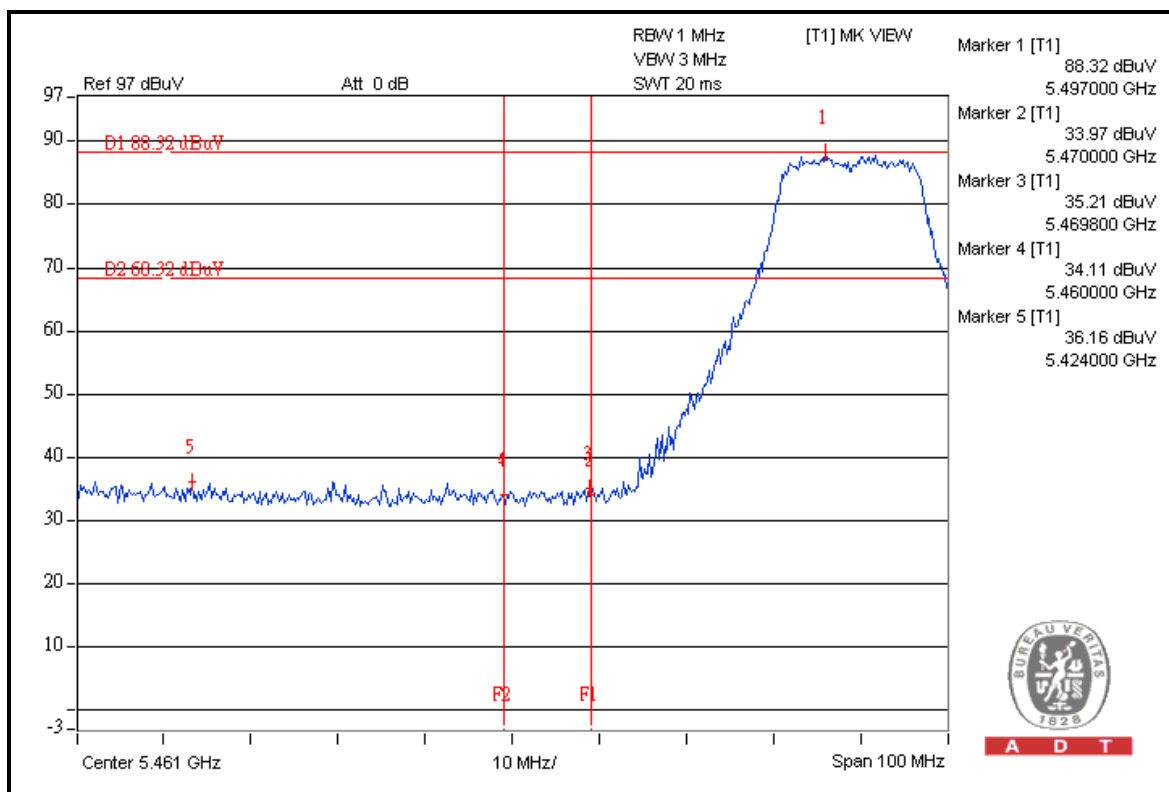

A D T

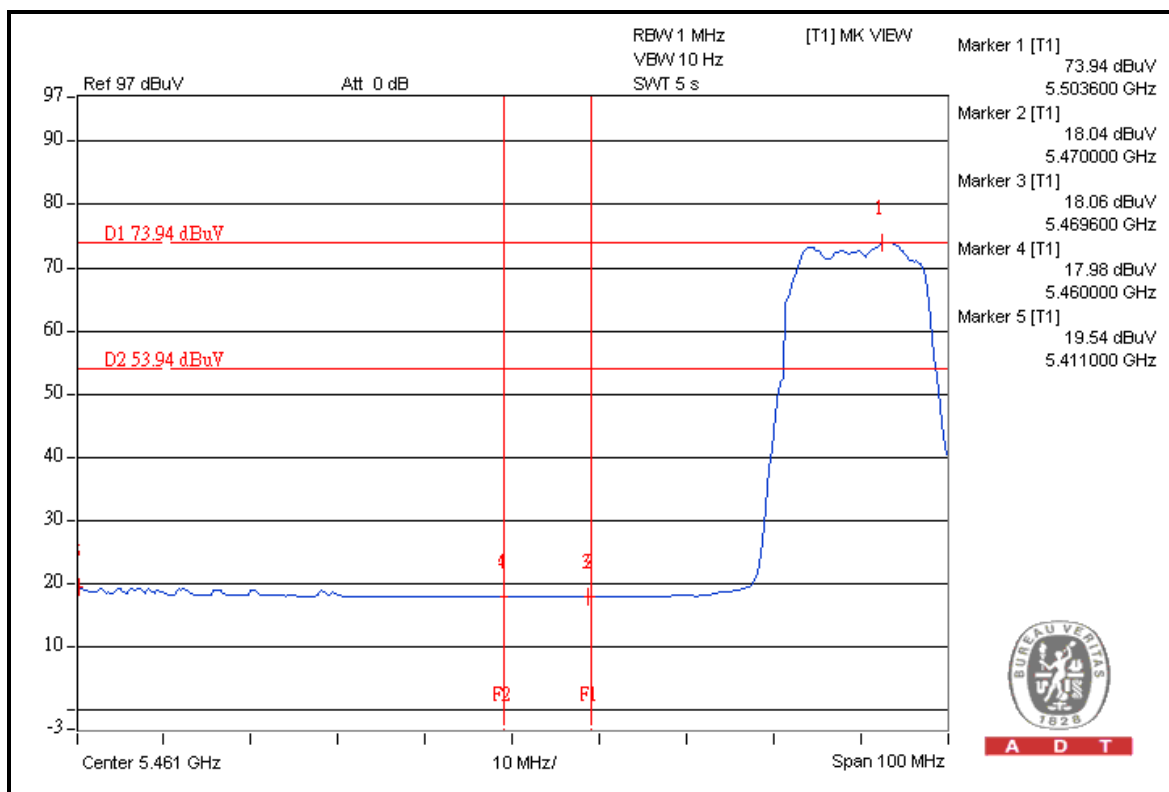

A D T



A D T

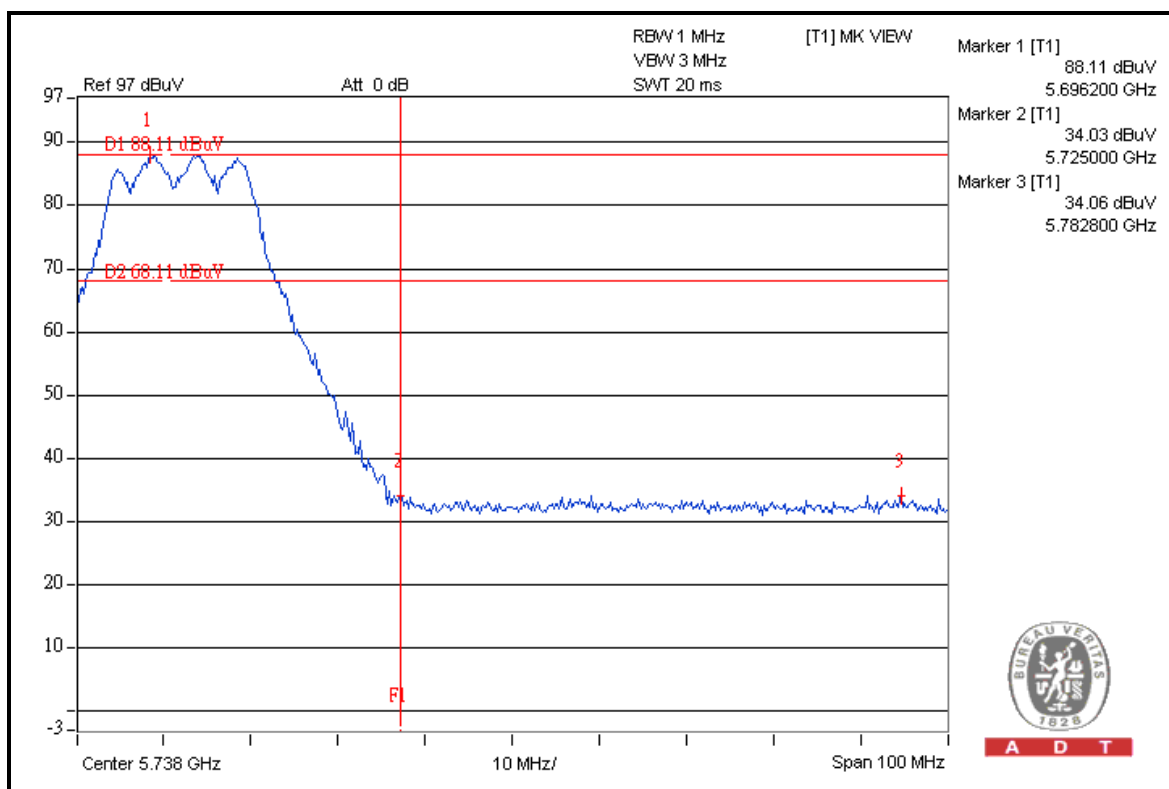
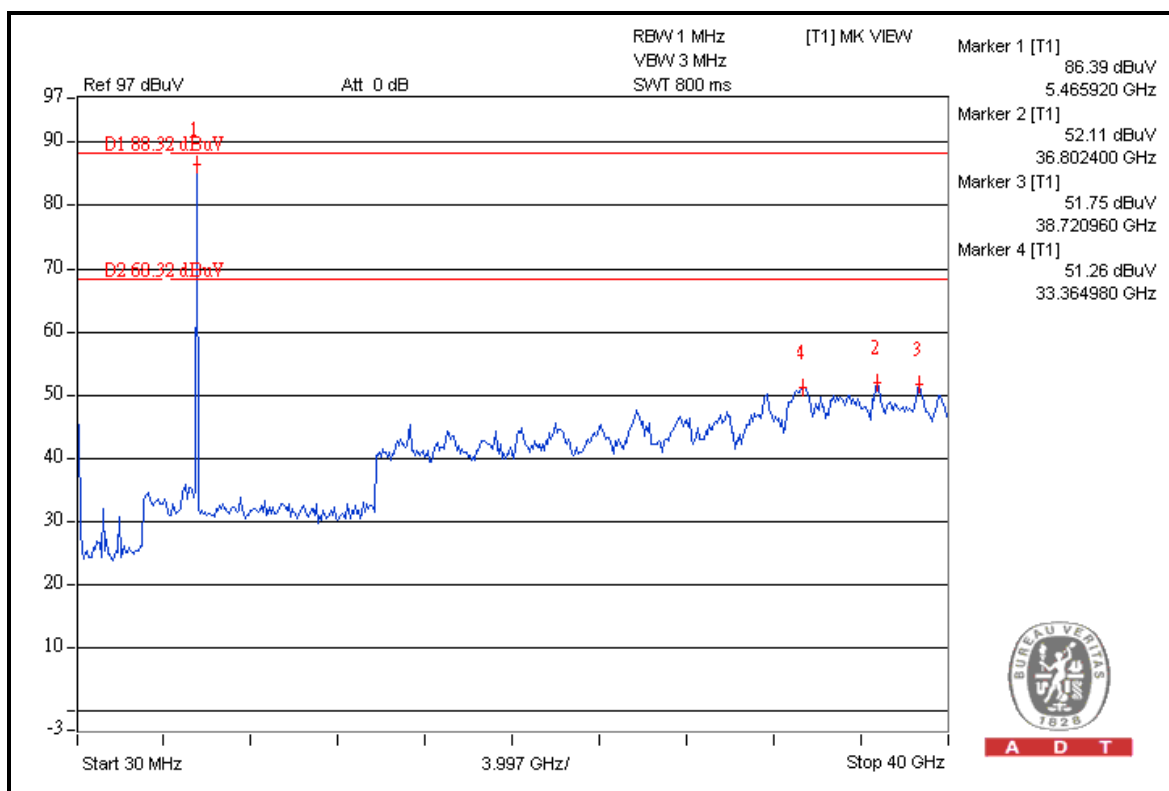



A D T

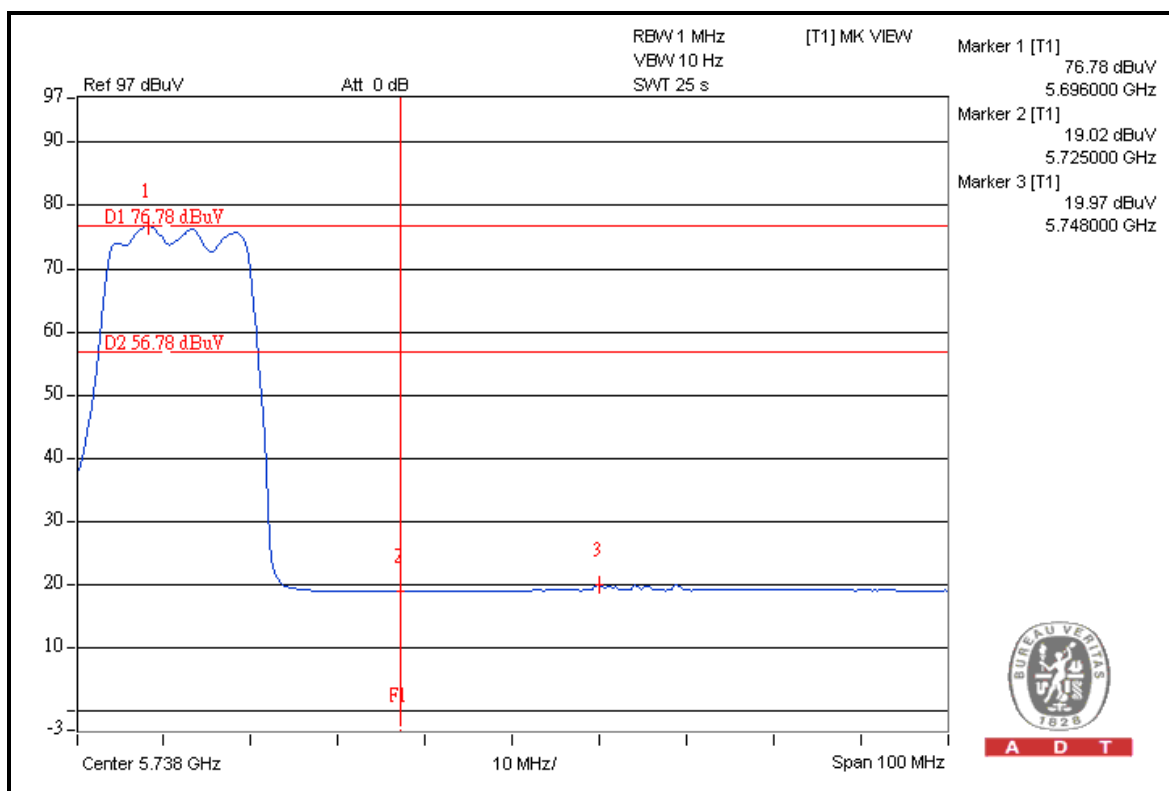

A D T

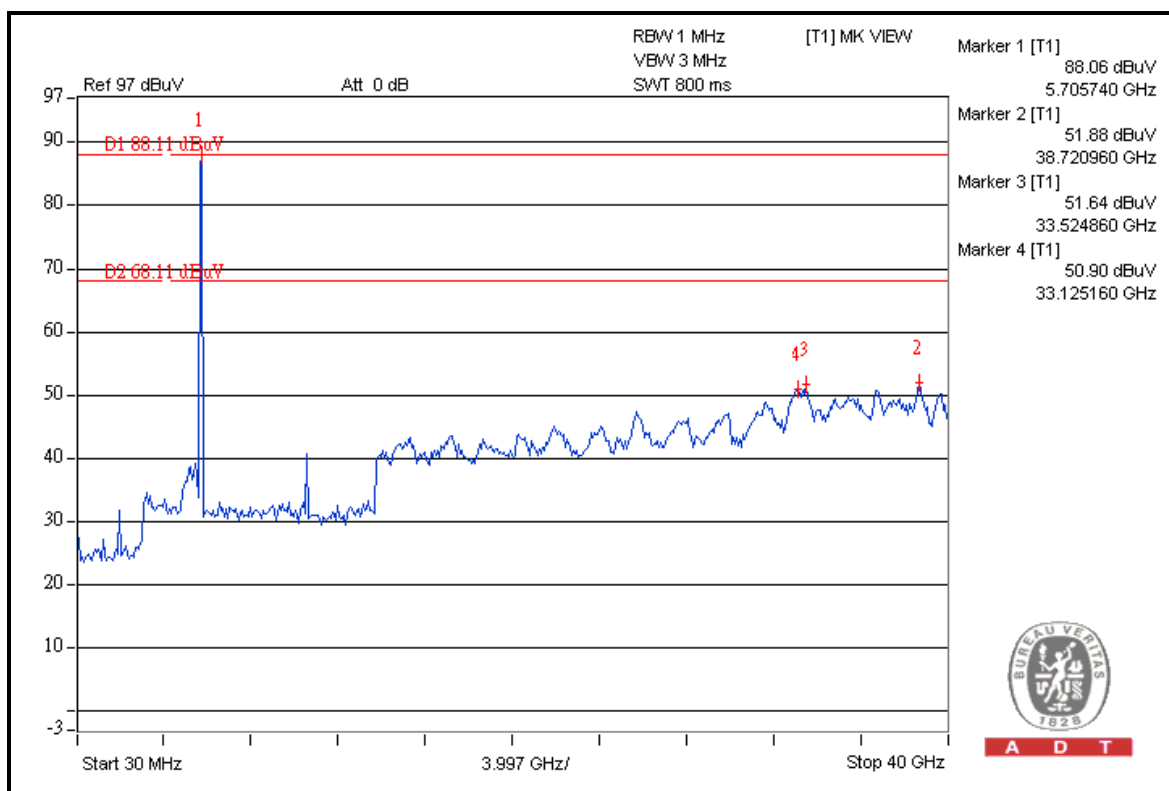

A D T



A D T

## FOR 5500-5700MHz BAND: 802.11n (40MHz)

For Mode A:

### 5510MHz

#### RESTRICT BAND (5350 ~ 5460 MHz)

FREQUENCY (MHz)	FUNDAMENTAL EMISSION (dBuV/m)	DELTA (dB)	MAXIMUM FIELD STRENGTH IN RESTRICT BAND (dBuV/m)	LIMIT (dBuV/m)
5510.00 (PK)	113.6	42.2	71.4	74.00
5510.00 (AV)	101.8	50.0	51.8	54.00

#### FREQUENCY BAND (5460 ~ 5470 MHz)

FREQUENCY (MHz)	FUNDAMENTAL EMISSION (dBuV/m)	DELTA (dB)	MAXIMUM FIELD STRENGTH (dBuV/m)	LIMIT (dBuV/m)
5510.00 (PK)	113.6	33.5	80.1	88.30

### 5670MHz

#### ABOVE 5725 MHz

FREQUENCY (MHz)	FUNDAMENTAL EMISSION (dBuV/m)	DELTA (dB)	MAXIMUM FIELD STRENGTH (dBuV/m)	LIMIT (dBuV/m)
5670.00 (PK)	114.9	49.7	65.2	88.30

#### NOTE:

1. Delta = Amplitude between the peak of the fundamental and the peak of the band edge emission. Please check following 3 pages.
2. Maximum field strength in restrict band = Fundamental emission – Delta.



A D T

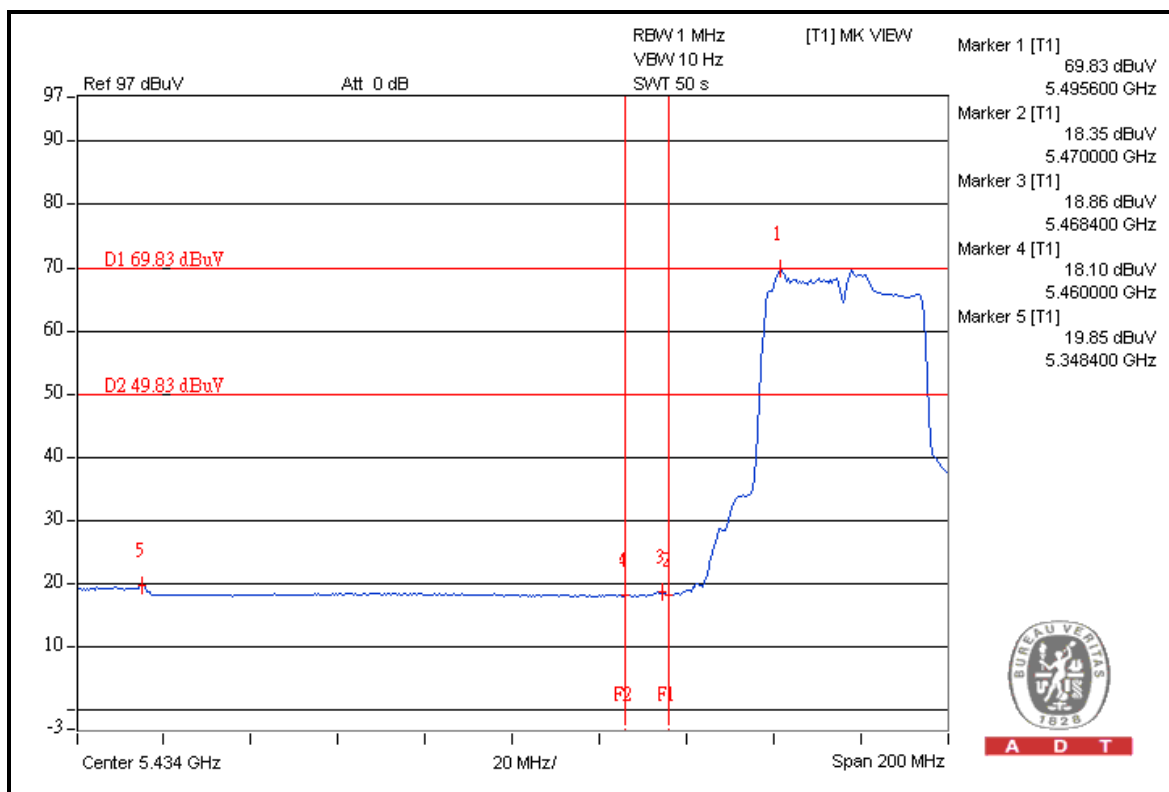
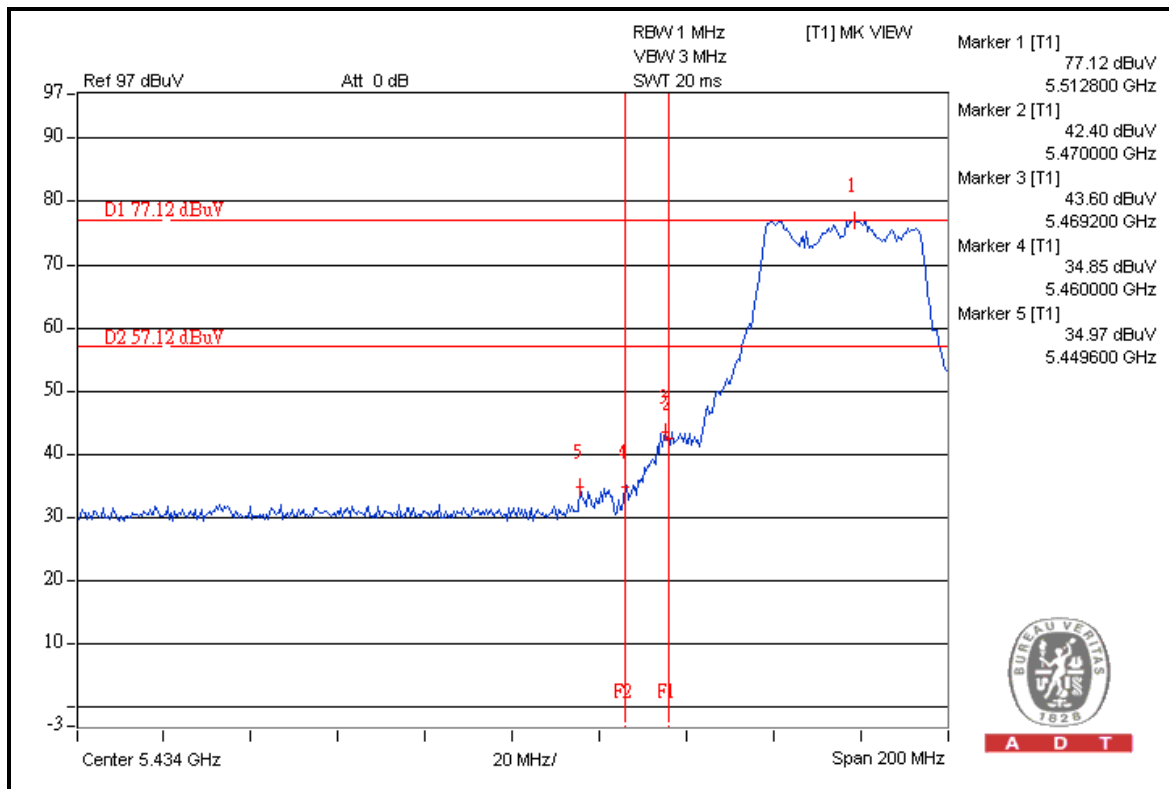



A D T

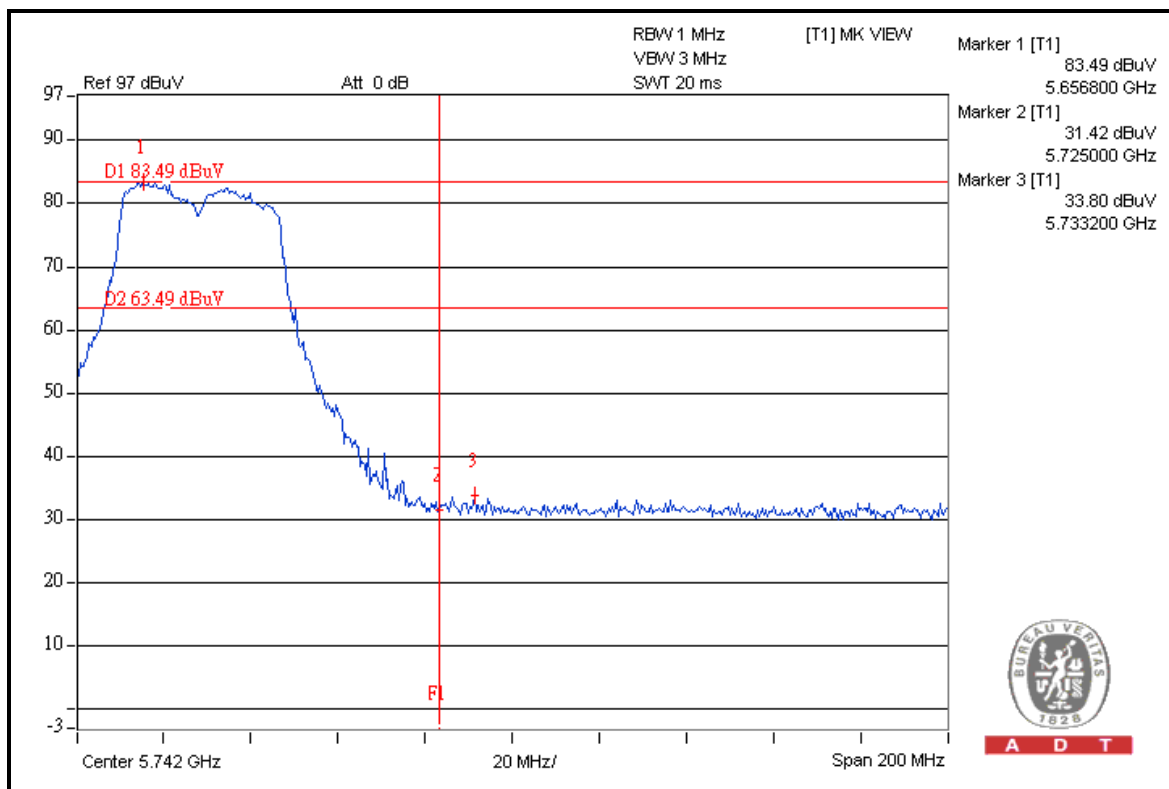
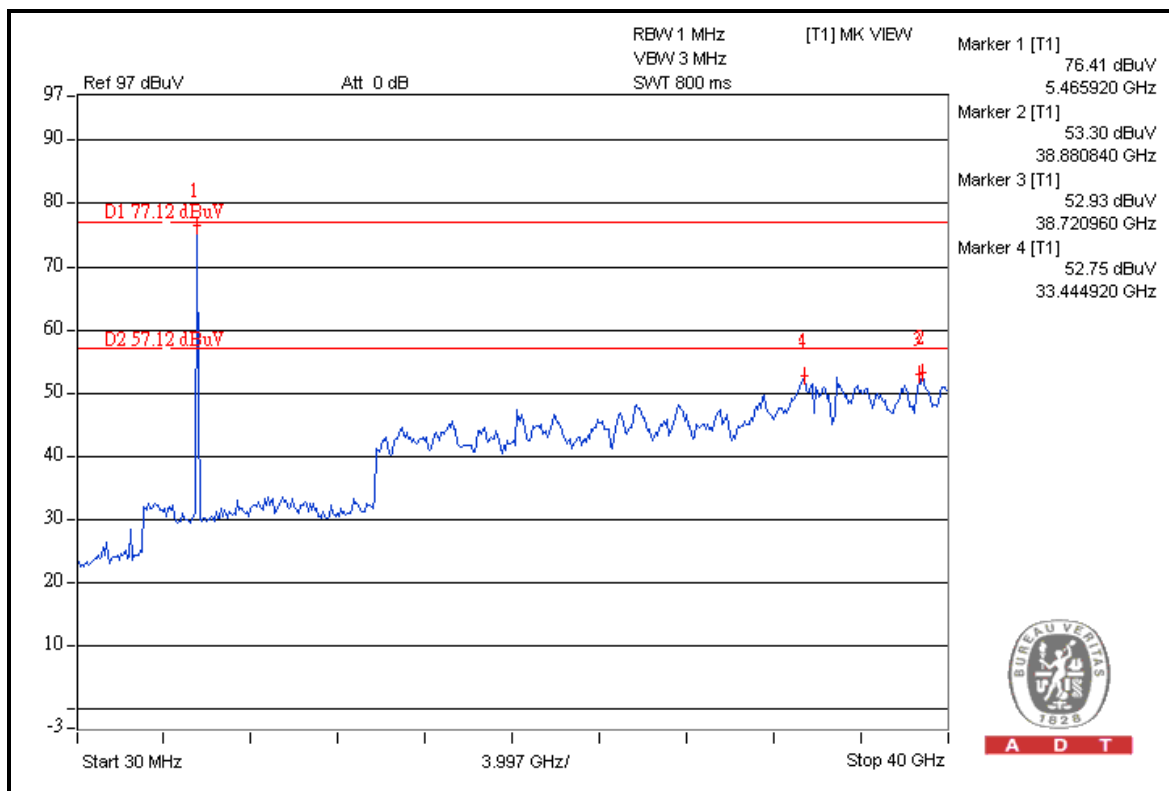





A D T

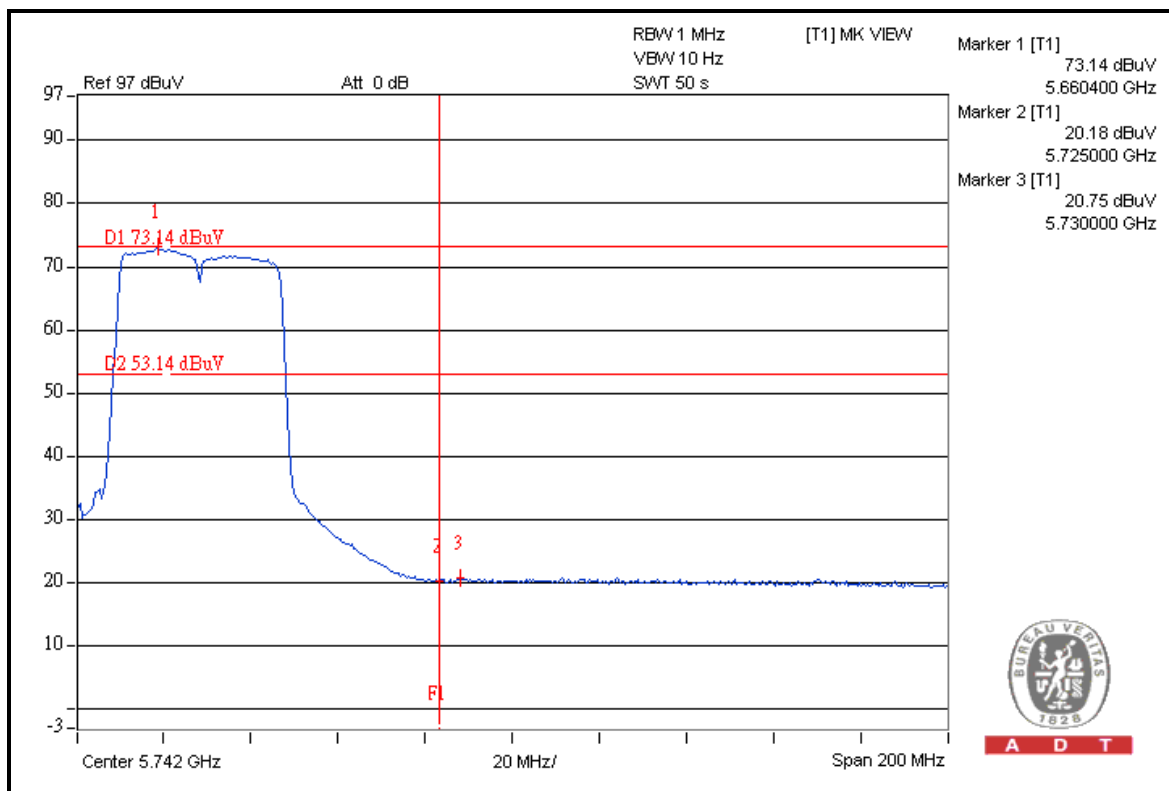

A D T

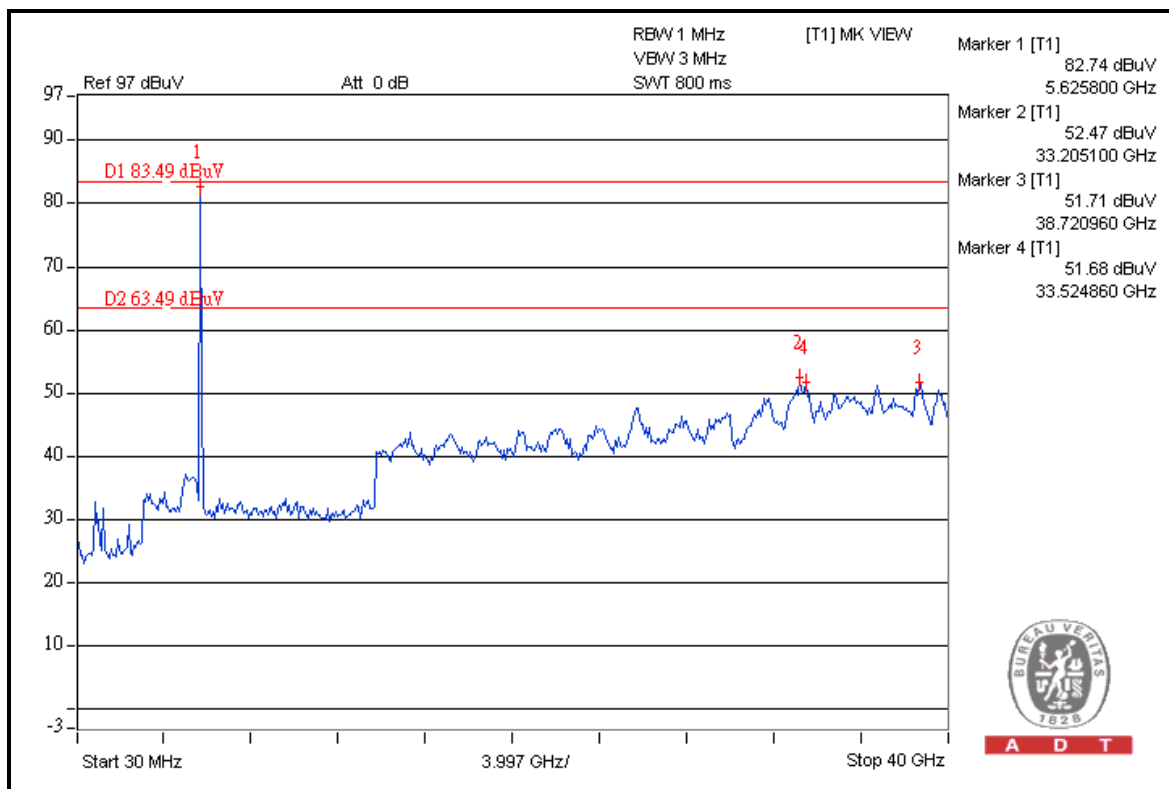

A D T



A D T

For Mode C:

5510MHz

RESTRICT BAND (5350 ~ 5460 MHz)

FREQUENCY (MHz)	FUNDAMENTAL EMISSION (dBuV/m)	DELTA (dB)	MAXIMUM FIELD STRENGTH IN RESTRICT BAND (dBuV/m)	LIMIT (dBuV/m)
5510.00 (PK)	118.9	52.4	66.5	74.00
5510.00 (AV)	106.0	53.1	52.9	54.00

FREQUENCY BAND (5460 ~ 5470 MHz)

FREQUENCY (MHz)	FUNDAMENTAL EMISSION (dBuV/m)	DELTA (dB)	MAXIMUM FIELD STRENGTH (dBuV/m)	LIMIT (dBuV/m)
5510.00 (PK)	118.9	54.3	64.6	88.30

5670MHz

ABOVE 5725 MHz

FREQUENCY (MHz)	FUNDAMENTAL EMISSION (dBuV/m)	DELTA (dB)	MAXIMUM FIELD STRENGTH (dBuV/m)	LIMIT (dBuV/m)
5670.00 (PK)	117.1	51.7	65.4	88.30

**NOTE:**

1. Delta = Amplitude between the peak of the fundamental and the peak of the band edge emission. Please check following 3 pages.
2. Maximum field strength in restrict band = Fundamental emission – Delta.



A D T

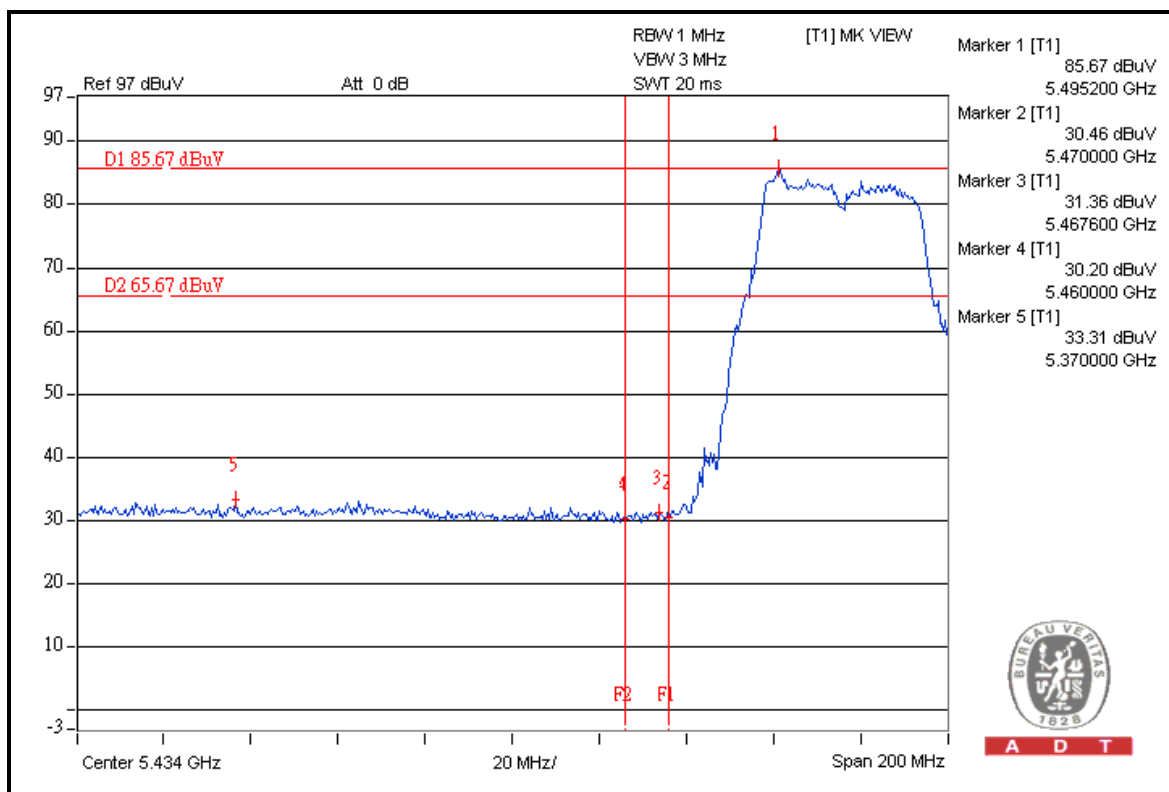

A D T

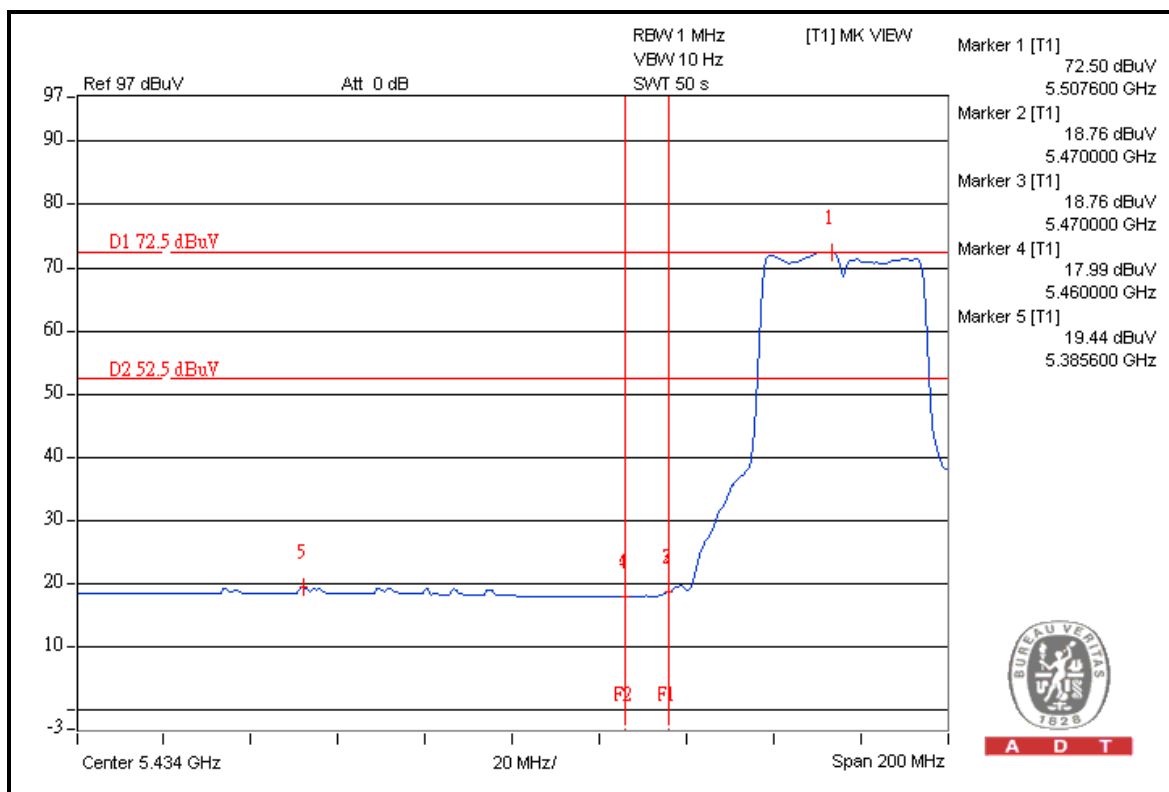

A D T



A D T

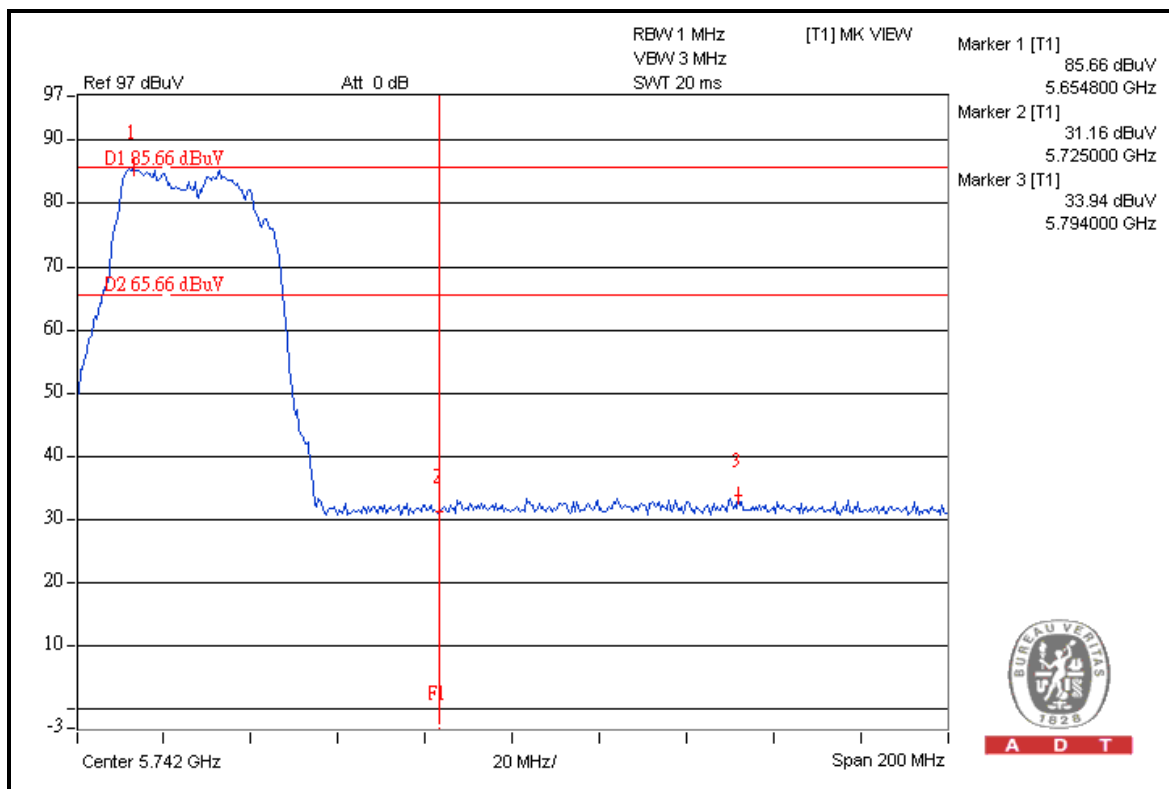
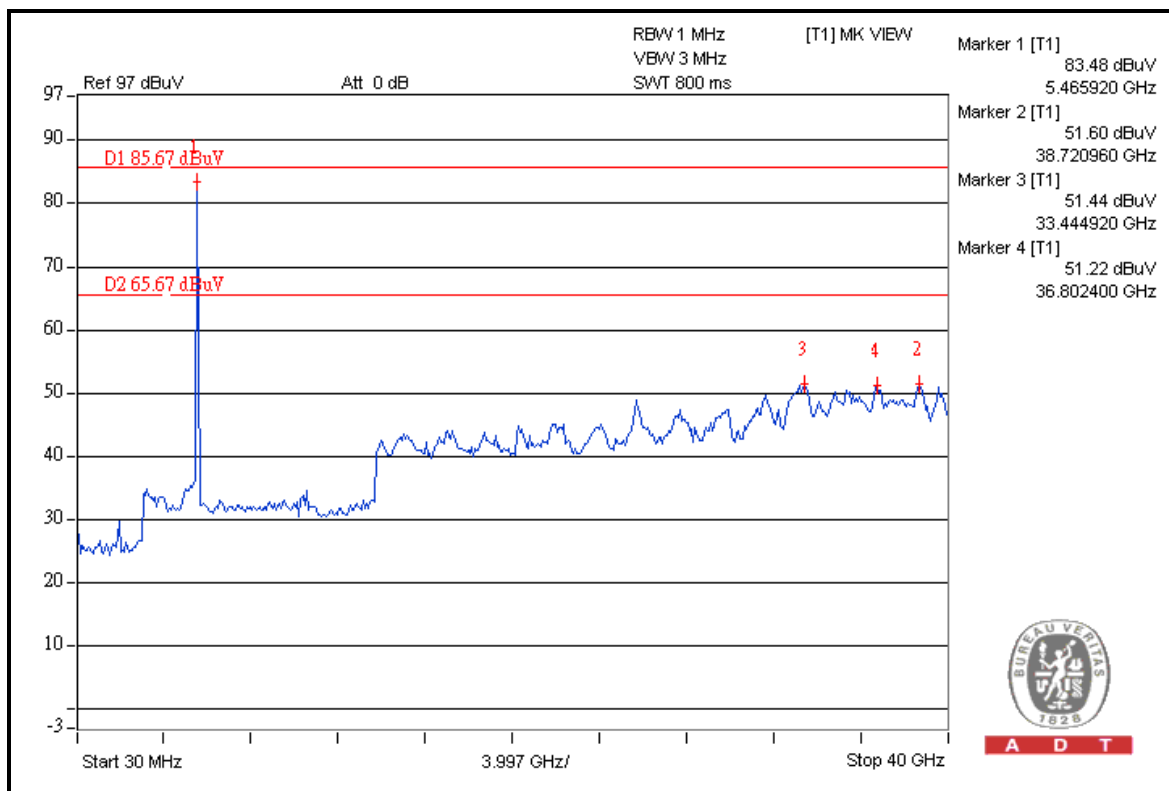



A D T

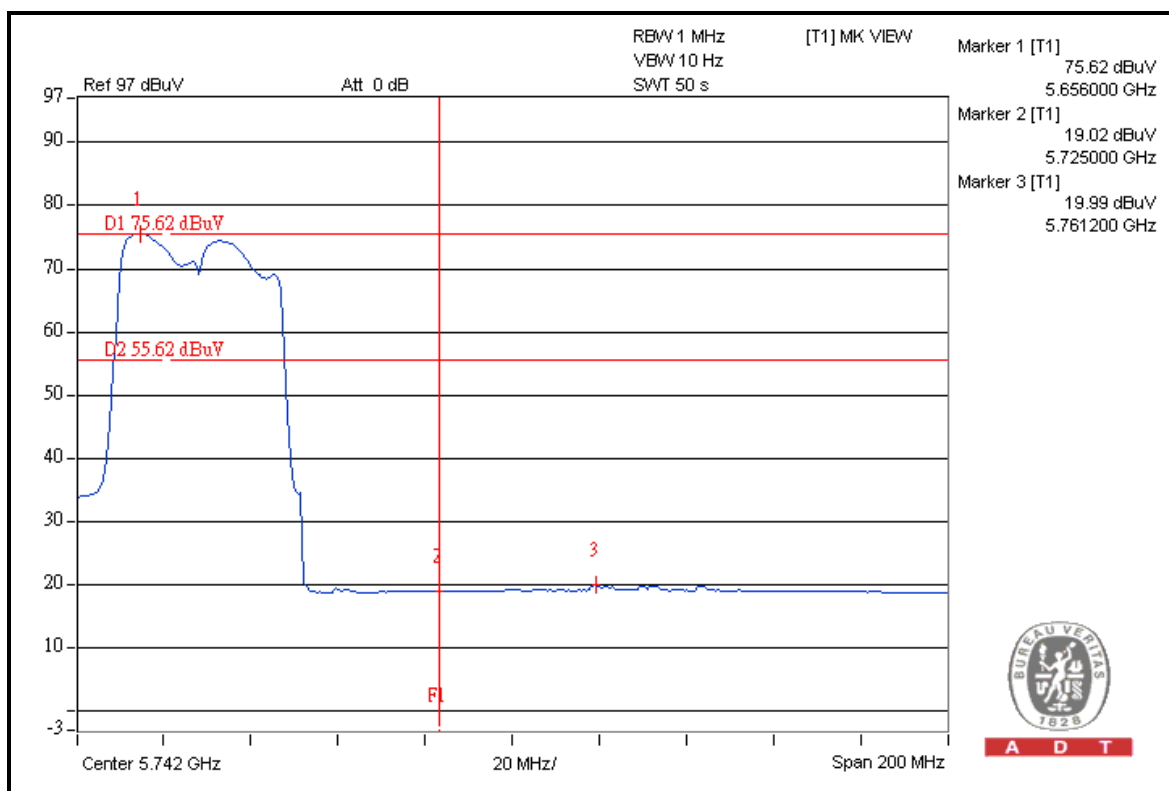

A D T

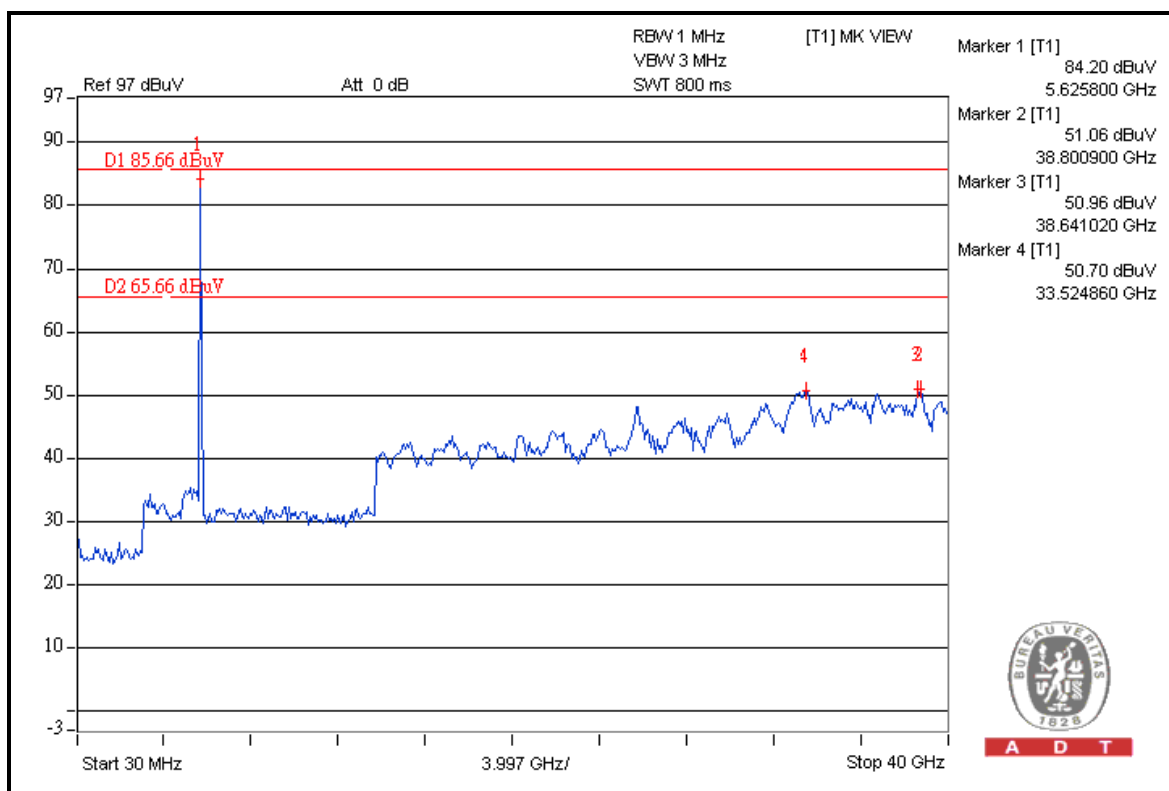

A D T

## 5. PHOTOGRAPHS OF THE TEST CONFIGURATION

Please refer to the attached file (Test Setup Photo).



## 6. INFORMATION ON THE TESTING LABORATORIES

We, Bureau Veritas Consumer Products Services (H.K.) Ltd., Taoyuan Branch, were founded in 1988 to provide our best service in EMC, Radio, Telecom and Safety consultation. Our laboratories are accredited and approved by the following approval agencies according to ISO/IEC 17025.

<b>USA</b>	FCC, NVLAP
<b>Germany</b>	TUV Rheinland
<b>Japan</b>	VCCI
<b>Norway</b>	NEMKO
<b>Canada</b>	INDUSTRY CANADA , CSA
<b>R.O.C.</b>	TAF, BSMI, NCC
<b>Netherlands</b>	Telefication
<b>Singapore</b>	GOST-ASIA(MOU)
<b>Russia</b>	CERTIS(MOU)

Copies of accreditation certificates of our laboratories obtained from approval agencies can be downloaded from our web site: [www.adt.com.tw/index.5/phtml](http://www.adt.com.tw/index.5/phtml). If you have any comments, please feel free to contact us at the following:

**Linko EMC/RF Lab:**  
Tel: 886-2-26052180  
Fax: 886-2-26051924

**Hsin Chu EMC/RF Lab:**  
Tel: 886-3-5935343  
Fax: 886-3-5935342

**Hwa Ya EMC/RF/Safety Telecom Lab:**  
Tel: 886-3-3183232  
Fax: 886-3-3185050

**Web Site:** [www.adt.com.tw](http://www.adt.com.tw)

The address and road map of all our labs can be found in our web site also.

## **7. APPENDIX A - MODIFICATIONS RECORDERS FOR ENGINEERING CHANGES TO THE EUT BY THE LAB**

No any modifications are made to the EUT by the lab during the test.

---END---